

JULY, 1964

50 CENTS

PHOTOFACT REPORTER

Including **Electronic Servicing**



ELECTRONICS AT THE FAIR



SPECIAL ISSUE

PLUS COMMUNICATIONS SUPPLEMENT

IA 2L 1104 1266
WM. M. DAVIS
RAD. & TV SERV.
118 RIVERSIDE AVE.
CANNON CITY, COLO.

IN THE UPPER MIDWEST TOO, SERVICEMEN AGREE:

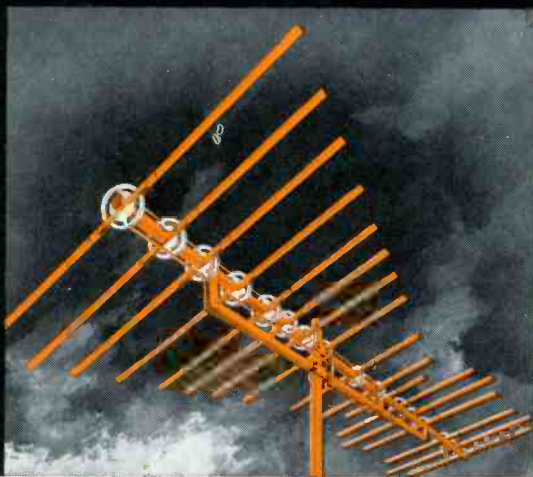

JERROLD PARALOG IS THE GREATEST!

Still the raves come in! TV service dealers all over the country keep switching wholeheartedly to Jerrold-Taco PARALOG antennas.

These dealers in Minnesota and North Dakota have gone 100% Paralog after putting it to the test under the roughest reception and weather conditions. And they've found that Paralog goes up easiest, stays

up without callbacks, and delivers by far the best pictures on all channels.

How about *you*? Have you tried the Jerrold-Taco Paralog side-by-side with its nearest competition? If not, see for yourself what's made the Paralog line the selling sensation in TV antennas.



**HARRY PFLAUM, HAUGNERS
TV & RADIO, DEVILS LAKE, N.D.**

"Every time we put up a Paralog antenna we create a satisfied customer. We are pleased with the construction and ease of installation of Paralog, and its terrific set performance."

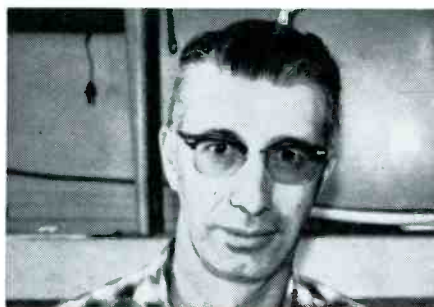

**LOUIS ALLERY,
ROY'S RADIO & TV, ROLLA, N.D.**

"In our part of North Dakota we need the best-constructed and best-performing antenna made. Paralog is all of this and then some. And installation is easy because of factory preassembly."

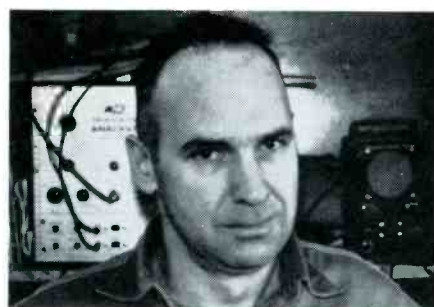

**ED JOCHIM, NESTORS
RADIO & TV, LANGDON, N.D.**

"Paralog withstands the terrific ice and wind problems we have here in Langdon, where other antennas have failed. We also like the ease and speed of installation."



**EUGENE DOLL,
DOLL'S TV, PERHAM, MINN.**

"Business has been terrific on Paralogs in our territory. And no wonder. Everybody who buys a Paralog is happy with the reception. We've gone to Paralog 100%."



**LAWRENCE DARGUS,
DARGUS RADIO & TV, WARREN, MINN.**

"Paralog antennas really perform well here in northern Minnesota—better than any other we've tried. And they're built rugged to withstand our rough winters."

For complete information, write

DISTRIBUTOR SALES DIVISION,
JERROLD ELECTRONICS,
PHILADELPHIA, PA. 19132



Circle 1 on literature card



A revealing look at modern electronics the world over

by Forest H. Belt

On April 22, 1964, in a large ex-swamp called Flushing Meadow near New York City, an exposition began that, for sheer complexity, almost overwhelms the imagination. The opening of the New York World's Fair, a gigantic international exchange of culture and technology, introduced an electronic era of trade and cooperation unknown in the annals of history. The Fair's deep commitment to electronics is affecting the lives and thinking of consumers, manufacturers, distributors, and those responsible for maintenance and servicing all over the world. Significant are the varied electronic devices being used in some of the most impressive exhibits on Flush-

ing Meadow. The Fair has a futuristic format, and everywhere the visitor turns he finds applications of electronic skills and techniques.

He sees, however, only a comparatively small part of the total electronics picture. Hidden from his eyes are thousands of electronically controlled devices doing jobs that until recently have been suggested only in science fiction.

On display and behind the scenes, this 1964-65 World's Fair has an impressive collection of many electronic miracles of this exciting age. To examine every electronic application at the Fair would require compilation of a large book, but the ingenuity revealed in that book would be a tribute to the cumulative efforts of some of today's most talented electronics engineers. Furthermore, keeping these hundreds of electronic "gadgets" in operation 12 hours a day, 7 days a week, demands the abilities of some of the best troubleshooting experts in the world.

Your PF REPORTER editors recently visited the Fair to bring you a first-hand report. We saw electronics on display, electronics being used to activate and control other displays, and electronics at work in the complex administration of this 646-acre tract where thousands of people move in every direction, from pavilion to pavilion, in a continuous throng. We were awed by the apparently limitless ways in which the use of electronics is making the 1964-65 New York World's Fair more impressive. Come along with us now, and we'll

take you on a word-and-picture tour of the Big Fair, pointing out those features of particular interest to the electronics-minded visitor.

Color TV Center

Gate 1, the main entrance for most Fairgoers, opens directly in front of the RCA Color TV Communications Center, as you can see from Fig. 1. RCA plays a many-faceted part, providing dozens of services for the overall operation of the Fair and widespread facilities for broadcasts originating within the giant Fairground. The ultramodern RCA building is laid out in the shape of three large cylinders on a 30,000-square-foot plot.

In the part of the exhibit that comprises the first cylinder, the visitor can stand in front of a live color television camera and see himself in both front and side views. For the 600 persons-per-hour who visit the RCA exhibit, however, the principal attraction is a guided tour of an operating TV-broadcasting studio and control room, contained in the other two cylindrical sections of the building. The studio and control room are surrounded by a glassed-in elevated walkway that completely encircles the extensive facilities. Through the glass, visitors can see action in both the studio and control room. They can watch every move of the directors, producers, and control operators, observe cameramen dollying in and out, and view, on several monitors, the results of those activities. They can also see how shows are taped, played back, retaped, and edited. All programs can be viewed on monitors located throughout the building.

Programming in the circular studio includes interviews with famous personalities visiting the Fair, style and fashion shows, cooking demonstrations by world-famous chefs, and special performances. Some programs are developed expressly for the entertainment of Fair visitors; some are also rebroadcast over WNYC-TV, New York.

To serve the Fair itself, the studio and control-room facilities will soon become part of the world's largest CCTV system consisting of 300 color receivers situated throughout the Fairground. Features of this system will include an-



Fig. 1. Main gate entrance to World's Fair.



Fig. 2. Demonstration of education methods.

PF REPORTER, for July, 1964, Vol. 14, No. 7. PF REPORTER is published monthly by Howard W. Sams & Co., Inc., 4300 W. 62nd St., Indianapolis 6, Indiana. Second-class postage paid at Indianapolis, Indiana. 1, 2 & 3 year subscription prices: U.S.A., its possessions, and Canada: \$5.00, \$8.00, \$10.00. Other countries: \$6.00, \$10.00, \$13.00. Current single issues 50¢ each; back issues 65¢ each.

July, 1964/PF REPORTER 1

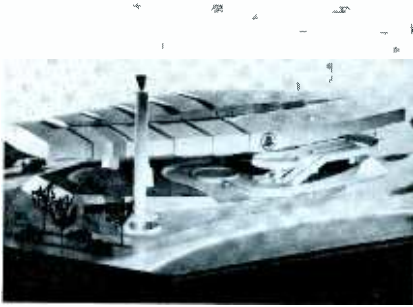

Fig. 3. "Floating wing" of the Bell System.

nouncement of VIP arrivals, short segments concerning history of the Fair, details of important exhibits, spot news developments from various points on the premises (picked up remotely by a complete mobile color-TV studio), aid in locating lost articles, suggestions on how to travel around the Fairground, where to dine, and many other helpful high-lights.

The RCA color CCTV facilities are also used, in cooperation with the Pinkerton police who patrol the Fair, to restore missing children to teachers or parents. Lost children are brought by uniformed Pinkerton men to the color studio where their picture is broadcast over the Fairgrounds system with instructions for reclaiming them.

An impressive array of television station equipment fills the racks and panels of the control room. Three video tape recorders stand ready to record any of the program material for rebroadcast at any time, and elaborate video- and audio-control consoles permit broadcasting or recording any form of AM, FM, or TV show. In the circular studio, illumination is provided by the very latest Kleigl lighting equipment. Thus, color-sensitive electronic eyes serve the Fair from the most modern color-TV center ever built.

Computers on Parade

Our next stop is the *National Cash Register* pavilion located in the Industrial area of the Fair where it faces the Court of the Moon. As you may suppose, electronic computer systems play an important part in this exhibit, with the Model 395 all-transistor system receiving the spotlight. To demonstrate their feature computer, NCR hosts ask visitors to choose any number, which the computer immediately expands into a 25-place square of 5 columns and 5 rows. Figures in both the columns and the rows can be totaled in any direction to equal the number initially chosen. A diagonally totaled number also equals the starting figure.

An NCR information-retrieval exhibit supplies automatically teletyped answers to questions selected by visitors from a prepared chart. When a button that corresponds to the question is pressed by the visitor, the readout typewriter types out the answer.

National Cash Register has also done other research, some of special interest to the television industry. For example, the NCR display demonstrates—through a magnifier—a TV picture displayed on a 1/16" television screen. This is, of

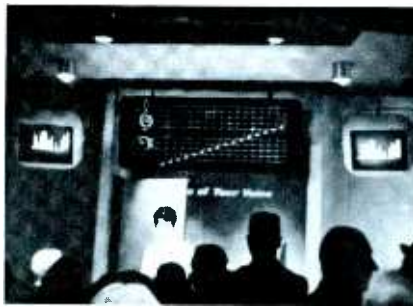

Fig. 4. Voice patterns are on video monitors.

course, a bit too small for even the tiniest portable imaginable, but the precision required, in the phosphor coating and in the sweep system, to achieve a clear image on so tiny a surface is impressive. No doubt this CRT will open up important advances in high-resolution TV receivers.

Walking toward the Pool of Industry, we arrive at the pavilion of *International Business Machines* and join a group waiting to assemble on the "People Wall" beneath the 90-foot-high "egg" theater.

The IBM exhibit was designed to give the average Fairgoer an insight into complex computer operations. Short plays, puppet shows, and films shown in the pavilion are used to dramatize the story of computer development. The 45° "Wall" lifts us into the theater where we are shown nine films devoted to man's thought process and how he has developed computers to do certain portions of his thinking. The concepts established in the films are then reinforced by several mechanized puppet shows, staged on the floor below, that dramatically demonstrate the logic of computers in a most entertaining manner.

Electronics for Learning

As we walk around the Promenade of Industry, our next stop is the Hall of Education. Housed in a 50,000-square-foot building facing the Pool of Industry, this enormous exhibition hall contains dozens of booths and display cabinets showing present trends in education and presenting futuristic concepts of what



Fig. 5. Anechoic chamber in the Bell exhibit.

schools, classrooms, and teachers will be like a few years hence. Interest in the Hall seems to center around the recently completed Communications Demonstration Center (Fig. 2), symbolized by the catchword "Educom." Coordinating the installation and operation of the complex electronic system in this exhibit is *Visual Electronics Corp.*, New York manufacturer and distributor of broadcast and communications systems and equipment.

Many of the audio and visual teaching techniques we see demonstrated here are already being used in classrooms around the country, while others soon will be. A few are in the experimental or advanced-planning stages, but all are technologically feasible; their usefulness and practicality are being tested in actual classroom and home-teaching situations.

Obviously, an undertaking of this size requires the efforts and products of many companies. The Communication Center's electronic equipment utilizes audio devices built by *KRS Electronics*, *McCurdy Radio Industries*, *Comrex*, *Electro-Voice*, and *Harmon-Kardon*. Video equipment includes that of *Visual Electronics Corp.*, *Conrac Div. of Giannini Controls*, *GPL Div. of General Precision Instruments*, *TeleMation, Inc.*, and *Jerrold Electronics*. Film and slide equipment comes from *Fairchild Camera & Instrument*, *Graflex*, *Bell & Howell*, *Bodde Screen and Projector Co.*, *Radiant Mfg. Co.*, and *Spindler & Sauppe*; studio equipment from *Machtronics*, *Century Lighting*, *E. J. Baughman Co.*, and *Emcor*; and test equipment from *Harmon-Kardon* and *Tektronix*. This impressive list of manufacturers illustrates how important electronics will be in the classroom of the future. Electronic teaching aids include a special programmed - learning student - response system produced by *Edex Corp.*, a dial-controlled learning system from *Chester Electronics*, and a "Language Master" teaching machine from *Bell & Howell*. *WNYC-TV* has provided facilities for the radio and television studio. In all, the Center is a real tribute to the cooperation of participating manufacturers.

In addition to classroom demonstrations, visitors to the Center will see how education and instruction can be extended into the home or into multiple classrooms via special pushbutton automation. Employing a device called the "Studysphere," an individual student can receive highly personalized instruction at home. Furthermore, a single student (or several) can receive personalized instruction through television—closed-circuit or aired. With ETV stations springing up all over the country, such programs not only are possible, they are actually in use. Some are received and studied at home, and some at school; many can be studied both places.

A Study in Communications

Another pavilion of interest for its electronics is that of the *Bell System*. Dominated by a 140' microwave tower, the "floating wing" structure (Fig. 3) sits on a 2½-acre plot facing the Pool of Industry. At the base of the tower, a glass enclosure permits passersby to inspect racks that contain microwave

relay equipment used to transmit Fair-originated TV programs into New York City. The Bell microwave tower and control-room facilities serve both the RCA and Hall of Education exhibits when live shows are relayed to New York for taping or rebroadcasting.

A "ride" in the Bell exhibit takes the visitor past some 50 scenes from the history of communications. A separate taped-sound system in each of the 1000 continuously moving chairs is piped to the passenger via adjustable earphones built into the chair. Each playback machine is synchronized to provide the visitor with a commentary on each scene as he passes by.

Of far greater interest to the electronics-minded Fairgoer is the exhibition hall in the lower level of the Bell building. Bell has developed some unusual ways to demonstrate various phenomena associated with electronics—devices such as the "visible speech" demonstration (Fig. 4), a combination of graphic displays that show various effects that can be produced by the voice of the demonstrator. We enter this lower hall through an acoustical lock (Fig. 5) that demonstrates how an anechoic chamber deadens sound by eliminating all reverberation.

A real crowd-stopper in the hall is a group of booths where the visitor can actually use one of the experimental "Picturephone" systems—Fig. 6. The unit shown also contains "Touch-Tone" dialing (a feature incorporated in all telephones at the Fairground) and the hands-free "Speakerphone."

The "Picturephone" contains only two tubes—a 1" vidicon camera tube and the 6" CRT picture screen. Transistors handle all the rest of the work inside this miniature CCTV system. The vidicon has an f/1.9 lens with a focus range of 29" to 48", covering a field 12" x 16". The receiver section displays a reasonably defined picture, scanned "on end" at 275 lines per frame, 30 frames per second. The system requires a three-pair cable with a bandwidth capability of about .5 mc—not bad considering the definition; one pair is used for audio transmission and two pairs for video.

Other Bell exhibits include: demonstrations depicting lasers and masers, solar batteries, satellites, computers, transistor development and manufacturing, logic and memory games in which the visitor can participate, testing and quality-control devices for telephone manufacturing, a special wave-behavior exhibit, and undersea cables that use time-diversity techniques for increasing the number of simultaneous messages that can be handled by one cable. A colorfully lighted display reveals the complexities of telephone networks to the nontechnical visitor.

Electrical Progress

Another short walk around the crescent-shaped Promenade of Industry, which partially encircles the Pool of Industry, brings the visitor to another giant electronics exhibit, that of the *General Electric Co.* Their building alone is noteworthy—a self-supporting 80' dome (Fig. 7) that uses, for the first



Fig. 6. "Picturephone" communication system.

time, special "curvilinear lamella" construction techniques. At night, colored lights on the dome blink on and off in a tape-programmed sequence that gives an observer the impression that the entire dome is revolving.

Inside, the visitor is treated first to a ride in G-E's "Carousel of Progress." The "Carousel" is a huge circular auditorium, divided into six 250-seat sections, that revolves around five stages. The first stage, the loading area, contains a gaily lighted screen that changes color in time with music. Once everyone is seated, a process that takes approximately four minutes, the huge merry-go-round whisks around to the second stage to the tune of the "Progressland" theme song—"There's a Great, Big, Beautiful Tomorrow!" A four-minute show portrays living conditions during the 1880's, prior to the development of regular uses for electricity. The play is acted out by amazingly lifelike figures, created by Walt Disney and called "audio-animatronic" people. The figures are deceptively realistic—their eyes blink, lips move as they talk, fingers twitch occasionally, heads turn, feet tap out musical time; "mother" irons, and the dog even raises his head and growls.

To the accompaniment of the theme tune, sung by Rex Allen, whose voice is also heard as "father's," we are transported around the remaining third, fourth, and fifth stages, stopping four minutes at each to view the electrical side of life in the 1920's, 1940's, and finally the mid-1960's. At the sixth stop, we all disembark and are carried up a moving "time tube," to walk along a hall where kaleidoscopic mirror effects (also arranged by Disney) show over 100 photo-scenes relating to research being carried on by G-E scientists.

The mirrored hall leads to a darkened area where we lean back to watch the "Skydome Spectacular," a show projected on the domed ceiling of the build-

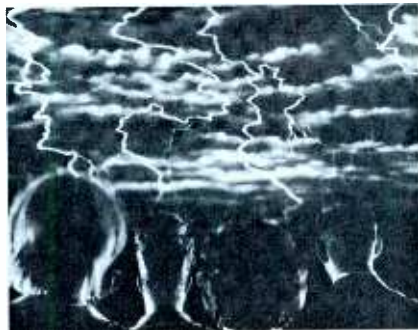

Fig. 8. Realistic storm projected on dome.



Fig. 7. Lighted dome seems to spin at night.

ing. The effects created are spectacular: lightning flashes, thunder rumbles and then crackles startlingly; the crowd actually shivers as a storm that seems to stretch as far as the eye can see is unleashed on the screen (Fig. 8). The storm is replaced by the searing flames of the sun, and the flames give way to spinning atoms that move across the "sky"; the narrator explains the tremendous power unleashed by nature and suggests that man has learned to do the same.

Then, to see proof of the point, we are lead down a ramp to witness an actual demonstration of the controlled fusion of deuterium atoms. To produce the reaction, a bank of capacitors is charged to 60 kv, and deuterium gas in special quartz enclosures is preheated to a dull glow. Following a dramatic countdown, the capacitors are discharged through two coils positioned around the quartz tubes. The pulse sends about one million amps through the coils for part of a microsecond. We involuntarily jump at the sudden sharp report and the blinding flash as the deuterium atoms fuse at temperatures as high as 100,000,000°F. The fusion reaction itself takes about six microseconds, too short to be dangerous but long enough to release significant and measurable neutron energy.

Downstairs, in a model all-electric community called "Medallion City," visitors can see: "Steinmetz High School," where CCTV and audiotape (language-lab-type) teaching machines tutor students in an electronically climate-controlled classroom; "City Hall," where two-way radio, CCTV, automated traffic control, and automated highspeed transit systems make city life safer; "Coolidge Hospital," where medical electronics, X-ray, and two-way and CCTV communications networks are saving lives; and modern homes where electronics is contributing to greater leisure.



Fig. 9. Video switching panel for GE CCTV.



Fig. 10. Fountain of Planets erupts to music.

While the "show" at G-E is meaningful, the real electronics spectacular is behind the scenes, where some of the most advanced techniques are at work. The heart of the giant "Progressland" display is a GE-225 computer that programs the proper sequence of up to 1400 separate actions. Four tape machines, built by *Precision Instruments Corp.*, handle automation for the audio-animatronic figures and for the "Skydome Spectacular." Using 1" magnetic tape, preprogrammed with 32 tracks per tape, two of these machines alternate in operating the entire "Carousel" system. When the first machine finishes the sequence contained on one tape, an automatic switchover sensor places the other machine in operation while the first rewinds.

Some of the 32 magnetic tracks contain the recorded voices of the audio-animatronic figures and other sound effects, including the theme song and the growling dog. Other tracks contain audio-frequency impulses used to actuate pneumatic and hydraulic valves in the figures; flexible tubes and other mechanical devices expand and contract as fluid and air are sent into and out of them, causing lifelike movements and changes of facial expression. Similar recorded tape pulses control lighting, movement of the carousel theaters, and scenery changes on the



Fig. 11. As music changes, so do fountains.

stages, thus providing control of the entire six-step "show" from one tape. The other two 32-track tape machines alternate with one another to control the projectors and provide sound effects for the "Skydome Spectacular."

All this would seem like enough electronics for one exhibitor, but there is more. A 20-camera closed-circuit TV system keeps an electronic eye on various entrance ramps and areas in the "Progressland" pavilion. Video switching panels and monitors in key spots (Fig. 9 shows one monitoring console) enable G-E personnel to keep track of what's going on. In the event of trouble with the huge carousel theater, the system would facilitate orderly control and evacuation of the crowds.

At various exits and entrances to the giant dome, Pinkerton security guards are equipped with tiny hand-held walkie-talkies. Just another use for electronics at the Fair. . . .

Musical Showers

Leaving the giant dome of G-E "Progressland," we discover that darkness has fallen. As we step out along the Promenade of Industry, huge fountains in the Pool of Industry suddenly erupt, sending colored sprays of water high into the air

—Fig. 10. Thus begins another breathtaking display of the "Fountain of the Planets," a musical ballet of colored fountains (Fig. 11) accented by periodic showers of fireworks.

This colorful performance of the largest fountain ever built is totally automated. The music, the changing spray patterns, the changing colors (including a true flame color achieved by using actual flames), the fireworks, are all controlled by tone pulses on one track of a two-track RCA audio tape machine. More than 500 separate effects are turned off and on several times during the 30-minute performance. The other tape track contains a half-hour medley of well-known tunes specially recorded for the display by a 60-piece orchestra.

A bank of RCA amplifiers drives one of the most unusual speakers ever built. Weighing 3½ tons, this giant 16' speaker radiates some 10,000 watts of audio power upward and outward to accompany the dancing fountain. The speaker is shaped like two huge metal saucers joined bottom-to-bottom by three circular tiers. Each tier contains 16 cast-aluminum horn sections with separate drivers. The 48 horns in this unusual design radiate sound in a powerful vertical "mushroom" that enables listeners to hear almost as well at 600 feet as at 300 feet.

Satellites

After a night's rest, we start another day by entering Gate No. 3, the Peter Stuyvesant Gate. The first display we encounter contains several types of earth satellites (Fig. 12): communications satellites Echo II, Telstar, Syncom, Relay, and the weather satellite Tiros. Of particular interest are the solar cells used to power these electronic denizens of outer space.

Behind the Scenes

A short walk up the Avenue of Science brings us to the *Ford Motor Co.* exhibit. In the lobby, visitors file past Ford's ten "International Gardens" displays, tiny replicas of communities in different countries. In each, the theme song of the Ford display can be heard—in perfect harmony with all other "countries," except that the music is being played with instruments in the style of that particular country. As in many exhibits at the Fair, the electronic devices in this pavilion are mainly behind the scenes; instead of being on display, they control the special effects to dramatize other facets of the past, present, and future world.

Upstairs in Ford's electronics control room, we find two *Precision Instrument Co.* recorders (left side of Fig. 13), similar to those being used in the Disney audio-animatronic display at G-E. The units here are of 14-track configuration, threaded with "Scotch"-brand 1" magnetic tapes, and are used to provide synchronized sound for the "International Gardens." Two units are used alternately for continuous operation; a blank spot at the end of each tape automatically triggers the changeover

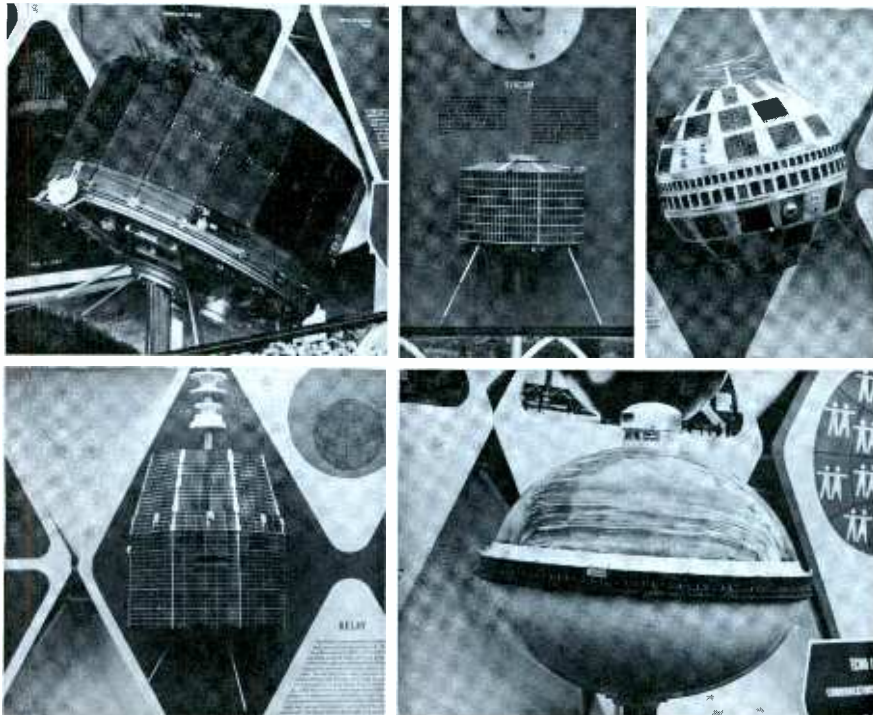

Fig. 12. Communications and weather satellites form a very modern electronics display.



Fig. 13. Amplifiers and 14-track tape units.

switch on the standby tape machine and allows the first to rewind. Banks of 70-watt RCA amplifiers (Fig. 13) provide sound power for all the systems in the building, including the audio-animatronic figures in scenes along the Ford "ride."

The visitor rides through this display in a driverless brand-new Ford-built convertible, which is pulled along a guide track. Narration for each segment of the exhibit is prerecorded on continuous-loop cartridge tapes; a playback machine is mounted in the trunk of each auto (Fig. 14). These playback units are "Wayfarer" machines, built by *Taiko*, and are similar in appearance to Viking units. They have been specially converted to four-track playback by Paul Colosimo of *City Animation Co.*, Detroit. Tapes are wound in *Fidelipak* cartridges, with the narrative on each of the four tape tracks recorded in a different language—English, French, German, and Spanish—to accommodate the international audiences. Passengers in each convertible, by depressing the appropriate pushbutton on the car "radio," can choose whichever track (language) they understand best. As the visitor rides past a scene, the tape machine runs to the end of the narration about that scene and stops. When the next scene is approached, a microswitch beneath the car passes over a trigger, actuates the machine, and the next recorded sequence begins.

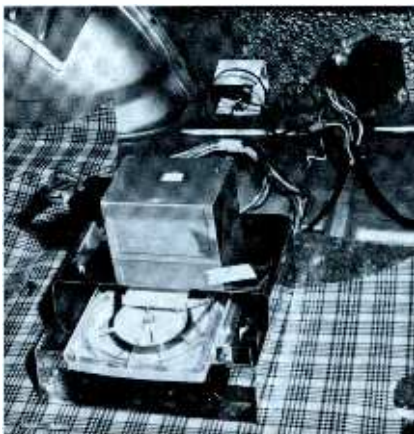

Fig. 14. Narration is from cartridge tape.

The diaramas contain audio-animatronic figures that are not quite so lively as those at the G-E pavilion, but are certainly realistic. Their sounds, and those of various prehistoric animals that accompany them, are recorded on four-track cartridge tapes. They are played back on *KRS "Stact"* tape machines (upper right, Fig. 13), amplified in RCA amplifiers, and fed to speakers in the various scenes via 70-volt distribution lines.

Below the Surface

In the next exhibit we visit, electronics plays secondary but admittedly important roles. The *Underground Home*, built and operated by *Underground World Home Corp.*, is exactly what its name implies—a complete dwelling beneath the ground. In almost every room we see *G-E* television receivers, including a color set in the living-room entertainment center. TV signals are picked up by a *Channel Master* antenna mounted above ground, amplified by *Channel Master* and *Winegard* amplifiers, and distributed among the six rooms by *Viking RF* tapoffs. The living-room entertainment center also contains complete stereo tape, stereo phono, and AM-FM-Stereo receiving equipment built into the wall and covered by folding doors. An electronic organ built by *Thomas Organ Co.* is but one more piece of electronic equipment the service technician will find in this home of the future. Connecting various rooms of the house is an intercom system, with the master unit mounted beside the kitchen TV set.

A most unusual lighting system offers some very realistic lighting arrangements; silicon-controlled rectifiers are used in the controls. From the master panel, "outside" patio lighting can be made to simulate bright daylight, comfortable twilight, or nighttime—with or without stars and moon. An interesting lighting effect is used in the kitchen ceiling—a "skylight" (Fig. 15) that is actually 15 feet below the earth's surface; an SCR control adjusts the amount of "daylight."

Electronic controls maintain an even climate in this all-electric home the year around. The insulating qualities of the surrounding earth help keep heating and cooling bills well within reason. This home of tomorrow provides further evidence that the technician of the future is going to find plenty of new equipment to maintain and service; he'd better keep up-to-date with advancements like these.

Leave the Driving . . .

Moving on around the Avenue of Transportation, we next encounter the *Socony-Mobil* pavilion where visitors can test their driving skill in a simulated "Economy Run." Thirty-six test units, complete with bucket seats, steering wheels, accelerators, brakes, and speedometers, allow drivers to test their reaction to several driving hazards during a four-minute test run. Most visitors, however, fail to realize the amount of electronics equipment that makes the test possible. A few statistics: the system contains over 4200 light bulbs, 2500



Fig. 15. "Skylight" is SCR-controlled lights.

transistors, 100,000 feet of wire, and over 600 rheostats, relays, and micro-switches. The units were designed and built by *Dramaturgy, Inc.* of Cleveland, and *Dage Television Co.* of Michigan City, Ind.

Drivers view the road by means of *Dage* CCTV monitors placed at windshield level. On the screen, various filmed traffic situations are shown. Drivers react to such things as train gates, approaching cars weaving in and out of traffic, careless pedestrians, and stopped school buses. Potentiometers connected to the steering wheel, brake, and accelerator keep track of motions made by the test driver. These motions are factored in a computer to find an average score, which is shown to the driver as "miles per gallon."

In the control center, two *Dage* television camera film chains run in exact synchronism, one for the test and another for "crash scenes." If a driver in any situation exceeds certain limits of safety, a relay trips and his monitor is switched to a crash scene for that particular situation. Both films have optical sound tracks to provide realistic road noises, crash noises, etc. An additional magnetic track contains perfect-driver reference information that is compared, in the computer, with the actions and reactions of the test "driver." These "perfect" reactions were prerecorded by an expert test driver under actual driving conditions over the course from which the filmed scenes were taken.

Future Living

Since we couldn't brag about our scores to "drivers" waiting to take the test, we crossed the Avenue of the United Nations to the *General Motors* pavilion (Fig. 16)—a huge structure that in profile looks like a jet airliner.

The theme of GM's exhibition is "Futurama," and the visitor transport system



Fig. 16. "Futurama" pavilion lit up at night.



Fig. 17. Color set is converged with mirrors.

takes the Fairgoer through a series of imaginative but plausible "cities of the future." Men at work on the moon, a community in Antarctica, a gigantic roadbuilder in the jungle, ultramodern cities within cities under a single roof, a continent-wide system of ultraspeed highways, a complete series of settlements on the bottom of the ocean—are all shown in amazing detail. The "tour of the future" utilizes an endless loop of seats, three abreast, continuously moving past three-dimensional scenes. The narration is recorded on tape, and the playback machines each serve about nine seats. As with displays visited earlier, the tape playback is synchronized with the movement of the seats past each scene. The sound comes from speakers built into the "wrap-around" chairs, approximately at ear-level.

From the Orient

A long walk up the Avenue of the United Nations brings us to the Japan pavilion next to Eisenhower Promenade, near the Fountains of the Fairs. On the second floor of this building is the largest single visible display of electronics equipment at the Fair. Participating in this exposition that showcases nearly every facet of the Japanese electronic industry, we spot the following companies immediately: *Sony Corp.*, *Sanyo Electric, Inc.*, *Nippon Electric Co.*, *Hitachi*, *Tokyo Shibaura Electric Co., Ltd.*, *Nivico (Victor Co. of Japan)*, *Matsushita Electric Corp. of America*, *Mitsubishi Electric Corp.*, and *Japan Electron Optics Laboratory Co., Ltd.*

Attracting considerable attention in



Fig. 18. Sixteen-inch rectangular color set.

the *Mitsubishi* booth was a small-screen color TV receiver (Fig. 17). Most small-screen color sets aren't too unusual, but the approach to color used in this set is. Three CRT's with filters are used, one for each of the three basic colors—green, blue, and red. Dichroic mirrors superimpose the three images in the same plane, and the viewer sees only a single image converged on the viewing reflector. The interior is not displayed so we can't see just how convergence is accomplished, but it would seem slightly complicated; vertical and horizontal size and linearity must be precisely the same on all three CRT's, and mechanical positioning of the mirrors would seem quite critical. The converged image is recessed in the unit, as you can see from the photo of Fig. 17, thus narrowing the viewing angle from which the image can be seen.

Behind us, as we watch the small color set, other visitors are watching a wall of tinyvision receivers—a bank of 6" portables of the type being marketed in the U.S. by *Singer Corp.* Most of the sets we see in this display are equipped for UHF reception in accordance with the recent All-Channel Law. Apparently the Japanese have been preparing for the April deadline the same as have U.S. manufacturers. The UHF tuner is attached to the bottom of the set.

Mitsubishi has other electronic products on display: transistor AM, FM, AM-FM, shortwave, longwave, and multiband receivers—both portable and home-type—and several models of CB receivers and transceivers.

Moving again, we spot several other color receivers (Figs. 18, 19) of the 16" rectangular variety being introduced to the U.S. market by Japanese manufacturers. Some of them could not be inspected internally, but they all seem to be similar except for cabinet design. We stop for an inside look (Fig. 20) at the one made by *Victor Co. of Japan (JVC or Nivico)*. Several points are noteworthy: The controls are arranged similarly to those in American sets; even the convergence panel looks familiar (upper left in Fig. 20). There are three screen and two drive controls for the three-gun CRT, and a service switch for setting up. Three convergence magnets and coils are arranged around the CRT neck, and we notice the blue gun is at the bottom instead of on top as in the U.S.-made sets.

Some Japanese manufacturers tell us these sets are not ready for market yet, but certain U.S. importers have announced their intentions of selling them by late this summer. We see no evidence of a set using the two-gun Chromatron picture tube; apparently it isn't at the Fair yet.

Another interesting device at the *Nivico* booth is the video tape recorder shown in Fig. 21. Very little information about the unit is available, but its size is relatively small compared to the units we saw in the Communications Center. We can't see it in operation, so it is difficult to appraise its capabilities.

Further along the aisle, *Hitachi* displays (Fig. 22) a wide variety of elec-

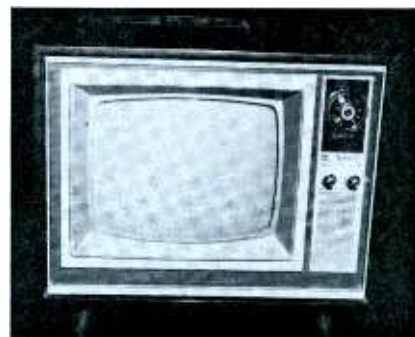

Fig. 19. Except for size, appears like ours.

tronic parts, especially transistors and tubes. In addition to semiconductors for almost every application, we see several nuvistors built by them, and klystrons and vidicons for industrial electronics. Some vidicons are of broadcast quality.

The *Toshiba (Tokyo Shibaura)* booth includes another of the 16" color receivers, some black-and-white sets (suspended on pipes from the ceiling), and several transistor stereo radio and phono sets. Along the walls, a display of parts built by Toshiba features a storage tube whose phosphor can hold a still picture for several hours and then feed it into a TV set for as long as 30 minutes. The unit resembles an image orthicon tube. A small transistorized television camera, auto radios, tape recorders, and some small electrical appliances round out the Toshiba exhibit.

In addition to the color receiver shown in Fig. 18, *Matsushita Electric* is displaying several models of tape recorders, stereo hi-fi units, radios, and black-and-white TV sets, including their "Mitey-9" transistor portable TV. Under the brand-name "Panasonic," electronic products by Matsushita are being distributed all over the U.S., particularly in the Midwest.

Across the aisle, *Sanyo Electric, Inc.* is displaying a variety of home-entertainment products that encompasses electronic organs, advanced-design portable radio-phonos, auto radios, stereo sets, kitchen appliances, and transistor radios. Also prominent in the booth is a placard by *Channel Master* of Ellenville, N. Y., displaying a couple of the transistor portable radios built by Sanyo and distributed by Channel Master in this country.

Undoubtedly the largest electronics booth in the Japanese pavilion is that of *Nippon Electric Co.*, a giant electronics company of Japan. A small part of the booth can be seen in Fig. 23.

In addition to the usual transistor-radio products (which are strangely incon-



Fig. 20. Inside of 16" Japanese color TV set.



Fig. 21. Video tape recorder with controls.

spicuous in the exhibit), NEC builds electronics equipment of a most exotic nature. In the background at the right of Fig. 23 can be seen a large computer; telephone equipment is displayed along the front table. A tiny TV camera (Fig. 24) permits the passerby to see himself on a closed-circuit monitor at the rear wall. Also on display (Fig. 25) are several unusual medical-electronic devices, among which are: a heart-rate telemeter that can be strapped directly on an athlete while a receiver reports his exact heartbeat to the trainer or physician; an echo-type encephalograph, a device for measuring brain condition; special telemetry capsules that can be swallowed by a patient, after which a data receiver records temperature, acidity, and other body functions transmitted by the capsules.

Literature available at the NEC exhibit tells of microwave, broadcast, coaxial cable, power-line carrier, shortwave, medium wave, and longwave equipment NEC has in operation all over the world. The company is also taking an active part in research relative to space communications, computer technology, and other modern electronic developments.

Sony Corp. features its new "Video-corder," a lightweight video tape recorder that they hope will open up the field of home video recording. It is designed to be used with its own camera to record video information directly, much as the home recordist tapes audio sequences with a microphone; or it can be used to record video programs received from other sources. At a speed of 5 3/4 ips, a 7" reel of 2" video tape will hold one hour of television picture and sound. Two recording heads are used to record on the 2" magnetic tape.

Another item of interest is a 30,000-power electron microscope. This advanced research device, being displayed by *Japan Electron Optics Laboratory Co.*,



Fig. 22. Semiconductors, tubes from Japan.

Ltd., combines the arts of optics, electronics, and photography to accomplish an almost fantastic degree of magnification. The microscope is contained in a cabinet that takes little more space than an ordinary office desk and weighs only 390 lb.

Electronics Everywhere

Even the most casual visitor to the New York World's Fair will find electronics at work all over the Fairground. In addition to the many huge exhibits we've already described, you will find electronics in the most unexpected places. For example:

Ten tower-mounted clocks located over the Meadow will keep Fairgoers informed of the time and serve as easily found meeting places. These aren't ordinary clocks, however; they are slaves to a highly accurate crystal-controlled master clock similar to those used in broadcast stations all over the country. These at the Fair are part of a *Favag* system, installed by *Visual Electronics Corp.* From the master clock in the Timing Center at the Swiss pavilion, timing pulses are sent to the ten slave clocks, keeping them accurate within microseconds.

In the Billy Graham pavilion, Fairgoers can hear evangelist Graham's message in any one of six languages. Pushbuttons in the armrests of the seats select the desired language—truly an international place of worship.

In the Illinois pavilion, another of Disney's audio-animatronic creations, a lifelike figure of Abraham Lincoln, delivers a moving speech on Liberty. Stereo music, tape-controlled lighting, and the tape-controlled figure are all electronically activated—as is the closing and opening of the theater doors.

In the U.S. pavilion, a point of interest is the Audiovisual Learning Center (Fig. 26). In a "Study Station" booth (pictured at left), a student can be seated facing a control panel and TV screen. Programmed study courses are projected on the screen and through speakers in the booth. The student responds via the control panel, and computers test his answers and accept or reject them and offer remedial supplementary instruction, if required. In short, the "Study Station" system can do almost everything a teacher can do.

TV technicians will probably recognize the *B & K Model 1076 TV Analyst* in the equipment rack at the right, which is used to transmit the video from slides for the Study Station. Video tape recorders by *Ampex Corp.*, video monitors by *Miratel Electronics, Inc.*, video distribution panels by *Anzac Electronics, Inc.*, scopes from *Tektronix, Inc.*, video and audio tapes from *Minnesota Mining & Mfg. Co. (3M)*, and various other equipment from *Maryland Telecommunications, Inc.*, *North Atlantic Industries, Inc.*, *Pendar, Inc.*, and *Temple Sound Equipment*—are all incorporated in this working exhibit of the most advanced audiovisual teaching methods. Electronics all the way!

A modern library in the same pavilion



Fig. 23. A portion of the NEC exhibit booth.

uses computer techniques, similar to those we saw at the NCR pavilion, to show how easily information can be found. Books, trained librarians, and a *Univac* information-retrieval system offer a ready reference service to World's Fair visitors. Some 2000 standard reference books have been used to compile information in the computer storage system. If a system like this were programmed centrally with all knowledge that presently exists on any particular subject, "branch" readout systems located at colleges and libraries all over the country could have research information available almost instantaneously. Something to think about . . .

Everybody's In the Act

As the host country, we might seem to dominate the Fair. Such is not the case. Dozens of countries and companies are participating, and many are showing electronic products.

In the Austrian pavilion, visitors can view Austrian electronic products mounted inside plastic bubbles. One company that is well known to American broadcasters—*AKG of Vienna*—has a display of their most popular microphones.

Sweden has a spectacular demonstration in their pavilion, showing effects that must be overcome in ultra-high-voltage power transmission, a system they have developed considerably. They also have on display telephone and communications equipment built by *Ericsson*, one of Sweden's largest electronics companies.

Mexico has one tier on their second floor devoted to an exhibit of electronic products from Mexico. In a nearby pavilion, India displays electronic meters



Fig. 24. Small camera amuses NEC visitors.



Fig. 25. Several medical electronics units.

and cables manufactured in their country. These exhibits are informative to the Fairgoer who isn't accustomed to thinking of these countries as having significant electronics industries. Faraway places of the world are getting closer to home all the time!

The *Singer Co.*, although famous for its sewing machines, has only recently emerged as an electronics manufacturer and distributor. In their huge pavilion at the Fair, we see home entertainment products made by their recently purchased *KHL Electronics Div.* and some more of the small-screen transistor TV sets imported from Japan and marketed here by Singer. Several *Sylvania Model 800 CCTV* systems are also in evidence to allow visitors at the pavilion to witness sewing demonstrations. Other *Sylvania* cameras are placed so visitors can see themselves on TV—Singer TV, naturally.

The *Travelers Insurance* pavilion uses stage projection equipment and relay-controlled lighting—all controlled by magnetic tape—to present their "Triumph of Man" show, a 2½-million-year history of Man's progress. The magnetic-tape control system incorporates a four-track playback system; one track is used to key the projection and lighting equipment, while the other three carry sound for the show.

Pepsi-Cola Co. has what is probably one of the most intricate and colorful displays at the Fair. Designed by Disney, several hundred foot-high audio-animatronic doll-children (Fig. 27) represent virtually every country of the world. A

tribute to UNICEF, the exhibit's theme is "It's a Small, Small World." The hundreds of dolls, with changing expressions, flirting eyes, and in perfect harmony, sing the theme song in their respective languages. Passage through the exhibit, by boat, takes the visitor on a memorable simulated tour of the world to the lilting tune of "It's A Small World, After All," written especially for the exhibit. The electronic systems involved in the Pepsi-Cola display are very much the same as those described for other Disney exhibits, although an unusually large number of actions must be controlled; the science of audio-animatronics makes the tiny dolls behave almost like real children.

In the field of electronics, *Eastman Kodak* is displaying sound-track movie equipment for the home and professional photographer, and is showing a new line of sound tape for both the amateur hobbyist and the professional audio recordist.

A Last Look Around

Yes, electronics is really in evidence at the Fair. Everywhere we turn, we see some familiar electronics company taking an active part. Some are participating in a big way behind the scenes; others are playing a more direct and equally important part.

As we learn more of what's happening at the Fair—in full view and beneath the surface—these are some of the other electronics participants we encounter: *EICO Electronics Instrument Co., Inc.*, who (at the Pavilion of American Interiors) is demonstrating a special electronic color organ—the "Eicolortron"—that flashes multicolored lights in unison with music played on the instrument, and who has recorded for Fair visitors a cartridge-tape discussion of kit building; *JFD Electronics, Inc.*, whose TV and FM antennas have been chosen for use at the House of Good Taste, Formica House, Eastman Kodak pavilion, State of Florida pavilion, and Hawaiian pavilion; *Conrac Div.* of Giannini Controls, whose weatherproof TV monitors we discover in some of the most unexpected places; *RCA*, who has supplied 550 small speak-



Fig. 27. Doll-children of world hail UNICEF.

ers for the World's Fair public-address system and has color TV sets spotted all over Flushing Meadow; *Crown International*, who has furnished stereo playback machines for several exhibits at the Fair, including some thirty-odd for the Bell Telephone display; *Altec Lansing Corp.*, who has developed sound systems for more than 15 separate pavilions and exhibits, and who has its own exhibit of stereo playback equipment in the House of Good Taste; *Acoustic Research, Inc.*, (*AR, Inc.*), whose exhibit in the Better Living Center features their own turntable and speaker systems, along with a tuner, preamp, and amplifier from *Dynaco* of Philadelphia and cartridges by *Shure Bros.* of Evanston, Ill.; *Reevesound Co., Inc.*, Div. of Reeves Industries, who has devoted much time, equipment, and talent to the development and operation of several exhibits—notably those of Bell Telephone, Eastman Kodak, General Cigar, General Motors, Ireland, S. C. Johnson, Travelers Insurance, United Airlines, and Electric Power and Light. Other electronics and acoustics companies have designed and equipped at least two large auditoriums at the Fair: one at the Texas pavilion and another in the band pavilion facing the Avenue of Progress. Throughout the many theaters involved in dozens of the exhibits, there has been a tremendous amount of acoustical design and consulting, as well as equipment engineering.

Overseeing the security and safety of the Fairgrounds exhibitors and visitors, the *Pinkerton's National Detective Agency* is using a \$250,000 communications system designed jointly by World's Fair Fire Chief Thomas P. O'Brien and *Bell Telephone Co.* engineers. In addition to the ordinary communications sets used by regular police and fire departments, the elaborate Pinkerton system has interconnections with public and private telephones all over the Fairgrounds. Special "nixie" lights show the operators and dispatchers the source of any call immediately. The network is one of the most elaborate ever developed for public safety purposes.

Conclusion

There are probably countless other companies, large and small, taking part in or contributing to electronics at the Big Fair. We've brought you up-to-date on those we've seen so that, on your trip to the Fair, you can be watching and taking note; you'll probably see electronic feats that will surprise you. And you're bound to come away with a better appreciation of just how vast our field is and how effectively electronics is helping to shrink the boundaries of the modern world. ▲



Fig. 26. Study booths in Audiovisual Center give insight to future teaching techniques.



TUNER REPAIRS

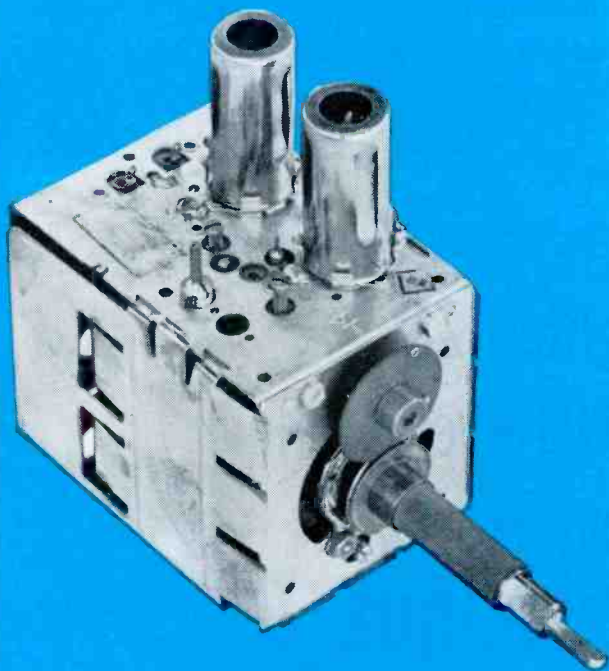

\$9.50

FOR COMPLETE OVERHAUL

Includes ALL parts (except tubes)
ALL labor on ALL makes

24-HOUR SERVICE with FULL YEAR WARRANTY

Sarkes Tarzian, Inc., largest manufacturer of TV and FM tuners, maintains two completely-equipped Service Centers to serve YOU. Both centers are staffed by well-trained technicians in this specialized field and are assisted by engineering personnel to assure you of FAST, DEPENDABLE service.

Ⓢ Tarzian-made tuners—identified by this stamping—received one day will be repaired and shipped out the next. A little more time may be required on other makes. Every channel is checked and re-aligned per manufacturer's specifications, not just the channels which might exist in any given area.

You get a 12-month guarantee against defective workmanship and parts failure due to normal usage. Cost to you is only \$9.50 and \$15 for UV combinations, including all labor and parts except tubes. No additional costs. No hidden charges. All tuners repaired on approved, open accounts. You pay shipping. Replacements on tuners beyond practical repair are available at low cost.

When inquiring about service on other than Tarzian-made tuners, always send TV make, chassis and Model number. Check with your local distributor for Sarkes Tarzian replacement tuners, parts, or repair service. Or, use the address nearest you for fast factory repair service.



SARKES TARZIAN, INC.

TUNER SERVICE DIVISION

See your distributor, or use the address nearest you

537 South Walnut St.,
Bloomington, Indiana
Tel: 332-6055

10654 Magnolia Blvd.,
North Hollywood, Calif.
Tel: 769-2720

Manufacturers of Tuners . . . Semiconductors . . . Air Trimmers . . . FM Radios . . . AM-FM Radios . . . Audio Tape . . . Broadcast Equipment

Circle 2 on literature card

July, 1964/PF REPORTER 9

WHY bother with makeshift twist-prong capacitor replacements?

When you substitute capacitor sizes and ratings, you leave yourself wide open for criticism of your work . . . you risk your reputation . . . you stand to lose customers. It just doesn't pay to use makeshifts when it's so easy to get the exact replacement from your Sprague distributor!

Get the right SIZE,
right RATING every time
with improved



SPRAGUE TWIST-LOK[®] CAPACITORS!

1,863 different capacitors to choose from!

The industry's most complete selection of twist-prong capacitors, bar none. Greater reliability, too. Exclusive Sprague cover design provides a leak-proof seal which permits capacitors to withstand higher ripple currents.

GET YOUR COPY of Sprague's comprehensive Electrolytic Capacitor Replacement Manual K-107 from your Sprague Distributor, or write Sprague Products Co., 105 Marshall St., North Adams, Massachusetts.



WORLD'S LARGEST MANUFACTURER OF CAPACITORS

68-122-63 R1

Circle 3 on literature card

publisher
Howard W. Sams

editor
Forest H. Belt

managing editor
George F. Corne, Jr.

associate editors
James M. Moore
Allen B. Smith
Stuart N. Soll
Norman D. Tanner

consulting editors
William E. Burke
Joe A. Graves
C. P. Oliphant

production manager
Robert N. Rippy

circulation manager
J. A. Vitt

circulation fulfillment
Pat Tidd, Mgr.
Katherine Krise, Ass't.
Cora La Von Willard, Ass't.

art directors
Gene La Rue
Robert W. Reed

advertising & editorial assistants
Hazel Boyer
Rebecca Clingerman

photography
Paul Cornelius, Jr.

advertising sales offices
Dave Milling, advertising sales manager

midwestern
Hugh Wallace
PF REPORTER
4300 West 62nd Street,
Indianapolis 6, Ind.
AXminster 1-3100

eastern
Gregory C. Masefield
Howard W. Sams & Co., Inc.
3 West 57th Street,
New York, N. Y.
MUrray Hill 8-6350

western
The Maurice A. Kimball Co., Inc.
2550 Beverly Blvd., Los Angeles 57, Calif.
DUmkirk 8-6178; and 380 Market Street,
Room 400, San Francisco 4, Calif. EXbrook 2-3365

Address all correspondence to
PF REPORTER, 4300 W. 62nd Street,
Indianapolis 6, Indiana



Copyright© 1964 by Howard W. Sams & Co., Inc.
PF REPORTER is a trademark of Howard W. Sams
& Co., Inc. No part of PF REPORTER may be
reproduced without written permission. No patent
liability is assumed with respect to use of
information herein. Acceptance of advertising does
not in any manner signify the products, policies
and services so advertised have been approved,
endorsed or recommended by this magazine.
Subscription Prices: 1 year—\$5.00, 2 years—\$8.00,
3 years—\$10.00, in the U.S.A., its possessions and Canada.
All other foreign countries: 1 year—\$6.00, 2 years—
\$7.00, 3 years—\$13.00. Single copy 50¢; back copies 65¢.

Indexed in *Lectrodex*.
Printed by the Waldemar Press Div.
of Howard W. Sams & Co., Inc.



PF REPORTER

including **Electronic Servicing**

VOLUME 14, No. 7

JULY, 1964

CONTENTS

SPECIAL COMMUNICATIONS SUPPLEMENT

- | | |
|--|----|
| Transistorized Mikes for Mobiles | 66 |
| A report with servicing hints on the construction and use of amplified mikes. | |
| Removing the Mystery from Modulators Edward M. Noll | 68 |
| This article will aid your understanding of modulators and modulation techniques. | |
| Radio Paging Leo G. Sands | 72 |
| A discussion of equipment and methods used in this rapidly expanding public service. | |

- | | |
|--|----|
| Heigh Ho . . . Come to the Fair! Forest H. Belt | 1 |
| Book Section—Our industry is on display at the World's Fair | |
| Letters to the Editor | 12 |
| The Electronic Scanner | 15 |
| The Troubleshooter | 21 |
| Symfact: Horizontal AFC (Synchronguide) See what happens to voltages and waveforms when troubles occur. | 25 |
| Key to Stereo Alignment Norman D. Tanner | 30 |
| Your multiplex customer deserves top performance; here's how to give it to him. | |
| Shortcuts That Waste Time Allan F. Kinckiner | 32 |
| Shop Talk—That next "timesaver" you try may cost you money! | |
| Foreign TV Systems | 34 |
| A handy guide to specifications and broadcasting standards overseas. | |
| Aerosols in Servicing Chemicals | 36 |
| Quicker Servicing—A roundup of handy chemical servicing aids that may save you many a headache. | |
| The High Cost of Employee Theft Dale Morey | 42 |
| Dollar and Sense Servicing—Shop owners are often victimized by dishonest employees. Are you? | |
| Notes on Test Equipment Stephen Kirk | 46 |
| Lab reports on EICO 3" Model 430 Oscilloscope, Heath Model IT-12 Signal Tracer, and Mercury Model 301 Combination VOM-Tube Tester-Rejuvenator. | |
| Product Report | 60 |
| Free Catalog & Literature Service | 64 |
| Monthly Index on free literature card | |

ABOUT THE COVER

The Biggest Show on Earth this year is probably the New York World's Fair. Organized to provide a showplace for products of the world's markets, the Fair has much to interest all who make their living in the expanding field of electronics. The Book Section in this issue is devoted to the part our industry plays at the Fair.



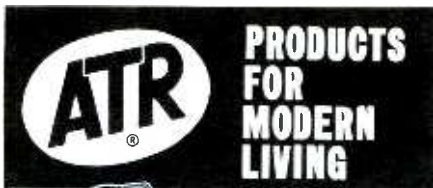

NOW...
THE FABULOUS
*** G. E. COMBO**

PLAYS ANYWHERE
ON 110 AC OR 12V DC
BATTERY CURRENT
For
Auto • Boat • Plane
Camps • Picnic • Trailer

ATR MODEL 12T-RME-1 INVERTER... \$39⁹⁵
*G.E. MODEL M110Y 11" PORTABLE TV \$99⁹⁵

*Available at G.E. TV Dealers

Both Only **\$139⁹⁰** Retail
THE **ATR** MODEL 12T-RME-1 ONLY ONE
OF A FAMILY OF FAMOUS DC-AC **INVERTERS**

Also NOW...

HAND WIRED—
NO PRINTED
CIRCUITRY

ATR ALL-TRANSISTOR
ULTRA COMPACT
UNIVERSAL MODEL 707



Karadio
IN DASH...
UNDER DASH...

Complete with variable tone control... R. F. stage
... Built-in speaker... and External speaker jack.

ATR MODEL 707... \$29⁹⁵ Retail



ATR ALL-TRANSISTOR
ROOF-MOUNT and
IN-DASH MODELS

TRUCK
Karadio
MODEL TR-720

FITS ALL TRUCKS • BOATS •
STATION WAGONS
INSTANT PLAY... POWERFUL

Complete with patented antenna-yoke assembly.
(U.S. Patent No. 3,087,118. Canadian Reg. 575,567)

ATR MODEL TR-720... \$44⁹⁵ Retail



ATR "A" Battery
ELIMINATOR

For Demonstrating and
Testing Auto Radios—
TRANSISTOR or VIBRATOR
OPERATED!
Designed for testing D.C.
Electrical Apparatus on Reg-
ular A.C. Lines.

MA Y ALSO BE USED AS A BATTERY CHARGER
MODEL 610C-ELIF... 6 volts at 10 amps. or 12 volts
at 6 amps. Shipping weight 22 lbs.

\$55⁰⁰

ATR AUTO RADIO and
COMMUNICATION

LONGER-LIFE
VIBRATORS

"The Best by Test!"



SEE YOUR ELECTRONIC PARTS DISTRIBUTOR OR
WRITE FACTORY FOR LITERATURE & DEALER PRICES
ATR ELECTRONICS, INC.
Quality Products Since 1931
St. Paul, Minnesota 55101—U.S.A.

Circle 4 on literature card

Letters to the Editor

Dear Editor:

In connection with the Color TV Test Generators chart on page 100 of your November issue, your readers may be interested to know that our Model 1076 has been modified to present a keyed-rainbow display instead of the simple rainbow pattern of earlier production runs. Also, they will want to know that the Model 1074 unit furnishes a single-bar NTSC-type signal, instead of the rainbow type indicated in the chart.

HENRY H. TEPLITZ
Stral Advertising Co., Inc.
Agency for B & K Mfg. Co.
Div. of Dynascan Corp.

Thanks, Tep. Our readers will also be interested in the modification kit that will convert the older Model 1076's to keyed rainbow (see pages 69-70 of the April issue.)—Ed.

Dear Editor:

In the "Guide to Communications Antennas" on pages 76 and 77 of your April issue, I notice that Mosley is not mentioned. I'd like to point out that Mosley is one of the largest suppliers of these types of antennas.

CARL E. MOSLEY
President & Treasurer
Mosley Electronics, Inc.
Bridgeton, Mo.

Dear Editor:

In the communications antenna chart in your April Communications Supplement, you failed to mention that Antenna Specialists of Cleveland is the world's largest manufacturers of communications antennas.

HENRY B. KREER
for Antenna Specialists
Cleveland, Ohio

Our apologies, gentlemen. Readers take note that both these prominent companies build several of the types shown in the "Guide to Communications Antennas" in our April Communications Supplement.—Ed.

Dear Editor:

I enjoyed Allan Kinckiner's April article "Tough Dogs in Synchronizers." I know another point that might interest your readers. In chassis using fixed oscillator coils (RCA in particular), I replace the coil with the same part used in the KCS98 chassis—the coil core has a knob on it, that was used for a hold control. This saves me a lot of trouble when trying to align the coil. The RCA part number is 79966, but a Thordarson HS-7 or equivalent will do the job.

FRED L. HIGH
Danville, Ill.

Thanks, Fred. This coil may also be a bit more stable, and might be a worthwhile circuit change. Make sure the correct type of capacitor is used.—Ed. ▲

1

Genuine, fresh Little Devil* resistors (on "Tally Tape" or in Cabinet Assortments)

2

Quality 2-watt pots. Type AB

Gold-bonded germanium diodes at "entertainment diode" prices.

3 WAYS TO MAKE SURE IT STAYS FIXED

You're always safe, always sure with any of these three quality replacements. Why be otherwise? Repair jobs that boomerang cost you hard-earned profit. Little Devil® resistors come in 1/10, 1/4, 1/2, 1, and 2 watts from 2.7 ohms to 22 Megs... AB Pots from 50 ohms to 5 Megs in several shaft lengths and styles... gold-bonded diodes in ninety 1N types off the shelf.

Call your distributor for the latest Ohmite Stock Catalog 30.

Be right with



Circle 5 on literature card

An aerial photograph of a winding road through a forested area. A large, complex metal antenna structure, consisting of multiple vertical poles with horizontal arms, is mounted on a white mobile research unit truck. The truck is positioned on the road, and the antenna extends upwards and outwards, dominating the upper half of the frame. The background shows a dense forest and a winding road that curves through the landscape.

FINCO'S

*9 Mobile Research Units
have traveled over
3,000,000 miles to conduct
13,833 "side-by-side"
performance tests
with competitors*

*The **FINCO** TV
Antenna is
always best!*

Want Proof?

*See your **FINCO** Distributor or write us.*

**THE
FINNEY
COMPANY
Bedford
Ohio**

Circle 6 on literature card

July, 1964/PF REPORTER 13

EXCITING

EXCITING

NEW LINE!

NEW SOUND!

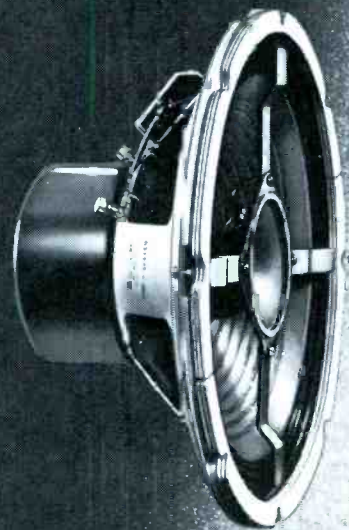

QUAM

FULL FIDELITY HI-FI SPEAKERS

Slim-line styling! Ceramic magnets! Superb reproduction over the full audio spectrum! Complete choice: coaxials, extended range, tweeters, woofers! The new Quam hi-fi line is as modern as tomorrow—and it's designed to offer the *serviceman* a top-quality product at a *list* price that's lower than others' "audiophile net." (Quam never advertises net prices—to protect your mark-up!)

Use Quam Hi-Fi Speakers in new systems, as extension speakers in existing hi-fi systems, and as replacement improvements in stereo consoles. They'll open your way to exciting new sales!

Write for your free copy of the new Quam Hi-Fi Catalog HF-64.

QUAM-NICHOLS COMPANY • 234 East Marquette Road • Chicago, Illinois 60637

Circle 7 on literature card



The Electronic Scanner

news of the servicing industry

Two New Factories



Robert D. Raynor, president of **Clear Beam Antenna Corp.**, revealed expansion plans which include construction of a new 100,000-square foot plant in California and a newly established manufacturing facility in Chicago, Ill. The California plant is being constructed on a 10-acre site in Chatsworth, a suburb of Los Angeles. The new facility will enable the TV and communications antennas firm to serve more efficiently the West Coast area.

AFC For UHF



A UHF tuner with automatic frequency control was announced recently by **Oak Manufacturing Co.** The AFC feature locks the oscillator circuit to the desired signal and eliminates drift.

The new tuner, developed primarily for use in color sets and remote controlled black-and-white receivers, has the same detent and features used in VHF tuners. Thus, the viewer can snap-in any of the 70 UHF channels. Continuous tuning has been used with UHF tuners in the past.

To Build New Plant



Corning Glass Works has announced it will build a 250,000-square-foot plant, on a 107-acre site two miles west of Bluffton, Ind. The new plant is expected to start producing glass for color television tubes early in 1965, and will employ approximately 300 persons. Corning will continue manufacturing operations at its other television-glass plants in Albion, Mich. and Corning, N.Y.

Plant Expansion



An additional 20,000 square feet of floor space has been added to the Addison, Ill. plant of **Jensen Industries**. The new facilities will be used primarily for expanded production of ceramic stereo cartridges.

Plans New Plant



B. B. Grossman, president of **International Electronics Corporation**, has announced plans for construction of a new 40,000-square foot plant, in Melville, Long Island, N.Y. The new building, expected to be completed by next Fall, will house the firm's expanded processing and packing operations for electron tubes, semiconductors, and other electronic components. ▲

GOOD NEWS FOR EASTERN TV SERVICEMEN...

CASTLE TV TUNER-EAST HAS MOVED TO NEW LOCATION WITH IMPROVED FACILITIES

In Long Island City near Postal Concentration Center to provide faster service by mail.

All other U.S. and Canadian Servicemen will get the same fast service from **CASTLE-CHICAGO** and **CASTLE-CANADA**.

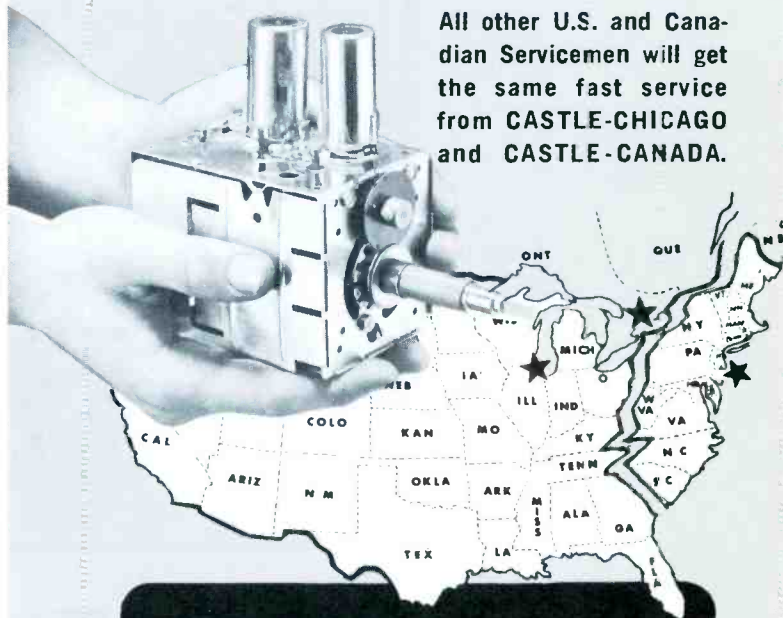

ALL MAKES

ALL LABOR AND PARTS (EXCEPT TUBES)*

ONE PRICE

995

THIS ONE LOW PRICE INCLUDES ALL UHF, VHF AND UV COMBINATION* TUNERS

Simply send us your defective tuner complete; include tubes, shield cover and any damaged parts with model number and complaint. 90 Day Warranty.

Exact Replacements are available for tuners unfit for overhaul. As low as \$12.95 exchange. (Replacements are new or rebuilt.)

*UV combination tuner must be of one piece construction. Separate UHF and VHF tuners must be dismantled and the defective unit only sent in.

Pioneers In TV

Tuner Overhauling



CASTLE

TV TUNER SERVICE, INC.

EAST: 41-90 Vernon Blvd., Long Island City I, N. Y.

MAIN PLANT: 5701 N. Western Ave., Chicago 45, Illinois

CANADA: 136 Main Street, Toronto 13, Ontario

*Major Parts are additional in Canada

Circle 8 on literature card

Available Now

RCA Victor Color TV

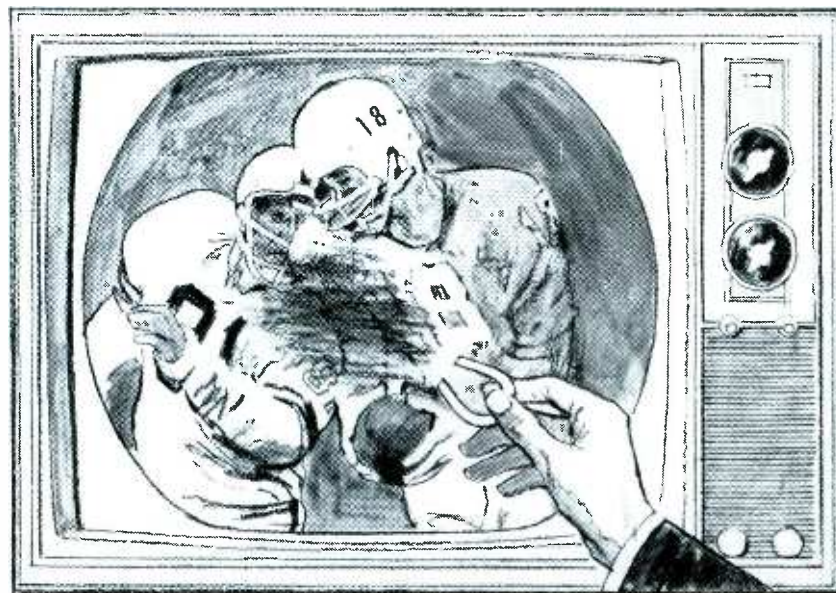

Magnetism can cause impurities...

in the color picture—a weak pocket magnet can easily demonstrate this effect. In the home, as you know, magnetic distortions may be caused by moving the set in relation to the earth's magnetic field or they can sometimes be caused by nearby electric appliances.

To “cancel” the magnetism and restore natural color...

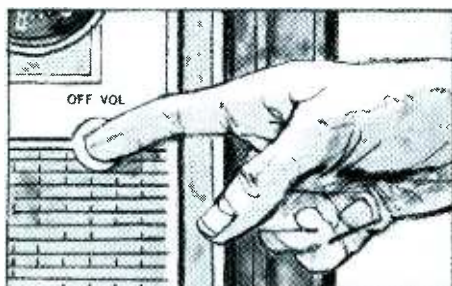

simply turn off the set, let it cool 4 or 5 minutes, then turn it back on. That's all—no more need for a separate degaussing coil! The RCA Victor Automatic Color Purifier acts *every time the set is turned on* from a cool start. Color is bright, sharp, true—free of impurities caused by magnetism. The RCA Victor Automatic Color Purifier also removes unwanted color areas from the black and white picture. Here's another major “first” from RCA Victor that can give you a profitable advantage in extra sales . . . and in service savings!

degausses itself!

Gives you 3 big advantages!

1

Floor models always ready for best color picture!

Ever lost a sale because your floor demonstrator needed degaussing? The RCA Victor Automatic Color Purifier cleans up that problem . . . the set always shows unsurpassed natural color. And with a swivel or caster model, you can quickly demonstrate how color TV can now be moved about without worry of magnetic distortion!

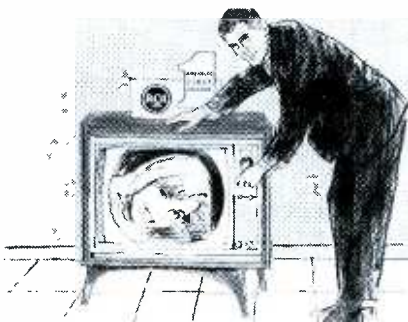

2

Faster, easier setup in customer's home!

The RCA Victor Automatic Color Purifier eliminates the need for you to perform time-consuming degaussing when you deliver the new Mark 10 color TV set. This makes setup faster, easier . . . freeing you for more profitable TV servicing. The Automatic Color Purifier is standard on all Mark 10 models except the price leaders.

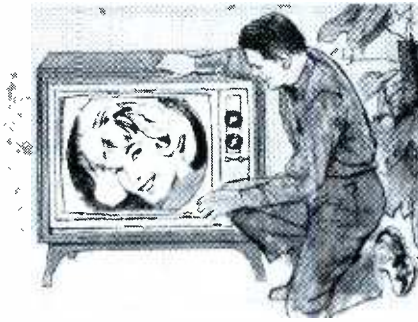

3

Reduces unprofitable callbacks!

The RCA Victor Automatic Color Purifier will end those degaussing "nuisance" calls that can eat up service time and profits. They're a nuisance to customers, too! Increased customer satisfaction is sure to follow from this new RCA Victor "first"—and remember, a satisfied customer is very often your best salesman.



Make sure you get your share of the big Color TV sales forecast for '65...get with RCA Victor!



The Most Trusted Name in Television

Tmk(s)®

SEE THE RCA COLOR TV CENTER AT THE WORLD'S FAIR

July, 1964/PF REPORTER 17

Winegard COLORTRON Antenna

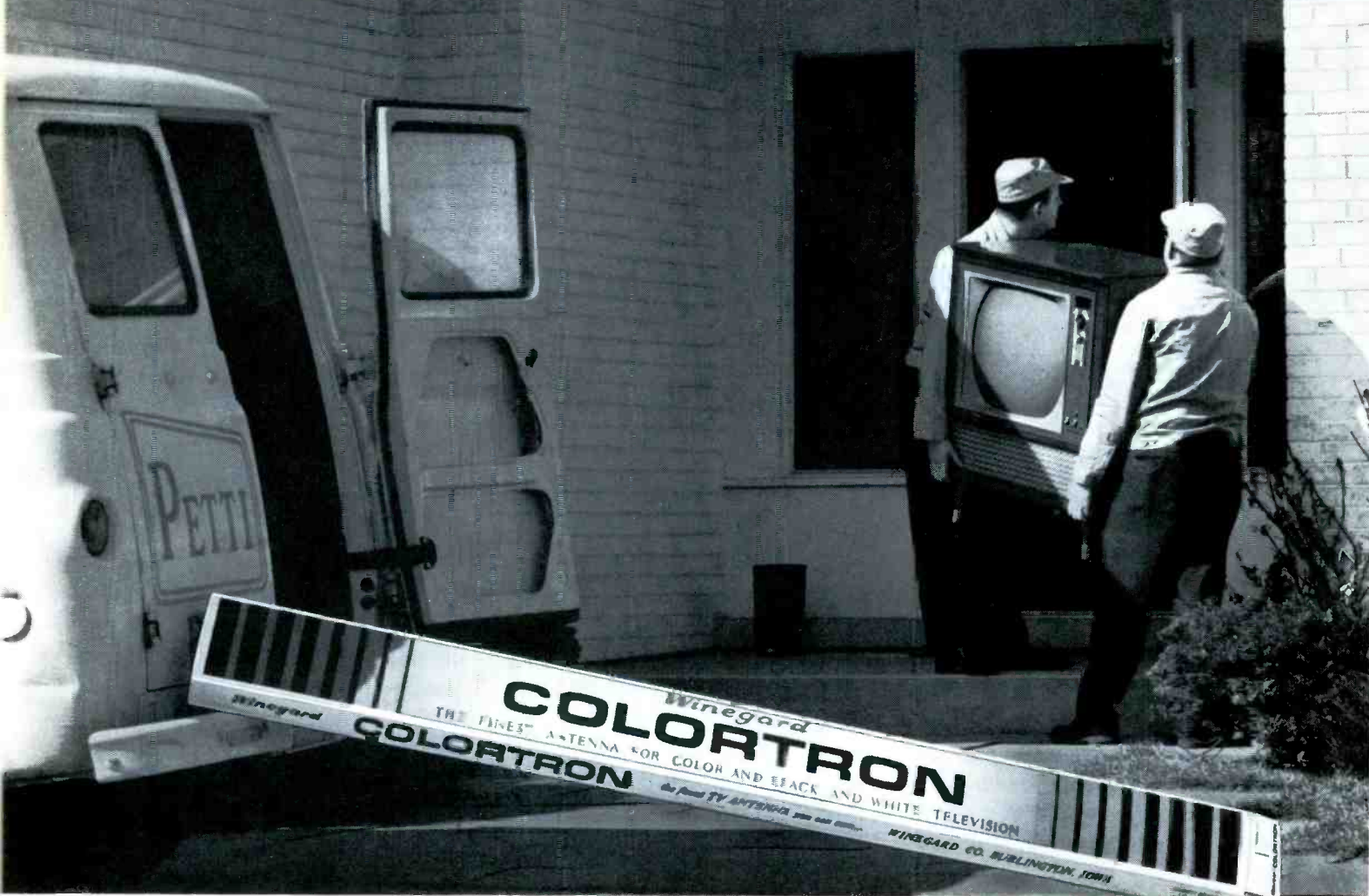

The Colortron Antenna's "BALANCED DESIGN" is the Winegard secret of superior color reception!

It takes a combination of high gain, accurate impedance match, complete band width and pinpoint directivity to make the perfect color antenna. Only the Winegard Colortron gives you all 4 with **BALANCED DESIGN**.

What is Balanced Design? It's not enough to design an antenna for high gain alone and expect good color reception. A high gain antenna without *accurate impedance match* is ineffective. Or an antenna with *good band width* but *poor directivity characteristics* is unsuitable for color. The Winegard Colortron is the one antenna with *balanced design*, excellence in *all* the important characteristics that a good color antenna requires.

For example:

Gain and Bandwidth—A superior color antenna must have high gain and complete bandwidth as well. But the response must be *flat* if it is to be effective. Peaks and valleys in the curve of a high gain antenna can result in acceptable color on one channel and poor color on another.

No all-channel VHF-TV antenna has more gain with complete bandwidth across each and every channel than the Colortron. Look at the Colortron frequency response in this oscilloscope photo.

Note the consistent high gain in *all* channels. Note the absence of suck-outs and roll-off on end channels. The flat portion of the curve extends on the low band from the channel 2 picture carrier past the channel 6 sound carrier. On the high band, it is flat from the channel 7 picture carrier to the channel 13 sound carrier. There is less than $\frac{1}{2}$ DB variance over any channel.

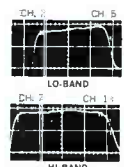

Impedance Match—the two 300 ohm "T" matched Colortron driven elements have far better impedance match than *any* antenna using multiple 75 ohm driven elements. The Colortron transfers *maximum* signal to the line without loss or phase distortion through mismatch. Winegard's "T" matched driven elements cost more to make, but we know the precision results are well worth the added manufacturing expense . . . because a mismatched antenna causes loss of picture quality which *might* get by in black & white, but becomes highly disturbing in color.

The oscilloscope photo here shows the Colortron VSWR curve (impedance match). No current VHF-TV antenna compares with it across all 12 channels.

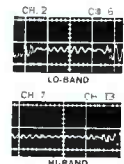

...made for color!



Directivity—Equally important for superior color pictures is freedom from interference and ghosts. Therefore, an antenna with sharp directivity and good signal-to-noise characteristics is necessary. Extraneous signals picked up at the back and sides produce objectionable noise and ghosts in black and white reception . . . frequently ruin color reception.

Winegard's Colortron has the most ideal directivity pattern of any all channel VHF antenna made. It has no spurious side or large back lobes . . . is absolutely dead on both sides. Colortron does not pick up extraneous signals, and even has a higher front-to-back ratio than a single channel yagi.

Look at this Colortron polar pattern. No other VHF-TV antenna has sharper directivity on a channel-for-channel comparison.

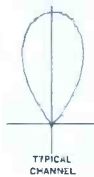

BALANCED DESIGN COLORTRONS HAVE SUPERIOR MECHANICAL FEATURES, TOO!

Every square inch of the Colortron has been engineered for maximum strength, minimum weight and minimum wind loading. Even the insulators are designed for low wind resistance. The result

is a streamlined, lightweight antenna that stays stronger longer. Colortrons have been wind tested to 100 mph.

Colortrons are simpler to put up, too. Easier to carry up a ladder and mount on a high mast. No extra weight and bulk to frustrate the antenna installer.

And, you can see the difference in quality when you examine a Winegard COLORTRON. The GOLD ANODIZED finish is bright weather-proof gold that *won't fade*, rust or corrode. It's the same finish specified by the Navy for military antennas. Full attention is paid to every detail.

Winegard Helps You Sell—does more national advertising than all other brands combined. When you sell Winegard, you sell a brand your customer knows . . . backed by a *written factory guarantee of satisfaction*.

It's not surprising that Winegard leads the field in the number of antennas installed with color sets. And Colortrons have been installed by the hundreds of thousands for black and white sets too—for the antenna that's best for color is best for black and white as well. Why don't you try a *balanced design* Colortron and see for yourself?

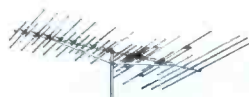

COLORTRON ANTENNA
Model C-44 • Gold Anodized • \$64.95

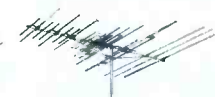

COLORTRON ANTENNA
Model C-43 • Gold Anodized • \$51.90



COLORTRON ANTENNA
Model C-42 • Gold Anodized • \$34.95



COLORTRON ANTENNA
Model C-41 • Gold Anodized • \$24.95



Winegard Co.

3009-G KIRKWOOD • BURLINGTON, IOWA

Circle 9 on literature card



BUSS quick-acting Fuses

"Fast Acting" fuses for protection of sensitive instruments or delicate apparatus;—or normal acting fuses for protection where circuit is not subject to starting currents or surges.

BUSS

Write for BUSS
Bulletin SFB

BUSSMANN MFG. DIVISON, McGraw-Edison Co., St. Louis, Mo. 63107

1. Junction of M1 and L21 (should be about 290 ma).
 2. Pin 8 of V11 to ground (should be about 100 mu).
 3. Pin 9 of V9B to ground (should be about 34 ma).
- The prime suspect, whenever current is high, is the horizontal section.

Faulty rectifiers have been known to cause this trouble, too. It is also possible that the resistor is located physically where it can collect extra heat from other components. This could cause repeated failure.

Hot Stuff

I have a Sparton Model 52CM24 Chassis 23V5-2 in my shop. It is repaired, but not to suit me. I cannot get the cathode current on the 6CD6GA horizontal-output tube below 190 ma.

The set has a good picture, and all voltages (oscillator and output) are close to normal except for the grid of the 6CD6. This measures -12 to -15 volts instead of -43 volts shown in PHOTOFACT Servicer 309-17S. If I increase the horizontal drive very much the current goes over 200 ma.

The owner told me that when this set was new, it caused trouble by burning up the yoke plug. It also burned out the flyback and yoke once. Any ideas you can give me will be appreciated.

B. E. HERIFORD

Plummer, Idaho

The 190-ma reading you measured in the 6CD6 cathode is excessive; normal current for this tube is 140 ma. Try adjusting the linearity coil for minimum cathode current. With a scope, check the amplitude of the grid drive signal—it should be about 100 to 125 volts. If it's low, or shaped incorrectly, check the oscillator circuit. Check for leakage in the coupling capacitor to the 6CD6 grid, and check the resistors in the 6CD6 screen circuit and replace any that are out of tolerance. Be sure the B+ voltage is not too high—this could be one source of the problem.

BUSS: 1914-1964, Fifty years of Pioneering....



The Troubleshooter

answers your servicing problems

Repetition

I am another guy with a problem. I have a Philco Model UJ3702L, and every five to six weeks I have to replace the 5.6-ohm fusible resistor. This fuse develops a resistance of about 7 megohms. I cannot locate the defect that causes this condition. Can you offer a suggestion?

JIM AHEARN

Lincoln, Ill.

The symptoms indicate the chassis may be drawing a bit more than normal current. I suggest that you monitor the current at these points (PHOTOFACT Folder 511-2):

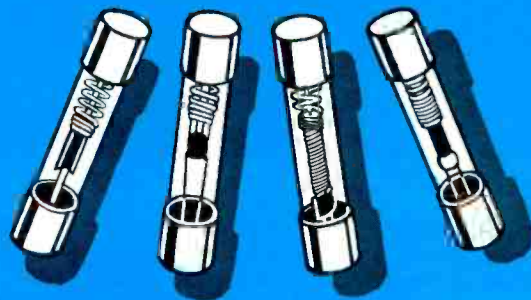
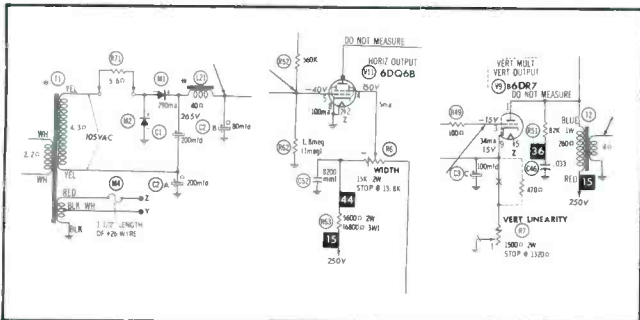

FUSETRON dual-element Fuses

time—delay type

"Slow blowing" fuses that prevent needless outages by not opening on motor starting currents or other harmless overloads—yet provide safe protection against short-circuits or dangerous overloads.

BUSS

Write for BUSS
Bulletin SFB

BUSSMANN MFG. DIVISON, McGraw-Edison Co., St. Louis, Mo. 63107

Circle 10 on literature card

BUSS MBO
1/4 x 1-1/4
inch

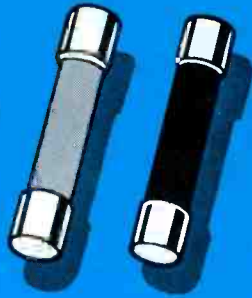

BUSS ABC
1/4 x 1-1/4
inch

BUSS

high interrupting capacity
Fuses

For the protection of circuits capable of delivering currents as high as 25,000 amps. at 125 volts or 10,000 amps. at 250 volts.

BUSS

Write for BUSS
Bulletin SFB

BUSSMANN MFG. DIVISION, McGraw-Edison Co., St. Louis, Mo. 63107

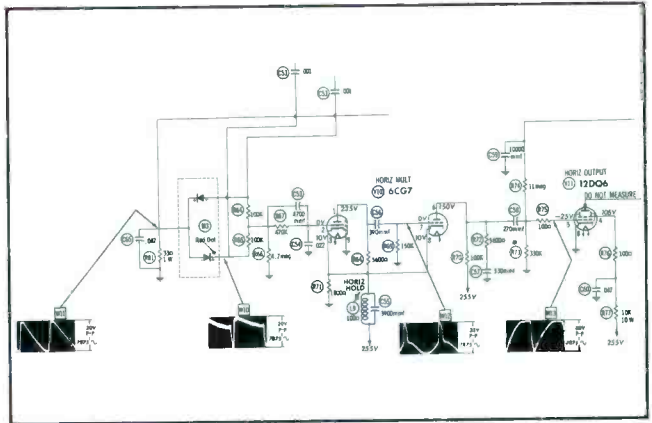

Just before the picture locks in, it looks like just a smear of light. Then when I turn the hold control just a fraction more, the screen blacks out.

I have checked voltages in the horizontal circuits, but I may be looking in the wrong place. This trouble is similar to one of the photos in "Visual Symptoms Tell A Story" in the December, 1962 PF REPORTER, except that the lines are very clear and extend all the way across the screen.

E. A. CAIN

Salem, Ohio

The symptoms in this receiver (PHOTOFACT Folder 350-1) indicate trouble in the horizontal AFC or oscillator circuits. Try grounding the AFC control point—pin 2 of V10—and see if a normal raster returns. If it does, try new AFC diodes and check C53, C54, C65, C56, R64, R65, R67, and R81. Common offenders are C51 and C52.

If the raster doesn't return, check the horizontal oscillator and output. Make sure the ripple on the B+ line feeding the oscillator is less than 1 volt peak-to-peak. ▲

....New Developments in Electrical Protection

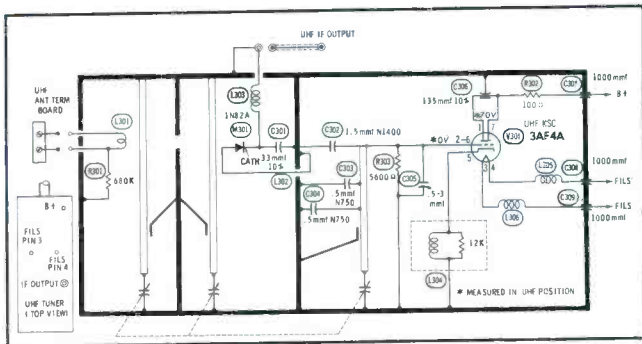

UHF Problem

I have a Westinghouse Chassis 494306 which has a peculiar picture on UHF. It is speckled so badly that you can hardly see it. I changed the 3AF3 several times to no avail. The sound is fine.

I would appreciate any advice you could offer.

MARTIN CECIL

Owensboro, Ky.

"Speckle" such as you describe is sometimes caused by a faulty 1N82A mixer crystal in the UHF tuner. If replacing it doesn't cure the problem, check R302 (PHOTOFACT Folder 593-3); this resistor occasionally increases in value and causes trouble of this nature. Also check R87, the 1800-ohm resistor in series with the B+ line to the UHF tuner.

Very Dim

I have an Admiral Model 14VP3C in my shop for repair, and I have tried just about everything. There is no picture but the audio is fine. The raster is very dim, but as I turn the horizontal hold control, bright horizontal lines appear.

**New! BUSS SPACE SAVER
PANEL MOUNTED FUSEHOLDER**

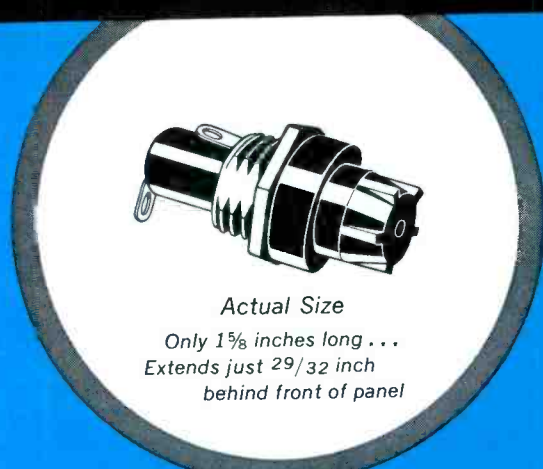

Actual Size

Only 1 5/8 inches long . . .
Extends just 29/32 inch
behind front of panel

- Fuseholder takes 1/4 x 1 1/4 inch fuses. Converts to 9/32 x 1 1/4 inch fuses simply by changing screw type knob. Holder is rated at 30 ampere for any voltage up to 250.

- Also available in military type which meets all requirements of MIL-F-19207A.

BUSS

Write for BUSS
Bulletin SFH-10

BUSSMANN MFG. DIVISION, McGraw-Edison Co., St. Louis 7, Mo.

Circle 10 on literature card

TV-RADIO SERVICE

 tubes 

YOUR NAME HERE

ETR 1290

TV-RADIO SERVICE

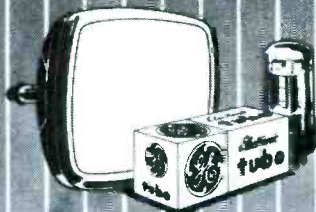

 **ELECTRONICS**

ETR 1566

TV-RADIO SERVICE



ETR 1569



ETR 1565



ETR 1568



ALL Radio-TV
service
clothing

PATTERN-PERFECT PICTURE SERVICE?

GENERAL ELECTRIC
Best Tubes for Your Set



ETR 3287



ETR 1291

 **ELECTRONICS**

TV RADIO SERVICE



ETR 1564



ETR 3288

TV-RADIO SERVICE

 tubes 

YOUR MESSAGE HERE

ETR 1556

G-E FIX-UP, DRESS-UP

Be "Best Dressed" at half the catalog price!

The better your shop looks, the better is the outlook for business. Customers prefer to do business at a shop that has a neat, "careful" look. It gives them confidence in your work. But time and use *can* and *do* affect appearance.

It may be just that time—when your outdoor signs are looking a bit under the weather, or perhaps you could use a display clock or thermometer to functionally dress up your shop. Need a new service hat or jacket?

For a limited time, General Electric is sponsoring a "Fix-up, Dress-up" campaign to make you, the dealer, "best dressed" at half price. Choose from over 25 items, including signs and display materials, clocks and thermometers, and a complete selection of wearing apparel—hats, shirts, pants, caps, jackets—ALL AT 1/2 THEIR CATALOG PRICE. All special-priced display and clothing items may be obtained on a cash basis by mail or directly from your distributor with the purchase of G-E tubes.

CHOOSE FROM THESE ITEMS:

ETR 1290	SIGN, outdoor, illum., 2 face, 24" x 48"
ETR 1566	SIGN, nameplate, outdoor, 2 face, 48" x 36"
ETR 1565	SIGN, flange, outdoor, 2 face, 15" x 12"
ETR 1564	SIGN, tack-on, outdoor, 14" x 42"
ETR 1556	SIGN, indoor, with changeable letter kit (37" x 14")
ETR 1291	CLOCK, indoor, illum., 16" dia.
ETR 1568	THERMOMETER, indoor/outdoor, 12" dia.
ETR 1569	BACKDROP, corrugated, 36" x 24" (2 per carton)
ETR 3288	TUBE CARTON, giant, 7 1/8" x 17 5/8"
ETR 3287	DECAL, 1 side, back stick, 16" x 12"

Catalog Price	Special Price
\$168.75	\$84.37
27.00	13.50
2.25	1.13
2.70	1.35
27.50	13.75
14.95	7.48
5.95	2.98
2.00	1.00
.35	.18
.25	.13

AND

You may use form ETR 1499B for ordering *any* radio-TV service clothing at half price. Obtain this form from your local distributor or complete and mail the coupon below. Please check the box requesting ETR 1499B.

**Send To: General Electric Co., Dept. B
3800 N. Milwaukee Ave.
Chicago, Illinois 60641**

Name _____

Address _____

City _____ Zone _____ State _____

I enclose \$_____ in check or money order for the following half-price items, including applicable local and/or state sales/use taxes:

- | | |
|-----------------------------------|-----------------------------------|
| <input type="checkbox"/> ETR 1290 | <input type="checkbox"/> ETR 1291 |
| <input type="checkbox"/> ETR 1566 | <input type="checkbox"/> ETR 1568 |
| <input type="checkbox"/> ETR 1565 | <input type="checkbox"/> ETR 1569 |
| <input type="checkbox"/> ETR 1564 | <input type="checkbox"/> ETR 3288 |
| <input type="checkbox"/> ETR 1556 | <input type="checkbox"/> ETR 3287 |

Please send me service clothing order form ETR 1499B.

Progress Is Our Most Important Product

GENERAL  ELECTRIC



Tips for Technicians

Mallory Distributor Products Company
A division of P. R. Mallory & Co. Inc.
Indianapolis, Indiana 46206

How to break the capacitor replacement habit

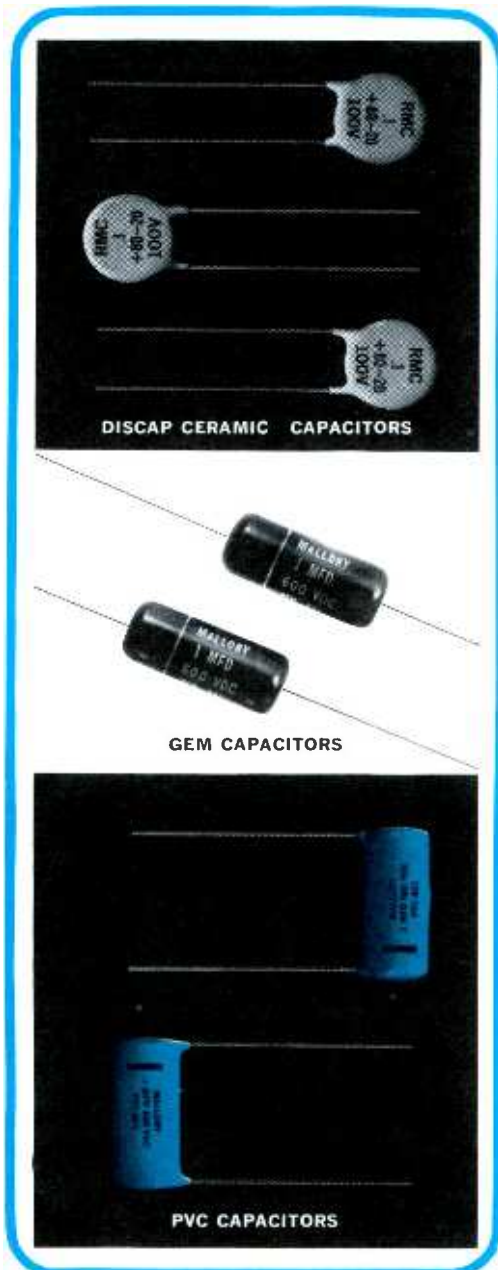

Ever hear of "original capacitor-itis?" It's a habit that has been plaguing service technicians for decades. Here's what it means. If you need to install a new capacitor, you automatically get one *exactly* like the one that was in the circuit. The original capacitor, in theory, is the best one for the job.

But... it ain't necessarily so. And breaking the habit can often save you money.

When you need to replace a mica capacitor, for instance... consider ceramics. They'll often do a better job, for less cost (and we mean up to $\frac{1}{2}$ as much) than mica capacitors in most circuits. Ceramic capacitors often give you an extra safety factor in voltage rating, too; except for a few miniature and special types, their standard rating is 1000 volts DC. Some up to 30 KV. You can almost always replace mica with ceramic. But... you seldom can replace ceramic with mica, because ceramics are often selected by original equipment designers for temperature compensating functions.

Don't forget to think of ceramics, too, when you need to replace a molded tubular capacitor. They cost about the same or even less, value for value. If you've got 'em, you can use 'em.

Here are two tips that may save you time and money.

First... when you're replacing a capacitor, all you need 9 times out of 10 is the same microfarads and voltage rating. Not a round one. Or a square one.

Second... when you need capacitors, see your Mallory Distributor. He carries not only a complete line of Mallory Discap[®] ceramic capacitors... the finest in the industry... but also Mallory GEM[®] and PVC[®] Mylar* tubulars. Plus Mallory electrolytics, batteries, volume controls, switches, semi-conductors. All of them at famous Mallory quality, at sensible Mallory prices.

*Registered Du Pont Trademark



Synchroguide

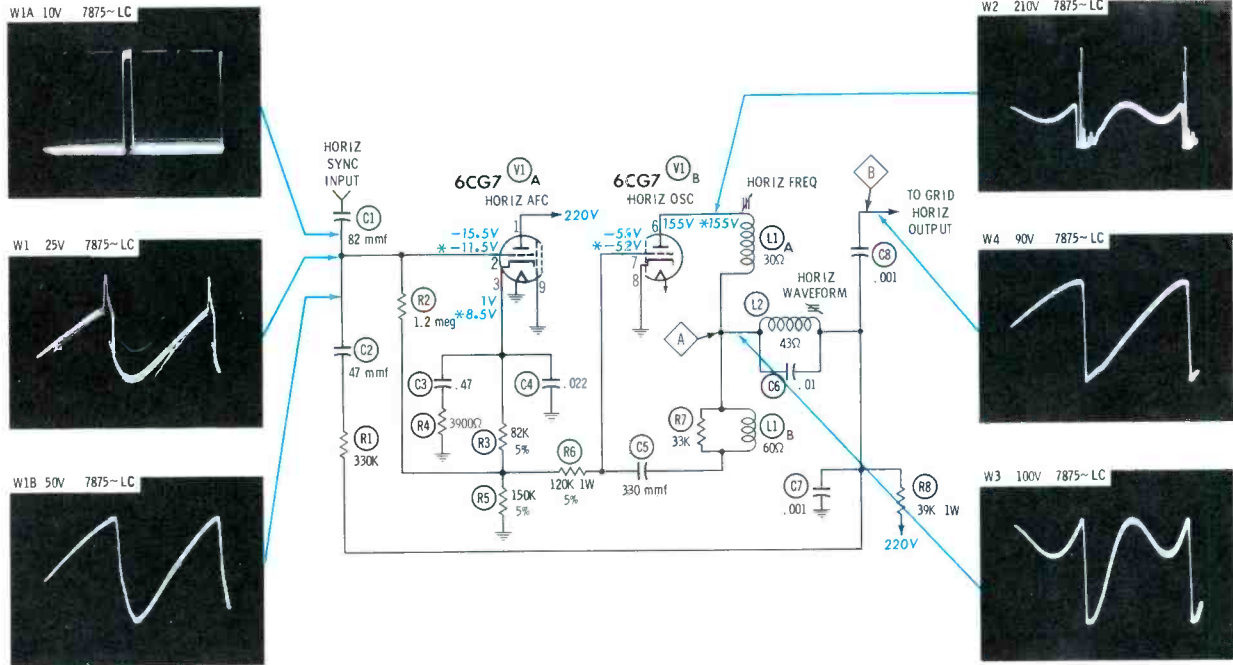

DC VOLTAGES taken with VTVM, on inactive channel; antenna terminals shorted. *Indicates voltages taken with signal present—see "Operating Variations."

WAVEFORMS taken with wideband scope; TV controls set for normal contrast (50 volts p-p at CRT). Low-cap probe (LC) used to obtain all waveforms.

Normal Operation

Synchroguide circuit shown here (from RCA Chassis KCS102B), or variations thereof, can be found in many receivers produced in last decade. Circuit is also known as pulse-width frequency control. Free-running frequency of blocking oscillator V1B is determined by L1A, L1B, and RC time constant of C5-R6-R5. Feedback to sustain oscillation is from secondary winding L1B via coupling capacitor C5. Tank circuit L2-C6 causes sine wave to be superimposed on sawtooth plate signal, thus stabilizing oscillator. Network C7-R8-C8 produces sawtooth waveshape necessary to drive horizontal-output tube. Positive-going sync pulse from separator stage is coupled to grid of V1A via C1; positive-going sample sawtooth voltage (obtained from output circuit of V1B) is also supplied to grid via amplitude-reducing coupling components R1, C2. Top of R5 is point where DC oscillator-control voltage develops. DC voltage here is set by tube conduction through R5, which depends on duration of signal to grid. C3, R4, and C4 in cathode circuit prevent AFC "hunting." Action of control tube V1A is thus: Tube is biased to conduct only on upper portion of grid-input waveform. Both signals (sync and sample) combine at grid. If sample sawtooth arrives late in relation to sync pulse (oscillator running slow), V1A conducts for longer period, causing increased positive cathode voltage. V1B grid voltage consequently becomes less negative, and oscillator is forced to speed up. Reverse action takes place if oscillator frequency tends to increase.

Operating Variations

PIN 2

DC grid voltage ranges from -11.5 volts with signal to -15.5 volts without signal (due to sync pulse). Value can be shifted either direction with frequency coil, though picture is still locked in. Voltage with *misadjusted* coil varies from -25 to -8 volts (picture out of sync). W1 is combined waveform; W1A (10 volts) is horizontal sync pulse taken at end of C1 with it disconnected from grid of V1A; sample sawtooth W1B (50 volts) is taken with C2 disconnected from grid.

PIN 3

DC Voltage *without signal* varies from +9 volts to -5 volts with adjustment of frequency slug (lowering frequency makes DC voltage more positive). 8.5 volts *with signal* is from increased conduction through V1A. Waveform at this point (see Symptom 1) is ill-defined sawtooth with only 1-volt amplitude.

PIN 7

Voltage here drops from -55 to -52 volts when signal is present; positive shift reflects increased conduction of V1A.



This is important scoping point during horizontal alignment. Easy method is to short L2-C6 with jumper, adjust L1A for floating horizontal bars; remove jumper and adjust waveform slug L2 for normal waveform similar to W3—with equal peaks.

Horizontal Flutter

SYMPTOM 1

Frequency Control Critical

C4 Open

(Antihunt Filter—.022)

Symptom Analysis

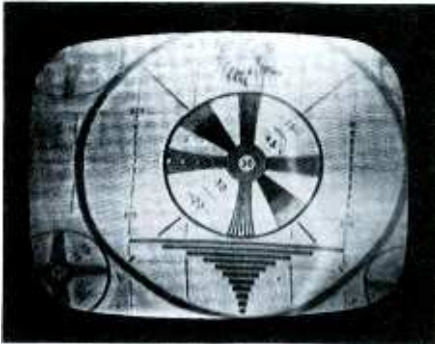

Nervous flutter or jitter is present over entire screen. Setting of horizontal frequency control is critical, adjustment won't cure problem. Picture is fairly stable at times; horizontal blanking bar appears intermittently. Definite indications of AFC or oscillator trouble.

Waveform Analysis

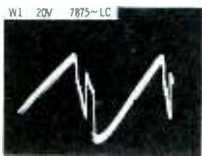

W1 has necessary "ingredients" (sync and sawtooth) for proper waveform; however, they aren't in correct phase—sync pulse is down right side of sawtooth. Waveform at cathode of V1A offers good clue to trouble—looks like grid signal, and has 7-volt amplitude. Normal signal here is only thick, 1-volt sawtooth (see waveform). Normal W3 (not shown) indicates oscillator circuit is normal, tying trouble to defect in AFC section.

Voltage and Component Analysis

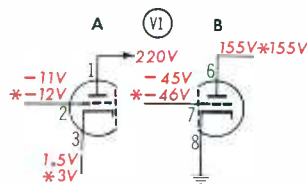

DC voltages, with or without signal, don't offer definite clue to trouble. V1A cathode voltage is down slightly, but it can vary normally over wide range with setting of L1A. C4 filters DC voltage and helps stabilize frequency during quick changes in conduction time of V1A. Normally C3 and C4 charge during tube conduction, discharge while tube is cut off. With C4 open, cathode voltage (and thus control voltage) fluctuates fast enough to cause rapid jitter. Only filter network now in action is C3-R4, which presents too-short time constant.

Best Bet: Scope will pinpoint this trouble.

Horizontal Sync Lost

SYMPTOM 2

Width Not Affected

C6 Decreased in Value

(Waveform-Coil Capacitor—.01)

Symptom Analysis

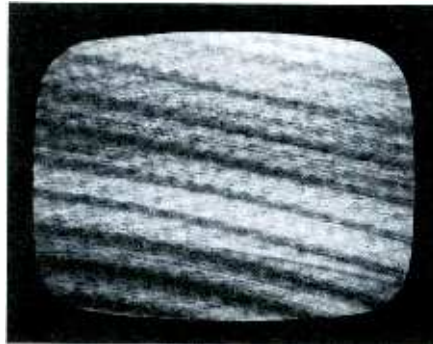

Picture can be brought almost into sync by adjusting frequency coil. Turning slug further causes squегging (Christmas tree). Customer may complain of losing sync temporarily when changing channels. Trouble could be caused by weak horizontal sync pulses.

Waveform Analysis

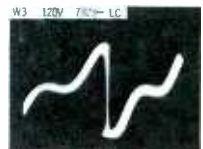
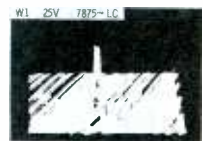

First check is at V1A grid. With oscillator off frequency, it's often necessary to open lead of C1 to view sync without distortion. Normal W1A clears separator. W1 (C1 connected) shows good sync at grid—pulse amplitude well above off-frequency sawtooth. W3 indicates trouble in oscillator: picture can be locked in with waveform coil, but correct W3 (equal peaks) can't be obtained at any setting of slug. Scope won't pinpoint, but does help isolate.

Voltage and Component Analysis

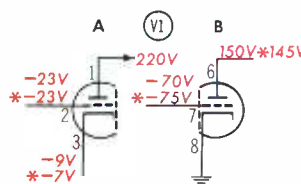

DC voltages on grid and cathode of V1A and grid of V1B, even though abnormal, don't help isolate trouble—they'll change any time oscillator is this far off frequency. Plate voltages might offer clue; however, in this instance they're within range. Next step to isolating trouble is to jumper L2-C6. Adjusting L1A results in normal floating horizontal bars, so trouble must be in waveform network. Wrong value (.005) of C6 in tank circuit causes reaction throughout oscillator and AFC. C6 is common offender in this circuit.

Best Bet: Trace with scope then component check.

Width Decreased

SYMPTOM 3

Sync Okay

R8 Increased in Value

(Plate Supply Resistor—39K)

Symptom Analysis



Picture looks normal except for insufficient width. Adjusting width coil (in flyback circuit) doesn't help, so defect could be in horizontal output or width circuit. Adjusting horizontal frequency coil kills raster, strong hint of trouble in oscillator section.

Waveform Analysis

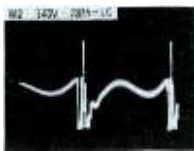

Best starting test is of drive signal to output tube. Sawtooth in W4 is good, but 60-volt amplitude is insufficient — probably weak oscillator output. Dip at start of waveform is insignificant — sweep portion of slope is linear. Shapes of W3 and W2 are acceptable, but low amplitudes again suggest weak oscillator. Picture is in sync, so AFC is probably okay. Scope and visual observations give good indications of trouble in oscillator.

Voltage and Component Analysis

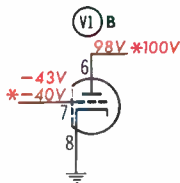

Voltages, coupled with waveform amplitudes, pinpoint defect in plate circuit of oscillator. Normal 155 volts on plate is down to 100 volts, and grid voltage of V1B is down nearly 10 volts due to reduction of feedback signal from plate circuit. Combination of clues indicates R8 as culprit: plate voltage low, output signal low, oscillator frequency okay. Here, 1-watt R8 has increased to 120K; if it goes further, focus is lost, width decreases more, and oscillator may become inoperative. It's always good idea to check R8 in this circuit.

Best Bet: Proper scope checks; then VTVM.

Picture Narrow, With Foldover

Loss of Horizontal Sync

C5 Leaky

(Oscillator Feedback Capacitor—330 mmf)

SYMPTOM 4

Symptom Analysis

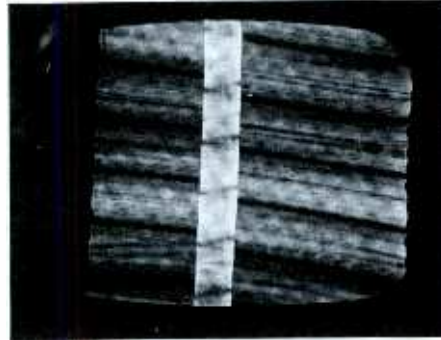

Reduced width, degraded focus, and foldover all seem to indicate trouble in horizontal output, damper, and HV sections. Picture is out of sync, too, so trouble could be in oscillator stage, either directly or as result of defect in output sections.

Waveform Analysis



When width is poor, or foldover present, always check drive signal at Point B. W4 is "double-humped," indicating defect is prior to output stage; loss of time checking that stage is avoided. W3 is also distorted and gives clue that oscillator is double-triggering. Extra spike is also in W2 (not shown). Sync-pulse problem rarely causes foldover, and W1 proves incoming sync is good—sample sawtooth naturally has added spike from oscillator.

Voltage and Component Analysis

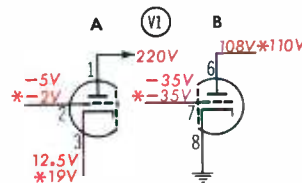

Negative grid voltage on V1A is low; cathode voltage is high; voltages on grid and plate of V1B are low. Best clue is -35 volts on grid of V1B (normally around -55 volts); plate voltage (110 volts) is probably lowered from overconduction of V1B due to positive shift in grid bias. Value of R8 is okay, but it is hot, confirming excessive current. V1A cathode voltage is high, but not by 20 volts—which is amount of change in grid voltage of V1B. DC path through leaky C5 is thus most logical cause of bias shift. Dynamic check is in order.

Best Bet: Scope to isolate; VTVM to confirm.

Horizontal Rolling

SYMPTOM 5

Vertical Not Affected

C1 Open

(Sync Coupling Capacitor—82 mmf)

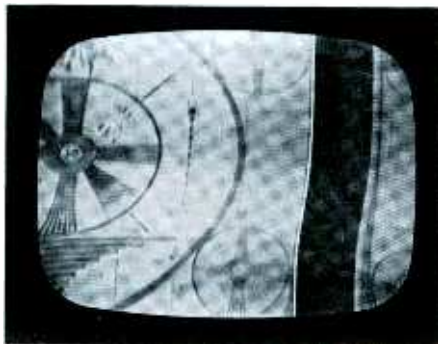

Roll can be slowed by critical setting of frequency coil, but picture will start shaking, then roll again. Vertical isn't affected, so horizontal sync distortion is most likely cause of trouble. Symptom is typical when pulse to AFC section is weak or missing.



Waveform Analysis

With horizontal sync poor, and vertical sync okay, first check point is input to AFC stage. W1 has clean sawtooth, but no sync pulse, and 50-volt amplitude is twice normal. Moving scope to separator side of C1 immediately pinpoints open C1—clean horizontal sync pulse with proper amplitude is present there. Confirming check is W1A, taken with C1 disconnected—only scope trace is present at this point. Only three scope checks are needed.

Voltage and Component Analysis

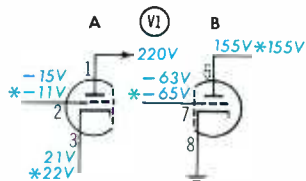

High cathode voltage of V1A, increased negative voltage at grid of V1B offer only clues. Open C1 causes change in load for sample signal, thus larger amplitude of sample sawtooth at AFC grid. Oversize sawtooth increases average conduction through V1A and raises cathode to 25 volts. Same change affects plate circuit of V1B (through R1-C2 path). Consequent frequency change causes increase of grid voltage (-65 volts) for V1B. Under most circumstances, V1B grid would have "followed" positive shift taking place at top of R5.

Best Bet: Scope will spot this trouble.

Horizontal Bending

SYMPTOM 6

Intermittent Loss of Sync

R6 Increased in Value

(V1B Grid Resistor—120K)

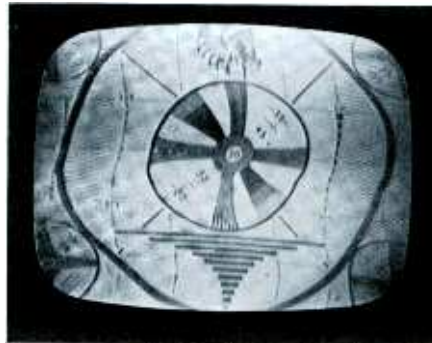

Frequency coil must be set at end of range to lock in picture. Even so, entire picture bends and pulls; sync is intermittent, and 8 to 10 bars are present when it's lost. Adjustment of waveform slug will give fair sync, but bending and pulling still persists.

Waveform Analysis

Viewing W1 with scope preset to 7875 cps shows flutter in sawtooth portion of signal (amplitude is good). Good W1A proves sync input okay. Frequency of oscillator is slightly wrong, affecting sample signal. Improper W3 suggests waveform slug needs adjusting, but attempt to obtain equal peaks throws picture out of sync. Shorting L2-C6 doesn't help; L1A is still at end of range further hinting defective frequency-determining component.

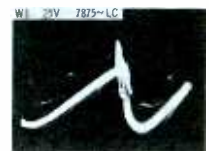

Voltage and Component Analysis

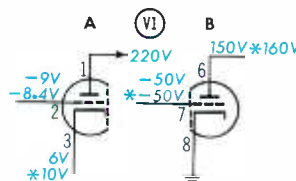

Slight suspicion of trouble in cathode circuit of V1A or grid circuit of V1B is aroused by voltages there, when coupled with conclusion of frequency determining problem in Waveform Analysis. Values of R3, R5, and R6 are critical since they affect AFC and oscillator bias. Small value change in either will affect free-running frequency. Here, R6 has changed to 150K—only 25%, but enough to prevent automatic or manual correction. Close-tolerance (5%) resistors are always suspects when frequency isn't correct.

Best Bet: Scope or VTVM isolates; ohmmeter finds answer.

BEST PROFESSIONAL VTVM VALUE

EICO 232 peak-to-peak VTVM featuring exclusive Uni-probe® (U.S. Pat.)



Deluxe VTVM for color & B & W

- Calibration without removing from cabinet
- Measure directly p-p voltage of complex & sine waves: 0-4, 14, 42, 140, 420, 1400, 4200
- DC/RMS sine volts; 0-1.5, 5, 15, 50, 150, 500, 1500 (up to 30,000 volts with HVP probe, & 250 mc with PRF probe)
- Resistance ranges: 0.2 ohms to 1000 megs in 7 ranges
- 7 non-skip ranges on every function
- 4 functions: + DC Volts, - DC Volts, AC Volts, Ohms.
- Uniform 3 to 1 scale ratio for extreme wide-range accuracy
- Large 4 1/2" meter in can't-burn-out circuit
- Zero center for TV-FM discriminator alignment
- Smart professional styling—new satin finish etched panel with contrasting knobs and meter and grey wrinkle steel case.

Kit \$29.95; wired \$49.95.

Exclusive UNI-PROBE: (pat. pending) Terrific timesaver, performs all functions: A half turn of probe-tip selects DC or AC-Ohms

EICO KITS FOR 1964

BEST BUY SCOPES



EICO 460 WIDEBAND 5" SCOPE For color & black-and-white TV servicing. Easily reproduces 3.58 mc color TV synchronizing burst. Vert. amp. flat from DC to 4.5 mc, usable to 10 mc; 25 mv rms/inch sensitivity. Horiz. amp. flat from 1 cps to 400 kc; 0.6 v rms/inch sensitivity. Automatic sync. Sweeps from below 10 cps to 100 kc. Kit \$89.95; Wired \$129.50.



EICO 427 ADVANCED GENERAL PURPOSE 5" SCOPE High sensitivity scope has all the facilities and quality demanded for servicing audio, communications and industrial equipment. Vert. amp. flat from DC to 500 kc, -6 db at 1 mc; 3.5 mv rms/cm sensitivity. Horiz. amp. flat from 2 cps to 450 kc; 0.18 v rms/cm sensitivity. Automatic sync. Sweeps from 10 cps to 100 kc. Kit \$69.95; Wired \$109.95.



EICO 430 PORTABLE GENERAL PURPOSE 3" SCOPE Remarkably fine compact scope. Excellent for servicing audio, communications, and industrial equipment. Ideal as a ham shack monitor. Flat-face 3" CRT with mu metal shield eliminates affects of external fields. Vert. amp. flat from 2 cps to 500 kc, -6 db at 1 mc; 25 mv rms/cm sensitivity. Horiz. amp. from 2 cps to 350 kc, 0.25 v rms/cm sensitivity. Sweeps from 10 cps to 100 kc. Kit \$69.95; Wired \$99.95.



EICO 955 IN-CIRCUIT BRIDGE-TYPE CAPACITOR TESTER Unique shunt-resistance balancing* provision, permits in-circuit short checks even in the presence of as little as 1 ohm shunt resistance. Sensitive open check down to 15 µmf normally, adjustable to as little as 5 µmf. Wien Bridge capacity measurements from 0.1 to 50 µf. Kit \$19.95; wired \$39.95 *Pat. applied for.



EICO 667 DYNAMIC CONDUCTANCE TUBE & TRANSISTOR TESTER Combines mutual conductance test with a peak emission test—gives a single reading of tube quality. Also spots bad NPN and PNP transistors by gain and leakage tests. New 1964 design has sockets and settings for the latest receiving types, including 5 and 7-pin novistors. Also tests novars, 10-pin miniatures, and compactons, many low-power transmitting and special-purpose tubes, voltage regulators, electron-ray indicators, etc. Multi-circuit lever switch; 13 tube-element pushbutton switches. 4 1/2" meter; roll-chart in snap-in window. Kit \$79.95; wired \$129.95. **EICO CRU CRT ADAPTER**—Adapts 667 to test all color and B & W CRT's. Wired \$9.95.



EICO 369 TV/FM SWEEP GENERATOR WITH BUILT-IN POST INJECTION MARKER FEEDS Only the sweep signal to the circuit under test or alignment. A demodulator picks off the response signal and feeds it to a mixer stage where the markers are added before scope display. Thus, troublesome interaction effects are eliminated. Sweep generator has controllable inductor sweep circuit (all electronic) with no mechanical parts to wear and give trouble, and 5 fundamental ranges from 3.5 to 316 mc. Variable frequency marker provides output on 3 fundamental ranges from 2 to 60 mc., and 60 to 225 mc range on harmonics. 4.5 mc crystal supplied for rapid check of marker generator alignment. Kit \$89.95; wired \$139.95.

FOR COLOR AND B & W



TOP-NOTCH TRANSISTOR TESTING TEAM

EICO 1020 POWER & BIAS SUPPLY with 0.005% ripple. Continuously variable metered output voltage, 0-30 VDC at 150 to 300mA. Kit \$23.95; wired \$29.95.

EICO 680 TRANSISTOR & CIRCUIT TESTER Measures basic characteristics of signal and power transistors. Provides DC current, DC voltage (20K ohm/volt), and resistance ranges normally needed for transistor work. Kit \$25.95; wired \$39.95.

EICO Electronic Instrument Co., Inc. PF-7
131-01 39th Avenue, Flushing, N.Y. 11352

Send new 1964 catalog featuring more than 230 EICO Products.

NAME _____
ADDRESS _____
CITY _____ ZONE _____ STATE _____
Add 5% in West

FM stereo seems here to stay. More and more FM stations are transmitting stereo programs, and a large number of new FM receivers, from large consoles to table radios, are now equipped for multiplex. The alert serviceman should be prepared to align these units in minimum time with maximum accuracy. This article will explain how.

A properly aligned multiplex receiver can deliver the same listening pleasure as a stereo phonograph. However, a misaligned multiplex receiver will do no more for a stereo FM broadcast than will a monophonic receiver. To assure your customer the greatest listening pleasure, be sure his multiplex unit is functioning properly. This can often be done by the simple adjustment of either the sensitivity or separation control. In other cases, more complete realignment may be needed.

Many servicemen shudder at the thought of an alignment job. Do not place yourself in this category. A complete multiplex alignment job is not really difficult, nor is it vastly time consuming. Using the correct procedure, you can completely align any multiplex receiver in a few minutes.

General Considerations

Multiplex receivers differ widely

in circuit design. However, they all must accomplish the same result. The multiplex receiver or adapter must redevelop a 38-kc subcarrier in exact phase with the transmitted 19-kc pilot signal. This 38-kc subcarrier must be combined with the L-R sidebands transmitted as sub-channel modulation by the FM station. The subcarrier sidebands must then be detected, leaving only the L-R signal, which is then mixed with the L + R signal to produce L and R information for the audio amplifier channels. (The L + R signal is the monophonic FM signal.)

To achieve proper separation in any multiplex receiver, the RF and IF sections must be properly aligned. The bandwidth of the IF response curve should be at least 150 kc—preferably 200 kc. Since the L-R sidebands extend to approximately 53 kc, an IF strip with narrow bandwidth would attenuate these signals and cause poor separation.

It is not necessary to check RF and IF alignment first, if you are using a stereo generator that has an RF output. After the multiplex section has been aligned with only the stereo signal, connect the RF output of the generator to the antenna terminals. If the same separation exists as with the direct connection, the RF-IF bandwidth is probably okay.

KEY TO



Most multiplex receivers are equipped with a stereo indicator light, and in many cases a sensitivity control determines when the light operates. The control should be adjusted so the indicator will glow when the receiver is tuned to a station transmitting FM stereo. The light should only flicker when tuning through monophonic FM stations.

Another control on many receivers is the *separation* control (sometimes called *matrix* or *stereo balance*). This control can usually be adjusted properly by listening to the output of the speakers. Adjust the control for minimum sound from the opposite speaker during a single-channel broadcast (stereo test signal). That is, there should be minimum sound from the right speaker for a left-only signal, or vice versa. If this result cannot be achieved, the unit has a faulty component or is in need of shop alignment.

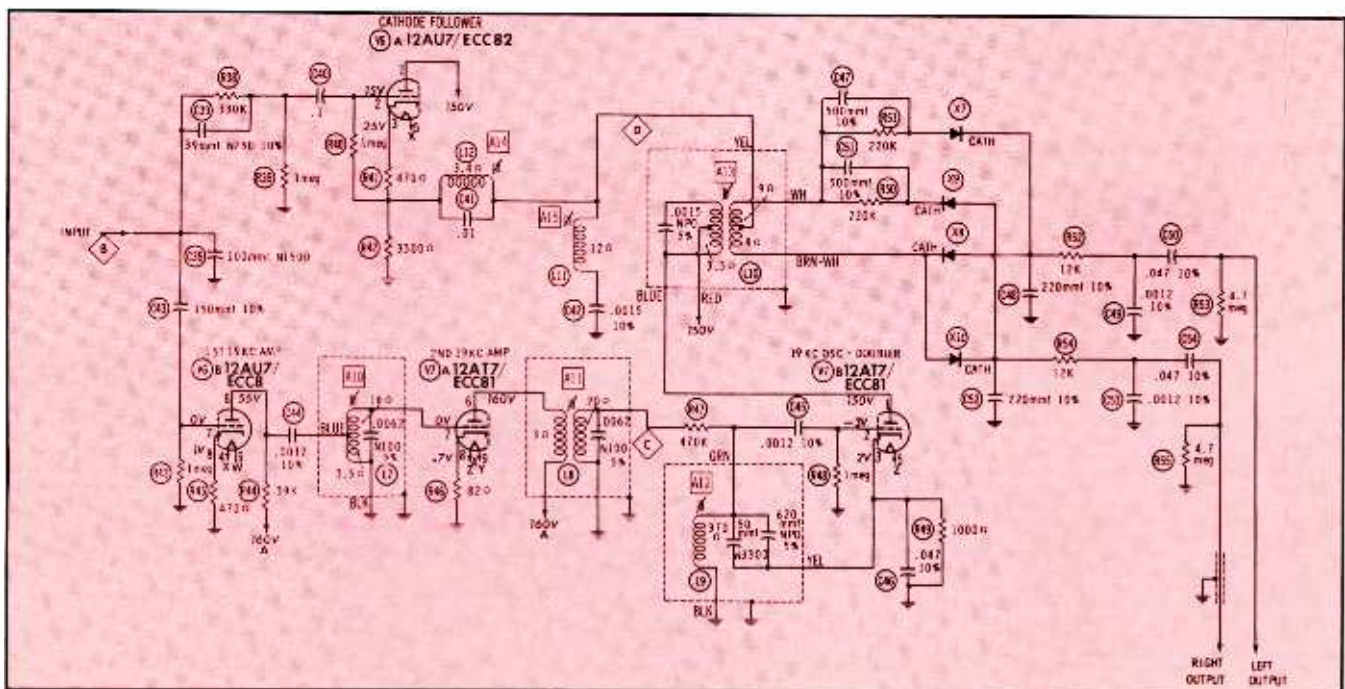

Fig. 1. Adapter portion of stereo FM receiver recovers the individual L and R Signals.

STEREO ALIGNMENT

by Norman D. Tanner

Typical Circuits

In the circuit in Fig. 1, V6B and V7A are both 19-kc amplifiers. Both L7 and L8 are tuned to 19 kc. In the grid circuit of V7B is a 19-kc oscillator coil, L9. This oscillator is free-running in the absence of a signal from V7A but is locked in phase with an incoming 19-kc pilot signal. Doubler coil L10 is tuned to 38 kc. Coil L12 and capacitor C41 serve as a 38-kc bandpass network for the L-R signal, and L11 and C42 form a 67-kc trap.

In the circuit of Fig. 2, only one tube is used. This tube functions both as a 19-kc amplifier and as a 38-kc amplifier through reflex action. The incoming 19-kc pilot signal is coupled to the grid through L22. This signal is amplified and fed to L24, which is tuned to 19 kc. Diodes M12 and M13 act as frequency doublers. The 38-kc output of these diodes is fed back to the grid through L23 and L22. The 38-kc signal is amplified and taken from the plate by L25A, which is tuned to 38 kc and feeds the signal to the detector diodes. The information for both L-R and L+R is taken from the cathode of the tube. The 38-kc bandpass coil (L25B) selects the L-R information and couples it to L25A. The L+R signal is mixed with the L-R signal at the output of the detectors.

Alignment Procedures

The alignment procedures that follow were used on a receiver employing the circuit shown in Fig. 1; all number references are to this figure. The same general procedure, with appropriate modifications, can be used to align any FM stereo unit.

Equipment Requirements

An FM stereo generator and an

oscilloscope are the only essential pieces of equipment required for alignment. However, in the separation test, an additional oscilloscope or an AC VTVM makes it unnecessary to switch the indicator from channel to channel. The oscilloscope must be connected to the circuit through a 47K resistor or a low-capacitance probe. If this is not done, the oscilloscope will detune the coils across which it is connected and cause erroneous readings.

The generator used in the alignment procedure that follows is a type that provides audio signals and a 67-kc subcarrier. If you are using a generator without a built-in 67-kc subcarrier, this signal may be obtained from an external oscillator. However, be sure the oscillator is accurate. The audio signals may also be obtained from an external oscillator; accuracy is not critical for these latter signals.

Pilot-Channel Adjustments

Connect the 19-kc output of the generator to point B, the multiplex input. This point is always between the FM-detector output and the deemphasis network. Connect the vertical input of the oscilloscope to

point C. This point was chosen as the monitoring point because it is the last place at which the 19-kc pilot signal appears in its transmitted form. Adjust A10 and A11 for maximum output. Both of these coils are peaked at 19 kc and have rather high Q. No trouble should be encountered in determining their correct settings. The waveform obtained at this point is W1 in Fig. 3. Notice that the oscilloscope was set to display three cycles of this 19-kc waveform. It is important to set the exact number of cycles at this point because twice this number should be observed in the next step. The 19-kc oscillator coil and the 38-kc doubler coil should be adjusted next. In some receivers the 19-kc oscillator coil is not used; instead the incoming 19-kc pilot signal is doubled to 38 kc. In either case, the oscilloscope connection is the same—point D. The 19-kc pilot frequency should be doubled at this point, showing six cycles on the oscilloscope. The amplitude of this signal is considerably less than that at point C.

Adjustment of A12 is very critical, and unless you are familiar with this circuit difficulty may be encountered in obtaining proper adjustment of the oscillator. There are two different methods of adjustment. The oscillator and doubler coil may be aligned for maximum indication at point D. When doing this, be sure the oscillator is locking with the incoming 19-kc pilot signal. Do not

• Please turn to Page 54

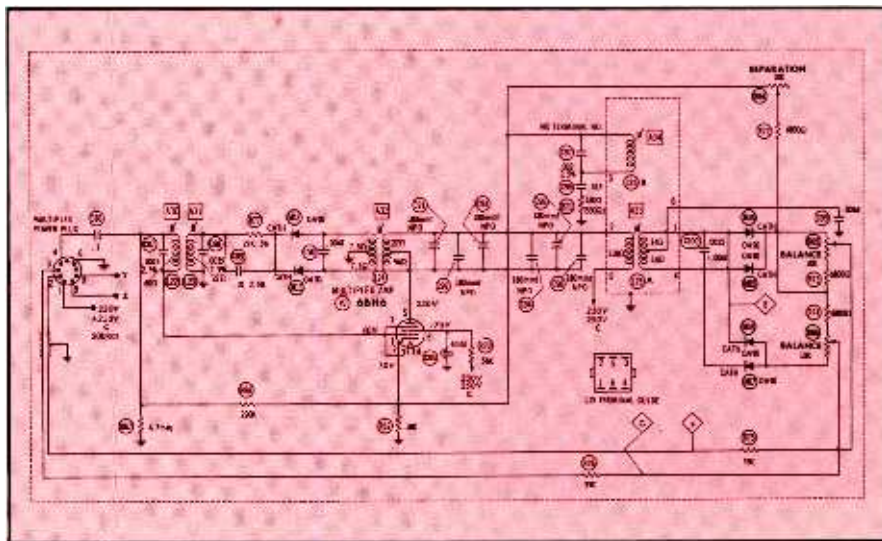

Fig 2. Diagram of reflex-type stereo adapter using single tube.

Any means, method, technique, or device that will cut servicing time, eliminate using certain equipment, and reduce labor is most welcome to servicemen. Real shortcuts are most profitable when they save time, for time is after all as important to the technician as a first-class repair is to the customer.

However, many shortcuts are not universally applicable. Some may save considerable time nine tries out of ten, but on the tenth they may waste more time than was saved on all the others. Other shortcuts can actually cause certain components to be overworked to a point where they break down; still others alter a circuit just enough to prevent normal operation.

Foremost among questionable shortcuts is the temptation to repair or align equipment without proper service instruments, even when such instruments are readily available. While some servicemen continue to work in this manner, believing they are using shortcuts, these "time savers" are actually unsound practices that waste valuable time.

Incorrect Bench Setup

One rather common time- and labor-saving "shortcut" is removing to the shop only those sections of a



(A) Indicates defect

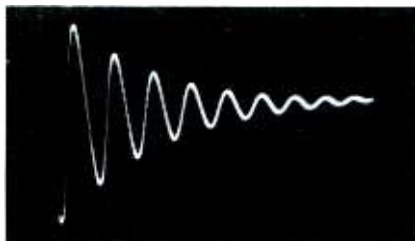

(B) Yoke disconnected

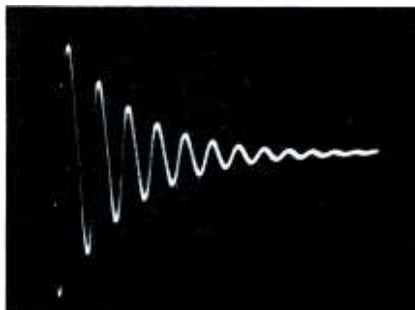

(C) New yoke connected

Fig. 1. Results of horizontal ringing tests.

set that seem to be defective. In many cases this results in leaving the speaker and picture tube in the customer's home. Further, a serviceman may doubt that the deflection yoke is defective, and not bring it in, preferring to use one he has in the shop. An interesting case recently developed from one such circumstance.

When a fellow technician's scope broke down, he asked me if I would look at a set that was giving him trouble. I agreed, and he brought over an RCA KCS83 chassis and yoke. Because only a short, feeble arc could be drawn from the high-voltage lead to ground, and boost was less than normal, he doubted that enough drive was being developed by the horizontal oscillator. Placing the set on its side so I could scope the horizontal-drive waveform, I noted that he had already replaced a number of capacitors in the horizontal circuit. The scope indicated plenty of drive signal, apparently at the correct frequency.

After disconnecting the cheater cord from the set, I made a ringing test of the horizontal inductances. With the scope ground lead to the set chassis and the scope input lead (together with the pulse source from the scope) to the horizontal amplifier plate lead, I obtained the scope trace shown in Fig. 1A, indicating either a bad flyback or yoke. Disconnecting the yoke produced the normal waveform shown in Fig. 1B, indicating the yoke was bad. "But," he demurred, "that's the shop yoke I use on all RCA's." To clinch the matter, a new yoke we had in the shop was plugged in, and the perfectly normal waveform of Fig. 1C resulted. Further, when the set was turned on, a healthy arc was obtained from the high-voltage lead,

and the boost voltage tested okay.

He believed his yoke was good because he had been using it successfully on many older RCA's. I asked if he had been using it with the picture tubes, and he admitted using it only to check high voltage. That answered everything; the sets where he had used this yoke were probably all of the direct-drive type where a faulty yoke will barely affect high voltage. The KCS83 uses an autotransformer flyback with the yoke shunting a portion of the windings; a defective yoke will definitely affect high voltage. This fact was clearly presented along with ringing tests in the *Shop Talk* column of PF REPORTER, March 1963.

This time-wasting "shortcut" resulted from several factors: First, he had replaced the picture tube very recently—no sense bringing that in, he thought. Second, he had never seen a defective yoke affect high voltage so severely and believed that a keystone raster should have been the symptom. Third, he jumped to the wrong conclusion that insufficient horizontal drive was the trouble, and he allowed his first hasty analysis to cloud all his subsequent thinking. Judging from the number of capacitors replaced, he put in plenty of excess time on this

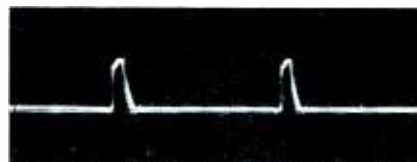

(A) Horizontal, without speaker

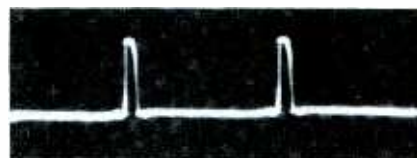

(B) Sync with speaker connected

Fig. 2. Sync pulses with and without speaker.



set, thanks to his so-called “shortcut.” The job would have been more profitable had he brought in the complete set.

Without the Speaker

Leaving the speaker in the cabinet when the chassis is taken to the shop is another time- and labor-saving shortcut that backfires. This shortcut should be subjected to one common-sense rule: leave only speakers that have two (voice coil) wires, and then only when the sound is perfect. Disregarding this rule can waste more time in the shop than it saves in the home. In many receivers, the mid-fifties’ Admiral models for example, the shop man might have to spend as long as 20 minutes checking circuits to hook up jumpers, output transformers, etc., while it would take the house-call serviceman just a few extra minutes to remove and subsequently reinstall the speaker.

Another serviceman friend asked me to stop in to check a set that worked differently in his shop than it did in the customer’s home. It was an RCA KCS47 which had been brought in because the horizontal oscillator was drifting out of sync. The sound was perfect, so the speaker was left with the cabinet. In the shop, my friend had replaced



(A) 60-volt amplitude was clue

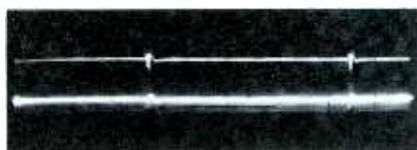

(B) Normal 22 volts after repair

Fig. 3. Excessive sync signal caused flipping.

two capacitors in the horizontal circuit, aligned the phasing coil, and noted that horizontal locking was very good. On returning the set to the customer, he found that lock-in was possible only with the hold control at one end of rotation. Since horizontal-hold trouble was the original complaint, he feared this condition indicated a callback. Once again he brought the set to his shop.

When I got there, he readily demonstrated how strong the hold action was. I saw that he had not connected a speaker and suggested that he do so. Hooking in one jumper and a transformer-coupled speaker, he found the same narrow-hold condition experienced in the home. When he requested an explanation, I suggested he scope the sync output signal under both conditions. With no speaker connected, the waveform shown in Fig. 2A was obtained; with a speaker, the display changed to that of Fig 2B. Since the sync pulse is combined with a sample signal to control the AFC tube in this type of *Synchroguide* circuit, the amplitude of the sync pulse, while not too critical, does affect horizontal hold range.

Another no-speaker “shortcut” created a different problem. This set, a Crosley 426, belonged to the counterman of our distributor. He had recently replaced the picture tube and flyback, only to find the set had developed intermittent vertical roll.

I operated the set at the far end of the bench where I usually cook finished jobs and glanced at it occasionally while working on other sets. Sure enough, it did roll a few frames every couple of minutes; so, when I got the chance, I moved the set up to where my test equipment is. My first check with the scope—at the input of the vertical integrator—presented the trace shown in Fig. 3A, a very good-looking sync signal except that its amplitude was several times larger than normal. This led to DC voltage checks that revealed 225 volts on the 150-volt line. Further checks showed that a shorted capacitor (C1 in Fig. 4) was responsible for the increased sync voltage. Replacing C1 brought the 150-volt line down to normal and restored normal amplitude to the sync, as shown in Fig. 3B. The reason rolling was caused by ex-

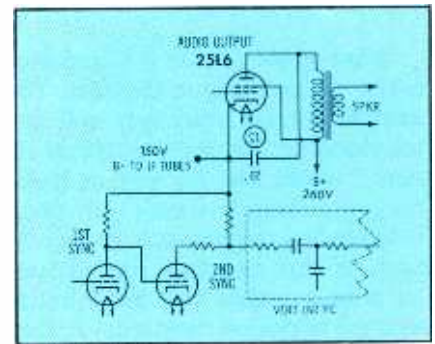

Fig. 4. Very leaky C1 in stacked B+ supply placed high voltages on vertical sync tubes.

cessive sync is better understood if you remember that the time constants of the integrator circuit depend on the amplitude of the vertical pulses to form a proper triggering pulse.

The “shortcut” of not connecting a speaker to this set prevented my noticing the absence of audio, a symptom that should have easily led to the discovery of the shorted capacitor. Whenever troubleshooting is done without the speaker, the audio must be checked before the set is returned to the customer.

Checking without the speaker can have other disagreeable results. In some receivers, the capacitor at the plate of the audio output tube will break down unless the volume control is kept at minimum. In sets using inverse feedback, as in the GE M5 line (Fig. 5) and others, a peculiar type of low-frequency oscillation occurs when the output is not loaded by a voice coil.

Wrong Way to Service Auto Radios

Because no additional equipment is required, shops that repair TV receivers generally welcome home-radio repairing. For servicing auto radios, however, a DC power supply should be used. In spite of this, some servicemen believe they can do a good job using 6 or 12 volts AC from a transformer. Dead or weak sets can be serviced with an AC supply, especially those in vi-

• Please turn to Page 57

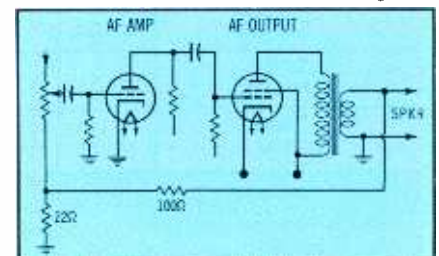

Fig. 5. Sets with inverse feedback might have subsonic oscillation without speaker.

What would you do if a customer asked, "I am going to Germany (or another foreign country); will my television set operate over there? If not, I would like for you to make the necessary revisions, providing it is not too expensive." A request such as this can find you without an answer unless you are familiar with the television standards of other countries.

Tables 1 and 2 show the five basic transmitting systems and in which countries they are used. Table 3 lists the transmitting frequencies for various countries. From this data you will be able to determine if conversion is necessary and what circuits will have to be altered. Each system will be dealt with individually as pertaining to conversions to or from U.S. standards.

Is Conversion Possible?

The 819-line, 405-line, and 625-line (OIRT) systems vary greatly from ones used in this country. Therefore, a receiver designed for operation in any country using one of these systems cannot be converted for operation in this country without exceeding reasonable cost to the customer. To accomplish such a modification of these systems would require a new tuner along with complete overhaul of video and sound circuits. In either the 405-line or 819-line sets the horizontal circuit would need complete redesign.

Converting a 525-line receiver for operation on the 625-line system (CCIR), or vice versa, is possible; however, this can become quite

complicated—as will be discussed later.

525 Line

All countries using 525-line transmission, with the exception of Japan, have the same set of channel frequencies and employ specifications identical to those of the United States. Therefore, receivers

will be necessary to either install new channel strips (in turret tuners) or make additional modifications to the tuned circuits. In some instances it is advisable to install a new tuner. Similar adjustments will be required when preparing an American-made set for use in Japan.

625 Line (CCIR)

As shown in Table 1, specifications for the 625-line CCIR system are not drastically different from 525-line specs. However, more than tuner modification will be required for conversion; following are the basic circuit changes which may be necessary to convert one of these sets for U.S. operation.

TUNER—Here again the channel frequencies are different from those used in the United States; therefore, the tuner must be modified or replaced. Many European receivers use a 25-mc video IF frequency. This means a replacement tuner would have to supply a 25-mc IF output. Conversions for a tuner with 40-mc output would require about the same alterations as the Japanese system.

VIDEO—The sound-IF frequency used in CCIR countries is 5.5 mc; this can be matched by retuning the sound and adjacent-channel traps, as well as the sound trap in the video output circuit. These adjustments will involve only about a 1 mc change, so component replacement should not be necessary.

SOUND—To match the 5.5-mc sound carrier, sound-IF and detector transformers will have to be retuned. Since component tolerances may not permit the full adjustment, the values of the mica capacitors across the winding may have to be increased (when changing to 4.5 mc) or decreased (if going to 5.5 mc); the required change, however, is seldom more than 30%. Otherwise, changing to or from a 5.5-mc sound IF can be accomplished without further modification.

HORIZONTAL—Since a change of only 125 cps is required in the horizontal frequency, oscillator coil range will normally allow readjustment for proper synchronization. In some instances it may be necessary to slightly increase (for foreign operation) or decrease (for Ameri-



from these countries will operate in the U.S. without modification. To convert a Japanese receiver for reception of American frequencies will, at minimum, require readjustment of the tuner oscillator slugs. If these have insufficient range, it

Table 1

Lines per field	‡405	525	625 (CCIR)	625 (OIRT)	819
Channel Width	5 mc	6 mc	7 mc	8 mc	14 mc
Video Bandwidth	3 mc	4 mc	5 mc	6 mc	10.4 mc
Horizontal Freq (cps)	10,125	15,750	15,625	15,625	20,475
Vertical Freq (cps)	50	60	50	50	50
*Sound Carrier	-3.5 mc	+4.5 mc	+5.5 mc	+6.5 mc	†+11.15 mc

*In relation to picture carrier in transmitter.

†French standards invert video and audio for certain channels.

‡UHF broadcasts in the United Kingdom use CCIR standards.

CCIR — International Radio Consultative Committee.

OIRT — International Radio and Television Organization.

can reception) the capacitor across the horizontal oscillator coil.

VERTICAL—Changing from 60 cps to 50 cps, or vice versa, may necessitate component-value changes in this circuit. This frequency difference represents a change of approximately 20% in power-line frequency, which pushes the tolerance of controls and other components in RC time-constant networks near or beyond their limits. Proper vertical height and linearity may be obtained in many cases within the range of the controls, but remember to make sure the vertical hold control will cause rolling in *both* directions. If difficulties are encountered, a slight increase or decrease of component values should provide correct vertical deflection. Sweep-circuit components such as the vertical-output transformer and deflection yoke should not cause concern.

POWER SUPPLY—Changing from a 50-cps to a 60-cps line, or vice versa, will normally cause no power supply problems unless motor speed is important, as in the case of phonographs or tape recorders. Input and B+ filter networks are usually adequate in their present design. However, unless the 60-cps power transformer is of “healthy” design, overheating may cause early failure when it’s operated at 50 cps.

Differences in line voltage will cause the most difficulty. Many European sets have tapped power transformers which can be easily adjusted to local line voltages. However, transformerless sets designed for 230-volt DC operation will require power-supply modification when brought to this country. The half-wave rectifier circuit will have to be changed to a voltage doubler to supply approximately 230 volts B+. The 230-volt, 300-ma filament supply must be rewired to 117 volts. This can be done by changing to a series-parallel arrangement.

When taking an American set abroad it must be adapted for 230 volts AC. An external voltage divider or, if available, a 2:1 stepdown power transformer may be used for this purpose.

Conclusion

The circuit modifications given here for converting receivers for operation with different standards were of a general nature. A receiver con-

Table 2

405 Line	525 Line		625 Line (CCIR)			625 Line (OIRT)	819 Line
Hong Kong (closed circuit)	Bermuda	Japan	Aden	Italy	Singapore	Albania	Algeria
	Brazil	Korea	Argentina	Ivory Coast	Spain	Bulgaria	Belgium
Ireland	Canada	Mexico	Australia	Kenya	Sweden	China	France
United Kingdom	Chile	Nicaragua	Austria	Kuwait	Switzerland	Czechoslovakia	Luxembourg
	Colombia	Okinawa	Belgium	Lebanon	Syria	Hungary	Monaco
	Costa Rica	Panama	Congo	Malaysia	Turkey	Poland	Tunisia
	Cuba	Peru	Cyprus	Malta	Uganda	Romania	
	Dominican Republic	Philippines	Denmark	Morocco	United Kingdom (UHF)	USSR	
	Ecuador	Saudi Arabia	Finland	Netherlands	Upper Volta		
	El Salvador	Taiwan	Gabon	New Zealand	Venezuela		
	Guatemala	Thailand	Germany	Nigeria	Yugoslavia		
	Haiti	Trinidad	Gibraltar	Norway			
	Honduras	United States	India	Portugal			
	Iran	Uruguay	Indonesia	Rhodesia			
	Jamaica		Iraq	Sierra Leone			
			Israel				

version can be quite involved for the serviceman and rather expensive to the customer. A close analysis of what has to be done and difficulties

which may arise should always be performed before an estimate of cost is quoted, the job is accepted, or the procedure is begun. ▲

Table 3

Transmitting Frequencies for Various Countries			
Europe and CCIR Members		Japan	
Video	Sound	Video	Sound
48.25 mc	53.75 mc	91.25 mc	95.75 mc
to	to	to	to
224.25 mc	229.75 mc	211.25 mc	215.75 mc
France and Monaco		Russia and OIRT Members	
Video	Sound	Video	Sound
52.40 mc	41.25 mc	49.75 mc	56.25 mc
to	to	to	to
212.85 mc	201.70 mc	223.25 mc	229.75 mc
*Ireland		United Kingdom	
Video	Sound	Video	Sound
42.50 mc	48.50 mc	45.00 mc	41.50 mc
to	to	to	to
215.25 mc	221.25 mc	219.75 mc	216.25 mc
Italy		United States	
Video	Sound	Video	Sound
53.75 mc	59.25 mc	55.25 mc	59.75 mc
to	to	to	to
210.25 mc	215.75 mc	885.25 mc	889.75 mc

*Ireland uses both CCIR and United Kingdom transmissions.



QUICKER SERVICING

aerosols

spray cans are
the rule now . . . not
the exception

In Servicing Chemicals

This is the age of the aerosol—an era in which the spray method of contact cleaning, component lubrication, and similar applications has proved to be a major aid to today's technician. The engineer, TV service technician, and hobbyist have become as dependent upon spray products as has the American housewife.

The photos in Fig. 1 illustrate a few common applications of aerosols. Manufacturers of cleaners and lubricants for the service trade have developed more efficient, safer, and easier-to-use chemical products, often paralleling advances in equipment development.

Many useful chemicals are supplied in 6-ounce cans for convenience on the bench, in the home, or in the service caddy. Many have a flexible plastic tube 6" to 10" long that permits access to hard-to-get-to spots in TV's, small radios, etc., often without dismantling the chassis.

Let's investigate aerosols and see what chemicals are available and how they can serve you more efficiently.

Cleaner-Lubricant Sprays

Numerous manufacturers have products designated as tuner cleaners, control cleaners, contact cleaners, etc. Although similar in formulation, many sprays have special characteristics. Some have a light oil base combined with a strong solvent that is most effective for lubricating and renewing contact efficiency on heavy-duty equipment switches, relays, and volume and tone controls. Others contain silicone compounds and are formulated to lubricate electrical contacts and controls on radio and television equipment. These are highly effective for use on TV tuner assemblies. The silicone compounds assure effective heat-resistant lubrication and extended protection to small electri-

cal contacts and heavy-duty controls alike.

Most service chemicals are non-flammable and, unlike carbon tetrachloride, leave no deposit. When choosing a compound for application to high-frequency circuit components, be sure to select one that will not alter the response of the circuit. A few trade names in this category include: *Tun-O-Lube*, *Trol Aid*, *Contact Kleen*, *EC-44*, *Tuner-Cleaner*, *Merit-Lube*, *Kleen-Tune*, *Ox-Nox*, *Jif*, *De-Ox-Id*, *Spra-Kleen*, and *Wissh*.



Antistatic Sprays

Antistatic compounds are used primarily for cleaning safety glasses, picture tubes, and cabinets. Several manufacturers offer a similar cleaner for use on phonograph records; others provide a single compound for both purposes. These fluids dry rapidly and leave a protective film that reduces the attraction of dirt and dust. Available brand names include: *Mark-N-Glas*, *Mask-Glas*, *Glass-Mate*, *Kleen-Vue*, and *Lens-Kleen*. Among household products, *Windex* has proven useful for cleaning safety glass, and offers little attraction for dust.

Insulating Compounds

Insulating sprays act as an electrical insulator. They are recom-

mended for use in television high-voltage circuits to control corona discharge and arcing. Acting as a coating for coils and transformers, sealing electronic components from humidity and moisture, these products have a very high dielectric strength—to name a few: *Koloid*, *K-29*, *No Arc*, *Hi-Volt*, and *Insul-Volt*.

Component Coolant Sprays

Chemicals of this type aid in locating heat-caused intermittents in electronic equipment through local cooling of capacitors and other components while the set is in operation. This method can save countless hours needlessly wasted through trial and error. Heat-sensitive transistors and phono cartridges can be cooled prior to soldering. Coolants are also useful in obtaining inactive resistance readings of thermistors. These sprays are available under such names as *Frost Aid*, *Chill-It*, *Merit-Kool*, *Freeze-Mist*, and *Zero-Mist*.

Lubricating Solvents

These sprays may be applied in TV sets at the junction of the yoke and picture tube for loosening frozen yokes without damage to the CRT or yoke windings. Another use is in record-changer and tape-recorder mechanisms to prevent rust and corrosion and to remove corroded control nuts and screws. *Pen-A-Lube*, *Chem-Oil*, and *E-Z-Off* are a few familiar brand names.

Miscellaneous Products

The remaining frequently used aerosols include varnishes and enamels in many colors for use on porcelain, plastic, metal, and wood. They dry in minutes, are lead-free, and contain no propane or butane. Various transparent and stain sprays are also available. Grease, cement, or ink can be washed from the



How to calculate required resistance in silicon-for-selenium rectifier replacement

■ Will silicon rectifiers used as replacements for selenium rectifiers fail in predominantly capacitive circuits? Not if you pay strict attention to the peak current limits of the replacement units, as specified by the manufacturer.

Why may silicon replacements fail?

Failure is caused by excessive inrush currents during the first few cycles after turn-on. Silicon rectifiers have extremely low impedance in the conduction region at voltages above 1.5 volts. In addition, the capacitor "looks" like a short circuit until it is charged. This combination allows extremely high currents to flow from low impedance sources such as household mains. Being small, the rectifier has so little thermal mass that failure is instantaneous.

Watch your resistance

Sarkes Tarzian F Series rectifiers are widely used in replacement applications. They carry a surge current rating of 30 amperes. With a 120 volt line, the maximum instantaneous voltage that can be impressed is 1.4 times 120, or 168 volts. You should add to the circuit a minimum surge limiting resistance of $\frac{168}{30}$, or 5.6 ohms. This will apply to doubler or half wave circuits.

For practical purposes, we can ignore the impedance of an F unit with 168 volts impressed during the conduction cycle.

Transformer sets require no additional resistance. Enough impedance is inherent in the secondary to provide limiting action. Figures 1, 2, and 3 show typical circuits and recommendations. Our best advice to you: depend on Tarzian silicon rectifiers for dependable performance.

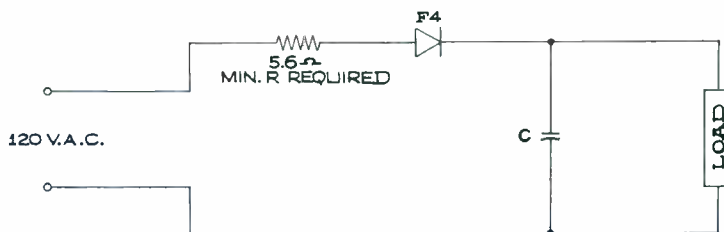

Fig. 1 Rectifier replacement—no transformer

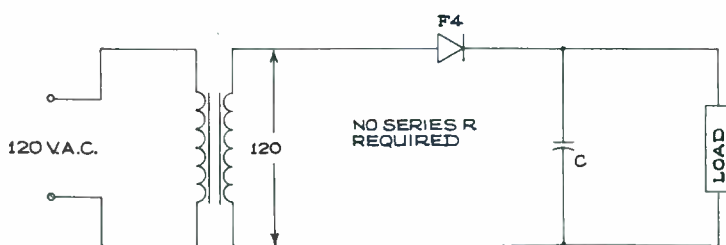

Fig. 2 Rectifier replacement—with transformer

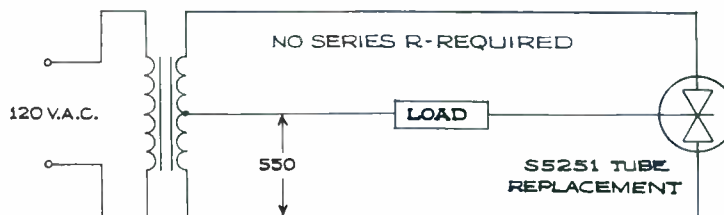

Fig. 3 Tube replacement



The Tarzian Replacement Line includes silicon rectifiers and conversion kits, tube replacement silicon rectifiers, and "condensed stack" selenium rectifiers. Immediately available from distributors throughout the nation, in the quantities and ratings you want most.

FREE... The new 48-page Tarzian Silicon Rectifier Handbook is crammed with interesting technical information and product specifications. For your free copy, ask for Handbook 63-SI-6.



SARKES TARZIAN Inc.

World's Leading Manufacturers of TV and FM Tuners • Closed Circuit TV Systems • Broadcast Equipment • Air Trimmers • FM Radios • Magnetic Recording Tape • Semiconductor Devices

SEMICONDUCTOR DIVISION • BLOOMINGTON, INDIANA

Canadian Licensee: Marsland Engineering Limited • 350 Weber Street North, Waterloo, Ontario

Circle 14 on literature card

CONTACT CLEANER



AND LUBRICANT

NEW FASTER ACTING FORMULA! NON-FLAMMABLE

Spra-Kleen! The easy way to remove noise caused by dust, dirt and corrosion. Cleans electrical contacts like new! Controls, relays, switches are cleaned and lubricated quickly, easily, in one simple operation. Spra-Kleen may be applied effectively up-side-down or right-side-up without removing the chassis. Merely apply, work the controls, Spra-Kleen does the rest. A must for every serviceman!

Part No.	Net
8666-16 16 oz. spray can	1.95
8666 6 oz. spray can	.99
8666-3 3 oz. pocketsize spray can	.78



NEW CATALOG
JUST OFF THE PRESS
GC CATALOG FR-65
WRITE TODAY!



GC ELECTRONICS CO.
400 So. Wyman St., Rockford, Ill., U.S.A.

Circle 15 on literature card

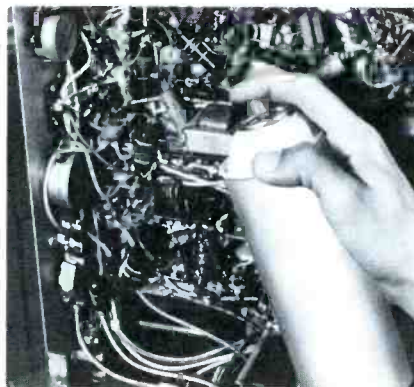

(A) Controls

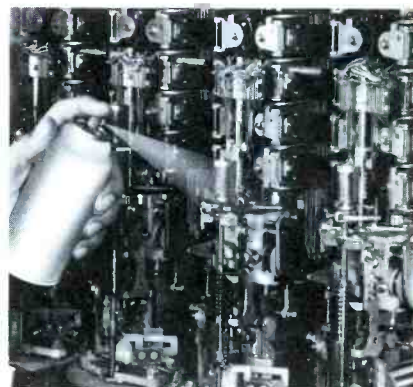

(B) Relays

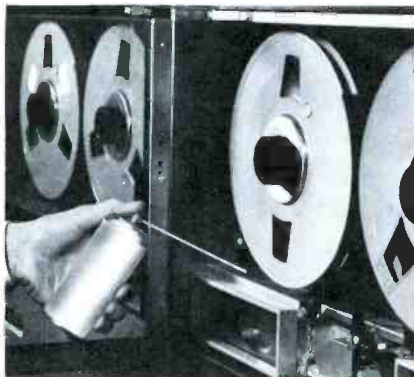

(C) Tape guides

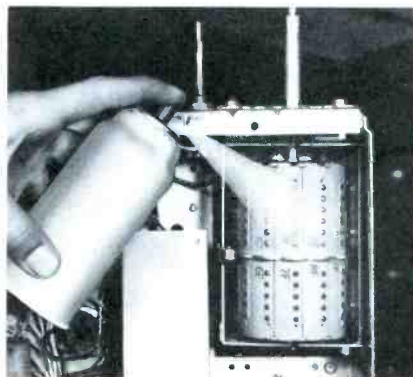

(D) Tuners

Fig. 1. Pressure sprays are used for cleaning and lubricating various electronic equipment.

hands with an aerosol hand cleaner. These cleaners normally contain lanolin and germ-killing solutions, with no harsh, irritating chemicals.

Choose Carefully

Today's technician may choose from literally hundreds of service sprays stocked by his local electronic parts distributors. Remember: Poor quality products can take a heavy profit toll through repeated service callbacks. Careful evaluation of a new spray should be made before it is used on expensive electronic equipment.

CAUTION!

Spray cans contain a liquid gas that can be *very dangerous* if the

container is exposed to extreme heat or is punctured. Many users have been badly, even fatally, injured by the explosion of such cans. The can of contact cleaner or other aerosol now on your service bench, *empty* or *otherwise*, should never be exposed to heat. Even after the chemical has been exhausted, the propellant is still active, and sufficient increase in temperature will explode the can.

Before disposing of an empty spray can, it's wise to eliminate the pressure inside; *it's a necessity* if you burn your trash. Reduce the pressure by wrapping the can substantially with heavy rags and storing in a cold place for several hours (overnight in the refrigerator

TV TUNERS* REBUILT OR EXCHANGED

ALL TYPES

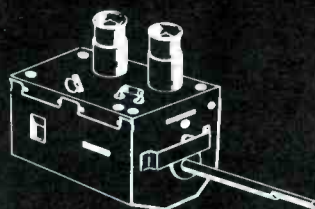

\$9.95 Including all parts and labor
(except broken wafers—billed at cost)

- Normally shipped same day received
- 90 day full guarantee
- U/V combinations \$17.95

FREE—If Mailing carton sent to you on request

Phone REpublic 3-9189

L. A. TUNER EXCHANGE

4611 West Jefferson Blvd.
Los Angeles 16, California

Circle 16 on literature card

Qualify for the most profitable service business of all...



**FM
STEREO
SERVICE**

**with the all new Sencore
MX129 FM STEREO MULTIPLEX
GENERATOR AND ANALYZER**

\$169.50

19 TRANSISTORS
ALL CRYSTAL CONTROLLED
TRULY PORTABLE ONLY 7-1/2 LBS.

It has been established by all Radio and TV manufacturers that you must have a generator of this type to service FM stereo receivers. Here is a new field just waiting for qualified men, a field that is growing as fast as color TV. Multiplex is simple to service with this generator. If you can service an FM receiver, you can service multiplex once you have the MX129.

Look at the outstanding features of this all transistorized Sencore unit and you will see why it is the most versatile, most portable, most trouble free unit on the market. It is just like having your own FM stereo transmitter on your bench or service truck. All signals are crystal controlled and instantaneous because there are no tubes to warm up. Powered by 115 volts AC to insure top performance at all times.

The MX129 produces all signals required for trouble shooting and aligning the stereo portion of the FM multiplex receiver and can be used as a stereo demonstrator by feeding in left and right audio signals into the jacks marked LEFT and RIGHT EXT. SIG. This unique feature will allow you to demonstrate stereo to the customer even when a stereo program is not being broadcast.

The MX129 becomes a complete trouble shooting analyzer with the addition of a meter calibrated in peak to peak volts and Decibels. No other equipment is required for checking channel separation or alignment. A jack marked EXT. METER is provided for connecting the meter to the stereo speakers or at other points after detection.

Here are the signals available on the MX129 for alignment, trouble shooting and analyzing:

- FM-RF carrier with composite multiplex audio signal just like that transmitted from the FM station: 38kc suppressed carrier, 19kc pilot and 67kc SCA signal. This signal available at RF output cable.
- Multiplex signal is formed by either 60 cycle or 1000 cycle internal tones for greater flexibility in testing.
- Full control over left and right channel amplitude (and therefore modulation). Built-in meter is used to set controls for equal modulation of FM carrier. Channels can be turned completely off when desired.
- 19kc pilot calibrated directly in percentage of modulation; can be generated separately for 19kc amplifier peaking by turning down left and right channels.
- External 67kc SCA (subscription) signal available at jack marked SCA OUT (67KC) for trap adjustment. This signal, not found on some high priced multiplex generators, is very important on new stereo receivers with adjustable 67kc traps.
- Composite signals, same as described above, available on jacks marked COMP. OUT for signal injection beyond the FM detector.

SENCORE

Quality at its finest
426 SO. WESTGATE • ADDISON, ILL.

NOBODY CAN CHANGE THE WEATHER BUT OXFORD HAS CHANGED THE PUBLIC ADDRESS SPEAKER MARKET . . . with the introduction of the All New "Outdoor Specialist Series"

Oxford OP-8 and OP-6 Models represent the first major change in weather-proof paging and talk-back speakers in more than ten years. Not just a rehash of other speakers now on the market, but entirely new units incorporating new features, new materials and new design concepts throughout.

NEW BELL DESIGN: Not a compromise, but a true "exponential flair" for maximum efficiency. Molded from *Implex*, a space age material that is practically indestructible and impervious to weather extremes. The 1/4-inch bell sections guarantee vibrationless, resonance-free reproduction.

NEW COUPLING DESIGN: Integral close coupled inner horn and diaphragm allows maximum energy transfer with minimum distortion. Heavy-duty slug magnets are used, not "gimmicked" or less efficient ring magnets.

NEW TRANSFORMER OPTION: The OP-8 and OP-6 are available from stock with 25 or 70 volt transformers built in, or without any transformer. For those who wish to install their own transformers, a standard mounting bracket is provided.



NEW LEVER-LOCK* MOUNTING BRACKET: An Oxford exclusive that swivels 360° in the horizontal plane and 180° in the vertical with a flip of a single lever. The horn may be adjusted to any position without tools or disassembling . . . no thumbscrews to drop either! Stays locked until you unlock it.

Oxford's OP Series is the first in a program that will bring many startling new speakers for public address applications . . . speakers that will meet and exceed the requirements of the dynamic sound industry.

*patent pending

For Complete Information and Specifications,
Write for Product Information Bulletin No. C-103

**OXFORD
TRANSDUCER
CORPORATION**

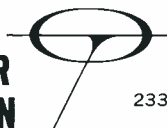

A Subsidiary of Oxford Electric Corporation

2331 North Washtenaw Avenue • Chicago 47, Illinois

Circle 18 on literature card

is suitable). With the pressure reduced, make an opening in the wrapping to expose the bottom of the can. Puncture it with a can opener while the end is pointed away from you. Once the pressure is released, the can is safe—and so are you.

Conclusion

Chemical cleaners, conditioners, and lubricants are here to stay. Research and development continue to produce finer products in this area to fulfill the needs and demands of today's service technician. Modern aerosol spray chemicals can mean better service to the consumer through better service procedures, if they are properly handled.



Magnoval Adapter

Horizontal-output tubes 6GB5, 13GB5, 18GB5, 27GB5, and 28GB5 may now be tested on any tube tester with the use of this special socket adapter. The adapter has an 8-pin octal base on one end (fits into the octal socket on the tester) and a 9-pin magnoval socket to accept the above tubes. The tester controls are then set to check the 'CD6 family of output tubes—6CD6, 25CD6, etc.

The magnoval base resembles that of the *novar*, but the diameters of the individual pins are different. Magnoval base pins are .050"; those of *novars* are .040". The internal connections of the 'GB5 tubes are also different from the *novar* type, preventing use of the *novar* socket for testing (even if the tester is so equipped).

The adapter is manufactured by Seco and sells for \$1.95. Incidentally, they are available free to technicians who purchased tube tester Models 88 or 107A after March 13, 1962. Merely send the serial number of your tester along with your request to the company. ▲

For further information, circle 58 on literature card

helps you make more money
than any other test instrument

Checks CRT emission, interelement shorts and grid cutoff in a jiffy.

NEW

IMPROVED

CRT

CHECKER

and rejuvenator

Only tester that checks all black and white and color tubes without adaptors.

Uses DC on all tests as recommended by tube manufacturers. Exclusive automatic controlled rejuvenation (ACR) insures just the right amount of rejuvenation for each job. You just push the button: The ACR circuit takes over and applies rejuvenation voltage for just the right amount of time.

All hand-wired — all American made.

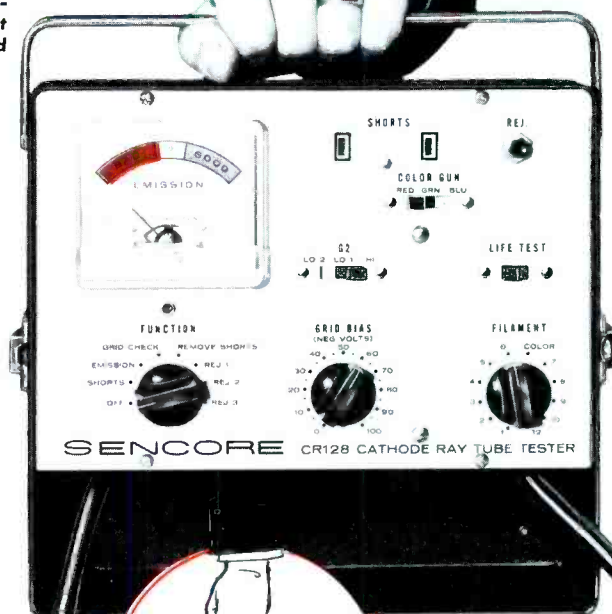

COLOR CABLE

B&W CABLE

Weights only 10 lbs. — Unbreakable all steel case for home or shop.

SENCORE CR128

\$69⁹⁵

Here is a new CRT checker and rejuvenator with the latest in design but at a price far below testers that check round color tubes only. The CR128 checks them all; conventional black and white tubes, new low drive B&W tubes, round color tubes and the recently announced rectangular color tubes.

Tests made are standard in the industry, using DC for all checks to prevent damage and erroneous readings. Color guns are tested individually as recommended by CRT manufacturers. Procedures for color gun tracking tests are explained on back cover of instruction manual.

Exclusive automatic controlled rejuvenation applies rejuvenation voltage for a longer period of time to guns that are lowest in emission. Merely push the rejuvenation button and the RC timer takes over to automatically rejuvenate cathodes, clear shorts or weld open cathodes. A must for equalization of beam currents in poor tracking color tubes. Once RC timer discharges, new rejuvenation voltage cannot be re-applied until button is released and depressed again. It really works; you merely push the button and the automatic circuit takes over.

New all steel portable carrying case protects meter and panel when carried in a service truck. Removable cover can be used as a handy parts tray in the home and fitted to the back while in the shop.

Let your SENCORE Distributor show you how the CR128 will pay for itself the very first month in picture tube sales.

SENCORE

426 SOUTH WESTGATE DRIVE
ADDISON, ILLINOIS

the high cost of **EMPLOYEE THEFT**

Last year employee theft cost American businessmen nearly one billion dollars, and a significant part of that amount came from the electronic service industry.

The words "embezzlement" and "pilferage" give shop owners a decidedly uncomfortable feeling because both crimes are difficult to prevent or detect. Unlike more forthright thieves, dishonest employees needn't carry guns, jimmy windows, or blow safes. They often have the safe combination, a key to the office, and regular access to records, cash, and property. Some also have the opportunity to falsify records to conceal their thefts from trusting employers for years.

Prison inmate 85667, for example, was a trusted employee in a Flint, Michigan shop for seven years. For the next two to ten years he will be working in the State Prison radio shop. He came under routine investigation when his employer discovered a \$450 deficit in the books. Further investigation revealed that 85667 had embezzled more than \$12,000 over a three-year period.

Prisoner 91618 (the numbers have been changed to protect the . . . ?) is another example. He was an itinerant salesman who always had excellent references and who changed jobs almost as often as other people change shirts. He had a wonderful talent for talking gullible customers out of "advance down payments" on special bargains. His usual approach was to offer an irresistible deal on a brand-new television set. Naturally, he didn't acquire much seniority on any job, but he always left with a sizeable



by Dale Morey

bankroll and a supply of letterhead stationery for future reference letters.

Surprisingly, prison is a new experience for 91618 even though many of his employers discovered what he was doing. Why didn't they have him arrested? As he put it himself, "They didn't want any publicity that might make the business look like a swindle. A couple of times I had to make restitution, but they always let me go. At one place they even gave me severance pay."

Giving severance pay to an employee caught with his hand in the till may seem a bit unusual, but it amounts to nothing compared to the price the employers pay for their lack of awareness. Many shop owners unconsciously associate embezzlement with pony-playing bank cashiers who run off to Brazil with a satchel full of cash. The dishonest employee is seldom this conspicuous, but his cost to a business can be enormous if the owner is unwary.

Perhaps a more subtle thief than the embezzler is the anonymous employee who methodically raids stockrooms and parts departments. He is often the same man who steals expensive tools and sells stolen accessories to a dealer's own customers. In some cases, thefts of this type can be more serious than embezzlement; they are more common and often involve more employees. And it is harder to keep an accurate stockroom inventory than to check the cash drawer.

One man, now serving a prison sentence, was formerly employed as chief repairman by a large dealership in Detroit. He had not only complete control of the vouchers that were issued for all parts used in the shop, but also complete charge of the stockroom and sole responsibility for the ordering and inventory of factory parts. This was a perfect setup for any employee with a touch of larceny, and our man wasn't the least bit hesitant about taking advantage of it. Over a three-year period he stole \$25,000 worth of merchandise ranging from capacitors to television sets. This sounds like inventory theft of a high order, but with control over ordering, distribution, and inventory, this thief could have stripped his employers down to their last picture tube.

Failure to guard against employee depredations can be costly since only 10 to 15% of all such losses are covered by insurance. However, there are a number of safeguards that offer insurance where it really counts—before the loss occurs.

The first control that any employer has over his employees is in hiring. All job applicants should be asked to furnish references, and in each case these should be checked out carefully. In too many instances, easily falsified records of previous employment and letters of recommendation are accepted at face value. *Know* the backgrounds of



Some employers are so eager to avoid unfavorable publicity that they even give severance pay to employees fired for stealing from them.

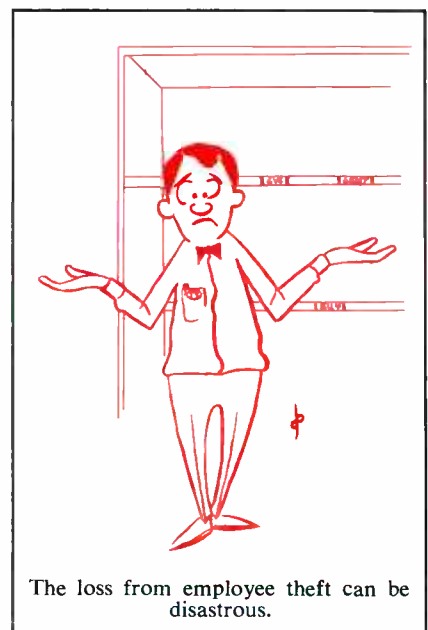

The loss from employee theft can be disastrous.

NEW

IMPROVED

**MIGHTY
MITE!**

NEW

Lower voltage checks for Nuvistors and all new frame grid tubes, as demanded by tube manufacturers, but not found on other tube checkers.

NEW

Speedy indexed set-up cards to reduce "look-up" time. No more cumbersome booklets, or incomplete charts.

NEW

Simplified panel layout reduces set-up time — prevents set-up errors.

NEW

Streamline styling with rounded corners and rubber feet, prevents marring Furniture — presents that "Professional look".

fast, accurate, never lets you down . . .

**New Burn-out,
stick proof meter!**



only

NEW TC 130

\$74.50

Checks them all . . .

including Novars, Compactrons,
Nuvistors, 10 pin tubes — plus
Picture Tubes!

Only 7 Lbs. . .

Smaller Than A Portable Typewriter

Here's the famous MIGHTY MITE, America's fastest selling tube checker, with an all-new look and many new exclusive features. MIGHTY MITE III brings you even greater portability, versatility and operating simplicity beyond comparison. Controls are set as fast and simply as A-B-C right from the speedy set-up cards in the cover. The new functional cover can be quickly removed and placed in a spot with more light for faster reading of the set-up data or "cradled" in the specially designed handle as a space saver as shown above. New unique design also prevents cover from shutting on fingers or cutting of line cords as in older models.

In a nut shell . . . the MIGHTY MITE III is so very popular because it checks for control grid contamination and gas just like the earlier "eye tube" gas checkers (100 megohm sensitivity) and then with a flick of a switch, checks the tube for inter-element shorts and cathode emission at full operating levels. Sencore calls this "the stethoscope approach" . . . as each element is checked individually to be sure that the tube is operating like new. User after user has helped coin the phrase "this checker won't lie to me". Most claim that it will outperform large mutual conductance testers costing hundreds of dollars more and is a real winner in finding those "tough dogs" in critical circuits such as color TV and FM stereo.

**See Your Parts Distributor-- And See
The Mighty Mite III For Yourself!**

SENCORE

426 SOUTH WESTGATE DRIVE
ADDISON, ILLINOIS

Circle 20 on literature card

July, 1964/PF REPORTER 43

"Costs a bit more than 1 transistor VHF amplifiers."



"It should—it has two transistors."

"Fine, but is it worth the difference?"

"You bet, when you measure the couple extra dollars against the many hours of superb TV reception you will enjoy."

"Tell me more."

"The new Blonder-Tongue Vamp-2 outperforms all home VHF amplifiers on the market, tube or transistor. Brings in sharp, clear pictures."

"But, what's the real advantage of two transistors?"

"More signal power, lower noise for snow-free reception."

"But, I hear transistor units can overload from strong local TV stations?"

"Not this one, that's where the extra transistor pays off."

"I've got two sets."

"The Vamp-2 delivers strong signals to two sets. It has a built-in splitter. Great for color TV. List \$38.95."

"Supposing I don't want to lay out the few extra dollars for the Vamp-2?"

"Simple solution. The new Blonder-Tongue Vamp-1... the best one-transistor model on the market. Lists at \$25.50."

(This message was paid for out of the gross profits of BLONDER-TONGUE, 9 Alling St., Newark 2, N.J.)

Circle 21 on literature card

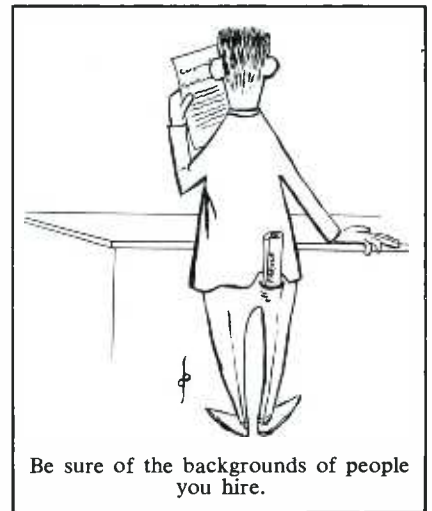

Be sure of the backgrounds of people you hire.

the people you hire.

According to bonding-company statistics, 50% of all employees are subject to temptation. Smart employers minimize the temptation by keeping a tight control on cash, equipment, and parts. This requires paying rigorous attention to invoices and maintaining a thorough system of perpetual inventory.

Another basic precaution is to insist that key personnel take their regularly authorized vacation time. This policy often discourages tampering with the books because most embezzlers worry about being discovered during an absence.

The most important deterrent of all is to let employees know that you are aware of the problem and fully prepared to deal with it. Embezzlers are initially tempted by obvious weaknesses in the records system that are allowed to exist when the manager is careless or indifferent.

Cash and noncash thefts are a constant threat to any business. Exactly how serious that threat will be to your business depends entirely on the pains you take to avoid it. ▲

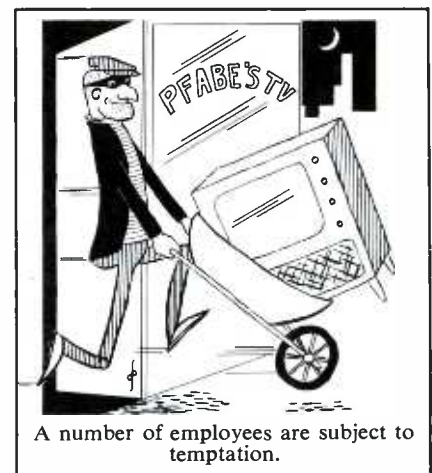

A number of employees are subject to temptation.

you get **PRODUCT PLUS** *from your Sylvania Distributor*



The value of a name Dealers have long found that SILVER SCREEN® 85 picture tubes move off the shelves fast. Why? One big reason is the tube's precision-engineered features. Another is that through the years these same features have created the guaranteed acceptance of a *name*—SILVER SCREEN 85. ■ In picture tubes no brand name approaches the assured recognition of SILVER SCREEN 85 tubes. To your customers, the name means built-in quality and long life dependability. To you, SILVER SCREEN 85 picture tubes mean sales, profits, fewer callbacks, better satisfied customers. ■ Sylvania values that acceptance and safeguards it by applying every new research and development technique for product improvement. That's why the newest SILVER SCREEN 85 picture tubes have longer life and greater product uniformity. ■ Stay with the *quality* name in TV picture tubes—SILVER SCREEN 85. See your Sylvania Distributor.

SILVER SCREEN 85 picture tubes are made only from new parts and materials except for the envelopes which, prior to reuse, are inspected and tested to the same standards as new envelopes.

SYLVANIA
SUBSIDIARY OF
GENERAL TELEPHONE & ELECTRONICS **GTE**

NEW CAPABILITIES IN: ELECTRONIC TUBES • SEMICONDUCTORS • MICROWAVE DEVICES • SPECIAL COMPONENTS • DISPLAY DEVICES

Circle 22 on literature card

ALL TAPE HEADS WEAR OUT

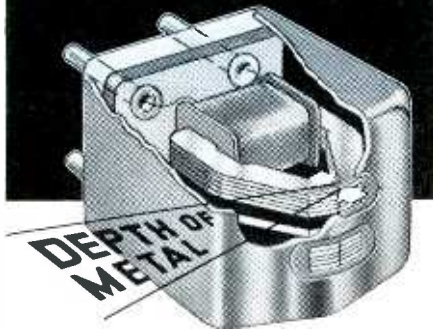

...and that means solid profit for you!

Magnetic tape itself is the real cause of head wear! The abrasive action of tape as it passes over the head face gradually wears away the **depth of metal** found on a new head (see above). Wear is nearly always uneven, and as the head wears out, it becomes impossible to achieve good contact between the head gap and the signal recorded on the tape. Poor tape-to-gap contact causes severe high frequency losses and erratic outputs — when this occurs, the brilliant realism of tape is lost! Head wear should NOT be permitted to reach this point — much less go beyond it to the limit where the gap actually begins to open up.

NORTRONICS

REPLACEMENT PROGRAM PUTS YOU INTO THIS PROFITABLE FIELD!

By replacing worn heads with new Nortronics professional type laminated heads, total sound response — particularly in the higher frequencies — is immeasurably improved, and your customers can once again enjoy maximum performance from their tape systems. Laminated heads have the added feature of longer life due to 50% more **depth of metal** at the gap than the solid-core heads. The Nortronics Tape Head Replacement Program, with "Quik-Kit" accessories, makes it possible for you to offer replacements for more than 500 different recorders . . . opens up new sales and service business! CHECK into the profit-packed Nortronics Tape Head Replacement Program NOW!

"Music sounds best on Tape—
Tape Sounds Best with Nortronics Heads"

Nortronics

8161 10th Ave. N., Minneapolis 27, Minn.

Circle 23 on literature card



Notes on Test Equipment

analysis of test instruments . . . operation . . . applications

by Stephen Kirk

Compact Oscilloscope

Because of its small size, the 3" scope is finding more and more use in servicing, both on service benches and in service trucks. EICO's new 3" scope (Fig. 1) measures just 8 1/2" x 5 3/4" x 11 1/4" and is hardly larger than an average VTVM. It has a flat-faced CRT with a mu-metal neck shield that minimizes the effects of stray magnetic fields. A 1500-volt high-voltage power supply assures plenty of brightness, and the low-voltage supply is regulated to assure stability. Jacks on the rear panel are provided for direct connection to the vertical plates. A Z-axis jack is also provided on the panel.

The 430 uses a 6BL8 as vertical input amplifier (Fig. 2). The input signal is fed into the grid of the triode section through a HI-LO (100:1) frequency-compensated attenuator switch. The output from the cathode is fed to a 10K VERT GAIN control in the grid circuit of the pentode section.

From the plate of the pentode section the amplified signal is applied to a 12AU7 connected for grounded-grid phase splitting. The push-pull outputs of the 12AU7 are applied to the vertical deflection plates of the CRT. A VERT POSITION control varies the DC balance of the 12AU7 by changing the grid bias and consequently the plate voltage of one section. Since the CRT plates are connected directly to the 12AU7 plates, the change in plate voltage moves the spot on the CRT face. Frequency response of this vertical-amplifier circuit is approximately flat from 2 cps to 500 kc, but is down 6 db at 1 mc; sensitivity is close to 75 mv rms for 1" deflection.

The horizontal amplifier uses two



Fig. 1. This oscilloscope is versatile although only a little larger than an ordinary VTVM.

12AU7's and has a frequency response from 2 cps to 350 kc. It has somewhat less gain than the vertical-amplifier circuit.

The sweep circuit operates from 10 cps to 100 kc in four overlapping ranges. Sync is derived internally; it automatically locks in the desired waveform but may be disabled with a front-panel switch when external sync voltage is desirable. The sync and sweep circuit uses a 6D10 triple-triode compactron.

The power-supply section contains a 1V2 high-voltage rectifier, a 6X4 low-voltage rectifier, and an 0A2 regulator for the 150-volt output.

We used the 430 for just about every test purpose except tracing chroma sig-

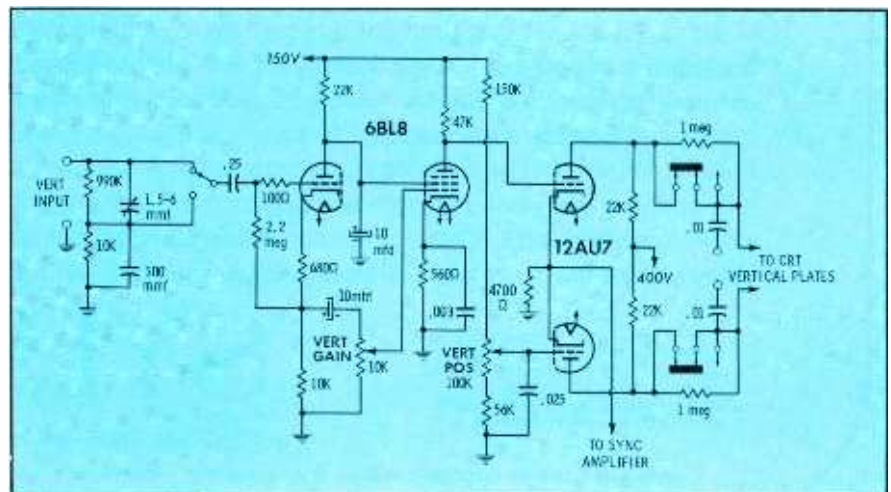
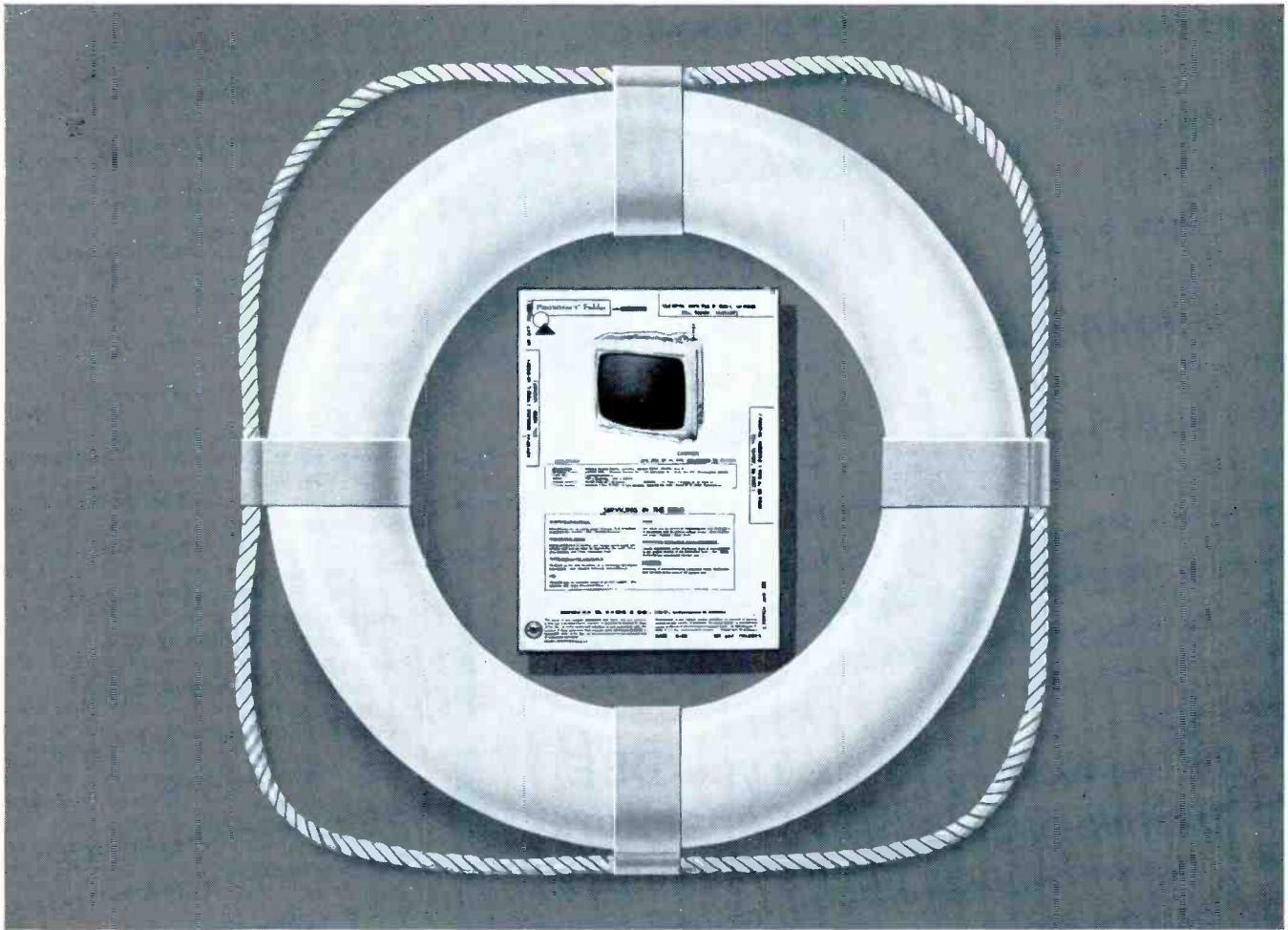

Fig. 2. The vertical-amplifier circuit of the EICO Model 430 uses two dual-purpose tubes.



"It's a lifesaver."

We didn't say it. A lot of technicians have used these very words to describe PHOTOFACT. One particular letter (unsolicited) says it like this:

"I wouldn't think of being in business without PHOTOFACT. It's a lifesaver."

Others say they're sunk without PHOTOFACT. We don't really expect anyone to "drown" without it, but we do know it saves time and saves trouble and floundering around. We do

know it often means all the difference between making a profit and not.

There are over 40 "lifesaving" features in every PHOTOFACT Folder, time-saving features to show you the way to *fast* TV-radio troubleshooting. (Really keeps you on top of those tough-dog jobs.)

Users don't measure PHOTOFACT by its pennies-per-page cost. It's the time-saving, profit-making worth of

PHOTOFACT that counts.

Of course, you can get along without PHOTOFACT—a few do—and maybe they're making a living. But it's the hard way.

Doesn't it make good sense to see your Sams Distributor today for details on an Easy-Buy PHOTOFACT Library and Standing Order Subscription?

Or use the coupon below.

A PHOTOFACT LIBRARY PAYS ITS OWN WAY—

Now, more than ever, it pays to own PHOTOFACT—the world's finest TV-radio service data. Now, you can start or complete your PHOTOFACT Library this Easy-Buy Way:

Only \$10 down • 30 months to pay • No interest or carrying charges • Prepaid transportation • Add-on privilege of a year's advance subscription to current PHOTOFACT on the same Easy-Buy contract • Save 30¢ per Set—special \$1.95 price applies on Easy-Buy (instead of the regular \$2.25 price).

4 Ways to Select Your PHOTOFACT Library: 1. Complete your present PHOTOFACT Library. 2. Order a PHOTOFACT "Start-er" Library—180 Sets (Sets 301 to 480—coverage from 1955 to 1960—only \$11.36 per month). 3. Order by brand name and year—see the handy selection chart at your Distributor. 4. Order a complete PHOTOFACT Library—get FREE file cabinets, *plus* a selection of invaluable books and Electronics Courses.

SEE YOUR SAM'S DISTRIBUTOR FOR FULL DETAILS, OR MAIL COUPON ▲

Howard W. Sams & Co., Inc., Dept. PFF-7 4300 W. 62nd St., Indianapolis 6, Indiana		
<input type="checkbox"/> Send FREE Photofact Cumulative Index <input type="checkbox"/> Send full information on Easy-Buy Plan <input type="checkbox"/> Enter my Photofact Standing Order Subscription		
My Distributor is _____		
Shop Name _____		
Attn. _____		
Address _____		
City _____ Zone _____ State _____		

IT PAYS TO USE AEROVOX!

Now
the Best
Choice is
Yours...



New Aerovox Type DBE Dipped Bi-Electric Capacitors are now available!

Yes, we've rounded out our line of top-quality paper film capacitors to provide you with your choice of the most up-to-date and dependable replacement units available anywhere. Your Aerovox distributor can now supply your every need for the new Type DBE Dipped Bi-Electric capacitors, designed and manufactured to meet the highest possible reliability standards. They're packaged in the same handy see-thru plastic bags as the popular Aerovox Type BE units, sealed for your protection. See your Aerovox distributor salesman or counterperson for complete details. Technical data is yours for the asking... simply ask for a copy of Bulletin NPJ-130.

Whether your choice is the new Type DBE... or Type BE and V161 Mylar® capacitors used regularly by successful technicians everywhere... standardize on Aerovox for every service job. Why take unnecessary chances—protect your reputation and your profits by ordering "Aerovox only" from your local Aerovox distributor.



BE Bi-Electric® Mylar Paper Bypass Tubulars combine the special Aerolene® impregnant and exclusive Polycap® case to bring you a truly superior bypass capacitor. No cracking or chipping problems, even when leads are extended for axial mounting. Ask for Bulletin NPJ-118.



V161 Aerofilm® Mylar Capacitors are extremely stable axial lead units featuring the Polycap case and epoxy end seals which will not flow, soften or melt at any operating temperature! They combine high insulation resistance and low dielectric absorption and power factor.

*Registered DuPont trademark



AEROVOX CORPORATION
DISTRIBUTOR DIVISION, NEW BEDFORD, MASS.
Technical Leadership—Manufacturing Excellence

nals in a color set. It is quite adequate for tracing hum or loose ground connections, troubleshooting AGC circuits, locating sync distortion, checking gain in transistor radios, etc.

We fed square waves to the vertical input terminals at several frequencies ranging from 100 cps to 10 kc. There was no distortion of the square-wave pattern at any of these frequencies. Consequently, the scope would be useful in testing audio amplifiers. Be sure to check audio amplifiers with a suitable load on the amplifier output; otherwise the tests may well be meaningless. The best approach is to use the exact load into which the amplifier is designed to operate, such as a speaker or speakers. Nearly all the low-priced amplifiers we tested showed some phase shift and gave somewhat less than the ideal output wave-shape. One hi-fi amplifier reproduced a 5-kc square wave satisfactorily using a resistive load, but when it was operated into a speaker there was some slight tendency to ring at about 4 kc. This was evidently due to phase shift in a feedback network. Paralleling another speaker across the one already connected virtually eliminated the ringing in this case.

We used the 430 to check some transistor radios by following signals through the IF and AF stages. We applied the output of a signal generator to the input of the radio and then observed the output of each radio stage with the scope. By checking through the set in this manner, we soon learned where a loss or weakening of the signal was occurring.

For further information, circle 55 on literature card

Visual-Aural Tracer

The Heath Model IT-12 Signal Tracer (Fig. 3) is designed as a useful tool in tracking down weak, distorted, noisy, or missing signals in radios and audio amplifiers.

Fig. 4 is a functional block diagram of the IT-12. Basically, it is a three-stage audio amplifier equipped with a 3' input cable terminated in a switch-selected RF-AF probe. When the probe is switched to the RF position, a diode detector rectifies the incoming signal; in the AF position the signal is fed straight



Fig. 3. Signal tracer includes a noise-test function and has aural and visual indication.

Find it and Fix it in 1/2 the time!

EASILY SOLVES "TOUGH DOGS"... INTERMITTENTS... ANY TV TROUBLE



MODEL
1076

TELEVISION ANALYST
BLACK & WHITE AND COLOR

ANALYST

By Easy Point-to-Point Signal Injection, You see the Trouble on the TV Screen and Correct it—Twice as Fast and Easy!

Simplified technique stops lost hours never recovered on "tough dogs", intermittents, and general TV troubleshooting. This one instrument, with its complete, accurate diagnosis, enables any serviceman to cut servicing time in half... service more TV sets in less time... satisfy more customers... and make more money.

With the Analyst, you inject your own TV signals at any time, at any point, while you watch the generated test pattern on the picture tube of the television set itself. This makes it quick and easy to isolate, pinpoint, and correct TV trouble in any stage throughout the video, audio, r.f., i.f., sync and sweep sections of black & white and color television sets—including intermittents. No external scope or waveform interpretation is needed. Checks any and all circuits—solves any performance problem. Gives you today's most valuable instrument in TV servicing—proved by thousands of professional servicemen everywhere.

Available on Budget Terms. As low as \$30.00 down.

Net, \$32995

SIMPLIFIES COLOR TV SERVICING, TOO

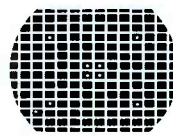

Enables you to troubleshoot and signal trace color circuits in color TV sets, or facilitate installation.

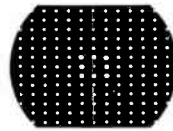

Generates white dot, crosshatch and color bar patterns on the TV screen for color TV convergence adjustments.



Generates full color rainbow display and color bar pattern to test color sync circuits, check range of hue control, align color demodulators. Demonstrates to customers correct color values.

Time-Saving, Money-Making Instruments Used by Professional Servicemen Everywhere



Model 960 Transistor
Radio Analyst



Model 360 V O Matic
Automatic VOM



Model 375 Dynamatic
Automatic VTVM



Model 700 Dyna-Quik
Tube Tester



Model 44 CRT
Rejuvenator Tester

See Your B&K Distributor
or Write for Catalog AP21-R



B & K MANUFACTURING CO.

Division of DYNASCAN CORPORATION

1801 W. BELLE PLAINE AVE. • CHICAGO 13, ILL.

Canada: Atlas Radio Corp., 50 Wingold, Toronto 19, Ont.

Export: Empire Exporters, 253 Broadway, New York 7, U.S.A.

Circle 25 on literature card

July, 1964/PF REPORTER 49

ARE YOU IN THE TV SERVICE BUSINESS?

Here's a Calling Card that will guarantee customer satisfaction. While on your next service call, leave this MOSLEY calling card

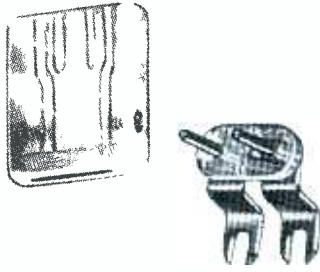

FAST * SIMPLE * SOLDERLESS

The MOSLEY 304 Input Adapter is an ideal connector for TV sets, boosters, etc. Just attach to the antenna terminal strip on chassis of TV and mate with the MOSLEY 311 Universal Transmission Line Socket.

THE FINISHING TOUCH FOR A LASTING IMPRESSION

The installation provides a handy plug-in antenna line for Customer Convenience!

A moment of your time, at a cost of pennies, will buy you a Public Relations job that Pays Off In

- * CUSTOMER SATISFACTION
- * REPEAT CALLS
- * REFERRALS

Send for your **FREE Mosley Catalog**. The one and only complete line of TV/FM accessories available on the market today!

Please send me your catalog containing the complete line of TV/FM installation accessories. ①

NAME

ADDRESS

CITY/STATE

Mosley ELECTRONICS, INC.
4610 NORTH LINDBERGH BOULEVARD
BRIDGETON, MISSOURI, 63044.

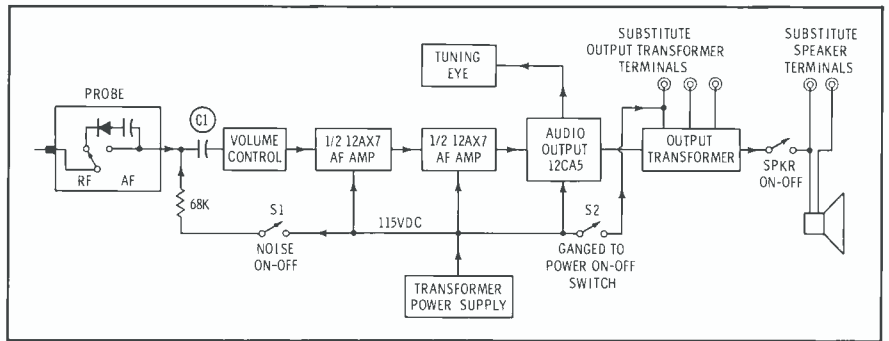

Fig. 4. Three stages of amplification are used in the signal-tracer function of the IT-12.

through the probe. The output of the tracer goes to a speaker and to a tuning eye to give both aural and visual indication of input-signal strength.

The output transformer or speaker in the tracer may be substituted for those suspected of being defective in sets by making connections to front-panel binding posts. When using the output transformer as a substitute, the tracer power switch should be turned off; this disconnects the B+ voltage and eliminates a possible shock hazard or a false indication of trouble. A separate switch turns the speaker OFF or ON as desired.

Noise switch S1 connects the B+ voltage from the tracer through a 68K resistor to the probe tip (in the AF position). This function is used for finding noisy electronic components by connecting the probe and ground wire across the suspected part (Fig. 5). If the current passing through the component is smooth, there is no voltage fed through capacitor C1 to the tracer, and nothing is heard in the speaker except when making the initial connection. However, if the component is noisy, the current through it is erratic, and the voltage drop across it varies accordingly. These voltage variations are fed to the high-gain amplifier, and crackling or frying noises emerge from the tracer speaker.

Electronic components are not damaged in the noise check since test current is limited to less than 2 ma. Components with breakdown ratings lower than 100 volts (such as transistors and transistor parts) should not be tested, however, unless the probe-tip voltage is reduced by a noise-free resistor (check it first with the tracer) of the correct size. For example, you can check parts rated at

50 volts by using a 47K resistor; use a 22K resistor for 25-volt parts and a 6.8K resistor for 10-volt parts. The auxiliary resistor should be connected between the probe tip and ground lead. The component to be tested is then placed in parallel with this resistor.

There is no scientific way of predicting just how the tracer will act under every circumstance, but a little experience in using it on both good and bad circuits will show you about what to expect. If a strong station signal is available, a discernible signal can be detected by the IT-12 at the loop antenna or first mixer areas. In weak-signal areas, the first usable signal may appear at the plate of the mixer. Sometimes even here, if the station is weak, there may be more hum than signal.

Fig. 6 shows the arrangement of a typical receiver. If the signal at point B is masked by hum, you can do one of three things. You can (1) move to point D, and if the signal is satisfactory there, assume it is satisfactory at B; (2) provide a stronger signal by placing a four- or five-turn wire loop near the antenna and connecting it to a signal

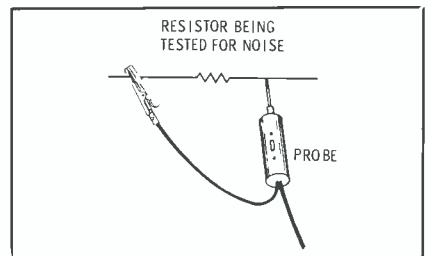

Fig. 5. Resistors and other components can be checked for noise using the connection shown.

PRECISION TUNER SERVICE

P. O. BOX 272

1200 S. WALNUT ST.

BLOOMINGTON, IND.

EDISON 99653

7.50
V or U

COMBO PLUS
9.95 POSTAGE

6 MONTH WARRANTY



All Types T.V. Tuners Cleaned, Repaired and Aligned to Factory Specifications. Same day in shop service on most Tuners. Price Includes Minor Parts, Major Parts at Cost Price. We use Original Parts if possible. State Make Model and Enclose all Parts and Tubes. Pack Well and Insure.

ALSO HAVE LARGE STOCK OF EXCHANGE TUNERS. WRITE FOR TYPES AND PRICES.

Circle 28 on literature card

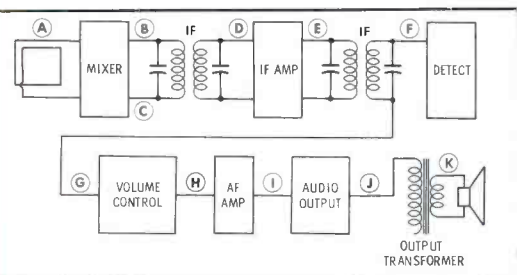

Fig. 6. The points in a typical tube-type receiver at which the tracer can be connected.

generator; or (3) connect the tracer ground to point C, placing a low impedance (for audio) across the input of the tracer and thus eliminating the hum that occurs when the tracer gain must be turned high. Remember, though, *don't touch the tracer case and B-minus* when you are making this test — it'll jar you! At point E the signal should be strong enough, even on a weak station, that the tracer volume can be turned down and hum will not be a problem. Signals past point G should be traced using the AF position of the probe.

Transistor radios can be checked with the IT-12, especially after you become familiar with it. As with tube radios, it is necessary only to prepare yourself by checking out both good and bad units. Usually, the signal at the base of either the mixer or the first IF transistor is too weak to be heard on the tracer, unless a rather strong station signal is present. However, a usable signal should be present at the collector of the first IF stage. (Don't forget, though — you can use a signal generator to provide the amount of signal you want.)

Using the tracer to check distortion in a transistor radio requires a little more skill than it does in a tube radio. For example, signals at the base or collector of an audio amplifier may be seriously distorted when inserted into the high-impedance input of the tracer, yet they may sound perfectly normal in the speaker of the transistor radio. However, with experience you can learn to make mental corrections that nullify this disadvantage to a great extent.

The IT-12 can be used to check phono cartridges, microphones, public-address systems, etc. There is ample gain for testing any crystal, ceramic, or dynamic microphone; in fact, with a good microphone the gain control cannot be advanced more than a few degrees before feedback occurs.

The noise check on the IT-12 is a valuable feature of this instrument. We used the noise check on a public-address system that produced intermittent pops and crackles. Each resistor in the unit was checked with one end disconnected to avoid parallel paths. Two produced a slight frying noise. Since heat was the likely cause of the trouble, a soldering iron was brought near the resistors. In one the frying increased only slightly with heat applied, but in the other the application of heat caused intense crackling. As a precaution, we replaced both resistors. When we turned the amplifier on, the silence was beautiful to hear . . .

Another case involved a car radio that seemed to be receiving its own private

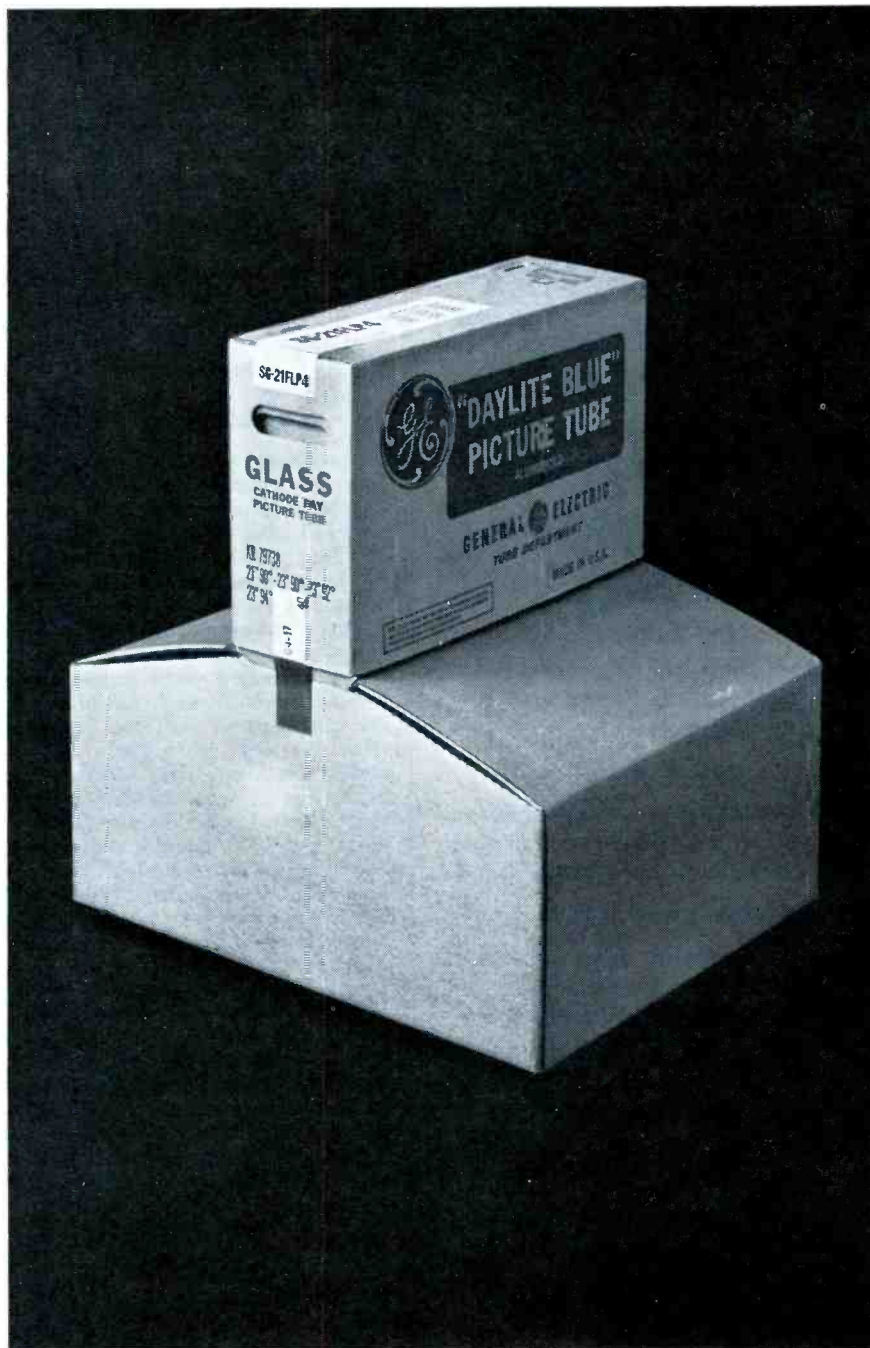

New T-Box

(It's what's inside that counts)

This is the new General Electric T-Box picture tube carton. It reduces the amount of space needed for stocking and transporting. It's easy to carry, easy to open . . . dust free and stronger. But it's the picture tube* inside that really counts.

**All new parts and material in a reused envelope.*

Progress Is Our Most Important Product

GENERAL  ELECTRIC

Circle 29 on literature card

Coming in the AUGUST issue special antenna section



Servicing Master Antenna Systems

- • • an inside look at signal distribution, possible defects, and how to solve them.

Antenna Systems Can Be Safe

- • • regulations should be observed and proper procedures followed during installation and repair.

Techniques For Selling Antennas

- • • UHF and FM stereo present a marvelous opportunity for increasing sales—if properly approached.

plus . . .

Notes on Test Equipment

Symfact

Previews of New Sets

Video Speed Servicing

Enter my subscription to PF REPORTER and send me free book(s) checked.

- 3 Years \$10.00 2 Years \$8.00 1 Year \$5.00
- The Troubleshooter's Handbook No. 2
- Servicing Industrial Electronics
- Servicing TV from Tuner to Picture Tube
- Symfact Handbook

Check one of above for each year you subscribe

- Bill Me Remittance Enclosed
- Extend Present Subscription

Please Check Your Business Classification

- Owner, Mgr. Employee Service Mgr.
- Independent Radio, TV Serviceman Retailer with Service Department
- Industrial Electronics Service Other (Specify occupation and title)

Name _____

Firm _____

Address _____

City _____ State _____ Zip Code _____

Take this coupon to your distributor, or mail to: Howard W. Sams & Co., Inc., 4300 W. 62nd Street, Indianapolis, Indiana

thunderstorm — rain or shine. We found that removing the mixer tube eliminated the noise; this strongly indicated trouble in the RF stage. After looking over the circuit, we found a broadband coupling transformer between the RF stage and mixer. We first checked with the IT-12 connected between the primary and secondary windings, but this test produced no noise. Then the probes were connected across the primary winding. The intermittent bursts of noise in the tracer speaker immediately revealed that this winding was defective.

For further information, circle 56 on literature card

Combination Tester

The Mercury Model 301 (Fig.7) combines the functions of a tube tester, a 20,000 ohms-per-volt VOM, and a picture-tube tester-rejuvenator. Such a combination provides just about everything in the way of test equipment that is needed on the average service call.

Fig. 8 shows the basic layout of the 301. The straightforward arrangement of this combination tester makes using it convenient. Tube-check functions are on the center panel; the tube sockets surround the large (6" x 4 1/4") open-faced meter. Just about every tube type made in the last 25 years is listed in the tube chart supplied with the tester; we counted more than 3300 different ones, including new foreign and industrial types. The tube tester setup is made by the adjustment of six switches (5 rotary, 1 slide). Shorts and grid leakage are indicated by a neon bulb. A second neon bulb acts as a pilot lamp.

Just under the pilot lamp is the off-on function-selector switch. Moving this switch to VOM transfers the meter to act as indicator for the VOLTS-OHMS panel on the right side. Two test leads plug into front-panel pin jacks. We used the VOM section of the 301 in just about every imaginable way. Even with all the functions and indications required of the meter, the orderly arrangement of the scales made each range stand out clearly with no confusion. There are DC and AC voltage ranges of 15, 75, 150, 300, 750, and 1500 volts. There are current scales of 75 ua, 7.5 ma, 75 ma, and 15 amps. Ohms scales of Rx1, Rx100, and Rx10K give midscale readings of 12 ohms, 1200 ohms, and 120K. Two ca-



Fig. 7. A combination tester providing functions of VOM, tube tester, CRT rejuvenator.

it's new

Jackson

MODEL 825 PICTURE TUBE TESTER/BOOSTER



NOW A PICTURE TUBE TESTER-BOOSTER WITH THE FEATURES WANTED MOST BY THE TV SERVICE-MEN. COLOR KEYED-PUSH BUTTON OPERATED FOR EASE AND SPEED. DESIGNED TO MAKE MORE ACCURATE CHECKS THAN ANY OF THE OTHER MAKES NOW IN EXISTANCE. COMPLETELY VERSATILE FOR BLACK AND WHITE OR COLOR TV PICTURE TUBES.

FEATURES

12 SEPARATE HEATER VOLTAGES INCLUDING COLOR-SEPARATE CONTINUITY-LEAKAGE CHECKS-LINE INDICATOR CONTROL FOR ACCURATE VOLTAGES-FM TUNING EYE TUBE INDICATES CONTINUITY OR LEAKAGE-NO SEPARATE LIGHTS TO INTERPOLATE-PUSH BUTTON OPERATED EMISSION TEST-PICTURE TUBE CUT-OFF TEST-LIFE TEST-REMOVES SHORTS-WELDS CATHODES-BOOSTS PICTURE TUBE BACK TO LIFE-GRID GUARD LIMITS PEAK CURRENT FOR PROTECTION OF PICTURE TUBE-SEPARATE VARIABLE VOLTAGES APPLIED TO G1-G2 OF PICTURE TUBE-ANGLED VIEW ROLL CHART-TUBE SET-UP INFORMATION ALWAYS AT YOUR FINGER TIPS-CHECKS EACH COLOR GUN SEPARATELY-PLUG-IN SOCKET CABLE FOR EASY REPLACEMENT OR REPAIR-EASY TO KEEP UP-DATED

DEALER NET \$119.95

MODEL 805 VACUUM TUBE VOLTMETER



The new model 805 VTVM features the Weston Taut Band Suspension Meter. Taut Band suspension eliminates pivots and jewels. No movement springs eliminates pivot friction and error due to pivot fall-over. It may be operated in any position without degrading performance and is four times more sensitive than conventional movements.

FEATURES

DIRECT PROBE: NO PROBE SWITCHING NECESSARY-STATIC FREE FACE-BURN OUT PROOF METER-6" METER FACE-A.C. ACCURACY: 5% OF FULL SCALE-D.C. ACCURACY: 3% OF FULL SCALE-FREQUENCY: 1DB, 20 CYCLES TO 3 MEGACYCLES-D.C. INPUT RESISTANCE: 10 MEGOHMS-A.C. INPUT IMPEDENCE: .2 MEGOHMS SHUNTED BY 150 MMF-OHM METER RESISTANCE RANGES: 0-1K, 10K, 100K, 1MEG, 10MEG, 100MEG, 1000MEG-D.C. RANGES: 0-1, 5, 10, 50, 100, 500, 1000-R.M.S. RANGES: 0-1, 5, 10, 50, 100, 500, 1000-ZERO CENTER REFERENCE FOR ANY D.C. RANGE-P.P. RANGES: 0-2.8, 14, 28, 140, 280, 1400, 2800

DEALER NET \$79.95



JACKSON ELECTRICAL INSTRUMENT COMPANY
124 McDONOUGH ST., DAYTON, OHIO

Circle 30 on literature card

capacitance scales allow accurate readings in the range from about .001 to 80 mfd. Leakage in a capacitor makes the measured capacitance value above the marked value. Remember, however, that it is normal for paper and ceramic capacitors to measure slightly above their indicated values; don't mistake this increased reading for leakage.

On the left side of the 301 panel is the CRT TESTER-REACTIVATOR section. The function switch of this section has five positions: (1) FILAMENT CONTINUITY—LIFE TEST. (2) G-1 QUALITY, (3) G-2 SCREEN, (4) G-4 FOCUS ANODE, and (5) CATHODE. A picture tube with ample emission should read in the "good" portion of the meter in all these positions except number 1; this position provides a filament continuity check. Since the filament is turned off, this position is also designated as the LIFE TEST. A tube with a short life expectancy gives an emission reading that declines rapidly when the filament is turned off, whereas a tube with longer life expectancy gives a reading that declines much more slowly. A neon bulb is used to indicate leakage or shorts between CRT elements, and provision is made for checking picture tubes with 2-, 6-, or 8-volt heaters.

Picture-tube checking with the 301 is easy. The adapter box is small enough that it can almost always be placed on the picture tube with ease and without bumping into something else nearby. One interesting thing happened on the very first CRT we checked. The tube was working reasonably well, but when we attempted to check it with the 301 we got no emission reading. Since the 301 checks individual elements, it occurred to us that perhaps we should remove the focus jumper used on this particular tube and try again. With the jumper removed, a reading was obtained.

We tried reactivating three different picture tubes. The operation was successful with one tube, but the other two were considered to be beyond repair.

The socket adapter box that comes with the 301 has sockets for all monochrome and color tubes. Individual color guns can be checked by simply rotating the switch on the box for RED, BLUE, or GREEN. The adapter-box cable plugs into the octal socket on the CRT test section of the front panel. This feature means the adapter box can be changed quickly and easily if it should ever become obsolete. ▲

For further information, circle 57 on literature card

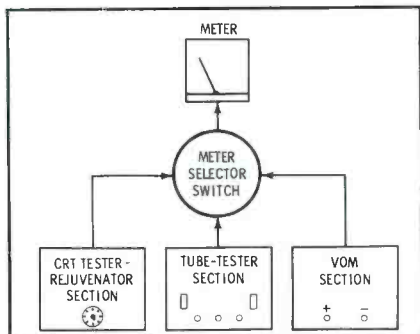
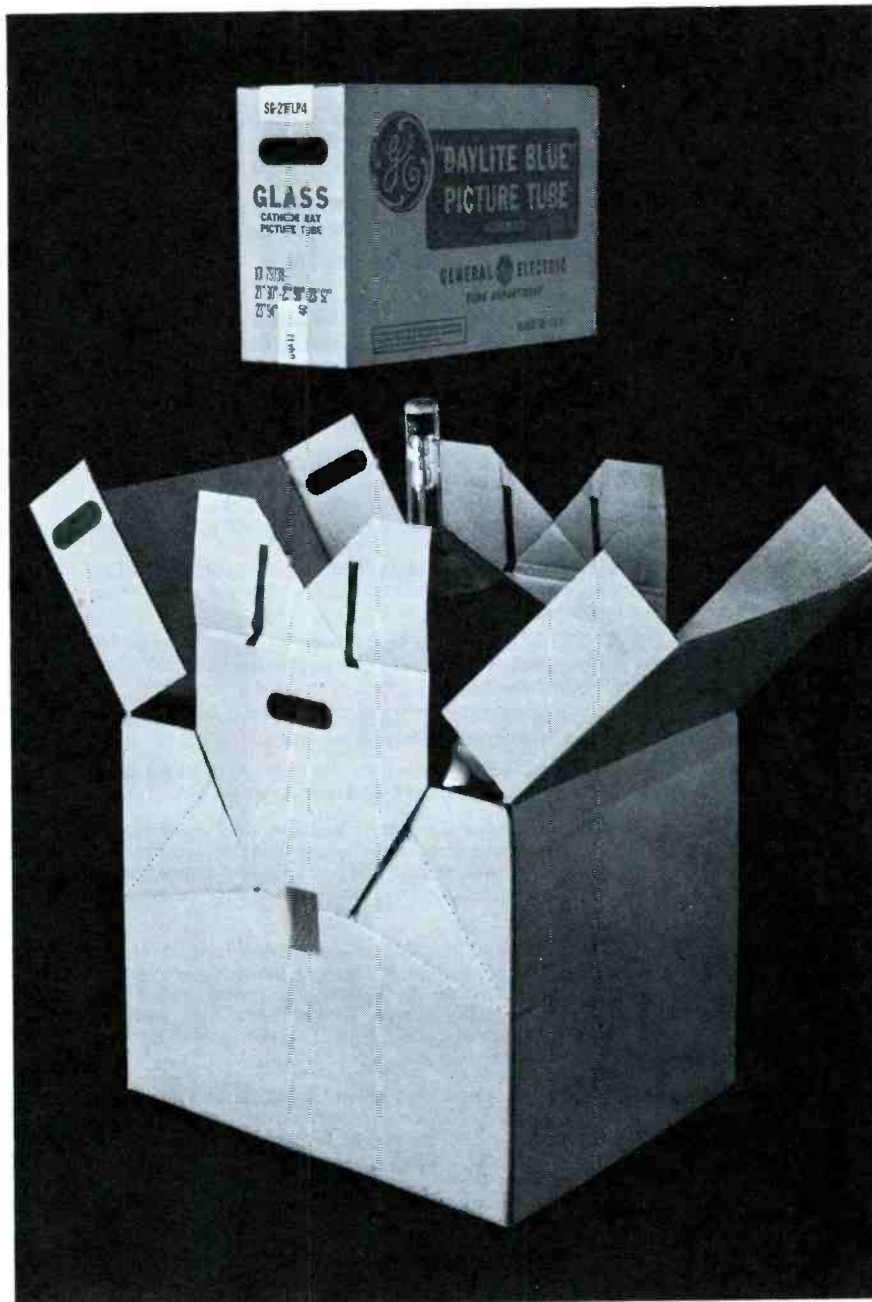

Fig. 8. Diagram showing the basic operational layout of Mercury 301 combination tester.



It's the G-E straight-gun picture tube

The General Electric straight-gun picture tube* needs no ion trap. It fires electrons with precision accuracy to give sharply resolved pictures . . . up to 80% brighter. This cuts the time necessary for installation and adjustment . . . reduces call-backs . . . saves time and money for you.

*All new parts and material in a reused envelope.

Progress Is Our Most Important Product

GENERAL ELECTRIC

Circle 31 on literature card

NEW SECO MODEL 107B TUBE TESTER

SPEEDS REPAIRS, DETECTS SLEEPERS

● 8 sockets wired to 14 lever type pin selectors for testing tubes circuit by circuit!

● 40 prewired sockets accommodating 63 basic arrangements for testing thousands of popular tube types with no set-up data required!



FOOLPROOF READINGS—all test information reads on one meter and one scale! Eliminates errors that can be made reading off closely packed multiple scales. Wide sweep increases accuracy of readings.

3 COMPREHENSIVE TESTS find tube faults that slip by other testers that cost much more. Pull out more "sleepers" on your first try—save time and call-backs.

● **GRID CIRCUIT TEST** makes up to 11 simultaneous checks for leaks, shorts and grid emission—indicates "hard to find faults" that conventional short tests pass by.

● **DYNAMIC MUTUAL CONDUCTANCE TEST** indicates relative transconductance—incorporates gas error test.

● **CATHODE EMISSION TEST** provides the best method for testing pulse amplifier, power output and damper type tubes.

Readings can be made for element identification and analysis of elements for shorts. A "life" test checks for allowable drop in mutual conductance or emission current under reduced heater supply conditions. The exclusive Grid Circuit Test above is a test originated and patented by Seco.



PLUG-IN-SOCKET CHASSIS is easily replaced or interchanged to accommodate the widest possible range of tubes. In addition to 8 sockets, panel has 3 pin straighteners for 4 most popular types. Inexpensive and easy to keep up to date as new tubes appear. Plug in chassis can be customized at low cost to fit your needs.

WIDE RANGE of tube types tested includes all modern TV, radio, industrial and foreign tubes using the following sockets—seven pin, nine pin, octal, loctal, novar, nuvistor, compactron, magnoval and ten pin. Special circuit for low voltage hybrid types. Complete set-up data book is included—pages covering new tubes that appear are mailed periodically to all registered owners at no charge.

ALWAYS UP TO DATE



Model 107B \$189⁵⁰ NET

For complete information see your distributor or write:

SECO ELECTRONICS, INC.

1221 S. Clover Drive, Minneapolis 20, Minnesota

A DIVISION OF DI-ACRO CORPORATION

Circle 32 on literature card

Stereo Alignment

(Continued from Page 31)

change any oscilloscope settings, except vertical gain, from those used in checking the 19-kc amplifiers. If the oscillator is not locked with the incoming signal, the waveform will be unstable. When the correct oscillator setting is reached, the waveform will be stable, and a slight adjustment to either side of the correct setting will result in decreased amplitude and cause instability in the waveform.

The oscillator may also be adjusted for a zero beat as heard from the speakers. This zero beat occurs when the oscillator and the incoming signal are at the same frequency. To be doubly sure, adjust for zero beat and maximum amplitude simultaneously.

The method used in doubling the 19-kc frequency to 38 kc varies from one receiver to another. The method used to obtain the 38-kc signal is not important, but the adjustment of the coils is of extreme importance. The coil preceding the detector circuit is always adjusted for maximum response at 38 kc.

In most cases the remaining coils in the pilot channel are adjusted for maximum response at 19 kc. Exceptions are in a reflex circuit, such as is shown in Fig. 2, or a circuit in which a 38-kc oscillator is used. The oscillator frequency can be determined by adjusting for zero beat. If a zero beat cannot be obtained with the generator output at 19 kc, switch the generator output to 38 kc and adjust for the zero beat.

67-kc Trap Adjustment

To adjust the 67-kc trap, set the generator for a 67-kc output. With the oscilloscope connected to point D, adjust A15 for minimum signal. The 67-kc signal at this point should have a very low amplitude. Considerable noise may be visible in the scope trace; it can be eliminated either by removing an IF tube or, in the case of series filaments, by grounding the control grid of the first or second IF tube. With the IF strip disabled, the 67-kc signal from the generator will be relatively clean. Waveform W2 (Fig. 3) shows the indication from a misaligned 67-kc trap, with the IF section disabled. Waveform W3 shows the result with the trap properly

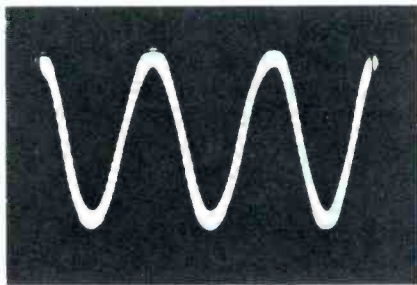

(A) Point C—W1

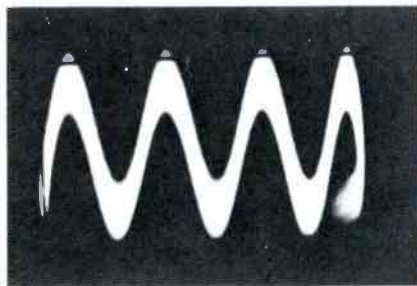

(B) Point D, trap misaligned—W2

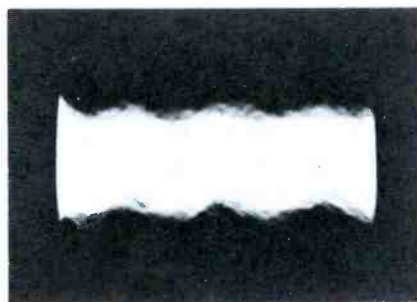

(C) Point D, trap aligned—W3

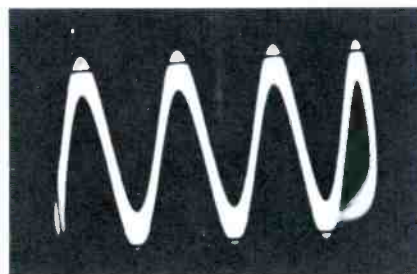

(D) One channel, good separation—W4

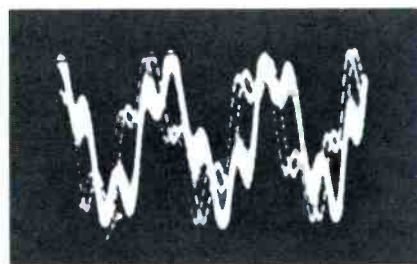

(E) One channel, poor separation—W5

Fig. 3. Waveforms obtained during the alignment of the multiplex unit shown in Fig. 1.

aligned and the IF section functioning.

Some receivers may have traps at frequencies slightly different from 67 kc. If the trap frequency is known, adjust for minimum indication at point D with the proper in-

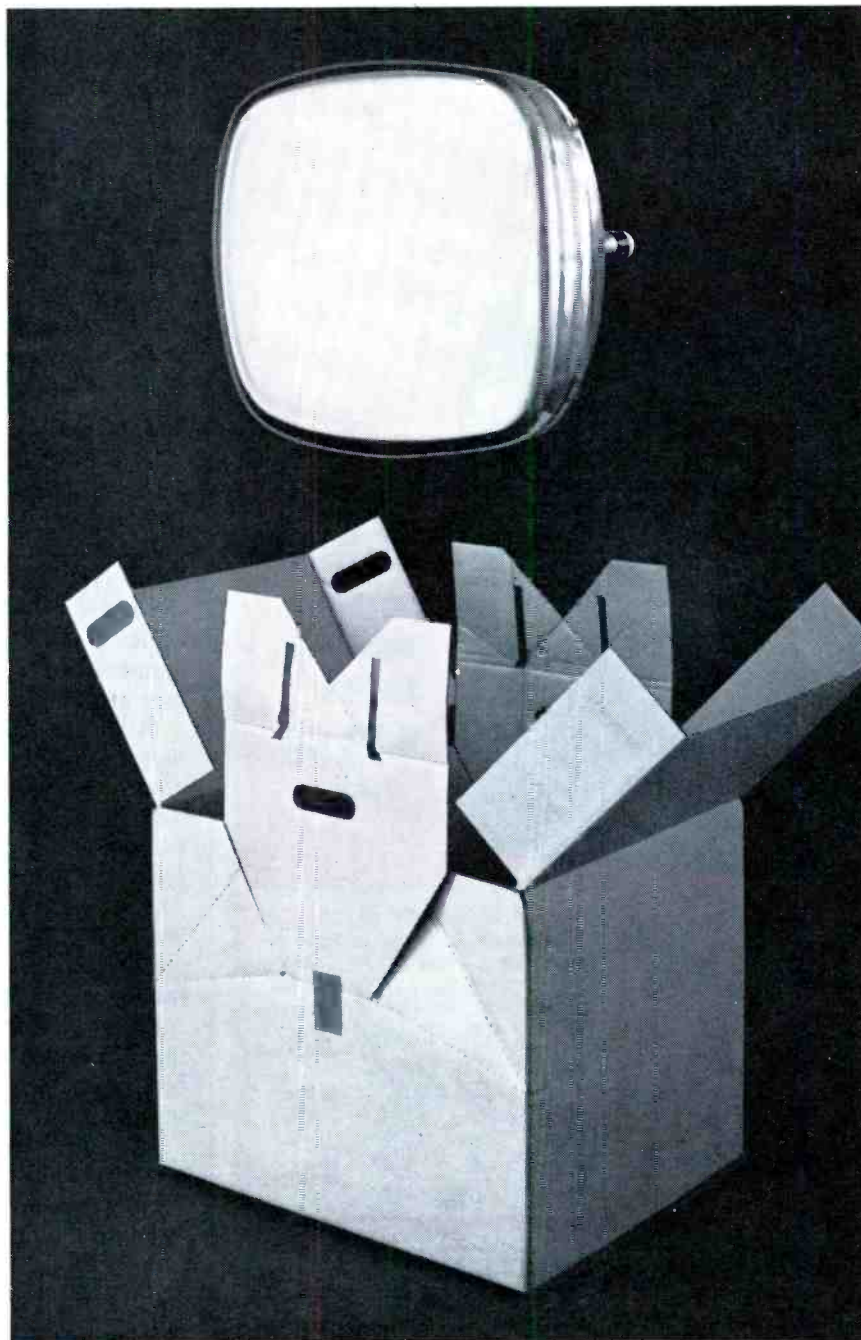

It has a brighter, “DAYLITE-BLUE” screen

General Electric’s “DAYLITE-BLUE” screen gives a sharp, clear picture. The carefully deposited phosphor has a graphite-coated, high-purity aluminum film to increase the brightness. General Electric straight-gun picture tubes* will brighten your profit picture, too.

**All new parts and material in a reused envelope.*

Progress Is Our Most Important Product

GENERAL  ELECTRIC

Circle 33 on literature card

200,000 OHMS PER VOLT

TRIPLET



Model 630-NS
VOLT-OHM-MICROAMMETER
\$99.50
SUGGESTED U.S.A. USER NET

NEW AND THE FIRST

TRIPLET SUSPENSION MOVEMENT

no pivots . . . no hair springs
no jewels . . . thus **NO FRICTION**

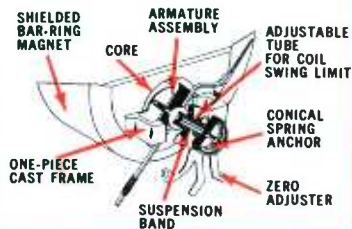

FACTS MAKE FEATURES:

- 1** 200,000 OHMS PER VOLT D.C. for greater accuracy on high resistance circuits. 20,000 OHMS PER VOLT A.C.
- 2** 5 μ a SUSPENSION METER MOVEMENT. No pivots, bearings, hair-springs, or rolling friction. Extremely RUGGED. Greater sensitivity and repeatability.
- 3** 62 Ranges, usable with frequencies through 100 Kc. Temperature compensated. 1½% D.C. ACCURACY, 3% A.C.

Low voltage ranges and high input impedance make the 630-NS especially useful in transistor circuit measurement and testing. Input impedance, at 55 volts D.C. and above, is higher than most vacuum tube voltmeters.

The unit is designed to withstand overloads and offers greater reading accuracy. Reads from 0.1 μ a on 5 μ a range. Special resistors are rigidly mounted and directly connected to the switch to form a simplified unit. Carrying cases with stands are priced from \$9.90.

TRIPLET ELECTRICAL INSTRUMENT CO., BLUFFTON, OHIO

Circle 34 on literature card

put frequency. If the frequency is unknown, adjust for minimum indication at 67 kc. If a whistle occurs when using a station signal, readjust the trap slightly for minimum whistle; one turn in either direction will usually eliminate this condition.

The 67-kc trap can often be adjusted without test equipment. Interference between the 67-kc SCA subcarrier and the second harmonic of the 38-kc signal results in a low whistle from the speakers. The proper setting of the trap can usually be obtained by adjusting for minimum whistle or interference when the receiver is tuned to an FM station transmitting both stereo and SCA subcarriers.

38-kc Bandpass

The 38-kc bandpass coil has very broad response which makes it difficult to adjust. It can, however, be adjusted quite easily during the separation test.

To check separation, set the generator for a modulated left-channel output. Connect the oscilloscope to the right-channel output. In Fig. 1, this is the junction of R55 and C54. If two oscilloscopes are available, connect the second oscilloscope to the left-channel output (the junction of R53 and C50).

Adjust the 38-kc bandpass coil (A14) for minimum indication at the right-channel output. If a separation control is used, it should also be set for minimum indication. At these settings there should be a maximum indication in the left-channel output. Next, set the generator for modulated left- and right-channel output. The proper waveform with good separation is shown as W4 in Fig. 3. Waveform W5 is an example of unsatisfactory separation. In this case less than ¼ turn of oscillator coil A12 corrected the poor separation.

Occasionally, one channel will have better separation than the other. When this happens, the best you can do is readjust the separation control for a compromise setting.

If, after completing the entire alignment of the receiver, you do not obtain satisfactory results, look for a faulty component in one of the stages. This stage can be isolated quite rapidly by repeating the alignment procedure and watching closely to see that all coils adjust as they should.

Touch-Up Procedure

A complete step-by-step procedure such as the one just described is required only if the coils are far out of adjustment. A touch-up procedure will often be adequate and can be completed easily and rapidly.

Apply a modulated left- or right-channel input signal, connect the oscilloscope to the opposite-channel output, and adjust all coils (except the 67-kc trap) for minimum indication. The separation control should also be adjusted for minimum indication. Then change the generator to the opposite-channel input. Move the oscilloscope to the other channel and check for minimum indications. If necessary, slightly retouch the coils and the separation control for compromise separation in both channels.

After aligning a few multiplex receivers, you will be surprised at the small amount of time and effort required. You will be rewarded financially, and your customers will be rewarded with the enjoyment of FM stereo at its best. ▲

"Shortcuts"

(Continued from page 33)

brator-type auto radios, but trying to service other complaints with AC is just a waste of time. This kind of "shortcut" servicing often creates time-wasting problems.

I was surprised not long ago when a fellow I consider to be a pretty good serviceman brought in an old auto radio for me to look at. The complaint was weak audio. On hooking the set to our 6-volt DC power supply, he found much to his puzzlement that it played with more than enough volume. When asked what the difference between his shop setup and my setup was, he admitted that he had checked the set with a transformer supplying 6 volts AC. "But," he hotly protested, "that set should work from AC."

"Okay," I admitted, "the set itself will work from AC, but that electromagnetic speaker needs DC across the field to produce any volume."

His unfamiliarity with shunt-fed EM speaker fields was excusable because he hadn't been in the business long enough to remember when most auto radios used EM instead of PM speakers, but his AC shortcut cost valuable time.

Working on another auto set using AC created a still more confusing side-effects problem. This set, with 12-volt tubes and a vibrator-type power supply, worked weak in the car, but on the bench it had plenty of sensitivity and volume. My look at the set was in the other fellow's shop, which accounts for its being tested with AC.

Because the set worked normally on his bench, he returned it to the car, suspecting a bad antenna. The new antenna was no improvement, so he called me in. At my insistence, he brought in the battery from the car; with it, the set showed a definite lack of sensitivity, which was traced to an open coil in the core-type tuner. After repairing the coil, we set about determining why the set played enough better with AC to hide the complaint. Voltage readings provided the answer; using the battery for power, the B+ line read about 180 volts, but with 12 volts AC powering the set, B+ increased about 100 volts.

The only conclusion to be drawn from this case is that either the vi-

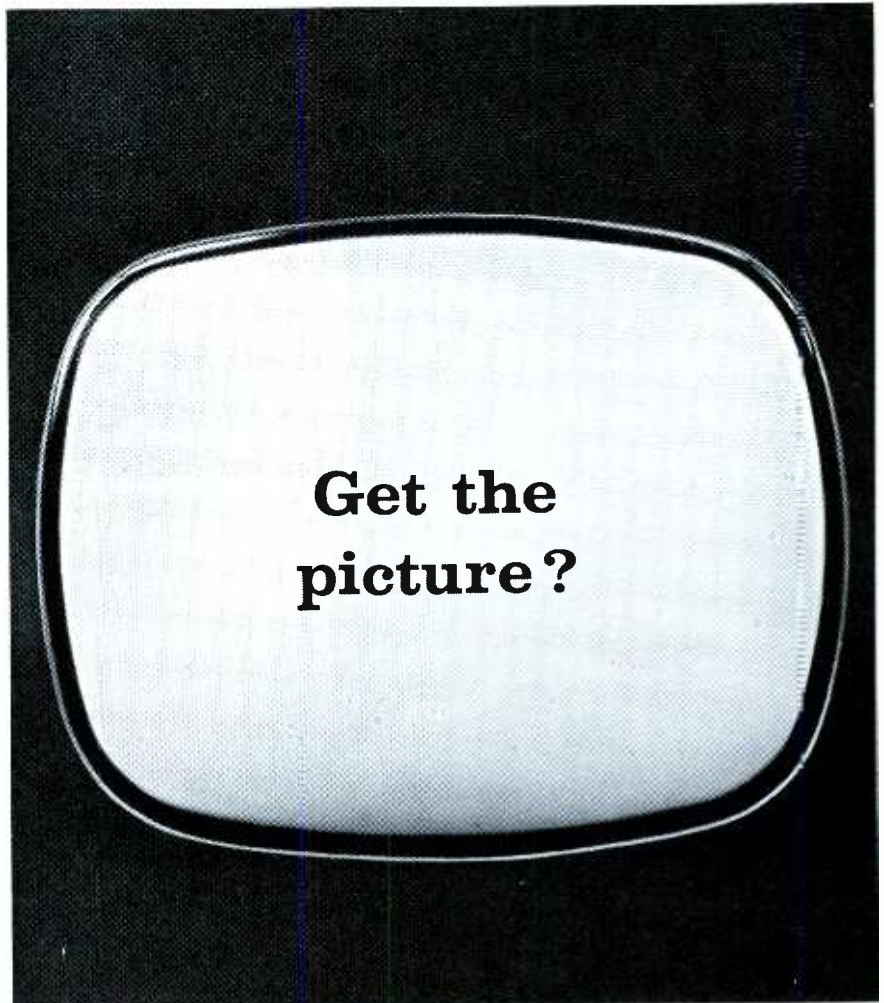

The new General Electric "DAYLITE-BLUE" picture tube* is designed, built, packaged to help you do a top-notch service job at the lowest operating cost. The new T-Box carton saves space in your shop and truck. Duds are easily repackaged for return . . . no tape or staples needed.

The tube is easy to install . . . no ion trap to adjust . . . fewer callbacks. And your customers are happy because of the high-quality picture.

But one of the most important features of G-E picture tubes is stocking and replacement. A single tube will replace as many as twenty other types . . . bent-gun or straight-gun. A selection of 25 G-E tubes will replace 250 other picture tube types. This means that you can now carry a minimum inventory for commonly replaced tubes. You can give customers faster service, simplify your ordering and avoid emergency pickups. G-E "DAYLITE-BLUE" picture tubes will save your time and help you make more money. Order from your G-E distributor today.

*All new parts and material in a reused envelope.

Progress Is Our Most Important Product

GENERAL  ELECTRIC

Circle 35 on literature card

Heavy Duty... Dual Heat



Professional, heavy-duty gun has two trigger positions—lets you switch instantly to the heat best suited for the job. Use of low heat prevents damage when soldering near heat-sensitive components and prolongs tip life. Heat comes on instantly when trigger is pulled—goes off when trigger is released. Spotlight illuminates work. Kit also includes break-proof metal-tone plastic utility case—smoothing tip—cutting tip—tip-changing wrench—and solder. MODEL D550PK.

brator or the power transformer, or both, worked at greater efficiency with an AC supply. A similar instance occurred when a customer brought in a dead set; the vibrator wouldn't start with DC power. The customer had just picked up the set from another shop where the vibrator worked perfectly, but only because the other shop worked with AC.

TV-FM Alignment

Aligning without proper equipment is the worst time-wasting "shortcut" in TV servicing. To top it off, this approach results in receiver performance far inferior to that which can be obtained with adequate equipment. The "experts" who claim to align with just a screwdriver or alignment tool should make a tour of factories where receivers are manufactured. They would find that all manufacturers have invested heavily in special signal generators and VTVM's. Certainly, if aligning required only hand tools, the set makers would be well aware of the fact, and they too would align without test equipment. This point can be stressed further: It would be much easier to train workers to align without equipment when only one receiver type or model is being produced. Therefore, if factory technicians need to use test instruments for a single model, it must be apparent that servicemen need generators even more, because many alignment jobs involve unfamiliar models.

These comments about TV receivers hold true as well for FM receivers. The IF bandpass obtained with a fixed-frequency generator, good though it might be (Fig. 6A) will rarely be as good as when done with a sweep generator and scope (Fig. 6B). The difference in fidelity obtained with each of these curves should be apparent to a "golden-ear" audiophile, although we "tin-eared" servicemen may fail to appreciate the higher quality.

AM Radio Alignment

Low sensitivity, poor selectivity and dial mistracking—the operating deficiencies caused by poor alignment—are far less obvious or objectionable in AM radios than in TV or FM receivers. Because of this, many service shops—even

Light...Efficient...Rugged



Weller® "Pencil" SOLDERING IRON

A low cost 25 watt, 115 volt iron that's ideal for miniature-type soldering. Use it as easily as a pencil. High efficiency and rapid recovery enable this Weller model to do the work of irons with much higher wattage ratings. Rugged heating element for extra durability and long service. Lightweight design reduces user fatigue, provides more accurate control. Complete with tip and cord set. Screwdriver-shaped tips available in three sizes. MODEL W-P.

Buy Weller Soldering Tools at your Electronic Parts Distributor
WELLER ELECTRIC CORP., 601 Stone's Crossing Rd., Easton, Pa.
Circle 36 on literature card

those who take pride in their TV or FM servicing—ignore alignment of AM radios, even in instances where the deficiencies are obvious. Often, when alignment is performed, it is done via the “shortcut” of using a radio station as a signal source and the serviceman’s ear as an indicator.

Not only does this form of trimmer-juggling take as much time as a proper alignment, but the results fall far short. Several technical factors are overlooked in this inadequate approach: First, the AVC system keeps changing sensitivity according to the amount of signal reaching the AVC diode, making it virtually impossible to actually peak the IF transformers. Secondly, when an IF transformer is being adjusted by this method, it will peak to the frequency of that stage which supplies the greatest amplification. Thus, the second transformer will probably peak to the frequency of the first, even though both stages are off frequency. Thirdly, using the ear as an indicator further reduces the probability of accurate peaking, because the ear is incapable of detecting very slight signal changes as trimmers are adjusted.

The proper way to obtain accurate IF peaking is to adjust for maximum AVC voltage as indicated by a VTVM on the AVC line. This method assures that the various trimmers need be adjusted only once—in stark contrast to the back-and-forth juggling necessary in “shortcut” aligning. Incidentally,

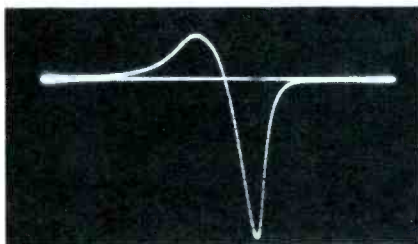

(A) Curve obtained by “shortcut”

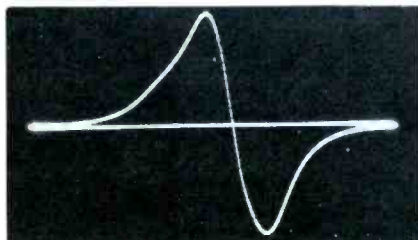

(B) Curve with proper alignment

Fig. 6. Proper FM detector alignment possible only with a sweep generator and oscilloscope.

when the IF’s are correctly peaked, receiver sensitivity and selectivity are optimum and dial tracking is invariably correct, except in those cases where either the oscillator-coil core or the tuning-gang plates have been tampered with. To summarize: Aligning with both a signal generator and a VTVM not only results in better performance, but can actually be done faster than so-called “shortcut” aligning.

Conclusion

This article, a discussion of servicing “shortcuts,” has offered hints

on alignment because many “shortcut” approaches save no time in the long run. The end result is usually no better than that which a poorly equipped “do-it-yourselfer” would turn out. The sensible approach to proper alignment is to avoid shortcuts.

Any so-called servicing shortcut should be viewed critically, almost as critically as the mountaineer eyed a visitor who asked about a shortcut to get over a certain mountain. “Out here,” responded the mountaineer, “shortcuts are strictly for the birds.” ▲

SAVE VALUABLE SERVICING TIME with the Model 1400 IN-CIRCUIT CAPACITOR TESTER

eliminates the time consuming method of unsoldering and resoldering when checking capacitors



NEW

EXCLUSIVE!
Special low test voltage of 2.9 volts provided to prevent damage to the new low voltage electrolytics used in transistorized equipment

\$29⁵⁰
Net

Slightly higher in the West

FEATURES

- New, modern rectangular tuning-eye indicator... extremely sensitive and accurate
- Large, easy-to-read dial for precision readings
- Line isolated power supply... no shock or short-circuited hazards
- Special storage compartment stores coaxial cable and line cord
- Handsome two-tone metal housing
- Fully guaranteed by standard EIA factory warranty

The new Model 1400 IN-CIRCUIT CAPACITOR TESTER cuts capacitor testing time by at least 75% and enables you to service more TV sets in less time. It operates with amazing ease. You just connect the test leads across the capacitor in-circuit you wish to test... set the range switch and the Model 1400 automatically indicates shorted or open capacitors. It will also check electrolytics, by-pass, coupling, blocking and filter capacitors, all without **disconnecting them from the circuit!** The valuable money-making time you save with the Model 1400 will pay for it over and over again.

SPECIFICATIONS

SHORTS TEST

Detects shorted capacitors of all types in-circuit with shunt resistance as low as 6 ohms.

OPEN TEST

Detects open capacitors for all values in-circuit down to 7 mmfd., with shunt resistance as low as 150 ohms.

VALUE TEST

Indicates value of electrolytics in-circuit from -2 mfd. to 450 mfd.

Available at your local parts distributor

Mercury ELECTRONICS CORPORATION

manufacturers of quality electronic products

111 Roosevelt Avenue, Mineola, New York

IN CANADA: R. C. Kahner Sales Ltd., 359 Enford Rd., Richmond Hill, Ontario

Circle 37 on literature card July, 1964/PF REPORTER 59



Product Report

For further information on any of the following items, circle the associated number on the Catalog & Literature Card.

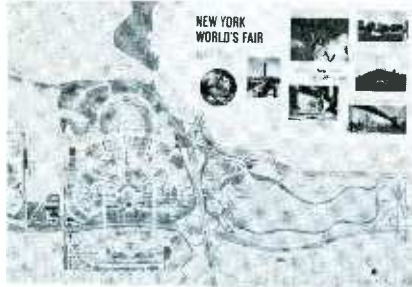

Free Map (122)

A Rand McNally World's Fair map in full color will be given as a free offer for Eveready flashlight and battery dealers by the Consumer Products Division of **Union Carbide Corp.** The map folds to pocket size and opens to 18" x 33". It shows all the exhibits and lists the major exhibitors with numbers that indicate their locations on the map. Parking areas, waterways, restaurants, available transportation, and lake amusement pavilions are also shown. The reverse side

of the map is a street guide to New York City; public buildings, transportation terminals, and sight-seeing attractions are listed. The map is being packed with the No. 65 Eveready Magnet Utility Lite offer and can be displayed on a pegboard or in bins. A counter display is included in suggested orders of photo, transistor, and alkaline batteries.



Two-Way Radio (123)

The "Porta-Mobil" two-way radio can be used as a plug-in mobile radio in an automobile, as an office base station, or as a portable unit. The transmitter sec-

tion of this **General Electric** transceiver provides 18 watts of RF output on low-band frequencies and 10 watts on high-band frequencies. All-solid-state circuits employ silicon transistors and other semiconductor components to improve reliability and operating performance. The transceiver measures 11" x 3 3/8" x 9 1/8". It can be operated from either 117 volts AC or 12 volts DC. A voltage-regulation circuit provides stable operation over wide changes in battery voltage. A 3" x 5" speaker is used, and an internal battery-saving audio switch may be adjusted to reduce audio output from 1.5 watts to 100 mw. Optional accessories include an under-dash mounting kit, a clip-on mobile antenna, a DC charging cable for 12-volt negative-ground operation, and a leather protective jacket.



Eliminate VTVM Battery (124)

The device shown above can be used to permanently replace the dry cell now used in VTVM's. "Lectrocell" is a miniaturized power supply the same size and shape as the cell it replaces: it connects



service faster with Fast-Fax

Raytheon Fast-Fax puts tube data for 600 types right at your fingertips. Stays up-to-date with "pop-in" supplements (including new types in '65 sets). Operates as an interchangeability guide and inventory control. See it at your Raytheon Distributor. You'll wonder how you ever got along without it. Fast-Fax. Only \$3.95.



SAVES
your back...

SAVES
your time...

47"

YEATS

SHORTY DOLLY
for RADIO and TV

just 47 inches high for STATION WAGONS
and PANEL PICK-UPS

FOLDING PLATFORM
15 1/4" x 24 1/2" top.
Snaps on or off.
(Platform only)
\$11.95

Designed for TV, radio and appliance men who make deliveries by station wagon or panel truck... the short 47 inch length saves detaching the set for loading into the "wagon" or pick up. Tough, yet featherlight aluminum alloy frame has padded felt front, fast (30 second) web strap ratchet fastener and two endless rubber belt step glides. New folding platform attachment, at left, saves your back handling large TV chassis or table models. Call your YEATS dealer or write direct today!

YEATS
Model No. 5
Height 47"
Weight 32 lbs.

"Everlast" COVER AND PADS

YEATS semi fitted covers are made of tough water repellent fabric with adjustable web straps and soft, scratchless white flannel liners. All shapes and sizes — Write

TV COVER

APPLIANCE DOLLY SALES COMPANY

1307 W. Fond du Lac Ave. • Milwaukee, Wisconsin
Circle 38 on literature card

to the AC power input of the VTVM. The unit, from **Lectrotech, Inc.**, is priced at \$3.95 and can be installed in a few minutes.



Palm-of-Hand Microphone (125)

This new microphone provides reduction of background noise at frequencies where intelligibility is most seriously affected. The Model 202 microphone has an internal ceramic cartridge inserted in its case. **Shure Brothers, Inc.** designed the case with carefully located apertures to provide clear, crisp, natural voice reproduction while providing discrimination against unwanted background noise. The unit is equipped with a nonlocking push-to-talk switch and fits in the palm of the hand.



RF Wattmeter (126)

This portable peak-reading wattmeter can be used for power measurements in pulsed RF systems (such as air navigational aids, telemetry, radar, television, etc.) and peak-envelope power measurements of single-sideband signals. The peak power of each pulse in a train of recurrent pulses can be read separately by adjusting the bias until that particular pulse has disappeared. The **Bird Electronic Corp.** Model 4310 can be used to measure peak power from 50 watts to 10 kw at frequencies between 2 and 1260 mc at pulse widths of .1 microsecond or greater. The unit is priced at \$149.00, elements at \$50.00 each, and the carrying case at \$10.00.

**EASY TO SELL... EASY TO USE... EASY TO MAINTAIN
2-WAY RADIO FOR THE BOOMING CB MARKET!**

Never before this performance breakthrough! Never before this big chance for you to cash in on the fast-growing 2-way radio market . . . for car, boat, home, business, office. The Courier 23 has unequalled performance with dollar for dollar value others can't match. It features dual conversion, transistor power supply, 23 crystal controlled channels and more features CB users want. It is priced at \$189.50 . . . and that includes all crystals, mounting brackets, power cords and noise-cancelling microphone. Best of all, the Courier 23 is "hot" . . . with wide acceptance everywhere!

CAN YOUR FIRM QUALIFY AS AN AUTHORIZED e.c.i. DEALER?

A sound knowledge of radio and/or communications equipment . . . the desire to install and service this equipment . . . an established business reputation and a good credit rating . . . a real interest in a dynamic new product with dramatic profits. These are the requirements. Write today for details!

e.c.i. electronics communications inc., Dep't P
325 no. macquisten pkwy, mt. vernon, n.y.

Please send full details on the Courier 23 and an e.c.i. dealership.

name

firm name

address

city zone state

THE WONDERFUL WIZARD 300*

1 ANTENNA + 2 WIZARDS = 2 OUTLETS
 1 ANTENNA + 3 WIZARDS = 3 OUTLETS
 1 ANTENNA + 4 WIZARDS = 4 OUTLETS
 1 ANTENNA + 5 WIZARDS = 5 OUTLETS
 1 ANTENNA + 6 WIZARDS = 6 OUTLETS
 1 ANTENNA + 7 WIZARDS = 7 OUTLETS
 1 ANTENNA + 8 WIZARDS = 8 OUTLETS
 1 ANTENNA + 9 WIZARDS = 9 OUTLETS
 1 ANTENNA + 10 WIZARDS = 10 OUTLETS
 1 ANTENNA + 11 WIZARDS = 11 OUTLETS
 1 ANTENNA + 12 WIZARDS = 12 OUTLETS
 1 ANTENNA + 13 WIZARDS = 13 OUTLETS
 1 ANTENNA + 14 WIZARDS = 14 OUTLETS
 1 ANTENNA + 15 WIZARDS = 15 OUTLETS
 1 ANTENNA + 16 WIZARDS = 16 OUTLETS
 1 ANTENNA + 17 WIZARDS = 17 OUTLETS
 1 ANTENNA + 18 WIZARDS = 18 OUTLETS
 1 ANTENNA + 19 WIZARDS = 19 OUTLETS
 1 ANTENNA + 20 WIZARDS = 20 OUTLETS
 1 ANTENNA + 21 WIZARDS = 21 OUTLETS

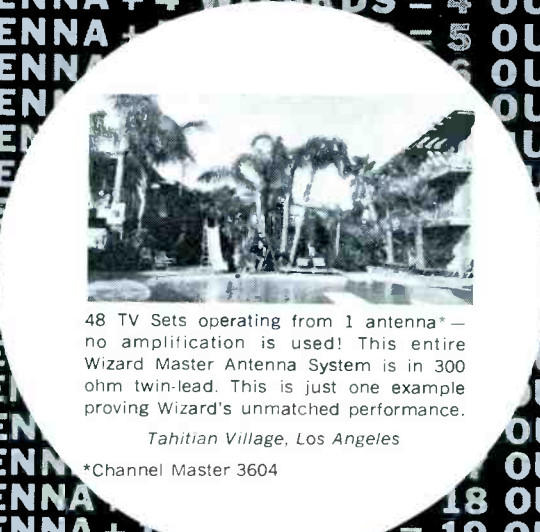

48 TV Sets operating from 1 antenna* — no amplification is used! This entire Wizard Master Antenna System is in 300 ohm twin-lead. This is just one example proving Wizard's unmatched performance.

Tahitian Village, Los Angeles

*Channel Master 3604

WRITE FOR SCHEMATIC DIAGRAM & SPECIFICATIONS
CHARLES ENGINEERING, INC.
 3421 NORTH KNOLL DR., LOS ANGELES, CALIF. 90028
 LIST \$1.95. OBTAINABLE AT YOUR DEALER OR WRITE.

*U. S. LETTERS PATENT NO. 2,913,679

Circle 40 on literature card



Radiotelephone for Pleasure Craft (127)

A new marine system, known as "Mari-com," provides all the communications requirements of most vessels. The system, manufactured by **Communications Co., Inc.**, consists of radio transmitters and receivers, inside a weatherproof cabinet, and a remote control unit. For long-range communications, a single-sideband compatible-AM unit operates on up to six channels in the marine band. A VHF-FM transmitter-receiver is installed for communications near the coast. The remote control unit is provided with two channel-selector switches, volume and squelch controls, and indicator lights.



Lightweight Antenna (128)

This easy-to-install antenna, for use with radio base stations operating on frequencies from 25 to 50 mc, is encased in fiberglass and weighs only 8 lb. It minimizes static and noise interference generated by charged dust particles and raindrops. According to **Motorola** engineers, the unit is capable of handling an RF output of 500 watts and provides a vertically polarized omnidirectional pattern. The antenna without whip stands 136" high and has a wind rating of 100 mph with a 1/2" coating of ice. It is priced at \$86.75 including the mounting brackets.

Get Your First Class Commercial F. C. C. LICENSE

QUICKLY!

Our business is electronics training. We are now in our fourteenth year of operation, and have trained thousands of electronics technicians for successful careers.

We specialize in preparation for F.C.C. license examinations. Learn how our training can prepare you quickly for your first class commercial F.C.C. license. Write or telephone us at any one of our teaching divisions listed below, and ask for "Catalog #41." It will be mailed to you free of charge.

There is no obligation on your part, and no salesman will call on you. Make your own decision—enroll if and when you wish.

Grantham School of Electronics

- 1505 N. Western Ave., Los Angeles, Calif. 90027
(Phone: HO 9-7878)
- 9320 Long Beach Bl., South Gate, Calif. 90280
(Phone: 564-3421)
- 12732 Garden Grove Bl., Garden Grove, Calif 92640
(Phone: 530-0795)
- 408 Marion Street, Seattle, Wash. 98104
(Phone: MA 2-7227)
- 3123 Gillham Road, Kansas City, Mo. 64109
(Phone: JE 1-6320)
- 821 19th Street, NW, Washington, D.C. 20006
(Phone: ST 3-3614)

Circle 41 on literature card

NEW PRICES from QUIETROLE



the oldest, most widely proved and sold radio and TV lubricant

- | | |
|---------------------------------|-------------|
| 2 oz. bottle with dropper | LIST \$1.49 |
| 4 oz. bottle | LIST 2.54 |
| 4 oz. bottle (brush-n-cap) | LIST 2.64 |
| 8 oz. bottle | LIST 5.07 |
| 6 oz. spray can — with extender | LIST 2.79 |
| 3 oz. spray can — with extender | LIST 1.79 |



Quietrole is your guarantee of the most effective, quick silencer of noisy radio and TV controls — the quality product that is a top value. Get Quietrole at quality jobbers. Some territories available for Experienced Representation.



Circle 42 on literature card



Frequency-Synthesized CB (129)

The Model FS-23 transceiver employs frequency synthesis to provide crystal control on 23 channels. Features of this **Sonar Radio Corp.** unit include a low-noise, dual-purpose transistor power sup-

ply, nuvistor receiver RF stage, and class-B push-pull modulator. Frequency accuracy, stability, and adjacent-channel and image rejection are excellent. The price of the FS-23, including microphone, power-supply cables, and mobile brackets, is \$299.95.



Transistor Radiotelephone (130)

This transistorized Citizens-band radiotelephone for short-range communications (1-20 miles) features a new squelch circuit that is unaffected by random noise. The **Pace Communications Corp.** Model 5000 operates with low battery drain and can be changed from a base-station or mobile unit to a portable unit by means of plug-in power jacks that adapt it to operate on 6, 12, 28, or 32 volts DC or 117 volts AC. Special test pins in the microphone connector are accessible from the front and permit checkout of all modules while the set is in operation. Snap-in modules, available through local distributors, are used in the transmitter, receiver, audio, control, and power-supply sections.



Base-Station Mike (131)

This 600-ohm base-station microphone is suitable for use with transistorized CB transceivers, including the Cadre and E. F. Johnson Messenger III. The Model 254D from **Turner Microphone Company, Inc.** can be used by all persons having transistorized sets but not base-station microphones. The 254D is supplied with a 7' cable and attached 91-MPM5L plug. Frequency response of the unit is 300-6000 cps. List price is \$36.50. ▲

Winegard

Dealer of the month

No. 21 of a Series

Red Covault Says: "With a Winegard Colortron C-44, we can pull in Chicago... over 150 miles away."



Winegard Salutes Otsego Television, Otsego, Michigan and their distributor, Electronic Supply Corporation, Battle Creek, Michigan.

Red Covault started out alone in Radio TV antenna servicing back in the Fall of 1951. After 13 years of hard work and exceptional customer service, he now has 3 full lines of TV sales, 2 full lines of appliances, 4 full time and 3 part time employees. With this growth, he has also become one of Michigan's largest Winegard dealers.

In his service area, which covers a 30 mile radius, Red spends most of his time making fringe and deep fringe home installations. "The Otsego area," he said, "gets a lot of wind storms, and Winegard antennas will not end up bent out of shape like most others."

This testimony of belief in Winegard construction and quality has shown in Red's outstanding sales record. He's one more important service man who knows Winegard Quality first hand.

Winegard Co.
ANTENNA SYSTEMS

D3009-G Kirkwood • Burlington, Iowa
Circle 43 on literature card

July, 1964/PF REPORTER 63

INDEX TO ADVERTISERS

ATR Electronics, Inc.	12
Aerovox Corp.	48
B & K Mfg. Co.	49
Div. of Dynascan Corp.	
Berns Mfg. Co., Inc., The	80
Blonder-Tongue Labs	44
Bussmann Mfg. Div.	20, 21
Castle TV Tuner Service	15
Charles Engineering, Inc.	62
Chemical Electronic Engineering, Inc.	80
Communications Co., Inc.	78
Deleo Radio Div.	71
EICO Electronic Instrument Co., Inc.	29
Electronics Communications Inc.	61
Finney Co.	13
GC Electronics Co.	38
General Electric	22, 23, 51, 53, 55, 57
Grantham Schools, Inc.	62
Heath Co.	75
Jackson Electrical Instrument Co.	52
Jensen Mfg. Co.	73
Jerrold Electronics	Cover 2
Kinematix, Inc.	75
L. A. Tuner Exchange	38
Littelfuse, Inc.	Cover 4
Mallory, P. R. & Co., Inc.	24
Mercury Electronics Corp.	59
Mosley Electronics, Inc.	50
Nortronics Co., Inc., The	46
Ohmite Mfg. Co.	12
Oxford Transducer Co.	40
Planet Sales Corp.	75
Precision Tuner Service	50
Quam-Nichols Co.	14
Quietrol Co.	62
RCA Electronic Components and Devices	Cover 3
RCA Sales Corp.	16, 17
Raytheon Co.	60
Sams, Howard W. & Co., Inc.	47, 74
Sarkes Tarzian, Inc. Semiconductor Div.	37
Tuner Service	9
Seco Electronics, Inc.	54
SENCORE, Inc.	39, 41, 43
Sonotone Corp.	77
Sprague Products Co.	10
Sylvania Electric Products, Inc.	45
Terado Corp.	80
Triplett Electrical Instrument Co.	56
Valley TV Tuner Service	80
Weller Electric Corp.	58
Wileo Co.	76
Winegard Co.	18, 19, 63
Yeats Appliance Dolly Sales Co., Inc.	60



FREE Catalog and Literature Service

*Check "Index to Advertisers" for further information from these companies.

Please allow 60 to 90 days for delivery.

ANTENNAS & ACCESSORIES

59. **ANTENNACRAFT**—Catalog sheet, illustrated in color, with information on connecting a UHF and a VHF antenna together using intercoupler G1483W.
60. **BLONDER-TONGUE**—Brochure describing boosters, couplers, antennas, and converters for improving VHF and UHF reception.*
61. **CLEAR BEAM**—Catalog listings for an additional line of indoor antennas.
62. **FINNEY**—Catalog No. 20-307 listing four newly announced multielement, single-boom, VHF-FM antennas.*
63. **JFD**—Literature and sales aids on log-periodic antennas. UHF-converter promotion kit. Literature on antenna amplifiers for VHF, UHF, and FM.
64. **MOSLEY ELECTRONICS**—Illustrated catalog giving specifications and features on large line of antennas for Citizens band, amateur, and TV applications.
65. **MULTITRON**—Booklet on outdoor and indoor all-transistor FM stereo electronic antenna.
66. **TRIO**—Brochure on installation and materials for improving UHF translator reception.
67. **WINEGARD**—Bulletin describing FM booster Model FM318 for monaural and stereo reception.*
68. **ZENITH**—Informative bulletin on new line of log-periodic vee-type antennas for FM, and monochrome and color TV.

AUDIO & HI-FI

69. **ASTATIC**—Catalog on microphones, phono cartridges, and needles; also cross-reference indexes for needles and cartridges.
70. **BENJAMIN**—Brochure on *Miracord* record changers and *Elac* phono cartridges.
71. **GIBBS SPECIAL PRODUCTS**—Folders describing principles of sound reverberation and *Stereo-Verb* reverberation units for automobiles.
72. **FIDELITONE**—Needle replacement catalog giving cross-reference to equipment manufacturers and needle manufacturers; includes photos of replacement needles.
73. **MERIT**—Bulletin on *Fiesta Lantern* speakers and accessories for multiple speaker operation.
74. **NUTONE**—Two full-color booklets illustrating built-in stereo music systems and intercom-radio systems. Includes specifications, installation ideas, and prices.
75. **OAKTRON**—"The Blueprint to Better Sound," an 8-page catalog of loudspeakers and baffles giving detailed specifications and list prices.
76. **OXFORD TRANSDUCER**—Product information bulletin describing complete line of loudspeakers for all types of sound applications; including replacements for public address and intercom systems.*
77. **PERMA-POWER**—Catalog sheet on *Ampli-Vox* Model S-500 sound column lectern, high-volume, battery-powered PA system.
78. **QUAM-NICHOLS**—New catalog listing replacement speakers for background music, public address, and hi-fi applications.*
79. **SONOTONE**—New audio-products catalog SAH-76, containing photos and specifications on phono needles, cartridges, microphones, and speakers.
80. **SWITCHCRAFT**—Product bulletin 140 describes new coiled cord assemblies with molded-on phone plugs and microphone connectors.
81. **UNIVERSITY**—Guide to stereo high fidelity, and catalog of speakers for PA applications.

82. **VIKING**—Specifications and prices on tape transport Model 96 and solenoid-operated cartridge handler Model 38.

COMMUNICATIONS

83. **PEARCE-SIMPSON**—Specification brochures on *Companion II* and *Escort* Citizens band transceivers.
84. **TURNER**—Brochure on line of microphones for base-station and mobile use; includes list prices.

COMPONENTS

85. **AMPROBE**—Full-line short-form catalog No. AAD-38 listing line of electronic components.
86. **BELDEN**—Catalog No. 864 showing complete line of electronic wire and cable products.
87. **BUSSMANN**—Bulletin SBCU on Buss Fustat Box Cover Units offers simple, low-cost way to protect workbench tools, soldering irons, drills, and the like against damage and burnout. Units fit standard outlet or switch boxes; have fuseholder, plus a plug-in receptacle, switch, and pilot light.*
88. **COLUMBIA WIRE**—Catalog No. 110 and supplement 110A showing line of wire and allied products for electronic applications.
89. **EVEREADY**—Battery data book containing over 500 pages on dry batteries; listing physical specifications, service-life data, and cross-reference information.
90. **GC ELECTRONICS**—24-page supplement No. FR-65-S listing newly introduced products.*
91. **GENERAL ELECTRIC**—Application-note abstracts showing available information on rectifiers; also flyer describing latest edition of SCR Manual.*
92. **ONEIDA**—Catalog on line of electronic components and replacement items.
93. **PERMACEL**—Bulletin describing line of plastic tape and plastic parts box.
94. **SPRAGUE**—Latest catalog C-615 with complete listings of all stock parts for TV and radio replacement use, as well as *Transfarad* and *Tel-Ohmike* capacitor analyzers.*
95. **TRIAD**—Brochure on newly introduced toroidal-wound power transformer TY-86, for use with battery-powered transistor inverters.
96. **WALDOM**—Catalog No. PMR-3 listing line of solderless terminals, tube sockets, and terminal strips.

SERVICE AIDS

97. **CASTLE**—How to get fast overhaul service on all makes and models of television tuners is described in leaflet. Shipping instructions, labels, and tags are also included.*
98. **PRECISION TUNER**—Literature supplying information on complete, low-cost repair and alignment services for any TV tuner.*
99. **YEATS**—The new "back-saving" appliance dolly Model 7 is featured in a four-page booklet describing feather-weight aluminum construction.*

SPECIAL EQUIPMENT

100. **ATR**—Descriptive literature on selling new, all-transistor *Karadio*, Model 707, having retail price of \$29.95. Other literature on complete line of DC-AC inverters for operating 117-volt PA systems and other electronics gear.*
101. **GREYHOUND**—The complete story of the speed, convenience, and special service provided by the Greyhound Package express method of shipping, with rates and routes.

102. **TERADO**—Bulletin on *Galaxy* Model 50-205 transistorized DC-AC power inverter.
103. **VOLKSWAGEN**—Large, 60-page illustrated booklet "The Owner's Viewpoint" describes how various VW trucks can be used to save time and money in business enterprises; including complete specifications on line of trucks.

TECHNICAL PUBLICATIONS

104. **CLEVELAND INSTITUTE OF ELECTRONICS**—"Pocket Electronics Data Guides" with handy conversion factors, formulas, tables, and color codes. Additional folder, "Choose Your Career in Electronics," describes home-study electronics training programs, including preparation for FCC-license exam.*
105. **RCA INSTITUTES**—64-page book "Your Career in Electronics" detailing home study courses in TV servicing, communications, automation, drafting, and computer programming; for beginners and experienced technicians.*
106. **HOWARD W. SAMS**—Literature describing popular and informative publications on radio and TV servicing, communications, audio, hi-fi, and industrial electronics; including special new 1964 catalog of technical books on every phase of electronics.*

TEST EQUIPMENT

107. **B & K**—Catalog AP-21R describing uses for and specifications of new Model 1074 Television Analyst, Model 1076 Television Analyst, Model 850 Color Generator, Model 960 Transistor Radio Analyst, new Model 445 CRT Testor-Rejuvenator, new Model 250 Substitution Master, Model 375 *Dynamatic* VTVM, Model 360V-*O-Matic* VOM, Models 700 and 600 *Dyna-Quik* Tube Testers, and Model 1070 *Dyna-Sweep* Circuit Analyzer.*
108. **EICO**—New 32-page, 1964 catalog of test instruments, hi-fi components, tape recorders. Citizens band, and amateur radio equipment.*
109. **HICKOK**—Complete description and specification information on newly introduced equipment—Model 662 installer's color generator; Model 580 portable tube tester; Model 727 multiplex generator; Model 235A portable field strength meter.
110. **JACKSON**—Complete catalog describing all types of electronic test equipment for servicing and other applications.*
111. **MERCURY**—Description and specification brochure on Model 900 Color TV Analyzer and Model 1400 in-circuit Capacitor Tester.*
112. **SECO**—8-page brochure giving specifications and prices for Models 88, 98, and 107B tube testers; also catalog on color bar generator.
113. **SENCORE**—Question-and-answer bulletin on new Model MX-129 *Multiplex Analyzer* and Model CR-128 Picture Tube Tester-Rejuvenator.*
114. **SIMPSON**—Latest series of VOM's are described in test-equipment bulletin; also information on line of automotive test equipment.

TOOLS

115. **ADEL**—Literature on "Nibbling Tool" that cuts, notches, and trims round or irregular holes to any size over 7/16"; ideal for radio chassis, templates, or shims.
116. **ARCO**—Bulletin on obtaining free *Vac-Vise* with order of dipped capacitors.
117. **BURNS**—Data on unique 3-in-1 picture tube repair tools, on *Audio Pin-Plug Crimper* that enables technician to make solderless plug and ground connections, and on new-style *ION* adjustable "beam bender" for CRT's.*
118. **ENTERPRISE DEVELOPMENT**—Time saving techniques in brochure from *Endeco* demonstrate improved desoldering and resoldering techniques for speeding up and simplifying operations on PC boards.
119. **LUXO LAMP**—Catalog on line of "touch-and-stay-put" lamps.
120. **WALLIN KNIGHT**—Folder on *Reflect-O-Scope*, an effective tool in static convergence of color TV receivers.

TUBES & SEMICONDUCTORS

121. **SEMITRONICS**—New updated 16" x 20" wall chart CH10 lists replacements and interchangeability for transistors and diodes.



PHOTOGRAPHY

REPORTER

SPECIAL

COMMUNICATIONS

SUPPLEMENT

Transistorized Mikes for Mobiles

by Norman D. Tanner
and Stuart N. Soll

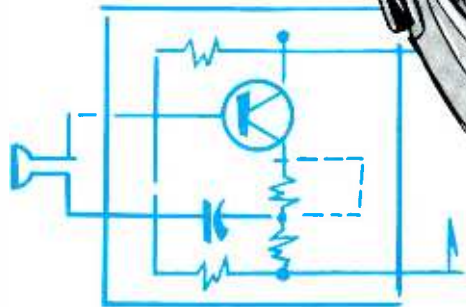

Special techniques make repairs simple.



The correct microphone to use with communications equipment is the one that provides maximum *intelligibility*. It has long been known that high fidelity is not necessary—in fact, not even desirable—for reproduction of the human voice. The mike that best satisfies this requirement is one that is “flat” in the range from about 300 to 3000 cps. Frequencies above and below this band are vitally needed in many audio applications but are undesired in communications—they wastefully absorb energy that could otherwise be used to increase microphone output.

For this reason, characteristics other than fidelity become important in narrowing the choice of a communications mike; for mobile use the selection becomes even more limited. Of the several *basic* types of microphones available, crystal, ceramic, dynamic, magnetic, and carbon types might be considered for mobile use; each has its own set of good and bad features. Let's

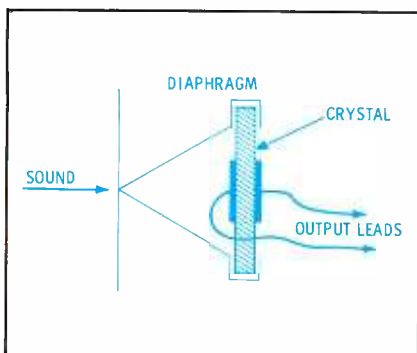

Fig. 1. Crystal slab needs no operating bias.

look at them to see how well each suits our purpose.

High-Impedance Types

Crystal and ceramic microphones—two high-impedance types—employ as the sensitive element a slab of nonmetallic material which under the influence of sound vibrations generates a voltage by piezoelectric effect. As indicated in Fig. 1, sound is transmitted to the element as a twisting motion, by a diaphragm.

Crystal microphones are low in cost, require no bias voltage, and have fairly high output levels (.03 volts is typical). However, crystal material, usually Rochelle salt, can't take high humidity or temperatures above 120°F. Since these conditions are inevitable in mobile installations during hot weather, uses for this mike are limited. (However it is probably used more than any other type at communications base stations.)

Ceramic microphones, which use a substance called *barium titanate* as the sensitive element, have almost all the advantages of the crystal type and are not affected by reasonable extremes of humidity or temperature. Although their cost is slightly higher and output level usually somewhat lower, ceramic microphones are very useful for mobile work.

Dynamic and Magnetic

The internal arrangement of a *dynamic* or *moving-coil* microphone

is detailed in Fig. 2. Construction is basically the same as that of a dynamic speaker, except that it is much smaller, and instead of a paper cone a small metal or plastic diaphragm is used. Dynamic microphones are extremely rugged. Most are low impedance—since a high-impedance version is harder to construct (or must use a matching transformer). The cost of a typical communications type is moderate. Output from a typical dynamic microphone used in communications is about .01 volts. Considering all pertinent factors, you can see this is another practical type for mobile use.

A relatively new microphone element configuration called the *balanced-armature, controlled-reluctance, variable-reluctance*, or sometimes just *magnetic*, is shown in Fig. 3. It may be most properly designated controlled (or variable) reluctance because, as you can see in the drawing, the reluctance of the magnetic circuit varies as the middle and only movable portion (armature) is vibrated between the pole pieces of the magnet. Sound vibrations move the diaphragm and drive pin back and forth, in turn moving the armature within the concentrated field of the powerful magnet.

This microphone can be made very rugged and compact. It is unaffected by normal extremes of environment and has an output at least as high as conventional dynamics. Another feature is most desirable: because of the mike's construction there is space for winding a coil with almost any desired wire size or number of turns—to provide any needed impedance with ease. Since none of its limitations are serious for mobile use, the controlled-reluctance microphone can also be considered for the job.

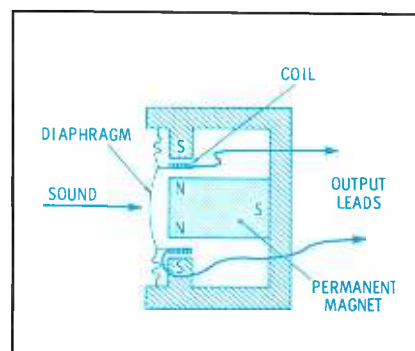

Fig. 2. Coil vibration induces audio voltage.

Variable Resistors

The last basic type we will discuss is the *carbon* microphone (Fig. 4). Certainly this is the most commonly used mike, since this type can be found in the "transmitting" end of every telephone. Carbon mike operation is based on the changing electrical resistance of a carbon-granule mass under varying mechanical pressure.

A small DC current (50 to 100 ma) is made to flow through carbon particles enclosed in an insulated container. When sound waves strike the diaphragm (which usually serves as one wall of the particle enclosure), mechanical exertion on the carbon is varied. The granular mass is alternately compressed and expanded causing corresponding variations in DC resistance. The resulting current variations show up as pulsating voltage developed across a load impedance in series with the microphone circuit (Fig. 5A).

Even though its impedance is very low, the voltage output of a carbon mike is so high that the signal can sometimes be applied directly to the high impedance grid circuit of a vacuum tube amplifier, as Fig. 5B illustrates.

Sometimes the tube current can be used as the microphone's external power source. In Fig. 5C, the mike has been connected directly in series with the voltage amplifier cathode. The DC component of the cathode current serves also as microphone current. As microphone resistance varies, a signal voltage develops between the cathode and grid (grounded) of the stage.

High output voltage is the most important advantage of the carbon microphone—often as great as 1 volt in mobile mikes, which are usually "close-talked." Sometimes

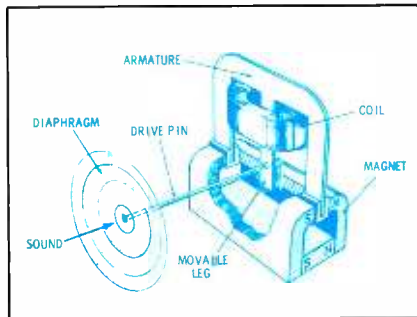

Fig. 3. Voice variations are transferred from diaphragm to drive pin, varying reluctance.

only a speech amplifier is needed to boost the voice signal, while in some very-low-power AM transmitters and in most FM transmitters the microphone audio voltage is applied directly to the modulator. Carbon microphones also have the advantages of ruggedness and low cost.

For mobile use, carbon microphones have only a few disadvantages: The need for an external current supply and the inherent high background "hiss" (resulting from random changes in the resistance among the carbon particles) are two noticeable ones. Another disadvantage is *granule packing*, which can happen gradually through aging or suddenly from a sharp impact or strong sound wave. The result is weaker output; since varying degrees of granule packing often occur during use, sensitivity constantly changes. In spite of these objections, the carbon microphone is used in a great number of mobile installations.

Now Add An Amplifier

By comparing the various microphone types we see that all the desired characteristics are available—if we could just shuffle them around a bit. What we need is the high output voltage of the carbon mike combined with the ruggedness, freedom from "hiss," and uniform sensitivity of the dynamics.

The above desirable characteristics have been combined recently by *transistorizing* moving coil and controlled-reluctance microphones. While the transistor amplifiers are generally contained within the mike case, one manufacturer has built a transistor preamp into the *terminal plug* of a high-performance telephone headset. Preamplification at the signal source increases the signal-to-noise ratio by boosting amplitude before the audio becomes subject to stray electric or magnetic fields.

Transistorized microphones are designed to be directly interchangeable replacements for carbon types. The preamplifier gets its operating power from the original carbon mike current supply. In some mobile units there is nothing to do but plug in the new microphone, while in others there are minor adjustments or a few simple circuit changes to be made (modification instructions are usually packed with the new microphone).

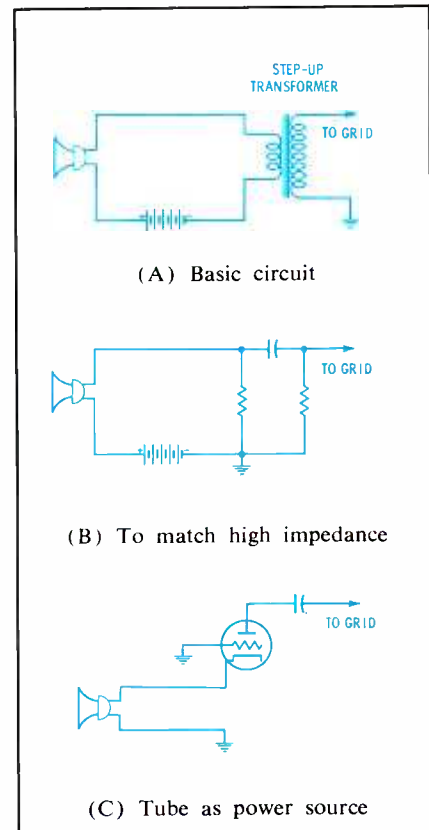

Fig. 5. Typical input circuits for carbon mics.

These transistorized microphones work into circuits similar to those shown in Fig. 5, the primary difference being lower power consumption. The amplified units will draw only about 2 to 20 ma (about 10% of that drawn by carbons). Because of this great difference in current, most conversions will call for a re-adjustment by means of the mike current control or by minor circuit changes within the transmitter. Wide voltage ranges can safely be tolerated, with accompanying variations in amplifier gain.

Transistorized microphones normally have outputs at least as high as carbons (around 1 to 4 volts), derived from amplifier gains as low as 30 in some simple circuits to several hundred in the more complex

• Please turn to Page 78

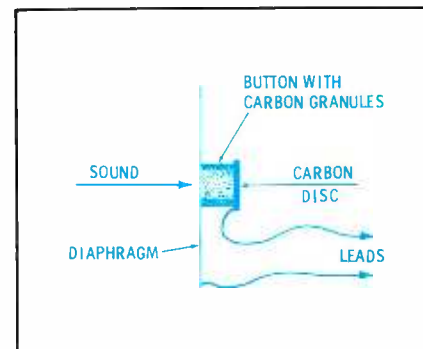

Fig. 4. Carbon microphone has a high output.

removing
the

MYSTERY

FROM MODULATORS

by Edward M. Noll

here's how the common FM types work.

components must all make their appropriate contributions to the modulating signal. Thus the combination of maximum-range and minimum-interference requirements imposes rather strict requirements on the design and adjustment of the modulator section of the transmitter.

Modulation Considerations

Four distinct steps are involved in preparing the signal for application to the phase modulator. These involve a pre-emphasis network, a modulation clipper, an integrator, and a low-pass audio filter. To better understand the need for these operations, let us first consider the difference between frequency and phase modulation.

change in a short period of time, and there must be a greater rate of frequency change (deviation) to attain a given phase shift.

A PM system can be made to produce a true FM signal by inserting a so-called *predistorter* in the audio system. Such a distorter attenuates the audio signal at a rate of 6 db per octave so that a high-frequency audio signal reaches the modulator at a lower relative amplitude than a low-frequency signal. Therefore the maximum phase shift is less, and a decrease in the maximum deviation results. In effect, the maximum phase shift is made to decline with frequency.

Preventing Overmodulation

Still another factor must be considered in the modulation system of a two-way radio transmitter: overmodulation must be automatically prevented. As a result, it is necessary to employ a modulation clipper to limit audio peaks at a level that prevents overmodulation.

It might at first seem feasible to limit the maximum amplitude of the highest audio frequency (3000 cps) to a value that would prevent overmodulation. Thus no 3000-cps component would be permitted to rise above an amplitude level that would produce a phase deviation of 1.67 radians (5 kc/3 kc). This technique is not advisable because it results in clipping of the lower-frequency components at the same amplitude level as the high-frequency components. In a PM process this means that clipping occurs before the lower-frequency audio has risen to the level that produces maximum permissible deviation. As a result, the important voice-frequency energy between 300 and 1000 cps is sharply reduced. It is apparent that if a modulation clipper is to be used wisely, there must be some pre-emphasis of the audio-frequency range in the modulation system. The technique used is often referred to as *instantaneous deviation limiting*.

In Fig. 1, the pre-emphasis network precedes the modulation clipper-limiter. For a given microphone-input level the network raises

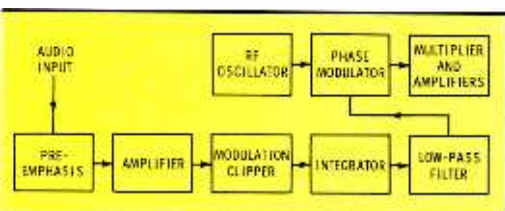

Fig. 1. Block diagram of a phase-modulation system of the type used in two-way FM radio.

One hundred percent modulation in an FM two-way radio transmitter corresponds to a deviation of ± 5 kc. Phase modulation is a simple method of obtaining that deviation, although excessive carrier swing must be avoided to keep distortion products to a minimum. A multiplier chain with a count of 12-to-1 or higher is used to build up the center frequency and the deviation to the final transmitted values. When a count of 12 is used, the phase modulator need produce a deviation of only about 400 cps (5 kc/12).

If interference is to be minimized, modulation splatter (the generation of spurious sideband components in adjacent channels) must be avoided. At the same time, the attainment of maximum range and reliability requires that the transmitter be fully modulated. The voice-frequency

Types of Modulation

In an FM system, the maximum frequency deviation of the modulated oscillator depends only on the peak amplitude of the modulating audio signal; the deviation is the same regardless of frequency. The modulation index therefore declines with an increase in the modulating frequency in a manner such that a constant frequency deviation is maintained for a given audio amplitude:

$$\text{deviation} = \text{modulation index} \times \text{audio frequency}$$

In a PM system, the modulation index remains fixed regardless of the modulating frequency. The above relationship shows that a higher modulating frequency develops a greater frequency deviation and therefore requires a greater bandwidth. This should seem reasonable if you consider that a higher modulating frequency involves a fast

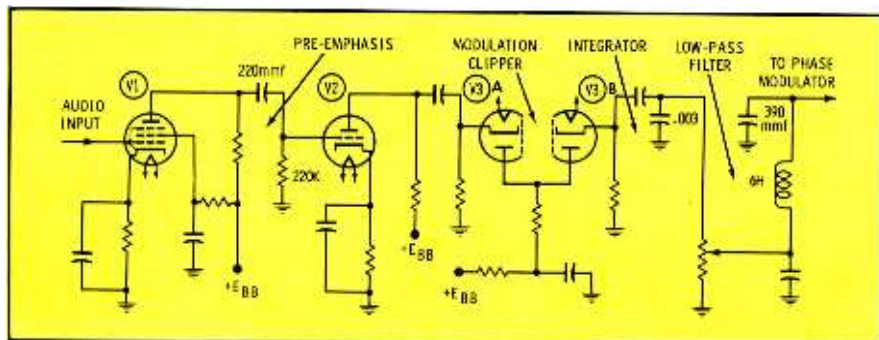

Fig. 2. A typical tube circuit for preparation of audio signal for the phase modulator.

the amplitude of the higher frequency components with respect to the middle- and lower-frequency components. As a result, the higher-frequency components are clipped at an earlier amplitude level than the lower-frequency components (relative to their initial amplitudes).

In normal operation, substantial clipping occurs at the higher frequencies of the voice spectrum. However, for high sound levels the clipping action extends down into the lower audio frequencies as well.

Other Interference Sources

The function of the modulation limiter is to prevent overmodulation and the generation of sideband components that fall into adjacent channels. However, in the actual clipping process, harmonics of the modulating signal can be generated, and these frequency components may well fall into the adjacent channels. To prevent this possibility, a simple RC integrator is often added after the modulation limiter. Its purpose is to attenuate any high-frequency harmonics that may be generated in the clipping process.

A low-pass filter follows the modulation-limiting system. Its purpose is to attenuate frequency components above 3000 cps. It has an important function in preventing adjacent-channel splatter because the higher modulating frequencies contribute to a greater resultant bandwidth of the generated FM signal. Sometimes a secondary function of the low-pass filter is to act as a predistorter.

Typical Audio Circuit

A typical circuit arrangement is shown in Fig. 2. The voice-frequency components are supplied through a pre-emphasis RC combination to the triode audio amplifier stage (V2). Note that the capacitor has a low value of capacitance. Therefore, the high frequency components are not attenuated, but the RC combination displays an increasing attenuation as the audio frequency decreases. The output of the amplifier is applied to a diode modulation clipper. The two diodes are forward biased and conduct continuously, except when a modulation component exceeds an established positive or negative peak value. The input diode clips positive peaks; the output diode, negative peaks.

An RC integrator is located in the output circuit of the modulation clipper. It removes clipping transients, and its deemphasis characteristic equalizes the frequency response.

The low-pass filter attenuates frequency components above 3000 cps. It also controls frequency response over the desired range to obtain the most favorable overall response for the phase-modulation process.

The Phase Modulator

It has been mentioned that in two-way radio the maximum permissible deviation is so low that a simple phase modulator can be employed. The arrangement shown in Fig. 3 is by far the most common type used in two-way radio transmitters. Note that the RF oscillator voltage (E_p) is transferred to the output of the modulator through two paths. One path is by way of capacitor C2 directly to the output circuit. A second path is by way of capacitor C1 to the control grid of the phase modulator. In the latter case, the RF signal reaches the output through the tube. In effect, a part of the modulator output voltage (E_o) is supplied directly from the oscillator as voltage E1, while a second signal (E2) is a result of plate-current variations in the phase-modulator circuit. These two signal components are not in phase, and as a result the net voltage (Eo) can be made to vary in phase by changing the amplitude of either E1 or E2. In this phase modulator, it is the amplitude of E2 that is changed by the modulating audio signal.

It might appear that E1 and E2 would be exactly 180° out of phase. However, the values of C1, C2, and the output inductor are such that the phase shift is less than 180°, as shown in the vector diagram. One might also assume that the amplitude of the E2 component would be much greater than that of E1 because of amplification by the phase modulator. However, this is not the case, because proper selection of operating voltages and/or some cathode degeneration keep the two components at comparable levels.

The RF signal (E1) fed directly to the output is of constant amplitude. The RF signal component (Eg), applied directly to the control

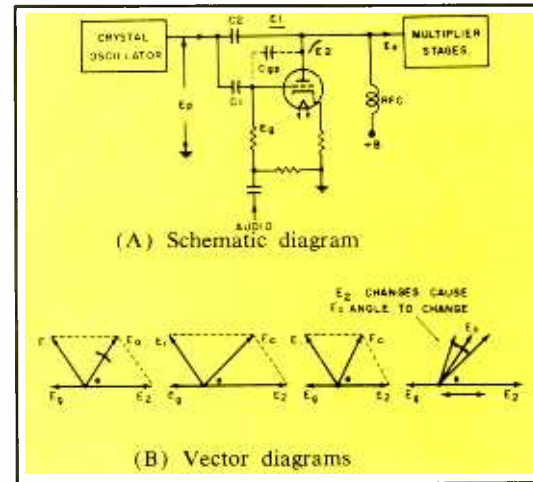

Fig. 3. A common phase-modulator circuit.

grid, is also constant in amplitude. The modulating wave is applied to the same grid and varies the transconductance of the tube at the audio rate. In this case transconductance can be expressed as follows:

$$G_m = \frac{I_p}{E_g}$$

Although E_g remains constant in amplitude, the changing transconductance causes a varying RF plate current. As a result, the RF plate-voltage (E_2) varies in amplitude with the modulating wave. What is more important, this change in amplitude produces a net output voltage that varies in phase with respect to the no-modulation phase of the phase-modulator output. By proper control of frequency response in stages ahead of the modulator, as covered in previous paragraphs, an output deviation can be obtained that is comparable to that from direct frequency modulation.

It should be noted that the amplitude of the resultant also varies somewhat with modulation. By proper choice of operating conditions, the effects of this change in amplitude can be minimized. The amplitude variations that do occur

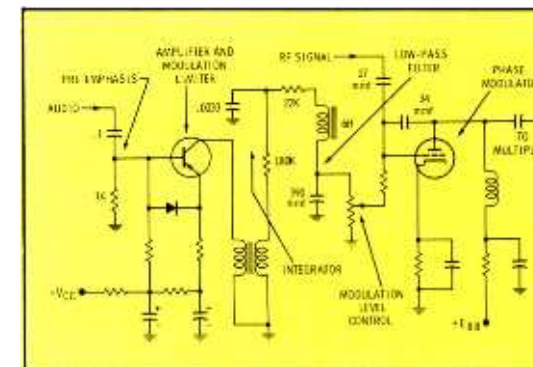

Fig. 4. Schematic diagram of a transistor audio system driving a tube-type modulator.

are further limited by the succeeding class-C multipliers and amplifiers.

Transistor Speech Amplifier

Fig. 4 shows an example of a transistor amplifier and modulation limiter used with a tube-type phase modulator. Since the amplifier has only one stage, it is necessary to use a microphone with a built-in transistor amplifier or a microphone with a high-level output. The input circuit provides pre-emphasis of 6 db per octave.

The common-emitter transistor stage is highly stabilized. It amplifies and provides positive and negative peak clipping. Critical stabilization of the operating point insures a symmetrical clipping capability.

The audio-output transformer, and an integrator placed across its secondary, remove transients and equalize the frequency-response characteristics. The signal then passes through the low-pass filter to the modulation-level control. This control is often referred to as the *instantaneous deviation control* because it sets the voice-frequency amplitude at a level which will prevent deviation in excess of ± 5 kc. The phase modulator is a tube type similar to that of Fig. 3.

All-Transistor Phase Modulator

The phase modulator shown in Fig. 5 uses a three-transistor audio section. The input stage is a common-emitter type with the pre-emphasis network in the emitter circuit. Due to this network, there is greater feedback at the lower frequencies, and pre-emphasis of the high frequencies results. The collec-

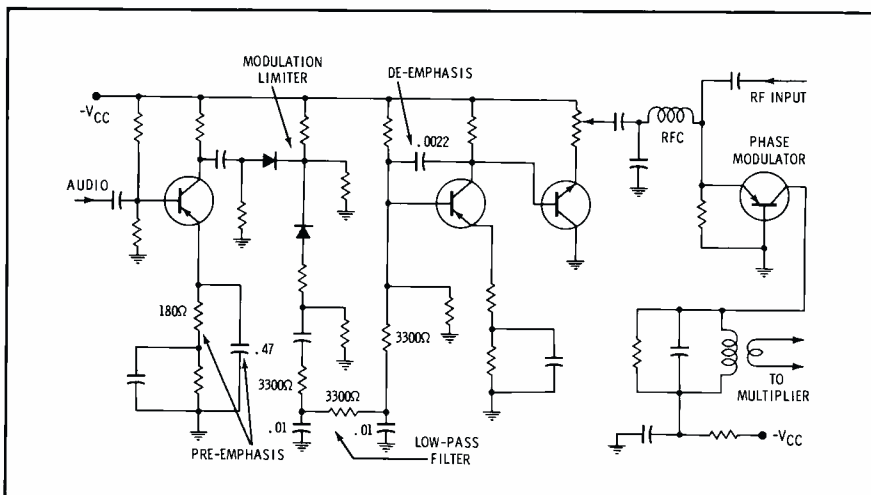

Fig. 5. Schematic diagram of an all-transistor speech-amplifier system and phase modulator.

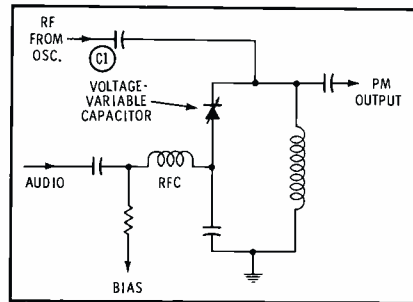

Fig. 6. Phase modulation is accomplished by voltage-variable capacitor in this modulator.

tor output is applied to two forward-biased semiconductor diodes that operate as positive and negative peak-modulation clippers.

A two-section RC filter follows the modulation clipper. Its low-pass characteristic rejects audio components above 3000 cps. De-emphasis is provided by the feedback link of the second common-emitter audio stage. Again frequency-selective feedback is used. In this case the feedback increases with increasing frequency and compensates for the frequency response of the input stage.

A common-collector driver stage follows the second audio stage; the modulation control is in its emitter circuit. Through a suitable RF filter, the voice frequencies are applied to the transistor modulator, which is connected in a common-base configuration.

The phase of the collector output voltage relative to the no-modulation value is determined by the transistor operating point. The initial operating point depends on the emitter current and collector voltage. This point is chosen, with no modulation applied, by setting the proper magnitude of RF drive. The modulating voltage varies the operating point

and causes transistor capacitance changes. As a result, the output voltage is moved in phase from the no-modulation value.

Semiconductor-Junction Modulator

One of the effects of a changing voltage across a semiconductor diode is a change in the capacitance of the diode. By suitable semiconductor design, this change in capacitance can be emphasized and made to vary in a suitable manner. This type of device is called a *voltage-variable capacitor*, and it can be made to operate as an effective voltage-to-frequency converter.

It is probable that voltage-variable capacitors and other types of semiconductor diodes will be used extensively in the future as both frequency and phase modulators. They are already being used in radio-telemetry FM transmitters and portable two-way radio gear.

The phase modulator in Fig. 6 uses a voltage-variable capacitor diode. The diode is placed across a part of an output resonant circuit. Such a resonant circuit can be connected almost directly across the output tank of an RF oscillator. If the capacitance of C1 is properly chosen, any change in the capacitance of the diode will not affect the frequency of the oscillator. It will, however, affect the frequency of the resonant circuit.

The modulating waveform changes the potential across the voltage-variable diode. Consequently, there is a corresponding change in the diode capacitance and in the resonant frequency of the tuned circuit. The result is a change in phase angle of the oscillator voltage across the resonant tank circuit because the resonant-circuit impedance now has a reactive component at the oscillator frequency. Thus, a phase-modulated output is produced. An appropriate filter arrangement and DC bias are provided to establish the most favorable operating point for the voltage-variable capacitor.

Delay Line

The delay-line modulator is shown in Fig. 7. In this type of modulator the RF wave from the oscillator, arriving via a buffer amplifier, is sent along a delay line. Its time of travel along the line depends on the

• Please turn to Page 80

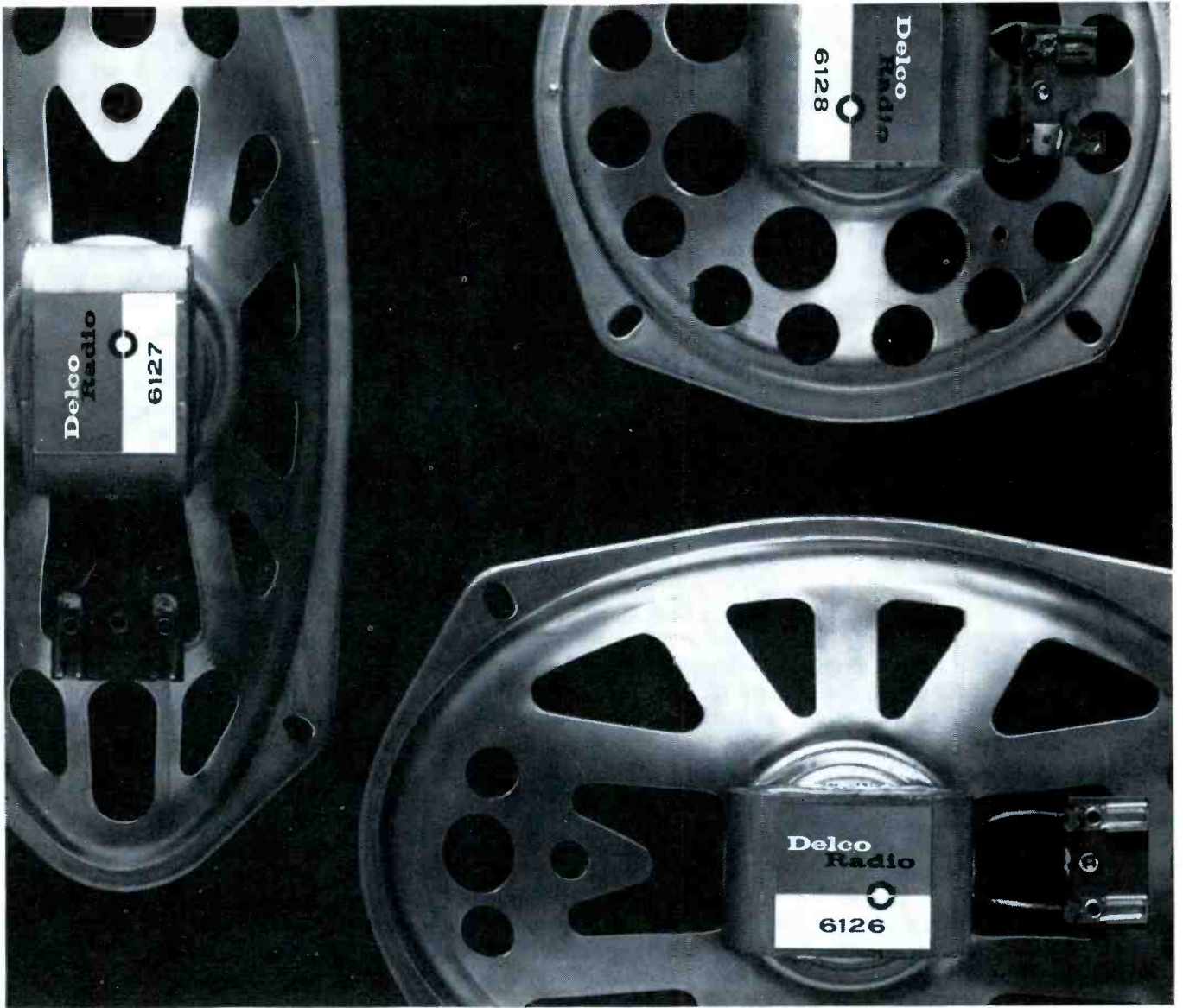

3 SPEAKERS REPLACE 23

These three Delco Radio 8-10-ohm replacement speakers permit you to cut your speaker inventory. They replace most units in current General Motors cars and many competitive makes. They install easily and quickly, take a "tip jack," "blade," or solder connection. Excellent for home hi-fi and TV sets, too! Speak up for the latest in replacement speakers. Call your United Delco supplier today.

Delco Radio Automotive Radio Service Parts and Electro-Mechanical Devices are distributed nationally through **United Delco**

THREE SPEAKERS, ALL WITH SLOTTED MOUNTING HOLES

Number	Size	Magnet Wt.	Mounting
6126	6 x 9"	1.6 oz.	front/rear
6127	4 x 10"	1.6 oz.	front/rear
6128	6" round	2.5 oz.	rear-seat

simply say **Delco**

DELCO RADIO, Division of General Motors, Kokomo, Indiana

Circle 44 on literature card



RADIO PAGING



by Leo G. Sands

A surprising fact to many service technicians is that radio paging outdates two-way mobile radio. Early police radio systems consisted of a base station and mobile receivers installed in squad cars. These systems operated at frequencies just above the broadcast band and employed AM. Bulletins were broadcast to all police cars; when two-way contact with a specific officer was required, his name or car number was announced on the air. The officer then went to the nearest telephone booth or call box and checked in with headquarters.

A similar technique is used today to contact subscribers to various radio paging services. Each subscriber is furnished a pocket radio receiver. At frequent intervals, the subscriber holds the receiver to his ear and presses the "listen" button to hear broadcasts from the base station. If he hears his name or code number called, the subscriber goes to the nearest available telephone and calls the operator at the paging service base station to receive his message. This kind of paging service is available in most large cities.

Radio paging service companies frequently operate in conjunction with a telephone answering service. When a subscriber does not answer his telephone, or when his office wants to reach him, he is paged by radio. His name or code number is

broadcast at regular intervals, along with the name or code number of others who are being paged, until he checks in by telephone.

These systems operate in the 25-50 mc band; they generally employ AM instead of FM, because of the lower cost of AM pocket receivers. Base station transmitters vary in power output to as high as 250 watts. Paging calls can be broadcast manually by an operator, or recorded and played back from tape. Names or code numbers are erased when that subscriber checks in.

Pocket paging receivers of this type are usually simple devices that employ a superregenerative detector, an audio stage, and a built-in miniature speaker which can be held close to the ear. The antenna is usually a limp piece of insulated wire about a foot long. An RF amplifier is not required for isolation since the antenna system is a very inefficient radiator of the RF hash generated by the superregenerative receiver. To conserve battery life, the receiver is alive only when the press-to-listen switch is operated.

Paging systems such as these, rendering public communications service, are licensed as miscellaneous common carriers under Part 21, FCC Rules and Regulations. Similar systems, licensed in the Citizens-band or other mobile radio service, can also be operated for private purposes, such as to page employees and executives within a plant area. When a paging transmitter is operated at low power, under Part 15 of FCC Rules and Regulations, a license is not required.

Larger, more sensitive and selective receivers can be installed in vehicles or at fixed locations. All paging calls are heard as they are broadcast. When a person hears his name or code number, he checks in by telephone or other prearranged means; some messages require no response. Either AM or FM receivers are used, depending upon the type of base station transmitter. Receivers are usually superheterodyne types, crystal controlled to the assigned frequency.

Radio paging range depends upon the frequency band, base station power and antenna system, and the type of receiver used. For example, broadcasts from one station in Man-

hattan can easily be picked up by simple superregenerative (AM) pocket receivers in New Jersey, more than 15 miles away. In a few localities, paging range may exceed 50 miles. Range is considerably greater when a sensitive mobile or fixed superheterodyne receiver is used.

More sophisticated pocket receivers employ superheterodyne circuits with crystal control. They are somewhat larger and heavier than the superregenerative types, but have greater range and are less subject to interference from nearby systems.

Radio paging is widely used by Civil Defense organizations and auxiliary public safety groups to alert members at home or in their cars. Receivers of the type shown in Fig. 1 are generally used. This particular receiver is a dual-conversion FM set, with a crystal lattice filter to enhance selectivity. Its frequency is fixed-tuned by a crystal to that of the base station. Such receivers are available from several manufacturers in both low-band (25-54 mc) and high-band (147-174 mc) types.

Some monitor receivers are tunable through an entire band, or both high and low bands, and the dial must be carefully tuned to the desired frequency. They are not as satisfactory as crystal-controlled units for monitoring a specific frequency on a continuous basis, because of the inherent drift of most self-excited local oscillators. They do, however, permit reception on any frequency within their tuning range.

The receiver shown in Fig. 1 is available in single and multichannel types. To change the frequency of the single-channel type, it is necessary to replace the crystal. Multichannel types are equipped with a front-panel switch to select as many as six crystal-controlled frequencies.



Fig. 1. Fixed radio paging receiver equipped with tone decoder of type shown in Fig. 4.

...for servicing and upgrading hi-fi and stereo phonograph, radio and television sets

Here's the **NEW** Jensen **Concert Hi-Fi Replacement Series**

Everything we have learned from years of engineering the world famous JENSEN High Fidelity loudspeakers . . . all of our design and production experience as suppliers of superior hi-fi speaker systems to makers of fine home entertainment equipment . . . all of this know-how has been brought to the new Jensen Hi-Fi Replacement Series.

This series offers for the first time full-range, woofer, midrange and tweeter units in sizes and types that simplify the service problem; many are available nowhere else.

It will pay to concentrate on Jensen, the most experienced producer of high fidelity loudspeakers. And the customers will be pleased, too.

Get the full story—send for Catalog 1090 today.

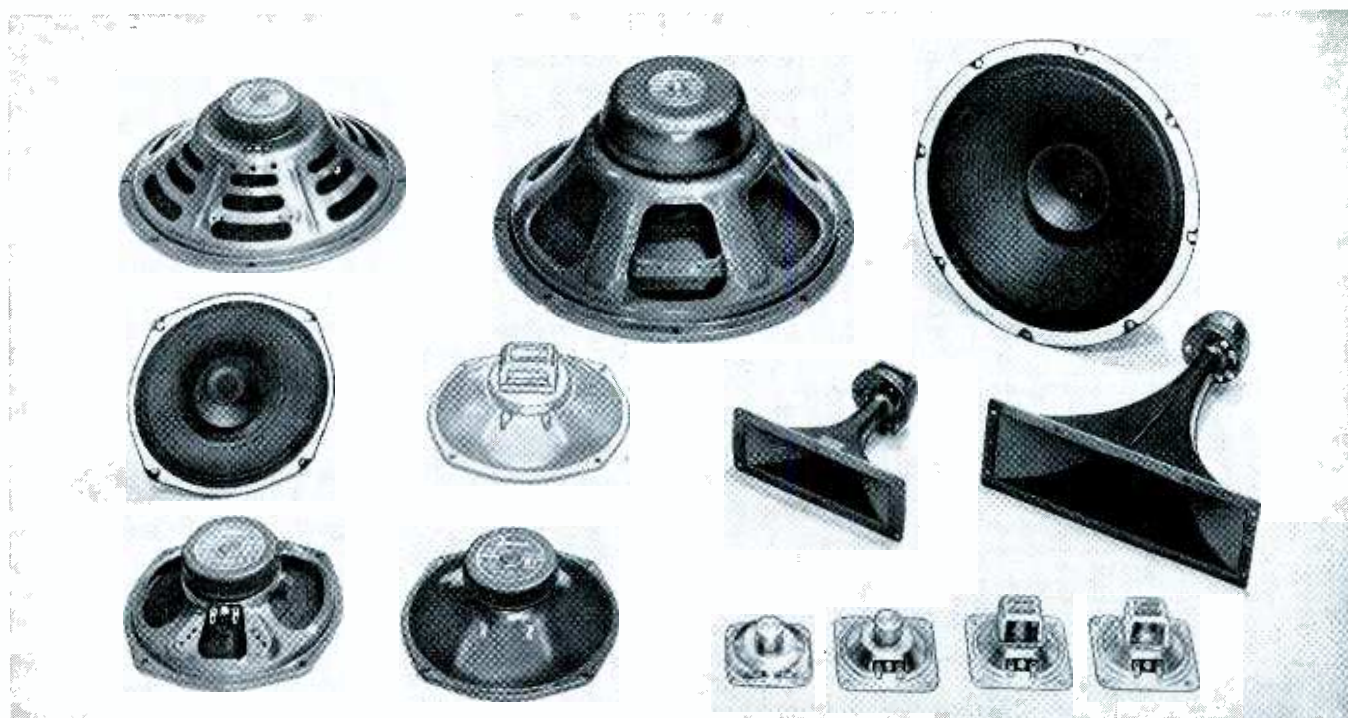

MODEL NO.	TYPE	SIZE	FREQUENCY RANGE	IMPED. OHMS	POWER RATING†	LIST PRICE
D-8R8	Full Range, Dual Cone	8"	50-14,000	8	12	\$14.65
D-12R8	Full Range, Dual Cone	12"	40-13,000	8	14	18.25
W-8R8	Woofer	8"	45-2,000	8	20	13.65
W-12R8	Woofer	12"	35-2,000	8	25	17.75
W-15N8	Woofer	15"	30-2,000	8	30	56.25
M-8U8	Midrange, Closed-Back	8"	600-4,000	8	25	7.65
M-8R8	Midrange, Closed-Back	8"	600-4,000	8	30	14.00
T-3K78	Direct Radiator Tweeter	3"	2,000-15,000	8	15	4.95
T-35K78	Direct Radiator Tweeter	3½"	2,000-15,000	8	15	5.25
T-35W8	Direct Radiator Tweeter	3½"	2,000-15,000	8	15	5.50
T-35V8	Direct Radiator Tweeter	3½"	2,000-15,000	8	15	5.95
T-107	Compression Horn Tweeter	—	2,000-16,000	8	25	16.50
T-109	Compression Horn Tweeter	—	1,000-16,000	8	25	18.50

†Program rating. Peak power is twice the indicated figures.



JENSEN MANUFACTURING COMPANY / DIVISION OF THE MUTER COMPANY / 6601 SOUTH LARAMIE AVENUE, CHICAGO 38, ILLINOIS
Canada: Radio Speakers of Canada, Ltd., Toronto • Argentina: Ucoa Radio, S. A., Buenos Aires • Mexico: Fapartel, S. A., Naucalpan, Mex.
Circle 45 on literature card

SAMS Best Sellers

LATEST EDITIONS OF TWO FAMOUS HOWARD W. SAMS HANDBOOKS!



Tube Substitution Handbook
still the Leading Reference—lists 10,000 Tube Substitutions Absolutely indispensable! 7 Sections cover: Cross-reference of American Receiving Tubes; Cross-reference of Subminiature Tubes; Industrial Substitutes for Receiving Tubes; Communications and Special-Purpose Tubes; Foreign Substitutes for American Types; American Substitutes for Foreign Types; Picture Tube Substitutions. 128 pages; 5 1/2 x 8 1/2". **\$150**
Order TUB-7, still only.....



Transistor Substitution Handbook
Computer-Selected Substitutes for Over 5,000 Transistors—Updated! Lists over 40,000 direct substitutions, including all popular types used in transistor radios and similar equipment. Shows biasing diagrams, polarity identification and manufacturers for over 5,000 types. Special section lists more than 15,000 American replacements for foreign transistors—plus a semiconductor and diode guide containing 800 substitutions. 128 pages, 5 1/2 x 8 1/2". **\$150**
Order SSH-5, still only.....

Transistor Ignition Systems Handbook

by Brice Ward. Transistor ignition systems are revolutionizing the auto industry. This new book clearly explains the principles of these highly efficient systems—how they work, how to install them, how to tune them up. Describes typical systems now in use; provides complete data on installation. 128 pages; 5 1/2 x 8 1/2". Order IGS-1, only..... **\$250**

Color TV Servicing Made Easy

by Wayne Lemons. Written in "make easy" style. Takes the mystery out of color TV servicing. Introduces you to color principles and setup adjustments; thoroughly covers color circuitry, adjustments, and servicing of all color TV sets produced to date. This book will help to put you into this fast-growing, profitable service work. 128 pages, 5 1/2 x 8 1/2". **\$295**
Order CSL-1, only.....

PHOTOFACT Guide to TV Troubles

by Herrington & Oliphant. Contains over 240 photos of actual TV picture troubles, keyed to defective components in typical circuits. Shows exactly what happens to picture tube display when any component becomes defective. By making the quick checks recommended in special charts, troubleshooting is reduced to minutes. 160 pages, 5 1/2 x 8 1/2". **\$295**
Order PFG-1, only.....

Troubleshooting with the Oscilloscope

by Bob Middleton. Explains how you can best use the scope to actually view and analyze electronic circuit actions, and apply what you see to more effective TV and radio troubleshooting. Practical chapters on scope operation, use of probes, signal tracing, visual alignment, signal testing, circuit analysis, and troubleshooting TV, Radio, and Hi-Fi. 128 pages; 5 1/2 x 8 1/2". Order TOS-1, only..... **\$250**

Troubleshooting with the VOM-VTVM

by Bob Middleton. Shows how to use these instruments for troubleshooting TV circuits. Tells how to check and interpret voltages; gives step-by-step procedures for analyzing every type of TV circuit. Also describes measurement and analysis of both AC and DC voltages, resistance, capacitance, and RF signals. 160 pages; 5 1/2 x 8 1/2". **\$250**
Order TWV-1, only.....

Phonograph Cartridge & Needle Replacement Guide
by the Howard W. Sams Technical Staff. Most comprehensive guide available to replacement cartridges and needles. Listed by original parts numbers and by equipment manufacturers' model and part numbers. Fully cross-referenced. 96 pages, 5 1/2 x 8 1/2". Order RCN-1, only..... **\$195**

HOWARD W. SAMS & CO., INC.

Order from your Sams Distributor today, or mail to Howard W. Sams & Co., Inc., Dept. PF-7
4300 W. 62nd Street, Indianapolis 6, Ind.

Send me the following books:

- TUB-7 IGS-1 PFG-1 TWV-1
 SSH-5 CSL-1 TOS-1 RCN-1

\$_____ enclosed. Send FREE Booklist

Name _____

Address _____

City _____ Zone _____ State _____

My Distributor is _____

IN CANADA: A. C. Simmonds & Sons, Ltd., Toronto 7

This feature is of value to someone who needs to monitor more than one frequency or station.

Selective Calling

So far, this discussion has been limited to nonselective radio paging techniques in which all receivers intercept all paging broadcasts. In many instances users would prefer that their receivers remain silent except when the call is for them.

One way to achieve calling selectivity in a short-range radio paging system is to use a different radio transmitting frequency for each person to be called. This is feasible in the Citizens band (CB) when no more than 23 different receivers are to be alerted. The portable receiver shown beside the base station in Fig. 2 is tuned to one of the CB channels. All other portable or fixed receivers used in the system are fixed-tuned to other CB channels. To page the subscriber carrying the receiver tuned to channel 2, for example, the operator sets the transmitter to channel 2. To page someone else, the transmitter is simply set to the appropriate channel.

The base-station transmitter shown in Fig. 2 is one of the new 23-channel CB transceivers which serves as both transmitter and monitor. Before transmitting, the operator can monitor the channel to determine if it is in use, and thus avoid interference to others. Naturally, the portable units are capable of receiving transmissions from other stations on the channels to which they are tuned.

A class-D CB station license is required when a regular CB set is used as the paging transmitter. No station license is required when a special transmitter or a modified CB transmitter is used, if operating with less than 100 mw of input power to the final RF stage (in accordance with Part 15, FCC Rules and Regulations).

Selective alerting of radio paging receivers that are all tuned to the same radio frequency is achieved by adding a digital or analog decoder to the receiver and an encoder to the paging transmitter.

When selective signaling is used, the paging transmitter can be used for both paging and two-way communication with mobile units. For



Fig. 2. A 23-channel CB transmitter used for paging personnel carrying pocket receivers.

example, a Civil Defense base station may be used without selective signaling for normal two-way communication. Then, to alert group members not on active duty, the base station operator may press a button which causes a special low-frequency tone to be transmitted. This tone actuates the decoders at all normally inactive monitor receivers, which turns on their loudspeakers and allows the ensuing voice message to be heard.

Only a very simple encoder and associated decoders are required when all standby monitor receivers are to be alerted simultaneously. Fig. 3 is a block diagram of such a system, and Fig. 4 is a schematic diagram of the encoder. When S1 in Fig 3 is held closed for an extended period (such as 10 seconds) the encoder trips, turning on the call lamp and the receiver's loudspeaker. The receiver remains in this state until manually reset by depressing S102 (Fig. 4).

In this system, the transmitted tone is at 2805 cps. This tone, picked off in the receiver's audio section, is fed into V1A (Fig. 4) whose plate circuit is tuned to 2805 cps by a parallel-resonant LC circuit. Audio signals at other frequencies are attenuated. The tone is rectified by diode M1 and its positive DC output drives V1B into conduction, causing relay M2 to pull in. The contacts of M2 apply a positive DC voltage through an 11 megohm resistor (R9) to a 1 mfd capacitor (C7) which charges slowly.

When the charge in C7 becomes great enough, neon lamp M4 conducts and applies a positive DC voltage to the grid of V2, causing it to conduct and pull in relay M3. This relay is latched through its

own contacts; the plate end of the winding of coil M3 is connected to ground through R12. The other set of relay contacts places the speaker in the circuit and applies DC to call lamp M5. Relay M3 remains locked in until momentary reset switch S102 is operated and jumpers the coil. Since it requires a 2805 cps tone of sufficient duration to charge C7, the encoder cannot be inadvertently tripped by voice or other tones.

To alert receivers individually, each must be equipped with an encoder responsive to a different tone frequency, or a combination of tones. To alert receivers in groups, the receivers in each group must be equipped with identical decoders, but different from those used in other groups.

The encoder may consist of two or more tone generators, employing LC circuits or vibrating reeds to determine frequency. Encoders may employ an LC circuit or resonant reed relays to respond to tones at the required frequencies.

Dial signaling (digital) is often used for individually alerting radio paging receivers. The base transmitter is equipped with a tone generator, operating at a single frequency, whose output is pulsed by a telephone dial. Each receiver is equipped with a dial pulse decoder which responds to its own preset number only, or in addition, to an all-call or group-call number.

In some systems employing dial signaling for calling two-way mobile units, a continuous tone is used for alerting all usually-inactive receivers simultaneously. The operator merely "pulls" the telephone dial from its normal position and



ASK YOUR WIFE
if she could use some extra Cannon terry cloth printed dish towels. If she says "yes" then

ASK YOUR JOBBER
how you can get them for her FREE with the purchase of certain PLANET condensers.

PLANET SALES CORP.
225 Belleville Ave.
Bloomfield, New Jersey

Circle 46 on literature card



World's Fastest Selling FM Wireless Microphone

IMP II

Transmits voice or signal with power and fidelity to any standard FM tuner or radio. Perfect for use where mike cords are inconvenient. For broadcasting, remote tape recording, communicating or hundreds of other applications in schools, churches, theatres, plants, stores, homes and sporting activities, indoors or out. Tunable: 88-108 mc band.

IMP II-221 Transmitter only... **39⁹⁵**
IMP II/M-222 Complete with built-in pin-head microphone **49⁹⁵**

See Distributor or write PF-7
kinematix, inc.
2040 West Washington Boulevard
Chicago, Ill. 60612 Area 312 • 666-0066

Made in U.S.A.

Circle 47 on literature card



MAKE EXTRA PROFITS WITH THIS NEW HEATHKIT® FM STEREO GENERATOR

ONLY \$99.00

- Everything you need for fast, simple servicing & alignment
- Produces all signals required for mono & stereo FM servicing

Enter the profitable field of mono & stereo FM servicing now! This new Heathkit FM stereo generator offers complete facilities for every alignment and trouble-shooting need. Signals generated by the IG-112 include audio or composite stereo signals for tuner, receiver and multiplex adapter adjustments... phase test for accurate alignment of subcarrier transformers... special SCA frequencies (65 & 67 kc) for aligning even the most advanced-design tuners... a crystal-controlled 19 kc (± 2 cps) pilot signal, adjustable from 0 to 10% to check the lock-in range of stereo receivers... sweep function with built-in markers for overall IF & RF alignment... a 100 mc RF carrier (adjustable ± 2 mc) mono or stereo modulated... and many more! Balanced 300 ohm RF output permits direct connection to the antenna terminals of unit under test without complicated matching networks! Complete with test leads and detailed stereo alignment instructions. Order your Heathkit IG-112 now for faster, easier servicing and extra profits in this greatly expanding field of stereo FM!

Kit IG-112... 10 lbs... \$10 dn., \$9 mo. \$99.00
Export model available for 115/230 VAC, 50-60 cps; write for prices.

HEATHKIT
by Design



FREE CATALOG

Over 250 exciting Heathkits available in easy-to-build kit form. Save 50% or more by doing the easy assembly yourself! Send for your free catalog today!

HEATH COMPANY, Dept. 25-71
Benton Harbor, Michigan 49023

Name _____ (Please Print)

Address _____

City _____ State _____ Zip _____

Prices & specifications subject to change without notice. TE-130

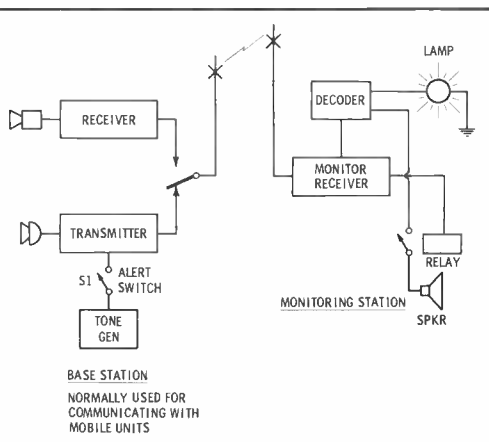

Fig. 3. A single tone alert system showing the Base Station and one Monitoring Station.

Surefire Winners



surefire
SCRATCH REMOVING COMPOUND

...for mar-free plastics

Surefire quickly buffs away hairline scratches from any rigid plastic surface. It is a fast *surefire* repair for plastic TV screens, radio and TV cabinets, testing equipment dials, plastic TV tube masks and aircraft or marine windshields. Surefire is a must for every dealer, repair shop and serviceman's tool caddy. Ask your dealer or distributor for Surefire #956—it's packed 12/5 oz. jars to the case.



surefire
ANTI-STATIC PLASTIC CLEANER

...static free, dust repellent

Surefire cleans and polishes any plastic surface while removing the static electric charge, thus rendering the surface *dust repellent*! Since Surefire will clean and polish glass as well...TV servicemen find it indispensable for cleaning *all* TV screens—used on plastic instrument dials it insures true static-free readings—It is a must for cleaning aircraft and marine windshields and is recommended for final polishing after Surefire Scratch Remover has been used. Ask for Surefire #950, the handy 8 oz. refillable dispenser flask—Surefire is also available in pint and 1 gal. sizes for economy.



WILCLEAN HAND CLEANER
...Hot or Cold

Wilclean, in any weather, cleans soiled or greasy hands in a flash—*with or without water!* Wilclean contains Hexachlorophene and soothing lanolin to protect the skin and is economical, too! Servicemen carry Wilclean #30, a 1# can, in their trucks and can clean their hands any time, anywhere, *even without water!* For the Repair Shops, Wilclean #30-2 is available, packed 2-5# cans with a handy wall dispenser. Ask for Surefire Wilclean Hand Cleaner from your favorite distributor.

Write Wilco Co., Dept. AID, 4425 Bandini Blvd., Los Angeles, California, 90023, or call your local distributor today!

surefire

Circle 48 on literature card

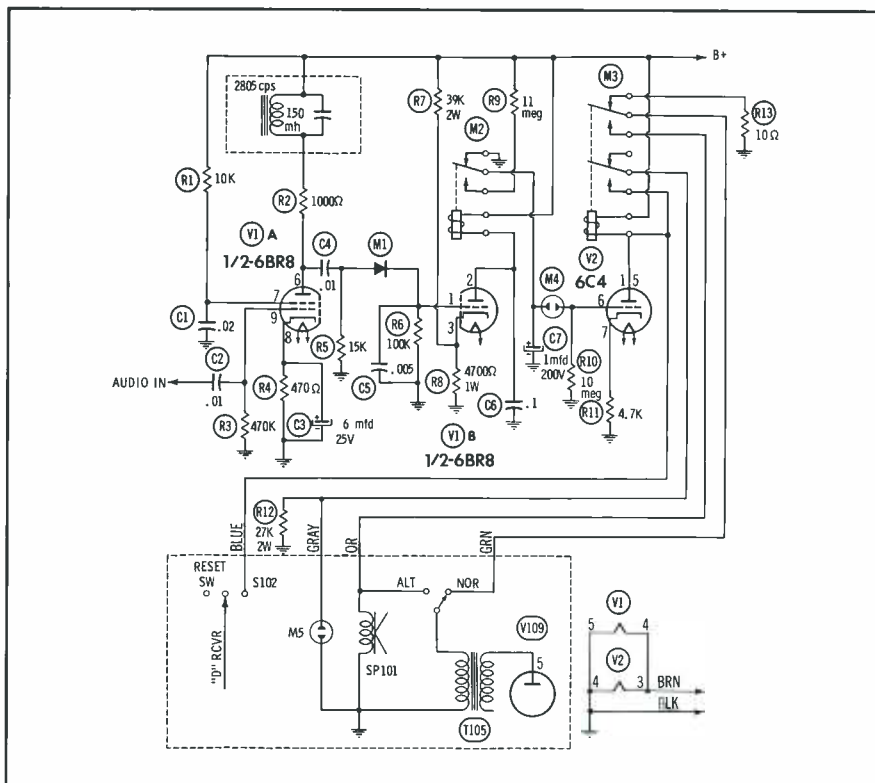

Fig. 4. Sustained tone decoder activates receiver speakers on receiving 2805 cps tone.

holds it there for 10 seconds. This causes a noninterrupted tone to be transmitted until the dial is released. If the tone is of sufficient duration, the normally silent paging receivers are made live, and all ensuing voice transmissions will be reproduced by their loudspeakers.

Tone signaling is also used to selectively alert persons carrying pocket paging receivers. These receivers are normally silent until a specific tone or combination of tones is intercepted. Then, a tiny loudspeaker is automatically turned on so the ensuing voice message can be heard.

Tone signaling, without voice, is widely used in radio paging systems. The *Pagemaster*, for example, sounds a "beep" when it intercepts a radio signal modulated by a specific tone combination. After the beep is heard, the user presses a button to reset his receiver to the standby position, and responds to the call in a prearranged manner. Some models are equipped with a lamp as well as a beeper.

The *Bell Boy*, furnished to radio paging subscribers by some telephone companies, is similar in appearance and operation to the *Pagemaster*. Both may be used for furnishing public radio paging service. The *Pagemaster* is also used in

private in-plant radio paging applications.

Private, tone signaling radio paging receivers can be alerted by an unlicensed low-power radio transmitter when operated in accordance with Part 15, FCC Rules and Regulations. For greater coverage, the paging transmitter may be licensed as a class-C Citizens-band station, under Part 19 of FCC rules. The class-C license may be used when the transmitter controls a remote device, but when no other form of intelligence except the coded tone is transmitted. Transmitter power is limited to 5 watts input except on 27.255 mc at which frequency as much as 30 watts is permitted.

For long-range radio paging, for private purposes, using either tone signaling or voice or both, the paging transmitter can be licensed in the Industrial Radio Service (business, manufacturers, etc.) or the land-transportation radio service (railroads, bus lines, etc.) on 27.235, 27.245, 27.255, 27.265 or 27.275 mc. These frequencies, except 27.255 mc, are free of interference from CB stations. Transmitter power up to 30 watts (input) is permitted, and there is no restriction on antenna height except when potential hazards to aircraft exist.

Either AM or FM, or even SSB,

may be used on these frequencies. To get a regular license, the paging transmitter must be FCC "type accepted." When a homemade, modified or another non-type-accepted transmitter is used, full technical information must be furnished to the FCC, and licensing is on a "developmental" basis. Until recently, all private microwave stations were licensed on a development basis. A developmental license differs from a regular license in that it can be modified, or cancelled without a hearing, if the FCC deems such action necessary.

Other frequencies in the 25-54 mc and 147-174 mc bands, on which only low power is authorized (under 3 watts), are also available for private radio paging applications. According to an FCC official, however, licensing might have to be on a developmental basis. There are frequencies, reserved for developmental use only, which might also be used. If you are planning a private radio paging system for yourself or a customer, and you are in doubt about available noncongested frequencies in your area, write to the Federal Communications Commission, Washington 25, D.C. and define your objectives.

While commercially available pocket paging receivers are mostly for use in the 25-54 mc or 147-174 mc range, mobile and fixed receivers for the 450-470 mc range (UHF) are available. Such receivers can be used to receive paging calls (voice, tone AE or voice and tone) from a class-B CB station on 465 mc or a class-A CB station on any of the channels in the 460-470 mc band.

Selling, installing, and servicing radio paging equipment, or servicing alone, can add to the income of the independent service shop operator. No license is required to service paging receivers, decoders, and encoders. Nor is a license required to service unlicensed paging transmitters operated under FCC rules Part 15; but, it is essential that the person doing the servicing is competent to certify that the transmitter operates in accordance with the rules. To service paging transmitters licensed as Citizens, Industrial (including business), Land Transportation, or Common Carrier radio stations, a second-class operator's license is required. ▲



How to turn crystal



into gold

You can strike it rich with the new Sonotone line of crystal cartridges. It offers direct replacements for "Ronette," "Vaco" and "BSR" models with typical Sonotone quality.

Here are the extras you get—New improved crystal elements for longer pickup life. Mono ("14T") and stereo ("20T") models. High output voltage. Modern turnover type for LP, 45 and 78 rpm records. Available with or without mounting brackets or turnover knobs to fit most arms.

Oh yes, they come in a slim, lightweight plastic tonearm, too. You have a choice of the mono ("14T") or stereo ("20T") cartridge. It's easy to install because it's prewired. It has a shielded cable, spring mounting post and a plated finger lift. It's complete with arm rest and all necessary hardware. Get details today. Write:

SONOTONE
audio products

Sonotone Corp., Electronic Applications Div., Elmsford, New York
Cartridges • Speakers • Microphones • Headphones • Hearing Aids • Batteries

Circle 49 on literature card

July, 1964/PF REPORTER 77

Transistorized Mikes

(Continued from Page 67)

two-transistor types. With proper current range maintained, transistorized mike sensitivity is far more uniform than that of carbon units. Therefore, less severe modulation limiting is needed, making possible higher speech quality and greater undistorted power output. To maintain both ruggedness and uniform sensitivity under varying conditions, very careful circuit design and component selection is necessary. One manufacturer claims his micro-

phone will operate uniformly from + 158°F down to -40°F.

Let's take a closer look at physical construction, circuitry, and servicing of transistorized units.

Most Can Be Repaired

It is probably a good idea to set an absolute rule that no attempt be made to repair a damaged *element* in a transistorized microphone; if the element is bad, either *replace* it or send the complete assembly back to the factory for repair. However, many of the transistor ampli-

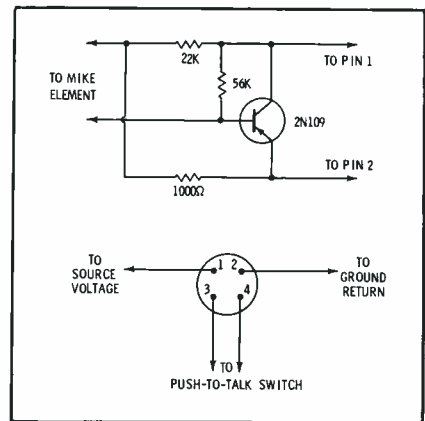

Fig. 6. Amplified signal taken from collector.

fier modules within the assembly are easy to troubleshoot and repair if a few precautions are exercised.

When replacing transistors, reconnecting amplifiers, or wiring cable connections, be sure to observe correct polarity. If the polarity is reversed at any of these points, the transistors are likely to burn up instantly when the voltage is applied. One other precaution is very important: Since all transistorized microphones use some type of permanent magnet in their elements, be very careful to prevent attraction of metal filings or dust when the case is open. Inside the element, such foreign matter would cause irreparable damage.

Most microphone amplifiers are constructed on small phenolic boards; the circuits are either *printed* or wired between eyelets and/or other terminals. The majority of amplifier boards are mounted for easy removal from the microphone case (if the leads are not long enough they can be unsoldered). The usual rules for working with printed circuits and transistors should be followed when checking or replacing parts on these boards.

Do not connect or disconnect

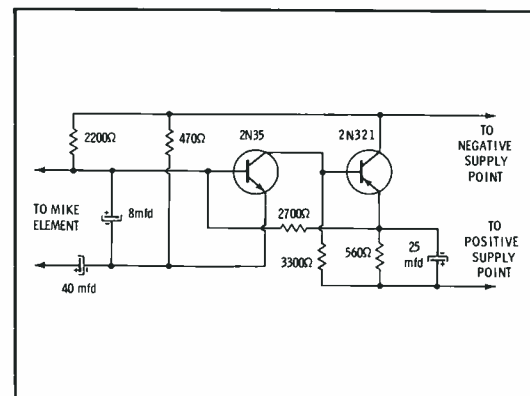

Fig. 7. Direct coupling (collector to base) requires both PNP and NPN type transistors.

COMCO

Dealerships

FOR
2-WAY RADIO SALES AND SERVICE
NOW AVAILABLE IN MANY AREAS



PRODUCTS

HF-SSB (1.6-16 Mc/s.)

- Point-to-point
- Marine, ship and shore stations
- Military

VHF-AM (108-156 Mc/s.)

- Aeronautical ground stations
- Airport vehicles
- Point-to-point
- Military

UHF-AM (220-400 Mc/s.)

- Ground-to-Air
- Airport vehicles
- Military

VHF-FM (25-54, 144-174 Mc/s.)

- Mobile
- Base
- Repeater
- Marine
- Portable
- Military
- Military
- Point-to-point
- Voice
- RTTY
- Data

UHF-FM (400-420, 450-482 Mc/s.)

- Mobile
- Base
- Repeater
- Portable
- Military
- Point-to-point
- Voice
- RTTY
- Data

- Antennas
- Transmission line
- Remote controls
- Line termination panels
- Tone control and signaling

COMCO offers dealers reliable, high performance two-way radio equipment, backed by 25 years of engineering and production experience.

A complete line of two-way equipment is sold—Directly to U. S. Military Agencies, to other two-way radio manufacturers, and by dealers throughout the world.

You can qualify for a dealership if you have —

✓ An FCC second-class radiotelephone license.

✓ A shop with necessary test equipment for installation and maintenance of VHF-FM equipment.

✓ An established business with good credit rating.

✓ Enthusiasm to promote sales of COMCO radios.

For complete information on available dealerships in your area, write or telephone today to Frederick R. Macklin, Sales Manager.

COMMUNICATIONS COMPANY

Post Office Box 520
Coral Gables, Florida 33134
Telephone (Area 305) 445-2671



Fig. 8. Transistorized microphone has printed circuit board.

transistors while supply voltage is applied to the amplifier, whether they are plugged into sockets or soldered—if this rule is not observed, voltage transients could cause breakdown damage. Always remove the transistor before applying a soldering iron to socket terminals. If you must solder transistor leads, use a 25- to 50-watt iron, with pliers between the tip and the transistor as a heat sink. Solder quickly; failure to follow this practice could cause thermal transistor breakdown. Also, avoid overheating the thin copper conductors of printed circuits, since they might de-laminate and destroy circuit continuity.

A typical amplifier circuit is shown in Fig. 6, with a more elaborate two-transistor version shown in Fig. 7. The majority of these units are of the single-transistor type such as the one pictured in Fig. 8. The following troubleshooting procedure is applicable to almost any microphone you may encounter.

The cable between the microphone and transmitter consists of four wires, two of which connect the push-to-talk switch to the microphone element. The other wires supply power to the transistor circuit. This cable is subjected to constant movement, and wire breakage at the connecting ends is a common trouble. This can be found with an ohmmeter. Test for continuity from the connector pins to the corresponding tie points inside the microphone case. After assuring that the wires are not broken and all connections are properly soldered, the ohmmeter can be an effective tool in further troubleshooting.

Power need not be applied during troubleshooting as voltage measurements are nonessential. Many of these units use plug-in transistors, making substitution quick and easy. With the transistor removed from the circuit the ohmmeter can be used to check for an increase in resistance values or possible leakage, opens, or shorts in capacitors. However, resistors and capacitors are less likely to fail under normal use than is the transistor.

Not all transistor amplifiers are so easy to repair. We opened one assembly that was so neatly packaged we almost didn't find the transistor circuit; by the time we did locate it repair was impossible. This variety is definitely not to be repaired in the field since the *entire amplifier* is within the magnetic circuit of the dynamic element. By employing such construction, the manufacturer has achieved amplifier shielding, both electrical and magnetic.

Summary

Produced by several manufacturers, transistorized microphones are lightweight and reliable. With the additional advantage of efficiency in cancelling background noise, these compact units are particularly suited for mobile communications. ▲

Communications, mobile radio...

A First Class FCC License

...or Your Money Back!



Your key to future success in electronics is a First-Class FCC License. It will permit you to operate and maintain transmitting equipment used in aviation, broadcasting, marine, microwave, mobile communications, or Citizens-Band. Cleveland Institute home study is the ideal way to get your FCC License. Here's why:

Our training programs will *quickly* prepare you for a First-Class Commercial Radio Telephone License with a Radar Endorsement. Should you fail to pass the FCC examination after completing your course, you will get a *full refund* of all tuition payments. You get an FCC License . . . or your money back!

You owe it to yourself, your family, your future to get the complete details on our "proven effective" Cleveland Institute home study. Just send the coupon below TODAY. There's no obligation.

Mail Coupon TODAY For FREE Catalog

Cleveland Institute of Electronics
1776 E. 17th St., Dept. PF 14
Cleveland, Ohio 44114

Please send FREE Career Information prepared to help me get ahead in Electronics, without further obligation.

CHECK AREA OF MOST INTEREST—

- | | |
|---|--|
| <input type="checkbox"/> Electronics Technology | <input type="checkbox"/> First Class FCC License |
| <input type="checkbox"/> Industrial Electronics | <input type="checkbox"/> Electronic Communications |
| <input type="checkbox"/> Broadcast Engineering | <input type="checkbox"/> Advanced Engineering |



Your present occupation _____

Name _____ Age _____
(please print)

Address _____

City _____ State _____ Zip _____

Accredited Member National Home Study Council

"Eliminates Soldering"

PERFECT *Audio*

**"PIN-PLUG"
CRIMPER**

SLIP WIRE IN "PIN-PLUG"
INSERT IN TOOL AND SQUEEZE
JOB IS DONE



USE END OF BLADE
AS SCREWDRIVER

U. S. Pat. 2,878,698
Canadian Pat. 592,702

USE END OF TOOL TO
PUSH ON GROUND CONNECTOR

Useful in making hi-fi, audio and sound, radio, phone, and TV equipment connections.



only **\$1.25** C-rings 1c each

Get the tool that makes solid electrical pin-plug connections without soldering or destroying pin form. Use one end for pin crimping, the other to push on C-ring clamp for braided-shield ground connection. Nothing like it anywhere.

MODEL PT-1

Picture-Tube Repair Tool

Also for—5U4, 6SN7, 6BQ6, etc.

Model LC-3 for 5/32" pin diameter

At your parts distributor or write us

BERNS

Mfg. Co.
9853 Chalmers,
Detroit 13, Mich

Circle 26 on literature card

Modulators

(Continued from Page 70)

termination and line-bias current. The unmodulated carrier wave encounters a certain delay that depends on the DC no-modulation current. This current is set by the bias control in the emitter-follower modulator stage.

By changing the delay line bias, the time delay of the modulated RF can be increased or decreased relative to the nonmodulated-RF travel time. Thus, the phase of the RF wave can be advanced or retarded relative to the unmodulated RF reference.

The audio signal is applied to the base input of the emitter follower and causes the line bias to follow the positive and negative voice-frequency variations. The time delay in the line varies correspondingly; an FM resultant is produced.

Since the RF time delay (rather than phase) is being changed in a proper manner relative to the line bias current variations, a linear response (frequency deviation vs modulating frequency) is obtained. It is not necessary that the instantaneous deviation control type of limiting be used. A simple amplitude clipping arrangement is suitable.

Conclusion

Phase modulators can be used effectively in communications transmitters to produce frequency modulation. Although the circuits vary somewhat among transmitters, the underlying principles are the same in all units. Since the use of this technique is widespread, the serviceman who deals with this type of equipment must have an understanding of the fundamentals involved. ▲

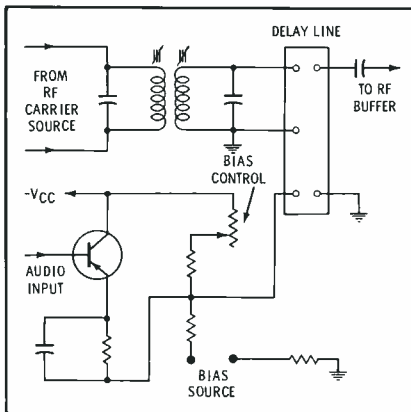
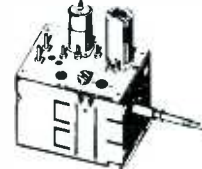

Fig. 7. Delay line modulator uses transistor.

TV TUNERS

Rebuilt—Exchanged



\$9.50*
Plus
Shipping
Charges

All Makes—All Models

- Includes all parts except tubes
- 90 day full warranty
- All tuners cleaned, lubed, repaired and aligned with crystal controlled factory equipment to factory specifications, by factory trained technicians.
- 1 day service

Give model number of set and complaint. Include tubes, shields, cover and all parts, broken or not.

*Practical Repairs

VALLEY TV TUNER SERVICE

5641 Cahuenga Blvd. PO 9-4730
North Hollywood, California

Circle 52 on literature card

**NEW
SUPER
HUSH**

TV TUNER CLEANER

ENGINEERED FOR TUNERS
MADE WITH PLASTIC PARTS

From the purest chemicals available for cleaning plastic boards with printed circuits. HUSH lubricates with Electro-Silicone for longest possible protection. Available in 8 oz. and 16 oz. Spray Can with plastic needle.

**CHEMICAL ELECTRONIC
ENGINEERING, INC.**
MATAWAN, N. J.

Circle 27 on literature card

CORRECT LOW VOLTAGE



WITH A

terado

**VARIABLE
VOLTAGE ADJUSTER**



Electronic equipment, including TV, operates best at the 115-120 volts for which it is designed. Where high or low voltage affect the performance and operating life of tubes and other components, use a Terado Voltage Adjuster on your service

calls. Will correct any voltage within a 95 to 135 range to a normal 115-120. You'll sell 'em too! Great for TV, hi-fi, and universal A.C. motors in low or high voltage areas. Saturn (shown; to 500 Watt)

Dealer Net..... **\$14.65**

Polaris (same without meter)
Dealer Net..... **\$ 9.20**

Planet (up to 300 Watt) Dealer Net. **\$ 7.80**

See your electronic parts jobber, or write:

terado CORPORATION
1073 Raymond Ave.
St. Paul 8, Minnesota
In Canada, Atlas Radio Corp., Ltd., Toronto, Ont.

Circle 53 on literature card



ELECTRONIC DUST COUNTER IMPROVES RCA PICTURE TUBES

Strict environmental control extends electron gun life and performance

Even the smallest particle of dust can affect the life and precision performance of an electron gun in a television picture tube. In order to assure ultra-clean conditions for assembling guns that go into Silverama® Picture Tubes, RCA designed and built a space-age white room in its Marion, Indiana, plant.

Air in the white room is controlled by an electrostatic precipitator-type air conditioner. Higher than normal air pressure is maintained in the white room so no outside air can enter. At the entrance, "sticky floor mats" remove dust from workers' shoes. Workers wear lint-free Dacron smocks, lint-free nylon gloves, and rubber finger cots.

Yet, in addition to these precautions, RCA continually monitors

the white room's dust count by means of the digital-dust counter shown in the photo above. The unit is so sensitive it counts all dust particles from 0.32 micron (a micron is about one 39-millionth of an inch) to 8 microns. Only when the "dust count" is below an acceptable level can electron guns be processed.

These exceptionally strict environmental controls are another reason why you can be sure of customer satisfaction when you install an RCA Silverama Picture Tube.

Silverama is made with an all-new electron gun, finest parts and materials, and a glass envelope that has been thoroughly cleaned and inspected prior to re-use.

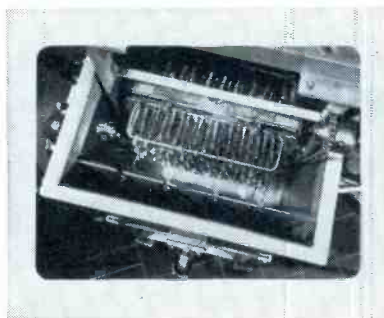

Electron gun mounts are washed by ultra-sonic vibration in extra-pure water to remove microscopic particles.

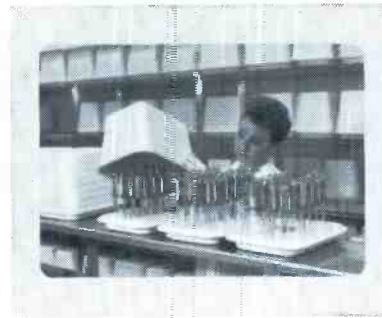

Electron guns, after drying, are kept in covered racks as further assurance against dust contamination.

RCA ELECTRONIC COMPONENTS AND DEVICES, HARRISON, N. J.



The Most Trusted Name in Electronics

WHAT'S IN A FUSE?

Only a fuse element, glass & caps?

No! Every fuse carries
with it the skill and quality of its manufacturer.

You can't reach out and touch or taste this
you can't even be sure it will do
its job when needed except
by purchasing from a company
that has the know how of 30 years
of manufacturing fine fuses.

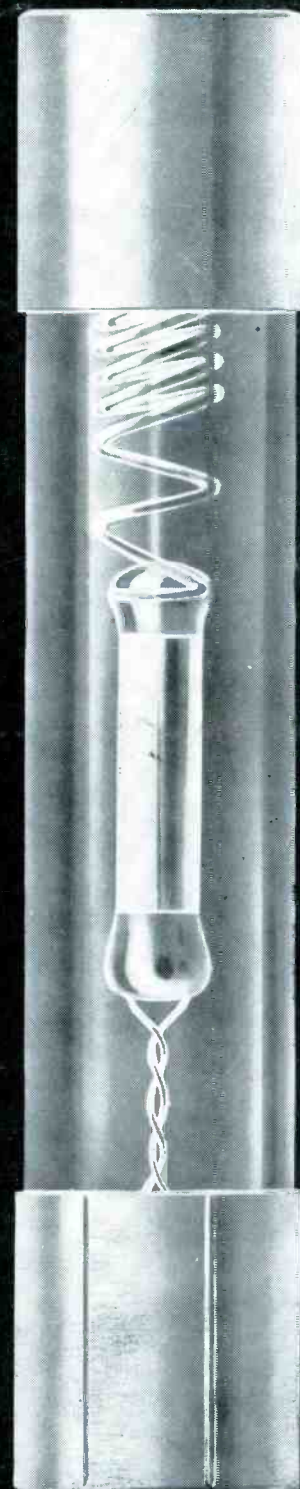
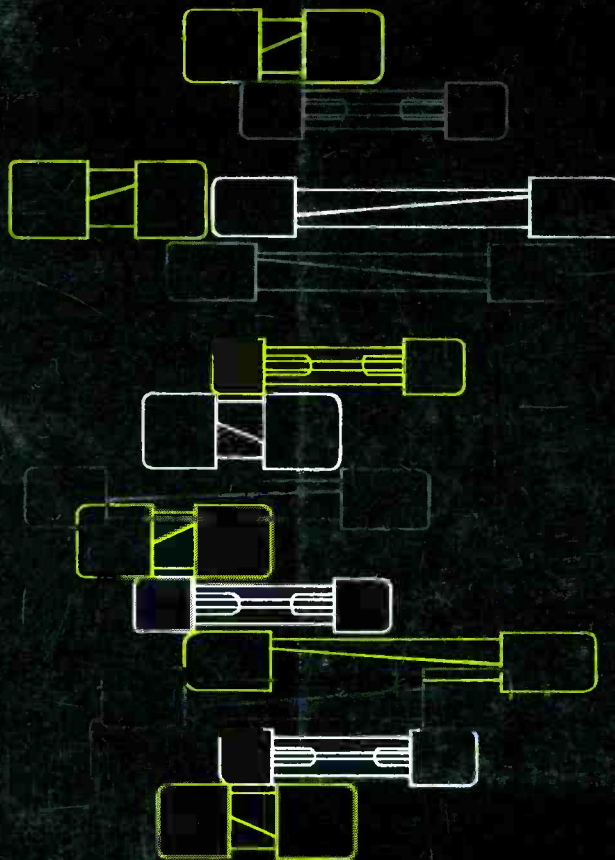

BURTON BROWNE ADVERTISING

LITTELFUSE

1865 Miner Street - Des Plaines, Illinois

Circle 54 on literature card

www.americanradiohistory.com