

FEBRUARY, 1964

50 CENTS



PHOTO PACI REPORTER

including **Electronic Servicing**

transistor ignition systems

Servicing Procedures

PLUS Color Chassis or CRT?
An Inside Look at Synchroguide
New AFC System for FM

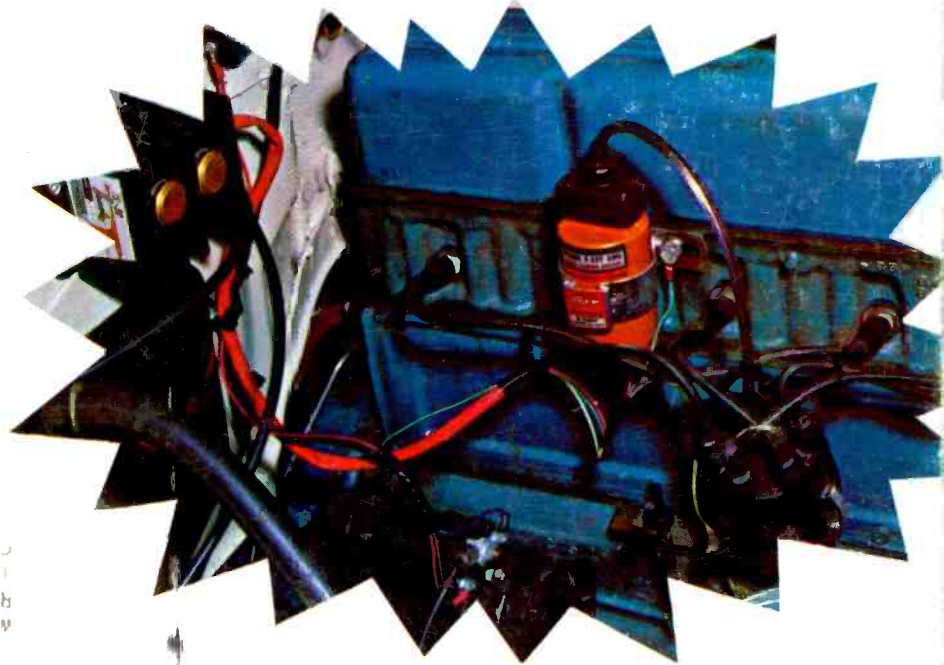
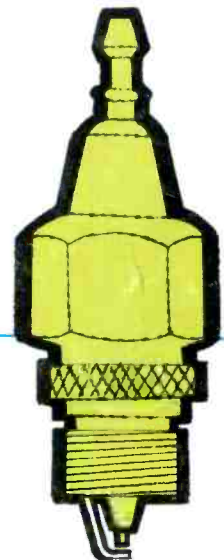

A 22 1104 1200
AM. M. GAVIS
RAD. & TV SERV.
118 RIVERSIDE AVE.
CANNON CITY, COLO.

WORLD'S MOST BEAUTIFUL BEST PERFORMING ALL CHANNEL UHF CONVERTER

by *standard kollsman*

World's Largest Manufacturer of Television Tuners



Inspired designer styling in beige and brown tones with "sunburst" gold knobs to harmonize with modern TV cabinet design. The new Model "A" converter takes its place tastefully and unobtrusively on TV set or close by on table or shelf and looks the fine high fidelity instrument that it is.

Tuning is simple. The Model "A" is loaded with "Fringe area" power for sharp, clear reception wherever one may be. One knob provides for complete channel coverage plus fine tuning. The second knob is for switching to UHF or VHF and turns on both converter and TV set. The built-in UHF/VHF coupler hooks up in about a minute with only a screwdriver. The Model "A" is far and away the most advanced UHF Converter money can buy.

12 GOOD REASONS WHY THE MODEL "A" IS YOUR BEST BUY

- **EARNs YOU MORE PROFIT** because it's easier to sell.
- **MORE PICTURE POWER** by using latest nuvistor amplifier circuits for better fringe area reception.
- **EASY TUNING**—Two speed ball bearing planetary drive uses a single knob for fine tuning the picture. Not a string drive.
- **FUNCTION KNOB**—Switches VHF, UHF, and turns converter and TV set on/off at the same time. TV set on/off switch can be left in "on" position at all times.
- **RELIABILITY**—6DZ4 tube and nuvistor for longer life as well as better performance than tube types previously used in UHF converters. Sliding contacts eliminated in the main tuning circuits through use of a service free 3-gang tuning element.
- **VERY LOW DRIFT.**
- **RADIATION SPECIFICATIONS**—Complies with requirements of Federal Communications Commission for all TV sets.
- **EASY HOOK-UP**—Use only a screwdriver to connect to antenna lead, and 300 ohm antenna lead to TV set.
- **POWER RECEPTACLE**—built into back of chassis to plug in the TV power cord.
- **SAFE**—Isolation transformer provides "cold" chassis.
- **ACTIVE COMPONENTS**—6DZ4 oscillator, IN82A mixer, 6DS4 nuvistor I.F. amplifier.
- **FREQUENCY RANGE**—Channels 14 through 83.

GENERAL SPECIFICATIONS

UL Approved. Line cord—a full 6 ft. Power: 110-125V AC only 50/60 cycle. 10/12 watts at nominal line voltage. Shipping weight—6 lbs. Dimensions—11¼" x 5¾" x 3".

NEW MODEL "B" UHF CONVERTER

Gives good urban reception, and it's easy on the budget. Similar to Model "A" less 6DS4 nuvistor IF amplifier circuit and AC outlet.



Circle 1 on literature card

ONE FULL YEAR WARRANTY ON MATERIAL AND WORKMANSHIP except tubes which are warranted for 6 months.



Standard Kollsman
INDUSTRIES INC.
2085 NORTH HAWTHORNE AVE., MELROSE PARK, ILLINOIS

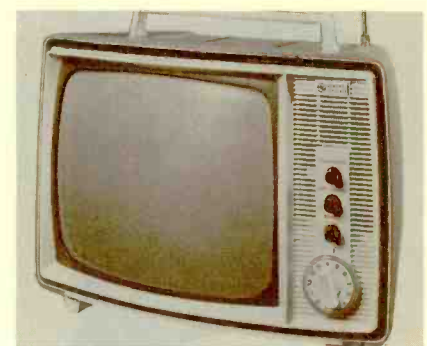
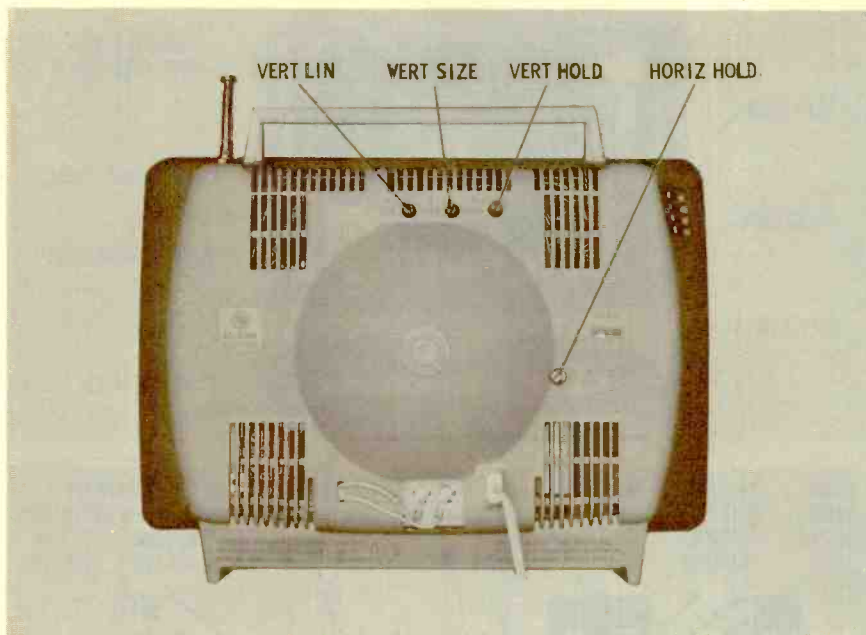

**General Electric
Model M110YBG
Chassis 5Y**

The personal portable shown here is General Electric's latest contribution to the television industry. It is extremely light, weighing less than 13 pounds. The compact design consists of two printed boards held together by small braces and assembled to fit around the neck of the picture tube. The picture tube is an 11AP4, having a 60-square-inch viewing area. Only nine other tubes complete the complement of this set. Three of the more familiar types are: 3GK5 RF amplifier, 6EA8 mixer-oscillator, and 1X2B high voltage rectifier. The remaining six tubes are all compactrons—either dual or triple purpose types. The two-stage video IF strip uses an 11AR11; a 15BD11 is used as the video output, sound IF amplifier, and sync separator. A 17BF11 completes the audio circuit, functioning as both detector and output. The vertical circuit has a 17JZ8 as its multivibrator and output. The horizontal AFC-oscillator is an 8B10, followed by a 33GT7 for horizontal output and damper (later models change to a 33GY7). The 33GT7 and 33GY7 are *not* interchangeable; in the GT7, pin 10 is the screen grid, while the GY7 has pin 11 connected to its screen.

The 140 volts B+ for this chassis is derived from a single silicon rectifier. Protection for this circuit is afforded by a 5 ohm, 5 watt fusible resistor (plug-in type). One other semiconductor is used—a germanium diode as the video detector.

Depicted in one of the photos is the unusual connection to the 1X2B. This tube has no mounting socket; the individual wires are connected directly to the tube pins. The two filament wires are connected to pins 2 and 9; the picture tube anode lead goes to pin 1 (pins 1 and 9 are connected together inside the tube).

To service this chassis, you must first disconnect all antenna leads, remove four screws from the cabinet front, and remove the wrap-around cover. One screw on top of the tuner holds the ground strap, another fastens the chassis to the top mounting bracket, and a third holds the cabinet front. After disconnecting the CRT anode lead, you can pull the chassis away from the front.

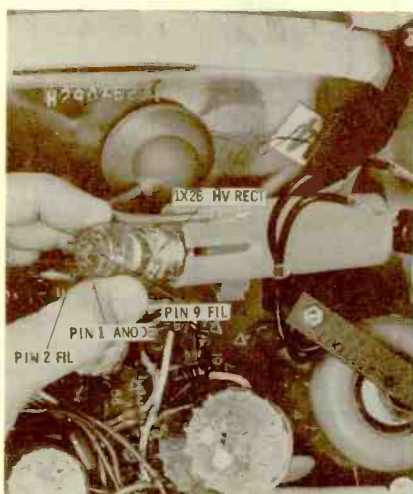
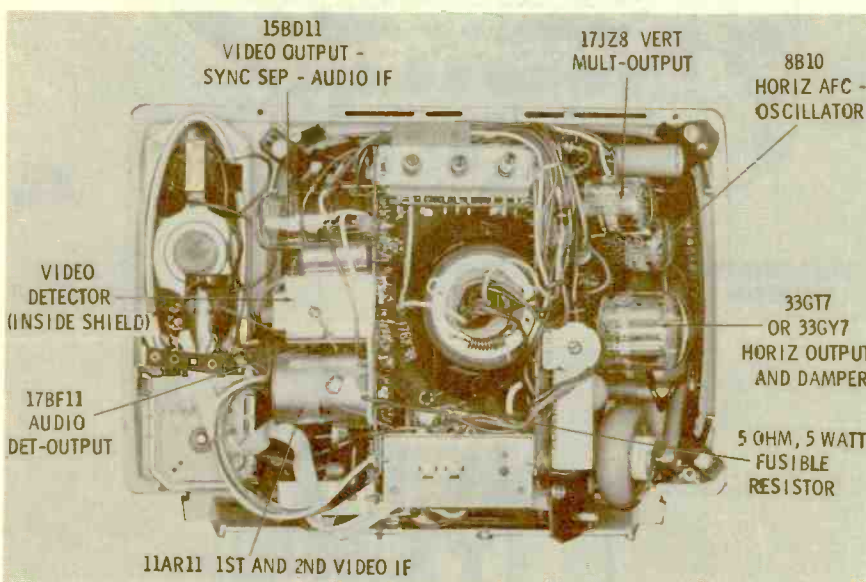

PF REPORTER, for February, 1964. Vol. 14, No. 2. PF REPORTER is published monthly by Howard W. Sams & Co., Inc., 4300 W. 62nd St., Indianapolis 6, Indiana. Second-class postage paid at Indianapolis, Indiana. 1, 2 & 3 year subscription prices: U.S.A., its possessions, and Canada: \$5.00, \$8.00, \$10.00. All other countries: \$6.00, \$10.00, \$13.00. Current single issues 50¢ each; back issues 65¢ each.

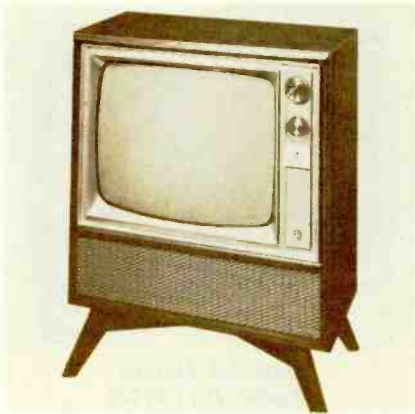

**Motorola
Model Y23K89
Chassis TS-586**

The VHF-UHF receiver pictured here is a 23" console model using a 23DAP4 picture tube. This same basic chassis, with minor modifications, is also used in the 19" models. The *small neck* CRT used in this set has a deflection angle of only 94°; so if you're servicing this set using a standard 110° test tube, don't be surprised to find insufficient sweep.

The series-parallel filament string has two dropping resistors—a 97 ohm, 10 watt in one parallel branch and a 105 ohm, 10 watt in the other. The only tubes common to both branches are the damper, picture tube, and UHF oscillator. B+ voltage is derived from a single silicon rectifier, protected by a 50 ohm, 10 watt surge-limiting resistor. A circuit breaker is used for overall protection of the set. The AC input plug is polarized to help eliminate shock hazards found in some "hot chassis" sets.

Three 6BZ6's make up the video IF strip, with the video output stage utilizing a 16GK6. Three 9A8's are used; one as an AGC keyer-noise inverter, another for sync separator-horizontal oscillator, the third as the first half of a vertical multi-vibrator and as the sound IF. A 15CW5 makes up the other half of the combination vertical circuit. The audio output stage also uses a 15CW5. The horizontal sweep circuit is composed of a 27GB5 output, 16AQ3 damper, and 3A3 high voltage rectifier.

The video detector is a germanium diode. Horizontal AFC action is provided by two signal diodes connected with their cathodes common. No modules are used in this chassis, permitting normal component replacement.

Focus may be varied by connecting to either B+, boost, or ground (see photo). The width is increased or decreased by means of a jumper that either adds or removes a 68 mmf capacitor across the horizontal yoke windings.

Oscillator slugs for channels 6 through 13 are accessible for adjustment by simply removing the channel selector and fine tuning knobs; channels 2 through 5 don't have slugs, so if adjustment is required it will be necessary to remove the tuner cover and expand or compress the coils.

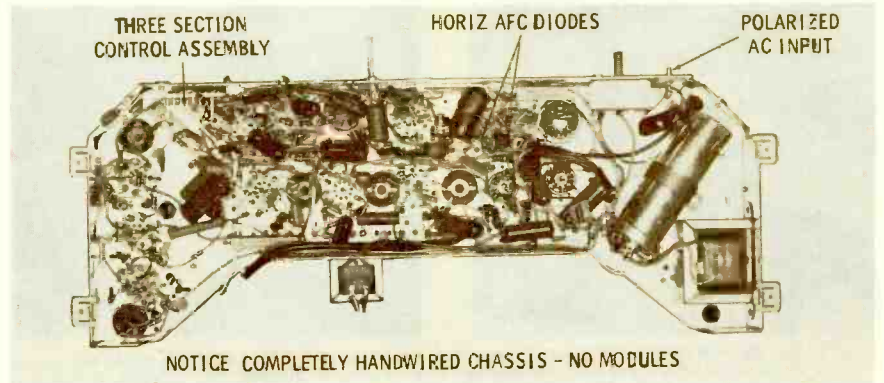
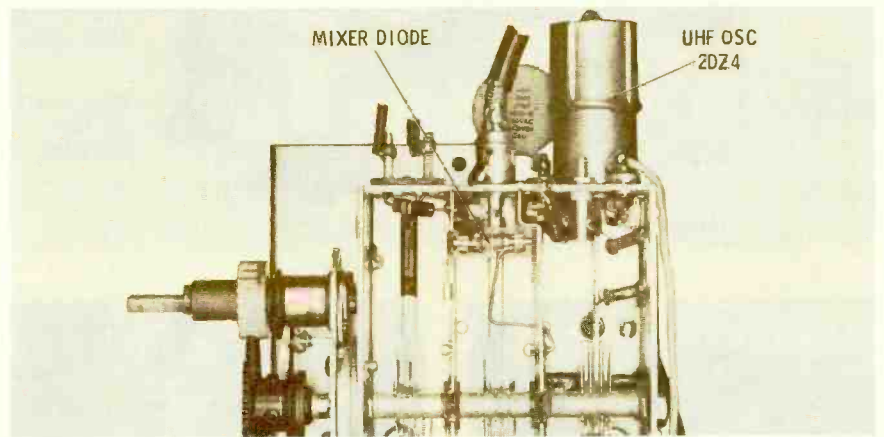
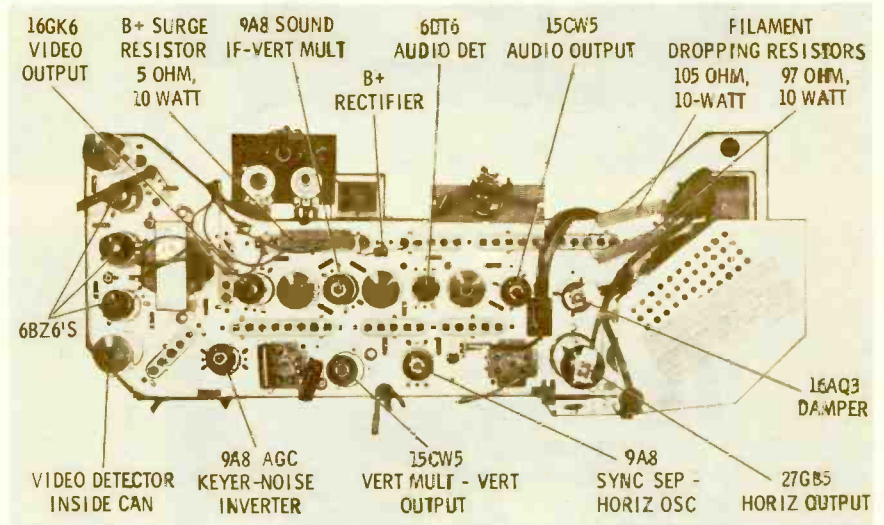
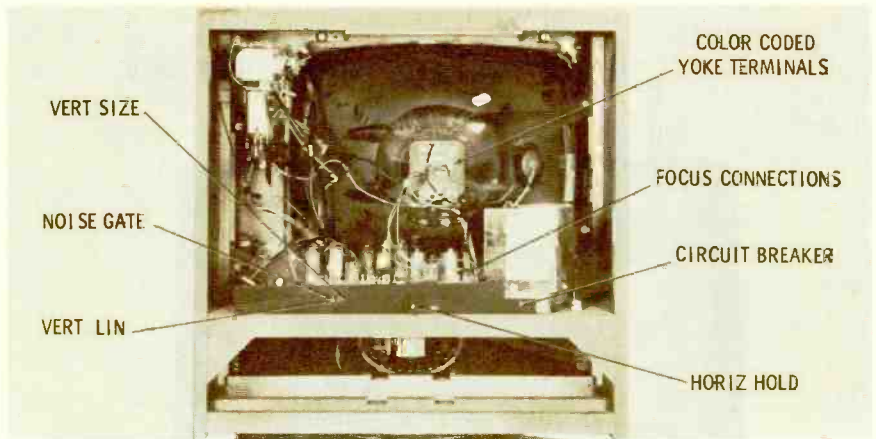



**Panasonic
Model Mitey 9**

This Japanese import is a 9" transistorized TV that can be operated on either 117 volts AC or 12 volts DC. The 12 volts is supplied by a nickel-cadmium battery or can be obtained from an automobile battery by connection to the cigarette lighter receptacle. When the set is operating on AC, a four-section selenium rectifier develops the 12 volts to recharge the battery. Two protective fuses are found in the power supply—a .4 amp and a 2 amp.

This set is completely transistorized except for three 5642's used as high voltage rectifiers. The three 5642's are connected as voltage triplers and supply an anode voltage of 9.5 kv. The only other tube is the 9", 90° picture tube, whose filament operates on 12 volts DC at 64 ma.

This set uses 27 transistors, 20 diodes, 1 thermistor, 1 VDR, and 1 posistor (a component with positive temperature coefficient, used to keep vertical sweep constant). There are two printed boards—one containing the video, audio, and AGC circuits, and the other containing sync and deflection circuits. The horizontal output, high voltage, and power supply circuits are not on a printed board.

Servicing is begun by removing the rear cover (held by screws in the lower corners). This gives access to the deflection board. There is a metal plate on the bottom of the receiver, covering the video and sound board; it is held by six screws. Either printed board can be swung out for access to its component side merely by removing a screw in each corner. If you desire to remove a board from the chassis, you can do so by pulling it out of its hinge and unplugging the wires. There are four wires to unplug on the video and sound board, and three on the deflection board.

To remove the picture tube, you must first remove the cabinet back and the front panel; the panel is held by two long screws inside the top of the cabinet, and two screws under the front. After you remove four screws from the corners of the picture tube mounting bracket, you can slide the CRT forward.

You'll find an additional circuit in this set that is used in the power supply to provide constant output voltage, regardless of input-power fluctuations.

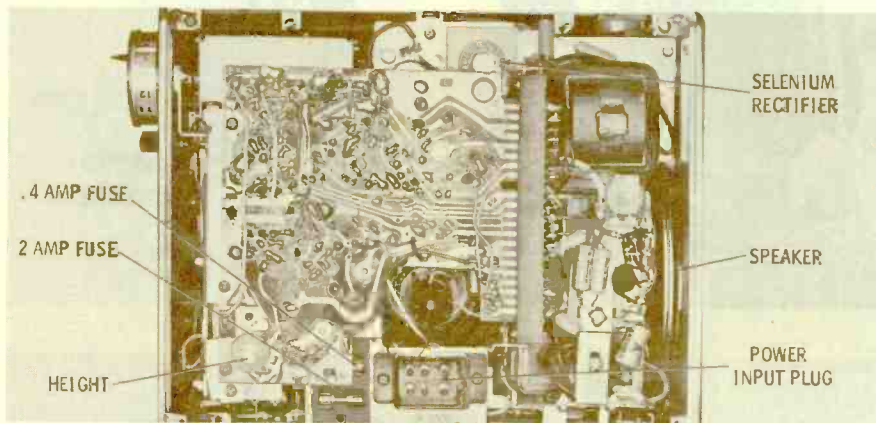
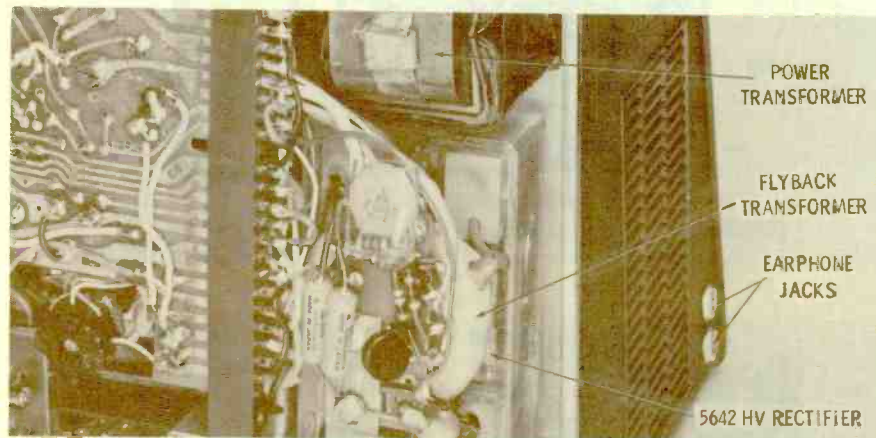
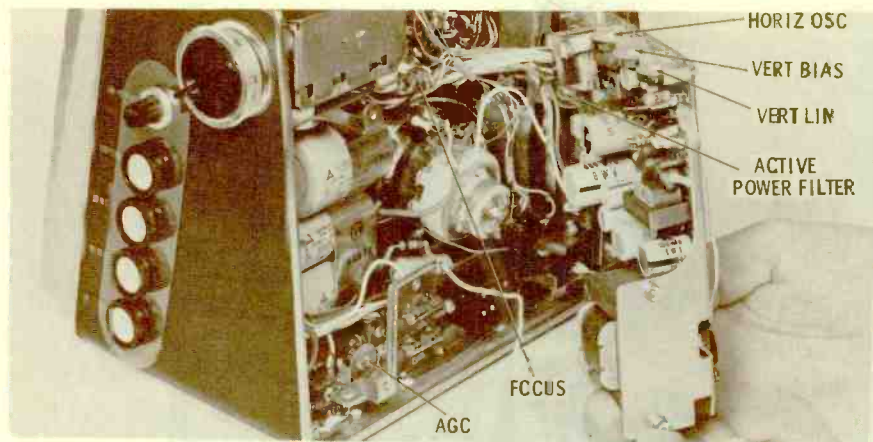

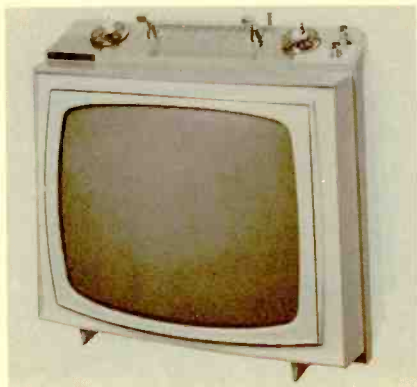

RCA
Model 64A030MU
Chassis KCS146

After April 30, 1964, all TV sets manufactured for home entertainment must be equipped for UHF reception. RCA is ahead of the deadline in this new light-weight 16" portable that features an all channel UHF tuner. Pointed out in the photos are oscillator adjustments for both ends of the UHF band. UHF operation is sometimes bothered by unwanted oscillations generated within the chassis; two new tubes in this chassis are designed to suppress these oscillations: a 6HZ6 audio detector and a 17JB6 horizontal output. The latter tube has a suppressor grid for connecting approximately 50 volts to eliminate parasitic oscillations within the tube.

This chassis is considerably changed from previous ones used by RCA. There is only one printed circuit board, but a number of new tubes. The two-stage IF section uses frame-grid 4JD6 and 4JC6; an extremely high-gain video output stage uses pentode-triode 11KV8, the triode section of which is the sound IF amplifier. A 12FX5 serves as the audio output, and in the combined vertical multivibrator and output circuits, you'll find a 13GF7 novar.

B+ is developed by two silicon rectifiers in a halfwave doubler circuit, protected by a 5 ohm fusible resistor and a special .4 amp chemical fuse. Both the resistor and fuse are plug-in types. The rectifiers are mounted on feedthrough capacitors on top of the chassis, so they can be replaced without removing the chassis. This transformerless portable has no protection for the series filament string.

The horizontal oscillator is an 8FQ7 and is controlled by a common-cathode selenium AFC diode. A germanium diode is used as the video detector; it's located under a shield that covers the final IF transformer. All controls, except the volume and brightness, are mounted on the printed board and are adjustable from the rear of the cabinet.

A monopole antenna is built in for VHF; however, external antenna connections are available for both VHF and UHF. The VHF tuner uses a neutralized triode 3GK5 RF amplifier and a new type 5KE8 mixer-oscillator.

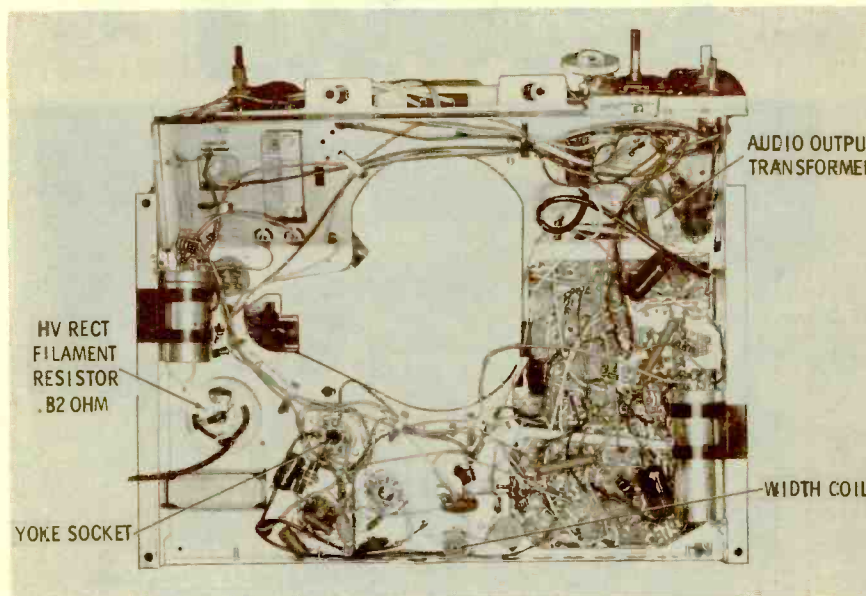
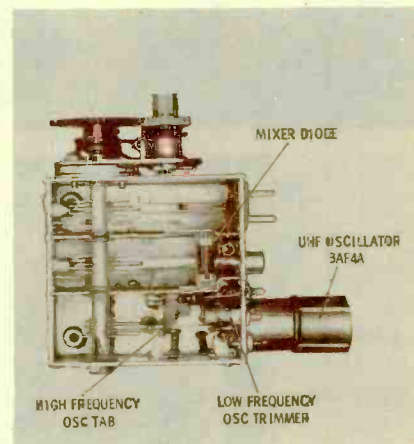
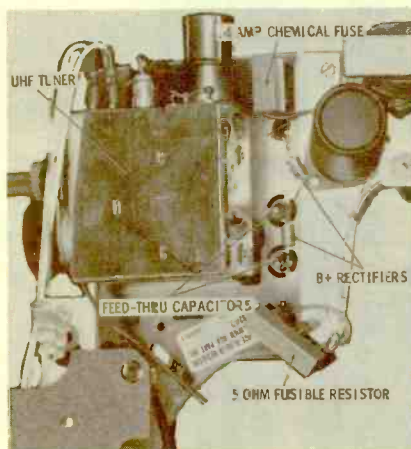
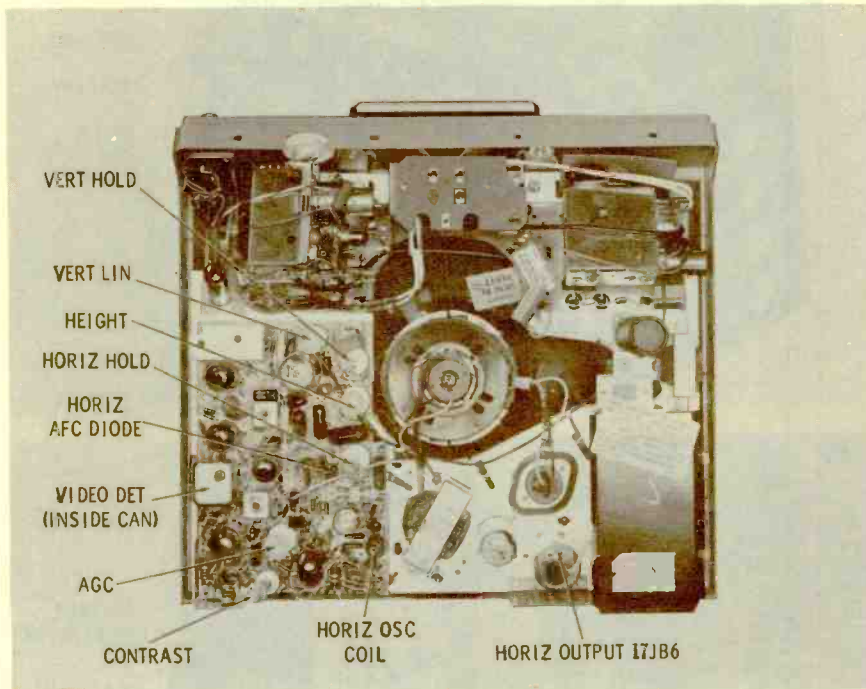

See PHOTOFACT Set 568, Folder 2

Mfr: Coronado Chassis No. S15

Card No: CO S15-1

Section Affected: Raster.

Symptoms: White vertical lines in raster.

Cause; Open resistor in horizontal deflection circuit.

What To Do: Replace R52 (8.2K).

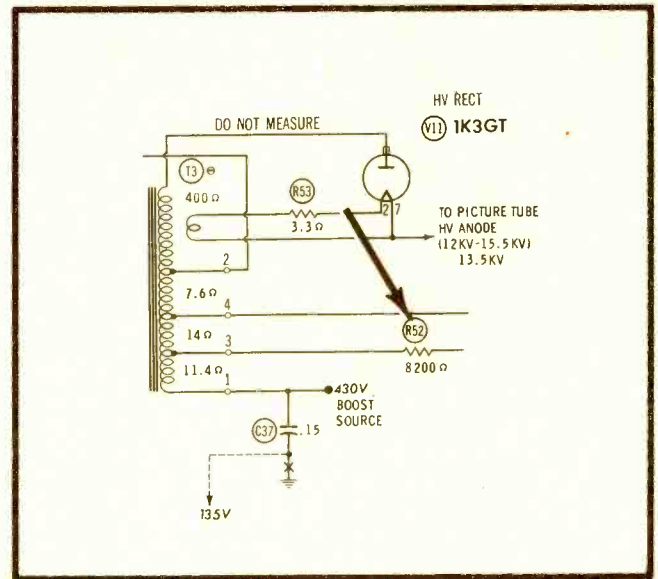

Mfr: Coronado Chassis No. S15

Card No: CO S15-2

Section Affected: Raster and pix.

Symptoms: Poor vertical linearity; bottom fold-over.

Cause: Leaky capacitor in grid circuit of V7.

What To Do: Replace C25 (.047 mfd).

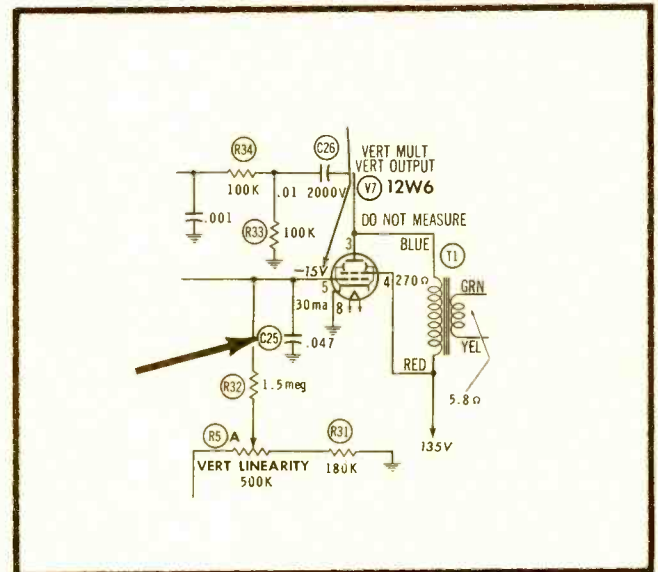

Mfr: Coronado Chassis No. S15

Card No: CO S15-3

Section Affected: Sync.

Symptoms: Vertical roll and horizontal tearing. Low voltage at pin 1 of V6A.

Cause: Leaky filter capacitor in plate circuit of sync separator.

What To Do: Replace C20 (820 mmf).

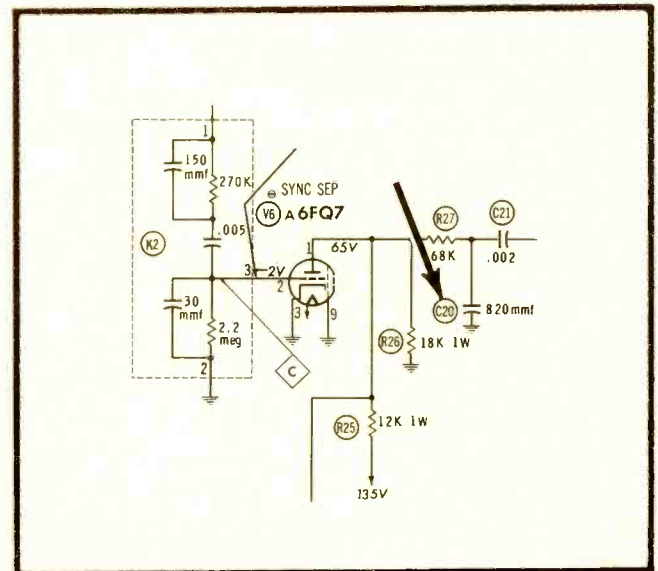

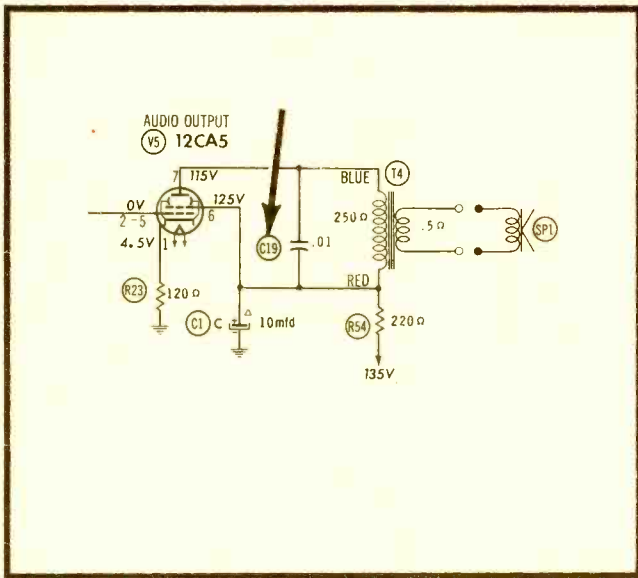

See PHOTOFACT Set 568, Folder 2

Mfr: Coronado Chassis No. S15
 Card No: CO S15-4
 Section Affected: Sound.
 Symptoms: No sound.
 Cause: Shorted bypass capacitor shunting T4.
 What To Do: Replace C19 (.01 mfd).

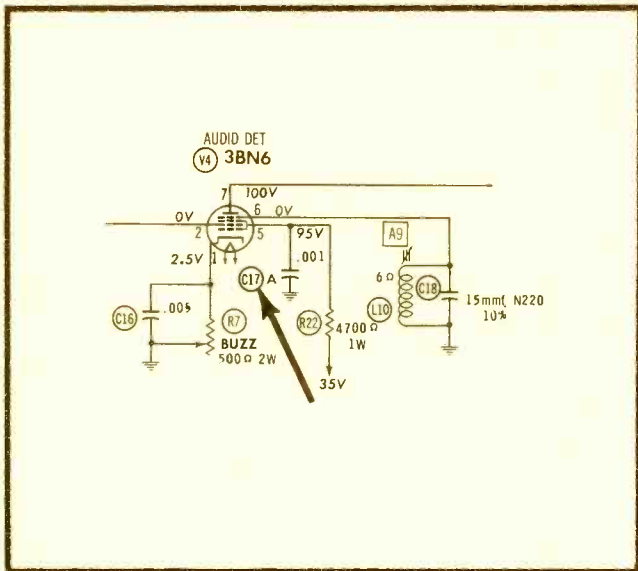

Mfr: Coronado Chassis No. S15
 Card No: CO S15-5
 Section Affected: Sound.
 Symptoms: Sound disappears after short period of operation. Low voltage on pin 5 of V4.
 Cause: Leaky bypass capacitor in screen circuit.
 What To Do: Replace C17A (.001 mfd).

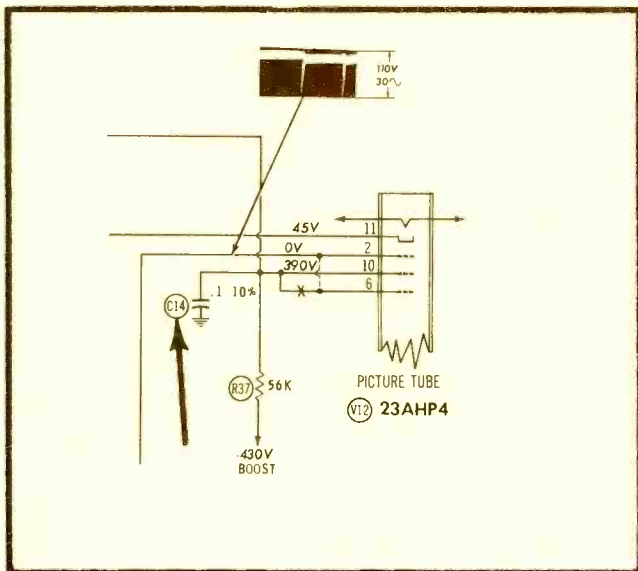

Mfr: Coronado Chassis No. S15
 Card No: CO S15-6
 Section Affected: Raster.
 Symptoms: No brightness. Low voltage at pin 10 of picture tube.
 Cause: Shorted bypass capacitor in CRT screen circuit.
 What To Do: Replace C14 (.1 mfd).

See PHOTOFACT Set 602, Folder 1

Mfr: Magnavox Chassis No. V38-01-00

Card No: MA V38-1

Section Affected: Raster.

Symptoms: Poor vertical linearity; bottom compressed, top stretched.

Cause: Open capacitor in cathode of vertical output tube.

What To Do: Replace C3 (100-20-100 mfd—350-350-50V).

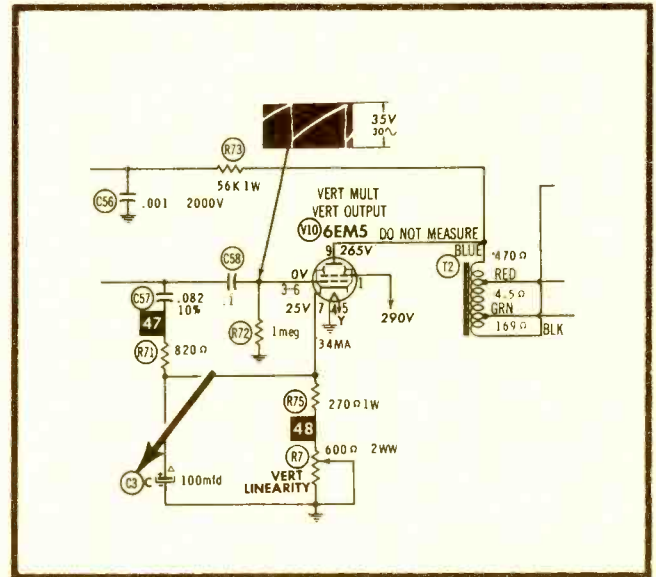

Mfr: Magnavox Chassis No. V38-01-00

Card No: MA V38-2

Section Affected: Raster.

Symptoms: Dull picture with insufficient brightness.

Cause: Shorted capacitor in vertical retrace blanking network.

What To Do: Replace C31 (.0033 mfd—2000V).

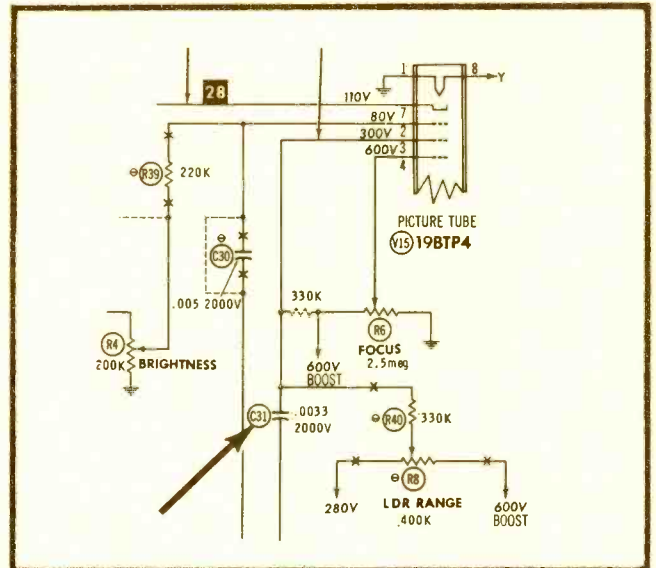

Mfr: Magnavox Chassis No. V38-01-00

Card No: MA V38-3

Section Affected: Sync.

Symptoms: Vertical rolling; unable to stop with hold control.

Cause: Leaky capacitor in sync output stage.

What To Do: Replace C51 (.002 mfd).

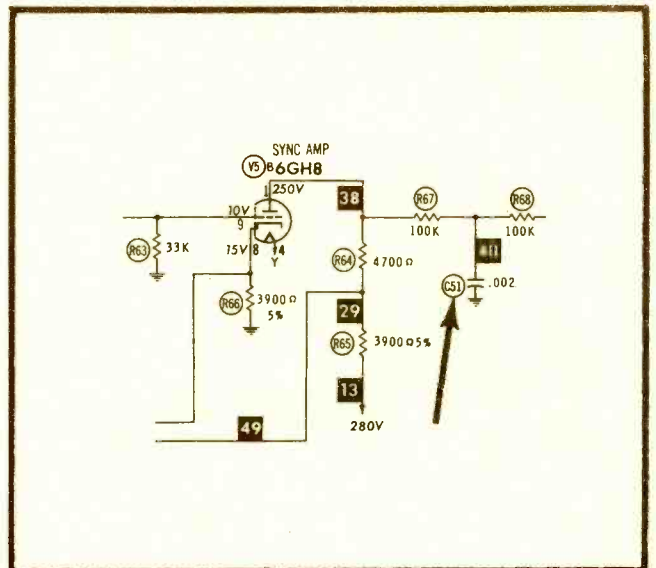

See PHOTOFACT Set 602, Folder 1

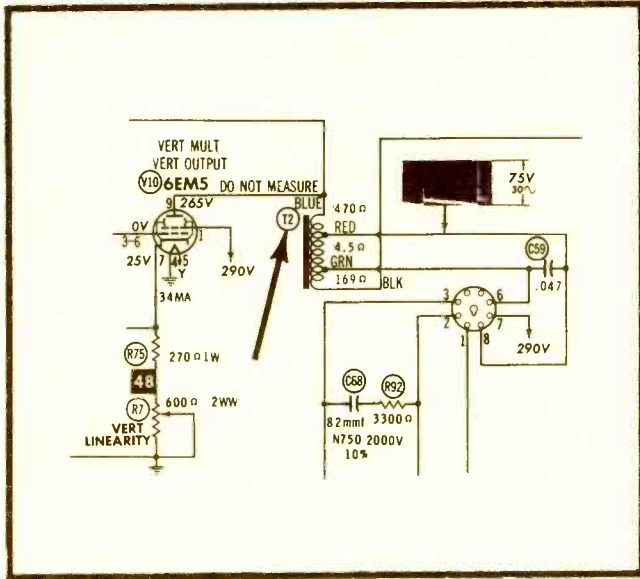

See PHOTOFACT Set 602, Folder 1

Mfr: Magnavox Chassis No. V38-01-00

Card No: MA V38-4

Section Affected: Raster.

Symptoms: No vertical deflection.

Cause: Shorted vertical output transformer.

What To Do: Replace T2.

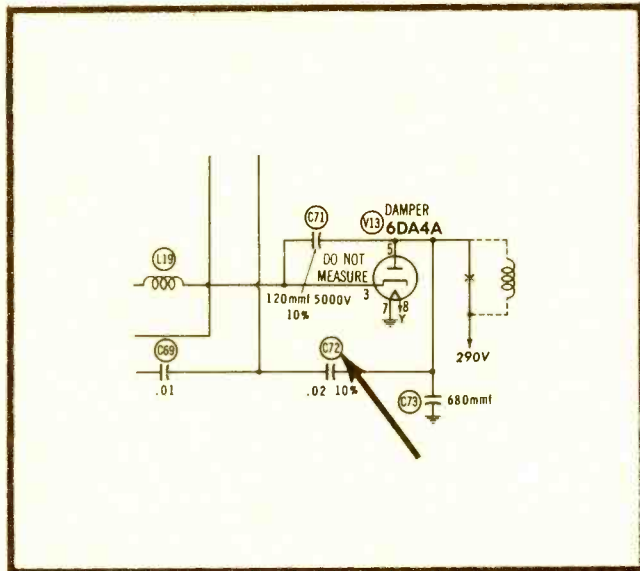

Mfr: Magnavox Chassis No. V38-01-00

Card No: MA V38-5

Section Affected: Raster.

Symptoms: Width of raster reduced to 2" strip; high voltage is weak.

Cause: Shorted capacitor in horizontal deflection circuit.

What To Do: Replace C72 (.02 mfd).

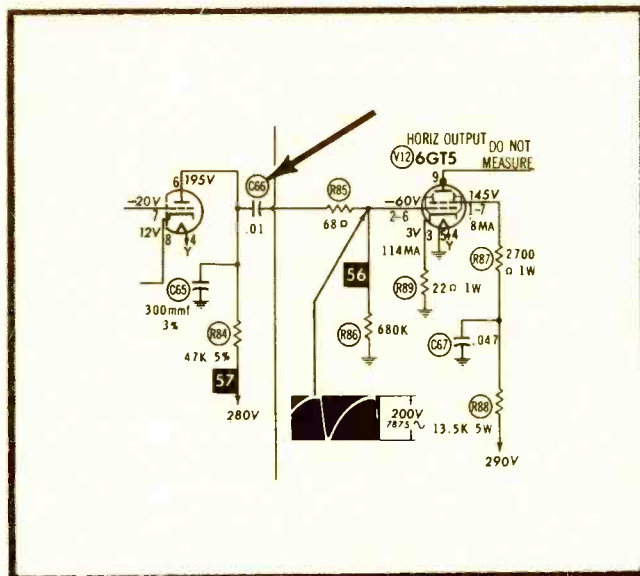

Mfr: Magnavox Chassis No. V38-01-00

Card No: MA V38-6

Section Affected: Raster and sync.

Symptoms: Insufficient width and loss of horizontal sync. Cathode current through V12 increases; negative grid voltage decreases.

Cause: Leaky coupling capacitor at output grid.

What To Do: Replace C66 (.01 mfd—1000V).

Tarzian offers
**FAST, DEPENDABLE
 TUNER REPAIR
 SERVICE (ALL
 MAKES)**

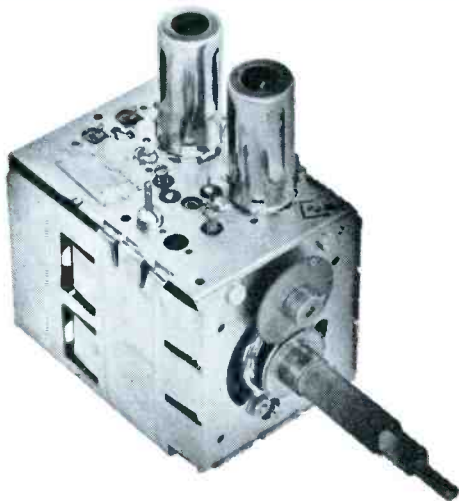

It just makes sense that a manufacturer of tuners should be better-qualified, better-equipped to offer the most dependable tuner repair and overhaul service.

Sarkes Tarzian, Inc. pioneer in the tuner business, maintains two complete, well-equipped Factory Service Centers—assisted by Engineering personnel—and staffed by specialized technicians who handle ONLY tuner repairs on ALL makes and models.

Tarzian-made tuners received one day will be repaired and shipped out the next. Allow a little more time for service on other than Tarzian-made tuners.

Tarzian offers a 12-month guarantee against defective workmanship and parts failure due to normal usage. And, compare our cost of \$9.50 and \$15 for UV combinations. There is absolutely no additional, hidden charge, for ANY parts except tubes. You pay shipping costs. Replacements on tuners beyond practical repair are available at low cost.

Ⓢ Tarzian-made tuners are identified by this stamping.

When inquiring about service on other tuners, always give TV make, chassis and Model number. All tuners repaired on approved, open accounts. Check with your local distributor for Sarkes Tarzian replacement tuners, replacement parts, or repair service.

 **SARKES TARZIAN, INC.**
 Bloomington, Indiana

MANUFACTURERS OF TUNERS . . . SEMICONDUCTORS . . . AIR TRIMMERS . . . FM RADIOS . . . AM/FM RADIOS . . . AUDIO TAPE . . . BROADCAST EQUIPMENT

ONLY
\$9.50
 INCLUDING

ALL PARTS
 (except tubes)
 and **LABOR**

**24-HOUR SERVICE
 1-YEAR WARRANTY**

**TWO SERVICE CENTERS
 TO SERVE YOU BETTER**

**See your distributor, or use the
 address nearest you for fast fac-
 tory repair service**

537 South Walnut St.
 Bloomington, Indiana
 Tel: 332-6055

10654 Magnolia Blvd.
 North Hollywood, Calif.
 Tel: 769-2720

Circle 2 on literature card

Which TV Rotor is your best buy?

Compare all three!

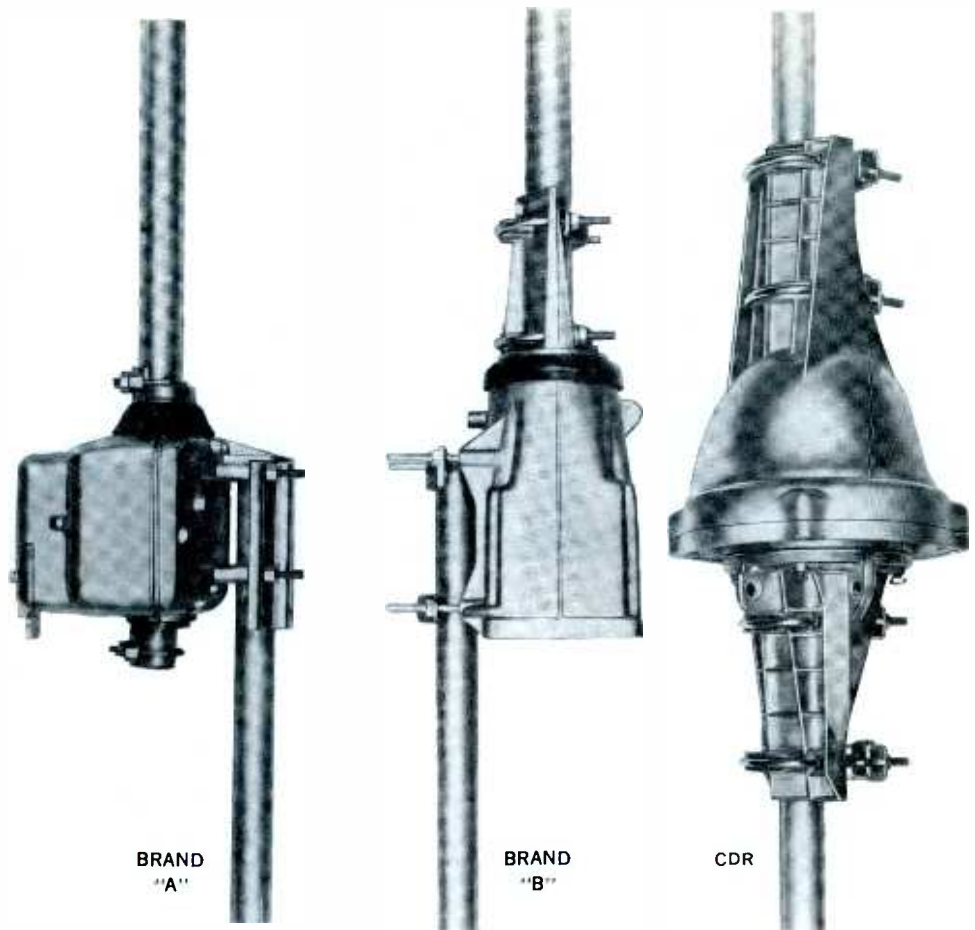

Motor	Low Voltage, light duty	Light duty, thinnest gears	Heavy duty
Stall Torque*	115 in. lbs.	75-112 in. lbs.	525 in. lbs.
Brake Torque*	Exceeds stall torque	Exceeds stall torque	435 in. lbs.
Rotation Time* (360°)	60 sec.	60 sec.	45 sec.
Housing	Cast zinc	Thin die-cast alum.	Heavy re-inforced die-cast alum.
Weather Sealing	Flexible neoprene boot	Flexible neoprene boot	Weather-proof bell casting
Thrust Bearing	Small, dead weight collars	Light-weight shaft support	Heavy duty 6½" dia. ball-bearing
Extra-Cost Thrust Bearing Access.	Available	Available	Not required
Gear Arrangement	Alum. worm	Light spur & pinion	Heavy spur & pinion
Mounting Design	Offset	Offset	In-Line, symmetrical
Mast or Tower Mounting	Yes (with Tower adaptor)	Yes (with Tower adaptor)	Yes (no adaptor req.)
Compensating Rheostat on Meter Models	Yes	No	Yes
Positive Synch on Auto Model	Yes. 10° steps	No (dependent on motors)	Yes. 6° steps
Auto. Model Out-of-Synch Indicator	Yes	No	Yes
Compass Indicating-Light Model	Not available	Not available	Available
Thermal Protector	Yes (secondary circuit)	No	Yes (primary circuit)

*Based on CDE engineering laboratory tests of purchased samples.

You've compared. Doesn't a "gutsier" CDR rotor make sense?

Rugged. Durable. Weatherproof. Sturdy.

People may think we overdesign our rotors. We don't. It's our way of making sure you and your customers get everything they expect in a fine rotor. And more.

A CDR costs more than most. But we think this initial cost pays off. Your customers will, too.

They get the benefit of the finest, most reliable rotor on the market.

They'll have even more confidence in you. Helps cement your relationships with them.

You're less likely to waste time and money on unpaid re-calls.

Now that makes sense.

Another thing that makes sense is our complete antenna/rotor merchandising package. It includes a 16-page consumer booklet, descriptive literature, and other sales aids. Write for it. Cornell-Dubilier Electronics, Division of Federal Pacific Electric Company, 50 Paris St., Newark, New Jersey 07101.



Circle 3 on literature card

publisher
Howard W. Sams

general manager
Mal Parks, Jr.

executive editor
Verne M. Ray

editor
Forest H. Belt

associate editors
George F. Corne, Jr.
Patrick M. Craney

consulting editors
William E. Burke
Joe A. Groves
C. P. Oliphant

production manager
Robert N. Rippy

circulation manager
J. A. Vitt

circulation fulfillment
Pat Tidd, Mgr.
Katherine Krise, Ass't.
Cara La Von Willard, Ass't.

art directors
Gene La Rue
Robert W. Reed

advertising & editorial assistants
Gladys Bauer
Georgeanna Caldwell
Rebecca Clingerman
Clare Hull

photography
Paul Cornelius, Jr.

advertising sales offices
Dave Milling, advertising sales manager

midwestern
Hugh Wallace
PF REPORTER
4300 West 62nd Street,
Indianapolis 6, Ind.
AXminster 1-3100

eastern
Gregory C. Masefield
Howard W. Sams & Co., Inc.
3 West 57th Street,
New York, N. Y.
MUrray Hill 8-6350

western
The Maurice A. Kimball Co., Inc.
2550 Beverly Blvd., Los Angeles 57, Calif.
DUmkirk 8-6178; and 580 Market Street,
Room 400, San Francisco 4, Calif. EXbrook 2-3365

Address all correspondence to
PF REPORTER, 4300 W. 62nd Street,
Indianapolis 6, Indiana



Copyright © 1964 by Howard W. Sams & Co., Inc.
PF REPORTER is a trademark of Howard W. Sams & Co., Inc. No part of PF REPORTER may be reproduced without written permission. No patent liability is assumed with respect to use of information herein. Acceptance of advertising does not in any manner signify the products, policies and services so advertised have been approved, endorsed or recommended by this magazine.
Subscription Prices: 1 year—\$5.00, 2 years—\$8.00, 3 years—\$10.00, in the U.S.A., its possessions and Canada.
All other foreign countries: 1 year—\$6.00, 2 years—\$10.00, 3 years—\$13.00. Single copy 50¢; back copies 65¢.

Indexed in *Lectrodex*.
Printed by the Waldemar Press Div.
of Howard W. Sams & Co., Inc.



PF REPORTER

including **Electronic Servicing**

VOLUME 14, No. 2

FEBRUARY, 1964

CONTENTS

Special Cover Feature	
Servicing Procedures For TIS* Larry Allen	30
*Transistorized Ignition Systems There's something new under the hood, and you may have the chance to service it!	
Previews of New Sets	1
General Electric Model M110YBG (Chassis SY)	
Motorola Model Y23K89 (Chassis TS-586)	
Panasonic Model Mitey-9	
RCA Model 64A030 (Chassis KCS-146)	
Video Speed Servicing	5
Service hints on Coronado Chassis S15 and Magnavox Chassis 38	
Letters to the Editor	12
The Electronic Scanner	14
The Troubleshooter	18
Wire and Cable Stock Guide	20
Symfact: Video Amplifier With ABC (Automatic Brightness-Contrast Control)	25
See what happens to voltages and waveforms when troubles occur.	
An Inside Look at Synchroguide Allan F. Kinckiner	32
Shop Talk—Quite an evolution has taken place in this circuit over the years.	
New AFC Systems for FM Larry J. Ritorto	34
You'll find unusual new components controlling the oscillator.	
Color Chassis or CRT? Carl Babcoke	36
Bad picture tube? Don't be too sure! Check these faults first.	
Facts About Filter Capacitors Rufus P. Turner	38
Working voltage, leakage current, and power factor, are key considerations.	
You Can Manage For Profit Forest H. Belt	46
Dollar and Sense Servicing—These fresh business practices can bring you more dollars than your technical ability.	
Notes on Test Equipment Stephen Kirk	54
Lab reports on the ECI Port-A-Lab CB Transmitter Tester and Mercury Model 501 Component Substitutor.	
Product Report	78
Free Catalog & Literature Service	80
Monthly Index on free literature card	

ABOUT THE COVER

Any day now, a customer may drive his car to your shop, park it, and ask for service. However, you'd better ask what needs repair—it may not be his radio! If he replies "ignition system," you'll need the up-to-date service information on page 30.



NEW FROM ATR

ATR

ALL-TRANSISTOR MODEL 707 Karadio®

"the oldest name in radio"



Suggested \$**29.95**
Retail Price

... for those who want the finest! Check the features of this all-new, all-transistor Model 707 Karadio by ATR... features galore that make sales easier, keep users happier! Compare... and without hesitation place your order NOW for the new all-transistor ATR Karadio.

- Large easy-to-read illuminated dial.
- Finger-tip tone control to adjust tone as you desire
- 7-tuned circuits including RF stage to provide maximum sensitivity and selectivity.
- Automatic volume control to keep signals strong and steady
- Utilizes "solid state" construction employing 7 semi-conductors (5 transistors and 2 diodes).
- Superheterodyne circuit.
- 3-Section Super "Magna-Wave" tuner.
- Hand wired. No printed circuitry.
- Has one-piece self-contained chassis for easy installation.
- "Fits-All" universal construction. For use with practically all import and American cars and trucks.
- Fits under-dash or in-dash utilizing standard trim plate kits.
- Comes complete with built-in speaker.
- External speaker jack provided.
- Available for 12-volt negative ground installations only.
- Low battery drain.

Neutral Gray-Tan baked enamel finish. Overall size approximately 5 1/2" deep x 6 1/2" wide x 2" high. Shipping Weight 5 lbs.

SEE YOUR ELECTRONIC PARTS DISTRIBUTOR
WRITE FACTORY FOR FREE LITERATURE . . .

ATR ELECTRONICS, INC.
Formerly: American Television & Radio Co.

ATR
Quality Products Since 1931
ST. PAUL 1, MINNESOTA—U.S.A.

Circle 4 on literature card

Letters to the Editor

Dear Editor:

I had just sewed up a service job on an Admiral Chassis 21G4 when your November, 1963 issue arrived. Lo and behold, right there in *Symfact*—Symptom 4—was exactly the same trouble I had just found. I had very little trouble spotting C1 as the culprit, but I did notice there is no C1 in the *Symfact* schematic. The capacitor I removed from the set was shorted, but *your* C1 most certainly was open!

Please don't think me a complainer; I got a kick out of the whole situation. I enjoy every moment I spend reading PF REPORTER; *Symfact* has saved me a lot of time in the past, and I hope you continue this wonderful service adviser.

W. W. MILLER SR.

Philadelphia, Pa.

Dear Editor:

Symfact is terrific, even with an occasional error. In your November issue, I've even considered the possibility that the omission of C1 was added color for your color issue.

Do you see one C1?

ROBERT G. LEMAY

Clinton Sherman AFB, Okla.

Either the C1 symbol or the author's mind "came unstuck" at a critical moment. But there really is a C1 in the circuit; please sketch in a .0062 capacitor from lead 1 of M1 to ground.—Ed.

Dear Editor:

The little column on telephone etiquette (page 86, November issue) amused me. I always answer my phone with "Hello, Bill White speaking," and I usually get the response "May I speak with Bill White, please?" or "Hello, Bill?" You figure them out!

BILL WHITE

Princeton, Fla.

Who says there's no market for a telephone with a built-in TV screen?—Ed.

Dear Editor:

None of the *Symfact* articles between October, 1962 and June, 1963 mentioned the trade name and chassis number of the TV set covered by each article. Could you supply me with these numbers so I can make a complete index to *Symfact*?

JACK S. MINCH

Absecon, N.J.

Okay, here goes:

- Oct. Motorola Chassis TS-570
- Nov. Wells-Gardner Chassis S17
(use PHOTOFACT Folder 610-1)
- Dec. Same as Nov.
- Jan. Symphonic Model 19P2A
- Feb. Trav'ler Chassis 1096-242
(use PHOTOFACT Folder 624-3)
- Mar. Zenith Chassis 16K26
- Apr. Philco Chassis 13J42
- May Muntz Model 7310M (27")
- Jun. Zenith Chassis 14K20

—Ed.

NEW CONTACT CLEANER



Jif

FORTIFIED with SILICONE NOT HARMFUL TO PLASTIC!

JIF away dust, dirt and corrosion on contacts, switches, controls with this NEW siliconized cleaner. JIF cleans and lubricates, providing contacts and controls with the longest possible protection. Fast and efficient, JIF saves time and money. CLEAN — LUBRICATE — PROTECT. Safe, quick-easy to use—JIF won't harm plastics.

Part No.	Net
8670-6 New 6 oz. spray can	1.79
8670 New 3 oz. Pocket size spray can	.99

NEW CATALOG
JUST OFF THE PRESS
GC CATALOG FR-65
WRITE TODAY!

GC ELECTRONICS CO.
400 So. Wyman St., Rockford, Ill., U.S.A.

Circle 5 on literature card

NOW

YOU CAN AFFORD TO SERVICE COLOR TV!

NEW — LOW COST INSTALLER'S COLOR TV GENERATOR, a product of 10 years' know-how in color test equipment. Built around a completely new circuit approach, the Model 662 Generator sets a new standard of convergence accuracy. Every feature of this instrument adds up to better performance, more time saved and larger profits.

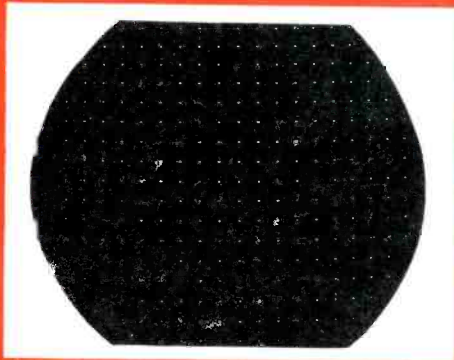

500 dot system means no blank areas —entire screen is covered. Dots are one line thick, less than two lines wide.



Exclusive, crystal-controlled color-burst bar to trouble shoot, check alignment and hue control, set demodulator.

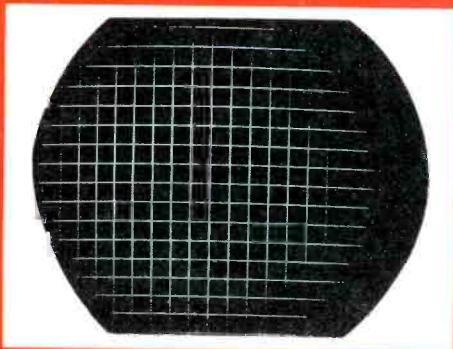

Choice of vertical bars, horizontal bars or crosshatch to speed dynamic convergence. 25 horizontal lines, 20 vertical lines.

This entirely new approach to color generation uses a color bar at burst phase and frequency (3.579545 ±10 cycles). With this feature, you can instantly check overall color performance, chroma circuits, demodulator alignment and hue control range. Obsolescence-proof because the color bar is at burst phase and frequency. It works on R-Y/B-Y, G-Y and X/Z systems . . . or any other!



Model 662

HICKOK

See the new Model 662 and other Hickok color equipment at your Hickok distributor now.

THE HICKOK ELECTRICAL INSTRUMENT CO.

10566 Dupont Avenue • Cleveland, Ohio 44108
 Represented in Canada by Stark Electronics, Ajax, Ontario
 Internationally by Hughes International, Husint, S. A., Culver City, Cal.



677
Wide Band Oscilloscope

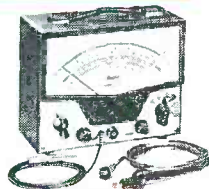

470A
Uni-scale VTVM



800A
Portable Tube, Transistor Diode Checker



661
Color Bar Generator

Circle 6 on literature card

NOW! CASTLE OFFERS YOU THE BIGGEST BARGAIN IN TV TUNER OVERHAULING!

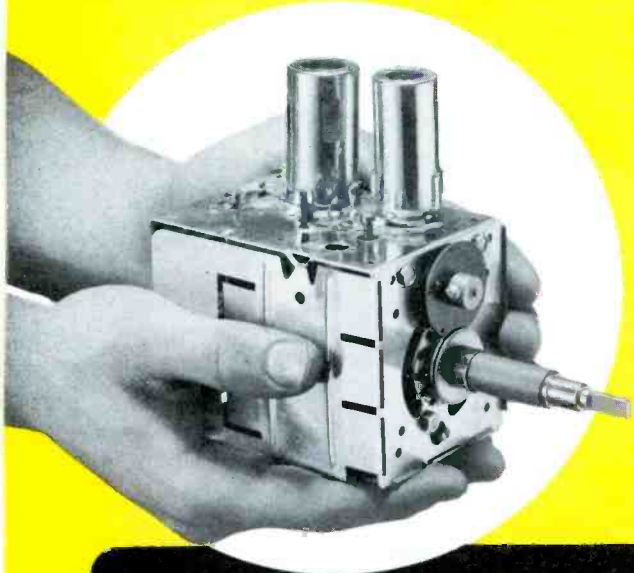

**ALL MAKES
ALL LABOR
AND PARTS
(EXCEPT TUBES)*
ONE PRICE**

995

THIS ONE LOW PRICE INCLUDES ALL UHF, VHF
AND UV COMBINATION* TUNERS

In a decade of experience overhauling TV Tuners of ALL MAKES, Castle has developed new handling and overhauling techniques which give you . . .

Fast Service

A recent study at our Chicago Plant revealed that of all tuners accepted for overhauling, over 30% were completed and shipped within . . . **Seven Hours** . . . all others within 24 Hours.

Simply send us your defective tuner complete; include tubes, shield cover and any damaged parts with model number and complaint. 90 Day Warranty.

Exact Replacements are available for tuners unfit for overhaul. As low as \$12.95 exchange. (Replacements are new or rebuilt.)

*UV combination tuner must be of one piece construction. Separate UHF and VHF tuners must be dismantled and the defective unit only sent in.

Pioneers in TV



Tuner Overhauling

CASTLE

TV TUNER SERVICE, INC.

5701 N. Western Ave., Chicago 45, Illinois
653 S. Palisade Ave., Cliffside Park, New Jersey
Canada: 136 Main St., Toronto 13, Ontario

*Major Parts are additional in Canada

Circle 7 on literature card



The Electronic Scanner

news of the servicing industry

EIA Elects Officers

Norman A. Triplett, Marketing VP for **Triplett Electrical Instrument Co.**, was elected chairman of the new Distributor Products Div. of the Electronic Industries Association. Chosen as vice chairman was Thomas Ure, VP of Sales for **Hardwick, Hindle, Inc.** Mr. Triplett, Mr. Ure, and Mr. Jack D. Hughes, Executive VP of **Littlefuse Inc.**, will represent the division on the EIA board of directors.

Radar Protects Thruway



A radar antenna, on the mast at left, looks out over the world's longest causeway spanning the 24-mile-wide Lake Pontchartrain near New Orleans, Louisiana. **Raytheon** radars and marine radio-telephones have been installed at the two bascule bridges eight miles out from each shore where ships cross the roadway. To safeguard motorists who "go to sea" in their cars in foggy weather, causeway personnel keep an electronic lookout for loose barges or disabled vessels that might stray from regular ship channels and drift towards the bridge. Using their radios, the bridge tenders can call the Coast Guard or other agencies to recover drifting barges, or they can warn the skipper of a wayward vessel.

"Something Old . . ."

Sony Corp. of America is collecting antique communications devices, giving a new transistor radio in exchange for each. Although it is sometimes difficult to decide just what is or isn't a communications device, items such as old earphones, telephones, typewriters, and radios are among those most readily accepted.

\$3 Million Plant Going Up

International Telephone and Telegraph Corp. has made plans to construct a \$3 million integrated-circuits and semiconductor plant in West Palm Beach, Fla. The new 135,000-square-foot structure will be under the management of **ITT Semiconductors, Inc.**, and is expected eventually to employ 500 persons. The one-story plant, scheduled for completion sometime in February of 1964, will be air-conditioned, and constructed of glass, concrete, and brick.

Rep of the Year

The **Be-Esco Sales Corp.** of Yonkers, New York, has received **Jerrold's** Distributor Sales Division's annual "Representative of the Year" award, according to **Walter Goodman** of **Jerrold Goodman**, in making the announcement, cited **Be-Esco** as "having made one of the most outstanding sales accomplishments of this or any other year."

New Sales and Advertising Director



Sidney T. Kitrell has been advanced to the post of Director of Sales and Advertising at **Hy-Gain Antenna Products Corp.** Mr. Kitrell, who has been Sales Manager of **Hy-Gain** for the past 4 years, is widely known throughout the industry.

you get **PRODUCT PLUS** from your *Sylvania Distributor*

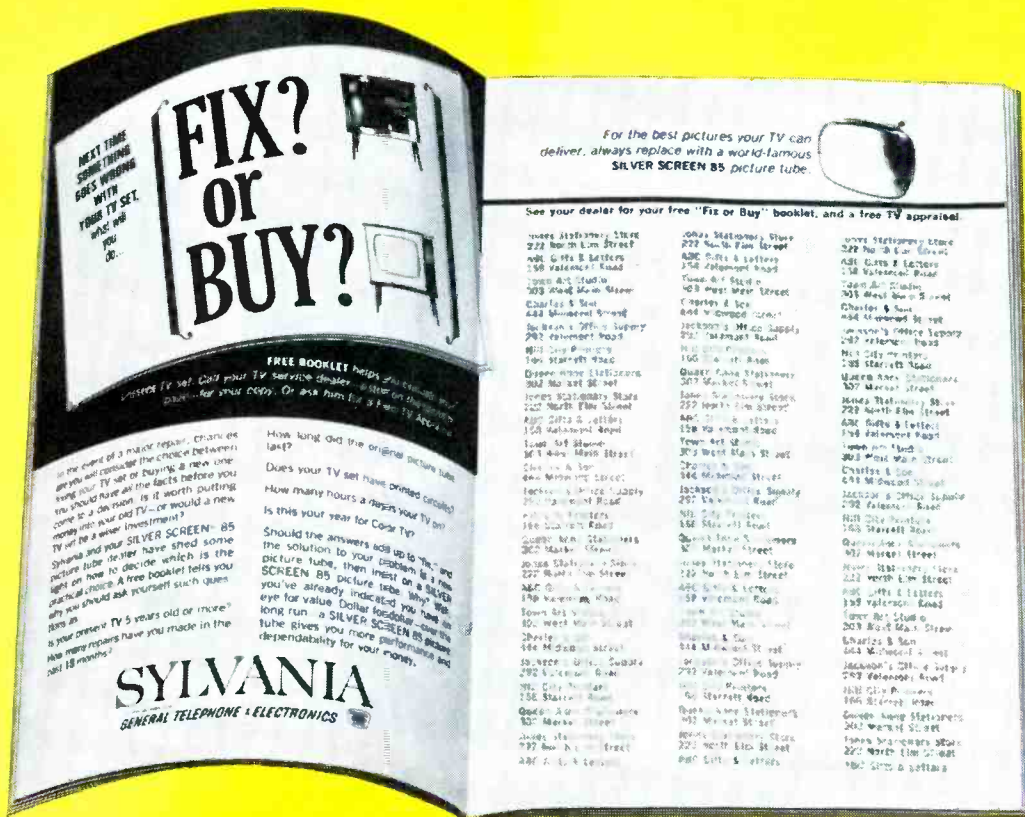

Was your name part of this hard-sell ad in



If you took advantage of the offer, February 8th TV Guide tells every reader in your neighborhood that you are the expert on whether they should repair or replace their TV set. And a helpful free booklet titled "Fix or Buy?" is in your hands for distribution free to your customers. ■ National advertising in TV Guide, the booklet, plus a banner advertising the booklet for your store—a triple-barreled way to hit your very best prospects. ■ Specials like this are available regularly through your participating Sylvania Distributor. They show that he is sincerely concerned with raising your profits and your prestige—and so is Sylvania. ■ You can expect more than the highest-quality tubes when you deal with your Product-Plus Sylvania Distributor.

SYLVANIA
SUBSIDIARY OF
GENERAL TELEPHONE & ELECTRONICS

Circle 8 on literature card



**With SPRAGUE you get EVERYTHING ...
 ...no other Capacitor Line even comes close!**



HUNDREDS of
SPRAGUE
DISTRIBUTORS
EVERYWHERE

TOPS
IN
AVAILABILITY

NO
SKELETON
LINES!

Your Sprague Distributor is
your **ONE-STOP** Capacitor Center

BANG

Replacement
Manuals

SPRAGUE Helps YOU
CHOOSE and USE
CAPACITORS
CORRECTLY

Easy-to-read
Catalogs &
Bulletins

Color-Code
Calculators

With **SPRAGUE**
you get **EVERYTHING**

huchnergarth

Sprague's latest capacitor catalog, which lists thousands of replacement capacitors for practically every application, is just off the press. Get your copy of Catalog C-615 from your Sprague Distributor, or write to Sprague Products Company, 105 Marshall Street, North Adams, Mass.

Circle 9 on literature card

SPRAGUE®
THE MARK OF RELIABILITY®

BUSS Sub-Miniature PIGTAIL TRON FUSES

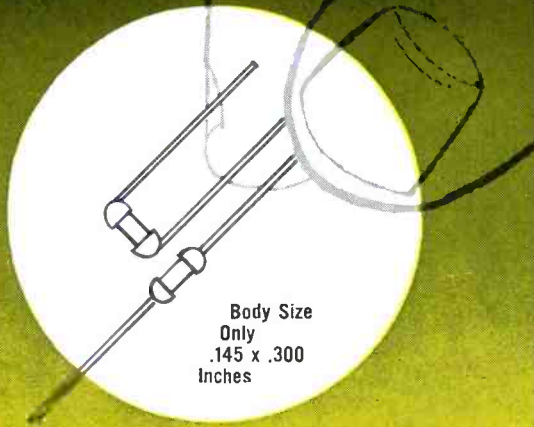

Body Size Only
.145 x .300
Inches

Tron fuses are so small they can be used as an integral part of circuit—to protect miniaturized devices—or gigantic multi-circuit electronic devices, without sacrifice of space.

They are hermetically sealed for potting without danger of sealing material affecting operation and have high resistance to shock or vibration. Operate without exterior venting. May be teamed with other components in replaceable unit.

BUSS

Write for BUSS Bulletin SFB.

BUSSMANN MFG. DIVISION, McGraw-Edison Co., St. Louis 7, Mo.

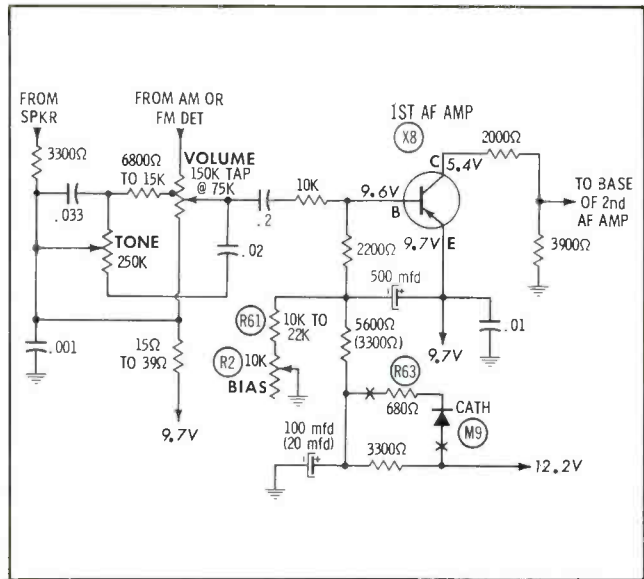

Assuming the first audio stage is faulty, you should be looking for some condition that causes blocking of this stage during the initial short period of operation. The main suspects are bias control R2 and its series resistor R61, which serve as part of a voltage divider to set the correct base voltage. If this leg of the divider should become temporarily open, the base would simply be returned to the 12.2 volt source; since that point is at a higher positive potential than the emitter, the B-E junction would be reverse biased, and transistor X8 would be held in cutoff.

Another possibility is that the circuit might have an intermittently open connection that is breaking the normal discharge

BUSS: 1914-1964, Fifty years of Pioneering....



The Troubleshooter

answers your servicing problems

The Pause That Mystifies

An all-transistor FM-AM auto radio, Ford Model F3TBF (PHOTOFACT Vol. AR-20) has a strange intermittent problem. The first time it is switched on after a long idle period, it will start to play instantly; but if it has been off for only a short time, it will not begin to play for 10 seconds. During this interval of waiting, the signal can be traced through the RF and IF stages, but is lost at the volume control. In addition, many voltages in the audio stages are more positive than normal, but these do not definitely pinpoint the trouble. I have checked and substituted most of the audio components without curing the complaint.

THOMAS R. RANDALL

Tilton, Ill.

Your signal-tracing check strongly suggests trouble in the input circuit of the first audio amplifier. Certainly this circuit (shown in schematic) contains plenty of potential trouble spots! Just to make sure you have correctly localized the fault, try injecting a signal into the base of the second audio amplifier during the delay period; if the diagnosis is right, you'll hear normal sound from the speaker.

TO HELP MAKE FUSE HANDLING MORE PROFITABLE...



BUSS VISUAL-PAK

CLEAR PLASTIC BOX,
THERE'S NO NEED
TO OPEN
TO SEE HOW MANY
FUSES ARE
IN IT

- BUSS fuse 5-in clear plastic box—let's you check fuses in each box at a glance... guards against running short on needed fuses.
- Size and style of fuses printed in large type on lid of box makes it easier to pick out fuses you want.
- Box fits all fuse display stands and channels.

BUSS

PIONEERING NEW DEVELOPMENTS IN ELECTRICAL PROTECTION SINCE 1914

BUSSMANN MFG. DIVISION, McGraw-Edison Co., St. Louis 7, Mo.

Circle 10 on literature card

BUSS Sub-Miniature FUSE-HOLDER COMBINATION



A light weight, protective device for space-tight applications in multiple circuit apparatus. Fuse has transparent window for visual inspection of element. Fuse may be mounted alone or used in holder on printed circuit boards.

HWA holder can also be panel mounted with or without use of knob. Knob makes holder water proof for front of panel.

BUSS

For full details write for BUSS bulletin SFB

BUSSMANN MFG. DIVISION, McGraw-Edison Co., St. Louis 7, Mo.

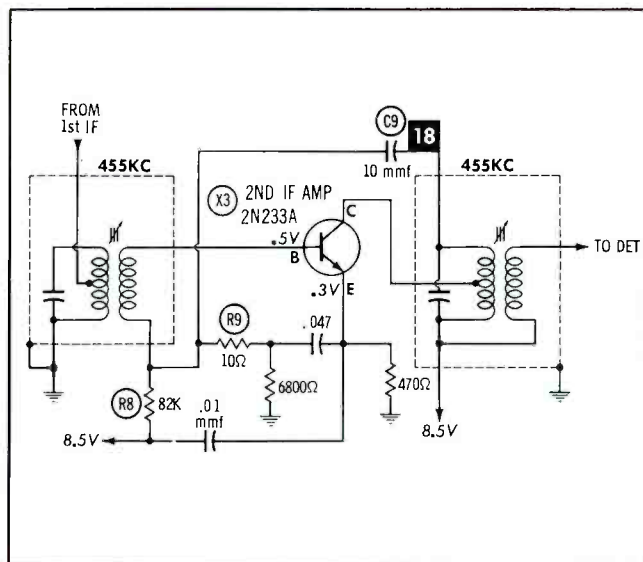

2. Carefully check components in the emitter and base circuits of X3 to be certain the transistor is correctly biased.
3. Try changing the value of neutralizing capacitor C6; temporarily installing a trimmer will help you find the optimum value.
4. If the oscillation is still present, try a new transistor; the original unit may be an unusually "hot" one that provides excessive gain.

The parts values shown in the schematic apply to radios using a 2N233A transistor in the second IF stage. Certain production runs contained a 2N169 transistor; in this case, C9 and R9 were omitted, and the value of R8 was 47K.



....New Developments in Electrical Protection

path of a capacitor, causing it to retain a charge and block X8 for several seconds. The bad connection might be on the printed board; if so, you can find it by flexing and probing the area of the board near X8.

Another suspect is the 9.7 volt branch of the power supply. If some defect in another section of the set is overloading this branch and reducing the source voltage during the delay period, the emitter voltage of X8 may become less positive than the base voltage—reverse biasing the transistor into cutoff.

Note that the values of several resistors in the base-bias circuit have been selected to match different transistors; this gives a clue that judicious changes in value may correct the trouble. However, be very careful about increasing the forward bias between base and emitter—make sure the collector current stays within safe limits.

R63 and M9 are included in some sets for the purpose of eliminating noise that originates in a car's air-conditioning system. If these components are present in this particular set, check their effect on the bias of X8.

Squealer

A General Electric Model P-755-A transistor radio (PHOTOFACT Folder 447-6) has the "squeals." The trouble can be stopped by touching *CircuitTrace* point 18 with a finger, or by reducing the supply voltage. When the chassis is out of its case, moving it around causes a zero-beating effect.

RICHARD DONLEY

Erial, N.J.

The second IF amplifier stage is evidently oscillating. There are several measures you can take to improve the stability of this circuit:

1. Make sure the IF transformers are tuned exactly to 455 kc.

Let BUSS Fuses Help Protect Your PROFITS

To make sure BUSS fuses will operate as intended under all service conditions, each and every BUSS fuse is individually tested in a sensitive electronic device.

This is your assurance that when you sell or install BUSS fuses, you are safeguarded against complaints, call-backs and adjustments that might result from faulty fuses and eat away your profit.

It is just good business to sell fuses the BUSS way.

BUSS

Write for BUSS Bulletin SFB.

BUSSMANN MFG. DIVISION, McGraw-Edison Co., St. Louis 7, Mo.

Circle 10 on literature card

WIRE & STOCK GUIDE CABLE

Some shops go overboard on wire inventory. They purchase several kits—each containing different wire sizes—and replenish as necessary. Invariably, however, a few wire sizes are left unused over a period of time. To eliminate this waste, choose your wire stock wisely.

In determining the proper stock of wire and cable to keep on hand, the service technician should consider which types he uses most often. If his work consists mainly of radio and TV repair, he would be wise to stock various colors of solid and stranded hookup wire, some shielded audio cable, and a small quantity of high voltage wire. If he does a lot of phonograph work, he will need several different types of phono wire and cable.

Most Often Used Types

Shown in the chart is a checklist of the types of wire and cable used most often by the service shop. Specifications are given, but not quantities.

AC Line Cord

AC cord (called zip-cord and rip-cord) is used for making line cords and extension cords, wiring AC lines inside chassis, for ground buss

lines, etc. Heavy duty asbestos-covered cord is a good item if you service toasters, irons, and other small appliances.

Antenna Lead-In

No TV shop should be without 300 ohm twinlead. Some may even want to stock 72 ohm coaxial cable for use with antenna systems in areas of high interference. In addition, where Citizens band or commercial two-way radios are serviced, you will generally want to stock RG/8U and RG58/U 50 ohm coaxial cable.

Audio Coaxial Cable

The most common high-impedance type uses a single #20 or #22 conductor, with no insulation over the outer shield. It is small and flexible, and easily snaked into tight corners, yet durable enough to withstand heat and stress.

CRT High Voltage Wire

A roll of high voltage wire is necessary to have on hand for the replacement of defective second anode leads. Conductors of #20 or

#22 stranded wire will suffice, if insulation rating is at least 30 kv.

Hookup Wire

General purpose hookup wire is a "must" for every shop. It is difficult to categorize the many uses for this type of wire, since it is used in practically every type of electronic equipment. Some technicians like different colored wires for different circuits—e.g., brown or yellow wire for filaments, and red for B+. For general purposes, it is okay to use a #20 stranded wire with plastic insulation. Where heat is a problem, double-silk-covered wire will last longer.

Microphone Cable

This isn't always a "must" item, but you'll need it if you service tape recorders, PA amplifiers, musical instrument pickups, or transmitters. Single-conductor cable, similar to the audio type already mentioned, is used in high-impedance applications. Two conductors, well insulated and surrounded by a single shield, are used in low-impedance mike cables for long runs.

Test Lead Wire

If you use test equipment a lot, keep a few alligator clips and some test lead wire handy. Broken test leads can result in time lost going to the distributor for another. The wise technician takes a couple of minutes to make a new one. The wire for this purpose is especially flexible and well insulated.

Tone Arm Wire

With all the phonographs in existence today, you can hardly avoid being approached with phono repair work. Although tone arm wire doesn't need replacing too often, when it does, there's no substitute for it. It is very tiny and flexible, and is available as a twisted pair, three wires twisted together, sometimes surrounded by a metal shield, and as four separate, twisted wires. ▲

Table 1. Wire and Cable Stock Guide

	size	conductors	stranded	twisted	shielded	insulation
AC zip cord	18	2	X			rubber
antenna lead-in	300 ohm	2	X			plastic
audio coax	20	1	X		X	rubber
CRT HV wire	22	1				phenolic
hookup wire	20	1	X			coded plastic
microphone cable	18	2	X		X	
wire shielding						
spaghetti						
test prod wire	18	1	X			flexible
tone arm wire	20	2, 3, or 4	X	X		plastic

An aerial photograph of a winding road through a forested area. A large, complex metal antenna structure is mounted on a truck at the bottom of the frame. The structure consists of a tall lattice tower and several horizontal arms, each ending in a large, rectangular antenna element. The background shows a blue sky and a winding road that curves through a green, hilly landscape.

FINCO'S

*9 Mobile Research Units
have traveled over
3,000,000 miles to conduct
13,833 "side-by-side"
performance tests
with competitors*

*The **FINCO**® TV
Antenna is
always best!*

Want Proof?

*See your **FINCO** Distributor or write us.*

**THE
FINNEY
COMPANY**
Bedford
Ohio

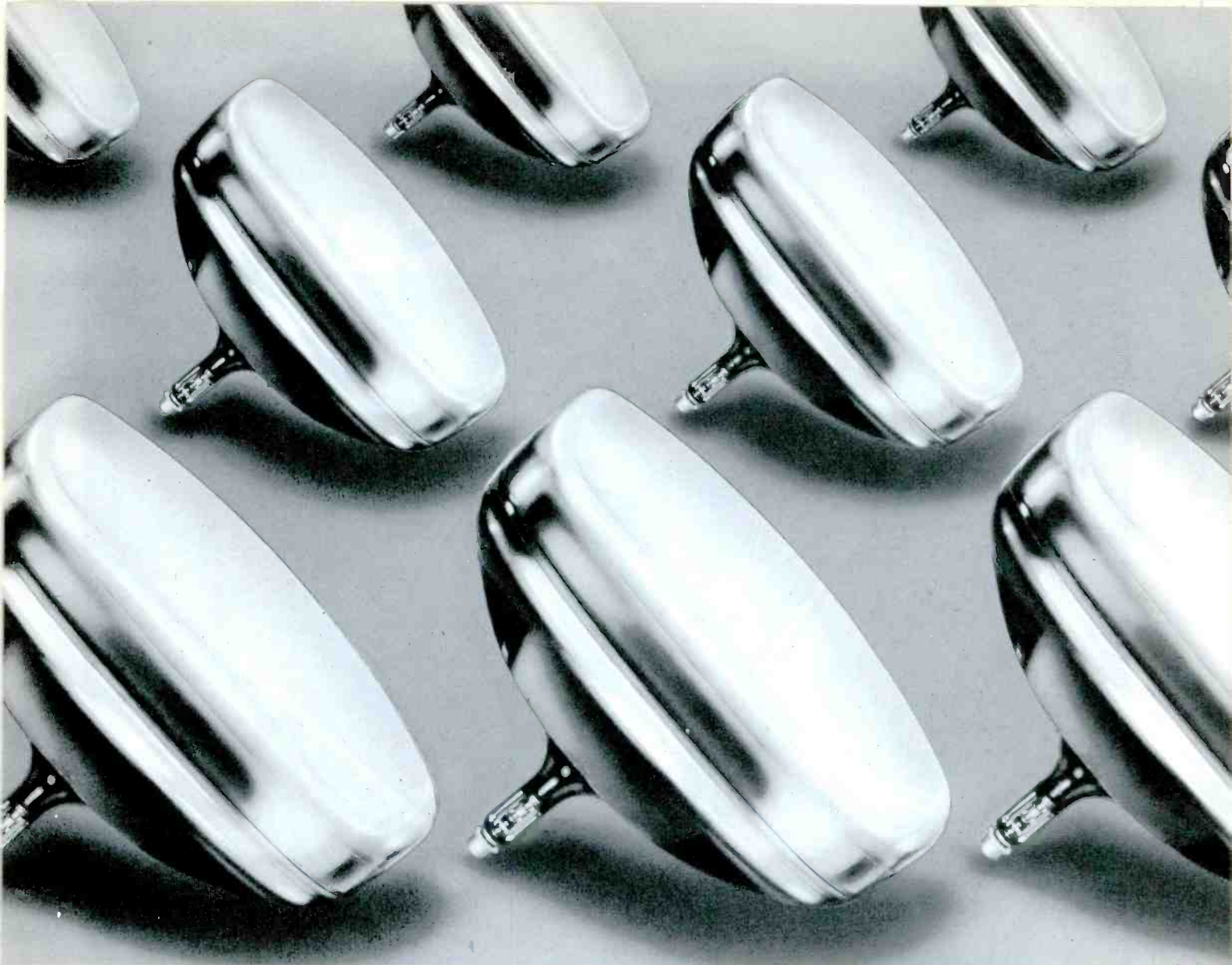

THE QUALITY OF YOUR SERVICE DEPENDS ON THE PARTS YOU USE...DEPEND

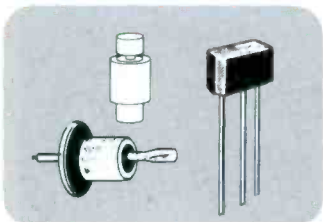

Diodes, Rectifiers, Condensers and Resistors
Complete variety for all makes and models.

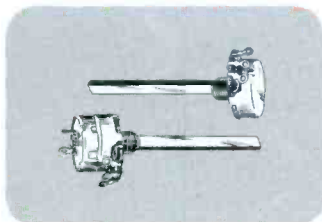

Universal Controls
With or without on-off switch. Standard taper, 3 inch shaft, half flat. 1 meg, 2 meg, 500 K. Complete selection. Fit Philco and other makes.

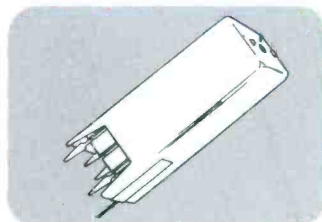

I.F. Transformers
For printed circuits, 4 lug, 5 lug or 6 lug types . . . to fit Philco or other makes. Dependable Philco Quality.

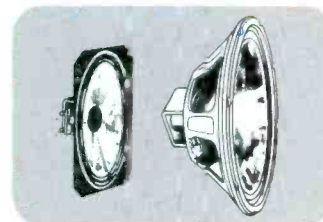

Replacement Speakers
All sizes, round, oval or rectangular types. 3.2, 8, 15, 20 cms. From tiny 1 3/4" to giant 15" sizes.



Philco Receiving Tubes
To fit any make, any model TV or radio, manufactured to exact Philco standards, thoroughly inspected. Original factory cartons.



Rotary Switch Antenna
High gain type with 6 position switch for best possible signal selectivity. 3 section brass dipoles. Padded cast iron base.



Contact Cleaner
Philco TV and Radio Contact and Control Cleaner, Lubricant in self spray can, complete with protective cap and spray nozzle.



Philco TV Yoke
Genuine Philco TV yokes, made to original factory specifications. Accurately wound and inspected. Packed in individual boxes, ready to install.

There's a Philco Fully Stocked Parts Center Near You!

IF YOU NEED A PHILCO PART...YOU CAN GET IT FAST...HERE'S WHY

1. Philco has a nationwide network of Parts distributors—THERE'S one in your area.
2. Philco distributors are backed up by Parts Warehouses with millions of dollars in Parts inventory.
3. NEW Parts for NEW Philco models are shipped automatically along with the NEW products.
4. All Parts orders are handled by experienced Parts specialists.
5. ALL EMERGENCY orders are transmitted over the nation's largest industrial communications system and processed within 24 hours.

Whatever you need—whenever you need it—if it's a Philco Part just dial your Philco distributor. He has thousands of Philco Parts right now on his shelves. If the item you need is temporarily out of stock—he can get it for you FAST. You may **DEPEND** on your Philco Parts distributor.

Customer Confidence Begins When You Use Genuine Philco Star Bright 20/20 Picture Tubes

Every OR Tube you replace represents a high-dollar service sale for you . . . and your customer. Play it safe with a brand that's known for Quality . . . PHILCO. All material and parts used in the manufacture of Philco Star Bright 20/20 Picture Tubes are new except for the envelope, which prior to reuse, has been inspected and tested to the same standards as new envelopes.

ON YOUR PHILCO DISTRIBUTOR FOR ALL YOUR PARTS AND ACCESSORIES

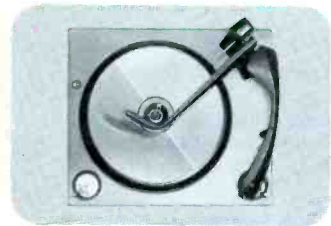

M62A 4-speed Record Changer Intermixes all size records. Light-weight tone arm with retractable scratch protection assembly and famous Euphonics U8 cartridge. Changer ideal for built-in installations or "modernizing" record playing equipment. Template and instructions included.

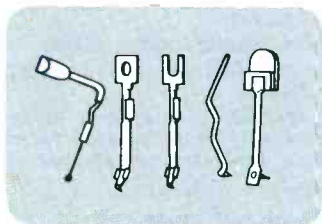

Philco Phono Needles
A complete selection of types and numbers for Philco and most all other makes. Carefully made, attractively-packaged. ALL TIP TYPES and sizes, including Diamond. Special now available—"THE BIG 18 KIT." This attractive compact metal case contains 18 of the industry's fastest selling needles.

Your Philco Distributor Features These Famous Makes

PHILCO • PHILCO-Bendix • CROSLEY • EVEREADY Batteries and Flashlights • CAROL Cables • GOODRICH V-Belts • GC Products • AUDIOTEX • WALSCO Products • COLORMAGIC Antennas • PRECISION Test Equipment

Philco Parts are Available Through a nationwide network of Parts Distributors. Mail the Coupon Today for the Name of the One Nearest You.



PARTS AND SERVICE OPERATIONS

PHILCO

A SUBSIDIARY OF *Ford Motor Company*

Circle 12 on literature card

Philco Parts & Service Operations
C & Tioga Streets, Phila. 34, Pa.

I am interested in receiving information about special Philco Parts offers, prices and facts. Please send me the name of the nearest Parts distributor.

Name _____

Address _____

City _____ Zone _____ State _____

Centralab



BRAND NEW CENTRALAB FASTATCH II® FRK-200 KIT WITH EXACT REPLACEMENT SHAFTS

Makes Control Replacement A SNAP!

- Centralab's new FRK-200 kit gives you the most convenient, most versatile, and simplest system for control replacement.
- Since it includes 13 sizes of exact replacement shafts, shaft cutting is eliminated on *all* the popular dual concentric controls and on almost 60% of all dual controls.
- The Fastatch II® Control System is a snap to use. Single and dual concentrics snap together without tools! Shafts plug in and are permanently locked. Assembled units can't loosen—shafts can't pull out.

JUST CHECK THESE EXCLUSIVE FEATURES:

1. Just one control system for dual concentric or single controls.
2. Universal terminals.
3. Plug-in, permanently locking shafts.
4. Rotary or push-pull (snap-on) line switches attach to both front and rear controls.

The FRK-200 kit is contained in two stacking Equipto steel cabinets with plenty of extra space for expansion. *All* your control needs, including push-pull, are at your finger tips.

THE FRK-200 KIT CONTAINS:

- | | |
|---------------------------------------|--|
| 35 Exact Front Shafts (7 sizes) | 9 Assorted Rear Controls |
| 30 Exact Rear Shafts (6 sizes) | 40 Assorted Universal Shafts for Single and Dual Concentrics |
| 5 Universal Push-Pull Shafts (1 size) | 5 SPST on/off Switches |
| 5 Push-Pull Line Switches | 2 DPST on/off Switches |
| 5 Twist-Tab Adapter Plates | 1 DP on/off Switch |
| 2 3-Drawer Equipto Cabinets | Complete with current cross-reference guides. |
| 27 Assorted Front Controls | |

Dealer Net \$72.50

Less Credit for your old controls!

Centralab®

THE ELECTRONICS DIVISION OF GLOBE-UNION INC.

942 A East Keefe Avenue • Milwaukee 1, Wisconsin

TWX: 414-731-8731

In Canada: Centralab Canada Ltd., P. O. Box 400, Ajax, Ontario

Automatic Brightness-Contrast Control

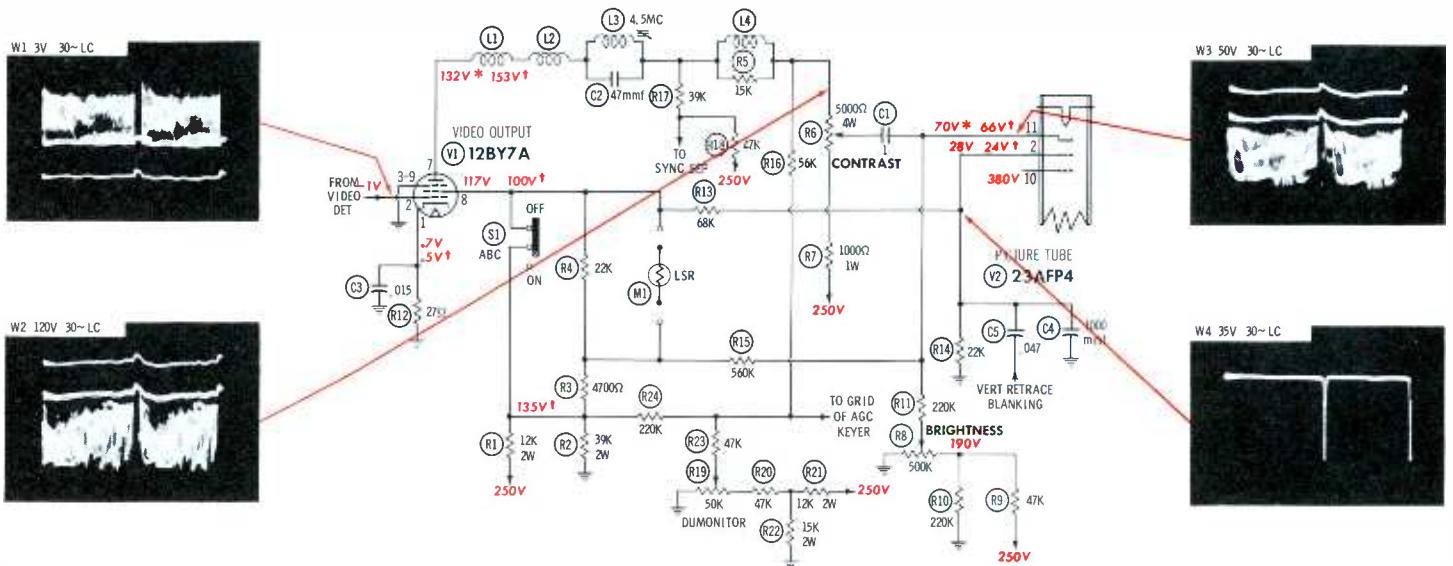

DC VOLTAGES taken with VTVM, on inactive channel;
† indicates ABC on, in moderately bright room light;
* indicates wide fluctuations (see text below, at right).

WAVEFORMS taken with wideband scope, using low-cap probe (LC); AGC control set for W1 amplitude of 3 volts; R6 set for W3 amplitude of 50 volts.

Normal Operation

Circuit is basically conventional one-stage video amplifier with manual contrast control in plate circuit. Video signal is AC-coupled to CRT cathode via C1. Heart of the ABC circuit in this set (DuMont Chassis 120692) is cadmium sulfide photoresistive cell M1, also referred to as light-sensitive resistor (LSR). Mounted at front of cabinet, it responds to changes in room lighting by varying resistance from less than 100 ohms (in very bright light) to 500 meg (in pitch blackness). Moderate illumination used as standard for this Symfact placed resistance at 2200 ohms. M1 is part of voltage divider across B+ source, including R1-R2, R3, R4-M1, R13, and R14. When room light is dimmed, M1 reacts by placing more resistance between screen grid and B+, lowering screen voltage; this results in less amplification of video signal, thus reducing contrast. Since voltage at junction R13-R14 is also lowered by action of M1, grid voltage of CRT is decreased. Bias between grid and cathode is thereby made greater, decreasing brightness. Connection to cathode via R15 slightly modifies cathode voltage to help adjust brightness-contrast ratio for more linear ABC operation; this connection also prevents operating CRT with zero or positive bias. Front-panel ABC ON-OFF slide switch can be used to disable ABC by shorting across M1-R4-R3; this normally causes slight increase in contrast. For further information on other similar circuits, see "Automatic Brightness and Contrast Control" in April, 1962 PF REPORTER.

Operating Variations

- V1 PIN 8** When ABC is switched on, DC voltage decreases by at least 15 volts; in very dark room, it may plunge down to reading of 75 volts or less. Applying station signal causes 5 to 10 volt increase, whether ABC is on or off. Although screen has no bypass capacitor, only waveform here is sawtooth-shaped .2 volt ripple.
- V1 PIN 7** Higher plate voltage with ABC on is due to reduced screen voltage. In either position of ABC switch, voltage rises 20 to 30 volts above "no signal" value when station signal is applied to receiver.
- V1 PIN 2** DC voltage is fraction of volt more negative on active channel than on vacant channel. Since plate voltage of V1 rises when ABC is on, grid voltage of AGC keyer is increased (via connection through R16); more AGC bias is then fed to IF strip, and amplitude of W1 decreases. Comparison of W1 and W2 peak-to-peak values is index of V1 stage gain—useful fact for analyzing weak-picture complaints. Gain ranges from 30 to 40; is highest with weak W1 input and ABC off.
- V2 PIN 11** R8 varies voltage over wide range—from 175 to 70 volts as control is advanced. R6 adjusts amplitude of W3 from 20 volts to full output of V1 (120 volts).

No Automatic Control

SYMPTOM 1

ABC Switch Works Normally

M1 Open



When ABC is switched on, brightness and contrast decrease markedly; picture is too dull-toned to please viewers in moderately well illuminated room. No change is noted in picture when light striking M1 is varied. Manual operation is entirely normal.

Waveform Analysis

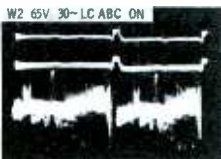
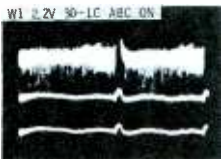

All waveforms are normal as long as ABC is off; when it is put into operation, amplitudes of W1 and W2 decrease to 2.2 volts and 65 volts, respectively. These values are normal for operation in very dark room, but expected increases do not occur when M1 is illuminated more brightly. Waveforms confirm visual impression of great decrease in contrast with ABC on.

Voltage and Component Analysis

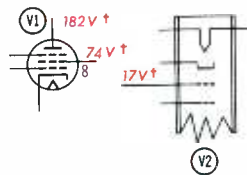

Quick check of voltages, with ABC off, reassures serviceman that video stage is okay; this isolates trouble to components that are shorted out when S1 is closed. With switch open, screen voltage of V1 and grid voltage of V2 are at low end of normal ABC range. Only condition that can completely remove automatic control is open connection to M1 itself. This unit, which is cabinet-mounted and has plug-in leads, need not be taken with chassis for shop work not involving ABC trouble; service can be performed with S1 closed. On reinstallation of chassis, ABC action should be checked to make sure M1 is working.

Best Bet: Visual analysis of symptom is sufficient.

Picture Defocused at High Brightness

SYMPTOM 2

ABC Has Some Effect

R14 Open



Satisfactory picture is obtainable at moderate settings of manual brightness and contrast controls, but tendency to excessive brightness and blooming may worry some set owners who are overly conscious of brightness faults because set has ABC feature.

Waveform Analysis

W3 has nearly normal amplitude, but is slightly distorted. Negative peaks (corresponding to whitest parts of picture) become compressed when R8 is turned up high, because these peaks drive CRT to zero bias between cathode and grid. At the same time, grid draws current and develops video signal voltage across grid-to-ground resistance—producing ripples on baseline of W4.

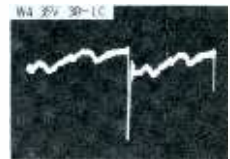
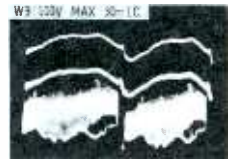

Voltage and Component Analysis

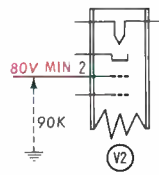

Grid and cathode of V2 are both too positive, and bias between these elements is less than normal. On station, it averages 25 volts—too little to avoid momentarily reaching zero or positive bias on some signal peaks. Internal leakage in CRT is ruled out because voltage readings are not significantly changed by unplugging tube base. Grid voltage cannot be reduced below 80 volts. Resistance from grid to ground is 90K with ABC off; this means normal ground path through R14 is open. CRT beam current is above normal, and develops unusually high cathode-bias voltage across R8-R11 that opposes effect of high grid voltage.

Best Bet: Voltage analysis—then resistance check.

Washed-Out Picture

SYMPTOM 3

Normal Brightness

L4 Open

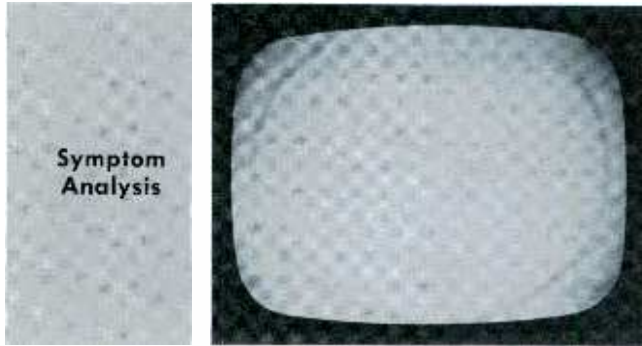

Lightest areas in picture go "flat" at high brightness levels, just as if picture tube were old and weak; but maximum brightness is too high to confirm bad CRT. Both brightness and contrast are varied by ABC. Resetting DUMONITOR helps contrast to some extent.

Waveform Analysis



With ABC off, W2 has amplitude of only 50 volts. That of W1 is 5 volts—unusually high because AGC is trying to compensate for poor output of V1 stage. Both waveforms are slightly weaker when ABC is on. Negative peaks of W2 and W3 are compressed, for different reason than in Symptom 2; signal tracing in plate circuit reveals huge (240 volt) waveform ahead of L4-R5.

Voltage and Component Analysis

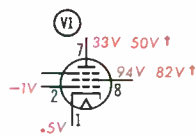

Plate voltage of V1 is definitely too low under all conditions. Cathode voltage indicates lower-than-normal cathode current; thus, error in plate voltage cannot be pinned on excessive current through plate circuit. Large voltage drop between plate and B+ is due to increased resistance between these points. Quickest test procedure is to trace through plate circuit with voltmeter, looking for suspiciously large voltage drop across some individual component or network. Difference of over 100 volts is noted in readings on opposite sides of L4-R5. R5 is running extremely hot, but is not burned. Dissipation figures out to 2 watts.

Best Bet: Voltage analysis by circuit tracing.

Low Brightness

ABC Functioning

C1 Leaky

SYMPTOM 4

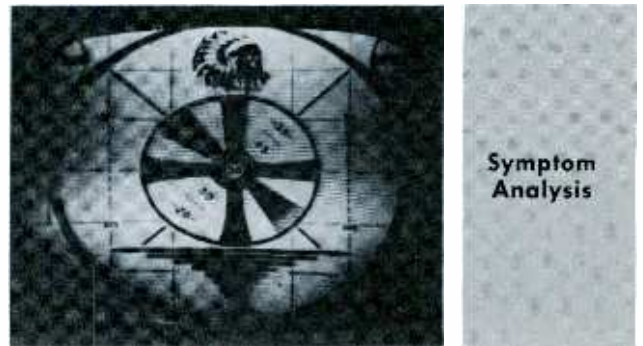

Brightness and contrast controls must be set at maximum to make picture clearly visible. Contrast is then good, but brightness is too low for daytime viewing. Raster is even dimmer when ABC is on. No defocusing or blooming indicates good HV.

Waveform Analysis

Video signal is normal at all points in circuit, including CRT cathode. W3 varies smoothly in amplitude as R6 is turned. W4 is also correct; thus, trouble is not interfering with signal paths in CRT gun circuits. Aside from this point, waveforms are not particularly helpful in finding this defect. Poor brightness with normal contrast usually means DC problem on CRT gun.

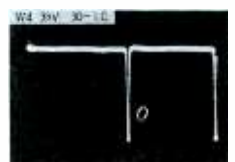
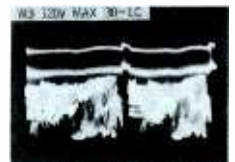

Voltage and Component Analysis

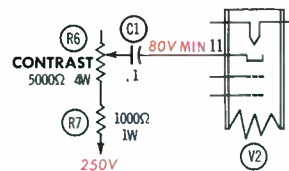

Normal voltages are found at control grid and accelerating grid of V2. However, cathode voltage is too positive—cannot be reduced below 80 volts (on inactive channel) or 90 volts (on station) by adjusting R8. This control is found to be working normally; voltage on arm is zero at maximum brightness setting. Another suspect, C1, can be given simple in-circuit check by adjusting R6 while monitoring DC cathode voltage of CRT. If C1 is leaky or shorted, change in cathode voltage will be much greater than the 5 to 10 volt shift normally introduced by large variations in signal amplitude. In this case, variation is 30 volts.

Best Bet: Check DC voltages—then components.

SYMPTOM 5

Dull Picture With ABC On

Normal Control of Brightness

R1 Increased in Value

Symptom Analysis



ABC exerts automatic control, but not sufficiently to maintain desired picture quality under all lighting conditions. In brightly lit room, effect of strong contrast cannot even be obtained by manually adjusting R6. Turning ABC off improves picture slightly.

Waveform Analysis

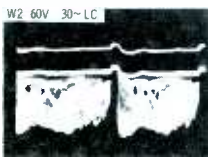

Even with ABC off, W2 is weak—only 60 volts at setting of DUMONITOR that gives greatest possible contrast. W1 measures 2.4 volts—also a bit below normal. Switching ABC on causes W2 to drop to 55 volts; this small decrease has surprisingly great visible effect on picture. Another possible clue to trouble is slight compression of sync pulses present in W2.

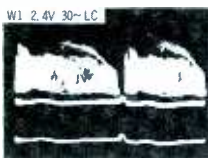

Voltage and Component Analysis

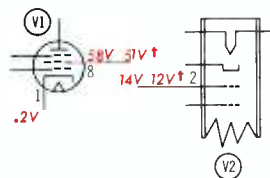

Screen voltage of V1, off channel, is about half of normal—whether ABC is off or on. Grid voltage of V2 decreases in same proportion; this is clue that R13-R14 and other grid-circuit components are okay, and trouble is between V1 screen and B+ source. Low cathode voltage on V1 is indirect evidence of low screen current. B+ source voltage is correct; thus, fault in voltage divider R1-R2 seems likely. Resistance check, out of circuit, indicates R1 has risen in value to 60K. In-circuit resistance checks of this network are difficult because of parallel paths to ground in ABC circuit itself, as well as in B+ load circuit.

Best Bet: Voltage tests; then resistance tests.

Blank Raster

SYMPTOM 6

Suspicion of AGC Trouble

R7 Open

Symptom Analysis



When station is tuned in, picture is whited out, but smeary video (out of sync) is seen on some adjacent channels. It also appears on active channels if AGC is adjusted with DUMONITOR. This is no ordinary AGC fault; no picture appears on weak stations.

Waveform Analysis

Clamping AGC line does not remedy trouble, so clamp bias is removed. When DUMONITOR is set for scrambled video on CRT, W1 is nearly normal in shape, but has 15 volt amplitude—enough to overload V1 and crush sync pulses in W2. In whiteout condition, W1 is weak and distorted, but it would produce some sort of pattern on CRT if V1 were amplifying it normally.

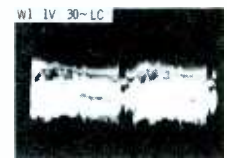
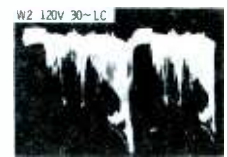

Voltage and Component Analysis

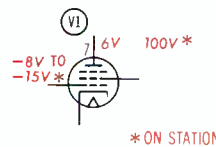

On stations, V1 grid is overbiased (-8 volts with video visible, -15 volts in whiteout); this is typical sign of too much IF gain. Since some symptoms run counter to usual behavior of AGC faults, search is made for IF or video trouble. Routine voltage tests, off channel, disclose only 6 volts at all points in plate circuit of V1. On station, when plate current goes down as consequence of high grid bias, plate voltage rises above 100 volts. This high voltage is obtained via secondary B+ feed paths through high resistance of R17-R18 and R23-R20-R21. Red herring "AGC symptoms" might turn this simple trouble into a dog.

Best Bet: Voltage analysis, aided by scope.

STOP!

LOOK!

SAVE!



A
STANDARD
COLOR BAR
GENERATOR
at **1/2**
THE COST OF
OTHERS

only **\$124⁵⁰**

All crystal controlled

the all new **SENCORE** CG126 STANDARD COLOR BAR GENERATOR

A standard color bar, white dot, crosshatch generator especially made for field service on color TV . . . and at a great savings to you.

Check these outstanding features and you will see why this generator belongs on the top of your list for color TV servicing.

All patterns crystal controlled offering "rock like" stability. You'll think the patterns are painted on the TV screen.

Simplified operation speeds up every servicing job. Just dial the standard keyed bars, white dots, crosshatch, vertical bars or horizontal bars and watch them "pop" on the screen. That's all there is to it.

Exclusive adjustable dot size. The white dots can be adjusted to the size that satisfies your needs by a screwdriver adjustment on the rear. No need to argue about dot size anymore. Just select the size that you like to work with best.

Pretuned RF output to Channel 4. Other low channels can be selected if Channel 4 is being used in your area by simple slug adjustment. Patterns are injected directly into antenna terminals, simplifying operation and saving servicing time.

Reserved output on color bars for forcing signal through defective color circuits. The color output control is calibrated at 100 percent at the center of rotation, representing normal output. A reserve up to 200 percent is available on the remainder of rotation.

Smaller and more portable. With color receivers weighing much more than black and white TV, portable equipment becomes essential for home servicing. The CG126 weighs less than 10 pounds and measures only 11" x 8" x 6".



Ten standard keyed color bars (RCA type) that automatically provide all colors at specified NTSC phases . . . but without need of interpretation when servicing.

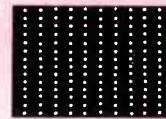

Stable white dots with new exclusive dot size adjustment in rear.



Stabilized crosshatch pattern for simplifying convergence adjustments.



10 thin white vertical lines for horizontal dynamic convergence adjustments . . . often missing on other generators.

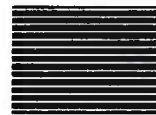

14 thin horizontal lines for vertical dynamic convergence. Also missing on many high priced generators.

March into your local parts distributor and demand the CG126 Sencore color generator that sells at 1/2 the price of others. Don't let him switch you.

SENCORE

426 SO. WESTGATE DRIVE • ADDISON, ILL.

Within the past several months, numerous models of transistorized ignition systems have made their appearance. Many are designed to be added to existing systems; others are original equipment on some automobiles.

In the latter case, care has been taken to keep servicing within the ranks of auto mechanics. But that has caused some difficulty. Auto mechanics as a rule know little about electronics or transistors, and service technicians care little about the workings of auto ignition systems. The results for the car owner have been less than desirable.

Nevertheless, these systems have found their way under the hood of a large number of automobiles, and are operating after a fashion. Several have been installed by do-it-yourself mechanics, and with some success, thanks to instruction sheets furnished with the kits. But thousands of kits are being sold, installed, and serviced by electronics service-men.

Units that have gone bad for one reason or another have frequently wound up in the shop of the local electronics expert. This is because the troubles that have occurred have been primarily electronic. Let's examine a few typical systems, and then see how a competent service technician troubleshoots these units. Put on your coveralls, for we'll be looking under the hood of a few cars.

How Ignition Works

Most technicians understand the conventional ignition system of an automobile, and know how to troubleshoot it. But for those who don't, here's how it functions. Fig. 1 shows the 12 volt, negative-ground, 6-cylinder system used in modern American cars. We'll use this example in all our explanations.

When the ignition switch is closed by turning the key, battery voltage is applied to the primary of the coil, which is returned to ground through the breaker points. Current flows and sets up flux lines around the windings. As the engine is cranked, a breaker cam on the distributor shaft forces the points open at 60° intervals (45° intervals for 8-cylinder engines).

Each time the points open, the magnetic field collapses around the primary winding. The collapsing

Service Procedures for

by Larry Allen

flux lines cut the many turns in the secondary winding and generate a high voltage pulse—usually 15 or 20 kv. This pulse is fed via a well insulated wire to the center of the distributor cap, into the distributor, and to the rotor. The rotor, which is also driven by the distributor shaft and moves in synchronism with the breaker, transfers the pulse to the proper spark-plug wire. From there the pulse (often called "the spark" by auto mechanics) goes to the spark plug, jumps the plug gap inside the cylinder, and fires the mixture of gasoline and air in the cylinder.

Because of the counter-emf generated by the coil primary, a considerable voltage builds up across the points as they open. To suppress undesirable sparking, a capacitor (still called *condenser* by auto repairmen) is connected in parallel with the points; the capacitor absorbs energy developed by counter-emf and keeps the points from wearing out too rapidly.

Transistorizing the System

For a number of reasons, of interest mostly to automotive engi-

neers and racing fans, conventional ignition systems develop greater inefficiencies as the engine speed increases. Of the ways that have been developed to combat this, the transistorized ignition system seems to offer the most advantages. High-speed, high-power switching transistors have made these systems practical and economical.

The transistorized ignition system (Fig. 2) consists mainly of a switching transistor substituted for the breaker points in the primary of the ignition coil. Additional improvements are obtained by using a special coil in conjunction with the switching transistor, to develop voltages from 30 to 60 kv. The breaker points are retained in most systems, but gone is the heavy load on them (caused by coil current and counter-emf) and the need for a "condenser."

Transistorized systems fall into three general categories: original equipment, installed on the car at the factory; add-on units using the original ignition coil; and add-on systems which include a specially designed coil. Installation instructions are always furnished with the latter two, and with the kits of components that are available, so there is little to be gained by rehashing installations. We'll therefore assume the systems we are about to discuss have been installed and were working at one time; your job is to find out what has gone wrong to stop the system from working.

Troubleshooting Ignition

As with troubleshooting any electronic device, the first step is to verify the complaint. Some auto mechanics may find it easier to

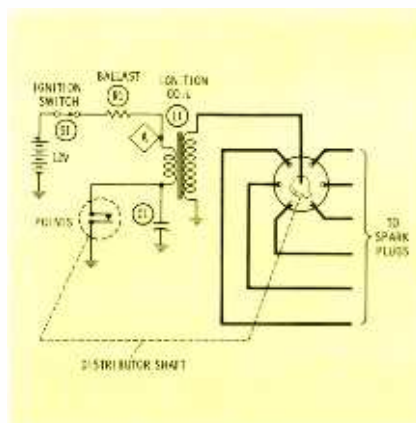
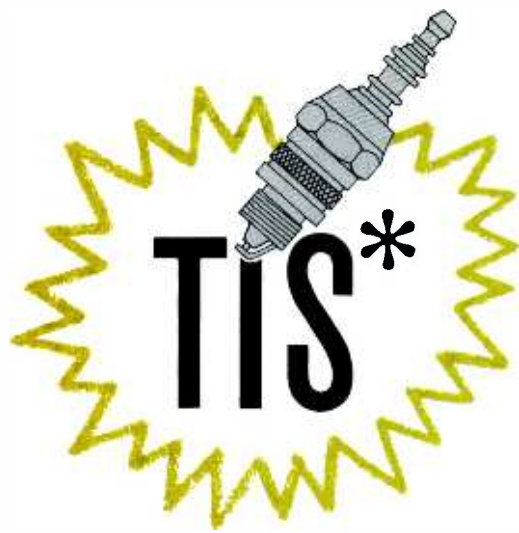

Fig. 1. A conventional auto ignition system.



* TRANSISTORIZED IGNITION SYSTEMS

blame the transistor section than to trace other trouble. Thus, your first order of business should be to ascertain just where the trouble actually lies. The technique given here is not the only one; but it is logical, and we recommend it.

An ignition system performs a definite sequence of events, as described in the first part of this article. We can troubleshoot most logically by checking each action in order.

Most of the tests can be made without even removing the distributor cap. Use a VOM with its negative lead connected to ground. The ignition switch terminals are often difficult to reach, so turn the key on and check for voltage at the original ignition coil (L1 in Fig. 1); if the switch is okay, the voltage at point A will be between 9 and 12 volts, depending on the system.

Fig. 3 shows a system that is wired somewhat differently. In many late-model cars, the ignition ballast resistor R1 is a wire inside the wiring harness instead of a separate resistor in the engine compartment. Since the switcher must receive full voltage from the battery, with no drop except that provided by its own ballast resistor (R2 in Fig. 2), relay M1 may have been installed with the system you're servicing. The B terminal is connected to some convenient source of full battery voltage (point B)—the hot side of the starter solenoid, the "Batt" terminal of the voltage regulator, or even the hot side of the horn relay. The A terminal of M1 goes to the switcher. When the ignition switch is turned on, the relay closes and applies full

voltage directly to the unit (or to its special ballast resistor).

In troubleshooting the system in Fig. 3, it is probably best to start by checking for voltage at terminal A of relay M1—usually the most convenient measuring point. If it is missing, check for voltage at point A, which is the hot side of the relay coil and is connected to the input terminal of the old ignition coil. Lack of voltage at point A indicates an open ballast resistor or faulty ignition switch. If normal voltage (7 to 10 volts) is available at point A, yet there is no voltage at terminal A of the relay, the relay coil is bad and the relay isn't pulling in, or the connection from terminal B to the power source (point B) is faulty. (If you wish to test the remainder of the system before repairing any trouble already located, you can connect a temporary jumper directly from point B to relay terminal A, thus bypassing the ignition switch.)

The remaining steps apply to both Fig. 2 and Fig. 3; their object is to determine whether the coil or the switcher is faulty. Connect your VOM to terminal 2 of the switcher, and set its range for 10 volts. Crank the engine. Each time the points open, the VOM needle should deflect slightly, indicating that the breaker is working. If there is a continuous reading, the points are remaining open; if there is none whatsoever, the points are sticking.

If the tests we've outlined clear the breaker points of suspicion, connect the VOM to terminal 3 of the switcher. When the engine is cranked, there should be regular deflections of the meter. If not, the transistor unit is probably faulty.

If the switcher is okay, move the voltmeter directly to the input (ungrounded) terminal of coil L2—point C. Cranking the engine should cause meter deflections the same as at terminal 3 of the switcher unit. If not, the wire itself is faulty, the input terminal is shorted to ground, or—in Fig. 3 only—network R2-C2 is faulty (R2 open or C2 shorted).

Next, be sure the input coil is grounded properly, as the primary ground terminal is sometimes external. To check the coil, remove one end of the high voltage wire from the center of the distributor cap, and place its bare end about ¼" away

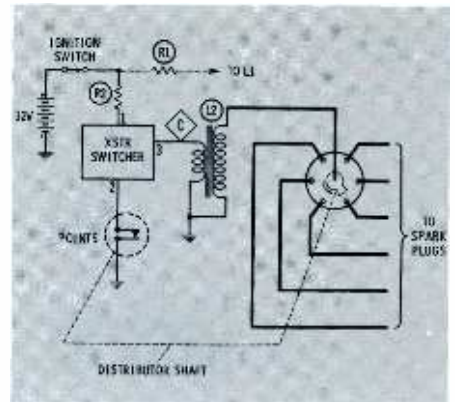

Fig. 2. Transistors take load from points from the engine block (don't let it touch). Cranking the engine should produce a series of clean blue sparks, one for each time the points open. You can simulate this action by disconnecting the points lead from terminal 2 of the switcher, and using a jumper to make and break contact with ground; each break should produce a spark from the tip of the high voltage lead.

If all is normal up to this point, the trouble must be with the rotor, the distributor cap, or the spark plug wiring. Reinsert the high voltage lead into the center of the distributor cap, remove a spark plug wire, hold the tip near the block, and crank the engine. A healthy spark should jump from the tip each time the rotor moves past that particular plug-wire terminal inside the distributor cap. Each plug wire can be checked in this manner.

This entire series of tests takes only a few minutes. To summarize this troubleshooting procedure: Make sure power is applied to the switcher. Make sure the breaker points close and open properly. Be sure the switcher produces a pulse each time the points open. Be sure that pulse is reaching the coil.

• Please turn to page 68

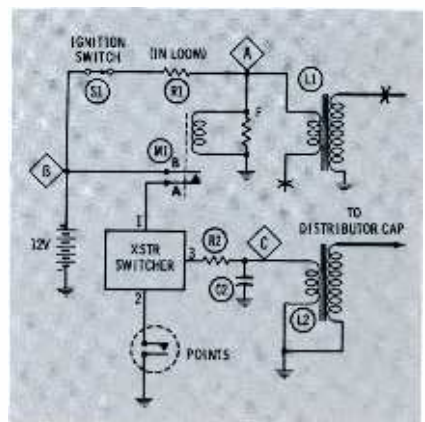

Fig. 3. A relay bypasses ballast resistor.

an
inside
look
at

similar to the circuit shown in Fig. 1, with two major exceptions:

In the first place, the early pulse-width circuit had three inputs to the grid of the AFC stage; in addition to the conventional sync pulse and sample of the oscillator's sawtooth output, there was another sawtooth that was obtained by integrating a strong negative pulse fed back from the flyback-yoke circuit. The triple connections to the AFC grid are shown in Fig 2. Incidentally, it is interesting to note that

relationship with the external signal.

In the *Synchroguide* application of this principle, a sample of the oscillator signal and a positive sync-pulse signal are both applied to the grid of control tube V1A. Neither the sample signal nor the sync signal alone is capable of causing conduction of the control tube. However, when the timing of the oscillator is such that the sync pulses ride atop the positive peaks of the oscillator sample signal, the sync-pulse tips reach a high enough level to make

SYNCHROGUIDE

One of the most common types of horizontal AFC-oscillator circuits in TV receivers has come to be known by servicemen as *Synchroguide*. The circuit consists of two triodes, one operating as a blocking oscillator, and the other as an automatic frequency and phasing control.

Although several versions of this circuit have been developed, the form shown in Fig. 1 has been the most popular. Its use has spanned a number of years; it is found in receivers produced as early as 1950 and as late as 1962. This circuit evolved from the original *pulse-width* horizontal system, which was

early circuit descriptions credited this third signal with improving synchronization, but it actually made the system more critical in some receivers. In certain cases, it introduced a peculiar horizontal jitter.

Secondly, the older circuit did not include the ringing-coil network (B2 in Fig. 1). The only true *Synchroguide* circuits, in the usual understanding of the term, are those making use of this adjustable tank circuit for stabilization.

Circuit Operation

All automatic control systems operate on the same principle—a sample signal from the circuit to be controlled is combined with an external signal to develop a controlling force. This force is then used to adjust the operation of the circuit so its output will have the desired

V1A conduct. The resulting pulses of plate current in the tube develop a positive voltage at its cathode. A portion of this voltage appears across R3 (Fig. 1) in opposition to the grid-leak bias voltage produced by the oscillator; this reduces the oscillator bias by the proper amount to correct any phase or frequency deviation of the sample signal with respect to the sync signal.

The main factor in determining the amount of control voltage is the length of time the grid of V1A is held above cutoff by each sync pulse. Reference to actual grid waveform will show how the effective duration of the pulse is varied.

Figs. 3A and 3B, depicting the sync and sample signals W1 and W2, were taken by disconnecting capacitors C1 and C2 from the grid and touching the scope probe to the loose end of each capacitor in turn. With the capacitors reconnected, the combined waveform W3 was obtained at the grid. Its waveshape looks like Fig. 3C when the oscillator is operating at the lowest possible frequency within the hold-in range. In this case, the leading edge of the sync pulse rides high on the positive peak of the sample signal. The trailing edge slides down to a lower level because its footing is on the steep, negative-going retrace slope of the sample signal; nevertheless, the pulse remains above the conduction threshold long enough to make V1A develop a relatively high positive correction voltage. At the high-frequency end of the hold-in range,

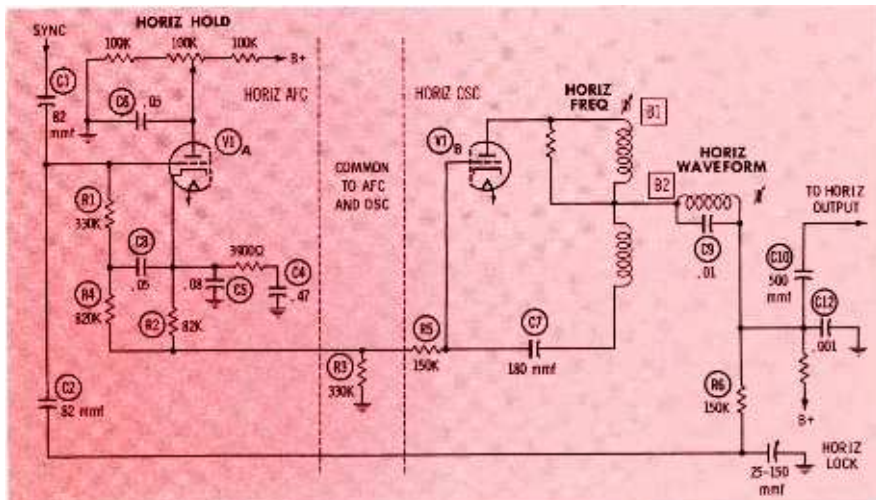

Fig. 1. Several forms of *Synchroguide* circuit have been devised; this is most common.

the sample signal begins its negative slope before the pulse arrives, and only the leading edge of the pulse rises high enough to drive VIA into conduction. Under these conditions, much less control voltage is generated, and the oscillator is allowed to run at a speed closer to its natural frequency.

As in other types of blocking-oscillator circuits, a large degree of frequency correction is possible only when the oscillator frequency is lower than the normal sync-pulse frequency. The greatest decrease in frequency that can be overcome is approximately 200 cps. Beyond these limits W1 and W2 fail to combine into a stable W3 (note Fig. 3E); therefore, conduction of the control tube is irregular, and the control voltage developed at its cathode fluctuates in value and polarity. In general, the frequency-correction range of a *Synchroguide* circuit is narrower than that of other AFC systems.

A potentiometer that varies the plate voltage of the control tube governs its conduction and serves as a very effective hold control. Other means of adjustment are also possible; later versions of the circuit, in particular, often use a fixed AFC-plate voltage and have a hold control consisting of a variable grid-leak resistance or a tunable plate coil in the oscillator stage.

Servicing Techniques

Routine resistance and voltage checks are useful in solving the less critical types of troubles encountered in *Synchroguide* circuits. Resistance measurements are especially likely to pay off, because these circuits contain many large-value resistors that are prone to change in resistance. Normal readings are readily obtained by checking color codes or by studying the schematic.

Voltage readings are sometimes deceptive, since minor changes in operating conditions can introduce variations that exceed the normal tolerances allowed in interpreting schematic data. Particular caution needs to be exercised in trying to gauge the effect on circuit voltages when a sync signal is applied to the control stage. In some sets, for example, the cathode voltage of this stage will vary quite a bit as the hold control is adjusted; in other sets this voltage will remain almost constant

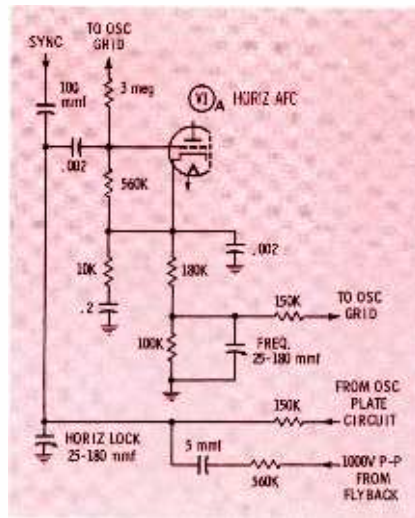

Fig. 2. Pulse-width circuit, forerunner of *Synchroguide*, had three signal inputs to AFC.

except when horizontal sync is lost. If obvious trouble is reflected by voltage readings, so much the better; otherwise, excessive reliance on voltage checking can waste considerable time.

Even the slightest leakage in a grid-circuit capacitor, too small to be detected with in-circuit measurements, can upset horizontal sync. Most other capacitors are less sensitive, and leakage severe enough to cause trouble will often show up in routine voltage checks—although some pretty close reading and careful interpretation of the voltages may be necessary.

Visual Analysis

Stubborn troubles in *Synchroguide* circuits are best approached by analyzing the symptoms and relating

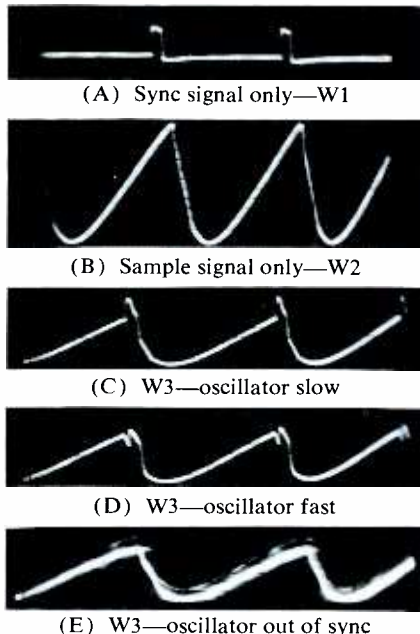

Fig. 3. Typical input signals to grid of AFC section in *Synchroguide* circuit of Fig. 1.

them to the known characteristics of a normal circuit. The CRT screen presents much information that is useful in determining the exact nature of the defect. For instance, bars sloping down to the left (Fig. 4A) are a sign that the oscillator is running slow or lagging behind the sync pulses. As the frequency adjustment or hold control is turned toward the correct setting, the number of bars should diminish until only three or four remain; then the picture should suddenly pull into sync. The pattern shown in Fig. 4B, with only two bars slanting down to the left, is an abnormal indication that warns of unusually critical *Synchroguide* operation.

Blanking bars sloping down to the right (Fig. 4C) signify an oscillator frequency slightly faster than the sync-pulse frequency of 15,750 cps. The bars will become fewer as the circuit is adjusted toward the correct frequency, and just before the picture pops into sync, a single upright blanking bar will appear in midscreen—see Fig. 4D. This pattern may remain in a fairly steady state at one critical setting of the frequency slug or hold control, thereby illustrating a peculiarity of the *Synchroguide*: it can run at the correct frequency and still be out of phase with the sync signal. Fig. 5 shows the control-tube grid waveform that corresponds to this out-of-phase condition.

If the terminals of the horizontal waveform coil are shorted together while the set is operating as shown in Fig. 4D, the oscillator will shift to a higher frequency, and multiple slanting bars will appear on the screen—see Fig. 6. This demonstration is evidence of the improved stability that results from the addition of the waveform coil to the circuit. Practical benefits of this feature include a high degree of immunity to noise bursts and extraneous signals—overcoming a weakness of the original pulse-width circuit.

The latitude of the frequency and waveform adjustments in a *Synchroguide* circuit is great enough to cover up minor faults; so, if any adjustment has to be set near one end of its range to keep the picture in sync, this is a sign that the real trouble hasn't been corrected. For

• Please turn to page 62

Although it is very desirable to include an automatic frequency control system in every FM receiver, one drawback has been cost of the extra components required. This drawback has been overcome; manufacturers are taking advantage of new developments in variable capacitance devices and a high percentage of new FM receivers now use these devices in their AFC circuits. Even lower priced FM receivers include AFC, because the cost increase is very slight.

What Is AFC?

The local oscillator in an FM receiver operates at a very high frequency, only 10.7 mc away from the station frequencies. The AFC system compensates for any possible frequency drift, making it unnecessary to retune the receiver if the oscillator does drift during warmup or operation. AFC thus offers easier tuning for the nontechnical or inexperienced FM listener. When the receiver is tuned near to the desired station signal, the AFC system takes over and forces the oscillator to "lock-in" at the correct frequency.

In the past, this control has been accomplished by complex reactance-tube arrangements, involving an additional tube and a considerable number of associated parts. Operation of these complex devices was not always easily understood, and too often they were disabled rather than repaired.

With the new, simplified AFC circuits we're going to discuss here, operating theory is not at all complicated. Centering around the characteristics of that semiconductor discovery, the variable-capacitance diode (often called a *varicap*), modern AFC systems are easy to understand and service. No longer is there any excuse for leaving an AFC system inoperative.

The Key Component

Before we get into the actual operation of the AFC circuit, let's examine the variable capacitance unit itself.

A variable capacitance unit is actually a silicon junction device, the construction of which is shown in Fig. 1A. It consists of a P-type material (mostly mobile positive charges) and an N-type material (mostly negative charges or mobile electrons). The device offers high

meet new
circuits
that perform
well-known
functions

New AFC

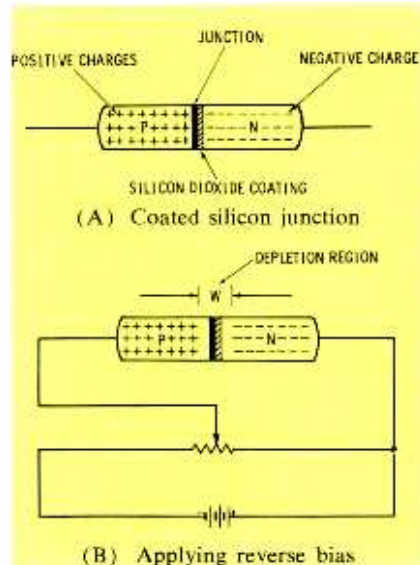

Fig. 1. Showing construction and operation of semiconductor variable-capacitance unit.

resistance to current flow in one direction and low resistance in the other—a characteristic typical of PN junctions.

A coating of highly resistive silicon dioxide is used as a masking

agent on the junction of the P- and N-type materials, to control the characteristics of the unit. The capacitance of the device depends on how much of the junction area is masked, and the thickness of the masking material.

Varying the Capacitance

In Fig. 1B, a battery is shown connected to the terminals of a variable capacitance device through a controllable resistance. The voltage is applied in the direction opposite to easy current flow (reverse bias), with the setting of the potentiometer controlling the amount of applied voltage.

The quantity of the P and N charges adjacent to the junction can be reduced virtually to zero when reverse bias is applied across the terminals. This region adjacent to the junction will be referred to as the *depletion region*. The thickness of the depletion region is designated by the letter W in Fig. 1B.

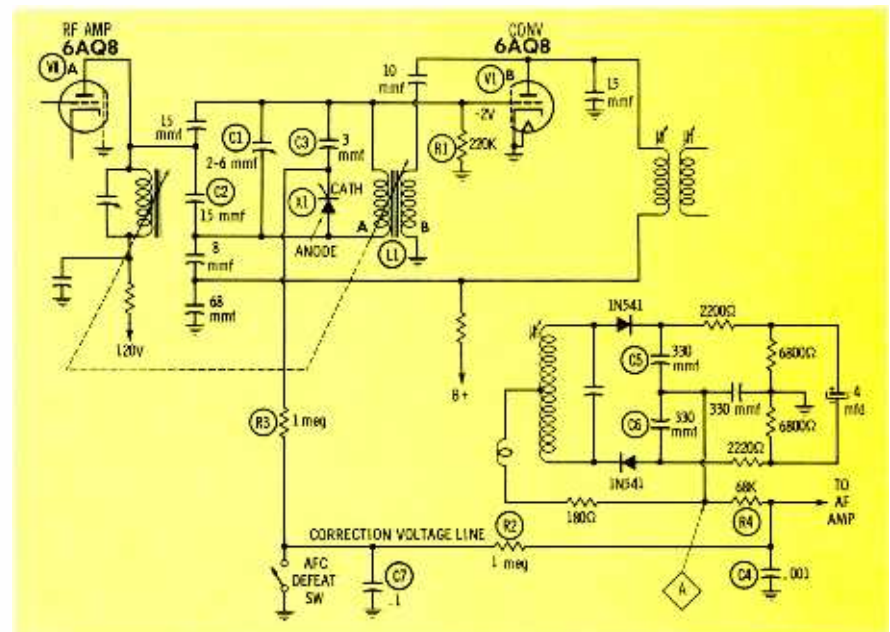

Fig. 2. Typical AFC circuit utilizing the grid voltage from the mixer for fixed bias.

Systems for FM

by Larry Ritorto and Forest H. Belt

By turning the potentiometer so that a greater reverse bias is applied across the junction, depletion region *W* will get thicker; the positive charges in the P-type material and the negative charges in the N-type material will be drawn farther away from the junction as reverse bias is increased. The effective distance between the P- and N-type materials has thus been changed by varying the applied voltage. Since the capacitance value depends on the thickness of *W*, the changing voltage controls it.

The depletion region is equivalent to the dielectric of a conventional capacitor; the P- and N-type materials are the plates, and the symbol *W* represents the distance between the plates. The P-type material of the variable capacitance device is usually referred to as the anode, and the N-type material as the cathode.

The actual size of the variable capacitance device is rather small; it is seldom more than a quarter-inch

in length and about a sixteenth-inch in diameter. The relative size of the device and the thickness of the depletion region have been greatly exaggerated in Figs. 1A and 1B, to show how the capacitance of the unit is varied.

How It Works

To see how this variable-capacitance unit can be used in a modern AFC system, let's review just how the AFC system works. The prime functions of the full AFC system include detecting any shift in local oscillator frequency, developing a correction voltage, and applying the latter in some manner to correct the frequency drift.

The detection device is a part of any FM demodulator; if the oscillator shifts frequency even slightly, the IF frequency is affected, and the ratio detector or discriminator develops a corresponding unbalance. Thus a positive or negative DC correction voltage is developed at

the demodulator of any normally operating FM set.

The polarity of this DC output voltage is determined by the direction in which the diodes are connected in the circuit. If the detector produces a negative voltage when the oscillator drifts high, a positive voltage will be produced when the oscillator drifts low; and vice versa. These DC voltages are proportional to the amount of oscillator drift (i.e., the farther they drift, the greater the voltage produced).

The audio portion of the demodulator output is filtered out, leaving only DC voltage for AFC. This is the correction voltage that will vary the capacitance of the device that controls the local oscillator frequency.

Typical Circuit

A typical AFC circuit employing the variable capacitance device is shown in Fig. 2. Capacitor *C1* and coil *L1A* form the main tank circuit. *X1* is the variable-capacitance diode, connected in series with a 3 mmf capacitor (*C3*); the combination is connected across the oscillator tank circuit.

The converter grid voltage, which measures -2 volts, is used as a fixed voltage source, to establish reverse bias in normal operation. This negative voltage is applied to the anode of *X1* through oscillator coil winding *L1A*, and is reverse bias. The cathode is connected through *R3* to the correction voltage source; when the oscillator is on frequency, this voltage is zero.

Point A is the takeoff point at the FM detector for the audio and the DC component. The audio signal is fed through deemphasis network *R4-C4* to the audio amplifier grid.

On the AFC correction voltage line, the audio portion of the output is filtered out because of the long time constant of *R2* and *C7*. This leaves only a DC component which is proportionate to any slight frequency shift of the oscillator. This DC "correction" voltage is applied to the cathode of *X1* through *R3*, and thus controls the local oscillator frequency.

Correcting Drift

A balance exists at the detector output when the receiver is tuned

Please turn to page 72

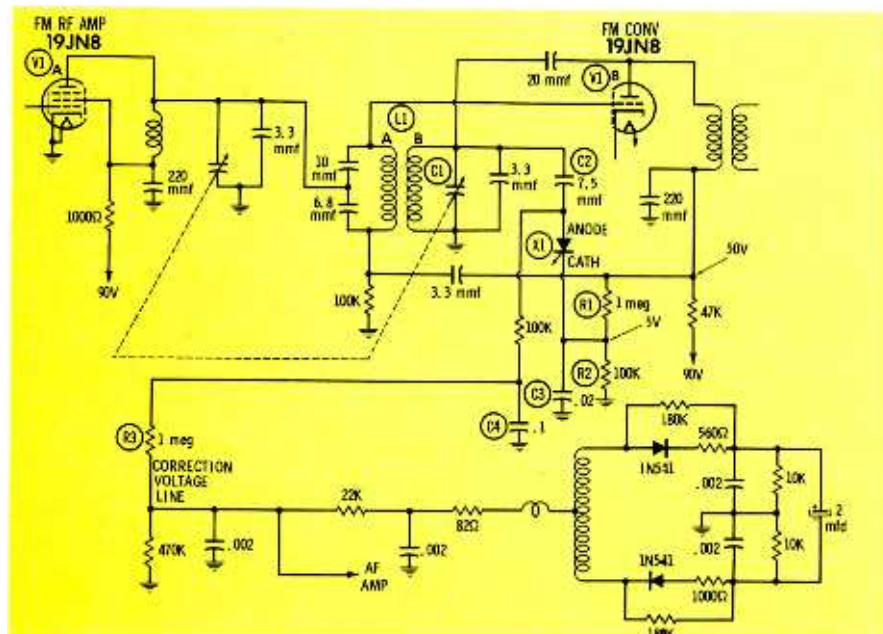

Fig. 3. Primary difference in this AFC circuit is unusual method of obtaining fixed bias.

Color Chassis or CRT

DON'T LET SYMPTOMS
THAT ARE SIMILAR
MISLEAD YOU

by Carl Babcoke



Have you ever diagnosed a certain defect in a black-and-white receiver as being caused by the picture tube, only to find the problem glaringly evident on the screen of a newly installed tube? If so, just multiply the dollar cost of this mistake by three, your lost time by ten, and you will have an idea of the situation if you had made such a “boo-boo” in a color set.

I still shudder a little when I remember some of the times we have come perilously close to this kind of disaster in our own color servicing. Listen in on these case histories and take note of their solutions.

Dull Highlights

There was the time that George, one of our servicemen, called in about an RCA set using a CTC12 chassis. He said the receiver had a severe case of *white compression* when the brightness control was advanced, and he assumed that all three CRT guns had low emission. During our conversation, he also mentioned that the customer had reported the trouble had started suddenly. At this, a little alarm bell rang softly in the back of my head. This information didn't rhyme with the way picture tubes usually go weak—it's usually a slow and gradual process. Looking for further clues, I asked George if the compression decreased as the set warmed up.

“No change,” he said.

“How is tracking of the bright and dark parts of the picture?” I pursued.

“Seems to be okay.” Then in a rush of words, “the brightness is pretty good, too, so maybe it isn't a bad picture tube after all. I'll check the video amplifiers.”

The next morning, George reported he had found one side of the

two-winding peaking coil in the video stage (T1 in Fig. 1) to be open, and had been able to resolder the bad lead. We decided to examine the diagram together, to determine how this coil caused the compression.

With the coil open, plate current through the 12BY7 video output had to flow via R1; this additional resistance lowered the plate voltage enough to cause clipping of the picture highlights. However, the brightness level of the picture was not affected very much, because the CRT bias control and R2 still supplied *some* fixed voltage to the cathodes of the CRT.

Tester May Not Tell

To avoid second-guessing the condition of a color CRT in the future, we bought a color adapter socket for our old picture tube tester. We then breathed a sigh of relief, but it was of short duration; the very first time we tried out the adapted tester, it showed all three guns to be weak and erratic!

We might have foolishly accepted this as the true condition of the tube,

had George not been alert to one important fact: The complaint was *no raster*—not dim picture. So, we didn't stop there; we substituted for the tubes in the horizontal circuits until we got a raster. To our amazed eyes, the picture had full brightness and contrast, with *no* sign whatever of low CRT emission!

Since this particular set was on the sales floor, and another color set was handy, we decided to give the tester another chance. The result was the same: the tester indicated the tube was weak, although the receiver produced a perfect picture.

A quick phone call to the supplier of the adapter produced the interesting news that this situation was not unusual with many very old picture tube testers. They were designed to deliver 600 ma of heater current and simply could not supply the 1800 ma needed for a color tube, without dropping the filament voltage. They advised us to send the tester back to the manufacturer for modification, so we did.

Missing Red

Here's a real brow lifter! Eddie (another of our technicians) brought in a complete RCA model that used a CTC11 chassis. He insisted that the picture tube *had* to be bad. His remark was, “There is *no red* whatever in the raster for about 2" on the left side of the screen.” He explained that he had moved both the yoke and the purity magnet in an effort to shift this no-red area, but it remained in the same place. Maybe the red dots were missing in this area; perhaps they had fallen off, just as the screen coating does occasionally on a monochrome tube.

This unusual line of thought aroused the interest of the other

• Please turn to page 75

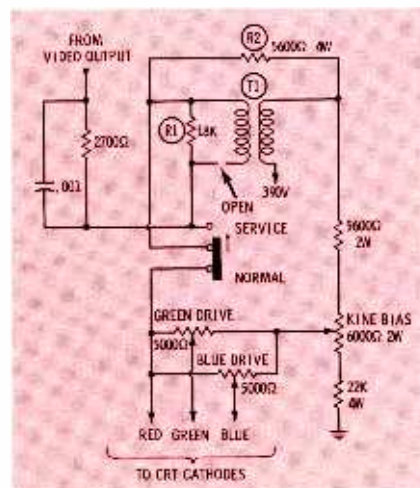
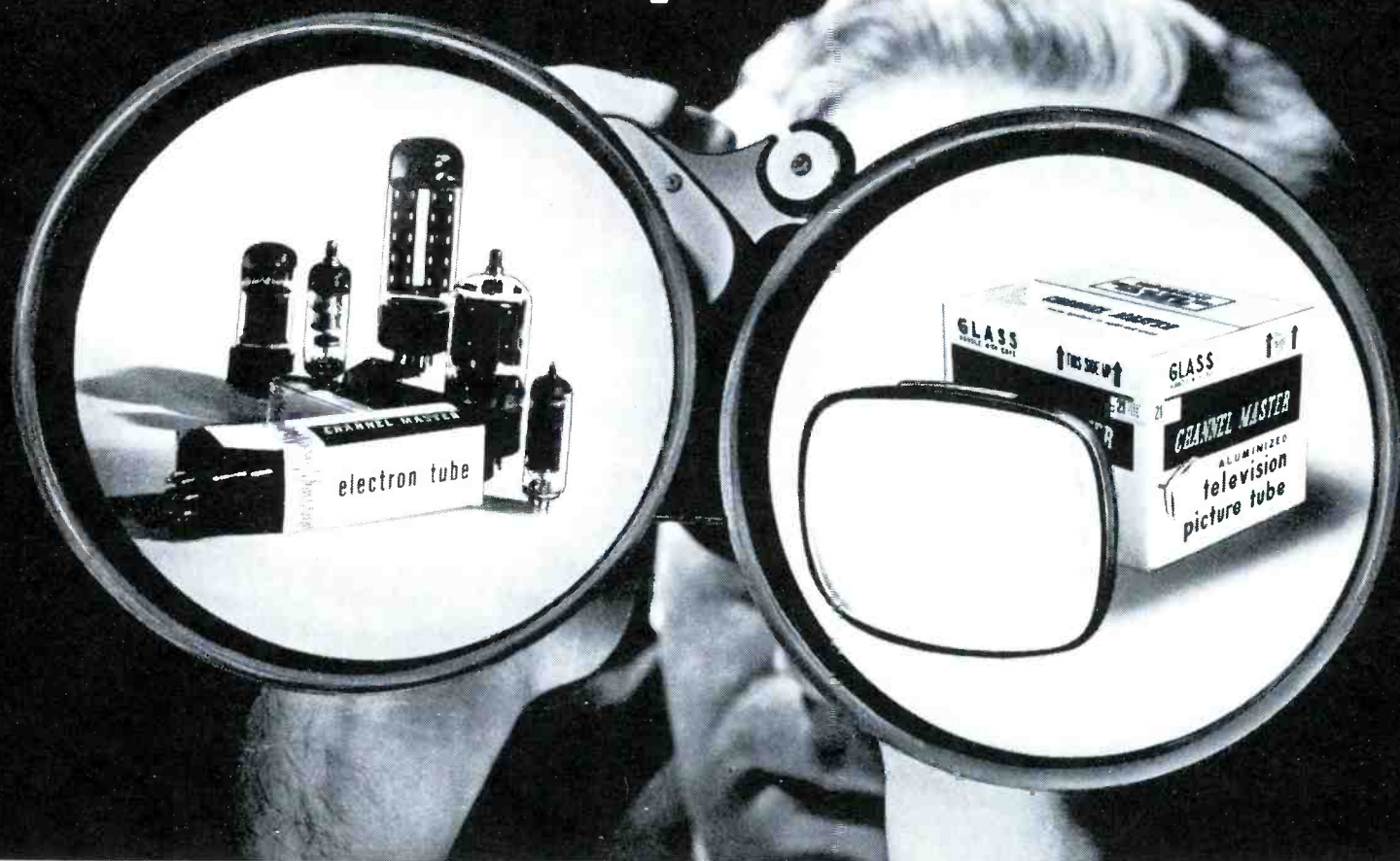

Fig. 1. Open peaking coil in video path will cause loss of highlights in picture.

FOCUS...on the new breed of tube leadership



The only receiving tubes that offer protected full profits.

It isn't just that Channel Master Premium Quality Receiving Tubes are top performers. The fact is no other tubes give you higher profits—plus **ironclad** protection. Because Channel Master sells only to legitimate independent dealers through distributors; **never** to cut-rate discount houses or drug store tube-testers. And don't forget our tube premium promotions: Truly outstanding gift values! (Your Channel Master distributor will be happy to give you full details on the latest.)

Now America's largest-selling replacement picture tubes.

Hard to believe, but—in two short years, Channel Master Replacement Picture Tubes have shot up to the No. 1 position in the replacement picture tube field. And for good reason. With Channel Master, you pick from the **most complete selection of tube-types in the industry.** (Especially important when you need a hard-to-come-by tube quickly—obsolete or modern.) And you get your tubes at the **lowest prices** of any national brand. The quality? Top-drawer. To be certain these longer-lived tubes stay brighter longer, we inspect each one 31 times.

Extra protection. Extra-dependable service. And extra profits. That's real leadership. And that's why so many dealers are finding it pays to focus on Channel Master as their first choice in tubes.



CHANNEL MASTER

ELLENVILLE
NEW YORK

Circle 15 on literature card

FACTS ABOUT



Be better prepared to select a correct replacement

by RUFUS P. TURNER

A good amount of electronic servicing consists of spotting and replacing defective filter capacitors. Compared with some of the exciting modern electronic devices, the filter capacitor is an unglamorous, work-horse type of component. But the service it performs is important to the operation of entire systems, so electrolytic capacitors must not be disparaged. Instead, the technician should have a good knowledge of both electrical and physical characteristics, and understand how they affect its operation.

Role of a Capacitor

Smooth DC power is needed for most electronic circuits. Batteries supply such power, but their use is not feasible except in solid state equipment with small power needs. The alternative is to rectify alternating current from power lines. But rectified AC is not smooth; it consists of half-cycles passed by the rectifier, and the job of the filter is to remove the ripples.

Filters consist of some combination of capacitors and choke coils, or of capacitors and resistors, although a capacitor alone may be used in some low-current power supplies. Whatever type of filter circuit is used, the smoothing action of the capacitor results from its ability to store a charge of electricity. The capacitor is charged by one peak of rectified AC, and it holds most of this charge while that half-cycle drops to zero. The time constant of the load is long enough that, before much of the charge can leak

off, the next half-cycle arrives to recharge the capacitor. The result is a nearly constant DC voltage. In this way, the ripples in the rectified AC are smoothed out.

Fig. 1 shows several common power supply filter circuits. The capacitor-input type (A and B) supplies the highest DC output voltage, because the input filter charges quickly to the input peak, and discharges slowly. The choke-input type (C) gives best voltage regulation, but at reduced DC voltage, because the filter charges more slowly through the input choke; thus, discharge can start before the capacitor charge reaches the input cycle peak. The DC voltage output of the capacitor-input filter approaches the peak value of the AC input voltage (that is, $E_{dc} = 1.414E_{ac}$), while the

DC voltage output of the choke-input filter approaches the effective value of the AC input voltage ($E_{dc} = 0.637E_{ac}$).

The L-C circuits (A and C) provide best smoothing action because of the reactive effect of the chokes, but the R-C types (B and D) are adequate when the DC output current drain is low. Single-section filters are shown, but several sections may be cascaded for greater smoothing action.

The output of a filter network consists of a steady DC voltage and a slight AC component which is the ripple that remains after filtering. This composite voltage is shown graphically in Fig. 2.

Capacitor Characteristics

A capacitor has certain characteristics which must be considered for each specific application. Some of these characteristics are of particular importance in relation to filter capacitors, and will be discussed in logical sequence.

Capacitance

The circuits in Fig. 1 are low-pass filters. The L and C, or R and C values are chosen so the filter cutoff frequency is equal to approximately half the rectifier ripple frequency. The ripple frequency of a half-wave rectifier is equal to the power-line frequency; for a full-wave rectifier, it is twice the power-line frequency. This means that the ideal filter will block all frequencies above its cutoff frequency.

Because the power-line frequency is low, large capacitances, resistances, and inductances are needed. In an R-C filter, high resistance would introduce a serious voltage drop; and in an L-C filter, a very high-inductance choke coil with adequate current rating would be prohibitive in size. The solution is to hold the choke or resistor to a reasonable size and increase the capacitance value. The electrolytic capacitor makes this practicable by providing high capacitance in a relatively small space. Capacitance values between 8 and 80 mfd are common in filters used in 60 cps power supplies that provide DC

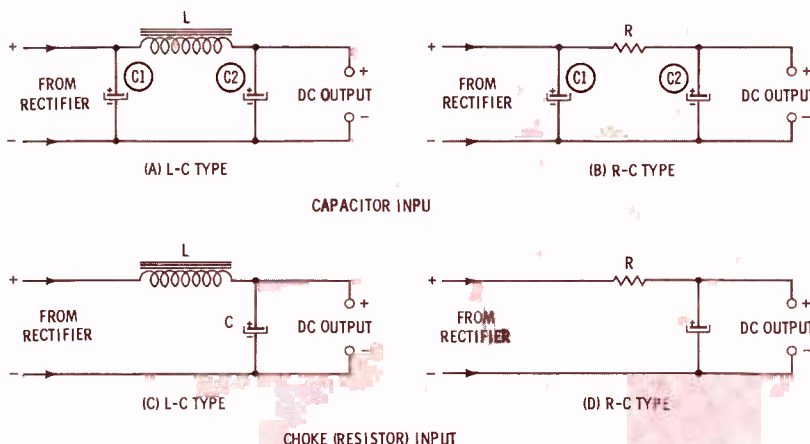
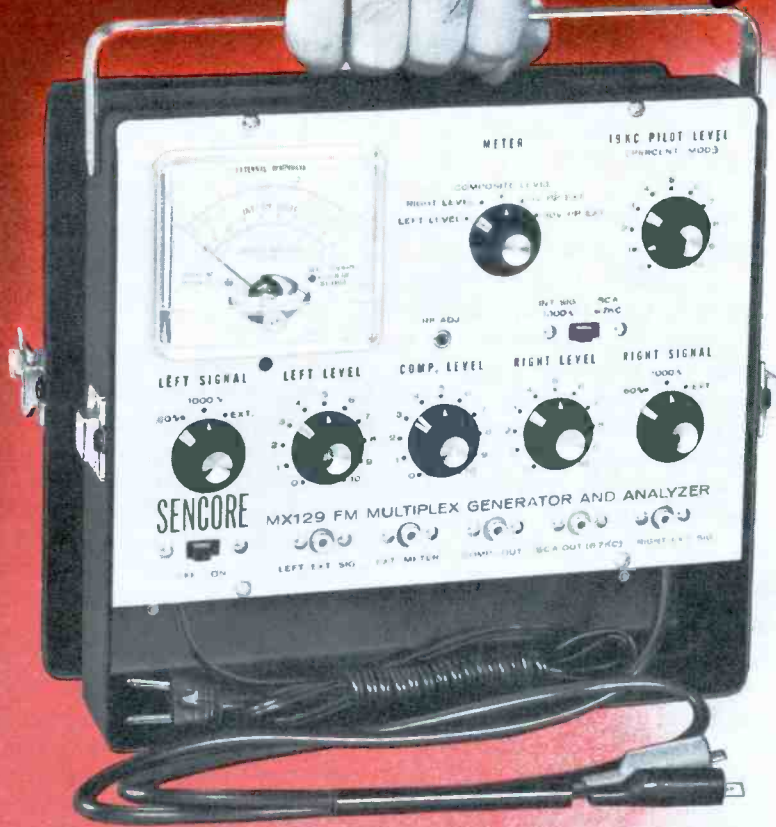

Fig. 1. Common power supply filter circuits show various ways to suppress ripple.

QUALIFY NOW FOR



FM STEREO SERVICE

19 TRANSISTORS
ALL CRYSTAL CONTROLLED
TRULY PORTABLE ONLY 7½ LBS.

\$169⁵⁰

SAVE HUNDREDS
OF DOLLARS

... with the ALL NEW **SENCORE** MX129 FM STEREO MULTIPLEX GENERATOR AND ANALYZER

It has been established by all Radio and TV manufacturers that you must have a generator of this type to service FM stereo receivers. Here is a new field just waiting for qualified men, a field that is growing as fast as color TV. Multiplex is simple to service with this generator. If you can service an FM receiver, you can service multiplex once you have the MX129.

Look at the outstanding features of this all transistorized Sencore unit and you will see why it is the most versatile, most portable, most trouble free unit on the market. It is just like having your own FM stereo transmitter on your bench or service truck. All signals are crystal controlled and instantaneous because there are no tubes to warm up. Powered by 115 volts AC to insure top performance at all times.

The MX129 produces all signals required for trouble shooting and aligning the stereo portion of the FM multiplex receiver and can be used as a stereo demonstrator by feeding in left and right audio signals into the jacks marked LEFT and RIGHT EXT. SIG. This unique feature will allow you to demonstrate stereo to the customer even when a stereo program is not being broadcast.

The MX129 becomes a complete trouble shooting analyzer with the addition of a meter calibrated in peak to peak volts and Decibels. No other equipment is required for checking channel separation or alignment. A jack marked EXT. METER is provided for connecting the meter to the stereo speakers or at other points after detection.

Here are the signals available on the MX129 for alignment, trouble shooting and analyzing:

- FM-RF carrier with composite multiplex audio signal just like that transmitted from the FM station: 38kc suppressed carrier, 19kc pilot and 67kc SCA signal. This signal available at RF output cable.
- Multiplex signal is formed by either 60 cycle or 1000 cycle internal tones for greater flexibility in testing.
- Full control over left and right channel amplitude (and therefore modulation). Built-in meter is used to set controls for equal modulation of FM carrier. Channels can be turned completely off when desired.
- 19kc pilot calibrated directly in percentage of modulation; can be generated separately for 19kc amplifier peaking by turning down left and right channels.
- External 67kc SCA (subscription) signal available at jack marked SCA OUT (67KC) for trap adjustment. This signal, not found on some high priced multiplex generators, is very important on new stereo receivers with adjustable 67kc traps.
- Composite signals, same as described above, available on jacks marked COMP. OUT for signal injection beyond the FM detector.

SENCORE

426 SO. WESTGATE • ADDISON, ILL.

Circle 16 on literature card

solid state reliability...

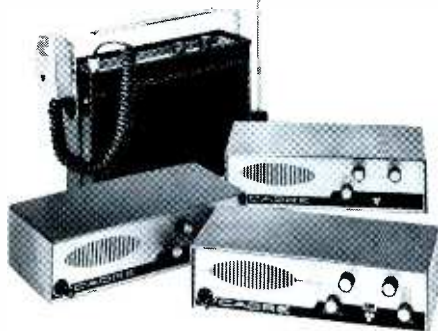

Cadre (CB Transceivers)

Solid state circuitry means that Cadre CB receivers can be bounced over rough roads in mobile installations; and can take plenty of rough use at base stations and in portable field use.

Solid state circuitry means that Cadre transceivers draw about as much power as an electric clock. Not only do auto or marine batteries last longer, but when batteries get low, Cadre solid state transceivers operate where others might not.

Reliability is only one reason why Cadre solid state CB transceivers are your best buy. Performance is another part of the story—plenty of transmission punch on 5 crystal-controlled channels—long distance reception with the dual conversion superhet receiver. And unwanted noise and adjacent channels are effectively suppressed.

FOUR POWERFUL SOLID STATE 5-WATT, 5 CHANNEL MODELS for every possible application—base station, mobile, field. New Cadre 510-A—AC/DC 23 channel manual tuning \$219.95. Cadre 515 same as 510-A less manual tuning \$199.95. Cadre 520 DC only with battery cable and mounting kit. For mobile and portable use from 12 volt batteries \$187.50. Cadre 525, model 520 in portable pack carrying case with built-in battery/power supply, recharger, AC cord and telescoping antenna for complete field portability. \$269.95.

FULL POWER, 1.5 WATT HAND HELD RECEIVER CADRE C-75 Solid state throughout. Two crystal-controlled channels. Sensitive receiver, powerful transmitter with one watt output to the antenna. \$109.95. Recharger and set of (2) nickel-cadmium batteries. \$31.85. Cartridge for (9) penlite cells. \$2.95.



CADRE INDUSTRIES CORP.
COMMERCIAL PRODUCT DIVISION □ ENDICOTT, NEW YORK □ AREA CODE 607, 748-3373. Canada: Tri-Tel Assoc., Ltd., 81 Sheppard Ave. W., Willowdale, Ont. Export: Morhan Export, 458 B'way, N. Y. 13, N. Y.

Circle 17 on literature card

output current up to several hundred milliamps. When output current of several amperes is required, a low-inductance choke (often only a few millihenrys) must be used; otherwise its size at this current rating would be enormous. Hence, to maintain low-frequency cutoff, the filter capacitance must be proportionately increased (100 to 10,000 mfd).

Capacitance and tolerance vary in electrolytic capacitors with the applied DC voltage. If the voltage is considerably below the capacitor's working rating, the capacitance is higher and the tolerance range is wider. For this reason it is desirable to test this type of filter capacitor with an instrument such as a bridge. Doing so will allow the simultaneous application of both a signal voltage and the correct DC polarizing voltage.

Working Voltage

Filter capacitors must be able to withstand safely the voltages applied to them. From Fig. 2, we see that across the capacitor is impressed not only the DC voltage, but also a superimposed ripple voltage (the AC component that remains after rectification and any preceding filtration). An electrolytic capacitor is rated in terms of DC working voltage (DCWV). The total voltage applied to the capacitor (DC plus peak AC) must not exceed this DCWV.

A filter capacitor often fails because it has been selected to withstand only the DC voltage in the circuit, with no consideration for the applied AC ripple which may be high enough to raise the total impressed voltage above the DCWV value. If there is any doubt, the peak value of the ripple voltage should be measured with a calibrated oscilloscope; an AC voltmeter is often unsatisfactory for this measurement, because the meter is calibrated with a sine wave and the ripple voltage is not sinusoidal.

For a safety factor, the DCWV of the filter capacitor should be somewhat higher than the total voltage in the circuit. For example, if the total voltage is 150 volts, use a 200 volt capacitor.

In any filter network, the first capacitor receives the highest ripple voltage. This accounts for the fact that it is the one that most often

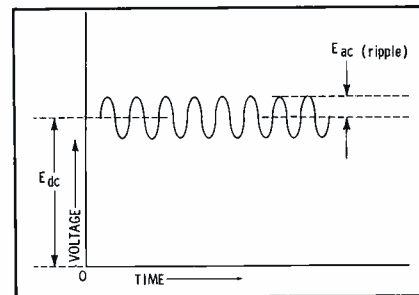

Fig. 2. Output of filter showing AC ripple.

blows out or becomes fatigued. Its short circuit can destroy the power-supply rectifier.

Leakage Current

No capacitor, whatever its type, contains only capacitance. The dielectric between the plates is never a perfect insulator, so there is some resistance between the plates. This is shown as parallel resistance R_p in Fig. 3. The plates, leads, and connections are not perfect conductors, so there is also some resistance in series with the plates. This is the series resistance R_s .

When voltage is applied to a capacitor, a proportional current flows through R_p , appearing as leakage between the plates. In nonelectrolytic capacitors (paper, mica, ceramic, plastic) the value of R_p is so high that the minute leakage may be detected only with special instruments. The electrolytic capacitor, however, normally has considerable leakage current. The permissible maximum for this current is seldom given in capacitor manufacturer's literature. However, a good rule of thumb is that the DC leakage current should not exceed 0.1 ma per microfarad when the rated DCWV is applied to the capacitor.

Power Factor

Since, as shown in Fig. 3, a practical electrolytic capacitor is actually a resistance-capacitance network, it appears as a certain impedance at

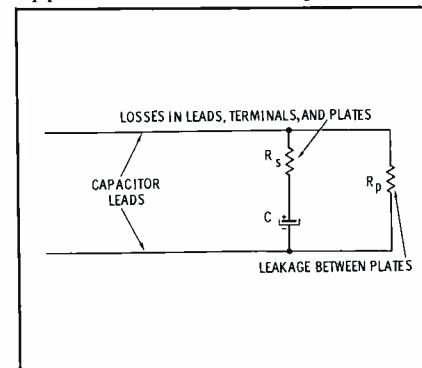
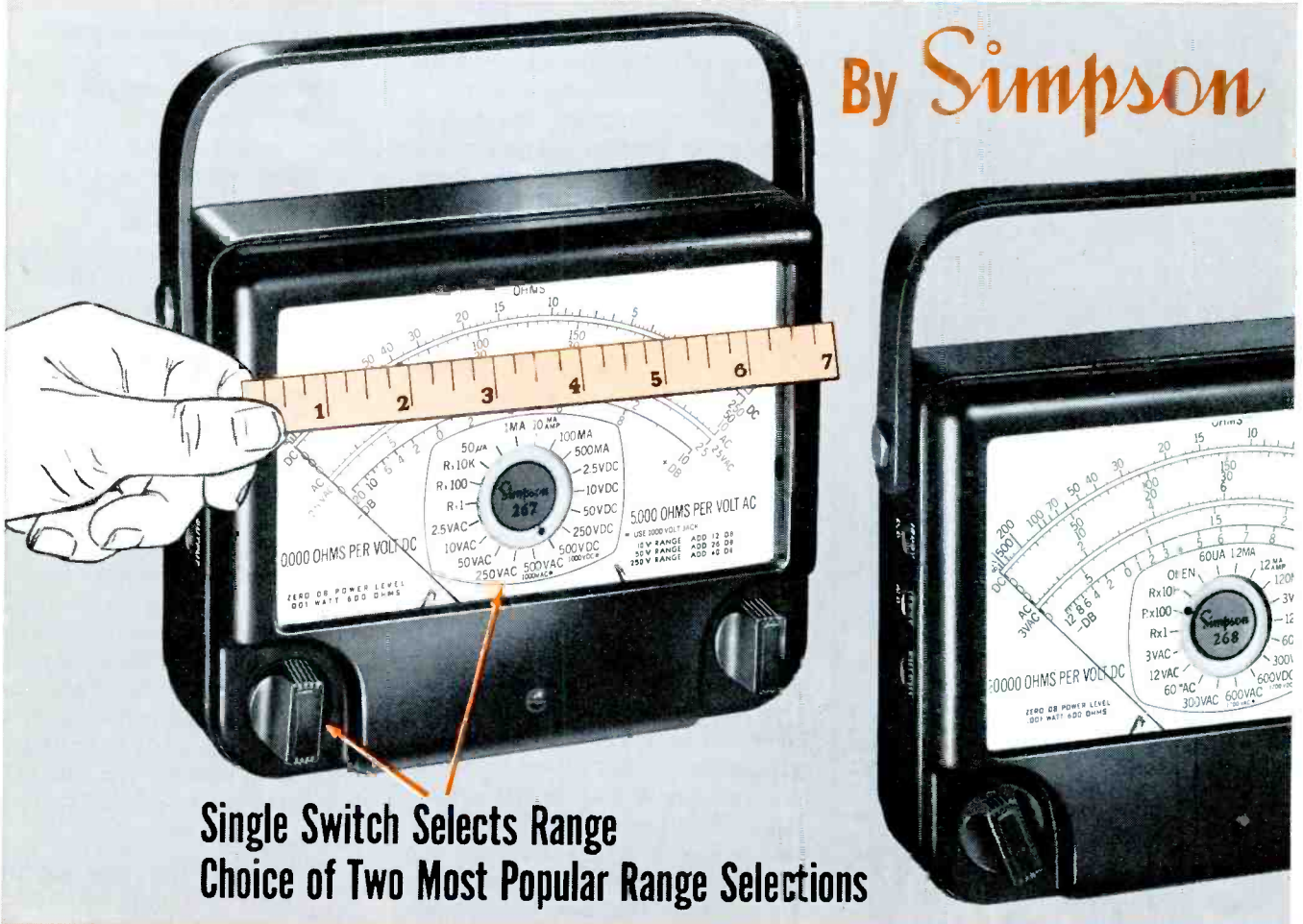

Fig. 3. Equivalent circuit of a filter capacitor showing series and parallel resistance.

7-INCH VOMs AT \$54⁹⁵

By Simpson



**Single Switch Selects Range
Choice of Two Most Popular Range Selections**

From whom but Simpson (makers of the world famous 260 Volt-Ohm-Milliammeter) could you expect testers like Models 267 and 268?

Although their price tags fall in the same area as other makes with small 4½" meters, Models 267 and 268 give you big, easy-to-read 7" meters plus quality features such as: *self-shielding*, core-type movements with spring loaded jewels . . . single-switch range selection . . . black and red scales that are spread out for close repetitive reading . . . Adjust-A-Vue handles . . . plus all the rugged, stay-put accuracy that you *expect and get from Simpson*.

Vital statistics for Models 267 and 268 are: DC sensitivity, 20,000 ohms per volt; AC, 5000 ohms per volt. Accuracy: DC volts, ±3% of full scale; AC volts, ±5% of full scale.

Have your distributor bring one out for trial.

Choice of 250 or 300 Volts

	Model 267	Model 268	
DC VOLTS	0-.25/2.5/10/50/250/500/1000	0-3/12/60/300/600/1200	
AC VOLTS	0-2.5/10/50/250/500/1000	0-3/12/60/300/600/1200	
DC MICROAMPERES	0-50	0-60	
DC MILLIAMPERES	0-1/10/100/500	0-1.2/12/120	
DC AMPERES	0-10	0-12	
DB SCALE	-20 to +10 DB 1 MW in 600 ohms	-12 to +11 DB 1 MW in 600 ohms	
OUTPUT RANGES	AC Volt ranges to 250 V with .1 mfd condenser in series	AC Volt ranges to 300 V with .1 mfd condenser in series	
OHMS Ranges Ctr. Scale Value	RX1 12	RX100 1200	RX10K 120,000

Also Available: carrying cases, high-voltage multipliers, and special types of test leads.

**Model 267 or 268
complete with test leads
and operator manual**

\$54⁹⁵

Simpson

SIMPSON ELECTRIC COMPANY

5209 W. Kinzie St., Chicago 44, Illinois

Phone: EStebrook 9-1121 (Area Code 312)

In Canada: Bach-Simpson Ltd., London, Ontario

See Your Distributor Also
For Simpson's Famous 260.
Outsells All Other VOMs Combined.
Still Only \$48.95



Famous around the world...260® VOM

1



Genuine, fresh Little Devil® resistors (on "Tally Tape" or in Cabinet Assortments)

2



Quality 2-watt pots, Type AB



Gold-bonded germanium diodes at "entertainment diode" prices.

3 WAYS TO MAKE SURE IT STAYS FIXED

You're always safe, always sure with any of these three quality replacements. Why be otherwise? Repair jobs that boomerang cost you hard-earned profit. Little Devil® resistors come in 1/10, 1/4, 1/2, 1, and 2 watts from 2.7 ohms to 22 Megs . . . AB Pots from 50 ohms to 5 Megs in several shaft lengths and styles . . . gold-bonded diodes in ninety 1N types off the shelf.

Call your distributor for the latest Ohmite Stock Catalog 30.

Be right with

OHMITE

RHEOSTATS · RESISTORS · VARIABLE TRANSFORMERS · TANTALUM CAPACITORS · TAP SWITCHES · RELAYS · R. F. CHOKES · SEMICONDUCTOR DIODES

Circle 19 on literature card

the ripple frequency. Any measurement of capacitor quality must therefore take into consideration the ratio of the desired capacitance to the undesired resistance. The measurement of *power factor* does this.

Power factor is the ratio of series resistance R_s to impedance Z ($P_f = R/Z$); the capacitance of the filter capacitor is included in the Z factor of the fraction. Since it is stated as the fraction of input power dissipated as heat loss, the lower the power factor, the better the capacitor.

High Frequency Impedance

The output filter capacitor must have low impedance to audio frequencies when the supply powers audio equipment, or to radio frequencies when the filter supplies RF equipment; otherwise inadequate decoupling and consequent signal loss will occur. Low impedance is achieved by (1) selecting a capacitance whose reactance is low compared to the reactance or resistance of the circuit supplied by the filter, and (2) selecting a capacitor with low internal inductance.

In certain applications, such as FM-radio or television, it may not be possible to select a filter capacitor with sufficiently low internal inductance. In this event, the inductance will present a high impedance between the circuit and ground for any unwanted RF that may have gotten into the B+ line. This unwanted RF might then be coupled into other circuits, causing noise, oscillation, or distortion.

This problem can be overcome by bypassing the output filter capacitor for RF with a small mica or ceramic capacitor. This RF bypass is usually from 100 to 2000 mmf, the exact value being determined by circuit design.

Types and Connections

Any type of capacitor, electrolytic or nonelectrolytic, may be used in a filter, provided its capacitance is high enough for the frequency to be filtered. Electrolytic capacitors are preferred for lower frequencies because of their high ratio of capacitance to size. In filters where the cutoff frequency is not too low, permitting use of low capacitance (2 to 5 mfd), oil capacitors are sometimes used to avoid the leakage current of electrolytics.

Filter capacitors may be connected in parallel to increase capacitance, or in series to increase DC working voltage (the series connection decreases capacitance—Fig. 4). When electrolytic capacitors are connected in series, a 1 meg, 1 watt resistor should be connected in parallel with each capacitor to equalize the DC voltage applied to each. In the series circuit of Fig. 4B, the total working voltage equals the sum of the DCWV ratings of the individual capacitors.

Testing

There are various methods of testing filter capacitors, all of which have certain merits and disadvantages. The most popular methods (and the test equipment required) will be discussed here.

Replacement Method

The simplest filter capacitor test the service technician can make is substitution. This consists simply of (1) temporarily disconnecting one lead of the suspected capacitor, (2) substituting a good capacitor having identical characteristics, and (3) noting if the circuit is restored to normal operation. This can be done quickly and conveniently with a suitable capacitor substitution box, or with a tubular-type unit whose leads have been equipped with clips.

Capacitor Bridge

The service-type capacitor bridge will check not only capacitance (with rated DCWV applied to the capacitor), but also power factor and leakage. The bridge is superior

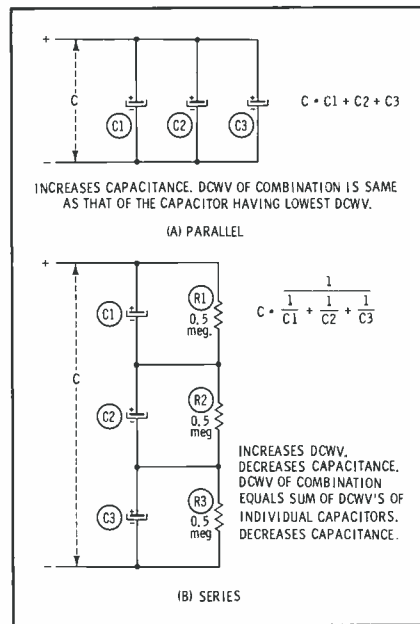

Fig. 4. Capacitance or DCWV can be changed by connecting capacitors in parallel or series.



PROOF OF 119 SUCCESS STORIES!

119 INDEPENDENT SERVICEMEN ASSURED THEIR LIFE'S FUTURE with the LAFAYETTE ASSOCIATE STORE PROGRAM

What Are You Waiting For--

You're in business for yourself, probably an independent serviceman like those other 119 businessmen. You have a basic knowledge of radio, television or electronics, and most of all you have ambitions to become a true success story—with your own profitable business, a respected place in your community, and security for your family.

You owe it to yourself, and your family, to investigate the Lafayette Associate Store Program.

This Is What We Offer You:

1. **Business Stability**—Lafayette Radio Electronics has been in business for 43 years. You'll cash in on this established reputation.
2. **Product Diversification**—You can sell the tremendous variety of products that Lafayette offers—hi-fi stereo, citizens band, tape recorders, radios, tools, radio and T.V. parts, hobby supplies, and much more. You'll attract more customers than you ever thought possible.
3. **Advertising Support**—Year 'round advertising, publicity, public relations and promotional campaigns have established Lafayette and its franchised dealers as America's primary source for hi-fi and electronics.
4. **Protected Territory**—Yours will be the ONLY franchised Lafayette Radio Electronics Associate Store in your marketing area.
5. **Marketing Guidance**—Our program helps you set up a complete operation. We'll help you select the right location, or evaluate your present one, design your store for maximum profit and assist in selecting your inventory. We'll show you how to deal with customers, how to hold a loyal following, how to build a successful business and maintain it. We will always be available to help you in any way possible. In short, we want you to be a Lafayette Success Story.

We are looking for a limited number of men who want to become part of America's largest and most successful Electronics Associate Store program, who are willing to invest \$10,000 to \$30,000 to make a new business career for themselves.

Mail the coupon for complete information without obligation. What are YOU waiting for!

Lafayette Radio Electronics Corporation

Dept. PFB-4

111 Jericho Turnpike, Syosset, L. I., New York

Mr. Robert Laub

Please send me full information on how I can own my own profitable business. I understand there is no obligation.

Name

Address

City Zone State

Circle 20 on literature card

New sound symbol to think about . . .

remember . . .

look for . . .

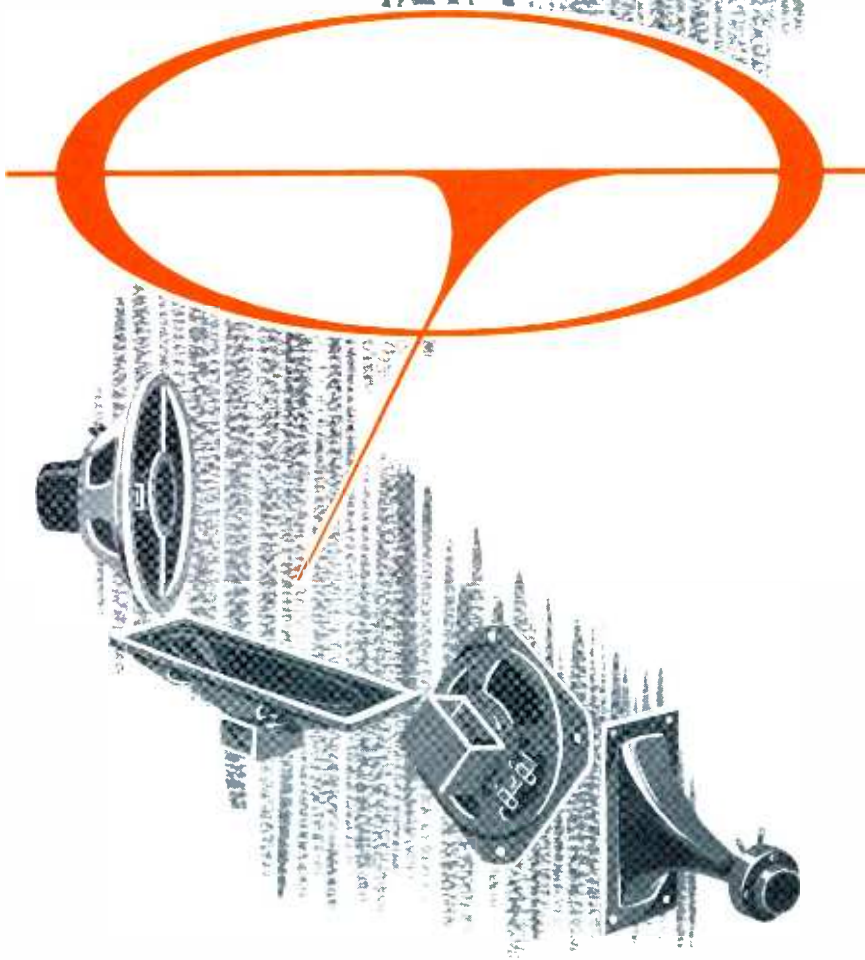

This is the symbol of the Oxford Transducer Company. It stands for quality, service and integrity . . . a good company to do business with.

It represents the time, talent, experience and devotion of an entire company whose sole objective is to build the world's finest loudspeakers. And this we have done.

The Oxford symbol means

full factory support, with a comprehensive advertising and merchandising program to insure maximum profits for you . . . prompt delivery . . . inventory protection . . . and a complete product line.

Combine these good business policies with the finest loudspeakers available, and you can see what the Oxford symbol means to you.



OXFORD TRANSDUCER COMPANY

Division of OXFORD ELECTRIC CORPORATION

2331 North Washtenaw Ave. • Chicago 47, Illinois

Circle 21 on literature card

to many other instruments for checking filter capacitors, since its test conditions more nearly approximate actual capacitor operating conditions.

Capacitance Meter

The direct-reading capacitance meter (also called microfarad meter) is available both as a separate instrument and as one of the functions in some service-type multimeters. The capacitance meter has the advantage that it gives direct indications, but it is often subject to considerable error when the power factor of the capacitor is poor.

In-Circuit Tester

This instrument saves considerable troubleshooting time, since it allows the filter capacitor to be checked without disconnecting it from the circuit. It primarily tests capacitor condition (good or bad) rather than indicating capacitance, power factor, or leakage current. It is helpful, however, for rapid, practical troubleshooting.

Ohmmeter Test

In the absence of other, more suitable equipment, an ohmmeter may be used for a limited check of filter capacitor condition: (1) First discharge the capacitor by temporarily short-circuiting its terminals. (2) Connect the ohmmeter (set to a high-resistance range, such as Rx10K), observing correct polarity. (3) If the capacitor is shorted, a steady, low resistance reading is obtained. (4) If the capacitor is open, no reading is obtained (infinite resistance). (5) If the capacitor is good, the resistance reading will first be low, then will slowly increase as the capacitor charges. It should reach at least 50K.

Summarizing

The service technician must first know what the filter capacitor is supposed to do, and then have a knowledge of characteristics that enable the capacitor to accomplish its purpose. If he can recognize the symptoms a faulty filter can cause, he can quickly proceed to the testing, and ultimate replacement of the bad component.

Thoughtful application of the facts in this article will save much time (usually wasted in trial-and-error experimenting) and allow the technician to do a more efficient and thorough job of servicing. ▲

ANOTHER GREAT ADDITION TO THE FAMOUS SERIES OF B&K ANALYSTS

SIMPLIFIES AND SPEEDS TV SERVICING

NEW!



Compact Model 1074 TELEVISION ANALYST FOR BLACK & WHITE and COLOR

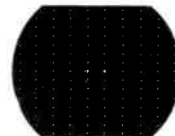

Dot Pattern



Crosshatch



Vertical Lines



Horizontal Lines



Color Pattern

Here is an exciting new addition to the famous B&K series of Television Analysts—*designed to give every service technician a faster, easier way to service more TV sets!*

The compact "1074" gives you a complete TV signal generating source of your own. Using the B&K *point-to-point signal injection technique*, you can isolate and pinpoint any performance problem for quick correction.

By injecting your own signals, with a visual check on the TV screen, *you can easily signal-trace and troubleshoot any stage* throughout the video, audio, r.f., i.f., sync and sweep sections of black & white and color television sets.

It becomes much easier to find and fix "tough dogs," and troublesome intermittents, as well as to solve other general TV set troubles—to the satisfaction of your customer, and to your own profit.

Net, \$24995

Supplies complete r.f. and i.f. signals, with pattern video and tone audio. Video signals are switch selected for fast, visual troubleshooting. Provides FM modulated 4.5 mc sound channel, with built-in 900 cycle tone generator. Provides composite synchronizing signals. Provides separate vertical and horizontal plate and grid driving signals to check complete output circuit and interrelated components. Many other features.

Makes it Easy to Set-up and Service Color TV

Provides dot pattern, crosshatch, vertical lines, horizontal lines, burst signal and individual colors (Green, Blue, B-Y, R-Y, Red, I, and Q) one at a time on the TV set—all crystal controlled for maximum accuracy. Color phase angles are maintained in accordance with NTSC specifications. Thin lines and high stability assure fastest, easiest convergence and linearity adjustments. Color display makes demodulator alignment extremely simple.

Time-Saving, Money-Making Instruments Used and Preferred by Professional Servicemen Everywhere.



Model 375 Dynamic Automatic VTVM



Model 360 V O Matic Automatic VOM



Model 700 Dyna-Quik Tube Tester



Model 850 Color Generator



Model 445 CRT Tester Rejuvenator

See Your B&K Distributor
or Write for Catalog AP21-R



B&K MANUFACTURING CO.

DIVISION OF DYNASCAN CORPORATION

1801 W. BELLE PLAINE AVE. • CHICAGO 13, ILL.

Canada: Atlas Radio Corp., 50 Wingold, Toronto 19, Ont.

Export: Empire Exporters, 253 Broadway, New York 7, U.S.A.

you can
MANAGE
for
profit

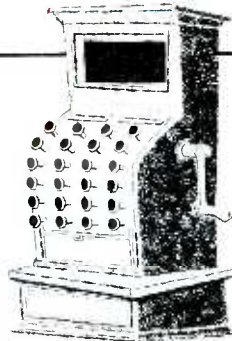

Hundreds of technicians have become expert with the scope, thousands have mastered the technique of neat soldering, and many can converge a color set with a few adept twists of the controls. These are accomplishments of which they can well be proud, and almost every service technician in the business has at least *one* such skill at which he is expert—above average. But there is one technique which still escapes many independent service shop owners—that of making a fair profit!

Profits can be elusive. Sometimes they are plentiful, sometimes skimpy; occasionally they are easy to find, but more often they can't be found at all. As a consequence, some shop owners never know for sure whether they are making a profit or not. Others feel sure they are, but don't know how much. If they know the amount, they aren't always convinced the amount is sufficient for the time spent, the money invested, or the amount of business being transacted. Profits are hard to account for, in many instances.

If you are making plenty of profits and you know it, you've little to gain by reading this article. If, on the other hand, you are among the group who wonder why you sometimes haven't enough to pay all the bills, read on—you may discover techniques that will serve you well during the coming months.

Table I

	Parts	Service	Both
GROSS SALES:			
Radio-TV	\$ 675.85	947.50	1623.35
Two-Way Radio	586.90	1312.80	1899.70
Appliances	873.00	757.60	1630.60
TOTALS:	\$2135.75	3017.90	5153.65

To Earn A Profit . . .

Before you can do anything to increase profits, you must know exactly how much profit you presently make—if any—and where it comes from. To this end, it is merely repetitious to mention the importance of record-keeping; few businessmen in any field would try to get along in our modern economy without records of their business transactions.

Therefore, instead of repeating this important prerequisite, we're going to discuss what you can do with your records. In other words, what can they tell you about making a profit?

To earn a profit, you must take in more money than you spend. Do you? A true profit is *over and above* a fair salary for your time and effort. Is yours? A satisfactory profit must equal or exceed the amount of interest you could get by putting your money in a savings account. Does it? If the answer to any of these questions is "No," then you need more skill in the game of management. Don't sell yourself short; your profit-making ability is equally as important to your business as being able to fix every tough-dog set that is placed in front of you.

Analyzing Your Records

Let's repeat: To earn a profit, you must take in more money than you spend. This sounds trite, but it gives you the clue to two ways you can manage to raise your profits. You can *increase* the amount of money you take in, or you can *reduce* the amount you spend. There are many ways to do both, but you need to concentrate on which specific way will benefit *you* most. No doubt your income appears, in many ways, as great as it could be. But if you can ferret out just a few possibilities for extra income, without increasing your investment or time expenditure, you are simply putting profits into your pocket.

Your profit-loss statement is probably the most informative tool you can use, providing that you know how to interpret it and use it to find ways of increasing profits. In a previous article ("Cost of Doing Business"—April, 1962), we showed you how to develop such a statement. Now let's delve into the finer points of profit-hunting in the statement. We'll start with income.

Table I is representative of how the income portion of a profit-loss statement can be broken down for close analysis. This particular chart came from a shop that specializes in different types of service, and sells no sets directly.

Examining one category, Radio-TV, we can look for facts that might help us discover a way to increase income under this category. First, we notice that Service income is greater than Parts revenue by a ratio of approximately 3:2. Analyzing this, we'd think: Is service naturally our biggest dollar volume, or have parts sales been neglected? Could we bring Parts income up to a level equal to Service without spending any appreciable amount of extra time on jobs? Are we selling accessories such as indoor antennas, CRT brighteners, set couplers, phono needles, and similar items whenever possible? Are we failing to convince customers who need picture tubes that *now* is the



Tips for Technicians

Mallory Distributor Products Company
 P.O. Box 1558, Indianapolis 6, Indiana
 a division of P. R. Mallory & Co. Inc.

Why Mallory Mercury Batteries work better in transistor radios

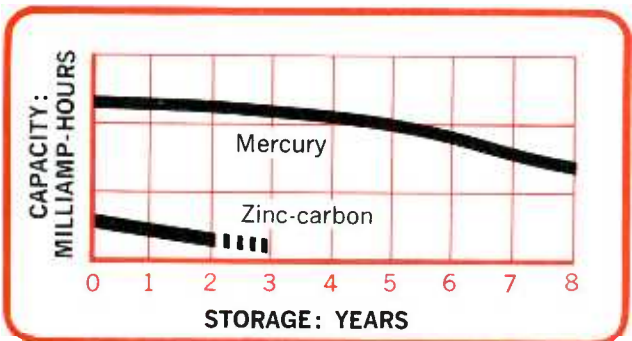
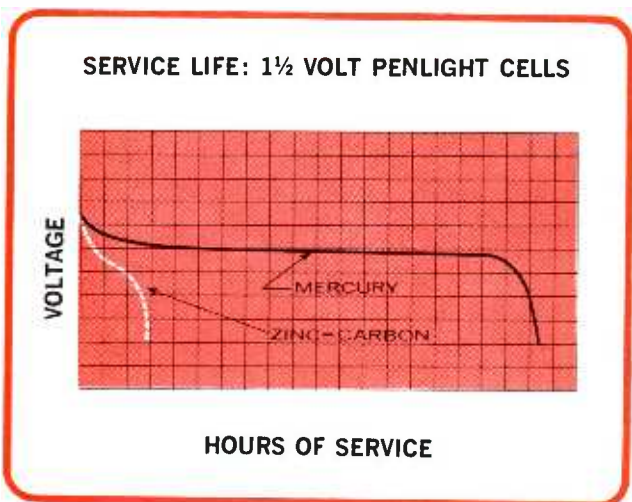
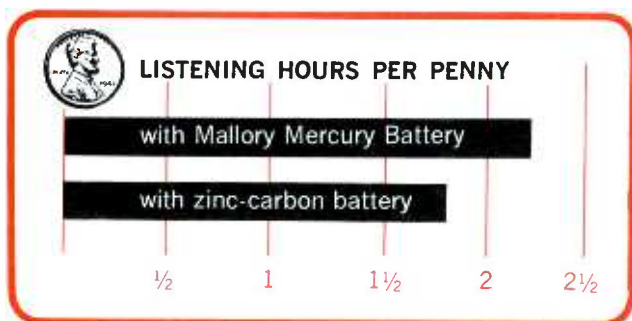

There are a lot of good reasons why more and more people are using mercury batteries in their transistor radios. And the reasons boil down to this—they're a better value, and they give better performance.

To get a comparison between mercury batteries and ordinary zinc-carbon batteries, let's look at a typical transistor radio. This radio uses size "AA" penlight batteries and has a current drain of 15 milliamperes. The Mallory Mercury Battery is the ZM9 and the zinc-carbon type would be the NEDA type 815. The ZM9 retails for 75¢ versus 20¢ for the 815. Got the picture?

Here's where the fun begins. The ZM9 will operate the radio for 165 hours versus only 35 hours for the zinc-carbon battery. This means that for one penny you'll get 2.2 hours of listening pleasure using the ZM9 versus 1.75 hours for the zinc-carbon battery. In other words, it costs you 0.57 cents per hour to use the zinc-carbon compared to only 0.45 cents for the mercury battery.

We're not through yet. Let's get back to *listening pleasure*. The mercury battery has essentially a flat discharge curve. This means that it presents a more constant voltage to the transistors. Result: you don't have to keep turning the volume control up while you're listening AND the radio *sounds* better because there's far less distortion.

Had enough? There's one more important point. Suppose you put the batteries in the radio and use it only slightly. Those 20¢ zinc-carbon batteries go "dead" in a few months whether you use them or not. But the mercury batteries can be stored 2 to 3 years and still deliver dependable power. Plus the fact that Mallory Mercury Batteries are guaranteed* against leakage in your transistor radio.

We've used this "Tip" to illustrate the superiority of Mallory Mercury Batteries in transistor radios. But this superiority extends to *thousands* of other applications. So whether you're building test equipment, heart-pacers, or satellites, see your Mallory Distributor. He has a Mallory Mercury Battery that will do exactly the job you want done.

*We guarantee to repair the radio and replace the batteries, free of charge, if Mallory Mercury Batteries should ever leak and damage a radio set. Send radio with batteries to Mallory Battery Company, Tarrytown, New York.



BETTER BUILT FOR BETTER PERFORMANCE

ANTENNACRAFT

Automatic Channel Selector
TV ANTENNAS

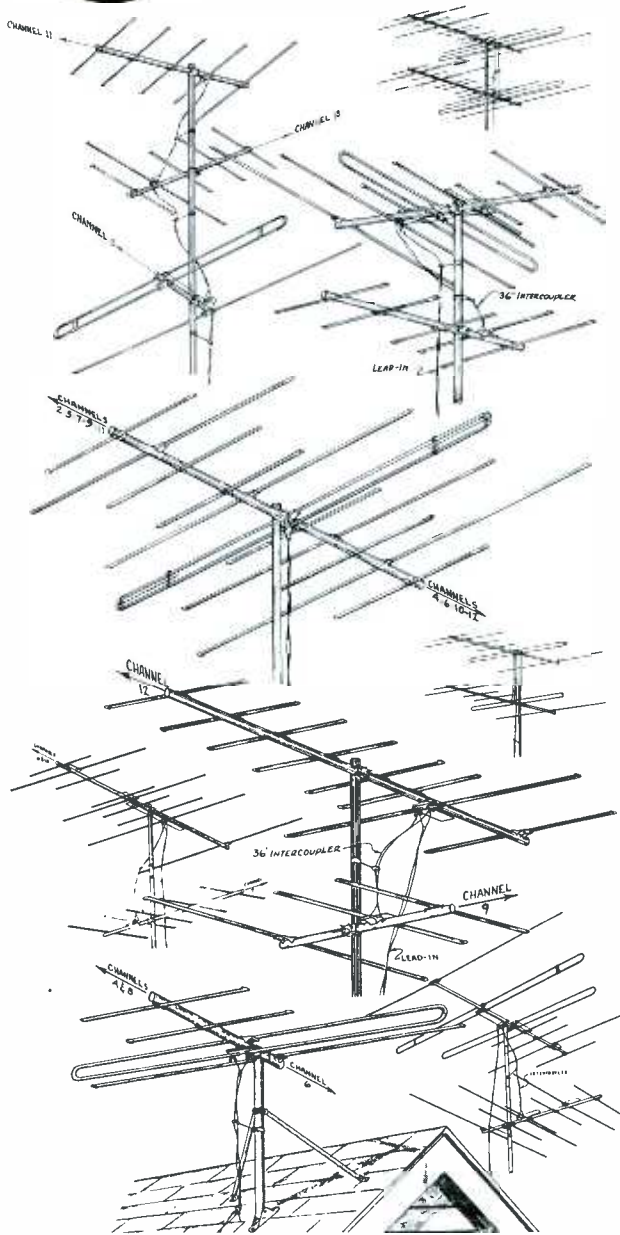

Ask us what's new with Antennacraft and we'll pour you an earful. There is something new every day - new antennas built for special jobs, jobs that no other antenna can do. Antennacraft customers all over the country are using our special antennas designed for their particular needs. Antennas that give ghost-free, snow-free performance on all available channels, not just the strongest signal, but even the ones that have been problems to receive come in sharp and clear.

Automatic Channel Selector TV Antennas are exactly as the term implies. Whether the antenna is designed for high, low or a combination of high and low band channels the signal is selected automatically to match the channel you tune to. There's no need for rotors, switches, couplers or other high loss electronic gadgets. There probably is an Automatic Channel Selector TV antenna, by Antennacraft, designed for your area, ask your distributor today.

Circle 24 on literature card

time to let us install them? Do we take advantage of the seasonal need for batteries?

In other words, the secret here is to find ways to bring up the dollar volume of Parts sales, without causing either a decrease in Service income or an increase in costs and expenses. The profit-loss statement merely reminds us of possibilities we can try.

After we've tried to increase our income in this manner, what then? How do we know if we're successful? Again, the profit-loss sheet can serve a useful function—compare the sales this month with those for last month in the category we're working on. Table II-A shows how this can be laid out for easy comparison. The profit-loss statement for each month can be tabulated in this manner, and the information is easy to compare. We're interested primarily in the Radio-TV information at the moment, so let's ignore the remainder of the chart.

Comparing current income in this category with that of last month, it would seem we've increased our parts income substantially. By comparing with the same month for last year, we offset the possibility that a seasonal upturn is responsible for the increase. Also, the fact that service revenue increased only slightly means that our work level probably stayed about the same, or perhaps increased slightly as the result of selling more accessories and installing them.

Extending the Theory





Does this work in other categories? Let's go back to the second category in our Table I sales chart—Two-Way Radio. The ratio between service and parts income in this category is large; it is more than 2:1.

Analyzing the situation once again, we come up with questions like: Is this a normal ratio for this type

Table II-A
Sales Breakdown Comparison

	Parts	Service	Both
Radio-TV			
This month	\$ 842.75	973.70	1816.45
Last month	675.85	947.50	1623.35
Mo. last year	632.25	848.60	1480.85
Two-Way Radio			
This month	602.70	1720.35	2323.05
Last month	586.90	1312.80	1899.70
Mo. last year	439.80	856.60	1296.40
Appliances			
This month	923.85	793.45	1717.30
Last month	873.00	757.60	1630.60
Mo. last year	904.65	806.20	1710.85
Totals			
This month	2369.30	3487.50	5856.80
Last month	2135.75	3017.90	5153.65
Mo. last year	1976.70	2511.40	4488.10

Plan your paging/talk-back speaker installations around University ...the most complete line.

APPLICATION	REQUIREMENT	RECOMMENDED SPEAKER	SPECIFICATIONS
Complete coverage for small areas with low ambient noise levels. Spot coverage to assure uniform sound volume in large systems.	Wide dispersion. Good frequency response. Weatherproof. Compact size. *OLB	 UNIVERSITY MODEL MIL-A	7.5 watts 350-13,000 cps 120° dispersion 7 $\frac{1}{8}$ " dia. 6 $\frac{7}{8}$ " deep In 4, 8, and 45 ohm impedances.
Same as above and where overhead obstructions are encountered.	Same as above but with greater control of dispersion pattern, reducing reverberation and spill over. *OLB	 UNIVERSITY MODEL CMIL-A	7.5 watts 350-13,000 cps 120° x 60° dispersion 6 $\frac{1}{4}$ " high, 9 $\frac{1}{2}$ " wide, 8 $\frac{1}{2}$ " deep In 4, 8, and 45 ohm impedances.
Coverage of sizeable areas with moderate ambient noise level. Amusement parks, warehouses, loading docks, portable P.A. systems.	High power handling capacity, high efficiency, greater low frequency response. Utmost reliability. Weatherproof. *OLB	 UNIVERSITY MODEL IB-A	25 watts 250-13,000 cps 90° dispersion 10 $\frac{1}{4}$ " dia., 9" deep In 4, 8, and 45 ohm impedances.
Same as above and where overhead obstructions are encountered.	All of the above, but with exclusive University Wide Angle horn for reducing reverberation. *OLB	 UNIVERSITY MODEL CIB-A	25 watts 250-13,000 cps 120° x 60° dispersion 7 $\frac{3}{8}$ " high, 14" wide, 12" deep In 4, 8, and 45 ohm impedances.
Ceiling suspension of speakers to cover wide area. Using minimum number of units. Factories, department stores, depots.	Uniform 360° sound dispersion. Built-in driver. High power handling capacity. *OLB	 UNIVERSITY MODEL IBR-A	25 watts 300-10,000 cps 360° dispersion 13" dia., 10 $\frac{1}{4}$ " deep In 4, 8, and 45 ohm impedances.

*OLB - Patented University Omni-Lok Bracket directs and locks speaker in any plane with a twist of the wrist.



University paging/talk-back speakers offer high microphone sensitivity for reliable talk-back communications. Their rugged construction assures lifelong dependable operation. Above all, University "High A" (High Audibility) engineering assures a degree of intelligibility that has never been matched in speakers of this type. For free catalog, write desk PR-2, LTV UNIVERSITY DIVISION, Oklahoma City, Oklahoma.

LTV UNIVERSITY

A DIVISION OF LING-TEMCO-VOUGHT, INC.
9500 West Reno, Oklahoma City, Oklahoma

Circle 43 on literature card

Communications, mobile radio...

A First Class FCC License

...or Your Money Back!

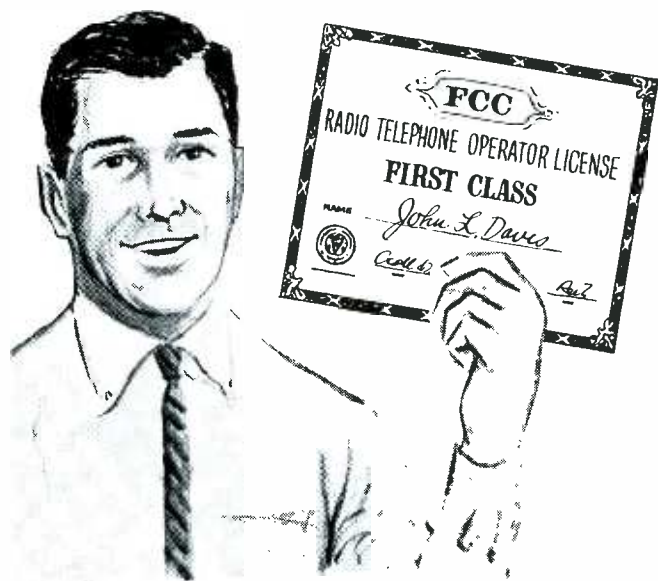

Your key to future success in electronics is a First-Class FCC License. It will permit you to operate and maintain transmitting equipment used in aviation, broadcasting, marine, microwave, mobile communications, or Citizens-Band. Cleveland Institute home study is the ideal way to get your FCC License. Here's why:

Our training programs will *quickly* prepare you for a First-Class Commercial Radio Telephone License with a Radar Endorsement. Should you fail to pass the FCC examination after completing your course, you will get a *full refund* of all tuition payments. You get an FCC License . . . or your money back!

You owe it to yourself, your family, your future to get the complete details on our "proven effective" Cleveland Institute home study. Just send the coupon below TODAY. There's no obligation.

MAIL COUPON TODAY FOR FREE CATALOG

Cleveland Institute of Electronics

1776 E. 17th St., Dept. PF-9
Cleveland 14, Ohio

Please send FREE Career Information prepared to help me get ahead in Electronics, without further obligation.

CHECK AREA OF MOST INTEREST -

- | | |
|---|--|
| <input type="checkbox"/> Electronics Technology | <input type="checkbox"/> First-Class FCC License |
| <input type="checkbox"/> Industrial Electronics | <input type="checkbox"/> Electronic Communications |
| <input type="checkbox"/> Broadcast Engineering | <input type="checkbox"/> _____ other _____ |

Your present occupation _____

Name _____ Age _____
(please print)

Address _____

City _____ Zone _____ State _____

Accredited Member National Home Study Council

How to Succeed in Electronics

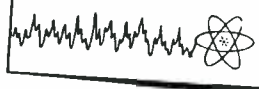

of business? Are there additional possibilities for parts and accessories sales, or is the market largely confined to tubes and components replaced in the run of ordinary servicing? How could we create an accessory market among our customers? If servicing is truly the major source in this type of business, would we be better off spending our time developing additional service income?

Deciding on the latter idea for this month, we set about developing new sources of service income. We succeed in landing an extra antenna-replacement job—replacing an old, corroded one with a new high-gain model. By a little leg work and promotion, we obtain a couple of new servicing accounts. Table II-B shows the results of this type of thinking—service income increased considerably.

Also of interest is the fact that the ratio of service to parts income increased, too. This could be construed as confirming the wisdom of our choice to concentrate on servicing income; apparently it is easier to build volume in two-way service than in parts. Maybe another month we can concentrate on building the two-way radio parts and accessories business, just to be sure we're not overlooking any good bets.

The point is that the manager of this operation is taking the time to *manage* his service business. His analysis of the entire service business takes only one night a month—the night after his bookkeeping service hands him his profit-loss statement. By analyzing his business in this manner, he has begun acquiring the skills of effective management. By concentrating his efforts on one category each month, he is developing both his ability and his business, one step at a time. He is *using* his business records to help him manage his way to greater profits.

Table II-B
Sales Breakdown Comparison

	Parts	Service	Both
Radio-TV			
This month	\$ 842.75	973.70	1816.45
Last month	675.85	947.50	1623.35
Mo. last year	632.25	848.60	1480.85
Two-Way Radio			
This month	602.70	1720.35	2323.05
Last month	586.90	1312.80	1899.70
Mo. last year	439.80	856.60	1296.40
Appliances			
This month	923.85	793.45	1717.30
Last month	873.00	757.60	1630.60
Mo. last year	904.65	806.20	1710.85
Totals			
This month	2369.30	3487.50	5856.80
Last month	2135.75	3017.90	5153.65
Mo. last year	1976.70	2511.40	4488.10

CHECKS AND REJUVENATES ALL PICTURE TUBES
WITHOUT ADAPTORS OR ACCIDENTAL TUBE DAMAGE

Featuring Automatic
Controlled
Rejuvenation

The All New SENCORE CR125 CATHODE RAY TUBE TESTER

An all new method of testing and rejuvenating picture tubes. Although the method is new, the tests performed are standard, correlating directly with set-up information from the RCA and GE picture tube manuals.

Check these outstanding features and you will see why this money making instrument belongs on top of your purchasing list for both monochrome and color TV testing.

Checks all picture tubes thoroughly and carefully; checks for inter-element shorts, cathode emission, control grid cut-off capabilities, gas, and life test. Checks all picture tubes with well filtered DC just like they are operated in the TV set.

Automatic controlled rejuvenation. A Sencore first, preventing the operator from over-rejuvenating or damaging a tube. An RC timing circuit controls the rejuvenation time thus applying just the right amount of voltage for a regulated interval. With the flick of a switch, the RC timer converts to a capacity type welder for welding open cathodes. New rejuvenation or welding voltage can be re-applied only when the rejuvenate button is released and depressed again.

Uses DC on all tests. Unlike other CRT testers that use straight AC, the CR125 uses well filtered DC on all tests. This enables Sencore to use standard recommended checks and to provide a more accurate check on control grid capabilities. This is very important in color.

No adaptor sockets. One neat test cable with all six



All six sockets, including latest color socket, on one neat cable.



Checks each gun individually in color tubes

sockets for testing any CRT. No messy adaptors, reference charts or up-dating is required. The Sencore CR125 is the only tester with both color sockets. (Some have no color sockets, others have only the older type color socket.)

No draggy leads. A neat, oversized compartment, in the lower portion of the CR125 allows you to neatly "tuck away" the cable and line cord after each check in the home.



MODEL CR128
For the man on the go. Same as above but in all steel carrying case . . . \$69.95

Model CR125 \$69.95

PS127 DELUXE WIDE BAND OSCILLOSCOPE AT A SURPRISINGLY LOW PRICE

This all new 5 inch oscilloscope offers the finest in performance, portability and appearance. Vertical amplifier frequency response, flat within 1 DB from 10 CPS to 4.5 mc and only 3 DB down at 5.2 mc insures true waveform reproduction. Vertical amplifier sensitivity of .017 volts RMS for one inch deflection on wide band (without band switching) is found only on scopes costing hundreds of dollars more. High input impedance of 2.7 megohms shunted by 99 mmfd (or 27 megohms with 9 mmfd with built-in low capacity probe), insures minimum circuit loading. For the first time, waveforms can be viewed in TV horizontal and vertical output circuits with the low capacity probe that will withstand up to 5000 volts peak to peak. To top that, the vertical amplifier attenuator controls are calibrated directly in peak to peak volts for fast direct reading of all peak to peak voltages.

Horizontal amplifier extended sweep range from 5 to 500 kc in five overlapping steps and frequency response from 10 CPS to 1 mc within 3 DB insures linear sweep and positive sync. External inputs for horizontal sweep and sync, intensity modulation, and smart two-toned case and "designer" styled controls brands the PS127 a truly professional oscilloscope.



PS127 \$169.50



Circle 27 on literature card

4 ways to increase your income

RCA Institutes, Inc. offers these four comprehensive home study courses especially designed to help build your income immediately!

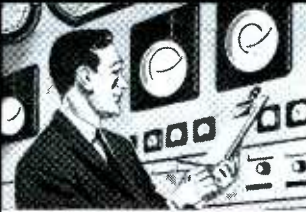
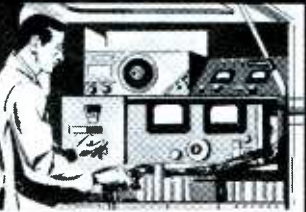
	
<p>COLOR TV Add Color TV Servicing to your skills with this up-to-the-minute home training course and take advantage of the growing profit potential in this area! Train under the direction of RCA...experts in Color TV.</p>	<p>TRANSISTORS You get the necessary background for semiconductor technology including characteristics of tunnel diodes, rectifiers and other solid state devices. Transistor trainer also available.</p>
	
<p>AUTOMATION ELECTRONICS Trains you for the many applications of automation electronics in industry and government including Photoelectronics, Digital Computer Techniques, Synchros and Servomechanisms, Automatic Control Systems, and many more!</p>	<p>MOBILE COMMUNICATIONS Trains you to service and maintain 2-way radio communications on land, sea, and air! Gives you the technical foundation for space communications!</p>

Take advantage of RCA's Liberal Tuition Plan. You only pay for lessons you order; and have no long-term obligations. Licensed by New York State Education Department. Approved for Veterans.

RCA INSTITUTES, INC.

A Service of Radio Corporation of America
350 West Fourth Street, New York, N. Y. 10014



The Most Trusted Name in Electronics

SEND THIS COUPON NOW FOR COMPLETE FREE INFORMATION

RCA INSTITUTES, INC. Home Study School, Dept. PF-24,
350 West Fourth Street, N. Y., N. Y. 10014

Without obligation, rush me free information on the following RCA Home Training Course: COLOR TV TRANSISTORS MOBILE COMMUNICATIONS AUTOMATION ELECTRONICS

Name _____ Age _____

Address _____

City _____ State _____ Zip _____

CANADIANS—Take advantage of these same RCA courses at no additional cost. No postage. No customs. No delay. Send coupon to: RCA Victor Company, Ltd., 5581 Royalmount Ave., Montreal 9, Quebec.

Circle 28 on literature card

Is It Worth the Time?

Take a look at the final month's totals shown in Table II-C, and judge for yourself. His total increase in business, resulting from steps he took after analyzing his income records, amounts to \$703.15. That is a total business increase of well over 10%, and in one month. Any business would be happy if they could report half that increase percentage in *one year!*

There is no doubt that increased management ability will increase your income far more than hours of extra work. You owe it to yourself and your business to take the time to learn this skill. It will be the most rewarding time you've ever spent.

Your results may not be so immediately spectacular; if they're not, it is a sign you're already a fairly good manager. But you can be sure that, if you analyze your business statements with a little imagination along the lines we've described here, you're bound for some surprising results.

More To Come

This subject is of such vital importance to servicemen, and to their continuation as independent businessmen, we plan to develop the other side of the management-for-profit coin in a future issue. Remember, to earn a profit, you must earn more and spend less. Next time, we will take you into the expense side of your profit-loss statement, and show you how the same creative management can help you cut down expenses. The result will naturally be more profits—and that's what you're in business for. ▲

Table II-C
Sales Breakdown Comparison

	Parts	Service	Both
Radio-TV			
This month	\$ 842.75	973.70	1816.45
Last month	675.85	947.50	1623.35
Mo. last year	632.25	848.60	1480.85
Two-Way Radio			
This month	602.70	1720.35	2323.05
Last month	586.90	1312.80	1899.70
Mo. last year	439.80	856.60	1296.40
Appliances			
This month	923.85	793.45	1717.30
Last month	873.00	757.60	1630.60
Mo. last year	904.65	806.20	1710.85
Totals			
This month	2369.30	3487.50	5856.80
Last month	2135.75	3017.90	5153.65
Mo. last year	1976.70	2511.40	4488.10

Any type of TV lead-in...

BELDEN makes it!

Your **BELDEN** distributor has it!



PERMOHM* 8285 . . excellent for color TV. Gives stronger, clearer UHF and VHF signals under conditions of extreme salt spray, industrial contamination, rain, and snow. 300 Ohm.



WELDOHM 8230 . . resists pulling, whipping, twisting. Weldohm has two and a half times the flexing life, and one and a half times the breaking strength of ordinary 300 ohm lead-in.



COAXIAL TRANSMISSION LINES—RG/U AND FOAM RG/U TYPES . . low-loss signal transmission for multiple TV installations such as motels.



STANDARD 300 OHM LINE 8225 . . low losses at high frequencies. Well suited for use with FM receiving antennas.



CELLULINE* 8275 . . installs easily . . no end sealing necessary. Has excellent resistance to sun, abrasion, and wind. Delivers strong UHF and VHF signals. 300 Ohm.



DECORATOR CABLE 8226 . . for interiors . . neutral color blends into decor of any room. No dark brown color to contrast with light carpets or walls. 300 Ohm.

Your Belden distributor has a complete line of Belden TV lead-in cable . . . in standard lengths for easy handling. He also carries microphone and shielded power supply cables; hi-fi, stereo, and phonograph cables; power supply cords; multi-conductor portable cordage; antenna rotor cables; hook-up wire; TV and cheater cords; aluminum ground wire . . . plus many other related items.



Better Built . . . Better Buy . . .

Belden
WIREMAKER FOR INDUSTRY
SINCE 1902 — CHICAGO

WELDOHM, PERMOHM, CELLULINE are Belden Trademarks
Reg. U.S. Pat. Off. *Belden Patents U.S. 2,782,251 and 2,814,666

cord sets and portable cables • electrical household cords • magnet wire • lead wire • automotive wire and cable • welding cable

Circle 29 on literature card



TYPE IL . . . why use old fashioned wax end-filled cardboard capacitors in radio repairs? Avoid call-backs with Planet type IL dual section tubular electrolytics . . . hermetically sealed in aluminum tubes with wax impregnated insulating jacket. Planet IL's are also available in 450 volts for TV servicing. Ask for them by type number at your distributor.

PLANET SALES CORP.

225 Belleville Ave.
Bloomfield, New Jersey

Circle 30 on literature card



INJECTORALL

THE NEEDLE DOES THE JOB!



TUNER CLEANER AND LUBRICANT
with . . .
INJECTOR NEEDLE

The leak-proof steel Injectorall Needle lubricates where you need it . . . you can reach hard-to-get at Wafers without pulling Tuners apart, or even removing Chassis.

The **BEST CLEANER** on the market today!

INJECTORALL CO. Brooklyn 14, New York

Circle 31 on literature card



Notes on Test Equipment

analysis of test instruments . . . operation . . . applications

by Stephen Kirk

Transmitter Helper

Working on transmitters "by guess and by gosh" is not a good way to make money, please your customer, or even satisfy yourself. Some means of measurement is essential if you want to do a good job and do it economically. An instrument that performs all the most important CB transmitter and antenna tests is the new *Port-A-Lab* built by Electronics Communications Inc. This unit has combined the necessary functions, even including a dummy antenna, inside a small, attractive black-and-silver box that measures 8" x 6" x 3 1/2" (Fig. 1).

The unit will measure standing-wave ratio (SWR) of the antenna and feedline when you connect the output of a CB transmitter through a short piece of coax cable to the TRANS connector, and the antenna feedline to the ANT connector—both located on the back of the instrument. A low SWR reading indicates a good match between the transmitter and the antenna system and that maximum power is being radiated by the antenna.

With this unit, you can also read the actual power output of a transmitter in the CB range. For this measurement, disconnect the outside antenna but leave the transmitter connected to the TRANS connector. Switch the dummy load (DL) switch (at the side of the unit) "on." This connects a network of carbon resistors, wired in series-parallel to give an impedance of 47 ohms and a rating of up to 50 watts intermittent, across the transmitter output. A sample voltage is taken from the center tap of this network, rectified, and fed through a filtering and calibrating network to the meter. The meter is calibrated in two ranges: 0-10 watts and 0-50 watts.

For low-power transmitters which may not use feedlines, or for plotting the radiation pattern of an antenna, or simply for checking whether any transmitter is or isn't operating, the *Port-A-Lab* also reads relative field strength of the radiated RF signal. The signal is picked up by a telescoping antenna on top of the unit; the selector switch must be turned to "RFS." An RF LEVEL control can be adjusted to keep the meter pointer on scale.

Modulation can be checked on the "RFS" position by plugging earphones into the MONITOR jack on the front panel.

Modulation percentage can also be read on the meter, and monitored aurally with headphones at the same time. The transmitter is connected to the unit, with the dummy load switched in. The selector switch is set to "CAL" and the

transmitter keyed. The RF LEVEL control is adjusted until the meter reaches the "CAL" mark on the meter scale. The selector switch is then set to "MOD." Speaking into the microphone should cause the meter to deflect upscale; a good transmitter will modulate up to 100% on peaks.

We connected the *Port-A-Lab* to a CB unit and measured the power output by switching in the dummy load and then keying the transmitter. The power output for this particular transmitter measured 3.1 watts on the *Port-A-Lab*, typical for a unit of the type tested. These readings are close enough to the true power that no service problem would ever occur.

Checking modulation with a *Port-A-Lab* was easy. We set the meter to the modulation calibration point and then talked into the microphone. On our transmitter, it was easy to get a full 100% modulation by speaking in normal voice about 1 1/2" from the microphone. On another transmitter, we had to get closer to the microphone to get 100% modulation. This test would quickly expose any transmitter that was not modulating enough to provide normal communications range.

We plugged a set of high impedance earphones into the MONITOR jack and listened to the modulation. This gave us a check as to whether or not the modulation was distorted.

We connected the *Port-A-Lab* to read SWR between the CB transmitter and a roof-mounted ground plane antenna. In this case we had almost no reflected power and the meter indicated a stand-



Fig. 1. Chrome-finished case houses several instruments for servicing CB transmitter.

SENCORE

SIMPLIFIES COLOR SERVICING

NEW! CA122

COLOR CIRCUIT ANALYZER

A simple approach to a complex problem

Here is an instrument that is designed to eliminate the guesswork in color TV servicing. A complete analyzer that provides all required test patterns and signals for testing from the tuner to the tri-color tube. Additional analyzing signals for injection at each stage including audio, video and sync, brings to life a truly portable and practical TV analyzer for on the spot service; virtually obsoleting other analyzers with the advent of color. Sencore's simplified approach requires no knowledge of I, Q, R-Y, B-Y, G-Y or other hard to remember formulas. The CA122 generates every signal normally received from the TV station plus convergence and color test patterns.

The CA122 offers more for less money:

TEN STANDARD COLOR BARS: The type and phase that is fast becoming the standard of the industry. Crystal controlled keyed bars, (RCA type) as explained in most service literature, offer a complete gamut of colors for every color circuit test.

WHITE DOTS: New stabilized dots, a must for convergence, are created by new Sencore counting circuits.

CROSS HATCH PATTERN: A basic requirement for fast CRT convergence.

VERTICAL AND HORIZONTAL BARS: An added feature to speed up convergence, not found on many other color generators.

SHADING BARS: Determines the ability of the video amplifier to produce shades (Y Signal) and to make color temperature adjustments. An important feature missing on other generators.

COLOR GUN INTERRUPTOR: For fast purity and convergence checks without upsetting color controls. Insures proper operation of tri-color guns, preventing wasted time in trouble shooting circuits when CRT is at fault.



A must for color . . .

a money maker for black and white TV servicing

ANALYZING SIGNALS: RF and IF signals modulated with any of the above patterns for injection into grid circuits from antenna to detector. IF attenuator is pre-set for minimum signal for each IF stage to produce pattern on CRT thus providing a check on individual stage gain. Sync and video, plus or minus from 0 to 30 volts peak to peak, have separate peak to peak calibrated controls for quick checks on all video and sync circuits. Crystal controlled 4.5 mc and 900 cycles audio simplify trouble shooting of audio circuits.

NEW ILLUMINATED PATTERN INDICATOR: A Sencore first, offering a rotating color film that exhibits the actual color patterns as they appear on color TV receivers. Locks in with pattern selector control.

You'll pay more for other color generators only.

Dealer Net. 187.50

NEW! PS120 PROFESSIONAL WIDE BAND OSCILLOSCOPE

A portable wide band 3 inch oscilloscope for fast, on-the-spot testing. An all new simplified design brings new meaning to the word portability . . . it's as easy to operate and carry as a VTVM. Though compact in size, the PS120 is powerful in performance: Vertical amplifier frequency response of 4 MC flat, only 3 DB down at 7.5 MC and usable to 12 MC, equips the technician for every color servicing job and the engineer with a scope for field and production line testing. AC coupled, with a low frequency response of 20 cycles insure accurate low frequency measurements without vertical bounce. Sensitive single band vertical amplifier; sensitivity of .035 volts RMS for one inch deflection saves band switching and guessing. Horizontal sweep frequency range of 15 cycles to 150 KC and sync range from 15 cycles to 8 MC (usable to 12 MC) results in positive "locking" on all signals. New exclusive Sencore features are direct reading peak-to-peak volts —no interpretation; dual controls to simplify tending; lead compartment to conceal test leads, jacks and seldom used switches. Rear tilt adjustment angles scope "just right" for easy viewing on bench or production line.

Size: 7" w x 9" h x 11 1/4" d. Weight: 12 lbs.

Dealer Net. 124.50
(with low cap. probe)

Kit. 74.50



A must for servicing color TV in the home . . . lowest priced broad band scope. All hand wired — all American made



**First
to deliver
uniform,
peak
performance
on all UHF
channels**

BLONDER-TONGUE GOLDEN DART

- Unique use of Log Periodic principle.
- Polar pattern & 10 db gain uniform across entire UHF spectrum—for sharp, ghost-free pictures.
- Full bandwidth, flat response ($\pm 1/2$ db) on all channels—excellent for black & white and color TV.
- Completely pre-assembled—nothing to snap-out, no screws to tighten—mounts to mast in seconds.
- Smallest, most compact of all UHF antennas (17" long by 2 1/2" deep)—easy to piggyback with any VHF antenna.
- Rugged unitized welded construction—no movable joints.
- For deep fringe area reception, stack two Darts with sturdy, easy-to-use stacking bars.
- Supported by intensive advertising program.

Now you can offer a complete UHF installation—antenna, UHF converter or TV booster (if needed)—from the leader in UHF.

Get details on the exciting new Blonder-Tongue UHF Dart today.

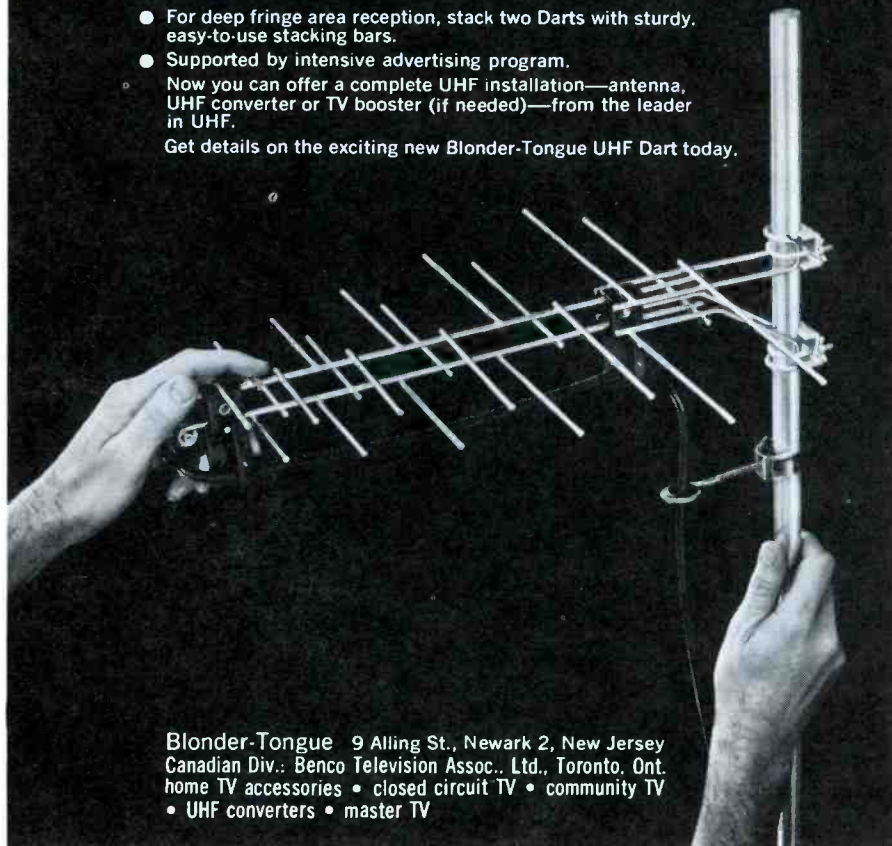

Blonder-Tongue 9 Alling St., Newark 2, New Jersey
Canadian Div.: Benco Television Assoc., Ltd., Toronto, Ont.
home TV accessories • closed circuit TV • community TV
• UHF converters • master TV

Circle 33 on literature card

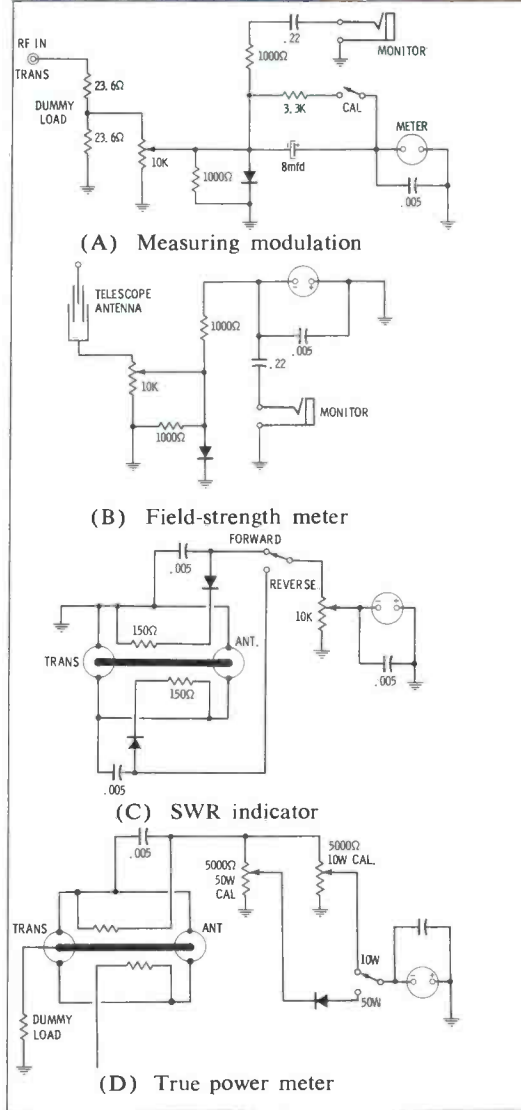

Fig. 2. Simplified schematics of functions.

ing-wave ratio of 1.1:1 (readings up to 1.5:1 are considered acceptable).

We had peaked the transmitter output tuning circuit while reading power output previously. We decided to check to see if we could get more output indication with the antenna connected. (This would have to be a relative indication, since true power could be read only into the dummy load). With the meter instrument set to read forward power, and adjusted for a midscale reading, we tried reapeaking the output plate capacitor; there was no increase in power output. We then tried reapeaking the antenna loading coil, and there was a very slight increase in meter reading—not enough to be significant.

This was of course as it should be, since the antenna was almost perfectly matched to the transmitter. And it does mean that you could peak up a transmitter in your shop, using the *Port-A-Lab*, and expect it to work well on a customer's antenna—*providing* that the customer's antenna has a low SWR and a nominal impedance near 50 ohms.

The "field strength" position of the *Port-A-Lab* was a decided asset in checking whether a transmitter was or was not working. We set it on the hood of

for every High Quality Speaker need...

LOOK IN THE NEW **JENSEN** GUIDE TO LOUDSPEAKERS



We'd like you to have a copy of our new 1090 speaker guide describing the new Concert, Viking and Weather Master Series loudspeakers. It's the largest catalog of its kind, fully illustrated with complete descriptions and easy-to-read specification tables.

Included to name only a few are: a new group of Electronic Musical Instrument speakers; a new complete range of circular and oval general purpose units; Minia-tures; special Automotive types; an augmented Viking series for inexpensive replacements; Weather Master outdoor speakers; Hi-Fi replacements; Concert Fidelity speakers and components; Intercom and Communication/Aircraft types. And there is an interesting discussion of magnetic materials.

*Write for your free copy of
CATALOG 1090 today!*



JENSEN MANUFACTURING COMPANY / DIVISION OF THE MUTER COMPANY / 6601 SOUTH LARAMIE AVENUE, CHICAGO 38, ILLINOIS
Canada: Radio Speakers of Canada, Ltd., Toronto • Argentina: Ucoa Radio, S. A., Buenos Aires • Mexico: Fapartel, S. A., Naucalpan, Mex.
Circle 34 on literature card

NEW SAMS BOOKS

Practical Transistor Theory

by E. Patrick Weisner. Up-to-date coverage of transistor devices, how they're used, and how they work. Written on a practical level for easy understanding by electronics technicians and students who have no need for high-level design theory. Explains basic principles of transistor operation; describes typical circuits and how they work; concentrates on explaining operation of modern semiconductor devices, and their application. 160 pages; 5½ x 8½". Order **PTW-1**, only **\$7.95**

ABC's of Television

by Len Buckwalter. Whether you are technically trained or not, this book will prove an invaluable reference on television. Using simplified block diagrams and down-to-earth text, it takes you through the whole process of television operations, from the studio cameras to the picture tube in the home receiver. Gives you a clear understanding of basic principles involved in TV transmission and reception (both black-and-white and color), with emphasis on how TV sets work. Chapters: Basic Principles; Creating the TV Signal; TV Antennas; What the Receiver Does; The Tuner; The IF Amplifier; Detection & Amplification; Synchronizing the Picture; The Picture Tube; How to View a Test Pattern; How Color TV Works; and other TV Systems. **\$1.95**
128 pages; 5½ x 8½". Order **ATV-1**, only.

Science Projects in Electricity/Electronics

by Edward M. Noll. This third volume in the popular *Science Projects Series* demonstrates basic principles of electricity and electronics through the construction of fascinating projects which are not only instructive but also useful. Clear text and illustrations explain modern electronics systems. Projects include transistor power amplifiers; radio-frequency amplifier; detectors and converters; wide-range oscillator; AM-FM modulators; radio remote control; light relay and industrial circuits. Ideal for self-instruction or as a science class project guide. 144 pages; **\$2.95**
5½ x 8½". Order **SPN-1**, only.

Calculus for the Electronics Technician

by Allan Lytel. Provides electronics technicians with a sound foundation in calculus, one of the basics required for a better understanding of electronics design. Includes a thorough explanation of basic differential and integral calculus, starting with the fundamental concepts of functions and variables. Examples are kept as geometrical as possible, and abstract concepts are avoided. Uses the limit process and its relation to the rate of change of a function to develop the concept of the derivative and differentiation. Clearly explains Riemann integration and discusses infinite series. Includes helpful problem sets and appendices. Anyone with a knowledge of high-school algebra can profit from this book. **\$4.95**
224 pages; 5½ x 8½". Order **CAL-1**, only.

Passive Audio Network Design

by Howard M. Tremaine. A practical ready-reference handbook for audio technicians and engineers, on the design, construction, operation and testing of passive networks. Includes sections on: Attenuator Circuits, including many basic designs and various balanced and unbalanced configurations; Equalizer Circuits, including variables, resonant circuits, recording and reproducing networks, etc.; Filter Circuit designs; Test and Measurement Techniques for checking networks. Requires only an average mathematical background for full understanding. **\$4.95**
288 pages; 5½ x 8½". Order **AHT-1**, only.

Closed Circuit TV Handbook

by Leon A. Wortman. The first comprehensive guide to closed circuit TV systems and applications. Provides complete details for the interested nontechnical reader, as well as for technical personnel who require a guide for planning, installing, operating, and maintaining CCTV systems. Describes various types of equipment available and their applications. Discusses systems for educational, commercial, and industrial uses; shows how CCTV is used in research, health and medicine, military, public utilities and services, etc. Includes chapters on installation considerations, operation and service. 320 pages; **\$7.95**
5½ x 8½", hardbound. Order **CLC-1**, only.

HOWARD W. SAMS & CO., INC.

Order from your Sams Distributor today, or mail to Howard W. Sams & Co., Inc., Dept. PF-2, 4300 W. 62nd Street, Indianapolis 6, Ind.

Send me the following books:

- PTW-1 SPN-1 AHT-1
 ATV-1 CAL-1 CLC-1

\$_____ enclosed. Send FREE Booklist

Name _____

Address _____

City _____ Zone _____ State _____

My Distributor is _____

IN CANADA: A. C. Simmonds & Sons, Ltd., Toronto 7

Circle 40 on literature card

an automobile that used a rear-bumper mounted antenna. We extended the telescoping antenna of the instrument and got a good RF reading. This is very useful as a quick check in a two-unit system.

For further information, circle 63 on literature card

Good Parts for Bad

In the field of troubleshooting, there is perhaps nothing that can give more dramatic proof of just what is causing the trouble than the substitution of a good part for one that is faulty. One of the drawbacks of this method is not having a particular component where you can find it, or having no method of conveniently making a temporary hook up.

The Mercury Model 501 *Component Substitutor* comes close to providing, at the flip of a switch, just about any common component you might want to substitute. The 501 is divided into four different sections, electrically isolated from one another, so you can use one component in one circuit and another component in some other circuit, without interaction.

One section of the unit has 24 carbon resistors in the range from 10 ohms to 5.6 megs. The lower resistance values, which normally pass more current, are 1 watt sizes; the higher values are ½ watt.

Another section has twenty 20 watt resistors, from 2.5 ohms to 15K. These can be substituted for B+, screen, or filament dropping resistors, or anywhere a high-wattage resistor is used. In temporary hookups, the resistors can be used to substitute for speaker fields or filter chokes.

Also in this second section is a substitute for either a silicon or selenium rectifier, as well as a crystal diode substitute. When substituting for a power rectifier, take care that the crystal diode is not accidentally chosen.

The third section of the 501 has 12 switch-selected bypass capacitors, from 100 mmf to 0.5 mfd, all rated at 600 volts.

The last section is for substituting electrolytics in either single or dual values. Electrolytics in pairs from 4 to 80 mfd in one range and 8 to 150 mfd in another range can be substituted simultaneously. By paralleling the two ranges (A and B) you can substitute for a single capacitor from 12 to 230 mfd.

An added feature of this electrolytic section is the "surge protector" switch. When this switch is "on," a 500 ohm resistor is placed in series with the substitute electrolytics. This prevents a sudden surge of charging current into the substitute capacitor (which often causes temporary healing of a defective capacitor making *sure* diagnosis difficult). After the substitute capacitor has been connected to the circuit, the switch is returned to the "Normal Subst" position, and the substitute capacitor is connected directly into the circuit.

The attractive gray and black case of the 501 measures 10"W x 6"H x 4"D. A 1¼" high compartment across the bottom is used for lead storage. Two

The customer may think the receiver in one unit is defective when it is really the transmitter of the other unit. Checking the RF output and modulation keeps you from being misled.

sets of leads come with the instrument.

We put the 501 on the lab bench and waited for an appropriate service problem to come along. The first was a set that had insufficient height. We suspected that either the height control was open or the 1 meg series resistor had changed value. We connected test leads to the carbon resistor section of the 501, set the selector switch for 1 meg (1K with slide switch to R x 1000). We clipped the leads across the height control and there was no change in raster height, indicating that the height control was likely okay. We removed the leads from the height control and connected them across the 1 meg series resistor; the raster filled out and had considerable overscan and stretch at the bottom. Adjusting the height control gave us a linear picture and proved beyond doubt that the 1 meg resistor was virtually open.

The next set was one with insufficient width. This set had a voltage doubler power supply. This meant that either a selenium rectifier or perhaps one of the electrolytics *could* be faulty. Substituting for both seleniums, one at a time, had little or no effect on the raster. We moved the leads on the 501 to the electrolytic substitution section, set the dial for 150 mfd, placed the slide switch on the "surge protect" and connected the clip leads across the AC input electrolytic in the TV set. We moved the slide switch to "Normal Subst" and the raster widened completely—indicating, of course, a partially open input electrolytic.

The third set had a bend and weave picture and also a slightly narrow raster. We used the 501 to substitute a 50 mfd capacitor across the B+ line to ground; this cured most of the bending. Another electrolytic (20 mfd) substituted across the horizontal oscillator decoupling resistor straightened up the picture completely. The raster, however, was still slightly narrow.

In checking over the set we found that someone else had apparently changed the



Fig. 3. Unit contains four separate sections.

Can you afford to guess

AT SWEEP, SYNC OR HIGH VOLTAGE TROUBLES?

WHEN IT'S SO EASY TO WALK THE TROUBLE
RIGHT OUT OF THESE TIME CONSUMING
CIRCUITS..... STEP BY STEP.....



SYNC. CIR.
& H. SYNC.
DISCRIM.

VERT.
OSC.

VERT.
OUTPUT

VERT.
OUTPUT
XFORMER

VERT.
DEFLEC.
YOKE

HORIZ.
OSC.

HORIZ.
OUTPUT

HORIZ.
FLYBACK
XFORMER

2nd ANODE
VOLTAGE
CIRCUIT

HORIZ.
DEFLEC.
YOKE

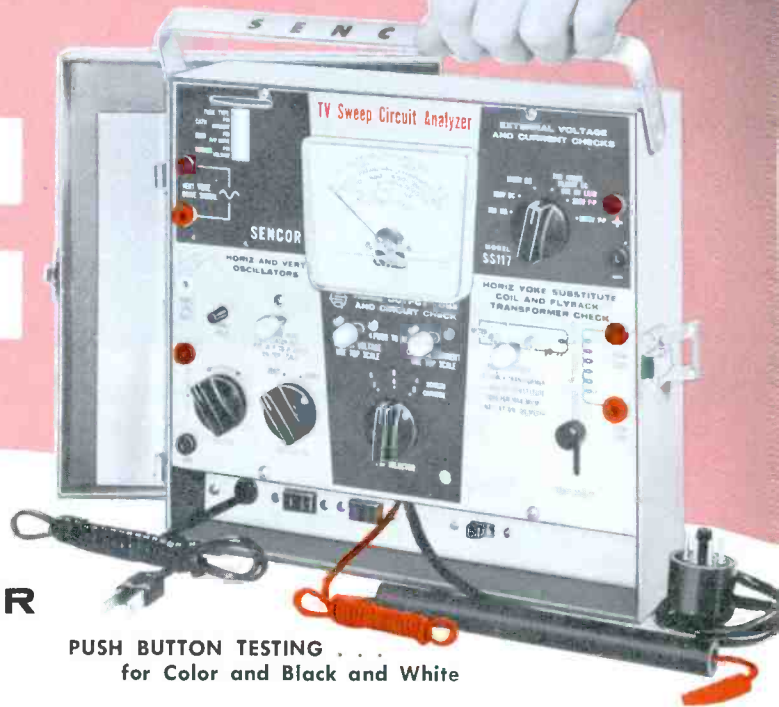

NEW, IMPROVED SENCORE SWEEP CIRCUIT ANALYZER MODEL SS117

PUSH BUTTON TESTING . . .
for Color and Black and White

How many times do you ask, "Why do I take so long finding that sweep trouble?" How often have you wondered whether weak horizontal sync was caused by defective sync circuit, horizontal oscillator, or sync discriminator? Can you quickly isolate inadequate width or low 2nd anode voltage to the oscillator, output, flyback transformer, or yoke? How many times have you changed a good yoke by mistake?

The SS117 will pinpoint troubles like these in minutes with tried and proven signal injection, plus yoke substitution for dynamic in-circuit tests. Error proof push button testing enables you to make all tests from the top of the chassis without removal from cabinet for maximum speed and profit on every job.

Here are the checks the SS117 makes . . .

- Horizontal Oscillator: Checked by substituting 15,750 variable output universal oscillator from SS117. Signal can be injected at any spot from horizontal output grid to horizontal oscillator to determine defective component.
- Horizontal Output Stage: Checked by reliable cathode current and screen voltage checks made with adapter socket and two push buttons.
- Horizontal Output Transformer: Checked for power transfer in circuit and read as good or bad on meter.
- Horizontal Deflection Yoke: Checked by direct substitution with adjustable universal yoke on SS117.

- Vertical Oscillator: Checked by substituting 60 cycle synchronized oscillator.
- Vertical Output Transformer: By simple signal injection for full height on picture tube.
- Vertical Deflection Yoke: By signal substitution for full height on picture tube.
- Sync Stages: Checked by synchronizing triggered horizontal SS117 oscillator from any stage. If oscillator synchronizes, sync is O.K.
- 2nd Anode Voltage: A new dynamic check using simulated picture tube load. C.R.T. does not need to be operating for current tests. No interpretations—read direct from 0 to 30 KV.
- External Circuit Measurements: By applying from 0 to 1000 volts AC or DC to external meter jacks. Meter will read DC or peak-to-peak volts. 0 to 300 milliamp scale also provided for measuring horizontal fuse current.
- New features include: Large 0 to 300 microamp meter for minimum circuit loading; all-steel carrying case with full mirror in adjustable cover; two 115 volt AC outlets in cable compartment.

Size: 10 1/4" x 9 1/4" x 3 1/2". Wt. 10 lbs.

Model SS117

Dealer Net **\$89⁵⁰**



Sencore Sam says . . . How can you miss . . .

EACH PACKAGED UNIT CONTAINS:

- An Easy to Follow Instruction Book Especially Prepared and Edited by H. W. Sams.
- A complete 33 RPM, 10 inch Permanent Record on "How to Simplify Sweep Circuit Trouble Shooting."

SEE YOUR AUTHORIZED SENCORE DISTRIBUTOR
Circle 36 on literature card

SENCORE
ADDISON, ILLINOIS

Coming in the March TEST EQUIPMENT issue

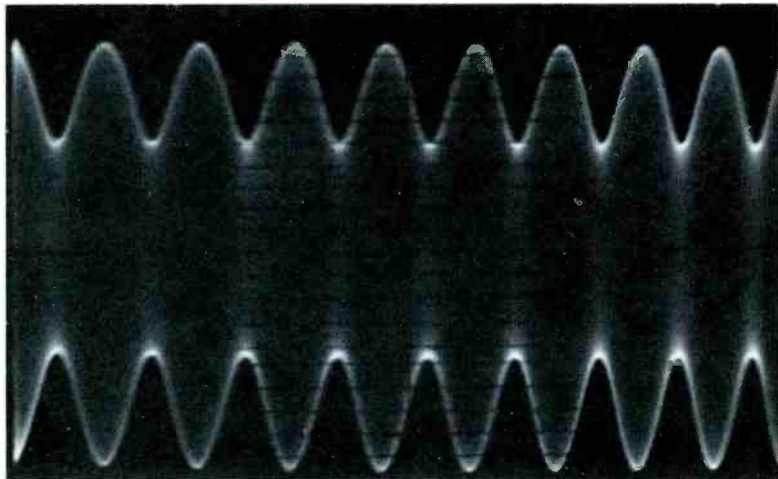

Curing Troubles in AM-FM Generators

Keep instruments in tip-top shape.

Servicing TV with VOM or VTVM

It can be done. Here's how.

Instruments Solve Color "Tough Dogs"

Case histories that prove the point.

Good Test Equipment Doesn't Cost . . . It Pays

Here's how to get your money's worth.

Aligning TV With A Signal Generator

Solve RF-IF problems this easy way.

Plus these Extras . . .

- Troubleshooter
- Video Speed Servicing
- Previews of New Sets
- Notes on Test Equipment

Get Free Premium Books With Subscription

Enter my subscription to PF REPORTER
and send me free book(s) checked.

3 Years \$10.00 2 Years \$8.00 1 Year \$5.00

- The Troubleshooter's Handbook No. 2
- Servicing Industrial Electronics
- Servicing TV from Tuner to Picture Tube

Check one for
each year you
subscribe

Bill Me Remittance Enclosed

Extend Present Subscription

Take this coupon to your distributor, or mail to:

Howard W. Sams & Co., Inc.

4300 W. 62nd St., Indianapolis, Ind. 46206

Name _____

Firm _____

Address _____

City _____ Zone _____ State _____

Please Check Your
Business Classification

- Independent Radio, TV Serviceman
- Retailer with Service Department
- Industrial Electronics Service
- Other (Specify occupation and title) _____
- Owner, Mgr.
- Service Mgr.
- Employee



Fig. 4. Instrument substitutes for almost any part encountered in most electronic equipment.

6BQ6 horizontal amplifier, but had failed to check the screen resistor which often burns and changes value when a tube goes bad. We measured the voltage at the 6BQ6 screen and found it was only 110 volts. This seemed slightly low, so we substituted a 15K, 20 watt resistor from the 501 across the discolored screen resistor. Immediately we had more than ample raster width.

To find the size that would work the best, we clipped out the original resistor and kept switching in lower values of resistance until we got sufficient raster width with about $\frac{3}{4}$ " overscan. This happened to be a 7500 ohm resistor as indicated by the 501; we actually replaced it with an 8200 ohm unit.

The above three case histories cite just a few of the uses for a substituter. It can be used to check linearity controls, height controls, vertical and horizontal hold controls, and other variable controls—at least to indicate roughly if there is trouble in these parts—by substituting various fixed values of resistance in their place. Experimental circuit changes can be quickly set up and checked out. Unknown values of resistance and capacitance can be approximated. The entire cost of a substituter is less than the individual parts would generally cost if purchased singly, and the added convenience can't help but speed up any service operation. ▲

For further information, circle 64 on literature card

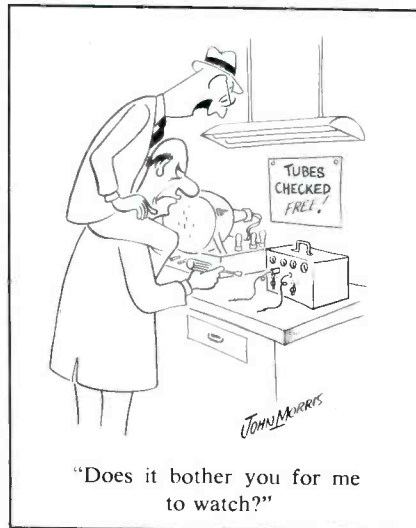

CTC 15 Color TV Chassis gives brighter, sharper picture; has greater reliability; is easier to service... than any previous RCA Victor Color TV Chassis!

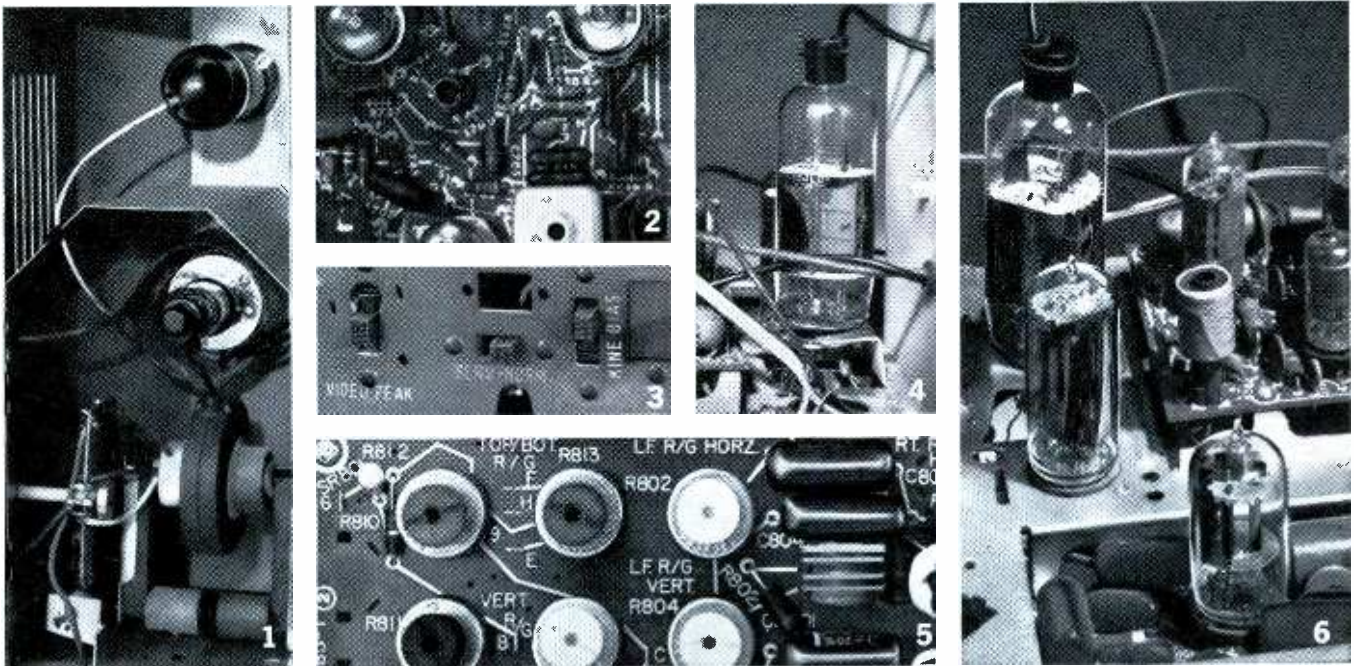

RCA Victor's new CTC 15 chassis keeps all the performance-proved virtues of the CTC 12 . . . but adds these engineering improvements that should please both you and your customers:

The picture is brighter, better. It's brighter because a new design in the high voltage section (1) gives 30% more current output at the same voltage. The picture tube circuits are designed for effective use of this higher power.

It's sharper because the picture tube screen voltages have been boosted . . . giving a smaller, sharper dot pattern with less blooming. The video amplifier has better phase response.

It's steadier because of substantially improved vertical hold circuits.

A new picture "tone control" . . . it's a video peaking switch (3) . . . offers three choices of picture quality: soft, normal and sharp. When snow and ghosts are your problem, use the soft setting for a smoother, more pleasing picture. When the signal is better, make the most of it with the normal or sharp setting.

Less color fringing results from a new clamp diode in the convergence circuit and rearranged controls are easier to use.

And UHF reception is improved by new circuitry that reduces snivets . . . those black vertical lines near the center of the picture.

Greater reliability . . . longer component life. Heat build-up has been reduced by housing the flyback transformer and the regulator tube in separate compartments.

The horizontal output tube (4) is placed on a raised "cooling shelf" outside the H.V. compartment. Its position allows free flow of air around its base. Three conventional tubes have been replaced by novars (6). They run cooler and last longer. One of them is the hardest working tube in the set—the horizontal output tube.

And dark heater tubes are used in all high-performance circuits.

To further increase life, the focus rectifier is now a special long-life selenium type.

Easier servicing. Circuit tracing is easier and faster . . . the new schematic solid-line roadmaps (2) go point-to-point, and component labels are larger.

It's easier to service the high voltage

compartment . . . it has a hinged cover and better arrangement.

Color setup has been simplified by the addition of a conveniently placed 3-position bias switch (3) which accommodates wide variations of picture-tube characteristics.

RG controls (5) on the convergence board have also been rearranged for your convenience. Now you use the entire top row to make adjustments according to the horizontal lines in a crosshatch pattern; the entire second row is for the vertical lines.

Color TV is the technician's big bread and butter business . . . for years to come. We stand ready to help in every possible way to make this fast-growing business a profitable one for technicians—and for dealers as well.

See Walt Disney's "Wonderful World of Color," Sundays, NBC-TV Network.



The Most Trusted Name
in Television

Tmk(s)®

Synchroguide

(Continued from page 33)

example, an oscillator-frequency core turned all the way in is a clue to a higher than normal resonant frequency of the oscillator. Decreased value of some component in the oscillator circuit is a possibility, but it's more likely that the grid voltage on the control tube is not negative enough. Leakage in C1, C2, C7, or possibly C8 (Fig. 1) can cause this condition. Sometimes the leakage develops slowly as the temperature of the set rises during

operation; if so, the oscillator will seem to be drifting. When C4, C5, or C6 becomes leaky, the chief symptom is usually that the adjustment of the hold control becomes critical.

The quality and amplitude of the sync pulses are instrumental in obtaining good sync and adequate hold-control range. Low amplitude of the sync signal will make the oscillator tend to fall out of sync on the low-frequency side, producing a symptom like Fig. 4A. Video or hum contamination in the sync signal will cause portions of the

CAN THIS PICTURE TUBE BE SAVED?

Fading dull picture tubes bounce back pronto with Perma-Power Briteners

Give new life, new brightness to aging picture tubes—and watch your customer's confidence in you bounce back, too, when you sell a \$4.00 britener instead of a \$70.00 tube. (Then you're a cinch for the tube sale later.)

It's easy with Perma-Power's **Tu-Brite**. Handsomely packaged for instant acceptance, color-coded by base type for instant selection. The right voltage is assured. With Tu-Brite, *if the base is right, the boost is right*. Make sure you have all three models in stock.

Model C-202 for duodecal base CRT's.

Model C-212 for 110° button base CRT's.

Model C-222 for 110° shell base CRT's. Net \$2.25 each.

Write for free **Britener Selector Chart**, your guide to the base type of every picture tube now in the field.

YES! Perma-Power Brightens Color Sets, Too. **Color-Brite Model C-501**, Net \$5.85 each.



Perma-Power COMPANY

5740 North Tripp Avenue • Chicago, Illinois 60646

Phone: 539-7171 (Area Code 312)

Circle 38 on literature card



(A) Oscillator frequency low



(B) AFC too critical



(C) Oscillator frequency high



(D) Oscillator out of phase

Fig. 4. Visual symptoms are a useful tool for analyzing trouble in *Synchroguide* circuit.

picture to pull to the left, and any interruption of the sync signal—a station break, a camera change, or switching to a different channel—may cause the picture to fall entirely out of sync with bars sloping down to the right (Fig. 4C).

The technique of servicing by symptom analysis is probably applied more often to the *Synchroguide* than to any other TV circuit. It doesn't matter whether the serviceman calls it "symptom analysis" or "servicing by hunch"; it still leads to a lot of hunches that pay off.

Stage Isolation

The most obstinate troubles, which don't yield to any other servicing procedure, can be cracked by separating the AFC and oscillator circuits. This approach seeks to determine whether or not the oscil-

STEREO



Let **RCA** equip you with **EVERYTHING YOU NEED FOR STEREO SERVICING**

RCA—entertainment leader of the world—now offers you a complete set of test instruments to put you in the stereo servicing business. And now's the time to get in because it's growing bigger and more profitable by the day.

A. NEW! RCA WR-51A FM STEREO SIGNAL SIMULATOR

Generates signals necessary to service and maintain stereo multiplex FM receivers and adaptors. Generates... Choice of 4 FM signals—Left Stereo, Right Stereo, Special Phase Test, Monaural FM • Choice of 8 sine-wave frequencies (400 cps, 1Kc, 5Kc, 19Kc, 28Kc, 38Kc, 48Kc, 67Kc) available separately or for modulating FM signals • 100 Mc carrier tuneable ± 0.8 Mc to permit selection of a quiet point in the FM band • 19 Kc subcarrier, crystal-controlled within ± 2 cps • 100 Mc sweep signal adjustable from 0-750 Kc at 60 cps rate • Choice of 3 composite stereo output signals—Left Stereo, Right Stereo, Special Phase Test • Choice of 3 sine-wave frequencies for composite stereo

signals • Crystal controlled markers for receiver if and if alignment • Zero-center meter for checking the balance of stereo amplifier output. **\$249.50***

B. RCA WA-44C AUDIO GENERATOR

Generates sine-wave and square-wave signals over range of 20 to 200,000 cps to test audio systems. Can be used to measure intermodulation distortion, frequency response, input and output impedance, speaker resonance, transient response and phase shifts. Less than 0.25% total harmonic distortion over range of 30 to 15,000 cps. **\$98.50***

C. RCA WO-91A 5" OSCILLOSCOPE

A high-performance, wide-band 'scope—serves as a visual VTVM. Choice of wide band (4.5 Mc–0.053-volt rms/inch sensitivity)

or narrow, high-sensitivity band (1.5 Mc–0.018-volt rms/inch sensitivity). New 2-stage sync separator provides solid lock-in on composite TV signals. **\$249.50***

D. RCA WV-98C SENIOR VOLTOHMYST®

For direct reading of peak-to-peak voltages of complex waveforms, rms values of sine-waves, DC voltages, and resistance. Accuracy: 3% full-scale on both AC and DC, with less than 1% tracking error. Color-coded scales differentiate peak-to-peak from rms readings. New 0.5 volt full scale DC range for use with low-voltage transistor circuits. $6\frac{1}{2}$ " meter. **\$79.50***

E. RCA WV-76A AC VTVM

Measures voltages down to 0.001 volt. Decibel scale for measure-

ments from -40 to +40 db. Built-in amplifier which may be used separately as a preamplifier. Typical applications include: frequency response tests of preamplifiers, power amplifiers and tone control circuits, signal tracing; measurements of audio level, power level and gain; amplifier balancing applications and general audio voltage measurements. **\$79.95***

F. RCA WG-360A STEREO PHASE CHECKER

A quick, simple, positive way to check phase alignment of low and mid-range speakers in stereo systems. Completely "sound-powered". Snag-proof recessed grille design. For use with a VOM, VTVM, or oscilloscope. **\$14.95***

See Them all at your Authorized RCA Electronic Instrument Distributor
RCA Electronic Components & Devices, Harrison, N. J.

*User price (optional)



The Most Trusted Name in Electronics

Circle 39 on literature card

**YOU NAME IT—
ATLAS SOUND
HAS IT!**



You profit more by using the same dependable brand of public address speakers and microphone stands for all your needs.

Your ATLAS SOUND distributor makes one-stop shopping easy with a wide selection of proven models...backed by our years of commercial sound experience...concern for product reliability...pricing for your profit.

Look for the ATLAS SOUND mark of quality on all paging and talkback speakers, trumpets, drivers, explosion-proof speakers, sound columns... floor, desk, boom stands... accessories for all. This trademark makes a world of difference. Write for catalog PF-2



ATLAS SOUND, Division of
AMERICAN TRADING AND PRODUCTION CORPORATION
1419-51 39th Street, Brooklyn, New York 11218
Canada: Atlas Radio Corporation, Toronto



THIRTY YEARS OF LEADERSHIP IN COMMERCIAL SOUND
Circle 40 on literature card

**Save Time
on PC Board
Repairs!**



Melted solder disappears up hollow tip into tube

The ENDECO Desoldering Iron Removes Soldered Components in seconds...without damage!

Endeco melts solder, then removes it by vacuum • Leaves terminals and mounting holes clean • Resolders too • One-hand operation • Temperature controlled for continuous use • Ideal for use with shrinkable tubing • 4 tip sizes • Quickly pays for itself in time saved • Only \$18.75 net.

SEE YOUR DISTRIBUTOR OR WRITE



**ENTERPRISE
DEVELOPMENT
CORPORATION**

1102 E. 52ND • INDIANAPOLIS, IND. 46205

Circle 41 on literature card

64 PF REPORTER/February, 1964

3 WAYS TO BIGGER



NEEDLE



CARTRIDGE PROFITS!

1. More "look-alike" exact replacement models than any other brand. Over 350 needles, 225 cartridges. 2. Easy-to-use reference material. E-V computer-printed catalogs make proper needle/cartridge selection easy, fast and accurate. 3. Highest standards. Rigid quality control and inspection cuts call-backs, gives full value to every customer. *Stock and sell E-V needles and cartridges for more profits, today! Write for FREE replacement guides!*

ELECTRO-VOICE, INC., Dept. 247R Buchanan, Michigan

Electro-Voice
SETTING NEW STANDARDS IN SOUND

Circle 42 on literature card



Fig. 5. Grid waveform of AFC stage corresponding to visual symptom shown in Fig. 4D.

lator can run at or near the correct frequency without being influenced by the AFC. In a few cases, the AFC can be disabled by grounding its cathode, but this procedure is not reliable; in many models, it will force the oscillator far off frequency. Better results can be obtained by actually disconnecting the two sections of the circuit.

The dashed lines in Fig. 1 mark the division between the oscillator and control sections. Double lines are used to emphasize the fact that R3 is common to both stages—being included in the cathode return of the AFC stage and the grid return of the oscillator. Breaking the connection at the left dashed line will allow the oscillator to operate by itself. Removal of the positive AFC voltage will cause the oscillator to slow down; thus, the CRT will normally present a pattern of bars slanting downward to the left. By backing the core out of the frequency coil, it should be possible to make the oscillator run at 15,750 cps and maintain this approximate frequency.

Isolating the oscillator helped me solve one puzzling case many years ago, and the experience gained at that time has repeatedly been useful in handling later cases. In the original trouble, the oscillator frequency was much too high, even after I disconnected R2 and R4 from R3. I'd previously substituted all frequency-determining components, and had nullified the effect of the ringing coil by clipping a jumper across it. Almost ready to conclude that the frequency coil had some shorted turns, I glanced once more at the schematic and noticed something I had not seen before: The sawtooth-



Fig. 6. Presentation in Fig. 4D is changed to this if waveform coil is shunted with jumper.

BEST PROFESSIONAL VTVM VALUE

EICO 232 peak-to-peak VTVM featuring exclusive Uni-probe® (U.S. Pat.)



Deluxe VTVM for color & B & W

Never before such an outstanding instrument at such a low price! Calibration without removing from cabinet. Measure directly p-p voltage of complex & sine waves: 0-4, 14, 42, 140, 420, 1400, 4200. DC/RMS sine volts; 0-1.5, 5, 15, 50, 150, 500, 1500 (up to 30,000 volts with HVP probe, & 250 mc with PRF probe). Ohms: 0.2 ohms to 1000 megs. 4 1/2" meter, can't-burn-out circuit. 7 non-skip ranges on every function. Zero center. Features EICO's exclusive UNI-PROBE: A terrific timesaver, performs all functions: A half turn of probe-tip selects DC or AC-Ohms! Kit \$29.95; wired \$49.95.

EICO KITS FOR 1964

BEST BUY SCOPES

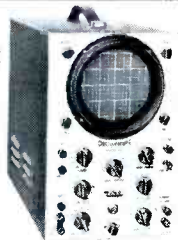

EICO 460 WIDEBAND 5" SCOPE For color & black-and-white TV servicing. Easily reproduces 3.58 mc color TV synchronizing burst. Vert. amp. flat from DC to 4.5 mc, usable to 10 mc; 25 mv rms/inch sensitivity. Horiz. amp. flat from 1 cps to 400 kc; 0.6 v rms/inch sensitivity. Automatic sync. Sweeps from below 10 cps to 100 kc. Kit \$89.95; Wired \$129.50.



EICO 427 ADVANCED GENERAL PURPOSE 5" SCOPE High sensitivity scope has all the facilities and quality demanded for servicing audio, communications and industrial equipment. Vert. amp. flat from DC to 500 kc, -6 db at 1 mc; 3.5 mv rms/cm sensitivity. Horiz. amp. flat from 2 cps to 450 kc; 0.18 v rms/cm sensitivity. Automatic sync. Sweeps from 10 cps to 100 kc. Kit \$69.95; Wired \$109.95.



EICO 430 PORTABLE GENERAL PURPOSE 3" SCOPE Remarkably fine compact scope. Excellent for servicing audio, communications, and industrial equipment. Ideal as a ham shack monitor. Flat-face 3" CRT with mu metal shield eliminates affects of external fields. Vert. amp. flat from 2 cps to 500 kc, -6 db at 1 mc; 25 mv rms/cm sensitivity. Horiz. amp. from 2 cps to 350 kc, 0.25 v rms/cm sensitivity. Sweeps from 10 cps to 100 kc. Kit \$65.95; Wired \$99.95.



EICO 955 IN-CIRCUIT BRIDGE-TYPE CAPACITOR TESTER Unique shunt-resistance balancing* provision, permits in-circuit short checks even in the presence of as little as 1 ohm shunt resistance. Sensitive open check down to 15 μmf normally, adjustable to as little as 5 μmf. Wien Bridge capacity measurements from 0.1 to 50 μf. Kit \$19.95; wired \$39.95 *Pat. applied for.



EICO 667 DYNAMIC CONDUCTANCE TUBE & TRANSISTOR TESTER Combines mutual conductance test with a peak emission test—gives a single reading of tube quality. Also spots bad NPN and PNP transistors by gain and leakage tests. New 1964 design has sockets and settings for the latest receiving types, including 5 and 7-pin novators. Also tests novars, 10-pin miniatures, and compactrons, many low-power transmitting and special-purpose tubes, voltage regulators, electron-ray indicators, etc. Multi-circuit lever switch; 13 tube-element pushbutton switches. 4 1/2" meter; roll-chart in snap-in window. Kit \$79.95; wired \$129.95. **EICO CRU CRT ADAPTER**—Adapts 667 to test all color and B & W CRT's. Wired \$9.95.



FOR COLOR AND B & W

EICO 369 TV/FM SWEEP GENERATOR WITH BUILT-IN POST INJECTION MARKER Feeds only the sweep signal to the circuit under test or alignment. A demodulator picks off the response signal and feeds it to a mixer stage where the markers are added before scope display. Thus, troublesome interaction effects are eliminated. Sweep generator has controllable inductor sweep circuit (all electronic) with no mechanical parts to wear and give trouble, and 5 fundamental ranges from 3.5 to 316 mc. Variable frequency marker provides output on 3 fundamental ranges from 2 to 60 mc., and 60 to 225 mc range on harmonics. 4.5 mc crystal supplied for rapid check of marker generator alignment. Kit \$89.95; wired \$139.95.

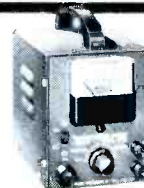

TOP-NOTCH TRANSISTOR TESTING TEAM
EICO 1020 POWER & BIAS SUPPLY with 0.005% ripple. Continuously variable metered output voltage, 0-30 VDC at 150 to 300mA. Kit \$23.95; wired \$29.95.



EICO 680 TRANSISTOR & CIRCUIT TESTER Measures basic characteristics of signal and power transistors. Provides DC current, DC voltage (20K ohm/volt), and resistance ranges normally needed for transistor work. Kit \$25.95; wired \$39.95.

EICO Electronic Instrument Co., Inc. PF-2
131-01 39th Avenue, Flushing, N.Y. 11352

Send new 1964 catalog featuring more than 230 EICO Products.

NAME _____

ADDRESS _____

CITY _____ ZONE _____ STATE _____

Add 5% in West

SERVICE MASTER... EVERY TOOL YOU NEED 99% OF THE TIME



complete 23-piece kit for radio, TV,
and electronic service calls

2 HANDLES:

shockproof plastic. Regular 4" length... 2" Stubby. Interchangeable. Patented spring holds snap-in tools firmly in place.

9 NUTDRIVERS:

High Nickel chrome finish, 3/8" to 1/2"

3 STUBBY NUTDRIVERS:

1/4", 3/8", 3/8"

EXTENSION BLADE:

Adds 7". Fits both handles.

3 SCREWDRIVERS:

Two slotted... 3/16", 3/32" #1 Phillips

2 REAMERS:

1/8-3/8", 1/4-1/2"

ADJUSTABLE WRENCH:

6" thin pattern, 1" opening

LONG NOSE PLIER:

"Cushion Grip", 2 1/4" nose

DIAGONAL PLIER:

"Cushion Grip" hand-honed cutting edges

ROLL UP KIT:

Durable, plastic-coated canvas. Compact, easy-to-carry.

Ask your distributor to show you kit 99 SM



XCELITE, INC., 18 Bank St., Orchard Park, N.Y.
Canada: Charles W. Pointon, Ltd., Toronto, Ont.

Circle 44 on literature card

66 PF REPORTER/February, 1964

forming capacitor did not return to ground, as does C12 in Fig. 1; instead, it connected to the cathode of the horizontal output tube. The ground return for this point was via a 100 ohm resistor, bypassed by a .47 capacitor. Shunting a new .47 across these components made a considerable change in the raster. Many bars sloping to the right gave way to a smaller number of bars sloping to the left—a normal indication, considering that the B1 slug had previously been set as far into the coil as possible. Correct operation was restored by replacing the .47, reconnecting the AFC, and realigning the *Synchroguide*.

Unlike the oscillator, the AFC stage cannot be made to operate normally by itself. With the connection between R3 and R5 broken at the right-hand dashed line, one might expect the voltages on the AFC tube to be close to normal; but such is not the case. Whereas the normal cathode voltage in most circuits is within plus or minus 20 volts of zero, it rises to a much higher value (on the order of 100 volts) when the stage is isolated. This change reveals the necessity of applying negative voltage from the oscillator grid to the control-tube grid for correct biasing of the AFC stage.

In summary, the grid-cathode circuit of a *Synchroguide* system is a two-way street that supports a complex interaction between the AFC and oscillator stages. This potential source of confusion makes it imperative to use extra care in analyzing all aspects of a service problem. ▲



"People think us TV servicemen have it soft! Why, I've already been to two homes today where they didn't even offer me coffee or cake."

CORRECT OFF-STANDARD VOLTAGE WITH



Acme Electric

VOLTAGE ADJUSTORS

You can't get the best performance from a TV set or other electronic equipment unless it's operating on proper voltage. The Acme Electric T-8394M Voltage Adjustor corrects voltage over a range of 95 to 125 volts to normal 115/120 volts, simply by turning a regulating switch. Have a T-8394M Voltage Adjustor with you on every service call. You can use it for testing the line—and sell it on more jobs than you realize. A full 300 watts. Compact. Inexpensive. Most good supply dealers stock them. For full information write for Bulletin 161. SAA 3673-3027

ACME ELECTRIC CORPORATION

942 WATER ST. • CUBA, N. Y.

In Canada: Acme Electric Corp. Ltd., 50 Northline Rd., Toronto, Ont.

Circle 45 on literature card

New BERNS Perfect Pin Crimper

Picture-Tube Repair Tool

Also for—5U4, 6SN7, 6BQ6, etc.

Eliminates that hard soldering job

only \$1.25 each

Also for color pic tubes



Patented

Fix loose pin connections in seconds. Pays for itself in time saved on first job. 3" long.

Intermittent operation of picture tubes and other tubes due to defective solder connections easily corrected. Provides solid electrical connections, can also be used as channel-selector wrench and screwdriver. Pin keeps its original form. A 3-in-1 tool.

3 MODELS ELIMINATE SOLDERING

Makes Solid Electrical Connections
Phono Pin-Plug Crimper

Slip wire in "pin plug," insert in tool, and squeeze job is done.

C-rings 1c ea. Use end of tool to push on C-ring for ground connection.



Ant. plugs, hi-fi, multiple plugs, public address, radio and TV tubes, radar, speakers, and loop connections. Many, many more uses.

Model LC-3 for 5/32\"/>

At your parts distributor or write us

BERNS

Mfg. Co.
9853 Chalmers,
Detroit 13, Mich.

Circle 46 on literature card



"It's a lifesaver."

We didn't say it. A lot of technicians have used these very words to describe PHOTOFACT. One particular letter (unsolicited) says it like this:

"I wouldn't think of being in business without PHOTOFACT. It's a lifesaver."

Others say they're sunk without PHOTOFACT. We don't really expect anyone to "drown" without it, but we do know it saves time and saves trouble and floundering around. We do

know it often means all the difference between making a profit and not.

There are over 40 "lifesaving" features in every PHOTOFACT Folder, time-saving features to show you the way to *fast* TV-radio troubleshooting. (Really keeps you on top of those tough-dog jobs.)

Users don't measure PHOTOFACT by its pennies-per-page cost. It's the time-saving, profit-making worth of

PHOTOFACT that counts.

Of course, you can get along without PHOTOFACT—a few do—and maybe they're making a living. But it's the hard way.

Doesn't it make good sense to see your Sams Distributor today for details on an Easy-Buy PHOTOFACT Library and Standing Order Subscription?

Or use the coupon below.

A PHOTOFACT LIBRARY PAYS ITS OWN WAY—

Now, more than ever, it pays to own PHOTOFACT—the world's finest TV-radio service data. Now, you can start or complete your PHOTOFACT Library this Easy-Buy Way:

- **FREE** with your order for 180 Sets—a deluxe 4-drawer file cabinet worth \$38.95 • **Only \$10 down** • 30 months to pay • **No interest or carrying charges** • **Prepaid transportation** • **Add-on privilege of a year's advance subscription to current PHOTOFACT on the same Easy-Buy contract** • **Save 30¢ per Set—special \$1.95 price applies on Easy-Buy (instead of the regular \$2.25 price).**

4 Ways to Select Your PHOTOFACT Library: 1. Complete your present PHOTOFACT Library. 2. Order a PHOTOFACT "Starter" Library—180 Sets (Sets 301 to 480—coverage from 1955 to 1960—only \$11.36 per month). 3. Order by brand name and year—see the handy selection chart at your Distributor. 4. Order a complete PHOTOFACT Library—get **FREE** file cabinets, *plus* a selection of invaluable books and Electronics Courses.

SEE YOUR SAMS DISTRIBUTOR FOR FULL DETAILS, OR MAIL COUPON ▲
Circle 47 on literature card

Howard W. Sams & Co., Inc., Dept. PFF-2
4300 W. 62nd St., Indianapolis 6, Indiana

Send **FREE Photofact Cumulative Index** 

Send full information on Easy-Buy Plan

Enter my Photofact Standing Order Subscription

My Distributor is _____

Shop Name _____

Attn. _____

Address _____

City _____ Zone _____ State _____

Service Procedures TIS

(Continued from page 31)

Be certain the coil develops a high voltage spark for each pulse of the switcher. Lastly, be sure the distributor cap and rotor are transferring the spark to the plugs. If you check the steps in the order given, you'll quickly isolate the faulty section.

The Transistorized Switcher

Having verified that the switcher is faulty, you'll then have to service it. The units that appear on cars as original equipment will almost in-

variably be serviced only by authorized service stations; if you are one of these, the manufacturer will undoubtedly furnish you with servicing information.

Most present systems are kits or sets of components installed on automobiles that already had conventional systems. It is these "kit" and "component" systems the average service technician will be asked to service, so we will discuss the major types included in this group.

Single Transistor

In the conventional system, the breaker points must carry the 10

amp surge needed to pulse the coil effectively. In the transistorized system, a transistor must be capable of carrying this heavy load, instead of the points.

Fig. 4 shows a common circuit using only one transistor. The emitter-collector circuit of the PNP transistor is in series with the primary of the coil, as shown in the small inset box in the corner. When the breaker points are closed, R1 and R2 form a divider and set the bias for the transistor base. Their values forward bias the transistor into full conduction (saturation), thus setting up flux lines in the coil primary. When the points open, the effect of R2 is removed, and R1 simply connects the base to the same voltage as the emitter. The transistor is thus suddenly biased to cutoff, and current through the transistor and ignition coil is halted. The collapse of flux lines in the coil causes a high voltage pulse in the secondary; the pulse is transferred by the distributor to the proper spark plug.

The counter-emf generated under such rapid change is just as strong in the transistorized system as in the conventional coil, but the counter-emf affects the transistor instead of the points. To prevent these high transient voltages from damaging the transistor by exceeding its reverse ratings, zener diode M2 conducts them away from the transistor. Isolating diode M1 keeps these wrong-polarity pulses out of the power supply; therefore they are dissipated in resistor R3. C1 overcomes any tendency of the zener diode to create transients of its own.

Fig. 5 shows a circuit that operates the same, but is even simpler than the one in Fig. 4. A special

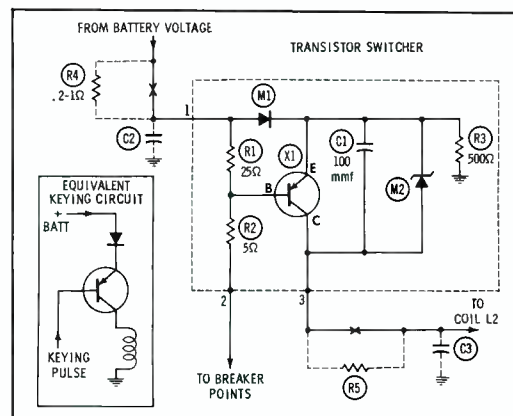

Fig. 4. This single-transistor circuit is used in a number of modern ignition systems.

Circle 48 on literature card

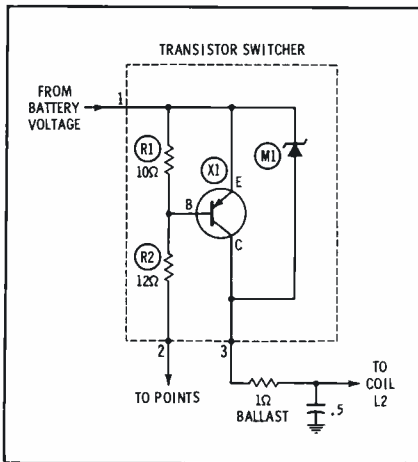

Fig. 5. Special PNIP transistor permits a much more simplified single-transistor unit. type of transistor is used—the PNIP transistor, one in which a layer of almost pure germanium between the collector and base increases the breakdown rating. Using the PNIP unit, a switcher can be built that needs only one zener diode for protection.

In Figs. 4 and 5 are some capacitor and resistor networks at terminals 1 and 3. They suppress even further any transients that may cause noise in the car's electrical system, often affecting radio reception. Some systems include them; others do not. Whether they are inside or outside the switcher, they must be considered in troubleshooting.

Two Of A Kind

Systems that use two transistors generally operate the same as the switchers just outlined, except that *two* transistors are in series with the coil primary. Fig. 6 shows a popular two-transistor circuit.

Forward bias for X1 is set by R2 and R3, when the points are closed; bias for X2 is developed by R4 and R5, since X1 is already conducting at saturation. M1 has no effect on forward bias of the transistors, since it, too, is forward biased and saturated.

When the points open, bias is removed, and X1 is cut off. Since this prevents further conduction, the base of X2 assumes the same potential as its emitter, and X2 is also cut off. The instant X1 stops conducting, current in the coil stops because X1 is part of the series circuit. By the time the coil field collapses, both transistors are in cutoff and the counter-emf cannot cause reverse current flow in the transistors. With two transistors,



NEW SECO MODEL 88 TESTS PICTURE TUBES, TOO!

- Tests over 400 cathode ray picture tubes including 110° deflection types for
 - cathode emission
 - leaks and shorts
 - grid emission
 - gas error
 - filament continuity
 - cathode-to-heater emission
- Tests all receiving tubes including novars, nuvistors, 10 pin types, compactrons and magnovals for
 - cathode emission
 - leaks and shorts
 - grid emission
 - gas error
 - filament continuity
 - cathode-to-heater emission

Seco's patented Grid Circuit Test alone makes up to 11 simultaneous checks for tube faults. Tube Merit and Filament Continuity tests increase the test range even more—you locate those "hard to find" faults on your first try.

And now this same tester handles picture tubes, too. Merit test operates at half of rated cathode current—no possibility of damage if filament voltage is correct. Indicates leakage, gas, shorts and grid emission—tapping the tube neck shows up intermittent shorts. Even handles 110° deflection models with universal socket adaptor.

This *COMPLETE* tester saves you time and trouble—does more jobs quicker and better. New Model 88 comes to you with speed-indexed setup data, pin straighteners and 12-pin picture tube socket on a 3-foot cable. Guaranteed up-to-date—new tube data mailed periodically at no charge to all registered owners.

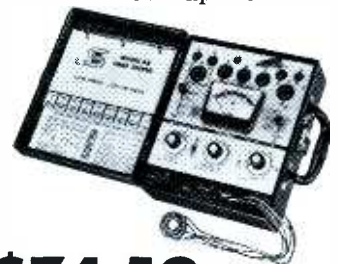

MODEL 88 - - - \$74.50 NET



For complete information see your distributor or write:

SECO ELECTRONICS, INC.
1221 S. CLOVER DRIVE • MINNEAPOLIS 20, MINNESOTA
A DIVISION OF DI-ACRO CORPORATION

Circle 49 on literature card

the breakdown rating of the circuit is increased considerably, and an extremely high voltage can be generated by the coil.

To aid further in preventing transient-voltage problems, zener diodes M1 and M2 shunt counter-emf pulses around the transistors

Triples and Up

There are two general types of systems using three or more transistors. The most popular of these uses an arrangement very similar to that shown in Fig. 6 except that the transistors are stacked three deep in series with the coil primary. Transistor biasing, keying, and protection are all accomplished exactly in the manner of Fig. 6.

The second type uses a circuit like that in Fig. 6 to pulse the coil—two transistors in series with the primary. Instead of using the breaker points to shift bias to cutoff, however, this circuit variation uses a third transistor. The result is the same. The breaker points open, and shift bias on the keying transistor. This in turn removes bias on the two main transistors, cutting them off and halting current flow in the ignition coil.

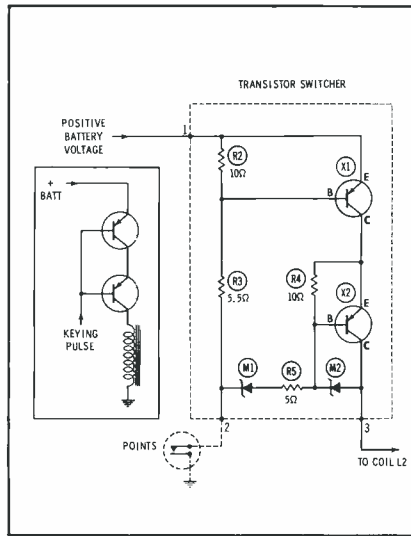

Fig. 6. A two-transistor switcher makes possible the use of a coil of much higher voltage.

Finding Defects

The most prevalent breakdown in transistorized switchers is proving to be in the transistors themselves. The temperature in and around automobile engines is extremely high, often more than transistors can stand. The better installations include a heat sink of some sort, and it should be installed somewhere away from the engine block. If a mounting can be found that permits

the radiator fan to blow air over the heat sink, so much the better.

Anyway, the most common trouble is a shorted transistor. This being so, quick servicing technique would mean a check of the transistors and zener diodes should come first. This saves a lot of time otherwise spent hunting for obscure troubles.

If all semiconductors check okay, then start troubleshooting in logical steps. Here is a procedure that will prove both fast and effective.

Disconnect the points lead and the coil lead (terminals 2 and 3). In series with the coil, install an ammeter having a range of 0-20 amps. DO NOT let the ammeter leads touch ground at any time; damage to the transistors could result. Attach a jumper to terminal 2 of the switcher. By grounding this lead we can simulate closed points; by unclipping it, open points.

For the first test, disconnect one ammeter lead, leaving the coil out of the circuit entirely. Clip the terminal 2 jumper to ground, simulating closed points. With your VOM, measure the bias between base and emitter of X1. You can

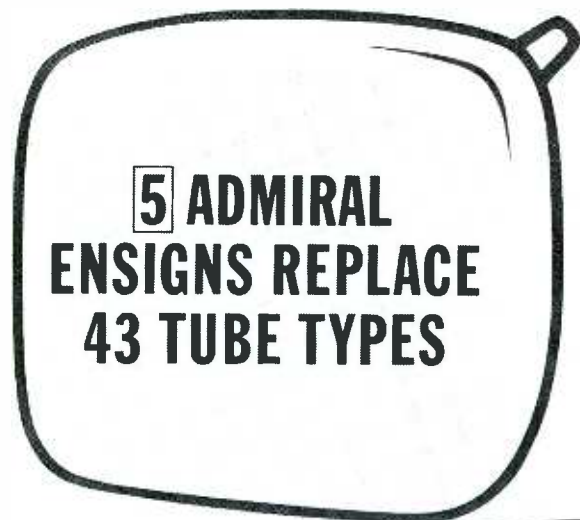

ENSIGN 17BJP4 REPLACES	17ATP4 17ATP4A 17AVP4	17AVP4A 17BUP4 17CBP4	17CLP4
ENSIGN 21AMP4 REPLACES	21ACP4 21ACP4A 21AMP4	21AQP4 21AQP4A 21CUP4	21BSP4
ENSIGN 21CBP4A REPLACES	21FLP4 21ALP4 21ALP4A 21ALP4B 21ANP4 21ANP4A	21ATP4 21ATP4A 21ATP4B 21BAP4 21BNP4 21BTP4	21CBP4B 21CMP4 21CVP4 21CWP4 21DNP4 21CBP4
ENSIGN 24CP4A REPLACES	24ADP4 24CP4 24QP4	24ATP4 24VP4 24VP4A	24XP4
ENSIGN 24AEP4 REPLACES	24DP4A 24YP4	24ANP4 24ZP4	

REDUCE INVENTORY! INCREASE SALES!

Save space, save dollars! Make more profit per sale with the Admiral ENSIGN "Big 5" as your basic tube inventory. All materials and parts used in the manufacture of these tubes are new except for the envelopes, which prior to reuse, have been inspected and tested to the same standard as new envelopes. Every Admiral ENSIGN tube is of fine/precision quality manufacture.



Call your ADMIRAL DISTRIBUTOR tomorrow... start cutting inventory cost, pocketing new profits right away!

Be wise... standardize on

ADMIRAL®
ENSIGN

REPLACEMENT PICTURE TUBES

Always Fine/Precision Quality

Circle 50 on literature card

determine what should be normal by using Ohm's law to calculate the comparative drops across the divider resistors.

If you're servicing a unit with two or three transistors wired as in Fig. 6, you'll have to reconnect the ammeter to measure bias on X2 (and X3) because current must be flowing through X1. If bias on X2 isn't normal, clip a jumper between the emitter and collector of X1, bypassing any effect X1 may have on the bias of X2. (If you have one of the triple-stacked configurations, another clip across X2 will enable an accurate check of the X3 bias circuit.) Bias on X2 (and X3) should be approximately the same as on X1, allowing all transistors to saturate.

If bias is okay on all transistors, turn your attention to the ammeter. Current should be about 10 amps, the exact amount depending on ballast resistors and the transistors used. If it is low, check any ballast resistors in the circuit. If they are okay, and no suppressor capacitors are leaky or shorting, the coil may be defective.

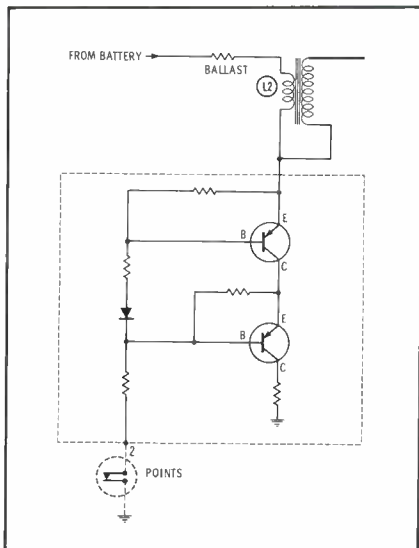

Fig. 7. If coil is between switcher and supply, and not grounded, circuit is "hot coil."

Next, unclip the lead from terminal 2 of the switcher, simulating open points. The ammeter reading should drop immediately to zero. If even slight current remains, you have a leaky transistor, a faulty zener diode, or a bias defect preventing complete cutoff. Current with the points open should be only a few microamperes, not enough to cause even a slight indication on the 0-20 ammeter.

These troubleshooting steps will reveal almost any fault you might encounter in a transistorized ignition system switcher. If you have to service circuits not shown here, remember these general rules: Keying of the transistors is always in the base circuit, even in "breakerless" systems that use amplified pulses developed in magnetic distributors. The emitter-collector circuits of the main transistors are always in series with the coil.

Watch for variations of familiar circuits. For example, the schematic of Fig. 7 shows a switcher exactly like that of Fig. 6, but the coil primary is between the switcher and the battery source. The system in Fig. 7 is called a "hot-coil" circuit, and is seldom used. Servicing would remain the same for either.

The popularity of transistorized ignition systems is on the rise, despite heat problems. If you're asked to service one, make sure the transistor and its heat sink are mounted in as cool a spot as possible before you finish the job; you'll save yourself some callback headaches. You'll find the extra business a fine supplement to your present profits. ▲

FIDDLESTICKS

or fiddlesticks? Call them what you will . . . it still takes more than your ears and a stick to get proper channel separation on stereo FM. Your ears alone cannot tell you when you've reached the maximum demanded by your customers.

Hickok's new model 727 is the most important piece of test equipment you can own. Only the Hickok 727 features:

- 35db minimum channel separation
- crystal-controlled 19 kc pilot at standard 10% level, switchable to 5% level for muting checks
- 67 kc, 19 kc and 38 kc test signals for complete alignment service
- output at either RF (100 mc tunable) or audio composite

THE HICKOK ELECTRICAL INSTRUMENT CO.

10566 Dupont Avenue
Cleveland, Ohio 44108

Represented in Canada by Stark Electronics, Ajax, Ontario
Internationally by Hughes International, Husint, S. A.,
Culver City, California

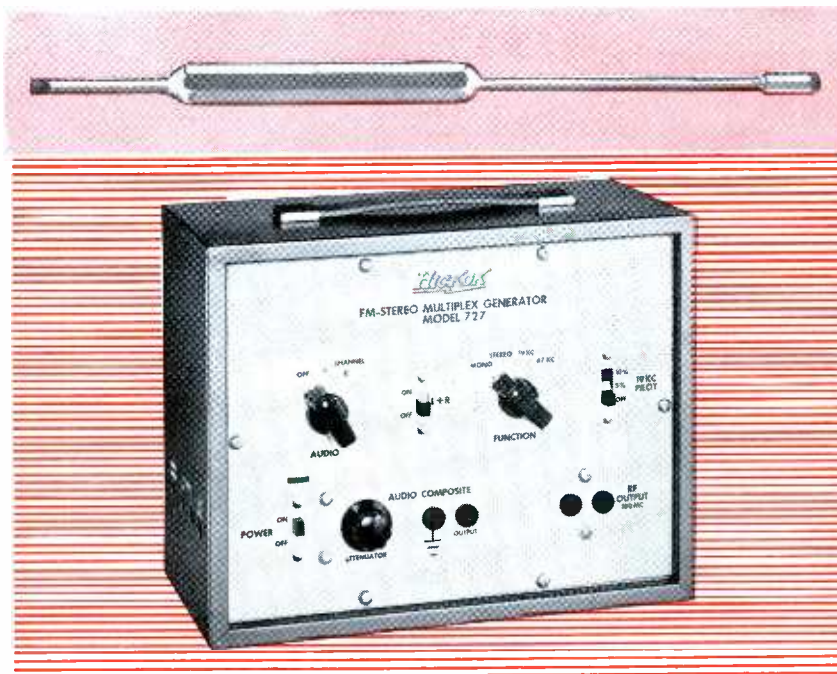

HICKOK

Hickok's new Model 727 takes the confusion out of Stereo multiplex. It's transistorized and completely portable, too.

MODEL 727 \$199⁹⁵

Your Hickok distributor has it in stock now!

Circle 51 on literature card

AFC Systems for FM

(Continued from page 35)

properly and the local oscillator is running at its correct frequency. The correction voltage applied to the cathode of X1 is zero, and the total voltage across X1 is the fixed bias voltage of -2 volts.

The ratio detector in this receiver produces a negative correction voltage when the oscillator drifts to a higher frequency. Assume this voltage to have a value of $-.5$ volts after it has been filtered and applied to the cathode of X1. The total voltage across X1 is reduced to -1.5 volts, since -2 volts is already applied to the anode. The capacitance of X1 increases because the charges in the P- and N-type

materials move closer to the junction. The total capacitance now shunting the oscillator tank circuit increases; therefore the resonant frequency of the oscillator is lowered. The oscillator will shift to its correct frequency since the correction voltage is proportional to the amount of oscillator drift.

When the oscillator drifts to a lower frequency, the correction voltage applied to the cathode of X1 will be positive: $.5$ volt, if the oscillator frequency lowers by the same amount it raised in the previous example. The total voltage across X1 would be 2.5 volts, since the correction voltage at the cathode adds to the -2 volts fixed bias on the anode. The capacitance of

X1 decreases because the mobile charges are pulled farther away from the PN junction. The lower total capacitance shunting the oscillator tank increases the oscillator resonant frequency by just the right amount to compensate for the drift.

AFC Defeat

An AFC defeat switch is inserted at the junction of R2, C7, and R3. The AFC correction voltage is held at zero when the switch is closed, disabling the control system. The reason for defeating the AFC is to make it possible to tune a weak FM station that may be near a strong one in the band. Since AFC causes "broader" tuning, it would be otherwise impossible to pick up the

styled to blend with any tv set

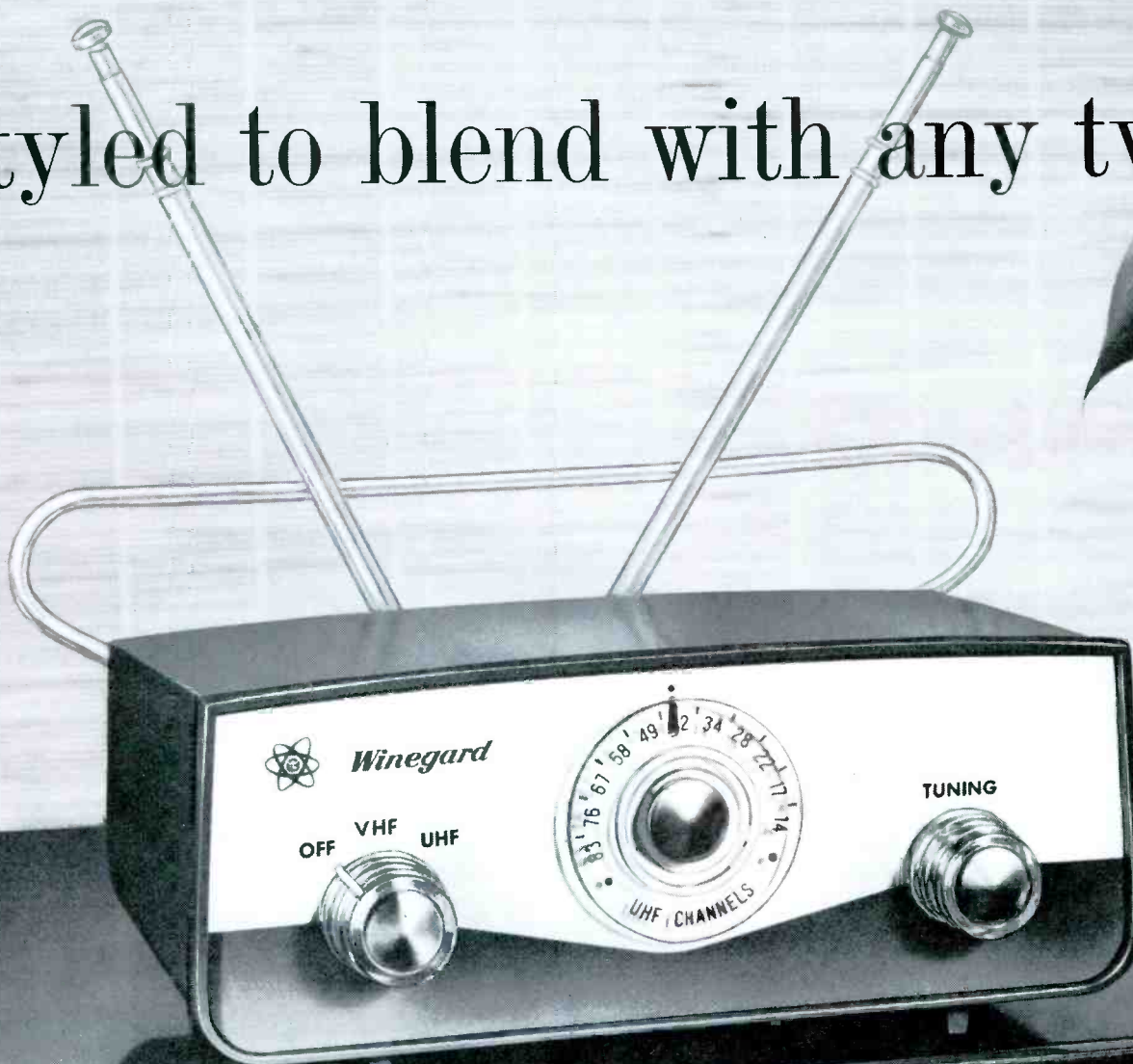

weaker signal because the AFC circuit would pull the oscillator to the stronger signal and "swamp" the weaker signal.

A Circuit Variation

A different AFC circuit is shown in Fig. 3. This circuit is similar to that of Fig. 2 since both use a variable capacitor device to control the local oscillator frequency.

These two circuits differ in this respect:

1. Fixed bias is obtained from a different source.
2. The ratio detector produces a *positive* DC correction voltage when the oscillator drifts above center frequency and a *negative* component when the oscillator drifts below.

The reverse is true of the circuit in Fig. 2.

In Fig. 3, C1 and L1B form the main oscillator tank circuit. The cathode of X1 is at RF ground, since C3 has very low reactance to local oscillator frequencies. Capacitor C2 and variable capacitance unit X1 thus form a shunt capacitance across the oscillator tank.

Resistors R1 and R2 are part of a voltage divider network that reduces B+ voltage to 5 volts, to bias X1 in a reverse direction. The correction voltage that varies the capacitance of X1 is applied to the anode.

The audio portion of the detector output is filtered out by R3 and C4. When the oscillator frequency drifts

upward, the correction voltage is positive and decreases the reverse bias. This increases the capacitance value of X1, lowers the resonant frequency of the oscillator tank, and pulls the oscillator back to its correct frequency. When the oscillator drifts to a lower frequency, a negative correction voltage decreases the capacitance of X1, causing the oscillator to shift upward to its correct frequency.

Service Hints

There is less chance for trouble to develop in an AFC system that uses a variable capacitance than in an older one which employs a reactance tube type of AFC. The reasons for this are the fewer parts

Winegard uhf converters

6 HIGH PERFORMANCE UHF CONVERTERS REGULAR AND AMPLIFIED WITH BUILT-IN UHF AND VHF ANTENNAS

Now Winegard engineering, styling and merchandising have combined to bring you the finest UHF converters on the market. Models UC-100A (one tube) and UC-200A (two tube) have built-in UHF and VHF antennas to receive all channels 2-83. Models UC-310 and UC-410 have a transistorized pre-amplifier that improves signal-to-noise ratio up to 12 DB. All models are furniture styled in handsome polystyrene cases in rich autumn brown trimmed with brushed gold. *Look at these features:*

- 3 gang capacitive tuning element eliminates sliding contacts in main circuit.
- Oscillator has new 6DZ4 tube... no drift, no microphonics... has better performance and longer life.

- Safe, cool chassis—isolated power supply with silicon rectifier.
- Only cabinet that is *completely* enclosed.
- Lowest noise 1N82A mixer diode • Exceed FCC radiation requirements • Exact 300 ohm impedance match
- Work perfectly with color or black and white

Models UC-200, UC-200A, UC-310 and UC-410 UHF converters have AC receptacle for TV set with "on-off" control that turns on TV set and also switches to UHF or VHF. All models have a built-in dial light.

Ask your distributor or write today for specification sheets on Winegard UHF converters.

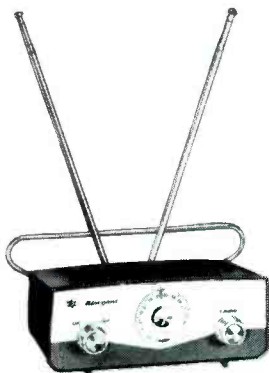

Model UC-100 UHF converter (one tube) \$29.95

Model UC-100A UHF converter (one tube) with built-in UHF and VHF antennas \$34.95

Model UC-200 UHF converter (two tube) with nuvistor IF amplifier stage \$42.50

Model UC-200A UHF converter (two tube) with nuvistor IF amplifier stage and built-in UHF and VHF—antennas \$47.50



Model UC-310 high gain converter with built-in transistor RF amplifier and nuvistor IF amplifier—improves signal-to-noise ratio up to 12 DB \$64.95

Model UC-410 high gain converter with built-in power supply, nuvistor IF amplifier and remote transistor RF pre-amp for mounting on antenna or anywhere along transmission line. For very weak signal areas, this is the most sensitive UHF converter made. \$69.95.

World's most complete line of TV-FM reception equipment



Winegard Co.

3009B KIRKWOOD BOULEVARD, BURLINGTON, IOWA

Circle 52 on literature card

Table I—Servicing FM AFC

Procedure	How	Why
Disable AFC.	Short correction voltage line to ground.	Permits checking normal operation of RF, IF, oscillator, and detector.
Check alignment of RF, IF, oscillator, detector.	Use alignment equipment, and station signals, to assure a zero output from detector when set is on-frequency.	Assures that tuned circuits are not maladjusted beyond pull-in capability of AFC.
Measure polarity and value of "resting" bias across variable capacitance.	Use VTVM directly across unit.	Indicates whether fixed bias is normal and correct.
Reactivate AFC.	Remove short from correction voltage line.	Enables troubleshooting of AFC circuit.
Check action of correction voltage applied to diode.	Use strong signal from generator, and use signal on both sides of center frequency indicated on receiver dial. VTVM across variable capacitance as an indicator.	Can eliminate possibility that correction voltage line is open or shorted.
Check leakage in coupling capacitors associated with variable unit.	Open lead farthest from voltage, and check with VTVM.	Slightest leakage can upset operation of unit.
Replace variable capacitance if it is suspected defective. Use heat sink. Disable AFC and realign set.	Short correction voltage line to ground, and adjust oscillator to receive stations at correct point on dial.	Different voltage-variable unit may affect alignment.

and the lower voltages.

It is important to use an exact replacement if the variable capacitance unit turns out to be the cause of trouble in the AFC circuit. The range over which the capacitance can be varied is important since the capacitance device is part of a tuned circuit. Substituting the wrong type won't tell you if the original unit is defective.

Check for leakage in DC blocking capacitors, such as capacitor C2 in Fig. 3. Even a slight amount could keep the oscillator "pulling." These semiconductor devices also have a maximum voltage rating; the unit will be damaged if it is exceeded.

Be sure to use a heat sink (such as a pair of longnose pliers) if soldering becomes necessary, for the unit will be damaged if excessive heat is applied.

The chart in Table I lays out a logical troubleshooting procedure. AFC systems are no longer complicated or difficult to service. Through understanding basic operation, the competent technician can adapt the information given in this article to any variation of the variable-capacitance AFC system. ▲



**IEEE
SHOW
'64**



march 23-26
9:45 A.M. - 9 P.M.

TWO BIG SECTIONS

at the

**NEW YORK
COLISEUM**

all 4 floors!

- ELECTRONICS EXHIBITS
- CONVENTION PAPERS

See the finest products of industry, hear famous men speak! Just one entrance fee lets you visit both sections.

Buses to the N. Y. Hilton every few minutes

PRODUCTS • PAPERS • PEOPLE • PRODUCTS • PAPERS • PEOPLE

Color CRT

(Continued from page 36)

technicians in the shop, and they were free with their voiced opinions and explanations—both wild and practical. But George, who believes in deeds rather than words, stopped speculation cold by turning down the green and red grids of the picture tube together with a clip lead. Immediately, both the red and green dots were missing from the left edge of the picture!

With one simple test, George had made it quite obvious that the trouble was being caused by some defect in the R-Y circuit. Knowing which stage was troubled led to quick location of the bad component—the 10K plate load resistor in the R-Y amplifier (R3 in Fig. 2) was open.

Of course, a new resistor restored the missing red dots, but much head scratching and many cups of coffee were necessary before everyone understood why. Finally, we redrew the schematic of this plate circuit, as shown in Fig. 3. Now, the *why* became clear: Even though R3 was

open, a small amount of plate voltage for V1 was supplied from the CRT bias control, via R4 and R5. This high resistance reduced the high frequency response of the amplifier, and broadened the horizontal blanking spike (inserted at the cathode) until it blanked part of the red raster—those missing red dots. Naturally, the B-Y and G-Y amplifiers were operating normally, so the blue and green rasters weren't effected.

Needed—A Double Check

The next "close shave" started innocently enough. A wealthy farmer brought his Zenith color receiver (Chassis 29JC20) to us, with the comment that his local serviceman had diagnosed the trouble as a bad picture tube; he had recommended that we install a new one. The set owner said he would like to take the receiver home with him that evening, then left to go shopping. Following our standard policy, we turned on the set to see for ourselves.

The screen showed nothing for almost three full minutes; then finally a dim and defocused picture appeared. In another five minutes

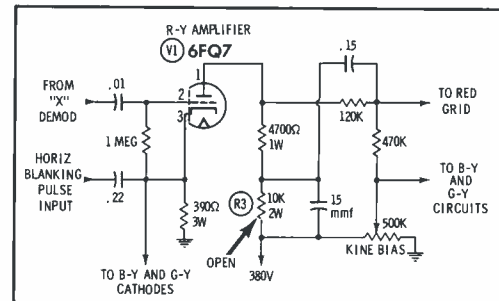

Fig. 2. Horizontal blanking pulse passes through color difference amplifiers to CRT.

the picture had brightened up, with normal brightness and focus. Yes, it looked like the tube was weak, all right, yet my little alarm bells chimed their faint warning. When had the telltale crackle of the high voltage sounded? It can usually be heard about 40 or 50 seconds after the set is turned on, but this time the crackle had taken three minutes. (It wasn't very loud either.) This did look like high voltage trouble, and as the picture tube was too hot to check for emission just then, we pulled the chassis and reconnected it with extension cables.

The scope and VTVM were connected so as to monitor the horizontal drive waveform and boost voltage during warmup. In one

ONE GREAT SHOW!

at the
**NEW YORK
HILTON**

2 floors, including Hilton's
main exhibition area

- ELECTRICAL EXHIBITS
- CONVENTION PAPERS

IEEE Members: \$1.00
Non-members: \$3.00
Minimum age: 18

Buses to the N. Y. Coliseum every few minutes

• PRODUCTS • PAPERS • PEOPLE • PRODUCTS • PAPERS • PEOPLE



IEEE SHOW '64

march 23-26
9:45 A.M. - 9 P.M.

Circle 53 on literature card

Winegard Dealer of the month

Ed Lauzon says, "It is nice to sell an antenna and know it is out to stay."



Winegard salutes Ed Lauzon of Bee TV, Longview, Washington and their distributor, C & G Electronics of Tacoma, Washington.

Successful Ed Lauzon, owner of Bee TV, is an established dealer who covers the entire area in and around Cowlitz County. His headquarters are at 362 Oregon Way, Longview.

Mr. Lauzon operates a modern service business and consistently features Winegard Colortrons in his advertising.

Speaking of his Winegard Antennas he says, "Best antenna made! Cowlitz County has needed an antenna like Winegard Colortron for years."

Ed Lauzon likes the rugged Colortron quality and its standard of excellence. He adds, "It is nice to sell an antenna and know it is out to stay."

FM and FM Stereo, growing as they are in popularity, bring him additional business. That's Winegard Stereotron Antenna next to the Colortrons ready for loading in a Bee TV service truck in the photograph above.

Winegard
Antenna Systems

D3009-B Kirkwood • Burlington, Iowa
Circle 54 on literature card

minute the horizontal oscillator was working fine (and on frequency), but boost voltage was nil. In two minutes, boost read 100 volts, and was climbing slowly. After three minutes had elapsed, boost was almost normal and the picture came on—slightly blurred and about 1/2" short of width. The trouble should have been obvious to me by then, but on Monday morning other things besides TV pictures are sometimes blurred. The phone rang, and I shut the set off.

When I came back from answering the phone, the picture tube was cool enough to check. Finding all three guns to have acceptable emission, I returned my thoughts to the boost circuit. Boost voltage should have measured as much as the main B+ voltage within one minute—even if the yoke was shorted or the flyback transformer was bad. Hazy thinking told me it couldn't be the damper tube, since the left side of the picture wasn't stretched out of linearity. Or could it be . . . ? It took only a few seconds and a new 6AU4 to prove that it could be—and was.

It wasn't my fault for overlooking such a simple thing. After all, color sets are *supposed* to be complicated . . . aren't they?

Watch The Others

A kindly providence is always at work to keep my hat size from enlarging, for the next case also helped replenish my supply of humility.

It seemed a routine tube-changing call on a RCA CTC9 chassis, for the complaint was: no raster, good sound. The heaters of the picture tube were lit, and I could draw a big, snapping arc from the high voltage anode, so I immediately

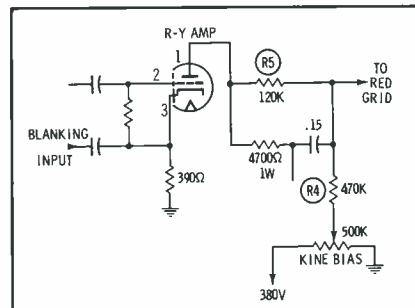

Fig. 3. Simplified schematic of R-Y amplifier.

suspected video trouble. However, the DC voltage at the plate of the 12BY7 output tube varied from 250 to 340 volts as I rotated the brightness control from maximum to minimum; and this test normally clears the entire video circuit of suspicion in one short step.

It is rare for a trouble in the chroma circuit to cause a loss of raster, but I checked the three CRT grids to make sure. They were all between 190 and 210 volts—just as they should be. Picture tube screen voltages? Normal.

Our carry-in tool kit includes a high voltage probe for measuring DC voltages up to 50 kv; so I unpacked it, connected it, and rechecked the high voltage. It was around 25 kv, and that's well within tolerance, too. With the probe still in my hand, I stopped and questioned myself: Are these all of the picture tube voltages? And: Should I maybe go back to the shop for the picture tube tester (I'd forgotten it)?

Then I finally remembered that a complete loss of focus voltage will also cause loss of raster. The voltage on the focus anode (pin 9) of the picture tube socket was zero. With a mighty foolish feeling, I installed a new 1V2 focus rectifier, touched

PRECISION TUNER SERVICE

P. O. BOX 272
BLOOMINGTON, IND.

1200 S. WALNUT ST.
EDISON 99653

7.50
V or U
COMBO PLUS
9.95 POSTAGE

6 MONTH WARRANTY



All Types T.V. Tuners Cleaned, Repaired and Aligned to Factory Specifications. Same day in shop service on most Tuners. Price Includes Minor Parts, Major Parts at Cost Price. We use Original Parts if possible. State Make Model and Enclose all Parts and Tubes. Pack Well and Insure.

ALSO HAVE LARGE STOCK OF EXCHANGE TUNERS, WRITE FOR TYPES AND PRICES.

Circle 55 on literature card

up the center convergence, collected the bill, and left.

Troubles and Troubles

This next case was probably the hardest I've had lately to diagnose because there were multiple sources of trouble instead of just one. George had a new RCA CTC15 chassis he brought in for picture tube replacement. He said with a slightly malicious smile, "The whole neck of the tube lights up blue from gas. Let's see you make a chassis trouble out of this one."

Well, he had me there, so we installed a new tube and then stood back calmly as we waited for the screen to light up. And it certainly did—for one whole second—then it bloomed out and disappeared. Dark thoughts about picture tube manufacturers flashed through our minds as we contemplated installing a second tube. But our experience had made us doubly cautious by now, so we removed the socket from the CRT and heard the crackle of returning high voltage. It still looked like the new picture tube was bad.

Checking the voltages on the socket pins, we discovered 400 volts on the green grid (pin 6), instead of the normal 160 volts. Then we noticed what would have been obvious if we hadn't been preoccupied with thoughts of picture tubes—the 6GU7 (G-Y amplifier-blanker) was not lit; it had a glass crack across the base. Our courage returned as we replaced it with a new tube, but the picture came on slightly green. Within a space of fifteen seconds, the screen turned a vivid bright green until the picture bloomed and we lost high voltage again. Impossible? We thought so, too. This time, the voltage on the green grid measured normal, so we unplugged the picture tube socket and checked all the pin voltages; grid, cathode, screen, and focus pins all had normal voltages.

When the socket was again connected, the picture came on and bloomed out as before. We connected our switch box that shunts each grid to ground through a 100K resistor; with the green switch off, the picture was still a little green, but it did not bloom out. The red and blue screen controls varied their respective colors, but turning the green screen control had *no effect!* However, with the socket removed to make testing easier, the voltage

could be varied normally with the control. The trouble *had* to be in the green screen circuit, but where?

I was turning the picture tube socket over idly in my hands when my little alarm bell rang! Was there something different about the pins on the socket? Yes, there was: the green pin was much farther back inside the socket than the other pins. It took only a few minutes of work with a soldering-aid to push the pin back into line. This time the set worked fine, with no green blooming.

Our hindsight was working effi-

ciently, for we concluded that the bad socket might have caused all of the troubles. The bad pin connection caused the floating green screen to assume a charge from the focus electrode, until it had gone highly positive—causing the excessive green brightness. The owner had not shut off the set promptly when it bloomed, and the picture tube became gassy from the heavy overload. The gassy condition caused an arc that also flashed across the 6GU7 base, cracking the glass.

Anyway, I still like to work on color sets. Don't you? ▲

Model 501 COMPONENT SUBSTITUTOR

...places a complete range of components at your fingertips

NEW





for fast substitution

only

\$3750

Slightly higher in the West

All hand wired ...
All American made

Will substitute up to 4 different components at the same time

A surge protector switch prevents arcing, sparking, or heating of electrolytics

Electrolytics are discharged automatically

The Model 501 provides all the substitutes for electronic components you want and need in your every day work ... more than any other instrument of its type. No longer do you have to handle hard-to-manipulate crumpled parts ... solder and unsolder components as you trouble shoot a set. With a twist of a knob and a flip of a switch you can set the 501 to any one of over 80 component values ... substituting as many as four different components simultaneously. Smart, sturdy grey hammertone steel housing ... handy storage compartment accommodates the insulated test leads provided with the instrument. Size: 10" wide x 6 1/4" high x 4 1/2" deep.

SUBSTITUTES FOR:

CARBON RESISTORS
 12 VALUES 1 watt: 10/18/33/56/100/180/330/560/1000/1800/3300/5600 ohms
 12 VALUES 1/2 watt: 10,000/18,000/33,000/56,000/100,000/180,000/330,000/560,000/1,000,000/1,800,000/3,300,000/5,600,000 ohms

POWER RESISTORS (20 watt Wire Wound)
 20 VALUES: 2.5/5/7.5/10/15/25/50/75/100/150/250/500/750/1,000/1,500/2,500/5,000/7,500/10,000/15,000 ohms

CAPACITORS (600 volts)
 12 VALUES: .0001/.0005/.001/.0025/.005/.01/.015/.02/.05/.1/.22/5 mfd.

ELECTROLYTICS (450 volts)
 17 VALUES: 4/8/10/12/14/18/20/28/30/40/50/70/80/130/150/200/230 mfd.

RECTIFIERS (Universal)
 CRYSTAL DIODES—all general purpose low voltage types
 SELENIUM POWER RECTIFIERS—up to 500 ma., 800 PIV
 SILICON POWER RECTIFIERS—up to 750 ma., 800 PIV

See your electronics parts distributor or write for complete literature



111 Roosevelt Avenue, Mineola, New York

Circle 56 on literature card

Product Report

For further information on any of the following items, circle the associated number on the Catalog & Literature Card.

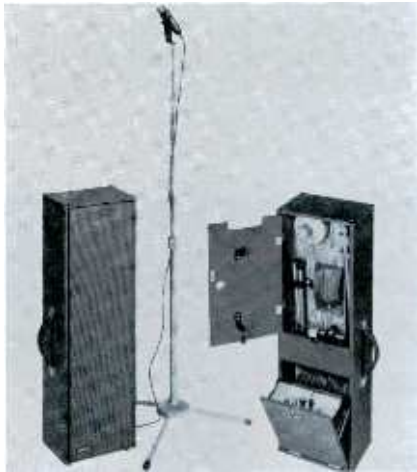

Portable PA System (65)

A 25 watt, battery-powered amplifier, six speakers, and a microphone with 18' cord, floor stand, and lavalier, are the components of a PA system built by **Argos Products**. Contained in a rugged case measuring 29 $\frac{3}{4}$ " x 9 $\frac{3}{4}$ " x 6 $\frac{7}{8}$ ",

the "Voice Director" operates up to 400 hours on alkaline flashlight batteries, and is priced at \$283. A separate "Satellite Sound Director" sound column is available at \$91.50, as an optional addition to the basic system.

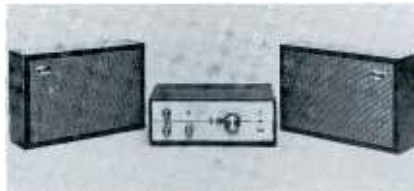

FM Stereo Receiver System (66)

An FM stereo tuner-amplifier with inputs for phono and tape recorder, plus a pair of 2-way speaker systems in oiled walnut cabinets, make up a new stereo package from **EICO**. Termed the Model 2510, the tuner features an illuminated rotary tuning dial, a bar-type electron-ray tuning and stereo program indicator, a four-position input selector, and tone and loudness controls. The stereo system specifications include: channel separation

of 30 db; sensitivity of 1.5 uv for 20 db quieting, and 10 uv for full limiting; IF bandwidth of 280 kc at 6 db points; and IHFM signal-noise ratio of 55 db. Priced at \$199.95, the system frequency response is 20-40,000 cps ± 1 db at 10 watts, and noise is 80 db down.



Infinite-Resolution Trimmers (67)

A $\frac{1}{2}$ " diameter subminiature trimmer has been added to the line of infinite resolution potentiometers manufactured by **International Resistance Co.** Known as the "Circuitrim 150" the new unit uses a thick film of precious metal alloys for its resistive element. It has a standard range of 100 ohms to 1 megohm with tolerances of $\pm 5\%$, $\pm 10\%$, and $\pm 20\%$, and a power rating of $\frac{3}{4}$ watt. The high resistivity of the material from which the unit is made allows resistance ranges far beyond that feasible with wire. "Circuitrim 150" is available in screwdriver-adjust or fingertip-adjust models.

SAVES
your back...
SAVES
your time...



YEATS SHORTY DOLLY for RADIO and TV

just 47 inches high for STATION WAGONS and PANEL PICK-UPS



FOLDING PLATFORM
15 $\frac{1}{4}$ " x 24 $\frac{1}{2}$ " top.
Snaps on or off.
(Platform only)
\$11.95

Designed for TV, radio and appliance men who make deliveries by station wagon or panel truck... the short 47 inch length saves detaching the set for loading into the "wagon" or pick up. Tough, yet featherlight aluminum alloy frame has padded felt front, fast (30 second) web strap ratchet fastener and two endless rubber belt step glides. New folding platform attachment, at left, saves your back handling large TV chassis or table models. Call your YEATS dealer or write direct today!



YEATS Model No. 5
Height 47"
Weight 32 lbs.



FURNITURE PAD

"Everlast" COVER AND PADS

YEATS semi fitted covers are made of tough water repellent fabric with adjustable web straps and soft, scratchless white flannel liners. All shapes and sizes — Write



TV COVER



APPLIANCE DOLLY SALES COMPANY

2103 N. 12th STREET MILWAUKEE, WISCONSIN

Circle 60 on literature card

5 CORES
WETS FASTER
MELTS FASTER
Solders Better
5-CORE SOLDER
WORLD'S FINEST

ERSIN
Multicore
A.I.C. ENDORSED QUALITY

Multicore Sales Corp. Part Washington, N.Y.

Circle 58 on literature card



Midget Tape Recorder (68)

A pocket-size, transistorized tape recorder—the TR-408—is designed for up to 30 minutes of recording time and needs less than three minutes for re-winding. Only 5½" x 3 9/16" x 2 1/16", this **Craig-Panorama** recorder offers double-track recording, variable tape speeds, and an ultrasensitive microphone. Four penlight batteries, which slide in or out of a neat package, power the unit. Furnished complete with telephone pick-up, earphone, batteries, remote control from the microphone, four full tapes, and a takeup reel, the Craig TR-408 is dressed in a genuine cowhide carrying case with hand and shoulder strap. The unit itself is finished in brushed metal, chrome, black, and gray, weighs less than 2½ lbs, and has a suggested list price of \$54.95.

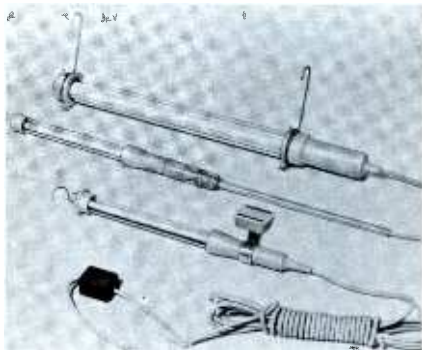

Fluorescent Safety Lamp (69)

A new safety lamp, a fluorescent extension light made by **K & H Co.**, is now available in five different wattages and with a variety of accessories. There

are now 6, 8, 13, 20, and 40 watt models. The 20 and 40 watt units are equipped with hang-up hooks at both ends, permitting suspension for area lighting. Each model features a fluorescent tube mounted on shock absorbers and housed within a rugged, plastic shield. Cap, handle and cord are all neoprene rubber. This construction eliminates electrical shock hazards, and reduces fire and explosion dangers. Watertight seals, achieved without the use of sealants, permit the unit to be fully submerged. The cool, shielded fluorescent tube presents no problem of contact burns or of cuts or contamination from broken glass.

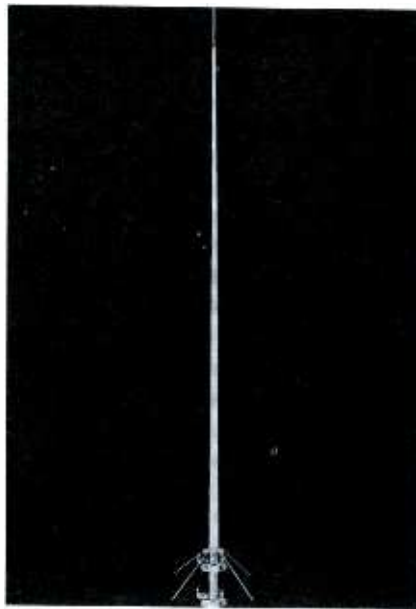

Two-Way Antenna (70)

The Type 150, a new omnidirectional high gain antenna for 150-162 mc operation, has been announced by the **Andrew Corp.** Designed for mobile communication service, this antenna features 6 db gain and a 3 mc bandwidth with less than 1.5:1 VSWR in each of its four lobes, and up to 5 mc with a 2:1 VSWR. No field tuning or adjustments are necessary. A fiberglass covering protects the radiating elements, yet permits moisture drainage. Lightweight, heavy duty design assures resistance to winds up to 125 mph.



New FM Antenna Package (57)

Created for eye-catching appeal at the point of sale, this colorful purple and white display carton is now used for packaging all **Clear Beam** FM stereo antennas. Large, easy-to-read print stresses the importance of an FM antenna in securing balanced multiplex and monophonic reception; also pointed out are the benefits of improving performance of eliminating fade, shift, and distortion.

INDEX TO ADVERTISERS

ATR Electronics, Inc.	12
Acme Electric Corp.	66
Admiral Sales Corp.	70
Antennacraft Co.	48
Atlas Sound	64
B & K Mfg. Co.	45
Div. of Dynascan Corp.	
Belden Mfg. Co.	53
Berns Mfg. Co., Inc., The	66
Blonder-Tongue Labs	56
Bussmann Mfg. Div.	18, 19
Cadre Industries	40
Castle TV Tuner Service	14
Centralab, Div. of Globe-Union, Inc.	24
Channellock, Inc.	68
Channel Master Corp.	37
Cleveland Institute of Electronics	50
Cornell-Dubilier Electric Corp.	10
EICO Electronic Instrument Co., Inc.	65
Electro-Voice, Inc.	64
Enterprise Development Co.	64
Finney Co.	21
GC Electronics Co.	12
Hickok Electrical Instrument Co.	13, 71
IEEE	74, 75
Injectorall Co.	64
Jensen Mfg. Co.	57
Lafayette Radio Electronics Corp.	43
Littelfuse, Inc.	Cover 4
Mallory, P. R. & Co., Inc.	47
Mercury Electronics Corp.	77
Multicore Sales Corp.	78
Ohmite Mfg. Co.	42
Oxford Transducer Co.	44
Perma-Power Co.	62
Philco Corp.	
Parts and Service Operations	22, 23
Planet Sales Corp.	54
Precision Tuner Service	76
RCA Electronic Components and Devices	Cover 3, 63
RCA Institutes, Inc.	52
RCA Sales Corp.	61
Sams, Howard W. & Co., Inc.	58, 67
Sarkes Tarzian, Inc.	
Tuner Service	9
Seco Electronics, Inc.	69
SENCORE, Inc.	29, 39, 51, 55, 59, 79
Simpson Electric Co.	41
Sprague Electric Co.	16, 17
Standard Kollsman Industries, Inc.	Cover 2
Sylvania Electric Products, Inc.	15
University Loudspeakers, Inc.	49
Winegard Co.	72, 73, 76
Xcelite, Inc.	66
Yeats Appliance Dolly Sales Co., Inc.	78

MY BACK IS KILLING ME!
I'VE LUGGED THIS STUFF ALL DAY
AND STILL HAVE TWO CALL-
BACKS TO GO! MY TUBE CHECKER
LIED TO ME AND I
RAN OUT OF
TUBES FOR
SUBSTITUTION!

**WISE UP OLD BUDDY! GET
YOURSELF A MIGHTY MITE...
NEVER LETS YOU DOWN AND
IS AS EASY TO CARRY AS YOUR
LUNCH BOX! I MADE
10 CALLS ALREADY
AND SOLD FIVE
EXTRA TUBES I
WOULDN'T HAVE
CAUGHT BY
SUBSTITUTION!**

JOE'S TV SERVICE

YE OLDE TUBE TESTER

YE OLDE BEAT UP TON AND A HALF TUBE CADDY

MIGHTY MITE TC114

"Finds 'em Fast... Checks 'em All!" **SENCORE MIGHTY MITE**
NOW CHECKS OVER 2,000 TUBES TUBE CHECKER

Circle 59 on literature card



FREE Catalog and Literature Service

*Check "Index to Advertisers" for further information from these companies.

ANTENNAS & ACCESSORIES

71. **HY-GAIN**—Catalog showing complete line of antennas and accessories for VHF amateur communications equipment.
72. **JERROLD**—Short-form catalog describing wide line of TV-FM home distribution products, including preamplifiers, converters, matching transformers, etc.
73. **JFD**—Specifications and operating information on *Transis-tenna* and newly designed, long-range LPV log-periodic TV antennas. Illustrated brochure showing entire line of indoor antennas and accessories for TV and FM. Data sheets on UHF antennas.
74. **MOSLEY ELECTRONICS**—Illustrated catalog giving specifications and features on large line of antennas for Citizens band and amateur applications.
75. **SURFACE CONDUCTION INC.**—Brochures on *G-Line* single-wire transmission line and feeder systems for VHF, UHF, SHF, and amateur applications.
76. **TRIO**—Illustrated sheets showing line of antennas for TV and FM reception; also includes information on *Color-Brite* line of UHF antennas for color reception.
77. **ZENITH**—Informative bulletin on new line of log-periodic vee-type antennas for FM, and monochrome and color TV.

AUDIO & HI-FI

78. **ADMIRAL**—Parts and accessories catalog listing replacement components; also includes cross reference for phono needles and cartridges.*
79. **ATLAS SOUND**—Data sheet describing *Columair* sound columns for use in auditoriums, churches, and similar areas with acoustic feedback problems.*
80. **ELECTRONICS**—New Audiotex catalog No. 65-A, listing cables, connectors, and other hi-fi accessories.*
81. **GIBBS SPECIAL PRODUCTS**—Folders describing principles of sound reverberation and *Stereo-Verb* reverberation units for automobiles.
82. **HARTLEY-LUTH**—Product bulletin on line of full-range speakers and enclosures.
83. **JENSEN MFG.**—New 16-page, 2-color catalog No. 1090 containing information and specifications on expanded line of *Concert*, *Viking*, and *Weather Master* loudspeakers.*
84. **MINNEAPOLIS SPEAKER**—Descriptive catalog on *Red Line* hi-fi loudspeakers; includes information on weatherproof *Music Mini-Speaker* for indoor or outdoor use, and new 8" speaker.
85. **OAKTRON**—"The Blueprint to Better Sound," an 8-page catalog of loudspeakers and baffles giving detailed specifications and list prices.
86. **OXFORD TRANSDUCER**—Product information bulletins describing complete line of loudspeakers for all types of sound applications; including replacements for public address and intercom systems.*
87. **QUAM-NICHOLS**—New hi-fi catalog listing specifications and response limits for coaxial, extended-range, low-frequency woofer, and tweeter speakers, in addition to other components.
88. **SWITCHCRAFT**—Product Bulletin 136 describing new stereo adapter cables for converting sockets on European-made recorders, radios, amplifiers and pre-amps to mate with American-made headphones, microphones, and speakers.*
89. **UTAH**—Catalog listing complete line of speakers and accessories for high-fidelity and public-address equipment. Also contains speaker replacement data.

COMMUNICATIONS

90. **CADRE**—Catalog on *Betacom* line of intercom systems for office, industry, and home installations.*
91. **E. F. JOHNSON**—4-page, full-color brochure on new all-transistor *Messenger III* Citizens Band transceiver.
92. **PEARCE-SIMPSON**—Specification brochures on *Companion II* and *Escort* Citizens Band transceivers.
93. **POCKETRONICS**—Brochures describ-

- ing line of portable paging equipment: receivers, rechargers, encoders, adapters, and leather cases.
94. **REGENCY**—Information on newly introduced Citizens Band transceiver, and aircraft communications receivers.
 95. **SAMPSON CO.**—Specification sheet on CB base station and booklet containing information, schematics, and instructions for use.

COMPONENTS

96. **BUSSMANN**—Bulletin SFB; 24-page booklet giving detailed information on line of *Buss* and *Fusetron* small dimension fuses and fuseholders.*
97. **HEATH**—1964 catalog lists and describes over 250 audio, radio, and test equipment kits.
98. **JERSEY SPECIALTY**—Catalog on line of TV transmission cables and other wire products.
99. **MILLER**—General catalog and replacement guide No. 163, listing all types of components for electronic applications.
100. **MUELLER ELECTRIC**—Catalog No. 250 on complete line of alligator, test, and battery clips for electronics servicing.
101. **NATIONAL RADIO**—Catalogs listing special control knobs and RF chokes.
102. **ONEIDA ELECTRONICS**—Sheet showing line of miniature electrolytic capacitors for use in small electronics equipment.
103. **PERMACEL**—16-page condensed data book describing line of pressure-sensitive tapes; includes specifications, features, and uses.
104. **SONOTONE**—Specification sheet No. BA-139 on new fast-charging nickel-cadmium batteries.
105. **SPRAGUE**—Latest catalog C-615 with complete listings of all stock parts for TV and radio replacement use, as well as *Transfarad* and *Tel-Ohmike* capacitor analyzers.*
106. **TRIAD**—Product sheets on new TV replacement yokes having toroidal vertical windings.

SERVICE AIDS

107. **CASTLE**—How to get fast overhaul service on all makes and models of television tuners is described in leaflet. Shipping instructions, labels, and tags are also included.*
108. **PRECISION TUNER**—Literature supplying information on complete, low-cost repair and alignment services for any TV tuner.*
109. **STANDARD KOLLSMAN**—Tuner replacement guide, covering all TV sets from 1947 through 1962, with replacement parts listings.*
110. **WORKMAN**—Bulletins describing 1 amp and 6 amp transistorized battery chargers.
111. **YEATS**—The new "back-saving" appliance dolly Model 7 is featured in a four-page booklet describing feather-weight aluminum construction.*

SPECIAL EQUIPMENT

112. **ACME ELECTRIC**—Complete specifications and applications for control-type magnetic amplifiers with capacities from 5-1000 watts and voltage ranges from 24-160 volts.*
113. **ATR**—Descriptive literature on selling new, all-transistor *Karadio*, Model 707, having retail price of \$29.95. Other literature on complete line of DC-AC inverters for operating 117-volt PA systems and other electronics gear.*
114. **GREYHOUND**—The complete story of the speed, convenience, and special service provided by the Greyhound Package Express method of shipping, with rates and routes.
115. **PHILMORE**—Bulletin describes code oscillator with variable tone control; operates with built-in speaker or earphone.
116. **TERADO**—Brochure illustrating *Satellite* power inverter designed for operating

portable TV's from automobile, boat, and other low-voltage power sources.

117. **VOLKSWAGEN**—Large, 60-page illustrated booklet "The Owner's Viewpoint" describes how various VW trucks can be used to save time and money in business enterprises; includes complete specifications on line of trucks.
118. **WESTBURY CATV**—Brochure describing line of transistorized amplifiers and other distribution systems equipment.

TECHNICAL PUBLICATIONS

119. **CLEVELAND INSTITUTE OF ELECTRONICS**—"Pocket Electronics Data Guides" with handy conversion factors, formulas, tables, and color codes. Additional folder, "Choose Your Career in Electronics," describes home-study electronics training programs, including preparation for FCC-license exam.*
120. **HAYDEN BOOK CO.**—New 1964 catalog lists and describes books published by John F. Rider and Hayden Book Co.
121. **RCA INSTITUTES**—64-page book "Your Career in Electronics" detailing home study courses in TV servicing, communications, automation, drafting, and computer programming; for beginners and experienced technicians.*
122. **HOWARD W. SAMS**—Literature describing popular and informative publications on radio and TV servicing, communications, audio, hi-fi, and industrial electronics; including special new 1963 catalog of technical books on every phase of electronics.*

TEST EQUIPMENT

123. **B & K**—Catalog AP-21R describing uses for and specifications of new Model 1074 Television Analyst, Model 1076 Television Analyst, Model 850 Color Generator, Model 960 Transistor Radio Analyst, new Model 445 CRT Tester-Rejuvenator, new Model 250 Substitution Master, Model 375 *Dynamatic* VTVM, Model 360 *V-O-Matic* VOM, Models 700 and 600 *Dyna-Quik* Tube Testers, and Model 1070 *Dyna-Sweep* Circuit Analyzer.*
124. **EICO**—New 32-page, 1964 catalog of test instruments, hi-fi components, tape recorders, Citizens band, and amateur radio equipment.*
125. **ELECTRO PRODUCTS**—Catalog supplement No. 1 describing RB-500 power supply.
126. **GENERAL ELECTRIC**—Descriptive brochure No. 201-3 on portable tester for SCR's and silicon rectifiers. Application notes abstract No. 200.0 describing supplementary rectifier information.
127. **HICKOK**—Complete descriptive and specification information on newly introduced equipment—Model 662 installer's color generator; Model 580 portable tube tester; Model 727 multiplex generator; Model 235A portable field strength meter.*
128. **JACKSON**—Complete catalog describing all types of electronic test equipment for servicing and other applications.
129. **NATIONAL RADIO INSTITUTE**—Informative booklet entitled "How To Interpret Oscilloscope Specifications."
130. **SECO**—Product folder containing specifications and prices on line of tube and semiconductor testers.*
131. **SENCORE**—Question-and-answer bulletin on CA122 *Color Circuit Analyzer* and CG126 *Color Generator*.*
132. **SIMPSON**—Latest series of VOM's are described in test-equipment bulletin; also information on line of automotive test equipment.*

TOOLS

133. **AMERICAN ELECTRICAL HEATER**—Catalogs on *American Beauty* conduction soldering equipment and *Wasco Glo-Melt* resistance soldering equipment; booklet on "Principles of Resistance Soldering."
134. **ENTERPRISE DEVELOPMENT**—Time-saving techniques in brochure from Endeco demonstrate improved desoldering and resoldering techniques for speeding up and simplifying operations on PC boards.*

TUBES & TRANSISTORS

135. **AMERICAN ELITE**—182-page booklet containing characteristics of *Telefunken* tubes and semiconductors; includes comparative listings of European and American types.
136. **GENERAL INSTRUMENT**—Universal replacement and interchangeability guide for transistors; service dealers catalog on complete line of electronics products.
137. **SEMTRONICS**—New updated 16" x 20" wall chart CH10 lists replacements and interchangeability for transistors and diodes.

SEE HOW RCA RECEIVING TUBES KEEP GETTING BETTER

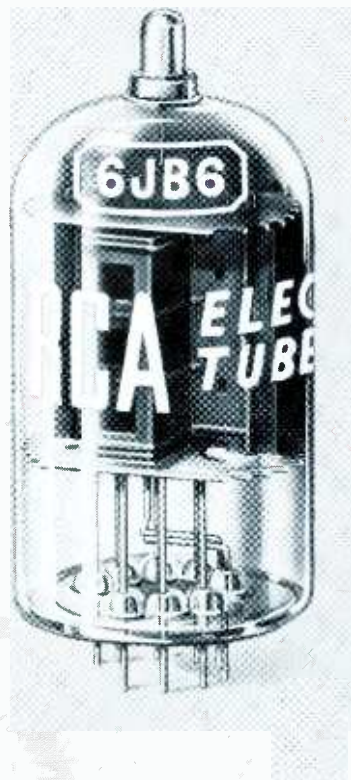

1959—*N-132 Cathode Base Material*
1960—*S-311 Plate Material*
1961—*RCA Dark Heater*

...AND 1963

THE BONDED CATHODE

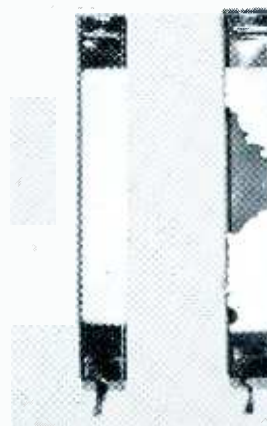

Ends cathode peeling, even after long periods of high-temperature, high-voltage tube operation.

Picture on right is an example of peeling which may occur in non-bonded cathode of a horizontal-deflection-amplifier tube after several hundred hours of operation in a TV receiver.

From RCA research comes another major contribution to electronic performance and reliability: the bonded cathode. Its emissive coating will not peel even after extended service under high-voltage, high-temperature conditions encountered in TV horizontal-deflection-amplifier tubes and damper diodes. Permanent adhesion of the emissive-oxide coating of the RCA bonded cathode improves over-all tube performance and reliability. Here's why:

THE NEW RCA BONDED CATHODE:

- virtually eliminates peeling of emissive oxide coating
- reduces cathode interface-type impedance effects during life
- reduces grid-to-cathode shorts during life
- improves stability of cathode-to-grid spacing

- improves anode-voltage-per-mil-spacing safety factor in damper diodes
- transmits heat more efficiently and uniformly—thereby providing more uniform cathode-current density

The RCA bonded cathode was first applied with outstanding success in beam power tube types 6DQ6-B and 6JB6 and half-wave vacuum rectifier types 6AU4-GTA and 6AY3. This new development is now being incorporated in a growing number of types where service conditions show a need.

Such RCA developments as the bonded cathode result in reliable components for you to sell and install. Use RCA receiving tubes for all replacements. You have the benefit of continuing tube improvement from the research, design and development facilities of the world's broadest-based electronics company—RCA!

RCA ELECTRONIC COMPONENTS AND DEVICES, HARRISON, N. J.



The Most Trusted Name in Electronics

Circle 61 on literature card

www.americanradiohistory.com

FASTER THAN A SHORT CIRCUIT

LITTELFUSE fuses.

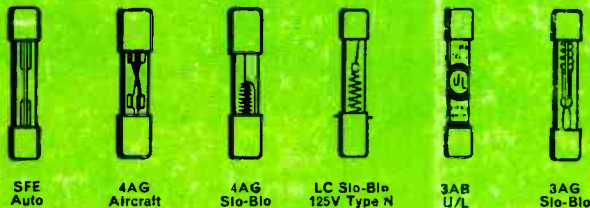

SFE Auto 4AG Aircraft 4AG Sto-Blo LC Sto-Blo 125V Type N 3AB U/L 3AG Sto-Blo

LITTELFUSE fuse posts and holders.

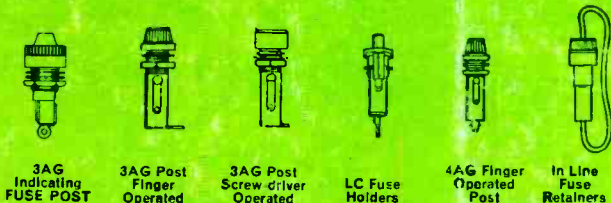

3AG Indicating FUSE POST 3AG Post Finger Operated 3AG Post Screw driver Operated LC Fuse Holders 4AG Finger Operated Post In Line Fuse Retainers

LITTELFUSE fuse mountings.



Through Panel Mounting Screw Terminal Mounting Solder Terminal Mounting Terminal Clip Fuse Clips (earless)

LITTELFUSE Microfuse line.



New Glass Capped Microfuse 1/500 thru 5 amps. @ 125 v. Microfuse panel type holder. Indicating Microfuse Holder voltage ranges 2 1/2-125 v.

As critical circuitry advances in sophistication, precision fuse protection becomes increasingly vital. For 35 years, Littelfuse has enjoyed a fine reputation as a manufacturer of top quality products in the electronic circuit protection field. Each and every Littelfuse product receives the ultimate in precision engineering, design know-how and quality craftsmanship. These are the reasons why the name Littelfuse has become the synonym for quality in the field of electronic circuit protection.

LITTELFUSE

DES PLAINES, ILLINOIS

Circle 62 on literature card