



STANDARD KOLLSMAN BRINGS

Beauty TO UHF CONVERTERS

The Model "A", the only UHF converter you can show and sell with pride. Designer styled in beige and tan to blend with today's decor . . . to harmonize with modern TV cabinet design. Standard waited . . . and tested, analyzed, and re-tested until they could bring you the quality instrument you and your customers have a right to expect from the leading manufacturer of tuners. As a result, you now have a converter which is beautiful, profitable, and dependable.

Contact your Standard representative . . . or write

standard kollsmann INDUSTRIES, INC.

Formerly Standard Coil Products Co., Inc., Melrose Park, Illinois / WORLD'S LARGEST MANUFACTURER OF TELEVISION TUNERS

PERFORMANCE YOU CAN SEE

New low-noise, shielded tuner permits fine tuning for all 70 UHF channels. Functions perfectly with color or black and white sets. Two simple controls: one for VHF, UHF, and "off" . . . the other for channel selection and fine tuning. The "SK" installs in about a minute with just a screwdriver.

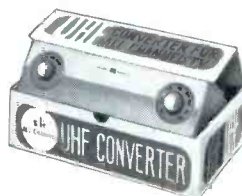

Feature this exciting counter-top display carton

POWER IN PROMOTIONAL SUPPORT

With a first order of 12 units or more, Standard supplies 3 newspaper ad mats . . . 3 radio spot scripts . . . materials for a powerful TV spot . . . 2-color catalog sheets . . . a giant (3' x 6') 2-color window banner . . . a counter card . . . as many pre-printed jumbo post cards as you can use PLUS hard hitting ads in TV Guide.

Circle 1 on literature card

www.americanradiohistory.com

There's a strong downward trend in sizes—and prices—of TV receivers this fall. At least 10 manufacturers now offer 16" sets, and a couple of 11" portables at \$99.95 have found a warm welcome. Over half of all receivers sold have 19" CRT's; an increasing number use simplified circuits that permit lower price tags. New, specially designed sweep-output tubes and "low-drive" CRT's allow sets to operate at B+ voltages of only 135-150 volts without sacrificing performance.

Portable TV's are being imported from Japan at a sharply increasing rate. Approximately half of these are transistorized "tinyvision" sets with screens as small as 4½", but there are also many 16" and 19" portables. Although Japanese receivers will be meeting stiffer competition from small American-made sets, an estimated total of 400,000 will be imported during 1963.

The outlook for color TV is more encouraging than ever, and virtually all U.S. manufacturers are offering color sets in their new lines. We'll bring you fully up to date on this story next month, in our third annual Color TV Special Issue.

VHF-only receivers will be barred from interstate commerce after next spring. Many are still being sold, but convertibility to UHF is becoming an important selling point. More and more sets have 13-position VHF tuners designed so an all-channel UHF continuous tuning attachment can be added; also popular are turret tuners that accept UHF strips.

Highlights of 1964 TV Lines

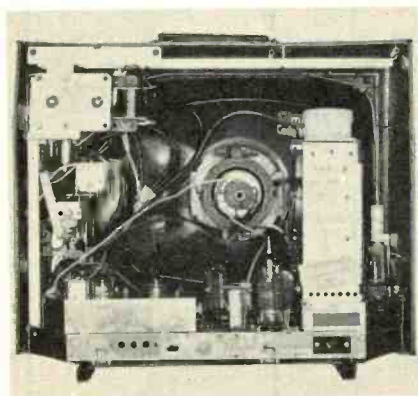

ADMIRAL

Just reaching the market in quantity is an 11" portable. Its chassis is a lightweight frame surrounding the bell of the CRT; most components are on a horizontally mounted printed board at the bottom. Three compactrons help save space: 12AL11 dual pentode (audio detector-output), 17JZ8 triode-pentode (vertical multivibrator-output), and 33-GY7 pentode-diode (horizontal output-damper). Circuits are generally similar to those of larger portables.

The chassis used in 16", 19", and 23" sets for the past several months fall into two basic groups. One includes the 16E4C and the remote-equipped 16G4U (first photo) used in 16" sets, as well as the slightly longer 16A4C and 16K3B series for 19" portables. These sets conform to the newly popular high-efficiency, low B+ design. Basic circuitry is otherwise comparable to that of

last year's portables, except that the 'BU8 combination sync-AGC circuit has been dropped in favor of independently operating sections of a 4BL8 triode-pentode. Several other tubes are being used for the first time: 3EH7 and 3EJ7 frame-grid video IF's, 6JV8 video output-sound IF, 9GV8 triode-pentode vertical multivibrator-output, 10AL11 compactron audio detector-output, and 13GB5 *magnoval*-based horizontal output.

The second group of chassis, all transformer-powered, are found in 19" compact models and 23" sets. As the second photo reveals, they're quite a bit smaller than last year's 23" chassis; however, they're electrically similar to it. The tube lineup has been changed to include 6EH7 and 6EJ7 video IF's, a 6AL11 audio detector-output compactron, a 6JV8 video output-sound IF, and a 110° picture tube instead of a 92° type in 23" sets. Several types of tuners are employed—some with a 6GU5 tetrode RF amplifier, and others with a 6HA5 or 6HK5 neutralized triode.

CURTIS MATHES

The 12 series chassis, used in console and combination sets, is a horizontally-mounted unit 26¼" long (see photo); it has been changed only slightly from last year's 10 series. A 6HS8 sync-AGC-noise limiter tube has displaced the 6KA8 used last year for these functions; in addition, the 6BQ5 tube used as a second video amplifier in many previous chassis is now omitted. The 6HA5 RF amplifier in the latest tuners is similar to the popular 6GK5 neutralized triode, but has been redesigned to improve the noise figure; by the way, it's hardly taller than a 6AL5.

The 23" picture tubes have Owens-Illinois Glass Co.'s new implosion-protection feature, *Kimcode*. No safety

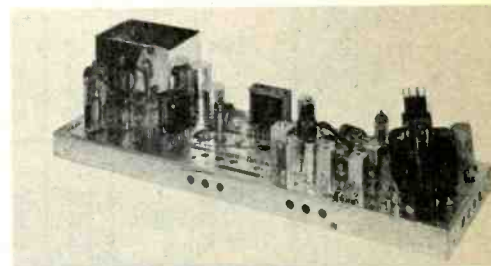

shield of any kind covers the faceplate; instead, a metal pressure band around the outer rim of the tube and a fiberglass sleeve around the bell combine to prevent violent shattering of the glass in case of breakage.

Several 19" models are offered this year. They all have extra-wide cabinets to accommodate the 13 series chassis, which is virtually identical to the 12 series.

DU MONT

At the top of the line is the 120692-A chassis used in *Custom Collector* sets.

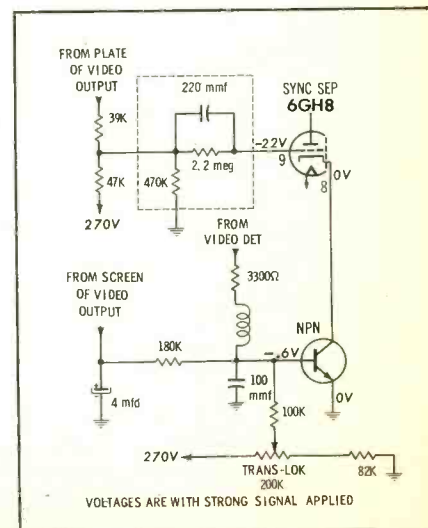

CHASSIS NO.	CRT TYPES	DEG DFL	PRO-TECT	Eg2	PWR XFR	B+ RECT	IF AMP	DC CPL	AGC	NL	HOR AFC	WIDTH CTRL	PROTECTED CIRCUITS LINE	B+	FIL
ADMIRAL C21A1-1E 16E4C, 16G4U, etc. 16A4C, 16K3B, etc. 19A3, 19C3, etc. 21A4, 21A5	11CP4 16BAP4 19CHP4 19AVP4 23CP4	110 114 114 114 110	NA bond sep sep bond	NA hi lo hi hi	 ✓ ✓	one sil one sil one sil FW dbl FW dbl	2 2H 2H 2H 2H	 ✓ ✓	P-C P-C P-C M-C M-C	 M M	CC CC CC CC CC		FR 5.5 ckt brkr ckt brkr ckt brkr ckt brkr		#26 link #26 link
CURTIS MATHES 13 12	19DHP4 23DKP4, 23DLP4 24BCP4	114 92 90	Kim Kim bond	lo lo hi	✓ ✓ 	FW dbl FW dbl	3 3	 	M-C M-C	M M	CT CT	sleeve sleeve	fuse 3.5A fuse 3.5A	fuse 0.5A fuse 0.5A	#26 link #26 link
DU MONT 120677-A, etc. 120692-A	19AVP4 23CP4 23AFP4	114 110 92	sep bond bond	hi hi hi	✓ ✓ ✓	5U4GB 3DG4	3H 3H	 	T-C P-C	T *	CT *	coil pot		fuse 0.45A fuse 3A	#26 link #26 link
EMERSON 120671, -73 120674-A, etc.	16ANP4 19AVP4 23CP4, 27ADP4	114 114 110	bond sep bond	hi ni hi	 ✓ 	one sil 5U4GB	2H 3H	 	T-C T-C	T T	CC CT	coil		fuse 1.2A fuse 0.45A	#26 link
GENERAL ELECTRIC SY LY MY AY	11AP4 19CFP4 19DEP4 23DYP4	110 114 114 110	cap sep sep Kim	hi lo hi hi	 ✓ ✓ ✓	one sil one sil FW dbl FW dbl	2H 3H 3H 3H	 	S-N T-N T-C T-C	 	D D D D	jumper coil coil coil		FR 5 fuse 1.5A fuse 2A fuse 2A	#26 link #26 link #26 link
MAGNAVOX 40 Series 42 Series 44 Series	19BTP4 16AUP4, 19AVP4 23MP4	114 114 114	sep sep sep	hi hi hi	✓ ✓ ✓	one sil HW dbl one sil	3 3 3	 	P-N S-C P-N	 	D S D	coil	fuse 3A		#24 link #24 link
MOTOROLA TS-585 TS-586 TS-584	19CHP4 23CMP4 19CHP4 23DAP4 19XP4, 19BRP4 23ARP4, 23CMP4 23AHP4	114 110 114 95 114 110 92	sep sep sep sep sep sep	lo lo lo lo hi hi	✓ ✓ ✓ 	* one sil 5DJ4	2H 3 3	 	T-N P-N M-N	T T M	CC CC CC	pot jumper coil	ckt brkr ckt brkr ckt brkr		
OLYMPIC Model 6P25 NT NV NB	16AUP4 19XP4 19XP4 23AHP4	114 114 114 92	sep sep sep sep	hi hi hi hi	 ✓ ✓ ✓	HW dbl HW dbl 5U4GB	3 3 3 2H	 	S-C S-N S-N M-C	 M	CC CC CC CC	coil sleeve		fuse 2A ckt brkr ckt brkr ckt brkr	
PACKARD BELL 88-14K, etc. 98D17	19AYP4 23BTP4	114 92	sep bond	hi hi	✓ ✓	5U4GB 3DG4	3 3	 ✓	T-C P-C	T T	CC CC	coil coil	ckt brkr ckt brkr		
PHILCO 14G20 14J25 14J28 14J42, -3, -5 14N30 14N50 14N50A 14N51	16ASP4 19CUP4 19ABP4 19BLP4 19DFP4 23DSP4 23QDP4 23BVP4 23BNP4	114 114 114 114 114 92 92 92 110	bond sep sep sep sep Kim bond bond bond	hi lo hi hi lo lo lo hi hi	 ✓ ✓ ✓ ✓ ✓	one sil one sil HW dbl FW dbl one sil FW dbl FW dbl FW dbl	2H 2H 2H 2H 2H 2H 3H 3H	✓ ✓ ✓ ✓ ✓ ✓ ✓ ✓	T-N T-N T-N P-N T-N T-N P-N P-N	T T T T T T T T	CC CC CC CC 9C CC CC CC	pot pot pot pot pot pot pot pot		FR 5.6 FR 5.6 FR 5.6 FR 5.6 FR 5.6 FR 5.6 FR 5.6 FR 5.6	link link link link
RCA VICTOR KCS146 KCS142 KCS143, -4 KCS147	16AYP4 19AYP4 19AYP4 19AYP4	114 114 114 114	sep sep sep sep	hi hi hi hi	 ✓ 	HW dbl HW dbl HW dbl FW dbl	2H 2H 3H 3H	✓ ✓ ✓ ✓	P-C P-C P-C P-C	 * * *	CT CT CT CT	coil coil coil coil		* * * *	#28 links
SETCHELL-CARLSON 464 400 UX600 U163A	19DCP4 19DCP4 23CP4 23CP4 23CP4	114 114 110 110 110	Kim Kim bond bond bond	hi hi hi hi hi	✓ ✓ ✓ ✓ ✓	FW dbl FW dbl FW dbl FW dbl	2H 2H 2H 2H	 	M N M-N M N M N	M M M M	CC CC CC CC		ckt brkr ckt brkr ckt brkr ckt brkr		

CHASSIS NO.	CRT TYPES	DEG DFL	PROTECT	Eg2	PWR XFR	B+ RECT	IF AMP	DC CPL	AGC	NL	HOR AFC	WIDTH CTRL	PROTECTED CIRCUITS	
													LINE	B+ FIL
SILVERTONE 562. 10000 563. 10100 456. - or 528.60260 456. - or 528.60380, etc. 456. - or 528.60410, etc. 456. - or 528.61220, etc.	250CB4 (10") 16AUP4 19AXP4 19CZP4, 19DAP4 23BQP4 23EWP4 19DAP4 23CBP4	NA 114 114 114 110 114 114 110	NA sep sep bond bond Kim bond bond	NA hi hi hi hi hi hi hi		HW dbl HW dbl one sil HW dbl HW dbl HW dbl HW dbl	3 3 2 2 2 3		S-C S-C S-N S-N S-N M-N		T CC CC CC CC M	coil sleeve sleeve sleeve sleeve	fuse 1.9A ckt 2A ckt brkr ckt brkr ckt brkr ckt brkr	
SYLVANIA 573. -4 575 579	19CVP4 23BGP4 23BGP4, 23BHP4	114 110 110	bond bond bond	lo lo lo		HW dbl 5BC3 3DG4	2H 2H 3H		T-C T-C T-C	M M M	D D D	pot pot pot	ckt brkr ckt brkr ckt brkr	link link
TRAVLER 1188-184 12-118-14 1194-123 10-115-24 10-114-283 10-115-294	16BNP4 16BSP4 19CHP4 23AHP4 23DVP4 27ZP4	114 114 114 92 114 114	sep Kim sep sep Kim sep	lo NA lo hi hi hi		one sil one sil one sil one sil 5U4GB HW dbl	2 2H 2H 2 3 2		S-N T-N T-N S-N M-C S-C		CC CC CC CC S S		FR 4.7 ckt brkr ckt brkr FR 4.7 fuse 3/4A ckt brkr	#26 link
WELLS-GARONER N530, N540 N520, N440 N490 N420, N390 PN45	19CHP4 19XP4 23AWP4 23AHP4 23AHP4	114 114 92 92 92	sep sep sep sep sep	lo hi lo hi hi		one sil HW dbl one sil HW dbl FW dbl	2H 3 2H 3 3		S-N S-C S-N S-C S-C		CC CC CC CC CC	sleeve sleeve sleeve sleeve	FR 4.7 ckt brkr FR 4.7 ckt brkr ckt brkr	
WESTINGHOUSE V-2446 V-2472 V-2443 V-2444	19CMP4 19BWP4 19CMP4 23DCP4	114 114 114 94	sep sep sep sep	lo hi lo lo		one sil HW dbl one sil one sil	2H 3 2H 2H		*		CC CC CC CC	coil	fuse 1 3/4A fuse 2A fuse 1 3/4A fuse 1 3/4A	
ZENITH 14K20 14L30 14L36 15L37 15L33 15L32	16BCP4, 19DBP4 19CRP4 19CXP4 19CXP4 23DNP4, 23ECP4 23EDP4	114 92 114 114 92 92	bond sep sep sep bond bond	lo lo lo lo lo hi		HW dbl FW dbl FW dbl FW dbl FW dbl FW dbl	3 3 3 3 3H 3H		M-C M-C M-C M-C M-C M-C	M M M M M M	CT CT CT CT CT CT	pot sleeve pot pot sleeve sleeve	fuse 2A ckt brkr ckt brkr ckt brkr ckt brkr ckt brkr	#24 link #24 link #24 link #24 link #24 link

ABBREVIATIONS AND SYMBOLS—In any column, CHECK MARK indicates chassis has feature named; ASTERISK means "see text"; NA means data not available at press time. For individual columns—PROTECT (type of implosion protection): sep, separate safety shield; bond, bonded shield (either Corning molded twin-panel or PPG laminated type); Kim, "Kimcode" (see text under Curtis Mathes). Eg2 (accelerating-grid voltage): lo, approximately 50 volts; hi, 150 to 500 volts. B+ RECT: one sil, one silicon rectifier; HW dbl, half-wave voltage doubler using two silicon rectifiers; FW dbl, full-wave silicon doubler. IF AMP: Figure indicates number of stages; "H" indicates use of two or more tubes having substantially higher gain than 6CB6. DC CPL means set has DC path or DC restoration in video drive circuit of CRT. AGC: First letter M, multipurpose tube ('HS8, 'BU8, or similar); P, pentode keyer; T, triode keyer; S, simple (no tube). Second letter C, has AGC potentiometer; N, no AGC adjustment. NL (noise limiter): M, function of multipurpose tube (controlling sine-wave or "Synchroguide" oscillator); S, two selenium diodes in series; D, dual diode sections of tube. PROTECTED CIRCUITS: figure following "fuse" is rating in amps; "FR" indicates fusible resistor and is followed by rating in ohms; "link" means short wire, of gauge indicated (usually #26).

This hand-wired unit, which mounts vertically on one side of the cabinet, is a modification of last year's 120612 and 120629 series—with several important changes. Most interesting of these is the replacement of a 6HS8 AGC-sync tube by a 6GH8, supplemented by a transistorized noise limiter (see schematic). The NPN transistor normally conducts and furnishes a low-resistance ground connection for the sync-separator cathode and the video detector load. But a strong negative noise pulse in the detector-output signal will interrupt the conduction of the transistor, thus preventing the pulse from passing through the sync circuit. A TRANS-LOK control sets the bias on the transistor for optimum operation.

Elsewhere in this new chassis, a sine-

wave horizontal oscillator (using another 6GH8) supersedes the former 6CG7 multivibrator, although a 6AL5 remains in use as a horizontal AFC phase detector. A 6DT6 sound detector takes the place of a ratio detector, and a 6GW8/ECL86 triode-pentode operates in a two-stage audio amplifier. All models include an automatic brightness-contrast control circuit.

Other DuMont sets, both 19" and 23", have vertical chassis similar to the present Emerson types. The 120677-A and higher-numbered chassis are related to the Emerson 120674; also used is the 120622-A, which is like the Emerson 120619 series. The line includes a few 27" receivers as holdovers from last year.

All 23" and 27" sets, but not 19", can be converted to UHF by adding

either individual channel strips or a UHF Tuner Field Assembly (an all-channel tuner with mounting plate).

EMERSON

Completely new in the '64 lineup is a 16" portable using the 120671-series chassis shown in the photo. Like many other lightweight sets introduced this year, it has sweep output tubes specially designed for low B+ operation—the 13GB5/XL500 horizontal output and 8CW5/XL86 vertical output. Other unusual tubes are the 16AQ3/XY88 damper, 6K11 or 6Q11 compactron as a sync separator-keyed AGC-noise inverter, and a 5GH8 or 4BL8 in a sine-wave horizontal oscillator whose frequency is directly controlled by dual selenium diodes. The PICTURE OPTIMIZER service control in this set is not

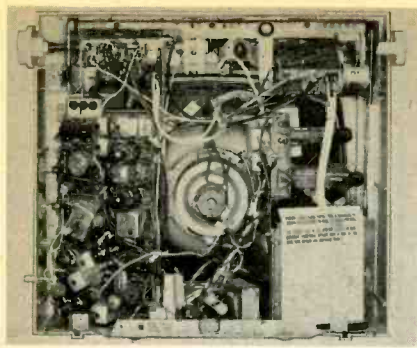

a video bandwidth control, but a cathode-bias adjustment for the AGC keying tube.

The 19", 23", and 27" sets all have the same basic chassis design, although various chassis numbers are employed. The physical layout is identical to that of the 120619 series that was the mainstay of the '63 line—a vertical chassis with a printed wiring board on the top half and a solid metal pan for the bottom half. A couple of notable changes have been made in the circuitry; the horizontal multivibrator has been replaced with a sine-wave oscillator, and several other stages have been reshuffled as follows: Instead of having a 6BU8 sync-AGC tube and a 6AU6 sound IF, the new chassis has a 6GH8 sound IF-sync separator tube and a 12AZ7A (dual triode) AGC-noise limiter tube. The function of the familiar LOCAL-DISTANCE control has been divided between two new controls—the PICTURE OPTIMIZER (an AGC control) and the NOISE LOK (which sets the bias on the noise limiter).

GENERAL ELECTRIC

One of this year's most talked-about sets is G-E's new 11" *Personal Portable*, a 1234-lb. receiver with 60 sq. in. of viewing area. As shown in the photo, its SY "chassis" consists mostly of two printed boards held together by light braces; there's no metal chassis to add weight. CRT anode voltage is 11 kv. All circuit tubes are compactrons except the tuner tubes and the 1X2B high-voltage rectifier.

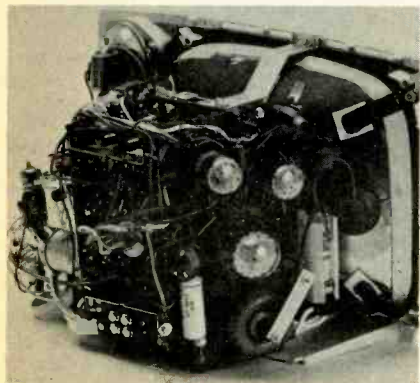

One, the 33GT7, is a combined horizontal output tube and damper. Others are: 11AR11, first and second video IF; 15BD11, video output-sync separator-sound IF; 17BF11, audio quadrature detector and output; 17JZ8, vertical multivibrator-output; and 8B10, hori-

zontal AFC-oscillator. Models are available with a built-in UHF tuner having a transistorized oscillator.

The 16" *Escort* portable continues to use the QX chassis introduced a year ago, and the next two chassis in the line are revisions of '63 types. The 19" *Celebrity* and *Century* portables now have Chassis LY instead of LX; although still transformer-powered, the new version has only one silicon rectifier, and various circuits have been modified for low B+ operation. Keyed AGC has also been added.

Substitutions in the LY tube lineup have been as follows: 6JN8 third IF-keyed AGC, for 6CB6 third IF; 6BD11 video amplifier-sound IF-sync separator, for 6AS11; 6BF11 audio detector-output, for 6G11; 6JZ8 vertical multivibrator-output, for 6FJ7; 6HB5 horizontal output, for 6GE5; 6BJ3 damper, for 6W4GTA; and 1AD2 HV rectifier, for 1K3.

The MY chassis used in the rest of the 19" sets has been changed relatively little from the '63 MX. However, some tube changes have been made: third IF, from 6EW6 to 6CB6; vertical multivibrator-output, from 6DN7 to 6FY7; horizontal oscillator, from 6CG7 to 6B10; picture tube, from 19CKP4 to 19DEP4.

All 23" sets contain the newly designed AY chassis, which is not very different electrically from the MY, but which has a wide, horizontal layout to take advantage of the room available in a large cabinet. The tube complement shows a couple of variations from that of the MY: a 6JN8 third IF-keyed AGC, and a 6T10 audio detector-output. The tuner uses a 6HA5 RF amplifier and another new type, the 6KZ8, as a mixer-oscillator. An automatic brightness-control circuit, equipped with an ABC DEFEAT switch, is found in some models.

MAGNAVOX

Nearly identical circuits are found in the 40 and 44 series chassis, which are now beginning to appear in 19" and 23" sets respectively. These chassis are transformer-powered, even though only one silicon rectifier is used to develop B+; a slight step-up in the transformer results in 150 volts on the B+ line. A new, lower-voltage sweep system includes a toroid yoke driven by a 6GB5 horizontal output and 6CW5 vertical output tube. Most of the remaining circuits are consistent with recent Magnavox design practice, except that the two diode sections of a 6BJ8 tube have replaced a series-type dual selenium diode in the horizontal AFC stage. The triode portion of the 6BJ8 functions as the first half of the vertical multivibrator.

Videomatic circuitry, including the *Magnalux* automatic brightness-contrast system and the *Phantom* wireless remote control, continues to be available in some models. The 36 series (23"-24"-27") and 38 series (19") chassis have been carried over into current production. Magnavox is now the only manufacturer



offering a wide choice of 24" models, including the one shown in the photo—an example of the Italian Provincial styling that is gaining favor this year.

The letter C preceding the chassis number in some VHF sets indicates provisions for easy conversion to UHF by adding individual channel strips.

A new 16" *Vacationer* portable and some lightweight 19" sets utilize a transformerless chassis, the 42 series, manu-

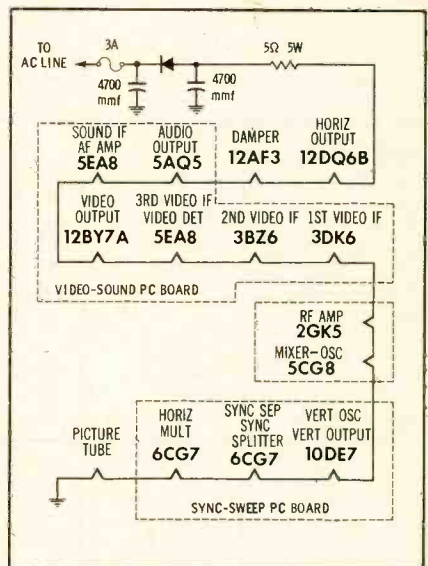

factured for Magnavox in Japan by Nippon Electric Co. Its most unusual feature (shown in schematic) is a silicon rectifier inserted in the series filament line to supply fluctuating DC voltage to all tube filaments. Other circuits unlike those of other present Magnavox sets are the vertical blocking oscillator (one-half of a 10DE7), a triode section of a 5EA8 operating as a video detector-AGC rectifier, and a ratio detector with two germanium diodes.

All of the latest chassis are vertically mounted and have either two or three printed wiring boards. The U-shaped design that characterizes the 35 and 36 series is continued in the 44 series.

MOTOROLA

Only two basic chassis will be in production this Fall; each will be used in both 19" and 23" models. The *Power M* chassis (TS-586) is basically the same as the TS-449 and -578 low B+ types first introduced a year and a half ago; however, changes have been made in several circuits. A three-stage video IF strip using 3BZ6's replaces a two-stage frame-grid IF; the video output tube is now a 16GK6; and the noise-inverter circuit has been changed to the form shown in the schematic. Some models

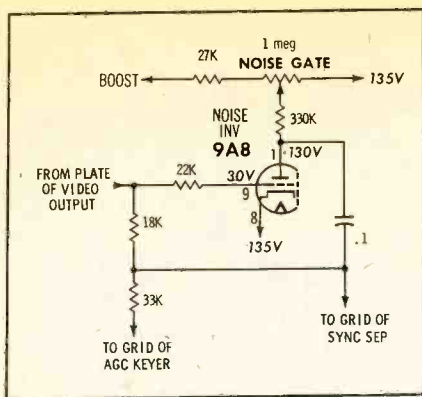

are available with built-in UHF tuners, and field conversion of VHF-only sets is possible by adding a UHF tuner and a two-stage UHF-IF amplifier (sub-chassis TUA-1) that completely bypasses the regular VHF tuner for UHF operation.

The transformer-powered *Super Golden M* chassis (TS-584) has been carried over from the '63 line with only a few modifications. A current model is shown in the photo; note the cabinet-mounted CRT. Both 92° and 110° picture tubes will be used in various 23" models, just as before; and a new bonded-shield 19" tube will be included in the bulk of '64 production. The width control is now a coil in series with the low side of the yoke, rather than a pot in the horizontal-output screen circuit. A new 13-position VHF switch tuner, using a 6HA5 RF amplifier and a 6GJ7 mixer-oscillator, includes UHF-IF ("channel 1") circuitry in readiness for field conversion to all-channel operation.

wiring utilizes cone-type dip-soldered connections. Provisions are made for easy conversion to all-channel UHF. In general, the circuits are almost the same as in last year's deluxe MB chassis.



Many of the 23" receivers are combination models, such as the *Napoli* in the photo, and the TV sound is fed through the stereo amplifier. Therefore, the standard TV chassis has no audio output stage, and TV-only models are provided with a small audio subchassis having a single 6BQ5 tube.

The 19" NV chassis is a slightly modified version of the older MV. This year, the sound IF stage has been omitted, freeing the triode section of a 6GN8 for use as a sync separator—in place of the formerly used 6AV6. Another 19" chassis, the NT, is equivalent to the NV minus the power transformer.

The imported Chassis 10119 has been carried over into the '64 line; in addition, a 16" portable TV set is being made for Olympic in Japan. This model has a vertical chassis with three small PC boards; the tubes and circuits are all familiar types.



deluxe 98D17 chassis. This unit differs from last year's 98D16C in several minor details. The most noticeable change is a relocation of the PICTURE FIDELITY (video frequency response) control from the grid of the video output stage to the grid of the CRT.

To enhance the furniture styling of *Award* receivers, a wood-grain finish is now applied to the control panel and to the frame around the CRT screen—as illustrated by the "tea cart" model in the photo.

Complete conversion kits are available for adding a wireless remote control or an all-channel UHF tuner to any '64 set.

PHILCO

A great variety of chassis types and cabinet styles are offered, including several new items and several others carried over from last year.

A chassis with low B+, introduced last winter in the 16" *Courier* portable, is now used with three different sizes of picture tubes. The 16" version (Chassis 14G20) is practically the same as the original 13G20 described in September, 1963 *Previews of New Sets*. Only slight differences are noted in the 14J25 chassis, found in a new *Starlite* group of 19" portables with small rectangular cabinets. (Where the 16" set has a 6AQ5 audio output tube, the 19" has a 10JY8 triode-pentode, and the triode section is used as a noise inverter.) The third version of the low B+ chassis is the 14N30 used in the *Special 90* (lowest-priced) series of 23" sets. Although the circuits are the same as in the 14J25, the 23" chassis has the high-voltage cage and various heavy components spread out on a large horizontal mounting plate, rather than being clustered together as they are in the smaller sets.

The *Town & Country* and *Town House* 19" sets are continued almost unchanged from last year. Present chassis numbers are 14J28 for the briefcase-styled *Town & Country*, and 14J42 through -5 for the deluxe *Town House* series.

The bulk of the 23" models are in the *Super 90* group, with a 92° picture tube. Individual models may use either the 14N50 or 14N50A chassis. The latter, a modification of the 13N50 from last year, is being "phased out" in favor of the newly introduced 14N50. This chassis has the same shape as the 14J42, but includes extensive circuit revisions. Like other recent Philcos, it has

PACKARD BELL

Current models of 19" *Astronaut* and 23" *Custom* receivers contain 88-14 series chassis, practically unchanged from their

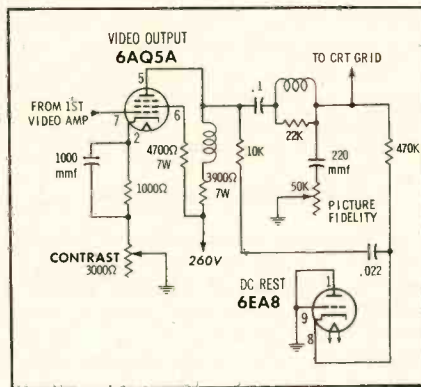

counterparts in last year's line (except for a different 19" picture tube). Several special features are still available, including wireless *Roto/Remote* control, the *Computer Dial* illuminated channel indicator, and a sleep-switch timer. One unusual new 19" set, the *Little Theater*, can be either hung on the wall or used as a table model; sliding tambour doors cover the face of the wood cabinet when the set is not in use.

Most of the black-and-white models introduced during the last several months are *Award* series sets equipped with the

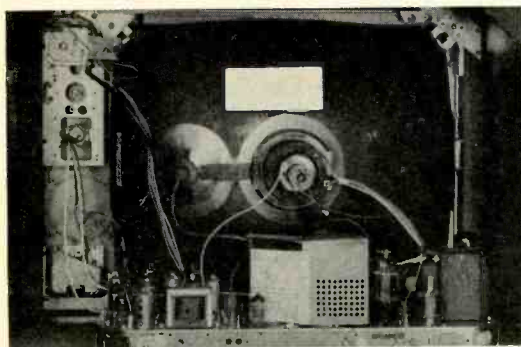

Another chassis, the TS-585, was produced during the latter part of the '63 model year. It has a power transformer that feeds an unusual full-wave silicon rectifier—the circuit configuration is like that of a 5U4 setup, but the B+ output is only 185 volts. All output tubes are unfamiliar types: 6CW5 audio, 6CW5 vertical, 6HA6 video, and 6HD5 (companion) horizontal.

An all-transistor 19" portable set is still available, now bearing the chassis number TS-453.

OLYMPIC

All 23" receivers have one standard chassis, the NB, with an entirely new style of construction. The unit is long, narrow, and horizontally mounted; a small PC board houses the two-stage, frame-grid IF strip, and the rest of the

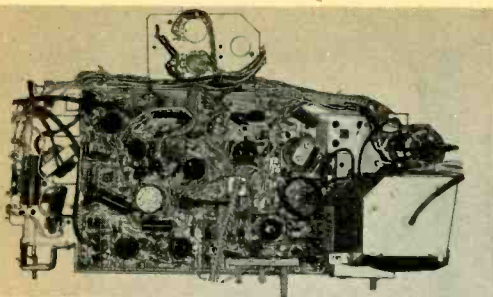

a varistor circuit for automatic regulation of width and high voltage, but a new configuration has been devised for this circuit (see schematic). The tube complement includes four compactrons: 6GY5 horizontal output, 6BE3 damper, and two 6JZ8 triode-pentodes (audio output-keyed AGC and vertical multivibrator-output). The video output-sync separator tube is a new 9-pin type, the 6LB8.

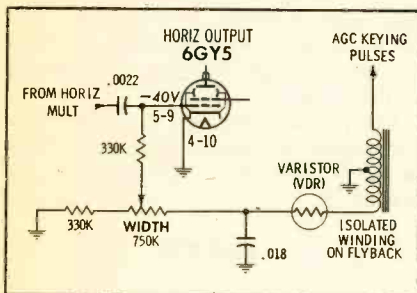

Custom 23" sets with 110° picture tubes have the 14N51 chassis—another one that shows few changes since last year.

RCA VICTOR

A bevy of new portables are on the scene, and prominent among them are the 16" *Petite* and *Debutante* models. The lightweight, vertically mounted KCS146 chassis in these sets is constructed somewhat differently from the 19" units, and has only one PC board. Several tubes are unfamiliar types: 4JD6 and 4JC6 frame-grid IF's, 11KV8 video output-sound IF (with extremely high-gain video section), 12FX5 audio output, 13GF7 novar vertical sweep, and 17JB6 novar horizontal output. This tube has an external suppressor-grid connection to allow installing a special circuit (shown in schematic) in UHF-VHF models. A positive voltage applied to the suppressor eliminates internal oscillations that might otherwise be radiated by the tube and picked up by the UHF tuner, causing snivet-like interference in the picture. This suppression circuit is used in UHF versions

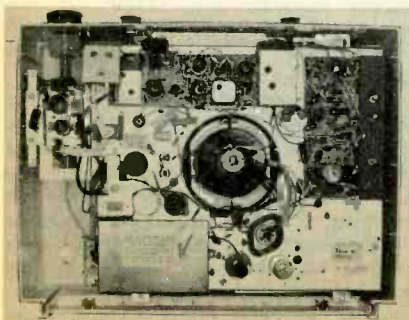

of all '64 portables; in addition, to suppress UHF oscillation from a different source, a 6HZ6 audio detector is substituted for the regular 6GX6.

The simplest 19" portables use Chassis KCS142. As the photo indicates, it resembles last year's KCS141 in appearance; on the other hand, the circuits correspond to those of the KCS146. (There's one exception: A 6KA8 AGC-sync tube is used instead of a 6GH8.)

Both the KCS146 and -2 have neutralized-triode tuners with a new 5KE8 mixer-oscillator; all other sets feature novistor tuners. In every case, a 13-position tuner is used, to facilitate field conversion to UHF.

Two other transformerless portables, the KCS143 and -4, are identical except that the latter uses a more elaborate version of the 6KA8 AGC-sync-noise limiter circuit, including a NOISE STABILITY control. These sets have a higher-gain video IF strip, but a lower-gain video amplifier, than the KCS142.

A deluxe, transformer-powered 19" chassis, the KCS147, is a close relative of the KCS141 from '63. In fact, the KCS141 itself has been kept in the line, unchanged except for adding the 'JB6 horizontal suppression circuit and a new type of CRT.

All chassis use a special .4-amp chemical fuse to protect the B+ circuit; in addition, transformerless models have a 5-ohm fuse resistor, and transformer-equipped types have a 2.5-amp line fuse

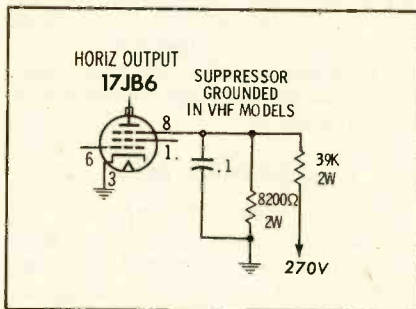

plus two #28 filament-fuse links.

No 23" sets are listed in the chart because all models use the KCS136 *New Vista Deluxe* chassis, now going into its third year of production.

SETCHELL-CARLSON

A departure from previous designs, the unit pictured here (Chassis 400) is used in a number of 23" sets and 19" table models. The long, narrow horizontal section includes the sync, AGC, sweep, and power-supply circuits; signal circuitry is on the vertically-mounted square section. This is the only Setchell-Carlson chassis to use a 6DT6 quadrature sound detector in place of the customary ratio detector. In most other respects, the 400's circuits are like those of the 19" Chassis 464—and those, in turn, are very close to the circuits of the 463 used in last year's portables. Both of the new chassis have 6HJ5 horizontal output and 6AY3 damper tubes; furthermore, a 6HS8 multipurpose tube has taken over the sync and AGC functions previously handled by a 6CS6 and a 6CL8A triode section.

The two larger 23" chassis are both

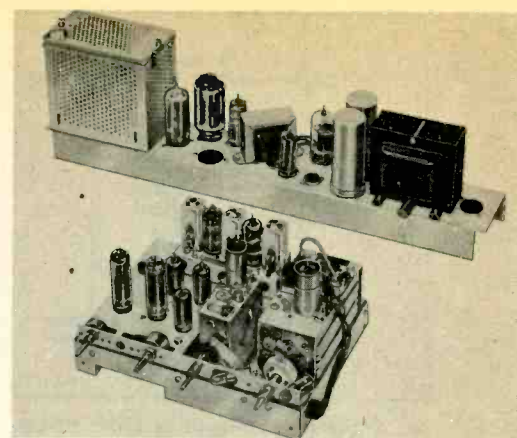

fully *Unit-ized* types with seven basic plug-in TV-circuit subchassis; the TV circuitry is nearly the same for both. (In general, it's similar to that of Chassis 400, but with conventional horizontal sweep tubes and ratio detector.) The UX600 is a vertically-mounted unit, while the *Custom* U163A is a larger, horizontally mounted chassis with expanded provisions for plugging in accessories—including an AM-FM tuner, a multiplex stereo adapter, and matched push-pull audio amplifiers for stereo.

This year's sets all have neutralized-triode VHF tuners, and are set up to accept a plug-in all-channel UHF tuner.

SILVERTONE

A 10" set with a *Sears* label is being imported from Japan. Most components are mounted on a horizontal chassis that covers the bottom of the cabinet; the circuits include a cascade tuner, three-stage 21-mc IF, ratio detector, and vertical blocking oscillator. The non-amplified AGC system uses the horizontal-output and sync-separator grid circuits as auxiliary bias sources (note the AGC control and LOCAL-DISTANT jumper in the schematic). Another *Sears*-branded import, a 16" model, has a vertical chassis with generally orthodox circuitry.

In the regular Silvertone line, one series of 19" portables has an all-new chassis with low B+, an 8JV8 video output-sound IF tube, and three novar tubes: 15KY8 vertical multivibrator-output, 22JG6 horizontal output, and 17BS3 damper. The chassis is shaped to fit the contour of a thin cabinet.

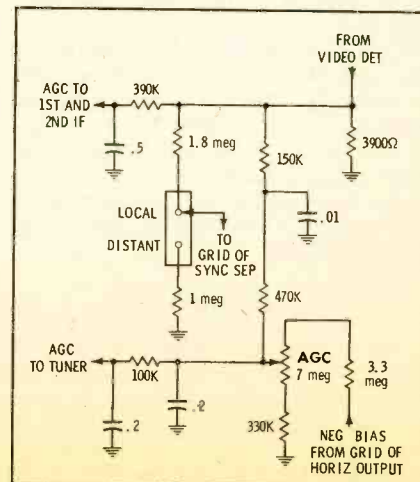

Other 19" and 23" sets have vertical chassis like the one pictured in last year's *Highlights*, with tubes facing forward. Few circuit changes have been made, although 8JV8 video tubes are displacing 8AW8A's, and a novar 13GF7 vertical sweep tube is now employed instead of an octal 8EM7.

SYLVANIA

The *Skylark* portables introduced last spring, with their distinctive *Curtain-*

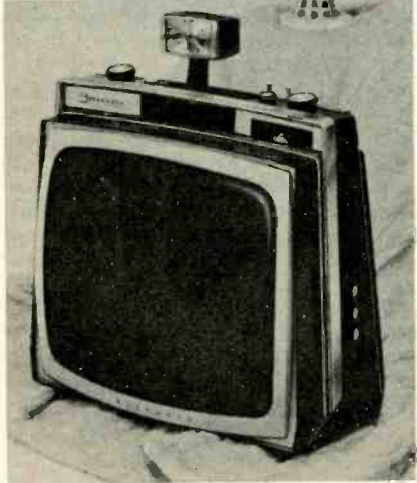

Timer clock, were the herald of a completely revamped TV line. These models and the '64 *Suburbanite V* portables all contain a new, horizontal *Power Stream* chassis (571, -3, or -4). A large group of moderately priced 23" sets, called the *Dynamic America* series, use the *Deluxe Power Stream* (Chassis 575)—identical to the 19" chassis, with a power transformer added. The larger horizontal chassis that was standard in last year's 23" sets has been upgraded and modernized; now known as the *Power Bonus* (Chassis 579), it is found in fine-furniture *Custom Deluxe* receivers.

The 19" chassis has frame-grid tubes in all picture-signal stages: 3GW5 or 3GK5 RF amplifier, 5HG8 mixer, 4EH7 and 4EJ7 IF's, and 10KU8 (pentode-dual diode) video amplifier-horizontal AFC. The horizontal output and damper are novar types, the 17GJ5 and 17AY3. Also new are the 5KD8 AGC keyer-sound IF and the 13FD7 vertical sweep tube. Sylvania, who was one of the last remaining users of ratio detectors in TV until this year, has changed over to a 4DT6 quadrature detector. A factory-adjusted horizontal linearity coil is in-

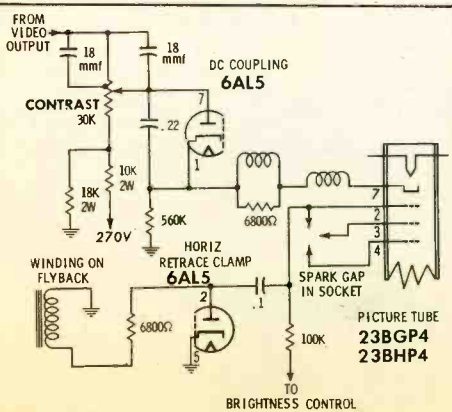

cluded in the plate circuit, of the damper.

The *Deluxe Power Stream* includes 6-volt versions of all the tubes just mentioned, plus a novar 5BC3 rectifier.

All sets with the *Power Bonus* chassis have *HaloLight* surrounding the picture. The audio detector has been changed to a 6DT6; a series-type DC restorer and a horizontal retrace clamp diode (see schematic) have been added to the video circuitry; and new 6KU8, 6KD8, 6GJ5, and 6AY3 tubes have superseded the former 6ET7, 6BR8A, 6DQ6B, and 6AX4GTB.

TRAVLER

Now exclusively a private-label manufacturer, Travler is producing many different sizes and types of TV sets; those listed in the chart are typical of the current line. The 23" and 27" sets are much the same as their '63 counterparts; on the other hand, the portables have been extensively changed, with several new chassis designed to operate at low B+.

The 12-118-14, used in some 16" sets, is the first TraVler-made set to have a printed-circuit board. Its 450-ma series-string tubes include the following new types: 21GY5 horizontal output, 17BE3 damper, 10CW5 vertical output, and 10GK6 video output. Many other portables have a fundamentally similar design, but are hand-wired and use 600-ma tubes. The vertical, horizontal, and

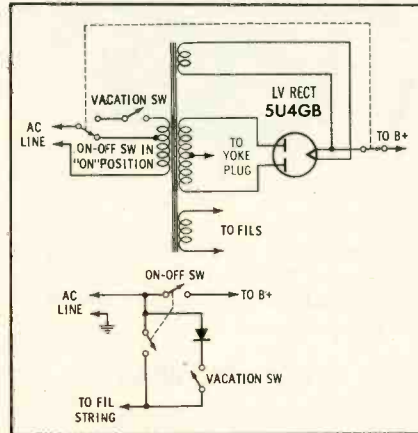

video output tubes are an 8CW5, a 21HJ5 compactron, and an 8BQ5, respectively. The sound IF stage now uses a pentode—a 3AV6 in models with simple AGC, or half of a 4BL8 in models that use the other half of this tube as an AGC keyer.

WELLS-GARDNER

The newest sets from this private-

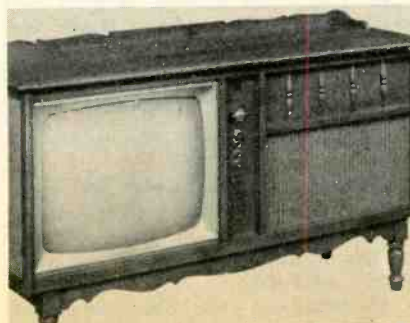

label manufacturer show increasingly standardized design, although the current roster shows a long list of different chassis numbers. All 19" chassis are horizontal (see photo), with printed wiring in all except the N530 and N540 series. The 23" chassis are all vertical, side-mounted units having two PC boards. No sets have keyed AGC, sound IF amplifiers, or extra sync stages. Novar horizontal output and damper tubes, the 6- /12GT5 and 6- /12AY3, are used throughout the line. Chassis with low B+ have an 8CW5 vertical output tube; other chassis are equipped with an 'EM5 or 'DE7.

In sets that have DC-coupled video

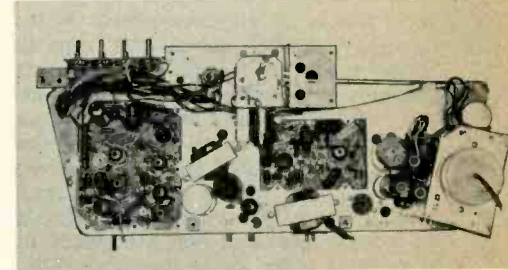

circuitry, automatic brightness-contrast control is optionally available. A light-dependent resistor is simply added in parallel with the contrast control in the cathode circuit of the video output tube.

A UHF tuner kit is supplied for field conversion of any set to all-channel operation.

WESTINGHOUSE

The *swing-down* vertical chassis described in *Highlights* last year is still in the current line; both the series-string V-2435 and the transformer-powered V-2436 are used in various 19" *Trendsetter* compact sets and 23" receivers. Some of last year's portables with the V-2437 chassis have also been carried over.

Practically a twin to the V-2437 is the new *swing-around* Chassis V-2472 (shown in servicing position). One novel feature in the latter chassis is horizontal retrace blanking, with pulses

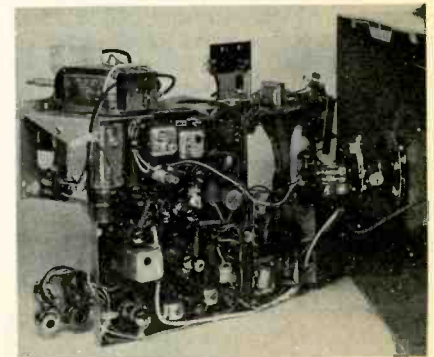

coupled from an isolated winding on the flyback through a neon bulb to the control grid of the CRT.

The V-2438 (low B+) chassis from last year's line has been superseded by three new chassis that use the same tube complement. The V-2443 (for 19" *Trendsetters*) and V-2444 (for 23" sets) both have the *swing-down* type of chassis construction, while the V-2446 (for 19" portables) uses the smaller *swing-*

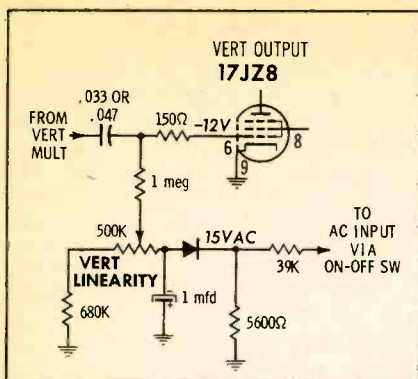

around design. An especially interesting new feature of all three chassis is the auxiliary rectifier circuit that supplies negative bias to the grid of the vertical output tube. Any fluctuation in line voltage results in a bias change that tends to stabilize the vertical sweep. (In last year's V-2438, the bias was derived from the grid voltage of the horizontal output tube.) These chassis also provide a trimmer capacitor for adjustment of the keying pulse fed to the triode AGC tube. Other sets do not include this feature, and the keying tube is variously a pentode or a tetrode.

Wireless remote control, *Instant On*, and *Mobil Sound* accessory features are again available on many models of all styles.

ZENITH

Present models have one or two fewer tubes than their predecessors, because silicon voltage doublers have replaced vacuum-tube rectifiers, and multipurpose compactrons have been introduced in a few circuits. One completely new chassis has been brought out since last fall—the transformerless, lightweight 14K20 (PHOTOFACT Folder 638-16-S). First used in 16" portables, it's now in 19" *Jelliner* models, too.

All '64 sets have a self-adjusting noise-limiter circuit, with a voltage-dependent resistor in place of the FRINGE LOCK control. A PEAK PICTURE control (video frequency response) is now included in all chassis except 14K20. Even the 23" sets are using compactron or novar vertical and horizontal output tubes and a novar damper. In the 19" category, the audio section of the 14L30 includes a 6J10 compactron that does the same job as a 6BN6 and a 6AQ5 combined. The 15L37 has a 6BA11 compactron with four functions—AGC keyer, sync separator, noise limiter, and vertical discharge—the equivalent of a 6HS8 plus a triode section of a 6EM7.

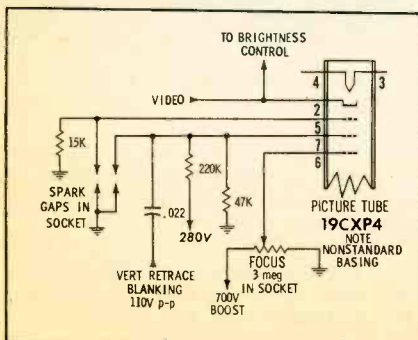

(The vertical output tube is a 6GK6.) The CRT socket in this chassis houses a focus control (operated by rotating a ring on the socket), and also contains spark gaps to protect the control and accelerating grids.

As usual, there are two 23" chassis. The deluxe 15L32 has slightly greater high voltage than the standard 15L33, uses high accelerating-grid voltage on the CRT, and is equipped with the new *Super Gold Video Guard* tuner pictured here. This turret tuner, also available in some sets with the 15L37 chassis, will accept as many as 12 UHF channel strips in place of VHF strips. Some versions of this and other '64 tuners can be converted to all-channel UHF by installing a continuous tuner and connecting it to the VHF tuner via an *Addible Switch Assembly*.

The midyear models introduced last winter were more similar to last fall's

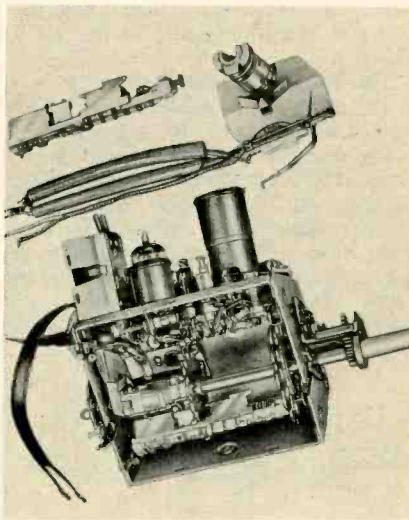

models than to the new '64 line. Chassis numbers in the winter series were 16K30, 16K36, and 15K37 for 19" sets; 16K32, 16K33, 16K34, and 16K38QS for 23" sets.

OTHER U.S. BRANDS

Andrea manufactures both 19" and 23" sets; current models use the VTT-series chassis. One 23" receiver, the "Satellite," is designed for custom built-in installation.

The **deForest** line includes consoles and combinations with a "pull-out capsule" TV chassis mounted on a sliding rack; all connections are automatically unplugged when the chassis is removed.

Muntz is continuing to produce its TV line without major changes.

TV kits—color as well as black and white—are available from **Heath and Transvision**.

FROM CANADA

Canadian Marconi is offering five different 23" models.

Clairtone black-and-white and color "Theaters" (TV-stereo combinations) are each available in three different cabinet styles. Stereo circuits are completely solid-state.

All black-and-white **Electrohome** sets are now equipped with a "Centurion"

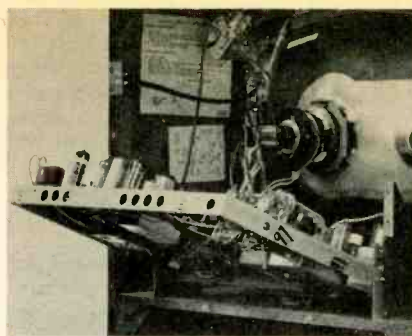

chassis, featuring pivot-down design. Four different versions, all hand-wired, are now in production. Sets obtainable in the U.S. include 19" portables and table models, 23" consoles and combinations, and color receivers.

Selected combination sets and one console make up the **Fleetwood** line for the U.S. Two different hand-wired chassis have 21 and 25 tubes, respectively.

Sparton has four TV-stereo combinations (23N5 through -8), several TV consoles (23N1, -2; 23M2, -8, and -9), and three 19" compacts in the 19N1 and -2 series.

FROM JAPAN

Arvin is importing one 16" model . . . **Channel Master** has two "Bring-Along" sets, a transistorized 8" (Model 6565) and a 16" (Model 6570) . . .

Delmonico has an extensive line, including 4½" and 5½" transistorized portables, 8", 9", 16", and 19" portables, and 23" stereo theaters . . .

A **Hitachi** receiver imported by The Sampson Co. is the Model STX-880, a 16" portable with swing-out chassis . . .

Panasonic by Matsushita offers a "Mitey 9" transistorized set, plus 9" and 14" portables with tubes . . .

Peerless Telerad, Inc. has a 16" model in a wood cabinet with legs . . .

Raleigh 8" sets, with tubes, are imported by Kaysons International, Ltd. . . .

Sharp receivers, made by Hayakawa, include 6" and 8½" transistor portables, two differently-shaped 16" portables, and a 19" compact model . . .

Sony is concentrating on "tinyvision" with its 5" Model 5-303W "Micro-TV" and 8" Model 8-301W; a UHF converter, Model VUC-4W, fits both sets . . .

Star-Lite has a transistorized 5" receiver and a 16" set mounted on legs . . .

Symphonic is importing two 16" portables, Models 10P16 and 20P16, made by Nippon Electric . . .

Tokai 8" portables are tube-equipped . . .

The **Westrex** "Westar" is another 8" set with tubes. ▲

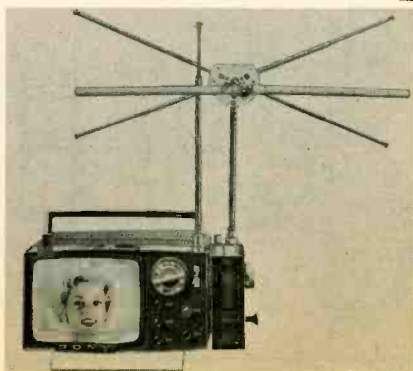

Prices effective January 1, 1963

Tarzian offers
**FAST, DEPENDABLE
TUNER REPAIR
SERVICE (ALL
MAKES)**

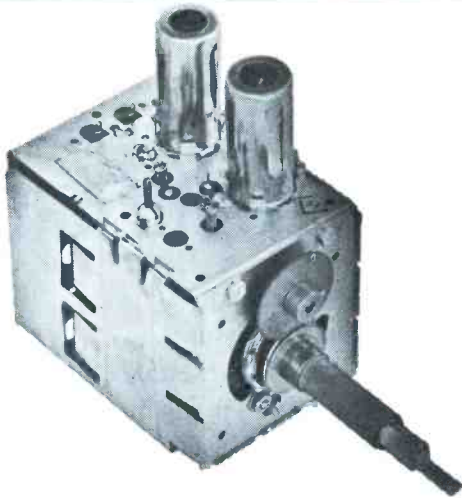

It just makes sense that a manufacturer of tuners should be better-qualified, better-equipped to offer the most dependable tuner repair and overhaul service.

Sarkes Tarzian, Inc. pioneer in the tuner business, maintains two complete, well-equipped Factory Service Centers—assisted by Engineering personnel—and staffed by specialized technicians who handle **ONLY** tuner repairs on **ALL** makes and models.

Tarzian-made tuners received one day will be repaired and shipped out the next. Allow a little more time for service on other than Tarzian-made tuners.

Tarzian offers a 12-month guarantee against defective workmanship and parts failure due to normal usage. And, compare our cost of \$9.50 and \$15 for UV combinations. There is absolutely no additional, hidden charge, for **ANY** parts except tubes. You pay shipping costs. Replacements on tuners beyond practical repair are available at low cost.

Ⓢ Tarzian-made tuners are identified by this stamping. When inquiring about service on other tuners, always give TV make, chassis and Model number. All tuners repaired on approved, open accounts. Check with your local distributor for Sarkes Tarzian replacement tuners, replacement parts, or repair service.



SARKES TARZIAN, INC.

Bloomington, Indiana

MANUFACTURERS OF TUNERS . . . SEMICONDUCTORS . . . AIR TRIMMERS . . . FM RADIOS . . . AM/FM RADIOS . . . AUDIO TAPE . . . BROADCAST EQUIPMENT

**ONLY
\$9.50
INCLUDING**

**ALL PARTS
(except tubes)
and LABOR**

**24-HOUR SERVICE
1-YEAR WARRANTY**

**TWO SERVICE CENTERS
TO SERVE YOU BETTER**

**See your distributor, or use the
address nearest you for fast fac-
tory repair service**

537 South Walnut St.
Bloomington, Indiana
Tel: 332-6055

10654 Magnolia Blvd.
North Hollywood, Calif.
Tel: 769-2720

Circle 2 on literature card

October, 1963/PF REPORTER 9

WHY

risk your reputation with "just-as-good" capacitors?

When you pay little or no attention to quality in tubular replacement capacitors, you leave yourself wide open for criticism of your work . . . you risk your reputation . . . you stand to lose customers. It just doesn't pay to take a chance on capacitors with unknown or debatable performance records when it's so easy to get guaranteed dependable tubulars from your Sprague distributor!

There's no "maybe" with these 2 great SPRAGUE DIFILM® TUBULARS!

The ultimate in tubular capacitor construction. Dual dielectric . . . polyester film and special capacitor tissue . . . combines the best features of both. Impregnated with HCX®, an exclusive Sprague synthetic hydrocarbon material which fills every void in the paper, every pinhole in the plastic film *before it solidifies*, resulting in a rock-hard capacitor section . . . there's no oil to leak, no wax to drip.



DIFILM® BLACK BEAUTY®
Molded Tubular Capacitors

The world's most humidity-resistant molded capacitors. Tough, protective outer case of non-flammable molded phenolic . . . cannot be damaged in handling or installation. Designed for 105°C operation with *no voltage derating* . . . will withstand the hottest temperatures to be found in any TV or radio set, even in the most humid climates.



DIFILM® ORANGE DROP®
Dipped Tubular Capacitors

A "must" for applications where only radial-lead capacitors will fit . . . the perfect replacement for dipped capacitors now used in many leading TV sets. Double-dipped in rugged epoxy resin for positive protection against extreme heat and humidity. No other dipped tubular capacitor can match Sprague Orange Drops!

For complete listings, get your copy of Catalog C-615 from your Sprague distributor, or write to Sprague Products Company, 105 Marshall Street, North Adams, Massachusetts.



WORLD'S LARGEST MANUFACTURER OF CAPACITORS

65-121-63

Circle 3 on literature card

publisher
Howard W. Sams

general manager
Mal Parks, Jr.

executive editor
Verne M. Ray

editor
Forest H. Belt

assistant editor
Thomas A. Lesh

associate editors
George F. Corne, Jr.
Patrick M. Craney

consulting editors
William E. Burke
Joe A. Groves
C. P. Oliphant

production manager
Robert N. Rippy

circulation manager
J. A. Vitt

circulation fulfillment
Pat Tidd, Mgr.
Katherine Krise, Ass't.
Cora La Von Willard, Ass't.

art directors
Dick Lovell
Robert W. Reed

advertising & editorial assistants
Gladys Bauer
Georgeanna Caldwell
Clara Hult
Ellie Rother

photography
Paul Cornelius, Jr.

advertising sales offices
Dave Milling, advertising sales manager

midwestern
Hugh Wallace
PF REPORTER

4300 West 62nd Street,
Indianapolis 6, Ind.
AXminster 1-3100

eastern

Charles Horner
Howard W. Sams & Co., Inc.
3 West 57th Street,
New York, N. Y.
MUrray Hill 8-6350

western

The Maurice A. Kimball Co., Inc.
2550 Beverly Blvd., Los Angeles 57, Calif.
DUnkirk 8-6178; and 580 Market Street,
Room 400, San Francisco 4, Calif. EXbrook 2-3365

Address all correspondence to
PF REPORTER, 4300 W. 62nd Street,
Indianapolis 6, Indiana



Copyright © 1963 by Howard W. Sams & Co., Inc.
PF REPORTER is a trademark of Howard W. Sams & Co., Inc. No part of PF REPORTER may be reproduced without written permission. No patent liability is assumed with respect to use of information herein. Acceptance of advertising does not in any manner signify the products, policies and services so advertised have been approved, endorsed or recommended by this magazine.
Subscription Prices: 1 year—\$5.00, 2 years—\$8.00, 3 years—\$10.00, in the U.S.A., its possessions and Canada.
All other foreign countries: 1 year—\$6.00, 2 years—\$10.00, 3 years—\$13.00. Single copy 50¢; back copies 65¢.

Indexed in *Lectrodex*.
Printed by the Waldemar Press Div.
of Howard W. Sams & Co., Inc.



PF REPORTER

including **Electronic Servicing**
VOLUME 13, No. 10 OCTOBER, 1963

CONTENTS

Highlights of 1964 TV Lines	1
Includes basic specifications of every new black-and-white chassis.	
Letters to the Editor	12
The Electronic Scanner	18
The Troubleshooter	24
Understanding Infrared Energy	26
Servicing Industrial Electronics—What it is, how it is generated, and where it is used.	
Symfact: "Stacked" Video IF (First Two Stages)	29
See what happens to voltages and waveforms when troubles occur.	
Watch Out for Twisters!	34
Shop Talk—TV's are just the opposite of people; the twist results from trouble in the chassis!	
Is an Old TV Worth Repairing?	36
That depends . . . here's how to find out.	
Beware the Vertical Creep!	38
Quicker Servicing—Put a stop to gradual changes in height and linearity.	
Audio Clippers in Communications	44
Two-Way Talk—Various circuits are used to mow the noise peaks off voice signals.	
UHF Antennas—New Boom Ahead?	46
Expansion of all-channel TV is imminent.	
Profits From PA Systems	54
Audio Facts—Suggestions on selling and planning installations.	
Cheerful Charlie's Tribulations	62
Never a dull minute in this shop—darn it!	
Notes on Test Equipment	76
Frequency Meter, Heath Model IM-21 AC VTVM, Karg Labs Model MX-1G Setreo Generator, and SENCORE Model CA125 CRT Checker.	
Product Report	101
Free Catalog & Literature Service	104
Monthly Index	on free literature card

ABOUT THE COVER

What trends in TV receiver design are going to be affecting your service work for the next several years? You can find out by reviewing the technical features of all the new chassis. This is no trouble at all—just turn to page 1.



NEW FROM ATR

ATR

ALL-TRANSISTOR MODEL 707 Karadio

"the oldest name in radio"

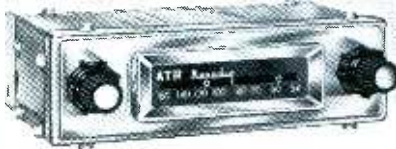

Suggested \$
Retail Price **29.95**

... for those who want the finest! Check the features of this all-new, all-transistor Model 707 Karadio by ATR ... features galore that make sales easier, keep users happier! Compare ... and without hesitation place your order NOW for the new all-transistor ATR Karadio.

- Large easy-to-read illuminated dial.
- Finger-tip tone control to adjust tone as you desire.
- 7-tuned circuits including RF stage to provide maximum sensitivity and selectivity.
- Automatic volume control to keep signals strong and steady.
- Utilizes "solid state" construction employing 7 semi-conductors (5 transistors and 2 diodes).
- Superheterodyne circuit.
- 3-Section Super "Magna-Wave" tuner.
- Hand wired. No printed circuitry.
- Has one-piece self-contained chassis for easy installation.
- "Fits-All" universal construction. For use with practically all import and American cars and trucks.
- Fits under-dash or in-dash utilizing standard trim plate kits.
- Comes complete with built-in speaker.
- External speaker jack provided.
- Available for 12-volt negative ground installations only.
- Low battery drain.

Neutral Gray-Tan baked enamel finish. Overall size approximately 5½" deep x 6½" wide x 2" high. Shipping Weight 5 lbs.

SEE YOUR ELECTRONIC PARTS DISTRIBUTOR
WRITE FACTORY FOR FREE LITERATURE ...
ATR ELECTRONICS, INC.
Formerly: American Television & Radio Co.
Quality Products Since 1931
ST. PAUL 1, MINNESOTA-U.S.A.

Circle 4 on literature card



LETTERS TO THE EDITOR

Dear Editor:

I would like to express my sincere thanks and appreciation to Howard W. Sams & Co., Inc., for allowing us to show our dealers the slide film, "Pricing Your Services for a Profit." We have had several meetings throughout our territory, and I'm happy to say we've had tremendous response from it. I only hope we didn't hold the film too long; we know the demand for it is great.

We are also very interested in showing your "Color TV Review Series" to our dealers.

CARMEN RIAZZI

Srepro Electronics, Inc.
Dayton, Ohio

The "Color TV Review Series" is coming to you under separate cover. Your dealers will undoubtedly want to see several more of the Sams sound-slide film series now available or soon to be introduced. These cover other management subjects, the more efficient use of PHOTOFAC Folders, and various aspects of transistor servicing. Any distributor or service group can arrange for showings of these free films by dropping a line to Tom Surber, Assistant Distributor Sales Manager, Howard W. Sams & Co., Inc., 4300 West 62nd Street, Indianapolis, Indiana, 46206.

—Ed.

Dear Editor:

I've enjoyed reading your articles on two-way mobile radio installation and servicing. "Installing Communications Antennas" in the April, 1963 issue was particularly good. However, since it explained how to cut mounting holes by using a shear punch, it appears the author was not aware of a special cutting tool that is better for this purpose—the Motorola "Antenna-Hole Cutting Tool." Set No. ST-157. This set includes a ¾" cutter for high-band antennas and a 15/16" size for low-band antennas. It is designed to prevent excess penetration that might damage the headliner inside the vehicle, and it also removes a fine line of paint from the edge of the hole to insure a good ground.

EARL WARE

Van Nuys, Calif.

In introductory articles such as this one, our usual practice is to show how jobs can be done with general-purpose tools commonly found in electronics service shops. We agree this special punch set would be a real help in a shop that frequently engages in communications work.—Ed. ▲

PERMALINE 300 OHM TELEVISION Transmission Line

The **only** television wire available today with a 15 year and 25 year written guarantee against:

- DETERIORATION
- CRACKING
- THE EFFECTS OF WEATHERING



Since introducing Permaline over 9 years ago, Columbia has yet to replace one single foot for reasons of deterioration, cracking or brittleness, or due to weather or salt-air conditions. This is the finest television wire available, with insulation unequalled for long life, under the most severe atmospheric conditions.

Why put up with inferior wire, dissatisfied customers, and nuisance calls, insist on Permaline from your distributor.



No antenna is better than the television line that brings the signal to the set. Yet the cost is surprisingly low.

**SEND FOR FREE
SAMPLES AND LITERATURE**

All Columbia Wire and Cable Products are available at distributors everywhere.

Columbia
WIRE & SUPPLY CO.
2850 Irving Park Road - Chicago 18, Ill.

Circle 77 on literature card

STOP!

LOOK!

SAVE!



A STANDARD COLOR BAR GENERATOR

at **1/2**
THE COST OF OTHERS

only **\$99⁵⁰**

All crystal controlled

the all new SENCORE CG126 STANDARD COLOR BAR GENERATOR

A standard color bar, white dot, crosshatch generator especially made for field service on color TV . . . and at a great savings to you.

Check these outstanding features and you will see why this generator belongs on the top of your list for color TV servicing.

All patterns crystal controlled offering "rock like" stability. You'll think the patterns are painted on the TV screen.

Simplified operation speeds up every servicing job. Just dial the standard keyed bars, white dots, crosshatch, vertical bars or horizontal bars and watch them "pop" on the screen. That's all there is to it.

Exclusive adjustable dot size. The white dots can be adjusted to the size that satisfies your needs by a screwdriver adjustment on the rear. No need to argue about dot size anymore. Just select the size that you like to work with best.

Pretuned RF output to Channel 4. Other low channels can be selected if Channel 4 is being used in your area by simple slug adjustment. Patterns are injected directly into antenna terminals, simplifying operation and saving servicing time.

Reserved output on color bars for forcing signal through defective color circuits. The color output control is calibrated at 100 percent at the center of rotation, representing normal output. A reserve up to 200 percent is available on the remainder of rotation.

Smaller and more portable. With color receivers weighing much more than black and white TV, portable equipment becomes essential for home servicing. The CG126 weighs less than 10 pounds and measures only 11" x 8" x 6".



Ten standard keyed color bars (RCA type) that automatically provide all colors at specified NTSC phases . . . but without need of interpretation when servicing.

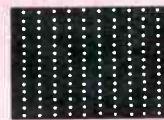

Stable white dots with new exclusive dot size adjustment in rear.

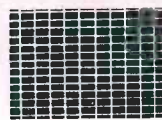

Stabilized crosshatch pattern for simplifying convergence adjustments.

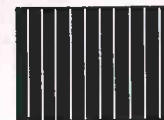

10 thin white vertical lines for horizontal dynamic convergence adjustments . . . often missing on other generators.



14 thin horizontal lines for vertical dynamic convergence. Also missing on many high priced generators.

March into your local parts distributor and demand the CG126 Sencore color generator that sells at 1/2 the price of others. Don't let him switch you.

SENCORE

426 SO. WESTGATE DRIVE • ADDISON, ILL.

Circle 5 on literature card

SENCORE

SIMPLIFIES COLOR SERVICING

NEW! CA122

COLOR CIRCUIT ANALYZER

A simple approach to a complex problem

Here is an instrument that is designed to eliminate the guesswork in color TV servicing. A complete analyzer that provides all required test patterns and signals for testing from the tuner to the tri-color tube. Additional analyzing signals for injection at each stage including audio, video and sync, brings to life a truly portable and practical TV analyzer for on the spot service; virtually obsoleting other analyzers with the advent of color. Sencore's simplified approach requires no knowledge of I, Q, R-Y, B-Y, G-Y or other hard to remember formulas. The CA122 generates every signal normally received from the TV station plus convergence and color test patterns.

The CA122 offers more for less money:

TEN STANDARD COLOR BARS: The type and phase that is fast becoming the standard of the industry. Crystal controlled keyed bars, (RCA type) as explained in most service literature, offer a complete gamut of colors for every color circuit test.

WHITE DOTS: New stabilized dots, a must for convergence, are created by new Sencore driving circuits.

CROSS HATCH PATTERN: A basic requirement for fast CRT convergence.

VERTICAL AND HORIZONTAL BARS: An added feature to speed up convergence, not found on many other color generators.

SHADING BARS: Determines the ability of the video amplifier to produce shades (Y Signal) and to make color temperature adjustments. An important feature missing on other generators.

COLOR GUN INTERRUPTOR: For fast purity and convergence checks without upsetting color controls. Insures proper operation of tri-color guns, preventing wasted time in trouble shooting circuits when CRT is at fault.



A must for color . . .
a money maker for black and white TV servicing

ANALYZING SIGNALS: RF and IF signals modulated with any of the above patterns for injection into grid circuits from antenna to detector. IF attenuator is pre-set for minimum signal for each IF stage to produce pattern on CRT thus providing a check on individual stage gain. Sync and video, plus or minus from 0 to 30 volts peak to peak, have separate peak to peak calibrated controls for quick checks on all video and sync circuits. Crystal controlled 4.5 mc and 900 cycles audio simplify trouble shooting of audio circuits.

NEW ILLUMINATED PATTERN INDICATOR: A Sencore first, offering a rotating color film that exhibits the actual color patterns as they appear on color TV receivers. Locks in with pattern selector control.

You'll pay more for other color generators only.

Dealer Net 187.50

NEW! PS120 PROFESSIONAL WIDE BAND OSCILLOSCOPE

A portable wide band 3 inch oscilloscope for fast, on-the-spot testing. An all new simplified design brings new meaning to the word portability . . . it's as easy to operate and carry as a VTVM. Though compact in size, the PS120 is powerful in performance: Vertical amplifier frequency response of 4 MC flat, only 3 DB down at 7.5 MC and usable to 12 MC, equips the technician for every color servicing job and the engineer with a scope for field and production line testing. AC coupled, with a low frequency response of 20 cycles insure accurate low frequency measurements without vertical bounce. Sensitive single band vertical amplifier; sensitivity of .035 volts RMS for one inch deflection saves band switching and guessing. Horizontal sweep frequency range of 15 cycles to 150 KC and sync range from 15 cycles to 8 MC (usable to 12 MC) results in positive "locking" on all signals. New exclusive Sencore features are direct reading peak-to-peak volts — no interpretation; dual controls to simplify tuning; lead compartment to conceal test leads, jacks and seldom used switches. Rear tilt adjustment angles scope "just right" for easy viewing on bench or production line.

Size: 7" w x 9" h x 11 1/4" d. Weight: 12 lbs.

Dealer Net 124.50
(with low cap. probe)

Kit 74.50



A must for servicing color TV in the home . . . lowest priced broad band scope. All hand wired — all American made

Circle 6 on literature card

CHECKS AND REJUVENATES ALL PICTURE TUBES WITHOUT ADAPTORS OR ACCIDENTAL TUBE DAMAGE

Featuring Automatic Controlled Rejuvenation

The All New SENCORE CR125 CATHODE RAY TUBE TESTER

An all new method of testing and rejuvenating picture tubes. Although the method is new, the tests performed are standard, correlating directly with set-up information from the RCA and GE picture tube manuals.

Check these outstanding features and you will see why this money making instrument belongs on top of your purchasing list for both monochrome and color TV testing.

Checks all picture tubes thoroughly and carefully; checks for inter-element shorts, cathode emission, control grid cut-off capabilities, gas, and life test. Checks all picture tubes with well filtered DC just like they are operated in the TV set.

Automatic controlled rejuvenation. A Sencore first, preventing the operator from over-rejuvenating or damaging a tube. An RC timing circuit controls the rejuvenation time thus applying just the right amount of voltage for a regulated interval. With the flick of a switch, the RC timer converts to a capacity type welder for welding open cathodes. New rejuvenation or welding voltage can be re-applied only when the rejuvenate button is released and depressed again.

Uses DC on all tests. Unlike other CRT testers that use straight AC, the CR125 uses well filtered DC on all tests. This enables Sencore to use standard recommended checks and to provide a more accurate check on control grid capabilities. This is very important in color.

No adaptor sockets. One neat test cable with all six

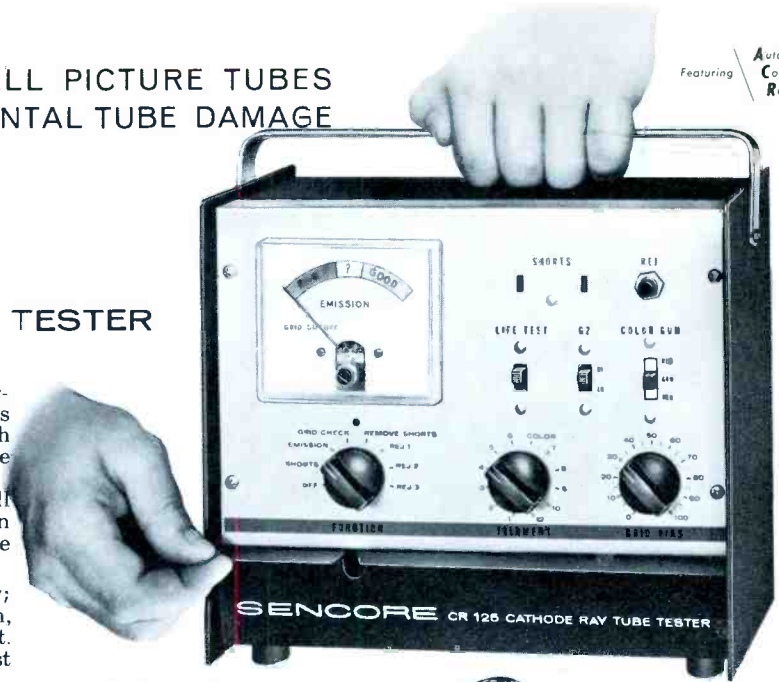

All six sockets, including latest color socket, on one neat cable.



sockets for testing any CRT. No messy adaptors, reference charts or up-dating is required. The Sencore CR125 is the only tester with both color sockets. (Some have no color sockets, others have only the older type color socket.)

No draggy leads. A neat, oversized compartment, in the lower portion of the CR125 allows you to neatly "tuck away" the cable and line cord after each check in the home.

Model CR125 \$69.95

MODEL CR128
For the man on the go. Same as above but in all steel carrying case . . . \$69.95

PS127 DELUXE WIDE BAND OSCILLOSCOPE AT A SURPRISINGLY LOW PRICE

This all new 5 inch oscilloscope offers the finest in performance, portability and appearance. Vertical amplifier frequency response, flat within 1 DB from 10 CPS to 4.5 mc and only 3 DB down at 5.2 mc insures true waveform reproduction. Vertical amplifier sensitivity of .017 volts RMS for one inch deflection on wide band (without band switching) is found only on scopes costing hundreds of dollars more. High input impedance of 2.7 megohms shunted by 99 mmfd (or 27 megohms with 9 mmfd with built-in low capacity probe), insures minimum circuit loading. For the first time, waveforms can be viewed in TV horizontal and vertical output circuits with the low capacity probe that will withstand up to 5000 volts peak to peak. To top that, the vertical amplifier attenuator controls are calibrated directly in peak to peak volts for fast direct reading of all peak to peak voltages.

Horizontal amplifier extended sweep range from 5 to 500 kc in five overlapping steps and frequency response from 10 CPS to 1 mc within 3 DB insures linear sweep and positive sync. External inputs for horizontal sweep and sync, intensity modulation, and smart two-toned case and "designer" styled controls brands the PS127 a truly professional oscilloscope.

PS127 \$169.50



Circle 7 on literature card

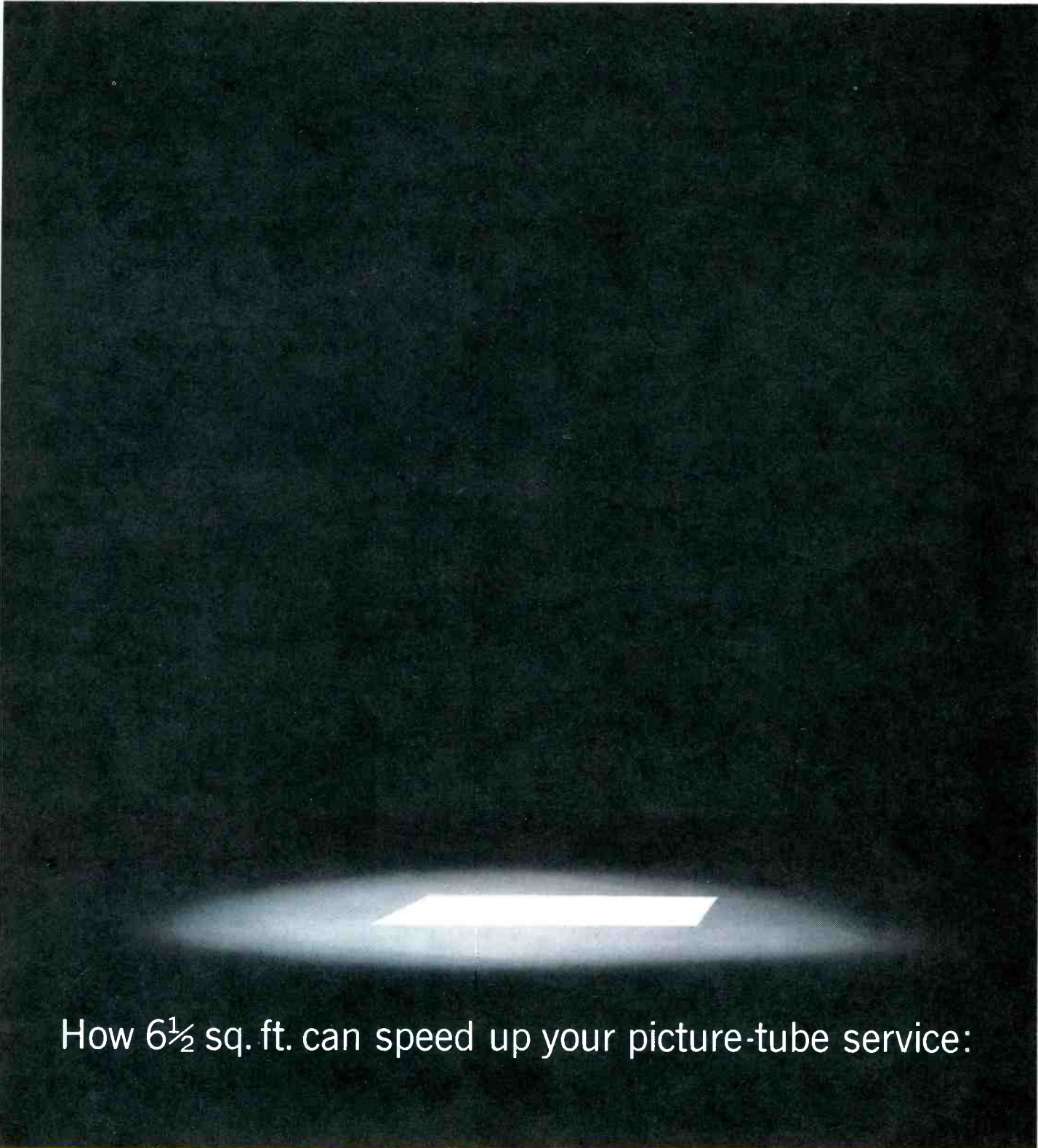

How 6½ sq. ft. can speed up your picture-tube service:

10 versatile "Universal" picture-tube types from Sylvania's SILVER SCREEN 85 line may be all you need to fill 52% of your renewal needs! This fact, verified by a recent industry survey, stems from a remarkable streamlining of the Sylvania line—making fewer, more versatile types that can be used as replacements for many others. Already 54 types can replace 217.

Think what the versatility of these "Universal" tubes

can mean. An in-shop inventory of a few popular types can help you quickly take care of most of your renewal calls. Ordering is simplified...and distributor calls for special tubes can be cut way down.

Start profiting now from Sylvania's SILVER SCREEN 85 picture tubes. Call your Distributor and put an inventory in your own shop—where it can enhance your reputation for fast service and quality replacements.

SILVER SCREEN 85 Picture Tubes are made only from new parts and materials except for the envelopes which, prior to reuse, are inspected and tested to the same standards as new envelopes.



use it for **SILVER SCREEN 85[®]** tubes...
 (10 "Universal" types meet half of all renewal needs)



The "Big 10" Tubes that fill
 52% of all renewal needs:

- 21CB4A } 24%
- 21ZP4B } 41%
- 21AC4A } 52%
- 21YP4A }
- 21EP4B }
- 21FP4C }
- 24AE4 }
- 21DF4 }
- 21AUP4A }
- 21DE4A }

SYLVANIA

SUBSIDIARY OF
GENERAL TELEPHONE & ELECTRONICS



Circle 8 on literature card

NOW! CASTLE OFFERS YOU THE BIGGEST BARGAIN IN TV TUNER OVERHAULING!

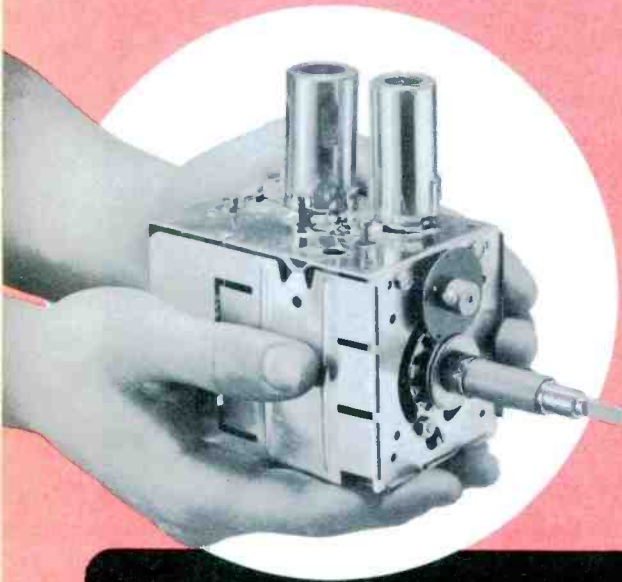

**ALL MAKES
ALL LABOR
AND PARTS
(EXCEPT TUBES)*
ONE PRICE**

995

THIS ONE LOW PRICE INCLUDES ALL UHF, VHF
AND UV COMBINATION* TUNERS

In a decade of experience overhauling TV Tuners of ALL MAKES, Castle has developed new handling and overhauling techniques which give you . . .

Fast Service

A recent study at our Chicago Plant revealed that of all tuners accepted for overhauling, over 30% were completed and shipped within . . . **Seven Hours** . . . all others within 24 Hours.

Simply send us your defective tuner complete; include tubes, shield cover and any damaged parts with model number and complaint. 90 Day Warranty.

Exact Replacements are available for tuners unfit for overhaul. As low as \$12.95 exchange. Replacements are new or rebuilt.)

*UV combination tuner must be of one piece construction. Separate UHF and VHF tuners must be dismantled and the defective unit only sent in.

Pioneers in TV



Tuner Overhauling

CASTLE

TV TUNER SERVICE, INC.

5701 N. Western Ave., Chicago 45, Illinois
653 S. Palisade Ave., Cliffside Park, New Jersey
Canada: 136 Main St., Toronto 13, Ontario

*Major Parts are additional in Canada

Circle 9 on literature card

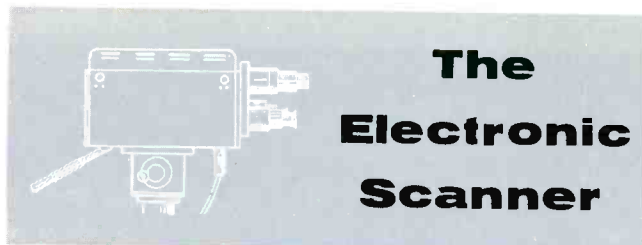

The Electronic Scanner

Here Comes Santa Claus

A wide selection of Christmas premiums will be available to radio and TV service dealers in October and November through authorized **General Electric** tube distributors. Some of the premiums are a 17" girl doll who talks, a water rifle that spurts water 35', and a complete camera outfit that includes film, flash gun and bulbs, batteries, and clip-on neck strap. Also to be given away are a tube caddy which resembles fine luggage, an electric carving knife, and a set of color Christmas cards with a service theme.

Into New Quarters

The Magnavox Co., 52-year-old manufacturer of home entertainment products and industrial and military electronic equipment, has leased more than 8000 square feet of office space on the 15th floor of the Union Carbide Building in New York. The new quarters will house the Marketing, Advertising, Finance, and Public Relations departments. In addition, the firm will move some of its headquarters executives to New York from the home offices in Fort Wayne, Indiana.

"Need A Needle?"

Mr. Herbert Borchardt, president of **Recoton Corp.**, has announced a program to help insure more needle business. In cooperation with Columbia Records, they are releasing an exclusive 12" LP album featuring 10 of today's top artists and tunes. The needle buyer may obtain this album for only \$1 and the label from the box containing a Recoton diamond needle. Dealers can obtain attractive display cards with necessary coupons and four-color window streamers.

Now in CB, Too

Vokar Products, Inc. has entered into the competitive Citizens-band vibrator market with the release of three heavy-duty synchronous vibrators. The units are designed to handle large currents, with 71% more contact area than in previous models. Two units are 6-volt, 4-prong types, while the third is a 12-volt, 4-prong type. One 6-volt vibrator will handle up to 5 amps, and the other, up to 10 amps. The 12-volt unit will handle up to 6 amps. All vibrators measure 2 5/8" high and are 1" in diameter.

UHF Converters Go West

By stocking their new line of UHF converters at their Los Angeles plant, **Standard Kollsman** plans to supply more quickly the growing UHF markets in the West Coast area. The converters are manufactured by the firm's tuner division at the Melrose Park, Illinois plant.

Diode With Whiskers

Standard Telephones and Cables Limited, a British associate of **International Telephone and Telegraph Corp.**, has developed a low-level microwave mixer, using a double-whisker germanium diode. Designated STC-type DK-211, the new 6000-mc down-converter diode was designed to reduce the impedance presented to the 70-mc IF strip. This impedance—normally 200 ohms for the best germanium mixers—is reduced to 100 ohms with the new unit. In manufacture of the DK-211, double whiskers are placed on a single germanium die to form two small junctions in parallel.

FREE!

Your Own AMF Bowling Ball...
or any of over 30 Wonderful Gifts in

PHILCO'S

Fall Fiesta



AMFLITE Bowling Ball... for men, women or youngsters. **YOURS FREE** with purchases of only \$375!

Your choice of scores of wonderful gifts FREE with your purchases of Philco Parts, Accessories and Tubes included in Philco's Fall Fiesta Catalog! Big savings... as well as wonderful gifts, just in time for Fall and Christmas. Get Your Philco Fall Fiesta Catalog NOW... see your Philco distributor... stock up on parts and accessories you need... **AND GET THE GIFTS YOU WANT, TOO!**

**ALL THESE
OTHER WONDERFUL GIFTS... YOURS FREE**
with your purchases of
Philco Fall Fiesta Catalog Merchandise

	FREE with your purchases of merchandise worth
AMF Rugger Bowling Bag	\$125
Daisy CO ₂ Gas Operated Pistol	\$225
AMF Roadmaster Hawk Bicycle	\$700
Bridal-Trousseau Doll Set	\$110
Famous Lionel Train Set	\$200
Daisy Thundercap Tank	\$ 55
Men's Million Miler Luggage	
One Suiter	\$400
Two Suiter	\$450
Three Suiter	\$500
Attache Case	\$275
Ladies' Million Miler Luggage	
16" Hat Box	\$250
21" Overnighter	\$275
26" Pullman Case	\$450
Ladies' Orlon Sweater	\$135
Ladies' Antron Cardigan Sweater	\$175
Ladies' Suburban Coat	\$350
Men's Melton Loden Coat	\$350
Men's Imported Rain Coat	\$350
Men's OuterJac	\$175
Men's Lambs Wool Cardigan	\$175
Men's Runabout Nylon Coat	\$350
Weather Trio (Instruments)	\$130
Outdoor Thermometer	\$ 15
Stanley Ratchet Driver Set	\$ 65
Oneida Dinner Ware	\$350
Oneida Stainless Flatware	\$450
8 Piece Cutlery Set	\$130
Hamilton Cosco Table and Chair Set	\$550



Luxurious
MINK and Cashmere Ladies'
Sweater by Dalton

YOURS FREE with purchases of only \$1300 of Philco Fall Fiesta Catalog merchandise.



Famous
SCHICK TRAVEL-ALL
(Shaver, pre-shave, after-shave and grooming kit in handsome travel case.)

YOURS FREE with purchases of only \$225 of Philco Fall Fiesta Catalog merchandise.

GET YOUR FREE Fall Fiesta Gifts NOW... See Your PHILCO Distributor Today



PARTS & SERVICE OPERATIONS

PHILCO

A SUBSIDIARY OF *Ford Motor Company*

WINEGARD COLORTRON

MODEL C-44 — \$64.95

World's most powerful TV antenna

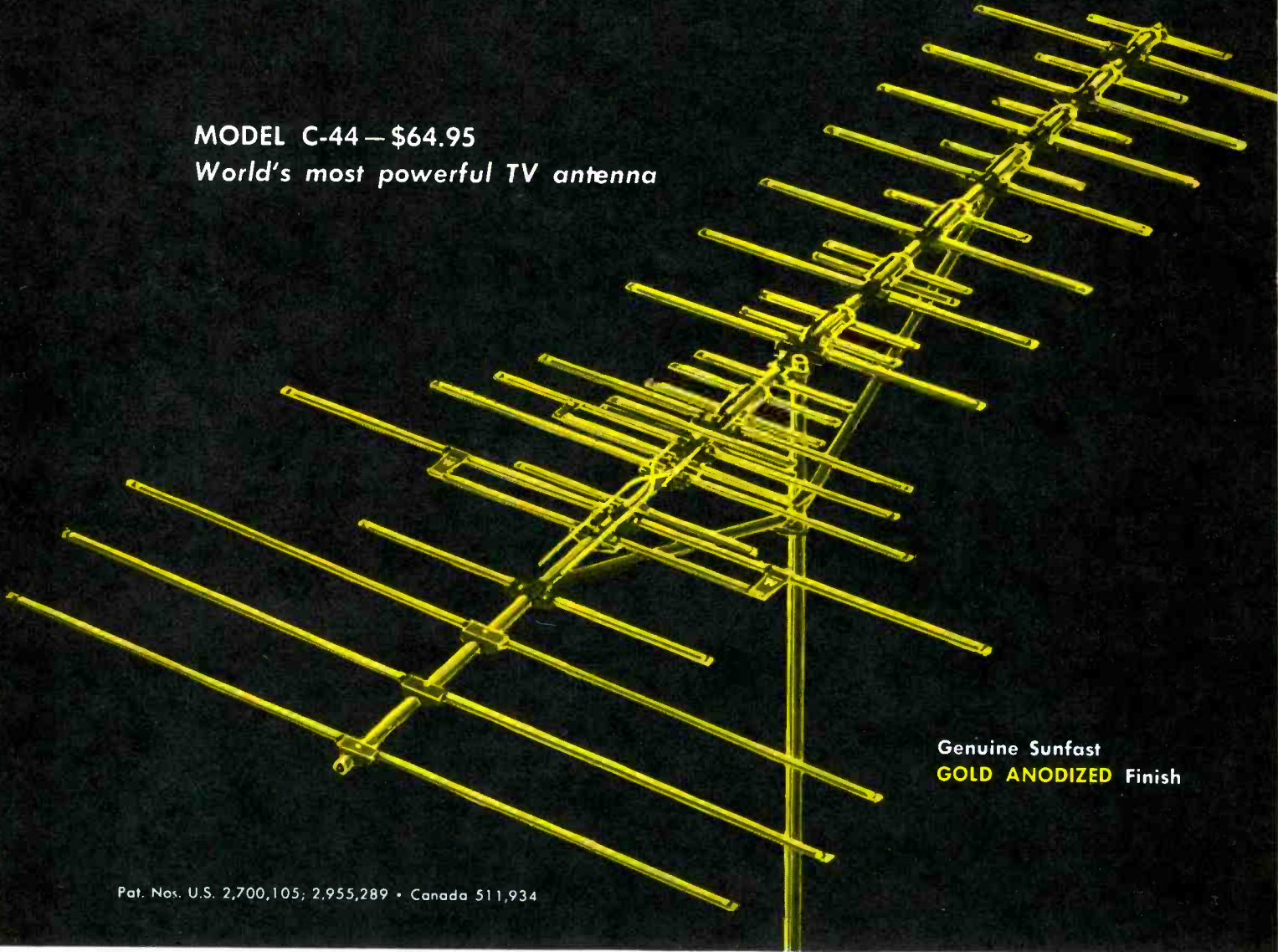

Genuine Sunfast
GOLD ANODIZED Finish

Pat. Nos. U.S. 2,700,105; 2,955,289 • Canada 511,934

FIRST IN PERFORMANCE! FIRST IN CONSTRUCTION QUALITY! FIRST IN APPEARANCE!

Antennas come. Antennas go. But Winegard's *patented* Electro-Lens all channel yagi continues to be the standard of excellence. You can see its influence in the design of every high gain antenna made today.

Because Winegard COLORTRONS *are* recognized as the standard of excellence in TV antennas, you'll find them in every state of the union and 42 foreign countries. Four models satisfy every reception requirement.

WINEGARD COLORTRONS deliver today's finest color reception, give a new picture quality to black &

white. And COLORTRONS are rugged. High tensile aluminum tubing for rigidity and stability... insulators with triple moisture barrier... GOLD ANODIZED for complete corrosion-proofing. Winegard GOLD ANODIZING is the finest in the industry —not an inexpensive stain that fades out in a few weeks, but a bright GOLD that lasts for the life of the antenna.

Try a COLORTRON. Test it against any competitive make for performance, construction, appearance. If you're not 100% convinced, we'll take it back. Your satisfaction is guaranteed.

standard of excellence in the industry



FOR
COLOR
OR
BLACK
&
WHITE



COLORTRON TWIN NUVISTOR AMPLIFIER

Has highest input — up to 400,000 microvolts
Has highest output — up to 1,200,000 microvolts
Perfect partner to the COLORTRON ANTENNA!

Winegard's revolutionary new circuit, employing 2 nuvistors, enables the Colortron to overcome the service problems and limitations of other antenna amplifiers. Colortron will not oscillate, overload or cross modulate because it takes up to 400,000 microvolts of signal input. This is 10 times better than any transistor antenna amplifier made. Has highest out-

put, too—up to 1,200,000 microvolts.

Nothing on the amplifier is exposed to the elements—even the terminals are protected. Colortron comes complete with an all AC power supply with built-in 2 set coupler. Colortron model AP-220N 300 ohm input and output \$39.95 list. Model AP-275 300 ohm input 75 ohm output \$44.95 list.

WINEGARD RESEARCH, ENGINEERING AND MANUFACTURING ARE DEVOTED EXCLUSIVELY TO PRODUCTS FOR BETTER TV-FM RECEPTION

Colortron Antenna Model C-43
Gold Anodized — \$51.90

Colortron Antenna Model C-42
Gold Anodized — \$34.95

Colortron Antenna Model C-41
Gold Anodized — \$24.95

Stereotron Antenna Model SF-8
For long distance FM reception
\$23.65

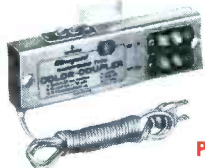

2-Set Color Coupler
Model EC-230 —
transistorized 2-set coupler
boosts signals, couples
2 sets — \$17.95



Red Head Antenna amplifier
Model RD-300—most reliable
transistor TV-FM
antenna amplifier — \$29.95

Nationally
advertised
month after
month



PLUS 3 NEW TV-FM DISTRIBUTION AMPLIFIERS



Model A-215—15 DB gain
\$44.95



Model A-430—30 DB gain
\$84.95



Model A-845—45 DB gain
\$159.95



Winegard
ANTENNA SYSTEMS

3009-10 KIRKWOOD • BURLINGTON, IOWA

Circle 11 on literature card



Pardon us while we change you into Santa Claus

Do your Christmas shopping early at your G-E Distributor's. He has lots of wonderful gifts that you can get with the purchase of General Electric tubes . . . gifts for your family, friends and favorite customers. And there're some you'll want for yourself . . . such as a tube caddy that

looks like fine luggage. You can also get Christmas cards designed only for service dealers . . . to mail to customers and friends.

See your General Electric Distributor and start packing your bag *today*. You're going to be a sensational Santa!

Start packing your bag!



These Kodak Flashfun camera outfits include everything that young photographers need: Hawkeye camera, film, clip-on neck strap, batteries, flash bulbs and instruction manual. They're yours when you buy G-E tubes.



Be good to yourself this Christmas. You can get these Armor Clad® tube caddies when you purchase G-E tubes. They look like fine pieces of luggage and the special vinyl coverings are longer lasting. They are reinforced with nickel plate at all stress points.

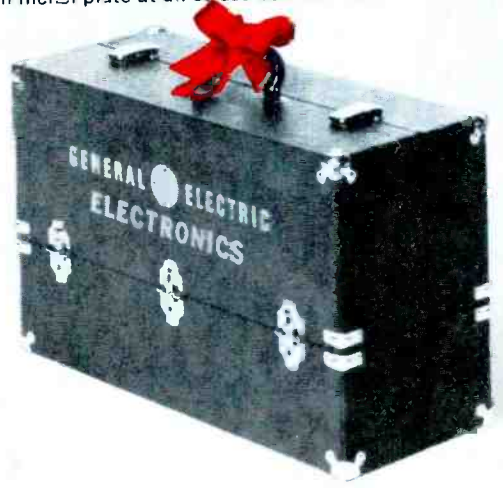

These Dick Tracy Power-Jet Squad Guns by Mattel® will be a hit with any boys you know. They're automatic cap-firing guns that shoot a stream of water 35 feet... farther than any water guns ever made. Give one to any boy and then stand clear.



Little girls will go wild over these Mattel® Sister Belle talking dolls. They're 17" tall and have a rag body and plastic head. Each one says eleven different things that little girls like to hear... like "Let's play house," "Give me a kiss." No batteries needed.



These G-E electric carving knives will make a great gift for the lady of the house. They even slice through hot bread or hot meat with smooth precision. Get several from your G-E Tube distributor.

Get these Christmas cards... prepared especially for you. They're in color on heavy, high-gloss stock and show a cartoon of you adjusting a TV set to say "Happy Holidays." 50 cards and 50 envelopes to a box. Get yours now for early mailing.



ANOTHER ACCENT ON VALUE FROM G-E ELECTRONICS DISTRIBUTORS

Progress is Our Most Important Product

GENERAL  ELECTRIC

Circle 12 on literature card

TO HELP MAKE FUSE HANDLING MORE PROFITABLE . . .

BUSS VISUAL-PAK



CLEAR PLASTIC BOX,
THERE'S NO NEED
TO OPEN
TO SEE HOW MANY
FUSES ARE
IN IT

- BUSS fuse 5-in clear plastic box—let's you check fuses in each box at a glance . . . guards against running short on needed fuses.
- Size and style of fuses printed in large type on lid of box makes it easier to pick out fuses you want.
- Box fits all fuse display stands and channels.

BUSS

PIONEERING NEW
DEVELOPMENTS IN
ELECTRICAL PROTECTION
SINCE 1914

BUSSMANN MFG. DIVISION, McGraw-Edison Co., St. Louis 7, Mo.

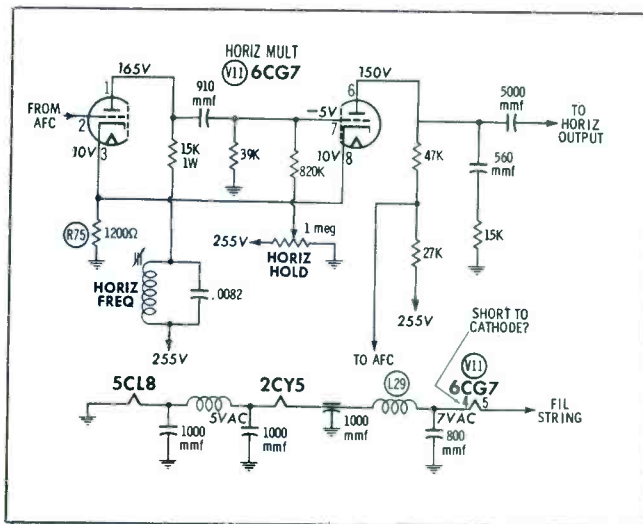

of the socket, or between the printed-wiring conductors that go to these points.

Too Much Sync?

A Motorola QTS-448 chassis (PHOTOFACT Folder 579-2) has unstable sync, and I'm puzzled by the waveform measurements I've obtained in the sync section. The pulse amplitude at the grid of sync limiter V3B is 40 or 50 volts instead of the 11 volts given on the schematic; but on the other side of C40, at the plate of the 6BU8 sync separator, the signal is only 7 or 8 volts in amplitude. I've replaced C40 and K3, have checked all filters, and have even pulled the vertical multivibrator tube to make sure it's not feeding a signal back into V3B.

BUSS : the complete line of fuses . . .

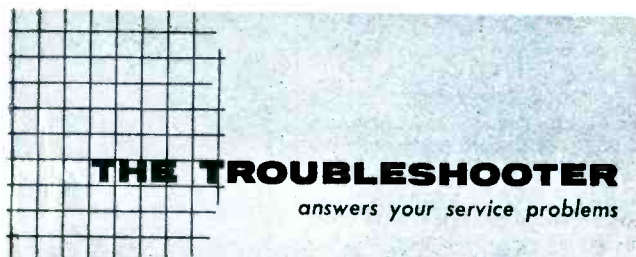

THE TROUBLESHOOTER
answers your service problems

Choked on a Filament

I've replaced a burned filament choke L29 in a General Electric Model 21C1450 (PHOTOFACT Folder 383-3). Now the tubes light up, and the set has good audio, but there is no raster. I suspect trouble in the horizontal multivibrator, because all voltages are far from being normal. For instance, the second section of the tube has only 23.5 volts at the plate (pin 6) and a positive 3.5 volts at the grid (pin 7); the common cathode measures only 2.7 volts. I've practically rebuilt the circuit, having changed all resistors and capacitors shown in the attached schematic, but have had no luck.

GEORGE C. OTTEN

Freeburg, Mo.

The filament choke that burned out is suspiciously close to the 6CG7 horizontal multivibrator tube, both electrically and physically, and I'll wager the trouble involves the filament circuit in some way. For instance, let's suppose the cathodes of V11 have shorted to the filament, either within the tube or via the socket connections. Cathode resistor R75 will then be bridged by a low-resistance path to ground through the tuner filaments. The multivibrator, unable to develop normal cathode bias, will stop oscillating; furthermore, current through one or both sections of V11 will greatly increase, as your voltage readings testify. Look for a short between pins 3 and 4

FUSETRON dual-element fuses time-delay type

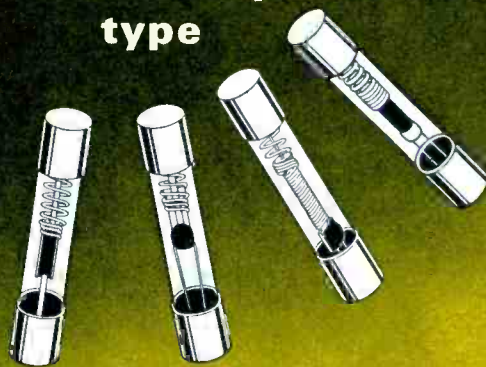

"Slow blowing" fuses for circuits where harmless surges occur. These fuses prevent needless outages by safely holding starting currents or surges, — yet they provide safe, positive protection against short-circuits or continued overloads.

BUSS

Write for BUSS
Bulletin SFB.

BUSSMANN MFG. DIVISION, McGraw-Edison Co., St. Louis 7, Mo.

Circle 13 on literature card

TO HELP MAKE FUSE HANDLING MORE PROFITABLE...

BUSS VISUAL-PAK

ANOTHER BUSS FIRST



CLEAR PLASTIC BOX,
THERE'S NO NEED
TO OPEN
TO SEE HOW MANY
FUSES ARE
IN IT

- BUSS fuse 5-in clear plastic box—let's you check fuses in each box at a glance... guards against running short on needed fuses.
- Size and style of fuses printed in large type on lid of box makes it easier to pick out fuses you want.
- Box fits all fuse display stands and channels.

BUSS

PIONEERING NEW DEVELOPMENTS IN ELECTRICAL PROTECTION SINCE 1914

BUSSMANN MFG. DIVISION, McGraw-Edison Co., St. Lou 7, Mo.

Audio Deception

When a Philco Chassis 7H22U (PHOTOFACT Folder 376-3) is turned on, the sound is sometimes normal; at other times, it is very weak even at full volume. Under both conditions, the grid voltage of the audio output tube is -4 volts, and the cathode voltage is 7 volts (measured from the 140-volt source). Plate and screen voltages are okay. I replaced the 12C5 output tube, and checked all components in the circuit—including filters. In addition, I checked along the 140-volt line and found everything in normal condition.

I'm wondering if you can give me something more to go on, and point out anything I am overlooking.

FRANK W. DISTEFANO

Jersey City, N. J.

The voltages in the audio output stage are probably distracting your attention from the real cause of the intermittent change in volume. Even though they seem to be in error, the important point is that they don't change when the trouble

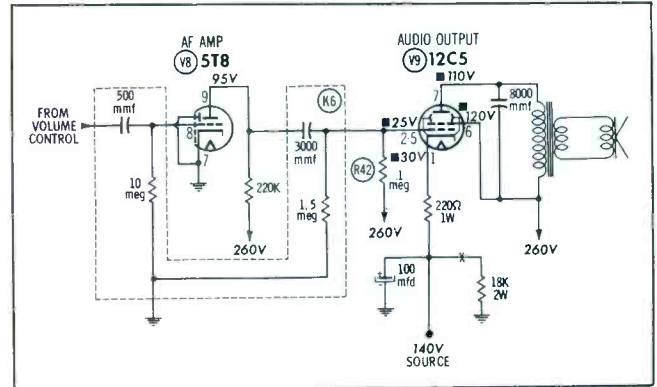

• Please turn to page 82

... of unquestioned high quality

Your recent *Symfact* coverages of this 'BU8 circuit were extremely helpful, but I still don't have the answer to this case.

ROBERT W. D TMR

Englewood, Ohio

The 11-volt amplitude indicated at the grid of V3B may be in error, since much higher signal voltages are the rule for this type of circuit. In any event, the sync limiter (true to its name) should clip off any portion of the sync signal that exceeds the desired amplitude. I don't think the grid waveform you've observed is a cause for worry unless you find video information mixed with it, or unless some of the individual sync pulses are much weaker than others. A clean waveshape is a clue to look in the plate circuit of the sync limiter for the cause of the instability.

The low amplitude of the sync-separator plate signal may simply mean the scope is loading the extremely high-impedance plate circuit.

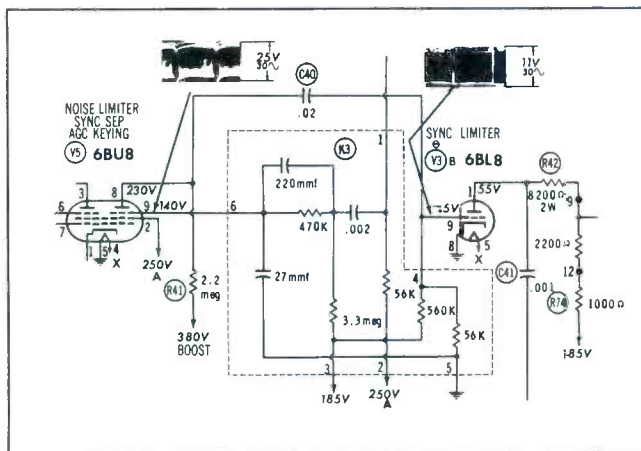

Let BUSS Fuses Help Protect Your PROFITS

To make sure BUSS fuses will operate as intended under all service conditions, each and every BUSS fuse is individually tested in a sensitive electronic device.

This is your assurance that when you sell or install BUSS fuses, you are safeguarded against complaints, call-backs and adjustments that might result from faulty fuses and eat away your profit.

It is just good business to sell fuses the BUSS way.

BUSS

Write for BUSS Bulletin SFB.

BUSSMANN MFG. DIVISION, McGraw-Edison Co., St. Louis 7, Mo.

Circle 13 on literature card

understanding **infrared** energy



All natural substances are composed of charged particles which are constantly undergoing energy changes due to thermal action. These changes generate radiated electromagnetic energy, and the amount of radiation from an object is directly related to its temperature. Most of this radiation is in the infrared portion of the electromagnetic frequency spectrum—that portion which bridges the gap between visible light and the microwaves used for high-definition radar (i.e., from about 500 million down to about 1 million megacycles).

The infrared energy radiated by an object is radiant power, which may be expressed in lumens, lumen-seconds, watts, or ergs. Its frequency is expressed in terms of a wavelength unit—the micron—which is one-millionth of a meter, and is symbolized by the Greek letter μ (mu). The visible portion of the electromagnetic spectrum starts with violet (about 0.4 micron) and extends to deep red (about 0.75 micron)—see Fig. 1. Infrared energy ranges from the latter wavelength to about 1000 microns.

The infrared portion of the spectrum is divided into three main regions, as illustrated in Fig. 2. The near-infrared (NIR) region begins just beyond the long-wavelength threshold of the human eye (about 0.75 micron) and extends to about 1.4 microns. The intermediate-infrared (IIR) extends from 1.4 to about 5.6 microns, while the far-infrared (FIR) region covers the remainder of the spectrum from 5.6 to about 1000 microns.



Fig. 1. The electromagnetic spectrum.

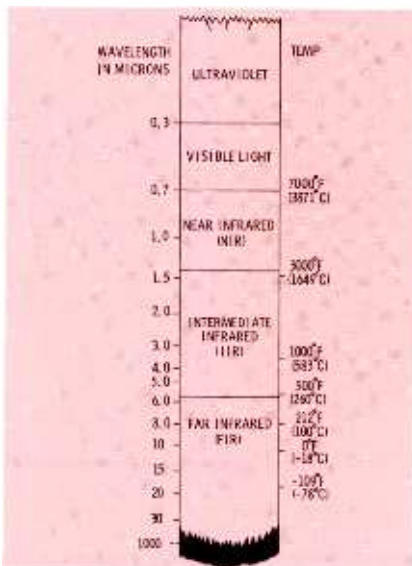

Fig. 2. The infrared portion of the spectrum is divided into three regions.

Characteristics of Infrared

Some of the characteristics of infrared energy are similar to the properties of visible light; others more closely resemble those of radar waves. Parabolic mirrors and lenses can be used to collect and focus infrared energy (as with visible light); yet infrared radiation will pass through silicon and germanium, which are opaque to visible light.

As illustrated in Fig. 3, radar waves are usually generated by tuned circuits, whereas ultraviolet rays and X-rays originate in electron transitions within atomic structures. Infrared energy is generated in still another way: by molecular thermal action caused by excited electronic charges within the molecules of any object whose temperature is above absolute zero.

The chart of Fig. 4 shows that the temperature of the sun is about 2000° C., and its electromagnetic radiation reaches a peak at approximately 0.5 micron. Another signifi-

cant temperature is that of a bright red-hot object, about 1000° C. (just a little hotter than a jet exhaust); this corresponds to an energy peak of 2.25 microns in the IIR region. Boiling water is 100° C., of course, and has a peak at 7.8 microns. Finally, an object at a room temperature of 20° C. has a peak radiation characteristic of about 10 microns.

Although any object which absorbs infrared radiation will increase in temperature, infrared radiation should not be confused with "heat waves," which are formed by the transfer of thermal energy by convection or conduction. Thermal transfer requires a physical medium such as air through which the heat can travel; infrared energy can be propagated through a vacuum as well.

Infrared radiation is sometimes incorrectly called "heat radiation" because it is emitted by all warm objects, and objects which absorb infrared energy become warm. But infrared radiation itself, though "hot," is not "heat."

Infrared Systems

Infrared systems are classified as "passive" when the natural radiation of an object is utilized, or "active" when the object must be il-

●Please turn to page 98

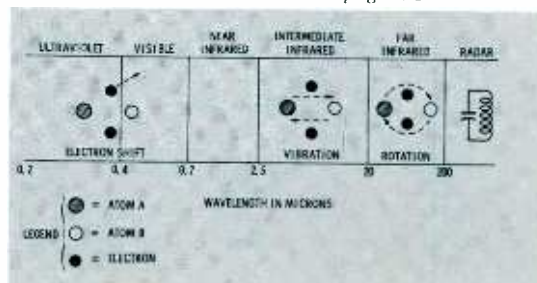
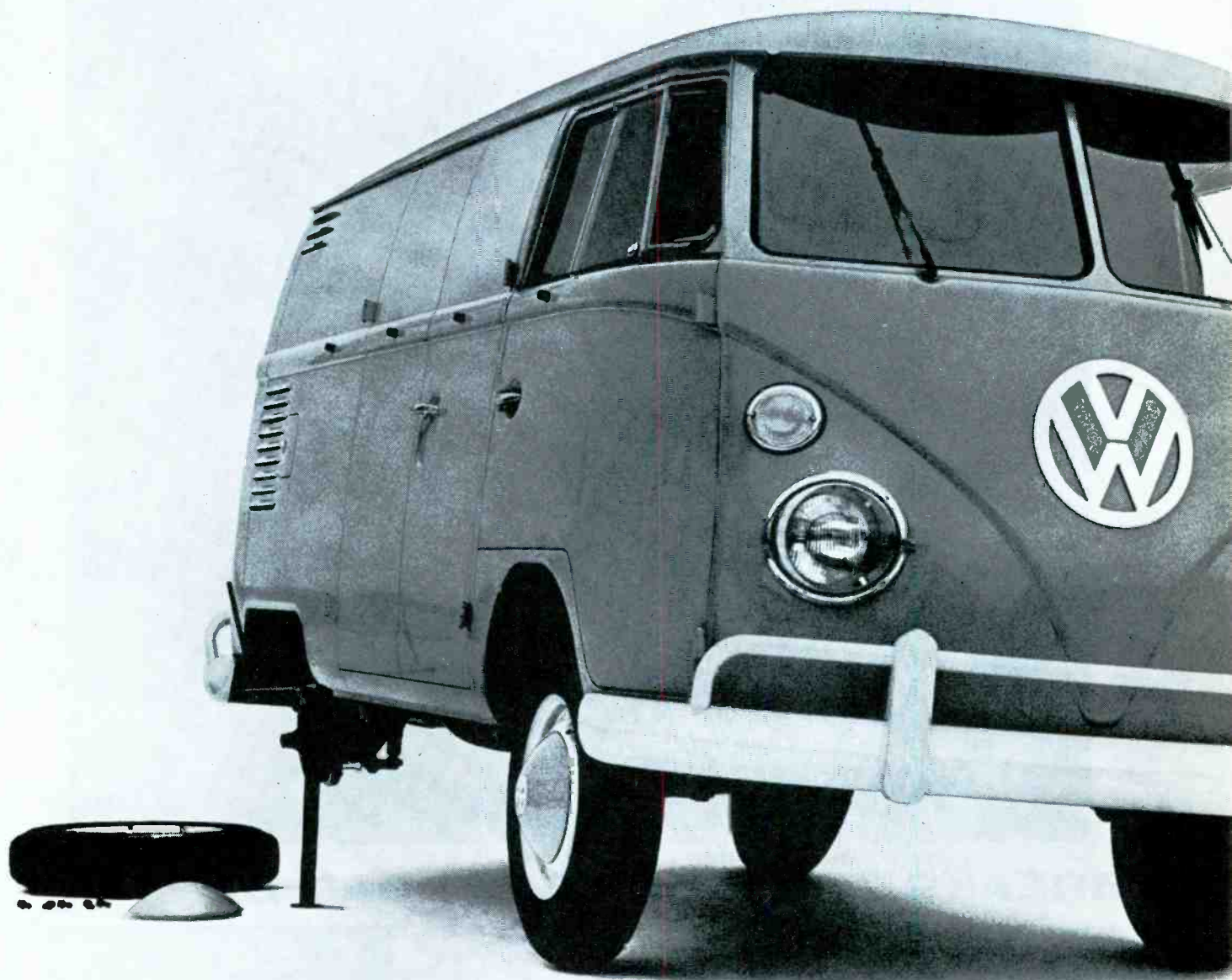

Fig. 3. Various types of radiation are due to different physical phenomena.



© 1963 VOLKSWAGEN OF AMERICA, INC.

When do the tires give up?

Some owners never find out.

We advertise 35,000 miles to a set. Some get closer to 60,000.

You can safely expect 15,000 miles more than you get with a regular truck.

The tires on a VW aren't loaded down with heavy fenders, frame, or hood.

We weld our truck into one solid hunk to make it light and solid.

This takes nearly a half ton off the tires. (Which is also one half ton you don't buy gas for.)

Even our engine saves you weight.

It's made of aluminum-magnesium alloy. (Lighter and stronger than aluminum itself.)

And you never need water or anti-freeze. So you don't even have to haul

a radiator.

When you load the Volkswagen, the cargo sits in the middle because the engine's in back.

The tires share the load equally.



Even at that, though, some VWs won't get 35,000 miles. A lot depends on the roads. We don't build those.

NEW TWIN-TRANSISTOR SUPER POWERMATE

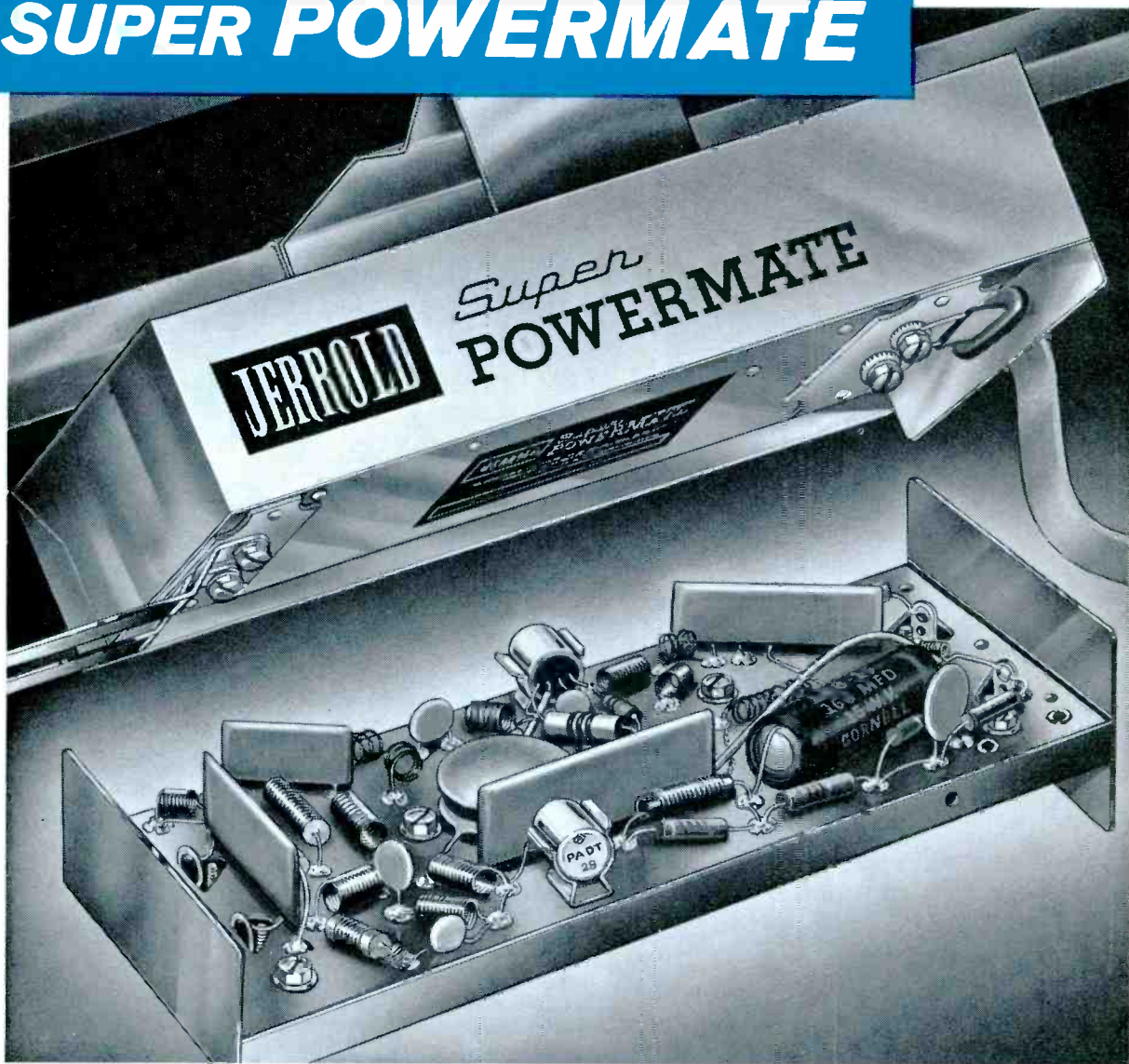

BREAKS THE GAIN/OVERLOAD BARRIER

Servicemen and the public long wanted it, but were told they couldn't have it—a transistorized TV antenna preamplifier with the overload capacity to handle local signals without sacrificing the gain that brings in distant stations.

But Jerrold did what couldn't be done. With the new twin-transistor SUPER POWERMATE, you have, for the first time, a transistor preamplifier with the high gain and low noise figure that made the original Jerrold Powermate famous—plus an unprecedented overload capability for local-signal situations. SUPER POWERMATE offers a gain range from 15.5db with 700,000 μ v max. output at Channel 2, to 11.3db with 200,000 μ v max. output at Channel 13. There are no tubes or nuvistors to replace. And frequency response is fantastically flat—a boon to color TV.

Sell new SUPER POWERMATE, the all-channel antenna preamplifier with G/O—the industry's best Gain/Overload capability. List \$44.95. See your Jerrold distributor or write Jerrold Electronics, Philadelphia 32, Pa.

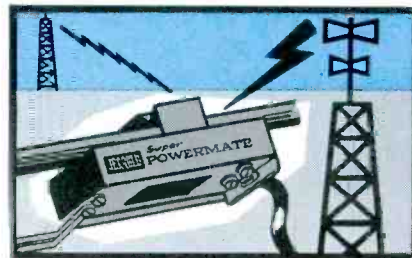

GAIN to reach far-distant stations, OVERLOAD capability to prevent local-signal interference.

SUPER POWERMATE **G/O**
HAS
GAIN OVERLOAD

Circle 15 on literature card

JERROLD
ELECTRONICS

A subsidiary of The Jerrold Corporation

First Two Stages

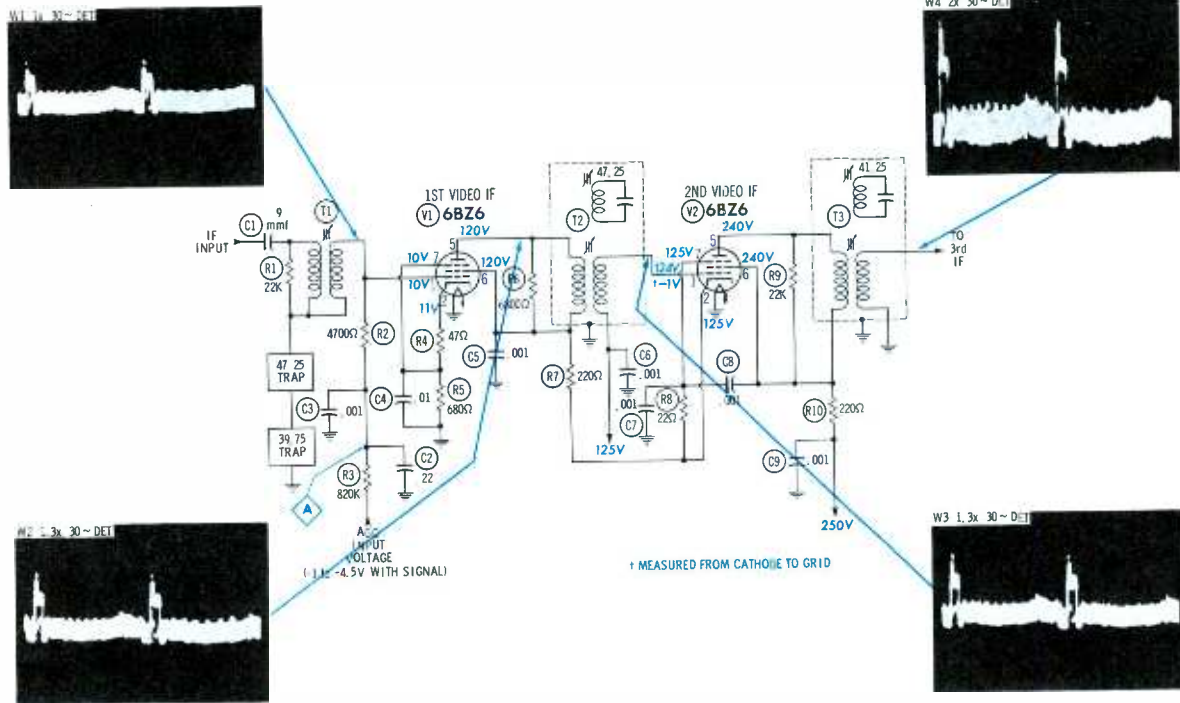

DC VOLTAGES taken with VTVM, on inactive channel; antenna disconnected from set. * Means voltage varies with conditions — see "Variations."

WAVEFORMS taken with high-gain scope; controls set for 40-volt p-p video to CRT. Demodulator probe (det) necessary to obtain video signals.

Normal Operation

"Stacked" stages operate like most other IF's; main difference is fact that V1 and V2 are series-connected across B+ supply. DC plate-current path is through R5, R4, V1, T2, R7, V2, T3, and R10 to B+ source. Plate and screen voltages for V1 (approximately half of B+) are thus obtained via V2. In this particular receiver (Curtis Mathes Chassis 12), grid return for V2 is connected directly to 125-volt source. Other receivers may use resistive divider network across main B+ line to obtain correct operating bias on V2. Change in AGC voltage varies grid voltage of V1, and resulting change in plate voltage is passed to cathode of V2, controlling gain of second IF stage. When troubleshooting circuits of this type, keep in mind that correct operation of either tube depends on correct operation of the other. All normal and abnormal waveforms were obtained with scope equipped with demodulator probe (except with direct probe at point A). Probe detected positive swings of RF signal, so all waveforms (grid and plate) have positive polarity. Scope must be high-gain type, to show minute signals present in IF strip—particularly at input. Designations 1.3x, 2x, etc., indicate waveform amplitudes as compared with that of normal W1; for example, W4 is approximately twice the value of W1. You'll notice no trouble symptoms due to misalignment have been described. When a technician has any suspicions of misalignment, it is suggested he verify them by connecting proper sweep-alignment equipment and checking overall response.

Operating Variations

- V1 PIN 1** DC voltage and W1 amplitude both depend on strength of incoming signal, due mainly to changes in developed AGC voltage. Average voltage with strong station signal ranges from -1 to -4.5 volts. Voltage may shift one or two volts positive with very weak signal.
- PIN 2** Voltage developed across R4-R5 varies according to cathode current, which is dependent on voltage applied to grid. Fairly strong input signal increases grid bias by AGC action, thus reducing cathode voltage to 3.5 volts.
- PINS 5, 6** Because applying station signal decreases V1 conduction, average voltage on plate and screen rises to 130 volts. W3 is only 1.3x W1 with nominal signal; however, V1 is capable of more amplification when needed in fringe areas.
- V2 PIN 1** Bias measured by connecting VTVM between grid and cathode ranges from -3 to -4 volts in presence of strong signal. Supply voltage fed to grid increases approximately 10 volts with signal, due to reduced loading on low B+.
- PIN 2** DC voltage is higher with signal (nominal value 130 volts; maximum 140 volts). Voltage is mainly controlled by operating conditions in first IF stage.

Tunable Ghosts

SYMPTOM 1

Sound Fairly Normal

T2 Primary Open

Symptom Analysis

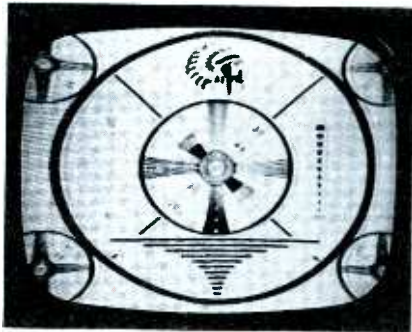

Multiple ghosts appear on strong stations in area; weaker stations produce washed-out picture, with critical horizontal sync. No reception of fringe-area signals. Fine-tuning control is touchy and, when rotated, causes images to move across picture.

Waveform Analysis

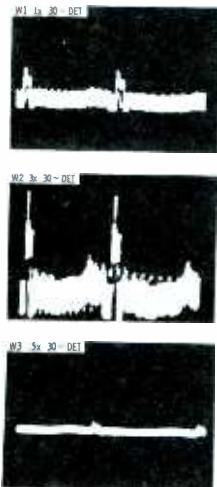

Signals in IF stages have normal waveshapes, but wrong ratio of amplitudes. Comparing W2 and W3 gives main clue: much lower amplitude of W3 proves signal is highly attenuated by T2. W2 is three times as strong as W1; gain of V1 is far above normal. Although W3 is weak, it is amplified enough by following stages to produce clear picture on CRT. Scope won't reveal actual trouble, but note how quickly it pinpoints defective stage.

Voltage and Component Analysis

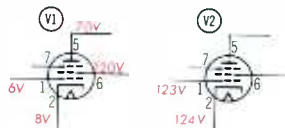

Interpretation of voltages on V1, with no signal, pinpoints open T2. Plate voltage is definitely low, though screen voltage is normal; great voltage drop is explained by open T2 winding, bridged by R6. Had R6 opened, plate voltage would be closer to normal, tunable ghosts would still be present, and excessive peaking in tuned circuit of T2 would tend to cause video overloading. Grid voltage on V1 is positive, even with signal, because AGC circuit receives false impression of weak signal at antenna.

Best Bet: Isolate with scope—then usual VTVM tests.

Weak Picture

Audio Buzz; Critical Sync

SYMPTOM 2

T2 Secondary Open

Symptom Analysis

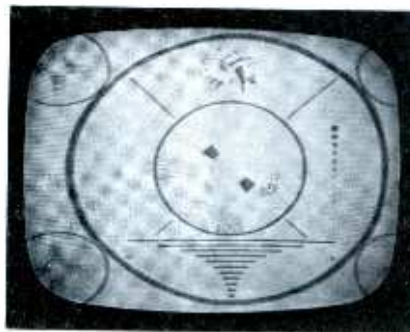

Strong stations produce washed-out picture; weak stations produce only sound with buzz. Rotating AGC control is of little help; at most settings, both sound and video are lost. Contrast control is operative, indicating video output is probably okay. Sync is critical.

Waveform Analysis

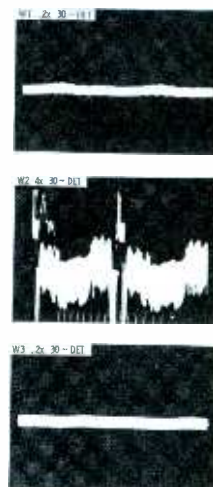

W1 contains small amount of video, but amplitude is only .2x normal. In this instance, it's low due to misadjustment of fine tuning, necessary to obtain best picture on screen. W2 proves V1 is operating at high gain, for its amplitude is 20 times that of W1. Gain in first IF stage seldom reaches such proportions in most sets. W3 gives conclusive evidence that signal is lost in T2—signal here should be same as W2 at plate of V1.

Voltage and Component Analysis

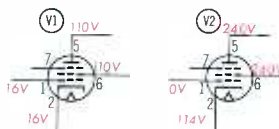

Open secondary winding of T2 is easily spotted by routine voltage checks on V2; high positive voltage on grid is missing. Voltages on V1 bear out evidence, provided by high amplitude of W2, that first stage is amplifying more than normal. This condition is explained by high positive voltage on grid (16 volts, even with signal present), simply a clue that signal passing through IF strip is too weak to let AGC system develop negative voltage in proportion to strength of RF signal being received.

Best Bet: Localize with scope; pinpoint with VTVM

No Video, No Audio

SYMPTOM 3

No Snow in Raster

R10 Increased in Value

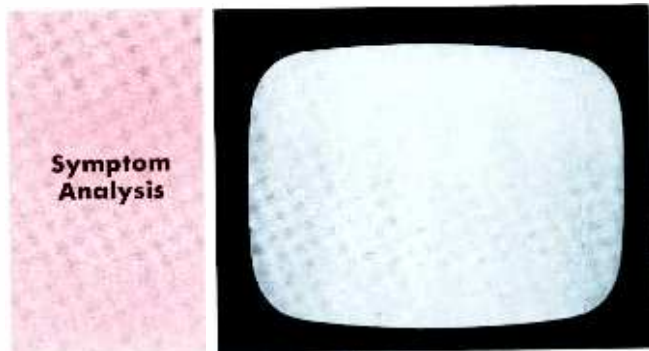

Symptom appears similar to failure of mixer-oscillator stage; no station signals can be received. Contrast control has no effect when adjusted. However, rotating AGC control causes momentary flash of video and audio, so tuner is probably operating okay.

Waveform Analysis

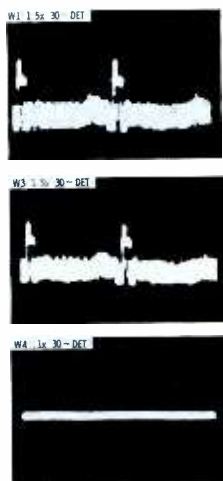

A check for presence of W1 proves signal is coming from tuner in good shape. Likewise, suitable W3 indicates first IF stage is operative. W4 immediately arouses suspicion of defective second IF stage—only random, low-level noise is present, with little trace of video. Scoping back at plate of V2 reveals same waveform, isolating trouble to incorrect operating conditions in circuit of V2. As before, scope is effective in isolating faulty stage.

Voltage and Component Analysis

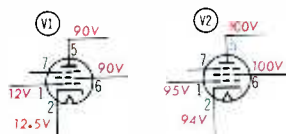

It's best to analyze all voltages on both V1 and V2 before drawing definite conclusion. Biggest clue is low plate reading on V2. Upset voltages on V1 are result of change in operation of V2. However, 95 volts on grid of V2 could be misleading; 125-volt source itself has dropped to 95 volts, due to heavy current drawn in other stages—especially video output—as a result of losing signal. With this type of B+ system, it's a good idea to recheck source voltages (with either tube removed) before condemning either IF stage.

Best Bet: Scope to localize; VTVM to pinpoint.

Snowy Picture

Sound Normal

SYMPTOM 4

C1 Leaky

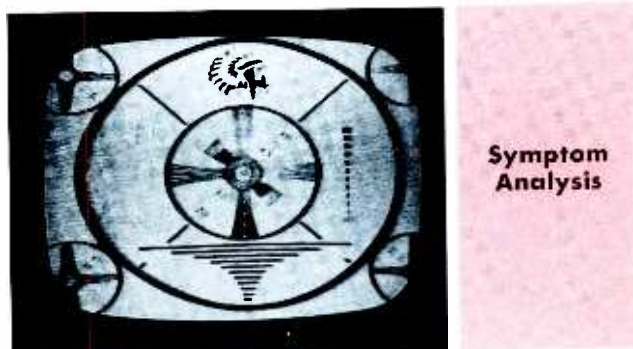

Snow gives impression RF amplifier is weak. However, video on screen is fairly strong—a slight clue that IF's could be at fault. Weak stations can be received, and with somewhat less snow. Adjusting AGC control decreases snow, but only at point of video overload.

Waveform Analysis

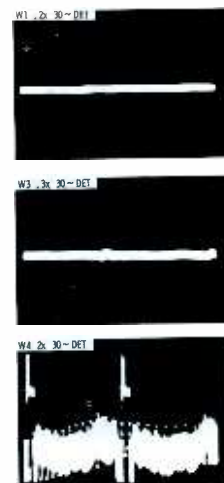

Viewing W1 and W3 gives no information to contradict initial idea that RF amplifier stage may be defective; little but noise is present in these waveforms. Vague clue of less snow on weak stations isn't enough to indicate whether trouble is in tuner or IF stages. Normal amplitude of W4 suggests V2 is running at unusually high gain, since input signal is very small. This is no real clue to defect, but does tie it to point prior to second IF.

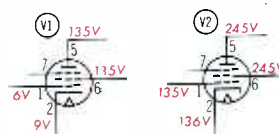

Voltage and Component Analysis

Best voltage clue is positive voltage on grid of V1 (with or without signal). However, AGC fault could be causing this positive reading. Finding real cause boils down to isolation technique. AGC source voltage is negative (with signal), so negative voltage should also be present on controlled grids. High negative AGC does reach tuner—explaining snow, since RF stage is not amplifying. Positive voltage leaking to grid of V1 via C1 overcomes AGC and allows "stacked" IF to amplify weak input—with snow—strongly.

Best Bet: Use VTVM to pinpoint trouble.

Overloaded Picture

SYMPTOM 5

Poor Horizontal Sync; Audio Buzz

C2 Open

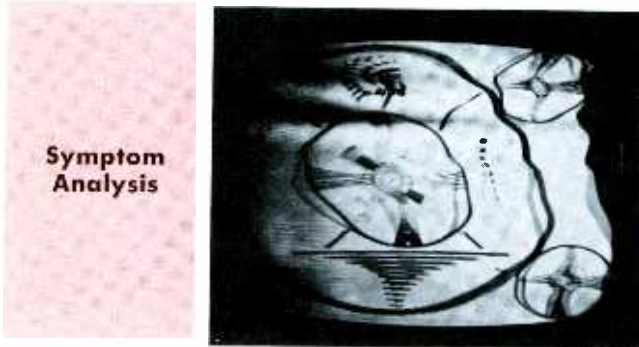

On all local-area stations, screen pattern gives familiar indications of overload due to AGC failure; fringe-area signals produce only horizontal pulling. AGC control worsens condition when adjusted in one direction, blanks video in opposite direction.

Waveform Analysis



Possibility of AGC trouble should lead servicemen to clamp AGC line. Connecting bias box—even without setting proper clamping voltage—returns picture to normal; this seems to indicate poor AGC filtering. Removing box and checking for ripple content at point A confirms suspicion—high-amplitude pulse is present. Normal waveform on AGC line is in second photo.



Voltage and Component Analysis

**NO
VOLTAGE
CLUES**

All DC voltages on both V1 and V2 check acceptably close to those of normal operation, giving no big clue to trouble. AGC circuit still develops correct negative voltage, although main filter C2 is open. Ripple in insufficiently filtered AGC voltage, fed to grid of V1, mixes with incoming station signal; composite signal passes through IF, video, sync, and AGC circuits in “round robin” fashion, resulting in erratic operation of all stages carrying picture signal (or dependent on signal for correct operation). Defect sometimes causes complete loss of horizontal sync, necessitating readjustment of horizontal hold control.

Best Bet: Clamp AGC line; or scope for ripple.

Weak, Washed-Out Picture

SYMPTOM 6

Sound Fairly Normal

R5 Increased in Value

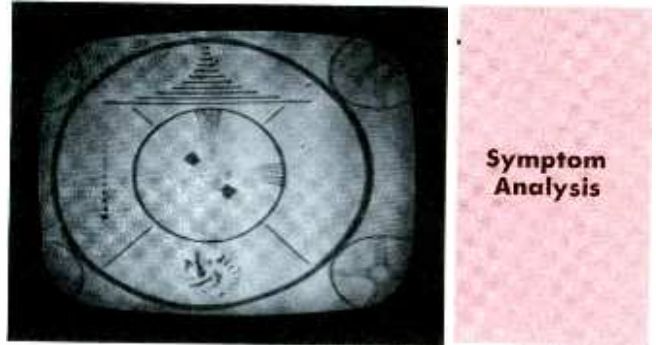

Contrast and AGC controls are operative; adjustment of either control improves picture, but fails to return good video. Weaker stations have secondary symptoms of poor horizontal sync and slight audio buzz. No snow appears in raster on unused channels.

Waveform Analysis

Amplitude of W1 (1.5x) is higher than during normal operation, merely as a result of less AGC bias applied to RF stage. W1 offers no clue unless it's compared to W2 or W3. W2 is not even half the amplitude of W1; surprisingly, V1 is acting as attenuator, rather than amplifier. W4 is also lower than W2 because change in V1 affects gain of second IF stage.

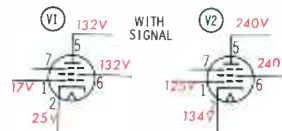
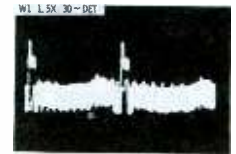

Voltage and Component Analysis

DC voltages on V1 (with signal) explain incorrect relationship of W1 and W2. Even with unusually positive voltage on grid, high drop across cathode bias network—due to R5 increase—holds down conduction through tube. Higher plate and screen voltages naturally result. Notice effect on grid and cathode voltages of V2 resulting from operating change in V1. Cathode voltage is higher as direct result of change in V1 plate voltage; however, voltage applied to grid is almost same as under no-signal conditions. If tubes were not stacked across B+, operation of V2 would not be affected so drastically.

Best Bet: Use scope to isolate; VTVM to pinpoint.

NEW!

by
ANTENNA-CRAFT

GOLD BONANZA



ALL CHANNEL TV ANTENNAS

BETTER BUILT FOR BETTER PERFORMANCE

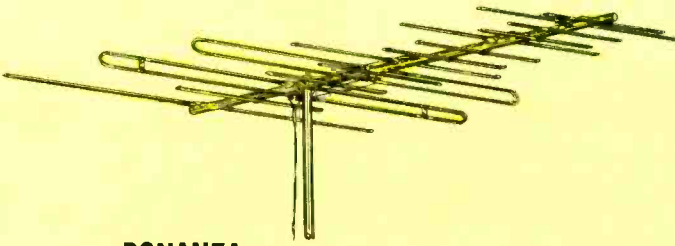

BONANZA WARRIOR
B58G — \$32.95

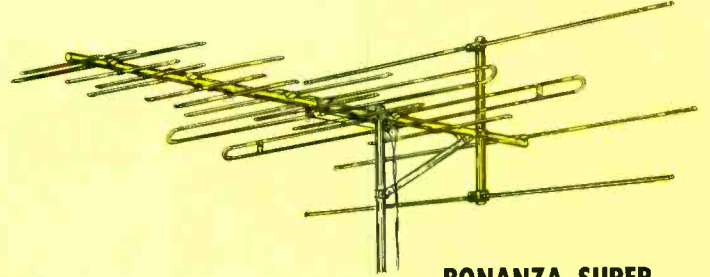

BONANZA SUPER CHIEF
B-59G — \$39.95

Antennacraft antennas are manufactured by the nation's leading manufacturer of UHF-VHF-FM antennas using the widely accepted and proven folded, driven dipole system, which is broad in frequency response over the entire FM or TV spectrum. Therefore **MAXIMUM PERFORMANCE** is assured for both black and white and **COLOR**. The Bonanza line is finished with a factory applied, tough, non-fading finish in beautiful Dura-Gold. *Antennacraft* is also your best source for area special antennas designed for black and white or color. *Antennacraft* antennas are the nation's finest, and are sold by more dealers who really know the antenna field than any other make. It is worth your time to find out about this line if you do not now stock *Antennacraft*. Dealer inquiries welcomed.

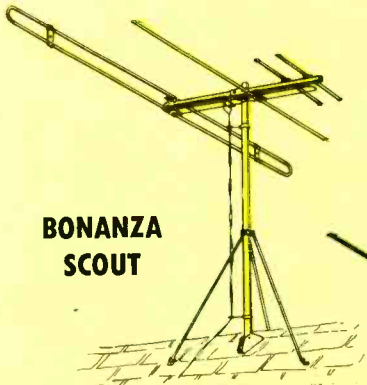

BONANZA SCOUT

B51G — \$9.95
B51KG — \$14.95

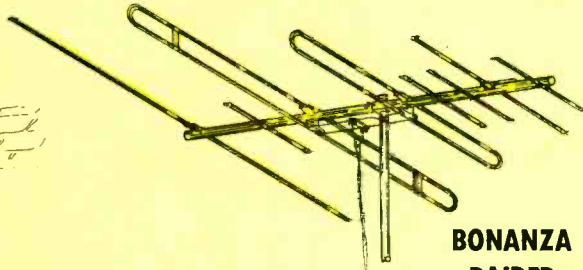

BONANZA RAIDER
B52G — \$17.95

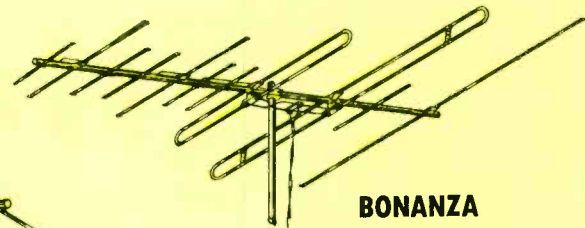

BONANZA CHIEF
B57G — \$24.95

ANTENNA-CRAFT ANTENNAS

Are distributed nationwide. There is a distributor in your area. Write for information.

ANTENNAS BY

Antennacraft Company

Burlington, Iowa

Circle 16 on literature card

watch out for

TWISTERS



Fig. 1. Extreme twist due to cathode-filament short in a video IF tube.

Complaints of twisted pictures are one major source of “tough-dog” service jobs. For each case easily cured by replacing a tube, the serviceman is likely to encounter several that require extensive troubleshooting.

Part of the difficulty is caused by the large number of circuits in which twist troubles can arise; about the only section of a TV receiver that is free from them is the



(A) Severe picture distortion

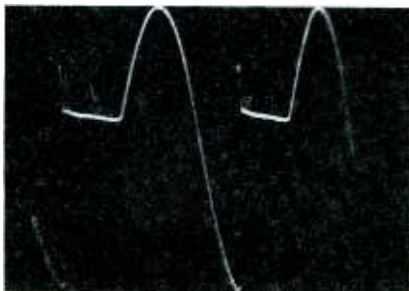

(B) Signal across filter, 200V p-p

Fig. 2. Open filter capacitor in half-wave supply causes S-shaped twist.

sound circuit, and I’m not sure it’s completely immune. Besides the vast amount of circuitry that might possibly be involved, the twist symptom is associated with hard-to-check defects that make the trouble more difficult to find and correct.

The slightest imperfections in soldered, riveted, or welded connections—especially in those which serve to ground more than one component or circuit—can cause noticeable twist effects. Although the accounts of such “tough-dog” twist cases fill many pages in TV service literature, the fact remains that a service technician has no simple way to detect by measurement the minute resistance responsible for the twisting.

Marginal defects in filter capacitors are also frequent offenders. One of these faults is high inductive reactance, which does not interfere with normal smoothing or bypassing of low-frequency ripple, but does prevent efficient filtering of higher-frequency signals (video, sync, and sweep). Other faults, fairly common in multisection filters, are AC coupling and DC leakage between sections. These defects are often beyond the checking capability of service-shop capacitor testers.

One other cause of twist is pickup of magnetic flux. In one specific instance, pickup from the power transformer affected the ringing coil in the horizontal multivibrator. The cure was very simple: move the ringing coil to a different location or shield it. A more common type of twist due to electromagnetic fields appears when a set owner installs a CRT brightener himself, neatly taping it to the neck of the picture tube!

Troubleshooting Clues

The servicing of any sticky trouble is made easier if the service technician considers the trouble in its simplest terms. Twist, for example, can be recognized as being the result of modulating the horizontal deflection. This simple analysis is the foundation of a troubleshooting approach, which can be expanded on by seeking the answers to two pertinent questions:

Where is the modulation being introduced? The distortion could be originating in the horizontal circuit itself, in the sync section, or even in one of the picture-signal stages.

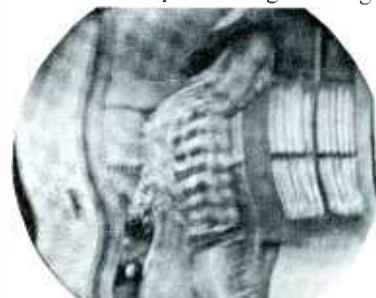

(A) Curves and shading in raster



(B) Ripple in video signal

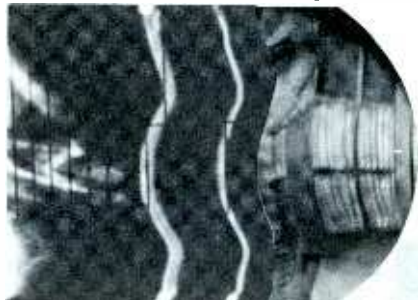

(C) Signal—sideways—vs. picture

Fig. 3. Double twist due to excessive 120-cps ripple from full-wave supply.

What kind of modulating signal is present? The most common culprits are low-frequency ripple waveforms from the power supply or filament circuit, and stray video introduced by faulty operation of circuits that pass the sync signal.

Troubleshooting is aided by analyzing the twisted picture for additional clues. For example, if it also contains shaded bars running across the screen, the offending modulation is probably present in the video signal feeding the picture tube. When there are no bars, but vertical hold is more critical than normal, the modulation is most likely entering only the sync circuits. If the twist is not accompanied by either picture shading or critical hold, it can usually be assumed that modulation is directly affecting the horizontal sweep signal.

The nature of the twist-producing signal is disclosed by the number and shape of bends in the picture. Easiest to diagnose is the twist that takes the form of two symmetrical S curves from top to bottom of the screen. This condition can always be related to 120-cps ripple modulation, and hence



(A) Twist near bottom of picture

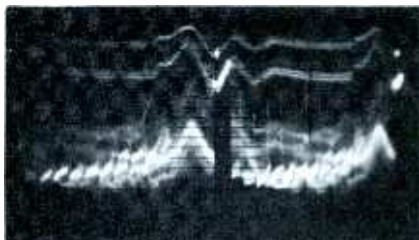

(B) Corresponding video distortion

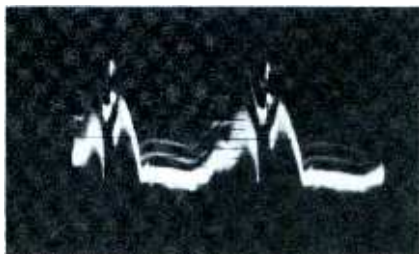

(C) Signal on bad filter. 5V p-p

Fig. 4. Effect of open ground connection on a multiple-section filter can.

suggests poor filtering in a full-wave power supply.

Similarly, a single S curve is caused by 60-cps ripple from filament circuits or half-wave power supplies. This latter type of distortion is not always as easy to recognize as 120-cps twist. Instead of describing a clear-cut S curve, it may cause picture bending during only a portion of each vertical sweep cycle; at other times, it may bend the center of the picture and make it appear to billow like a sail in a breeze.

Multiple twists are seen in two different forms. In a steady state, they are ordinarily the result of a defect in the horizontal circuit. (Piecrust ripple is the most common condition in this category.) Erratic multiple twists can usually be seen to vary in step with the contents of the picture. The more severe distortions ordinarily result from a sync-circuit defect, and the less severe ones from compression in the video-signal circuits.

Although these general rules are extremely useful in analyzing most twisted pictures, there are enough exceptions that service technicians would do well to think twice before accepting clues at face value. One such exception concerned a set with a stable five-cycle pigtail curl at the top of the picture—presumably a horizontal-circuit fault. This clue was contradicted by the presence of shaded bars, which suggested video-circuit trouble. Bench servicing finally resolved the question by locating a bad filter in the horizontal circuit. The shading was due to modulation at the accelerating anode of the picture tube, resulting from the same capacitor fault that caused the curling.

Extreme Cases

Severe "twisters" are probably the easiest to service. Because of the extremely odd symptoms produced, the serviceman is likely to have information on similar, previous cases filed away in that mental catalog called his "memory." Furthermore, since extreme twisting effects can result only from very strong modulation of horizontal sweep, the source of the modulation is not difficult to find.

In Fig. 1, Popeye is reeling from a punch in the face, administered by a cathode-to-filament short in

an IF tube. The single S curve due to 60-cps modulation is pretty clear, although the shading due to hum bars is not as severe as might be expected.

The S curve in Fig. 2A was caused by an open input filter in an Admiral using a half-wave B+ voltage doubler. A tube short might have been suspected in this case, too; but because the chassis was brought in to me for bench servicing, I grabbed the scope and checked across the filters before trying tubes. The result (Fig. 2B) showed me the trouble in much less time than it would have taken me to change tubes and wait for them to heat up.

Fig. 3A is a classic case of double S-curve twist, due to an open filter in a Zenith which derived B+ from a full-wave power supply. Two faint, dark bands indicate 120-cps modulation in the signal feeding the picture tube (Fig. 3B). A composite photograph of the picture and the video waveform (Fig. 3C) shows how twist in a picture dovetails with distortions in the scope trace.

Peculiar Intermittent

A frequent cause of twist at the very top or very bottom of the picture is a poor ground connection on a multiple-section filter capacitor. The picture defect (Fig. 4A) is easy to identify when associated with the scope trace of the video signal (Fig. 4B); once the trace

●Please turn to page 94



(A) No shading to match the twist

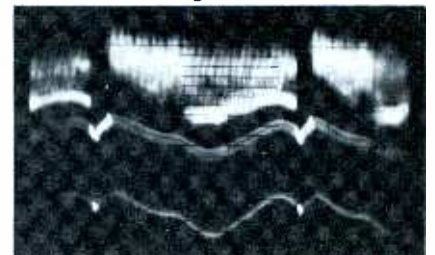

(B) Video output was distorted

Fig. 5. Unusual power supply in one Philco TV set caused ambiguous clues.



is an **OLD TV** worth repairing?

A check list for quickly sizing up a set's condition

by Thomas A. Lesh

Most TV sets have "had it" by the time they reach the age of 8 to 10 years. Although they can be kept running with proper maintenance, the need for major repairs arises more and more frequently. Service bills can pile up so fast that the owner would save money in the long run by buying a new set. In the light of this economic situation, many service shops are tending toward a policy of discouraging all but the simplest repairs on any set above a certain age.

But this seemingly practical approach may cause shops to turn down perfectly good service business! Some sets nearly 10 years old still have enough useful life remaining to justify a moderate amount of repair work; premature scrapping is a wasteful move that is against the best interests of both the customer and the shop. A serviceman can attract profitable *plus business* by keeping old sets in operation, if he can sharpen his ability to recognize those worth maintaining.

As we'll see, a systematic check list can be devised to aid in quickly estimating the condition of receivers. However, a technical analysis isn't enough; it's also important to sound out the owner and see if he's likely to be satisfied with the results of service work.

Talk With the Owner

As pointed out in "Keeping Your Service Sold" (July PF REPORTER), the owner of an old set may have to be diplomatically told that it is nearing the end of its useful life. In deciding whether to have it repaired or to trade it in, he must weigh the chances of continued dependable performance against the probable cost of repairs. A family that can't immediately afford a new set is of-

ten perfectly willing to "get by" with the old one if reasonable operation can be restored at a sensible cost.

The prospects of success in servicing an old set are favorable if—and only if—the following conditions exist:

1. The owner displays a generally cooperative and understanding attitude.
2. When shop work is necessary, he agrees to pay the regular charge for service, or else wait and let the serviceman do the work in a slack period when a special reduced rate can be offered. (If the customer has a low income, or there's a chance the set may prove impractical to repair, some shops consider it good business to make estimates at little or no cost.)
3. The owner is willing to gamble on the length of time the set will run before the next trouble develops. You can truthfully tell him it *might* operate for a year or more, though there's no guarantee it will.
4. Those who watch the set can tolerate minor imperfections, like touchy sync or a less-than-bright picture tube. For an old receiver, a *complete* cure may be difficult and expensive, and a tolerant attitude toward small flaws will permit lowering repair costs. Unreasonable call-backs will be minimized, too.
5. The old receiver will be used only occasionally, or as a second set. In either case, there should be less demand for "like-new" performance or rapid repair service; furthermore, the set has a better chance of lasting a long time. An infrequently used old receiver is an excellent example of *plus business*; if abandoned, it may not be replaced.

SOS—Spry Old Sets

All the time the serviceman is talking to the set owner, he's working on the receiver; so, common-sense observation will soon answer the question, "Is it worth taking to the shop for repairs, if necessary?" Of course, fairly decent operation can sometimes be restored by tube changing and other simple remedies. If so, all well and good; but most receivers over 7 years old have gone as far as they can go without some under-chassis servicing. A trip to the shop for relatively simple bench repairs can often cure the immediate complaint, straighten out other minor troubles that have been gradually developing over the years, and head off others that are just beginning. Here are some signs that a minor overhaul in the shop might be practical:

1. The trouble that triggered the service call is clear-cut and potentially easy to correct, like a complete loss of sync or a decrease in raster height.
2. If there are other borderline faults, they can probably be either cured or endured without much difficulty. In fact, chances are they've already been ignored for some time. Examining the set and questioning the customer should uncover no intermittent or other hard-to-find conditions that, in the *customer's* opinion, could interfere with enjoyment of the set.
3. The set has seen relatively light usage, or at least has not been abused.
4. The set is of a well-known make, and the particular chassis has a reputation for durability.

5. The picture tube is still in usable condition, even if slightly weak.

On the other hand, here are some warning signs that should make a serviceman think twice before pulling an old chassis:

1. "Sound—no raster" trouble, unless the cause is simple and obvious. The old set might have an expensive-to-fix CRT or fly-back trouble, and would be worth repairing only if the customer does not object to the cost.
2. Evidence—from observation or conversation—that the set has had frequent or amateurish repairs.
3. Information that the set has stood idle for a long time, especially in a humid location like a basement.
4. Multiple or intermittent faults, unless the probable solutions are likely to be relatively simple.

General Checkup

When an "old-timer" is accepted for shop work, it needs to be handled somewhat differently from a newer set. Although the serviceman should try to keep costs low by minimizing the time spent in actual work, he can't afford *not* to take extra precautions against callbacks. Longer than usual "cooking" of the repaired chassis *in the cabinet* (to check the effects of heat buildup) is advisable, to catch any new troubles stirred up by probing around in the circuits.

Also, while the set is on the bench, the opportunity should not be missed to check certain key points in the chassis for hidden faults that could soon flare up into real trouble. An offer of a general checkup (with a promise to limit expenses) is a good selling point to help convince the owner of an old set that bench work will be worth the cost. Usually he'll be surprised at the improvement made by a few dollars' worth of new parts, and you've added a degree of preventive maintenance.

Assessing the overall condition of a set at the bench may require as little as 15 minutes beyond the time spent on actual repairs. The first step is a careful visual inspection; then a series of quick tests are made at a number of key check points where aging typically has the most critical effects.

In the visual examination, the general condition of the under-chassis wiring and components should be noted. A clean appearance, with few signs of past service work, is a good omen. Melted wax on tubular capacitors is not necessarily a sign of trouble, but it doesn't hurt to check the voltages and signals on the worst-looking capacitors. If the insulation on leads and components is becoming brittle, slightly changing the lead dress at "pinch points" may prevent a future short. Removing grime from the picture-tube bell and high-voltage circuits will also discourage future troubles due to electrical leakage. Any extensively rebuilt circuits should be earmarked for a critical electrical check, especially if they show sloppy wiring and soldering.

Troubleshooting the primary fault is the next step. When this job has been done—or if it threatens to be time-consuming—a general evaluation of the set's performance is a good idea. Checking the points listed in the left-hand column of Fig. 1 will yield the most information in the least time.

This chart shows the results of checking an old set typical of those still in excellent condition. The check marks along the left edge of the chart are a convenient way for the serviceman to make a record of circuits that may need further work. An attempt should be made to follow up with additional tests in these circuits, to determine whether there is an obvious need for repairs. Borderline conditions can be overlooked only if they seem to be due to simple aging, rather than to an impending breakdown.

Since the time available for additional testing is limited, the service-

man should concentrate on spot-checking previously repaired circuits and those related to any remaining visible or audible symptoms. Tubes need be tested or substituted only to troubleshoot specific faults or to correct a substandard condition noted in the general performance checks. If a tube seems to be doing an acceptable job, leaving it in place will usually prevent unnecessary expense and trouble.

It's a good idea to touch up all service adjustments, but not until the associated circuits have been checked for faults that might be covered up by adjusting. Cleaning all controls and tuner contacts is an excellent final touch.

If voltage and signal measurements reveal slight deterioration of many components, but the serviceman finds it still advisable to go ahead with repairs, he can concentrate on replacing the parts most likely to cause serious trouble if their condition becomes worse. The most important examples are capacitors with high voltage across them, any components in circuits with high pulse voltages, resistors with high power ratings, and critical components in frequency-determining circuits.

Typical Results

Here are two case histories that will show how the lives of some TV sets can be extended by timely repairs:

RCA Chassis KCS66

This 1952 model belonged to a customer who watched only occasional news programs and a few favorite shows; he prized it for its unusually sharp picture. (Video-IF

●Please turn to page 91

CHASSIS RCA KCS66		SERVICE ORDER NO. 19821		OBSERVATIONS	
TEST	NORMAL	ACTUAL	✓	✓	
B+ DC	260V	280V			SET HAS SEPARATE HORIZ AND VERT SYNC CIRCUITS. HORIZ 52V P-P; HOR. ADFJ. VERT. HORIZ 12V P-P; VERT. ADFJ. 15V ACTUAL.
B- RPPLE	.5V P-P	1V P-P	✓	NO DC	PROPORTIONAL TO B+ INPUT
LOW B- DC	155V	165V	✓	NO RPPLE	NEGLECTIBLE
LOW B- RPPLE	NOT SPEC	.5V P-P	✓	NOISE SWEEP	LINE CALL. NEEDED SLIGHT RETOUCH
GRID	500V	530V	✓	ALL	
HORIZ DRIVE	65V P-P	60V P-P	✓	VERT LB AND VERT RB	UNLINED IN PRIMARY PAINT; OK AFTER REPAIRS
HORIZ RPPLE SCREEN DC	170V	185V	✓		
SCREEN OUTPUT CATHODE CURRENT	95 ma	100 ma	✓	NO VOLTAJE	DE-IC ARCING IN BLOOMING
VERT DRIVE FOR NORMAL RETRY	70V P-P	75V P-P	✓	TRAP	CURVE AND STRONG
VIDEO FROM HIT	3.7V P-P	4V P-P	✓	POWER	NO SHOW; USE ADJ. OK; 14-15 LAST INTERVIEWABLE
VIDEO TO CRT	50V P-P 20V DC	50V P-P 20V DC	✓		

Fig. 1. Convenient check list helps in evaluating condition of old TV set.



BEWARE the

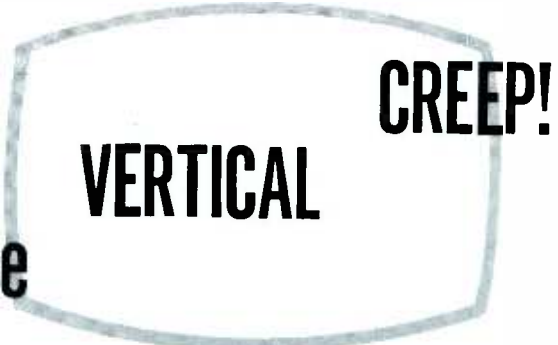

There's a stealthy rascal lying dormant in many television sets, just waiting for the opportune moment to start active trouble. When it does, it often appears and disappears with annoying irregularity, calculated to drive a conscientious serviceman to distraction. This inconsiderate troublemaker is a symptom called vertical "creep."

This symptom can be more accurately described as a gradual change in vertical linearity or height, or both. It wouldn't be so bad if this problem would simply come to stay, like an ordinary symptom; a competent technician could wade in confidently, locate the trouble, and fix it. But not so, with this villain. It usually appears only when the set has been on for awhile; or perhaps after it has been off for awhile; or only in the evening; or maybe once a week, just before a favorite show. There's just no telling when or where this aggravating malady will crop up.

Fortunately, however, there are ways to outwit even the most

sneaky of television symptoms, and the vertical creep is no exception. Taming this particular demon requires a knowledge of two basic techniques: handling thermal intermittents, and analyzing vertical sweep circuits.

Most cases of vertical creep turn out to be some form of thermal intermittent—a defect that occurs with changing temperature, usually as the set becomes hotter and hotter during operation. The techniques pointed out in the August article "Monitoring Helps Spot Intermittents" are extremely useful in tracking down vertical creep. Heating and/or cooling components artificially can help speed up the isolation process. But to attack the problem intelligently, and win the battle in the shortest possible time, you need also to know the most likely causes of these peculiar symptoms; and that comes from an analysis of vertical circuits.

Localizing the Troubled Area

A little deduction will save the

day. Consider the vertical deflection system as a whole: The main purpose of the oscillator or discharge stage is to develop a 60-cps sawtooth signal, while the output stage concerns itself mainly with amplifying that signal and shaping it into the trapezoidal waveform needed to operate the yoke. The yoke, in turn, sweeps the CRT beam in a linear manner from the top of the screen to the bottom. Faulty components in the oscillator stage generally affect frequency, while those in the output stage affect the amplitude (height) and shape (linearity) of the sweep waveform.

Take the circuit in Fig. 1 for example. You'll notice the controls and components that affect size and linearity are in the output stage. (The height control, although connected to determine the DC plate voltage for the oscillator, actually sets the amount of vertical drive signal applied to the grid of the output tube.) From all these facts, you can safely deduce that most linearity and height defects will center around the output stage.

Learning to Analyze

Analyzing circuit operation can save hours of fruitless searching in the wrong spot for a defect. There are two ways to check circuit operation: with your scope (by far the more sure way) and with your VTVM or VOM. Once you know how different symptoms affect circuit operation, you'll have little difficulty pinpointing the exact cause.

Using the Scope

The scope is usually the best instrument to begin troubleshooting with, since it can show you exactly what is happening to the signal waveform; and, after all, that is the most important consideration in checking vertical creep. There is one very important fact to consider

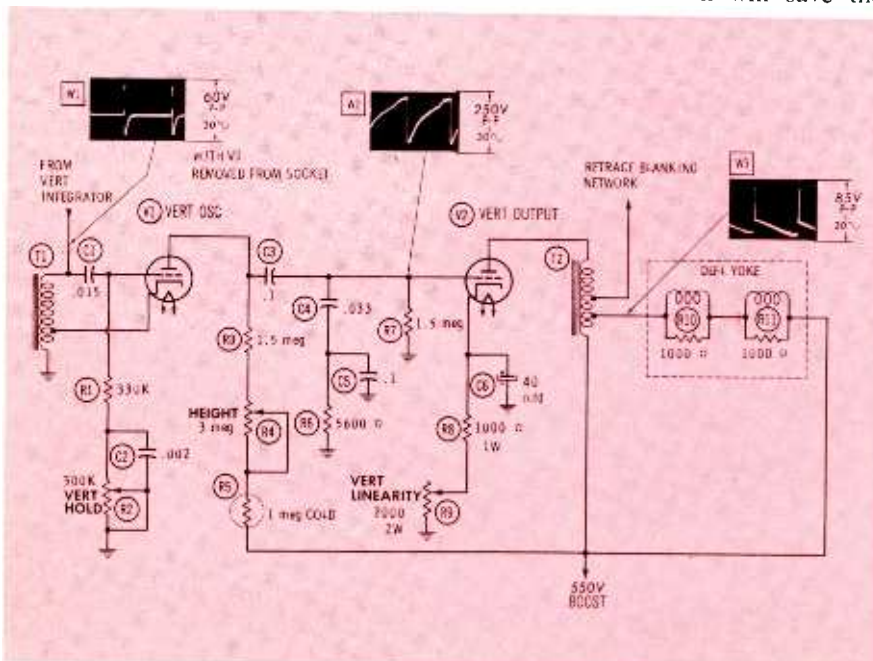

Fig. 1. Most causes of vertical creep are associated with the output stage.

about vertical sweep troubles that affect size and shape of the waveform: *Linearity* problems are almost invariably the result of shifts in DC operating voltage; on the other hand, faults that change the *height* of the picture usually affect signal voltages only, with little change in output-stage supply voltages.

This is why your scope is so helpful in pinpointing the cause of vertical creep problems. If the trouble happens to be one that doesn't affect DC voltages, you may find it difficult to get a clue with just the VTVM. But creep troubles all affect the waveshape in one way or another. By testing the effects of the vertical linearity and height controls on the waveform displayed on your scope, you can learn to detect which circuit is actually being affected by the creep symptom.

For example, take a close look at the waveforms shown in Fig. 2, taken at the output of the vertical transformer. Fig. 2A indicates the correlation between waveshape and the control functions: The height control affects the overall amplitude of the waveform, spike and all, while the linearity control has its primary effect on the sloping section of the trapezoidal waveform. Fig. 2B shows the same waveform after vertical creep has compressed the top of the picture; in Fig. 2C, the creep has affected only the height, so the entire waveform is lowered in amplitude.

Using the VTVM

Some servicemen prefer to try troubleshooting first with their VTVM or VOM. This approach will probably solve well over half of your vertical creep cases—if measurements are properly interpreted. In the other cases, you'll need a scope, or you'll have to use the time-consuming hit-and-miss method.

There are also two fallacies in using a VTVM in circuits with such

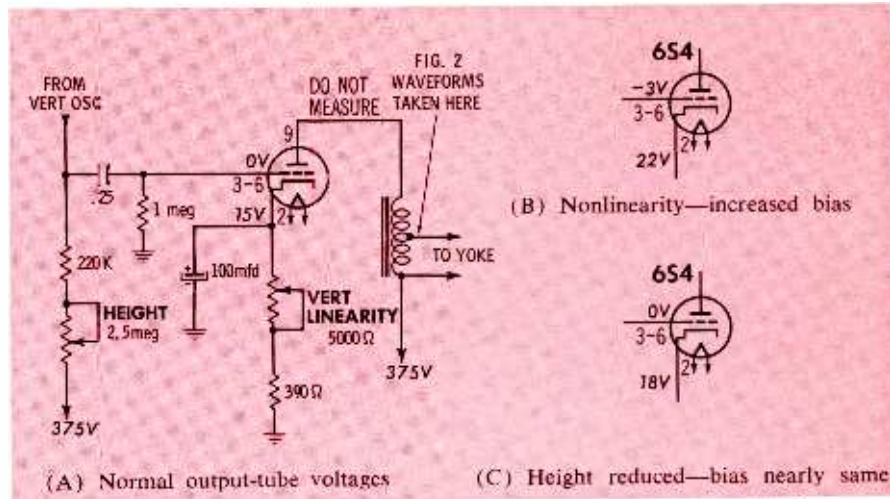

Fig. 3. DC voltages may or may not change as the vertical creep develops.

high transients as those found in the vertical output circuit: False DC readings are sometimes obtained through partial rectifying of high-amplitude signal voltages. And there's always the danger that a high-amplitude spike will exceed the input rating of the VTVM and damage the range multipliers. (This last danger exists with a scope, too, unless the input capacitor is one with a high breakdown rating.)

Fig. 3A shows a typical circuit marked with the voltages as they appear before vertical creep. (This is the same circuit in which the waveforms of Fig. 2 were taken, so you can correlate the symptoms seen on the scope with the voltage changes.) In Fig. 3B, vertical compression at the top of the screen has been caused by an increase in the bias developed across the cathode resistors, overbiasing the output tube. But in Fig. 3C, although creep has lowered the waveform amplitude to barely more than half its normal value, the cathode bias has shifted only slightly.

Practical Solutions

Unfortunately, cases of vertical creep are seldom so well defined as those just given. More often, the shift is very slight. It is very common for creep symptoms to appear

so gradually that the set owner doesn't even notice them until the fault becomes quite pronounced; if so, your job will be easier.

However, it is equally common for this culprit to become most noticeable a few days after you've cured some other complaint. The very nature of the brute—a slowly developing condition—tends to help it keep hidden while you service the set. If the set was on awhile when you made your service call, you probably made slight corrections with the controls and considered everything okay; but when the customer turned the set on the next day, he was unpleasantly surprised by having to wait an hour for the picture to assume full height or normal linearity.

If one of these "dogs" falls your way, don't waste time readjusting it and hoping for the best; pick it up and get it on your bench where you can monitor its actions. A customer who is unhappy at the idea of having the set gone for a few days will be even more unhappy (and so will you) if you have to come out to his house every few days to make adjustments. So get the set on your bench and do the job right to start with.

Besides the general techniques

•Please turn to page 88



(A) Normal input to yoke



(B) Top of raster compressed

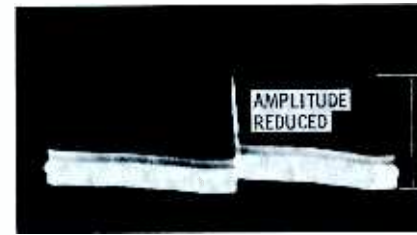

(C) Overall reduction in height

Fig. 2. Height and linearity changes have different effects on waveform.

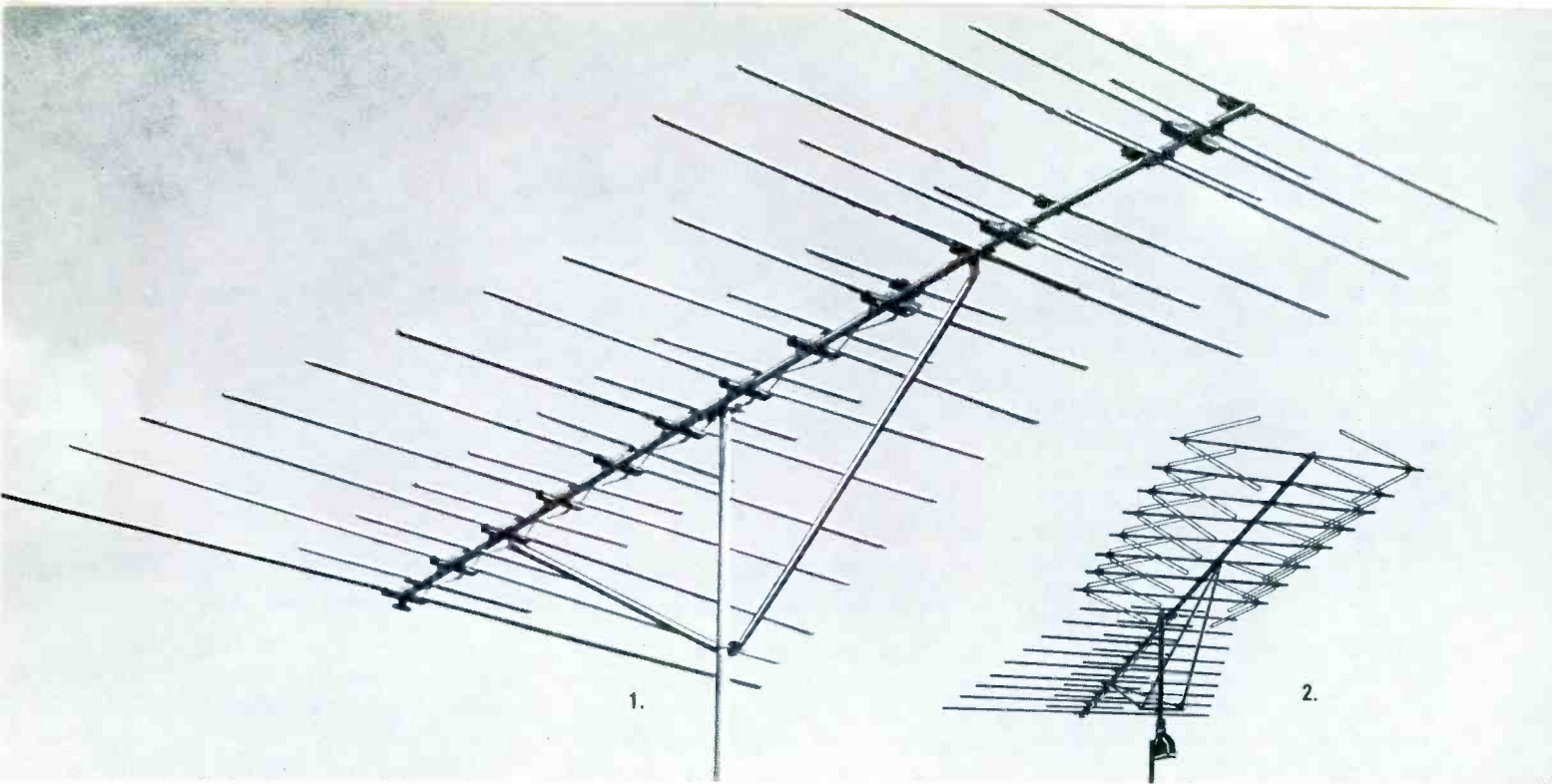

PICK YOUR MARKET! Nail it down

"CROSSFIRE"—MOST POWERFUL TV ANTENNA DESIGN IN THE FIELD!

1. GOLDEN CROSSFIRE 3600 Series

U.S. PAT. NO. 3,086,206 CONFIRMS AND PROTECTS EXCLUSIVE DUAL-DIPOLE SYSTEM—THE SYSTEM THAT STILL GIVES HIGHER, CLEANER GAIN (WITH LEAST BULK) THAN ANY COMPETITIVE ANTENNA! DOES IT AT LOWEST COST. EVEN INCLUDES FM! COMPETITIVE FRINGE ANTENNAS DON'T.

High-performance balance can be obtained only by using the right combination of both driven and parasitic elements. Only the Crossfire—with

its unique dual dipole system—has this power combination. The Crossfire patent protects this system—and no other antenna, old or new, can use it.

2. GOLDEN SUPER-CROSSFIRE Model 3607

The World's Most Powerful Antenna

1. Up to 48% more TV gain than 28-element Crossfire.
2. On FM Stereo... gives more gain than a 5-element yagi.

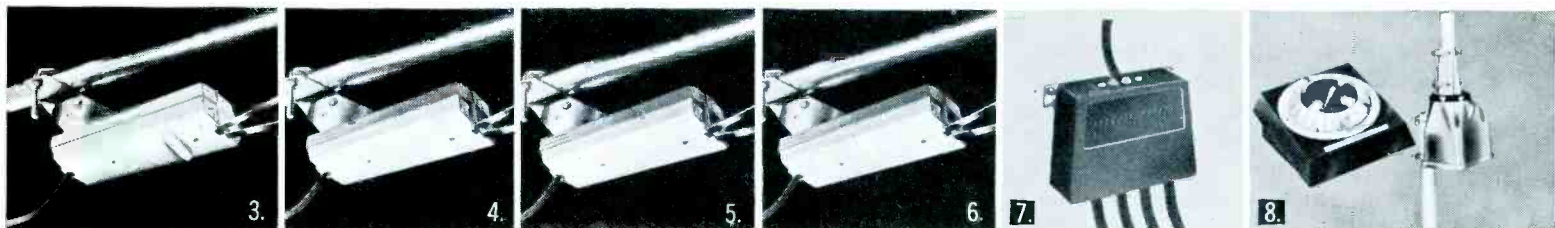

EXTRA-POWERFUL BOOSTERS THAT MEET EVERY NEED!

3. BRAND-NEW Nuvectorized "TV ONLY" TELE-VISTA Model 0026

YOUR MARKET: TELEVIEWERS IN AREAS WHERE BOTH TV AND FM STRONG SIGNAL OVERLOADING FROM NEARBY STATIONS IS A PROBLEM. The only "TV/only" Amplifier with the long-life "Duo Nuvector" circuit... and a built-in coupler! Strong local TV and FM signals won't overload it.

4. BRAND-NEW Transistorized "TV ONLY" TELSTAR Model 0027 with Built-In FM Trap... plus 4-set coupler.

YOUR MARKET: TELEVIEWERS IN AREAS WHERE FM STRONG-SIGNAL OVERLOADING FROM NEARBY STATIONS IS A PROBLEM. Twice the TV overload protection of any other transistorized booster... thanks to Texas Instruments' brand-new EPITAXIAL MESA TRANSISTOR. Virtually eliminates possibility of local FM interference.

5. TV/FM TELSTAR WITH 4-SET COUPLER Model 0023A

America's most outstanding, best-selling booster

YOUR MARKET: VIEWERS AND LISTENERS WHO WANT THE WORLD'S MOST POWERFUL BROAD-BAND AMPLIFICATION! Unbeatable Combination of High

Gain and Low Noise figure... plus built-in Lightning Resistance and other outstanding features.

6. TELSTAR FMX (for FM exclusively) WITH 2-SET COUPLER Model 0025

YOUR MARKET: THE EXPANDING NUMBER OF MONAURAL AND STEREO FM LISTENERS! Most powerfully stepped-up FM performance of all!

7. Improved! Higher Gain VUTRON II FOR TV/FM Model 0024

YOUR MARKET: THOSE WHO WANT THE BEST IN AN IN-THE-HOME SIGNAL AMPLIFIER AND COUPLER.

NOW FOR THE FIRST TIME... OUTSTANDING ALL-IN-1 ROTATOR AND TV AMPLIFIER!

8. GEMINI Model 9527

YOUR MARKET: THOSE WHO NEED AND WANT EXTRA POWER... PLUS DIRECTIVITY. Fast, neat installation saves money 4 ways! World's Finest Automatic Rotator (Tenn-a-liner)... plus Telstar TV booster. Built-in FM TRAP. Simple to Service. 2-set coupler.

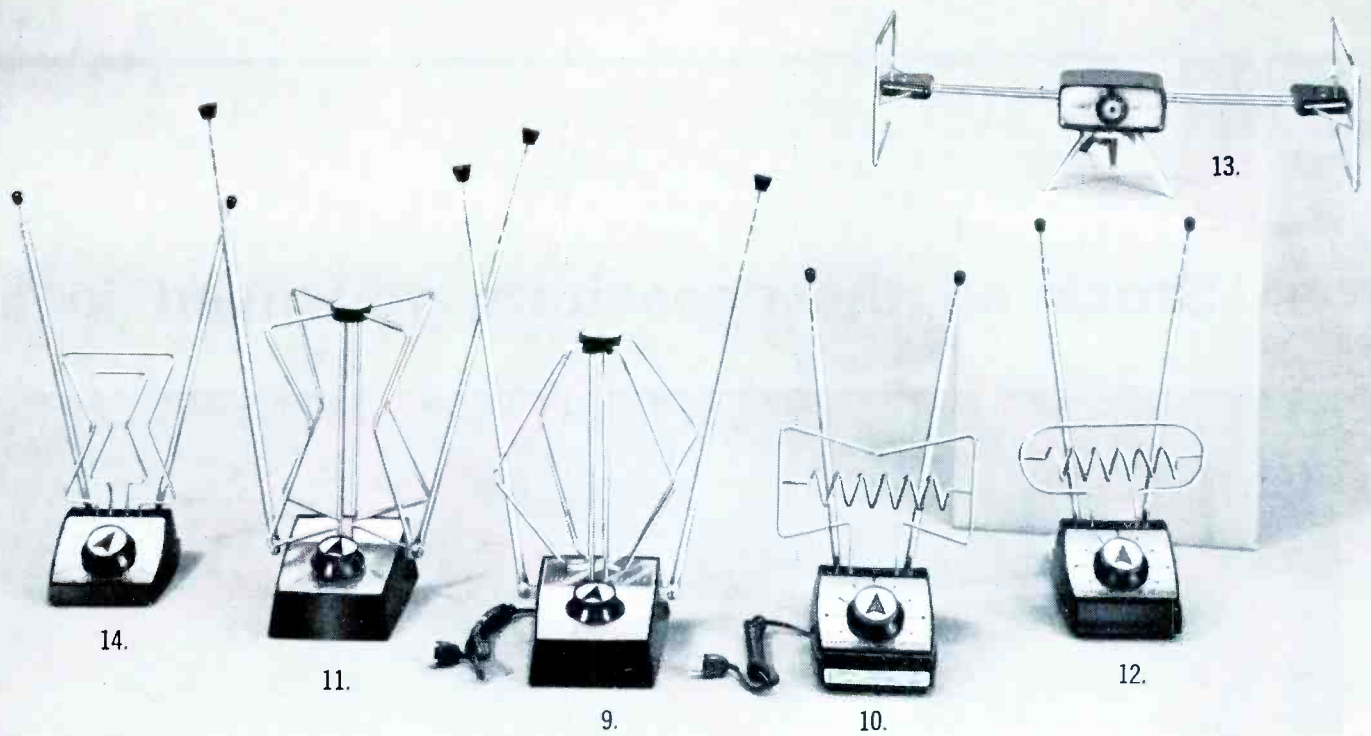

With **CHANNEL MASTER**

WORLD'S MOST POWERFUL NEW INDOOR ANTENNAS

These beautifully-designed antennas open a whole new market ... because they work where only outdoor antennas could work before!

9. NEW! Revolutionary, Transistorized **APOLLO** Model 3721 (with Built-in Amplifier)

GETS CLEAR, GHOST-FREE, TV RECEPTION 15 TO 45 MILES OUT.

YOUR MARKET: SUBURBAN VIEWERS WHO WANT OUTDOOR ANTENNA POWER FROM AN INDOOR ANTENNA. Exclusive "Miraclick" Switch electronically adjusts to different signal strengths. Super-effective hidden amplifier gives extra pull-in power where needed.

10. NEW! World's First Transistorized **FM/STEREO INDOOR ANTENNA with Built-in Amplifier.** Model 3731

GETS POWERFUL FM RECEPTION 15 TO 60 MILES OUT!

YOUR MARKET: SUBURBAN LISTENERS WHO WANT TOP FM PERFORMANCE WITH EASY ANTENNA ADJUSTABILITY AND ROTATOR-TYPE DIRECTIVITY. Booster is peaked—dipoles tuned—for FM exclusively! Fidelity Switch.

11. Golden **CANAVERAL** Model 3720 (Non-Amplified)

YOUR MARKET: METROPOLITAN AREA VIEWERS WHO WANT TOP TV/FM RECEPTION UP TO 15 MILES FROM STATION. Same features as Apollo.

12. NEW! **FM/STEREO INDOOR ANTENNA** Model 3730 (Non-Amplified)

YOUR MARKET: METROPOLITAN AREA LISTENERS... WHO SEEK FM PERFORMANCE WITHOUT COMPROMISE! Same advance features as 3731.

13. Improved! **SHOWMAN** Model 3900 (Mahogany and Gold) Model 3901 (Blond and Gold)

YOUR MARKET: CUSTOMERS WHO WANT SOMETHING DIFFERENT! Beautiful ... improved... priced to move! "Metro-Dyne" Variable Inductance Electronic Tuning. Like no other antenna.

14. NEW! **AURORA** Model 3718

YOUR MARKET: THOSE WHO WANT A LOW-PRICED LUXURY ANTENNA! Tops for the money! Magnificently styled. "Automatic" Clarifier Switch.

FREE GIFTS! SEE YOUR CHANNEL MASTER DISTRIBUTOR FOR FULL DETAILS ON INDOOR ANTENNA PREMIUM DEAL.



NEW! BEAUTIFUL, POWERFUL "VU-CON" UHF CONVERTERS

GIVE YOU THE EDGE IN EVERY RECEPTION AREA ... NOW AND IN THE FUTURE!

15. Model 6700. **YOUR MARKET:** FRINGE-AREA LISTENERS WHO WANT THE ULTIMATE IN RECEPTION. Capacitive tuning (no sliding contacts), 1 long-life Nuvistor, 1 oscillator tube. Prevents strong-signal overloading.

16. Model 6701. **YOUR MARKET:** FRINGE-AREA LISTENERS WHO WANT

TOP QUALITY AT A MODERATE PRICE! Inductive Tuning, 2 long-life Nuvistors.

17. Translator Model 6703. Same as above but covers only channels 70-83.

18. Model 6702. **YOUR MARKET:** METROPOLITAN AND SUBURBAN AREA LISTENERS WHO WANT TOP QUALITY AT A MODEST PRICE! Your most profitable UHF conversion market. Inductive Tuning, 1 long-life Nuvistor.

19. Translator Model 6704. Same as above but covers only channels 70-83.

Circle 79 on literature card

CHANNEL MASTER CORP., ELLENVILLE, NEW YORK

www.americanradiohistory.com

A FEW
WILL DO

Stock all the capacitors you need in a

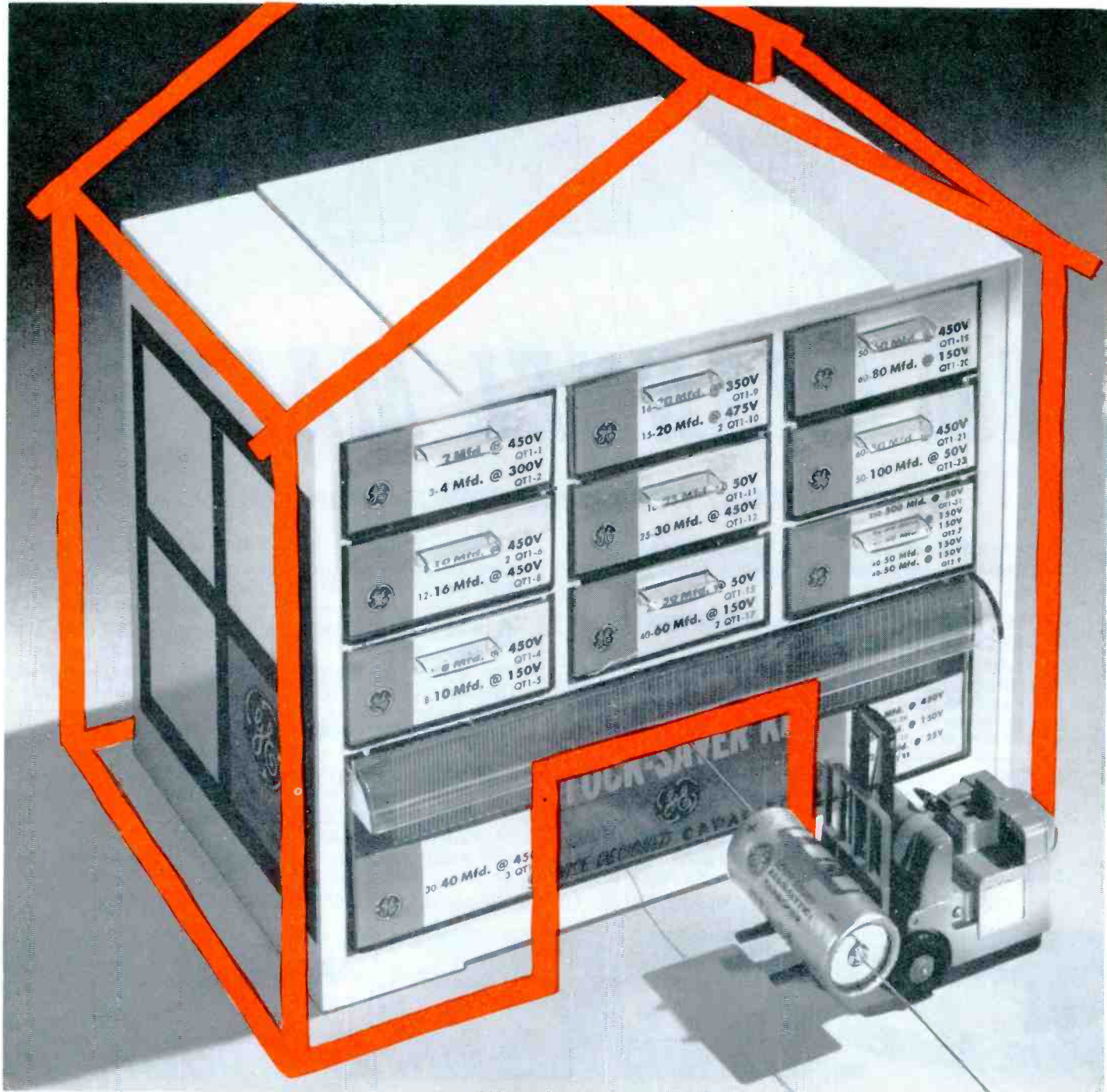

ANOTHER ACCENT ON VALUE FROM YOUR

pint-size warehouse

This small warehouse is stocked with enough capacitors to meet most of your replacement needs. We call it a Stock-Saver Kit because, on the average, one G-E capacitor replaces four types.

Before G.E. developed Stock-Saver Capacitors, it was practically impossible for you to keep a supply in your shop. It tied up too much money. But G.E. found a way to replace more than 150 different types with only 25 capacitors. This makes it possible for you to select the most-needed types and keep a supply on hand. The cost is low because *a few will do*. To make it even more convenient and profitable for you to use G-E capacitors, we have built selected stocks and put them in attractive storage units. You pay only for the capacitors . . . there's no charge for the pint-size warehouse. These kits will save you the cost of single-unit ordering . . . not to mention pesky trips for emergency pickups.

G-E ELECTRONICS DISTRIBUTORS

FOR A LOW-COST START, WE'RE MAKING YOU THIS SPECIAL OFFER

BUY ONE OF THESE...

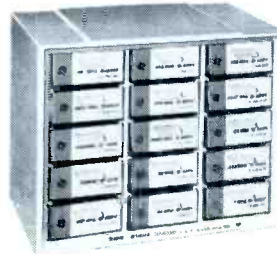

KIT K-415

Contains 108 of 15 popular ratings of paper-mylar type capacitors.

List Price

Capacitors \$33.42
 Kit 4.98
VALUE 38.40
 Your cost, complete, only \$19.92



KIT K-100

Contains 19 electrolytic tubular units in the 14 most popular ratings.

List Price

Capacitors \$30.00
 Kit 4.98
VALUE 34.98
 Your cost, complete, only \$17.95

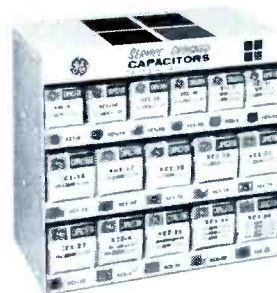

KIT K-201

Contains 16 most popular electrolytic and twist-prong types.

List Price

Capacitors \$50.00
 Kit 5.00
VALUE 55.00
 Your cost, complete, only \$29.95



KIT K-202

Contains 10 twist-prong capacitors designed for auto replacement. In addition you get a magnetic service light, a tab adjuster and a handy auto replacement guide.

List Price

Capacitors \$33.30
 Service aids 3.25
VALUE 36.55
 Your cost, complete, only \$19.98

AND GET THIS ONE FREE...\$7.75 VALUE



This kit is a handy top-opening type . . . just the right size for carrying in your tool or tube caddy. It contains 21 of the five most popular paper-mylar ratings. This \$7.75 value is yours at *no extra charge* when you buy one of the shelf-type kits shown above.

SEE YOUR GENERAL ELECTRIC DISTRIBUTOR TODAY!

THIS OFFER EXPIRES OCTOBER 31, 1963

Progress Is Our Most Important Product

GENERAL  ELECTRIC

Circle 17 on literature card

audio clippers in communications

by Edward M. Noll

Audio clippers have two important assignments in communications gear—as modulation limiters in the transmitter and as noise clippers in the receiver. Although their purposes are quite different, modulation limiters and noise clippers are often quite alike in circuit arrangement.

The purpose of a modulation limiter is to clip off voice-signal peaks so a higher average level of modulation can be maintained. This increases the average level of demodulated audio at the receiver, raises the intelligibility of the signal, and increases the reliable transmission range. On the other hand, the purpose of the audio clipper in the receiver is to help remove noise from the demodulated voice signals, especially strong impulse noises such as those generated by vehicular ignition systems. It is these noise-clipping circuits of communications receivers we will analyze in this article.

Clipper Action

Some clipper circuits have no adjustment. Others include controls that can actuate or disable the circuit, or adjust the level of clipping. Such adjustment is sometimes necessary, because it is possible for a noise-clipper stage to hamper the response of the receiver to a weak signal or—at the other extreme—to distort a strong signal.

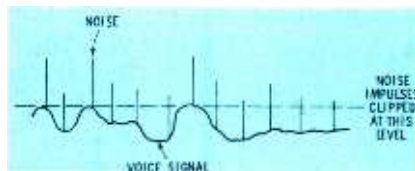

Fig. 2. Noise pulses "riding" above voice signals are removed by clipper.

Although the basic audio-clipper circuit (Fig. 1) looks like a half-wave rectifier, it must respond to the peaks rather than the average level of the signal—since a receiver noise clipper must affect only impulse noises that are higher in amplitude than the peak level of the desired signal (Fig. 2).

Peak-clipping can be accomplished by the use of either self-bias or external bias. The effect of biasing the rectifier circuit is shown in Fig. 1B. The anode of the diode is positive with respect to its cathode, so the diode normally conducts. When an audio signal is applied to the cathode, the diode current tends to follow the signal variation, developing the signal across the load resistor. The level of the input signal is insufficient to swing the cathode positive at any time; thus, the signal is not rectified, but is merely coupled through the diode.

However, a very strong noise pulse will have an amplitude greater than the diode bias. When such a pulse occurs, the cathode will be driven positive with respect to the

plate, and the diode will not conduct. As a result, the noise peak will not be developed across the output resistor; therefore, it will be clipped off the output signal. The level at which clipping occurs is determined by the diode bias.

It is significant that the simple diode circuit of Fig. 1B can clip only positive noise peaks from the applied signal. In most cases, there are also negative pulses that should be removed. Just as two rectifiers can be made to rectify both positive and negative portions of a sine wave in the secondary of a power transformer (full-wave rectifier), an arrangement of two diodes can be used to clip both positive and negative noise peaks.

A Practical Clipper

A noise clipper circuit that is used widely in two-way radio receivers is shown in Fig. 3. The two diodes are in series with the signal path between the demodulator and the gain control of the first audio amplifier. When the noise limiter is switched on, the plates are grounded through R4 and R6. Cathode bias is developed across resistor R1 and in bleeder network R2-R3. The negative voltage across R1 varies with the strength of the incoming signal, and opposes the positive voltage from the bleeder chain. When a signal is received, the net cathode bias is negative. The two diodes conduct, presenting a low-impedance path from the demodulator to the volume control via capacitors C2 and C3.

When a strong negative noise pulse appears across resistor R4, it makes the plate of V1 negative for the duration of the pulse, and the noise peak can't pass through. The clipping action therefore reduces all noise pulses to the level of the accompanying audio signal. Even though it is not completely eliminated, the noise is made far less annoying in the receiver output.

Any positive noise pulse is passed through diode V1 and is developed across resistor R5. However, the positive pulse on the cathode of V2 stops conduction, thus blocking the strong noise peak from reaching the volume control. This use of two series diodes thus permits clipping both positive and negative noise spikes that are above the level of the demodulated audio.

●Please turn to page 84

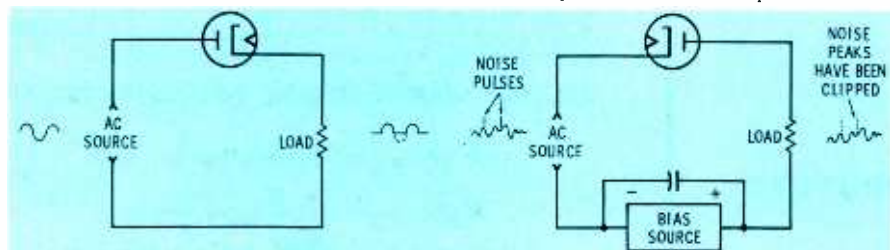

(A) Simple rectifier
Fig. 1. Noise clippers bear a strong resemblance to ordinary rectifiers.

The Revolution Is Growing

NEW LOG PERIODICS WILL FURTHER DEMOLISH EXISTING ANTENNA CONCEPTS.

One year ago, JFD introduced the LPV antenna based on the patented new log periodic formula of the Antenna Research Laboratories of the University of Illinois.

Television (and FM) reception hasn't been the same since.

This revolution that changed the course of antenna history is gathering greater momentum. Our Research and Development Antenna Laboratories in Champaign, Illinois has just released several entirely new Log-Periodic television and FM antenna designs for production.

The first of this exciting new generation of JFD Log-Periodics will bring to UHF, even more so, the same superb frequency-independent reception qualities that are working such wonders in VHF. The new UHF Log-Periodics will consist of two

antenna groups of three models each, and one UHF Indoor Log-Periodic. These dramatic new antennas will give you the flexibility you need in sensitivity and directivity to overcome the problems inherent in UHF signal behavior.

And if you're entering the rocketing FM stereo market, you can expect a solid boost from JFD in the form of new Log-Periodic antennas designed expressly for multiplex stereo.

Whether you are buying VHF, UHF, or FM antennas, we invite you to compare before you specify. Because after all is said and done about any antenna—at the moment of truth, the picture is the proof. Use, sell and install JFD Log-Periodics based on the formula discovered and patented by the Antenna Research Laboratories of the University of Illinois, and adapted for TV and FM by the JFD R & D Laboratories in Champaign, Illinois. See the difference it will make in your profits, performance and prestige.

JFD ELECTRONICS CORPORATION

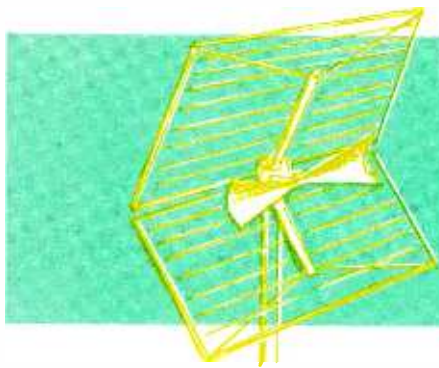

UHF Antennas

NEW BOOM AHEAD

Good antennas are the key to success of all-channel reception . . . by Forest H. Belt

Just a few short months from now, in April of 1964, the new all-channel receiver law will go into effect. In most localities, this will cause little immediate change, but the law is eventually going to have some far-reaching consequences.

The effect will be felt first in certain areas around the country where UHF stations are already operating in competition with VHF. Viewers who buy sets in these localities frequently have refused to pay the additional price for a UHF converter or antenna, when they could have *some* TV without any extra cost. Beginning in April, however, all new sets will be coming through equipped with UHF converters, in compliance with the law; this will remove the next-to-last barrier to general acceptance of UHF in these areas.

One hold-back that has plagued UHF is the reluctance of would-be station owners. Because UHF doesn't cover quite as wide a service area as VHF, investors feel they are operating at a disadvantage. Further, the extra cost involved in adding UHF reception to existing VHF television receivers has deterred consumers from making the change, and this has compounded the situation. As a result, hardly anyone wants to build UHF stations, and many excellent possibilities for additional programming and other facilities are being bypassed. At present, there are only a few more than 100 UHF stations in operation, and a number of these are educational stations. The All-

Channel Receiver Law was introduced and passed in hopes of removing at least one of the roadblocks to better utilization of the nearly empty UHF TV spectrum. If all goes as planned, next year many more station builders will "take the plunge" into UHF.

Meanwhile, servicemen all over the country need to become aware of the possibilities that are opening up for them. Most important of these is the antenna business, which will be an important part of this increased UHF activity. In many areas of the country, after April, a good UHF antenna installation will be the only item necessary to bring many added hours of TV programming into homes with modern receivers. You may well be fortunate enough to live in one of these areas, so you'll want to read this article carefully, and remember some of the pointers we're going to give you concerning UHF antennas.

Simpler Than VHF

Yes, compared with installing VHF antennas (which can get complicated and bulky), putting up a UHF antenna is going to be duck soup. Many shops which now farm out their antenna work will be getting back into the antenna-installation business, primarily because of the simplicity and convenient size of the UHF antenna.

But don't become overconfident; there are some things you should know first. For example, certain techniques of installation are very important when you're dealing with UHF. Many of these special considerations should have been used with VHF all along, but station signals strong enough to compensate for shortcomings of the receiving antenna have been plentiful in most areas; as a result, we may have come to take just a little too much for granted. With UHF, though, you'd better start polishing up your workmanship. Signal losses sometimes amount to hundreds of times as much as in VHF, and there is little room for haphazard installations. It's the careful technician who will have the most success with UHF.

But even with these extra considerations, UHF installations will be inherently more simple than VHF installations under comparable conditions. So let's get on to the heart of the matter—the UHF antenna.

How Far Away?

When you consider UHF reception, you will have to alter your thinking somewhat from that which applies

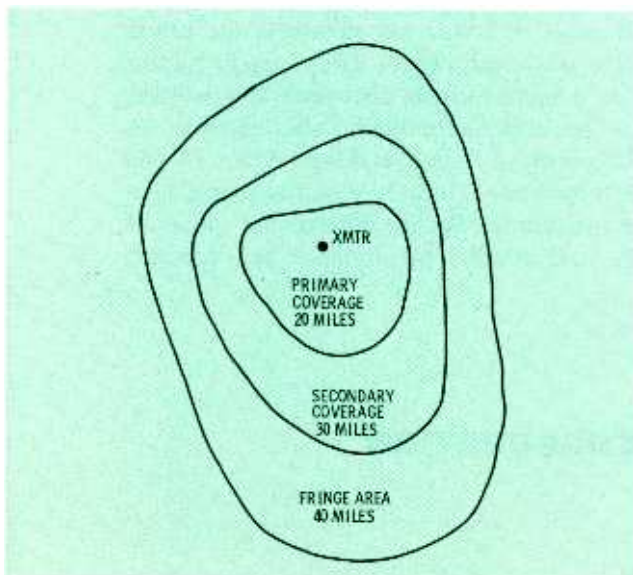

Fig. 1. Station patterns indicate reception vs. distance.

NOW EVERYONE CAN QUICKLY Set up and Service Color TV



1 PATTERN DISPLAY STANDARD
Shows correct pattern in window viewer for visual guide

2 PATTERN SELECTOR
Produces each pattern individually for quick, easy convergence

3 AUTOMATIC DECONVERGENCE
Simplifies static and dynamic convergence. No digging into set

4 COLOR SELECTOR
Produces each color one at a time for accurate color set-up

5 COLOR GUN KILLER
Automatically enables the technician to actuate any combination of the 3 guns

6 DEMODULATOR ALIGNMENT
Makes alignment extremely simple, without going into the color set

New! **B&K** Model 850 **COLOR GENERATOR**

*Most Complete, Most Versatile, Portable Instrument for Use in the Home and in the Shop
Makes Color TV Set-up and Service Easier, Faster than ever!*

Now every service technician can be ready to set-up and service color TV with amazing new ease and speed! New advanced design simplifies the entire operation, saves time and work in every installation. Eliminates difficult steps in digging into the color TV set. Gives you new confidence in handling color.

Produces Patterns, Burst, and Colors Individually—Provides dot pattern, crosshatch, vertical lines, horizontal lines, burst signal, and individual colors—one at a time—on the TV color set—for fastest, easiest check. Unique window-viewer on front of the instrument panel shows you each pattern as it should be—gives you an exclusive display standard to use as a sure guide for quick, visual comparison.

Provides Accurate, Individual Color Display—Produces Green, Cyan, Blue, B—Y, Q, Magenta, R—Y, Red, I, Yellow, and Burst—one at a time. All colors are crystal-controlled and are produced by a precision delay-line for maximum accuracy. Each color is individually switch-selected—no chance of error.

Provides Accurate NTSC-Type Signal—Color phase angles are maintained in accordance with NTSC specifications.

Makes Convergence and Linearity Adjustments Easy—Highly stable crystal-controlled system with

vertical and horizontal sync pulses, assures the ultimate in line and dot stability.

Simplifies Demodulator Alignment—The type of color display produced by this instrument provides the ultimate in simplicity for precise demodulator alignment.

Provides Automatic Deconvergence—Eliminates the necessity for continual static convergence adjustments. The instrument automatically deconverges a white into a color dot trio without digging into the color set to mis-adjust the convergence magnets. It also deconverges a white horizontal or vertical line into red, green and blue parallel lines. This greatly simplifies dynamic-convergence adjustments.

Provides Exclusive Color Gun Killer—Front-panel switch control makes it easy to disable any combination of the three color guns. Eliminates continuous adjustment of the background or screen controls, or connection of a shorting clip inside the receiver. The switch also selects the individual grids of the color tube and connects to a front-panel jack to simplify demodulator alignment.

Provides Switch-Selected R.F. Signals—Factory-tuned, for channels 3, 4, and 5—for open channel use in your area.

Model 850 also includes other features that make it invaluable for home and shop use. Net, \$199⁹⁵

See Your B&K Distributor
or Write for Catalog AP21-R



B & K MANUFACTURING CO.

Division of DYNASCAN CORPORATION

1801 W. BELLE PLAINE AVE. • CHICAGO 13, ILL.

Canada: Atlas Radio Corp., 50 Wingold, Toronto 19, Ont.

Export: Empire Exporters, 253 Broadway, New York 7, U.S.A.

Circle 19 on literature card

October, 1963/PF REPORTER 47



There's a Philco Tube or genuine Philco part that is "right" for any replacement job. But more important, every one has the same common denominator that is your guarantee of satisfaction . . .

"QUALITY"

All material and parts used in the manufacture of Philco 20/20 Star Bright CR Tubes are new except for the envelope, which prior to reuse, has been inspected and tested to the same standards as new envelopes.

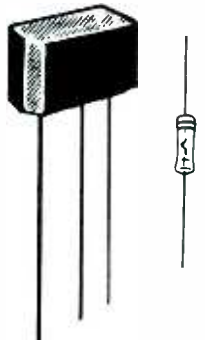

PHILCO DIODES

A complete selection of diodes for exact replacement, including IN34, IN64; and Dual Diodes P15, common cathode (replaces Fed. K1615 and IRCD4); P16 series connected (replaces Fed. K1616 and IRCD5) and P17 common anode (replaces Fed. K1617 and IRCD6).

HI-DENSITY 500 MIL Selenium Rectifier and 500 MIL Silicon Cartridge Rectifier
Top quality products, perfect replacements for original equipment.

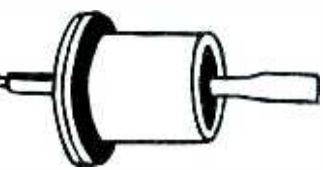

GUARANTEED 500 MIL SILICON RECTIFIER

Ideal for general replacement and miniaturization purposes. Lower voltage drop gives more drive plus greater anode voltage.

YOUR PHILCO DISTRIBUTOR

Features These Famous Brand Parts and Accessories

- PHILCO
- EVEREADY Batteries
- FLASHLIGHTS
- CAROL CABLES
- GOODRICH V-Belts
- GC Products
- AUDIOTEX
- WALSCO Products
- TELCO Antennas
- PRECISION Test Equipment
- PACO Kits

to VHF. Fig. 1 gives some idea of how UHF reception can be classed according to distance. Tests and experience have proved that UHF stations, given sufficient power and a good frequency at the low end of the band, have prime-signal areas roughly similar to high-band VHF—about 20 miles. Beyond this, however, UHF has its own characteristics; so let's just ignore VHF, and consider UHF on its own merits.

The near-fringe UHF areas lie between 20 and 30 miles from the transmitter. This is the locality where antennas with higher gain begin to be necessary, and you will find some very special reception conditions. Up to 40 miles, and sometimes 45, rather dependable results can be obtained with the proper antennas; however, there are certain types of terrain which make reception a bit touchy, and require careful attention to all aspects of the antenna installation.

Beyond 50 miles, UHF reception must be classed as far-fringe; acceptable reception depends on the use of high-gain antennas, carefully located, and installed with the utmost consideration for minimizing losses. There are a number of localities that now enjoy very satisfactory UHF reception from 60 and 70 miles away, but the stations are powerful, are located on high ground with tall antenna towers, and have frequencies near the lower end of the UHF-TV band. In addition, the receiving towers are high, and the antennas are special high-gain types designed for such long-range reception.

As you have undoubtedly surmised from all this, there are several different types of UHF antennas. Which ones should you choose for which locations? Let's consider each reception area and discuss how we can overcome the problems that might arise in each.

Just Like Downtown

The UHF tests in New York, conducted last year at the request of the Federal Communications Commission, seem to indicate that prime-area reception has few problems that are any different from VHF. Experience among servicemen around the country has, however, pinpointed a few situations that demanded some rather unusual adaptations. More important, experience in New York and elsewhere has indicated the wisdom of learning the characteristics of different antenna types, for each has special characteristics that make it especially suited for one application or another.

Indoor Types

Indoor antennas for UHF are a bit different from those for VHF. Although the ordinary rabbit-ear VHF antenna has been used with fair results in many localities, the special UHF indoor antennas are less likely to introduce ghosts and intermittent fading of the signal.

The most common of these is the "halo," a flat ring of metal several inches in diameter. Like all indoor UHF antennas, this unit is a broadband type; its only serious disadvantage is lack of directivity.

Indoor bow-ties, with flat reflectors, are available for the downtown installation that is troubled by ghosts. The grids of the reflectors are often styled in very attractive patterns, so the customer doesn't object to having the antenna sitting on top of a TV console. A somewhat similar reflector-type indoor antenna uses

IT'S HERE!

*The Only Indoor
TV Antenna
Engineered for the
Service Technician*



THE EXTRAORDINARY

GALLO

TWIN TV ANTENNA

Forget roof-climbing! No tiresome orienting of antennas to produce a proper signal. Forget lots more troubles, too — with the extraordinary GALLO TWIN TV ANTENNA, hit of the Chicago Parts Show and a smash sales hit everywhere it's been introduced!

The GALLO TWIN has *everything* you could ask for as a service technician. But don't take our word for it. *Seeing is believing.* Ask your own Distributor to let you hook up this amazing indoor antenna to *any* set—console or portable, UHF or VHF, B&W or color—anywhere within about 40 miles from the transmitter. See it produce the finest signal of any indoor antenna and equal many outdoor units. No dangerous protruding rods, no awkward adjusting and positioning between stations.

This 7" x 9" x 1" beauty goes anywhere, standing on its own easel or hung on the wall like a picture. Matches any set you sell or service *electronically* with its patented two-antennas-in-one design. Ask your Distributor or write for details now.

A
Personal Message
from
Carl Gallo,

*President,
Gallo Electronics Corp.
Formerly Director of
The Lincoln School
of Radio and Television*



The new GALLO TWIN TV ANTENNA was developed in our laboratories to meet the needs of the Service Technician for an antenna that is quick and easy to install, performs with any set, needs no selling because of its beauty, safety, convenience and efficiency. Having trained over 10,000 Technicians in recent years, I believe I know that no other indoor TV Antenna offers you so much help in your day-by-day work of keeping your customers satisfied.

GALLO ELECTRONICS CORP., 12 Potter Avenue, New Rochelle, N. Y.

Circle 21 on literature card

October, 1963/PF REPORTER 49

**FOR THE
GOLDEN AGE
OF COLOR TV
THE ALL NEW**

**TRIO® Golden Zephyr VHF
COLOR-BRITE UHF ALL-CHANNEL ANTENNAS**

with a written GUARANTEE!
offer: • IMPROVED PERFORMANCE! • IMPROVED
CONSTRUCTION! • IMPROVED APPEARANCE!
... OVER ANY OTHER TV ANTENNA OF EQUIVALENT SIZE AND TYPE
... REGARDLESS OF THAT ANTENNA'S MAKE OR PRICE!

Yes! There's a written guarantee packed with each new TRIO antenna! Where conventional VHF antennas fail, you'll find TRIO's patented — and exclusive — WING DIPOLE, WING DIRECTOR and DYNACOIL PHASING capable of assuring complete customer satisfaction . . . for both COLOR and Black and White TV!

For UHF, there's no beating the TRIO COLOR-BRITE! Proved by independent engineering research **dollar-for-dollar** THE MOST POWERFUL UHF COLOR TV ANTENNA TODAY!

**BIGGER PROFITS!
ASSURED CUSTOMER SATISFACTION!
WITH THESE EXCLUSIVE TRIO FEATURES:**

no-strip Lead-in Connector — Stops Broken Leads at the Antenna!

Insta-Lok Element Clamps — Eliminate Roof-top Assembly!

TGP (TRIO GOLDITE PROCESS) — Unique TRIO Golden Finish Replaces Anodizing to Protect The Entire Antenna From Corrosion!

TRIO's Guarantee of Performance and Quality is YOUR Guarantee of Profits!

**TRIO GOLDEN ZEPHYR • TRIO COLOR-BRITE
BEST FOR THE GOLDEN AGE OF COLOR!**

A TRIO EXCLUSIVE!



**PATENTED NO-STRIP
LEAD-IN CONNECTOR**

NO STRIPPING!
NO SOLDERING!
NO EXPOSED WIRE!
NO BROKEN WIRES AT THE ANTENNA!

EXTRA VALUE AT NO EXTRA COST!



TRIO® MANUFACTURING COMPANY, GRIGGSVILLE, ILLINOIS

Circle 22 on literature card

200,000 OHMS PER VOLT

TRIPLET



Model 630-NS
VOLT-OHM-MICROAMMETER

\$99.50
SUGGESTED U.S.A. USER NET

NEW AND THE FIRST

TRIPLET SUSPENSION MOVEMENT

*no pivots . . . no hair springs
no jewels . . . thus NO FRICTION*

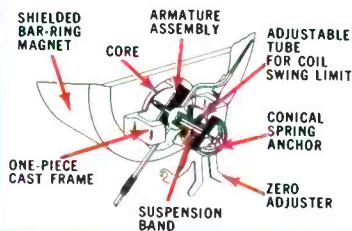

FACTS MAKE FEATURES:

- 1** 200,000 OHMS PER VOLT D.C. for greater accuracy on high resistance circuits. 20,000 OHMS PER VOLT A.C.
- 2** 5 μ SUSPENSION METER MOVEMENT. No pivots, bearings, hair-springs, or rolling friction. Extremely RUGGED. Greater sensitivity and repeatability.
- 3** 62 Ranges, usable with frequencies through 100 Kc. Temperature compensated. 1½% D.C. ACCURACY, 3% A.C.

Low voltage ranges and high input impedance make the 630-NS especially useful in transistor circuit measurement and testing. Input impedance, at 55 volts D.C. and above, is higher than most vacuum tube voltmeters.

The unit is designed to withstand overloads and offers greater reading accuracy. Reads from 0.1 μ a on 5 μ a range. Special resistors are rigidly mounted and directly connected to the switch to form a simplified unit. Carrying cases with stands are priced from \$9.90.

TRIPLET ELECTRICAL INSTRUMENT CO., BLUFFTON, OHIO

Circle 23 on literature card

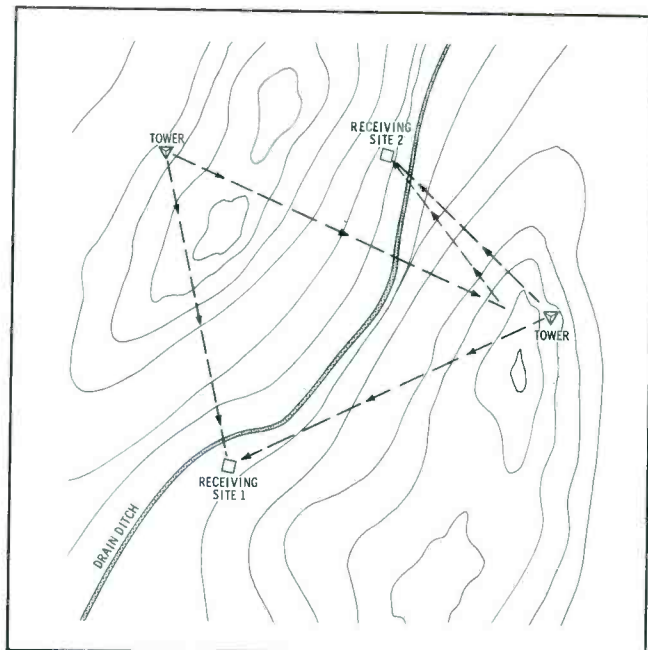

Fig. 3. Contour map will help solve reception problems.

Suburbia

As you move into the region beyond 20 miles, you'll find it necessary to recommend some sort of antenna with more gain than the ordinary bow-tie. A simple antenna may work okay part of the time, but for most dependable reception, a higher-gain unit is a must.

In this area, too, you may be troubled by ghosts if there are many hills close by. However, the antennas with higher gain also generally show a narrower forward lobe in the polar pattern; thus, it is easier to orient the antenna to eliminate ghosts.

You may find it wise to use a UHF field-strength meter and an easily carried antenna to "probe" for the best receiving location at each installation; most areas are not unduly critical, but sometimes a few feet will make all the difference in the world in signal reception. Be sure you don't cause exasperating complications for yourself by inadvertently mounting the antenna in a dead spot!

Multiple Bow-Ties

By far the most popular antenna for near-fringe installations is the four-stacked bow-tie with a screen reflector. Almost all manufacturers provide a unit of this type in their lines, because of its proven popularity with installation technicians.

The bow-ties used with these units vary considerably in design, and a few use rod-type reflectors instead of a screen. All are characterized by good gain, a reasonably narrow pickup pattern, and a good front-to-back ratio. This latter quality is sometimes necessary if a hill is nearby on the opposite side of the receiving site from the UHF station.

Bow-ties used include the flat metal types, wire "X" types (sometimes termed "catwhiskers"), and cardioid-shaped wire types.

Yagis

In some near-fringe localities — primarily where ghosts are a serious problem—the extra gain and nar-

●Please turn to page 74

As you read this ad . . .
A Finco Engineer is designing
A "special area" TV Antenna
Finco has produced 3,152 already
Each one is the best in its area
Want proof?
See your Finco distributor
Or write us.



Circle 24 on literature card

PROFITS



from PA systems

by Len Buckwalter

Many service shops feel shut out of the PA business. Long before ground is broken for a new school in the community, its sound system is under contract. Or the opening of a nearby shopping center reveals an elaborate multispeaker sound installation. This is the kind of lucrative PA business that has remained just beyond the reach of the small radio-TV shop. The field of industrial sound is often quite involved, requiring the submission of bids, working with architects and engineers—plus plenty of know-how and financial capability.

But this is only one view of the PA field, and a narrow view at that! Like air conditioning, the public-address system has made the transition from big-business luxury to the realm of basic necessity in numerous modest applications. Exploiting these lesser opportunities can both increase profits for a small shop and provide the valuable experience needed to crack the bigger installations later.

A huge amount of untapped PA business exists. One enterprising technician armed himself with a half-dozen simple PA units and made a "cold-turkey" canvass of several stores in a busy shopping district. The response was amazing. Within a matter of hours most of the units were sold, installed, and in operation.

His experience points up some significant features of the PA field. While most persons have seen units in operation, they fail to visualize its potential benefit to their own business. Their lack of a PA system does not necessarily create a distress situation; it's only *after* the equipment is installed that the user wonders how he ever got along

without it! The picture you want to present to a prospect is that, whether the system is used to announce a lower price on strawberries in a busy supermarket, or on a used-car lot to summon a salesman, PA is a proven labor-saving device that will more than pay its own way if given the chance.

Familiar Territory

The service shop entering the PA field is not treading on wholly uncertain ground. Much of the routine troubleshooting performed in the audio circuits of TV and radio is identical to that required in PA equipment. The same basic theory, test equipment, and repair techniques can serve the technician just as well in both fields.

Like hi-fi, PA is simply another degree of specialization in the familiar field of audio. The key differences are in amplifier power and the problem of efficient distribution of audio power over relatively long lines. As the technician becomes familiar with the jargon of PA, he will learn about re-entrant horns, constant-voltage lines, and L-pads. He will use charts which show how much power is lost, for example, in a No. 18 wire running to a speaker located 200 feet from the main amplifier, and what the high-frequency loss is in 500-ohm line. These fundamentals may be unfamiliar at first, but are readily absorbed and understood by virtually anyone who has the ability to service home-entertainment equipment.

Finding Buyers

While the purely technical side of PA is a logical extension of basic audio, the business aspect introduces some elements of its own that may be unfamiliar. First, the

service shop must now sell products as well as service. Fortunately, there is little need for a significant inventory; PA equipment is usually ordered to suit the particular job. There is no need for the customer to choose from a lavish display of amplifiers, speakers, or microphones; in fact, the customer is apt to be unfamiliar with even the leading manufacturers. He is more interested in performance and expects to receive reliable, commercial-type units that can serve his requirements with least care.

Exposing the user to the product involves promotional effort which is, in certain respects, specialized. Not all persons are prospects for a PA system, so a concentrated effort is usually most fruitful.

A rich source of leads is in new construction. Access to this activity is not especially difficult. In smaller towns the local newspaper often publishes the names of firms that have filed for building permits in the area. In heavily populated regions, the same information is frequently available from companies specializing in a regular subscription service. When your PA business is large enough, this method is superior to newspaper notices in that information is considerably more detailed. Besides a new company's name, address and telephone number, the report states the nature of the business, square footage, and even some idea of its financial condition.

Other ways of gathering leads are by direct mail, personal visits, and an ad in the yellow pages of the telephone directory. A working relationship with local building contractors and architects, sometimes through their associations, is a val-

Find it and Fix it in 1/2 the time!

EASILY SOLVES "TOUGH DOGS"... INTERMITTENTS... ANY TV TROUBLE



MODEL
1076

TELEVISION
BLACK & WHITE AND COLOR

ANALYST

By Easy Point-to-Point Signal Injection, You see the Trouble on the TV Screen and Correct it—Twice as Fast and Easy!

Simplified technique stops lost hours never recovered on "tough dogs", intermittents, and general TV troubleshooting. This one instrument, with its complete, accurate diagnosis, enables any serviceman to cut servicing time in half... service more TV sets in less time... satisfy more customers... and make more money.

With the Analyst, you inject your own TV signals at any time, at any point, while you watch the generated test pattern on the picture tube of the television set itself. This makes it quick and easy to isolate, pinpoint, and correct TV trouble in any stage throughout the video, audio, r.f., i.f., sync and sweep sections of black & white and color television sets—including intermittents. No external scope or waveform interpretation is needed. Checks any and all circuits—solves any performance problem. Gives you today's most valuable instrument in TV servicing—proved by thousands of professional servicemen everywhere.

Available on Budget Terms. As low as \$30.00 down.

Net, \$32995

SIMPLIFIES COLOR TV SERVICING, TOO

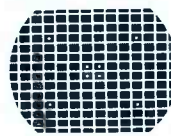

Enables you to troubleshoot and signal trace color circuits in color TV sets, or facilitate installation.



Generates white dot, crosshatch and color bar patterns on the TV screen for color TV convergence adjustments.



Generates full color rainbow display and color bar pattern to test color sync circuits, check range of hue control, align color demodulators. Demonstrates to customers correct color values.

Time-Saving, Money-Making Instruments Used by Professional Servicemen Everywhere



Model 960 Transistor
Radio Analyst



Model 360 V O Matic
Automatic VOM



Model 375 Dynamatic
Automatic VTVM



Model 700 Dyna-Quik
Tube Tester



Model 445 CRT
Rejuvenator Tester

See Your B&K Distributor
or Write for Catalog AP21-R



B & K MANUFACTURING CO.

Division of DYNASCAN CORPORATION

1801 W. BELLE PLAINE AVE. • CHICAGO 13, ILL.

Canada: Atlas Radio Corp., 50 Wingold, Toronto 19, Ont.

Export: Empire Exporters, 253 Broadway, New York 7, U.S.A.

Circle 25 on literature card

October, 1963/PF REPORTER 55

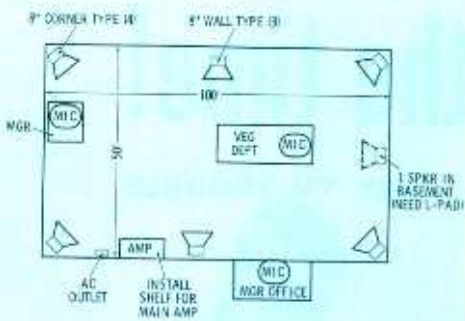

Fig. 1. Rough sketch of tentative equipment location is good groundwork.

uable asset for acquiring new PA business.

Getting Your Feet Wet

Once you have a list of likely prospects, you are ready to conduct a survey, to search out the information you'll need to make an estimate of each job. It's best to begin with a small notebook in which rough sketches can be made, approximate dimensions noted, and key locations marked. The more detailed this sketch, the more accurate the estimate will be, and the smoother the installation is apt to

run.

One typical layout sketch is shown in Fig. 1. Note that it shows the position of speakers, microphones, and the main amplifier. These points must be specified by the customer, but your expert help with acoustic problems can save later headaches.

In a typical supermarket, the store manager may wish to have microphones situated in three or more strategic locations: his "outer" office, usually near the cash registers; an "inner" office where he has a desk; and in the basement where stock is received and stored. Another microphone may be desired on the main floor, in the perishables department, to announce "specials." This is the kind of specific information your survey should uncover. (Most store managers are busy people, so check beforehand for an "off" hour when store traffic is low and you can get his undivided attention.)

Location of the amplifier is also determined by the customer. With space limited even in the largest stores, a shelf might have to be erected to make equipment acces-

sible, yet not an obstacle to normal business activity. Is there an AC outlet nearby? Is the equipment sufficiently out of reach to prevent tampering with the controls? When background music is to be fed through the PA amplifier, an automatic timer may be desired to turn on the AC power during business hours only. Explore every such possibility, and later complaints will be held to a minimum.

Other aspects of the survey concern the details which govern what tools and equipment will be required to properly complete the installation. A principal consideration is the physical layout of wires, and how many feet are needed. Check the walls carefully to see if wires can be attached to baseboards or moldings. If so, a heavy-duty stapling gun will be the fastest method for securing them. Special anchors will be needed for hard surfaces like masonry. Discover if there are any long runs that can be made behind decorative facings, within the walls, or above false ceilings.

Occasionally a special problem will exist, and it should be found during the survey. In one installa-

Trust your **24 HR SERVICE**
VHF or UHF—All Makes
TV TUNER REPAIR and ALIGNMENT to **JW**

Personal Service
EACH TUNER COMPLETELY SERVICED BY AN EXPERIENCED TECHNICIAN

VHF TUNERS	\$950	Prices are for service and unmutrated units. Missing, broken and damaged parts, defective tubes charged extra at LOW net \$17.95 prices. We ship C.O.D.
UHF TUNERS		
UHF CONVERTERS		
UHF-VHF COMBINATIONS		

OUR GUARANTEED SERVICE INCLUDES:

1. All tuners mechanically and electronically inspected
2. All necessary parts replaced
3. Contact surfaces correctly cleaned and lubricated
4. First test run for intermittents and drift indication
5. Fine tuning range checked on all channels
6. Local osc aligned to correct frequency all channels—XTAL controlled
7. RF alignment—all channels—XTAL controlled
8. AGC check, all channels—cut off of RF amp checked
9. Overall response all channels, shield covers in position
10. Quality control FINAL CHECK ALL UNITS, UHF-VHF

IMPORTANT:
Ship complete. Include all broken parts. State model and complaint. Package well to avoid transit damage.

JW ELECTRONICS Phone: EDison 2-0665
P.O. BOX 511 • BLOOMINGTON, INDIANA

Circle 26 on literature card

WANTED:

A man who wants to increase his income and build a business for himself.

HOW:

Pick up your phone and call a local architect, builder, or contractor and ask him this: "Are you interested in a new, inexpensive way* of providing TV-FM outlets in all rooms from a single antenna?" If the answer is "yes," fill out your name and address and mail this to:

CHARLES ENGINEERING, INC.

3421 North Knoll Drive
Los Angeles, California 90028

Name _____

Address _____

City _____ State _____

*U.S. Pat. No. 2,913,679—No special tools, techniques, or knowledge are required.

Circle 27 on literature card

Centralab

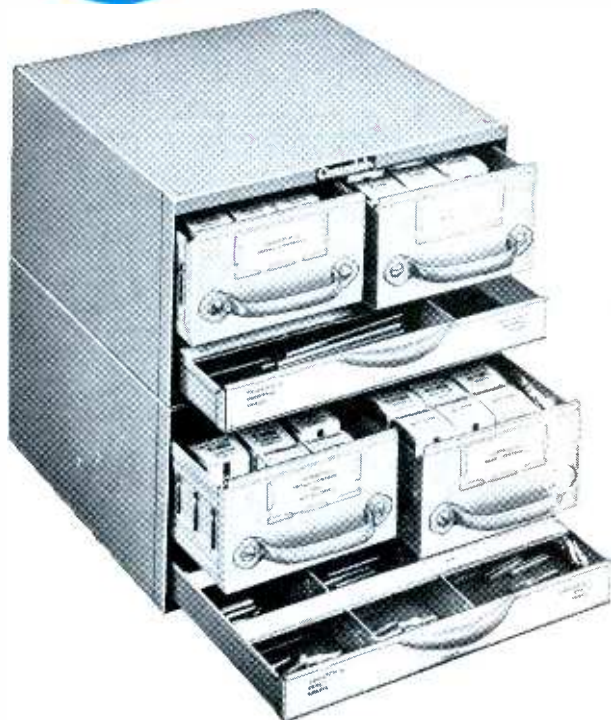

BRAND NEW CENTRALAB FASTATCH II® FRK-200 KIT WITH EXACT REPLACEMENT SHAFTS

Makes Control Replacement A SNAP!

- Centralab's new FRK-200 kit gives you the most convenient, most versatile, and simplest system for control replacement.
- Since it includes 13 sizes of exact replacement shafts, shaft cutting is eliminated on *all* the popular dual concentric controls and on almost 60% of all dual controls.
- The Fastatch II® Control System is a snap to use. Single and dual concentrics snap together without tools! Shafts plug in and are permanently locked. Assembled units can't loosen—shafts can't pull out.

JUST CHECK THESE EXCLUSIVE FEATURES:

1. Just one control system for dual concentric or single controls.
2. Universal terminals.
3. Plug-in, permanently locking shafts.
4. Rotary or push-pull (snap-on) line switches attach to both front and rear controls.

The FRK-200 kit is contained in two stacking Equipto steel cabinets with plenty of extra space for expansion. *All* your control needs, including push-pull, are at your finger tips.

THE FRK-200 KIT CONTAINS:

- | | |
|--|---|
| 35 Exact Front Shafts (7 sizes) | 9 Assorted Rear Controls |
| 30 Exact Rear Shafts (6 sizes) | 40 Assorted Universal Shafts for
Single and Dual Concentrics |
| 5 Universal Push-Pull Shafts
(1 size) | 5 SPST on/off Switches |
| 5 Push-Pull Line Switches | 2 DPST on/off Switches |
| 5 Twist-Tab Adapter Plates | 1 DP on/off Switch |
| 2 3-Drawer Equipto Cabinets | Complete with current
cross-reference guides. |
| 27 Assorted Front Controls | |

Dealer Net \$72.50

Less Credit for your old controls!



THE ELECTRONICS DIVISION OF GLOBE-UNION INC.
942 J East Keefe Avenue • Milwaukee 1, Wisconsin
TWX: 414-731-8731

In Canada: Centralab Canada Ltd., P. O. Box 400, Ajax, Ontario

B-6335

Circle 28 on literature card

October, 1963/PF REPORTER 57

tion, the most convenient wiring route was through a hole to be drilled between the main floor and basement. Close inspection revealed a subfloor of poured concrete about 18" thick. What might have proved to be a major obstacle was thus handled with ease: a powerful slow-speed drill and carbide bit were rented for the day of installation.

Once the requirements of a particular job are compiled, the estimate can be figured and the actual design worked out on paper. One critical aspect of the installation is speaker wiring. Unless such ele-

ments as wire size, length, and system impedance are carefully planned, much of the amplifier power could be dissipated before it reaches the speakers. Too often, a PA system is marred by a progressive drop in signal between the start and finish of the speaker bank—causing a speaker near the amplifier to blast, while a distant one on the same line is never loud enough. Fortunately, there are ways around this problem.

Getting the Job Done

Let's consider first a typical small

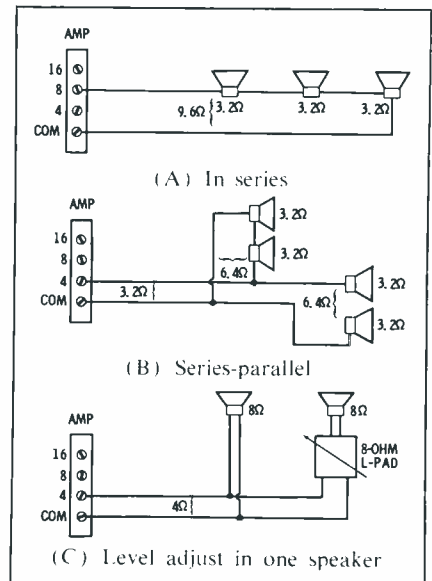

Fig. 2. Different methods of connecting short-run, multiple-speaker system.

installation where two or three speakers are required and wiring does not exceed more than about 50' in length. Such a system might be found in a beauty salon for handling background music or in a small industrial plant for summoning people to the telephone. A 15 or 20 watt amplifier will provide ample power, unless the noise level is high. The only problem is in matching the speakers to the amplifier output—generally rated at 4, 8, and 16 ohms.

Several possible wiring arrangements are shown in Fig. 2. Notice that speakers should be connected in series or series-parallel configurations so their combined impedance agrees as closely as possible with that of the amplifier output taps. In the systems of Figs. 2A and 2B, the level is controlled by the volume control on the amplifier; regardless of the setting, the available power distributes itself equally among all speakers. If the system requires balancing to compensate for unequal noise levels in various locations, an L-pad (Fig. 2C) can be used to preserve the impedance match of the system while permitting the sound output of a single speaker to be varied independently. However, an L-pad only allows power to be *reduced* in relation to the rest of the system.

Constant-Voltage Lines

Calculating series and parallel hookups becomes quite complex when more than a few speakers are used. These difficulties have been



- Tests TV and Radio Tubes—both old and new
- Tests all Novars
- Tests Nuvistors, 10-pin Tubes, and 12-pin Compactrons
- Tests Voltage Regulators, Thyratrons, Auto Radio Hybrid Tubes, European Hi-Fi Tubes, and Many Industrial Types

B&K PROFESSIONAL QUALITY AT LOW COST

Model 600 Compact Portable Dyna-Quik Makes Tube Testing Quick, Accurate, Profitable!

It's amazing how quickly you can accurately check out tubes on every call—sell more replacements, and make more money—with this up-to-date, low-cost professional quality tube tester.

Checks for all shorts, grid emission, leakage, and gas. Checks each section of multi-section tubes separately. Checks tube capability under simulated load conditions. Rejects bad tubes, not good tubes. Quickly reveals tube condition, saves customers, stops call backs, increases servicing profit.

Exclusive adjustable grid emission test. Sensitivity to over 100 megohms. Phosphor-bronze socket contacts.

Complete tube listing in handy reference index. Handsome, sturdy leatherette-covered carry-case.

Size 8½" x 11" x 4½" Net, \$74.95



QUICK, DIRECT, ERROR-FREE
READINGS WITHOUT MULTIPLYING

Model 375
VTVM
Net, \$89.95



Model 360
V O Matic
Net, \$59.95

See Your B&K
Distributor
or Write for
Catalog
AP21-R



B & K MANUFACTURING CO.

Division of DYNASCAN CORPORATION.

1801 W. BELLE PLAINE • CHICAGO 13, ILL.
Canada: Atlas Radio Corp., 50 Wingold, Toronto 19, Ont.
Export: Empire Exporters, 253 Broadway, New York 7, U.S.A.

Circle 29 on literature card

THE SAME ENGINEERING, SAME PLANT THAT
PRODUCES AMERICA'S GREATEST SATELLITE-
TRACKING AND TELEMETRY STATIONS, HAS CREATED

the revolutionary new

PARALOG

TV/FM ANTENNA

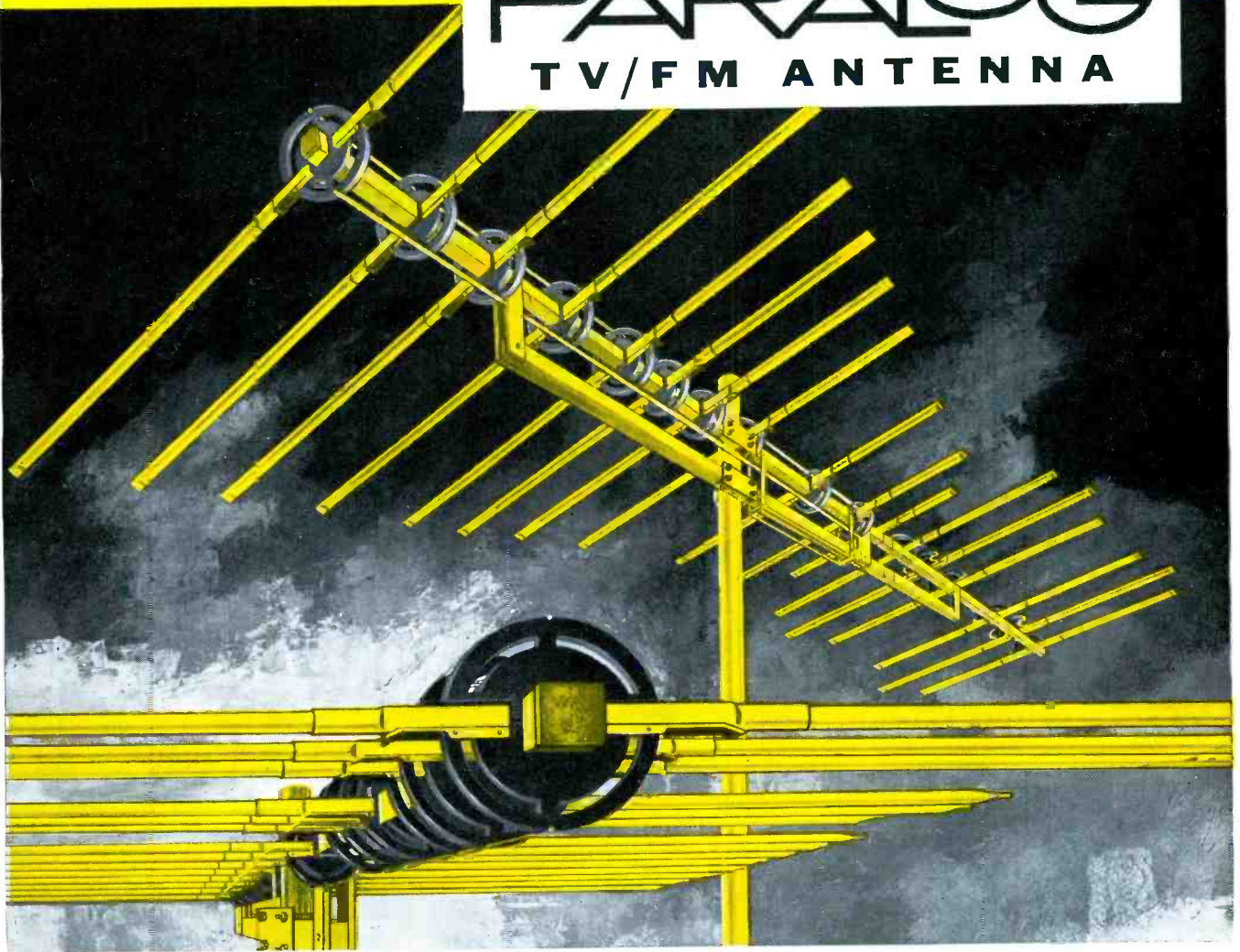

... Unparalleled performance because it has **ALL 5:**

- HIGHEST GAIN
- SHARPEST DIRECTIVITY
- EXTREMELY LOW VSWR
- BEST FRONT-TO-BACK RATIO
- RUGGED CONSTRUCTION

HERE IT IS—the space-age TV/FM antenna from the only manufacturer with actual experience in making space-probing antennas!

All new, the PARALOG is the first home antenna that really comes through with log-periodic

design plus a unique parasitic-element system for maximum all-channel gain and pinpoint directivity. Exclusive Cyclocac insulating mounts assure constant impedance, eliminate troublesome cross-feed design. Extremely rugged construction.

JERROLD
TACO

There are fourteen PARALOG antenna models, listing from \$19.95, including four electronic PARALOGs with Super Powermate preamplifier, and three special FM stereo models. See your Jerrold-TACO distributor now, or write Jerrold Electronics, Philadelphia 32, Pa.

Circle 30 on literature card

TRANSISTORIZED CHARGER

MADE IN U.S.A.

FOR WINTER-WEAK BATTERIES



- TO AC WALL OUTLET
- TO CIGAR LIGHTER

• MODEL NO. BC-6 FOR 6 VOLT
 • MODEL NO. BC-12 FOR 12 VOLT
ONLY \$280 DLR. NET

AT YOUR ELECTRONIC DISTRIBUTOR



Circle 32 on literature card

CORRECT OFF-STANDARD VOLTAGE WITH



Acme Electric

VOLTAGE ADJUSTORS

You can't get the best performance from a TV set or other electronic equipment unless it's operating on proper voltage. The Acme Electric T-8394M Voltage Adjustor corrects voltage over a range of 95 to 125 volts to normal 115/120 volts, simply by turning a regulating switch. Have a T-8394M Voltage Adjustor with you on every service call. You can use it for testing the line—and sell it on more jobs than you realize. A full 300 watts. Compact. Inexpensive. Most good supply dealers stock them. For full information write for Bulletin 161. SAA 3673-3027

ACME ELECTRIC CORPORATION

9410 WATER ST. • CUBA, N. Y.

In Canada Acme Electric Corp. Ltd., 50 Northline Rd., Toronto, Ont.

Circle 31 on literature card

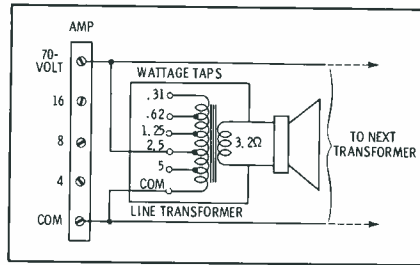

Fig. 3. Full capacity of amplifier can be utilized with special transformer.

largely eliminated by the widespread use of a device called the *constant-voltage* line.

In operation, this line is similar to the distribution system used for common house current. You can plug any combination of devices into 117-volt AC without regard to their impedance or power consumption—as long as the total capacity of the power line is not exceeded. The constant-voltage system for PA works the same way. You may add speakers of any type, in all conceivable combinations, up to the full power capacity of the amplifier.

Most modern PA amplifiers produced today make provision for constant-voltage applications. The output terminal strip contains, in addition to the usual voice-coil taps, a terminal designated *70 volts* (nominally 70.7 volts rms). Circuitry is designed so the amplifier delivers a constant voltage into the speaker line at all times.

To wire any speaker across the line, it must be fitted with a line transformer of the 70-volt type, as shown in Fig. 3. Various wattages are marked on the transformer taps to give the installer a choice of power level fed to a speaker. This feature is of great assistance during final balancing of the system. A horn used to cover a parking lot, for example, might use a 5-watt tap, while a small paging speaker for indoors may need only 1.25 watts for adequate coverage.

Introducing level control to in-

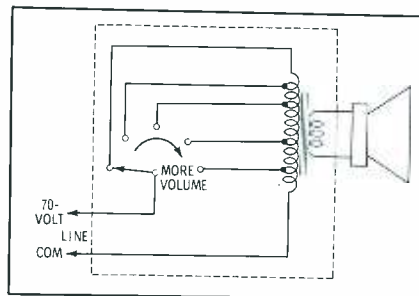

Fig. 4. Tap-switching line transformer selects level for speaker line.

dividual speakers or groups is greatly simplified by the constant-voltage system. Fig. 4 shows a specialized line transformer which contains a tap-changing switch. Each time the switch is advanced, an additional 3 db (double the power) is fed to the speaker. This results in a small but quite audible increase in the sound level.

It is also possible to insert an L-pad directly at the voice coil of the speaker, as in Fig. 5A. Unlike the tap-changing transformer, the L-pad wastes power, but it is inexpensive. If the application does not require continuous control of level, a simple toggle switch can be installed in the line or voice coil (see Fig. 5B). Be sure every component is rated to handle the maximum power the speaker will require.

Occasionally, you will encounter components intended for use in a constant-voltage system, but marked in ohms rather than watts—on a line transformer, for example. Converting ohms to watts in a constant-voltage system is done with a simple calculation. Just divide the impedance marked on the transformer into 5000; the result is the number of watts drawn by the winding.

Conclusion

It is apparent that one of the chief concerns in planning a PA system is that of handling audio power between amplifier output and speaker inputs. Much design information has been carefully calculated and is readily available from leading manufacturers of PA equipment. Charts tell you everything from how much power loss you can expect from a given wire size to how frequency response is affected by speaker line impedance. These charts should become part of your library if you contemplate the expanding field of PA sound. ▲

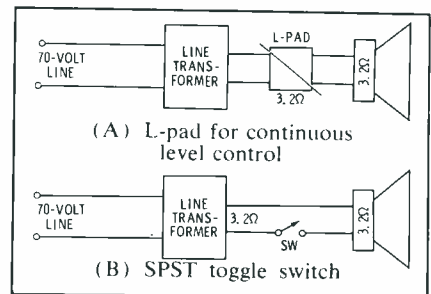

Fig. 5. Two methods to permit control of level at a particular speaker.



...leave sooner—get there faster!



It's there in hours...and costs you less!

	Buses Daily	Running Time	15 Lbs.	25 Lbs.	35 Lbs.*
BOSTON— NEW YORK	18	5 hrs. — min.	\$1.80	\$2.10	\$2.35
PITTSBURGH— CLEVELAND	14	2 hrs. 55 min.	1.60	1.85	2.15
CHICAGO— ST. LOUIS	8	6 hrs. 10 min.	1.90	2.15	2.45
LOS ANGELES— SAN DIEGO	38	2 hrs. 30 min.	1.25	1.45	1.70
CINCINNATI— LOUISVILLE	15	2 hrs. 40 min.	1.50	1.70	1.95

* Other low rates up to 100 lbs.

Save time! Save money! Ease those inventory control problems too! Ship via Greyhound Package Express! Packages go everywhere Greyhound goes, on regular Greyhound buses. Very often they arrive the same day shipped. Ship nationwide, anytime... twenty-four hours a day, seven days a week, weekends and holidays. Ship C.O.D., Collect, Prepaid, or open a charge account. Insist on Greyhound Package Express. **It's there in hours... and costs you less.**

Circle 33 on literature card

GREYHOUND PACKAGE EXPRESS, Dept. 52-W
140 S. Dearborn St., Chicago 3, Illinois

Please send, without cost or obligation, complete information on Greyhound Package Express service including rates and routes.

NAME _____ TITLE _____

COMPANY _____

ADDRESS _____

CITY _____ STATE _____ PHONE _____

**CALL YOUR LOCAL GREYHOUND BUS TERMINAL
 OR MAIL THIS CONVENIENT COUPON TODAY**

Cheerful Charlie's TRIBULATIONS



How does a guy with a one-man shop ever get any work done? —by Charles F. Lieder

I had the shop work caught up —almost. I had just finished a good supper and was settling down for an evening of reading when my wife asked casually when our local TV station was going to start broadcasting again.

Surprised, I exclaimed, "Honey, they've never quit!"

"Well, I wouldn't know," she replied, "Our set hasn't worked for so long that I was just wondering. . . ."

Only a gentle hint, I knew, but I answered, "You probably forgot to plug it in or to reconnect the antenna lead after the last storm."

But she persisted, "It would work just about as well unplugged as it does when I turn it on. Why don't you try it? Maybe we can watch it awhile and you can see for yourself."

I realized I hadn't much choice, so I turned the set on and we sat down to watch it. The set worked well; the picture was clear, and the sound was fine. But I understand TV sets almost as well as I do my wife (and that's not necessarily bragging), so I knew something would soon happen.

After about ten minutes there was a slight horizontal quiver and a quick flash of horizontal lines. Then, all was okay again.

My wife tried unsuccessfully to conceal a slight smirk. Just then, the phone rang, and she went to answer it. When she said "Oh, hello, Clara!" I knew she'd be oc-

cupied for a while. Here was my chance.

The picture on the TV presently broke into rough horizontal lines, with occasional tell-tale squегging that meant wild horizontal oscillation. Then it settled back again, but I was sure it would go completely wild as it got warmer. Being a little on the tricky side, I said to myself, "I'll show her up," and felt in my pocket for the little tuning stick that is my constant companion.

My set uses a *Synchroguide* horizontal system, with a double coil in the horizontal oscillator. When the circuit develops these wild tantrums, the .01 capacitor across the waveform coil is generally the culprit. Replacing this capacitor and retuning the coils usually cures it.

There is also a temporary cure, which consists of simply readjusting the waveform coil when the receiver is well warmed up. This is the method I used to trick my poor wife.

While she continued talking on the phone, I sneaked her hand mirror from the dresser. Then, reaching up from underneath the set (through a hole I'd made in the screen), I turned the coil core till the picture was stabilized. I snapped the station selector off station a couple of times to make sure the oscillator would hold. My luck was good, so I put the mirror back and settled down—with crossed fingers—to enjoy the program.

My wife came back into the room, looked at the TV, and seemed a little surprised, but she said nothing. We watched it the rest of the evening with no further trouble. Later on, one very smug serviceman said to one somewhat puzzled wife, "You must have imagined the TV wouldn't work—or just don't know how to operate it. . . ."

Who's Smart?

I had slipped out of that quite well, and felt pretty pleased with myself. However, my ego never gets very high before it's flattened again, and this time was to be no exception—as I found out the very next morning.

One of my customers, an elderly man, came in early and perplexedly asked if our local station was broadcasting programs from a foreign country. I didn't understand what he was getting at. I hadn't heard of any foreign broadcast, and said so.

"Well," he said, "The pictures look good and the people speak English, but I can't read any of the words that are shown with the commercials. They all look funny ever since you put in that new yoke last week."

With a sinking feeling in the pit of my stomach, I realized what had happened. I had goofed—again! I remembered the job, and recalled having played the set for some time after installing the yoke. But I'd slipped up by not observing the set closely enough or comparing

*makes other
tube testers*

OBSOLETE

HICKOK

Model 800A

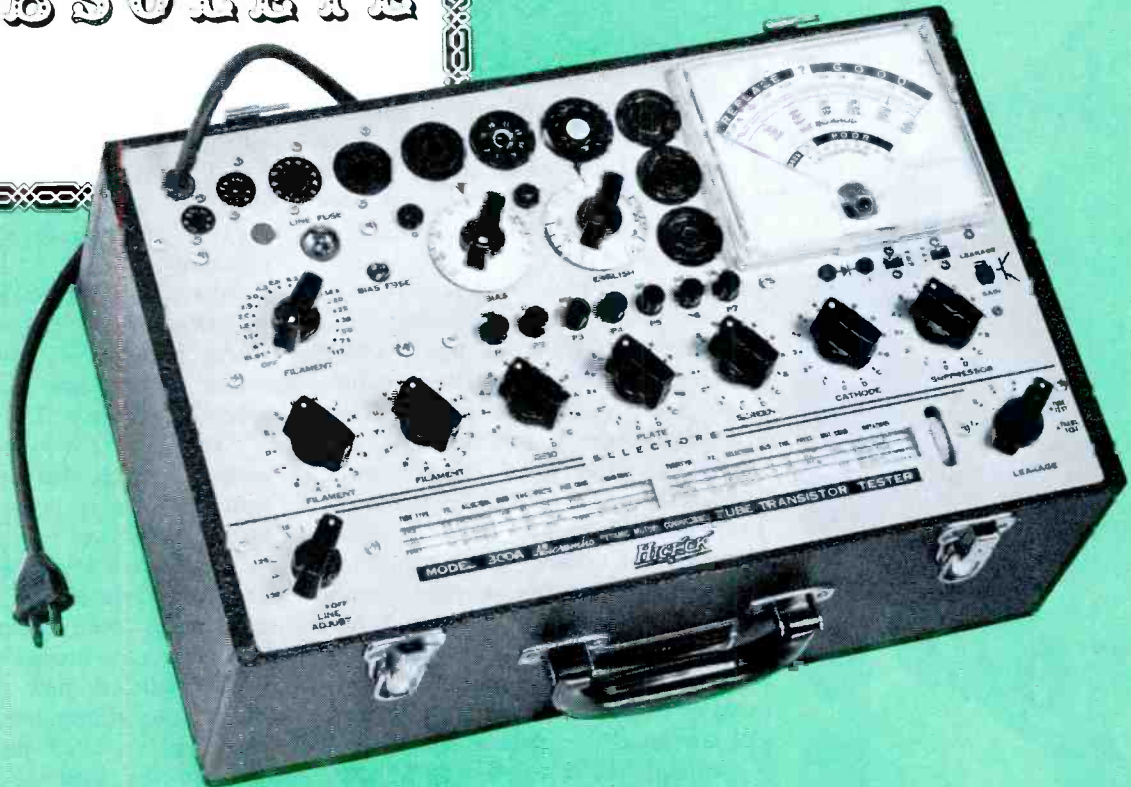

Honest tests on today's tubes demand 14-position selector switches. Compactrons, novars, 5- and 7-pin novistors, 10-pin headers, transistors and diodes, along with the older type tubes, can all be checked out—completely and correctly—including high sensitivity leakage and gas tests, with the truly modern Hickok Model 800A. This quality tube tester includes these other recognized Hickok-quality features: Hickok-developed G_m test on all tubes • Sensitive, instantaneous inter-element leakage and shorts test • Filament continuity test—and the original HICKOK roll chart subscription service keeps it up-to-date!

*Best of all, Hickok's low price for this portable do-it-all tester is only **\$199.95**. Available from stock at your franchised Hickok distributor. Let him give you a demonstration.*

**Ask to see
these other
Hickok
instruments, too**



677
Wide Band Oscilloscope



470A
Uni-scale VTVM

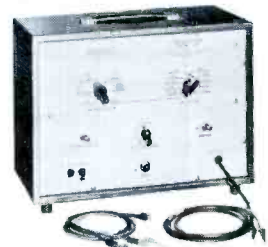

661
Color Bar Generator

THE HICKOK ELECTRICAL INSTRUMENT CO. • 10566 Dupont Avenue • Cleveland, Ohio 44108

Circle 34 on literature card

NEW

LEAN 'N MITY



EDP SHOW
Room 641A
(Sound Section)

MODEL 8HAB

ALNISPHERE ALNICO V

Soon to be the industry's most imitated speaker . . . a new heavy magnet, slim profile sound speaker designed and built to give unexcelled performance through the use of ALNICO V, the industry's most efficient speaker magnet material . . . from Oaktron.



AKTRON
INDUSTRIES, INC.
MONROE, WIS.

Circle 35 on literature card

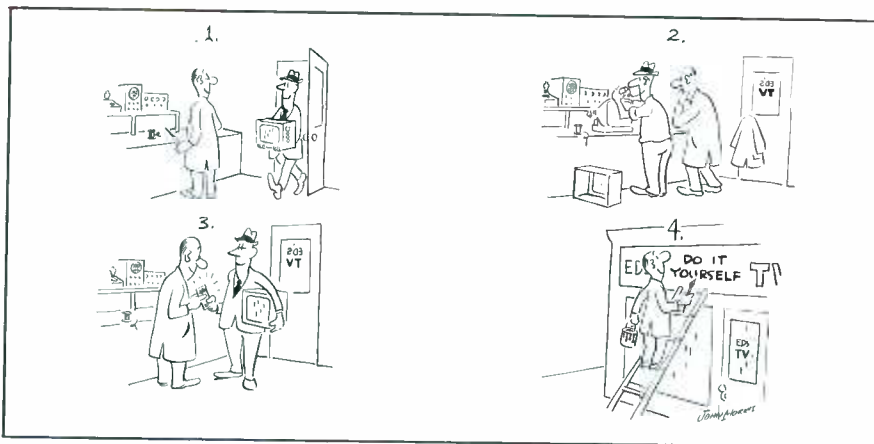

it with another. As you've guessed, I had wired the horizontal yoke winding backwards, and a picture which is reversed this way can look quite normal unless there is printing on it.

I seldom make mistakes (except when I'm doing something), but I don't try to cover up. I admit them, and I think this gives customers more confidence in me. They know that no one is infallible, and they seem to place reliance on a person honest enough to admit his errors and rectify them (without charge, of course). This customer, not too surprisingly, seemed pleased to learn it was a mistake I had made; he evidently liked that idea better than the thought that something else was wrong with his set. I corrected the trouble, apologized, and still had a satisfied customer.

Symptoms of Progress

But, oh—this modern age! Even TV trouble symptoms appear to have changed, especially the way people describe them. The other day, I had barely gotten through the door of one customer's home when the lady of the house started

describing how the TV had been acting.

"The picture flickered and jumped, just like spaceships and rockets shooting through it!" she exclaimed.

Spaceships? Rockets? I was a bit stunned. I began wondering where I might get some quick information on how to remove a spaceship from a TV set.

"That's what it looked like," she assured me. "It also made snapping sounds; then it popped, and the picture went out."

I collected my wits somewhat, and then decided the high voltage must have been arcing until the fuse blew out. Investigation proved I was right. A new damper tube and a fuse eliminated the "spaceships and rockets," putting the set back in the business of showing ordinary pictures.

Who Gets the "Shakes"?

I was glad this had been a simple job, for my thoughts of a set that was waiting on the bench were giving me the jitters (with good reason — because jitter is what the set had).

MERCURY TUNER SERVICE, INC.

890-1 River Ave., Bronx 51, N.Y.

"Largest in the East"



VHF-UHF TUNERS

One Year Warranty

Price Includes Labor & Minor Parts

TUBES & MAJOR PARTS
AT NET PRICES

When Shipping Tuner: Include Tubes,
Shields and Damaged Parts.
Give Model Number and State Complaint

PACK WELL AND INSURE
24 HOURS ON POPULAR TYPES

ALL MAKES
ONE PRICE!

\$9.50

Circle 50 on literature card

NEW
ELECTRO-VOICE
MODEL
676
CARDIOID
MICROPHONE

Outperforms them all...or your money back!

 In the last 36 years, Electro-Voice engineers have developed many important microphone firsts*, but their latest achievement, the new E-V Model 676, may well be their most significant contribution.

The goal of 676 design was to overcome some of the most basic problems in PA, hi-fi recording, and communications. The result of this engineering effort is a uniquely versatile dynamic cardioid microphone with the best field performance of any we have tested. In short, the 676 does *everything* a little better.

For instance, response is wide, uniform, and smooth in the E-V tradition of natural sound. But the 676 also allows you to *change* response. Now you can "neutralize" room reverberation and rumble (usually encountered in larger rooms). A built-in three-position switch allows selection of flat response (for small rooms or recording), or bass attenuation "tilted off" from about 800 cps, with response down either 5 db or 10 db at 100 cps.

This means you get higher average sound levels, better intelligibility, and less likelihood of feedback. Yet there is no "missing bass" effect, common with most tone controls or

filters, because of the flat-slope characteristic of the 676 bass tilt-off.

The cardioid pattern and response superiority of the 676 results from a creative variation of the famed E-V Variable-D® principle, called Continuously Variable-D (CV-D). It reduces size and weight without compromising quality, and it's responsible for reducing wind noise and shock noise pickup far below that of any other small cardioid. Bass-boosting "proximity effect" is gone, too, to give you well-balanced sound, even when performers work ultra-close.

Basis of the CV-D^T design is a slotted tube, coupled to the back of the 676 diaphragm. The CV-D tube appears to vary in length—acoustically (and automatically)—so that low tones "see" a long tube, while high tones "see" a short tube. The apparent length of the tube is always just right to phase out sound arriving at the back—for maximum front-to-back cancellation.

Modern styling by noted designer Lute Wassman adds grace and beauty to 676 practicality. The one-inch case fits all present E-V slip-on stand mounts, and its balanced weight

distribution is just right for hand-held use.

But there's more to the 676 than just new features—built into it are the many characteristics that make E-V the choice of more professional sound engineers than any other brand: high output level, exclusive E-V Acoustalloy® diaphragm, dual impedance selection, efficient dust and magnetic filters, and the most important ingredients of all—fine materials and quality workmanship.

Accept our invitation to try the 676 soon—and the more difficult the job, the better. We guarantee you'll find the 676 will outperform any other PA cardioid microphone you are now using...or your money back!

Model 676—\$100.00 list (less normal trade discounts). Complete specifications available at your E-V sound specialist's or write to: ELECTRO-VOICE, INC., Dept. 1032R, Buchanan, Michigan.

*Some of the E-V microphone firsts include: The Differential, Mechanophase, Variable-D®, Cardiline and Sound Spot®, plus slim dynamic and lavalier microphone designs, Acoustalloy® and Acoustifoam. And the E-V Model 642 has earned the first Academy Award microphone citation in 22 years, for its contribution to motion picture sound.

Circle 36 on literature card

Electro-Voice®
SETTING NEW STANDARDS IN SOUND

new Allen hex screwdrivers

work faster, easier . . . reach where wrenches won't go



fixed handle SCREWDRIVERS

11 hex sizes
.050" to 1/4"
Precision formed, alloy steel blades
Shockproof, breakproof, amber plastic (UL) handles

detachable BLADES

8 hex sizes
1/16" to 3/16"
Fit all "99" Series handles
Available singly — as a set of six in free plastic pouch — or in roll kit with handle

WRITE FOR BULLETIN N763

XCELITE

XCELITE, INC., 18 BANK ST., ORCHARD PARK, N. Y.
Canada: Charles W. Pointon, Ltd., Toronto, Ont.
Circle 37 on literature card

66 PF REPORTER/October, 1963

It was neither horizontal nor vertical jitter; every line around every object in the picture appeared zigzag. People looked like grotesque dolls cut from paper with pinking shears. Also, everything did the most peculiar shimmy—up, down, and every which way.

When the customer had brought in the set (a portable), he made the usual remark, "I guess a tube is bad." Not even dignifying his inane remark with an answer, I attached an antenna clip, plugged the set in, and turned it on.

One good look at the picture caused me to say fervently, "I really wish it was!" That one look had told me I was going to have trouble, for I had never seen anything like this before.

I took the back off and tried it again, using my eyes, ears, and nose to detect some trouble. I could see no evil, hear no evil, and smell no evil.

Testing the tubes in the horizontal and high-voltage circuits didn't reveal any trouble, although it did make my customer feel I was doing something more than just standing there wondering what to do next.

Sometimes, when I'm caught with a problem set and don't quite know what to do (the owner is expecting me to find the trouble in a jiffy and I can't), I borrow a trick from my doctor: I probe and push on tubes and wires, at the same time muttering, "Hmm" and "Ah." Then I come up with something like, "There seems to be a fracture of molecular structure in one of the current carriers, causing it to become a nonconductor. A disruption such as this can be difficult to locate, since the severed member

is frequently encased in an adhering substance which may form an insulating barrier between it and. . ."

By now, the customer (most of mine know me pretty well) surmises that I don't know what the trouble is and will have to look for it. So he's willing to leave the set—and me — for further contemplation. This time, I frankly told the man it appeared to be a rough one. He left the set, with his best wishes, hoping I could fix it soon.

I had other work which had to be done first, and a few service calls to make, so I had to leave that set for a bit—and was rather glad of it. Yet, through the rest of the day that shaky picture haunted me.

That night, while TV audiences were enjoying the evening shows, I was watching, but not enjoying, them. I had tuned in the wiggly picture and let the receiver run while I did some other work.

Even after playing quite a while, the set showed no other signs of trouble. The sound was okay, the picture bright, the contrast good, and the raster well filled out. It just had that terrible jitter.

Adjusting the controls didn't do a thing for it. High-voltage corona was the only cause I could think of for this crazy effect. Next, I pulled the chassis. As this was a vertical chassis, the picture tube was mounted separately, so I used my little test CRT to make a bench setup.

When everything was ready, I fired up the chassis—and was I surprised! It showed a very pretty picture — clear, no shimmy, with everything normal. I immediately used my tester on the old picture tube, but it tested very good.

PRECISION TUNER SERVICE

P. O. BOX 272

1200 S. WALNUT ST.

BLOOMINGTON, IND.

EDISON 99653

7.50
V or U

COMBO PLUS
9.95 POSTAGE

6 MONTH WARRANTY



All Types T.V. Tuners Cleaned, Repaired and Aligned to Factory Specifications. Same day in shop service on most Tuners. Price Includes Minor Parts, Major Parts at Cost Price. We use Original Parts if possible. State Make Model and Enclose all Parts and Tubes. Pack Well and Insure.

ALSO HAVE LARGE STOCK OF EXCHANGE TUNERS, WRITE FOR TYPES AND PRICES.

Circle 38 on literature card



There's more profit in your hands with ITT tubes

Yes, you can pocket extra profit when you stock ITT receiving tubes . . . with full confidence that you are giving your customers the finest replacement tubes money can buy.

Your customers will appreciate it, too, because they know ITT's international

reputation for quality and leadership in electronics.

ITT can provide this "extra value" of finest quality at higher profit margins because ITT products are available from 154 factories and laboratories in 24 countries. Brands without these world-

wide resources cannot offer you these advantages.

Ask your local distributor about ITT tubes. He'll give you *extra profit* details.

ITT Distributor Products Division, International Telephone and Telegraph Corporation, Box 99, Lodi, New Jersey.

Circle 39 on literature card

ITT

**Save your
Meter Movement
Make it
Burnout Proof!**



Installed in minutes . . . on most any meter . . . such as the Simpson 260 or Triplett 630, etc. Positively prevents meter movement burnout or damage . . . even if subjected to as much as 100 times overload. Accuracy not affected by more than 1/4 of 1%. Not a fuse. No moving parts . . . nothing to wear out. End the time loss, expense and aggravation of meter movement repair due to burnout.

SATISFACTION GUARANTEED OR
YOUR MONEY BACK. ONLY \$2.95

See your distributor today; if he does not stock Metergard, send check or M.O. direct to



LECTROTECH INC.
P. O. Box 531, Skokie, Illinois

Circle 40 on literature card

New BERN'S Perfect Pin Crimper

Picture-Tube Repair Tool

Also for—5U4, 6SN7, 6BQ6, etc.

Eliminates that hard
soldering job

only \$1.25
each

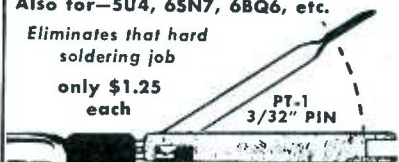

Fix loose pin connections in seconds. Pays for itself in time saved on first job. 3" long.

Patented

Intermittent operation of picture tubes due to defective solder connections easily corrected. Provides solid electrical connections, can also be used as channel-selector wrench and screwdriver. Pin keeps its original form. A 3-in-1 tool.

3 MODELS

ELIMINATE SOLDERING

Makes Solid Electrical Connections
Phono Pin-Plug Crimper

Slip wire in "pin plug," insert in tool, and squeeze job is done.



C-rings 1c ea.

Use end of tool to push on C-ring for ground connection.

Ant. plugs, hi-fi, multiple plugs, public address, radio and TV tubes, radar, speakers, and loop connections. Many, many more uses.

Model LC-3 for 5/32" pin diameter

At your parts distributor or write us



Mfg. Co.
9853 Chalmers,
Detroit 13, Mich.

Circle 41 on literature card

Well, can't win every time, I thought—although I was beginning to wish this job had gone to one of my competitors.

Using CRT extension cables, I connected the chassis and the picture tube together again, leaving the chassis out in the open. When I turned it on, there was the surrealistic picture again.

I tapped the neck of the CRT, but there was no sign of arcing in the gun. Standing a mirror in front of the set, I watched the picture while I tapped, but saw no change at all.

By this time it was getting late. Tapping hadn't done any good; perhaps if . . . I started to reach for the hammer, but did a wiser thing instead: I quit and went home.

The night didn't pass too well for me. But the next morning, after getting on the outside of some eggs, coffee, and toast, I felt as if I could once more face the puzzle on my workbench.

The first thing I did when I came into the shop was give the set a dirty look. It helped (me, anyhow). I turned the thing on, sat down, and just looked — and thought. Possibly it had a faulty ground connection to the outer coating of the CRT. Or perhaps there might be some dirt, grease, crayon, lipstick, glue, or who-knows-what in the second-anode button.

When I inspected that point, I saw the light — too much light. There was a bright clear ring inside the glass bulb all around the anode terminal where the inner coating had flaked away. This had caused arcing inside the picture tube, creating the bizarre effect. A new CRT cured the trouble. What hurt was: My customer had been right; it was only a bad tube.

Friends and Flybacks

My friend Bud came in, with his usual hustle and clamor. "I brought my TV along. Have you got a place for it?" he asked.

I pointed toward a trash barrel, but Bud ignored the hint. I helped him bring the set in and place it on a work table.

"What's wrong with it?" he asked immediately.

"Oh," I answered, "the picture tube is shot, the yoke is shorted, and a couple of small tubes are burned out."

"How can you tell without even checking it?" he snorted.

"If you didn't think I could, why did you ask me?" I countered.

"All right! All right!" he replied. "Guess I deserved a silly answer. Now, suppose you go ahead and start poking around, stumble across the trouble, and fix it. Then you can charge me some outrageous amount, and I'll go home and watch TV because I won't have enough money left to do anything else."

While Bud was making this speech, I prepared the set for testing and fired it up. The sound came in fine but there was no raster. Using a little neon bulb taped to a dowel stick, I checked for RF at the plate cap of the horizontal output tube. None was present.

Testing the horizontal and damper tubes didn't turn up any trouble, but checking the flyback did; my ohmmeter showed the primary coil to be open.

Bud was happy when I told him the tubes were okay and the trouble was just a bad connection. But when I told him where it was, and how much the repair would cost, I thought I'd lost a friend.

"There goes my mad money for the next three months," he moaned.

Installing a new transformer in Bud's set put it back in operation, but the screen showed only horizontal lines. Adjusting the horizontal hold produced a lovely picture, with the horizontal blanking bar right in the center of it.

Adjusting the stabilizer and waveform coils didn't help at all. The picture would stabilize only with the bar in the middle. I checked my wiring with the schematic, and reread the information supplied with the new transformer; everything appeared to be as it should be.

I explored the horizontal AFC phase-detector stage with the scope. The waveforms seemed all right, so I went through the oscillator stage to the grid of the output tube. The waveforms all looked okay.

I turned my attention back to the phase detector. This time, a more careful look at the pulse from



Tips for Technicians

Mallory Distributor Products Company
P.O. Box 1558, Indianapolis 6, Indiana
a division of P. R. Mallory & Co. Inc.

About voltage ratings on electrolytics

Maybe this has happened to you. You've got to replace a 10 mfd electrolytic capacitor. On its label, loud and clear, you read 200 volts. You look on your shelf. No 200 volt units in sight—but there's one that says 10 mfd 300 volts. Question—can you use it, and if so, will it reform itself and become a 200 volt capacitor when used at the lower voltage?

Answer—you can, and it won't.

The reforming of electrolytics to lower voltage is an idea held over from the ancient days of wet electrolytics, which had a tendency to adjust themselves to the voltage at which they were being used. This doesn't happen with modern electrolytics, especially the way Mallory makes them.

You can rely completely on the voltage rating you read on a Mallory capacitor's label. We've built in the safety factors *before* we print the voltage rating on each capacitor. This means you can use a Mallory capacitor right up to its rated DC working voltage, at rated ambient (this is 85° C. for FP's, WP's and TC's) without worrying about premature failure or call backs. And you have inherent extra muscle to withstand the usual surge voltage above rated value. Conversely, you can *always* use a Mallory capacitor *below* its rated voltage when convenience demands it; you're just buying some extra reliability at a bargain price.

When necessary, you can use Mallory electrolytics at temperatures beyond 85° C. You won't get as long life, and you'll need to run them below rated voltage. No hotter than 105° C., please, and no higher than 400 volts. The chart at left gives you typical temperature derating data. If you run into higher temperatures, you really need one of our fine tantalum capacitors.

The best way to make sure you get the electrolytics you need is to see your Mallory distributor. He carries a complete line of all ratings of Mallory FP, WP, TC, TT and wax tubulars. Right now, he is featuring a new dealer cabinet that gives you a compact, convenient working stock of most popular FP types. See him soon—make him your headquarters for all your parts requirements.

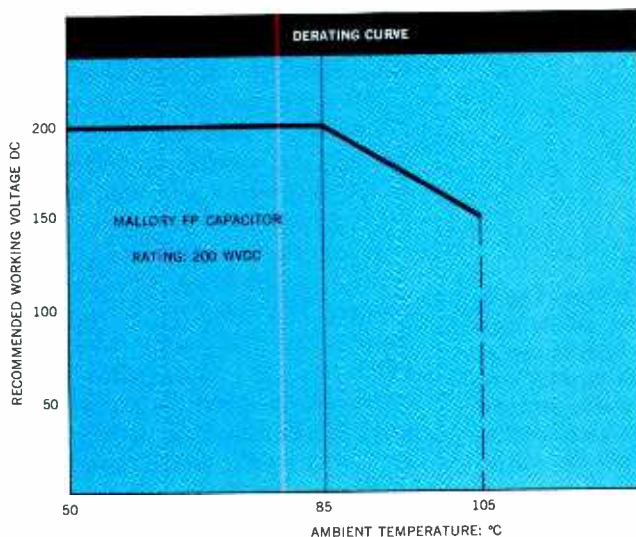

Circle 42 on literature card

TELEVISION F. M. RADIO

CROSSWAY TELEVISION - RADIO
SALES - SERVICE

ANBURY ROAD ILTON, CONN.

Customer's Order No. _____ Date _____ 196__

M. Cash

Address _____

SOLD BY CASH C. O. D. CHARGE ON ACCT. MISC. PAID OUT
RET.

QUAN.	DESCRIPTION	PRICE	AMOUNT
2	5U4GB		4.20
1	6CD66A		5.75
1	6AF4A		4.-
	Label		5.-

Rec'd by _____ Tax _____

No. 002062 ALL claims and returned goods MUST be accompanied by this bill. 49
1944

Now, put more profit in this

with this!



NEW SONOTONE VALUE LINE

How much of that figure called "total" is profit? Depends on the cost of the tubes. That's why the new Sonotone Value Line puts more profit into that bill: they cost much less! They're top quality, first-line tubes, too. Every one is thoroughly tested to meet Sonotone's rigid quality standards—no more extra callbacks. And Sonotone makes sure you can enjoy these

extra profits on all calls. The Value Line includes all the popular home entertainment types—the ones you're most likely to need. So ask your distributor for the Sonotone Value Line. Start making bigger profits tomorrow. Now your distributor has two great Sonotone lines—the new Value Line and the well-regarded Premium Line.

SONOTONE CORPORATION • ELECTRONIC APPLICATIONS DIVISION • ELMSFORD, N. Y.
Cartridges • Speakers • Tape Heads • Microphones • Electron Tubes • Batteries • Hearing Aids • Headphones

Circle 43 on literature card

the flyback revealed that the saw-tooth pulse was slanted opposite to what it should be. The leads from the take-off winding had to be reversed.

Bud was back later to pick up the set, still grumbling about the high cost of TV. A cup of coffee (for which I paid) helped smooth his jangled nerves, and he hustled off home to watch TV and brood.

The Suburban Trade . . .

While I was concentrating on fixing a small radio, the shop door was flung open without ceremony. Two men came in carrying a table-model TV, with—I'm not kidding!—oats dripping from it in several places. They sat it up on the counter.

I noticed it was about half full of grain and remarked, "These things run on electricity. You don't have to feed them!"

One farmer chuckled and said, "I thought it'd ride easier on the load of oats I'm hauling. I guess it kind of sank into 'em. But you can keep the oats for cleaning 'em out. They ain't worth much now, anyhow." (This wasn't the first time I had been offered chicken feed for my services.)

"My set works good, but it looks funny," he continued. "You see bright lines across the top of things, and under printed words and stuff like that. Then sometimes it looks pretty good again. I'll leave it for a few days, since we don't have much time to watch it this time of year, anyhow."

From his description, I suspected I might be running into an oddball type of trouble again. This always makes me as happy as finding a ten-dollar bill—one I haven't paid.

After completing the radio job I'd started, I returned to the farmer's set and started shoveling oats. A TV technician sure has to have a lot of talents.

When the set was finally accessible, I turned it on, to observe its action. The picture lit up very slowly, but the raster completely filled the CRT face when it did come on—a good indication of a weak CRT. However, it brightened up fairly well after considerable operation. The picture looked reasonably good, although it did lack contrast.

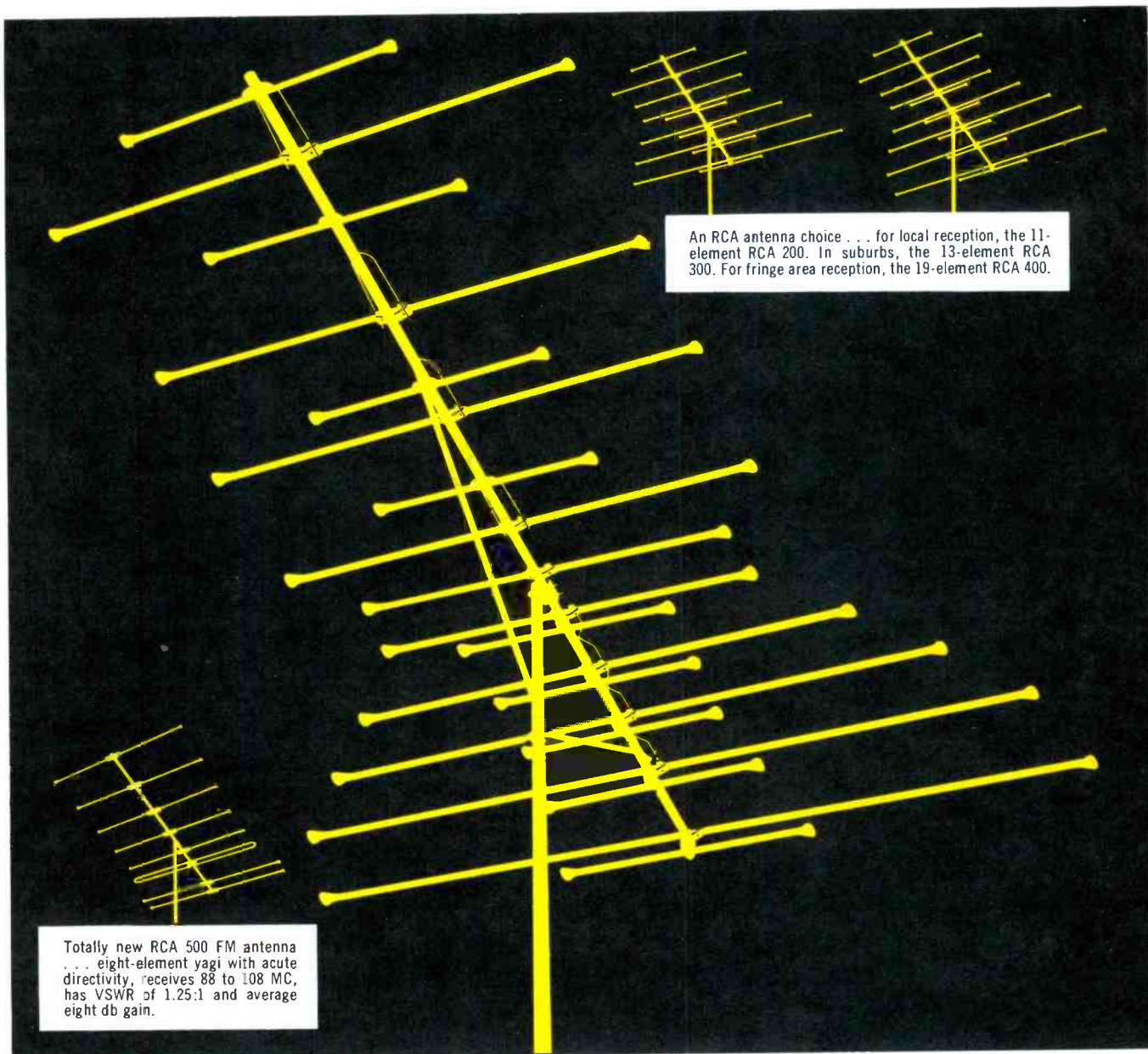

An RCA antenna choice . . . for local reception, the 11-element RCA 200. In suburbs, the 13-element RCA 300. For fringe area reception, the 19-element RCA 400.

Totally new RCA 500 FM antenna . . . eight-element yagi with acute directivity, receives 88 to 108 MC, has VSWR of 1.25:1 and average eight db gain.

RCA... Pioneer and developer of Color TV... Announces a new concept in outdoor antennas

Now the most trusted name in color TV brings you and your customers a whole new outdoor antenna line packed with top-value features. RCA puts together in a single line the best of all-channel yagi and multiple cross-driven element antenna types. You'll satisfy every customer's demand for sharpest color or black-and-white TV reception with this new RCA Series 200, 300 and 400 antennas.

RCA's electro-lens director system absorbs maximum incoming signal power, gives extremely high gain across



CAPACITIVELY COUPLED

the VHF band, offers excellent forward gain on the front end.

In addition to phasing low and high band directors for best high band performance, RCA and only RCA positions high band driven elements *directly below* low band driven elements.

Through capacitance thus existing, RCA antennas feed energy *directly* into the transmission line from high band driven elements. An RCA exclusive!

A permanent gold *anodized* finish defends every RCA antenna's glossy finish from weather corrosion. Wrap-around mast clamp aligns antenna on mast, prevents boom crushing.

Just call your RCA distributor. He'll tell you and show you all about new RCA 200, 300, 400 antennas . . . and that's *plenty!* Call now . . . sell soon!

RCA PARTS AND ACCESSORIES, CAMDEN, N. J.



THE MOST TRUSTED NAME IN ELECTRONICS

Circle 44 on literature card

October, 1963/PF REPORTER 71

"Let's make more money with Eico tube testers"

Every TV service technician should consider the extra service income and convenience possible with additional tube testers. An extra tube tester can more than pay its way in extra servicing income. Start with the new Eico 667 Dynamic Conductance Tester. Use it to spot and replace all weak tubes in every set that comes into the shop. It will pinpoint bad transistors too. It will ease repair problems and cut down on callbacks by pulling out bad or weak tubes with a short life expectancy. A rapid moving roll chart gives set up data quickly and a series of push buttons and lever switches put the tube through its paces in a hurry. Avoid having to replace a single tube a couple of days after making a \$25 or \$35 repair. Keeps you from looking careless.

Second, you need a topnotch emission tester, the new Eico 628. Take it with you on every call. Find the weak tubes in every set. Let the customer know that while you can get the set working again by replacing only one or two tubes, you can only guarantee reliable operation by replacing all the weak ones. Show him the difference between the weak tube in his set and the new one in your caddy. A glance at the big 4½-inch 3-color bad-weak-good scale will be a sure convincer. Tell him that by replacing the weak tubes your Eico 628 has located he's saving the price of a service call later on. Finally, by advising your customer of the weak tubes—"mark them right on the bill"—you

protect yourself against a callback, should one of these tubes go the very next day.

Finally, you should have an Eico 612 Filament Tester. Makes it easy to find the open heater in a series-string set without going out of your mind. The simple go-no-go indicator on the Eico 612 can't be misread. If the tube is bad, the indicator lamp won't light. Best of all, once the customer knows that tubes aren't at fault, you've got a service job. And at this point, the customer is already figuring on your pulling the set, no need to waste time explaining why.

Another convenient tool, is the new Eico 632 CRT Tester and Rejuvenator. It will show you and your customers when a new picture tube is needed. No question whether set or tube is bad. In many instances will add months of life to an aging picture tube. This will keep your customers happy and when the CRT does go, they'll come back to you for a new one.

PRICES: 667: kit \$79.95; wired \$129.95; 628: kit \$44.95; wired \$59.95; 612: kit \$4.95; wired \$6.95; 632: kit \$54.95; wired \$79.95. Add 5% in West.

Whether it's tube testers, VTVM's, scopes or any type of test instrument, you get the best for less with Eico. Save by building your instruments from kits, or buy them factory-wired at a substantial saving.

See your distributor. For complete catalog, write: PF-10



ELECTRONIC INSTRUMENT CO., INC., 3300 Northern Blvd., L. I. C. 1, N. Y.
EXPORT: ROBURN AGENCIES INC., 431 GREENWICH ST., N. Y. 13, N. Y.

Circle 45 on literature card

As the contrast was turned higher, bright horizontal lines appeared. They kept changing position, "following" figures and words in the scenes. A close inspection revealed they were caused by bunching of the raster lines. It looked like vertical linearity trouble except that the streaks kept changing position.

I didn't like to admit it, but I was puzzled again. The trouble looked as if it might be in the vertical sweep; still I wasn't sure of it. To kill time, I tried tube-changing in the vertical section, with no luck. I had removed the chassis to clean the oats out, so I was all set to do a little scope work in the vertical stages.

I'm not a scope expert. Yet, the waveform at the grid of the vertical output tube didn't look just right to me. Turning up the scope again, I could see distortion in the trace between the vertical spikes; the waveshape was changing as the scenes in the picture changed. Obviously, video information was getting into the vertical signal before it reached the grid of the output tube.

At this point, memory started to nudge my thinking. I remembered an old PF REPORTER article that dealt with the subject—"Let's Talk About Vertical Sweep" in the August and September, 1959 issues.

Checking through the pages, I learned that in some receivers the vertical blanking pulse was taken off at a point ahead of the vertical output grid. Occasionally, a weak or gassy picture tube could cause video information to feed back through the blanking circuit and upset the vertical sweep.

The recommended cure was to move the takeoff point to a lead of the vertical output transformer which had a pulse of the same polarity as the original takeoff point; and so I did. I also added an extra resistor in series with the blanking circuit to reduce the pulse to the same value used in the original circuit.

It worked! So I put a brightener on the CRT, made a few adjustments, bagged the oats, turned off the bench power, and started for home—wondering if it was all really worth it.

It is! ▲



what's it worth?

This is a typical PHOTOFACT TV Folder. What's it worth? Nothing, until you run up against a repair problem on this model.

Then, what's it worth?

We get a pretty good idea of what it's worth in reports we get (unsolicited) from PHOTOFACT users.

"Saved \$20 in time—ran down a cold solder joint in three minutes, thanks to your Standard Notation Schematic and resistance chart."

"Just fixed a job—sound bars in the picture. Used your alignment instruction chart and located the adjustment

on the chassis photo. Got rid of the IF detector buzz by following advice in the Field Servicing notes. Would have taken me an hour or more the hit-or-miss way."

"Licked my problem in a few minutes. Loss of horizontal hold. Checked tube failure chart. Trouble source not there. Checked the schematic—there it was—waveform at W17 and voltage reading at Pin 4 showed leaky coupling capacitor C78. This one Folder was worth \$10 to me."

You get PHOTOFACT at a cost of less than 1.5 cents per page—about 25¢

for this particular TV Folder. Users don't measure PHOTOFACT by its pennies-per-page cost. It's the *worth*—the time-saving, profit-making worth that counts.

Of course, you can get along without PHOTOFACT—a few do—and maybe they're making a living. But it's the hard way.

Doesn't it make good sense to see your Sams Distributor today for details on an Easy-Buy PHOTOFACT Library and Standing Order Subscription? Or use the coupon below.

SEND COUPON

ONLY \$10 DOWN puts the complete PHOTOFACT Library in your shop—no interest, no carrying charges, up to 30 months to pay. Special Free File Cabinet offer, too. And, to keep up with current industry output, sign up for a Standing Order Subscription to PHOTOFACT. See your Sams Distributor for full details or mail coupon.

FREE! VALUABLE PHOTOFACT INDEX

Send for it today! Your guide to over 56,000 TV, Radio, Electronics equipment listings. Covers virtually every model produced since 1946. Helps you locate the proper PHOTOFACT Folder you need to solve any service problems in any model. Send coupon today for your FREE copy of the latest PHOTOFACT Index to the service data you need.



HOWARD W. SAMS & CO., INC.

Howard W. Sams & Co., Inc., Dept. 7-K3
4300 W. 62nd St., Indianapolis 6, Indiana

- Send FREE Photofact Cumulative Index
 Send full information on Easy-Buy Plan
 Enter my Photofact Standing Order Subscription

My Distributor is _____

Shop Name _____

Attn. _____

Address _____

City _____ Zone _____ State _____

Circle 46 on literature card

October, 1963/PF REPORTER 73

UHF Antennas

(Continued from page 52)

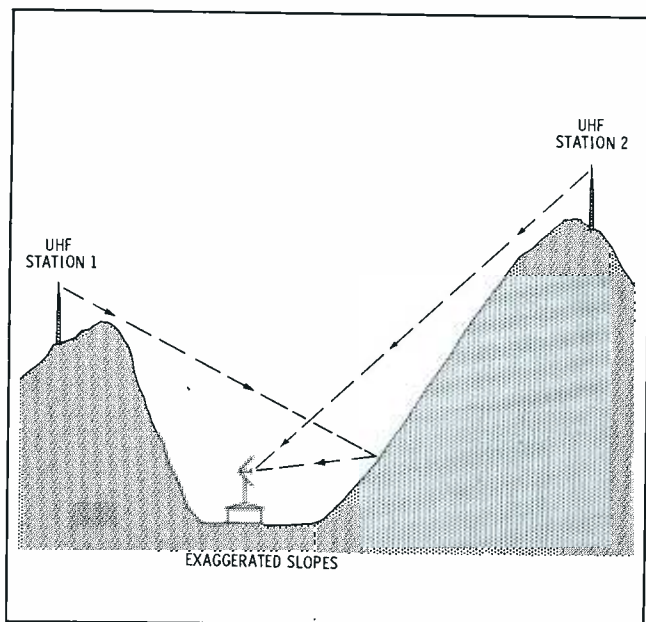

Fig. 4. Corner reflector unit improves vertical directivity.

row directivity of the yagi antenna is useful. There is one important consideration that may affect your decision to use a yagi antenna: Yagis are essentially narrowband antennas, and the frequencies of available stations may be farther apart than a single yagi will cover. If it is necessary to use a yagi, because of the absolute necessity of keeping a narrow frontal lobe, two of them — one for each station — can be stacked and phased into the same transmission line. Yagis will usually cover a band of eight or ten station channels at the low end of the band; at the high end, one yagi may cover twenty channels.

Another important consideration is the lobe itself. Being very narrow, the forward pickup pattern may shut out one of the stations even though the bandwidth of the antenna is sufficient. So, it is wise to plan carefully if yagis are to be used in any UHF installation.

Flying Vee

Not uncommon in near-fringe locations are the flying vee and the trombone type of antenna. The flying vee, sometimes called the "U-V," is a very simple unit that provides coverage of both UHF and VHF frequencies. It resembles two large, square-cornered "U's" fastened together at the "bottom," and then placed on their side with the legs vee'd out facing a station. The trombone is somewhat similar, but has several vee's connected together along a trombone-shaped aluminum phasing bar. Both units are broadband antennas, with no great gain; the front-to-back ratio is low, making them work best only in ghost-free areas.

'Way Out

For fringe and extreme fringe reception, high gain is of the utmost importance. Consequently, antennas used for reception of distant UHF signals are designed with extreme sensitivity in mind, along with a reasonably good front-to-back ratio.

Stacking of the antenna types already described is a frequently used method of attaining the extreme gain needed in deep fringe areas. You'll sometimes see the four-bow unit stacked in side-by-side and over-under configurations—sometimes with as many as 12 bays. These are connected together by phasing harnesses to feed a single 300-ohm (sometimes 75-ohm) lead-in.

Collinear Arrays

Certain types of collinear arrays—banks of dipoles, each with a reflector—have been used effectively for fringe signals. The dipoles and their phasing bars, which are usually of the same material, give the appearance of a bedspring—a name sometimes used for this antenna. It resembles the collinear antennas of early VHF days, but is physically much smaller.

As more dipoles are added to the array, the pickup lobe becomes more narrow, and the gain increases. The front-to-back ratio of these antennas is usually excellent, due to the cumulative effect of the several reflectors; they form a sort of UHF screen behind the active elements.

Parabolic Units

The frequency of UHF stations is high enough, especially near the high end of the band, and the wavelength short enough, that a parabolic reflector can be used to concentrate UHF energy into a very intense beam. For far-fringe reception, especially at the high end of the UHF band, these units have proved very popular. They are being used in the Midwestern area of the country to receive signals from the MPATI airplane that televises instruction to schoolrooms of several states on channels 72 and 76 (see "MPATI at Midterm" in the January, 1963 issue).

The gain of one parabolic antenna model reaches 18.5 db at the high end of the UHF band. This high gain helps minimize fading that is not uncommon to far-fringe UHF reception.

Care is necessary in locating these high-gain, narrow-beam units. Their size demands a staunch support; the parabolic "dishes" range from 4' to 7' in diameter. Their beamwidth—some as narrow as 19°—dictates careful attention to location and orientation; a field-strength meter is almost a must to install an antenna of this sort in a spot where there are no signal cancellations.

Summing Up

All in all, the technician who learns to select an antenna intelligently, and install it carefully, is the one who will profit from this new "boom." There is little need to choose a high-gain antenna, when a less expensive type will do just as good a job for a particular location. The key is in becoming familiar with the reception characteristics of various UHF antennas, and applying your knowledge wisely.

Thoughtful application of the facts in this article will permit neat, reasonably priced, and effective installations that satisfy your customer's two prime requirements—an attractive installation, that will pull in a good signal. With your help, UHF telecasting will thus finally come of age and fulfill its intended goal—more and better TV for many more viewers. ▲



Here's the **NEW** Jensen **Concert-Fidelity Series** ^{T.M.}

MR. SERVICE DEALER:

When you need a loudspeaker with substantially higher fidelity than you can get with general-purpose units, you'll find just what you want in Jensen's new CONCERT-FIDELITY Series. It is an important part of Jensen's new complete speaker line available from your distributor.

Special cone supports, made of cloth, improve bass; there are coaxial speakers offering increased clarity of speech and music; multi-way units and crossover networks let you tailor sound quality to meet special requirements (there are more than 500 custom combinations possible). Binding-post terminals make installation fast and easy.

Get the full story—send for Catalog 1090 today.

MODEL NO.	TYPE	SIZE	FREQUENCY RANGE	IMPED. OHMS	POWER RATING†	LIST PRICE
DC-80	High-Compliance Full Range, Dual Cone	8"	40-16,000	8	11 w.	\$19.95
DC-120	High-Compliance Full Range, Dual Cone	12"	25-13,000	8	13 w.	22.95
KD-80	High-Compliance Two-Way Coaxial	8"	30-15,000	8	12 w.	28.25
KD-120	High-Compliance Two-Way Coaxial	12"	20-15,000	8	14 w.	33.25
W-80	High-Compliance Woofer	8"	30-2,000	8	15 w.	19.25
W-120	High-Compliance Woofer	12"	20-2,000	8	18 w.	22.25
W-150	High-Compliance Woofer	15"	20-2,000	8	20 w.	33.25
M-81	Midrange, Closed-Back	8"	600-4,000	8	25 w.	14.80
TW-350	Direct Radiator Tweeter	3½"	2,000-15,000	8	15 w.	5.95
TH-100	Compression Tweeter	—	1,000-16,000	8	25 w.	19.95
TH-200	Compression Tweeter	—	2,000-18,000	8	25 w.	17.80
XN-100*	2-Way Crossover	—	2,000 cycle Crossover	—	—	15.50
XN-200*	2-Way Crossover	—	2,000 cycle Crossover	—	—	15.50
XN-640*	3-Way Crossover	—	600/4,000 cycle Crossover	—	—	19.95

*Complete with H-F Control

†Program rating. Peak power is twice the indicated figures.



JENSEN MANUFACTURING COMPANY / DIVISION OF THE MUTER COMPANY / 6601 SOUTH LARAMIE AVENUE, CHICAGO 38, ILLINOIS
Canada: Radio Speakers of Canada, Ltd., Toronto • Argentina: Ucoa Radio, S. A., Buenos Aires • Mexico: Fapartel, S. A., Naucalpan, Mex.
Circle 47 on literature card

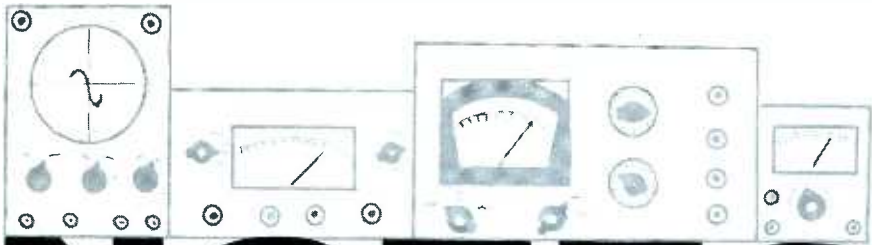

NOTES ON TEST EQUIPMENT

by Forest H. Belt

Kit-Form Stereo Generator

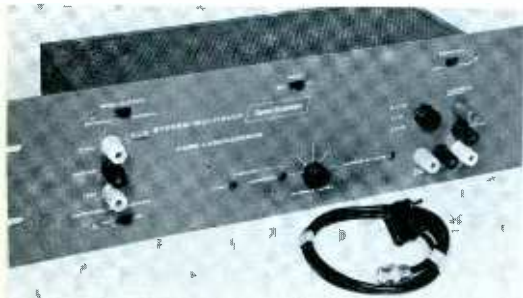

Fig. 1. Stereo FM signal generator can be mounted in regular 19" metal rack.

The instrument shown in Fig. 1—the Karg Laboratories Model MX-1G Stereo Multiplex Signal Generator—is suitable either for rack mounting or for service-bench use. It provides test signals for servicing and aligning stereo FM adapters and receivers.

Specifications are:

1. Power Required—117 volts AC; 60 cps; 50 watts.
2. RF Output—None.
3. Composite Stereo Output—From 0 to 15 volts peak to peak, continuously variable; output impedance, 600 ohms; single-tone modulation of either channel alone, of both channels with right channel 180° out of phase, or of both channels in phase; with or without 19-kc pilot carrier; less

than 1% distortion.

4. Internal Signals—Single 1000-cps tone for modulating either or both audio channels; crystal-controlled 19-kc (within ± 2 cps) pilot carrier, adjustable to as high as 15% of composite-signal amplitude.
5. External Signals—Provision for feeding in SCA signal, requires 3 volts rms for 10% SCA modulation; external audio for L and R channels, 10 volts rms (14 volts peak to peak) for full composite signal, frequency response ± 1 db from 40 to 15,000 cps.
6. Controls and Terminals — rotary L and R mode switch; MODULATION, PILOT, CHANNEL, and OFF-ON slide switches; OUTPUT LEVEL potentiometer; PILOT PHASE, PILOT AMPLITUDE, and CARRIER BALANCE screw-driver controls; left and right EXTERNAL MODULATION input terminals; PILOT SYNC, AUDIO SYNC, and COMPOSITE SIGNAL output terminals; three GROUND terminals; pilot lamp.
7. Size, Weight, Price—5" x 19" x 5½"; approximately 10 lbs; \$250 cabinet mount, \$255 rack mount, \$150 kit form.

The Model MX-1G is one of the first stereo generators to be offered in kit form. Although signals from the unit cannot be fed into the front end of a

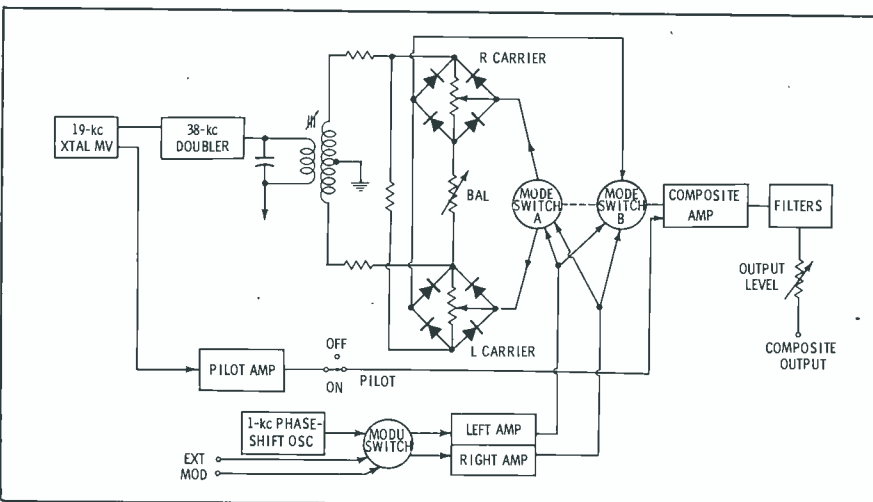

Fig. 2. Pair of bridge rectifier circuits form unusual balanced modulator.

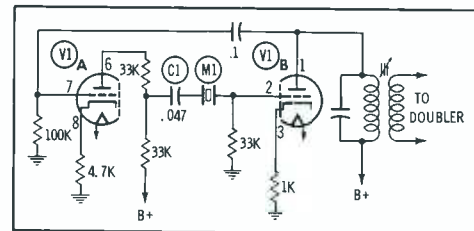

Fig. 3. Crystal-controlled multivibrator generates 19-kc control signals.

stereo FM receiver or tuner, it is a simple matter to connect the composite signal directly to the input of a stereo adapter. In receivers that include the stereo multiplex circuits, the Model MX-1G can be connected at the output of the sound demodulator (usually a ratio detector).

The key stage in any stereo generator is the 19-kc oscillator, for all other actions of the unit are controlled by the pilot signal generated in this circuit. In the Model MX-1G, the 19-kc oscillator is a crystal-controlled multivibrator—the first stage at the upper left in Fig. 2.

A detailed schematic of this stage is shown in Fig. 3. The circuit configuration is that of a simple cross-coupled multivibrator, with one notable addition: 19-kc crystal M1 is part of the coupling capacitance, along with capacitor C1. Because of the resonant frequency of M1, only 19-kc energy can be coupled from V1A to V1B. Thus the multivibrator can operate only at 19 kc, the precise frequency of the pilot carrier in the stereo FM signal.

Getting back to Fig. 2, and the overall operation of the MX-1G, you'll notice that a portion of the 19-kc signal is sent to the 38-kc doubler, while part is fed to a 19-kc amplifier. The signal from the doubler is coupled via a tuned, balanced-secondary transformer to a pair of bridge rectifier circuits, operating as balanced modulators.

It is characteristic of balanced modulators that only sidebands appear in the output; that is, the carrier signal is suppressed. Therefore, when audio or stereo signals are fed to the balanced modulator bridges along with the 38-kc signal, only the sidebands of the signals will be passed to the output stage. We'll explain the part played by the mode switch, in just a moment.

First, notice the sources of audio signal. A single 1000-cps signal, developed internally by a phase-shift oscillator, can provide—via the modulation switch—an in-phase signal for both channels or a signal for the right channel that is 180° out of phase with that in the left. The former combination is actually a monophonic signal, while the latter is an excellent test signal for checking and comparing operation of the right and left channels in a receiver. As an alternative, a pair of inputs from an external source can be connected—via the modulation switch—as either a stereo or mono signal. Whatever the source or mode of audio signal, the output is fed to one corner of each balanced-modulator bridge.

The mode switch determines which audio-channel signal is received by which bridge circuit. By this arrangement, the

most successful profit-producing UHF combination is coming to your city



If you're located in a city where UHF channels are on the air, then you know Blonder-Tongue. If you're in an area that is soon to go UHF, now's a good time to get acquainted with the UHF profit-producing magic associated with Blonder-Tongue. Take a good look at this total selling approach to UHF.

1. BLONDER-TONGUE ALL-CHANNEL UHF CONVERTERS Performance proved in 2,000,000 American homes.

MODEL 99-S Popularly priced converter for prime signal areas. Stable and UL approved. For customers up to 20 miles away from the station. **List \$27.95.**

ULTRAVERTER BTU-2T all-channel UHF converter. Most powerful converter engineered for the home. Doubles signal power (5 to 8 db gain). **List \$41.35.**

2. SENSATIONAL NEW BLONDER-TONGUE U/BOOST INCREASES UHF PROFIT ZONE First All-Channel UHF booster. Triples antenna signal voltage. Teams up with a UHF converter or all-channel receiver, to improve UHF reception on any channel 14 to 83. **List \$34.95.**

3. POWERFUL BLONDER-TONGUE MERCHANDISING ASSISTANCE Repeat the selling successes of other Blonder-Tongue dealers in every UHF area throughout the country. Sales aids and ads are tested, and Blonder-Tongue gives you complete promotional package: newspaper ads with dealer listings; TV Guide ads; ad mats; stuffers; window streamers.

Look to the leader in UHF for the big profits. See your Blonder-Tongue distributor, or write:

BLONDER-TONGUE
9 Alling St., Newark, 2 N. J.

Circle 48 on literature card

THE COMPTROLLER FAINTED DEAD AWAY! THE SALES MANAGER DANCED A JIG!

SEE WHY?

Suggested list \$554.60 200 of the fastest selling Westinghouse receiving tubes.

Suggested dealer price 99.95 Portable tube checker

~~\$654.55~~

Your special price \$261.82 Limited time.

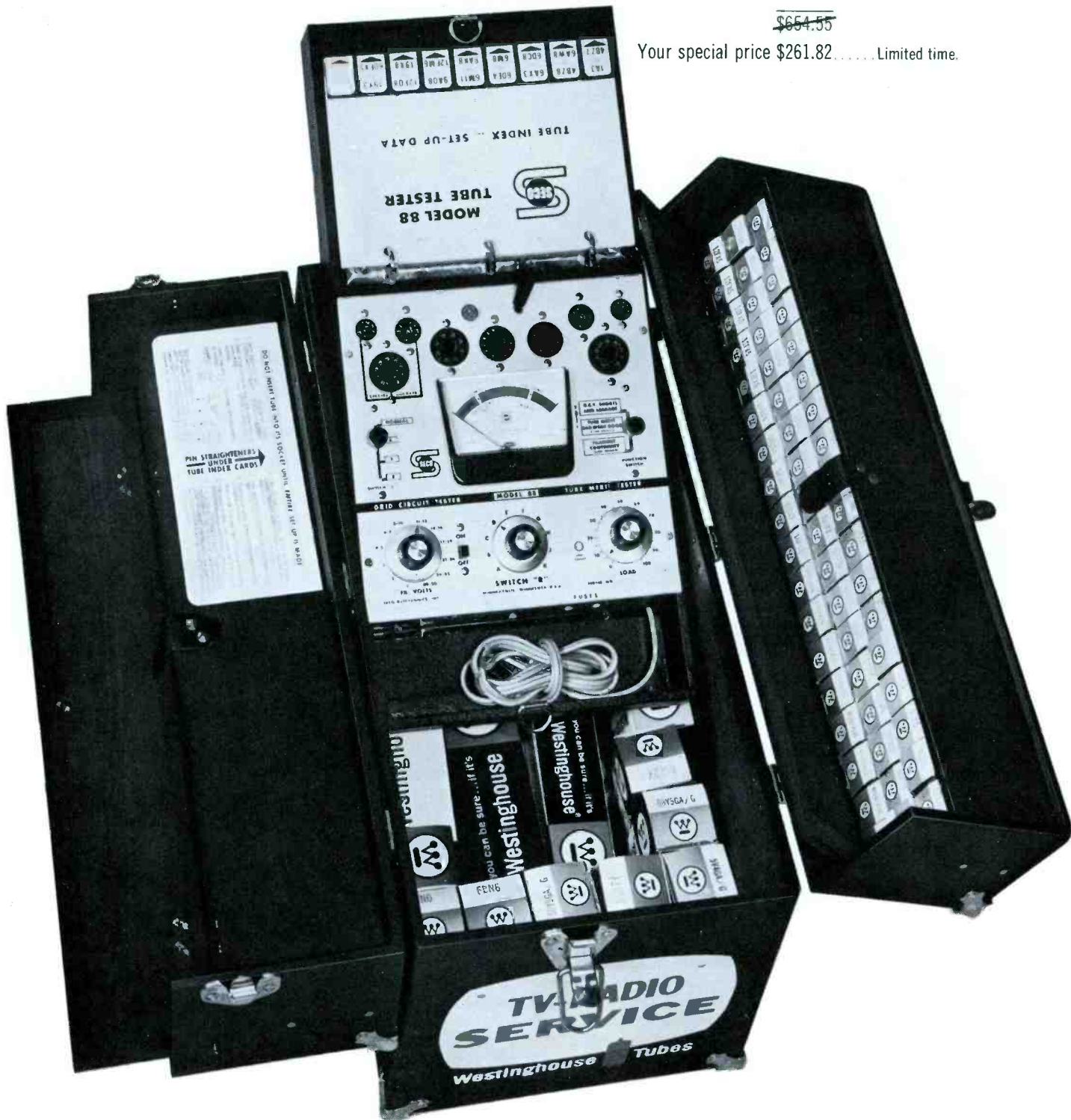

Circle 49 on literature card

Almost a \$400 savings!

200 fast-moving Gold Star receiving tubes; sturdy caddy and new-design checker all for \$261.82. You get three things—each made in the U.S.A.—checker, a caddy and 200 Westinghouse Gold Star receiving tubes—at 60% off list.

The tube checker is a handy piece of equipment. It's portable. Checks both receiving and picture tubes—domestic or foreign. Sturdy carrying case also serves as a tube caddy.

Strip the offer to its bare bones...

... and you find nothing but pure gold. Proof is the quality of the tubes. Here are the types. See for yourself.

12—5U4GB	3—12BH7A
11—6CB6A	3—6BZ7
10—6BQ7A	3—12BE6
9—6SN7GTB	3—6X8
8—6AX4GTB	3—6AU4GTA
7—12AU7A	3—6AW8A
7—6CG7	3—6CD6GA/G
7—6U8A	3—6BZ6
7—50C5	3—12AX4GTB
7—1K3/1J3	3—12BY7A
6—6AU6A	3—12DQ6B/A
6—35W4	3—6J6A
6—6BQ6GTB/6CU5	3—1X2B
6—6DQ6B	3—6BK7B
6—6AQ5A	3—5U8
5—0Z4	3—6T8A
5—12AX7A	3—6S4A/6S4
5—12AT7	3—6CM7
5—12BA6	3—6V6GTA
5—6AL5	3—12AV6

For the sake of your bank balance - act now!

Your nearby Westinghouse Appliance Sales distributor is waiting to hear from you. Look him up in the phone book. Or write direct.



Westinghouse Appliance Sales

300 Phillippi Road, Columbus 16, Ohio

mode switch can select a balanced-modulator output that contains: sidebands of both L and R signals, sidebands of either L or R signals, or sidebands of a signal in which the right channel is 180° out of phase with the left. In all cases, the 38-kc subcarrier is suppressed. You'll notice the mode switch has two sections; stated simply, one section arranges the connections for the balanced modulator, and the other makes connections to the composite amplifier.

From the balanced modulators, the L-R sideband signals are fed to the composite amplifier, where they are mixed with the direct L and R signals and with the pilot carrier. Additional filter networks help remove any 38-kc subcarrier that might remain with the sideband signals, and the composite stereo waveform is fed through a level control to the output terminal.

The MX-1G, like most stereo generators we've used for multiplex alignment in our lab, gave best results when we used a scope to actually "see" the stereo signals. The terminals provided for external scope sync were a considerable advantage, enabling us to set up scope traces that locked solidly, with no jitter or creeping.

Recessed screwdriver controls on the front panel provide for certain maintenance adjustments, and allow instantaneous checking of the accuracy and phasing of the instrument. A scope and a screwdriver are all that is needed to correct any slight error, so the adjustments can be easily checked each time the instrument is used. We made one very slight adjustment to the pilot phase control when we first began using the unit, but regular checking failed to disclose any need to readjust any of the controls, even after repeated use. We obtained the most consistent scope indications, however, by allowing the unit to warm up for a half-hour before using it for alignment.

The instruction manual shows waveform photos of the various signals provided by the unit. These can be a helpful aid to understanding stereo alignment; in addition, they offer excellent clues to any trouble that might occur during alignment. Careful study of these waveforms will pay dividends in quicker troubleshooting and servicing.

For further information, Circle 80 on literature card.

Metering Low-Level Audio

For measuring the audio signals generally encountered in public address and hi-fi systems, the Heath Model IM-21 AC VTVM (Fig. 4) includes ranges to measure signal voltages at all levels from preamp input to power amplifier output.

Specifications are:

1. Power Required—105-125 volts AC; 50-60 cps; 10 watts.
2. Audio Voltmeter—From 0 to .01, .03, .1, .3, 1, 3, 10, 30, 100, and 300 volts rms; accuracy, ±5%; frequency response ±1 db from 10 cps to 500 kc, down 2 db at 1 mc.
3. Decibel Meter — Ten ranges from

ONLY

99 95 NET



FOR SPEED AND CONVENIENCE
SECO MODEL 88TC
CADDY PACK TUBE TESTER



- Carries over 200 tubes to the job with you
- Includes an adaptation of the proven Seco Model 88 tester
- Tests over 400 picture tubes including 110° deflection types
- Unconditionally guaranteed up-to-date for all receiving tubes including new novars, nuvistors, 10 pin types, compactrons and magnovals.

You get ample storage in the Caddy Pack's 9 1/4" x 15 1/4" x 19 1/4" case. It opens from the center with two enclosed areas on the sides and a large area below the tester.

You'll like the tester for its simple, rapid operation—even checks cathode ray tubes. For receiving tubes, meter reads grid emission and all common leakage and short faults in one step. Filament continuity and open elements are also indicated as well as cathode emission in a special low impedance circuit. Grid circuit and tube merit test scales show all tube faults quickly and accurately on a single burnout-proof meter. Grid Circuit Test is patented by Seco.

Caddy Pack is ideal for hotels, hospitals and institutions having a number of similar TV sets or radios—handy for regular service work, too.

For more information on the Model 88 Tester, see the Seco advertisement on page 85.



SECO ELECTRONICS, INC.

1221 S. Clover Dr., Minneapolis 20, Minn.
A DIVISION OF DI-ACRO CORPORATION
Circle 85 on literature card

October, 1963/PF REPORTER 79

**Anyone
can install
a MOSLEY
TV-FM Antenna
System !!**



Mosley FG-1PK

Here is a TV/FM receptacle designed to make every room a family room. Mosley engineered to fit popular interchangeable type electrical plates and straps. Now the AC and TV/FM outlets can be matched to fit any room decor. Convenient - Set can easily be moved for enjoyment in other rooms. Mosley FG-1PK combines efficiency with neatness and ease of installation in one compact outlet. Comes complete with mating polarized 303 plug. Available in brown and ivory to match interchangeable plates.

MOSLEY FG-1PK

List \$.99

**MOSLEY HAS A COMPLETE LINE
OF TV/FM ACCESSORIES
DESIGNED AND ENGINEERED TO
PROVIDE BETTER TV/FM
RECEPTION THROUGH A BETTER
INSTALLATION!**

FREE  **FREE**

Please send me your catalog containing the complete line of TV/FM installation accessories.

Name

Address

City/State

Mosley
Electronics Inc.

4610 N. Lindbergh Bridgeton Mo.
Circle 52 on literature card



Fig. 4. IM-21 meter is calibrated to read either decibels or voltages.

- 52 db through +52 db; zero reference level 1 mw in 600 ohms.
- 4. *Input Impedance* — 10 megohms; shunted by 22 mmf on .01 volt through 3 volt ranges; shunted by 12 mmf on 10 volt through 300 volt ranges.
- 5. *Panel Meter*—Face size 4½"; sensitivity 200 ua, 1400 ohm movement; decibel scale -10 to +2, voltage scales 0-3 and 0-10.
- 6. *Controls and Terminals* — Rotary RANGE and power switch; INPUT and GROUND combination-type terminal posts.
- 7. *Size, Weight, Price*—7¾" x 4 11/16" x 4½"; 3 lbs; \$33.95 kit, \$60.25 wired.

The Model IM-21 is an amplified-type vacuum-tube voltmeter, in which minute audio voltages are built up to a level that will permit indicating their value on a meter of practical sensitivity. Thus, a 200-ua meter movement can be used to measure rectified audio voltages at levels considerably lower than would be possible without the amplifiers.

Fig. 5 shows the operating sections of the unit. The input signal is fed into one section of the range switch, which is wired as a frequency compensated attenuator. Following this, a cathode follower feeds the second section of the switch. A cathode follower is used because its gain, which is slightly less than one, is relatively constant throughout varying input and output load conditions. Thus, the compensated attenuator sections, in conjunction with the constant-gain cathode follower, provide an extremely dependable control over the exact amount of signal fed to the dual-stage pentode amplifier.

Pentode amplifiers are chosen for their stability and high gain. Their operating characteristics are carefully chosen and controlled to provide exactly the amount of constant amplification needed. In conjunction with the bridge rectifier—which is part of the plate load for the final pentode—is a feedback circuit which essentially determines the overall gain of the two stages. The calibrate control is connected in this feedback loop to allow setting the gain precisely.

The bridge circuit used in this VTVM is not the bridge-type metering circuit

commonly associated with VTVM's. In this unit, the bridge is merely a full-wave rectifier that converts the audio signals to DC readings that can be indicated on an ordinary microammeter.

Fig. 6 shows a simplified schematic of the rectifier load circuit and the calibration feedback loop. Coupling capacitor C2 transfers the output signal from the last pentode tube to the bridge rectifier and R3. Thus, R3 develops a portion of the output signal, which is then fed back to the first amplifier. R2 and R1 determine the amount of feedback applied to V1; R1 sets the practical minimum, while R2 is adjustable and controls the overall gain of the two-stage amplifier.

We used the Model IM-21 in our lab in a number of ways. In addition to its prime use as a measuring device for audio voltages, we found other uses. Its extreme sensitivity enables checking the output of phonograph cartridges and microphones directly, and its flat response permits its use for developing response curves for these components. We could even plot directional characteristics for each of our microphones.

Although plotting directional characteristics accurately requires a completely reverberation-proof chamber, we were able to develop some useful curves by performing our measurements outdoors. With no wind to throw readings off, we found it practical to use a single sound source that could be moved in a 360° circle around the microphone being tested. The Model IM-21 was connected directly to the microphone and the output voltage plotted on a polar graph. The results, while not equalling those taken in an anechoic chamber, were practical.

As a signal-tracing device the IM-21's

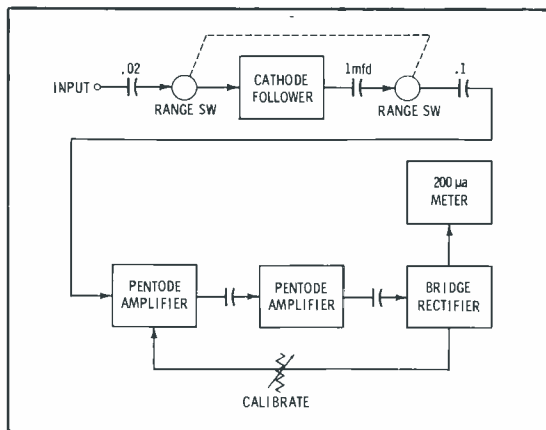

Fig. 5. Feedback loop has calibration control for accurate gain adjustment.

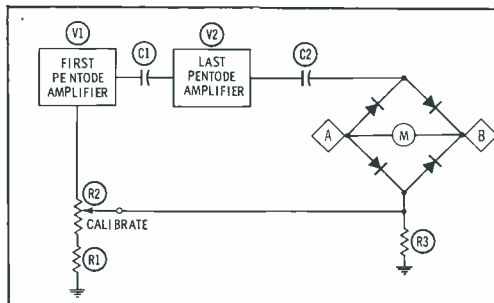
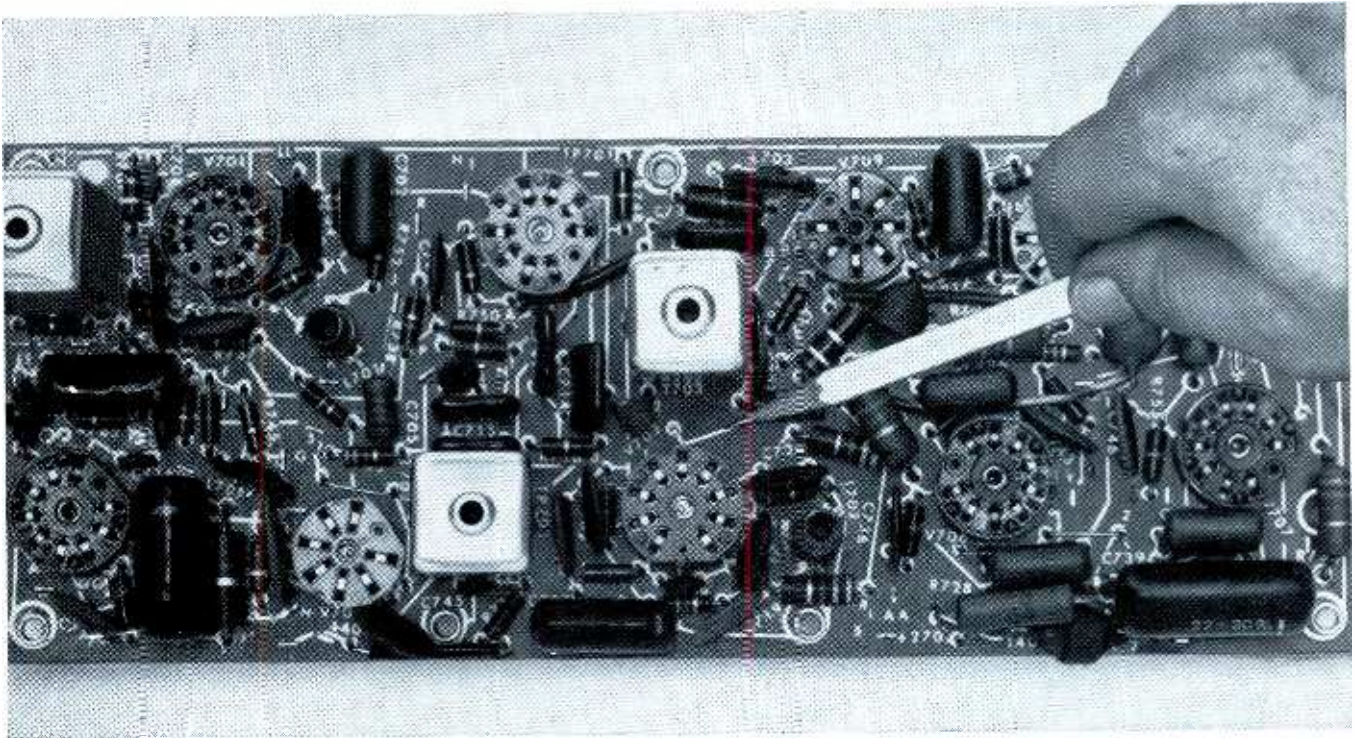

Fig. 6. Bridge circuit is used to convert amplified audio signals to DC.

From RCA Victor—another big advance in Space-Age Sealed Circuitry



RCA Victor Color TV Chroma Circuitry

You can see at a glance how new streamlined “road-mapping” makes servicing faster, easier, surer than ever before

Pictured above is the “new look” in RCA Space Age Sealed Circuitry . . . the new precision-crafted boards that you’ll see in *all* 1964 New Vista Color and in most RCA Victor black-and-white television sets for 1964.

This new schematic diagram “road-mapping” consists of *straight white lines* that run *directly* from *point-to-point*. No confusion, no difficult paths. And the extra space gained has been used

to make the label markings larger. You can see and trace the circuits at a glance.

Here again RCA Victor has made a vitally important contribution to easier, faster and more accurate servicing. It is part of our continuing research program to offer the utmost in reliability with Space Age Sealed Circuitry.

See Walt Disney’s “Wonderful World of Color,”
Sundays, NBC-TV Network



The Most Trusted Name in Electronics

Tmk(s)®

Circle 18 on literature card

October, 1963/PF REPORTER 81

sensitivity again makes it useful in a number of applications. Although its response is reduced at RF frequencies, it is adequate for tracing in broadcast receivers, and is especially adaptable to use in transistor sets. We found we could check comparative gain in RF, IF, and audio transistors without regard for actual frequency.

Initial calibration proved to be the key to accurate readings, because once the unit was calibrated properly we found it to be accurate in all its ranges. An approximate calibration can be made using line voltage; but because of line voltage fluctuations, we made doubly sure of the calibration by using the calibrated output from a lab generator. Following Heath's instruction manual, we fed a 3 volt, 1000 cps signal into the IM-21 and adjusted the CALIBRATE control for an exact full-scale reading on the 3 volt scale. Then switching to the 10 volt scale, we adjusted the compensating trimmer for an exact 3 volt reading again. After these adjustments were carefully made, the accuracy was well within specifications over all the other ranges.

The decibel scales of the IM-21 are computed in power ratios, not in voltage ratios. While the voltages measured by the instrument are accurate in almost any practical circuit, the db readings are accurate *only* if they are taken in a circuit with a 600-ohm impedance. Zero db is equal to 1 mw in 600 ohms, and the voltage equivalent would be about .77 volt measured across the 600-ohm load. However, the meter could read .77 volt across a 1000-ohm load, and the true power would be only .6 mw; thus, it is necessary that decibel readings—to be accurate—must be taken only across a 600-ohm impedance.

The decibel scales make direct gain comparisons possible. Gain can be computed by measuring the input and output power, and converting their ratio to db. But with the IM-21 this conversion isn't necessary; the db scales can be used to measure power gain directly. For example, if the input to an amplifier stage is -20 db on the meter and the output measures +10 db, the amplifier power gain is obviously 30 db.

If a voltage-gain figure is more useful, the instrument can be used to measure the input and output voltages, and their ratio easily computed. For example, if the input to an amplifier stage is 100 millivolts (.1 volt), and its output is 10 volts, the voltage gain is 1000; the decibel equivalent would be 60 db of voltage gain.

For further information, Circle 81 on literature card.

Liven 'Em Up!

The practical serviceman is frequently faced with the question of whether to replace a weak television picture tube, install a brightener, or try "bringing it back to life" with a rejuvenator. SENCORE Inc. has developed a combination CRT tester and rejuvenator that can help him make a more accurate decision—the Model CR125, pictured in Fig. 7.

Specifications are:

1. Power Required—117 volts AC; 60 cps.
2. Tests Performed — Shorts; leakage and/or gas, sensitive to 25 megohms; cathode emission; probable life.
3. Tubes Tested—All television picture-tube types, including newest-type color CRT's.
4. Other Features—Repairs shorts between elements; reactivates cathodes of weak and borderline CRT's, with automatically controlled timing of reactivation period; each gun of color CRT's reactivated separately; compartment for storing test and power cables; in steel carrying case at no extra cost (Model CR128).
5. Panel Meter—Face size 3½"; sensitivity 500 ua, 300 ohm movement; accuracy ±2%; Bad?-Good scale.
6. Controls and Terminals—rotary power and filament switch; rotary FILAMENT voltage switch; GRID BIAS potentiometer; LIFE TEST, G2, and COLOR GUN slide switches; REJ (rejuvenate) push button switch; two neon SHORTS indicators; neon pilot lamp; all CRT sockets on one test cable.
7. Size, Weight, Price—10" x 10½" x 4¾" overall; 9½ lbs; \$69.95.

When he encounters weak or no video, or a faulty raster, the service technician is often at a loss to find a quick method to evaluate the picture tube quickly and accurately. He may use the time-consuming process of elimination by servicing the chassis first, but this is not the best way to realize a profit. A quicker way is to make a conclusive test of the CRT itself, and proceed from there.

The Model CR125 is designed to do just that—provide a conclusive test for a questionable CRT. But this instrument goes even further; if the CRT tests defective because of a short or leakage, the CR125 has a circuit for removing shorts. If low emission is the problem, a special rejuvenation arrangement is pressed into service. In our lab, we ran through the entire procedure of using the CR125 on some of our faulty CRT's. Let's recap our findings, and include some side comments on CRT testing and rejuvenation in general. From this, you will get some idea how the unit functions.

We began the same as you would if you suspected a customer's picture tube of being defective. With the FUNCTION switch "off," we set the filament voltage according to the setup chart furnished with the instrument. If the tube hadn't been listed in the chart, we could have consulted a tube-data book for the correct voltage, and set the FILAMENT switch accordingly.

Next, we set the G2 switch according to the chart. Again, this switch can be set from published data. If G2, the accelerating anode, is designed to operate at a low voltage (around 50 volts, as opposed to the 150 volts or more used in other CRT's) damage could result if this slide switch were left in the HI position. It is advisable to set this switch during the preliminary procedure.



Fig. 7. New instrument is capable of rejuvenating color guns, one at a time.

We left the GRID BIAS control at zero for all preliminary testing, and rotated it later when it was needed for the emission test. This was for two reasons: First of all, the grid bias is inconsequential during shorts tests. Furthermore, switching the FUNCTION switch can cause the meter to "pin" when moving through certain settings; keeping the GRID BIAS control at minimum can alleviate this annoyance, and prevent possible meter damage.

The shorts and leakage tests should be made first, so we set the FUNCTION switch to SHORTS. Sometimes it is wise, in the case of a suspected intermittent, to tap the neck of the CRT while this test is being made. If a short, or excessive leakage, is present within the tube, one of the neon indicators on the panel of the instrument will light. In the case of direct shorts, the lamp will glow brightly; with slight leakage or gas, the lamp will glow more weakly, often with a rapid flashing. In one of our CRT's, a grid-cathode leakage that measures on a lab tester in the order of 8 megas was revealed by the CR125; both neon lamps glowed dimly, flickering at a very rapid rate.

A chart in the instruction booklet describes how to identify the exact nature of the short by noting the action of the neon lamps. If the short is from heater to cathode, the tube may still be used in heater circuits that are isolated from ground; in other circuits, an isolation transformer of some sort will be necessary if the tube is to function properly. The other alternative, of course, is to replace the tube.

Grid-to-cathode shorts can sometimes be removed by the CR125; at least, there is little to be lost by trying—if

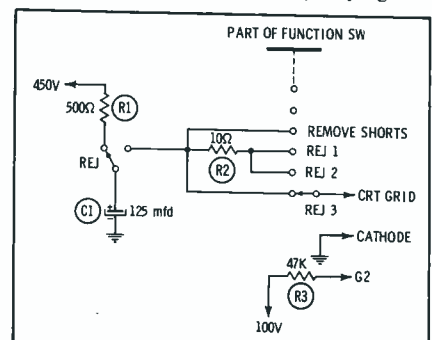

Fig. 8. Rejuvenation period is controlled by special RC timing network.

the try fails, the tube would have to be replaced anyway. If the neon lamps glow, you'd then switch the FUNCTION selector to REMOVE SHORTS and depress the REJ button. If the short is repairable, the unit will "burn" it out. Occasionally, a flash within the CRT gun will result from this step; if so, release the button and press it again to reapply the voltage. Moving the selector switch back to the SHORTS position will indicate whether the short has been removed.

Another excellent idea, when attempting to repair a picture tube, is to first resolder all the base-pin connections. A number of filament and cathode opens can be repaired by this simple procedure. Occasionally, too, a short circuit will have occurred because of a solder "whisker" inside the tube, and the resoldering will dissolve it. If resoldering isn't the answer, then proceed with the shorts-removal and rejuvenation procedures, using the CR125.

Checking the emission of the CRT is as simple as moving the selector switch to EMISSION, after making sure the G2 switch was set correctly. The panel meter indicates the condition of the cathode on a GOOD-?-BAD scale.

We tried rejuvenating one of the weak CRT's from our group of duds. The SENCORE unit has an interesting innovation called ACR, for Automatic Controlled Rejuvenation. Some CRT re-activators include timed rejuvenation periods, often by using relays; the Model CR125 contains an RC circuit that automatically limits the rejuvenation time according to the actual condition of the CRT. Fig. 8 shows, in simplified form, how this is accomplished.

In its resting position the push-button REJ switch connects rejuvenation capacitor C1 across 450 volts, allowing it to charge through R1. When the button is depressed, the voltage across C1 is applied to the CRT grid; the discharge time depends on the amount of current thus drawn by the defective tube. If beam current from the cathode is high, indicating a fairly good tube, the capacitor discharges quickly and prevents over-rejuvenation. If the current is low, a sign of weak emission, the decay time is slower and the rejuvenation voltage remains for a longer period. Besides this, if the cathode is open, the high voltage will often weld the break; the current surge that occurs during the arc discharges the capacitor and prevents sustained beam current which might reopen the cathode.

A careful examination of the simplified schematic of Fig. 9 along with Fig. 8 will show the three degrees of rejuvenation available in the CR125. For all three, 100 volts is applied to G2 through the comparatively high resistance of R3; this resistor holds the total beam current within a safe limit during rejuvenation. In the REJ 1 position, filament voltage is normal, and the rejuvenation voltage is applied to the grid through limiting resistor R2; this is the setting to try first. If one shot of REJ 1 fails to bring the emission reading above the questionable area on the

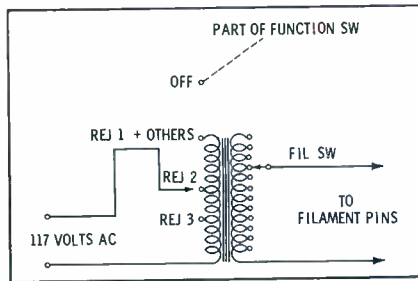

Fig. 9. "Life-test" filament voltage is set by tapped transformer primary.

meter, try REJ 2. In this position, the filament voltage is increased about 35%, and the grid again receives the "shot" through the limiting resistance of R2. If one shot of this fails, REJ 3 is the

last resort.

In REJ 3, the filament voltage is nearly doubled—a procedure which, in itself, may "finish off" a weak CRT. However, if the tube is bad enough to need a shot from REJ 3, it probably wasn't viewable and would need replacing anyway; so again there's little to lose by trying. REJ 3 applies the full capacitor charge directly to the grid. If the tube can be reactivated, this "shot" of excitation—accompanied by the greatly increased cathode temperature—will do it. If it doesn't, you can assume that you've done everything possible, and proceed to replace the tube. ▲

For further information, Circle 82 on literature card.

every
word
clearly
heard

with the **Ampli-Vox**
ROVING[®]
ROSTRUM

*A complete high volume
sound system in a
single case!*



- Powered by flashlight batteries
- Portable—weighs only 22 lbs.
- Simple to use

**Adaptable for
Audience
Participation**



The Ampli-Vox Roving Rostrum delivers high quality, high volume sound (voice or music) to audiences as large as 1000! Completely self-contained in a smartly styled Royalite[®] luggage-type case, it weighs only 22 lbs. and works on 10 flashlight batteries that last a year with average use.

For professional quality sound combined with utmost operating simplicity and a surprisingly low price, you'll be delighted with the Ampli-Vox Roving Rostrum. Write today for full information.

The Ampli-Vox Roving Rostrum[®] includes:

- 25 watt transistor amplifier (40 watt peak)
- Microphone and accessories
- 2 full fidelity loudspeakers
- Auxiliary input
- Retractable legs for reading height adjustment
- All in one case—which becomes the lectern.

All for **\$149.95** (less batteries)

Manufactured in U.S.A. by **Perma-Power[®] COMPANY**
AMPLI-VOX / A Division of

5740 North Tripp Avenue, Chicago, Illinois 60646, Area Code 312, 539-7171

Circle 53 on literature card

plifier. Resistor R5 is the output load, across which the clipped audio signal is developed.

The limiter itself cannot remove positive noise pulses that are developed across detector load resistor R3. However, it is characteristic of the AM detector that only one half of the modulation envelope appears in the output. As a result, the diode will not respond at all to positive RF in the secondary of the IF transformer, and demodulated positive noise pulses will not even appear in the diode load.

It is apparent that proper development of the demodulated signal and the efficiency of noise suppression are both related to DC voltages. It is important that the diodes be in good condition. Defects on the AVC line can also reflect unfavorable conditions into the detector and noise clipper circuits.

A less common noise clipper—the shunt type—is shown in Fig. 5. This type of clipper is most effective where incoming signals are usually very weak. It is not self-regulating, and therefore cannot accommodate a wide range of signal levels; however, facilities can be included for switching this limiter out of the circuit when strong signals are received. (When signals are strong, noise is not so objectionable, anyway.)

Summary

Noise-clipping action is invariably related to the strength of the incoming signal. DC voltage changes can have an adverse influence on the operation of the noise limiter, causing either inadequate clipping on weak signals or distortion when strong signals are received. Changes in component values usually cause DC changes which alter the operating characteristics of the noise-reduction circuit. Thus, DC voltage measurements and component checks will often put the finger on deteriorating performance, even before defective operation is audible. ▲

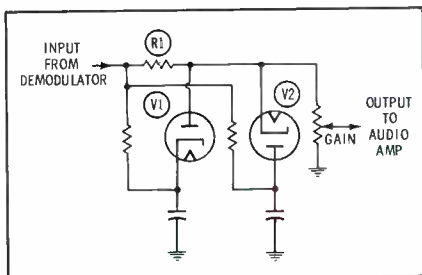

Fig. 5. Dual shunt-diode clipper removes positive and negative pulses.



NEW SECO MODEL 88 TESTS PICTURE TUBES, TOO!

- Tests over 400 cathode ray picture tubes including 110° deflection types for cathode emission
 - cathode emission
 - leaks
 - shorts
 - gas
 - grid emission
- Tests all receiving tubes including novars, nuvistors, 10 pin types, compactrons and magnovals for
 - leaks
 - shorts
 - grid emission
 - gas error
 - filament continuity
 - cathode-to-heater emission

Seco's patented Grid Circuit Test alone makes up to 11 simultaneous checks for tube faults. Tube Merit and Filament Continuity tests increase the test range even more—you locate those "hard to find" faults on your first try.

And now this same tester handles picture tubes, too. Merit test operates at half of rated cathode current—no possibility of damage if filament voltage is correct. Indicates leakage, gas, shorts and grid emission—tapping the tube neck shows up intermittent shorts. Even handles 110° deflection models with universal socket adaptor.

This COMPLETE tester saves you time and trouble—does more jobs quicker and better. New Model 88 comes to you with speed-indexed setup data, pin straighteners and 12-pin picture tube socket on a 3-foot cable. Guaranteed up-to-date—new tube data mailed periodically at no charge to all registered owners.



MODEL 88 - - - \$74.50 NET

Model 88 is also available in a tube caddy. For details see the Seco advertisement on page 79.

For complete information see your distributor or write:



SECO ELECTRONICS, INC.

1221 S. CLOVER DRIVE • MINNEAPOLIS 20, MINNESOTA

A DIVISION OF DI-ACRO CORPORATION

Circle 54 on literature card

BEAU-TECH SOLDERING AIDS

... Twist-proof, chrome-plated tools that make your job easier.



Complete Kit,
Only \$4.87

Here is a complete, quality soldering aid kit of six tools made especially for precision work. The fork ends are ideal for twisting or holding component leads and wires. For removing splattered solder, scraping joints or connections, repairing printed circuits, or reaming out lug holes, just turn the Beau-Tech soldering aid to the spade end. Tools feature insulated, non-slipping, non-rolling hex handles. May be purchased individually. Buy now through your electronics distributor.



Laconia, New Hampshire

Circle 55 on literature card

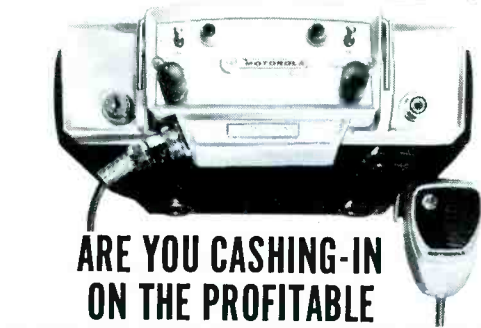

ARE YOU CASHING-IN ON THE PROFITABLE 2-WAY RADIO SERVICE BUSINESS?

- ★ Motorola will train you for this rewarding, elite profession
- ★ Send for our FREE EVALUATION EXAM. Prove to yourself that you are ready to learn FM 2-way radio servicing.

Opportunities in 2-way radio servicing are virtually unlimited. Just one of the hundreds of successful Motorola Service Stations writes, "we would be pleased to interview any graduate of your school that has received some training in 2-way radio maintenance. We are an established firm, 10 years old, with a promise of expansion governed by our ability to obtain competent technicians." Get all the facts today. There is no obligation and no salesman will call.

MOTOROLA TRAINING INSTITUTE

4545 West Augusta Blvd. • Chicago 51, Illinois • Dept. ACX-339

- Send me FREE entrance exam.
- Send full details on Home Study Course on FM 2-way Radio Servicing
- Send me details on how you can help me prepare for an FCC License.

Name _____ Occupation _____
Address _____
City _____ Zone _____ State _____

Circle 56 on literature card

Troubleshooter

(Continued from page 25)

appears; therefore, they cannot account for it.

An erratic defect in the discriminator transformer is a common occurrence in this particular model, and I'd recommend replacing this component as your first move. Printed component combination K7 on the output side of the discriminator is another possible suspect; other components in K6 could be intermittent, and there's even a chance the speaker could be defective.

The grid and cathode voltages on the output tube are definitely on the low side, though apparently not enough to cause real trouble—otherwise, you wouldn't be able to obtain adequate volume at any time. Note that the grid voltage is derived from the main B+ source by the voltage-dividing action of R42 and the 1.5-meg resistor in K6. If the resistance of the former is more than the nominal value, and that of the latter is less than nominal, you will have insufficient grid voltage—even if both resistors are within tolerance. Correcting such an unbalanced condition would allow the output tube to operate with less bias, and would thus make the audio system capable of greater maximum volume.

Two Buzzes

A short time ago I serviced a Sylvania Chassis 548-1 (PHOTOFACT Folder 509-2) that had a slight hum or buzz in the sound, even with the volume control turned all the way down. By disabling the vertical output stage, I could make the buzz disappear; but after checking everything I could think of, including all filters, I couldn't eliminate it.

To make matters worse, a few days later I serviced another Sylvania that had practically the same fault. This one was a Chassis 1-541-3 (PHOTOFACT Folder 427-2). This time, I noticed the buzz could be reduced in volume by about one-half if I removed the antenna. It disappeared completely when I momentarily grounded the plate of the first audio amplifier, but not when I grounded the grid.

Both these sets were being repaired for other troubles, and neither of the owners had complained about the buzz. The receivers are now in use, with no complaints, but it bothered me to leave the buzz uncorrected; I don't like to do a job halfway. This trouble would be a complaint if I were the set owner.

LEE J. WINDLE

Norfolk, Va.

Both sets probably have defects in filter capacitor C2, allowing vertical sweep buzz to be fed into the audio section via the 260-volt B+ line. C2B, the output filter in the power supply, could be doing an incomplete job of filtering; or there could be internal leakage between this section and C2D, the cathode bypass in the vertical output stage. Either of these faults would be hard to detect by ordinary methods, and you would probably have to replace the entire can for an accurate check.

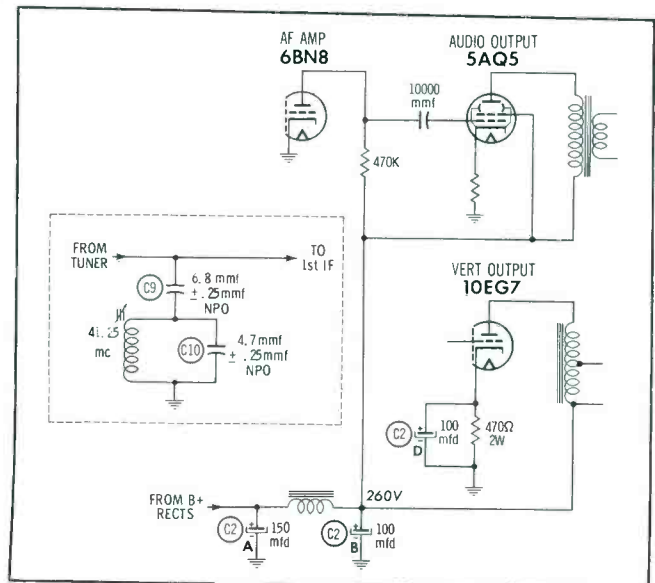

These sets may have double trouble, with sync buzz adding to the vertical sweep buzz. The 548-1 chassis, in particular, has had a characteristic buzz problem traced to the 41.25-mc sound trap in the first video IF stage (see inset in schematic). Two remedies have been suggested by the manufacturer: either adjust the trap slug slightly clockwise from the position of minimum 41.25-mc signal, or interchange C9 with C10 and realign the trap. If these measures don't clear up the sound, further troubleshooting in the front-end, video, AGC, and ratio-detector circuits is advisable.

Transistor Distortion

A Sony Model TR716B transistor radio, in our shop for repair, operates fairly well except for considerable distortion at low volume. We have tried another speaker and checked the radio as best we can, but cannot find the difficulty.

ED KNEPPER, JR.

Wyandotte Radio & Television Service
Kansas City, Mo.

A common cause of such distortion is improper bias on the output transistors. In this particular set, the chief suspects are R23, R24, R25, R26, and the thermistor. Also be sure to check capacitors C25 and C26. If you can find nothing wrong with the output stage, check the components associated with driver transistor X5.

Lazy Vertical

A 21" Midwest TV (similar to Muntz Chassis 49A4A, covered in PHOTOFACT Servicer 587) has trouble in the vertical section. When the receiver is first turned on, it has only a horizontal white line for about two minutes; then the vertical oscillator finally starts, but the raster is still quite nonlinear. The trouble is in the output transformer itself, and I'm having difficulty in locating a replacement. Do you think it would be feasible to change the vertical circuit to a different design?

GALLENTE REPAIR & SALES

Callender, Iowa

Do you have conclusive proof the transformer is bad? Even if you do, I'd advise against completely rebuilding the circuit. The generally critical nature of vertical sweep stages, and the specific problems of replacing the 25L6 in this series-string set with a multisection tube, would make the project unreasonably complicated. In the long run, it would be more expensive than tracking down a replacement transformer.

There's a chance the transformer may not be the problem. Have you noticed the 1500-ohm, 2-watt resistor wired across the filament of the 25L6? Intermittent trouble in this resistor or in the 25L6 filament connections could explain the slow starting of the oscillator; you could detect such a fault by monitoring the AC voltage across the 25L6 filament during warmup. Also make very sure you are not losing B+ to the vertical sweep stage, due to temporary failure of C64B, R76, or one of the components in the vertical size-control circuit. For more ideas on troubleshooting this "all-in-one" stage, see page 7 of the article "Vertical Sweep Troubleshooting From A to Z" in the January, 1962 issue. ▲

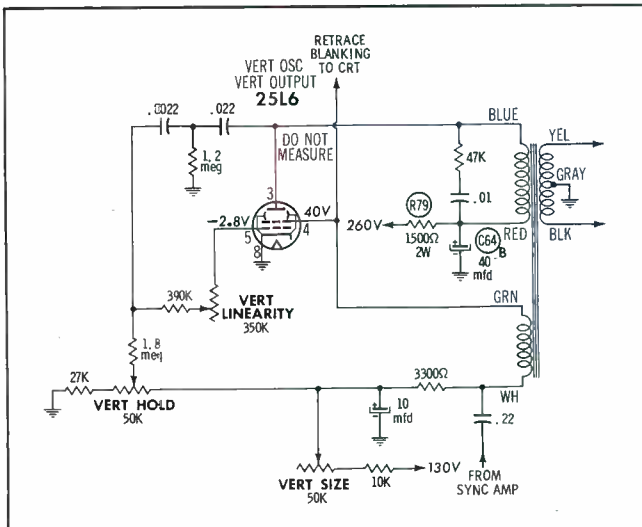

Communications, mobile radio...

A First Class FCC License

...or Your Money Back!

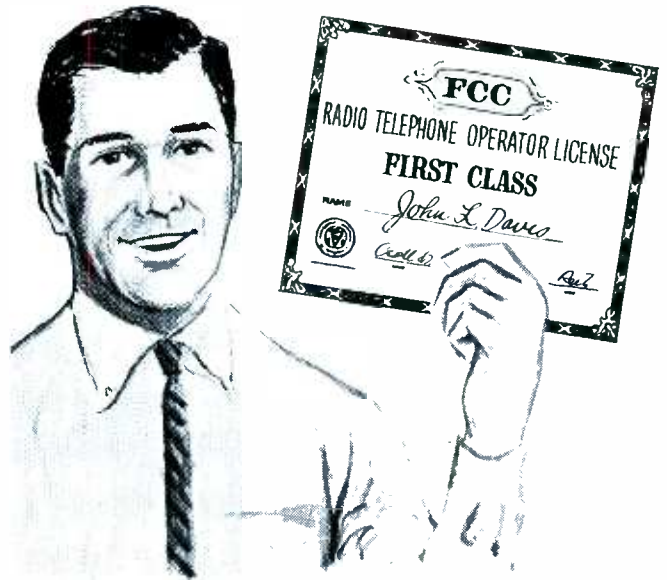

Your key to future success in electronics is a First-Class FCC License. It will permit you to operate and maintain transmitting equipment used in aviation, broadcasting, marine, microwave, mobile communications, or Citizens-Band. Cleveland Institute home study is the ideal way to get your FCC License. Here's why:

Our training programs will quickly prepare you for a First-Class Commercial Radio Telephone License with a Radar Endorsement. Should you fail to pass the FCC examination after completing your course, you will get a full refund of all tuition payments. You get an FCC License... or your money back!

You owe it to yourself, your family, your future to get the complete details on our "proven effective" Cleveland Institute home study. Just send the coupon below TODAY. There's no obligation.

MAIL COUPON TODAY FOR FREE CATALOG

Cleveland Institute of Electronics

1776 E. 17th St., Dept. PF-7
Cleveland 14, Ohio

How to Succeed in Electronics

Please send FREE Career Information prepared to help me get ahead in Electronics, without further obligation.

CHECK AREA OF MOST INTEREST -

- | | |
|---|--|
| <input type="checkbox"/> Electronics Technology | <input type="checkbox"/> First-Class FCC License |
| <input type="checkbox"/> Industrial Electronics | <input type="checkbox"/> Electronic Communications |
| <input type="checkbox"/> Broadcast Engineering | <input type="checkbox"/> _____ other _____ |

Your present occupation _____

Name _____ (please print) Age _____

Address _____

City _____ Zone _____ State _____

Accredited Member National Home Study Council

Vertical Creep

(Continued from page 39)

we've already described to help you corner the culprit, there are some short cuts that experienced servicemen use to pinpoint certain common troubles and solve them quickly. Here are some typical faults with "easy" solutions.

Top Stretched

This symptom is generally accompanied by a severe compression of lines at the bottom of the raster, making it appear as if a white line borders the picture. In many in-

stances, foldover occurs along the bottom.

This fault is usually caused by a decrease in bias on the output tube. In normal operation, the output stage is biased so the drive signal never makes the grid more positive than the cathode. When bias is insufficient, two things happen: The early portion of the sweep (near the top of the picture tube) is over-amplified because of suddenly increased gain in the output tube. The later portion of the vertical sweep, however, doesn't fare so well; when the grid is driven posi-

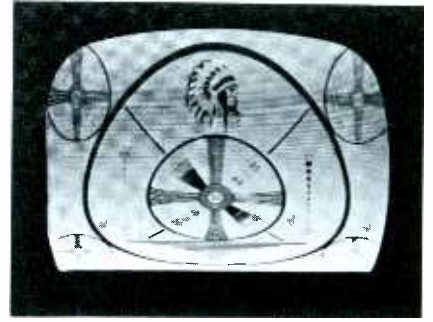

Fig. 4. A common type of vertical creep: top stretched, bottom cramped.

tive, the tube saturates and can't amplify at all—with the result shown in Fig. 4.

The causes? There are two very common ones, each with its own peculiarities. The more common of the two will frequently cure itself after the set warms up for awhile. A special clue is that the effect is worse after the set has been idle for some time, like during vacation. The culprit in this case is nearly always the electrolytic cathode-bypass capacitor in the output stage. What happens is that the unit deforms during periods when no polarizing voltage is applied, then heals itself—at least temporarily—when the set is turned on again.

The same component can perform just the reverse, too. It can develop leakage after the set has been on for awhile, lowering the bias and causing the stretch and foldover mentioned. Whenever cathode voltage on the output tube changes drastically as the set warms up, suspect this troublesome capacitor first, and then the cathode resistor.

The second cause for decreased bias—and this one is rather common, too—is leakage in the large tubular capacitor that couples the vertical drive signal from the oscillator to the grid of the output tube. Leakage here causes a positive shift of grid voltage. As pointed out before, this is not always easy to measure with a VTVM; furthermore, the more positive grid voltage may cause an increase in cathode current—thus masking any clue you might find by measuring bias between cathode and grid. When the "stretched top" symptom appears, and cathode voltage seems normal or slightly high, try disconnecting the grid end of the coupling capacitor and checking with your VTVM for a positive reading; you may even have to temporarily dis-

INSTALL and SERVICE COLOR TV in the HOME



**FAST-SIMPLE
COLOR and
Black & White
SERVICING**

ONLY

6950

TEST PATTERN GENERATOR



Designed for low cost color servicing . . . on location! Light-weight, compact, GC's new Color Test Pattern Generator eliminates lugging heavy, bulky equipment into the customer's home—allows Color set-up, final convergence and purity checks to be made quickly, easily . . . economically!

Simple to operate . . . easily connected, the generator produces 3 different patterns, each with a specific function, including individual switching for any combination of three color guns . . . for fast purity or convergence checks without upsetting color controls.

PLUS . . . many more features! Complete specifications are available from your GC distributor or by writing GC.

**No. 36-610-A Complete in rugged,
handsome carrying case . . . Net \$69.50**

GC ELECTRONICS CO.

DIVISION OF TEXTRON ELECTRONICS, INC., 400 S. WYMAN STREET, ROCKFORD, ILLINOIS, USA

Circle 58 on literature card

GENERATES THESE PATTERNS



DOTS

HORIZONTAL
BARS

VERTICAL
BARS

Write for the all new GC 340 page Master catalog . . . with the complete Test Equipment line and over 12,000 other products.



able the oscillator to get a conclusive measurement.

Bottom Stretched

This symptom is caused (as you may suspect) by exactly the opposite trouble from that just mentioned; with this symptom, you can almost always expect an increase in bias. "Bottom stretch" is often, but not always, accompanied by compression at the top of the raster, denoting that the tube is nearly cut off during the first part of its conduction cycle.

Fig. 3B pointed out one classic example of this fault, where the cathode resistor had increased in value. Of course, the control itself could become defective (and often does), changing value with heat. This is particularly common with certain printed-type controls.

In other types of circuits, the fault may be from some other source. If there's a grid-circuit linearity control to govern the negative voltage picked off from some fixed source, it's possible the resistor that grounds one end of the control is rising in value with heat.

However, if you run into the type of circuit that takes the negative linearity-control voltage from the hold-control circuit, don't worry too much about this network being a cause of linearity trouble; any fault will usually affect the vertical-oscillator frequency long before it seriously affects linearity.

Shrinking

Lastly, there's that elusive fault that causes the raster to creep up from the bottom *and* down from the top, with little apparent change in linearity. And, lo and behold, the voltages and waveforms in the output stage look good. What now?

This trouble is less common than those mentioned earlier, but is equally important to understand, for there are several possible sources of trouble. In all cases of vertical creep, it is wise to start by replacing the vertical sweep tube (or tubes), which most technicians do anyway. But here's a symptom where it pays to try another output tube; some just don't have what it takes for certain circuits.

Next, check the supply voltages, especially in those cases where the vertical stages take power from the

SARKES TARZIAN Silicon Rectifiers

are first choice among service technicians (according to a nation-wide poll) for the third year in a row



Tarzian 400V and 600V "F" Series units in handy Ten-Paks, Doubler Replacement Kits, and in bulk



Tarzian 400V and 600V "H" Series units in handy Ten-Paks, Doubler Replacement Kits, and in bulk

Preference high! Here's why:

- ★ They are immediately available from distributors throughout the nation
- ★ They are "handy-packed" in the quantities and sizes you need most
- ★ Their proven quality and dependability eliminates callbacks that waste your time and profits

A free Tarzian "Replacement Line" catalog is yours for the asking. It's your guide to replacement rectifiers with competitive prices, unsurpassed performance.

Write or call your nearest Tarzian distributor, or:



Tarzian's nine standard tube replacement rectifiers replace over 95% of all vacuum tube rectifiers



Tarzian M-500 and M-150 units in Conversion Kits and in bulk



Tarzian's four "condensed stack" selenium rectifiers fit small-size, high-efficiency applications



SARKES TARZIAN, Inc.

World's Leading Manufacturers of TV and FM Tuners • Closed Circuit TV Systems • Broadcast Equipment • Air Trimmers • FM Radios • Magnetic Recording Tape • Semiconductor Devices
SEMICONDUCTOR DIVISION • BLOOMINGTON, INDIANA
Canadian Licensee: Marland Engineering Limited • 350 Weber Street North, Waterloo, Ontario

Circle 59 on literature card



For best results
squeeze bulb
from sides
rather than up
against handle

ENDECO DESOLDERING IRON

removes soldered connections
quickly . . . easily . . . profitably

No need to send your printed circuit boards out to a specialist when you have an Endeco Desoldering Iron. You'll find it easy to remove transistors, transformers, condensers, resistors, diodes and even those difficult multiple pin or button type sockets with center posts. Endeco puts the profit margin back into your printed circuit work.

Any iron will melt solder; Endeco with its vacuum pickup completely removes melted solder . . . collects it in a non-breakable, stainless steel tube. The exclusive compact design lets you see the connection while you're desoldering. One hand operation.

No need to reach for another tool. Without even changing tips, you can resolder a clean, new connection. Worn tips are easily replaced, when it is necessary, even while iron is hot.

Endeco Desoldering Iron is not an attachment, but a complete desoldering/resoldering tool. The desoldering principle (pat. pending) is incorporated into the rugged Weller soldering iron with the exclusive Weller Magnastat sensing device in tip body which maintains constant temperature.

The new Model 100A Endeco Desoldering Iron is available at your electronic distributor or write direct.



ENTERPRISE
DEVELOPMENT
CORPORATION

1102 East 52nd Street
Indianapolis 3, Indiana 46205
Circle 60 on literature card

boost source; you might have a horizontal trouble contributing to your vertical problem. Check any decoupling resistors or capacitors for a possible shift in value. (The resistor will affect supply voltage, while an open capacitor will contribute degeneration and thus reduce signal amplitude.) If the set uses a pentode tube, be sure to check the screen-circuit components.

It's As Easy As That

That covers the most likely faults, but not quite all the possibilities. There are still the transformer and yoke. We've saved them for last, because they are the least likely of any component to develop the peculiar symptoms associated with vertical creep. When coils go bad, they usually just go bad and that's it.

Generally speaking, you will have to check the yoke and output transformer by substitution; any defect that would cause creep would be next to impossible to measure with service-type instruments.

However, don't forget there are a couple of resistors in most yokes; these may shift value enough to cause trouble. In modern 110° yokes, a thermistor is generally used to counteract any natural tendency of the vertical output system to "creep." Check it; be sure it is changing value with temperature as it is supposed to.

So you see, vertical creep is nothing to fear; it is merely something for which you should be constantly alert, because you may run into it at anytime. And if you attack it with common sense and understanding, you'll join the ranks of technicians who no longer lose money to this sneaky offender.

"S" for Sensitivity

Often it is desirable to measure the relative signal strength being received by a radio—especially in one used for communications. Some receivers include such a meter, but many do not. For these latter sets, Seco Electronics has devised the Model 540 "S" Meter shown in the photo. This unit can be added to almost any type of existing receiver, including Citizens-band sets, communication receivers, and even tele-



vision chassis.

The Model 540 is designed to connect to most AM sets in series with the diode load. The instrument is actuated by the change in diode load current as signal strength varies. Although this change is much too small to be read on an ordinary milliammeter, the 540 utilizes a transistor to amplify this slight DC shift enough to actuate an inexpensive 1 ma, 1000 ohm meter movement. The transistor is powered by a 9 volt battery within the unit.

In FM communications receivers, the demodulator doesn't usually include a convenient source of DC current that changes with signal strength. However, the limiter stage draws grid current that is proportional to signal level. Even though this grid current is only a few microamperes, the sensitivity of the transistorized metering circuit in the 540 permits using even this slight indication.

The "S" meter can be connected to any receiver by only two wires, enclosed in a shield. The unit also includes, however, a twisted pair that connects to a dial lamp for lighting the scale meter, if desired. The dial lamp can be powered from the heater string of a tube-type receiver, or directly from the power input of a transistorized unit that is powered from a vehicle battery. The current drain of the lamp would discharge a small dry cell in a hurry, however.

When connected to a suitable receiver, the unit can be used to evaluate reception conditions, or as a field-strength meter for making transmitter adjustments. In the latter use, be sure the signal reaching the receiver is barely sufficient to cause a reading below "S9" on the meter. ▲

For further information, Circle 80 on literature card.

Old TV

(Continued from page 37)

bandwidth in this chassis is very close to 4 mc.) The immediate complaint was rapid vertical rolling that began soon after warmup. The customer had tolerated it as long as it could be stopped with the hold control, but by now the vertical oscillator seemed to be drifting far out of range.

An inventory of other symptoms turned up the following: The picture tube, the *original* metal 17GP4, was slow to warm up, but the customer was in the habit of turning the set on 10 minutes before a program. An intermittent "whiteout" of the picture occurred only on channel 13, which the customer said he seldom watched anyway. Finally, the horizontal oscillator had a slight tendency toward intermittent squegging.

New tubes in the vertical sweep and sync stages did not stop the rolling, so the customer okayed shop service. At the bench, the serviceman found the chassis exceptionally clean. The only previous repairs of any consequence were in the tuner, video output, and sync stages. The rolling was quickly subdued by replacing two capacitors in the feedback network of the vertical multivibrator. Proper horizontal-waveform adjustment cured the Christmas-tree effect, as anticipated. The channel-13 trouble was left until after further tests were made in the chassis.

The general performance checks (Fig. 1) revealed only a few discrepancies. All power-supply voltages were slightly high because the selenium rectifiers in the full-wave doubler B+ supply had been replaced with silicons. To ward off future problems that might be caused by too much B+ voltage, a 10-ohm, 10-watt dropping resistor was added in series with the input to the rectifiers.

In the vertical sync section, no definite cause could be found for the slightly low amplitude of the output signal; since this was not causing trouble, no further efforts were made to correct it. The AGC circuit and tuner were spot-checked for obvious faults that might explain the dropout of channel 13, but nothing was discovered.

The serviceman decided to "cook" the set before proceeding. With the chassis inside the cabinet,

MEASURE AC VOLTAGES .0002 VOLT to 500 VOLTS

New RCA WV-76A
High-Sensitivity
AC \sqrt{V} M

A combination voltmeter-and-preamplifier designed for audio applications in industry, laboratories, schools, broadcast studios, research and development work, production-line testing and general electronic servicing. Use to test frequency response of preamplifiers, power amplifiers and tone control circuits; for signal tracing, audio-level and power-level measurements; gain measurements, amplifier balancing applications and audio voltage measurements.



Nine overlapping AC voltage ranges — from 10 mv to 100 v full scale. On 10-mv range accurate readings can be made to as little as 0.2 mv. With input probe set in "low-cap" position, up to 500 ω may be measured.

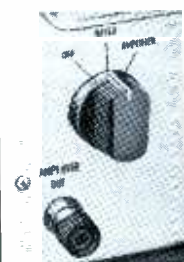

Use either as a meter or preamplifier: 38 db maximum gain on 10 mv range

- Flat frequency response ± 1 db from 10 cps to 1.5 Mc with "direct" probe—10 cps to 500 kc with "low-cap" probe.
- Measures decibels from -40 to +40 db in 9 overlapping ranges (Up to 56 db with probe switch in "low-cap" position.)
- High input impedance permits accurate measurements in circuits sensitive to loading.
- Probe and cable fully shielded to eliminate stray pickup.
- Large power-supply filter minimizes hum.
- Feedback loop from metering circuit provides additional stability and linearity.
- Compact, lightweight, portable: 7½ inches high, 5 pounds.

Factory wired and calibrated: \$79.95*

Money-saving kit WV-76A(K): \$57.95*

See it at your Authorized RCA Test Equipment Distributor.
*User price (optional)

RCA ELECTRONIC COMPONENTS AND DEVICES, HARRISON, N. J.



THE MOST TRUSTED NAME
IN ELECTRONICS

Circle 62 on literature card

SOLVE!

90%

OF YOUR PROBLEMS
IN CONNECTING TWO
PIECES OF EQUIPMENT
THAT DO NOT HAVE
MATCHING CONNECT-
ORS WITH

THE NEW ADAPTER KIT



Kit No. 331A
Dealer Net Only
\$9.00

Contains 11 popular audio adapters and 1 "universal" interconnecting cord—all in a handy reusable plastic box. Applicable for hundreds of various connections, such as —

- Two "Y" connectors let you drive both channels of a stereo amplifier with one signal generator — also, feed two inputs into one phone jack.
- Connect coaxial test leads directly to input or output jack of equipment (such as TV Remote Controls) — No clip-lead Hook-Ups.
- Save time, eliminate "make-shift" connectors, avoid soldering. Always a neat job with Switchcraft Adapters. When a special connector is needed — just slip on an adapter from your Kit.
- Also a handy - profitable way to stock adapters for your customers every need. The 331A Adapter Kit is now in stock at your distributors. Write for Bulletin No. 112.

SWITCHCRAFT

5573 N. ELSTON AVE. CHICAGO 30, ILL.
Circle 63 on literature card

92 PF REPORTER/October, 1963

a slight tendency to vertical rolling appeared after more than an hour of operation, but barely touching up the hold-control setting restored stable sync.

After a considerable period of operation, the set suddenly developed all the symptoms of AGC failure; so, back on the bench it went. The grid voltage of the AGC keying tube (Fig. 2) was far below normal. Tracing the grid circuit, the serviceman found low voltage also on the cathode of the horizontal-sync separator. The cathode-bypass capacitor was running hot, and turned out to be shorted. After replacing it, the serviceman phoned the customer, who asked to have the set delivered without further attempts to straighten out the minor kinks in its operation.

He was happy with the improvements that had been made, and felt he had obtained his money's worth from the bench repairs — even though a burned-out flyback and focus circuit compelled the junking of the set within a year. He's just glad he didn't decide to go ahead and have the CRT replaced!

Arvin Chassis TE332-4

This 1954 table model had been regularly used by a family until 1960, when picture troubles developed. They bought a larger-screen set at that time, but also had the old set repaired. The serviceman located a burned-out resistor in the cascode RF circuit, and restored the picture by replacing this resistor and a 6BZ7 tube. The Arvin was used as a second set for two years; then the same symptoms reappeared. Since a repetition of the tuner trouble was suspected, shop work was agreed on. Checking voltages to the tuner, the serviceman found only 15 volts on the low B+ line. R128 (Fig. 3) had increased to more than 100K. Filter capacitor C2 had been leaking electrolyte, so it and the resistor were both replaced. As soon as power was applied, the plate resis-

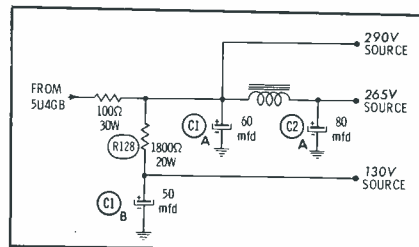

Fig. 3. Loss of picture and sound was traced to trouble on low B+ line.

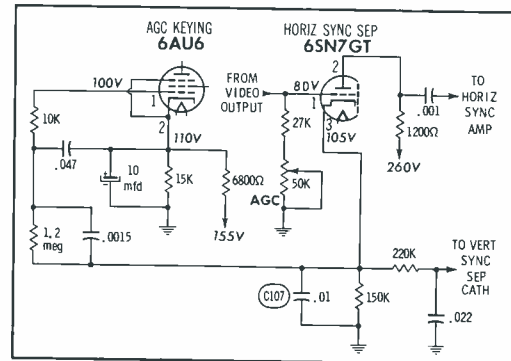

Fig. 2. Bypass capacitor shorted while set was being "cooked" after repair.

tor of the second video IF stage went up in smoke. The tube in this stage was found to be shorted. After the necessary repairs were completed, the picture and sound came back.

Amazingly, the CRT in this set (another original!) still presented a reasonably good picture after a 5-minute warmup. The under-chassis circuits were also in excellent physical shape; except for the tuner, they had never been worked on before. However, a quick run through the list of key check points (Fig. 4) uncovered several minor faults.

NEW!

ARROW'S T-18 Low Voltage Wire STAPLE GUN

For Fastening Any
Inside or Outside
Wire Up to 3/16" in Diameter

Takes a 3/8" leg staple with 3/16" crown.

- Telephone wire
- Intercom wire
- Bell wire
- Thermostat wire
- Radiant heating wire
- Hi-Fi, Radio & TV wires

Tapered striking edge gets into close corners!

Steel wire staples available in brown, ivory, beige or natural; bronze and monel staples also available.

ARROW FASTENER CO., INC.
ONE JUNIUS STREET • BROOKLYN 12, N. Y.

Circle 64 on literature card

CHASSIS ARVIN TE 332-4		SERVICE ORDER NO. 87770
TEST	NORMAL	ACTUAL
B- DC	265V	260V
B- RIPPLE	.3V P-P	.7V P-P
LOW B- DC	130V	138V
LOW B- RIPPLE	NOT SPEC	.1V P-P
BOOST	560V	480V
✓ HORIZ DRIVE	100V P-P	80V P-P
HORIZ OUTPUT SCREEN DC	145V	140V
HORIZ OUTPUT CATH CURRENT	100 ma	110 ma
✓ VERT DRIVE FOR NORMAL HEIGHT	100V P-P	75V P-P
VIDEO FROM DET	4V P-P	3V (LOC) 5V (DIST)
VIDEO TO CRT	50V P-P MINIMUM	50V P-P UNDISTORTED
OBSERVATIONS		
SYNC OUTPUT	20V P-P, NO VIDEO CONTAMINATION OR INSTABILITY, SOLID LOCK.	
ACC DC	PROPORTIONAL TO RF INPUT	
ACC RIPPLE	.3V P-P HORIZ SPIKE	
HORIZ SWEEP ADJS	AFTER CONFIRMING MULT OK, RESET DRIVE FOR 100V P-P	
✓ VERT LIN AND HEIGHT ADJS	LIN AT END OF RANGE, STILL SLIGHT DISTORTION	
HIGH VOLTAGE	OK, NO ARCING OR BLEEDING	
✓ SOUND	LOUD POP ON WARMUP OR WHEN B- IS PROBED	
✓ TUNER	NO SNOW, DCC ADJS OK, CH 13 MISSING	

Fig. 4. Results of general performance tests on another old TV receiver.

The slightly weak horizontal drive signal was evidently a simple matter of a misadjusted drive control, but the horizontal multivibrator was checked just as a precaution. The lock-in point on the hold control was suspiciously close to one end of its range. The cause was simple: The common cathode resistor of the multivibrator had increased from 1200 to 1350 ohms, throwing the circuit off frequency.

The abnormal vertical drive signal led to the discovery of a small positive voltage on the grid of the vertical output tube—eliminated by replacing a leaky grid-coupling capacitor. This repair also improved the vertical linearity.

Another leaky grid capacitor was found in the audio output stage, where the grid measured +35 volts. Replacing this capacitor eliminated the "pop" in the sound.

The channel-13 trouble in this set, unlike that in the RCA, was easy to remedy. There was merely a sprung contact on the oscillator switch wafer, spotted by close physical inspection.

No more troubles emerged during the shakedown period; in fact, this stout old set is still running. A pleased owner will tell you it was definitely worth repairing. ▲

now In Stock At Your Local Distributor

FLYBACK TRANSFORMERS

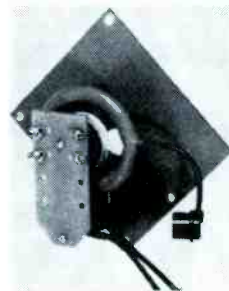

Merit	Manufacturer	Part #
HVO-221	Philco	32-8951-4
HVO-222	Motorola	24K736487
HVO-223	Motorola	24D65410A2/-B/-1
HVO-225	Setchell Carlson	TWF-110/X,WF-90

VERTICAL OUTPUTS



Merit	Manufacturer	Part #
A-4111	Magnavox	320255/-1-2/-3/-4
A-4113	Magnavox	320079-1/-3/-4
A-4117	Muntz	TO-0056
A-4119	Olympic	TR-25791/-1A/-C/-2

AUTO RADIO IF TRANSFORMERS

Merit	Manufacturer	Part #
BC-684	Ford	2090237-2
BC-685	Ford (Bendix)	2090237-3
BC-686	Mercury (Bendix)	2090237-4
BC-687	Ford	2090239-1
BC-688	Ford (Bendix)	2090239-2
BC-689	Mercury (Bendix)	2090239-3
BC-690	Automatic (Riverside)	14-270/A/X
BC-691	Automatic (Riverside)	12-271/A/X



FILTER CHOKE

Merit	Manufacturer	Part #
C-4115	Wells Gardner	52X95-2/-3/-4 etc.

MERIT PLAZA - HOLLYWOOD, FLORIDA

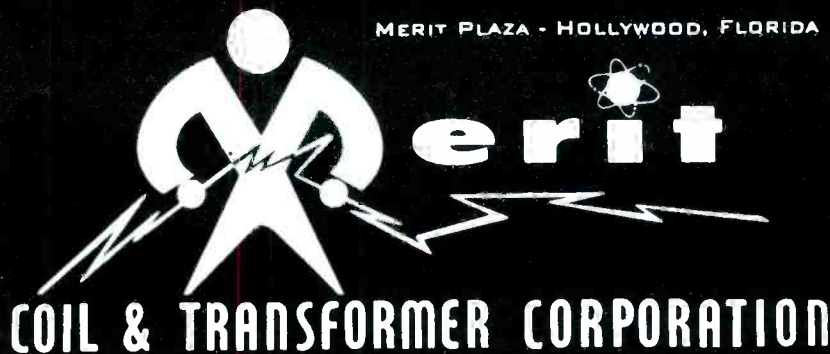

Circle 65 on literature card

NEW SAMS BOOKS

Basic Electronics Series: TV Sync and Deflection Circuits

by Capt. T. M. Adams, U.S.N. Latest volume in the series, utilizing a dynamic new method to explain circuit actions—unique 4-color diagrams show you what takes place during every moment of circuit operation. Explains automatic gain control, sync separation, noise limiting, horizontal-frequency generation, control. 5½" x 8½". BEV-1, only... \$2.95

Basic Electronics: Radio Circuits. BER-1, \$2.95

Basic Electronics Series: 4 Volumes in slipcase—Amplifier Circuits, Detectors & Rectifiers, Oscillator Circuits, Transistor Circuits. Order BEL-40, only \$9.95

Phonograph Cartridge & Needle Replacement Guide
by the Howard W. Sams Technical Staff. Most comprehensive guide available to replacement cartridges and needles. Listed by original parts numbers and by equipment manufacturers' model and part numbers. Fully cross-referenced. 96 pages, 5½" x 8½". Order RCN-1, only... \$1.95

Handbook of Transistor Circuits

by Allan Lytel. Presents valuable information on the design, operation, and application of more than 200 practical transistorized circuits for use in counters, power controls, timers, indicators, photoelectric devices, power regulators, amplifiers, power supplies, oscillators, power converters, etc. Includes schematics, parts lists, and descriptions of operation for \$4.95 each circuit. 224 pages, 5½" x 8½". TCL-1, only.

TV Home-Call Service Guide

by the Howard W. Sams Engineering Staff. A complete guide for use on home service calls. Covers over 250 TV models produced in 1963. Shows tube types and locations, fuse values, location of controls, tube trouble symptom checks, service adjustments, other valuable home-call data. 192 pages, 5½" x 8½". Order GTV-1, only... \$3.95

Electronics Math Simplified—2 Volumes

by Alan Andrews. These two volumes are specifically written to provide a knowledge and clear understanding of mathematics as it applies to electronics. Vol. 1 covers basic algebra, logarithms, trigonometry and specific applications of math to electronics practice. Vol. 2 includes advanced sections on algebra, trigonometry; circuits and component data calculations, Boolean algebra, and mechanics. An excellent self-study guide. 2 volumes in slipcase. MAT-20, only... \$7.95

Understanding and Using the Slide Rule

Gives you an easy basic understanding of how the slide rule operates and how to use it properly for multiplication, division and reciprocals, combined operations, and squares and square roots. Explains all parts of the rule, terms used in operation, methods for obtaining correct answers. 96 pages, 5½" x 8½". Order SRT-1, only... \$1.95

Magnetic Recording for the Hobbyist

by Arthur Zuckerman. A handy, informative guide for everyone interested in tape recording. Covers: Taping Broadcasts & Recordings; Tape & Hi-Fi Component Systems; Commercially Recorded Tapes; Taping Live Sound; Special Effects; Taping for the Record & Correspondence; Recording in the Field; The Party Recorder; Editing & Producing Tape; Making Movie and Slide-Show Sound Tracks; Sound Effects; Ribbons of Sound. 128 pages, 5½" x 8½". Order MRZ-1, only... \$2.50

ABC's of Television Servicing

by the Howard W. Sams Editorial Staff. An excellent introduction to TV servicing. Explains functions of each stage of a TV receiver, waveforms encountered at various points, types of test probes used in trouble-shooting. Shows how test patterns (both station and generator) can be used to isolate trouble. Special chart shows most common causes of trouble symptoms encountered in both black-and-white and color sets. Gives handy constants and formulas required for TV servicing; includes color codes and valuable information on components. 96 pages, 5½" x 8½". Order STA-1, only... \$1.95

HOWARD W. SAMS & CO., INC.

Order from your Sams Distributor today, or mail to Howard W. Sams & Co., Inc., Dept. K-33, 4300 W. 62nd Street, Indianapolis 6, Ind.

Send me the following books:

- BEV-1 BEL-40 TCL-1 MAT-20 MRZ-1
 BER-1 RCN-1 GTV-1 SRT-1 STA-1

\$ _____ enclosed. Send FREE Booklist

Name _____

Address _____

City _____ Zone _____ State _____

IN CANADA: A. C. Simmonds & Sons, Ltd., Toronto 7

Circle 66 on literature card

Twisters

(Continued from page 35)

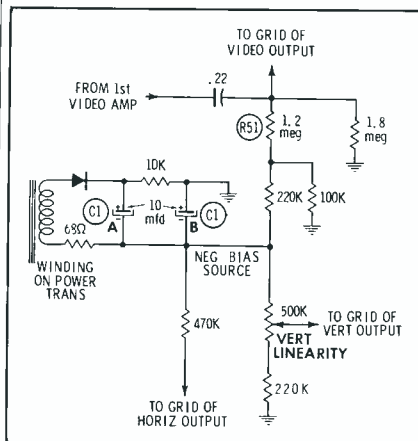

Fig. 6. Ripple in fixed negative bias voltage affected several key stages.

is seen, it will usually be remembered.

When such a twist is constantly present, the easiest way to locate its cause is to scope various filters throughout the set. A signal similar to Fig. 4C will be found on every section of the improperly grounded capacitor. But if the condition occurs intermittently, it requires an altogether different troubleshooting approach. The service technician can apply pressure to each of the filters—either pulling or pushing—while scoping a section of the can being manipulated. If there is a bad ground on that can, it will be made obvious by the abnormal signal on the scope.

More About Hum Bars

Slight amounts of picture shading that accompany some twist symptoms may be hard to recognize, because the intensity of the

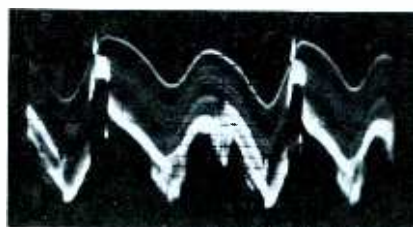

Fig. 7. Video distortion caused severe picture shading, but very little twist.

DIG OUR CRAZY SALES HELPS

There's a whale of a lot of sales assistance for the A/S customer, says Bob Beebe, Antenna Specialists, Director of Sales.



First Folks . . . a quickie about quality design and construction of our antennas — like materials that cost us more but not you. Result: Easiest installations and fewer service problems than any brand going — honest!

Now . . . let's talk up a small storm starting with an important thought on pricing policy. With us, you order only what you want and need, all at the best price possible. Overloading is bad business for both of us. Right?

And speaking of orders — here's something no one else in the industry has . . . a whole bank of automatic order handling equipment that boils down the processing of your orders to just three days! (It took a bank to buy it too, but the world's fastest service means more profit to you as well as A/S!)



Holy Mackerel! Do we get the requests from CB clubs, hamventions and dealers for field assistance! Nobody — but nobody — travels as far to help you as much as our A/S field men.

Do we pre-sell your customers? You can't pick up a CB or amateur magazine without seeing one of our powerful ads — including the big electronic mags too. Like more than 5,300,000 messages a year to the novice and "pro."

Just can't help doodlin' with our famous display stand — only 2 sq. ft. of space, but it sells antennas and accessories like crazy. Yep — we've got loads of the most useful literature tool! Like our five-section catalog — we had to put it in sections 'cuz there's over 400 models to choose from! Most complete line of communication antennas — by a country mile — all bands. You buy from one source and man, how that saves you trouble and expense!

I'm running out of space but you get the idea. We at Antenna Specialists are all out to help you sell, sell, and sell. We're one big happy family, out for a "picnic of profits." Won't you join us? Thanx!

the antenna specialists co.

Antenna Division

"Stripes of Quality" 12435 Euclid Ave., Cleveland 6, Ohio
Exp. Div.,
64-14 Woodside Ave., Woodside 77, N.Y.

Amateur, professional and CB antennas. ZEUS portable generators. ANZAC test instruments.

Circle 67 on literature card

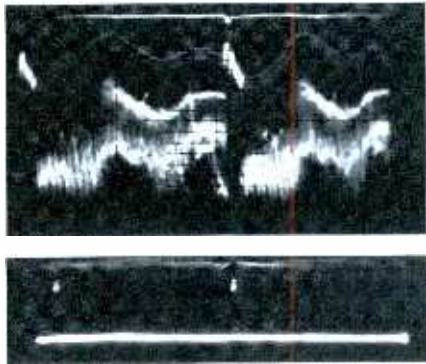

Fig. 8. Input and output of sync separator explain why twist was slight.

shading is affected by the setting of the brightness control. At relatively high brightness, shaded areas or bars become virtually unnoticeable; but at low brightness, some shading will be noted even in normally operating receivers. Therefore, unless hum bars and similar symptoms are quite pronounced, they are often of limited value in diagnosing the cause of a twisted picture.

A more reliable way to determine whether a twist-producing defect is present in the video output signal is by scoping that signal. Referring again to Fig. 3C, note that the shading as well as the twisting in the picture bears a relationship to the curvature in the scope trace.

A Misleading Circuit

Some receivers have unusual circuits that can cause apparently contradictory symptoms when faults develop. Take the 1952 Philco that produced the twist shown in Fig. 5A. Although there was no visible shading to coincide with the twist, there was a slight vertical jitter that



Fig. 9. Billowed raster was obviously a result of 60-cps hum in the video.

make extra dollars with your scope

An oscilloscope gives a visual picture of what is happening in a circuit, something no other test instrument can do. This very feature makes a good scope a money maker for your shop. It saves you time, analyzes those intermittent faults, and makes routine servicing easier than ever. Once you start using a scope regularly you'll never be without one.

You've pulled a set with a buzz in the sound. Is it 60-cycle hum or 60-cycle buzz? A quick look with the scope and you'll know. You'll either see a 60-cycle sinewave caused by heater-cathode leakage or there'll be a vertical deflection sawtooth probably resulting from a defective bypass capacitor.

If alignment required? A scope is a must. Set it up along with your EICO post injection sweep generator, and you have only to adjust transformer and sound trap slugs to finish the job. Same thing for setting up the 4.5-mc sound takeoff network.

Losing the signal somewhere in the video circuits? Hook up the scope and see where it's going astray. There's a good chance you'll spot the bad component at the same time.

But when you go to buy a scope, what do you look for? Large screen, high sensitivity, frequency response, attenuators, synchronization, calibrator? All of these are important and are included in the design of any professional scope intended for the service technician.

Large screen: You can get by with 3 inches, but take the 5-inch screen of the EICO 460. Get a close look at what's happening. It's got an edge lit calibrated bezel too. **High sensitivity:** The 460's vertical amplifier delivers 25 mv per cm. All you'll ever need and more. **Frequency response:** EICO makes it flat from dc to 4.5 mc

in the 460. Ideal for color and black and white as well as industrial production and research, audio testing and experimenting. **Attenuators:** The vertical attenuator in the EICO 460 is a 4-step frequency compensated network. Can't beat this kind of design. **Sync:** Any signal reaching the screen is fully synced — automatically. And for special purposes you can inject your own external sync signal. **Calibration:** Accurate peak-to-peak voltage calibrator is built right into the 460.

All this adds up to the top scope for TV service. You can get it as a kit for \$89.95 or completely wired for \$129.50.

If you don't need so elaborate an instrument, take a careful look at the 427 dc to 1 mc scope or the new 3" General Purpose scope, the EICO 430 (kit, \$65.95; wired, \$99.95). The new 430 does everything bigger and more expensive scopes do. Vert amp/flat from 2 c to 500 kc, —6 db at 1 mc. Sensitivity 25 mv/cm. Horiz amp. flat from 2 c to 300 kc. Sensitivity .25 V/cm. Flat face 3" tube; mu-metal shield eliminates effects of external fields.

There are plenty of accessories for EICO scopes too. An Electronic Switch to put two different signals on the scope screen at the same time (EICO 488; kit, \$23.95; wired, \$39.95). Voltage Calibrator for the less expensive 427 and 430 (EICO 495; kit, \$12.95; wired, \$17.95). Three accessory probes-demodulator, direct and low capacitance types.

Whether it's scopes, tube testers or VTVM's you get the best for less with EICO. Save money by building your instruments from kits, or buy them factory-wired at a substantial savings. See your distributor. Write for complete 28 page catalog. Dept. PF-10 Add 5% in west



EICO ELECTRONIC INSTRUMENT CO. INC., 3300 Northern Blvd, L. I. C. 1, N. Y.

EXPORT: ROBURN AGENCIES INC., 431 GREENWICH ST., N. Y. 13, N. Y.

Circle 68 on literature card

suggested a sync defect, and I found a hum-like distortion of the video signal at the plate of the 6AQ5 video output tube (Fig. 5B).

The defect was finally discovered to be nothing more than a poorly grounded filter capacitor C1 in the special rectifier circuit shown in Fig. 6. Since this circuit feeds negative voltage to several different stages as fixed bias, excessive ripple due to the fault in C1 caused a variety of symptoms. The grids of both the video output and the vertical output tube were modulated by the unwanted signal, accounting for the distorted video waveform and the vertical jitter. The ripple was also applied to the grid of the horizontal output tube, producing a more severe twist in the raster than would have happened if the distortion had been confined to the video and sync signals.

Several different approaches could have been taken to solve this unusual problem; the method I chose was that of following up on the suspicious curvature I had noted in the plate signal of the video output stage. The same distortion was also present in the grid waveform.

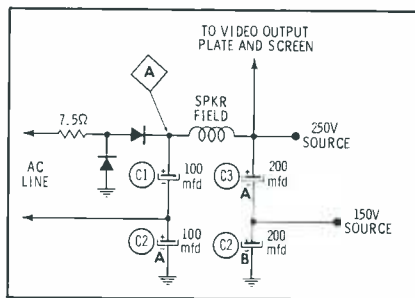

Fig. 10. How could this full-wave voltage doubler produce 60-cps ripple?

Suspecting a tube defect, I pulled both tubes in the video amplifier section—only to find a 60-cps hum waveform still remaining on the output grid connection. I traced back through R51 to find the source of the hum, and was eventually led to the bias rectifier and its bad filter.

Slight Twist; Heavy Shading

In the picture on an Emerson 120182-D (Fig. 7A), twist was only a secondary clue; the only fault the customer found objectionable was the considerable shading of background brightness. The defect was found in as little time as it takes to check several filter capacitors with the scope. The third prob-

ing, at the filter on the B+ branch feeding the IF's, incriminated this unit. But before replacing the filter, I got to wondering what kind of video-signal distortion would give so much shading and still cause so little twist. Out of curiosity, I decided to scope the video output signal; the result is shown in Fig. 7B.

The large amount of distortion displayed here might be expected to cause severe twist, or even a total loss of sync. Since neither of these conditions existed, I determined to find out why. One more test, at the grid of the sync separator, supplied the answer. Positive peaks in the composite signal fed to the grid were limited, as shown in Fig. 8A—in effect, clipping the sync tips. The result was a high-quality sync signal (Fig. 8B) at the plate of the separator. Even after the defective filter was replaced, this last trace showed very little change.

Wrong Ripple Frequency?

After curing other troubles in a Motorola receiver, I was annoyed to find a billowy twist in the picture, as illustrated in Fig. 9A. Scoping a few key points, I soon had a

LONGER SERVICE LIFE • BETTER PERFORMANCE • GREATER CUSTOMER SATISFACTION

BE WISE... STANDARDIZE ON

ADMIRAL SUPERTRON RECEIVING TUBES

ALWAYS FINE / PRECISION QUALITY

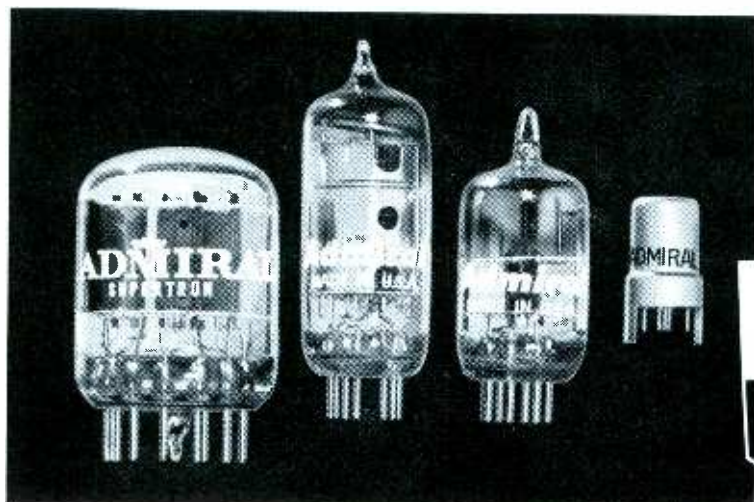

Engineered for peak performance... priced for extra profit! Every Supertron Electronic tube has passed rigorous SUPER-QUALITY control tests and life tests before they meet the high premium standards required for circuit approved tubes. And the remarkable Admiral price helps you make more dollar profit on every sale!



Order new ADMIRAL SUPERTRON RECEIVING TUBES now and start pocketing big profits right away. Call your ADMIRAL DISTRIBUTOR today!



Circle 69 on literature card

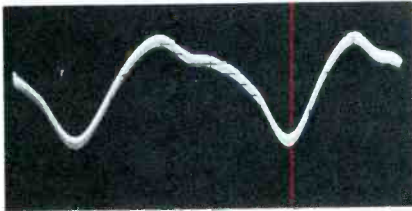

(A) At B+ source, 5V p-p

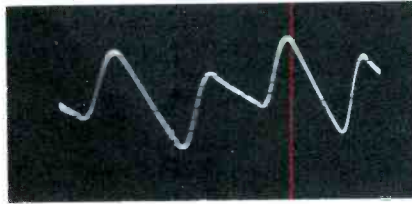

(B) At point A, 60V p-p

Fig. 11. Abnormal ripple waveforms.

clue: distortion in the video output signal (Fig. 9B) equivalent to the twist. Since the troublesome modulation appeared to be a 60-cps sine wave, I first assumed that a filament-circuit leakage must be present. I doubted the B+ supply was causing trouble, because this set develops B+ in a full-wave voltage doubler (Fig. 10), and any excessive ripple from the power supply would thus be expected to have a ripple frequency of 120 cps.

To check my surmise of filament trouble, I replaced the entire string of video-signal tubes—without any improvement. Finally, I scoped the B+ end of the plate-load resistor in the video output stage, and found 60-cps ripple (Fig. 11A). When I traced back to point A in the power supply, I finally found 120-cps ripple (Fig. 11B), but alternate cycles were so unequal in size that the waveform was easily transformed into a 60-cps ripple by further filtering. When I shunted a new electrolytic across C1, the waveform at point A resumed its



"That set was working perfectly; here's the one that needs fixing!"

normal shape (Fig. 12B), and the ripple on the B+ line settled down to the condition shown in Fig. 12A—with the sought-after result of removing the twist from the picture.

Conclusion

In this article, I've tried to concentrate mostly on fairly common twist troubles that are likely to be duplicated many times in various receivers. Freak conditions peculiar to certain models often take somewhat longer to cure, possibly because the serviceman blocks his own path by ignoring or refusing to



(A) At B+ source, 2V p-p



(B) At point A, 20V p-p

Fig. 12. Waveforms after the repair.

believe the available evidence. Nevertheless, even the worst "tough-dog" twist case will eventually respond to the type of analysis that has just been demonstrated. ▲

Model 301 COMBINATION TESTER

NEW

3 INSTRUMENTS IN 1

1

TUBE TESTER

2

CRT TESTER-REACTIVATOR

3

V.O.M.

20,000 OHMS PER VOLT



only \$10975
Slightly higher in the West

All hand wired . . . all American made . . .

Here is a complete portable service shop at your side wherever you go. Three of the most essential instruments are now combined into one compact unit . . . each section operating independently. . . . Save countless dollars . . . gain tremendous convenience as you work with the Model 301 in the shop and on calls. Features large 6" easy-to-read meter . . . long lasting etched aluminum panel. Housed in sturdy leatherette carrying case with special compartment for test leads and line cord. Size: 17½" wide x 13" high x 4½" deep.

TUBE TESTER SECTION . . . will test cathode emission, inter-element leakage and gas content of all present tube types and new tube types . . . NUVISTORS, COMPACTRONS, NOVARS, 10-PIN TUBES, battery type tubes, auto radio hybrid tubes, voltage regulators, foreign and hi-fi tubes, thyratrons and most industrial tube types • Advanced heater pin switching feature overcomes obsolescence caused by the introduction of new base pin arrangements.

CRT TESTER-REACTIVATOR SECTION . . . will test, repair and reactivate all black and white and all color picture tubes • Checks for shorts, leakage and emission • Eliminates inter-element leakage and shorts • Restores emission and brightness with a specially designed high voltage pulse • Exclusive feature enables you to watch the reactivation on the meter as it takes place — eliminating the possibility of over-activation • Provides correct filament voltages including the 2.35 and 8.4 volt types.

VOM SECTION . . . sensitivity is 20,000 ohms per volt/DC . . . 5000 ohms per volt/AC • **6 DC Voltage Ranges:** 0-15/75/150/300/750/1500 volts • **6 AC Voltage Ranges:** 0-15/75/150/300/750/1500 volts • **3 Ohms Ranges:** 0-1000/100,000/10 megohms (10 ohms center scale) • **5 DC Current Ranges:** 0-75 µa./7.5 ma./75 ma./750 ma./15 amps. • **2 Capacity Ranges:** .001-15/.1-80 mfd.

See your electronics parts distributor or write for complete literature



Mercury ELECTRONICS CORPORATION
manufacturers of quality electronic products

111 Roosevelt Avenue, Mineola, New York
Circle 70 on literature card

FOR SHARP, CLEAR 2-WAY COMMUNICATION

Fixed or mobile,
business or pleasure
Get the new, low-cost

RCA MARK VIII

27-Mc Citizens Band Radio-Phone



Here's the LOW-COST C-B radio-phone for car, boat, home, office, or shop. High sensitivity receiver pulls in weak signals. 2½ watt speaker output delivers ample volume to overcome engine noise. Automatic noise suppressor minimizes ignition interference. Light and compact—only 3½ inches high, weight only 9 pounds; fits easily under the dashboard of even compact cars.

PLUS THESE PREMIUM FEATURES— RCA MARK VIII RADIO-PHONE

- 9 crystal-controlled transmit and receive channels
- Tunable receiver permits reception of all 23 C-B channels; dial marked in both channel numbers and frequency
- Exceptionally good voice reproduction—high intelligibility
- Excellent modulation characteristics
- Operates from standard 117-volt AC; separate 6- and 12-volt DC power supplies (optional) for mobile installations
- Electronic switching—no relay noise or chatter
- Illuminated "working channel" feature plus many more features to increase usefulness and efficiency.

AC Unit only **\$149.50***

DC Power Supplies, Where Needed, \$19.95*
*Optional list price



The Most Trusted Name
in Electronics

—MAIL COUPON FOR MORE INFORMATION—

RCA Electronic Components & Devices
Commercial Engineering Dept. J-33-R
415 South Fifth Street, Harrison, N. J.

Please send more information on the RCA
Mark VIII 27-Mc 2-Way Radio-Phone.

Name _____

Address _____

City _____ Zone _____ State _____

Circle 71 on literature card

Infrared Energy

(Continued from page 26)

luminated by an external source of infrared energy such as a searchlight.

The infrared system may also be classified according to the type of detector element. "Thermal" or "non-image-forming" systems utilize the change in temperature of a detector such as a thermocouple or thermistor, while "photo" or "image-forming" systems utilize the effect resulting from absorption of a photon—as in infrared photographic film or the infrared image tube.

Passive systems, which detect an object by virtue of its own temperature, are relatively simple. Basically, they consist of the source of radiant energy, the medium through which the energy is transmitted, the optical and scanning system, the detector of radiant energy, and the signal processing and presentation system. A block diagram of a passive system is illustrated in Fig. 5.

The optical portion of such systems may be either a lens or mirror arrangement; it impinges the target radiation onto the sensitive detector element, which then converts the infrared energy into an electrical signal. Unwanted background radiation is also received, but since target and background radiation differ in wavelength, a filter may be placed in front of the detector to block undesired radiation and thus enhance the ratio between primary and background radiation.

The active infrared system of Fig. 6 is similar to the passive system just described except that a source of radiation is provided to illuminate the target. The reflected radiation is received by the detector in much the same manner as with the passive system.

Sources of Infrared Energy

Several different types of devices that emit infrared radiation are available to meet the diverse requirements of various applications.

Incandescent-filament lamps have been employed to a greater extent than any other type of radiation source; these lamps constitute a valuable and widely used source for near-infrared radiation. There are several reasons why the incandescent infrared lamp has gained such

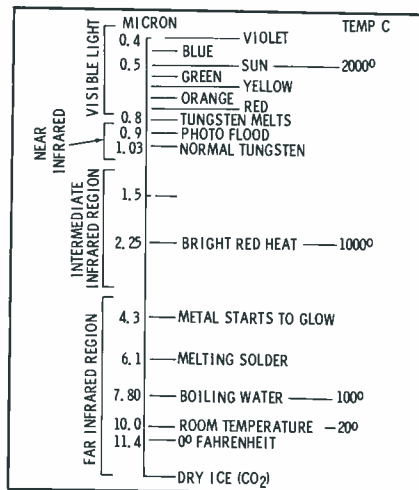

Fig. 4. Wavelength of peak radiation from object depends on temperature.

widespread popularity. (1) The tungsten filament lamp is the most efficient producer of near infrared—the wavelength of peak spectral radiant intensity lies near one micron for incandescent lamps operating at about 3000° Kelvin. (2) At higher temperatures, some ultraviolet is produced. (3) All of the radiation and electrical characteristics of tungsten are well known. (4) Finally, incandescent-lamp design and production facilities are readily available.

Another source of infrared energy, the *mercury-vapor lamp*, is one in which infrared and other radiations are produced by the excitation and ionization of mercury atoms. This type of lamp consists of an envelope which contains mercury vapor and two or more electrodes to deliver electrical power for starting and maintaining an arc discharge. Variations in the design of this lamp (vapor pressure, current, and voltage) are used to help control the distribution of the radiant energy generated by the lamp.

Mercury-vapor infrared lamps can be used for any application in which the incandescent lamp is used. In addition, a mercury-vapor lamp can be used in many applications where the large amount of heat generated by incandescent lamps makes them impractical.

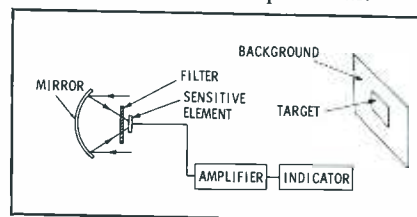
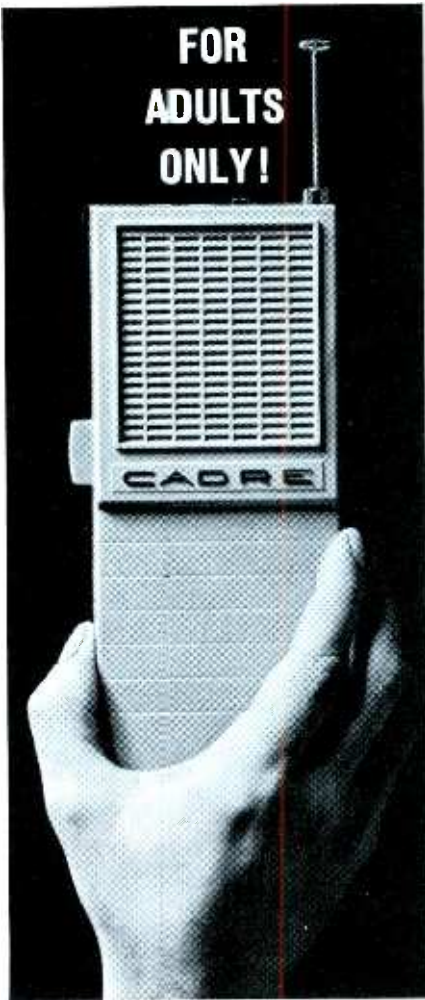

Fig. 5. A passive type of infrared system comprises these basic elements.

**FOR
ADULTS
ONLY!**



NEW CADRE C-75 CB TRANSCEIVER

The new Cadre C-75 1.5-watt, 2-channel transceiver is 15 times too powerful for youngsters (under 18 years of age) to operate, according to FCC regulations. Clearly, it's not a toy. It's designed for serious CBers who need 'big set' performance that can be used anywhere.

The new C-75, weighing less than 2 lbs; provides clear, reliable 2-way communications up to 5 miles and more. All solid state design creates an extremely rugged transceiver to absorb rough handling, stays on frequency. Two crystal-controlled channels spell perfect communications contact everytime. Sensitive superhet receiver (1 μ v for 10 db S/N ratio) brings in signals in poor reception areas. Powerful transmitter has one watt output to the antenna. Adjustable squelch silences receiver during standby. AGC assures proper listening level. In a word, the C-75 has all the features you'd look for in a quality full size CB unit.

The C-75 has all the portable conveniences you'd want, too: operates on alkaline or mercury penlite cells (8-hour rechargeable nickel-cadmium battery available); earphone and antenna jacks; built-in retractable antenna; jack for base operation while recharging.

Use the Cadre C-75 anywhere in the field, for vehicle, office, boat or plane. Use it constantly too, because its all-transistor modular circuit (11 transistors and 2 diodes) is virtually maintenance free. \$109.95. Recharger and 2 nickel-cadmium batteries \$31.85.

Cadre also offers a complete line of 5-watt all transistor transceivers and accessories. See your Cadre distributor or write

CADRE INDUSTRIES CORP.
COMMERCIAL PRODUCT DIVISION □ ENDICOTT, NEW YORK □ AREA CODE 607, 748-3373. Canada: Tri-Tel Assoc., Ltd., 81 Sheppard Ave. W., Willowdale, Ont. Export: Morhan Exporting, 458 B'way, N. Y. 13, N. Y.

Circle 72 on literature card

The *concentrated-arc lamp*, whose radiation characteristics are in many respects similar to those of the incandescent tungsten lamp, is another development of importance for systems that use infrared radiation. Typical examples of applications for this lamp are those which require radiant power of sufficient magnitude for transmission over long distances. Such instruments as these are used for infrared communications, infrared ranging and detection (IRRAD), autocollimators, cloud attenuation meters, and infrared aircraft landing systems.

A concentrated-arc lamp gets its name from the small cathode spot of high brilliance from which most of the radiation is emitted. These lamps consist basically of two permanent electrodes sealed into a glass bulb which is filled with argon gas at a pressure of one atmosphere. The unique radiation characteristics of this lamp are largely due to the cathode material, which is a specially prepared zirconium oxide.

The *cesium vapor lamp* can be used in signaling, active guidance, navigation, and similar applications. The radiation emitted by this lamp originates in the column of a low-pressure discharge in cesium vapor. About 20% of the input power to the lamp is radiated in the two cesium resonant lines at wavelengths of approximately 0.85 and 0.89 microns. The selective radiation characteristics and high efficiency of modulation of the cesium-vapor lamp probably approach the ideal realization of desirable characteristics for a specialized purpose as nearly as any infrared source.

For many years there has been a need for a method of heating that has the many advantages of infrared and at the same time provides higher concentrations of radiant energy. In order to meet this need, the *quartz infrared lamp* was developed. Physically, the lamp consists of a coiled tungsten filament

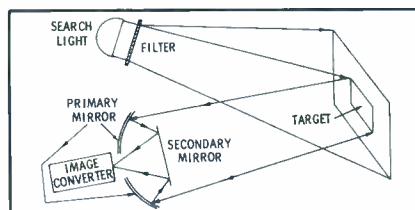
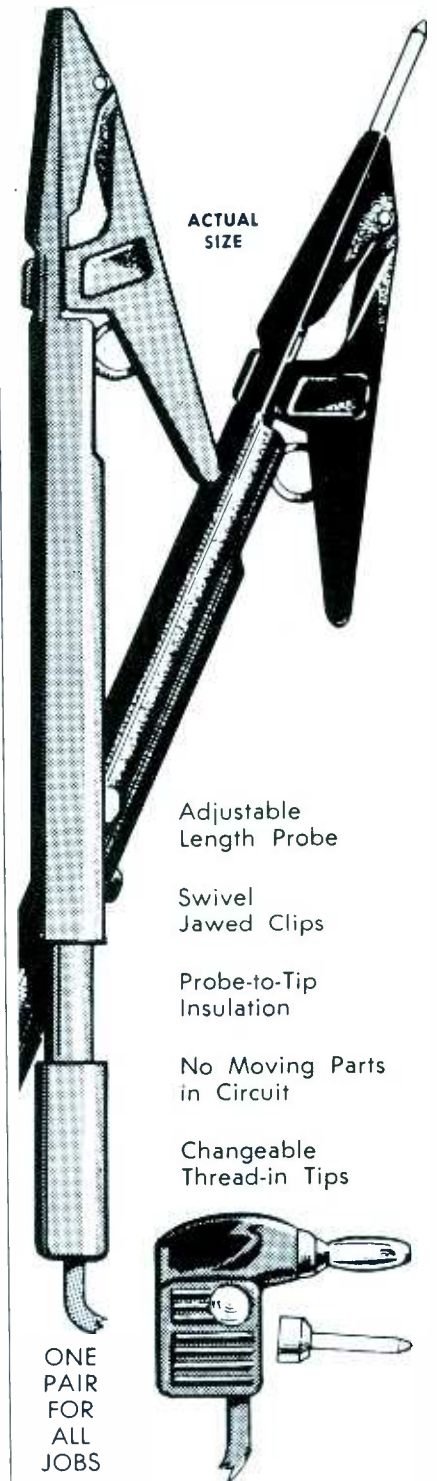

Fig. 6. An active system also incorporates a source of infrared radiation.

Newly Developed TEST LEADS Gator-Probe



ONE
PAIR
FOR
ALL
JOBS

Your Distributor Has All Information
About This New Product

GATOR-PROBE CORP.

HOLLISTER, CALIFORNIA

A Subsidiary of HOLEX Incorporated

Circle 73 on literature card

October, 1963/PF REPORTER 99

**You won't want to miss the
NOVEMBER ANNUAL
ALL COLOR-TV ISSUE!**

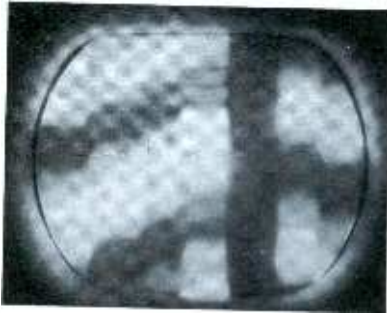

Color Symptom Clues

Photos that show how to localize defects in color sets.

Color Servicing . . . It's Easy!

An old pro tells how he got started.

Know Your '64 Color Circuits

8-page book section shows all the new chassis features.

Color TV Test Generators

Learn the different types, and how and why they're used.

Color Countermeasures Special

A valuable collection of all-new, down-to-earth solutions for common color-TV faults.

**Vertical Problems That Affect
Convergence**

How to contend with this annoying interaction between circuits.

Plus: Symfact

**Color TV Caddy Guide
CCTV in Color
Troubleshooter**

. . . and many more exclusive color features!

Enter my subscription to PF REPORTER and send me free book(s) checked.

- 3 Years \$10.00 2 Years \$8.00 1 Year \$5.00
 The Troubleshooter's Handbook
 Servicing Industrial Electronics
 Servicing TV from Tuner to Picture Tube
 Check one of above for each year you subscribe
 Bill Me Remittance Enclosed
 Extend Present Subscription

Please Check Your Business Classification

- Owner, Mgr. Employee Service Mgr.
 Independent Radio, TV Serviceman Retailer with Service Department
 Industrial Electronics Service Other (Specify occupation and title)

Name _____

Firm _____

Address _____

City _____ Zone _____ State _____

Take this coupon to your distributor, or mail to:
 Howard W. Sams & Co., Inc., 4300 W. 62nd Street,
 Indianapolis, Indiana.

1063

held in the center of a quartz tube approximately $\frac{3}{8}$ of an inch in outside diameter. Molybdenum foil lead wires sealed in the ends of the bulb are attached to the filament.

The radiant energy from quartz infrared lamps is very nearly the same as from other infrared lamps, since the color temperature of the filament is almost the same. However, quartz lamps radiate a portion of their energy beyond 5 microns. This is energy that has been absorbed by the quartz and reradiated. The luminous efficiency of quartz infrared lamps is essentially the same as that for other infrared lamps (approximately 8 lumens per watt).

Applications of Infrared Energy

One of the largest potential uses of infrared energy is in automation processes in chemical and glass plants. Since these manufacturing processes depend on heat for their operation, infrared instruments that detect heat changes can be used to regulate the processes from start to finish.

Infrared instruments can similarly be used for temperature measurement and control during manufacture of textiles, plastics, and metals; fire and incipient-explosion detection is also possible. Further applications are being developed in navigation, landing systems for aircraft, weather research, and numerous outer-space projects.

Personal communications by infrared devices can permit fire fighters to talk from the top of a ladder to the bottom; another use is in mine shafts, where wires cannot be laid and radios will not work well. In any area where power lines are down and portable radio equipment is engaged in net traffic, noninterfering point-to-point infrared communications equipment can aid in directing disaster apparatus.

Other applications for infrared are in photography, aerial mapping, and control techniques. There are, of course, countless applications of infrared energy where the heating effects alone—due to absorption of the radiant energy—are important. A few examples are therapeutic treatment, paint drying, the removal of tomato skins by blistering as an alternative to peeling, and—paradoxically — infrared *cooling*. ▲

Winegard

Dealer of the month



**MEYERS Television
and Sound Service**

RED OAK, IOWA

Winegard salutes this mid-west dealer, whose motto is "Quality Merchandise Plus Customer Satisfaction"...and its distributor, Mid-State Distributing Co., Des Moines, Iowa.

Floyd Keeton, owner and operator of Meyers TV and Sound Service, has five years of success to show for his belief in quality. Covering a 50-mile radius from his shop in Red Oak, this one man operation is really kept hopping, and often requires extra help to handle large antenna installations in motels, hotels, apartment houses, etc.

Mr. Keeton backs up his belief in quality merchandise with the use of Winegard Antennas. "We have sold and installed all types of TV and FM antennas and it is our finding by actual test and by customer satisfaction that Winegard antenna systems have outperformed all others, whether it be a one TV set installation or larger multiple commercial system," he says.

"We found with the use of Winegard antennas and amplifier systems that there is no installation too large or too small that we can't fulfill."

Winegard
ANTENNA SYSTEMS

D3009-10 Kirkwood • Burlington, Iowa
 Circle 74 on literature card

PRODUCT report

For further information on any of the following items, circle the associated number on the Catalog & Literature Card.



Two-Way Radio Series (150)

An addition to the UHF two-way radio market is the new 400-420 and 450-470 mc **Communications Co.** 684 Series.

The Model 684 "Ultra Basecom," mounted in a modern-styled, silhouette cabinet, and the "Ultra Fleetcom" mobile units provide a UHF radio system featuring high transmitter power for extended range, and exceptional audio fidelity for easily understood messages. The compact, lightweight, "Fleetcom" mobile units combine the control head, speaker, and transistorized power supply in one small, easily-mounted assembly no longer than a conventional speaker housing. The all-transistor mobile power supply is available for operation from 6/12, 12, or 24 volts DC. The mobile package — for either dash or trunk mounting—includes a high-gain, rooftop antenna. The Model 684 "Portacom" is housed in a hand-carried case with self-contained speaker and controls.

The base and mobile transmitters provide 20 to 25 watts output, with all stages protected by fixed bias. A new and improved audio-limiting circuit, which increases message clarity, has been in-

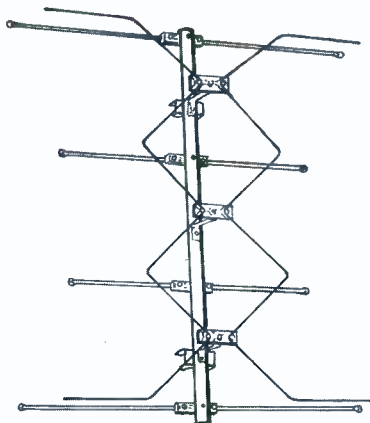

UHF Antennas (151)

Two new UHF antennas are available from **Antennacraft**. The Model G-1483 is for all channels from 14 through 83, and the G-7083 for channels 70 to 83 only. Both models consist of aluminum-wire driven elements with a diamond-phase design which eliminates loose connections. Available in either a "dura-gold" or blue anodized finish, the rod-type reflectors present little wind resistance. The antennas incorporate high-impact plastic insulators and rustproof aluminum terminals to minimize weathering or aging. With the gold finish, the antennas are priced at \$8.95; with the blue, \$10.95.

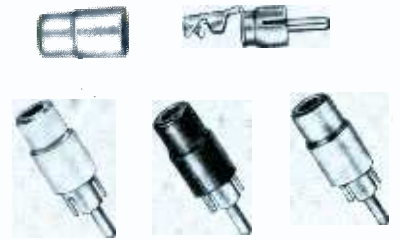

Colored Phono Plugs (152)

A new line of phono plugs manufactured by **Switchcraft** features positive cable clamping to minimize strain on the cable connections. Priced at 25¢ each, the Series 3508 phono plugs are designed for use in virtually all types of electronic equipment. With a red insulating sleeve, the plug carries a part number of 3508-1; with a black sleeve, 3508-2; with a white sleeve, 3508-5. Other colors are available on request.

Headphone-Microphone Combination (153)

A headband-mounted combination earphone-microphone offered by **Astatic** is designed to be user-proof. The "Astaticphone" can withstand continual pulling off and on without wires becoming disconnected or the phones or mike becoming too loose to stay in position. Two monophonic models are offered, with or without microphone. The ceramic headphone Model 2501 and crystal headphone Model 2601 are supplied without a mike; the ceramic headphone Model 2503 and the crystal headphone Model 2603 are equipped with a ceramic boom mike. Models 2501 and 2503 both have 20K impedance at 1000 cps, and a frequency response of 30 to 10,000 cps; the 2601 and 2603 have 100K impedance at 1000 cps, and a frequency response of 30 to 8500 cps. The ceramic mike also has a response of 30 to 8500 cps, but with 200K impedance at 1000 cps.

The headphones, and mike are adjustable for maximum user comfort; the ear cups are fashioned to provide an effective seal against background noise. All parts that come in contact with the head are made of soft, resilient material that is bacteria-proof and will not be affected by skin excretions and cosmetics. Weighing 8.5 oz, the 2501 and 2601 sell for \$25.75 and \$22.75, respectively; the 2503 and 2603, weighing 10.5 oz, cost \$37.75 and \$35.25, respectively.





Raise Your CB Power (154)

By utilizing the maximum legal aperture allowed for CB antennas, and thus capturing the greatest amount of signal area, **Hy-Gain's** new CLR II collinear antenna is able to develop up to 3.4 db of gain from all directions in the receive mode, and as high as 8 db gain (double the effective radiated power) in the transmit mode.

The radiator of the CLR II is 19' 10" high and is electrically extended to $\frac{5}{8}$ wavelength. Full 9' horizontal radials at the bottom of the antenna provide a $\frac{1}{4}$ -wave ground-plane system. The $\frac{5}{8}$ -wave radiator, working against the ground plane, produces a very low angle of radiation and directs maximum energy along the horizon for greatest effective range. A built-in static arresistor minimizes lightning hazard to the antenna and equipment. The CLR II, priced at \$29.95, also features a moistureproof, solid-state matcher that is permanently weather-protected and delivers an SWR of less than 1.2:1.

"Chic" Changer (155)

Features of a new replacement-type record changer, built by **Maestro**, include a lift-pin safety device in the mechanism and a spindle-arm arrangement that maintains a balanced record stack. The lift-pin prevents damage to either the mechanism or tone arm if the machine happens to cycle with the tone arm clipped to the rest post. With the record stack balanced on the spindle, records drop evenly when released. Another feature is the incorporation of "legs" to protect the mechanism during servicing. The drive idler disengages in the "off" position to prevent flat spots from developing. The mechanism includes a built-in antiskate device to make the needle landing extremely gentle.



Transistorized Ignition (156)

A new, inexpensive transistorized auto ignition system called "Trans-It" has been developed by **Workman** for use in both 6- and 12-volt autos and trucks. The system uses only two transistors and does not need a special coil; the existing ignition coil becomes part of the transistorized system. Unlike in conventional ignition systems, a strong spark voltage is maintained with this unit, even at high engine speeds. Both 6- and 12-volt units will operate only on cars with negative battery ground. The Model BX-14A is used for 6 volts; the BX-14 for 12 volts; both are priced at \$17.95 list.

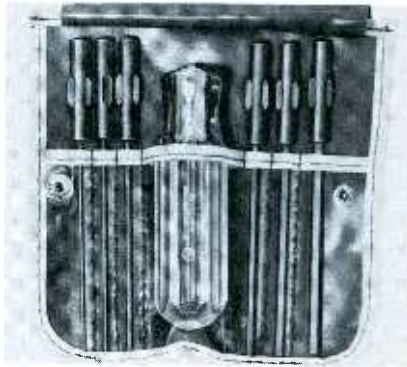

Allen Hex Screwdrivers (157)

Fixed-handle Allen hex screwdrivers are available from **Xcelite** in eleven sizes from .050" through $\frac{1}{4}$ ". Long, 4" blades on smaller sizes and 6" blades on larger ones provide plenty of "reach" to get at deep-set or awkwardly placed screws. In close quarters, these drivers offer greater speed and ease in turning than conventional "L" wrenches or keys. The alloy steel blades are permanently embedded in shockproof, breakproof, amber plastic handles.

Detachable Allen hex blades, which fit handles provided in the Xcelite Service Master and other "99" Series tool kits, are also available. They are made in eight hex sizes from $\frac{1}{16}$ " through $\frac{3}{16}$ " with a blade length of 4". These blades may be purchased singly or as a set of 6 in a free plastic pouch which has numbered compartments that simplify selection of the proper blade. They are also offered in a roll kit which contains the six blades plus the regular $1 \frac{1}{16}$ " x $4 \frac{1}{8}$ " handle.



Roving Rostrum (158)

The "Roving Rostrum" is a battery-powered portable sound system whose carrying case opens to form a self-contained lectern. Manufactured by **Perma-Power**, the Model S110 can be set up anywhere to provide instant, efficient public-address facilities. Operating entirely from long-lasting flashlight batteries, the Roving Rostrum provides up to 25 watts of transistorized audio power from its own speakers. The luggage-type unit contains two speakers—one in the lectern, and the other in the cover. The latter can be situated up to several feet away from the lectern for better audience coverage. The lectern supports a low-impedance omnidirectional mike, and contains a flat surface for notes and papers. Retractable legs can be adjusted for reading height and tilt angle.

Available at extra cost are: a mike extension kit for audience participation, an AC power supply, and an AC-operated reading lamp. A cardioid microphone is part of the Model S120, which is identical to the S110 in every other respect. The Model S110 sells for \$149.95, and the S120 for \$189.95; each weighs approximately 22 lbs.

"Duo-Band" FM Receiver (159)

"Duo-Band" is the name of a new FM receiver for monitoring business, police, fire, taxi, trucking, and mobile-telephone VHF transmitters. Manufactured by **Utica Communications**, the "Duo-Band" is capable of receiving both the low and high bands—35-50 mc and 152-174 mc, respectively. This dual-conversion super-het features a tuned RF stage, crystal-controlled second oscillator, squelch to quiet internal circuit noise, and temperature compensation to minimize frequency drift. It operates from 110 volts AC, 60 cps, and is priced at \$164.95.

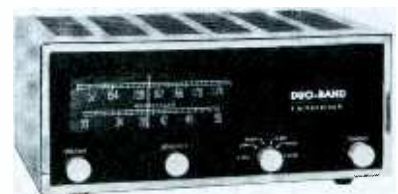



Aluminum-Cone Speaker (160)

The spun aluminum cone in the Model WP44 speaker introduced by Utah cannot absorb moisture, nor is it harmed by prolonged exposure to sunlight. This speaker is engineered for long life in outdoor use; weather and usual wear and tear have little effect on this tough, yet resilient material. The cone is produced by a patented spinning process which reduces the cone stock to but a few mils in thickness. In this form, the aluminum stock possesses an excellent frequency-response characteristic. The speaker is available in the 4" size, has a 3.2-ohm voice coil, and will handle up to 4 watts of power.

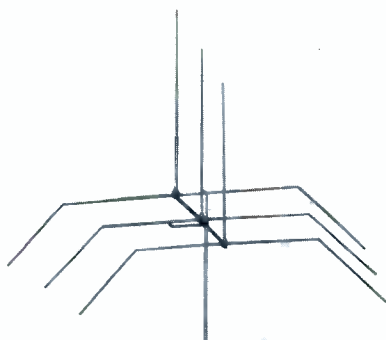

Two-In-One CB Antenna (161)

A CB beam antenna that can be polarized either vertically or horizontally has been developed by Antenna Specialists Co. Designated the MR-77, this antenna is fed by two separate transmission lines—one for the vertical elements and one for the horizontal. Changing the transceiver connection from one feeder line to the other is normally a manual operation, but can be facilitated by a coaxial switch located close to the operator.

The "Match Maker" produces a forward gain of 7 db in the vertical plane, and 6 db in the horizontal. Its front-to-back ratio in either plane is 15 db. The boom and antenna elements are made of heat-treated aluminum, clamped together firmly enough to withstand 100-mph winds. The MR-77 is 12½" high, with a boom length of 10', and weighs 24 lbs. The antenna is gamma matched to 50-ohm lines, with a VSWR of 1.5:1 or less.



Tape Recorder "Test Tape" (162)

A 7" "Test Tape" for the amateur and professional tape recordist is now being offered by the Burgess Battery Co. With this tape the recorder can be checked at both 3¾ and 7½ ips for maximum "record" and "playback" efficiency without additional test gear. The "Test Tape" also contains a step-by-step explanation of how to check for fidelity, balance, timing, and frequency response. In addition, it teaches production techniques such as sound on sound, splicing, and editing, and suggests other ways to use tapes and recorders. All in all, 21 detailed tests are given on this \$8.00 tape.



Transistorized PA Amplifiers(163)

A line of 15-, 30-, and 60-watt all-transistor PA amplifiers is now in production by the B & K Mfg. Co. The 15-watt model, designed for portable, fixed, or mobile operation, is equipped for 117-volt AC operation and has a cigar-lighter attachment for use in any 12-volt vehicle. Power output is 15 watts rms (30 watts peak), with frequency response of 20-20,000 cps ±2 db, and harmonic distortion less than 2%. Output impedances are 4, 8, and 16 ohms; 70.7-volt output is available for constant-voltage operation.

The 30- and 60-watt models operate from 117 volts AC and include a special control that enables the operator to reduce annoying acoustic feedback, even while increasing amplifier gain. These models also have provisions for separate or simultaneous use of more than one microphone. (Low-impedance microphone transformers can be plugged directly into the amplifier chassis.) Two extra inputs are provided for use with a tuner, tape recorder, or other auxiliary equipment. Power ratings are 30 watts rms (42 watts peak) and 60 watts rms (84 watts peak), into impedances of 4, 8, 16, or 500 ohms. These models also provide 25-, 50-, and 70.7-volt outputs for constant-voltage use.

Acme Electric Corp.	60
Admiral Sales Corp.	96
Antennacraft Co.	33
Antenna Specialists Co., The	94
Arrow Fastener Co., Inc.	92
ATR Electronics, Inc.	12

B & K Mfg. Co.	
Div. of Dynascan Corp.	47, 55, 58
Beauchaine & Sons, Inc.	86
Berns Mfg. Co., Inc., The	58
Blonder-Tongue Labs	77
Bussmann Mfg. Div.	24-25

Cadre Industries	99
Castle TV Tuner Service	18
Centralab, Div. of Globe-Union, Inc.	57
Channel Master Corp.	40-41
Charles Engineering, Inc.	56
Cleveland Institute of Electronics	87
Columbia wire & Supply Co.	12

EICO Electronic Instrument Co., Inc.	72, 95
Electro-Voice, Inc.	65
Enterprise Development Corp.	90
Finney Co.	53

Gallo Electronics	49
Gator Probe Corp.	99
GC Electronics Co.	88
General Electric Co.	
Receiving Tube Dept.	22-23, 42-43
Greyhound Corp.	61

Hickok Electrical Instrument Co.	63
ITT Distributor Products Div.	67

Jensen Mfg. Co.	75
Jerrold Electronics	28, 59
JFD Electronics Corp.	45
JW Electronics	56

Lectro-Tech, Inc.	68
Littelfuse, Inc.	4th Cover

Mallory, P. R. & Co., Inc.	69
Mercury Electronics Corp.	97
Mercury Tuner Service, Inc.	64
Merit Coil & Transformer Corp.	93
Mosley Electronics, Inc.	80
Motorola Training Institute	86

Oaktron Industries, Inc.	64
Ohmite Mfg. Co.	84
Perma-Power Co.	83
Philco Corp.	19, 48
Precision Tuner Service	66

RCA Electronic Components and Devices	91, 3rd Cover
Commercial Engineering Dept.	98
RCA Parts and Accessories	71
RCA Sales Corp.	81

Sams, Howard W. & Co., Inc.	73, 94
Sarkes Tarzian, Inc.	
Semiconductor Div.	89
Tuner Service	9
Seco Electronics, Inc.	79, 85
SENORE, Inc.	13, 14, 15
Sonotone Corp.	70
Sprague Products Co.	10
Standard Kollsman Industries, Inc.	2nd Cover
Switchcraft, Inc.	92
Sylvania Electric Products, Inc.	
Electron Tube Div.	16-17

Trio Mfg. Co.	50, 51
Triplet Electrical Instrument Co.	52

Volkswagen of America, Inc.	27
Westinghouse Electric Corp.	78-79
Winegard Co.	20-21, 100
Workman Electronic Products, Inc.	60
Xcelite, Inc.	66

ANTENNAS & ACCESSORIES

84. **ANTENNACRAFT** — Catalog sheets, illustrated in color, with complete performance and pricing information on new *Gold Bonanza (VHF)* and *Gold UHF* antennas—single, stacked, or in kits.*
85. **BLONDER-TONGUE** — 8-page booklet "UHF is Coming to Your Town"; explains potential of new all-channel UHF market opening to service technicians.*
86. **CHANNEL MASTER** — Brochure describing *Super-Crossfire* high-gain antenna, designed for both stereo-FM and TV reception.
87. **GALLO**—Descriptive brochure on FMS-101, an FM antenna system with transistorized preamplifier, entirely contained within decorative 6½" x 3¾" x 1-3/16" case.*
88. **JERROLD ELECTRONICS** — 6-page, color-illustrated catalog on *Paralog*, new line of log-periodic antennas with modular parasitic elements, for TV and FM installations.*
89. **JFD** — Specifications and operating information on *Transis-tenna* and newly designed, long-range LPV log-periodic TV antennas. Illustrated brochure showing entire line of indoor antennas and accessories for TV and FM. Data sheets on UHF antennas.*
90. **MOSLEY ELECTRONICS**—Illustrated catalog giving specifications and features on large line of antennas for Citizens band and amateur applications.
91. **WINEGARD**—New Fact-Finder booklet No. 224 on TV-FM outlets for home or large-area antenna system installations, including 75-ohm units.*
92. **ZENITH**—Informative bulletin on new line of log-periodic vee-type antennas for FM, and for monochrome and color TV.

AUDIO & HI-FI

93. **ATLAS SOUND, Div. of American Trading and Production Corp.**—New illustrated catalog 563, containing specifications of microphone stands and loudspeakers for use in public address, commercial, or industrial installations.
94. **BRITISH INDUSTRIES**—Four comparative guide booklets containing information on *Garrard* automatic changers, *Wharfedale* speaker systems, *Gold Lion* vacuum tubes, and *Multicoore* solder.
95. **ELECTRO-VOICE**—High-Fidelity catalog No. 159, a buyer's guide to component loudspeakers, accessories, and kits.*
96. **EUPHONICS** — Four informative brochures illustrating ceramic phono cartridges and microphones; cartridge cross-reference index is included.
97. **MINNEAPOLIS SPEAKER**—Descriptive catalog with illustrations of new weatherproof *Music Mini-Speaker* for indoor or outdoor hi-fi reproduction.
98. **OAKTRON**—"The Blueprint to Better Sound," an 8-page catalog of loudspeakers and baffles giving detailed specifications and list prices.
99. **QUALITONE** — Wall charts with needles pictured, for cross-reference of all popular needle replacement needs.
100. **QUAM-NICHOLS** — *Speaker Replacement Guide* listing the speakers used in all automobiles from 1955 through 1962.
101. **SONOTONE** — Technician's replacement guide on new *Sono-Flex* flexible needle. Brochure lists phonograph manufacturer's model number and Sonotone cartridge number.*
102. **SWITCHCRAFT**—Bulletin No. 129 describing new series 3508 color-coded phono plugs, with snap-on colored handles and positive-grip cable clamp; simplified stereo, hi-fi, and test equipment hookups.*
103. **UTAH** — Catalog listing complete line of speakers and accessories for high-fidelity and public-address equipment. Also contains speaker replacement data.

COMMUNICATIONS

104. **CADRE**—New booklet "Businessman's Guide to Citizens Band 2-Way Radio" answers questions, and explains uses for 2-way in commercial operations.*
105. **RAYTHEON** — Descriptive sheet on *Ray-Tel* CB communications system, using solid-state frequency synthesizer.

COMPONENTS

106. **BUSSMANN**—Bulletin SBCU on Buss Fustat Box Cover Units offers simple, low-cost way to protect workbench tools, soldering irons, drills, and the like against damage and burnout. Units fit standard outlet or switch boxes; have fuseholder, plus a plug-in receptacle,

- switch, and pilot light.*
107. **COLUMBIA WIRE** — Comprehensive catalog 110 describing many service-dealer wire needs plus an array of multicolor coax cables.*
108. **CLAROSTAT** — Information on new *Uni-Tite* Service Center for selecting and assembling dual concentric controls.
109. **LITTELFUSE** — Form L-562 showing prices and specifications on complete line of fuses, fuse holders, and merchandising aids.*
110. **MALLORY** — Condensed catalog of semiconductors (No. 9-334), listing silicon rectifiers, pre-packaged rectifier circuits, and zener diodes.*
111. **PERMA-POWER** — Descriptive literature on full line of CRT brighteners for color and monochrome receivers.*
112. **SPRAGUE**—Latest catalog C-615 with complete listings of all stock parts for TV and radio replacement use, as well as *Transfarad* and *Tel-Ohmite* capacitor analyzers.*
113. **STANCOR ELECTRONICS** — Durable wallcard tabulating proper output transformer to use with each of 260 different audio output tubes; includes specifications for each transformer recommended.
114. **TRAD**—New catalog TV-63/64 lists many replacement items for radio, TV, and hi-fi.
115. **WALDOM**—New catalog PMR-3 gives complete list of packaged electronic and electrical products "for prototype, maintenance and repair." Includes such items as solderless terminals and connectors, hardware, tube sockets, and terminal strips. Comprehensive list of speakers for foreign-made transistor radios helps technician to select replacement types.

SERVICE AIDS

116. **CASTLE**—How to get fast overhaul service on all makes and models of television tuners is described in leaflet, which also contains a comprehensive list of universal and original-equipment tuners. Shipping instructions, labels, and tags are also included.*
117. **COLMAN** — New 1963-64 catalog of radio-TV replacement components and service aids.
118. **ELECTRONIC CHEMICAL CORP.** — Catalog listing chemical sprays for cleaning and lubrication in all types of electronic equipment.
119. **INJECTORALL** — New 1963 catalog showing complete line of chemicals used in electronics.
120. **PRECISION TUNER**—Literature supplying information on complete, low-cost repair and alignment services for any TV tuner.
121. **STANDARD KOLLSMAN** — Tuner replacement guide, covering all TV sets from 1947 through 1962, with replacement parts listings.*
122. **WORKMAN** — General catalog CAF-102, fusible resistor and circuit breaker cross-reference guides, information on transistorized auto ignition system, and power converter sheet 25C.*
123. **YEATS**—The new "back-saving" appliance dolly Model 7 is featured in a four-page booklet describing feather-weight aluminum construction.

SPECIAL EQUIPMENT

124. **ACME ELECTRIC**—Complete specifications and applications for control-type magnetic amplifiers with capacities from 5-1000 watts and voltage ranges from 24-160 volts.*
125. **ATR**—Descriptive literature on selling new, all-transistor *Karadio*, Model 707, having retail price of \$29.95. Other literature on complete line of DC-AC inverters for operating 117-volt PA systems and other electronics gear.*
126. **ARROW FASTENER** — Leaflets describing Model T-75 cable tacker, T-85 and T-18 low-voltage wire tacklers, for speeding cable and wire installations. Illustrations showing methods used for various wire thicknesses are also included.*
127. **GC ELECTRONICS**—Giant-sized catalog FR-65 contains 330 pages, forming the most complete listing yet published of new products and equipment offered by all company divisions.*
128. **GREYHOUND**—The complete story of the speed, convenience, and special service provided by the Greyhound Package Express method of shipping, with rates and routes.*
129. **TERADO**—Sheet depicting wide line of 60-cps mobile power inverters and several types of battery chargers.
130. **UNITED PARCEL SERVICE** — Special story booklet, written for the general public, gives an inside look at

"Today's Radio-TV Repairman" and some aspects of his business.

131. **VOLKSWAGEN**—Large, 60-page illustrated booklet "The Owner's Viewpoint" describes how various VW trucks can be used to save time and money in business enterprises; includes complete specifications on line of trucks.*

TECHNICAL PUBLICATIONS

132. **CLEVELAND INSTITUTE OF ELECTRONICS** — "Pocket Electronics Data Guides" with handy conversion factors, formulas, tables, and color codes. Additional folder, "Choose Your Career in Electronics," describes home-study electronics training programs, including preparation for FCC-license exam.*
133. **HOWARD W. SAMS**—Literature describing popular and informative publications on radio and TV servicing, communications, audio, hi-fi, and industrial electronics; including special new 1963 catalog of technical books on every phase of electronics.*

TEST EQUIPMENT

134. **ANTRONICS** — General catalog describing Anchor Model T-475 *Reacto-Tester*, which repairs, analyzes, and tests every type of picture tube.
135. **B & K**—Catalog AP-21R describing uses for and specifications of new Model 1074 Television Analyser, Model 1076 Television Analyser, Model 850 Color Generator, Model 960 Transistor Radio Analyser, new Model 445 CRT Tester-Rejuvenator, new Model 250 Substitution Master, Model 375 *Dynamatic* VTVM, Model 360 *V-O-Matic* VOM, Models 700 and 600 *Dyna-Quik* Tube Testers, and Model 1070 *Dyna-Sweep* Circuit Analyzer.*
136. **EICO**—Catalog sheets on new Model 430 small general-purpose oscilloscope with 3" screen, and on Model 902 IM-Harmonic Distortion Meter and AC VTVM. Booklet "Short Course For Novice License" is also available.*
137. **HICKOK** — Complete descriptive and operating information on Model 661 *Chrom-Aligner* standard NTSC color-bar generator.*
138. **JACKSON**—Complete catalog describing all types of electronic test equipment for servicing and other applications.
139. **MERCURY ELECTRONICS** — Catalog giving full information on Models 1000, 1100, and 1200 Tube Testers, Models 202 and 203 Self-Service Tube Testers, new Model 301 Combination Tester, new Model 501 Component Substitutor, and Model 800 CRT Tester-Reactivator.*
140. **SECO** — Sheet No. FC6-S1 contains setup information to update tube indexes for Model 107 and 107A tube testers.*
141. **SENCORE** — Special, newly released data on color test equipment, including the entirely new low-cost CG126 Color Generator, CA122 *Color Circuit Analyzer*, and PS120 *Wide-Band Scope*.*
142. **SIMPSON**—Latest series of VOM's are described in test-equipment bulletin; also information on line of automotive test equipment.
143. **TRIPLETT**—Catalogs displaying complete line of test equipment for servicing, and industrial meters for all purposes.*

TOOLS

144. **BERNS**—Data on unique 3-in-1 picture-tube repair tools, on *Audio Pin-Plug Crimper* that enables technician to make solderless plug and ground connections, and on new-style *ION* adjustable "beam bender" for CRT's.*
145. **ENTERPRISE DEVELOPMENT** — Time-saving techniques in brochure from Endeco demonstrate improved desoldering and resoldering techniques for speeding up and simplifying operations on PC boards.*
146. **EVERSOLE** — Sheets describing and listing prices of *DeSod* desoldering tools for removing and replacing parts on printed circuit boards, including new tip for miniature IF transformers.

TUBES AND TRANSISTORS

147. **AMPEREX** — Catalog specifically devoted to extensive line of silicon planar epitaxial transistors. Describes applications for different types, with their basic specifications.
148. **SEMITRONICS**—New updated 16" x 20" wall chart CH7 lists replacements, with substitution data, for 2000 U.S. and foreign transistors.
149. **GRODEN INC.**—New, condensed semiconductor catalog listing complete line of components.

*Check "Index to Advertisers" for further information from this company.

DANGER
HIGH VOLTAGE

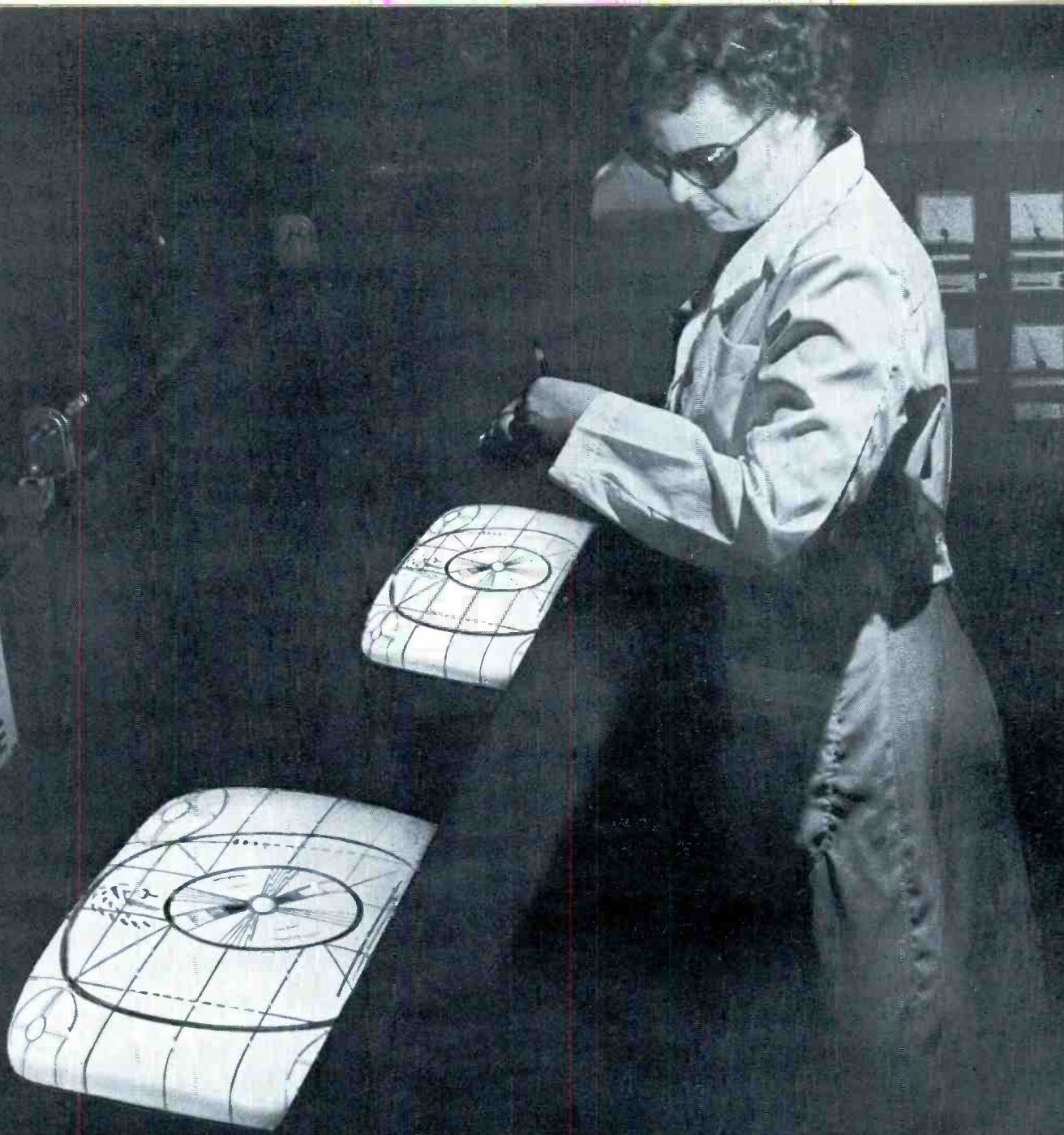

TRAP FOR FAULTY PICTURE TUBES

RCA Guards Against Callbacks 26 Ways

Under the watchful eyes of trained inspectors, RCA Silverama® Picture Tubes are carefully scrutinized for screen quality and focus.

All Silverama replacement picture tubes as well as those destined for original equipment undergo a battery of 26 automated tests. These include: warm-up, emission, gas, leakage, electron-gun performance, and other critical factors that can spell the difference between long-term performance or costly callback. Tubes failing a single test are automatically tagged and rejected. In addition to automatic testing, every tube lot leaving the RCA plant has been sampled by Quality Control.

Nothing is left to chance; part by part, inside and out, from base to faceplate the quality of each tube has been carefully controlled and assured prior to assembly. Even the Silverama envelope is carefully inspected prior to re-use, and is internally scrubbed, buffed, and restored to the peak of its optical capabilities. Result: a superior picture tube, an RCA Silverama. Make it your next installation choice.

RCA ELECTRONIC COMPONENTS AND DEVICES, HARRISON, N. J.



The Most Trusted Name in Electronics

Circle 75 on literature card

www.americanradiohistory.com



CARRY EACH SILVERAMA FACTORY-FRESH INTO YOUR CUSTOMER'S HOME. New Foam-Lined RCA Picture Tube Tote Bag makes scratched, marked, or scuffed faceplates a thing of the past. Makes carrying both easier and safer. Two sizes: one for 16" to 19" tubes, one for 20" to 24" tubes.

SEE YOUR AUTHORIZED RCA PICTURE TUBE DISTRIBUTOR FOR DETAILS

See the caddy



See the fuse box
through the caddy

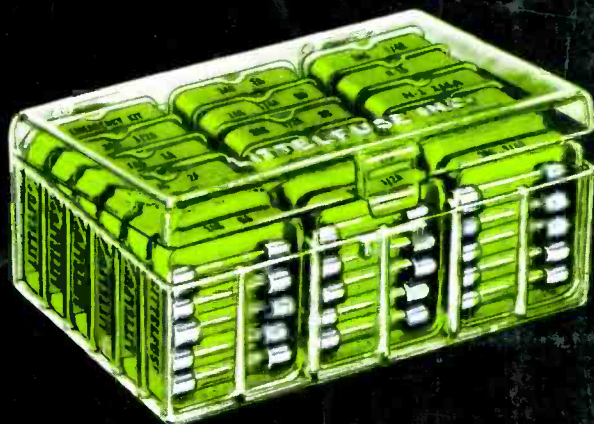

See the fuses
through the
fuse box
through the caddy



See more profits through

LITTELFUSE

DES PLAINES, ILLINOIS

Circle 76 on literature card

www.americanradiohistory.com