

OCTOBER, 1961

35 CENTS



PHOTOFACT REPORTER

Including **Electronic Servicing**

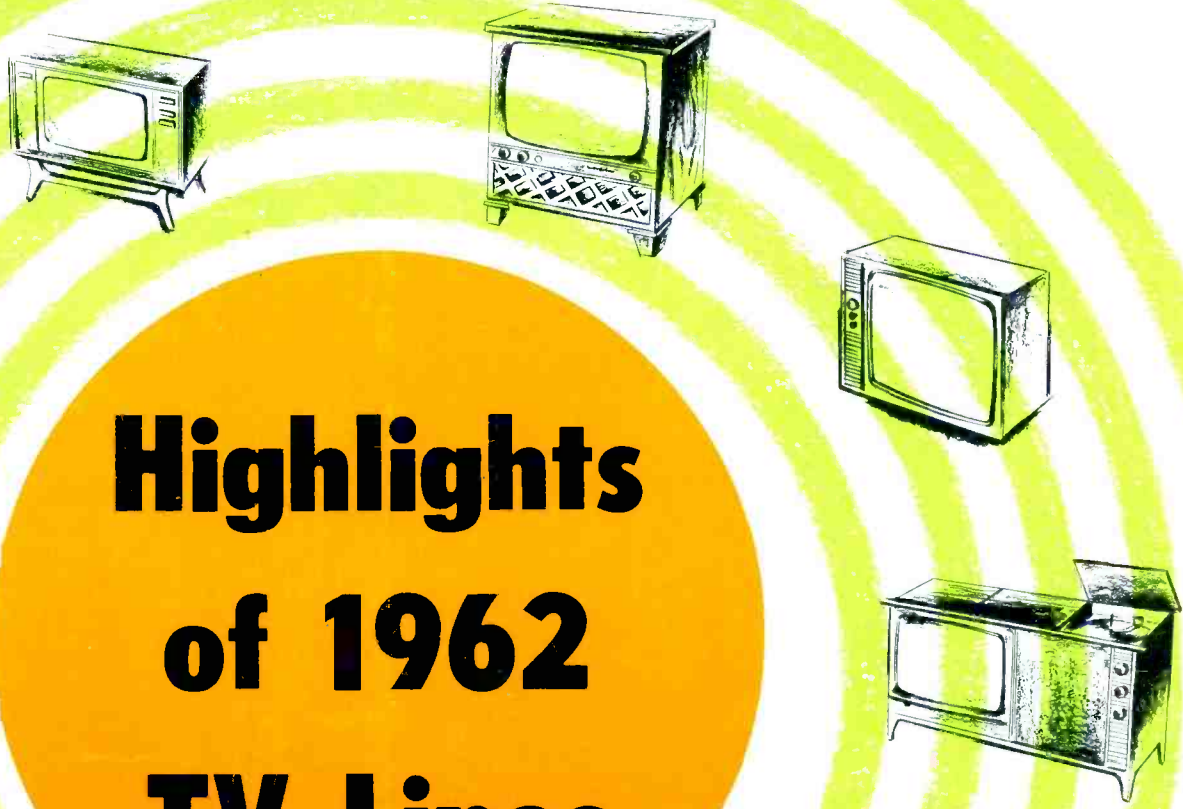

Highlights of 1962 TV Lines

Phono Cartridge and Needle Replacement Guide

Blast Those TV Intermittents

Painless TV Alignment

IA OK 7496 1264
WV. M. DAVIS
RAD. & TV SERV.
118 RIVERSIDE AVE.
CANON CITY, COLO.

Standard Made It...



STANDARD CAN FIX IT BEST

\$11⁵⁰ Plus Parts . . . **\$13.50 Maximum Total Cost**

FREE Specially designed shipping cartons to prevent damage in transit

**6 Months
GUARANTEE**

Only **BRAND NEW PARTS** Used • 48 Hour
Service on All **STANDARD Tuners** • Latest
Testing Techniques Assure Proper Alignment •
\$3.00 Defective Tuner Trade-in Allowance
Against a New **STANDARD Replacement Tuner**
Carrying a 12 **MONTH GUARANTEE**

IN TV IT'S *Standard*

STANDARD has maintained uniform mounting centers for the last 13 years. Over 50% of the TV sets in existence today have STANDARD tuners—in the case of most other tuners one of the 3 STANDARD replacement models can be easily adapted or will fit directly in place of these units. All STANDARD replacement tuners carry a 12 Month Guarantee.

**SEE YOUR AUTHORIZED
STANDARD DISTRIBUTOR**

**MORE PROFIT FOR THE SERVICE DEALER • GREATER CUSTOMER SATISFACTION
GUARANTEED BY THE WORLD'S LARGEST TV TUNER MANUFACTURER**

standard kollman INDUSTRIES INC.
FORMERLY STANDARD COIL PRODUCTS CO., INC., MELROSE PARK, ILLINOIS

Another cycle of new TV models is in full swing. The '62 sets are already pouring into the market; by next summer, over 6 million are expected to be in use. What do these new models have to offer, and what trends in receiver design do they reveal? Since these questions are of great interest to service dealers and technicians, the next eight pages are devoted to presenting the answers. Thumbnail reports on each manufacturer's line bring out the main points of interest, and a large chart provides a quick reference to the key technical features of all new chassis on the market. If you're a serviceman, this information will help you get ready for future service calls. If you sell sets, here's a chance to learn about the major selling points of all lines.

One major development is missing from this report—the sudden upswing of interest in color TV this fall. This story will be saved until next month's issue, which will be devoted entirely to color.

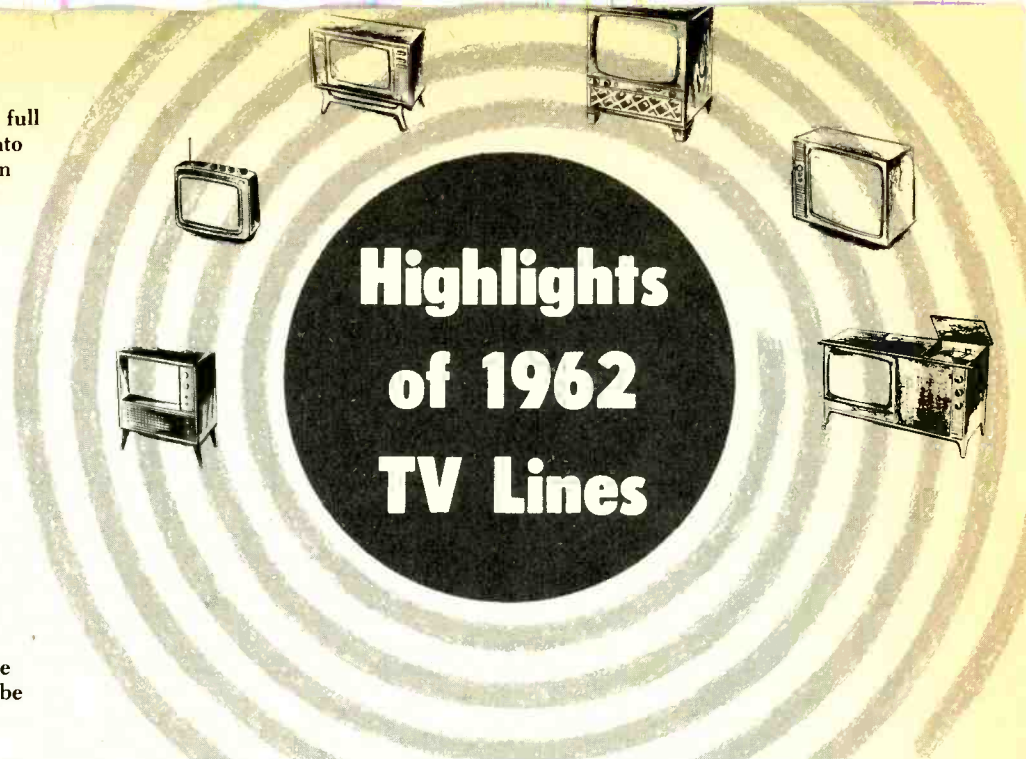

ADMIRAL

Flagship of the '62 fleet is the SP23 *Life Tested* chassis, which appears in several versions (20A8, -B8, and -D8) in nearly all 23" receivers of both the *Imperial* and *Masterpiece* series. Most of these sets use a new 92° picture tube, the 23BTP4, with a bonded and tinted safety shield; however, several models released since the beginning of the season have a similarly-constructed 27" tube. A few "leader" 23" models use a different chassis, the 19B8B, with a nonbonded 92° picture tube. The 19" receivers in the line include a half dozen chassis, divided evenly between *Thinman* portables and *Spectator* compact sets. (Remote-controlled versions of these types are called *Sportsman* and *Viceroy*, respectively.)

Portables have series-string tubes and vertical chassis, but all other black-and-white sets are transformer-powered units with horizontal chassis. Almost identical circuit designs are used throughout the line. The most noticeable new features are high-resistance DC coupling between the video output stage and the CRT—which Admiral calls *Automatic Picture Contrast Restoration*—and the new *Picture Guard* circuit employing a 6K11 or 6Q11 *Compactron* triple triode as a sync separator, AGC keyer, and noise inverter. (A schematic of this circuit appears on page 24 of last month's PF REPORTER.)

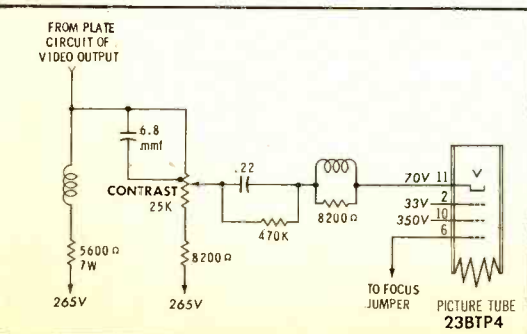

Aside from the *Compactron* and new 'FG7, 'GK5, and 'FQ5 tuner tubes, the only unfamiliar tube is a 6EW7 in the vertical multivibrator and output circuit. This tube has a standard 9-pin miniature base, topped by a glass envelope as big as that of a 6SN7. One reason for this beefed-up vertical sweep tube is the increased high voltage in the SP23 chassis—a maximum of more than 22 kv.

ANDREA

A new 19" compact set was introduced last winter to supplement the basic line of 23" receivers. It uses a VT-119 chassis, which is almost identical to the VT-123 employed with 23" picture tubes. The circuits in both chassis, which are virtually unchanged from those of the previous VS-123 and VR-123 series, include sev-

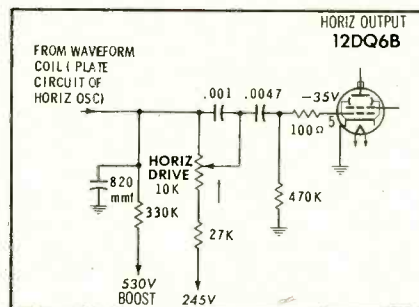

eral unconventional features. For example, the horizontal drive control (see schematic) is a potentiometer in the sawtooth-forming network between the horizontal oscillator and output stages. Also, the input signal for the sync section is obtained from the video detector and fed through a "sync preamp" triode before being applied to the sync separator. In addition, a built-in resistive attenuator pad is provided in the antenna-input circuit as a FRINGE LOCAL adjustment.

CURTIS MATHES

One of the longest horizontal chassis

now on the market has the shortest chassis number: 6. The newest models equipped with this unit, collectively known as the *Super G* series, are the 96-, 106-, 196-, 206-, and 216-23.

In its present form, Chassis 6 differs from the original version in only a few respects. It uses a new 23AHP4 picture tube, the latest type of turret tuner, and a 3DG4 low-voltage rectifier instead of a 5U4GB or 5V3. Also, a 6DE7 dual

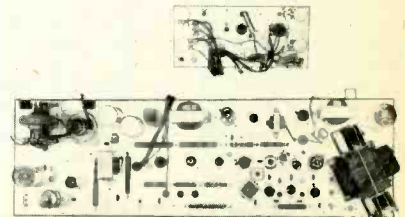

triode has replaced the former combination of a 6C4 and a 6EM5 in the vertical sweep section. However, this circuit is wired as a blocking oscillator and independent output stage, just as before—a configuration seldom seen in the new sets of today.

DU MONT

The 23" and 27" receivers in the new "800" series contain a reworked version of the hand-wired, side-mounted vertical chassis used in previous models. Now in production are the 120612-A (with manual control) and -613A (with remote) for consoles and lowboys, and the 120614-A (manual) and -615A (remote) for *Home Entertainment Center* combinations. The latter units have no audio circuits on the TV chassis, but play through the 40-watt stereo amplifier in the radio-phono section. The 1962 line also contains two 19" sets—a portable and a table model.

A new feature, standard on all full-sized sets, is *Electronic Eye* automatic

CHASSIS NO.	NO. TUBES	PWR XFMR	CRT TYPES	DEG DEF	BOND SHLD	HAFC TYPE	HOSC TYPE	KEY AGC	WIDTH CTRL	MAX KV	WIR-ING	PROTECTED LINE B+	CIRCUITS SWP	FIL	REM AVL
ADMIRAL 16A9, -B9B, -C9, -G9B 16D9, -E9, -F9 19B8B 20A8, -B8, -D8	14 15 16 16	✓ ✓ ✓ ✓	19XP4 19XP4 23AUP4 23BTP4	114 114 92 92	✓	✖ ✖ ✖ ✖	M M M M	✓ ✓ ✓ ✓	sleeve sleeve	15.5 15.5 22 22	P P P P	✓ ✓ ✓ ✓			✓ ✓ ✓ ✓
ANDREA VT-119 VT-123	18 18	✓ ✓	19AFP4 23GP4	114 110	✓ ✓	tube tube	B B	✓ ✓	coil coil	15.5 17	H H		✓ ✓		
CURTIS MATHES 6	18	✓	23AHP4	92		✖	S	✓	sleeve	22	H	✓ ✓		✓ ✓	
DUMONT 120612-A, etc.	17	✓	23YP4; 27VP4	92 (23")		tube	M	✓	pot	20	H	✓	✓ ✓	✓ ✓	✓ ✓
EMERSON 120572-C 120587-A, etc.	16 16	✓ ✓	19XP4 19XP4; 23CP4	114 110 (23")		✖ ✖	M M	✓ ✓	jumper	NA 18	P P	✓ ✓		✓ ✓	✓ ✓
GENERAL ELECTRIC LW MW	16 16	✓ ✓	19ZP4 19BHP4; 23NP4	114 114		✖ ✖	M M		coil, sw coil, sw	16 20	P P	✓ ✓	✓ ✓	✓ ✓	✓ ✓
MAGNAVOX 30 Series 33 Series 34 Series 35 Series 36 Series	20 17 18 16 17	✓ ✓ ✓ ✓ ✓	23MP4; 21CEP4; 24AHP4 21DLP4; 23ASP4; 24AUP4; 27XP4 19YP4; 23MP4 23ASP4; 27XP4 19BTP4; 23MP4	114 110 90 90 114 90 114		✖ ✖ ✖ ✖ ✖	M M M M M	✓ ✓ ✓ ✓ ✓	pot coil coil coil coil	20 20 20 20 20	H H H P P		✓ ✓ ✓ ✓ ✓	✓ ✓ ✓ ✓ ✓	✓ ✓ ✓ ✓ ✓
MOTOROLA TS-440 TS-436 TS-441 TS-448, -50 TS-570 TS-576	16 17 17 17 17 17	✓ ✓ ✓ ✓ ✓ ✓	19XP4 19XP4 19AFP4 19XP4 23AHP4; 23YP4 23MP4	114 114 114 114 92 114		✖ ✖ ✖ ✖ ✖ ✖	S S S S S S	✓ ✓ ✓ ✓ ✓ ✓	pot pot pot pot pot pot	19 19 19 19 23 23	P H H H H H	✓ ✓ ✓ ✓ ✓ ✓		✓ ✓ ✓ ✓ ✓ ✓	✓ ✓ ✓ ✓ ✓ ✓
MUNTZ J Series	12		assorted	asst.		tube	M			NA	H	✓			✓
OLYMPIC LV LLA LB, LC, LE	14 15 16	✓ ✓ ✓	19XP4 23AHP4 23AHP4	114 92 92		✖ ✖ ✖	M M M	✓ ✓ ✓		12 13.5 17	H H H	✓ ✓ ✓		✓ ✓ ✓	
PACKARD-BELL 88-13 Series 98D14, -5, -6	16 18	✓ ✓	19YP4 23MP4; 27VP4	114 114 92		✖ ✖	M M	✓ ✓	coil coil	18 NA	H H	✓ ✓			✓ ✓
PHILCO 12J27 12N50 12N51 12N51A 12N52 12N53, -4	14 16 16 16 16 16	✓ ✓ ✓ ✓ ✓ ✓	17DRP4; 19ABP4 23BVP4 19BLP4 23BNP4 19ABP4 23BNP4	114 92 114 110 114 110	✓ ✓ ✓ ✓ ✓ ✓	✖ ✖ ✖ ✖ ✖ ✖	M M M M M M	✓ ✓ ✓ ✓ ✓ ✓	pot pot pot pot pot pot	18 20 20 20 20 20	P P P P P P	✓ ✓ ✓ ✓ ✓ ✓		✓ ✓ ✓ ✓ ✓ ✓	✓ ✓ ✓ ✓ ✓ ✓

brightness control (ABC). This circuit includes a cadmium sulfide photoconductive cell, mounted on the front panel of the receiver, which responds to changes in room lighting by varying in resistance.

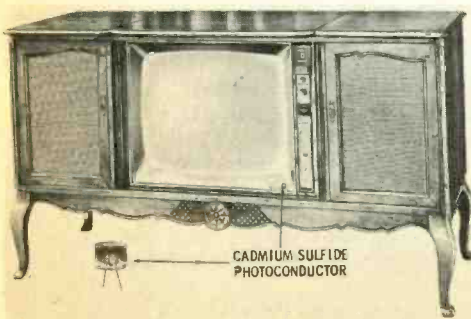

The unit is wired into the video output stage in such a way that it can control the brightness by affecting the grid-cathode bias on the picture tube, and also change the contrast by affecting the screen voltage of the video output stage. An ABC ON-OFF switch can be used to cut the special resistor out of the circuit, restoring normal operation of the conventional brightness and contrast controls.

A redesigned video IF strip uses two 6EH7 tubes and one 6EJ7—internally-shielded, 9-pin, frame-grid pentodes. These tubes provide increased gain in fringe areas, and the 6EH7's have a semiremote cutoff characteristic which enables them to handle very strong input signals and high AGC voltages in metropolitan areas.

A new tube type, the 6HS8, has taken

the place of the 6BU8 in the AGC keying-sync separator-noise inverter circuit. The FRINGE LOCK control formerly used

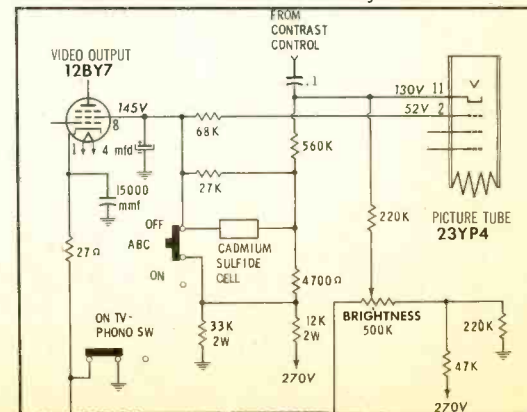

CHASSIS NO.	NO. TUBES	PFM X/FMR	CRT TYPES	DEL DEL	BOND SHLD	HAFC TYPE	HOSC TYPE	KEY AGC	WIDTH CTRL	MAX KV	WIR-ING	PROTECTED LINE	CIRCUITS B+	SWP	FIL	REM AVL
RCA																
KCS 137	16		19AYP4	114		**	B	/	coil	20	P					/
KCS 138	16		19AXP4	114		**	B	/	coil	18	P					/
KCS 136	17	/	23BJP4 23BKP4, 23BLP4	92 92	/	**	B	/	coil	22.5	P	/	/			/
SETCHELL-CARLSON																
C-117	17	/	17DSP4	110	/	**	M	/		15	H	/		/		
C-219	17	/	19BRP4	110	/	**	M	/		15	H	/		/		
362	22	/	19BRP4; 23CP4	110	/	**	M	/		17.5	H	/		/		
X162	22	/	23CP4	110	/	tube	M	/		17.5	H	/		/		
159	22	/	23YP4 27VP4	92 92	/	tube	M	/		18	H	/		/		
SILVERTONE																
.51780 etc.	14		19AXP4; 19AYP4; 23ALP4	114 114		**	M			16	P		/			/
.50420, etc.	14		23AHP4	92		**	M			16	P		/			/
.51800, etc.	15		23AHP4	92		**	M			16	P		/			/
.52400, etc.	15		19AYP4; 23BQP4	114 114	/	**	M	/		20	P		/			/
SYLVANIA																
546 Series	16		19AUP4	114	/	tube	M	/	pot	18	P		/			/
550 Series	16		19XP4	114		tube	M	/	pot	18	P		/			/
			23CP4	110	/								/			/
555 Series	17		23BGP4; 23BHP4	110	/	tube	M	/	pot	19	P		/			/
TRAV-LER																
1180-32	15		19XP4	114		***	M	/		18	H	/				/
1180-12	16		19XP4	114		***	M	/		18	H	/				/
1179-22	17	/	19XP4	114		***	M	/		18	H	/				/
1070-52	17	/	23MP4	114		***	M	/		18	H	/				/
1078-191 (Com.)	26	/	23AHP4	92		***	M	/	sleeve	18	H	/				/
WELLS-GARDNER																
S16	14		19BFP4	92		**	M			16	H		/			/
S14	14		19XP4	114		tube	B			16	H		/			/
S15	14		23AHP4	92		**	B			16	H		/			/
S19, R19	14		23AHP4	92		tube	B			18	H		/			/
N13, N20	17	/	23MP4	114		tube	B	/		20	H		/			/
WESTINGHOUSE																
V-2416 Series	15		19AHP4	114		**	M		sleeve	15	P		/			/
V-2409 Series	16	/	19ACP4	114		**	M		sleeve	15	P	/				/
V-2414 Series	16	/	23FP4A	114		**	M	/	sleeve	16	P	/				/
V-2417 Series	17	/	23FP4A	114		**	M	/	coil	16	P	/				/
ZENITH																
16G20, -H20	16	/	19BDP4	92		**	S	/	sleeve	15-16	H	/	/			/
16G27, -H27	16	/	19AJP4	114		**	S	/	sleeve	18	H	/	/			/
16G21, -H21	16	/	21CXP4	90		**	S	/	sleeve	20	H	/	/			/
16G22, -H22	16	/	23ANP4	92		**	S	/	sleeve	22	H	/	/			/
16G23, -H23	16	/	23ANP4	92	/	**	S	/	sleeve	20	H	/	/			/
16H28	16	/	23AFP4	92	/	**	S	/	sleeve	22	H	/	/			/
17G28	17	/	23AFP4	92	/	**	S	/	sleeve	22	H	/	/			/

NOTE: Some lines include additional chassis carried over from '61—see text. Check marks indicate chassis has certain features. BOND SHLD is bonded safety shield on CRT, and REM AVL means some models are available with remote control. NO. TUBES refers to VHF models; includes CRT. Letter symbols are as follows: HOSC TYPE—M, multivibrator; B, blocking oscillator; S, sine-wave oscillator. WIRING—H, hand; P, printed. ANY COLUMN—NA, data not available.

in this stage has been discontinued, but the AGC DELAY and DUMONITOR controls are still used.

Another innovation in the '62 line is a circuit breaker in the power-transformer primary circuit.

EMERSON

Many of the latest sets are equipped with a vertical, transformer-type chassis descended from last year's 120530-C. The most recently-added chassis numbers are 120587-A, -88B (UHF), and -89-C in 23" sets, and 120593-A in 19" units. This series includes several TV-AM-FM-phono combinations, one with wireless remote control. Lowboy and portable models are also available for remote operation.

The 120587-A and related chassis have

a redesigned video IF strip using high-gain 6GM6 tubes in the first two stages, and some sets have a 6GW6 horizontal output tube instead of the usual 6DQ6B. Also new is a Perm-Lok tuner with a 6GK5 RF amplifier. This unit has no



conventional fine-tuning control, but provides for preset fine tuning adjustments.

A group of 19" combination models uses Chassis 120572-C or -73-D, a revamped version of the two-piece transformerless chassis used in some '61 sets.

GENERAL ELECTRIC

An "early bird" in the '62 line, the 19" *Celebrity* portable using Chassis LW, was introduced last winter. (For details, see *Previews of New Sets*, September, 1961 PF REPORTER.) Since then, a larger MW chassis has appeared, and is being used in most of the new receivers this fall—19" compacts, consoles, and combinations. A few additional models have the deluxe U5 chassis, carried over from '61.

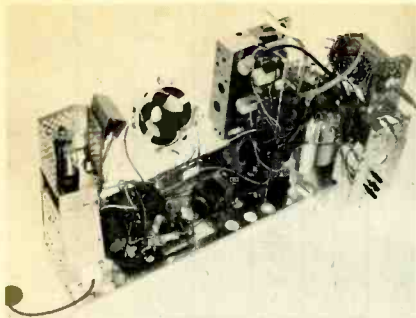

The Hy-Power MW chassis is generally similar to last year's M6; the most notable difference is that a 6DT6 sound detector has been adopted in place of the ratio detector formerly used. Also new are speakers with aluminum voice coils, Daylight Blue CRT's, a 6JC8 mixer-oscillator tube in some tuners, a series-connected video detector, and a 4-kv increase in high voltage to a maximum value of 20 kv.

Among the features being continued from last year are a customer-operated PICTURE WIDTH control (tapped width coil and switch), horizontal retrace blanking, a Picture Tube Guard (spark gap) protecting the CRT accelerating anode, and sonic remote control.

The unmarked, rectangular device on



the front panel of receivers with power tuning is a rocker-button channel selector. When the light-colored area at the bottom is pressed, the tuner advances to the next programmed (active) channel; pushing on the dark area at the top causes the tuner to stop at all channels, programmed or not. The power-tuning system also includes AFT (a preset fine-tuning arrangement).

MAGNAVOX

Ranging from 19" compacts to massive Spectacular Stereo Theater 27" combinations, the present model line-up makes use of five different sizes of picture tubes. Following past custom, the line includes a couple of all-new chassis and several revisions of previous units. Those carried over into '62 are the 30, 33, and 34



series, which account for a variety of models in all styles (including combinations and remote-equipped units). New types of tuners, with the 6GK5 RF amplifier, are used in most of these receivers; in addition, many models have the *Magnalux* automatic brightness-contrast circuit which first appeared this spring. Its key component is a cadmium sulfide cell which varies the resistance of a B+ voltage divider according to the level of room light. This circuit governs the contrast by adjusting the screen voltage of the video amplifier, and simultaneously varies the voltage applied to the brightness control in the grid circuit of the picture tube.

Magnalux is also included in some models of the 35 and 36 series. These are 90° and 110° versions, respectively, of the new printed-circuit chassis which was pictured in July *Previews of New Sets*. This low, U-shaped vertical chassis

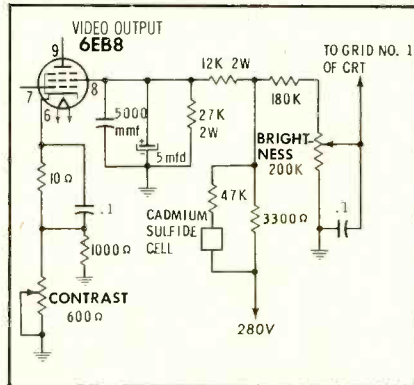

has several features to simplify servicing, including "swing-out" mounting, component symbols stamped on the wiring side of the printed board, and conductor paths marked on the component side. Both chassis use a new 9-pin audio output tube, the 6GC5; in addition, the 36 series has a 6GW6 horizontal output tube.

MOTOROLA

A junior edition of the familiar hand-wired, horizontally-mounted *Golden M* chassis appears in all the new 19" sets, with two exceptions—the *Astronaut* all-transistor portable, and one other portable using a revised version of last year's *PLAcir* printed-circuit chassis. Four series of compact 19" sets are offered (see chart); they differ only in details such as cabinetry, CRT types, tuners, and horizontal AFC systems. The latest 23" chassis (TS-570 and -576) follow the same basic style of construction as in recent years; however, they feature increased high voltage and other refinements.

Most 23" and some 19" models have a new customer control, the PICTURE OPTIMIZER. This is simply a 7000-ohm pot in the video-detector load circuit; its function is to vary the video bandwidth. Another circuit innovation concerns the AFC for the sine-wave horizontal oscillator. The reactance-tube stage has been eliminated, and the frequency is governed by regulating the discharge of an RC network in the oscillator-grid circuit (C1 and R1) with a relatively wide-swinging DC control voltage. Some 19" sets introduced early this year utilize a com-

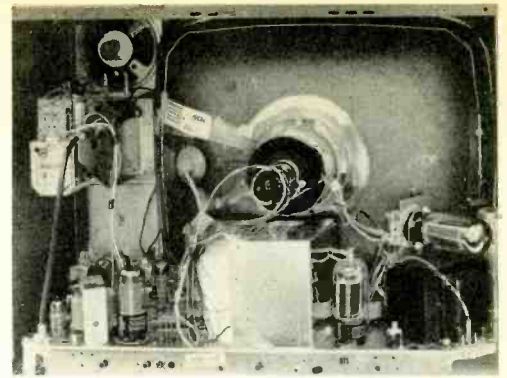

mon-anode dual selenium diode to develop the AFC voltage, but all later chassis use a triode tube for this purpose.

All sets except carryover models have two or three 6BL8 triode-pentodes in the main chassis; the new four-wafer *Golden M Custom-Matic* and other switch tuners

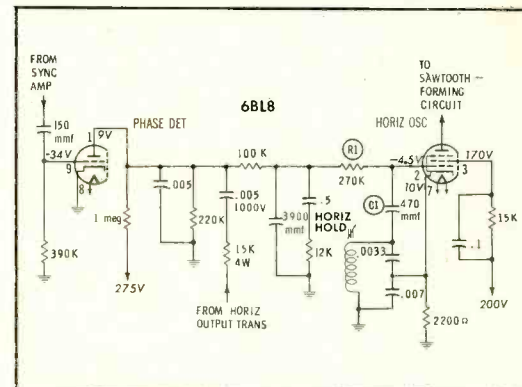

also use this new tube type in the mixer-oscillator stage. Incidentally, most tuners have a 6FY5 frame-grid triode RF amplifier.

Several other new tubes appear as "alternate types" in various chassis. These are similar to, but not interchangeable with, older types employed in the same stages. Alternate pairs are as follows: 6HL8-6BL8 in several applications; 3GS8-3BU8 AGC-sync tubes; 6AL3-6AF3 dampers; 3A3-3AW3 high-voltage rectifiers; and 5DJ4-5U4GB low-voltage rectifiers.

MUNTZ

All present models use the same basic "J" chassis, which obtains its name from its shape—a long, narrow horizontal section with a vertical extension at one side. The actual chassis number varies according to the model. Substantially the same circuitry is used with both 90° and 110° picture tubes. The 23" and 19" sizes of



CRT's are gradually displacing 21" and 17" units, although some of the latter are still in the line.

The latest type of turret tuner is being incorporated in current production. Also, a remote-controlled model—with 2-button, sonic-type transmitter and transistorized receiver — was introduced a few months ago. TV-stereo combination models (with or without radios) are available.

A completely new "metropolitan" chassis is being prepared for introduction in the near future. This unit will contain only 7 tubes, but some of them will be multipurpose *Compactrons*. High-power stages may employ *novar* tubes.

OLYMPIC

Concentrating on 23" combinations, this line boasts a series of *Sound Control Center* units which can independently furnish TV, radio, and phono entertainment



to three different rooms all at once (using auxiliary speaker enclosures). One of the lower-priced models has a simpler arrangement in which either the radio or the phonograph can be played simultaneously with the TV.

There are three different series of 23" models, each including table TV's and consoles as well as combinations. The 100 (leader) series uses the LLA chassis, which has two IF's (a 6BZ6 and a frame-grid 6EJ7) and a triode-type sync separator. The LB and similar chassis in the *High Fidelity 200* series have an additional 6BZ6 IF tube, plus a 6BU8 as a sync separator and AGC keyer. The top-of-the-line *Custom 500* series, featuring Olympic's 3-D *Sound*, uses a chassis basically similar to the LB, equipped with three push-button audio tone selectors. All chassis are transformer-powered units,

physically almost the same as last year's designs.

One 19" portable, also transformer-powered, is included in the '62 line. This model has an automatic timer which can be set to turn the receiver off at any time during a three-hour period.

PACKARD-BELL

Wireless remote control is being offered this year for the first time. Available in both 2- and 4-function types, the new ultrasonic system is called *Roto-Remote* because the transmitter is keyed by means

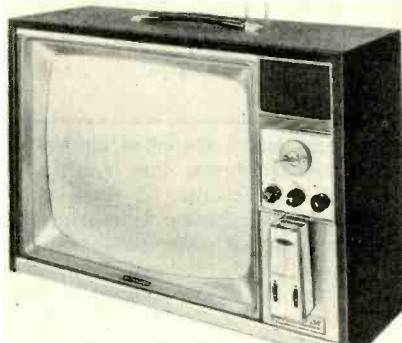

of thumb wheels instead of push buttons.

The latest editions of the *Rangefinder 88* chassis, numbered 88-13C through -F, are used in the *Astronaut* series of 19" sets. These vertical chassis are similar to 88's of past years, except for minor details. Some have a 6GK5 tuner and a 6EW7 vertical sweep tube. Certain models are equipped with a three-hour sleep-switch timer that opens the power-transformer primary circuit to turn the set off; still others have a 2-function remote unit. Various 19" compacts and one 23" table model are designed for mounting on an *Intenna* base—a stylish stand or teacart containing a built-in dipole antenna.

The 23" line-up includes some models with different versions of the 88 chassis, and a new *Award* series of deluxe models using the 98D14, -15, and -16 chassis. Special features of these sets include a two-stage video amplifier, a DC-restorer stage, and a horizontal retrace-blanking amplifier; also, some models offer automatic brightness control. The DC restorer can be disabled by a switch, actuated by pushing in on the brightness-control knob.

At the top of the line, the 98D15 chassis features *Complete Remote Computer Control*, a wired remote system including all major customer controls. (This is not to be confused with the *Computer Dial*, an illuminated channel indicator used in many sets.) Another super-deluxe model is a 27" lowboy console using the 98D14C chassis.

The term *Convertible TV* is applied to many *Award* models, indicating that they have provisions for quick field installation of a wireless remote unit whenever the owner wishes to add this feature.

PHILCO

Although the new "K"-line chassis look much the same as their 1961 counterparts, closer study reveals many interesting innovations. In all sets except "briefcase" portables, both sweep circuits have automatic compensation for the effects of brightness changes. The portables now include *Automatic Picture*

Pilot (keyed AGC), a contrast control in the screen circuit of the video amplifier, and extra-high-gain 4EH7 and 4EJ7 tubes in the two IF stages.

The 12N50 chassis series—a horizontal, transformer-powered *Cool Chassis* design—extends through the whole line-up of 23" and compact 19" models. The 23" sets come in three series: *Super 90* (12N50 chassis) with 90° picture tube; *Deluxe* (12N51A) with 110° CRT; and *Custom* (12N53,-4) with several features aimed at heightening picture and sound quality. As for portables, a single chassis (the 12J27, with 450-ma series-string tubes) serves for both 17" and 19" models.

The tuner in the 12N50 series, one of the few cascode types now in production, has a 6ES8 frame-grid RF amplifier. Portables use a new switch tuner with a 3GK5 neutralized triode. Remote controls are of the *Directa* wireless type, except for the "New-Matic II," squeeze-bulb unit used in some portables.

A *varistor* in the 12N50-series chassis prevents the width and high voltage from fluctuating according to raster brightness.

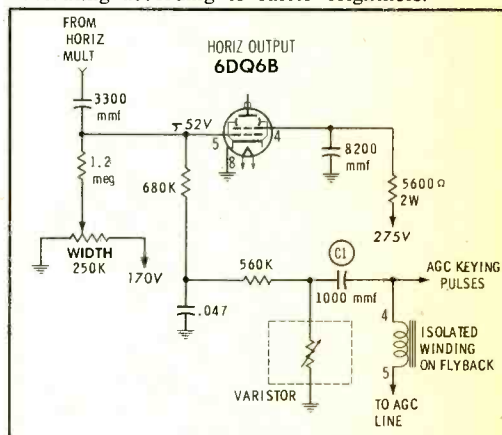

On dim scenes, or when the brightness control is turned down, the decreased load on the HV supply causes an increase in the positive-pulse voltage fed from the horizontal output transformer to the *varistor* (see schematic). Since the resistance of this unit goes down when the voltage across it goes up, it allows the stronger pulses to place a relatively heavy charge on C1. This increases the negative DC voltage at the grid of the horizontal output tube, and thus reduces the input to the flyback system. Conversely, an upward shift in brightness causes an automatic increase in horizontal drive. Notice the unusual width control, which governs the average output-tube bias.

Brightness compensation for the vertical sweep is provided simply by interconnecting the brightness-control circuit and the grid-bias circuit of the vertical output tube.

The *Custom* chassis has a *BLACK LEVEL* control which gives the viewer an option of DC or AC coupling from the video amplifier to the picture tube. (The former yields richer black tones and a truer gray scale, if customer controls are accurately adjusted.) The AC-DC switch circuit also includes compensation for contrast-level variations. Two brightness controls (main and auxiliary)

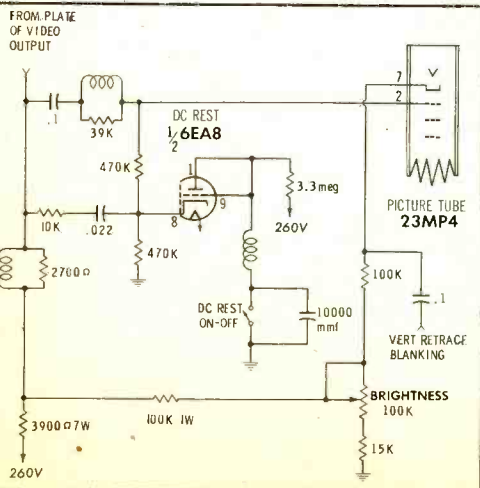

make it possible to obtain correct brightness under all conditions.

Custom sets also feature an unusually high CRT accelerating-grid potential of 650 volts. The video amplifier is a 6HZ8 *Intensi-Tube*—a 9-pin “super-miniature” with 6SN7-sized envelope and 8-watt plate-power rating. Incidentally, all 110° sets (including portables) have a 6- or 13FD7 vertical output tube which is similar to the 6HZ8 in physical appearance.

Other new tube types this year, besides the ones already mentioned, are

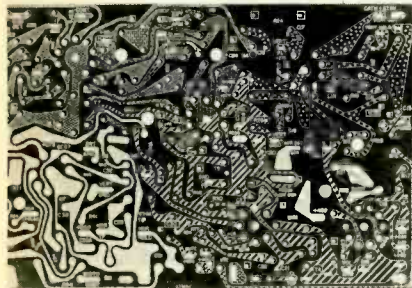

CODE:
PLAIN -- HORIZ SWEEP
POLKA DOTS -- VERT SWEEP
CROSSHATCH -- VIDEO
STRIPES -- AUDIO
"BRICKS" -- SYNC

the 11JE8 audio output-keyed AGC tube in portables, and the 6JE8 used as a video amplifier-sync separator in the 12N50, -1, and -2 chassis.

All sets have *Trace-Coded*, “sectionalized” circuit information. The foil-conductor paths marked on the component side of each printed board are not all solid lines, as before; instead, five different patterns are used to indicate various functional sections of the receiver. A new *TV Trace* booklet, keyed to these markings, is available to provide troubleshooting suggestions.

RCA

Radical changes in physical layout, and an abundance of new tube types, are the most quickly-noticed features of the latest 23” chassis (KCS136) and two new 19” units, the KCS137 and -8. Besides these all-new designs, the '62 lineup includes several carryover models (mostly 17” and 19” sets), using updated versions of last year's KCS130, -2, and -3 chassis. The entire new group of receivers comprise the *New Vista* line, so named because all tuners use a *nuvistor* triode RF amplifier.

Sets containing the *Power Pack* (KCS-138) or *Deluxe Sportabout* (KCS137) chassis are physically larger than “briefcase” types, with a less crowded chassis

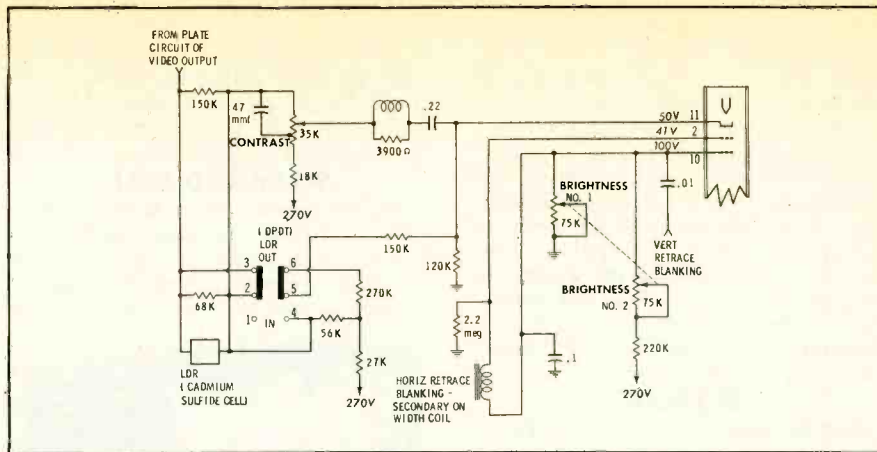
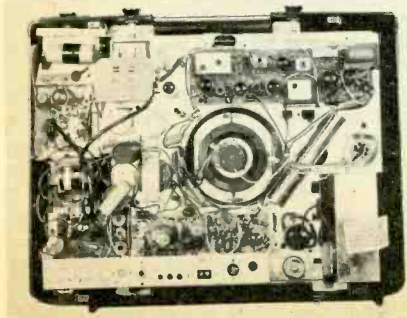

arrangement and a simplified method of disassembly. However, they qualify as true portables because of their lightweight design, featuring a transformerless power supply with polarized line plug. Many of the 450-ma series-string tubes in these sets are completely new: 2CW4 RF amplifier, 5GM6 second video IF, 5EW6 third video IF, 10HF8 video output-sound IF, 6GX6 sound detector (similar to the 6DT6, but with higher output), 6GY6 keyed AGC-noise inverter (also a modified 6DT6), 8FQ7 horizontal oscillator, 17GW6 horizontal output, and 17DM4 damper. The 4BZ6 first IF, 4AV6 sync separator, and 13EM7 vertical output tubes are also somewhat rare types.

The KCS136 *Magic Monitor* chassis, used in most 23” sets this year, is electrically very similar to the new 19” units, but is laid out horizontally as shown in *June Previews of New Sets*. In addition, it is transformer-powered, and uses 6.3-volt versions of the above-listed tubes. The high-voltage rectifier is a 3A3 which produces a maximum output of 22.5 kv. Three different types of 92° picture tubes are used. Two have bonded-shield construction, and one of these is also glare-proofed. Many models include a *Magic Eye* automatic brightness-contrast control (see schematic), which uses a *light-dependent resistor* (cadmium sulfide cell) to vary the resistance in series with the contrast control. This unit also affects the cathode voltage of the CRT, thereby adjusting the brightness. A manual brightness control is also provided. Using two ganged potentiometers, it maintains a constant voltage between the control grid and accelerating grid of the low-Eg2 picture tube. All sets, with or without the *Magic Eye*, have *Automatic Scene Control*—high-resistance DC coupling between the video output stage and the CRT.

The *Automatic Channel Equalizer* (keyed AGC) circuit has been modified to include more extensive noise cancellation, thus dispensing with the separate triode noise inverter used last year. Negative noise spikes are developed in the screen circuit of the AGC tube and fed to the grid of the sync separator to cancel out positive noise pulses at that point. In addition, the negative noise signal is applied to the suppressor grid of the AGC tube to prevent development of excessive AGC bias in noisy areas.

A new remote-control system, with a partially transistorized receiver, is available in both 23” and 19” sets. Also, a UHF tuner with a built-in two-stage IF amplifier is available for field conversion of this year's VHF-only 23” models.

SETCHELL-CARLSON

Many familiar features of past lines have reappeared this year in updated form, and there is a newly expanded series of 19” models including a portable, furniture-styled table TV's and a console. An unusual accessory for the portables is a *Port-a-Voice* stand, which has a built-in 8” speaker in a bass-reflex enclosure.

The *Custom Unit-ized* series of large consoles and combinations is again using Chassis 159, which has seven plug-in TV subassemblies, plus provisions for plugging in an assortment of accessories—stereo amplifiers, FM and AM radios, and

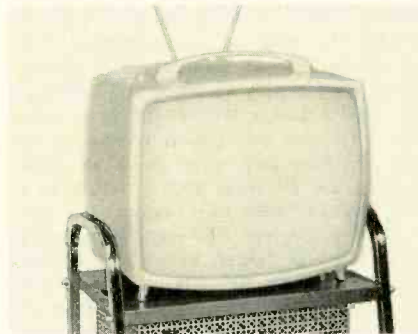

additional speakers. This chassis has been modernized with a new *Adjustomatic* tuner (using a 6GK5 RF stage) and a choice of either 92° or 114° horizontal-sweep units. This chassis is available without a cabinet, for custom built-in installations.

Chassis X162 (available in one console model) also uses the *Unit-ized* TV-circuit sections, but it has no provision for adding accessory components other than an AM radio.

Other “furniture” models this year (both 19” and 23”) use Chassis 362, which is similar to last year's one-piece Chassis 361—except for a new 6GK5 tuner and a redesigned vertical sweep circuit. Setchell-Carlson, long a proponent of separate vertical multivibrator and output stages, has finally adopted a combined circuit using a 6HC8 tube. This

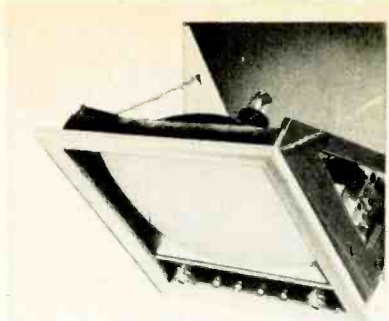

new triode-pentode tube has a 6SN7-sized envelope and a standard 9-pin miniature base.

The new 19" portable has the same curve-side styling as previous 17" models. Its C-219 chassis is somewhat similar to, but yet distinct from, the C-117 used in this year's 17" portable.

SILVERTONE

A type of vertical chassis newly introduced last year, with 450-ma series-string tubes mounted facing the CRT, is extensively used in the '62 models. This chassis pivots outward to give access to

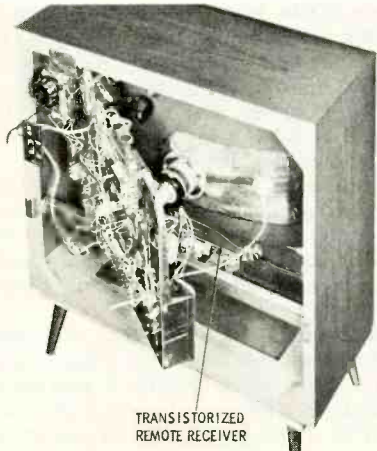

tubes and components on the front side; however, the CRT leads in some models must be unplugged before the chassis can be swung out farther than shown in the photo.

Two basic versions of the "tubes front" chassis are in production. One series, including chassis numbers ending in .51780, .51840, etc., has two video IF's, simple AGC, and a triode-type sync separator. The other series, represented by the .52400 chassis, is used in "step-up" models; it has three IF's, a 4GS8 keyed AGC-sync separator tube (an improvement on the 4BU8), and a horizontal drive control consisting of a variable cathode resistor in the horizontal output stage.



The '62 line-up includes two additional chassis series, both based on older designs with conventional vertical-chassis layout (tubes facing rearward) and 600-ma series-string tubes. The .50420 chassis has two IF's, while the .51800 series has three. Neither series includes keyed AGC.

All of the latest sets are using a new switch or turret tuner with a 2- or 3GK5 RF amplifier; a 10- or 13EM7 vertical sweep tube; and fewer component-combination units than in models of a few years ago.

SYLVANIA

This season marks the most far-reaching change in this manufacturer's chassis design in over four years. A transformer-powered *GT-555* chassis with a spacious horizontal layout has been introduced in the *Picture Computer TV* line, which covers most 23" models. (This chassis is also beginning to appear in 19" sets.) The *Flexi-Core* power transformer has several new features, such as welded construction and *Mylar* insulation between layers, to reduce size and weight. The tuner, yoke,

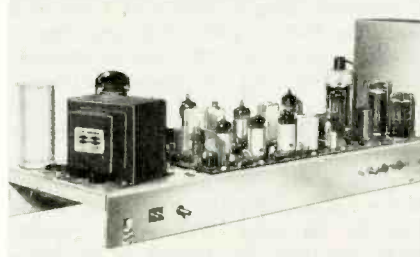

and other subassemblies plug into the main chassis. One large printed board, spanning the middle of the chassis, contains all but the sweep-output and power supply circuits. Simplified wiring paths are indicated on top of the board in a 5-way color code: Red for B+, dashed red and white for plates, green for signal grids, solid white for ground, and dashed green and white for all others. In addition, tube sockets are surrounded with code letters (P. GIT, etc.) to designate elements. The circuits are virtually unchanged from 1961 designs, except that the series-string tubes have been replaced with their 6.3-volt counterparts. This has led to the introduction of one new type, a 6ET7, for the video output and horizontal AFC circuits. One important change is the adoption of a 6EM7 vertical sweep tube to supersede last year's 10EG7.

The bulk of the 19" sets and a few 23's continue to use the transformerless *S-110* chassis in its most recent versions (546 and 550 series). Also, the *dualette*

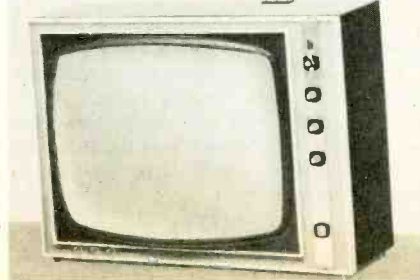

17" portable, using Chassis 543, is still available this year.

All 19" and 23" sets have a horizontal linearity coil, which forms part of a pi-type filter in the plate circuit of the damper.

TRAV-LER

The units shown in the chart are representative samples of a large group of newly-introduced chassis. They differ from older chassis in having a new switch-type tuner with a 6GK5; also, the series-string portables now feature a cir-

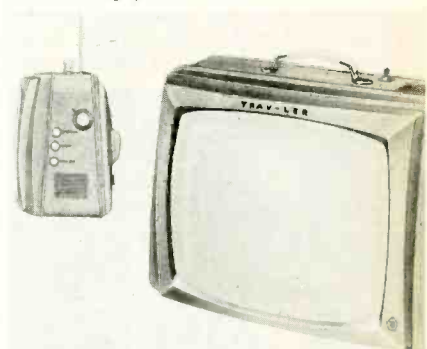

cuit breaker protecting the B+ supply.

To supplement the types shown in the chart, many chassis have been carried over from the '61 season—particularly those used in 23" consoles and combinations. A 19" set with wireless remote control appeared as a late 1961 model, and is scheduled to be included in the '62 line as well.

All the latest chassis are using a 'BU8 AGC keyer-sync separator-noise limiter tube. Most receivers of all sizes employ

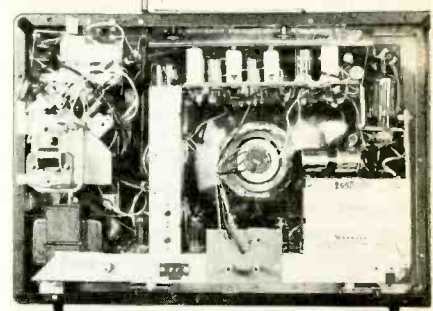

the lightweight double-deck chassis shown in the photo, although some larger models use a wide, horizontally-mounted single-deck unit.

Some chassis are used in *Trav-Ler* branded sets, while other similar units are marketed under a variety of private-label brand names.

WELLS-GARDNER

A wide variety of chassis types appear in sets bearing several different private labels; a cross-section of the latest series are listed in the chart.

Most 19" receivers have a simplified transformerless design, with two video IF's and no sound IF stage. Some use 92" picture tubes, a vertically-mounted chassis. 3BZ6 IF tubes, and a 135-volt B+ supply; others are 114" sets with a horizontal chassis, higher-gain 3DK6 tubes in both IF stages, and 250-volt B+.

The S15 and related chassis are side-mounted vertical units. They are electrically the simplest of all 23" types, with circuitry similar to the 19", 92" series. All other 23" sets have some form of the long, narrow horizontal chassis that has recently characterized the Wells-Gardner line. Many of these are "S" series like the S19, with a 92° CRT; the newest versions have two 3DK6 video IF's and a dual-triode sync circuit. Others are 114° "N"-series units, mostly equipped with extra features such as a two-stage video amplifier (following a three-stage IF), and a 6BU8 AGC keying-sync separator-noise limiter tube.

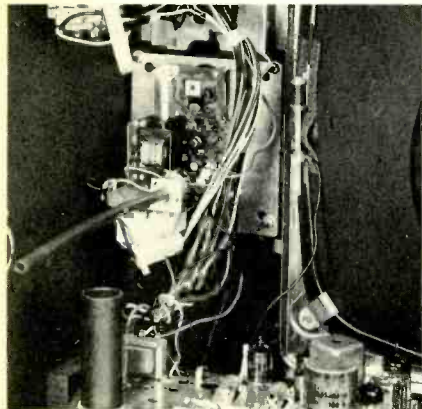

All "N" chassis, and phono-combination models in the "S" series, are transformer-powered. Wireless remote control is available in both lines.

In line with a general trend now occurring in the industry, the CRT anode voltage in many new models is 2 (or more) kv higher than in comparable models of the '61 line.

WESTINGHOUSE

Imaginative new features are plentiful in the '62 sets. For instance, portables using Chassis V-2416-7 and -9 have an *Instant-On* circuit which keeps the filaments operating at half power while the set is turned off. A semiconductor diode, connected into the 450-ma filament string, passes alternate half cycles of line voltage. When the set is turned on, a dual switch shorts across the diode and completes the B+ input circuit, producing immediate operation. By the way, this and other sets in the new V-2416 series closely resemble the earlier V-2384.

Compact 19" *Trendsetter* and *Decorator* receivers are equipped with Chassis V-2409 (a carryover from '61), which is like the V-2416 except for having a transformer-type power supply. The 2-button *Remote Director* wireless remote control used in some of these sets is a new design, with a mechanically-operated transmitter and an all-transistor receiver. *Mobil-Sound*, offered in the V-2409-8 version of this chassis, enables any AM broadcast radio to pick up the TV "sound track" for quiet listening or convenient "chairside" volume adjustment. The AM signal is the output of a miniature transistorized oscillator inside the TV cabinet, modulated by the TV audio. The wireless remote control can turn the *Mobil-Sound* broadcast feature on and off as part of the



volume-stepper switch function.

Certain *Trendsetter* models are concealed inside *Curio Chest* cabinets with folding doors, available in four different furniture styles. Remember this feature if you ever walk into a customer's home and can't find the TV set!

In the 23" division, a few "leader" models use the transformerless V-2414 chassis, a unit comparable to the V-2376 which appeared in the '60 line. Remote-equipped sets have either of two transformer-type chassis continued from last year—the V-2411 with a 2-button remote system, and the V-2389 with a 4-button system. Remaining 23" models, all manually tuned, use the V-2417—a revision of the V-2411. The most newsworthy feature of this latest chassis is a combination width and horizontal linearity coil in series with the horizontal windings of the yoke. The width section simply modifies the strength of the yoke current according to the slug setting. On the other hand, the linearity section uses a permanent magnet to produce a non-linear effect on the current passing through it. The interaction between the field of the magnet and that of the coil can be varied by turning the linearity slug; in this manner, the unit can compensate for nonlinear-sweep problems such as stretching of the left side of the raster.

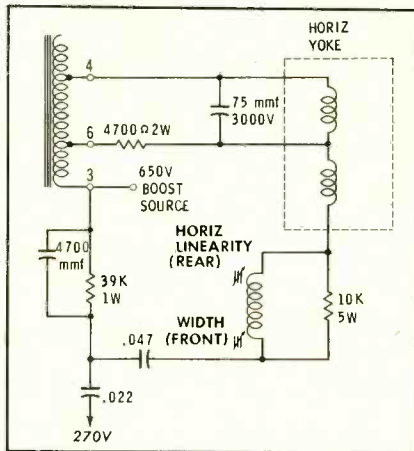

The V-2417 also utilizes a new method of obtaining AGC keying pulses. A 5" length of cable with two conductors (one connected to the flyback and the other to the keying-tube plate) functions as a coupling capacitor.

ZENITH

Gradual change is the keynote here; the new chassis are very similar to the

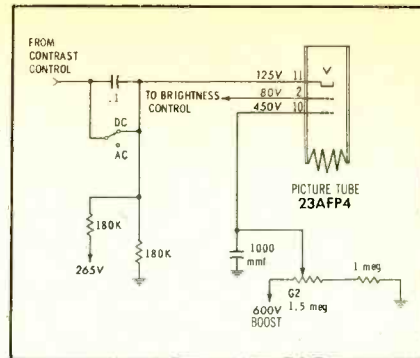

'61 types, and also display only minor differences among themselves. The most important variations are listed in the chart. Corresponding chassis types from the G (spring) and H (fall) series are paired together in these listings, since the two groups are nearly identical. However, there have been a few changes in technical features this fall: for example, all 23" sets in the H series are using three high-gain, frame-grid tubes in the IF strip (two 6EH7's and a 6EJ7).

All chassis except the -20 group now use a 3DG4 low-voltage rectifier and a 6GN8 video output-sound IF tube. In the latter application, the 16G20 has a 6AW8, and the 16H20 introduces a new 6DX8. Another new tube type in the 16H20 is a 6BL8 in the sine-wave horizontal oscillator circuit.

Differences between the -22 and -23 versions of the 23" sets center around the higher CRT-anode voltage of the -22, which requires the use of higher-rated components such as 6CQ4 or 6DE4 dampers.

A number of high-end sets are equipped with the new *Gold Video Guard* turret tuner, which features a gold-platinum-silver alloy on all contact surfaces, a 6FY5 frame-grid triode RF amplifier, and preset fine tuning. Conventional bandswitch and *Target* turret tuners are also installed in many models.

The deluxe 17G28 chassis, introduced last spring, has an extra 6AL5 dual diode which operates as a DC restorer and horizontal blanking clamper. (The second section provides a shunt to ground for any positive voltage fed to the CRT control grid from the blanking circuit.) This feature has been dropped from the fall line; the new deluxe 16H28 chassis has, in its place, a simple AC-DC switch that gives the viewer a choice of direct or capacitive coupling from the video output stage to the picture tube. Since DC coupling requires fairly precise adjustment of the brightness control to set up the correct black level in the picture, the AC position of the switch is recommended for viewers who prefer ease of adjustment to more accurate gray-scale reproduction.

The deluxe chassis also has a PEAK PICTURE control (variable video detector load resistor) and a G2 potentiometer for adjusting the accelerating-anode voltage on the CRT to the optimum value of 450 volts. No other sets in this line have this feature, since they use low Eg2 picture tubes with less than 100 volts on the accelerating anode. ▲



Average \$2.85 more profit on every 21" tube

Turn the page to find out how...



Average \$2.85 more profit on every 21" tube

Sell the Admiral Ensign—the top-quality picture tubes with the biggest profit margin in the industry!

Now Admiral's vast purchasing power and national distribution give you the *one* picture tube line with everything: Finest quality workmanship and performance, backed by a 1-Year Guarantee . . . famous brand-name acceptance . . . list prices that appeal to your most economy-minded

customers...peak dependability.

And you pocket an average of \$2.85 *more profit* on a 21" Admiral Ensign than on other brands. (Comparably higher margin on all other tube sizes.)

Get the facts! Compare the Ensign line with your present replacement tubes. Compare quality, performance, prices and profits! Discover for yourself why dollar-wise servicemen are switching to the Admiral Ensign.

Call your nearby Admiral Distributor! Start earning more now!

Arizona

Arizona Hardware Co.
P. O. Box 2110
Phoenix, Arizona
ALpine 8-5331

Arkansas

Orgill Bros. Arkansas Co.
301 Rector Street
Little Rock, Arkansas
FRanklin 2-5292

California

Don Anderson, Inc.
2500 California
Fresno 21, Calif.
AM 6-0401

Admiral Sales Corporation
P. O. Box 2092—Terminal Annex
Los Angeles 54, California
RAYmond 3-6451

Admiral Sales Corporation
P. O. Box 1270
San Diego, California
BElmont 9-0231

Admiral Sales Corporation
495 Beach Street
San Francisco 11, Calif.
TUxedo 5-6000

Colorado

Griffin Distributing Co.
1140 West 5th Avenue
Denver 4, Colorado
KEystone 4-6274

Louisiana

Orgill Brothers Louisiana Co.
1571 Texas Avenue
Shreveport, Louisiana
Phone: 425-4271

Montana

The Treasure State Gas &
Electric Co.
827 South Montana Street
P. O. Box 866
Butte, Montana
Phone: 2-2400

Nevada

Osborne & Dermody, Inc.
500 Evans Avenue
Reno, Nevada
FAirview 2-6957

New Mexico

Cunningham Distributing, Inc.
615 Haines, N.W.
Albuquerque, New Mexico
Phone: 7-8838

Oklahoma

Appliance Distributors, Inc.
700 North Pennsylvania
Oklahoma City, Okla.
CEntral 6-8308

Oregon

Seaport Appliance, Inc.
3055 N. W. Yeon Avenue
Portland 10, Oregon
CApital 6-6595

Texas

Price Supply Co.
P. O. Box 86
Amarillo, Texas
DRake 2-6730

Lone Star Wholesalers
8000 Ambassador Row
Dallas, Texas
FLetwood 7-1885

Cunningham Distributing, Inc.
2225 Mills Street
El Paso, Texas
Phone: KE 2-6994

Covington Distributing Corp.
34 North Hamilton St.
Houston 2, Texas
CApital 2-0326

Price Supply Company

3104 Avenue A
P. O. Box 1601
Lubbock, Texas
SHerwood 4-1431
Covington Distributing Corp.
P. O. Box 906
San Antonio 6, Texas
CApital 7-7547

Utah

Westward Distributors, Inc.
204 W. Fourth South
Salt Lake City, Utah
ELgin 5-7556

Washington

John E. Amberg Co.
757 Harrison Street
Seattle 9, Washington
MUtual 2-5566

John E. Amberg Co.
N. 210 Ralph Street
Spokane, Washington
KEystone 5-1794

NOTICE: All materials and parts used in the manufacturing of Admiral Ensign tubes are new, except for the envelope, which prior to re-use, was carefully inspected to meet the standards of the original new envelope.

ADMIRAL ENSIGN Picture Tubes

Tarzian offers

FAST, DEPENDABLE TUNER REPAIR SERVICE

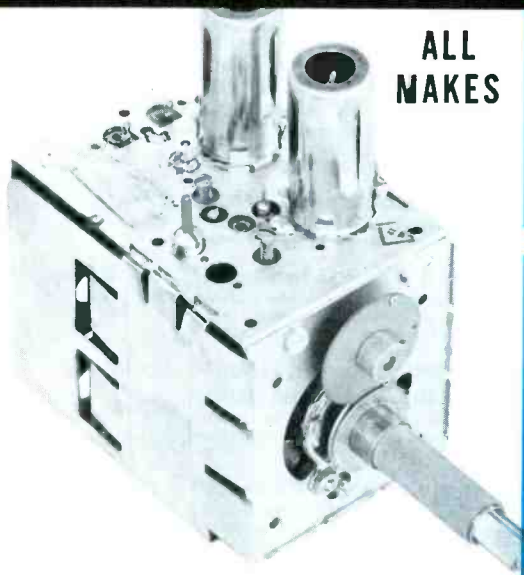

ALL
MAKES

ONLY
\$850
INCLUDING

**ALL PARTS
and LABOR**

**24-HOUR SERVICE
6-MONTH WARRANTY**

**Tuners Repaired on
Approved, Open Accounts**

**See your distributor, or
use this address for fast,
factory repair service**

It just makes sense that a manufacturer of tuners should be better-qualified, better-equipped to offer the most dependable tuner repair and overhaul service.

Sarkes Tarzian, Inc., pioneer in the tuner business, maintains a complete, well-equipped Factory Service Dept.—assisted by Engineering personnel—and staffed by specialized technicians who handle **ONLY** tuner repairs . . . on **ALL** makes and models.

Tarzian-made tuners received one day will be fixed and shipped out the next. Cost is only \$8.50 and \$15 for UV combinations. That includes **ALL** parts and labor, and a 6-month guarantee against defective workmanship and parts failure due to normal usage. Replacements available at low cost on tuners beyond practical repair.

Ⓢ Tarzian-made tuners are identified by this stamping. When inquiring about service on other tuners, always give tube complement . . . shaft length . . . filament . . . voltage . . . series or shunt heater . . . IF frequency . . . chassis identification. All tuners repaired on approved, open accounts. Check with your local distributor for Sarkes Tarzian replacement tuners, replacement parts, or repair service.

SERVICE MANAGER • TUNER DIVISION • DEPT. 3A



SARKES TARZIAN INC

*east hillside drive • bloomington, indiana
edison 2-7251*

MANUFACTURERS OF TUNERS . . . SEMICONDUCTORS . . . AIR TRIMMERS . . . FM RADIOS . . . AM-FM RADIOS . . . AUDIO TAPE . . . BROADCAST EQUIPMENT and SHISH-KABOB GRILLES

publisher
Howard W. Sams

general manager
Mal Parks, Jr.

editor
Vern M. Ray

managing editor
Joe A. Groves

associate editors
Leslie D. Deane
Thomas A. Lesh

consulting editors
William E. Burke
Robert E. Dunham
George B. Monn
C. P. Cliphant
Paul C. Smith

art director
Don W. Bradley

advertising & editorial assistants
Georgeanna Caldwell
Paula Haffner
Jean Sekulski

production manager
Robert N. Rippey

circulation fulfillment
Pat Tidd, Mgr.
Constance McCawley, Ass't.
Katherine Smith, Ass't.

photography
Robert W. Reed

advertising sales offices
midwestern

John Groce, advertising sales manager
PF REPORTER
2201 East 46th Street, Indianapolis 6, Ind.
Clifford 3-6441

eastern

Charles Horner
Howard W. Sams & Co., Inc.
3 West 57th Street,
New York, N. Y.
Murray Hill 8-6350

western

The Maurice A. Kimball Co., Inc.
2550 Beverly Blvd., Los Angeles 57, Calif.
Dunkirk 8-6178; and 681 Market Street,
San Francisco 5, Calif. Exbrook 2-3365

Address all correspondence to
PF REPORTER, 2201 East 46th Street,
Indianapolis 6, Indiana



Copyright © 1961 by Howard W. Sams & Co., Inc. PF REPORTER is a trademark of Howard W. Sams & Co., Inc. No part of PF REPORTER may be reproduced without written permission. No patent liability is assumed with respect to use of information herein. Acceptance of advertising does not in any manner signify the products, policies and services so advertised have been approved, endorsed or recommended by this magazine.

Indexed in *Electronic Guide* and *Lectrodex*.
Printed by the Waldemar Press Div.
of Howard W. Sams & Co., Inc.



PF REPORTER

including **Electronic Servicing**

VOLUME 11, No. 10

CONTENTS

OCTOBER, 1961

Highlights of 1962 TV Lines	Thomas A. Lesh	1
A special eight-page summary of important technical features and design trends in the newest sets.		
Letters to the Editor		18
Blast Those TV Intermittents!	Jack Darr	26
Wait—don't resort to dynamite until you've read this article.		
Stock Guide for TV Tubes		28
Painless TV Alignment	Allan F. Kinckiner	32
Shop Talk—Practical ideas for spotting misaligned sets, analyzing response curves, and simplifying alignment setups.		
Planning Intercom Installations		34
Five typical hook-ups you'll find useful as models for many different kinds of systems.		
Schoolroom TV Takes to the Air	Jack Beever	36
A new service challenge in the Midwest: Installing educational TV systems which translate signals from a "flying transmitter."		
Phono Cartridge and Needle Replacement Guide	Les Deane	38
Audio Facts—A coverage aimed at reducing your problems of selecting, stacking, and installing phono-pickup components.		
Smoothing Out the "Piecrust"		40
Quicker Servicing—Check your ability to recognize the symptoms and causes of this horizontal-circuit trouble.		
Service Vehicles—Buy or Lease?	Joe A. Groves	44
Dollar and Sense Servicing—Pros and cons of leasing a truck, plus a look at some '62 models.		
Electronic Control of Lighting	Edward Bukstein	50
Servicing Industrial Electronics—Circuit details of light-dimming controls and photoelectric on-off switches.		
The Electronic Scanner		56
Notes on Test Equipment		58
Lab reports on the EICO Model 260 AC Volt-Watt Meter, Paco Model B12 Bench Power Supply, and Triplett Model 850 VTVM.		
Service Dealer Advertising Program		66
Number 10 in a series.		
The Troubleshooter		72
Product Report		93
Free Catalog and Literature Service		96
Monthly Index	on free literature card	

ABOUT THE COVER

Once again, the TV industry has brought out an array of new models for the fall and winter season. To familiarize you with the latest developments in TV design, this issue leads off with an eight-page special section packed full of facts about all the newly-introduced lines.



Two outstanding products by the HIDDEN

500*

who plan for your future:



DIFILM[®] BLACK BEAUTY[®] CAPACITORS

molded tubular



DIFILM[®] ORANGE DROP[®] CAPACITORS

dipped tubular

TWO GREAT TUBULARS . . . TAKE YOUR CHOICE!

(± 10% Capacitance Tolerance is standard at no extra cost)

- Sprague Difilm Capacitors can't be beat! Dual-dielectric construction combines the best features of both Mylar[®] polyester film and special capacitor tissue. And for additional reliability, Difilm capacitors are impregnated with Sprague's HCX[®], a solid impregnant which produces a rock-hard capacitor section—there's no wax to drip, no oil to leak!
- **BLACK BEAUTY Molded Tubulars** are actually low-cost versions of the famous Sprague high-reliability capacitors used in modern military missiles. They're engineered to withstand 105°C (221°F) temperatures . . . even in the most humid climates! And their tough, molded phenolic cases can't be damaged in handling or soldering.
- **ORANGE DROP Dipped Tubulars** are the perfect replacement for radial-lead capacitors now used by leading manufacturers of TV sets. Leads are crimped for neat mounting on printed wiring boards. Extremely small in size, they'll fit anywhere, work anywhere. And they're double-dipped in epoxy resin for extra protection against moisture.

*The "Hidden 500" are Sprague's 500 experienced researchers who staff the **largest research organization in the electronic component industry** and who back up the efforts of some 7,000 Sprague employees working in 14 manufacturing operations—four at North Adams, Mass.; Bennington and Barre, Vt.; Concord and Nashua, N. H.; Lansing, N. C.; Grafton, Wis.; Visalia, Calif.; two at Ponce, Puerto Rico; and Milan, Italy.

Get your copy of Catalog C-614 from any Sprague distributor, or write Sprague Products Co., 105 Marshall St., North Adams, Massachusetts.



WORLD'S LARGEST CAPACITOR MANUFACTURER



For window size blow-ups of this message, send 10¢ to Sprague to cover handling and mailing costs.

It takes MORE than TOOLS to be a TV Technician!

Just what IS the difference between the "screwdriver mechanic" and the expert TV-Radio Technician?

NOT expensive tools and test equipment—although they ARE essential.

TRAINING is the first big difference. The tinkerer guesses, but the expert technician KNOWS—because he spent years in the study of electronic theory and its application to television techniques.

EXPERIENCE is the next big difference. The professional TV specialist has repaired hundreds—perhaps thousands—of sets. He knows the complexities and the variations in circuits. He is familiar with the hundreds of parts which make up the "innards" of each type of TV. He can diagnose trouble and cure it quickly and safely.

PROGRESSIVENESS is another big difference. The expert TV Technician continually spends countless hours and hundreds of dollars on manuals, keeping up to date on new developments, new circuits, and new troubleshooting techniques. When trouble develops, he knows what to do about it.

Well-meaning, but poorly informed "screwdriver mechanics" and "do-it-yourself-ers," frequently unable to accurately diagnose TV trouble, often "butcher" a set to the point where it can be dangerous as well as expensive.

DON'T RISK YOUR SAFETY OR NEEDLESS EXTRA EXPENSE—CALL AN EXPERT TECHNICIAN AT THE FIRST SIGN OF TROUBLE! HIS FEE IS YOUR INVESTMENT IN SAFETY AND SATISFACTION.

**THIS MESSAGE WAS PREPARED BY SPRAGUE PRODUCTS COMPANY,
DISTRIBUTORS' SUPPLY SUBSIDIARY OF SPRAGUE ELECTRIC COMPANY, NORTH ADAMS, MASSACHUSETTS FOR . . .**

YOUR NEIGHBORHOOD TV-RADIO TECHNICIAN

NOW! GRANTHAM SCHOOLS OFFER FIVE DYNAMIC COURSES

F.C.C. LICENSE PREPARATION

WHAT'S IN YOUR FUTURE?

Are you *planning* your future or just drifting into it? Now is the time to get an F.C.C. license. Now is the time to prepare for higher pay — make your future secure.

F.C.C. LICENSE—THE KEY TO BETTER JOBS

An F.C.C. *commercial* license is your ticket to higher pay and more interesting employment. This license is Federal Government evidence of your qualifications in electronics.

GRANTHAM TRAINING PREPARES YOU

Grantham School of Electronics specializes in quality training in communications electronics, preparing students to pass F.C.C. license examinations.

The Grantham Communications Course teaches you to understand electronic theory — teaches you the "why" of electronics.

If you already have practical experience in radio-electronics, the Grantham course can add a knowledge of theory and an F.C.C. license to that practical experience. This should qualify you for higher pay and greater job security.

This course can prepare you *quickly* to pass F.C.C. examinations because it presents the necessary principles of electronics in a simple "easy-to-grasp" manner. Each new idea is tied in with familiar ideas. Each new principle is presented first in simple, everyday language. Then after you understand the "what and why" of a certain principle, you are taught the technical language associated with that principle. You learn more electronics in less time, because we make theory easy and interesting. *NOTE: All necessary math is included in the course.*

INDUSTRIAL ELECTRONICS

TECHNICIANS NEEDED

Today, the need for industrial technicians is greater than ever. There is a particularly great need for technicians who are trained in electronics.

To meet this need, Grantham Schools now offer a complete course in electronics technology. When you graduate from this course, you will be qualified as an Industrial Electronics Technician—you will have a good background of theoretical knowledge and laboratory training.

COURSE DEVELOPED FOR INDUSTRY

As a student of this course you will study subjects that have been prescribed by selected industrial people, who assisted Grantham Schools in developing this course. You will gain knowledge of industrial equipment through a planned program of theory and lab work. You will work on actual industrial control equipment!

ADVANCED ELECTRONICS COURSE

This is an advanced industrial electronics course. This course will qualify you for electronics employment in such fields as aeronautics, computers, industrial controls, manufacturing, microwave, communications, and others. Entrance requirements include basic math, and basic electronics. You may qualify for entrance by successfully passing our entrance examination. (Note: Successful completion of the Grantham F.C.C. License Course qualifies you for entrance without examination.) Write for details.

INSTRUMENTATION

Following completion of the Grantham Industrial Electronics course you will also be qualified for entrance into the Grantham course in Industrial Instrumentation. Write for details.

PRE-ENGINEERING MATHEMATICS

ARE YOU WEAK IN MATH?

Here is a course which provides all the necessary mathematical background for practically any technical course of instruction one may desire to take. It is designed specifically to qualify you for the Grantham course in Engineering Analysis. Starts out with simple arithmetic—covers logarithms, slide rule, algebra, geometry and trigonometry.

COLLEGE LEVEL? HIGH SCHOOL LEVEL?

This is definitely a pre-engineering math course. It starts at the high school level. There are only three requirements: Intelligence, an inquiring mind, and the desire to improve yourself as a professional man.

If you are a high school graduate, you should be able to commence smoothly with Lesson 1 and advance easily through the 15 lessons which comprise this course. While doing this, you will gain new insight into familiar subjects and find yourself picking up new ideas as you go.

ENGINEERING ANALYSIS

A MODERN ENGINEERING COURSE

Engineering Analysis represents a space-age approach to technical education. It presents the entire field of *analysis* in a unified and practical manner. All the mathematics, graphics, applied mechanics and dynamic system analysis that the engineer needs to engage in the exacting and demanding work of our advancing technology are included.

A high school diploma or equivalent, plus completion of the Grantham Pre-Engineering Mathematics course, is required for entrance into this section of the Grantham Engineering Series.

Write for details on this modern approach to technical education.

Grantham Schools

LOS ANGELES

KANSAS CITY

SEATTLE

WASHINGTON

FOUR RESIDENT SCHOOLS

To better serve our many students throughout the entire country, Grantham School of Electronics maintains four Divisions — located in Los Angeles, California; Kansas City, Mo.; Seattle, Wash.; and Washington, D.C. Grantham offers rapid courses in F.C.C. license preparation.

CORRESPONDENCE OR RESIDENCE CLASSES

Grantham training is available by correspondence or in resident classes. Either way, you are trained quickly and well. Write, or mail the coupon for details on the course you select.

The now famous Grantham Guarantee protects your investment. When such "insurance" is available at no extra cost, why accept less?

ACCREDITED BY THE NATIONAL HOME STUDY COUNCIL

MAIL COUPON FOR LITERATURE

TO: GRANTHAM SCHOOLS, INC.

NATIONAL HEADQUARTERS OFFICE

1505 N. Western Ave., Hollywood 27, Calif.

19-R

Please send me full details on the course indicated below. I understand that there is no obligation and no salesman will call.

NAME _____ AGE _____

ADDRESS _____

CITY _____ STATE _____

Send details on:

F.C.C. License

Industrial Electronics

Instrumentation

Engineering Math

Engineering Analysis

I am interested in: Home Study Resident Classes

Why the WINEGARD ELECTRONIC MOST EFFECTIVE TV ANTENNA...

**DESIGNED TOGETHER
TO WORK TOGETHER... WINEGARD
POWERTRON ANTENNA AND
BUILT-IN AMPLIFIER!**

TRANSISTORIZED!

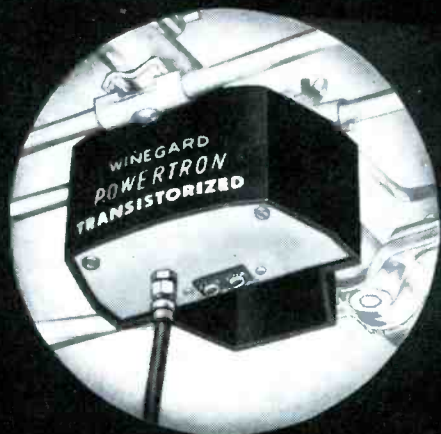

MODEL SP-55X

"By FAR world's most powerful all-channel antenna"

WHY? BECAUSE . . .



IT CAPTURES MORE SIGNAL than any other all-channel antenna ever made. Patented design, electro-lens director system, dual "TAPERED T" driven elements, 30 precision-tuned elements in all.



IT'S THE ONLY TRUE ELECTRONIC ANTENNA. Only the Winegard Powertron is built with the amplifier as part of the driven element—not an "add-on" attachment.



IT ELIMINATES ALL SIGNAL LOSS that normally occurs between the driven element and the amplifier due to transmission and coupling mis-match.



IT BOOSTS WEAK SIGNALS UP OUT OF THE SNOW far better than any other antenna or antenna-amplifier combination made.



FOR VIVID COLOR, HIGH DEFINITION BLACK AND WHITE AND LONG DISTANCE RECEPTION, nothing can compare to the Super Powertron. Thousands have been installed all over the country and our files are full of testimonials from grateful TV viewers and Service-Technicians alike.



WINEGARD IS THE ONLY MANUFACTURER THAT MAKES BOTH ANTENNAS AND RF AMPLIFIERS. Because of this you can feel confident of getting the very best. But don't take our word for it—let your eyes and ears and field strength meter tell the story.



MODEL P-55
Powertron — transistorized, 14 elements.



MODEL P-55X
Powertron with Pack — Transistorized, 21 elements.



MODEL SP-55X
Super Powertron — transistorized, 30 elements.

POWERTRON is by far WORLD'S

Not 60%...Not 70%...but over 95% efficient

OUTFEATURES — OUTPERFORMS ORDINARY ANTENNAS WITH "ADD-ON" TYPE SIGNAL BOOSTERS!

THIS IS BETTER —

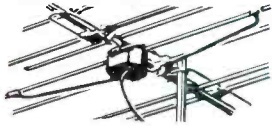

Exclusive amplified "Tapered T" driven element for perfect match and lowest possible signal-to-noise ratio. Only Powertron has it.

THAN THIS —

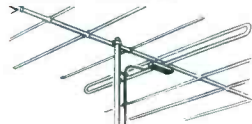

Not an after-thought "add on" signal booster hung on an ordinary antenna — not an old fashioned mast mounted booster.



ONLY POWERTRON HAS BOTH 300 OHM TWIN LEAD OR 75 OHM COAX TERMINALS ON BUILT-IN AMPLIFIER.



ONLY POWERTRON GIVES YOU YOUR CHOICE OF TRANSISTORS OR TUBES (TUBE MODELS 300 OHM ONLY).

POWERTRON HAS COMPLETELY AC POWER SUPPLY



Transistorized Model has rectifier and filter in power supply — not an amplifier, where servicing is difficult. No batteries. Costs 27c to operate for full year. Battery types require \$5 to \$9 in batteries a year to operate continuously at maximum efficiency.



ONLY POWERTRON HAS RANGE CONTROL SWITCH TO PREVENT OVER-DRIVING TV SETS ON EXTRA STRONG CHANNELS.



ONLY POWERTRON HAS AC PLUG-IN OUTLET FOR TV SET BUILT INTO THE POWER SUPPLY.

POWERTRON IS 100% CORROSION-PROOFED — ANTENNA IS GOLD ANODIZED, ALL HARDWARE IRRIDIZED, AMPLIFIER HOUSING OF HIGH IMPACT PLASTIC.

ONLY THE POWERTRON CAN DO ALL THIS!

1. Powertron will drive up to 10 TV sets and each set will have a better picture than an ordinary antenna will deliver to one set.
2. Powertron will drive a TV signal through one-half mile of lead-in with signal to spare—permits you unprecedented flexibility for remote installations.
3. Powertron will virtually eliminate snow and interference even on an old TV set.
4. Powertron will deliver superlative color reception far better than a non-electronic antenna.
5. Powertron brings in stations beyond the reach of non-electronic antennas—delivers greatest reception distance.



AND WINEGARD POWERTRON is the only antenna presold to your customers—nationally advertised in the biggest consumer advertising campaign yet! So stock up now—take advantage of the demand Winegard is building for you.

Write for free technical bulletins.

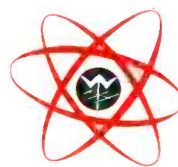

Winegard

ANTENNA SYSTEMS

Winegard Co., 3009-10 Kirkwood, Burlington, Iowa

Guaranteed against leakage...
and full of **sound power**—



Mallory Mercury Batteries



To protect your transistor radio against damage and to get more enjoyment from it, always use Mallory Mercury Batteries—the different batteries.

They're the only radio battery guaranteed against leakage. They give you far more **sound power** than 10 others up to seven times as many listening hours in your radio as ordinary batteries. They stay at full strength all their long life—no fading, no power loss when idle.

Try Mallory Mercury Batteries once, and you'll never settle for less. In popular sizes at stores near you.



*We guarantee to repair your radio and replace batteries, free of charge, if Mallory Mercury Batteries drain or lose and damage it. Send radio with batteries to Mallory Battery Co., 40 Elm Street, North Tarrytown, N.Y.

In Canada: Mallory Battery Company of Canada Limited, Toronto, & Ont.
In Europe: Mallory Batteries, Ltd., Weybridge, England.



Batteries available for hearing aids, calculators, watches and clocks, electronic instruments, military equipment.

A leaky battery
can ruin your
transistor radio



Mallory Mercury Batteries are guaranteed against leakage



Don't risk costly damage to your transistor radio by using ordinary batteries. Treat your radio right by using Mallory Mercury Batteries... the only radio battery guaranteed against leakage.

Greater sound power—A completely different kind of power cell. Mallory Mercury Batteries give you up to seven times more listening hours than ordinary batteries. They never fade, never lose power when idle. Try them in your radio. You'll be amazed at the difference they make. Stores near you have them in all popular sizes.

*We guarantee to repair your radio and replace batteries, free of charge, if Mallory Mercury Batteries should ever leak and damage it. Send radio with batteries to Mallory Battery Co., 40 Elm Street, North Tarrytown, N.Y.

Mallory Battery Company, North Tarrytown, N.Y.



In Canada: Mallory Battery Company of Canada Limited, Toronto, & Ont.
In Europe: Mallory Batteries, Ltd., Weybridge, England.
Batteries available for hearing aids, calculators, watches and clocks, electronic instruments, military equipment.

Step up your battery profits

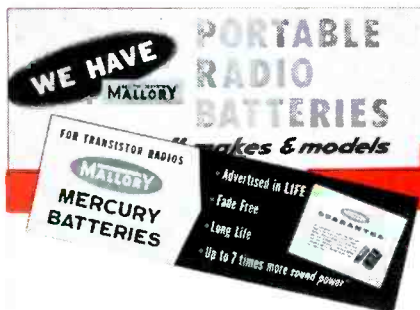

BRING PROSPECTS INSIDE...
with these bold window streamers.



BRING 'EM TO THE POINT OF SALE...
with store and window display material.



THEN SELL 'EM IN YOUR STORE...
from this new counter-top dispenser. A balanced stock of Mallory Mercury Batteries for all popular transistor radios... in new re-usable plastic jewel boxes. Packs fed one at a time. Guarantee boldly featured.

ADVERTISED IN
LIFE

LIFE ADS REACHING
34 MILLION PROSPECTS
Consistent Mallory advertising
in LIFE—telling them... and
selling them.

Mallory Mercury Batteries... the *sound power** battery... now come to you with a new *salespower program* to help you cash in on the booming transistor radio battery business. It's a big market... over 15 million transistor portables in use today, thousands more every month. And Mallory Mercury Batteries have the performance... the promotion... and the profitability... that lead the field.

New national advertising that pre-sells millions of customers this *different* battery.

New guarantee against leakage, unique in radio batteries... heavily promoted in national advertising.

New promotional materials—store banners, window displays, dealer ad mats, counter cards.

A new point-of-sale merchandiser—puts every dealer in the Mercury Battery business... balanced inventory... minimum investment... attractive display.

Plus... the unequalled performance of the most powerful batteries on the market. Up to seven times more sound power. Non-fading performance. Two years or more storage life.

And... *high profit per sale*... several times that of ordinary batteries.

See your Mallory distributor now. Get ready for the big battery selling season... with the fastest growing battery line!

*T.M.

with the Mallory '61 Program



Distributor Division
Indianapolis 6, Indiana



AND SELL 'EM AT HOME, TOO...

from the Mallory Mercury Battery Service Kit. Only 2" x 5" x 7", it fits easily in a corner of tube or tool caddy. Stocked with fast-moving Mallory Mercury Battery assortment to fit most popular transistor sets.

NEW GUARANTEE AGAINST LEAKAGE...

Display the Mallory guarantee that protects your customers. We guarantee to repair the radio and replace the batteries, free of charge, if Mallory Mercury Batteries should ever leak and damage a radio set.

ATR PRODUCTS FOR MODERN LIVING

ATR UNIVERSAL INVERTERS
A. C. Household Electricity Any where . . . car, boat or plane.

- Tape Recorders • TV Sets
- Dictating Machines • Radios
- Public Address Systems
- Electric Shavers • Record Players • Food Mixers • and Emergency Lighting.

NET \$66.34
6U-RHG (6 V.) 125 to 150 W. Shp. Wt. 27 lbs.
NET \$66.34
12U-RHG (12 V.) 150 to 175 W. Shp. Wt. 27 lbs.

Auto Plug-in Home-type Portable

ATR BATTERY CHARGERS
NO INSTALLATION . . . PLUG INTO CIGARETTE LIGHTER RECEPTACLE!
Keeps car battery fully charged in your own garage! Needed more now than ever before—makes motor starting easy! Operates directly from standard 110 volts A.C. current.

NET \$19.46
612CA4 (4 amp.) 6/12 V. Shp. Wt. 6 lbs.
NET \$22.46
612CA6 (6 amp.) 6/12 V. Shp. Wt. 8 lbs.
NET \$27.71
612CA10 (10 amp.) 6/12 V. Shp. Wt. 10 lbs.

ATR SHAV-PAKS
Keep Clean-Shaved! Plugs into Cigarette Lighter Receptacle. Keep in Glove Compartment. Operates Standard A.C.

- ELECTRIC SHAVERS
- Small Timing Devices . . . in CARS, Buses, Trucks, Boats, or Planes.

NET \$7.97
6-SPB (6 V.) 15 W. Shp. Wt. 2½ lbs.
NET \$7.97
12-SPB (12 V.) 15 W. Shp. Wt. 2½ lbs.

ATR TUBE PROTECTORS
Will Double or triple the life of all types of electronic tubes, including TV picture tube.
Automatic in operation, for use with any electronic equipment having input wattage of 100 to 300 watts. Fuse protected, enclosed in metal case for rugged construction and long life.

MODEL 250 (Wall Model) 115 V. A.C. Shp. Wt. 1 lb.
DEALER NET \$2.63

ATR MODERN TABLE RADIOS
Trim, modern clock radio in ebony or ivory plastic. Powerful 5 tubes including rectifier AM radio chassis with built-in "Magna-Plate" antenna. Full-toned 4" PM speaker. Popular features include: Musical Alarm—radio turns on automatically at any pre-set time; Sleep Selector—lulls user to sleep; Automatic Appliance Timer—outlet on back of radio times any electric appliance automatically (up to 1100 watts). Cabinet 10½ in. wide, 5 in. high, 5½ in. deep. Wt. approx. 8 lbs.

Model T-91

Clock Specifications:

- Genuine Telechron Movement.
- Self-Starting . . . Never Needs Winding, Oiling, or Regulating.
- Simplified Clock Controls for Radio and Sleep Switch.
- 1100 Watt Controlled Outlet.
- Automatic Buzzer Alarm.
- Gold-Plated Bezel and Numerals on Large Bone-White Dial. UL Approved.

ATR HAND WIRED—NO PRINTED CIRCUITRY "TILT-A-STAND" RADIO
MOUNT ON THE WALL—UNDER A SHELF—OR SET ON A TABLE. PERFECT for every room in YOUR home.
Power-packed 5 tubes including rectifier chassis. Built-in loop antenna. Automatic volume control. Full 4" Alnico 5 speaker. Distinctive Roman numerals on dial. Size: 9½" W x 4" D x 5¼" H. AC/DC. U.L. approved. Beautiful bakelite cabinet—Resists heat. Shipping Weight 5½ lbs.

Model T-87

Model T-91 Clock Radio, Black . . . NET \$22.45
Model T-91 Clock Radio, Ivory . . . NET 23.15
Model T-87 (Tilt-A-Stand), Black . . . NET 17.47
Model T-87 (Tilt-A-Stand), Red . . . NET 18.10

SEE YOUR ELECTRONIC PARTS DISTRIBUTOR WRITE FACTORY FOR FREE LITERATURE.

ATR AMERICAN TELEVISION & RADIO CO.
Quality Products Since 1931
SAINT PAUL 1, MINNESOTA—U.S.A.

LETTERS TO THE EDITOR

Dear Editor:

I'll be very pleased if you can tell me where I can get some information on stereo FM (multiplex) systems.

ROMANO MOGLIA

St. Petersburg, Fla.

We're cooking up a feature article on this subject, with a highly practical slant, for the December issue.—Ed.

Dear Editor:

Have you considered covering the electrical systems of cars as you have done for radio, TV, and industrial electronics? I have been reading your magazine for the past five years but don't recall any article dealing with the above subject.

D. FORDE

Boston, Mass.

We don't feel that conventional automotive electrical systems are within our scope, but we have thought of doing an informational article on transistorized ignition systems when they become more widely used. Okay?—Ed.

Dear Editor:

In skimming through the July issue, I was stopped on page 62 when I saw the thyatron tube V2 in Fig. 4. How could it work with the cathode and plate shorted together? Evidently, this wire connection is superfluous.

In actual circuits of this type which I have worked on, R4 would not be placed

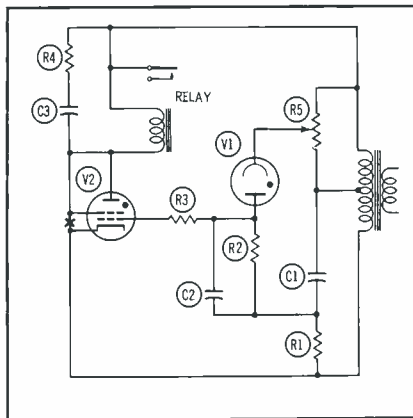

in series with C3 where it would reduce the filtering action of the latter. Instead, this resistor (usually on the order of 1000 ohms) would be directly in series with the thyatron plate. Then, if the relay became shorted, little damage would be inflicted on the tube. However, if the circuit were wired as in Fig. 4, a shorted relay would place the full supply voltage across V2 and probably damage it.

M. G. GOLDBERG

Beacon Radio & TV Service
St. Paul, Minn.

The cathode-plate connection is not only superfluous — it doesn't belong on the schematic! Our face is about the color of an overdriven thyatron; all the same, we thank you for passing along the additional information.—Ed.

Dear Editor:

Since schematics are easily soiled and damaged through frequent bench use, I have made several "Sams Savers" to protect the PHOTOFAC Folders I use in my shop. They work so well that I thought I'd write to you and pass the idea on to other servicemen.

The protector is very simple to make. All you need is a 27" x 13" piece of ¼" plywood as a base for the older schema-

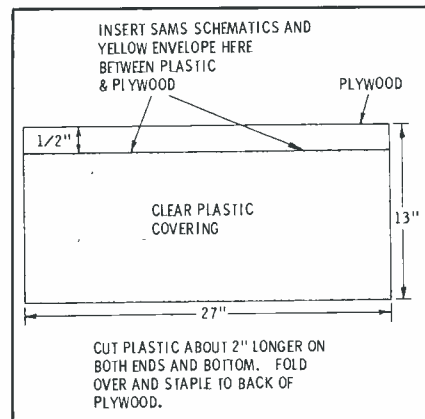

tics (or a shorter piece for the Folders covering newer models) and a piece of clear plastic to serve as a cover. I prefer the type of plastic used in making auto seat covers, since it's heavier than most other kinds.

I've enclosed a sketch of this service aid. It doesn't look like much, I'll admit—but it certainly saves wear and tear on one of the finest "tools" a TV shop can own.

JOHN B. HUCKALY

John's Television Service
Eunice, La.

Sounds like a good suggestion, John. We'd like to hear what other PHOTOFAC users think of the idea.—Ed.

Dear Editor:

Your efforts to help servicemen earn a little extra money by repairing small appliances (page 30, August issue) may result in some unhappy housewives. According to the wire table published in this article, the average iron or toaster (which draws approximately 1000 watts) would require a #8 wire. Try it on your wife! Generally speaking, such appliances use a #16 asbestos-wrapped cord. And the sloppy, inconvenient type of cord termination shown in the article can be easily avoided with a 2" strip of Scotch No. 27 thermosetting glass tape.

If the serviceman really plans to add small-appliance service to his line, let's not mislead him into thinking he can do it with a handful of parts and no other equipment. When you consider the necessity for wattmeters, temperature-sensing devices, service manuals, and the special tools required for some of the more

**Please turn to page 22*

"STRIP" and "STRAP"

...your 2 key words to profit protection

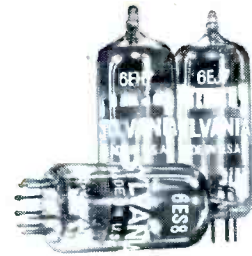

"Strip" is the new BIKINI CATHODE construction. "Strap" is the new FRAME GRID design. Both . . . developed by Sylvania . . . are creating new excitement, bringing new performance standards to TV sets.

BIKINI CATHODE—a precast film-strip of active materials is bonded, by a special Sylvania technique, *only* to the 2 flat surfaces of the cathode sleeve. Results: eliminates stray emission from the sides of the cathode for improved cutoff and noise characteristics, enhances tube-to-tube uniformity, minimizes grid-to-cathode arcing.

STRAP FRAME GRID—grid lateral wires are solidly supported by a sturdy, ladderlike construction enabling use of ultra-fine wire and tight spacing between grid and cathode. Results: reduces possibility of grid-cathode shorts, decreases microphonism and noise, provides unusually high Gm . . . higher performance than ever before available in tubes for TV sets.

Sylvania 4EH7 and 4EJ7, 6EH7, 6EJ7 and 6ES8 now feature the advantages offered by BIKINI "strip" CATHODES and STRAP FRAME GRIDS. So, when the time comes for replacement of those tube types, protect your service profits by installing SYLVANIA. At your distributor's now!

Electronic Tubes Division, Sylvania Electric Products Inc., 1740 Broadway, New York 19, N. Y.

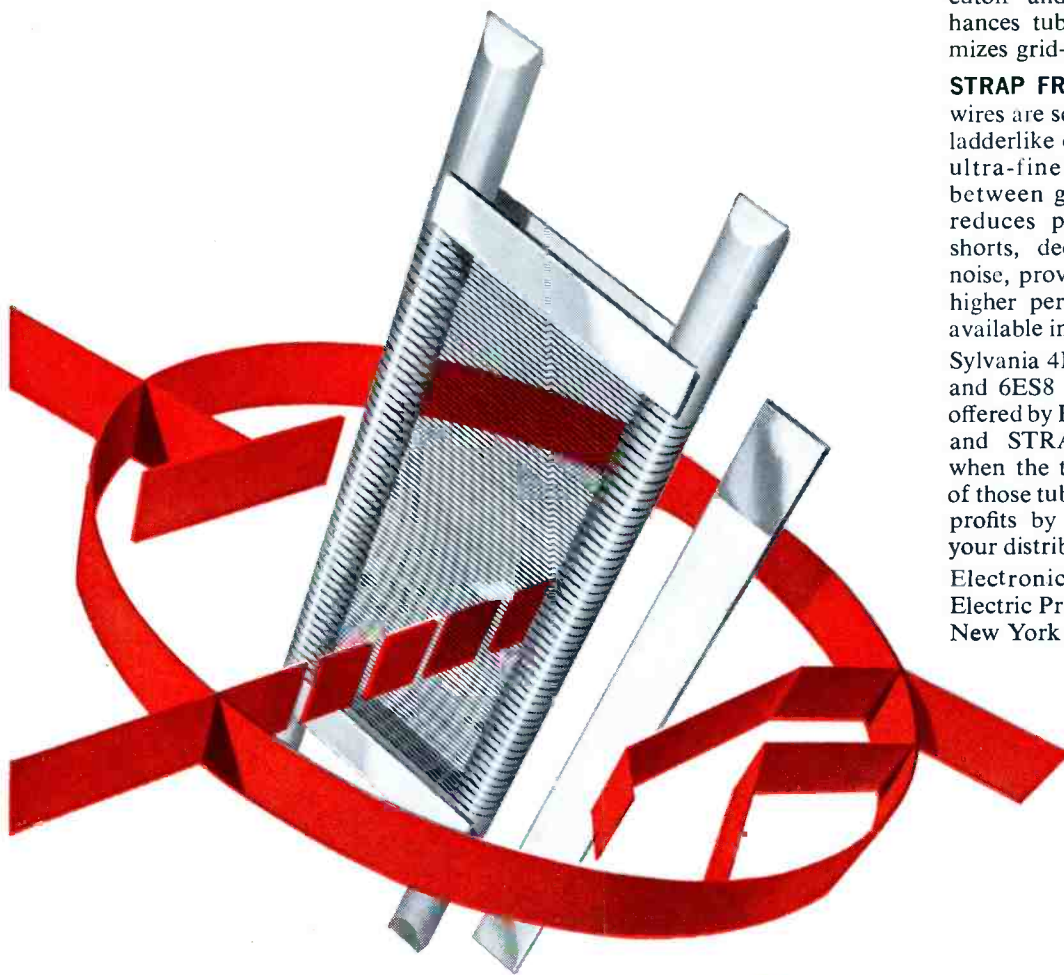

SYLVANIA

SUBSIDIARY OF

GENERAL TELEPHONE & ELECTRONICS



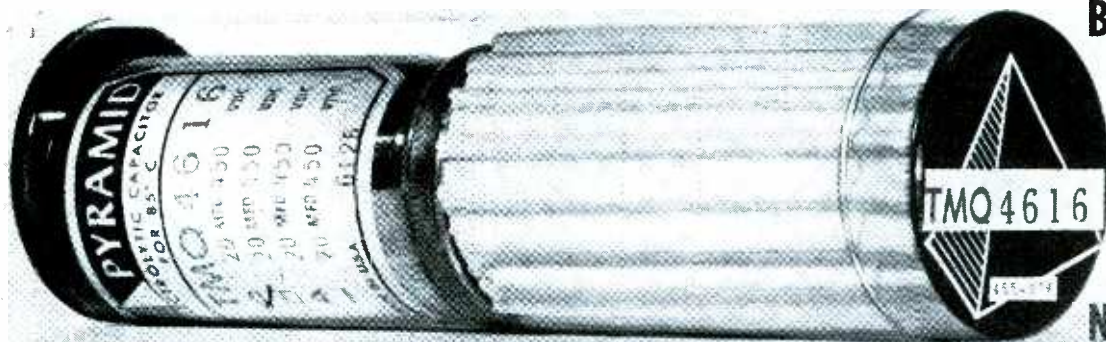

**BEHIND THIS CAP IS A
COUPON WORTH UP
TO \$2.00 ■ EVERY
PYRAMID TWIST-
PRONG ELECTRO-
LYTIC YOU BUY FROM
NOW TO DECEMBER 31,**

WILL HAVE A COUPON WRAPPED IN IT THAT'S WORTH UP TO \$2.00! IT'S OUR WAY OF CELEBRATING WITH YOU THE MERGER OF PYRAMID WITH MICAMOLD TO FORM THE GENERAL INSTRUMENT CAPACITOR DIVISION ■ JUST GO TO YOUR PYRAMID DISTRIBUTOR, PICK THE TWIST-PRONG VU-PAKS YOU NEED FROM HIS CAPAC-O-MAT RACK, UNROLL THE WRAPPER AND CASH IN THE COUPON. COUPONS RANGE IN VALUE FROM 5c TO \$2—AND EVERY VU-PAK HAS ONE! BUT THAT'S NOT ALL. YOU GET A RELIABLE, PYRAMID ELECTROLYTIC THAT MEETS EVERY REQUIREMENT YOU SET FOR A TWIST-PRONG, SO YOU'RE A WINNER TWO WAYS. SEE YOUR DISTRIBUTOR TODAY. GENERAL INSTRUMENT CAPACITOR DIV., GENERAL INSTRUMENT CORP., DARLINGTON, S.C.

TRAIN . . .

THEN SHARE THE PROFITS



IN THE BOOMING COMMERCIAL TWO-WAY AND CITIZENS BAND RADIO SERVICE BUSINESS

HERE'S HOW RAYTHEON WILL HELP YOU —

Now Raytheon can train you and franchise you as a Certified Raytheon Service Station operator, qualified to service Raytheon's expanding line of commercial two-way and citizens band radio equipment, as well as other brands. There are 2.5 million units in use today, and the number is growing every day!

TRAIN TO SERVICE — Raytheon's Communication Technician's Correspondence course will give you a thorough groundwork in the operation, installation and maintenance of this equipment. On completion of the course, you will be qualified to take the exam for the FCC Class II license which is required for servicing CB and commercial two-way radio. The cost is \$96.00 and it is available either direct or through your local Raytheon distributor.

PROFIT AS A RAYTHEON CERTIFIED SERVICE STATION — Then, with Class II license and adequate test equipment you can become one of a national network of independent service facility operators franchised to service Raytheon Ray-Tel CB equipment. Operating a Certified Service Station, you'll be reimbursed by Raytheon for all authorized parts and labor required in repair of in-warranty Ray-Tel units.

MAIL THIS COUPON NOW

Mail this coupon now for full details. Join others cashing in on this growing new field.

RAYTHEON COMPANY

Distributor Products Division
411 Providence Turnpike
Westwood, Massachusetts
Box No. 26

- Please send me your brochure describing the Raytheon Communication Technician's Course.
- Please send me details on the Raytheon Certified Service Station Service Program.

Name _____

Company Name _____

Address _____

City _____ State _____

Name and Address of Raytheon Distributor _____



RAYTHEON COMPANY

DISTRIBUTOR PRODUCTS DIVISION

**VALUABLE SAMS BOOKS ON
TEST EQUIPMENT**
available from your local
SAMS DISTRIBUTOR



Famous "101 Ways" Series
BY BOB MIDDLETON

These wonderfully practical books will help you put your test equipment to work more frequently and profitably. Bob Middleton shows you simply and clearly how to apply each instrument, how to make proper connections, what added equipment is needed, proper test procedure and evaluation of results. Each book is handy 5½" x 8½" size and fully illustrated.

- 101 Ways To Use Your Sweep Generator.** 144 pages. No. TEM-1. Only.....\$2.00
- 101 Ways To Use Your Oscilloscope.** 180 pages. No. TEM-2. Only.....\$2.50
- 101 Ways To Use Your VOM & VTVM.** 116 pages. No. TEM-3. Only.....\$2.00
- 101 Ways To Use Your Signal Generator.** 128 pages. No. TEM-4. Only.....\$2.00
- 101 Ways To Use Your Audio Test Equipment.** 136 pages. No. TEM-5. Only.....\$2.00
- 101 Ways To Use Your Ham Test Equipment.** 168 pages. No. TEM-6. Only.....\$2.50
- 101 More Ways To Use Your Scope in TV.** 160 pages. No. TEM-7. Only.....\$2.50



Know Your Oscilloscope. Covers circuitry, operation, adjustments, servicing and applications of oscilloscopes. Chapters include: Power Supplies; Sweep Systems; Synchronization; Amplifiers; Special Features; Accessories; Adjusting and Servicing; Frequency and Phase Measurements; Radio and TV Alignment; Practical Applications and Servicing Procedures. 160 pages, 5½" x 8½" x 11". No. KOS-1. Only.....\$2.00

How To Understand and Use TV Test Instruments. Revised and enlarged to include latest data on instruments for servicing Color TV. Tells how each instrument operates, how to use and get the most from it. Covers: VTVM's, Signal Generators, Sweep Generators, Scopes, Video Signal Generators, Field Intensity Meters and Voltage Calibrators. 176 pages, 8½" x 11". No. TN-1. \$3.50 (Revised). Only.....

Servicing and Calibrating Test Equipment. Shows you how to keep your test instruments in reliable working order. Explains proper operation of instruments, calibration procedures, simple ways to check instrument accuracy, how to service test equipment. 190 pages, 5½" x 8½", illustrated. \$2.75 No. TEK-1. Only.....

Using and Understanding Probes. Analyzes and describes uses of various probes: direct, isolation, high-voltage, low-capacitance, rectifying, demodulator, signal-tracing, signal-injection and special purpose. Includes industrial as well as TV and radio applications. 192 pages: 5½" x 8½". No. PRG-1. \$3.95 Only.....

FREE SAMS BOOKLIST AVAILABLE—ask your Distributor or write us direct

HOWARD W. SAMS & CO., INC.
1720 E. 38th St., Indianapolis 6, Ind.
In Canada: A. C. Simmonds & Sons, Ltd., Toronto 7

Letters

(Continued from page 18)

common appliances, I'd suggest that he either get into this business wholeheartedly, or leave the things entirely alone.

JOHN A. CROCKER

Fort Wayne, Ind.

P.S.: We're in it, up to our necks!

APPLIANCE RATING (MAX. WATTS)	WIRE SIZE TO USE (GAUGE NO.)
1200	18
1800	16
2400	14
3600	12

Here is a revised chart which should cheer up the housewives, and also set the record straight in regard to the wire situation. The figures are based on the current-carrying capacity of flexible cords (types AFS, AFSJ, HC, HPD, HSJ, HS, and HPN) as recommended by the National Electrical Code of 1956.

These ratings are for not more than three current-carrying conductors in any one cord. Wires with other types of insulation may be rated lower.—Ed.

Dear Editor:

The beginning of the fourth paragraph in the August article, "Where'd the Boost Go?" says, "The output stage, flyback transformer, and yoke must be operating normally for proper development of boost voltage." This could be a little misleading, since boost voltage will be developed with the yoke disconnected from the circuit. Also, I believe that a discussion of boost should also mention high voltage, since this will be missing when there is no boost, or lower than normal if boost is lower than it should be. However, it is possible for the boost voltage to be normal, or even greater than normal, with no high voltage at all. This will happen in a normal circuit if the yoke is disconnected.

Here is a very convenient test to make if you suspect that either the flyback or the yoke is causing a loss of boost voltage. Merely disconnect the yoke; if it is defective, boost will rise to at least the normal value, but there will be no high voltage. If boost voltage does not return during this test, it can be assumed that the yoke is good and the trouble is in the flyback. By the way, this discussion does not apply to direct-drive circuits.

ROBERT FEURER

Marion, Ill.

We could split hairs over the word "proper" in the paragraph you quoted from, but it makes more sense to agree with you—boost will be nearly normal if the yoke is open, except in a direct-drive

circuit. However, some high voltage will likewise be developed. It obviously won't be up to normal, since the energy normally stored in the yoke is absent; but it may be as much as half the normal amount. Thanks for volunteering your help.—Ed.

Dear Editor:

You did not throw a curve ball last April, as Bob Hill charged in the August Letters column. You balked! You are way off base when you list a sweep and marker generator over a tube checker. Everybody will agree that a VTVM or a good VOM comes first, but a good tube checker comes next. I took a poll of all the shops around us, and they all agree.

We have a standing rule in our shop that, if a set is brought in for bench service, all tubes are run through our transconductance tube tester. You would be surprised at the number of "half tubes" we find operating in sets—tubes with shorts, and those with high-resistance grid leakage. Our tube checker has saved the day on many a service problem.

We have no need for a sweep generator, although we do the bench work for five other TV service companies. (We had both sweep and marker generators at one time, but we sold them both for \$50 just to get them off the bench.) Even our scope gets very little use. About 95% of the troubles in TV, radio, hi-fi, and car radio sets are found with our tube checker and VTVM. Our shop has been in business since 1948, and with these instruments, we will still be in it for many years to come.

CHARLIE BENNETT

Service Manager

Miller's Music & Hi-Fi Store
Baltimore, Md.

No doubt about it—tube testers are a big help in finding troubles. But, for troubleshooting the real toughies, our choice is still a scope and generator.—Ed.

Dear Editor:

I wonder how many of your readers have noticed that the Subject Reference Index card in your July issue is labeled with the wrong month (June). Don't feel unhappy about this; I have bad days, too, and I guess these are to be expected once in a while. I haven't found any real faults in PF REPORTER since your first issue in January, 1951. Times have changed since then, but so has your magazine. That's what I like about it—always something new.

WILLARD ROBERTS

Jacksonville, Ark.

You were the first to tell us of the goof on the card, Will. Glad to hear it didn't change your opinion of us. Many thanks for your consoling thoughts.—Ed.

Dear Editor:

I agree with John J. Zeder; I like your articles but some of them make us read too far to get to the "meat."

DELWIN IRELAND

Star, Idaho

Now all we need to know is how you like it—rare, medium, well done, or charred to the bone?—Ed.

What type
of TV Lead-in
Cable do you
need?

Your
Belden Jobber
has it!

Convenient lengths
in coils and
spools

Belden

WIREMAKER FOR INDUSTRY
SINCE 1902 — CHICAGO

Cord Sets and Portable Cordage •
Electrical Household Cords • Magnet
Wire • Lead Wire • Automotive Wire
and Cable • Welding Cable

WELDOHM, PERMOHM, CELLULINE
are Belden Trademarks
Reg. U. S. Pat. Off.

*Belden Patents U. S. 2782251 and 2814666



WELDOHM . . . two and a half times
the flexing life and one and a half times
the breaking strength of ordinary lead-
in. Resists pulling, whipping, twisting.
300 Ohm. No. 8230.



PERMOHM* . . . for use under condi-
tions of extreme salt spray, industrial
contamination, rain, and snow. Gives
stronger, clearer signals. 300 Ohm.
No. 8285.



STANDARD 300-OHM LINE . . . of-
fers low losses at high frequencies. Also
ideal for use with FM receiving an-
tennas. No. 8225.



DECORATOR CABLE . . . this new
300-ohm lead-in cable is of ivory color
— blends into any interior decorating
arrangement. No. 8226.



CELLULINE* . . . excellent resistance
to sun, abrasion, and wind. Installation
easy . . . no end-sealing necessary. Gives
strong UHF and VHF TV pictures.
300 Ohm. No. 8275.

8-1-1

ATTENTION SERVICEMEN—DEALERS! WESTINGHOUSE ANNOUNCES

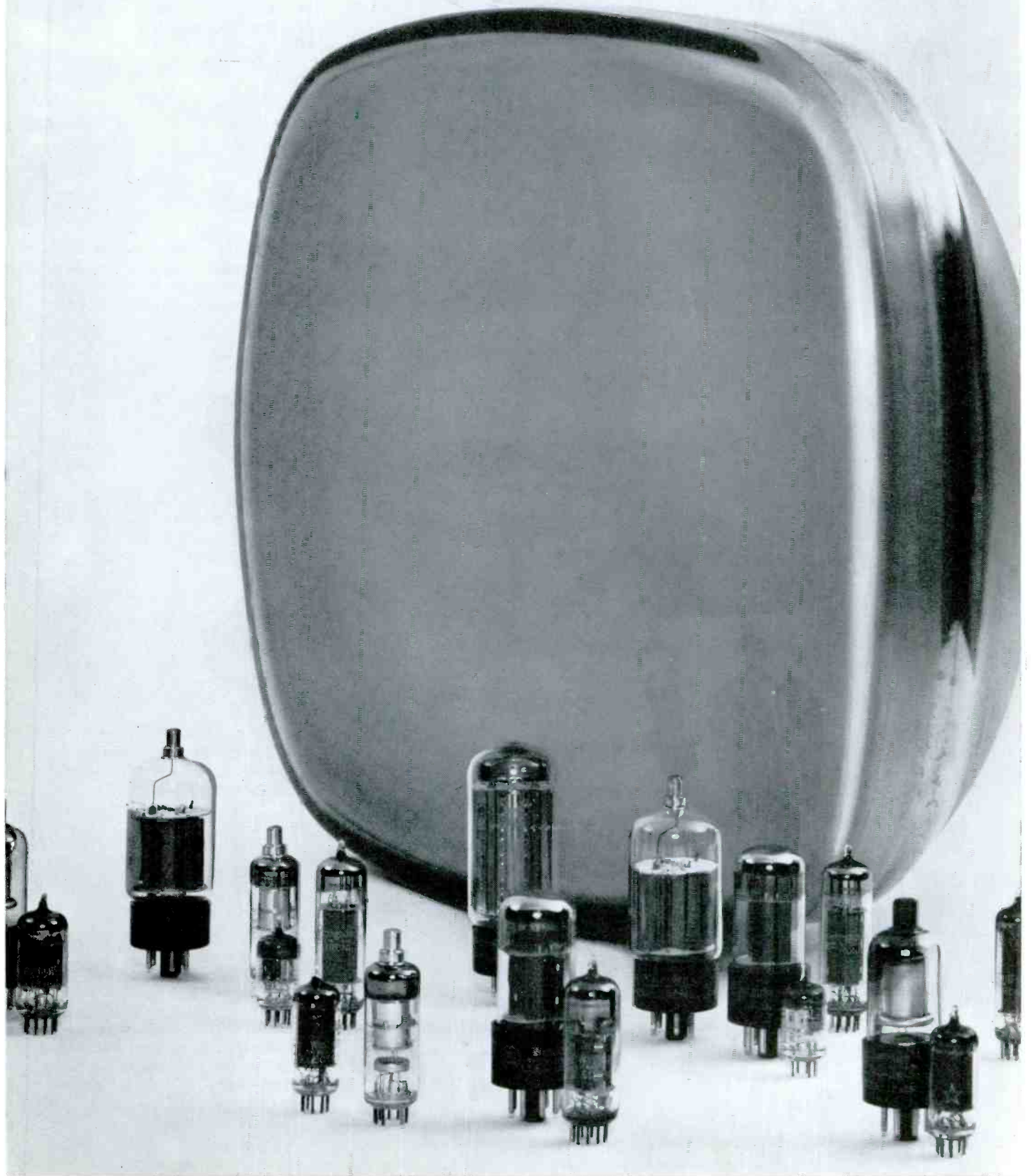

A NEW MARKETING CONCEPT IN ELECTRONIC TUBE DISTRIBUTION

Your Westinghouse electronic tube distributor will soon benefit from a dynamic new marketing program. He will be able to extend to you many of the benefits of this unique plan which will generate greater profitability and promote sound business relationships between manufacturer-distributor-dealer. Here are the important facts concerning this program:

1. HIGHER PROFIT MARGINS—Westinghouse tube production facilities have been developed over the years to where they now have no peer in craftsmanship and manufacturing skill. This results in exceptionally fine product quality, which together with competitive product cost ratios afford the opportunity to produce favorable, realistic and constant profit margins.

2. THE ULTIMATE IN FINANCING PLANS—At long last: a plan that recognizes the fiscal needs of the distributor and is based upon sound principles of money management. A financially responsible distributor can now buy Westinghouse electronic tubes with a flexible line of credit which allows him to maintain complete control of his own business affairs.

3. EXPERT MARKETING COUNSEL—To help solve distributor problems related to distribution patterns, co-op advertising, promotional and merchandising programs, Westinghouse has installed a team of experienced marketing executives. A key member of this team is our advertising agency, McCann-Erickson, Inc., with its complete marketing services and nation-wide facilities.

4. EXCLUSIVE FINANCIAL COUNSEL—To help solve problems in the areas of credit control, inventory turnover, cash flow and operating ratios, Westinghouse offers to franchised distributors the counsel of financial experts. These money "trouble shooters" are Westinghouse corporate treasury officials, in offices strategically located coast-to-coast.

5. FAST TIE-LINE SERVICE—To reduce inventory problems and to minimize out-of-stock risks, Westinghouse has developed a new, improved order processing method in field offices and at the factory. A franchised distributor's order is filled within one hour of receipt.

6. INDUSTRY INNOVATIONS—Westinghouse is constantly developing new ways to package and merchandise electronic tubes to distributor . . . to dealer . . . to consumer. For example, the bold, distinguished package design coming soon for all Gold Star tubes.

Westinghouse Electric Corporation, Electronic Tube Division, Elmira, N.Y.
You can be sure . . . if it's Westinghouse.

Westinghouse

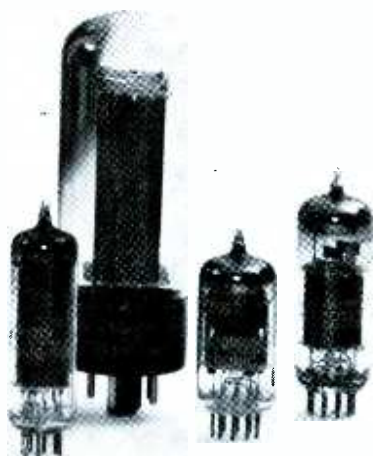

THERE'S NEW *POWER* IN WESTINGHOUSE TUBES

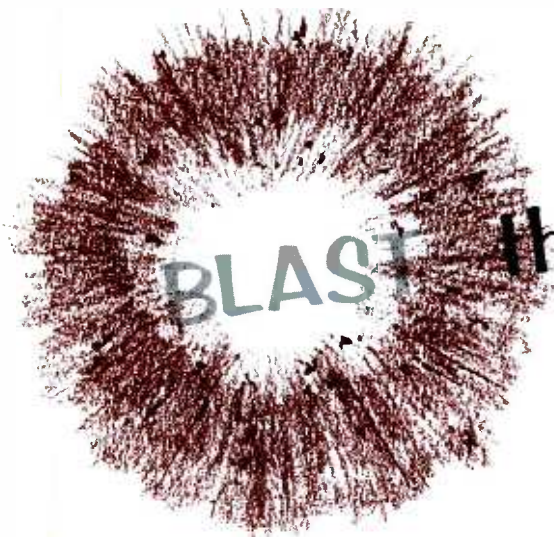

those TV Intermittents

Special techniques for ferreting out troubles in "hibernations."
by Jack Darr

"When intermittent come in door, profit fly out window."

—OLD CHINESE PROVERB
BROUGHT UP TO DATE

Continual servicing of intermittents is, without a doubt, the best method ever devised for reducing the net income of a TV service shop. However, there are ways of dealing with intermittents that will reduce the total bench time consumed. From over 30 years of experience, I can tell you that the best way is the *methodical* attack. Haphazard, hopeful "twiddling" will get you nowhere. Look at the problem calmly, and see if there isn't a handle on it somewhere. My favorite approach is the "Three-I" method: Interrogation, Investigation, and Information. To this might be added a fourth I, "Inspiration", but most intermittents are fixed by the first three. Most inspirations generally prove to be entertaining, but entirely incorrect!

Interrogation

Question the customer carefully. He's been watching the set act up for quite a while before he called you, and the more information you can get, the easier your job is going to be. Explain to him that the more

facts you have on *exactly* how the set has been acting, the less time you'll have to spend on it, and the lower the service charge will be. This will usually make him *very* cooperative! Get *all* the symptoms: Does the trouble show up when the set is first turned on, after it's been on for five minutes, after two hours, or when? Does it affect the picture, sound, raster, or what? Is any kind of popping or frying noise heard when the trouble shows up? Is there a smell of something burning? Can operation be brought back to normal by jarring the set? Does the trouble happen at the same time every day, or at odd intervals? You're going to get some pretty weird answers, but the skilled technician becomes adept in translating replies like "It goes *gizzledewhop* every time I step on this board right here!", or "The picture goes BRRRRPPPP!"

To win the cooperation of the customer, choose your words carefully. For example, *never* inquire, "What's the matter with the set?" Just as an experiment, I deliberately used this phrase on 20 service calls. On 17 of them, I was told, "That's what we called *you* for, to find out!" You'll get much better results from asking specific questions such as, "Is the trouble in the picture, the sound, or both at the same time?" Does the screen go dark, or does the picture go away and leave the screen a smooth white?" "Does the sound go off when the picture goes out?" and so on. About three or four questions like this, and the technician can "sectionalize" the trouble within a remarkably small

area of the set, thus speeding the job up tremendously.

Be leery of accepting an intermittent with a time limit for delivery. Explain to the customer that because the trouble isn't there all the time, it's going to be hard to find. You can say, "There are hundreds of connections, and it could be any one of them." Or you can tell him you could fix the set in five minutes if it were completely dead and stayed dead; but as it is, you'll have to take a little extra time to be sure that you have found the trouble. In other words, phrase your answers to convey the idea that you know exactly what's wrong with the set, but the repair is going to take longer than usual because the TV set won't cooperate with you. Never give a customer the impression that you're stuck, even if you are. Make a special effort to hold back the words, "We might not find the trouble." Let him believe that if this stubborn TV set will just show up the trouble while in your shop, you'll find it in no time! Try to get the owner to feel that you and he are working together against the bull-headed TV set. And don't think it doesn't pay

• Please turn to page 87

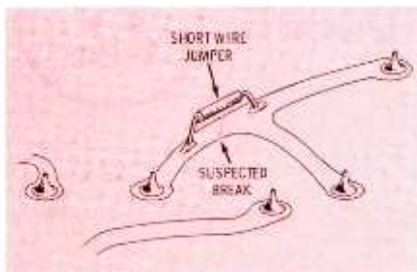

Fig. 1. Use a bridge of hook-up wire to check for a crack in PC conductor.



Fig. 2. Heat lamp wrapped with aluminum foil makes set "intermit" in shop.

Harman-Kardon Enters The Sound Field Because...

...the sound industry is on the threshold of an exciting new era of growth. However, the ever-expanding use of sound places new demands upon the operational capabilities of equipment. It calls for new and higher standards of performance. The continued progress of our industry should not be impeded by equipment that is the result of old habits and customs; by equipment that simply does not measure up to the needs of the day and does not consider in toto the soundman's point of view.

The popular priced Commander Series is the first of a line of commercial and industrial sound products to be introduced by Harman-Kardon. In subsequent months additional lines will be presented. This equipment is the result of a new and refreshing approach to practical application requirements. Harman-Kardon brings to the sound field the full resources of a dynamic, successful organization, plus a superb engineering staff steeped in many years of experience in commercial and industrial sound. It is no accident that the Commander Series is in fact "deluxe" equipment at a popular price. This reflects the modern and highly efficient production techniques that have long been used to manufacture equally outstanding values found in Harman-Kardon high fidelity products. They also reflect the remarkable level of performance demonstrated by H-K's universally acclaimed Citation line. As you can see, the ingredients of quality, dependability, and a maintenance of high level of performance—so important in sound work—are not new to us at Harman-Kardon.

We urge you to carefully consider the new Harman-Kardon commercial and industrial sound equipment. Talk it over with your distributor or write to us for the full story. You'll quickly discover why the new Commander Series will do more, do it better, and for longer.

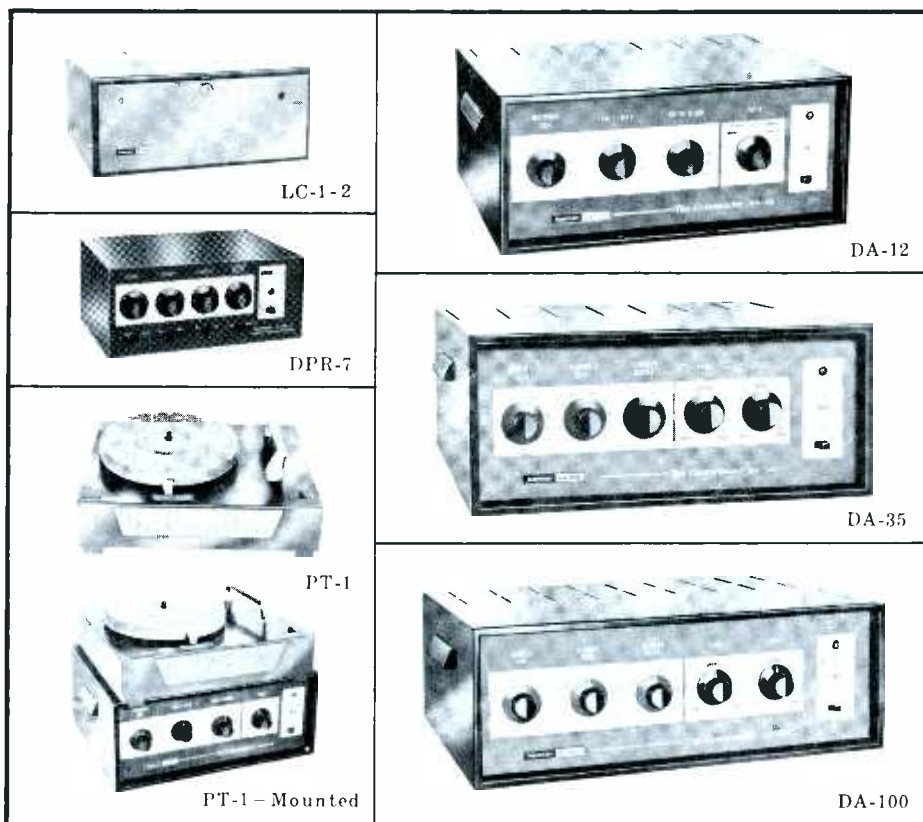

A SOUND APPROACH to Commercial and Industrial Application... THE NEW COMMANDER SERIES BY HARMAN-KARDON

Flexible. Versatile. Dependable. That's the new Harman-Kardon Commander Series of amplifiers and systems for commercial and industrial sound use. They're ruggedly constructed for continuous duty. They include deluxe features at popular prices. They're designed and manufactured by Harman-Kardon—noted for the quality, reliability and superb performance standards of its high fidelity products, including the highly acclaimed Citation Kits. *In short:* the new Commander Series is built BY soundmen—FOR soundmen. Here are some of the exclusive features that make these the best instruments you can buy for the price.

MASTER VOLUME CONTROL: Enables total amplifier output to be varied without disturbing other control settings. **MIXER CONTROL:** Convenient ONE KNOB control permits fading and blending of signal from two channels, in any desired amount. (DA-35, DA-100) **MULTIPLE INPUTS:** All at the rear—allow for an unusually high degree of installation and operational flexibility. **ANTI-FEEDBACK FILTER:** Equalizes frequencies most sensitive to generation of feedback "howl" without reducing articulation—thus achieving maximum power output under difficult acoustical conditions. (DA-12) **25 AND 70 VOLT OUTPUTS:** Provides two constant voltage systems—70 and the newer 25 volt balanced system—for optimum flexibility and economy in speaker installation. **LOCKING COVERS:** Unique feature on units in this price class—designed to prevent tampering or accidental change of precise control settings. **PLUS:** Magnetic Cartridge Input; Tape Recorder Output; Independent Power Switches; and many other deluxe features.

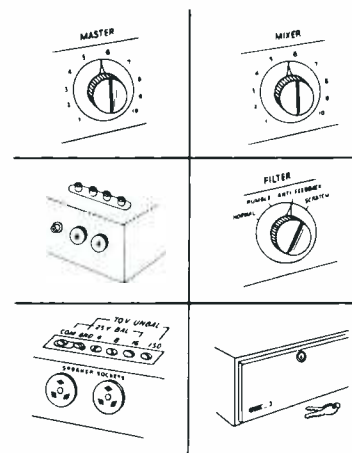

The Commander Series shown above includes the following: Model DA-12, 12 Watt PA Amplifier—\$75.00 List; Model DA-35, 35 Watt PA Amplifier—\$119.95 List; Model DA-100, 100 Watt PA Amplifier—\$187.50 List; Model DPR-7, Combination Mixer/Preamplifier—\$75.00 List; Model PT-1, Phonograph Top—\$37.50 List; Model LC-1 and LC-2, Locking Panel Covers: Model LC-1—\$8.50 List, Model LC-2—\$9.00 List.

For informative catalog on complete Commander Series write Desk 10H.

Commercial Sound Division

harman kardon

Harman-Kardon, Inc.
Plainview, N. Y.

STOCK GUIDE

FOR TV TUBES...

This edition has been enlarged to reflect the continual increase in the number of active tube types. Even so, it omits over 50 of the rarest types, which many shops do not find it practical to keep in stock. To simplify the chart as much as possible, common radio and hi-fi tube types used in TV combinations are omitted: so are special color and UHF types.

The figures on a gray background suggest a stock of 350 tubes which should account for over 90% of your replacement needs, and should minimize your risk of being "caught short" even if you travel all day without refilling your tube

caddy. However, if you prefer a more limited caddy stock, the other set of figures (on white background) will help you decide which types to cull out. These figures indicate the number of tubes of each type you could expect to find in a random sample of 1000 tubes taken from all TV sets now in service. Where the usage figure is well below 1 per 1000, a dash is shown. To scale down your stock, you can omit many "dashed" types, and also reduce quantities of other types. In so doing, keep in mind three other factors besides usage rates which influence the demand for various tubes:

1. Relatively high failure rate of

power output and similar types.

2. Your specialization in certain makes of sets, such as regional brands.
3. Average age of sets containing a particular tube type.

Temporary substitution of available types for rare types, as outlined in the Howard W. Sams book, **Tube Substitution Handbook, Vol. 3**, can also help you reduce stock requirements.

Another way to ease tube-stock headaches is to use only the latest -A or -B versions of various tubes. Types in common use are listed in the chart.

PER 1000	CADDY STOCK	TUBE TYPE	PER 1000	CADDY STOCK	TUBE TYPE	PER 1000	CADDY STOCK	TUBE TYPE	PER 1000	CADDY STOCK	TUBE TYPE	PER 1000	CADDY STOCK	TUBE TYPE
29	2	1B3GT	—	1	5A54	24	3	6AX4GTB	1	1	6CU6	—	1	6FY5
11	2	1G3GT	—	1	5A58	4	1	6BA6	1	1	6CU8	3	1	6GH8
5	1	1J3	1	1	5AT8	2	1	6BA8A	—	1	6CW4	—	1	6GK5
2	1	1K3	—	1	5AV8	3	2	6BC5	2	1	6CX8	—	1	6GK6
—	1	1S2A	—	1	5AU4	2	1	6BC8	2	2	6CY5	1	1	6GM6
7	2	1X2B	—	1	5B8	3	2	6BE6	1	1	6CY7	1	1	6GN8
2	2	2BN4	1	1	5BK7A	—	1	6BF6	1	1	6CZ5	—	1	6GW6
—	1	2CW4	1	1	5BR8	2	2	6BG6GA	1	1	6DA4	—	1	6GX6
3	2	2CY5	—	1	5BW8	2	1	6BH8	—	1	6DB5	—	1	6GY6
—	1	2FH5	4	2	5CG8	—	1	6BJ8	5	1	6DE4	—	1	6HF8
—	1	2GK5	2	1	5CL8A	1	1	6BK5	4	2	6DE6	—	1	6HJ8
2	1	3A3	1	1	5EA8	6	2	6BK7B	1	1	6DE7	—	1	6HL8
1	1	3AL5	—	1	5EU8	4	2	6BL7GT	2	1	6DG6GT	—	1	6HS8
3	2	3AU6	—	1	5EW6	—	1	6BL8	4	1	6DK6	1	1	6J5
—	1	3BC5	—	1	5GH8	2	2	6BN4	—	1	6DM4	11	2	6J6
3	2	3BN6	—	1	5GM6	8	2	6BN6	2	1	6DN7	—	1	6JE8
4	2	3BU8	—	1	5J6	2	1	6BN8	18	3	6DQ6B	4	2	6K6GT
19	2	3BZ6	2	1	5T8	6	2	6BQ5	2	1	6DR7	—	1	6K11
9	2	3CB6	35	3	5U4GB	11	2	6BQ6GTB	—	1	6DS5	1	1	6S4A
2	1	3CS6	6	2	5U8	10	2	6BQ7A	—	1	6DT5	—	1	6SL7GT
1	1	3CY5	3	2	5V3	1	1	6BR8A	9	2	6DT6	36	3	6SN7GTB
1	1	3DG4	—	1	5X8	—	1	6BS8	—	1	6EA5	1	1	6SQ7
2	1	3DK6	2	2	5Y3GT	6	2	6BU8	1	1	6EA7	9	2	6T8
6	2	3DT6	—	1	6AB4	—	1	6BW8	7	2	6EA8	13	2	6U8A
—	1	3GK5	2	1	6AC7	—	1	6BX7GT	5	2	6EB8	1	1	6V3A
—	1	3GS8	—	1	6AF3	3	1	6BY6	—	1	6EH7	9	2	6V6GT
—	1	4AU6	3	1	6AG5	1	1	6BY8	—	1	6EJ7	6	2	6W6GT
—	1	4AV6	—	1	6AG7	28	2	6BZ6	1	1	6EM5	6	2	6X8A
1	1	4BC8	2	1	6AH4GT	2	1	6BZ7	2	1	6EM7	2	2	7AU7
—	1	4BN6	3	2	6AH6	4	2	6C4	2	1	6ER5	—	1	7EY6
1	1	4BQ7A	1	1	6AK5	73	3	6CB6	2	1	6ES8	1	1	8AW8A
—	1	4BU8	35	2	6AL5	2	2	6CD6GA	—	1	6ET7	—	1	8BA8A
3	2	4BZ6	5	2	6AM8A	2	1	6CF6	—	1	6EU8	2	1	8BQ5
—	1	4CB6	4	2	6AN8A	32	3	6CG7	—	1	6EV5	1	1	8CG7
—	1	4CS6	17	2	6AQ5A	8	2	6CG8A	3	1	6EW6	—	1	8CX8
—	1	4DE6	3	2	6AS5	1	1	6CL6	—	1	6EW7	—	1	8EB8
—	1	4DT6	1	1	6AS8	1	1	6CL8A	—	1	6FD7	—	1	8EM5
—	1	4EH7	2	1	6AT6	—	1	6CM6	2	1	6FH5	—	1	8ET7
—	1	4EJ7	1	1	6AT8A	5	2	6CM7	—	1	6FG7	—	1	8FQ7
—	1	4ES8	5	2	6AU4GTA	2	1	6CN7	—	1	6FM8	—	1	8GN8
—	1	4EW6	62	2	6AU6	—	1	6CQ4	—	1	6FQ5	1	1	9AU7
—	1	4GS8	3	2	6AU8A	2	1	6CQ8	—	1	6FQ7	—	1	9BR7
2	1	5AM8	1	1	6AV5GTA	3	2	6CS6	—	1	6FS5	2	1	10DE7
1	1	5AN8	9	2	6AV6	—	1	6CS7	—	1	6FV6	—	1	10EG7
6	2	5AQ5	14	2	6AW8A	2	1	6CU5	—	1	6FV8	—	1	10EM7
—	1											2	1	25L6GT

FIRST CHOICE WITH SERVICE TECHNICIANS . . . EVERYWHERE!

THERE IS ONLY ONE

MINIATURIZED **ELMENCO** DIPPED MYLAR* - PAPER CAPACITOR

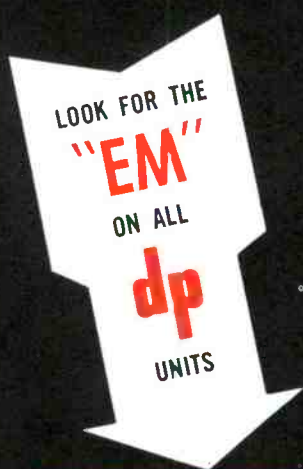

ASK FOR ELMENCO

*don't accept
substitutes
or
imitations!*

- OPERATES AT 125°C.
WITHOUT DERATING
- STANDARD TOLERANCE
±10%
- MISSILE RELIABILITY
- COMPLETELY MOISTURE
PROOF
- UP TO 50% SMALLER
THAN OTHER TYPES

* Dupont Reg. Trademark



**OVER 54,000,000
SOLD IN LESS
THAN 2 YEARS**

**IS PROOF POSITIVE
OF THE UNIVERSAL
ACCEPTANCE OF
ELMENCO dp
DIPPED MYLAR-PAPER
CAPACITORS**



ARCO electronics inc.

Community Drive, Great Neck, New York • Branches: Dallas 7, Los Angeles 35

Available at every REPUTABLE
distributor throughout the country!

Now being used in millions of
television sets, radios, phono-
graphs, electronic circuitry and
military applications.

Write for Catalog dp 110.

PHILCO® PARTNERSHIP BONUS PARADE



FREE OFFERS

We are celebrating 31 years of cooperation between Philco and the Independent Service Dealer with even better FREE OFFERS than ever before. Remember . . . Philco offers you these free gifts with your total purchase . . . Tubes, Parts, and Accessories!

Once in a Lifetime Offer! Imported White Cashmere Sweater with Genuine MINK Shawl Collar

Extravagantly trimmed with wide shawl collar of light Autumn Haze, dark Autumn Haze or white Ranch Mink! 100% full fashioned cashmere cardigan. Rhinestone button on front, cuffs. Sizes 34 to 40.

FREE

with your purchase of \$1200 worth of Philco Tubes, Parts, Accessories



AD #3923

HALLMARK

or Plain
(AD #3934)



With Initial
(AD #3935)

Men's Genuine Jet Black ONYX 10K Solid Gold Ring

A most elegant style that every man would be proud to wear. Plain top or initial in gold.

FREE

with your purchase of \$250 worth of Philco Tubes, Parts, Accessories



AD #3920

Men's Zipper Jacket

32" length, water repellent, quilt lined. Knit collar, cuffs, pocket welts. "Natural" color, 34 to 46.

FREE

with purchase of \$200 worth of Philco Tubes, Parts, Accessories



AD #3931

Men's HELBROS Calendar Watch

FREE with your purchase of \$300 worth of Philco Tubes, Parts, Accessories

AD #3922

LOOK! Sterling Silver Base TABLE LIGHTER

FREE with purchase of \$60 worth of Philco Tubes, Parts, Accessories



ALL OFFERS GOOD UNTIL DECEMBER 15, 1961

FREE OFFERS

Climb on the Bandwagon . . . Join the Parade!
Get Your Share of These Terrific FREE OFFERS . . .

Now . . . Your Total Order . . . Tubes, Parts, Accessories . . . Is Credited toward the FREE Items You Want!



HAMILTON-COSCO

Folding Table and Chair Set

Upholstered metal table, contour back upholstered chairs. Two tone, Tan frame, Mocha fabric.

Table Only (AD #3771)

FREE with \$110 order

2 Bridge Chairs (AD #3772)

FREE with \$170 order

FREE

Complete 5-Pc. Set with your purchase of \$425 worth of Philco Tubes, Parts, Accessories

AD #3785

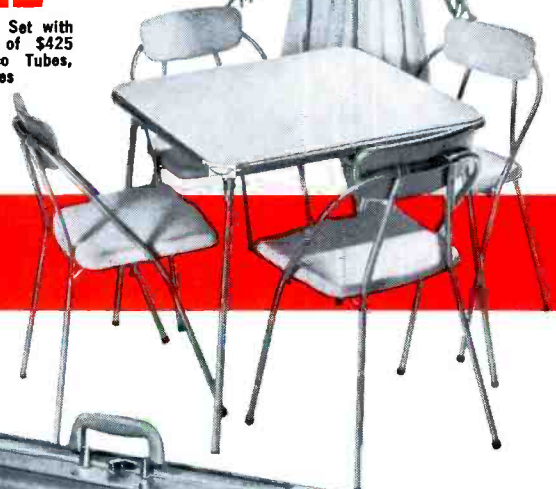

Million Miler Men's and Ladies' LUGGAGE

Solid, seamless, scuff-proof. Weather resistant U.S. Royalite, fiberglass reinforced. Feather-weight, aluminum dust-proof closure.

FREE with your purchases of Philco Tubes, Parts, Accessories

FOR MEN

COMPANION
AD #3757 . . . 21" . . . FREE with \$245 order

TWO SUITER
AD #3756 . . . 24" . . . FREE with \$375 order

THREE SUITER
AD #3755 . . . 26" . . . FREE with \$425 order

FOR WOMEN

TRAIN CASE
AD #3759 . . . 14" . . . FREE with \$245 order

ROUND HATBOX
AD #3763 . . . 16" . . . FREE with \$225 order

OVERNIGHT CASE
AD #3760 . . . 21" . . . FREE with \$245 order

WARDROBE
AD #3764 . . . 24" . . . FREE with \$375 order

PULLMAN
AD #3761 . . . 26" . . . FREE with \$375 order



Million Miler Air Exec ATTACHE CASE

18" x 14" x 5".
Removable file,
removable desk.

FREE

with purchase of \$245 worth of Philco Tubes, Parts, Accessories

AD #3758



AD #3930

Las Vegas Executive Game Chest

10½" Roulette Wheel, Bowling Dice Game, Dice, Dominoes, Chess, Checkers, Chips, Cards, Horse Race Game, Chess Board, directions and carrying case.

FREE

with purchase of \$150 worth of Philco Tubes, Parts, Accessories

Genuine ONEIDA Stainless Flatware

FREE

with your purchase of \$300 worth of Philco Tubes, Parts, Accessories



AD #3927



Tom Thumb Toy Typewriter

FREE

with your purchase of \$200 worth of Philco Tubes, Parts, Accessories

AD #3929

Sturdy Plastic BOWLING BAG

FREE

with purchase of \$70 worth of Philco Tubes, Parts, Accessories



AD #3919

SEE YOUR PHILCO DISTRIBUTOR

PAINLESS TV

Many servicemen approach an alignment job with about as much eagerness as a small boy going to the dentist. Thus, poor alignment of TV sets is a widespread condition which goes largely uncorrected. Considering the many phases of receiver operation that can suffer from misalignment, this situation is not very complimentary to the TV service industry.

The problem is aggravated by the fact that customers are often not overcritical of picture quality, although they can be (and are) quite critical otherwise. There is no reason why servicemen must accept this attitude at face value; instead, they should recognize that they are far better qualified than their customers to judge picture quality and decide whether realignment is needed. Even though customers may not specifically complain about picture quality, they are able to recognize and appreciate the improved picture which realignment can provide.

In fairness to servicemen, it



(A) IF bandwidth of 3.5 mc.



(C) IF bandwidth of 2.75 mc.

should be mentioned that signs of poor alignment seen in actual practice are not always as readily apparent as they are in textbook examples.

Visible Symptoms

Live telecasts and videotaped shows are the only types of regular programs which lend themselves well to judging the need for alignment. Other types of broadcasts, particularly films, are likely to contain smears or other defects which make them unreliable for indicating whether or not the bandwidth is normal. Of course, a test pattern—if available—is by far the most useful transmission for this purpose. By the way, the photos in Fig. 1 were taken early in the morning, the only time I can tune in a broadcast test pattern. If you're lucky enough to have a pattern available during working hours, or if you own a piece of test equipment that enables you to generate your own test pattern at will, you have a distinct advantage in checking the alignment



(B) Enlarged portion of Fig. 1A.



(D) Enlarged portion of Fig. 1C.

Fig. 1. Effect of bandwidth on picture detail.

of receivers that go through your shop.

My purpose in presenting Fig. 1 is to demonstrate the value of test patterns in judging the IF bandpass and picture quality of TV sets. Part A of this figure shows the result of aligning a receiver to its correct 3.5-mc bandwidth. Fig. 1B is an enlargement of the vertical wedge in this pattern, to show the sharply-defined video information at the small end of the wedge. When I narrowed the bandpass of an identical receiver to 2.75 mc, it presented the "softer" picture shown in Fig. 1C, with high-frequency information blurred as illustrated in Fig. 1D. Incidentally, the antenna used with these sets gave a slight ghost that showed up on the test patterns, but was not very objectionable on programs.

Several persons were "view-tested" using these two sets. First, the narrow-bandpass receiver was tuned to a regular program, and nobody complained about picture quality. However, when both receivers were operated side by side, the same viewers readily noted and approved of the sharper pictures on the properly-aligned receiver. This goes to show that the average viewer is not a good judge of picture quality except when viewing on a comparative basis. Generally, it takes a fairly bad case of misalignment, such as the severe ringing in Fig. 2, to prompt a customer complaint.

Audible Symptoms

Set owners seem to be more sensitive to sound troubles caused by faulty alignment than they are to the corresponding picture troubles. In early split-sound receivers in particular, it was relatively easy to determine the need for realignment by noticing the poor tracking

ALIGNMENT

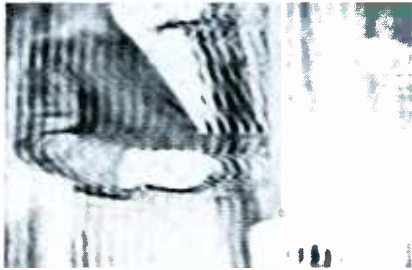

Fig. 2. Severe ringing—one alignment fault customers will complain about.

between sound and picture. Even so, the once-frequent complaint, "If I tune for good sound I get a poor picture, and I lose the sound if I tune for a better picture," was not always accurate. Sometimes what the customer called a "better picture" was only a more contrasty picture with rather poor definition.

The drift-proof 4.5-mc sound IF in intercarrier receivers provides greater leeway in fine-tuning adjustment, and thus makes these sets less prone to the complaint of poor tracking. This is true even on receivers having poor alignment. However, less than normal bandwidth can still cause a complaint of weak sound, as in one Motorola



(A) Rounding—bandpass too narrow.



(B) Ringing—bandpass too wide.



(C) Bandpass normal.

Fig. 3. Bandwidth affects sync pulse.

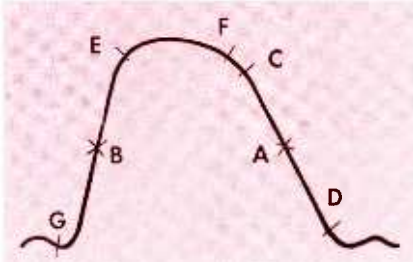

Fig. 4. Seven major points universally used to evaluate IF response curves.

TS-537 I serviced not long ago. The picture seemed acceptable even when examined critically. After other troubleshooting procedures failed, I decided to look at the IF bandpass. It was found to be less than 2.5 mc at the "6 db down" points on the curve. Realigning the IF strip to its normal 3.5-mc bandwidth not only cleared up the sound, but also gave improved picture clarity I had not suspected was lacking.

More on Diagnosis

Visible symptoms of misalignment are not limited to smear and ringing, but extend to other troubles not ordinarily associated with alignment deficiencies. A good example of this is critical sync, which can be due to attenuation of low video frequencies when the picture carrier is too low on the IF-bandpass curve.

Sometimes incorrect bandwidth is not caused by simple misalignment, but by component defects in the RF-IF stages. This bears out the importance of thoroughly checking the condition of these circuits before attempting to align a set. Here are several examples of troubles which caused suspicions of misalignment:

1. Severe ringing in a Silvertone, due to a bad 6CB6 in the third video IF stage.

2. Smear in an RCA KCS47, due to a shorted screen-bypass capaci-

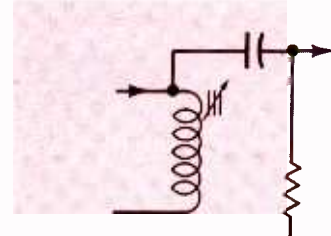

Fig. 6. Tuned coil and capacitor give same results as bifilar transformer.

tor in the second IF.

3. A classic condition of poor tracking between sound and picture in a Motorola. When the fine tuning was adjusted to bring in good sound, the picture broke into various patterns (herringbone, ringing, or unsteady sync); but the picture was faultless when the sound was tuned out. This trouble was eventually found to be caused by an open screen bypass in the sound IF circuit.

The same kind of defects as those created by poor alignment can also result from faults in the video am-

• Please turn to page 80

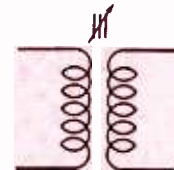

(A) Bifilar-wound transformer.

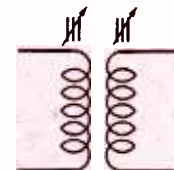

(B) Overcoupled transformer.

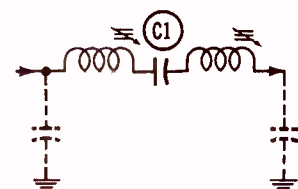

(C) Series-tuned network.

Fig. 5. Basic IF coupling networks.

PLANNING

What kind of an intercom system would you plan for a home, farm, factory, office, or store? Obviously, there is no universal system that automatically fits the needs of such a wide variety of applications. However, all systems have one common purpose—adequate communications between two or more points. Therefore, if you are well informed about what's available in the way of intercom equipment, and if you check to see what's expected of a proposed system, you'll experience little difficulty in planning a suitable installation.

Here are suggested layouts for five typical intercom systems. After studying them carefully, you will see they can easily be adapted to fit practically any intercom job.

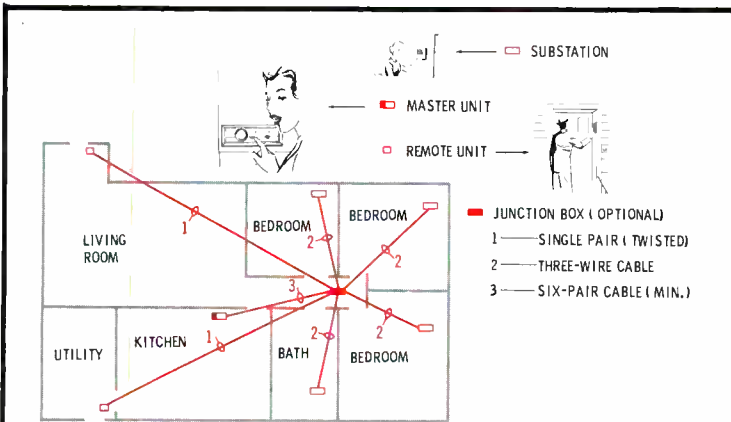

A home intercom may be a simple two-station system for answering the door, remote baby-sitting, or calling the family to dinner. On the other hand, it may be a larger system that pipes music to every room, in addition to permitting two-way conversations. The kitchen is a favorite location for the master unit, because it's the normal center of activity. When you're wiring a system into a new house, it's advisable to allow for future expansion by running wires to the basement, attic, garage, etc., before walls are finished.

When installing wireless units that simply plug into the AC line, connect a .1- to .5-mfd, 600-volt capacitor between the two fused ("hot") lines of the 220-volt entrance lead. This will assure operation on any branch circuit.

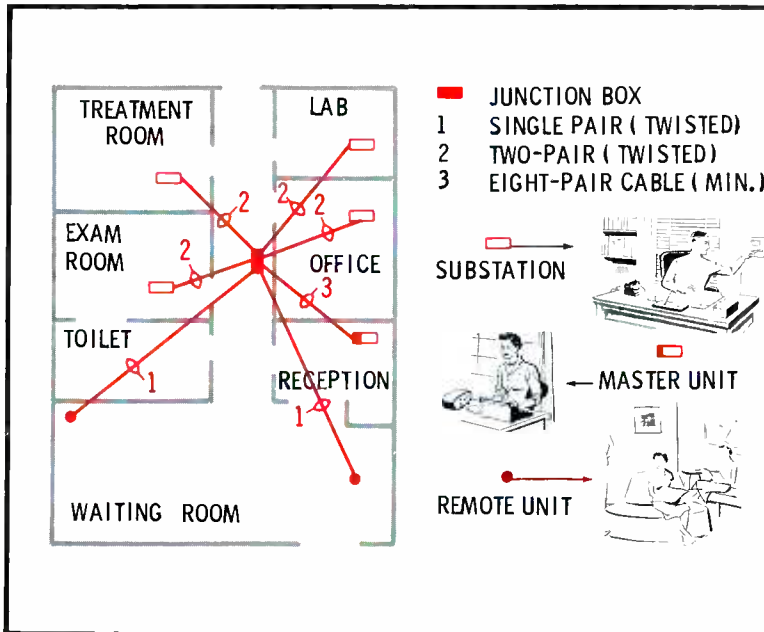

Doctors, dentists, realtors, and other professional people generally require an office-intercom setup similar to this. The equipment basically consists of a master unit operated by a receptionist, several substations equipped with press-to-talk switches for two-way communications, and a couple of extra remote speakers to carry music and announcements to a waiting room. Selective calling and privacy are important; therefore, equipment should be chosen accordingly.

If the office is leased or rented, you may not be permitted to install leads within walls. In this case, the system can be wired through decorative conduit along wall moldings and in other inconspicuous places. Additional costs for such material must, of course, be figured into your original estimate.

For many retail stores such as this supermarket, an intercom system is no longer a luxury, but a necessity. This example uses a combination of push-button phones and "talk-back" speakers, plus a background-music and paging system for the entire store. Intercom phones are located at key points throughout the building to provide private communications between any two points. Speakers in the stock room can either reproduce or pick up sound; their operation is controlled in the office.

This type of system also finds applications in banks, bowling alleys, and many other places of business. As an installation hint, always use coded leads to insure proper phasing of the speakers.

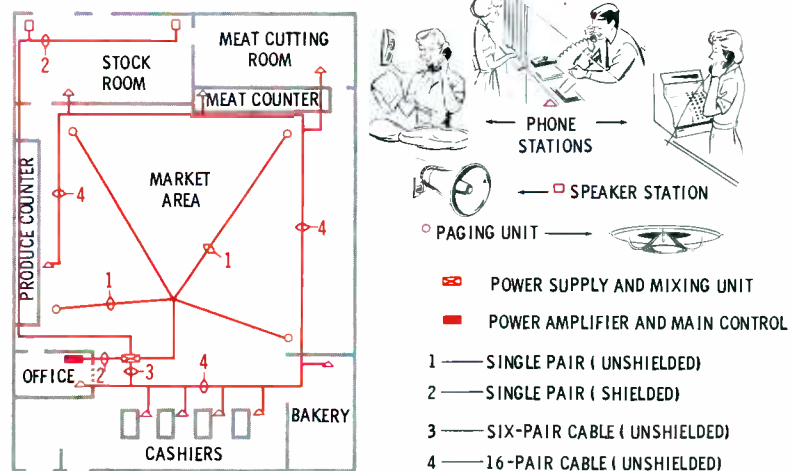

Intercom Installations

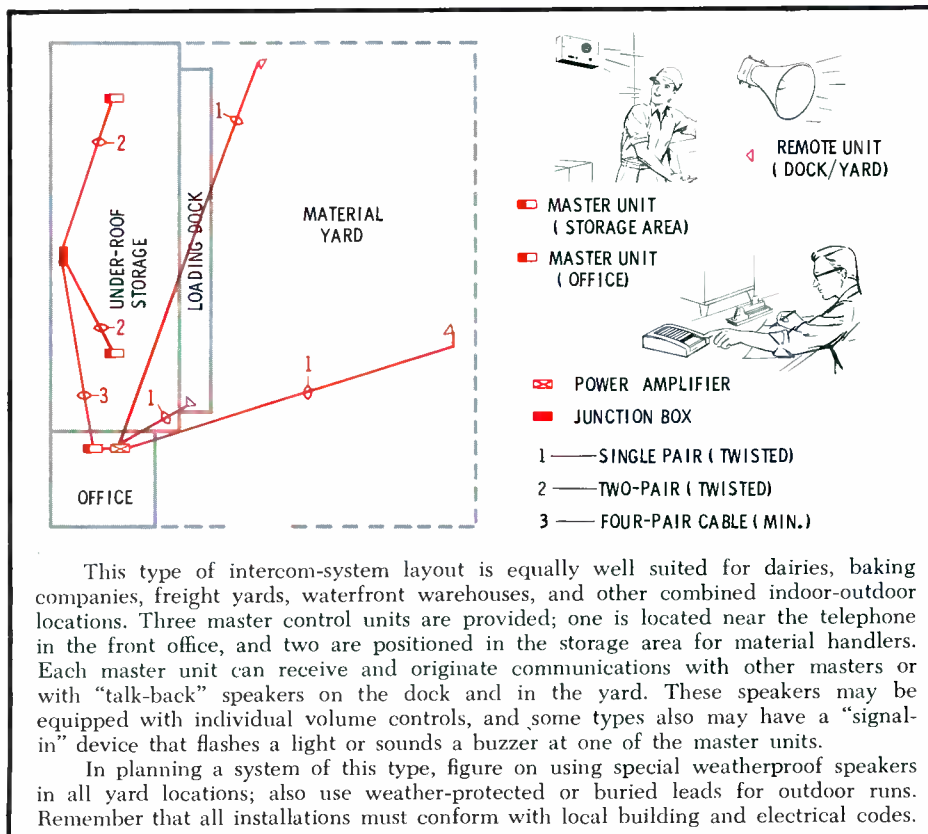
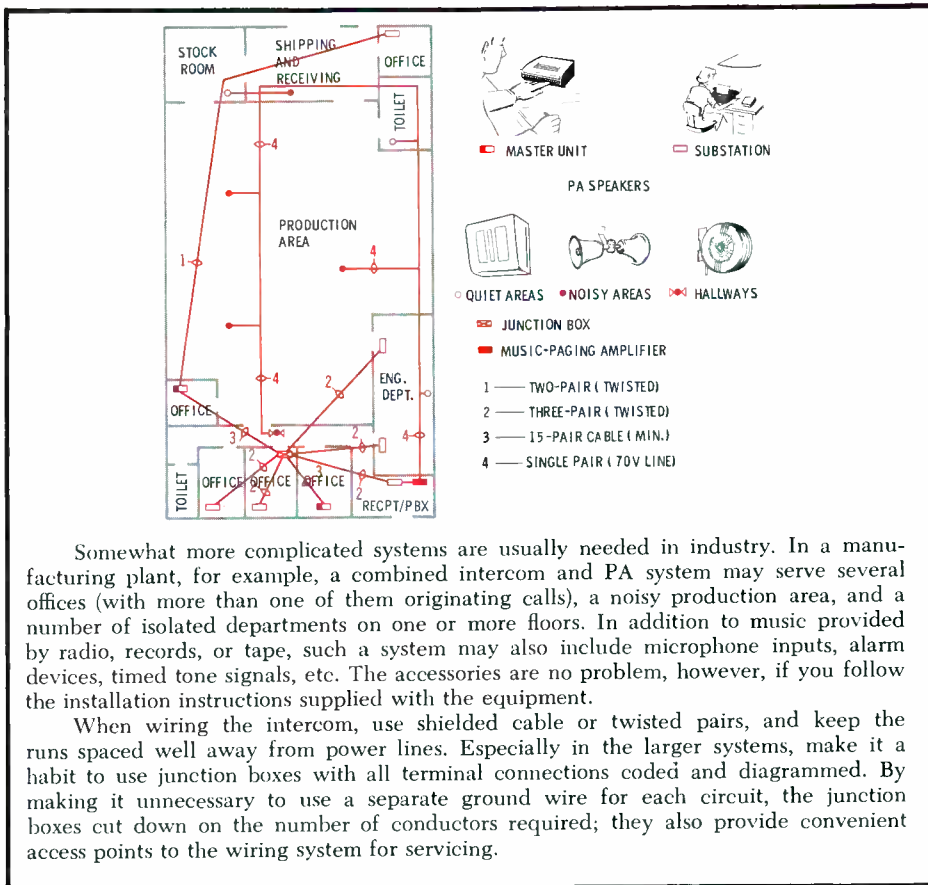

ITEM CHECK LIST

INTERCOM EQUIPMENT

- MASTERS
- SLAVES
- REMOTES

ACCESSORIES

- POWER AMPLIFIERS
- MIXING UNITS
- RADIOS—AM/FM
- PHONO OR TAPE RECORDER
- MICROPHONES
- PREAMPS
- AUTOMATIC TIMERS
- TONE AND VOLUME CONTROLS
- POWER MONITORS
- SPECIAL SWITCHES
- SIGNAL OR ALARM DEVICES

PA EQUIPMENT

- SPEAKERS
- MATCHING TRANS.
- BAFFLES AND ENCLOSURES

INSTALLATION MATERIAL

- WIRE AND CABLE
- FASTENERS OR CONDUIT
- JUNCTION BOXES
- PANELS AND GRILLES
- MISC. HARDWARE

LABOR CHECK LIST

ESTIMATING TIME

- SURVEY
- CUSTOMER CONSULTATION
- MATERIAL LIST
- FLOOR-PLAN DIAGRAM

INSTALLATION TIME

- SECURING MATERIAL
- POSITIONING EQUIPMENT
- MOUNTING SPEAKERS
- RUNNING CABLE
- WIRING SYSTEM
- CODING TERMINALS

MISC. TIME

- WIRING DIAGRAM
- OPERATIONAL CHECK
- MATERIAL AND LABOR INVOICE

Schoolroom TV Takes to the Air

The serviceman's role in equipping schools to receive TV lessons broadcast from an airplane . . .
by Jack Beaver

The instructional television program now operating from a transmitter 26,000 feet up in an airplane bids fair to teach TV technicians some new tricks in UHF broadcast pickup. Whoever heard of UHF-TV programming on a consistent day-to-day basis at a 175-mile range?

A little history of this project is important, and a little forecast might also be interesting. The whole thing started with the famous "Stratovision" experiments of the late '40's, when TV broadcasts were made from a B-17 flying over

the eastern Pennsylvania and Maryland countryside at heights up to 30,000 feet. TV watchers of that time reported snow-free pictures at ranges up to 225 miles.

In view of this experience, a group of forward-thinking educators, using Ford Foundation funds and aided by the Westinghouse "Stratovision" experience, proceeded with a plan to broadcast instructional television from an aircraft flying over east-central Indiana. The Midwest Program on Airborne Television Instruction (MPATI) utilizes two DC-6B air-

planes as flying television stations, each transmitting on two UHF channels, 72 and 76. One is flown in a figure-8 pattern ("orbited") over Montpelier, Ind., while the other is maintained as a standby.

The project became a source of great interest to television antenna, set, and distribution-system makers, and much cooperation was extended in equipping schools to pick up the early test phases of the program. This fall marks the first full schedule of broadcasts.

The usual reaction to this story is, "Wow, what an expensive way to mount a transmitting antenna!" In actuality, the cost of covering the same area by relays and tower-mounted transmitting antennas would be a great deal more—the flying transmitters are the most economical!

Let's look a little into the future: Educators in other parts of the country are watching this development with intense interest. If it goes as planned, other operations will follow; the economics of the system force it. The interest of the 13,000 schools in the present coverage area (Fig. 1) is high, and great sums of money have been spent in equipping the schools with reception gear. This is a happy precursor of what can happen elsewhere—and an omen of what will be required of TV technicians in the way of know-how.

The problems of reception from this flying transmitter are somewhat different from those involving a fixed, ground-based transmitter. The nature of the problems also varies greatly according to the range at which signals are received. Some special difficulties are caused by the aircraft's motion, which is a figure-8

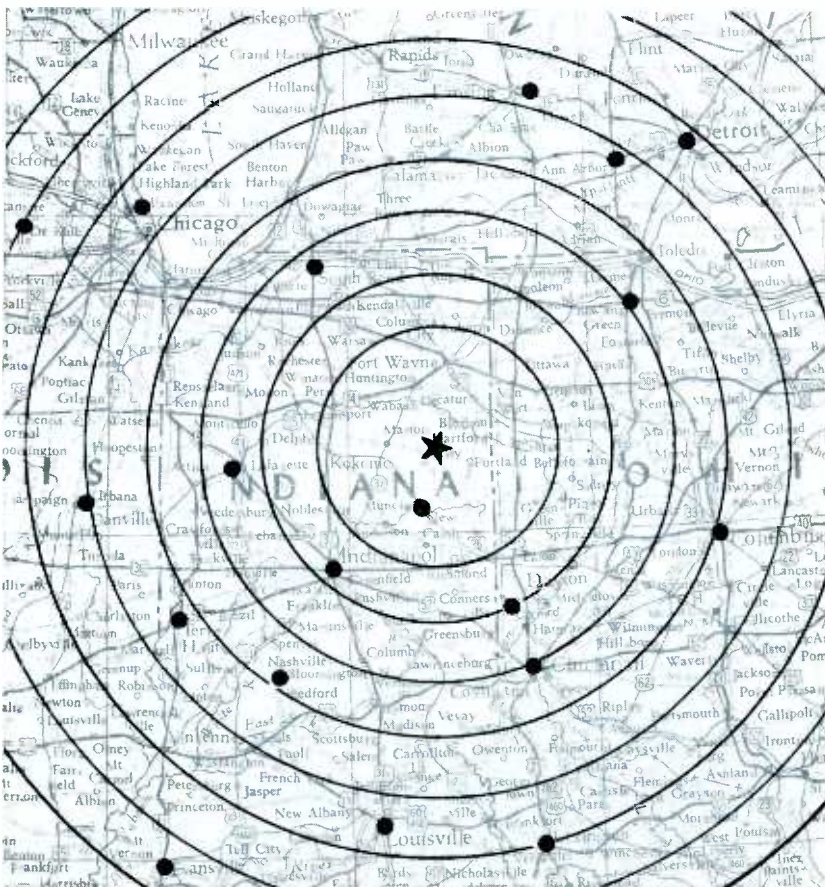

Fig. 1. Signals from flying TV transmitter are reaching most of this area.

pattern, about 20 miles long from top to bottom of the 8, and usually flown so that the 8 heads into the prevailing wind. Fig. 2 illustrates the different conditions of reception that may exist at varying ranges. The drawing is deliberately out of scale, in order to point up the different angles. For example, the aircraft is about five miles over the surface of the earth, but the antenna at point D is 200 miles away from the center of the orbit.

The four locations illustrated in Fig. 2 cover almost every practical difference in situation. Although approximate ranges are assigned to each category of reception, these figures do not represent hard and fast rules. To illustrate this point, the conditions existing at D in Fig. 1 may quite easily occur within 50 miles of the aircraft, if the receiving site happens to be on the "wrong" side of a hill so that the antenna can't "see" the aircraft, or can see it during only part of its orbit. Conversely, point C could have point-B conditions if C were on top of a good-sized hill or building. Therefore, the only accurate way to "pigeonhole" a given location into one of the four reception categories is to check the signal actually received at that location.

The Technician's Part

Once the installer of a receiving system knows what type of reception he is dealing with, he can choose components that will give the desired performance in that situation.

Antennas are first on the list. Installations out in the fringes, 150 to 200 miles away from the aircraft, demand high-gain antennas—perhaps parabolic types with apertures (reflector dimensions) of six feet or even larger. High towers may be needed; in this case, it is important to check the building and safety codes carefully and watch for FAA lighting requirements. This is the kind of installation you'll run into at point D of Fig. 2.

Point C calls for somewhat the same kind of installation, but the signals are likely to be much more variable, since the antenna may have line-of-sight when the airplane is on the near side of its orbit and be below line-of-sight when on the far side of the orbit. This will result

COMMON REASONS FOR POOR MPATI RECEPTION

In actual field testing, the following causes of substandard performance have turned up most frequently:

Poor antenna location. Surprisingly, an antenna mounted on a flat school roof has been found to perform better when located on the side away from the airborne transmitter. Many technicians have been unquestioningly choosing the "logical" mounting spot on the side facing the airplane, but an antenna in this location is more likely to pick up signal reflections from the ground or other distant surfaces. This causes ghosting or periodic fading of the signal. A large, flat roof might seem to be a troublesome source of reflections; however, if it is sufficiently close to the antenna, it seems to act as an anti-reflection screen.

This point explains another unusual fact about MPATI antennas: To minimize pickup of reflected signals, the antenna should be no higher than necessary to obtain adequate signal strength. Installers are used to "reaching up" for ground-based TV signals, and thus are running into trouble due to excessive antenna height.

Inadequate checking of signal strength. Since UHF-TV field-strength meters are not readily available, the only practical way of evaluating a single-set installation is to observe the picture. However, a more accurate method—using a VHF field-strength meter—is advisable when a complete antenna-distribution system is being installed. The meter is connected to the output of the mast-mounted UHF converter head. Since it is more sensitive than the eye, it can detect slight signal

fluctuations due to the orbiting pattern of the plane. Relative freedom from these fluctuations is more important than high signal strength in assuring good system performance.

Besides its usefulness in judging antenna sites, the field-strength meter provides an accurate way to peak the alignment adjustments in the UHF converter used with the distribution system.

Poor choice of VHF channel for converter output. UHF converters used with distribution systems are available with output on any VHF channel from 2 to 13. Conversions should be carefully selected to avoid co-channel or adjacent-channel interference with nearby commercial VHF stations. For example, channels 2 and 10 are preferred in the Indianapolis area, where stations are broadcasting on channels 4, 6, 8, and 13.

Loose coaxial-cable connections. Careless installation of coax fittings has been at the root of many reception problems. Use of a special crimping tool is recommended for positive results.

Overheated system components. In some cases, distribution amplifiers and related units have been installed in attics of schools. During the warm months, these closed-up spaces (especially ones with flat roofs) often become so hot that the equipment overheats and blows fuses. To prevent future service problems, school officials should be urged to permit installation of components in upper hallways, custodians' closets, and other relatively cool and accessible locations.

in fades every ten minutes or so, depending on the flight pattern.

These conditions will apply at their worst over only a small band of territory, about 10 miles wide. Installations here will require equipment with highly effective automatic gain control.

The area of point B is in continual line of sight, and moderate-

gain antennas such as corner-reflector, dipole-on-screen, and yagi types should suffice. High-gain antennas should be avoided at the nearer end of this range because of their sharp directivity, which may cause signal variations as the plane enters and leaves the major lobe of the antenna pattern. Corner re-

• Please turn to page 68

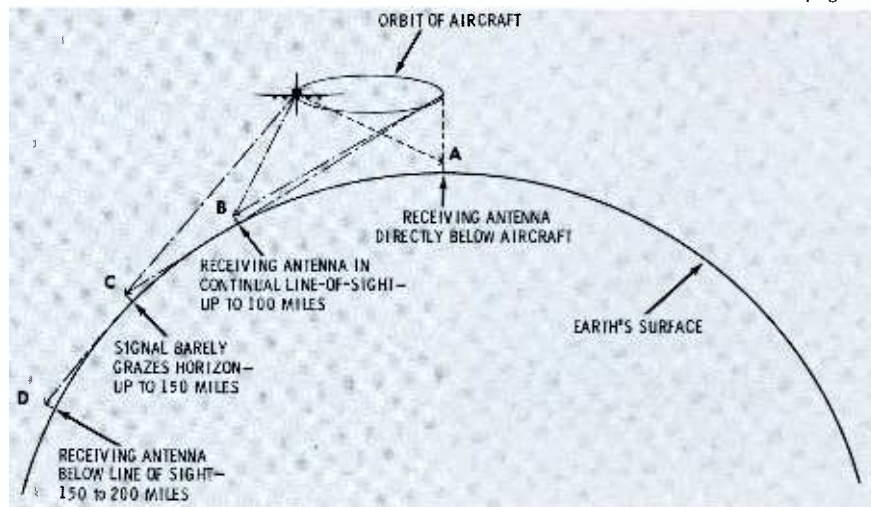

Fig. 2. The four types of receiving sites all present different problems.

tributors. As shown by the examples in Fig. 1, these guides can help you locate a replacement by several different methods. For instance, you can identify the original needle type and its replacement by referring to pictorial illustrations (Fig. 1A). You need only know the phonograph manufacturer and model number in another reference method (Fig. 1B). A replacement can also be found if the original cartridge manufacturer and model is known (Fig. 1C); or, another needle manufacturer's type can be cross-referenced to the particular brand desired (Fig. 1D). In still another method, the needle may be identified by pictures of various pickup heads (Fig. 1E).

Some needle manufacturers package kits that include a selected group of popular types. Others make available individual packages for various brand-name phonos such as G-E, RCA, Webcor, etc. If you don't already have a stock of replacement needles, Chart I lists some of the most popular, fast-selling types which should be included in your selection. Each type is pictured, with replacement numbers listed for the leading needle producers.

Replacement Hints

The needle replacement must fit the cartridge connection, and it must have the proper tip size (normally 3 mils for standard 78's, 1 mil for microgroove LP's, .7 mil for stereo records, and 2.5 mils for all-purpose use); furthermore, its shape must match that of the original so it will meet the record grooves at the proper angle and maintain a certain tone-arm height. In addition, the replacement may require dual tips or a special protective guard. Its shank may also have to be extra sturdy—especially if the tone arm and cartridge are exceptionally heavy. Some needles are not replaceable as such, but are an integral part of the cartridge; in this case, of course, an entire new assembly must be obtained.

Generally, you'll have little trouble removing the original needle and installing a replacement. The old crystal-type cartridges usually have a simple thumbscrew arrangement—although, in the case of a turn-over design, you may have to remove the crystal in order to reach

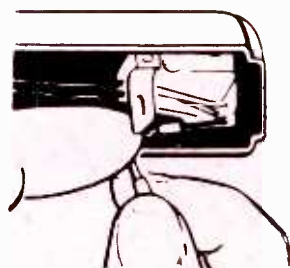

(A) Releasing spring.

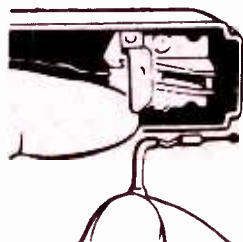

(B) Lifting out needle.

Fig. 2. Spring-clip mounting for Sonotone three-speed turnover needles.

a small set screw holding the two needles. Many ceramic pickups have needles that are merely forced into the cartridge. These so-called friction-held units are easily removed by slipping a knife blade or your fingernail under the heel of the needle shank. A replacement is installed by holding the shank with your fingers and pushing it gently into the cartridge chuck until it seats.

Many needles are held by knurl-head or conventional screws on

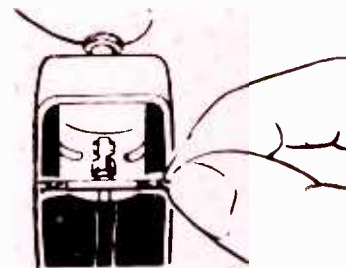

(A) General Electric type.

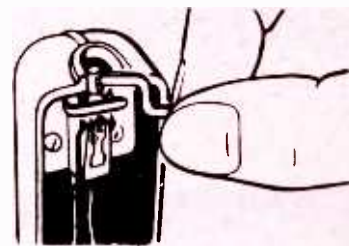

(B) Astatic type.

Fig. 3. The other examples of needles held in place by spring-type mounts.

the underside of the tone arm; however, they are no more effort to change than those found in the old crystal cartridges. If the needle is clip-mounted, you will most likely be able to remove the entire clip and needle with your fingernail. When putting the new needle in, fit the clip assembly into the cartridge slot (usually at the rear) and then snap it into place, making sure the shank tracks with the guide.

Some types, held in by a spring

• Please turn to page 75

Chart I Standard Replacements

ORIGINAL NEEDLE	ASTATIC	DUOTONE	ELECTRO-VOICE	FIDELITONE	JENSEN	PHILCO	QUALITONE	RECOTON	WALCO
	N640-1S	517	3105	A-1	JPS-30LP	325-8199	1317	317	W-30MGS
	N561-1S	560	2902	A-98	M74LP	325-8184	1310	310	W-44MGA
	N350-1S	661	2728	A-179	G-1	325-8156	1418	418	W-68MGS
	N8-1S	594 (RMP)	3000	A-193	CRA-55LP	325-8141	1464	464	W-64MGS
	N302-7S	733	2604	A-229	E-98X	325-8232S	1506	506	W-101STS
	N601-7S	735	3005	A-233	CRA-57X	325-8244S	1504	504	W-104STS
	N7-7S	824	2420	A-267	CRA-55X	325-8253S	1513X	516	W-108STS
	N644	647 (WC-10)	3109	AC-186	JPS-35	325-8194	1427	427	W-35TPS
	N676	737	3212	AC-238	S-71X	325-8246S	1503	503	W-103STSS
	N562	816	2906	AC-253	M77X		1520X	533	W-117STSS
	N676	857	3213	AC-255	S-71X		1522X	522	W107STSS
	91T	698 D/S	76	AC-260	E-37			490SD	W-202TPS



QUICKER
SERVICING

smoothing out the "pie crust"

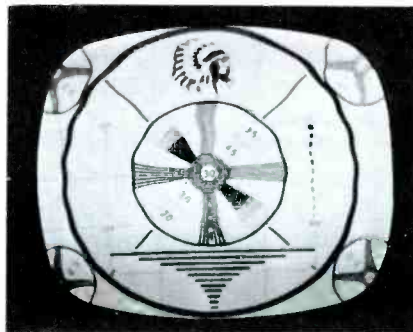
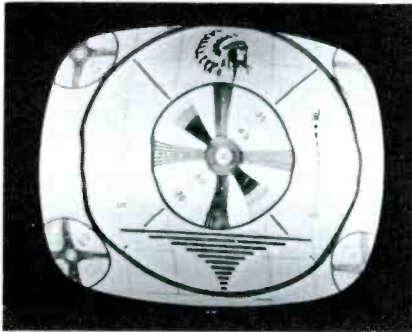

Fig. 1. Which one of these test-pattern photos displays piecrust effect?

It's easy as pie to correct the TV picture trouble known as "piecrust effect"—if you accurately diagnose the condition in the first place. Unfortunately, many servicemen take a wrong turn on this vital first step; they misinterpret the symptom, and end up groping in the dark.

Are you sure you can recognize piecrust effect when you see it? Try your hand at spotting this symptom in Fig. 1. Both test patterns are disturbed by telltale wiggles in vertical lines of the picture; however, only one photo represents the "real thing." The other symptom is due

to a completely different cause. Study both pictures carefully, and look for clues that will tell you which one shows true piecrust distortion.

If you're not sure whether to pick A or B, perhaps a review of troubleshooting hints will help you decide. The wiggles in the picture mean that some of the horizontal lines in the raster have shifted to the left or right of their normal position, so it's logical to look in the horizontal AFC or oscillator circuit for the trouble. Four different types of circuits which can

develop piecrust disturbances are shown in Fig. 2. Naturally, many variations of these circuits are in use, but comments referring to the basic circuits will apply equally well to all related types.

Note the heavy arrows in Fig. 2. These point to the components which can cause piecrust troubles. Look closely, and you'll see that all these parts (other than tubes) are either bypass capacitors or portions of filter circuits. If you clip out and replace all these parts, the trouble should be cured. Whoa, now! This is a crude way to repair a set; furthermore, all your effort will be in vain if the defect isn't a genuine piecrust condition. Remember, certain other troubles can also produce a series of wiggles in the raster. A few examples are improper B+ filtering, heater-cathode leakage in some tube, or even vertical sync or sweep signals seeping through to the horizontal oscillator.

True piecrust effect is distinct from all these other faults. It is most often traceable to a "hunting" action in the horizontal AFC stage, which causes wavering of the control voltage fed to the horizontal oscillator. Another frequent cause is a microphonic AFC or oscillator tube.

Armed with these facts, let's have another look at the test patterns in Fig. 1. Note that A has fewer and more irregular ripples than B. It also displays a slightly darker background at the top and bottom, but you can't always rely on this discoloration as a definite clue—it may not be present in some cases. The relatively large number of ripples in Fig. 1B, which occur at fairly regular intervals, mark this pattern as a true piecrust effect.

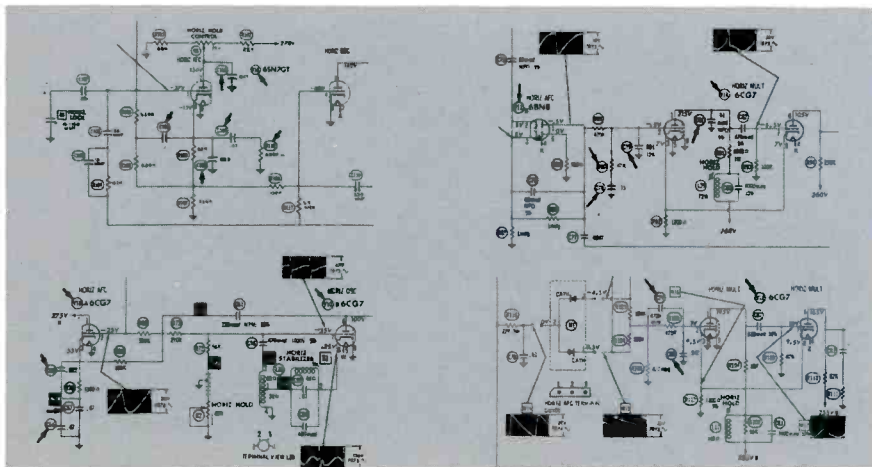

Fig. 2. Heavy arrows point to components which can cause piecrust symptom.

PHOTOFACT world's finest electronic service data now greater than ever!

with dozens of exclusive new features for fastest, easiest, more profitable servicing



COVERS:
 Black & White TV
 Color TV
 AM Radios
 FM Radios
 Transistor Radios
 Auto Radios
 Amplifiers, Tuners
 Recorder Changers
 Tape Recorders



OVER 50,000 LISTINGS: Only service data of its kind—prepared from analysis of the actual equipment. Complete, uniform, accurate. Over 21,000,000 PHOTOFACT Sets now in use! If you're not using PHOTOFACT, you're not realizing your full earning power. So get the proof—try PHOTOFACT on any job—see how much time you save, how much more you can earn daily! Your Parts Distributor has the PHOTOFACT Folder Sets you need. Have *all* the help you'll ever want for greater servicing success and bigger earnings!

FAMOUS "STANDARD NOTATION" SCHEMATICS

- Uniform symbols in each schematic; same circuit layout form each time
- Voltages at tube pins and test points
- Waveforms at appropriate points on TV schematics
- "CircuitTrace" identification numbers for printed circuits
- Schematic items keyed to chassis photos and parts lists
- Special capacitor and resistor ratings
- Coil and transformer color codes or terminal identification

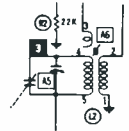

- Test points labeled
- Special currents shown (B+, horizontal output cathode, horizontal output screen)

- Alignment adjustments and test points labeled
- Tube functions shown
- Control and switch functions shown
- Switch sequence indicated
- Power supply "sources" shown
- Fuse ratings indicated
- Coil resistance over 1 ohm shown
- Coding of electrolytic capacitors shown

REPLACEMENT PARTS LISTS



- Lists standard, locally available replacement parts
- Includes notes for special installation or other considerations
- Includes ratings and/or measured values for assisting in selection of replacement parts
- All parts keyed to chassis photos and schematics for quick reference

TUBE PLACEMENT DIAGRAMS



- Shows tube types and functions; top and bottom views shown
- Includes filament connections in series string
- Indicates TV sound and sync paths
- Tube failure check charts included
- Shows blank pin or locating key on each tube
- Includes fuse locations and ratings.

ALIGNMENT INSTRUCTIONS



- Gives step-by-step easy-to-follow alignment data
- Procedure makes use of standard service-type equipment
- Alignment frequencies are shown on chassis photos near adjustment number—adjustments are keyed to schematic and photos

"CIRCUITTRACE" FEATURE



- Invaluable printed board servicing aid—indicates points on board photo and schematic for quick, easy measurement of components, or test locations

FULL PHOTO COVERAGE



- All chassis views are shown in actual photographs
- All parts are numbered and keyed to the schematic and parts lists
- Test and alignment points indicated

FIELD SERVICE NOTES

- Outlines procedure for "in the home" adjustments
- Gives hints on quick access to pertinent adjustments, safety glass removal, etc.

"BONUS" FEATURES

- Disassembly instructions
- Dial cord diagrams
- Record changer and tape recorder "exploded views" for easy mechanical parts replacement or service

"PLUS" ADVANTAGES

- ★ Citizens Band Radio coverage
- ★ Tube Test data—provides setting for testing new tubes
- ★ Color TV Course "Bonus" beginning in Set No. 541
- ★ Eligibility for membership in "PEET" with ownership of a PHOTOFACT Library

SEND FOR YOUR PHOTOFACT INDEX NOW!

FREE

ONLY \$10 DOWN puts the complete PHOTOFACT Library in your shop—and you have up to 30 months to pay. Right now—keep up with the industry—sign up for a Standing Order Subscription to PHOTOFACT! See your Sams distributor for full details on a Library or Standing Order purchase!

FREE! VALUABLE PHOTOFACT INDEX

YOUR GUIDE TO OVER 50,000 TV, Radio, Electronic Listings! Send for it today! Your guide to virtually every model produced since 1946. Helps you locate the proper PHOTOFACT Folder you need to solve any service problem in any model. Send the coupon today for your FREE COPY of the latest PHOTOFACT Index to the service data you need!



HOWARD W. SAMS & CO., INC.

Howard W. Sams & Co., Inc., Dept. 7-K1
 1724 E. 38th St., Indianapolis 6, Ind.

- Send FREE Photofact Cumulative Index
- Send full information on: Easy Buy Plan
 Standing Order Subscription "Peet" Program

Shop Name _____
 Attn.: _____
 Address _____
 City _____ Zone _____ State _____

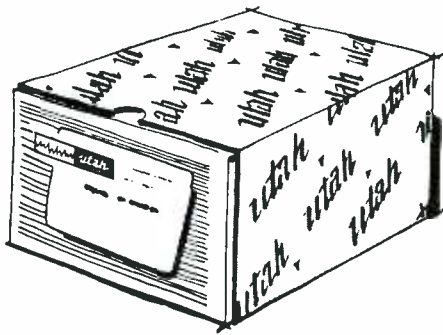

WHY PACK ONLY ONE SPEAKER TO A BOX?

A speaker is a delicate precision-built instrument which should be protected from dust and physical abuse.

By single-packing speakers in custom-fitted reshippable cartons, Utah actually saves the distributor time and money. There's no need for repacking. Clearly labeled, single-packed speakers make inventory control easy for both the distributor and serviceman.

Most important, Utah can guarantee factory tested performance of every speaker on delivery. This adds up to customer satisfaction all down the line.

Utah believes everyone benefits from single-packing—consumer, serviceman, distributor—and the electronics industry.



HUNTINGTON, INDIANA

If you have trouble identifying this symptom on an actual receiver, try switching off channel and looking for evidence of 60- or 120-cycle hum. (For descriptions of this trouble refer to last month's *Quicker Servicing* column, "Track Down That Visible Hum.") Also change the tubes in the horizontal AFC and oscillator stages. If you're fairly certain by this time that you're dealing with a piecrust symptom, grab a capacitor and resistor substitution unit, and jumper the parts pointed out in Fig. 2. There's no need to cut them loose for testing, since an open component is usually at the root of a piecrust problem. When you hit the faulty part, the symptom should immediately disappear.

Make sure of the visual symptom and then jumper a handful of components in the horizontal AFC and oscillator circuits—not even Betty Crocker knows a simpler way to trim off a piecrust!



Power Resistors On Tap

It isn't at all unusual for a serviceman to encounter an open resistor of fairly high wattage. Filament- and screen-dropping resistors and B+ dividers seem to have a strange knack of opening. The *Big 20* power-resistor substitution unit produced by Sencore, Inc., of Addison, Illinois comes in handy at such times. It provides multiples of 1, 10, 100, and 1000 times the following resistance values: 2.5, 5, 7.5, 10, and 15 ohms. The unit is rated at 20 watts on all settings—high enough to allow safe substitution for any standard power resistor used in a radio or TV receiver.

After the two switches of the *Big 20* are set to the desired value,

the permanently-attached test leads can be connected across a suspected open resistor, and the equipment turned on to see if the substitution unit restores normal operation. Incidentally, the clips are well insulated, so they can be attached or removed from the circuit while the power is on. If the value of the suspected resistor is unknown, the *Big 20* can be set to one of the higher ranges and connected to the circuit; then, various values can be selected during operation to determine the size of resistor needed to restore normal circuit voltages.



Rotator Troubleshooter

Want a slick way to isolate the trouble area in an antenna-rotator system? Channel Master Corp. of Ellenville, N.Y. has developed an automatic control unit, Model CM-9526, that can be substituted for any popular type of rotator control box. If a "no rotation" symptom can be corrected by temporarily installing the CM-9526, the trouble is obviously in the original control unit; if the trouble still remains, further checking of the rotator and cable is necessary.

The CM-9526 is designed for 1-rpm operation; therefore, if it is installed in a 2-rpm system, only one-half circle of rotation can be obtained. However, this is sufficient for troubleshooting purposes.

If the unit restores a 1-rpm system to normal operation, it can be left as a permanent replacement for the original control box. It can also be used to convert any 1-rpm manual-type rotator system to automatic operation. ▲

Wake Up



A new day is dawning in electronics.

Transistors are here to stay... they are now being used everywhere; in radio, television, Hi-Fi, intercom, and in nearly all new electronic equipment...

Why put off transistor circuit servicing any longer... there's gold in them thar hills. But you must be equipped to do the job fast and efficiently. Here are the tools that you will need.



NEW SENCORE TRANSI-MASTER

This Tester will analyze the entire circuit in minutes and test transistors in-circuit or out of circuit. Here is how you can pin point troubles step by step with the TR110.

First, check the batteries with the 0 to 12 volt meter. If the batteries are O.K., check the current drain with the 0 to 50 milliamp meter. A special probe is provided so that you do not need to break the circuit. Excessive current indicates a short; low current indicates an open stage or cracked board. All PF schematics indicate average current.

If trouble is not located by now, isolate the trouble to a specific stage by touching the output of the harmonic generator to the base of each transistor and note spot where sound from speaker (or scope where no speaker is used) stops or becomes weak. The generator becomes a sine wave generator for audio stages to help find distortion.

If trouble points to a transistor, check it in a jiffy with the exclusive in-circuit power oscillator check provided by the TR110. A special probe is also provided for this.

If the transistor checks bad in-circuit, remove it and give it an out of circuit check with the oscillator check or the more accurate DC check.

The DC check is provided for comparison reasons, experimental or engineering work and to match transistors in audio output stages. Beta (current gain) is read direct or on a good-bad scale for service work.

DEALER NET. ONLY **\$49.50**



Tests all transistors in-circuit or out-of-circuit

Model TR110

It's a COMPLETE TRANSISTOR TESTER

- SIGNAL TRACER • VOLTMETER
- BATTERY TESTER • MILLIAMMETER



NEW SENCORE TRANSISTOR AND DIODE CHECKER

Here is a low cost tester that has become America's favorite. The TR115 provides the same DC out of circuit checks as the TR110; leakage and current gain. Beta (circuit gain) can also be read direct or as good or bad. Opens or shorts in the transistor are spotted in a minute. The TR115 checks them all from power transistors to the small hearing aid type. Japanese equivalents are listed also. This famous tester is used by such companies as Sears Roebuck, Bell Telephone and Commonwealth Edison. New circuits enable you to make service checks without set-up charts even though charts are provided for critical checks.



Model TR115
Dealer Net
\$19.95



SENCORE BATTERY ELIMINATOR AND TROUBLE SHOOTER

For replacing batteries during repair. Many servicemen say that they wouldn't service transistor circuits without this power supply. The tried and proven PS103 is a sure fire answer. It can be used to charge the nickel cadmium batteries as well. Dial the desired output from 0 to 24 volts DC and read on meter. Low ripple insures no hum or feedback. Total current drawn can also be read on the PS103 by merely flicking the function switch to milliamps. The PS103 is the only supply that will operate radios with tapped battery supplies such as Philco, Sylvania and Motorola. No other supply has a third lead.



Model PS103
Dealer Net
\$19.95

Now in stock at your Authorized Sencore Distributor



SENCORE

ADDISON, ILLINOIS

by JOE A. GROVES

SERVICE VEHICLES

BUY OR LEASE?

About this time every year, many service dealers begin to think about getting a new truck or station wagon. With new models in dealers' showrooms and winter coming on again, it's easy to build up enthusiasm over this idea. If you're in a shopping mood, now is the time to give serious consideration to a question which may never have occurred to you before: "Should I buy or lease that new truck?"

Unfortunately, many owners of one- and two-man shops have never given a thought to the possibility of obtaining a service vehicle on a lease. They've simply considered leasing as being practical only for a big shop with a fleet of trucks. This conclusion has generally been based on assumptions rather than facts. Actually, leasing offers advantages to some companies (both large and small), while it doesn't to others.

Basic Questions

A service vehicle is a tool. As such, you're interested only in the

work it can do. Whether you should purchase the vehicle or lease it depends on your answers to several questions. For one thing, how long do you want to use the vehicle? Many dealers prefer to use a truck only a year or two before trading it for a new one. This helps build an "image" of a successful business. Others choose to get all the miles they can from a vehicle before laying out cash for a new one. If you favor the latter point of view, you can depreciate your truck to junk value in a period of four or five years, and leasing can't possibly compete. On the other hand, if you believe in using only newer vehicles, you should investigate various leasing plans.

Another factor that should be taken into account is wear and tear. If the truck is driven over 15,000 miles per year, or if it's subjected to hard use, leasing may offer the best deal. However, if the vehicle is driven a nominal number of miles per year and is well cared for, leas-

ing costs may be prohibitive, since depreciation charges are based on national averages.

Also to be considered is the trade-in market for various vehicles in the area where you live. Many service dealers prefer panel trucks or vans. Both styles traditionally have a lower trade-in value than pick-up trucks and station wagons, and in some areas where there is little demand for them, it's virtually impossible to trade them in without "taking a beating" on the deal. On the other hand, large leasing companies such as those listed here are able to take advantage of national marketing. This enables them to sell the vehicle in an area offering the top dollar at the expiration of the lease, and thereby reduce your total cost of depreciation. Incidentally, even smaller towns have new-car dealers and leasing firms who are affiliated with national organizations. To find out who offers leasing in your area, look under "Trucks-Motor-Rental" in the *Yel-*



Corvair 95



Standard

Ford "Econoline" vans and pickups give choice of two six-cylinder engines and have three-speed manual shift. "F-100" series offers six types of transmissions and either six- or eight-cylinder engines.

Chevrolet offers four six-cylinder and two V8 engines, optional AC generators with output up to 62 amps at relatively low engine speeds, turn signals, and an added automatic choke on "Corvair 95" series.



Econoline



F-100



Metro-Mite



C-100

Volkswagen panel has 170 cu. ft. of cargo space. The pickup has 23 cu. ft. of storage space and fold-down side panels. Both are equipped with a four-cylinder, air-cooled engine and four-speed manual transmission.

International "Metro-Mite" series offers 200 cu. ft. body with a four-cylinder engine, and 250 cu. ft., six-cylinder version. The C-100 pickup has a 7' body and option of three six and one eight-cylinder engines.



Panel



Pickup

Can you afford to guess

AT SWEEP, SYNC OR HIGH VOLTAGE TROUBLES?

WHEN IT'S SO EASY TO WALK THE TROUBLE RIGHT OUT OF CIRCUITS THESE TIME CONSUMING STEP BY STEP.....



SYNC. CIR. & H. SYNC. DISCRIM.	VERT. OSC.	VERT. OUTPUT	VERT. OUTPUT XFORMER	VERT. DEFLEC. YOKE
HORIZ. OSC.	HORIZ. OUTPUT	HORIZ. FLYBACK XFORMER	2nd ANODE VOLTAGE CIRCUIT	HORIZ. DEFLEC. YOKE



NEW, IMPROVED SENCORE SWEEP CIRCUIT ANALYZER MODEL SS117

How many times do you ask, "Why do I take so long finding that sweep trouble?" How often have you wondered whether weak horizontal sync was caused by defective sync circuit, horizontal oscillator, or sync discriminator? Can you quickly isolate adequate width or low 2nd anode voltage to the oscillator, output, flyback transformer, or yoke? How many times have you changed a good yoke by mistake?

The SS117 will pinpoint troubles like these in minutes with tried and proven signal injection, plus yoke substitution for dynamic in-circuit tests. Error proof push button testing enables you to make all tests from the top of the chassis without removal from cabinet for maximum speed and profit on every job.

Here are the checks the SS117 makes . . .

- Horizontal Oscillator: Checked by substituting 15,750 variable output universal oscillator from SS117. Signal can be injected at any spot from horizontal output grid to horizontal oscillator to determine defective component.
- Horizontal Output Stage: Checked by reliable cathode current and screen voltage checks made with adapter socket and two push buttons.
- Horizontal Output Transformer: Checked for power transfer in circuit and read as good or bad on meter.
- Horizontal Deflection Yoke: Checked by direct substitution with adjustable universal yoke on SS117.

- Vertical Oscillator: Checked by substituting 60 cycle synchronized oscillator.
- Vertical Output Transformer: By simple signal injection for full height on picture tube.
- Vertical Deflection Yoke: By signal substitution for full height on picture tube.
- Sync Stages: Checked by synchronizing triggered horizontal SS117 oscillator from any stage. If oscillator synchronizes, sync is O.K.
- 2nd Anode Voltage: A new dynamic check using simulated picture tube load. C.R.T. does not need to be operating for current tests. No interpretations—read direct from 0 to 30 KV.
- External Circuit Measurements: By applying from 0 to 1000 volts AC or DC to external meter jacks. Meter will read DC or peak-to-peak volts. 0 to 300 milliamp scale also provided for measuring horizontal fuse current.
- New features include: Large 0 to 300 microamp meter for minimum circuit loading; all-steel carrying case with full mirror in adjustable cover; two 115 volt AC outlets in cable compartment.

Size: 10 1/4" x 9 1/4" x 3 1/2". Wt. 10 lbs.

Model SS117

Dealer Net **\$89⁵⁰**

SEE YOUR AUTHORIZED SENCORE DISTRIBUTOR

SENCORE
ADDISON, ILLINOIS



Sencore Sam says . . . How can you miss . . .

EACH PACKAGED UNIT CONTAINS:

- An Easy to Follow Instruction Book Especially Prepared and Edited by H. W. Sams.
- A complete 33 RPM, 10 inch Permanent Record on "How to Simplify Sweep Circuit Trouble Shooting."

low Pages of your phone book.

It is important that you consider whether or not your need for a specific vehicle will last for the duration of a lease. Various types of contracts are available for terms ranging from one to three years. If there is any question of needing the vehicle for a specified period, you should either buy it or have a lease drawn with provisions to buy the vehicle if you desire. Either of these alternatives will permit you to dispose of the vehicle if you no longer need it; this relieves you of your obligation to pay a monthly rental fee for unnecessary equipment.

What is Buying?

Everyone is aware of what's involved in buying a truck. You make a down payment (perhaps handled entirely by the trade-in) and finance the balance over a period of up to 36 months at a fixed interest rate. At the end of the three years, you own the truck, which is worth approximately one-fourth its original price. When you compare your total payments (including interest) with the trade-in value at the end of three years, you may be amazed to discover the small amount of net worth you've gained from your in-

vestment. However, as was pointed out, you've had the use of the vehicle—and of course you own it, whatever it is worth.

What is Leasing?

There are two basic types of leases. The most popular is known as the *Finance Lease*. The company simply provides a vehicle for your use; you take care of all maintenance and regular operating costs such as insurance, gas, oil, and tires. The other type, the *Maintenance Lease*, is available with several options that include the cost of upkeep, insurance, oil changes and lubrication, total depreciation, etc. However, under any option, you still pay for the gasoline and any oil that must be added between changes. Recent studies have shown that it is impractical to have a *Maintenance Lease* for a vehicle driven less than 17,000 miles per year when the contract is for a two-year period or less.

Finance leasing provides you with the vehicle of your choice for X dollars per month for a period of one to three years. At the end of the contract, you have no equity, but you also have made no initial investment. A typical rental fee for a vehicle which retails for \$2000 will run from \$55 to \$65 per month during the first year or 18 months, but will progressively decrease if the contract extends longer.

The monthly fee is based on three things: A percentage of the purchase price, a return on the leasing company's investment, and depreciation. The latter, which constitutes the biggest part of the monthly rental fee, is held in an escrow account by the leasing firm. At the end of the contract, the vehicle is sold by the leasing firm. The sale price and depreciation reserve are then added together and subtracted from the original price, and the balance in reserve is returned to you. If the truck has suffered from high mileage or misuse which results in a lower selling price and a deficiency in the depreciation allowance, you make up the difference; however, this seldom happens.

Because of the wide variety of leases available, it is wise to contact various leasing companies to determine the plan best suited to your individual needs.

Coming to a Decision

As a businessman, your first and

JUST IN TIME FOR A
HOLIDAY BONUS!

FREE

*genuine cultured pearl
in heart pendant*

NECKLACE

with gold-filled chain

\$3.95

RETAIL VALUE



with every **Perma-Power** VU-BRITE 12-PACK



Perma-Power Vu-Brite 12-Pack gives you

USUAL PRICE

\$10.68

12-C401 Parallel or C402 Series
Vu-Brites

DEALER NET

\$3.95

1-FREE Cultured Pearl
Necklace

\$14.63

TOTAL VALUE

\$9.95

SPECIAL OFFER

\$4.68

TOTAL SAVINGS

HURRY! DEAL ENDS DECEMBER 15, 1961

Perma-Power COMPANY • 3102 N. ELSTON AVE. • CHICAGO 18, ILL.

WORTH SHOUTING ABOUT!

NEW IMPROVED
MIGHTY MITE

NEW IMPROVED
MIGHTY MITE

NEW IMPROVED
MIGHTY MITE

NEW IMPROVED
MIGHTY MITE

Reaching New Peaks in
Performance, Portability and Price

MIGHTY MITE II

They're shouting from the hill tops. Technicians, engineers and test labs all say that the original Mighty Mite finds the tubes that large expensive testers miss. And now . . . here is the new improved Mighty Mite! Designed for the present and far into the future. Tests all of your present tubes plus the new RCA Nuvisitors and Novars, GE Compactrons and Sylvania 10 pin tubes.

A complete tube tester that is smaller than a portable typewriter yet outperforms testers costing hundreds of dollars. A real money maker for the serviceman and a trusty companion for engineers, maintenance men and experimenters.

Even though the Mighty Mite weighs less than 8 pounds, new circuitry by Sencore enables you to use a meter to check grid leakage as high as 100 megohms and gas conditions that cause as little as one half microamp of grid current to flow. Then too, it checks for emission at operating levels and shorts or leakage up to 120,000 ohms between all elements. This analytical "stethoscope" approach finds troublesome tubes even when large mutual conductance testers fail. And it does all this by merely setting four controls labeled A, B, C, & D.

Check these plus Sencore features: Meter glows in dark for easy reading behind TV set • Stainless steel mirror in ad-



67⁵⁰
DEALER NET

Remember . . . there is
only one Mighty Mite

justable cover for TV adjustments • Rugged, all steel carrying case and easy grip handle • Smallest complete tester made, less than one foot square. Mighty Mite II will test every standard radio and TV tube that you encounter, nearly 2000 in all, including foreign, five star, auto radio tubes (without damage) plus the new GE Compactrons, RCA Nuvisitors and Novars and Sylvania 10 pin tubes.

Mighty Mite II also has larger, easy-to-read type in the set-up booklet to insure faster testing. Why don't you join the thousands of servicemen, engineers, and technicians who now own a Mighty Mite tube tester? Tube substitution is becoming impossible and costly with nearly 2000 tubes in use today. Ask your authorized Sencore Distributor for the New Improved Mighty Mite. Size: 10¼" x 9¼" x 3½". Wt. 8 lbs.

MODEL TC114

Sencore Sam says . . . "They all agree . . .
the Mighty Mite is the real answer for the man on the go."



SENCORE ADDISON, ILLINOIS

foremost concern is to see that your money is invested wisely. Therefore, you need to consider more than the total cost of a truck under both the lease and buy options. Naturally, total cost plays its part—and in some cases, it is the deciding factor. However, it's possible for a slightly higher total cost of a lease to be more than offset by increased revenue from a different investment of capital.

For example, let's assume you have computed the depreciation, gas and oil expense, insurance, repairs, and service charges on your present vehicle for last year's operation. Also, you have divided the sum of these figures by the number of miles driven to find the cost per mile. Assume that the resulting figure is 8.81¢ per mile, and that a leasing quotation based on the same number of miles shows a cost

of 9.33¢ per mile. At first glance, buying appears more economical; if the computations were based on 10,000 miles, for example, you would save \$52 per year by owning the vehicle. On the other hand, if we consider that the vehicle costs \$2000, at least \$650 must be invested in a down payment. Ask yourself another question: "Can I make or save more than \$52 (the additional cost of leasing) by investing \$650 in something other than a truck—say, in merchandise or equipment?" If the answer is a resounding "Yes," the lease, although more expensive, may afford the best solution. However, if you can spare the capital, you'll probably be better off buying the truck.

In making your final decision, determine what you have previously spent to operate your truck. Next, check with the various dealers in

your area to see what kind of a deal you can make. Then compare the best figure with the arrangements offered by various leasing firms. With all these facts at hand, you should have little trouble deciding what's best for you.

National Leasing Companies

Avis Rent-A-Car System

17 Irvington St., Boston, Mass.

Ford Authorized Leasing System

250 Ford Dealers Across Country

Hertz Truck Leasing

501 10th Ave., New York, N.Y.

Service Leasing Corp.

650 Madison Ave., New York, N.Y.

Wheels, Inc.

6200 N. Western Ave., Chicago, Ill.

For local leasing firms, consult the Yellow Pages of your phone book. ▲

NEW TRANSISTOR TV-FM WINEGARD TENNA- BOOST

MOUNTS ON ANY ANTENNA

NEXT BEST THING TO THE
WINEGARD ELECTRONIC
POWERTRON TV ANTENNA

MOUNTS ON
ANTENNA

ON MAST

ON WALL

Model
MA-300

\$34⁹⁵
only LIST

INSTALL IT . . . FORGET IT!

ALL ELECTRIC, ALL-AC POWER SUPPLY costs less than 27c a year to operate. Many exclusive features.

No costly, nuisance batteries!



Built-in two set coupler.



Exclusive Gain Control Switch



AC outlet on power supply.

19 DB GAIN! CUTS SNOW...BOOSTS SIGNAL!

Now you can make any TV or FM antenna work better by magnifying signals with the new Winegard transistor Tenna-Boost.

Tenna-Boost has up to 19 DB gain, no peaks and valleys. Ultra low noise. Linear frequency response. VSWR input better than 1.5:1 across all frequencies. Output VSWR 1.8:1 or better. This fine frequency response plus the very low VSWR make Tenna-Boost excellent for color.

Winegard's *exclusive* input band-pass filter eliminates interference from citizen's band, Hams, garage door openers, etc. Only TV and FM signals are amplified.

All metal parts are anodized, irridized or stainless steel. Completely weather-proof, trouble-free. Install it . . . forget it.

There's a big difference in antenna amplifiers! Ask your distributor or write for technical bulletin.

FOR THE ULTIMATE IN TV RECEPTION

Winegard Transistorized Electronic Powertron TV Antennas. 3 Models to Choose From.



Winegard®

ANTENNA SYSTEMS

3009-10 Kirkwood • Burlington, Iowa

Fuseholders

for BUSS
and FUSETRON
FUSES



ALL TYPES
TO SUIT
YOUR NEEDS

**BUSS
and FUSETRON
FUSES: One source
for all your
fuse needs.**



Get full data for your files, write for BUSS
bulletin, Form SFB—it gives a comprehensive picture
of the complete line of fuses and fuse mountings of
unquestioned high quality.

BUSSMANN MFG. DIVISION, McGraw-Edison Co., UNIVERSITY AT JEFFERSON, ST. LOUIS 7, MO.

SERVICING
INDUSTRIAL ELECTRONICS
by ED BUKSTEIN

Electronic Control of Lighting

Driving home from work one of these fall evenings, perhaps you'll notice the street lights wink on. Later, you may attend a show, and watch the house lights dim as the program begins. There's a good chance that both these actions are being controlled by electronic circuits similar to those used in countless other industrial and commercial applications.

Photoelectric Relay

Illumination controls maintain adequate lighting in many factories, offices, and other work areas. Photoelectric relays turn on the room lights when the natural (daylight) illumination falls below a certain level, either at sunset or during overcast weather, and turn them off automatically when no longer needed. Illumination controls are also useful for turning on emergency lights in hospitals, street lights, tower lights of broadcast stations, field lights at unattended airfields, etc.

Fig. 1 is a schematic of a typical illumination control. Grid current in the control tube charges C1 during the half-cycles of supply voltage when the grid end of the power-transformer secondary is more positive than the opposite end. The path and polarity of the charge are indicated in Fig. 2A. Note that the lower end of the transformer is returned to the cathode circuit of the

control tube through potentiometer R1, which determines the charge accumulated by the capacitor.

During the opposite half-cycles of supply voltage, the capacitor partially discharges through the phototube, as shown in Fig. 2B. If daylight illumination is weak or absent, the phototube conducts only slightly, and only a small portion of the charge leaks off the capacitor. Since most of the charge is retained, the grid is held negative, and the plate current of the control tube is insufficient to energize relay M1. Under these conditions, the contacts of M1 short out R3, allowing sufficient current flow to energize M2. This heavy-duty contactor keeps the artificial lights turned on.

When natural light is bright enough that no artificial illumination is required, the phototube conducts heavily enough to dissipate much of the charge on C1. The negative potential on the control-tube grid is thus reduced, and M1 is energized. This removes the short circuit from across R3 and transfers it to the coil of M2, which becomes de-energized and turns off the lights.

The removal of artificial lighting causes a sudden drop in the total illumination striking the phototube. The light level might fall below the threshold required to keep M1 energized, and the lights might be turned on again, if the control system did not include stabilizing circuitry. To prevent repeated on-off cycling, an additional set of contacts on M1 grounds the tap of

Editor's Note: This article has been adapted from the new Howard W. Sams book, "Industrial Electronics Measurement and Control," by Edward Bukstein.

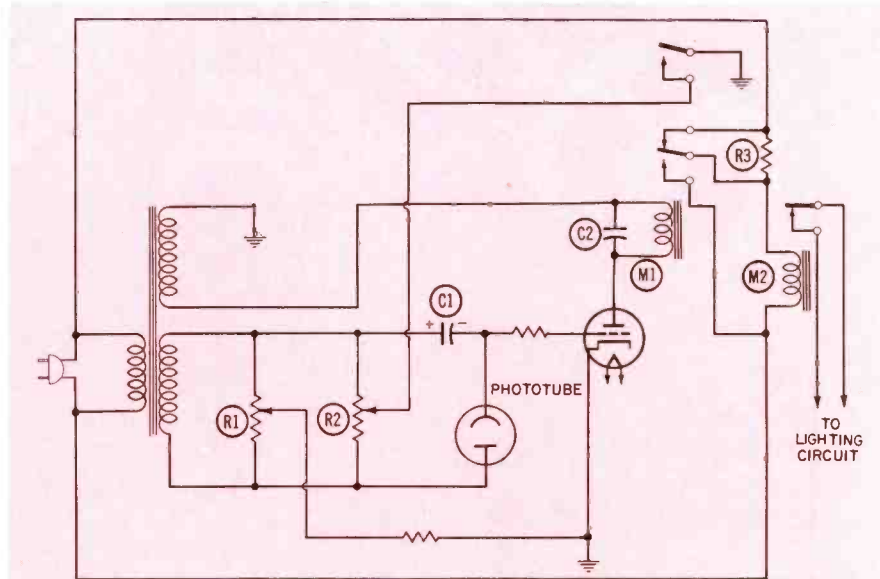

Fig. 1. Photoelectric "light switch." Assume dim light falling on phototube.

RCA *MERCURY* RADIO BATTERIES

GUARANTEED
AGAINST DAMAGE FROM LEAKAGE



The Radio Corporation of America guarantees to repair your radio or replace it with one of comparable value (at RCA's option) and supply the appropriate battery complement without charge, if ever damaged by leakage of an RCA mercury radio battery. If RCA mercury radio batteries should ever leak and damage your radio set, send radio with batteries, transportation collect to:

RCA BATTERY DEPARTMENT
415 South Fifth Street, Harrison, New Jersey



The Most Trusted Name in Electronics

Step up to Bigger Profits

with RCA Mercury Batteries
now **GUARANTEED** against
damage from leakage in any radio

This RCA guarantee on Mercury Batteries makes it easier than ever to sell this high-profit line of batteries.

With their long life, fade-free performance and outstanding reliability, Mercury Batteries are the smartest, most economical battery buy your customers can make. Get the most out of the booming transistor radio market by displaying and promoting **GUARANTEED** RCA Mercury Batteries.

Contact your Authorized RCA Distributor for new sales-building promotional material featuring this RCA guarantee.



The Most Trusted Name in Electronics



More good news! The popular, fast-selling VS 323 and VS 300A zinc-carbon types now carry this same guarantee!

how often
could you
have used...

an
Xcelite
"Seizer"?

Handy as an extra
hand or helper.
Clamps lightly
or tightly ... for
moments or minutes.

two-position
snap-lock

slim, serrated jaws

Outreaches, out-holds needle-nose pliers. Hardly a spot too small for it. Approx. 6" long. Dozens of uses: Holds and positions wires for soldering... retrieves small parts from inaccessible places... it's a heat sink. Two-position snap-lock won't slip, yet releases with a twist of the fingers. All stainless steel—precision mackined and tempered for smooth action and years of service.

2 Models: No. 43H curved nose and No. 42H straight—Ask your distributor to show you Xcelite Seizers today.

XCELITE

XCELITE, INC. • ORCHARD PARK, N. Y.
Canada: Charles W. Pointon, Ltd., Toronto, Ont.

potentiometer R2. The tap is normally positioned near the grid end of R2 to limit the charge that can be accumulated by C1, and thus to reduce the grid bias. M1 then remains energized until the daylight illumination of the phototube becomes insufficient to keep C1 discharged.

C2, connected across the coil of M1, charges during positive alternations of the AC plate-supply voltage (assuming adequate daylight illumination). This charge keeps M1 energized during negative alternations of voltage, when the tube cannot conduct.

Light-Dimming Control

In auditoriums, theaters, etc., a means of varying the brightness of the lights is required. Although they can be dimmed by connecting rheostats in series with the lights, the rheostats would have to be high-wattage types that generate a large amount of heat. A more satisfactory method is to connect the load winding of a saturable reactor in series with the lights. The basic circuit is shown in Fig. 3. A portion of the supply voltage is dropped across the reactor, and the remaining voltage appears across the lights. Since the amount of voltage across the reactor can be varied, the voltage across the lights (and hence their brightness) can likewise be controlled.

The amount of voltage across the saturable reactor in Fig. 3 is determined by the inductive reactance of the load winding. This reactance, in turn, depends on the amount of DC current passing through the control winding.

A practical light-dimming circuit is shown in Fig. 4. As in Fig. 3, the load winding of the saturable reactor is connected in series with the lights to be controlled. The supply voltage will therefore divide; a portion will appear across the saturable reactor, and the remainder will appear across the lights. Since some of the supply voltage will be dropped across the reactor even when its core is completely saturated, the line voltage will receive *full* line voltage at maximum saturation.

A thyatron rectifies and controls the current through the control winding of the saturable reactor. In turn, the bias voltages across re-

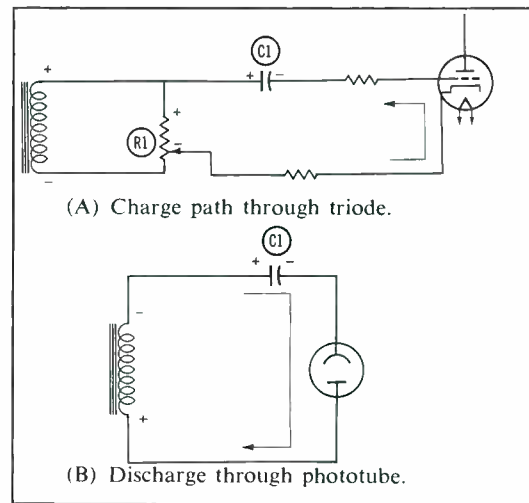

Fig. 2. Action of C1 in Fig. 1.

sistors R2 and R4 control the thyatron. The voltage across R2 attempts to drive the grid positive, and the voltage across R4 attempts to keep it negative. The actual bias is therefore equal to the *difference* voltage across R2 and R4 in series.

Potentiometer R1 is used to dim or brighten the lights. When the tap of R1 is moved below the setting shown in Fig. 4, the following changes occur in the circuit:

1. Less input voltage is available to rectifier V1, and less rectified voltage therefore appears across its load resistor R2.
2. The lower voltage across R2 constitutes an increase in thyatron bias. Because of this higher bias, the plate voltage of the thyatron must rise before ionization can occur.
3. Since the thyatron now fires *later* during each positive alternation of plate-supply voltage, a lower average current flows through the control winding of the saturable reactor.
4. The reactor core is now less saturated than before the setting of R1 was changed;

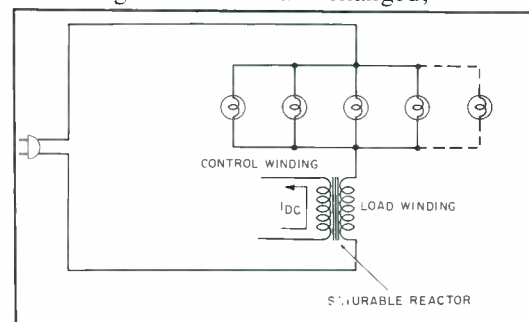

Fig. 3. Saturable reactor in series with lights controls their brightness.

New TRANSISTOR RADIO ANALYST

makes it Easy and Profitable to Service all Transistor Radios



B&K Model 960

TRANSISTOR RADIO ANALYST

with Exclusive *DYNA-TRACE*
Single-Point Probe—and Built-in
Metered Power Supply and VTVM

**Complete Transistor Radio
Service Shop in One Instrument**

Signal-Generator, Power Supply,
Milliammeter, VTVM, Battery Tester,
Ohmmeter, and Both In-Circuit and
Out-of-Circuit Transistor Tester—
All in One

Check all circuits - Pinpoint any trouble ... in minutes

Now you can profit from transistor radio servicing! This amazing new B&K "960" ANALYST gives you *everything* in one complete easy-to-use instrument. Makes transistor radio servicing *quick and easy*. Nothing else is needed except the transistor radios themselves waiting to be serviced. Brings you new customers for service, parts, and batteries. Makes this new business *yours*.

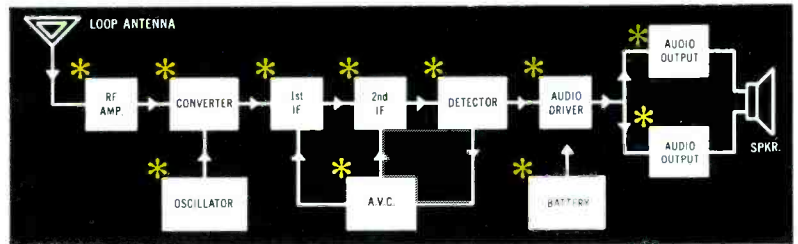

EASILY TROUBLE-SHOOT ANY STAGE BY UNIQUE POINT-TO-POINT SIGNAL INJECTION

The ANALYST gives you a complete signal-generating source for point-to-point signal injection. Easily enables you to trouble-shoot any transistor radio—check all circuits stage-by-stage—isolate and pinpoint the exact trouble in minutes.

Supplies modulated signals, with adjustable control, to check r.f., i.f., converter, and detector. Supplies audio signal to check audio driver and audio output. Provides unmodulated signal to test local oscillator. Provides separate audio low-impedance output for signal injection into loudspeaker voice coils to check speaker performance.

BUILT-IN METERED POWER SUPPLY FOR EASY SERVICING

Makes it easy to operate radio under test, while you inject your own signals. Provides from 1 to 12 volts in 1½ volt steps. Supplies all bias taps that may be required.

SIMPLIFIES IN-CIRCUIT TRANSISTOR TEST WITH NEW DYNA-TRACE SINGLE-POINT PROBE

Unique single-point probe needs only the one contact to transistor under test. No longer are three wires required to connect to emitter, base, and collector. Gives fast, positive meter indication. Saves time. Makes trouble-shooting simple and easy.

BUILT-IN VTVM

Includes high-input-impedance vacuum-tube voltmeter, which is so necessary for transistor radio servicing.

TESTS ALL TRANSISTORS OUT-OF-CIRCUIT

Meter has "Good-Bad" scale for *both* leakage and beta. Also has direct-reading Beta scale, calibrated 0-150. Assures quick, accurate test. Also automatically determines whether transistor is NPN or PNP. Meter is protected against accidental overload and burn-out.

Model 960. Net, \$99⁹⁵

Solve Every Service Problem and Profit
with a Modern B&K Service Shop. See Your
B&K Distributor or Write for Catalog AP18-R



B & K MANUFACTURING CO.
1801 W. BELLE PLAINE AVE • CHICAGO 13, ILL.
Canada: Atlas Radio Corp., 50 Wingold, Toronto 19, Ont.
Export: Empire Exporters, 277 Broadway, New York 7, U.S.A.

Miniature I. F. TRANSFORMERS OSCILLATOR COILS and LOOP ANTENNAS for Transistor Sets

GENERAL REPLACEMENTS FOR
IMPORTED and DOMESTIC SETS

Size $\frac{3}{8}$ " x $\frac{3}{8}$ "
PART NO. OPERATION
455-A1 INPUT
455-A2 INTERSTAGE
455-A3 OUTPUT
455-OA OSCILLATOR

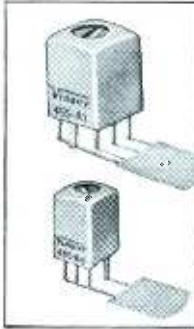

Size $\frac{1}{4}$ " x $\frac{1}{4}$ "
PART NO. OPERATION
455-B1 INPUT
455-B2 INTERSTAGE
455-B3 OUTPUT
455-OB OSCILLATOR

Packaged in Plastic See-
Thru box in display carton
with instruction

MODEL LA-14
FOR USE WITH
148 MMFD.
TUNING
CONDENSER

SIZE
 $1\frac{1}{8}$ " x $\frac{1}{8}$ "



MODEL LA-21
FOR USE WITH 211 MMFD.
TUNING CONDENSER —

SIZE 2-5/16 x 11/16

MODEL LA-36
FOR USE WITH 365 MMFD.
TUNING CONDENSER —

SIZE 2-13/16 x 11/16

Packaged in plastic bag on display card

Vidair ELECTRONICS MFG. CORP.
365 BABYLON TPKE. — ROOSEVELT, N. Y.

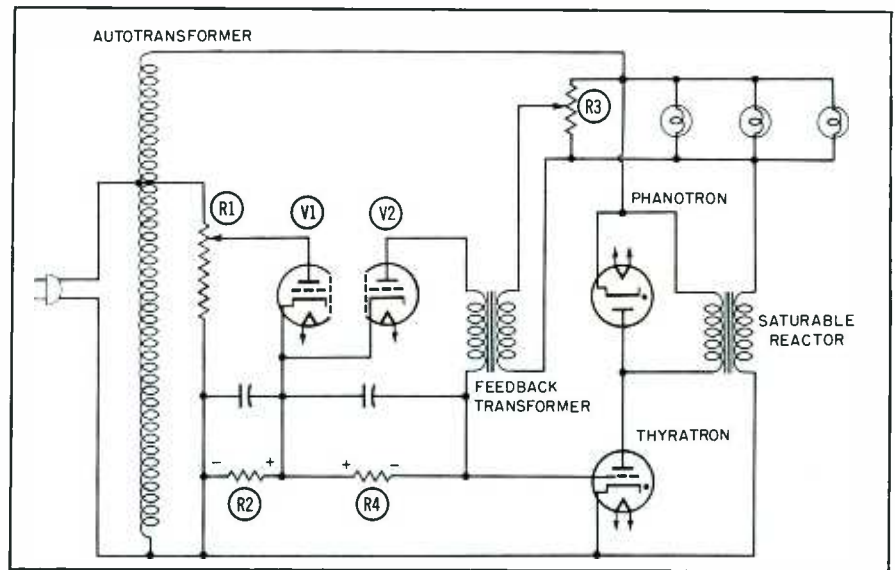

Fig. 4. Practical dimming circuit includes features to increase stability.

therefore, the inductive reactance of the load winding is greater.

5. More supply voltage is dropped across R2. In addition, the feedback circuit keeps the brightness constant if more lamps are added in parallel or if some are cut out of the circuit. Inserting more lamps would ordinarily result in dimmer light from each lamp, because the increased current would produce a greater voltage drop across the reactor. However, the feedback circuit compensates for the decrease of lamp voltage by reducing the drop across R4. Since the thyatron then operates at a lower bias, it fires at a lower plate voltage (earlier during the positive alternation of plate supply). Higher average current then flows through the control winding of the reactor, and the core becomes more saturated. As a result, the reactance of the load winding is decreased, and so is the voltage across this winding. Because less supply voltage is dropped across the reactor, the individual lamps do not dim even though more have been added in parallel. The feedback circuit produces the opposite action when lamps are removed from the circuit.

Moving the tap of R1 upward will produce opposite changes and brighten the lights.

Because the thyatron can conduct only during positive alternations of plate-supply voltage, a phanotron (gas-filled diode) is connected across the control winding of the saturable reactor to provide the following action: When the thyatron conducts (positive alternation of plate supply), current flows through the reactor and establishes a magnetic field. When the thyatron stops conducting (negative alternation of plate supply), this magnetic field begins to collapse. As it cuts across the control winding, a counter emf is induced in the winding. This counter emf is negative at the cathode of the phanotron and positive at the plate. As a result, the phanotron ionizes and provides a path for current to flow, with the counter emf acting as a voltage source. In this manner, current flow is maintained through the control winding during the half-cycles when the thyatron cannot conduct.

A feedback transformer connected to potentiometer R3 samples the voltage across the lights. The secondary voltage of this transformer, rectified by diode V2, appears across R4. This feedback

helps to stabilize the circuit against line-voltage variations by counteracting the voltage change they cause across R2. In addition, the feedback circuit keeps the brightness constant if more lamps are added in parallel or if some are cut out of the circuit. Inserting more lamps would ordinarily result in dimmer light from each lamp, because the increased current would produce a greater voltage drop across the reactor. However, the feedback circuit compensates for the decrease of lamp voltage by reducing the drop across R4. Since the thyatron then operates at a lower bias, it fires at a lower plate voltage (earlier during the positive alternation of plate supply). Higher average current then flows through the control winding of the reactor, and the core becomes more saturated. As a result, the reactance of the load winding is decreased, and so is the voltage across this winding. Because less supply voltage is dropped across the reactor, the individual lamps do not dim even though more have been added in parallel. The feedback circuit produces the opposite action when lamps are removed from the circuit.

Conclusion

The two circuits just described are typical examples of the systems most commonly used for illumination control. An understanding of their operation, coupled with a logical approach to troubleshooting, will provide the basic background needed for servicing devices of this type. ▲

NOW! . . . IT'S
QUIETROLE
with the
FREE EXTENDER TUBE



Quality QUIETROLE, your first choice "Lubri-Cleaner" in silencing noisy controls and switches on TV, radio and electronic instruments now provides you with a FREE EXTENDER TUBE to easily reach those once "hard-to-get-at" places. You'll like QUIETROLE better than ever now . . . In spray can or bottle.

IN SPRAY CAN or
2, 4, 8 oz. BOTTLES

manufactured by

QUIETROLE
COMPANY

Spartanburg, South Carolina

In Canada: CROSS CANADA ELECTRONICS
12 Laurel Street, Waterloo, Ontario



First real VOM advance in 20 years

SET IT!

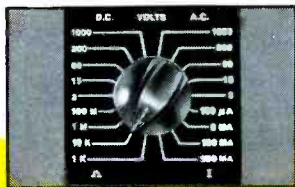

SEE IT!



READ IT!

DIRECTLY—ACCURATELY
WITHOUT MULTIPLYING



ALL-NEW

B&K

V O Matic 360

AUTOMATIC VOLT-OHM-MILLIAMMETER

- Individual Full-Size Scale for Each Range
- Range Switch Automatically Sets Correct Scale
- Only One Scale Visible at Any Time
- No Multiplying . . . No False Readings
- Meter Protected Against Extreme Overload
- Mirrored-Scale for Precise Readings



WITH
BURN-OUT PROOF
METER

EASIEST—FASTEST—ERROR-FREE READINGS

Once you set the range switch properly, it is impossible to read the wrong scale. Readings are easiest, fastest of all—so easy the meter “practically reads itself.” Eliminates reading difficulties, errors, and calculations.

All scales, including the ohms scale, are direct reading. You do not have to multiply. Saves time and trouble. Gives you the right answer immediately. Ohms-adjust control includes switch that automatically shorts out test leads for “zero” set.

Every scale in the V O Matic 360 is the same full size . . . and only one scale is visible at any one time, automatically. Supplemental ranges are also provided on separate external overlay meter scales.

This new-type automatic VOM is another innovation by B&K that gives you features you’ve always wanted. Outdates all others.

Net, \$59⁹⁵

Includes convenient stand to hold “360” for correct viewing in 4 positions.

- Ranges:** DC Volts — 0 - 3, 15, 60, 300, 1000, 6000 (20,000 Ω/v)
 AC Volts — 0 - 3, 15, 60, 300, 1000, 6000 (5,000 Ω/v)
 AF (Output)— 0 - 3, 15, 60, 300 volts
 DC Current — 0 - 100 μa, 5 ma, 100 ma, 500 ma, 10 amps
 Resistance — 0 - 1000 ohms (3 Ω center)
 0 - 10,000 ohms (50 Ω center)
 0 - 1 megohm (4 k Ω center)
 0 - 100 megohms (150 k Ω center)

- Supplemental Ranges:** 18 separate external overlay meter scales for:
 DC Volts— 0 - 250 mv Capacitance—100 mmfd to 4 mfd
 Audio Power Output—up to 56 watts DB (decibels)
 Peak-to-Peak AC (sine) Volts— 0 - 170, 850

Polarity Reversing Switch and Automatic Ohms-Adjust Control

Frequency Response AC: 5 - 500,000 cps

Burn-Out Proof Meter: Protected against overload and burn-out

Complete with 1½-volt and 9-volt batteries and test leads

Ask Your B&K Distributor for Demonstration
or Write for Catalog AP 18-R



B & K MANUFACTURING CO.
 1801 W. BELLE PLAINE AVE • CHICAGO 13, ILL.
 Canada: Atlas Radio Corp., 30 Wingold, Toronto 19, Ont.
 Export: Empire Exporters, 277 Broadway, New York 7, U.S.A.

A GRANCO FIRST!



GO WITH
EXCLUSIVE
GRANCO FM
CAR RADIO
CONVERTER!

ONLY \$49.95

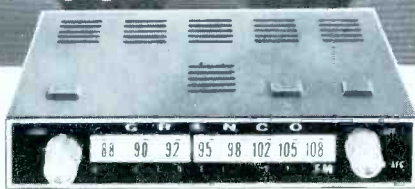

Add the beauty in sound of Granco FM to AM car radio in a marvel of minutes. Superb quality . . . compact design — only 1¼" thick . . . and ease of installation make this Granco innovation a "must" for every car.

Get in on this big new profit maker . . . write for details today!
GRANCO America's Leading Specialist in FM Dept. PF-10
DIVISION • DUMONT EMERSON CORP., 680 FIFTH AVE., N.Y.C.

NEW! SARGENT ELECTRONIC CHEMICALS and FINISHES

SARGENT TUNER CLEANER

Thoroughly cleans tuners and controls. Protects against future corrosion, oxidation and contact wear. Non-flammable.

Giant 16.4 Ounce Can **\$1.47** Dealer Net

Includes plastic extension tube.

SARGENT GEAR AND PARTS CLEANER

Instant cleaning power for turntables, tape recorders, business machines and electronic devices. Flushes away dirt, oil and grease in gears and parts. Non-flammable.

Giant 16.4 Ounce Can **\$1.19** Dealer Net

Includes plastic extension tube.

OTHER PRODUCTS IN THE SARGENT ELECTRONICS LINE

Red Insulator, Degreaser, Clear Acrylic Plastic, Penetrating Oil, Squeak Stopper, Enamels, Lacquers, Metallics, Engine Enamels, Stop Rust, and other Specialties.

For Free Literature and Prices, Check Your Electronics Parts Distributor, or write . . . **ELECTRONICS DIVISION**

THE SARGENT-GERKE CO.

Producer of Paints and Chemicals for Over 60 Years
P. O. Box 729 • INDIANAPOLIS 6, INDIANA



The Electronic Scanner

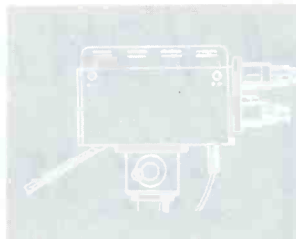

South River Expands

Tooling facilities of the recently-liquidated Penn Television Products Co. have been purchased by South River Metal Products Co., Inc. As a result, South River will now produce the line of mounting hardware formerly manufactured by Penn.

Battery Display Offered by Samco



A point-of-purchase display carton containing 116 batteries has been introduced by the Electronics Div. of The Sampson Co. This counter unit contains an assortment of the seven most popular battery types. Also included is a battery information and cross-reference guide, plus Samco battery-dealer window streamers.

New Type for Radio-Electronic Master



Effective with next year's 26th edition, the **Radio-Electronic Master**—one of the largest and best-known industry-wide component-replacement guides—will use complete new typesetting facilities just installed in the plant of its producer, **United Catalog Publishers, Inc.**

New Symbol and Slogan for Aerovox



Aerovox Corp. has modernized their trademark, which is to appear with the slogan, "Technical Leadership—Manufacturing Excellence," to "reflect the development of new products and advanced manufacturing techniques necessary to fulfill the more stringent demands of the rapidly-expanding electronics industry." Charles Golenpaul (seated) and Matthew Simon, Vice-President and Sales Manager of the Distributor Division, are shown examining the new design.

200,000 Mikes in Two Years



Just as a clue to how well things are going in the audio and commercial-sound segments of our industry, **Sonotone Corp.** has announced that over 200,000 "Ceramikes" have been sold in the past two years. In addition, **Sonotone** has sold over 10 million ceramic phono cartridges during the past 15 years.

JW Electronics Moves to Indiana

Mr. Wade Horn, owner-manager of the **JW Electronics** tuner-servicing company, has announced the completion of the firm's move from Chicago into newly-built larger quarters in Bloomington, Ind.

Impulse-Buying Display by Switchcraft



A 2' x 4' pegboard display unit for stereo/hi-fi accessories is now available through **Switchcraft** distributors. Designed to hold as many as 40 "skin-packaged" adapters, connectors, and interconnecting cords, the "M-40" merchandiser is available to the dealer with his choice of components, or as a separate item.

NEW

TESTS All TV and Radio Tubes
—both old and new

TESTS the Nuvistors

TESTS the new 10-pin tubes

TESTS the new 12-pin Compactrons

TESTS voltage regulators, thyratrons,
auto radio hybrid tubes,
European hi-fi tubes, and
most industrial types.



Model **600**
DYNA-QUIK

only **\$69⁹⁵**
NET

8½" x 11" x 4½"
Handsome, sturdy
leatherette-covered
carrying case

NEW TUBE
INFORMATION
SERVICE

available every 3
months for all B&K
Dyna-Quik Tube Testers



for the first time, a
B & K QUALITY
TUBE TESTER
at this
amazing low cost!

Checks for all shorts, grid
emission, leakage, and gas

Checks each section of multi-
section tubes separately

Checks tube capability under
simulated load conditions

Rejects bad tubes
—not good tubes

For the man who wants the performance and reliability of a B&K professional-quality tester at minimum cost . . . there's nothing like the new "600". No other tube tester in this price range is so complete and up-to-date. Tests the newest tube types, as well as the old. It's fast . . . it's accurate . . . it's easy to use. Quickly reveals tube condition. Saves customers. Sells more tube replacements. Stops call-backs. Steps up servicing profit . . . day after day. Pays for itself over and over again.

Exclusive adjustable grid emission test. Sensitivity to over 100 megohms. Phosphor bronze socket contacts. Complete tube listing in handy reference index. Extremely compact.

B & K MANUFACTURING CO.

1801 W. BELLE PLAINE AVE • CHICAGO 13, ILL.

Canada: Atlas Radio Corp., 50 Wingold, Toronto 19, Ont.

Export: Empire Exporters, 277 Broadway, New York 7, U.S.A.

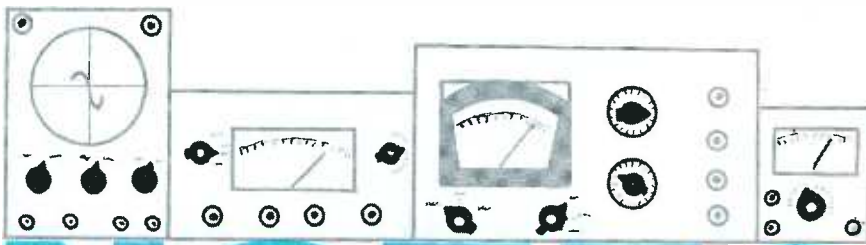

NOTES

ON TEST EQUIPMENT

by Les Deane

Combo Power Package



Fig. 1. Paco offers regulated, variable-voltage power supply in kit form.

The Model B-12 Regulated Power Supply (Fig. 1) is a new bench instrument manufactured by Paco (a division of Precision Apparatus and subsidiary of Pacotronics, Inc.) of Glendale, L. I., N. Y. This unit simultaneously supplies regulated B+, a bias potential, and AC heater power.

In addition to its uses as a handy servicing tool, the B-12 also serves as a versatile source of power for calibrating, designing, or experimenting with electronic circuits and systems. It comes either in kit form or prewired.

Specifications are:

1. *Power Requirements* — 105/130 volts, 50/60 cps; power consumption less than 50 watts with no load; line-isolated and fused; power switch and indicator provided on panel.
2. *Regulated Output* — variable DC from 0 to 400 volts; maximum continuous load 100 ma (intermittently 125 ma) up to 200 volts; maximum continuous load 150 ma from 200 to 400 volts; output variation less than .3% (or .3 volt) from 0 to 100 ma, and less than .4% (or .5 volt) with $\pm 10V$ line-voltage fluctuations; output impedance less than 10 ohms from DC to 1 mc; output voltage and current

monitored on panel meter.

3. *Bias Output* — continuously variable DC from 0 to 150 volts, also regulated; maximum load 2 ma; output voltage monitored on panel meter.
4. *AC Output* — two 6.3V (rms), 3-amp heater supplies; can be paralleled for 6.3V at 6 amps, or placed in series for 12.6V at 3 amps; one supply center-tapped; isolated terminals provided on panel.
5. *Panel Meters* — 2½" D'Arsonval movements; voltmeter scales 0 to 150 and 0 to 400 with range selector on panel; milliammeter scale 0 to 200 with smallest scale division 10 ma.
6. *Size and Weight*—8½" x 13" x 7¼", 17 lbs.

The meter in the upper right section of the front panel monitors output voltage, while the one on the left is a milliammeter. Of the 10 universal-style binding posts across the bottom of the panel, two are for bias, five are for AC heater power, and three (+, —, and chassis ground) are for the regulated B+ output.

Separate controls are provided for varying the two DC voltages, and in the center of the panel are three switches—a toggle line switch, a slide type for selecting voltmeter ranges, and another toggle which merely removes power from the REGULATED OUTPUT terminals.

Although the instrument is not capable of handling B+ loads imposed by most TV sets, I found it well suited for powering TV tuners and remote units, radios and radio chassis from combos, audio amplifiers, and other similar gear. The bias feature is also convenient for troubleshooting AVC and AGC faults, clamping points for alignment, and many circuit-design applications.

I was interested to see if the supply could be used for powering transistor portables. After trying this in the lab, I found it did an excellent job; regulation was still good at the low voltages involved, and the AC ripple content was not even detectable. However, since the smallest division on the meter scale for the main regulated supply was 10 volts, I found it more accurate to use an external voltmeter when monitoring such low levels of voltage.

This new Paco unit is more than just a simple AC to DC converter with added tube-filament supplies. Its unique circuit, which employs five vacuum tubes and two gas-filled voltage regulators, is shown in Fig. 2. Considering the regulated B+ output first, note that the power transformer feeds AC to full-wave rectifier V1. In the output circuit of this rectifier, a pair of 6L6GC's act as series regulators. These tubes, in turn, have a control tube (V4, a 6AU6). Notice, too, that the screen voltages of V2 and V3 plus the plate voltage for V4 are supplied by a separate rectifier circuit.

If the voltage across the output terminals attempts to change, an increase or decrease in potential is immediately produced across R18. This varies the control-grid voltage of V4, and conduction of this stage affects the bias on the

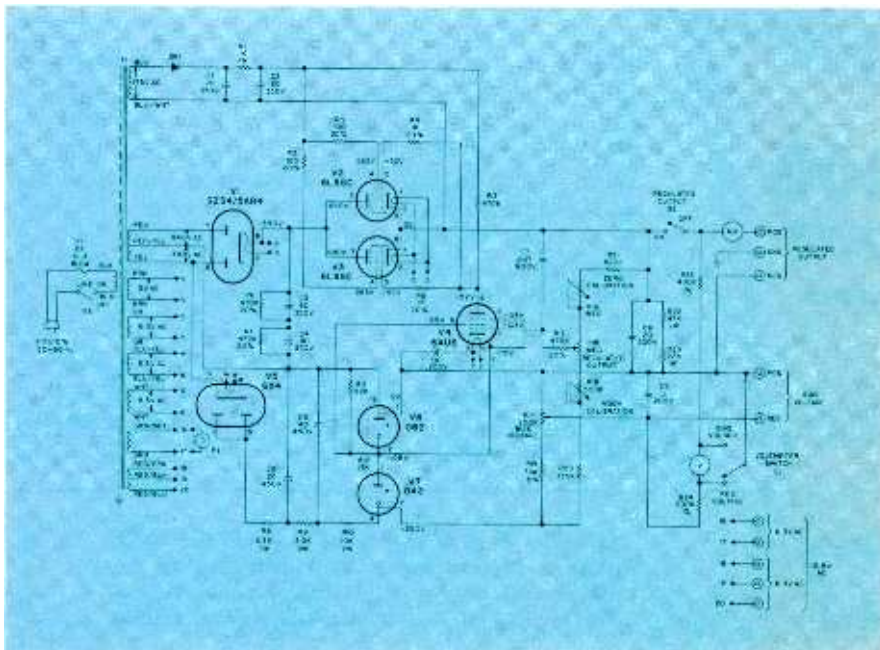

Fig. 2. Manufacturer's schematic of B-12. Note unusual regulation circuit.

NEW RCA VICTOR COLOR TV!

New Performance! New Serviceability!

New High-Fidelity Picture Tube! RCA VICTOR's all-new, all-sulphide color picture tube, coupled with the improved bandwidth of the amplifier section, reproduces incredibly lifelike color . . . a higher brightness level . . . more detailed picture content.

New Vista Tuner! This is the super-powerful RCA VICTOR tuner that has proved in performance it can pull in a sharper, clearer picture than any other . . . even in many difficult signal areas.

New Push-Button Circuit Breaker! Provides positive protection of the chassis components—resets simply by pressing and releasing a button—eliminates the special B-plus fuse previously required for protection of the deflection circuitry.

New High-Voltage Connector! Provides for easy measurement of voltage at the anode connector . . . simplifies connecting and disconnecting of high voltage. Saves you time . . . makes servicing more profitable.

Be sure to watch Walt Disney's new series, "The Wonderful World of Color" every Sunday, NBC-TV Network
TMK(S)®



The Most Trusted Name in Color Television

RADIO CORPORATION OF AMERICA

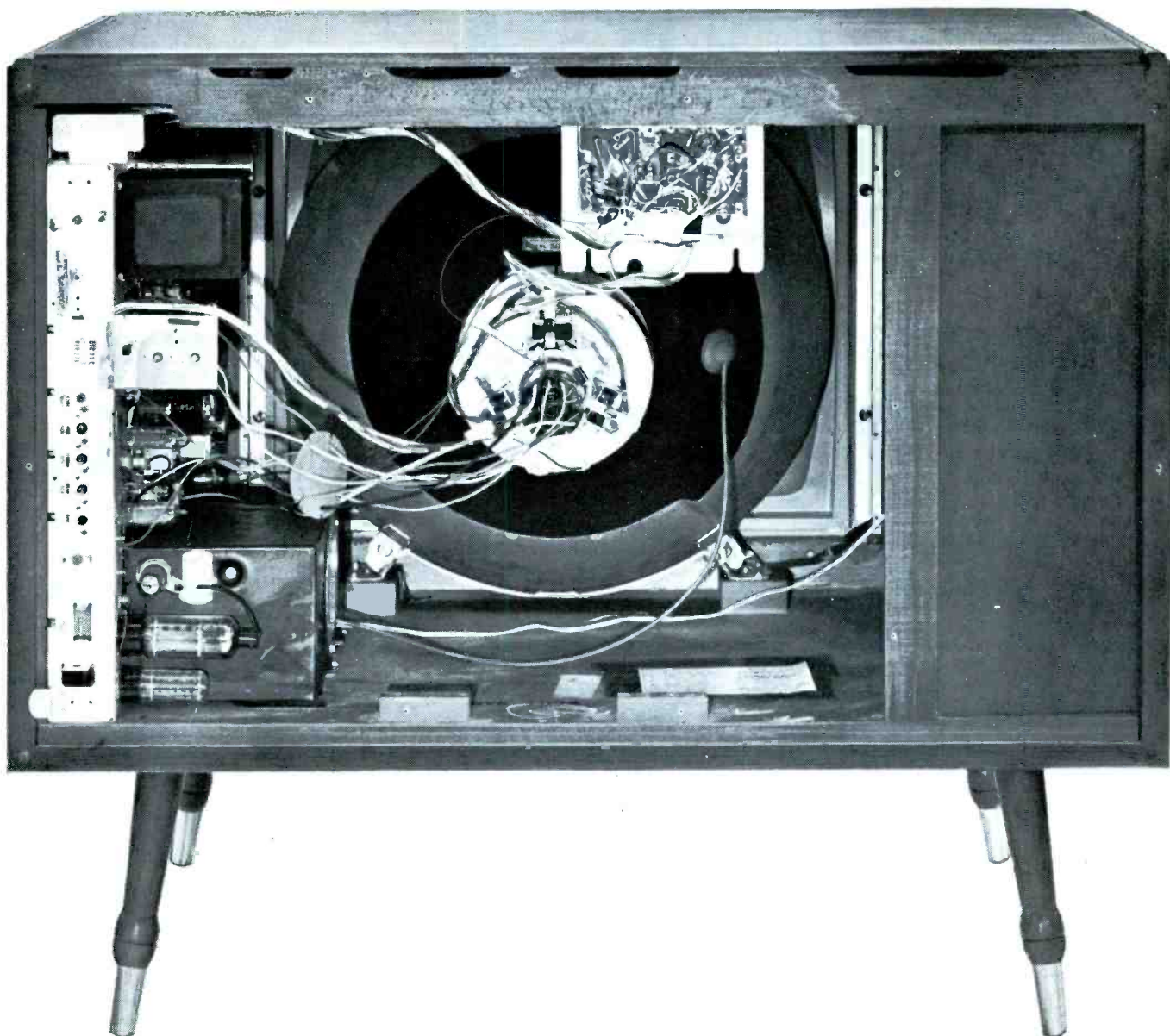

control grids of V2 and V3. These two regulators then cause a load-current change in the whole system that effectively restores the output voltage to its original value.

The bias section relies upon V5 for rectification and V6 and V7 for regulation. Note that the positive output terminal of the bias supply is directly con-

nected to the negative or common side of the main DC output circuit. Control R14 affords panel adjustment of the potential applied to the output terminals.

Two 6.3-volt windings on the power transformer make up the AC filament supply. Connections for series or parallel arrangements of these windings are illustrated right on the panel.

"Watts" Cookin'?

If you'd like to know whether an amplifier is "cookin' on the front burner" or not, try adding a touch of the "ingredient" pictured in Fig. 3 to your next troubleshooting recipe. The instrument shown here is the Model 260 AC Volt-

meter recently introduced by EICO, Inc. of Long Island City, N. Y. Useful in hi-fi and general audio work, the 260 is essentially an AC voltmeter and audio wattmeter. A single wattage scale and a direct-reading db scale pro-



Fig. 3. New EICO 260 meter reads rms volts and power in dbm or watts.

vide all power readings, since the unit has built-in compensation for various standard load impedances. As with all EICO products, the unit is available in either kit or factory-wired form.

Specifications are:

1. Power Requirements—105/125 volts, 50/60 cps; power consumption 15 watts; regulated supply fused and line-isolated; ON indicator on front panel.
2. AC Voltmeter—11 full-scale ranges of .01, .03, .1, .3, 1, 3, 10, 30, 100, 300, and 1000 volts rms; input impedance 2 megohms shunted by 15 mmf; frequency response flat from 10 cps to 150 kc, -3 db to 500 kc; accuracy $\pm 4\%$ of full-scale deflection; maximum input (AC + DC) 1500 volts.
3. Wattmeter—7 full-scale ranges of .15, 1.5, 15, and 150 milliwatts, and 1.5, 15, and 150 watts; internal loads of 4, 8, 16, and 600 ohms provided, with maximum power rating of 40 watts for 4, 16, or 600 ohms, and 80 watts for 8 ohms; maximum power for external loads 150 watts; frequency response flat from 10 cps to 100 kc; accuracy $\pm 5\%$ of full-scale deflection.
4. DB Meter—7 ranges from -30 db to +52 db, based on dbm standard (zero db equals 1 mw of AC power)

THE INDUSTRY'S STANDARD
Most Widely Used Today
by Professional Servicemen

**SAVE
CUSTOMERS
MAKE
MONEY**

FAMOUS DELUXE B&K CRT 440

For Black & White and Color

"Most valuable and useful" . . . "Wouldn't be without it" . . . "Pays for itself over and over again" . . . servicemen say. Quickly checks and corrects television picture tube troubles in a few minutes right in the home without removing tube from set. Gives new life to weak or inoperative tubes. Checks for leakage, shorts, open circuits and emission. Removes inter-element shorts and leakage. Repairs open circuits and low emission. Restores emission and brightness. Life Test checks gas content and predicts remaining useful life of picture tube. Makes new tube sales easier. Completely self-contained. Rich leatherette-covered carry-case. Net, **\$74.95**

CATHODE REJUVENATOR TESTER

TESTS AND REJUVENATES
all picture tubes at correct filament voltage from 1 to 12 volts

TESTS AND REJUVENATES
110° tubes and the new 19" and 23" tubes

TESTS AND REJUVENATES
color picture tubes. Checks each gun of color tube separately

UP-DATE YOUR B&K CRT WITH THESE ACCESSORIES

Subscribe to New Picture Tube Information Service

See Your B&K Distributor, or Write for Catalog AP18-R

Model C40 Adapter. For use with previous Models 400 and 350 CRT's—to test and rejuvenate TV color picture tubes and 6.3 volt 110° picture tubes. Net, **\$9.95**

Model CR48 Adapter. For use with previous Models 400 and 350 CRT's—to test and rejuvenate 110° picture tubes with 2.34, 2.68, and 8.4 volt filaments. Net, **\$4.95**

B&K MANUFACTURING CO.
1801 W. BELLE PLAINE AVE • CHICAGO 13, ILL.
Canada: Atlas Radio Corp., 50 Wingold, Toronto 19, Ont.
Export: Empire Exporters, 277 Broadway, New York 7, U.S.A.

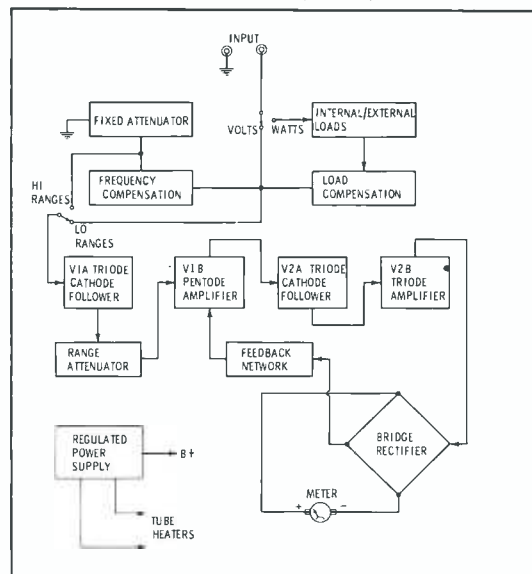

Fig. 4. The 260 is basically a VTVM with load and frequency compensation.

STOP AND SHOP

WEN POWER TOOLS



Look for this convenient display at your Electronic Parts Distributor (listed in the column at right). A full assortment of famous Wen power tools awaits your inspection. Step up to Wen quality—factory guaranteed to perform to professional standards.



FAMOUS "ALL SAW"

Best-selling power saw in the business! A souped-up UL "Industrially Rated" 1/2 HP saw—equally great for 6" logs and delicate pattern work. Cuts virtually any material quickly, cleanly. Complete with 7 blades, rip guide, circle cutter. \$44.95.



UNIVERSAL SABRE SAW

Lightweight and extremely versatile! Easily cuts 2 x 4's and fine scrollwork... any shape. Cuts wood, steel, wallboard, plastic, leather—anything normally cut with any saw. Powerful UL Approved motor. \$26.95.



2-SPEED DOUBLE-DUTY DRILL

No other drill like it! Big 3/8" geared chuck—2 speeds. Change from 1000 RPM (heavy duty) to 3000 RPM (delicate work) in seconds. 2 ball thrust bearings... oversize oilite bearings. Drill, polish, sand, grind, wire brush, mix paint—you name it. Most versatile tool in your workshop. \$29.95.



PROFESSIONAL SOLDER GUNS

The standard of the Electronic Industry for 10 years! No one—not even Wen—has been able to improve the Wen design. Quick heat, slim sturdy plastic housings. From feather-light 100 watts to 250 watt heavy duty. Guns and kits \$5.95 to \$15.95.

WORLD'S FINEST SANDERS



Choose from 3 models—a 1 straight-line fine-finish types... all with plenty of power. Perfect for re-finishing and new wood work. Never a scratch to mar a good surface. 14,400 strokes per minute by sanding surfaces up to 20 sq. in. \$13.95 to \$19.95.

WEN PRODUCTS, INC.

5810 Northwest Highway, Chicago 31, Ill.

- ALA., Opelika, Southern Electronics Corp.
- CALIF., Buena Park, Ford Electronics
- Burbank, Electronic City, Inc.
- Downey, Master Electronic Supply, Inc.
- Hollywood, Hollywood Radio & Electronics, Inc.
- Yale Radio Electric Co.
- Inglewood, Acorn Radio & Electronics
- Long Beach, Larry Lynde
- Los Angeles, Holtman Electronics-Parts Sales
- Figli's Radio Supply Co.
- Radio Products Sales, Inc.
- Shelley Radio Co., Inc.
- North Hollywood Arrow Sales, Inc.
- Hong Distributing Co.
- Oakland, Brill Audio Products
- Oxnard, Warsco Sales Co.
- Paramount, Elwyn W. Ley Co.
- Padena, Dow Radio, Inc.
- Riverside, Electronic Emporium Corp.
- Sacramento, Lombard's Electronics
- Radio Television Products, Co.
- San Carlos, Fortune Electronics
- San Diego, Southland Electronics Inc.
- San Francisco, Market Radio Supply Co.
- West Coast Radio & Electronics
- San Jose, Dealer Electronic Corp.
- Schad Electronic Supply, Inc.
- Santa Ana, Arrow Electronics, Inc.
- Seaside, Mat's Electronics Supply
- Tempe City, G & M Wholesale Electronics
- Torrance, Torrance Electronics
- West Covina, West Covina Wholesale Electronics
- COLO., Denver, Fistell's Electronic Supply Co.
- Mountain States Electric Supply
- CONN., Hartford, Del Padre Supply of Hartford
- D.C., Washington, Electronic Wholesalers, Inc.
- FLA., Pensacola, Grice Electronics, Inc.
- Tallahassee, Peard Electronic Supply, Inc.
- GA., Atlanta, Southeastern Radio Parts Co.
- Macon, Peard Electronic Supply, Inc.
- ILL., Aurora, Nationwide—W. J. Electronics
- Berwyn, Nationwide—W. J. Electronics
- B-B & W, Inc.
- Champaign, York Radio and Television
- Chicago, Allied Radio Corp.
- Arthur Nagel Inc.
- Bowman Electronic Supply Co.
- Nationwide—W. J. Electronics
- Phico Dist., Inc.
- Forest Park, Allied Radio Corp.
- Kankakee, York Radio and Television
- Oak Park, Melvin Electronics, Inc.
- Skokie, E & H Electrical Distributors
- Springfield, York Radio and Television
- Waukegan, Nationwide—W. J. Electronics
- IND., Evansville, Geo. C. Mettler Co.
- Gary, Allied Radio of Indiana
- Nationwide—W. J. Electronics
- Hammond, Tri-City Electric Co., Inc.
- Nationwide—W. J. Electronics
- Indianapolis, Graham Electronics Supply
- Radio Distributing Co.
- Van Sickle Radio Supply Co.
- IA., Fort Madison, York Radio and Television
- Sioux City, Duke's Radio Co.
- Molstad Distributing Co.
- Ottumwa, York Radio and Television
- LA., Baton Rouge, Davis Electronics Supplies
- Lafayette, Electro Technical Labs.
- Lake Charles, Wholesale Radio Equipment, Inc.
- New Orleans, Walther Bros. Co., Inc.
- Radio Parts Inc.
- Shreveport, Koelmay Sales Co., Inc.
- MASS., Lawrence, Alco Electronics
- MD., Baltimore, Revaco of Maryland, Inc.
- Silver Spring, Silver Spring Electronic Supply
- MICH., Detroit, Electronic Parts Co.
- MISS., Greenville, Delta Electronics Supplies, Inc.
- Pascagoula, Mays Electronics Supply
- MO., Hannibal, York Radio and Television
- Jefferson City, York Radio and Television
- Joplin, Russell Radio Electric Co.
- Kansas City, Walters Radio Supply, Inc.
- NEBR., Omaha, Omaha Electronics Co.
- N.H., Laconia, Laconia Electric Co.
- Nashua, Gate City Electric Co.
- N.Y., Albany, Seiden Sound, Inc.
- Binghamton, Stack Electronics, Inc.
- Bronx, W. Bergman Co., Inc.
- Buffalo, W. Bergman Co., Inc.
- Radio Equipment Corp.
- Hempstead, Standard Parts Corp.
- Rochester, Rochester Radio Supply Co.
- Syracuse, Morris Electronics of Syracuse, Inc.
- Utica, Associated Electronics Supply
- OHIO, Akron, The Sun Radio Co.
- Chillicothe, Buckeye Electronics Distributors, Inc.
- Columbus, Buckeye Electronics Distributors, Inc.
- Whitehead Radio Co.
- Coshocton, Wagner's Supply
- Dayton, Srepc, Inc.
- Slotts-Friedman Co.
- East Liverpool, United Electronics, Inc.
- Lancaster, Buckeye Electronics Distributors, Inc.
- Lima, Hutch & Son
- Mansfield, Wholesaling, Inc.
- Toledo, Lifetime Electronics
- Mainline Dist., Inc.
- Warren Radio Co.
- Warren, Rem Electronics
- Youngstown, Armes Electronics
- Glen Electronics
- PA., Butler, E and E Supply, Inc.
- Erie, Warren Radio, Inc.
- Harrisburg, Radio Distributing Co.
- Philadelphia, Radio Electric Service Co.
- Pittsburgh, Lafayette Radio Electronics
- M. Leff Parts Co.
- Radio Parts Co.
- Tarentum, Huston TV Parts
- Wayne, High Fidelity House
- TEXAS, Austin, Seivice Electronic Supply
- UTAH, Salt Lake City, Manwill Supply Co.
- VA., Portsmouth, Distributors, Inc.
- WASH., Seattle, F. B. Connelly Co.
- Seattle Radio Supply, Inc.
- W. VA., Beckley, Chemcity Electronic Dist., Inc.
- WIS., Appleton, Valley Radio Distributors
- Fond du Lac, Harris Radio Corp.
- Madison, Radio Distributors
- Satterfield Electronics, Inc.
- Manitowoc, Harris Radio Corp.
- Milwaukee, Allied Radio of Wisconsin
- Radio Parts Co.
- Electronic Enterprises, Inc.
- Portage, Satterfield Electronics, Inc.
- West Allis, Marsh Radio Supply
- Wisconsin Rapids, Satterfield Electronics, Inc.

FINE ENOUGH

to cut a human hair

STURDY ENOUGH

to cut 12-gauge copper wire

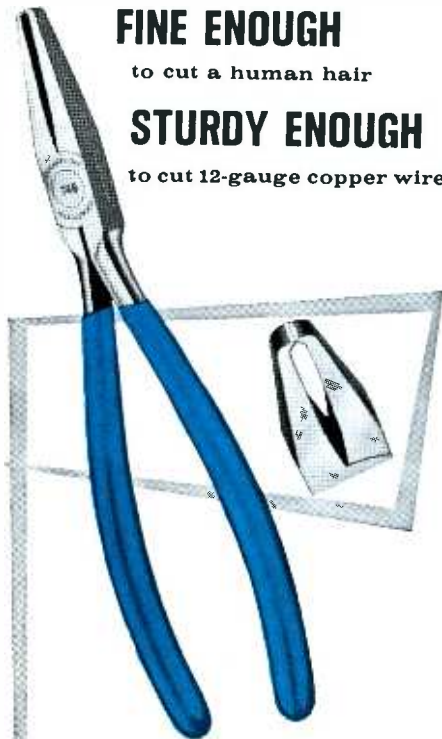

Specially Designed
CHANNEL LOCK[®]

**No. 748 Long-reach
End Cutter**

Here's the answer to your hard-to-get at wire cutting jobs... the CHANNELLOCK Long-Reach End Cutter. Gets into tight places you can't reach with any other cutter. Especially handy for electrical, radio, TV, Hi-Fi and electronics work. Precision-honed, specially hardened cutting edges. Long, blue-plastic coated handles. Top quality polished forged steel. Ask your tool supplier for a CHANNELLOCK No. 748 End Cutter. If he doesn't have one, ask him to order it for you.



Write for Catalog of
Complete Line of Pliers



#718 LONG-REACH FLAT-NOSE PLIER



#728 LONG-REACH DIAGONAL CUTTER



#738 LONG-REACH ROUND-NOSE PLIER

Channellock Pliers are made only by

CHAMPION DeARMENT TOOL COMPANY
Meadville, Pennsylvania

across 600-ohm load); meter scale -20 to +2, giving direct readings on 1-volt range of voltmeter and 1.5-mw range of wattmeter; other positions of range switch calibrated in number of db to be added or subtracted; internal circuit provides automatic dbm compensation for power-db readings taken across other standard impedances (4, 8, or 16 ohms); manual provides correction charts for other than standard loads.

5. Panel Meter—200-ua DC movement; 4½" face with 4 individual scale arcs (full-scale readings 1V, 3V, 1.5W, and +2db).

6. Size and Weight—8½" x 5¾" x 7¾", 6 lbs.

The 260 has only two front-panel knobs—a combination function and load selector on the left, and an 11-position range switch on the right. No test leads are supplied; instead, the two input terminals are universal binding posts suitable for pin or banana plugs, clips, or bare-wire connections. An extractor-type holder for the ½-amp line fuse is located on the rear apron of the case, while a calibration adjustment is reached through an access hole (covered by a removable button) on the right side.

The block diagram in Fig. 4 shows how the 260 is equipped to handle a broad range of power and voltage inputs. With the function selector in the VOLTS position, the internal-external loading provisions for power measurements are bypassed. The applied AC voltage is coupled to the grid of cathode follower V1A (the triode section of a 6BL8)—either directly or through a frequency compensator and fixed attenuator, depending on whether a high or low range is required for the measurement.

Meter-Minded?

Triplet Electrical Instrument Co., of Bluffton, Ohio, has introduced a new vacuum-tube voltmeter. The Model 850, pictured in Fig. 5, offers a wide selection of voltage- and resistance-measuring ranges, plus an easy-to-read meter with 7" scale and 200-ua movement. Scale markings are unusually large and clear; also, peak-to-peak AC voltages are indicated in red. The unit is housed in a black plastic case with etched aluminum panel.

Specifications are:

1. Power Requirements — 117 volts, 50/60 cps; power consumption 6 watts; one internal 1.5-volt cell (NEDA no. 14) supplied; OFF-ON switch and indicator provided on panel.
2. DC Voltmeter — 8 full-scale ranges of .5, 1.5, 5, 15, 50, 150, 500, and 1500 volts; input resistance 11 megohms; polarity-reversal switch and zero-center scale provided; accuracy ±3% of full-scale deflection.

The output of V1A is divided by a range attenuator and applied to the grid of amplifier V1B (pentode section of the 6BL8). It then passes through both sections of V2 (12AT7). The first half of this tube is a cathode follower serving as a buffer; the second is an amplifier. From V2, the voltage to be measured goes on to the meter rectifier. The DC output of this full-wave bridge produces meter deflection. The scales are calibrated in rms values of voltage or power for a pure sine-wave input. The calibrating control is incorporated in a degenerative feedback path between the rectifier bridge and the cathode circuit of V1B.

To measure power, an internal or external load with some standard value of impedance is switched in ahead of the voltmeter circuit. The function switch provides a choice of eight load positions. A load-compensating attenuator, ganged with this switch, adjusts the input to the voltmeter section so that the same wattage and db scales can be used for all load impedances.

Using an audio generator as a sine-wave source, I found it a very simple matter to check audio-amplifier characteristics with the 260. By substituting one of the internal loads for the speaker system of an amplifier, you can quickly obtain output wattage or db readings. Other applications of the 260 include testing audio amplifiers or individual stages for gain, frequency response, hum, and power consumption; checking resonant frequencies of speakers; and measuring outputs of phono cartridges, tape heads, etc. The 1-kv range of the voltmeter also makes the unit useful for reading exceptionally high AC potentials, such as secondary voltages of power transformers.

3. AC Voltmeter — 7 full-scale ranges of 1.5, 5, 15, 50, 150, 500, and 1500 volts rms; also 7 full-scale ranges of 4, 14, 40, 140, 400, 1400, and 4000 volts peak to peak; minimum input impedance .83 megohm;



Fig. 5. Meter face covers two-thirds of front panel in Triplet Model 850.

GE ELECTRONICS

ONE G-E 21FLP4 PICTURE TUBE REPLACES 13 TYPES

FILLS 25% OF YOUR REPLACEMENT NEEDS

The General Electric 21FLP4 just released. Here's the only picture tube you need for one out of every four replacements. It replaces 13 tube types. Thirteen replacement tubes you don't have to order—pick up—pay for—or carry in stock to meet your customers' requirements. It's almost like getting a 13-tube inventory in one picture tube! Quick availability for more of your replacement needs.

The General Electric 21FLP4 is a low-voltage electrostatic focus tube which does not require an ion trap magnet. Saves time and work on service calls and in the shop. The General Electric high-resolution electron gun and deep-cushion phosphor screen help provide the long-lasting, brighter picture your customers want.

The General Electric 21FLP4 replaces these 13 tube types:

21ALP4	21BAP4	21CBP4B
21ALP4B	21BNP4	21CMP4
21ATP4	21BTP4	21CVP4
21ATP4A	21CBP4	21CWP4
	21CBP4A	

Get full details on this 21-inch 90-degree "universal" replacement picture tube from your General Electric tube distributor. General Electric Company, Distributor Sales, Electronic Components Division, Room 8238B, Owensboro, Kentucky.

Progress Is Our Most Important Product

GENERAL  ELECTRIC

**A FEW
WILL DO**

**RELY ON
ROBINS
M/M
RECORDING AND
ERASE HEADS**

To service, upgrade or convert-to-stereo recorders made by these manufacturers:

Viking ■ Pentron ■ Wilcox Gay
 ■ Telectro ■ RCA ■ Revere ■
 Knight ■ Heath ■ Ekotape ■
 Bell ■ Columbia ■ Ampro ■
 Silvertone ■ Montgomery Ward
 ■ Masco ■ Packard Bell ■
 Olympic ■ Mitchell ■ Magnetic
 Recording Industry ■ Philco ■
 Capitol ■ Bell & Howell ■ Air
 Castle ■ Amplifier Corp. ■
 Sonograph ■ Symphonic ■
 Stereophonic ■ also plus heads
 for Wollensak and Revere models
 —38 U. S. manufacturers—200
 individual models.

Replace, upgrade, convert with these precision recording and erase heads. In most cases these heads, manufactured by Michigan Magnetics, are the original equipment supplied with the recorders.

Available at your Robins distributor. **FREE**—Robins M/M Tape Recording Head and Reference Guide, write:

ROBINS INDUSTRIES CORP.

Flushing 66, N. Y.

frequency response 15 cps to 3 mc (to 250 mc with RF probe); accuracy $\pm 3\%$ of full scale; db conversion chart provided in manual.

4. Ohmmeter—ranges R x 1, 10, 100, 1K, 10K, 100K, and 1 meg; center scale 10; zero and ohms adjustments provided on front panel.
5. Optional Accessories — high-voltage and RF probes; leather carrying case.
6. Size and Weight — $6\frac{3}{8}'' \times 7\frac{5}{8}'' \times 3\frac{3}{4}''$, approx. 5 lbs.

When I unpacked the 850 for examination, I found an altogether new look in Triplet meters. Instead of having a tall, narrow case and only one large selector knob (as in previous models), this VTVM is wider than it is high, with two main controls. The one at the left is a function selector having five positions (OFF, AC, -DC, +DC, and OHMS); at the right is a range switch with eight different positions. The instrument may be set upright on the bench or else operated in a flat position, resting on four rubber feet attached to the rear panel; it can also be tilted back about 65° by using its pivoted handle as a support.

Only one test cable is employed for all measurements. This probe, which is connected to the Model 850 through a coaxial jack, is a very slim unit with a thumb-operated slide switch for selecting either AC/ohms or DC operation. A separate ground lead is permanently attached to the meter.

Some of you who are not too familiar with meter circuitry, but realize that VTVM's use DC meters, have shown interest in learning exactly how these instruments measure AC voltages. To clear up this point, let's examine the AC input circuit of the Model 850 (Fig. 6). Note that the isolation resistor in the probe is bypassed for AC operation, and that DC blocking capacitors are placed in series with the applied voltage. The two diode sections of a 6AL5 rectify the input signal and produce a DC output proportional to the peak-to-peak value of the AC. This output is then applied to a voltage-divider network, where a certain portion—depending upon the range selected—is tapped off and fed to the grid of a triode stage in the measuring circuit.

In this conventional circuit, employing a 12AU7, the meter movement is con-

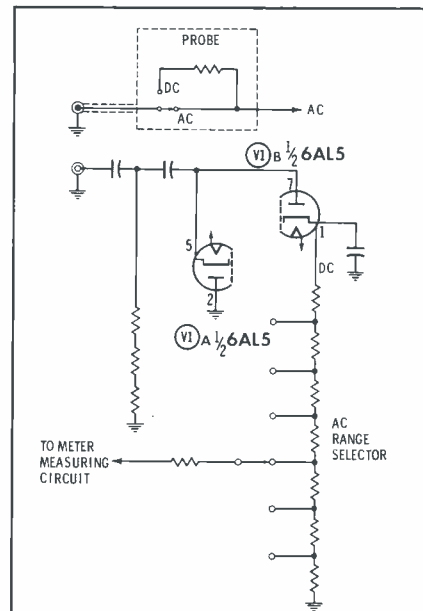

Fig. 6. AC-to-DC conversion circuit of the new Triplet Model 850 VTVM.

nected between the two cathodes. The DC bias change on one grid, produced by the rectified voltage being measured, causes unequal conduction in the two triode sections. This results in a difference of potential on the cathodes and likewise across the meter terminals. Deflection of the meter is calibrated so that indications of AC voltages are read directly on the appropriate scale.

Always keep in mind that an instrument of this type actually measures peak-to-peak values of AC inputs. The rms values on the meter scale are merely calculated from peak-to-peak results obtained with pure sine waves.

Peak-to-peak measurements afforded by the Model 850 make the meter useful for checking the amplitude of non-symmetrical waveforms such as video, sync, and sweep signals. Through several experiments in the lab, using typical TV waveforms, I found the peak-to-peak readings on the meter even more accurate than many obtained by using a scope and separate calibrating voltage. The loading effect of the meter will, of course, vary with the signal frequency and the impedance of the circuit under investigation; however, I found that attenuation due to loading seldom exceeded 5% of the total amplitude. ▲

PRECISION TUNER SERVICE
 P. O. BOX 272 1200 S. WALNUT ST.
 BLOOMINGTON, IND. EDISON 99653

7.50
 V or U
COMBO PLUS
9.95 POSTAGE

6 MONTH WARRANTEE

All Types T.V. Tuners Cleaned, Repaired and Aligned to Factory Specifications. Same day in shop service on most Tuners. Price Includes Minor Parts, Major Parts at Cost Price. We use Original Parts if possible. State Make Model and Enclose all Parts and Tubes. Pack Well and Insure.

ALSO HAVE LARGE STOCK OF EXCHANGE TUNERS, WRITE FOR TYPES AND PRICES.

NOW! NATIONAL ADVERTISING SUPPORT FOR THE THOUSANDS OF MEMBERS IN THE "PEET" (PHOTOFACT-EQUIPPED ELECTRONIC TECHNICIAN) PROGRAM!

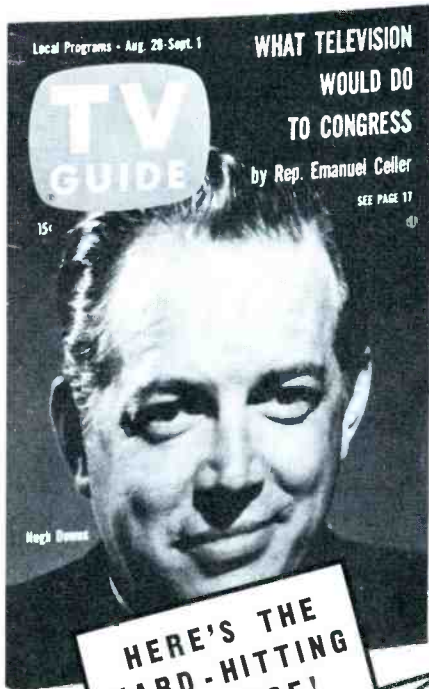

HERE'S THE
HARD-HITTING
MESSAGE!

for reliable
TV-RADIO
SERVICE
CALL THE MAN
YOU CAN TRUST



call a PHOTOFACT-EQUIPPED ELECTRONIC TECHNICIAN (PEET)
he understands your set best because he owns the Sams Photofact Service Data Library
he's a qualified member of the nationwide Fair Practices PEET Program
Call your nearest PEET Technician. If you can't locate him,
write for his name to Howard W. Sams & Co., Inc., Indianapolis 6, Ind.

FIRST AD BREAKS OCTOBER 21, 1961, IN
TV GUIDE America's biggest-selling weekly publication, reaching more than 7,500,000 TV families . . . an ad each month, every month for a full year . . . to bring the "PEET" Program to the attention of the American public . . . to build dynamic support and demand for services of "PEET" members. There's never been a consistent national ad program like this for the electronic servicing profession . . . with so many valuable tie-in promotional aids available (shortly to be released to the thousands of present "PEET" members)!

NOW MORE THAN EVER IT PAYS TO BE A MEMBER
IN THE "PEET" PROGRAM!

HERE'S HOW TO APPLY FOR "PEET" MEMBERSHIP

If you now own a PHOTOFACT Library, or have a Standing Order Subscription to PHOTOFACT, you can apply at once for membership in the powerful "PEET" Program, designed to build prestige and business for the Service Technician who qualifies. Ask your Sams Distributor about "PEET" or write to Howard W. Sams.

**SEND COUPON
TODAY!**

HOWARD W. SAMS & CO., INC. Dept. 7-KP1
2203 E. 46th St., Indianapolis 6, Ind.

Send me full details on the "PEET" Program, designed to build prestige and business for the Service Technician who qualifies. Include full information on the Easy-Buy Plan and Free File Cabinet deal.

I'm a Service Technician: full-time: part-time

My Distributor is: _____

Shop Name: _____

Attn: _____

Address: _____

City: _____ Zone: _____ State: _____

**20,000
VOLTS
DIELECTRIC
STRENGTH**

ACTUAL
SIZE

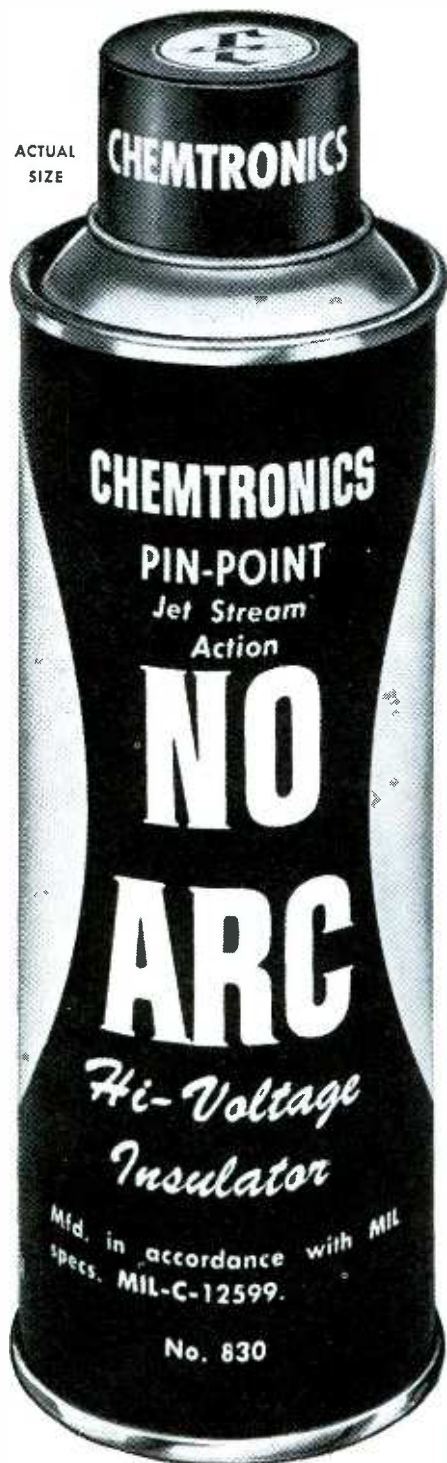

USES THE NEW PRINCIPLE OF
JET-ACTION
NOT A SPRAY!



WRITE FOR LITERATURE

CHEMTRONICS Inc.
870 East 52nd Street, Brooklyn, 3 New York

**SERVICE
DEALER
ADVERTISING
PROGRAM**

You can keep your fall advertising program swinging along by using a wide variety of ads to keep folks guessing about what you'll come up with next. If your promotional plans call for newspaper advertising, change ads every issue and repeat them every so often to obtain the best results. The whimsical cartoons featured in all of this month's ads will draw fresh attention to each new message.

Check with your printer to see if you should order newspaper mats (\$1.75 per set of 5), reproduction proofs (\$1 per set), or both (\$2.50). Then, fill in the handy coupon on page 90 to order either this month's selection or the entire program of 60 ads. (With the latter, you receive a comb-bound book of proofs.) To be sure of getting your ads in time for your promotion, mail the request as early as possible.

ES-44 1 7/8" x 5"

No punches are pulled in this message, which jabs at the "sore spot" of dissatisfaction with slow TV repairs — and promises prompt service from you.



TV NEUROSIS



PUGNACITY

The way to kill
TV Repair Men who
steal up a lot of
time, keep your
set in bad shape,
for prompt, reasonable prices

TV REPAIR
call ME 0-0000
YOUR NAME
ADDRESS

NO HOCUS-POCUS
IN OUR METHOD OF
TV REPAIR

You guarantee to
increase when
you use the
latest
electronic
equipment
and data.
For prompt TV
service call

ME 0-0000
YOUR NAME
ADDRESS



ES-7 3 3/4" x 2 5/8"

Here's a humorous way to remind people that you're a wizard at TV servicing because you use professional equipment and techniques.

ES-54 1 7/8" x 4 1/4"

This ad, pitting kids against parents in an all-too-familiar viewing debate, is sure to help you increase used-set sales.



THE ONE WANT TO WATCH

Lasso

THE OTHER WANT TO WATCH

Whodunnit

How a good parent had and those

YOUR NAME
PHONE NO. - ADDRESS

PROMPT, REASONABLE PRICES

ES-56 1 7/8" x 5 1/4"

Alerted by this "poster," set owners are encouraged to call you to cast out the "devil" responsible for short circuits.



WANTED
FOR TV COB!

"Shanty" Circuits
Armed with high voltage
approach with extreme
caution. Place the devil with you.
If not seen in outlet call
ME 0-0000

YOUR NAME
ADDRESS

does your
HI-FI
have

TIRED WOOFERS?

We'll see complete facilities for hi-fi
car, car radio and TV repair

YOUR NAME - ME 0-0000
ADDRESS



ES-60 3 3/4" x 2 5/8"

This is no "shaggy dog" story; it gets right to the point and tells prospective customers of your complete facilities for hi-fi, radio, car radio, and TV service.

TV TUNERS * **REBUILT OR EXCHANGED**

* ALL TYPES

\$9.95 Including all parts and labor
(except broken wafers—billed at cost!)

- Normally shipped same day received
- 90 day full guarantee
- U/V combinations \$17.95

FREE—If Mailing carton sent to you on request

Phone REpublic 3-9189

L. A. TUNER EXCHANGE

4511 West Jefferson Blvd.
Los Angeles 16, California

So Compact...



X-10

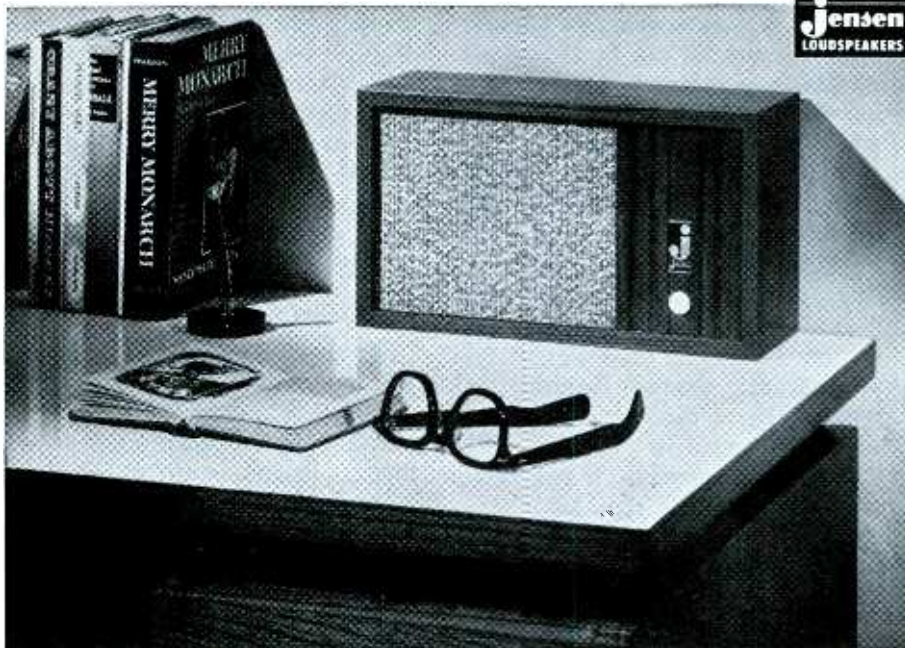

A startling achievement—an ultra-compact (7¼" H, 13" W, 4⅝" D) 2-speaker system capable of sound you'd expect from a much larger unit. Volume control on front. Perfect for FM Multiplex, very low cost stereo, other-room extensions.

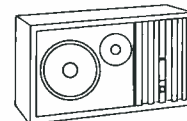

X-10 2-speaker 2-way system for use with amplifier having 4, 8, or 16 ohm output. Power rating 6 watts. Adequate room sound with 1 watt to speaker. In Oiled Walnut.....\$29.75

So Big in Sound...



TF-2 TF-3

Strikingly beautiful compact bookshelf systems—perfect for every stereo or mono hi-fi need. Recent "blindfold" tests by audio experts proved a preference for the TF-3 and TF-2 over "rated" systems costing much more. Make your own careful comparison. You will be delighted with such big sound in small space.

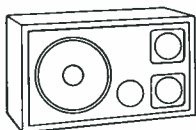
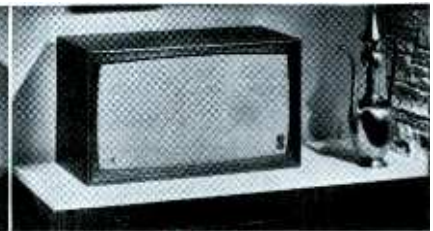
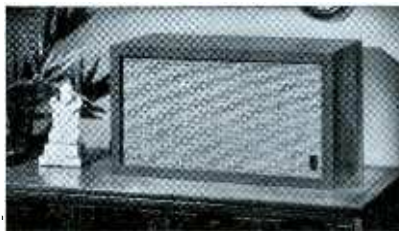
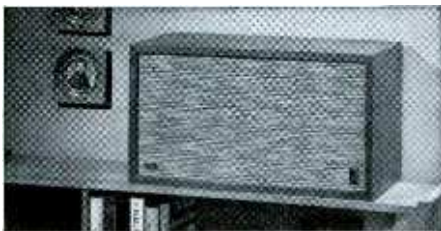

TF-2 3-speaker 2-way system. Full size Flexair* woofer for distortion-free bass response, plus two special direct radiator tweeters giving extended smooth highs. 13½" H, 23¼" W, 11¼" D. In Oiled Walnut.....\$79.50 Unfinished Hardwood.....\$64.50

TF-3 4-speaker 3-way system. Covers full frequency range with Flexair* woofer in Bass-Superflex* enclosure, two coloration-free midrange units, and the sensational Sono-Dome* Ultra-Tweeter. 13½" H, 23¼" W, 11¼" D. In Oiled Walnut.....\$99.50 Decorator Styling.....\$109.50

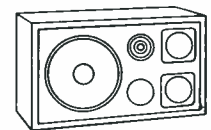

Unfinished Hardwood.....\$79.50



jensen MANUFACTURING COMPANY
DIVISION OF THE MUTER CO.

6601 S. Laramie Avenue, Chicago 38, Illinois

In Canada: Renfrew Electric Co., Ltd., Toronto

In Mexico: Universal De Mexico, S.A., Mexico, D.F.

*T.M. Reg.

NEW SAMS BOOKS

JUST OUT—THIRD EDITION OF
THE FAMOUS HOWARD W. SAMS

Tube Substitution Handbook

Still Only \$1.50

- ★ Completely Updated and Fully Revised
- ★ Includes Over 800 New Substitutions



Latest edition of the book you'll find useful every day. Contains only DIRECT substitutions. Now includes 5,234 substitutions (808 more than in prior volume). Lists 2,759 substitu-

tions for 1,687 receiving tube types. Shows 224 industrial and 602 European substitutes for American receiving types; 513 American for European receiving types; 465 picture tubes with 1,136 substitutes. Includes useful data on tube substitution. A "must" for every tube caddy and service bench. 96 pages; 5 1/2 x 8 1/2". Only **\$1.50**

New On Industrial Electronics!

Using The Oscilloscope In Industrial Electronics

by Middleton & Payne



Explains how to use scope to test industrial equipment such as thyatron controls, ignitrons and controls, saturable reactors and magnetic amplifiers, radar equipment, automotive ignition systems, transistorized controls. First 4 chapters cover basics: scope information capability, operating features, characteristics, general use in industrial electronics. Ten other chapters discuss waveform photography, lab applications, scope maintenance and calibration, etc. Includes handy scope specifications charts as well as numerous waveforms showing normal and abnormal operation. 256

pages, 5 1/2 x 8 1/2". Only **\$4.95**

Industrial Transistor & Semiconductor Handbook

by Robert B. Tomer



Now available—latest, most complete data on Industrial semiconductors, their characteristics, circuit-design procedures, typical applications. First 4 chapters on semiconductor physics, general characteristics, circuit fundamentals, ratings and measurements. Other chapters discuss applications: diodes, industrial

control, power converters, communications, unusual devices, thermoelectricity in solar-energy conversion. Special chapter discloses advanced semiconductor manufacturing techniques. Final chapter describes new developments, such as thin-film and integrated circuits, high-density packaging, microelements, etc. Appendix contains transistor parameter symbols and definitions, plus methods for determining thermal stability of transistor circuits. The up-to-the-minute book on semiconductors. 256 pages; 5 1/2 x 8 1/2". Only **\$4.95**

NEW! VOL. 9 SERVICING TRANSISTOR RADIOS!
Just out—covers 47 models produced in 1960. Complete PHOTOFACT® servicing data. 160 pages; 8 1/2 x 11". Only **\$2.95**

HOWARD W. SAMS & CO., INC.

Order from your Sams Distributor today, or mail to Howard W. Sams & Co., Inc. Dept. K-31
1720 E. 38th St., Indianapolis 6, Ind.

Send me the following books:

- Tube Substitution Handbook Vol. 3 (TUB-3)
- Using the Scope in Industrial Electronics (OSM-1)
- Indust. Transistor & Semicond. Handbook (ITT-1)
- Servicing Transistor Radios (TSM-9)

\$.....enclosed. Send Free Book List

Name _____

Address _____

City _____ Zone _____ State _____

IN CANADA: A. C. Simmonds & Sons, Ltd., Toronto 7

(outside U.S.A. priced slightly higher)

Schoolroom TV

(Continued from page 37)

flectors are good here, since almost all their gain is in the vertical plane. They have a flat, wide pattern—very narrow up and down, but broad from side to side.

Point A is somewhat of a stinker, since the aircraft can be in any direction from the receiving antenna, including straight up! It can be at any distance from 5 to 25 miles, and the lobes of the transmitting antenna itself can be cutting across the receiving antenna. This calls for a special kind of antenna, the turnstile—an omnidirectional type which receives equally well from any direction. Consisting of a pair of interconnected dipoles mounted at right angles to each other, this design is embodied in a familiar type of FM radio antenna. (If you need an antenna of this type for UHF, write the author for constructional details—there's too much verbiage involved to describe it in this article.) Installations under point-A conditions should also have excellent AGC, because the signal strength can change by 20 db (tenfold) during each orbit.

Single-Set Installations

Even if only a single receiver is being connected to an antenna, many precautions must be taken to compensate for the extreme attenuation produced by the transmission line on the upper UHF channels. Flat lead-in cable is unsatisfactory, since any moisture or dirt which collects on the insulation will produce a low-resistance leakage path between the conductors and will tend to short out the signal. This effect can be greatly lessened by using round, foam-filled 300-ohm

twin-lead of the same type commonly used in present UHF areas.

Here are several other pointers on minimizing signal losses: (1) Keep the lead run as short as possible; trim off all excess length. (2) Do not splice the cable. (3) Avoid running the lead-in within *three feet* of other antenna, phone, or power lines. (4) Use 7" stand-off insulators to keep the lead-in spaced well away from the building, and install no more stand-offs than necessary to provide secure support. (5) Do not crimp the stand-off "eyes" against the cable.

Distribution Systems

If more than just a few television sets will eventually be installed in a school, it is cheaper to install a signal-distribution system than to depend on an individual antenna for each set. The system converts the incoming signals to VHF before applying them to the various receivers. Thus, since only one master UHF converter for each channel is required, VHF-only receivers can be used in place of all-channel models at a saving of \$30 to \$35 per set. In addition, the system provides amplification which results in plenty of signal strength, in spite of multiple-set connections and long lead runs.

A system for the present MPATI setup consists essentially of two UHF antennas (one for each channel), two UHF converters of the fixed-tuned type, a distribution amplifier or amplifiers, cables, and tap-off devices. Coaxial cable is used everywhere except between the antenna and converter. This one connection is generally made with unshielded line (round 300-ohm lead) to minimize UHF signal losses.

Western T.V. Tuner Rebuilders

VHF or UHF ALL MAKES

\$9.95

UHF

VHF

UHF-VHF COMB. \$17.50

90 Days Guarantee — 24 Hour Service

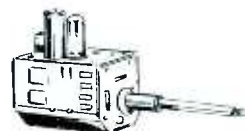

Prices are for servicing unutilated units. Missing, broken and damaged major parts charged extra at (low) net price.

TUNERS ENVIADOS POR CORREO DE LA REPUBLICA MEXICANA SERAN RECOGIDOS Y ENVIADOS CON TODOS LOS REQUISITOS ADUANALES.

WESTERN TUNER REBUILDERS

4130 El Cajon Blvd. San Diego 5, Calif.
ATwater 4-2733

Proved:

GENERAL ELECTRIC TV IS MORE RELIABLE THAN OTHER LEADING BRANDS

PROOF—A recent study of 5050 TV sets under service contract showed that General Electric TV needed 20% less service than the second best of the leading television brands.*

PROOF—The same study also showed that the average of other brands required 63% more service (factory faults requiring service inside set) than General Electric.*

*This study covers the first 90 days of use of new TV sets purchased in 1960. All sets included were under service contract to the Planet Electronics Corp., a prominent independent service company in New York City. The leading brands of television receivers were included. The results were tabulated and reported by Audits & Surveys Company, Inc., a leading research organization. If you wish additional information on this survey, write to General Electric Company, Room 112, Building #5, Electronics Park, Syracuse, N. Y.

What this means to you: Facts prove that once a General Electric television set is fixed, it stays fixed! Fewer repeat calls mean more free time for you to make more calls to new customers. Fewer repeat calls mean fewer irate set owners. Fewer repeat calls mean more customer satisfaction and an enhanced reputation for you. The word spreads about the quality of your work. Your reputation grows and so does your business.

Progress Is Our Most Important Product

GENERAL  ELECTRIC

TELEVISION RECEIVER DEPARTMENT, SYRACUSE, NEW YORK

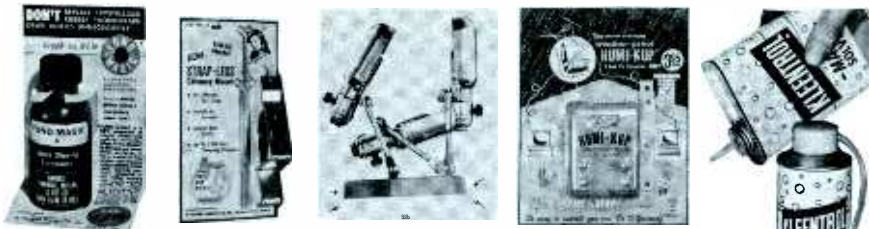

SHORT CUTS FOR SERVICE PROFITS!

FONO-MAGIC—a liquid compound of Special Rubber and precious carbide particles forms a live rubber coating on metal phono drive parts . . . stops slipping and dragging caused by crystallized rubber drive wheels. Contents are equivalent to the replacement of 100 idler wheels; will not wear off. dealer net . . . **\$1.95**

STRAPLESS CHIMNEY MOUNT—saves 90% of the time required for antenna installations . . . outlasts stainless type mounts. No chimney too large; installs on corner of buildings too. dealer net . . . **\$1.75**

MAGNA-LITE—superpowerful magnet clamps light to chassis, transformers, brackets, etc. Does away with flashlight servicing. 3-way swivel action puts light exactly where needed. net . . . **\$5.95**

HUMI-KUP 2 SET COUPLERS—hermetically sealed for outdoor installation; all inductive circuitry; skin packaged for self service sales. List **\$3.95.** dealer net . . . **\$1.95**

KLEENTROL MAGIC SOLVENT—approved by C.A.A.; contains no Carbon-Tet; non-flammable; will not harm finishes of wood, metal, or acetate parts. net (5 oz. spray can incl. injector tube) **\$1.25;** pint size **\$1.95 net.**

CARDIO MASTER—super powerful magnetic device designed to hold a portable transistor radio in the area of a car's windshield and make it operate as a car radio. List Price **\$4.95** dealer net . . . **\$2.97**

METAL STROBE—handy all metal speed determining tool that lasts a lifetime; 4 speed design. dealer net . . . **.99**

KLEENTROL TAPE—cleans oxide from heads of tape recorders without dismantling housing which surrounds heads. Process takes 2 min. List **\$2.69.** net **\$1.88**

Sold at better jobbers everywhere—Detailed literature upon request. Write Dept. P 10

R-COLUMBIA PROD. CO., INC. 2008 St. Johns Ave. Highland Park, Ill.



Dual antennas and converters are needed because both channels must be available at the same time. If local VHF or UHF stations are also to be viewed, they can be added to the system at slight additional cost.

Certain points essential to the acceptance of a system are checked off in Fig. 3, which shows a block diagram of a typical reception hook-up. Antenna requirements (at the top of the list) have already been discussed. When the best possible antenna arrangement has been made, it's time to determine what characteristics the UHF converter must have in order to maintain a good noise figure for the system. Primary factors are the noise figure of the converter itself, and the ratio of signal to noise in the VHF-channel output.

All installations need a converter with a good noise figure—as close to 10 db as possible. To take advantage of this noise figure, the lead between antenna and converter must be kept as short as possible. As previously mentioned, signal losses in transmission lines at UHF are terrible—about five times worse than on high VHF channels, and about eight times as bad as on low-channel VHF.

Bear in mind that if the noise figure is 10 db, the noise will be about 3.3 microvolts in the converter itself. Producing really good pictures (with a signal-to-noise ratio of 40 db) will require 100 times as much signal—or 300 microvolts. If a system receives 330 microvolts at the antenna, and uses a 50' tubular down-lead, about 6 db will be lost in the lead. This will leave the converter only 165 microvolts to work with, and will result in a signal-to-noise ratio of 34 db — or 50 to 1 instead of 100 to 1.

Antenna-mounted converter-mixer units are available to cut lead losses in situations such as this. The UHF oscillator in some models is on a separate chassis inside the building, with its output signal carried up to the mixer by cable.

Converters used should have crystal-controlled oscillators to insure frequency stability — a fact noted by the MPATI people in their recommendations. It is distracting to students if the fine tuning of the receiver has to be adjusted during a broadcast because of local-oscil-

WEBCOR IS BUILT for easy servicing



NEW! Technical information on all 1962 Webcor products available on subscription!

Service Manuals and Bulletins on all current models, plus literature on new models as they are released—from July 1961 to July 1962 . . . punched for filing in Webcor folder.

only \$5.00 per year's subscription

SUBSCRIBE NOW!

WEBCOR Service Dept., 912 W. North Ave., Chicago 22, Ill.
Enclosed is \$5.00 (by check , money order).
Please send a full year's subscription of Webcor technical literature to:

NAME _____
TITLE _____
COMPANY _____
ADDRESS _____
CITY _____ ZONE _____ STATE _____

Sarkes Tarzian

SILICON RECTIFIERS THAT MEAN FEWER CALL-BACKS FOR YOU



If you prefer them, you have lots of company!

Returns have just been tabulated from a mailing by Brand Name Survey, an independent research organization, to 23,000 service technicians in 36 states—all major market areas in the United States. More technicians like yourself prefer Sarkes Tarzian rectifiers than the next two most popular makes combined!

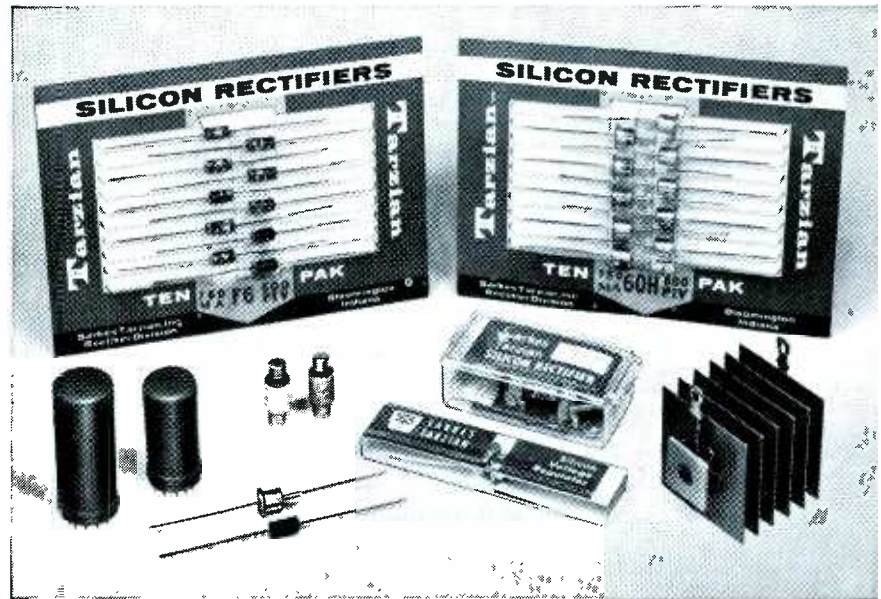

▲ Tarzian 400 and 600 volt F and H series units are available in handy Ten Packs or Doubler Replacement Kits, and in bulk; M150 and M500 units in Conversion Kits and in bulk. Nine standard tube replacement rectifiers replace over 95% of all popular vacuum tube rectifiers; S5347 replaces 6BW4 or 12BW4 in Citizen's Band radios. Four "condensed stack" selenium rectifiers, more efficient and SMALLER than before, now cover your 50 to 500 ma requirements.

Tarzian silicon rectifiers are available in the shapes, sizes, and specifications you need to do your work right—and quickly. They are available from distributors everywhere. And they combine the low price and high quality that is a Tarzian trademark.

Ask your distributor for a copy of the new Tarzian "Distributor Line" catalog, and make the performance of these preferred devices part of your good service.



SARKES TARZIAN, INC.

World's Leading Manufacturers of TV and FM Tuners • Closed Circuit TV Systems • Broadcast Equipment • Air Trimmers • FM Radios • Magnetic Recording Tape • Semiconductor Devices

SEMICONDUCTOR DIVISION • BLOOMINGTON, INDIANA

In Canada: 700 Weston Rd., Toronto 9 • Export: Ad Auriema, Inc., New York

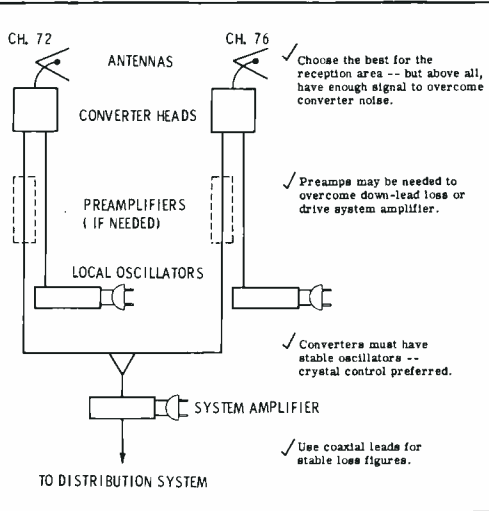

Fig. 3. Distribution-system components used for receiving MPATI programs.

lator drift.

If signal strength at the converter output is so low that less than 1000 microvolts are delivered to the input of the system distribution amplifier, then it's a good idea to re-amplify them right at the converter output, using a low-noise preamplifier. Units of this type are also available for mast mounting.

The distribution system itself is fairly conventional, except that the need for AGC may be more critical. This is best judged after checking signals "straight off the antenna"—if variations of 10 db or more are observed, the main amplifiers should be AGC-controlled.

The installer should find out what the school may be considering in the way of closed-circuit television; this field is becoming very active in schools, and educators are looking to the future. Officials of a particular school may want the wiring to conform to a CCTV plan not yet in effect. Special classroom outlets are available which allow the cable to be used as a CCTV camera input or output, as well as for feeding broadcast TV programs into the room. Systems using these outlets are laid out somewhat differently from conventional systems and are extremely flexible.

Once an installer has carefully determined what the school wants to do, he can then consult with a manufacturer of distribution-system equipment; engineering advice is usually free, but generally requires that the installer work through his local distributor. ▲

NEW CB VERSATILITY

WITH **EICO**®

New Deluxe Citizens Band Transceivers give you everything you need for fast, reliable, economical communication



770 Series

	kit	wired
Model 770: 117 VAC only	\$69.95	\$99.95
Model 771: 117 VAC and 6 VDC*	79.95	109.95
Model 772: 117 VAC and 12 VDC*	79.95	109.95

*Including Posi-Lock® Mounting Bracket (Pat. Pend.)

Front panel selection of one of 3 transmit crystals with continuous receiver tuning over all 23 CB channels, or a fourth transmit crystal with appropriate receiving crystal. Press-to-talk button on microphone; transmit-receive switching accomplished by high-quality relay with minimum capacity between contacts to prevent current leakage at RF frequencies. Superhet receiver with RF stage for high sensitivity & proper signal-to-noise ratio. 1750 KC IF strip for unequalled image rejection & freedom from oscillator "pulling" on strong signals. IF strip prealigned so that only "touchup" alignment without instruments is needed. Current metering jack in series in cathode circuit allows checking of input power to transmitter final & adjusting it to FCC limit. 13-tube performance (4 dual function tubes, 4 single function tubes, plus germanium diode). Adjustable squelch control (in addition to automatic noise limiter). Optimum adjustment to any popular CB antenna assured through use of variable pi network in output. AVC. 3" x 5" oval PM speaker. Supplied complete with 8 tubes & 1 transmit crystal (extra crystals \$3.95 each).

The entire transmitter oscillator circuit and RF final in every EICO transceiver, kit and wired, is premounted, prewired, pretuned, and sealed at the factory (about 3 hours of skilled labor, precision adjustments and testing), complying with FCC regulations (section 19.71, part d). This permits you to build the kit and put it on the air without the supervision of a commercial radiotelephone licensee.

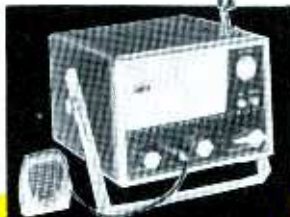

Standard 760 Series of CB Transceivers
from

Kit \$59.95 Wired \$89.95

You profit with EICO Test Equipment & Hi-Fi



DC-5 MC
5" Scope ±460
Kit \$79.95
Wired \$129.50



New Transistorized Stereo/Mono 4-Track Tape Deck
Wired Model RP100W \$399.95
Semi-Kit Model RP100K, Electronics in Kit form, \$299.95

An exclusive EICO product designed and manufactured in the U.S.A. (Pat. Pend.)



NEW FM-AM Stereo Tuner ST96
Kit \$89.95 Wired \$129.95 inc. FET



NEW 70-Watt Integrated Stereo Amplifier ST70
Kit \$94.95 Wired \$149.95
NEW 40-Watt Integrated Stereo Amplifier ST40
Kit \$79.95 Wired \$129.95

Over 80 products to choose from. Write for free Catalog PF 10 & name of nearest distributor. Most EICO distributors offer budget terms.

EICO Electronic Instrument Co., Inc. 3300 N. Blvd., L.I.C. 1, N.Y.
ADD 5% IN THE WEST © 1961

Export Dept., Roburn Agencies Inc., 431 Greenwich St., New York 13, N. Y.

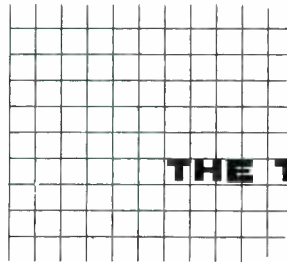

THE TROUBLESHOOTER

answers your service problems

Channel 5 Shrinks!

I'd appreciate your help on an Artone using a Trav-Ler Chassis 1053-69. Channels 2, 4, and 11 do fine, but when the set is tuned to channel 5, the picture pulls up about 3" from the bottom.

JIM'S TV SERVICE

Collinsville, Ill.

Since the picture shrinks only on channel 5, it sounds like tuner trouble. Check B+ to see if it drops drastically on chan-

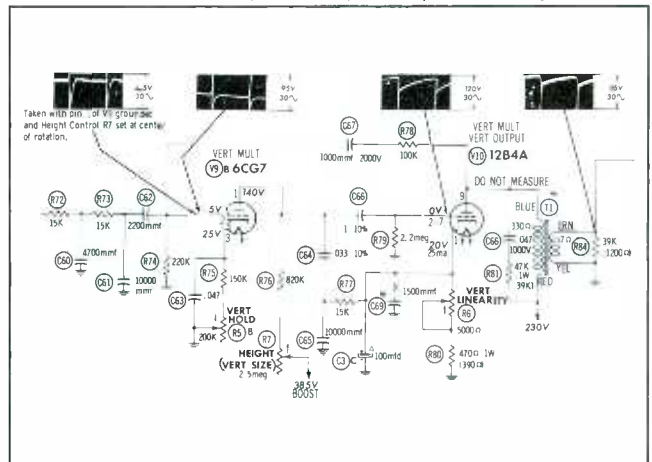

nel 5. If so, there's probably a short in the channel-5 section of the tuning wheel. Since channel 6 is not used in your area, try tuning its oscillator slug to channel 5. If you receive a full-sized picture, you'll know the tuner is at fault.

If the trouble persists, make critical voltage and waveform-amplitude measurements in the vertical circuits, checking to see if switching the tuner to and from channel 5 causes an appreciable change.

Warm-Up Roll

When a Philco Model 22D4151 is first turned on, the picture drifts down fairly rapidly. It slows down and stops after about 5 or 10 minutes. What would you do?

CARL H. MILLER

N. Wildwood, N. J.

Drifting vertical hold during warm-up can be caused by many different things. The components most likely to be causing your trouble are C70, R82, C71, R81, and temperature-compensating resistor R83. If you substitute for R83, be sure to use an exact replacement.

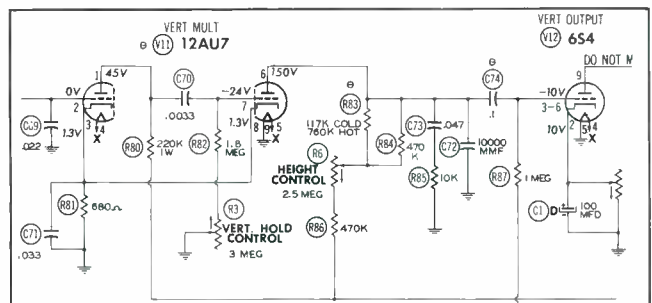

TRIM YOUR
INVENTORY
WITH

THE COMPACT TUNG-SOL ET* TRANSISTOR LINE



ET-1
Mixer/Oscillator
Converter PNP



ET-2
IF Amplifier PNP



ET-3
AF Amplifier
PNP-6V



ET-4
AF Amplifier
PNP-12V



ET-5
AF Amplifier
PNP-9V



ET-8
Mixer/Oscillator
Converter NPN



ET-6
AF Power
Amplifier PNP



ET-7
AF High Power
Amplifier PNP



ET-9
IF Amplifier NPN



ET-10
AF Amplifier
NPN-9V



ET-11
AF Amplifier
NPN-12V

You can reduce the number of slow-moving items in your inventory . . . increase profits . . . cut wasted service time with the Tung-Sol ET transistor line.

The compact Tung-Sol ET transistor line meets virtually all common radio service requirements with a handy group of well-packaged transistors that are built to the highest standard of reliability in the industry. You will get more customer satisfaction and fewer callbacks with reliable Tung-Sol transistors. **Packaged for fast selection . . .** each Tung-Sol transistor is packed in a

carton clearly marked with type number and application. **Warranted for superior performance . . .** Tung-Sol quality control assures peak performance and rugged long life for each production unit.

Priced for service business profits . . . more profit per service hour with lowered inventory and fast, easy type selection.

For full information on the Tung-Sol ET transistor line and Tung-Sol's profit-building sales support program, contact your Tung-Sol distributor, or write: Tung-Sol Electric Inc., Newark 4, N. J.



*ET for Entertainment—your guide to types specially developed by Tung-Sol for radio and TV replacement.

 **TUNG-SOL®**



The "Big Picture"

...informative shop talk from
Sylvania Field Service Headquarters

New, Easy-Service Board



...beats the
cracking problem

No need to handle this new chassis board with kid gloves! It's plenty tough—copper-bonded and double-sealed to withstand flexing, vibration and shock. Typical of the quality in the new '62 Sylvania TV sets.

No wiring "hangovers," either. Each and every new Sylvania chassis board is the spittin' image of the lab master—precision produced by automatic machinery designed and built by Sylvania specifically for the job. No more cold solder joints—the exact soldering temperature is automatically maintained. A new solder "resist" coating prevents solder from being applied except where it's supposed to go—on the connections only. They're clean connections, too—whiskers just automatically don't happen. Not with Sylvania TV.

New simplicity of service, too. Parallel circuitry makes testing faster and easier. Tube pin numbers, along with parts numbers and testing points, are clearly marked on top of the board, and the color-coded "road map" is a cinch to follow. Also, this horizontal chassis won't topple on your bench—and its clean design assures easy access.

You'll see, too, that this new board is sealed against humidity—as are the plastic encapsulated capacitors and the Mylar-insulated high voltage transformer and new Flexi-core power transformer. Just another example of the quality built into this service-designed chassis.

SERVICE TIP OF THE MONTH

Have a good service tip you'd like to pass along? Send it to us in 50 words or less. If it's used in this column, you'll get \$10.00 and the credit. While you're at it, send us your comments on the new GT-555 chassis. Sylvania Field Service Headquarters, Sylvania Home Electronics Corp., Batavia, N.Y.

SYLVANIA

SUBSIDIARY OF

GENERAL TELEPHONE & ELECTRONICS



Radio Switcheroo

A customer wants to take the radio out of a truck which has the negative battery post grounded and install it in another truck with a positive battery ground. The radio is a 12-volt model with a vibrator. What changes would have to be made?

WALTON A. VONMAONEN
Lynnville, Iowa

None; since the radio does not have a transistor, you can install it in any automobile or truck regardless of which battery terminal goes to ground. None of the 12-volt auto radios were designed with a synchronous vibrator; therefore, polarity doesn't make any difference.

Station Repeater

A Motorola Model 52MIU portable picks up our two local stations (1290 and 1440) all up and down the dial. However, even the strong New York stations won't come in anyplace. There must be a simple explanation, but it escapes me.

S. ANDERSON
West Islip, N.Y.

Chances are the oscillator section of the 1R5 isn't working. Vary the tuning gang and measure the oscillator grid voltage at pin 4. It should range from -5 to -15 volts if the oscillator is working. Be sure to try a replacement 1R5 and make sure it is receiving the proper filament and B+ voltages. Oscillator coil L2 may be defective if everything except the negative voltage on the grid checks out OK.

Eats 6U8's

An RCA Chassis KCS104 knocks out a 6U8 sync separator-AGC keyer every two or three months. The filament doesn't go bad; the AGC section just quits working. There doesn't seem to be anything wrong in the circuit, so what can I do?

EUGENE ACOSTA
Bronx, N.Y.

Repeated failure of the 6U8 in the AGC keying and sync separator circuits in some of these receivers has always been a problem. It results from damage to the tube by the applied pulses, and seldom indicates a defect in the receiver. The best solution is to use one of the newer tubes designed for this application, such as a 6EA8 or 6GH8. The latter is possibly the best replacement in this particular stage.

5642 Query

Are the two 5642 tubes in a Sylvania Model 7140MA supposed to glow a purplish color? This is my first experience with these tubes. The set has a very faint picture, but I don't know whether to suspect the tubes or not.

THOMAS C. SHIPLEY
Hyattsville, Md.

It isn't unusual for these tubes to have a slight purple glow during normal operation. However, any excess glow would indicate higher-than-average gas content. In order to tell whether or not the rectifiers are causing the dim picture, measure the high voltage. If it is below normal, you can suspect trouble in the high-voltage doubler circuit.

Cartridge and Needle Replacement

(Continued from page 39)

arrangement, are removed as illustrated in Figs. 2A and 2B. As in A, you first push the retaining spring back with the tip of your finger; then, by holding the butt end of the needle, carefully lift it out of the cartridge as shown in B. A couple of other spring mountings are shown in Fig. 3. To remove the dual-type needle shown in A, the button on top of the tone arm is held down; then the needle assembly is turned at a right angle to the cartridge, and slid forward and out. The button is also depressed while a new needle is being put in. Make sure that the tips on a new needle are properly positioned to conform with the operating indications on the button. You can remove the needle shown in Fig. 3B by holding the butt end of its shank between your fingertips; pull it to one side and out from under a retaining spring. Follow these instructions in reverse order to install a new needle.

Another needle-replacement job that may take a little "doing" is illustrated in the drawings of Fig. 4. Here, the cartridge must first be removed and disconnected from the tone arm (Fig. 4A). With a small wrench, the hex nut on top of the cartridge is then removed (Fig. 4B). The needle is now free to be lifted out.

Needles in some of the newer stereo cartridges are held in only by friction—but in a different manner from the vertical shank needles. In most cases, you'll find it easier to change the needle if you unplug

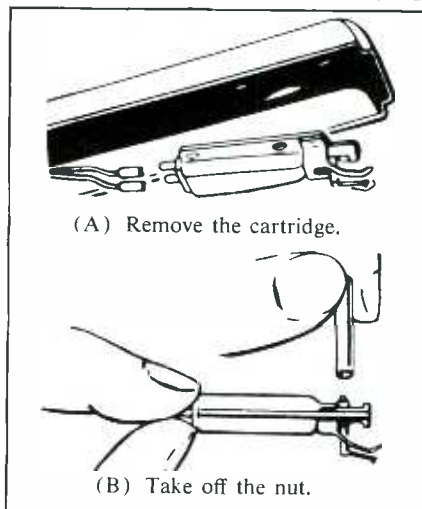

Fig. 4. RCA hex-nut mounting.

BOUGHT ANY GOOD
grid leaks LATELY?

CRL POTENTIOMETER
NON-INDUCTIVE
No. 116 (400 ohms) \$1.75
No. 115 (2000 ohms) \$2.00

CRL GRID LEAK
VARIABLE
No. 106 (without resistor) \$1.00
No. 107 (with 500K resistor) \$1.85

YOUR POTENTIOMETER SHOULD BE NON-INDUCTIVE
Induction interferes with and chokes the free passage of the delicate high frequency currents. You can't get the best results unless you get rid of this induction.

C.R.L. Potentiometers are absolutely non-inductive—the resistor is not wire but a strip of graphite protected against wear by a disc over which the shoe passes. Adjustment is noiseless through an infinite number of steps.

The Non-Inductive C.R.L. makes possible the proper biasing of the radio frequency amplifying tubes to insure the best results.

USE A GRID LEAK THAT HELPS YOUR SET
The wide unbroken range of adjustment through 900 degrees—2½ turns of the knob provides maximum sensitivity and allows you to accurately secure the exact resistance value you desire in your detector tube circuit.

The resistance value remains where set until the knob is again turned. Adjustment is secured not by rubbing but by the change in area of contact between the graphite impregnated fabric strip and the spring plate.

Adjustment is therefore stepless and noiseless over the complete range from ½ to 5 megohms.

CENTRAL RADIO LABORATORIES
MILWAUKEE, WIS.

301 - 16th STREET

1924 ad courtesy of Melvin Leibowitz, Delaware Electronics Supply Co., Inc., Wilmington, Delaware.

you (and **Centralab**[®])
have come a long way since

1924!

If you worked on radios 38 years ago, you probably used the CENTRALAB grid leak that was advertised in the 1924 *Citizen's Radio Call Book*. It was a fine product in its day—but its day has passed, and CENTRALAB no longer makes it.

Instead we have a complete line of products that you need *now* for servicing radios, television sets, audio and industrial equipment. When you think about controls—or switches—or ceramic capacitors—or **PEC**[®] packaged circuits, you naturally think of the CENTRALAB line, renowned for quality and completeness.

Ask your distributor for your free copy of the latest CENTRALAB catalog—your guide to the finest in electronic components.

G-6148S

Centralab[®]

THE ELECTRONICS DIVISION OF GLOBE-UNION INC.
942K EAST KEEFE AVENUE • MILWAUKEE 1, WISCONSIN
In Canada: Centralab Canada Ltd., P.O. Box 400, Ajax, Ontario

ELECTRONIC SWITCHES • VARIABLE RESISTORS • CERAMIC CAPACITORS

PACKAGED ELECTRONIC CIRCUITS • ENGINEERED CERAMICS

Most Unusual Watch Radio Ever Offered!

SAMPSON

DUALARM transistor watch radio



MODEL SC4000

DOES THINGS NO CLOCK RADIO CAN DO...
YET YOU CAN PUT IT IN YOUR POCKET!

THIS is the watch radio idea brought to its finest fulfillment. The new SAMPSON SC4000 with its unique two-way alarm system is a blending of creative engineering and highest production standards... exquisite jewelcase styling and unusual performance exclusives. A uniquely pocketable combination, providing features and functions unprecedented in versatility, in efficiency, in intriguing customer appeal. Yet its modest price puts the new SAMPSON Dualarm into the hands of *everyone!*

Powered, Priced, Promoted to Your Customers!

National advertising as unique and compelling as the product itself. A complete package of SAMPSON Dualarm newspaper ad mats ready to run under Your Store Name. Plus distinctive displays, window streamers, "spec" sheets, and other powerful in-store selling materials. And through The Sampson Company and its more than 300 distributing and servicing points in the United States... you are assured full profit, prompt delivery, dependable service the year around.

"Synchro-Eye" Night Light

Flashes on when radio-alarm or electronic-signal sounds. Stays on with dependable glow till alarm-cycle is completed.

Exclusive Time-Selector

Simplifies time-setting with no eye-strain, no knob-fumbling. Just turn bezeled watch-rim till indicator is at desired time.

Exclusive Beaumont Swiss Watch Movement

Precision engineered, reliably accurate 32-hour timepiece. Easy-to-read, luminous dial with sweep-second hand.

Patented Automatic Dual-Alarm System

Turns itself on for 12 minutes, off for 6, then repeats with a 12-minute encore. Shuts itself off. Both radio and independent electronic-signal alarm work same way.

U. S. Patent Pending
Foreign Patent Nos. 13559, 12680

Exclusive "Slenderette" Cabinet

Gold-trim, high-impact cabinet a slim 2 3/4" x 4 1/4" x 1 3/16"—in choice of Black/White or Coral/White.

Advanced Superheterodyne Circuit

6 lifetime transistors in specially designed circuit provide unusual power, sensitivity and tonal quality for a radio so compact.

\$39.95 Suggested Retail Price

Beautifully GIFT-BOXED, complete with leather carrying case and all accessories, including batteries and earphone.

MORE FROM SAMPSON...



"Little SAMPSON 6" (Model S640) the extra sensitive, high performance transistor pocket portable, packaged in distinctive book-styled presentation box. \$19.95

SAMPSON Deluxe Table Radio (Model ST61) strikingly styled, 5-tube superheterodyne circuit, engineered to exacting specifications.

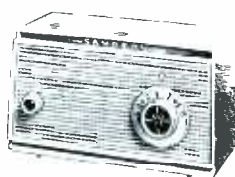

Model ST61

Write today for full details and the name of the Sampson distributor nearest you
products of **THE SAMPSON COMPANY** (EST. 1921)
ELECTRONICS DIVISION • 2244 SOUTH WESTERN AVE. • CHICAGO 8, ILL.

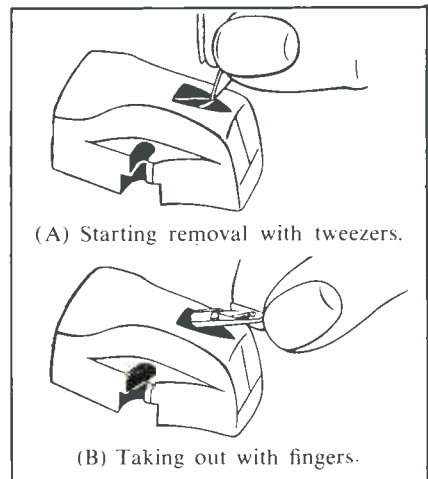

(A) Starting removal with tweezers.

(B) Taking out with fingers.

Fig. 5. "Pull-out, push-in" needles for some Electro-Voice and Shure units.

the cartridge from the tone arm. As shown in Fig. 5, you can pull out the needle-guard assembly by using a pair of tweezers or a pointed tool until you can reach it with your fingers. When installing the new unit, avoid coming in contact with the needle tip as you apply pressure to seat the assembly.

Cartridges

The other "front-end" component of a phonograph is the cartridge or pickup which transforms minute vibrations into electrical signals for the amplifier system. If you suspect a dead or very weak cartridge, you can easily check its output by placing your finger first on the "hot" lead in the tone arm, and then on the needle shank. If the unit is defective, you'll notice a difference in noise output from the amplifier. A good test record and a sensitive scope or VTVM can spot other cartridge deficiencies.

As an aid in selecting a replacement, some original units are labeled as to manufacturer and model number. You also may be able to identify the cartridge by its physical design. This information can be useful when you are referring to a cross-reference guide covering several cartridge manufacturers. Such a pictorial guide and listing is shown in Fig. 6A. Part numbers can also be obtained from service data on the equipment using the cartridge. A replacement can then be found by using a guide like that pictured in Fig. 6B. In the reference guide of Fig. 6C, model numbers of various phono manufacturers are keyed directly to each replacement cartridge.

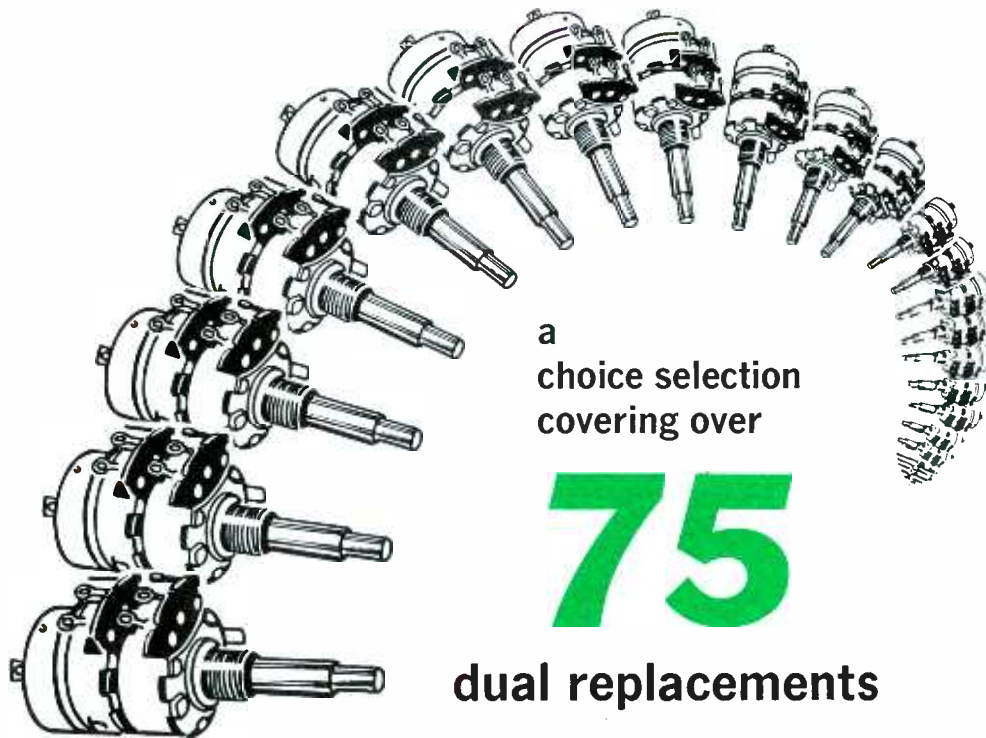

a
choice selection
covering over

75

dual replacements

right at your fingertips
for only \$19.75

NEW CLAROSTAT *Uni-TITE*

SERVICE CENTER

Right at your fingertips—ready for fast, easy, sure assembly in seconds—a choice of over 75 popular dual control replacements—in the new Clarostat Uni-Tite Service Center. Save those expensive trips for individual controls—have what you need on hand—finish the job and bill. That's the way to make money and you can do it with the Clarostat Uni-Tite Service Center. Ask your Clarostat distributor today!



SPECIAL INTRODUCTORY OFFER

At no extra cost, get this handy steel cabinet FREE with your Uni-Tite Service Center kit. This is a limited offer, so hurry and get yours! Only \$19.75 with Uni-Tite components to cover over 75 different dual television replacement controls!

EASIEST — BEST — UNI-TITE

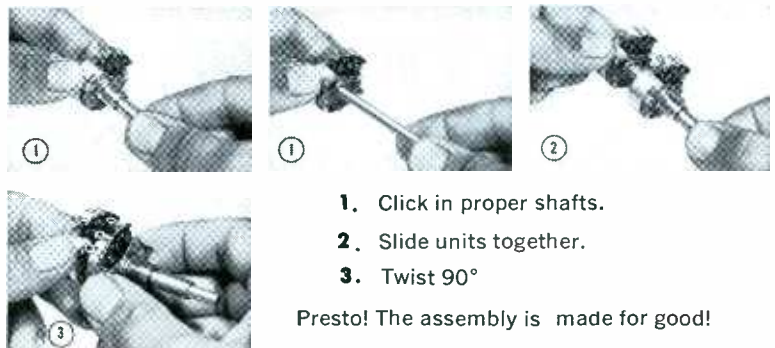

1. Click in proper shafts.
2. Slide units together.
3. Twist 90°

Presto! The assembly is made for good!

CLAROSTAT

CLAROSTAT MFG. CO., INC. DOVER, NEW HAMPSHIRE

Replacement kits containing only a few cartridges with universal mounting hardware are now available. The kits are made up so that each cartridge has a number of applications. Producers not featuring a full line of general or exact replacements are also making their new cartridges relatively small and with standard mounting provisions. Therefore, you may be able to offer your customer a replacement from a higher-quality line. When recommending a cartridge of this type, however, let the characteristics of the entire phono system dictate the

quality and price of the replacement. Don't "shoot the moon" if the system is only average; by the same token, be careful not to recommend an inferior cartridge for a good high-fidelity system.

For those engaged in phono repair work, a stock of popular cartridges not only saves frequent trips to the distributor's, but is also very convenient for substitution testing both in the customer's home and at the bench. However, since it is impractical for the average serviceman to maintain a complete line of phono cartridges, we suggest that

PHILCO CROSS REFERENCE GUIDE - SONOTONE DATA

SONOTONE MODEL	PHILCO MODEL	SONOTONE MODEL	PHILCO MODEL
100	100	100	100
101	101	101	101
102	102	102	102
103	103	103	103
104	104	104	104
105	105	105	105
106	106	106	106
107	107	107	107
108	108	108	108
109	109	109	109
110	110	110	110
111	111	111	111
112	112	112	112
113	113	113	113
114	114	114	114
115	115	115	115
116	116	116	116
117	117	117	117
118	118	118	118
119	119	119	119
120	120	120	120

(A) Sonotone data.

PHILCO CROSS REFERENCE GUIDE - PHILCO DATA

PHILCO MODEL	PHILCO MODEL	PHILCO MODEL	PHILCO MODEL
100	100	100	100
101	101	101	101
102	102	102	102
103	103	103	103
104	104	104	104
105	105	105	105
106	106	106	106
107	107	107	107
108	108	108	108
109	109	109	109
110	110	110	110
111	111	111	111
112	112	112	112
113	113	113	113
114	114	114	114
115	115	115	115
116	116	116	116
117	117	117	117
118	118	118	118
119	119	119	119
120	120	120	120

(B) Philco data.

CBS-RONETTE CROSS REFERENCE GUIDE - CBS-RONETTE DATA

CBS-RONETTE MODEL	CBS-RONETTE MODEL	CBS-RONETTE MODEL	CBS-RONETTE MODEL
100	100	100	100
101	101	101	101
102	102	102	102
103	103	103	103
104	104	104	104
105	105	105	105
106	106	106	106
107	107	107	107
108	108	108	108
109	109	109	109
110	110	110	110
111	111	111	111
112	112	112	112
113	113	113	113
114	114	114	114
115	115	115	115
116	116	116	116
117	117	117	117
118	118	118	118
119	119	119	119
120	120	120	120

(C) CBS-Ronette data.

Fig. 6. Original pickup is identified and replacement noted in these guides.

your replacement stock be governed by the phonos serviced in your particular area.

Replacement Hints

Aside from the differences in monophonic and stereo applications, one of the first considerations in choosing a replacement cartridge is its "physical fitness." Will the unit fit inside the tone arm? Is there clearance for a needle-selector knob? Do the mounting centers line up? Generally, the replacement should also be of the same basic type as the original—for example, ceramic or variable-reluctance — and the needle or needles should be suitable for playing records recommended for the phonograph. Weight of the replacement will also have a bearing on tracking force; therefore, differences here should be kept within reasonable bounds.

Just as important as physical aspects are electrical characteristics such as the frequency response and output voltage of the replacement. An original unit with a frequency range of from 50 to 18,000 cps

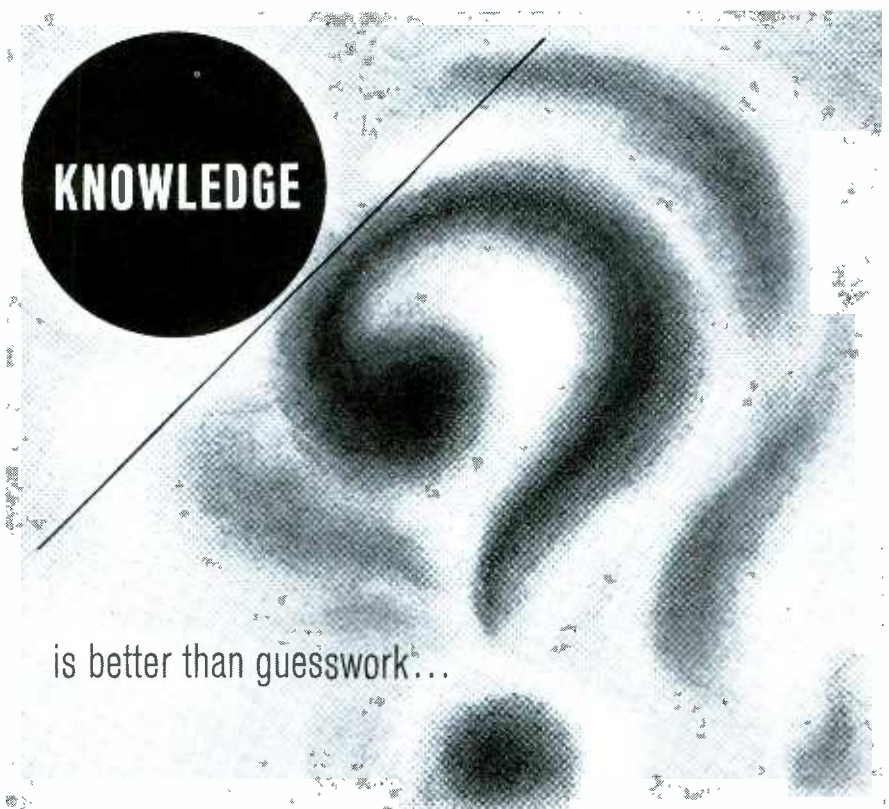

and STANCOR takes the guesswork out of TRANSFORMER REPLACEMENTS

When you use Stancor exact replacements, you *know* that you have a transformer that duplicates in every way the original manufacturer's electrical and physical specifications.

What's more, you know in advance that you'll be able to use a Stancor unit, because Stancor offers virtually complete coverage on flybacks and yokes . . . and the Stancor TV Guide, the most detailed in the industry, gives you exact information on the right transformer to use.

Contact your Stancor distributor for information on how to get your copy of the Stancor TV Guide.

Take all the guesswork out of transformer replacements—always specify Stancor.

STANCOR
ELECTRONICS, INC.

formerly Chicago Standard Transformer Corporation • 3501 West Addison Street • Chicago 18, Illinois

should not be replaced by a cartridge with a more limited response—say, from 75 to 7000 cps. If a change must be made, it's better to increase the response when possible.

The output voltage for most standard replacements can normally be classified as either high (2 to 5 volts) or low (below 1 volt). This, of course, does not apply to certain high-fidelity pickups designed to produce outputs in the millivolt range. About the only time you are apt to run into trouble with output voltage is when you attempt to replace an older high-output cartridge with one of the newer low-voltage types. The result will be a great reduction in over-all volume from the instrument and often more noticeable hum. This mismatch can sometimes be overcome, however, by changing the value of a series resistor or by bridging a coupling capacitor in the amplifier input circuit.

Some of your customers may inquire if their monophonic systems can be used to play stereo recordings. They can, but the lack of vertical compliance in the cartridge and the difference in needle size will soon ruin the records. If a customer wants to play stereo records on a mono system, or plans to convert to stereo in the near future, it would be wise to recommend a stereo replacement cartridge. Pro-

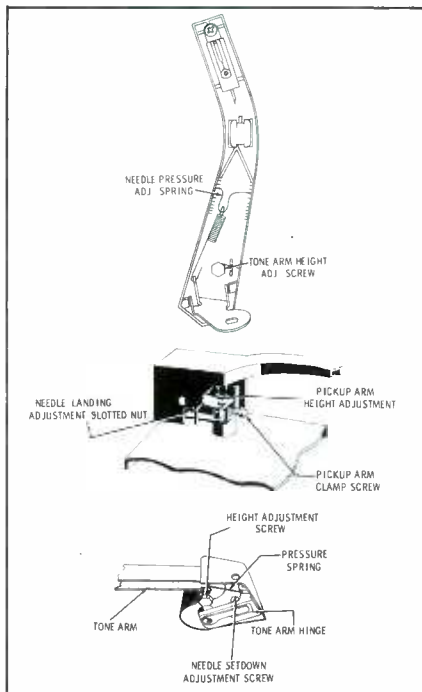

Fig. 7. Replacements are not complete until tone-arm adjustments are made.

vided you find a unit that has sufficient output and will mount properly, you can merely combine the two outputs to feed the single amplifier cable. While you're at it, you might wire the tone arm for future stereo operation by running a pair of shielded cables (one for each channel) back to the rear connectors. If the customer so desires, you might also install a switch at this point for selecting either a single- or dual-channel output from the cartridge.

Most of the cartridges you'll encounter will be held in the tone

arm by a spring clip or simple screw arrangement. Standard mounting centers for all units are either 1/2" or 7/16", and many in the replacement line will have provisions for both dimensions.

After you have installed any new cartridge, always check the tone arm adjustments—especially for tracking force. This can be accomplished by using a small gram scale and referring to recommended figures in the service data. Fig. 7 shows typical tone-arm adjustment points for several well-known phonographs. ▲

Eliminate the pitfalls of Universal Replacement Tuners

No drilling, filing or sawing required when you use...

CASTLE'S TV TUNER OVERHAUL

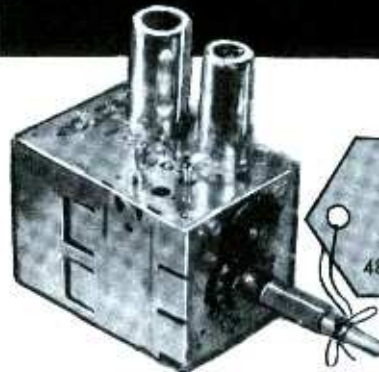

SAME DAY SERVICE!
on Popular Types
48 Hours most Others

ALL MAKES
ONE PRICE
\$9⁹⁵

VHF TUNERS
UHF TUNERS
UV Combinations *

*UV combination tuner must be of one piece construction. Separate UHF and VHF tuners with cord or gear drives must be dismantled and the defective unit only sent in.

Castle overhaul charge includes all labor and minor parts and written 90 day warranty. Tubes and major parts are extra at net prices. Tuner to be overhauled should be shipped complete; include tubes, shield cover and any damaged parts. Write down model number and state complaint. Pack well and insure.

NOW ALSO IN THE EAST

CASTLE
TV TUNER SERVICE, INC.

- 5710 N. WESTERN AVE., CHICAGO 45, ILLINOIS
- NEW! 653 PALISADE AVE., CLIFFSIDE PARK, NEW JERSEY
- IN CANADA: 136 MAIN ST., TORONTO 13, ONTARIO



Overhauling TV tuners is our only business. We do not manufacture and sell you a so called "universal" replacement tuner. When the original equipment tuner is overhauled by Castle you are assured that it will fit properly and the electrical specifications, set by the receiver manufacturer, will be met exactly.

Castle



Painless TV Alignment

(Continued from page 33)

plifier. For instance, a smeary picture can be produced by an increase in value of a video-amplifier load resistor, as well as by narrow IF bandpass. Picture ringing may be due to a defective video peaking coil rather than excessive IF bandpass.

The technician, like the layman, is readily deceived by the appearance of the picture. A sweep generator and scope give a far more positive indication of misalignment. However, if a quick check of band-

width is necessary, it is possible to obtain this information by viewing the composite video waveform at the plate of the video amplifier. A 7875-cps sweep rate is used, and the scope trace is expanded so that the corners of the horizontal sync pulse can be clearly seen. Rounding (Fig. 3A) indicates that the overall bandpass is too narrow, while ringing (Fig. 3B) results from excessive bandwidth. In most cases, correct alignment should provide the normal pattern of Fig. 3C.

There are several cautions to observe in making this test. First of

all, the scope must be a wide-band unit. In addition, the antenna used with the receiver must give flat response over the full bandpass of the received channel. (To check this point, try all channels available in the area.) Finally, the waveform of Fig. 3C can be expected only if the receiver has an over-all bandpass on the order of 3 mc or better. A number of sets, especially portables, are designed for fairly narrow-band operation; thus, they will normally round off the corners of the sync pulses. In some models, this effect is reduced by making up for narrow IF bandwidth with additional high-frequency peaking in the video amplifier. Thus any servicemen who tries to realign the IF for broader bandpass is likely to be stuck with a bad case of ringing.

Remember, the sync-pulse check is strictly a "quickie" test which becomes valuable only after a bit of experience.

Facts About IF Response

All TV sets have five IF-bandpass requirements in common, as demonstrated by Fig. 4. Point A, the picture-carrier frequency, should be set at approximately 50% of maximum amplitude. Point B, at the 50% level on the other side of the curve, should generally be more than 2.5 mc but less than 4 mc away from point A—depending on set design. (The difference between A and B is the "bandwidth" referred to elsewhere in this article.) The trace from point C to point D (0.75 mc either side of the picture-carrier frequency) should be a relatively straight line to insure accurate low-frequency reproduction. The top of the curve, between equal-amplitude points E and F, should be relatively flat; also, the shoulders should be well-rounded (except in a few receivers with very wide bandpass). Finally, the sound-carrier point G, 4.5 mc away from point A, should dip to a very low amplitude. Points A, B, and G are the most critical.

Three basic types of tuned circuits, which differ in both gain and frequency bandpass, are used for coupling between IF stages. The bifilar-wound transformer (Fig. 5A) is probably the most common. It has a relatively narrow bandwidth, tunes to a single peak with one core, and has a gain of unity.

NEW 3 IN 1 TRANSISTOR TESTER

GC
MODEL
36-560



MADE IN AMERICA
BY AMERICANS

all three transistor
tests in one unit...

TESTS: SHORTS-LEAKAGE-GAIN

only **19⁹⁵**



TEST PNP, NPN, POWER TRANSISTORS, DIODES AND RECTIFIERS with this High Styled but rugged, compact transistor tester. Only 5" x 5" x 1 1/2" in overall size and weighing only 1 1/2 pounds, this unit operates on two penlite batteries which under normal operating conditions last a lifetime. An ON-OFF switch eliminates possible meter or battery damage through accidental shorts. The body is finished in "Anti-Scratch" case with stylized chrome handle for easy carrying. The high visibility recessed panel is in a two-tone classic finish of pale gold and copper brown. Foreign equivalents listed in accompanying FREE MANUAL.

Write for our *FREE 400 page Catalog*

GC ELECTRONICS CO.

Division of Tectron Electronics, Inc.

Western Plant: 3225 Exposition Place, Los Angeles 18, Calif.
Main Plant: 400 S. Wyman St., Rockford, Ill., U.S.A.

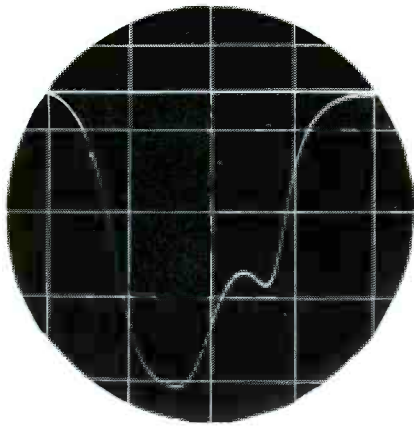

(A) With no fixed bias on IF.

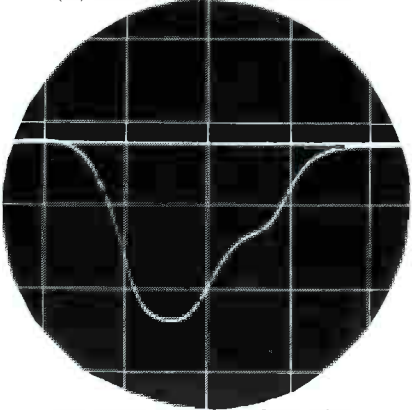

(B) With 3 volts of fixed bias.

Fig. 7. Curve involving simple AGC.

Fig. 5B shows an overcoupled, double-tuned transformer, which has a wider bandpass, provides some transformer gain, and tunes to a flat or double-peaked response. The series-tuned network in Fig. 5C includes two coils with capacitive, but not inductive, coupling. In addition to coupling capacitor C1, there is usually a length of coax connecting the coils; this introduces stray capacitance represented by the dotted-in capacitors on the schematic. Each coil is tuned separately to a frequency determined by its inductance and the total capacitance. This network is adaptable to a variety of response patterns — wide and flat, tilted, or fairly sharp. Usually, the gain is less than unity.

Most receivers use at least two of these circuits in the IF section, and some sets use all three types. When bifilar transformers are employed, they are usually peaked to certain frequencies, and the over-all bandpass is finally shaped with one of the other circuits. Variations of all three circuits are sometimes used to take care of special requirements for broadening or sharpening the response. The bifilar transformer itself is a variation of the tuned-

choke (inductive-capacitive coupling) network shown in Fig. 6.

Choosing an Alignment Method

The two most common sweep-alignment methods differ mainly in how the sweep signal is fed to the receiver. In the over-all technique, the sweep signal is at channel frequency, with markers at IF. The sweep is coupled to the receiver antenna through a matching network, and the markers are loosely coupled to some point in the IF strip. This method has the advantage of convenience in injecting the sweep

signal, but it also has a few drawbacks. For one thing, you cannot be sure of accurate results unless the RF response of the tuner is correct. The fine tuning must also be very accurately adjusted, so that the local oscillator is operating on the correct frequency. Furthermore, not all sweep generators provide the separate marker output required for this method.

The alternate technique, wherein the sweep signal is capacitively coupled into the mixer by way of a floating shield or insulated metal strip, has the disadvantage of being

TIPS

for the
**ELECTRONIC
TECHNICIAN**

Now! The TV-Radio-Audio Replacement of the Future!

THE MARK VII[®] SILICON RECTIFIER

replaces all existing types.

750 mil minimum
50 amp surge

*type no. 5A4-95

ACTUAL SIZE

NOW! FROM SPACE AGE TECHNOLOGY. An important development brings you a single rectifier that replaces all other rectifier types. This development is as significant as the introduction 4 years ago of silicon rectifiers, which have come to be almost universally used in TV-Radio-Audio circuits.

NOW! HIGHER RATING—SMALLER SIZE. The IR "Mark VII" is rated at 750 mil minimum and has a surge capacity of 50 amps. Looks like and is no larger than a half watt resistor. Insulated, completely safe; can't short to chassis.

NOW! CARRY ONLY 1 RECTIFIER. For every replacement, the Mark VII fits anywhere selenium or silicon rectifiers were originally used. Long lasting, easy to solder due to pure silver leads, fully guaranteed. Sets a new break-through in reliability, and in price.

**SPECIAL INTRODUCTORY
"MONEY BACK GUARANTEE!"**

2 FREE
RECTIFIERS
with purchase
of 5 Pack
ONLY \$5.60

Buy 5 Mark VII Rectifiers — get 2 free! Use the 2, and if they do not meet all the specifications that we state, return the 5 and receive the full purchase price.

INTERNATIONAL RECTIFIER

233 KANSAS STREET • EL SEGUNDO, CALIFORNIA



DEFINES IT AS.....

***A MARK OF EXCELLENCE!**

THE WORD *Merit* OF COURSE!

Located as we are in Southern Florida, Merit is host to a steady stream of visitors interested in seeing what makes a modern transformer plant 'tick'.



They never fail to be impressed with the 100% testing procedure under actual working conditions to which all Merit units are subjected.



Just one more reason why Merit products are truly products of excellence.



MERIT PLAZA - HOLLYWOOD, FLORIDA

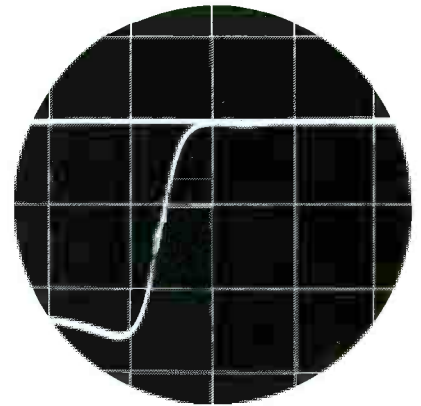

(A) 43.25-mc marker on curve slope.

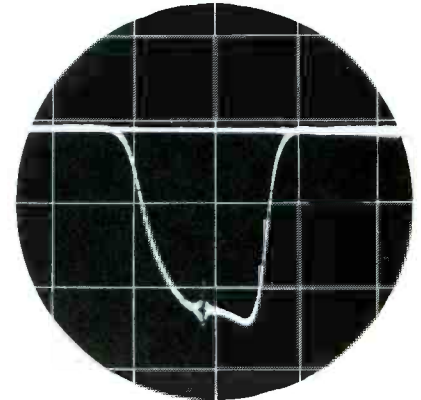

(B) Curve should look like this.

Fig. 8. Major frequency error.

subject to distortion caused by the local oscillator on certain tuner settings. However, this disadvantage is easily overcome by disabling the oscillator (more about this later) or by selecting a channel where the bandpass curve is obviously not being affected by the oscillator. On checking all channels, you will usually find that a fair proportion of them are undisturbed by oscillator operation. An important advantage of this alignment method is that it can be used with virtually all sweep generators and scopes in general use. The marker generator does not have to be a separate piece of equipment, but can be an integral part of the sweep generator.

Alignment Bugbears

Certain annoying effects crop up in practically every alignment setup. Two of the most common problems are spurious beats (pips) produced by the local-oscillator signal, and hash on the response curve caused by radiated horizontal pulses. The oscillator interference can be removed by wrapping a strand of fine wire from the grid pin to the cathode pin of the oscillator tube. Hash due to radiated horizontal pulses is merely a nuisance, and it

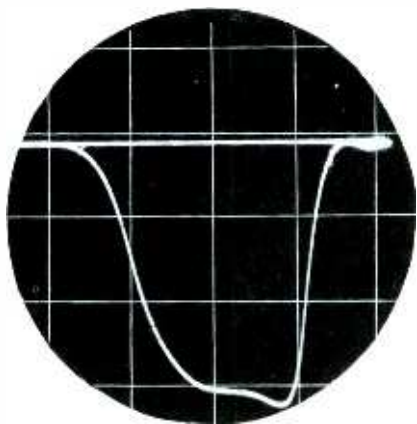

(A) Find trap frequency with marker.

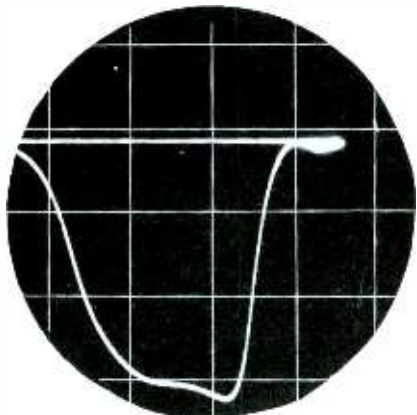

(B) Cover with scale line; then dip.
Fig. 9. Using scale to tune traps.

often can be ignored unless it is strong enough to compete with the markers. In this case, you can minimize it by keeping the "hot" scope lead to the video detector as short as possible, in addition to connecting a 500- to 1000-mmf capacitor across the vertical terminals of the scope to bypass the pulses. Another way to get around the problem is to kill the horizontal oscillator momentarily while checking marker points. There are other means of eliminating the hash, such as disabling the horizontal output stage, but these measures are not often necessary.

How to Simplify Alignment

Any trick that reduces the amount of equipment used in alignment will make the process that much easier.

Skip the Fixed Bias

In checking the alignment of a receiver that uses the voltage developed across the video-detector load as AGC bias, you can check the alignment without using a bias box — if you keep the sweep-generator output at a very low level. Here's proof: Fig. 7A is the band-pass curve of a receiver of this type, obtained without using fixed bias.

NOW... Master System Performance at a Home Booster Price!

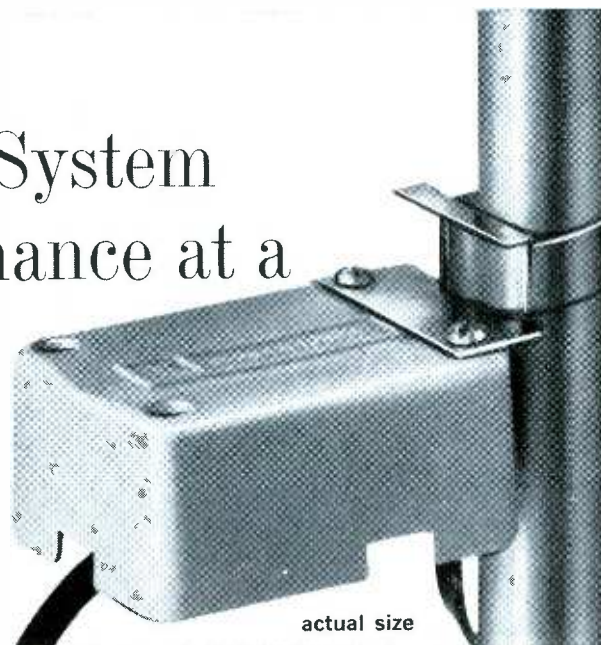

Blonder-Tongue signal master, AB-4

(new transistor, mast-mounted TV/FM 4-set booster)... \$29.95 list

- ✓ Transistor circuit provides lowest noise, maintenance free operation—no tubes to burn out or replace—no heat dissipation problems.
- ✓ Mast mounting takes advantage of best signal-to-noise ratio—minimizes snow. (Can also be mounted at any convenient point along the download.)
- ✓ World's smallest and lightest booster—no additional weight or wind resistance for mast to bear.
- ✓ Remote power supply at set uses 4 low-cost flashlight batteries for pure d.c.—eliminates AC power line, and components which may fail.
- ✓ Converts existing antenna into a powerful amplifier-distribution system—no need to invest in a new antenna.
- ✓ Eliminates costly installation of giant antenna arrays in most fringe areas.
- ✓ Provides improved FM reception (gain 12-15 db).
- ✓ Stripless 300-ohm terminals on booster and remote power supply for fast installation, positive contact.

✓ No separate balun needed—matches impedance of antennas and TV sets.

ALL THIS PLUS . . . 4 set coupler incorporated in remote control power supply distributes fully isolated amplified signals for brilliant reception on up to 4 TV or FM sets.

Improve TV and FM reception today. Add the new Blonder-Tongue AB-4. Sold thru distributors. For details write. Dept. PF-10.



<p>1 set gain: up to 19 db, channel 2 Up to 10.5 db, channel 13</p>	<p>2 sets gain: up to 14 db, channel 2 Up to 6 db, channel 13</p>	<p>3 sets gain: up to 13 db, channel 2 Up to 4 db, channel 13</p>	<p>4 sets gain: up to 10.5 db, channel 2 Up to 2 db, channel 13</p>
--	--	--	--

Patent applied for

engineered and manufactured by

BLONDER TONGUE

9 Alling St., Newark, N. J.

Canadian Div.: Benco Television Assoc., Toronto, Ont. Export: Morhan Export Corp., N. Y. 13, N. Y.
 home TV accessories • UHF converters • master TV systems • closed circuit TV systems

NEW PRICE NEW DESIGN CLASSROOM TV STAND

Custom designed to be wheeled over auditorium seats, also ideal for hospitals, institutions, and closed circuit applications.



PAT. PENDING

- Bronze baked finish
- Wide 7/8" rubber wheels—will not mar floors.
- Large 28" x 30" base assures non-tipping.
- Large 4" ball bearing casters.
- 5° Angle on TV shelf for "No Glare" viewing.
- Scientifically designed—exceeds Federal and MPATI specifications.
- Heavy 1" OD steel tube construction makes the most sturdy, rigid, stand on the market.
- ALL joints welded

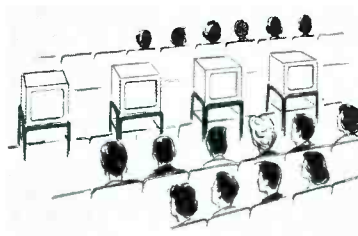

Tested and approved in over 1500 classrooms and auditoriums



Dealer Net Approx. \$29.50 (f.o.b. factory) depending on area.

Complete Information and Mailing Pieces Available Also Distributor Prices—Write or Phone Today

VIRGINIA Corp.,

1800 W. Virginia St., Evansville 7, Indiana
Phone MA. 3-6489

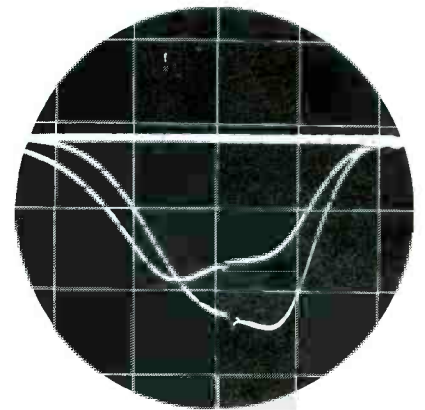

Fig. 10. Low and high curves—seen before and after peaking one adjustment.

Applying 3 volts of AGC-override bias to the same receiver resulted in the curve of Fig. 7B. Both waveforms display a tilted bandpass which reveals the need for alignment. In addition, both curves have less than normal amplitude at the picture-carrier frequency (note the barely perceptible marker on the left skirt), further indicating the need for realignment.

When no fixed bias is applied to the AGC line, it is important that the signal at the video detector be kept low enough to avoid peak-flattening in the curve or a tendency toward IF oscillation. The best precaution is to set the scope sensitivity so that 2 volts equal 2" of deflection (on a 5" scope), and then keep the sweep-generator output low enough to avoid exceeding this waveform height.

Check for Proper IF Range

As soon as you have set up the alignment equipment and obtained a rough curve, tune the marker generator to approximately 1 or 2 mc below the picture-IF frequency, and make a quick frequency-range check. If the marker falls on top of the curve, you can proceed with alignment. If it does not, the curve may be a spurious beat signal, or the local oscillator may be incorrectly tuned for an over-all RF-IF check; on the other hand, regeneration or gross mistuning in the IF strip may be indicated. Fig. 8A shows an odd result of this check on a set that seemed badly in need of alignment. The marker is at 43.25 mc. My doubts that mere misalignment could cause such a severe frequency shift were confirmed when, on further examination, I discovered that someone had replaced the

NEXT MONTH — COLOR!!! The Entire Issue

What's New in Color TV?

Color Servicing in the Home

Test Equipment for Color TV

Isolating Chroma Troubles by Symptoms

Setting Up the Chroma Circuit

Case Histories of Color TV Troubles

8-Page Bonus

Color TV Circuits

... and how

they work.

Plus... many more servicing features

Enter my subscription to PF REPORTER and send me free book(s) checked.

3 Years \$9.00 2 Years \$7.00 1 Year \$4.00

The Troubleshooter's Handbook
 Servicing Industrial Electronics
 Servicing TV from Tuner to Picture Tube

Check one for each year you subscribe

Bill Me

Remittance Enclosed

Extend Present Subscription

Take this coupon to your distributor, or mail to:

Howard W. Sams & Co., Inc.

2201 E. 46th St., Indianapolis 6, Ind.

Name _____

Firm _____

Address _____

City _____ Zone _____ State _____

Please Check Your Business Classification

- | | |
|---|---------------------------------------|
| <input type="checkbox"/> Independent Radio, TV Serviceman | <input type="checkbox"/> Owner, Mgr. |
| <input type="checkbox"/> Retailer with Service Department | <input type="checkbox"/> Service Mgr. |
| <input type="checkbox"/> Industrial Electronics Service | <input type="checkbox"/> Employee |
| <input type="checkbox"/> Other (Specify occupation and title) | |

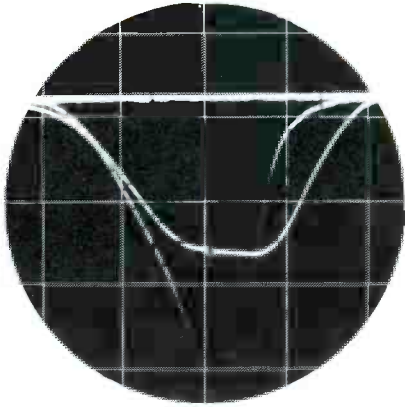

Fig. 11. VTVM alignment might not reveal enormous peak in middle of curve.*

12AU7 video detector with its industrial equivalent, a 5814. Installing a new 12AU7 shifted the band-pass back to the normal range, as shown in Fig. 8B.

Use Scope Scale to Tune Traps

Much has been written about techniques for viewing markers in trap notches. Removing the bias box, expanding the trace horizontally or vertically, and increasing the sweep signal are among the suggestions that have been advanced. By and large, these tricks are a waste of time. A trap notch can actually be adjusted with the marker turned off. Here's how: Before removing the marker, first set it to the trap frequency and detune the trap so that the marker rides up into view (Fig. 9A). Next, using the horizontal centering adjustment of the scope, shift the entire waveform until the marker coincides with a vertical scale line on the scope face. Then, turn the marker generator off, if you like (it isn't necessary to



(A) Size comparison with match.



(B) Wand being used to check tuning.
Fig. 12. Tuning wands for alignment.

KEEP A CONSTANT CHECK ON YOUR LINE VOLTAGE

with the New RCA WV-120A
POWER LINE MONITOR

- **EXPANDED SCALE***
Scale is expanded from 100 to 140 volts for easy reading
- **HIGH ACCURACY**
±2% at 120 volts; ±3% at 100 and 140 volts
- **TRUE RMS READINGS**
Moving-vane type meter gives accurate RMS readings, even when line voltage is not pure sine wave
- **FAST METER ACTION**
Reveals "bounces" and fluctuations in line voltage
- **LARGE NUMERALS, LARGE POINTER, LARGE SCALE**
Provide easy readability from distance of ten feet or more
- **CONVENIENT WALL MOUNTING**
Holes are provided in rear of case for wall mounting
- **LOW PRICE—ONLY \$14.95***
Extremely low priced for a large-sized, expanded scale, RMS meter of such high accuracy

See the RCA WV-120A at your Authorized RCA Distributor.
*Usert Price (Optional)

Electron Tube Div., Harrison, N. J.



The Most Trusted Name
in Electronics



Introducing the perfect mate for any TV/FM antenna

NEW TRANSISTOR

JERROLD® POWERMATE

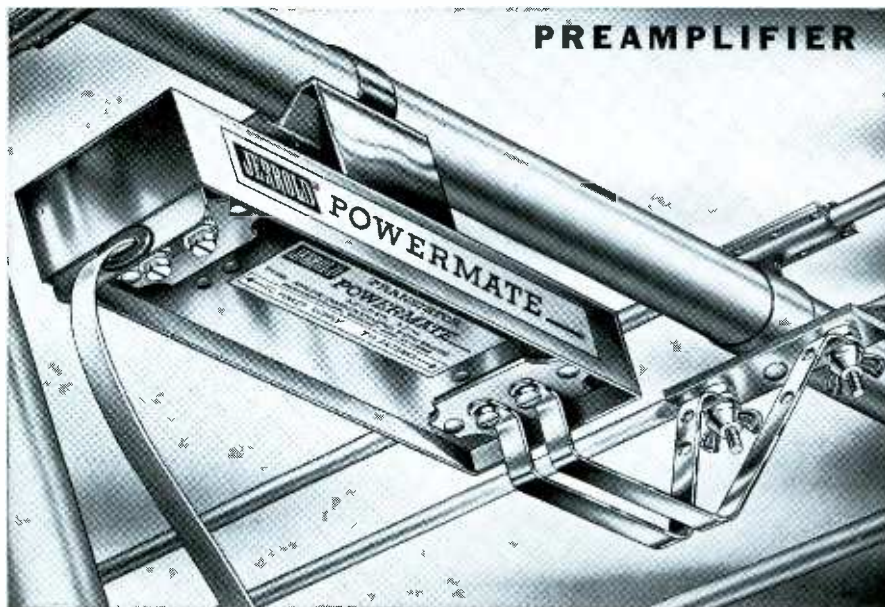

mounts on boom, mast, wall, window... offers highest gain, lowest noise figure

Here's the preamplifier for every TV antenna in your area, whether new or up for years! The exclusive universal bracket of the new JERROLD Transistor POWERMATE permits mounting directly on the antenna boom (for greatest boost before download losses) or at *any* other point—along the mast, on the wall or windowsill, behind the set—anywhere your best judgment dictates.

And look at this gain: An average of 13.9db at Channel 13 and 18.25db at Channel 2—by far the highest in the business! This remarkable gain gives any antenna system the lowest System Noise Figure obtainable—the key to better pictures.

See your distributor today, or write for special bulletin describing System Noise Figure.

Only \$39.95 list, complete with power supply

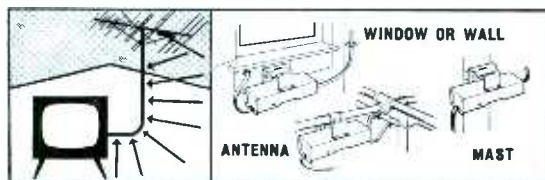

MOUNT IT AND FORGET IT

On the antenna or anywhere along the download, POWERMATE is up for good. Same 300-ohm lead that carries signal also carries 15 volts ac to POWERMATE. No tubes, no batteries to replace.



REMOTE A-C POWER SUPPLY

installs on or near receiver, draws less current than an electric clock. No polarity nuisance when attaching to lead, no danger of damaging the transistor.

JERROLD® ELECTRONICS CORPORATION
Distributor Sales Division, Dept. IDS-184
The Jerrold Building, Philadelphia 32, Pa.

Jerrold Electronics (Canada) Ltd., Toronto, Ontario
Export Representative: CBS International, New York 22, N.Y.

AMERICA'S LEADING MANUFACTURER OF TV-FM RECEPTION AIDS AND MASTER-ANTENNA-SYSTEM PRODUCTS.

do so), and tune the trap so that the curve dips at this line as shown in Fig. 9B.

Dispense With the VTVM

Many alignment instructions specify using a VTVM for adjusting coils or transformers which are peaked at one definite frequency. Why not use the scope instead, since you'll eventually have to hook it up anyway for the final response check? With the sweep generator and scope set up as usual, place the marker at the resonant frequency of each coil in turn, and tune the slug for maximum amplitude of the waveform at the marker. At first, you will probably find it a little hard to ignore other portions of the waveform which may be rising faster than the marker, but you can soon train yourself to concentrate on the one point you are interested in at the moment. Fig. 10 shows how the curve is likely to shift, as well as grow in amplitude, when one slug is turned.

The scope method of pre-peaking has many advantages over the use of a VTVM. As the various stages are aligned, the over-all bandpass begins to take on its ultimate shape before your eyes. In addition, the scope catches faults in the curve (such as the extremely high peak in Fig. 11) which could conceivably be missed if a VTVM were used.

Use Tuning Wands

To aid in final shaping of bandpass curves, I use the home-made tuning wands shown in Fig. 12. These units, smaller than any I have seen commercially available, were made out of small powdered-iron cores (from old radio IF transformers) and 1/8" brass slugs, fastened on 1/16" nylon rods.

If the bandpass of a video IF section does not look quite right on the final response check, I dip each end of the wand into various coils while watching the scope for improvement. If a coil responds well to insertion of the powdered-iron tip, I tune its slug farther into the coil form; on the other hand, an improvement obtained with the brass tip tells me to back off the slug. In this way, I almost effortlessly prove to my satisfaction that I've done the best possible alignment job. ▲

TV Intermittents

(Continued from page 26)

to be just a bit of a ham actor. It does!

If you happen to have a loaner TV, this might be the place to use it—especially for one of your better customers, or one who puts up a fuss at losing use of the set for a few days. Tell the customer, "We may have trouble getting the thing to act up at the shop, and we don't want you to miss Gunsmoke!" Besides keeping him pacified, this is a dandy way to sell second sets or new portable TVs, if you're also a dealer.

Investigation

The second I is Investigation. You might as well go ahead and pull the chassis; you'll have to, anyhow, in 90% of all intermittent troubles. When you get it out of the cabinet, go over it very thoroughly, looking for burned resistors, loose solder joints, and anything that could cause the trouble. A careful physical examination has cured many an intermittent.

Information

The last I is Information. Before you do anything else, get out the service data on the set, and look it over closely—paying particular attention to the stages where the trouble seems to be located. Don't overlook a component in another circuit which, because of interlocking action or connections through power supplies, could be at the root of the trouble. For instance, one well-known chassis has a typical intermittent AGC trouble which is caused by an open grid resistor in the audio stage. The defect fouls up the 150-volt line, since the audio tube is part of a stacked B+ circuit. This, in turn, affects the screen voltage on the AGC keyer.

Another good idea is to clip an extra sheet of paper to the service-data folder for making notes on intermittent symptoms and their causes. Such troubles often become chronic, and show up in almost all of a particular run of sets.

Types of Intermittents

There are two basic species of intermittents—the "jar" type, where the trouble can be made to show up by hitting the cabinet or

11 down-to-earth ways to sell high-profit sound:

Sonotone ceramic and crystal cartridges

One line of cartridges to meet virtually every service or replacement need, at a price that allows you excellent profits... that's what Sonotone offers you today. There are Sonotone ceramic cartridges for any sound system... and equalizers to convert any magnetic input for ceramic cartridge use. 70 phonograph manufacturers use Sonotone as original equipment. And more than 12,000,000 satisfied users make up a "pre-sold" market for your future service or sales profits. For full profit opportunity, stock the full Sonotone Cartridge line!

Stereo:

Velocitone Assembly DeLuxe "9T" cartridge plus matched equalizers for improved sound through any magnetic input system. Response: Flat $\pm 1/2$ db from 20 to 6,000 cps, 1 db to 17,000 cps with deliberate rolloff to 20,000 cps.

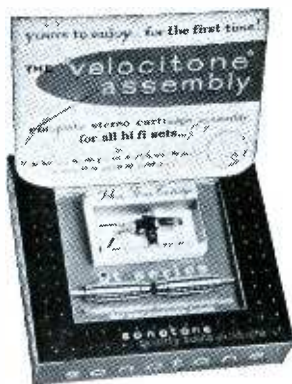

"9T"—Superb quality for even the most advanced audiophile. Response: Flat ± 1 db from 20 to 17,000 cps, with deliberate rolloff to 20,000 cps.



"10T"—A budget-priced ceramic cartridge for inexpensive phonographs. Response: Flat from 20 to 15,000 cps ± 2.5 db.



"12T"—Crystal cartridge offering clear stereo sound at budget price. Response: Flat ± 2.0 db to 10,000 cps, smooth rolloff to 15,000 cps.

"T1" Tonearm assembly complete with "12T" stereo cartridge for the best possible sound anywhere near the price.

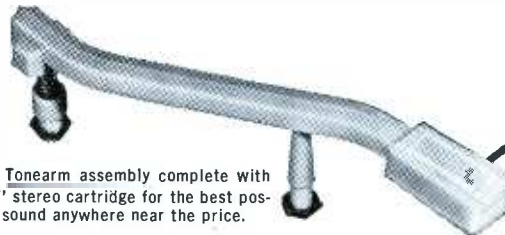

"8TA"—Fine economical replacement to achieve well-balanced reproduction from most popular systems.

Response: Flat ± 2.5 db from 20 to 15,000 cps, with gradual rolloff to 20,000 cps.



"16T"—Ideal cartridges combining top quality with moderate price... now original equipment on most leading phonographs.

Response: Flat ± 1 db from 20 to 10,000 cps, with smooth rolloff to 12,000 cps.

"18T"—Companion to the 16T with slightly greater output voltage, moderately priced and now original equipment with most phonograph manufacturers.

Response: Flat ± 1 db from 20 to 10,000 cps, with smooth rolloff to 12,000 cps.



"2T"—Wide spectrum response... Ideal for monophonic replacement at less cost. Response: smooth 20 to 20,000 cps, flat to 12,000 with gradual rolloff beyond.

Monaural:

"1P"—Improves performance of even simplest record players.

Response: smooth 20 to 20,000 cps, flat to 12,000 with gradual rolloff beyond.

"3T"—Crisp, clear highs... full authoritative lows. Outperforms expensive magnetic cartridges.

Response: smooth 20 to 20,000 cps, flat to 15,000 with gradual rolloff beyond.



Sonotone

ELECTRONIC APPLICATIONS DIVISION.
Dept. C10-101, Elmsford, N.Y.
In Canada, contact Atlas Radio Corp., Ltd., Toronto

Leading Makers of Cartridges • Speakers • Tape Heads • Mikes • Electronic Tubes • Batteries

chassis, and the "electrical," where jarring does no good at all. Most of the latter type are more accurately called "thermal" (caused by heat), but "electrical" is one of those mistomers which seems to have stuck.

"Jar" Intermittents

Let's take the easier type first. If the set produces the trouble when jarred, there is definitely a "loose connection" somewhere, and "it shouldn't be too hard to find." Quotes here are from the customer, not the technician! The first rule

for working with a problem of this type is another old Chinese proverb: "Softly, softly, catchee monkey." In other words, put down that sledge hammer! Much as it relieves your bad disposition to bang on the set as hard as you can, this won't help you find the trouble. After making a tentative diagnosis of where the trouble is, *gently* tap each part around that stage with the eraser on a common pencil, an insulated tuning tool, or something similar, meanwhile listening for noise or watching for flashes on the screen. A soldering-aid tool

with a pointed, split end is very handy for moving, pulling and twisting component leads. Check for loose solder points, blobs of solder hanging down under terminal boards close to the chassis, and cracked wiring on PC boards.

Tube sockets, especially the wafer type, are happy hunting grounds for this kind of trouble. If you find loose pin contacts, take the tube out, and spring the contacts back together to restore a firm grip. A squirt of spray cleaner into tube sockets is also a good idea.

PC-board intermittents can sometimes be pinned down by tacking a jumper of hook-up wire between two points (Fig. 1). If this stops the noise, leave it there! (Modify it as necessary to make a professional repair, of course.) Caution: If you have *one* trouble like this, there may be more, so if a jumper doesn't cure the trouble right away, leave it in place and try another. You may find two or three bad conductors. Use light, solid, plastic-insulated wire, in pieces as short as possible, and be sure they are well soldered into place.

Thermal Intermittents

These are real headaches! The basis of this trouble lies in thermal expansion of capacitors, resistors, PC boards, terminal strips, or even the whole chassis, putting a strain on components or connections. Usually, the set will play normally for hours with the chassis out on the bench; without the heat-trap effect of the cabinet, the temperature never goes high enough to trigger the trouble. Thus, you may have to apply extra heat. Cover the chassis with several thicknesses of cloth or a cardboard box (leaving a hole so that you can see the screen, if you have picture trouble), and let it cook.

You can apply localized heat by fastening a piece of aluminum foil over the end of a standard heat lamp, with a 1" circle cut out of the middle (Fig. 2). This will let you heat suspected areas without burning up other parts. An old gooseneck desk lamp is very handy for this purpose. If you're lucky enough to have pinned the trouble down to a single stage, you can also heat individual parts by holding the tip of your soldering iron close



EXACT REPLACEMENT INDOOR TV ANTENNAS

- ✦ Pre-priced for full profit markup
- ✦ Skin packed for identification and protection
- ✦ 72 models covering 22 TV makes
- ✦ Color coded by set manufacturer
- ✦ Same as original equipment
- ✦ From GC-Radion, the pioneer in indoor TV antennas

Radion exact replacement indoor antennas let you cash in on big profit potential. Each package is cross referenced to manufacturer's Part Numbers, and contains fresh, new equipment.

Your GC-Radion Distributor has full information. Ask him for a copy of the free 24-page "Indoor Replacement Antenna Cross Reference Guide," or write us.



GC ELECTRONICS COMPANY

a division of Textron Electronics, Inc.

400 S. WYMAN ST., ROCKFORD, ILLINOIS

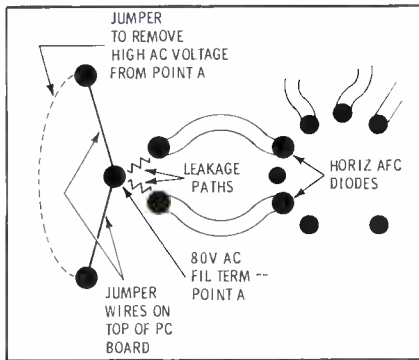

Fig. 3. Horizontal sync trouble was due to leakage across a damp PC board.

to them, and watch or listen for the trouble to show up.

Just the opposite procedure — artificial cooling — can also help you deal with thermal troubles. If the set acts up when first turned on, but plays perfectly after a brief period (say ten minutes) of operation, you can waste a lot of time waiting for the thing to cool down after each test. One easy way to speed up cooling is to spray the suspected component or area of the chassis with one of the chilling chemicals, sold in aerosol cans under various trade names.

You can also put the set in front of the cold-air outlet of your air conditioner, or direct a fan on it. One exasperated technician put a whole TV set in his home freezer to locate a “cold” intermittent. He found it, too!

Any kind of equipment in metal cabinets can have peculiar troubles. A classic case of this type was noted in an old PA system. It worked perfectly for about a half hour, and then went completely dead. There were no burned parts or bad tubes, and the unit played for hours on the bench. After some time, I discovered that when the amplifier was reassembled, the center lug on the master gain control was very close to the metal cabinet. You guessed it; after the amplifier had been operating long enough for the chassis to heat up, thermal expansion caused the input to short to ground.

Another common thermal trouble shows up on large tubes — 5U4, 6BG6, 6AX4, and so on. These tubes run so hot that the solder in the base pins sometimes crystallizes. Picture tubes also seem prone to develop the same defect. Thermal expansion and contraction can make a beautiful intermittent out of this condition! Such cases are

Quality you can count on EVERY SINGLE TIME!



AEROVOX MICA CAPACITORS

“Trouble-free” best sums up the many advantages in using top-quality Aerovox mica capacitors. Quality isn’t a matter of chance — it’s a result of engineering and manufacturing know-how gained from years of experience in producing the industry’s leading line of capacitors for both initial equipment and replacements.

The superior quality of Aerovox mica capacitors is your best protection against the costliness and inconvenience of premature failures. Yes, it’s good to know you can service a set and forget about call-backs.



POSTAGE STAMP MICAS... for all those applications where only the smallest axial leads will do. Perfect for critical applications such as horizontal or vertical oscillators. All units are color-coded and stamped with capacity value.



HIGH VOLTAGE MICAS... designed especially for TV and low power transmitters and power amplifier applications. These top-quality units feature the highest voltages available in these can sizes. Every unit is marked with capacity and working voltage, and tested at double the rated voltage to insure dependable service and long life.



Plastic-Coated DIPPED MICAS... superior in many instances to conventional molded units. High operating temperatures, excellent long-life characteristics, ideal for printed-circuit assemblies. Smaller physical sizes with unsurpassed performance and stability features.

AEROVOX mica capacitors are available in a complete range of capacitance values. Your local Aerovox Distributor is your one-step source of supply—call on him for all your capacitor needs. Remember—it pays to use Aerovox!

AEROVOX CORPORATION

DISTRIBUTOR DIVISION

NEW BEDFORD, MASSACHUSETTS

Picture-Tube Repair Tool

Eliminates that hard soldering job

only \$1.25 each

PT-1
3/32" PIN

Fix loose pin connections in seconds. Pays for itself in time saved on first job. 3" long.

Patented

Intermittent operation of picture tubes due to defective solder connections easily corrected. Provides solid electrical connections, can also be used as channel-selector wrench and screwdriver. Pin keeps its original form. A 3-in-1 tool.

3 MODELS ELIMINATE SOLDERING

Makes Solid Electrical Connections

Phono-Plug Crimper

Slip wire in "pin plug," insert in tool, and squeeze job is done.

AU-2
1/8" PIN

C-rings 1c ea.

Use end of tool to push on C-ring for ground connection.

Ant. plugs, hi-fi, multiple plugs, public address, radio and TV tubes, radar, speakers, and loop connections. Many, many more uses.

Model LC-3 for 5/32" pin diameter

At your parts distributor or write us

BERNS Mfg. Co.
9853 Chalmers,
Detroit 13, Mich

Service Dealer Ad Program— No. 10 in a Series

TV NEUROBIS
PUGNACITY
NO HOCUS FOCUS
THIRD WOOVERS?

TV REPAIR
YOUR NAME
ADDRESS

YOUR NAME
YOUR ADDRESS

YOUR NAME
YOUR ADDRESS

YOUR NAME
YOUR ADDRESS

PF REPORTER
2201 E. 46th Street
Indianapolis 6, Indiana

Please send me:

- ad mats @ \$1.75
- glossy prints @ \$1.00
- both for \$2.50
- Entire series of 60 mats, plus bound glossy proof book @ \$25.00.

Enclosed is \$_____ to cover cost.

Name _____

Address _____

City _____ Zone _____ State _____

1061

always immediately apparent on visual inspection; the offending pin looks gray and crumbly instead of having the smooth, shiny appearance of a good solder joint. Resolder or crimp the pin.

Time Constants

You can get many clues from knowing the length of time that elapses before the trouble appears. By all means, ask the customer about this; but you'd better check his estimate by timing the set with a watch. Customers have a bad habit of exaggerating about time! One lady insisted her TV set "took 15 minutes to light up." Timed, it came on in two minutes and 40 seconds.

Different defects display different time constants, generally (but not invariably) following this rough rule of thumb:

1-2 minutes, tubes. A tube reaches operating temperature in a matter of seconds, but it takes about two minutes for the whole structure to warm up to the point where thermal expansion can cause interelement shorts, opens, and comparable troubles.

2-5 minutes, leaky capacitors. If a capacitor has slight leakage, made worse by heating, it usually falls within this time limit. On the other hand, purely "physical" trouble, in which thermal expansion of the chassis pulls the capacitor open, generally takes longer to appear.

5-15 minutes, resistors. This means the "drifters" — resistors which change value when heated. The trouble often isn't due to current flowing through the resistor itself, but to heat from a nearby component such as a large dropping resistor.

The time constant of an open

capacitor is almost the same as that of a resistance drift, but the two troubles can be distinguished from each other by the characteristics of the "cut-out." An opening capacitor will cause the symptom to appear suddenly, while a drifting resistor will cause a very gradual change in operation.

Electrolytic Capacitors

Electrolytics are responsible for some of the most puzzling intermittents — bending, weaving, loss of vertical sync, etc. A loss of filtering efficiency allows unwanted pulses, hum, and hash to get into places where they can cause trouble.

An electrolytic capacitor is made of rolled-up aluminum-foil plates, separated by a porous material saturated with electrolyte. The connections to the plates are made through small aluminum tabs which are usually spot-welded to the foil. If this joint becomes loose through electrolytic action, the capacitor becomes intermittent. Heavy surges of current, such as would be caused by shunting a new capacitor across the old one with the power on, will sometimes cause the defective connection to weld back together. This "heals" the capacitor, and the trouble disappears.

One valuable tool for hunting bad electrolytics is a capacitor-substitution box. These units typically have a resistor in series with the test capacitors so they will charge only slowly when connected across the suspected part. This eliminates the sudden surge which might cause healing of the old electrolytic.

The best way to use one of these devices is to hang the low-capacitance probe of a scope on the B+ line in the vicinity of the stage

MERCURY TV TUNER SERVICE

890-1 River Ave., Bronx 51, N.Y.
"Largest in the East"

VHF-UHF TUNERS

7 Months Warranty

Price Includes Labor & Minor Parts

TUBES & MAJOR PARTS AT NET PRICES

When Shipping Tuner: Include Tubes, Shields and Damaged Parts.

Give Model Number and State Complaint

PACK WELL AND INSURE
24 HOURS ON POPULAR TYPES

ALL MAKES ONE PRICE!

\$9.50

where the trouble seems to be. If you can see more than just a trace of hum, hash or pulses on the B+ line, begin shunting electrolytics in that branch of the power supply. When you hit the right one, the scope pattern will drop to a straight line and the trouble will go away.

Diagnosis

In my opinion, 99% of the "knack" for successfully servicing intermittents is a matter of correctly diagnosing the problem. The only way to cope with intermittents (outside of sheer luck, which is also useful) is to sit down and make a cold, calm, *logical* analysis of the symptoms, and from these, make a *tentative* diagnosis. Notice the emphasis on "tentative." Being in a hurry to form a definite opinion slows up the job more than anything else you can do. If you begin work with an idea solidly implanted in your head that the trouble has "got to be" in a certain stage or part, you'll be completely incapable of making an intelligent diagnosis. You will often actually overlook symptoms that point toward another stage or part, because they don't fit in with your preconceived notion of where the trouble will be found. Therefore, the most valuable asset you can have in this type of work is a *completely* open mind! Always be ready to discard your original theory entirely and substitute another one, if the evidence is against your first idea.

Let's Get Down to Cases

Here are some "horrible examples" of intermittents the writer has personally run into during his checkered career:

Intermittent collapse of vertical sweep. This was due to a spot of electrolytic corrosion on the height control. Controls of any kind left unmoved for a long time may develop corrosion like this, because of electrolytic action between dissimilar materials.

Severe bending and weaving, plus very bad horizontal sync, when the set was first turned on. This trouble showed up only in the home, early in the morning. After a warm-up of 30 minutes, the set played perfectly for an indefinite period. Operation was faultless at all times in

NOW test all the latest tubes

THIS NEW DELUXE TUBE TESTER tests 9-pin NOVARS, 12-pin COMPACTRONS, new 10-pin tubes and NU-VISTORS plus all previous standard tube types. The Model 107A is the finest, fastest tester at a popular price—offers every important test you need! Dynamic Mutual Conductance Test on pre-wired chassis, Cathode Emission Test by free point selector system and the nationally accepted Grid Circuit Test patented by Seco—up to 11 simultaneous checks for leaks, shorts and grid emission. In handsome carrying case with handy chart for tube set-up data.



NEW SECO MODEL 107A \$149⁵⁰ NET

Meets specifications for Federal Stock Classification. Government Agencies use Part No. Tube Tester Type 107-FSN-6625-713-9075.

COMPACT, PORTABLE, LOW-COST TESTER.

Ten sockets offer complete modern TV tube coverage plus all heater-type radio tubes and hybrid types. Includes sockets for all latest types—NU-VISTOR, 9-pin NOVAR, 10-pin tubes and 12-pin COMPACTRONS. Incorporates the patented Seco Grid Circuit Test plus reliable Cathode Emission Test . . . also checks filament continuity and provides open element test. One easy-to-read meter indicates results of all tests. With portable carrying case and flip chart for quick set-up data.



NEW SECO MODEL 88 \$69⁵⁰ NET

MODEL 100 DYNAMIC TRANSISTOR CHECKER—checks transistors "in" or "out" of circuit. Permits matching of similar transistor types. No set-up necessary. **\$19⁹⁵ NET**



MODEL GCT-9 GRID CIRCUIT TUBE TESTER—tests for grid emission, leakage, shorts and gas in one operation! Two new exclusive tests—cathode continuity check and interelement short test with short identified to pin number. **\$32⁹⁵ NET**



two-way radio test equipment



TWO-WAY RADIO TESTER
Reduces servicing and installation time of crystal-controlled units. Combination Crystal Checker, RF Signal and Field Strength Meter. Model 500. **\$29.95 Net**



TRANSMITTER TESTER
Designed especially for use with Citizens Band and other low transmitters up to 160 MC. Checks percentage of amplitude modulation as well as RF power output. Model 510. **\$46.95 Net**



ANTENNA TESTER
A commercial quality in-line antenna efficiency tester and in-line RF power meter. Antenna testing is made easier and faster on wide range of transmitters employing 50 ohm transmission lines. Model 520. **\$42.95 Net**



ATTENU-LOAD
A dual purpose unit in one compact package. 50 Ohm, 50 Watts Attenuator and Load Termination. Model 511A. **\$21.50 Net**

Send for your **FREE** copy of the Seco Full Line Folder. Complete details on all quality Seco Testing Equipment including:

- VACUUM TUBE VOLT METER**
Model 208. **\$74.50 Net**
- BATTERY ELIMINATOR**
Model PS-2. **\$13.95 Net**
- IN-CIRCUIT CURRENT CHECKER**
Model HC-6. **\$12.95 Net**
- FLYBACK CIRCUIT AND INDUCTANCE ANALYZER**
Model FB-4. **\$38.95 Net**



SECO ELECTRONICS, INC.
5031 Penn Ave. So., Minneapolis 19, Minn.
Please send information on MODELS . . .

Full Line Folder 107A 88 500 510 520 511A GCT-9 100 208 PS-2 HC-6 FB-4

Name _____
Address _____
City _____ State _____

GETTING STARTED IN CITIZENS RADIO?

You will do right for yourself and your customers when you install MOSLEY base station antennas!

Old timers in Citizens and other 2-Way Radio work will tell you that MOSLEY antennas are respected throughout the industry for dependable performance and rugged durability. They can cite many cases where communications range — and customer appreciation — were significantly increased by simply switching to a MOSLEY antenna!

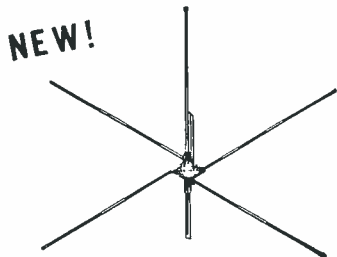

Model V-11-UGP

Omni-directional Ground Plane Antenna

Net Price, \$21.95

Here is a low cost unity gain base station antenna you can install with full confidence that it will perform effectively . . . for many maintenance-free years!

FEATURES:

- 100% Rust Proof!
- Heavy-Wall, Heat Treated 6061-T6 Aluminum Elements!
- Vertical and Radial Elements Grounded for Positive Lightning Protection and Improved Signal to Noise Ratio!
- "Cyclac" Base Supports Vertical Without Guys in Winds Up To 75 mph!
- Low Angle of Radiation for Greater Range!
- 360 degree Radiation Pattern!

MOSLEY MAKES A COMPLETE LINE OF FINE BASE STATION AND MOBILE ANTENNAS FOR BOTH 27 MC. CITIZENS BAND AND FOR THE VHF 2-WAY BANDS.

Write for free Catalog.

Mosley Electronics, Inc.

4610 N. Lindbergh Blvd. — Bridgeton, Mo.

the shop. The cause was moisture condensation on a PC board, due to using an open-flame gas heater in the home on chilly mornings. This caused leakage from an 80-volt AC (filament-string) terminal located between two horizontal AFC terminals on the board (point A in Fig. 3), which upset horizontal sync. After the chassis has warmed up enough to dry off the film of moisture, the symptoms disappeared and could not be brought back. The cure: Clean the PC board, spray it with several coats of acrylic plastic, remove the wire jumpers from point A, and make a new wire jumper to bypass this terminal.

If you want to know how I *really* found the cause, I'll tell you. The chassis was standing on edge, with the bottom of the PC board toward me, producing the customary perfect picture. I looked at it in the mirror, and heaved a tremendous sigh of utter despair. The moisture from my breath hit just the right place, and the picture suddenly buckled and fell out of sync! I found that I could literally "blow it out of sync" by breathing on it! (Electronic halitosis?)

Intermittent loss of high voltage. I could smell a distinct ozone odor and hear a characteristic corona hiss. However, no corona was visible. It was finally located by observing the set in a pitch-dark room. As the raster faded, a "ring of fire" appeared around one of the two special 2-megohm HV filter resistors. Paint on the resistor had concealed the fact that it was completely broken in two. Contact between the halves remained OK, however, until the set warmed up.

Intermittent loss of picture and

raster. In this one, the "king of them all," the raster shrank to half the normal width, fell out of horizontal sync, stayed for three to five seconds, and then disappeared. This happened after two hours and fifteen minutes of operation, in the home only. If a technician was watching, it played for an indefinite period. In the shop, this set was under actual observation for a total of more than 120 hours without developing the trouble. *All* parts in the high-voltage section (including the 1B3 socket), plus the horizontal sweep tubes, yoke, flyback, and oscillator transformer, were replaced. Line voltage was measured at the home (7 miles out in the country), and the AC input to the set was varied in the shop, without uncovering any clues.

The cause was finally found to be a thermal short in the picture tube, between the accelerator grid (pin 10) and filament or cathode—probably between the side rods or base leads. Here's an analysis: The short overloaded B+ boost; this affected the plate supply to the horizontal *oscillator*; a drop in drive-signal amplitude then lowered boost still further and extinguished the raster. Enough drive evidently remained to keep the plate of the horizontal output tube from running red hot. A cure was accomplished by installing a special transformer-type CRT brightener which isolated the shorted elements from ground. The same picture tube is still in use, four years later. Total net loss of income? Incalculable! Luckily, this set was one in a million. It's made me grateful for one thing, though; since it was on my bench, all other troubles have seemed simple by comparison. ▲

THE *NEW* DYNAMIC RAPID TROUBLE SHOOTER

METREX GENIE

POCKET-SIZED — TRANSISTORIZED SIGNAL GENERATOR

Tunable 50 cy. to 3.3 mc.

7 INSTRUMENTS IN ONE!



Pat. Pend.



FUNCTIONS AS • RF • IF • AUDIO VIDEO • PULSE • BAR GENERATOR & VOLTAGE CALIBRATOR

Services — RADIO, TV, HI-FI, RECORDERS, PHONES AND INTERCOMS

The GENIE has a tunable range of 50 cycles to 3.3 mc. Output variable from zero to 9 volts peak to peak. The uniquely designed circuitry makes possible unusually stable operation and extremely low battery drain. The rugged diecast housing insures extreme durability and perfect shielding. 2 3/4" x 3 1/2" x 2" size is ideal for shop, lab, and field use.

1495
less
Batt.

WRITE TODAY FOR FREE TROUBLE SHOOTING GUIDE

METREX 519 HENDRIX ST., BKLYN 7, N. Y.

PRODUCT report

For further information on any of the following items, circle the associated number on the Catalog & Literature Card.

Picture-Tube Brighteners (43G)

As implied by the slogan, "If the base is right, the boost is right." Perma-Power "2-Brite" picture-tube brighteners can be installed on any black-and-white CRT without concern for heater voltage or current ratings. Three base styles are supplied: Duodecal (Model C-202); small, wire-pin 110° (Model C-212); and Sylvania-type 110° (Model C-222). List price of each model is \$3.75.



Audio Control and Amplifier Units (44G)

In Fisher "Stereo Master Control-Amplifiers," dual-channel power amplifiers are combined with input, preamp, and control facilities. Many unusual features are included, such as a "stereo dimension" control, a center-channel speaker output requiring no third amplifier,



and an internal switching system for tape monitoring. The Model X-101-B (shown) has a music power output of 26 watts per channel, and is priced at \$189.50; the more elaborate X-202-B, with 35-watt output per channel, is \$249.50.

Paging Speaker (45G)

A compact, weatherproofed sound projector for paging, the Electro-Voice Model PA15, has a program-power capacity of 15 watts and a sound-dispersion pattern 120° wide. Frequency response is 350-13,000 cps, with normal voice frequencies emphasized to make spoken announcements more in-



telligible. The die-cast housing has a neutral tan finish. List price of the standard 8-ohm version is \$30; optional at extra cost are a 45-ohm version and another with a built-in 70.7-volt matching transformer.

Tube-Tester Modernizing Panel (46G)

The Sencore Model TM116 "Tube Tester Modernizing Panel" adapts any tester (except an automatic card-operated type) to make the same tests on "Compactrons," "nova" tubes, "nivistors," and 10-pin miniatures as on conventional tubes. Tests are made by plug-



ging the adapter into an octal socket on the main tester and referring to a chart provided with the adapter. The dealer net price of the TM116 is \$24.95.

21" Picture Tube (47G)

A new "universal-type" picture tube, the General Electric 21FLP4, can be satisfactorily substituted for any of the following types: 21CBP4, -A, -B, 21ALP4A, -B, 21ATP4, -A, 21BAP4, 21BNP4, 21BTP4, 21CMP4, 21CVP4, and 21CWP4. Equipped with a straight gun, the tube requires no ion-trap magnet. The phosphor is a new high-temperature type designed for improved picture clarity and brightness. List price is \$45.90.

CORRECT
OVER VOLTAGE

CORRECT
LOW VOLTAGE



and get BETTER PERFORMANCE with this ACME ELECTRIC VOLTAGE ADJUSTOR

TV sets, hi-fi's and other electronic equipment operate best when voltage holds closely to the normal 115-117 volts for which they were designed. Over-voltage and/or under-voltage affects the performance of the tubes and the life expectancy of all other components. Why fight an off-standard voltage condition? Correct it with an Acme Electric T-8394M Voltage Adjustor.

Corrects voltage over a range from 95 to 125 volts to normal 115/117 volts, simply by turning a regulating switch. Includes voltmeter which indicates output voltage; cord and plug and built-in, plug-in receptacle. Tell your supply dealer you want the Acme Electric T-8394M Voltage Adjustor. No other so compact, complete, practical, inexpensive.

SA 3402-1849

ACME ELECTRIC CORPORATION

9410 WATER STREET

CUBA, N.Y.

Acme  Electric



"Spotlight Specials"

Look for them at
your distributor
and **SAVE!**

Need some
new drivers?
Doesn't everyone?

Well, right now is the time to get them and genuine VACO drivers at that! These are the drivers with the world's most comfortable handles and with rugged blades of chrome vanadium steel. All unconditionally guaranteed. Now available at these special prices!

	Genuine Phillips Drivers	Only \$.69 ea. net
	Reversible Screw Drivers	Only \$ 1.19 ea. net
	Popular Size Round Blades	Only \$.69 ea. net
	Hollow Shaft Nut Drivers	Only \$.75 ea. net

VACO PRODUCTS COMPANY
317 East Ontario Street, Chicago 11, Ill.
In Canada: Vaco-Lynn Products, Ltd. and Atlas Radio Corp.

\$26³¹ puts you in the TV KNOB BUSINESS

- Dealers Exact replacement TV Knob Deal
- Helps build extra profits
- Knobs same as original
- pre-packaged and clean
- free display merchandiser
- pre-priced for full profit



ADMIRAL DEAL NO. 49-573
DEALER NET 26.31

Here's immediate availability of the most popular exact replacement TV knobs, each individually skin-packed and priced. Shown are Admiral knobs, but exact replacement knobs are available for all seven leading TV manufacturers. Complete model number to GC number cross reference guide with each display order.

See your GC Electronics Distributor, or write.



GC ELECTRONICS COMPANY
a division of Tectron Electronics, Inc.
 400 S. WYMAN ST., ROCKFORD, ILLINOIS

The LUXO MAGNIFIER

is designed for precision seeing . . . in the shop, on the assembly lines and inspection stations.

The Luxo Magnifying Lamp's large magnification and cool fluorescent light increases visual accuracy during assembly, when working with printed circuits, or reading small parts numbers.

It is ideal for maintaining quality control.

FEATURES AND SPECIFICATIONS

- 3 Diopter, 5" Diameter distortion-free glass lens.
- Magnifier adjusts to any position with finger-tip ease and stays put! Easily turned out of way when not in use.
- Luxo Lamps can be mounted or positioned anywhere.
- Also available in LFM-2 and LFM-9 Models.
- UL approved.

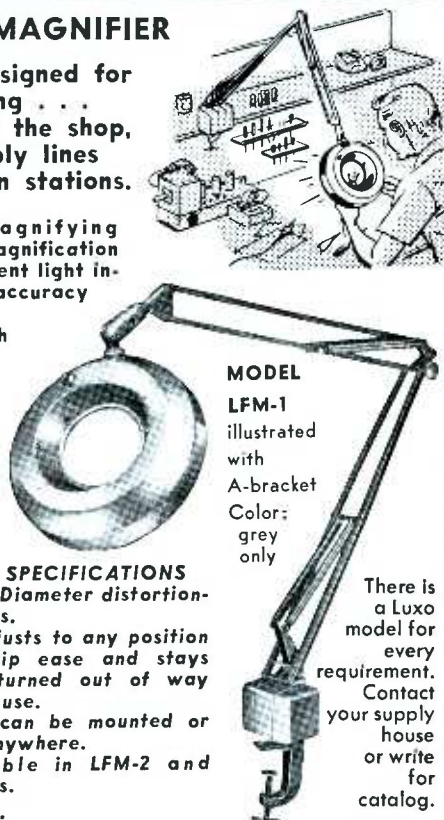

MODEL LFM-1 illustrated with A-bracket
 Color: grey only

There is a Luxo model for every requirement. Contact your supply house or write for catalog.

LUXO LAMP CORPORATION
 San Francisco, Cal. • PORT CHESTER, N.Y. • Montreal, Que.

Mobile Antenna and Base (48G)

A lightweight, stainless steel ball and spring mount for mobile communications antennas. New-Tronics Model NTS-1, fits standard mounting holes and can be installed by one man. Similar units are available in cadmium-plated or chrome-plated steel. Another new product, the Model CB-27 telescoping whip antenna, collapses to 27" and extends to 60". The top section of this antenna has an etched scale for accurate tuning to either the 27-mc Citizens band or the 28-30 mc amateur band.



Transistorized Antenna Amplifier (49G)

Mounted directly at the antenna terminals, the JFD "Transis-Tenna" TV/FM signal amplifier increases the signal-to-noise ratio and drives one to four receivers. The transistorized circuitry is powered by four size D cells located in a combination power supply and multiset coupler (mounted indoors). The amplifier system is included as an integral part of 30 new antenna models, and is also available separately.

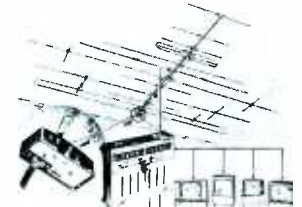

High-Fidelity Speaker Systems (50G)

The design of two new H. H. Scott compact speaker systems emphasizes multiple crossover networks, with separate mid-range and tweeter controls for precise adjustment of the system to match its "acoustic environment." The Model S-3 incorporates a low-resonance 10" woofer and wide-dispersion mid-range and super-tweeter units; the larger Model S-2 contains a high-compliance 12" woofer, two dual-cone mid-range units, and a super-tweeter. Prices east of the Rockies are: S-3, \$129.95; S-2, \$199.95.



CB Transceivers (51G)

A front-panel switch on the Gonset G-12 Series "Citizen's Communicator" simultaneously tunes the transmitter and superhet receiver to any one of four preset, crystal-controlled channels in the Class D Citizens band. The gimbal-type mounting bracket lends itself to a variety of fixed and vehicular installations. The speaker and power supply are built into the 4 1/2" x 7" x 10" case. Two types of power supplies are offered: 12V DC/117V AC in Model 3316, or 6V DC/117V AC in Model 3329.



Private TV-Listening Device (52G)

The Telex "TV Listener" permits quiet enjoyment of radio and TV wherever sound from a speaker would be annoying. Two earsets can be plugged into the plastic case of the unit at once; volume is adjusted simultaneously in both channels by a front-panel control. A 15' cord with alligator-clip terminals connects the device to a receiver or amplifier. The earset furnished with the "Listener" can also be used with transistor radios. List price is \$14.85.



Molded Tubular Capacitors (53G)

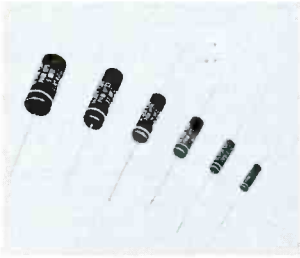

Featuring a dual dielectric (paper and polyester film), a solidified "Fixfil" impregnant, and molded plastic cases, **Cornell-Dubilier** Type PKM "Black Cat" tubular capacitors are obtainable with voltage ratings of 200, 400, 600, 1000, and 1600V over a capacitance range of .001 through 1 mfd. Standard tolerance is $\pm 20\%$, but closer-tolerance units are available.

Speakers for Electronic Organs (54G)

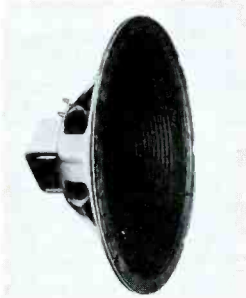

The sustained very-low frequency notes generated by electronic organs tend to break down conventional speakers. Therefore, **Utah** has introduced two 12" speakers designed to withstand this type of service. Models OR 12J-8 (with 8-ohm voice coil) and OR 12J-16 (16-ohm) both have 6.8-oz. Alnico V magnets and are rated to handle 15 watts of peak audio power.

Replacement Tape Heads (55G)

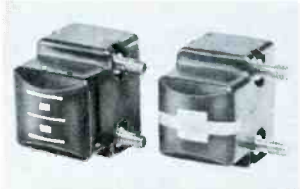

Two series of magnetic heads for tape recorders have been announced by **Sonotone**. Monophonic record/reproduce heads in the RH-2 series have a list price of \$10 each, and matching EH-2 erase heads are \$9. Four-track stereo record/reproduce heads (RH-4 series)

are \$28.50; these also have matching erase heads (EH-4 series—\$13.50). Stereo units feature a balanced-winding magnetic circuit for low hum sensitivity.

Transmitter Test Equipment (56G)

A combined T-pad power attenuator and noninductive load-resistance bank, the **Seco** Model 511A "Attenu-Load," is useful as a dummy load for a transmitter, as well as for coupling the transmitter to any load that requires a 10:1 power reduction. The 511A permits using the companion Model 510 transmitter tester at RF power levels up to 50 watts.



Soldering Tools (57G)

A "Kormat" wire-solder dispenser and a 100-watt Model 8100B soldering gun are included in a new **Weller** kit. The hand-held, thumb-operated dispenser handles all sizes of solder from .028" to .074", and reloads in 30 sec. This Model WK81 soldering set is offered at a special combination price of \$9.95.



Aerosol Sprays (58G)

A new "Sargent" line of electronic chemicals and finishes in 16.4-oz. aerosol spray cans has been introduced by the **Sargent-Gerke Co.** Items available include "Red Insulator" for high-voltage circuits, tuner cleaner, parts cleaner, clear acrylic plastic, penetrating oil, degreaser, squeak stopper, enamels, lacquers, metallics, stop-rust, and specialties. Supplied with each can is a removable plastic extension tube for pinpoint applications.



NEW TUBE TYPES ARE REVOLUTIONIZING YOUR BUSINESS

We promised you the answer and here it is...

NEW TUBE TESTER MODERNIZING PANEL

Now, you can test all of these new tubes in the Sencore Mighty Mite or any other tube tester except the "cardomatic" type. Don't throw away your tube tester just because you can't check the RCA Nuvistors, the GE Compactrons, the Sylvania 10 pin tubes or the all new RCA Novars.

These new tubes, which are the industry's answer to the transistor, are causing a revolution in electronics today. Thousands are being installed in electronic equipment every day from coast to coast. You will be called on to test them tomorrow. Be prepared with the TM116 Tube Tester Modernizing Panel.

For use with any manually operated tube tester.

Tests are made by plugging the TM116 into an octal socket on your tester and setting controls from the chart provided with the unit. All tests are the same as your tester now makes. Some other adaptor units merely reduce all tests to an emission check. Sencore uses additional internal circuitry to provide complete mutual conductance or high grid leakage checks if

your tester now makes them. You can own the TM116 for less money than it costs to keep substitutes in your shop or lab. Model TM116 Dealer Net Only.....

\$2495

Ask your Authorized Sencore Distributor for the New TM116. He has them in stock.

SENCORE

ADDISON, ILLINOIS

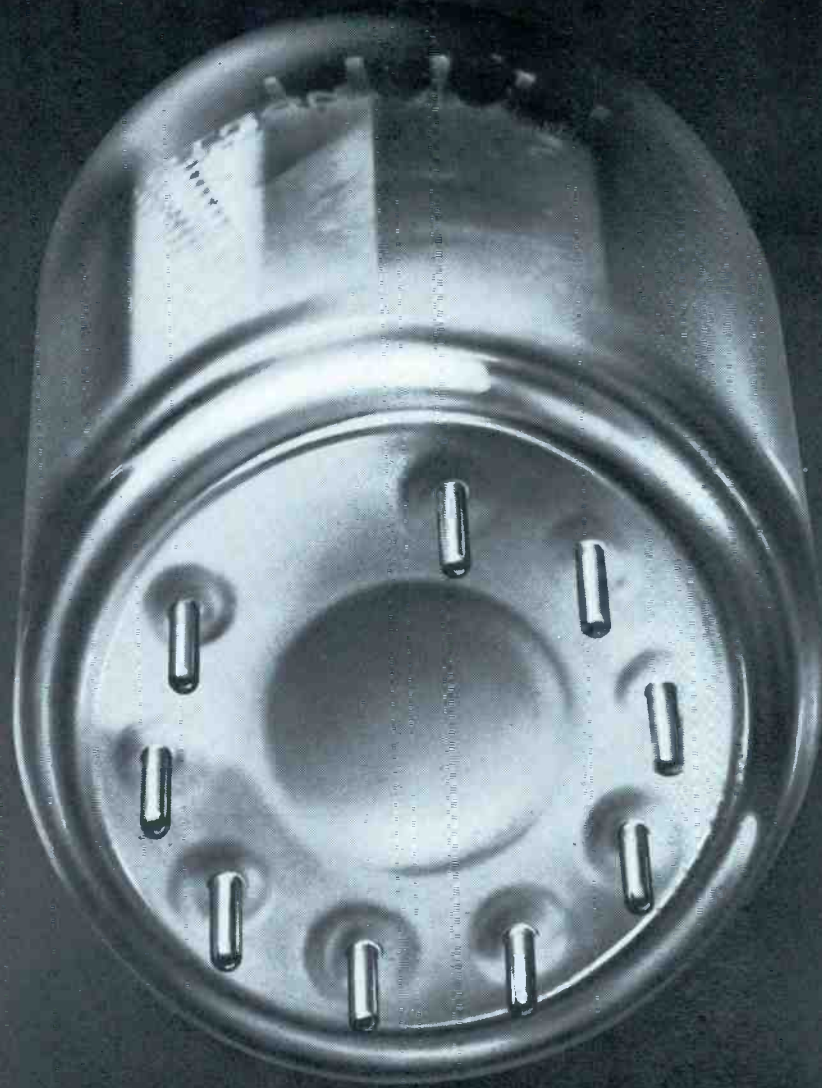

“BUSINESS END” of a NOVAR tube

You're looking at the base of one of RCA's remarkable new novar tubes...the first in a new family of tubes that will mean better business for you through reduced call backs.

This new base—with 9 widely-spaced, heavy-gauge pins—characterizes novar, RCA's line of large all-glass integral base tubes designed to do the work of conventional tubes with molded bases. Because novars *outperform* these con-



ventional types, they are being selected for use in more and more radio and TV receivers as well as hi-fi equipment. From present indications, novar should become the standard of the industry.

Look for novar, RCA's latest contribution to electron tube design. Your Authorized RCA Electron Tube Distributor now has RCA-7868 novar and will soon have many other types to support your servicing business.

RCA ELECTRON TUBE DIVISION, HARRISON, N.J.



The Most Trusted Name in Electronics

WHAT'S IN A FUSE?

Only a fuse element, glass & caps?

No! Every fuse carries
with it the skill and quality of its manufacturer.

You can't reach out and touch or taste this,
you can't even be sure it will do
its job when needed except
by purchasing from a company
that has the know how of 30 years
of manufacturing fine fuses.

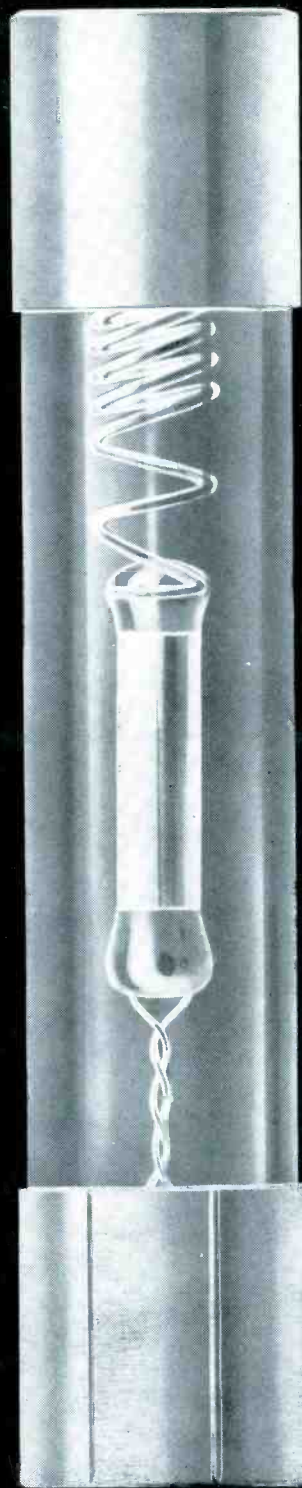
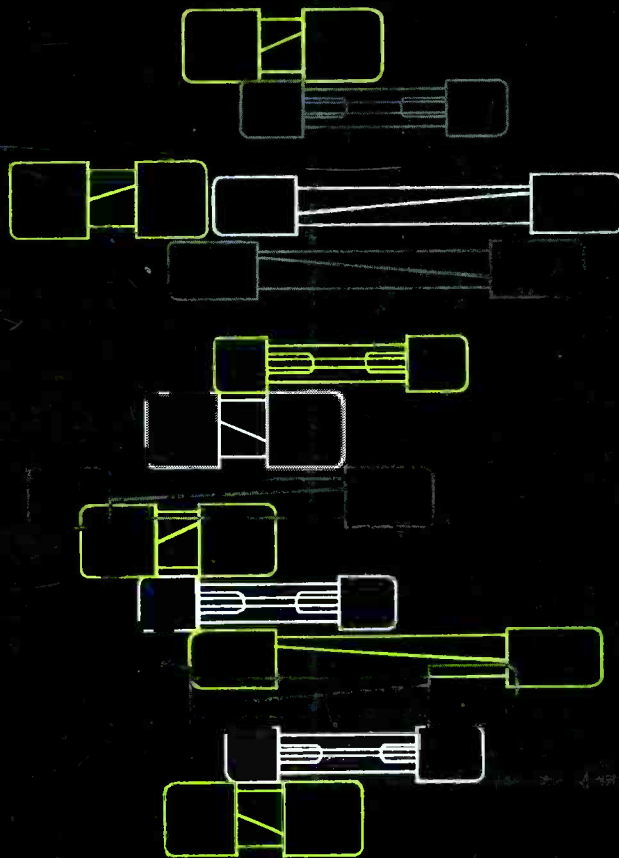

BURTON BROWNE ADVERTISING

LITTELFUSE

1865 Miner Street Des Plaines, Illinois