

JULY, 1959 35 CENTS



THE RADIO REPORTER®

Including **Electronic Servicing**



TV Tuner Alignment

Repairing Clock Radios

P's and Q's of Transistors

Servicing Electronic Organs

1A 9H 635 1260E
WM M DAVIS
118 RIVERSIDE AVE
CANON CITY COLO

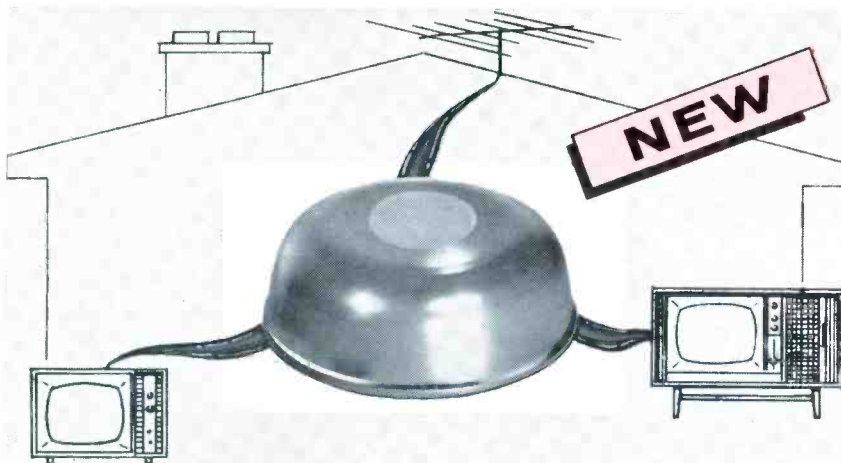

Walsco 2-Set TV-FM Couplers

A Walsco Exclusive . . . both these couplers can be mounted on wall or mast before attaching leads. Standard Model for strong signal areas; Low Loss Model for fringe areas.

No. 1600 Standard List \$2.50
 1602 Low Loss 3.50



WALSCO STRIP-ER CLIP

New precision tool with accurate dial for stripping each wire size. Clips all wires from 12 to 26 gauge. Ground cutting edges, insulated grip.
 No. 595-X. List \$2.30



WALSCO LONG NECK OILER

Reach all those hard-to-get oil cups, etc. All plastic container and nozzle; telescoping extension reaches 7 inches. Contains high quality all-purpose oil.
 No. 985 List \$1.50



WALSCO C-RING TOOL

Specially designed to remove and insert "C" washers and retaining rings on tuners, control shafts, etc. High grade steel, nickel plated.
 No. 585 . . . List \$3.15



WALSCO STICKLEBABY

The only hand tool that drills and saws in any direction. Excellent for veneer work and fine carpentry. Combination drill, saw and rasp.
 No. 586-00 . . . List \$1.63

More For You . . . And The Price Is Right!

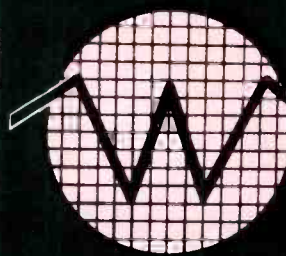

WALSCO ELECTRONIC PRODUCTS

Everything You Need For Better Servicing



ROUND

WALSCO CHASSIS PUNCHES



SQUARE

Make better chassis holes faster with Walsco's "Low-Torque" Punches. Specially hardened, precision ground tool steel; easy to use. Complete line of sizes and styles.



KEYED



"D"



WALSCO HEX & SPLINE KIT

Contains 11 of the most popular size hex and spline wrenches in durable plastic snap case. High grade alloy steel.
 No. 560 List \$2.25



WALSCO 100-PAK HARDWARE

All the quality electronic hardware items you need in convenient 100-to-a-box packages. Look for the Walsco Display at your jobber.



WALSCO PHONO DRIVES

The only complete line of replacement phono and recorder drives and belts on the market. Includes all the new model turntables and changers.

FREE! Write for your Walsco Catalog. Send postcard today.

Walsco ELECTRONICS MFG. CO.

Division of Textron Inc.

West Plant: Los Angeles 18, California

Main Plant: ROCKFORD, ILLINOIS, U.S.A.

Canada: Atlas Radio Corp., Ltd., Toronto 19

YOU CAN GET WHAT YOU WANT FROM WALSCO!

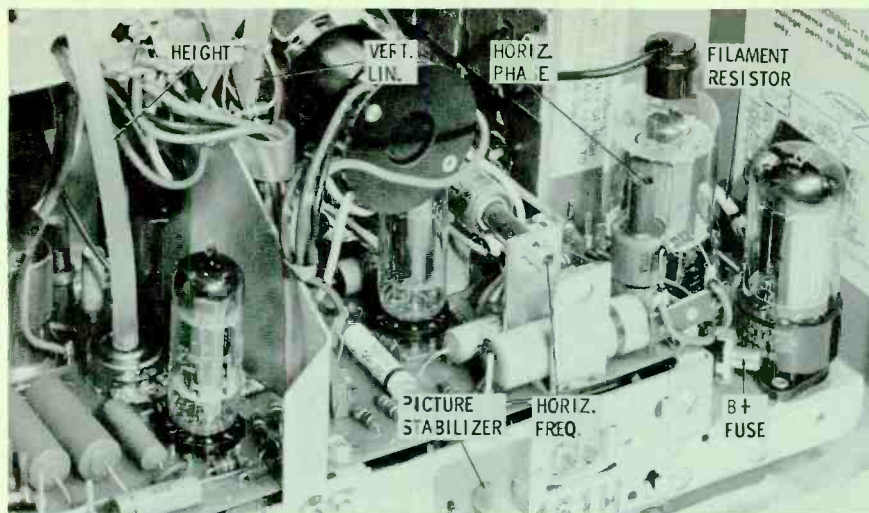

**Emerson Model 1506
Chassis 120451H**

This 17" portable has all operating controls on the side, and a four-section telescopic dipole attached to its rear cover. The side controls include a channel selector and fine tuning, horizontal hold, vertical hold, brightness, and volume with on-off switch.

Taking a look in the back of the cabinet, you'll find a rather small horizontal chassis with tuner and controls mounted on vertical brackets. The "hot" chassis drives a 17AVP4A 90° picture tube and 4" PM speaker. The filament resistor shown in the photograph is a 1-ohm fusible type soldered in a series circuit. The B+ fuse is a 1-amp slow-blow unit protecting the low-voltage supply. Remember that the horizontal frequency and phase coils require a nylon hex-head tool for adjustment.

Tubes in the series string are fairly conventional except perhaps for the 12CU5 type in the audio output stage. Speaking of tubes, you may find it a little difficult to reach some of them with the chassis in the cabinet. To pull the chassis, remove the Phillips-head screw on the side near the control knobs and also the 1/4" hex-head screw holding the tuner brace to the top-rear corner of the cabinet. After yoke, ion trap, high-voltage lead, and speaker are freed, take out the four bottom chassis bolts and slide the assembly out the back. Actually, you'll only find about ten small circuit components located under the shallow chassis.

On the front section of the chassis, which is not exposed from a rear view of the cabinet, you'll discover a silicon power rectifier hidden beneath the upright control bracket. You will note, too, that it is soldered into the power-supply circuit on a small terminal strip. On the opposite side of the chassis, you'll find a 1G3 high-voltage rectifier directly in front of the high-voltage cage. Two separate printed boards are employed—one for audio, video, and IF stages and the other for both sweep circuits.

If it becomes necessary to clean the safety glass and screen on this portable, remember that the mask assembly comes off from the front. Merely remove the two 1/4" hex-head screws from the bottom of the mask and pull the assembly out and up as shown.

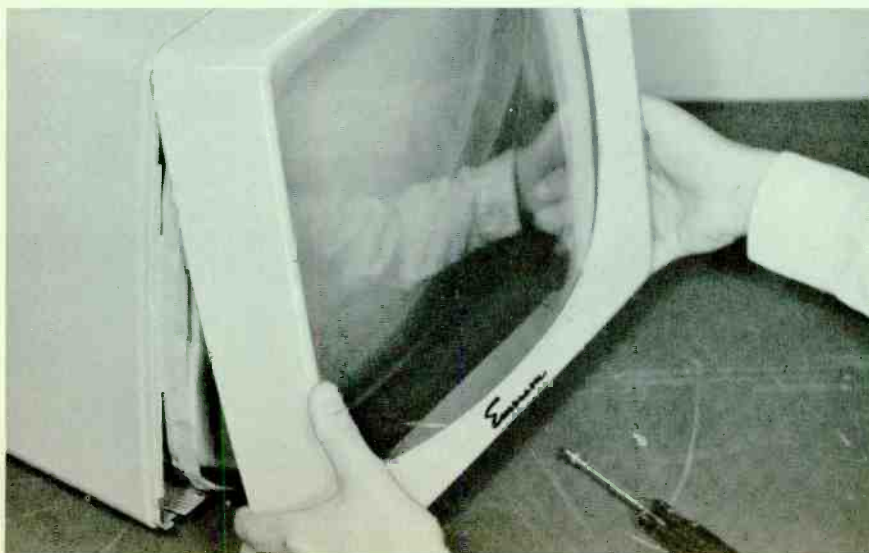
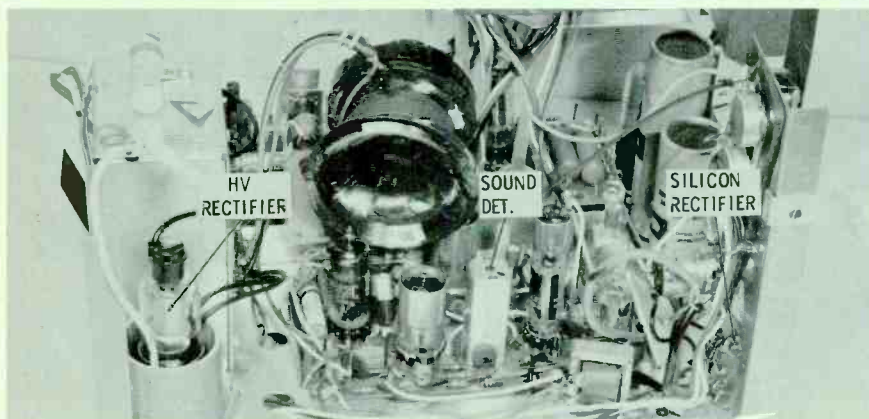
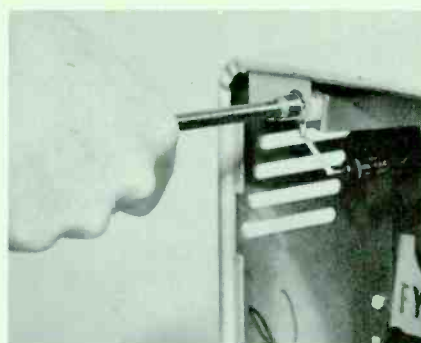
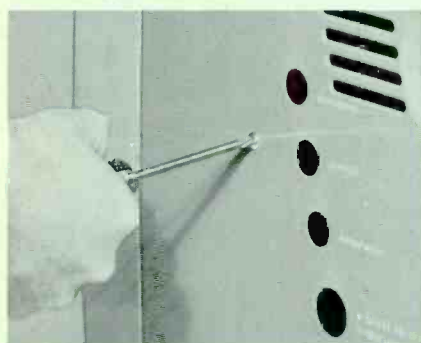

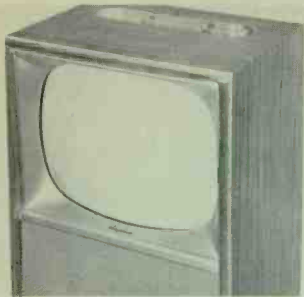

**Magnavox
Chassis V29-0500**

With console styling, this new set features a 21" screen, operating controls on top, and dual 8" PM speakers. The safety glass on this model can be removed from the front by taking out the four wood screws which hold the top trim strip, and tilting the top of the glass forward.

Removing the back from the set, you'll find a conventionally-wired vertical chassis built around a 21DLP4 90° picture tube. Powered by a transformer and single 5U4GB rectifier, the chassis and CRT are both mounted on a board which is held in the cabinet by six bottom bolts. The high-voltage fuse pointed out in the photograph is a snap-in, slow-blow type rated at ¼ amp. All tubes, none of which are uncommon, are within easy reach, except for the two mounted in the tuner behind the top corner of the chassis.

Most of the service adjustments are grouped at the bottom of the chassis pan between the high-voltage cage and the power transformer. The width control is actually a slug-tuned coil which can be adjusted by moving a small lever arm back and forth along an open slot in the chassis. A small selenium dual diode is employed in the horizontal AFC stage, and is located directly above the width adjustment. This is a plug-in unit with a polarity coding marked on the chassis. The flattened corner of the diode should match up with the "+" indication stamped on the chassis.

Since the picture tube is electrostatically focused, a spring-clip jumper is placed on its base as shown. Focus may be varied by connecting the jumper between pins 6 and 10 or 6 and 2, whichever provides the sharpest picture.

Frequency of the local VHF oscillator can be adjusted in the field from the rear of the chassis. This adjustment should be made if the fine-tuning control will not bring in both picture and sound, or if it tunes only at one extreme of its range. Each channel slug is accessible through a hole in the tuner cover as pictured. Be sure to use a non-metallic screwdriver no more than ¼" in diameter.

As with many of the newer sets, this model also features special speaker connections for use in the reproduction of stereo sound. The stereo panel mounts on the back of the cabinet with its terminals connected directly to the pair of speakers.

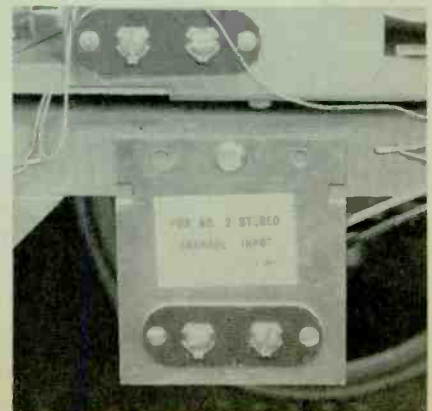
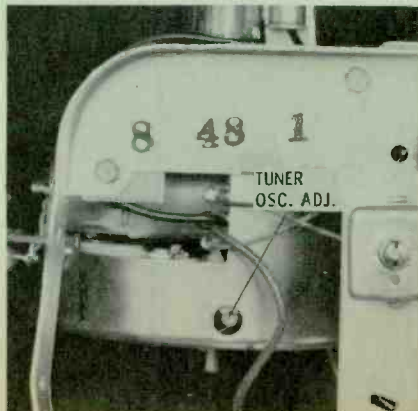
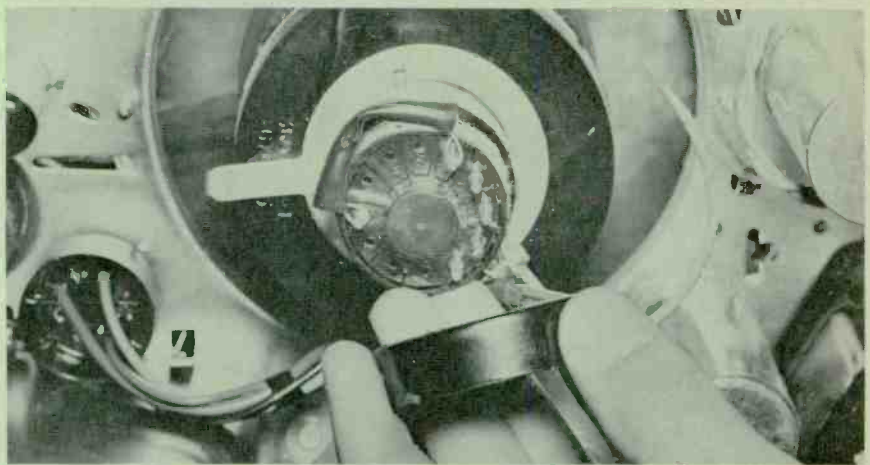
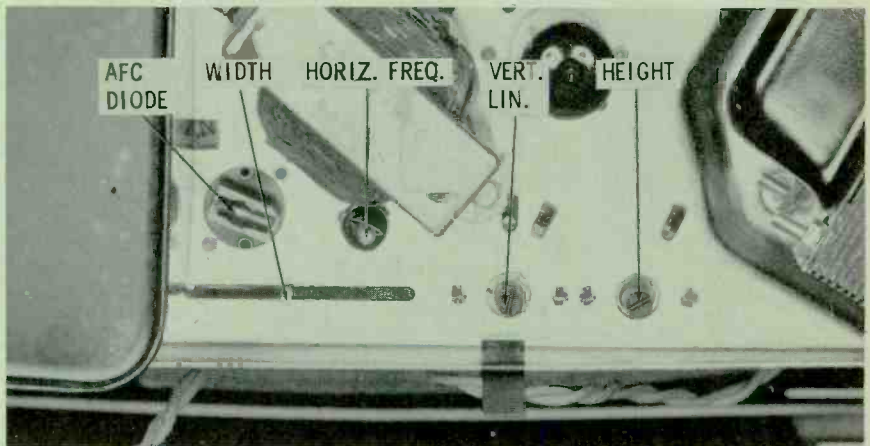
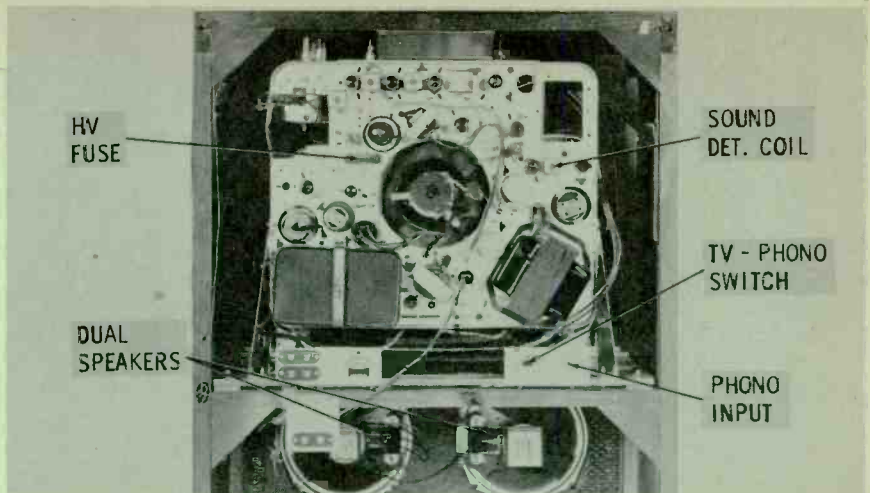

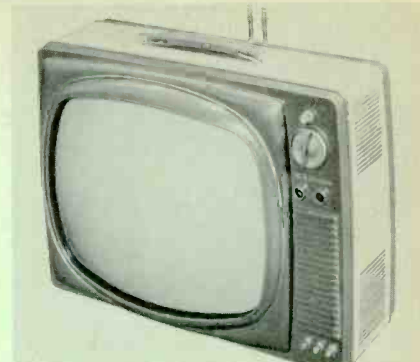
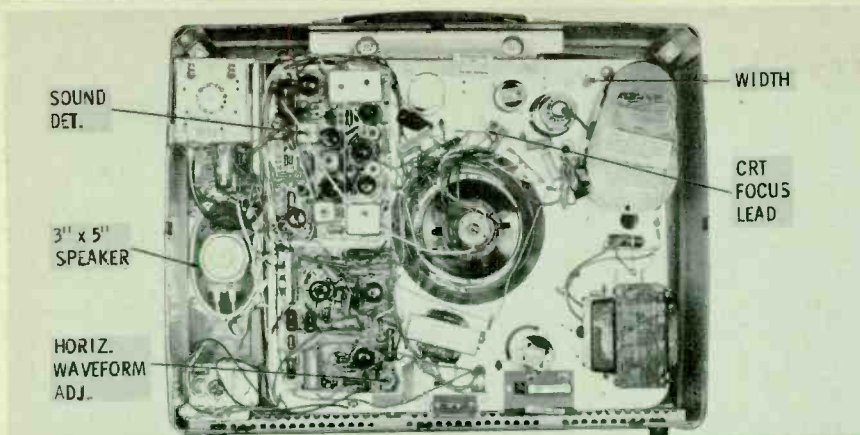

**RCA Model 170P048
Chassis KCS 126A**

Meet the new *Sportable*, a 17" portable with front tuning, telescoping antenna, and only a 12" cabinet depth. On the front of the cabinet, above the channel selector, you'll find a small knob for fine tuning. The two knobs below the selector are for contrast and volume with push-pull on-off. At the bottom of the panel are both hold controls plus one for brightness.

Removing the rear cover with antenna assembly, you'll see that the chassis is vertically mounted around the neck of the 110° CRT. The *Signal Guide* VHF tuner and oval speaker are positioned on the control side of the cabinet. The horizontal frequency coil is on the same form with the wave-form coil; however, the frequency coil is fixed, and is therefore non-tunable. Incidentally, it's best to use an oscilloscope when setting up the waveform adjustment.

The disc-type temperature-compensating resistor located between the high-voltage cage and power transformer is a surge limiter for the line, rated at approximately 170 ohms cold and 120 ohms hot. The horizontal drive trimmer is not located too close to the output tube, but down near the power transformer as shown.

The fusible resistor at the base of the chassis pan is a special plug-in unit (No. 104295) which protects the fly-back and boost-supply system. A number of new tube types appear in this chassis, including a 6FV6 and 6EA8 in the tuner, a 6EW6 video IF, a 6EB8 video output and sync separator, a 6EA8 AGC keyer and sync amplifier, a 6BQ5 audio output, a 6DR7 for vertical sweep, and a 5AS4A as low-voltage rectifier.

Two separate printed wiring boards are employed. The boards are new and different in that, on the component side of each, you'll find a phantom layout of the wiring to enable you to circuit-trace without removing the chassis or board.

To clean the safety glass and screen, remove the front control knobs and the three Phillips-head screws under the front mask assembly. Next, take off the back and loosen the 3/8" hex-head captive bolts in each upper corner of the cabinet. Pull the bottom of the mask out slightly, remove speaker leads, and lift the front up and off.

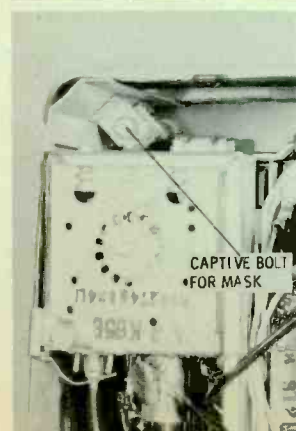
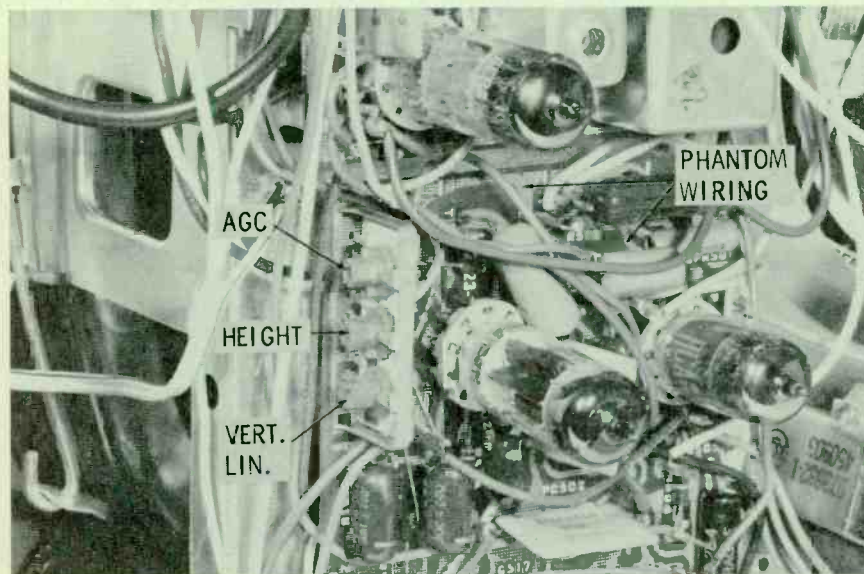
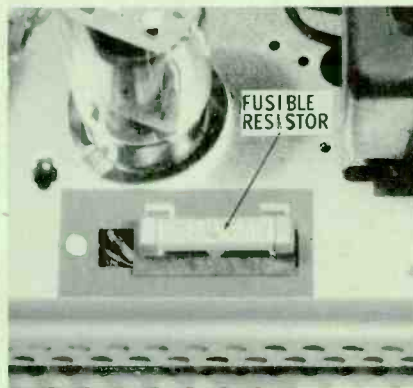
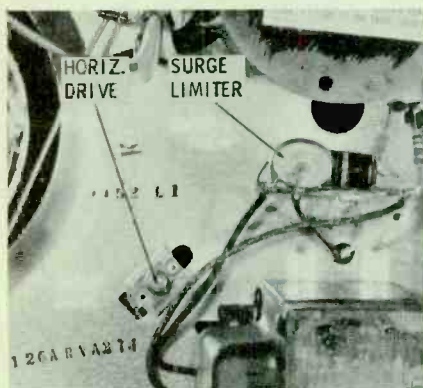

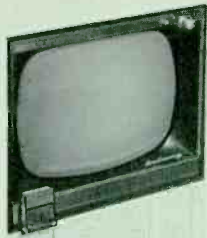

Zenith Model C3004E

Here's one of the new *Space Command* series featuring remote control, 21" 90° picture tube, and power tuning. Contrast, brightness, vertical hold, horizontal hold, and tone controls are located across the bottom of the front mask behind a hinged panel. Vertical linearity, height, AGC, and focus adjustments are also accessible with this panel open.

The chassis is conventionally wired and mounted horizontally, and employs a power transformer. All tube filaments are connected in parallel. A separate receiver chassis for the remote control system is positioned along one side of the main TV chassis as shown. The fuse, located on top of the TV chassis near the power transformer, is a 700-ma unit protecting the B+ circuits. A 6EB8 is used in the video output and sound IF stages, a 6CY7 in the vertical sweep section, a 6EA8 in the horizontal AFC-oscillator circuit, and a 5V3 is employed as low-voltage rectifier. Other recent tube types include a 6BU8 as AGC, noise limiter, and sync separator; and a 1J3GT high-voltage rectifier.

The VHF tuner is a separate assembly attached to the top section of the cabinet. It incorporates the automatic channel-selector mechanism shown in the photo, and uses a 6ES5/GG RF amplifier and 6CG8A mixer-oscillator. To set up automatic selection of certain channels, turn the selector knob manually to the desired channel number. With the back on, use a screwdriver to turn the index tab so that it points toward the tuner shaft. For undesired channels, the tabs should point in the rotating direction of the index wheel.

The remote system operates by supersonic vibrations which are radiated when the tuning rods within the remote band unit are keyed.

A microphone on the front of the remote chassis picks up the supersonic waves and converts them to electrical energy for sound muting and channel selection. The remote receiver chassis is shown here with relay cover removed.

To take out the safety glass for cleaning, a metal strip must be removed from the bottom of the picture tube mask. After pulling straight out on the small trim piece as shown, remove the two Phillips-head screws and the metal retaining strip; then tilt the glass out at the bottom and slide it downward.

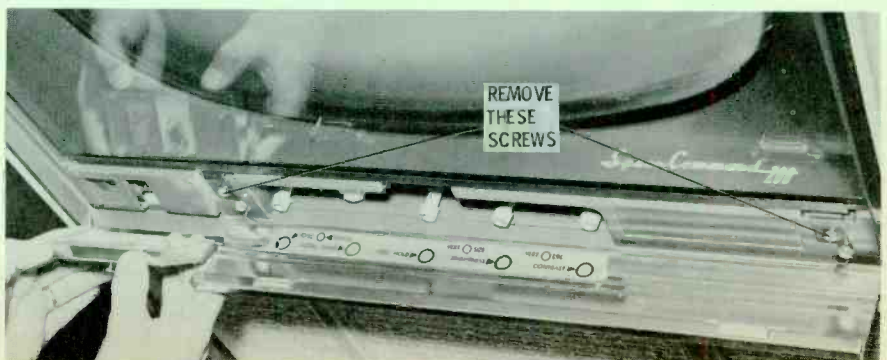
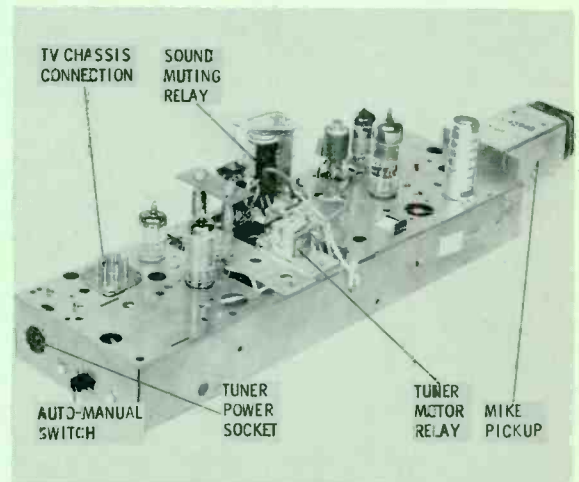
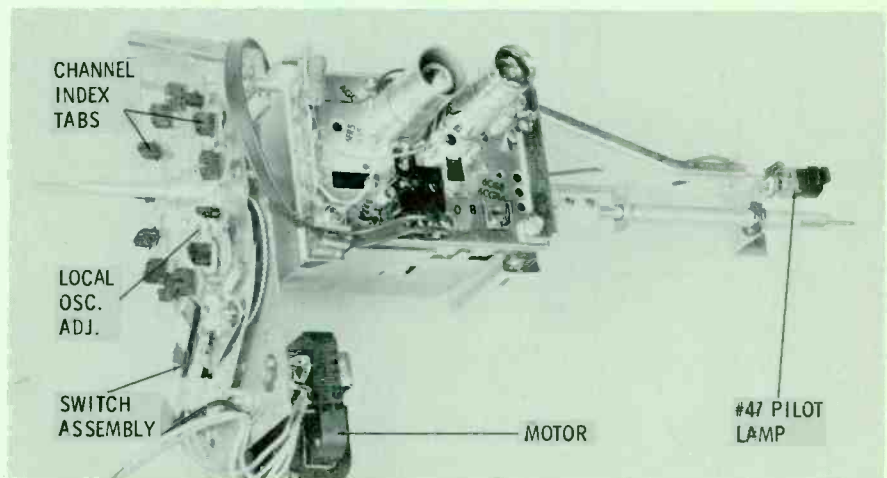
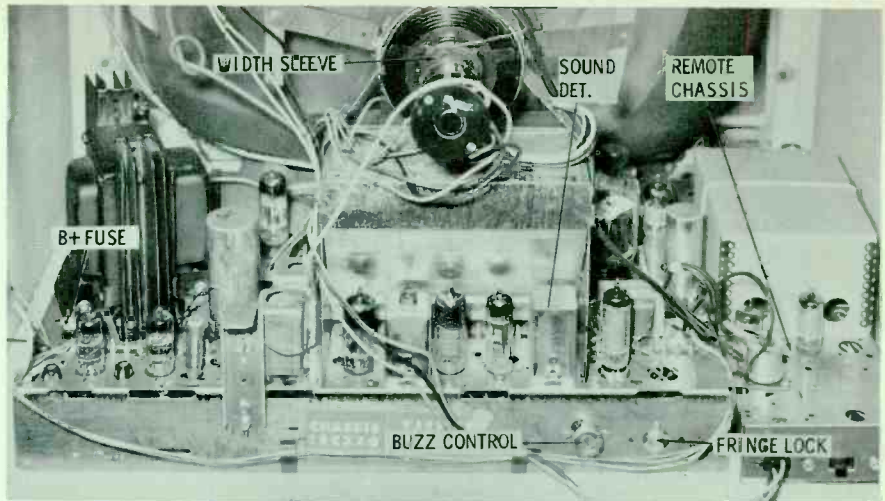

Simply by checking
all the tubes in the TV set with

B&K **DYNA-QUIK**

YOU CAN INCREASE YOUR INCOME

FAST AND ACCURATE

- Tests complete set in minutes
- Wins customer's confidence
- Saves costly call-backs
- Sells more tubes on-the-spot
- Avoids substitution testing
- Makes more money every day

\$50*
PER WEEK

***ACTUAL EXPERIENCE SHOWS
TV SERVICEMEN AVERAGE**

**2 extra tube sales
PER CALL**

**5 calls per day in
5 days equal \$50**



Completely test each tube
with laboratory accuracy!

**Model 650
DYNA-QUIK**

Today's Fastest,
Most Complete Portable

**TUBE AND
TRANSISTOR
TESTER**



**Professional-type tester
used by more service
technicians every day.**

ANOTHER PROVED MONEY-MAKER



**Deluxe Portable
CRT 400**

**Tests and Repairs
Picture Tubes
Makes New Tube
Sales Easier**

Checks and corrects most TV picture tube troubles in a few minutes, right in the home, without removing tube from set. Restores emission. Checks leakage. Repairs shorts and open circuits. Life Test checks gas content and predicts useful life. Net, \$59.95

Adapters for Models 400 and 350 CRT's
Model C40 Adapter. For standard 6.3 volt filament 110° tubes and color tubes. Net, \$9.95
Model CR48 Adapter. For the new 110° tubes with 2.34, 2.68 and 8.4 volt filaments. Net, \$4.95

MEASURE TRUE DYNAMIC MUTUAL CONDUCTANCE

Thousands of technicians are doing a better servicing job and are making more money today with the famous B&K DYNA-QUIK. Completely tests each tube in seconds, with laboratory accuracy, in home or shop. *Measures true dynamic mutual conductance.* Shows tube condition on "Good-Bad" scale and in micromhos. No multiple switching or roll chart. Quickly detects weak, short-life, or inoperative tubes. Shows customer the true condition and life-expectancy of tubes in the set; sells more tube replacements per call. Assures customer satisfaction and protects the service guarantee.

Model 650 Dyna-Quik improves servicing, quickly pays for itself

Checks over 99% of the tubes most widely used in television receivers, plus popular home and portable radio tubes. Tests over 500 tube types. Lists over 125 most commonly used tube types, with settings, on socket panels for maximum operating speed. Complete listing in fast telephone index type selector. Tests each section of multiple tubes separately for Gm, Shorts, Grid Emission, and Life. Tests each tube for Gas Content. Provides instantaneous Heater Continuity check. Includes 16 spare sockets and sufficient filament voltages for future new tube types. Transistor Section checks junction, point contact and barrier transistors, germanium and silicon diodes, selenium and silicon rectifiers. Net, \$169.95

See Your B&K
Distributor or

Send Now for
Bulletin ST21-R



B & K MANUFACTURING CO.
3726 N. Southport Ave. • Chicago 13, Illinois

Canada: Atlas Radio Corp., 50 Wingold, Toronto 10, Ont.
Export: Empire Exporters, 458 Broadway, New York 13, U.S.A.

NEW DIFILM[®] BLACK BEAUTY[®] MOLDED CAPACITORS

BEAT THE HEAT AND HUMIDITY!

Now Sprague's new DIFILM BLACK BEAUTY MOLDED CAPACITORS have taken the steam out of heat and humidity problems. These capacitors are so good you can *boil 'em* for 24 hours without affecting their performance.

Unlike straight polyester film tubulars, these capacitors operate in a 105°C environment *without derating*.

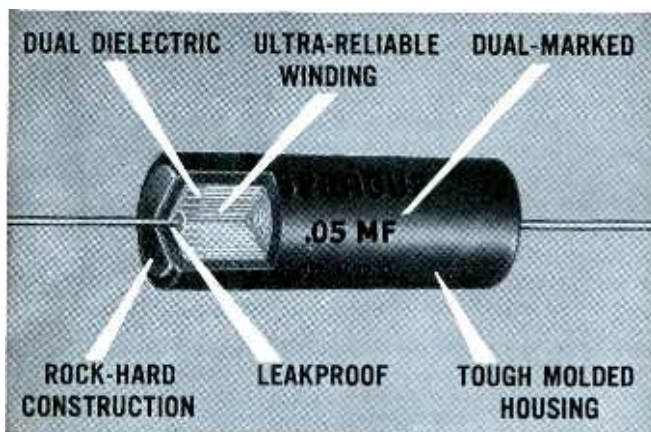

Look for the RED markings on the black case.

And the heart of these new DIFILM capacitors can't be beat. It's a dual dielectric which *combines the best advantages of both Mylar* polyester film and the highest grade of paper dielectric*. A rock-hard solid impregnant fills voids and pinholes in the film.

Talk about *reliability!* . . . these capacitors have it. DIFILM capacitors are actually low cost versions of the Sprague capacitors now being used in every modern military missile. The basic reliability and outstanding performance of missile-type Sprague capacitors are all yours in this outstanding new development. Why take chances when you can get the best—DIFILM BLACK BEAUTY MOLDED TUBULARS . . . at regular prices.

For the complete DIFILM BLACK BEAUTY story, write for Bulletin M-759 to Sprague Products Company, 105 Marshall St., North Adams, Mass.

*DuPont trademark

**The major capacitor improvements
come from**

SPRAGUE[®]

world's largest capacitor manufacturer

SPRAGUE RESEARCH IS CONSTANTLY PRODUCING NEW AND BETTER CAPACITORS FOR YOU

publisher
Howard W. Sams

general manager
Mal Parks, Jr.

editor
Verne M. Ray

associate editors
Leslie D. Deane
Thomas A. Lesh
Calvin C. Young, Jr.

consulting editors
William E. Burke
Robert B. Dunham
George B. Mann
C. P. Oliphant
Paul C. Smith

art director
Don W. Bradley

advertising assistant
Roma Barnes

editorial assistant
Georgeanna Caldwell

production manager
Robert N. Rippy

circulation fulfillment
Pat Tidd, Mgr.
Ann Mathews, Ass't.

photography
Robert W. Reed

advertising sales offices
Midwestern

John Groce, PF REPORTER
2201 East 46th Street, Indianapolis 6, Ind.
Clifford 3-6441

Eastern

Cliff Landis
Corning Glass Building,
717 Fifth Ave., New York 22, N. Y.
MUrray Hill 8-6350

Western

The Maurice A. Kimball Co., Inc.
2550 Beverly Blvd., Los Angeles 57, Calif.
Dunkirk 8-6178; and 681 Market Street,
San Francisco 5, Calif. Exbrook 2-3365

Address all correspondence relating
to circulation and editorial to PF
REPORTER, 2201 East 46th Street,
Indianapolis 6, Indiana



Copyright © 1959 by Howard W. Sams & Co., Inc. No part of the PF REPORTER may be reproduced without written permission. No patent liability is assumed with respect to use of information herein. Acceptance of advertising does not in any manner signify the products, policies and services so advertised have been approved, endorsed, or recommended by this magazine.



PF REPORTER®

Including Electronic Servicing

VOLUME 9, No. 7

JULY, 1959

CONTENTS

Previews of New Sets	1
Photos and preliminary data on four '59 TV sets	
Video Speed Servicing	5
Service hints for Philco and Sylvania TV chassis	
Letters to the Editor	12
Shop Talk Milton S. Kiver	20
How FM-tuner AFC circuits work, and how to correct defective operation	
Tips for Techs John A. Comstock	26
TV Tuner Alignment Mike Martynec	28
It isn't easy, but if you must align a tuner, here's the way it's done	
P's and Q's of Transistors Calvin C. Young, Jr.	30
If you're having trouble servicing transistor circuits, this is for you. A portable-radio transistor guide is included	
Repairing Clock Radios	32
3-page picture story on fixing those tricky electro-mechanical combinations	
Servicing New Designs Thomas A. Lesh	36
All about the modern "Gruen" oscillator-reactance tube circuit in new Zenith TV's	
Dollar & Sense Servicing	44
Notes on Test Equipment Les Deane	46
Lab reports on the use of Hickok's Model 6000 tube tester and the Jackson Model 590 VTVM	
Quicker Servicing	50
Unusual TV tube troubles; tool for cutting control shafts; replacing color TV focus control; "Spark Gap" for G-E sets	
Servicing Electronic Organs Jack Beever	54
A general view of electronic designs used and how to run down troubles	
The Troubleshooter	60
Coming Next Month	58
Product Report	70
Free Catalog & Literature Service	72

ABOUT THE COVER

How would you like to replace all the tubes in the instrument shown on this month's cover? Unfortunately for servicemen, organs don't have troubles like this. As for servicing, it's not as difficult as you might think. We can't promise that the setting our cover serviceman finds himself in is typical, however — you'll just have to take your chances on finding an organist as attractive as ours.



ATR ALL-NEW TRUCK Karadio

Perfect for Trucks



Just the thing for Boats

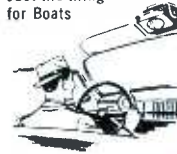

Ideal for Small Cars

(Patent Applied For)

for:

- TRUCKS
- BOATS
- STATION WAGONS
- SMALL IMPORT CARS
- COMPACT U.S. CARS

Illustrating Model TR 1279—12 Volt with Tone Control



ATR

TRUCK Karadio

most versatile truck-auto-boat radio ever designed!

The ATR Karadio is a new compact, self-contained airplane-style radio for trucks, boats, station wagons, small import cars, and compact American cars. This handy unit is perfect for trucks because it is easy and inexpensive to install in the cab roof—and its 6-tube radio with powerful 8-tube performance provides remarkable freedom from engine, static, and road noises. The ATR Karadio's single-unit construction (complete with speaker and optional antenna) is also ideal for boats where it can be roof-mounted. For small import and compact American cars, this economical unit can be easily installed in-dash or under-dash, as desired. Available for 6 or 12 volt battery systems!



The ATR KARADIO is ideal for small import cars or compact American cars! Unit is

completely self-contained—extremely compact! Can be mounted in-dash or under-dash—wherever space permits!

SEE YOUR JOBBOR OR WRITE FACTORY

- "A" Battery Eliminators
- DC-AC Inverters
- Auto Radio Vibrators

ATR

AMERICAN TELEVISION & RADIO CO.

Quality Products Since 1931

SAINT PAUL 1, MINNESOTA, U. S. A.

Letters to the EDITOR

Dear Editor:

Referring to the item in the May *Dollar & Sense Servicing* column, "What a Difference a Word Makes," we have found the words "Technical Services," "Technical Fees," and "Operational Fee" are more readily accepted than the word "labor," preferable in most cases to "service."

The enclosed order form is the result of ten years of experimentation. Three others have preceded it, each different in context and form and each tested for three years. The words "TOTAL FEE C.O.D." at the lower right has greatly reduced our accounts receivable (to less than 2%). To the left of this is "RECEIVED PAYMENT IN FULL by——." Saves writing the word paid, and lets the customer know we expect payment when the work is done.

The *piece de resistance* is the wording in the left-hand column, which tells the customer to make sure the set is working satisfactorily *before our man leaves the house* because we cannot make free re-calls. At first we thought the wording too strong—but the results over the past 12 months have been amazing, resulting in a saving of over \$2,000 as a result of the drop in call-backs, nuisance calls, etc. To top it off, we've lost no customers or their good will (as far as we can tell); in fact, we sense a greater respect toward our operation because our customers understand our policies and are willing to accept our fees.

All our calls are followed up by a thank you "card,"—but not the usual kind. We send them a gift which is *not* thrown away. It is a small needle book which includes a threader. Surprising how many people forget your name, even in a very short period of time—but they remember the needle book.

Other simple things can be done to increase the professional status of men in our business, thereby assuring adequate monetary compensation and respect for our intellect. Our men always wear a white shirt and tie on calls, together with wool trousers. (Plastic blends wrinkle and bag too easily. One service call on your knees and you walk out looking like you're wearing "accordion-pleated" pants.) The collar needn't be buttoned, nor the tie pulled choking tight. Even with the sleeve cuffs turned up to reach inside dusty sets, professional appearance is retained. The results are positively amazing; we rarely have complaints about the \$5.00 fee. Of course, a friendly attitude, proper use of a drop cloth, and a professional manner all help to achieve the total picture.

DON M. DIERS

Milwaukee, Wisc.

You've said enough for all of us, Don. Congratulations on finding and using the right combination to build a successful service business.—Ed.

Dear Editor:

I have just looked through the June edition of PF REPORTER and noticed that the Zenith and RCA circuits in "Video Speed Servicing" have been reversed.

BRIAN J. MAROHNIC

Service Division
Zenith Radio Corp.
Chicago, Ill.

THE EDITOR:

JUNE ISSUE INTERCHANGED SCHEMATICS PAGES 5 AND 6 WITH 7 AND 8. CARD RCA 108-8 INDICATES R18 OPENS FREQUENTLY. SUGGEST IT BE REPLACED WITH FILM-TYPE GLASS 3-WATT UNIT, RCA PART NO. 106042.

E. A. HILDEBRAND

QUALITY CONTROL
RADIO CORP. OF AMERICA
CAMDEN, N. J.

First time we've heard of the special replacement for R18. We, and our readers, thank you for the tip, Mr. Hildebrand.—Ed.

Dear Editor:

Just received my June issue, and was quite confused over *Video Speed Servicing*. What are you trying to do, make me lose the few hairs I have left? In case you don't already know it, the RCA and Zenith schematics have been transposed.

E. J. CUFFE

Chicago, Ill.

Thanks, fellows—we really goofed on this one! Just goes to show that Editors are human (?), too.

If you're saving these sheets, we'll supply a corrected 4-page reprint on request. We apologize to all our readers who have been inconvenienced as a result of this error. Steps have been taken to prevent such a thing from happening again (meaning the Editor gets the axe the next time).—Ed.

Dear Editor:

Several days ago, I called Associate Editor Cal Young (long distance) regarding an intermittent flashing raster on a Philco set. He was able to get out the PHOTOFAC Folder and suggest changing the coupling capacitor from the tuner to the first video-IF grid without any waste of time.

He was right; a new capacitor did the trick, and I want to thank him for his help. I have been servicing TV's for ten years (in electronics full time since 1938) and still find myself up a tree on occasion. Congratulations on having such a fine editorial staff and an excellent magazine.

FRANK L. STEWART

Mt. Dora, Fla.

Glad Cal was able to help you on this, Frank, although we don't advocate that

• Please turn to page 59

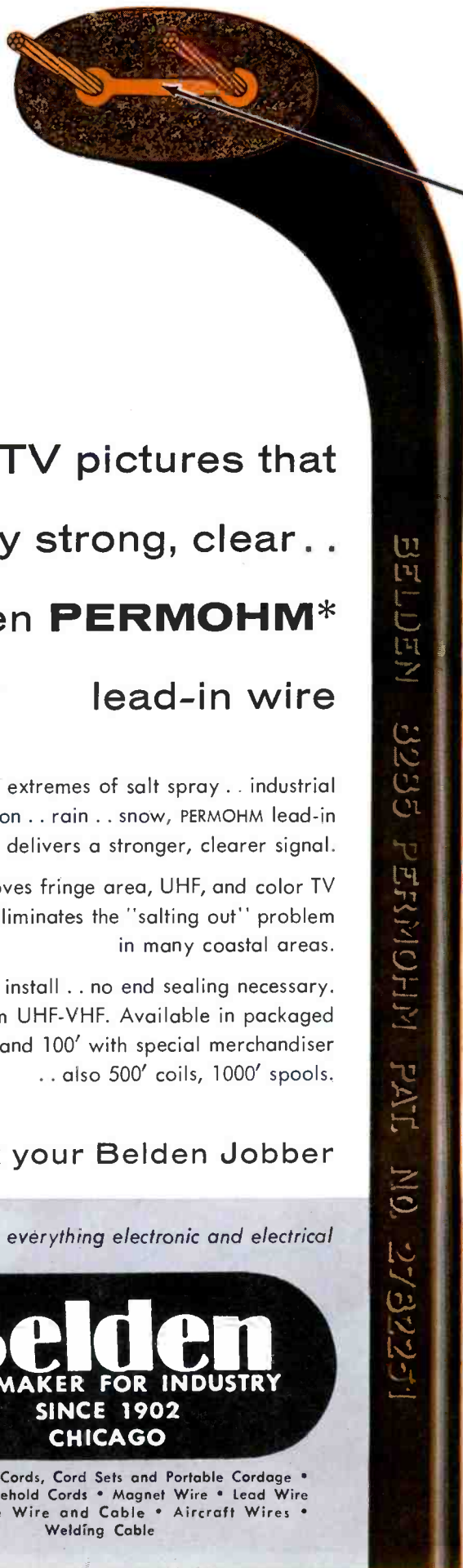

PERMOHM* means constant impedance . . . because its conductors are protected by encapsulation in cellular polyethylene.

for TV pictures that
stay strong, clear . .
NEW Belden PERMOHM*
lead-in wire

In spite of extremes of salt spray . . . industrial contamination . . . rain . . . snow, PERMOHM lead-in wire delivers a stronger, clearer signal.

PERMOHM improves fringe area, UHF, and color TV reception, and eliminates the "salting out" problem in many coastal areas.

PERMOHM is easy to install . . . no end sealing necessary. 300 Ohm UHF-VHF. Available in packaged lengths of 50', 75' and 100' with special merchandiser . . . also 500' coils, 1000' spools.

ask your Belden Jobber

one wire source for everything electronic and electrical



- Power Supply Cords, Cord Sets and Portable Cordage
- Electrical Household Cords • Magnet Wire • Lead Wire
- Automotive Wire and Cable • Aircraft Wires • Welding Cable

*Belden Trademark and Belden Patent . . . U. S. Patent No. 2782251

8-1-9

First time ever...

Coast-to-Coast

HEAR
famous NBC stars
talk about the most
impressive document in
TV servicing history,
about to be announced
to the public.

HEAR
Charles Francis Adams,
John Thompson and
other top industry
figures talk about the new
Raytheon—and *you*.



Your Master of
Ceremonies--
BEN GRAUER,
famous NBC
host.

Your
Raytheon
Distributor
has a few
surprises,
too.

HEAR
top-level executives
from **LOOK, TV GUIDE**,
NBC, talk about
exciting new plans
for *you*.

Closed Circuit Meeting

for TV-Radio Service Dealers!

Ask your
Raytheon Distributor
for time and date.
Don't miss the
biggest event of the
year. It's free!

HEAR
how Raytheon will
saturate the country with
year-round advertising
featuring *your* name,
and something *new* in
TV-radio servicing.

Coming soon—great new profit-making
news from Raytheon. You have a date
with the stars of radio, TV and movies,
as guest of your local Raytheon Distrib-
utor at your nearby NBC radio station.
Famous stars of the exciting *NBC*
weekend spectacular MONITOR will
tell you how to cash in with a dynamic,

ALL NEW PROFIT-BUILDING PROGRAM!

New full-color sound slide film
tells the exciting details

It's a selective deal for leading inde-
pendent service dealers, like you. Don't
miss this outstanding opportunity. For
complete details of this news-packed
Closed Circuit Meeting, check your
Raytheon Distributor for date, time and
place. There's never been anything like
it before!

RAYTHEON

Radio-TV Shop Owner Leo Schweid Says...

**"Components Make or Break
My Reputation..."**

**That's Why I Specify
Mallory Parts"**



"Business experience gained on two continents has taught me there can be no compromise with quality when you're trying to establish a reputation. Mallory established its reputation for quality a long time ago . . . and I know I can depend on Mallory components for TV and radio replacement."

You can enhance your reputation with Mallory silicon rectifiers. Three different models, each designed for specific service applications, fit the most popular television and radio circuits as replacements

for metallic rectifiers. They give far longer life, lower forward voltage drop and reverse leakage current. All three types exceed requirements of military humidity tests:



Type T—for the most economical replacement of selenium rectifiers

End Call-Backs with These Quality Mallory Components



Gems—5 rugged, moistureproof, Mallory "Gem" tubular capacitors in an easy-to-use dispenser that keeps your stock fresh and clean—easy to find—no more kinks in lead wires. Outstanding for service in buffer, bypass or coupling applications.



FP Electrolytics—The Mallory FP—the original 85°C capacitor—now has improved shock-resistant construction and leakproof seal. Its etched cathode construction—standard in all FP's—assures hum-free performance. Famous for high ripple ratings.



Sta-Loc* Controls—New design enables your distributor to custom build, in just 30 seconds, any of over 38,000 combinations—eliminates waiting for out-of-stock controls. You can replace the line switch without unsoldering control connections.

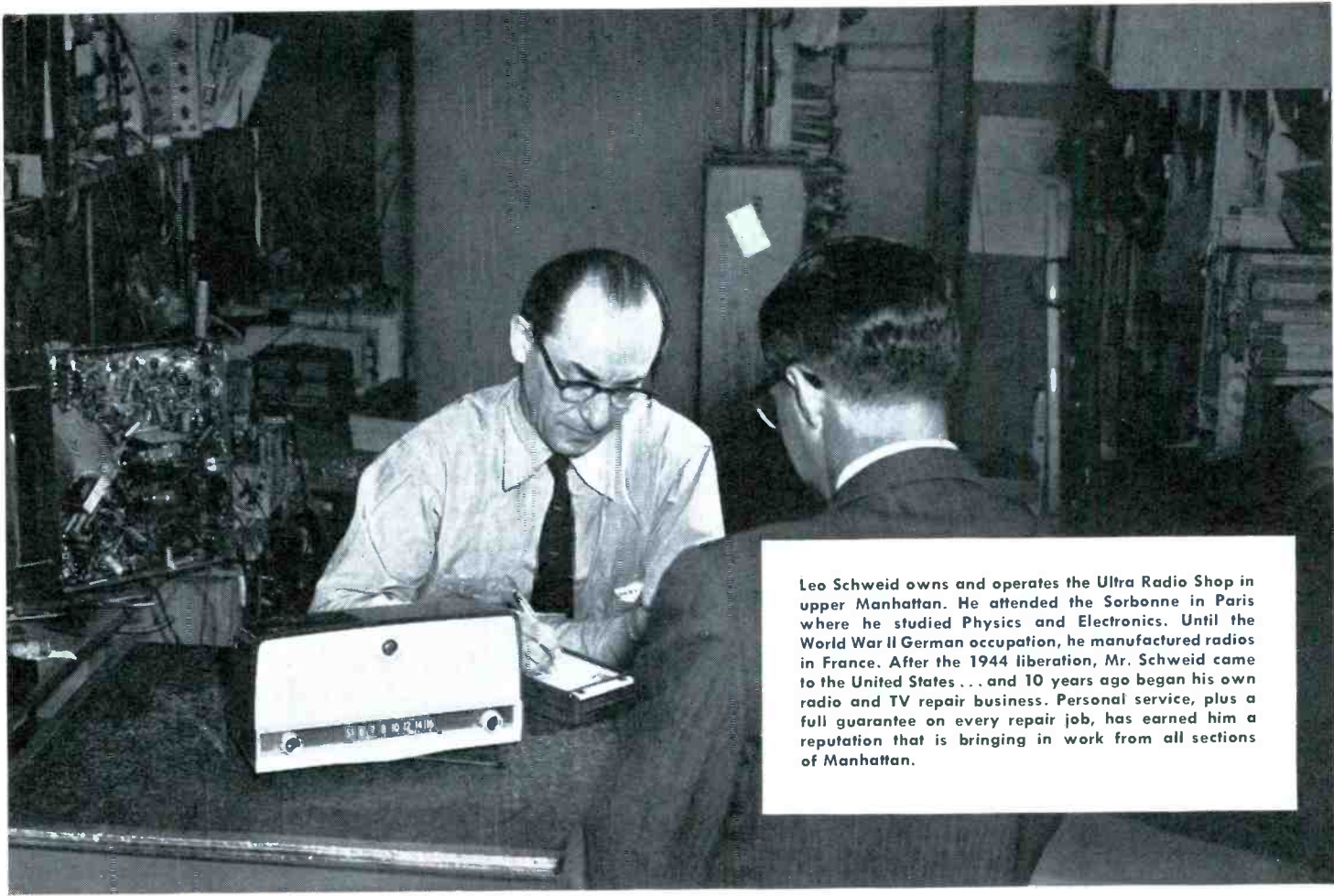

Leo Schweid owns and operates the Ultra Radio Shop in upper Manhattan. He attended the Sorbonne in Paris where he studied Physics and Electronics. Until the World War II German occupation, he manufactured radios in France. After the 1944 liberation, Mr. Schweid came to the United States . . . and 10 years ago began his own radio and TV repair business. Personal service, plus a full guarantee on every repair job, has earned him a reputation that is bringing in work from all sections of Manhattan.



Type P—for plug-in replacement in sets that are already converted



Type E—for the ultimate in reliability and performance

Rectifier conversion kits are also available for economical TV and radio conversion. Whatever components you need for servicing, you get highest quality at sensible prices from Mallory. Why not see your Mallory distributor today.

P. R. MALLORY & CO. Inc.

MALLORY

P. R. MALLORY & CO., Inc., INDIANAPOLIS 6, INDIANA



TC Tubular Electrolytics—Economically priced electrolytic filter capacitors with a reputation for doing an excellent job. They have been proved in performance and are backed by years of Mallory experience. Also special TCX type available for -55°C .



Gold Label[®] Vibrators—On critical auto radio servicing, use the Mallory Gold Label Vibrator. It gives longer, trouble-free service life. Mallory Gold Label Vibrators feature Mallory exclusive buttonless contact design.

[®]Trademark



RMC Discaps[®]—Made by the world's largest producer of ceramic disc capacitors. Long the original equipment standard, are now available for replacement. They come in a handy 3" x 5" file card package.

[®]A registered trademark of Radio Materials Company, a division of P. R. Mallory & Co., Inc.

Estimate the
value of everything
in this picture

... AND WIN

in Westinghouse
Giant Jackpot
contest

A new contest every two weeks . . .

4 Giant Jackpots in all . . .

. . . hundreds of other prizes!

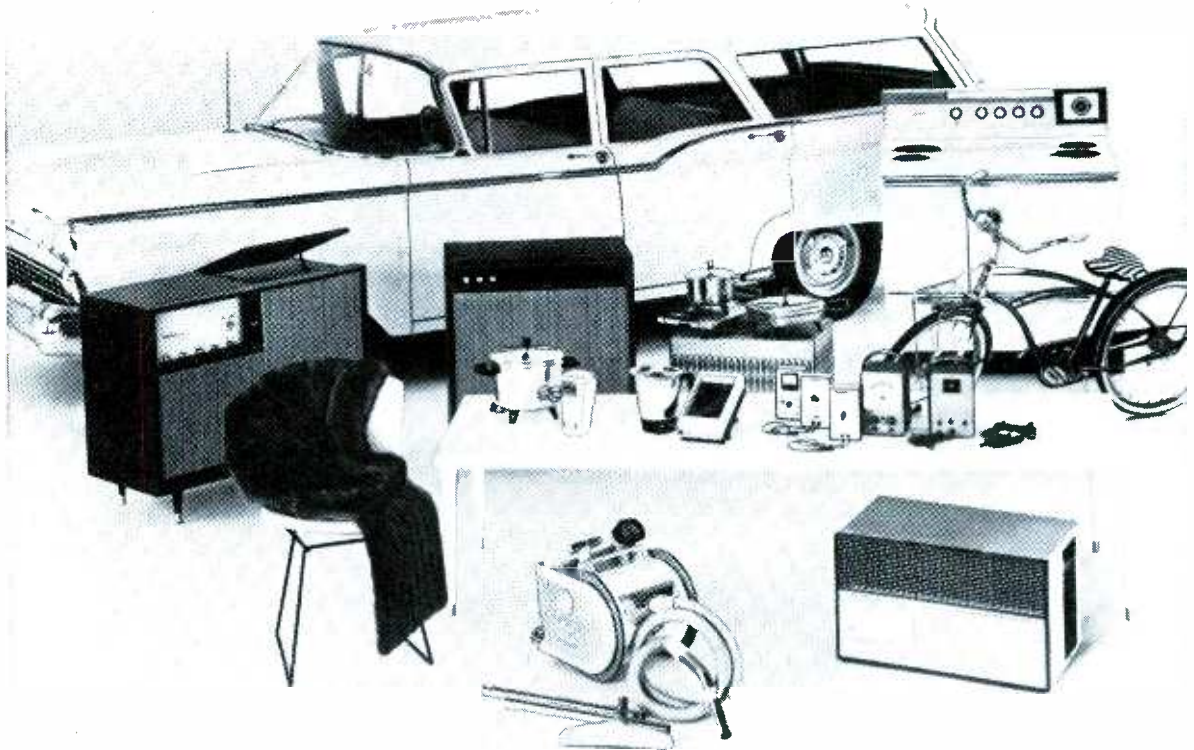

IT ALL!

You can win absolutely everything shown in this picture, simply by estimating its total retail value. Would you say hundreds of dollars? Thousands of dollars? The closest guess will win it all! Enter now! Enter as often as you like!

Never before a contest so easy to enter . . . so easy to win! Four separate contests! Four separate Giant Jackpots! And you can enter all four—try for the Giant Jackpot as often as you like! Hundreds of other valuable prizes if you miss the top award!

Just 3 easy steps to enter . . .

1. Ask your Westinghouse distributor for a supply of official entry forms . . . several for each contest you want to enter.
2. Estimate the total dollars-and-cents retail value (exclusive of local sales and Federal excise taxes) of all the items shown and described in the picture for the contest you are entering. You'll receive an information leaflet with your entry blanks which shows photographs of all four Giant Jackpots.
3. Write your estimate on the Entry Form and mail along with the end panel from a Westinghouse 5-pak tray which reads "Westinghouse Electronic Tubes," or a reasonable facsimile, to: "Jackpot," Westinghouse Electric Corp., Box 365, New York 46, N. Y.

That's all there is to it . . . and just look what you can win! 4 first prizes: "Winner Take All"—everything shown in a Giant Jackpot picture.

4 second prizes: Your choice of Westinghouse Refrigerator, Freezer, Laundromat, Dryer, Two Different Ranges, Room Air Conditioner.

4 third prizes: Your choice of Westinghouse Refrigerator, Freezer, Dryer, Range, Air Conditioner.

48 fourth prizes: Your choice of two Westinghouse Immerse-A-Matic appliances and a control unit.

100 fifth prizes: Your choice of Westinghouse Spoutless Coffee Maker or Portable Mixer.

240 runner-up prizes: Westinghouse Dog-O-Matic Hot Dog Cooker.

FIRST CONTEST STARTS AUGUST 3, 1959! GET ENTRY BLANKS AND OFFICIAL RULES FROM YOUR WESTINGHOUSE DISTRIBUTOR TODAY.



If your distributor does not sell Westinghouse tubes, send his name and address to Westinghouse, Box 284, Elmira, N. Y.

YOU CAN BE SURE...IF IT'S Westinghouse
Electronic Tube Division Elmira, N. Y.

ShopTalk

MILTON S. KIVER

Author of . . .
*How to Understand and Use TV Test Instruments
 and Analyzing and Tracing TV Circuits*

AFC for FM Tuners

A circuit that is being used with increasing frequency in FM tuners (or the FM section of AM-FM tuners) is the automatic frequency control (AFC) circuit. The purpose of this network is to hold the local RF oscillator to the frequency established by the set user. The front-end section of an FM tuner receives signals from 88 to 108 mc, and the local oscillator operates 10.7 kc above the incoming signal. At these frequencies, it is more difficult to stabilize oscillator frequency than it is at AM frequencies in the 550 to 1600 kc band. Oscillator drift, in turn, will quickly tend to distort the sound output of the receiver and make it necessary to frequently retune the front dial. By means of a relatively simple AFC network, this trouble can be avoided.

(AFC is beneficial from the user's point of view because it enables him to achieve and maintain correct tuning at all times. All he has to do is come reasonably close to the desired station and then switch in the AFC network. This immediately shifts the frequency of the local oscillator until the signal

is centered in the pass band of the receiver.

Basic Circuit

The operation of a typical FM-AFC circuit is not difficult to understand, provided the phase relationships in the circuit are kept in mind. A common arrangement is shown in Fig. 1. V1A is the AFC stage and V1B is the FM oscillator. Connection between the two tubes is through the 22-mmf capacitor C2, which in essence places V1A across coil L1. This coil is part of the oscillator tuning circuit, and if V1A can be made to appear as a small variable capacitor, it will serve to alter the frequency generated by the oscillator. This, in effect, is exactly what V1A does; hence, it is known as a reactance tube.

Through the connection of C2, the RF voltage present in the oscillator tuning circuit reaches the plate of V1A. At the same time, RF current from the plate of V1A feeds back to the grid circuit through capacitor C1. The signal path is completed to ground by C3, which is of a value that is essentially a short circuit to RF currents. Insofar as AFC action is concerned, it can be disregarded.

Since the capacitive reactance of C1 is several times greater than the resistance of R1, the current through R1 and C1 will lead the voltage from L1 by a phase which approaches 90°. The voltage developed across R1 is in phase with the current through it, and it is this voltage which acts as the grid signal for V1A. Hence, the phase of the grid signal will lead the phase of the oscillator voltage by 90°.

Next, let us consider the plate current of V1A. It is governed by the grid voltage; thus, the plate current of V1A leads the voltage across L1 by something close to 90°, and V1A appears as a capacitor shunting L1. The value of capacitive reactance afforded by V1A is governed by the amount of plate current flowing and this, in turn, depends upon the V1A bias.

The stage is now set to bring to the grid of V1A a voltage which will reveal when the signal is properly tuned in and when it is not. Such a voltage is obtained from the output of the FM detector (discriminator or ratio detector). When the signal shifts to one side or the other because of local oscillator drift, a greater or lesser bias correction is developed. This voltage, properly filtered to remove the audio variations, and having only a DC value, is fed to the grid of the AFC tube where it varies reactance-tube plate current. Thus, if the oscillator tends to increase its frequency, the capacitance presented by V1A will increase, causing the frequency of the oscillator to drop.

AFC Circuit With DC Amplifier

While the foregoing circuit is ex-
 • Please turn to page 68

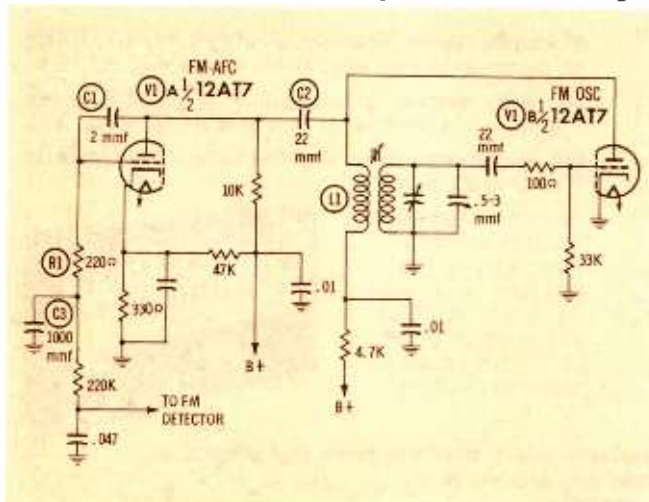

Fig. 1. A popular AFC circuit employed in FM tuners.

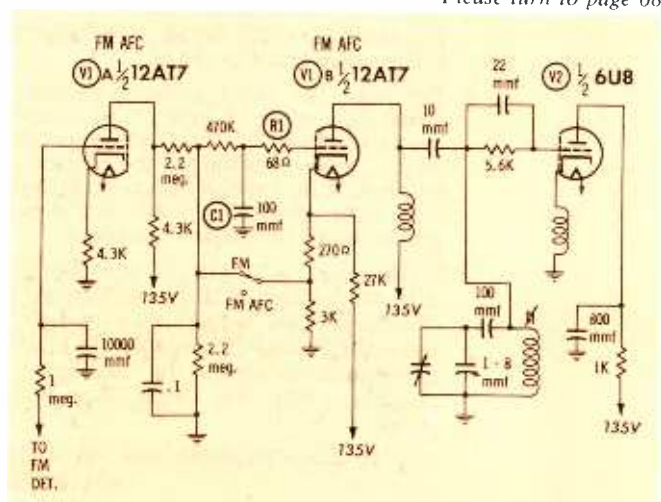
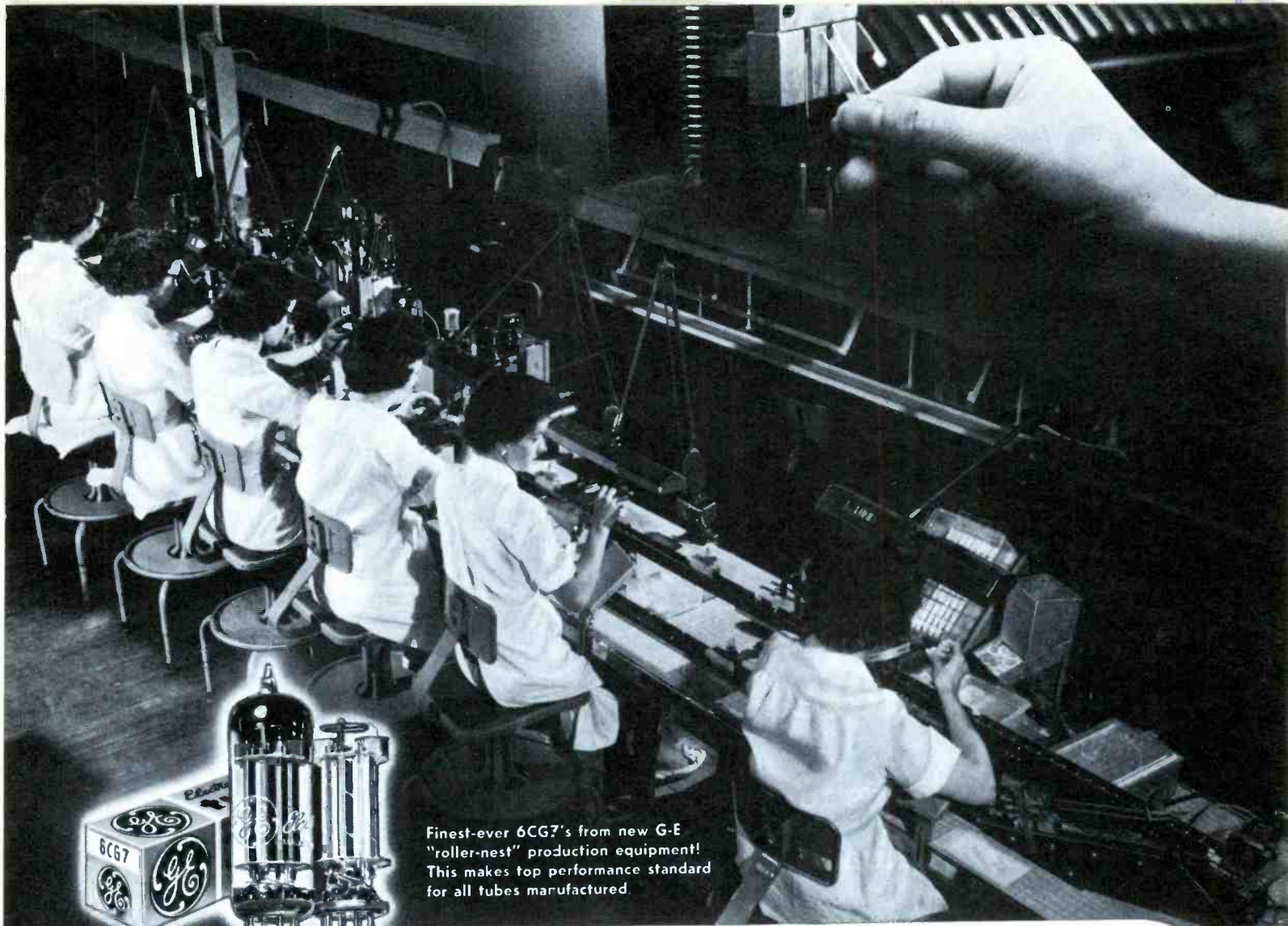

Fig. 2. AFC circuit used in Pilot Model HF-42.



Finest-ever 6CG7's from new G-E "roller-nest" production equipment! This makes top performance standard for all tubes manufactured.

MOST WANTED TUBE NOW BUILT STILL BETTER!

G-E 6CG7—your Service-Designed profit leader—given uniform high quality by new General Electric automated techniques!

The infallibility of machines . . . the craftsmanship of skilled human hands . . . General Electric combines the two in brand-new production equipment for Service-Designed 6CG7's. Tight cages, snug-fitting micas, precision-built mounts—*every tube* now has these, for uniform characteristics and low microphonics. Means minimum circuit adjustments when you install 6CG7's!

Means far less chance, too, of trouble later. This is your big-demand Service-Designed Tube, with waiting TV sockets in the millions. Cut your callbacks 'way down—make your tube sales and profits climb! Order Service-Designed 6CG7's now from your G-E tube distributor! *Distributor Sales, Electronic Components Division, General Electric Company, Owensboro, Kentucky.*

Progress Is Our Most Important Product

GENERAL  **ELECTRIC**

2-111-205

For TV Technicians

RCA PRESENTS

A New Volt-Ohm- Milliammeter

... special ranges for
transistor applications!

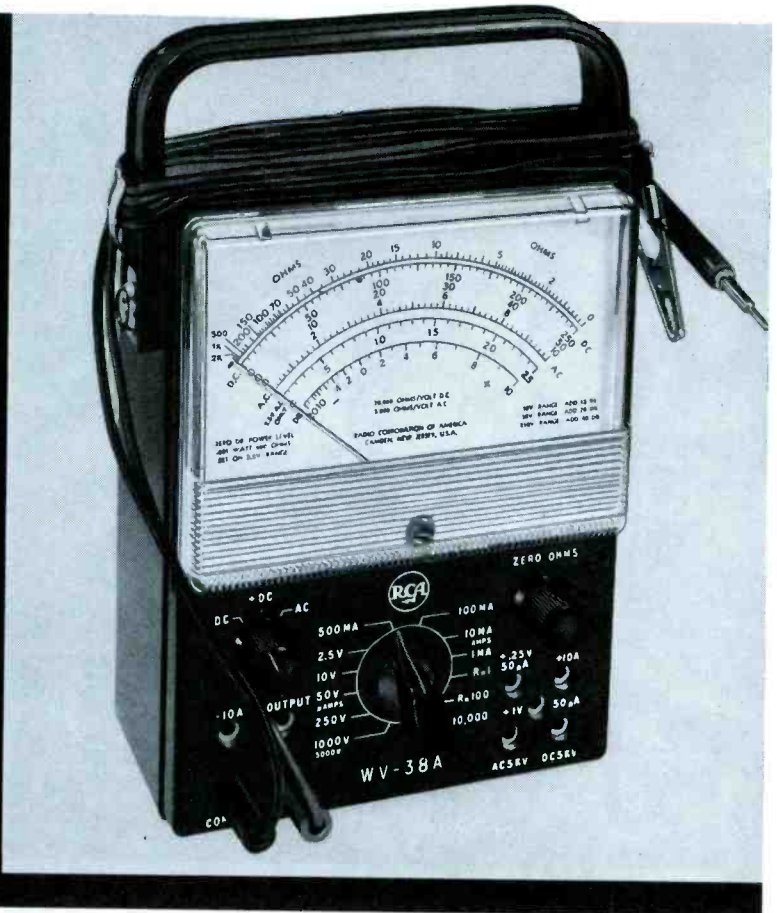

RCA WV-38A
VOM

ONLY \$43⁹⁵*

* Also available as a KIT...
only \$29.95*
Easiest-to-assemble ever!

(includes batteries, cable and probe with slip-on alligator clip, ground lead and clip)

*User Price (Optional)

WV-38A SPECIFICATIONS

Input Resistance	• 20,000 ohms per volt on DC 5,000 ohms per volt on AC
Accuracy (full scale)	• $\pm 3\%$ DC, $\pm 5\%$ AC
Regular Scales	• 2.5, 10, 50, 250, 1000, 5000 volts, AC and DC • 50 μ a, 1, 10, 100, 500 ma, 10 amps (DC) • 250 mv. and 1 volt (dc)
Extra Scales	• 250 mv. and 1 volt (dc)
Frequency Response	• AC—flat from 10 cycles to 50 Kc (usable response at 500 Kc)
Ohms	• 3 ranges: Rx1—(0-2,000 ohms), Rx100 (0-200,000 ohms), Rx10,000 (0-20,000,000 ohms)
Dimensions	• W. 5 $\frac{1}{4}$ " , H. 6 $\frac{7}{8}$ " , D. 3 $\frac{1}{8}$ "

EXCLUSIVE! Extra 1-volt and 0.25-volt (250 mv) dc ranges for servicing transistor equipment!

EXCLUSIVE! New handle clips accommodate probes and test leads for extra carrying convenience!

You'll do a more professional servicing job with this highly accurate, versatile and stable VOM—a world-beater from the world leader in electronics!

Never so many valuable features packed into a VOM!—Ohms-divider network fuse-protected. Easy-to-read scales! Extra-large 5 $\frac{1}{4}$ -inch meter. Polarity reversal switch. Improved frequency response. Full-wave bridge rectifier. Less circuit loading. Standard dbm ranges. PLUS—modern styling—it's an instrument you'll be proud to "show off" in the home or the shop!

See it at your local RCA Test Equipment Distributor!

on the go...

RCA PRESENTS

A New VoltOhmyst

... with additional scales for accurate low-voltage measurement

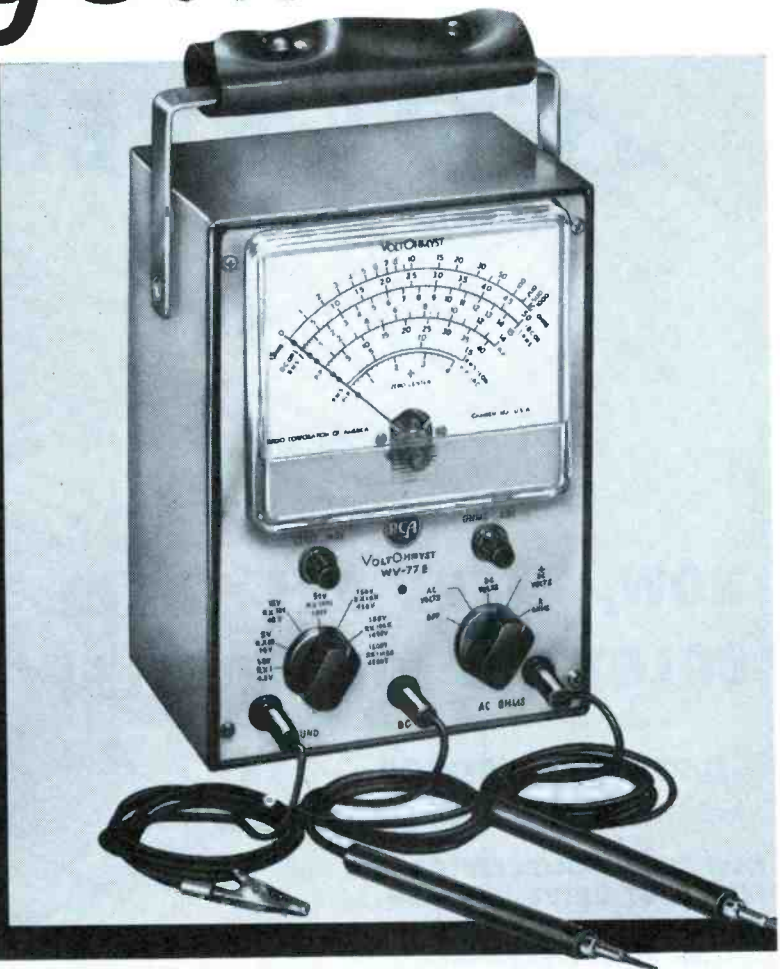

RCA WV-77E VoltOhmyst

ONLY \$49⁹⁵*

(includes test probes and leads, and ground clip and lead)

RCA WV-77E(K) VoltOhmyst Kit only \$29.95*
Easiest-to-assemble ever!
*User Price (Optional)

FREE—New Booklet, "Servicing Is Easy with an RCA VoltOhmyst" offered with the purchase of a WV-77E or WV-77E(K) (\$1.00 value).

SPECIFICATIONS

Measures:

DC Volts—0.02 volt to 1500 volts in 7 overlapping ranges

AC Volts (RMS)—0.1 volt to 1500 volts in 7 overlapping ranges

AC Volts (peak-to-peak)—0.2 volt to 4000 volts in 7 overlapping ranges

Resistance—from 0.2 ohm to 1000 megohms in 7 overlapping ranges. Zero-center indication for discriminator alignment

Accuracy—±3% of full scale on dc ranges; ±5% of full scale on ac ranges

Frequency Response—flat within ±5% from 40 cycles to 5 Mc on the 1.5, 5, and 15-volt rms ranges and the 4, 14 and 40-volt peak-to-peak ranges

DC Input Resistance—standard 11 megohms (1 megohm resistor in probe)

Prove it to yourself! Here's a VTVM you can use almost anywhere—in the home, shop, or factory—combining flexibility, accuracy, and dependability!

Look what you get—ohms-divider network protected by fuse—ultra-slim probes and flexible leads for getting into those tight spots—leads, probes, and power cord can be stored in sleeve attached to handle for increased portability—separate scales for 1½ volts rms and 4 volts peak-to-peak maintain instrument accuracy on low ac measurements—all lettering on front panel acid-etched to last the life of the unit!

The RCA WV-77E VoltOhmyst is available "off-the-shelf" from your local RCA Test Equipment Distributor. See it, try it—bet you buy it!



RADIO CORPORATION OF AMERICA
Electron Tube Division
Harrison, N. J.

Winegard's

GOT EVERYTHING...

NOW, THERE ARE THREE COLOR'CEPTOR MODELS!

SUPER COLOR'CEPTOR MODEL SCL-4

NEW SUPER COLOR'CEPTOR HAS FOLD-OUT DRIVEN ELEMENTS, NEW TYPE BOOM SUPPORT AND 2 ONE PIECE WRAP-AROUND MAST CLAMPS.

Now the powerful new Super Color'Ceptor adds a third dimension to the popular Color'Ceptor series. 14 elements including the patented *electro-lens director system. All channel—black and white and color, completely factory pre-assembled with new type fold-out driven elements. *Bright Gold* Anodized. Model SCL-4 — \$38.95 list.



Winegard
GOLD

THE COLOR'CEPTOR MODEL CL4 — America's Most Copied Antenna. The one antenna consumers know by name. For superior reception, black and white and color — all channels 2-13. 11 elements. *Bright Gold* Anodized. Patented Electro-lens director system. Installs easy — sells fast. Model CL-4. \$29.95 list.



Winegard
GOLD

COLOR'CEPTOR WITH POWER PACK MODEL CL-4X. Most Powerful All Channel Antenna Made. Adds 5 directors and 2 reflectors to regular Color'Ceptor to make most powerful performing antenna on the market. Guaranteed in writing to outperform any all channel antenna made. 18 elements. All channels, 2 to 13. Black and white and color. *Bright Gold* Anodized. Model CL4X — \$44.90 list.



COLOR'CEPTOR ONLY ANTENNA GUARANTEED TO PERFORM TO YOUR CUSTOMER'S SATISFACTION.

Winegard's Gold Bond Guarantee guarantees satisfaction on your customer's home or Winegard refunds the full list price — and you still keep your profit. It's the strongest guarantee in the industry.

WINEGARD ANODIZING — More than a beauty treatment, Winegard Anodizing is the most permanent corrosion-proof finish you can give aluminum. Exclusive Winegard Gold pigment (unlike dyes) is *bright* and *sunfast* — lasts far longer than the usual short-cut finishes. Only Winegard has it!

ADVERTISED MONTH AFTER MONTH IN LIFE!

Write today for complete bulletins — specify models!

the most complete line of antennas for your profit and progress

VHF - UHF - FM

Why stock incomplete lines that don't have step-up sell? Antennas that are short on features short-circuit your cash register! Sell Golden Winegard — full line — best known, most advertised in LIFE, Better Homes & Gardens, Successful Farmer, Sunset, TV Guide.



WINEGARD RESEARCH AND DEVELOPMENT LABORATORY



Continuous experimentation and testing go on in Winegard's ultra-modern electronic laboratory. A few Winegard firsts developed from research are—First Gold anodized antennas, First Factory Pre-Assembled Antennas, First and only Patented Electro-Lens Design, First One Piece Wrap-around Mast Clamp, First Universal Roof Mount, First Transcoupler Yagis and more.



MODEL TC1 — BEST ANTENNA EVER DESIGNED FOR STACKING BECAUSE OF NEW WINEGARD TRANSCOULER FEATURE—A LINEAR TRANSFORMER THAT SWINGS INTO POSITION FOR PERFECT STACKING ASSURES PERFECT 300 OHM MATCH. All channels VHF — use single or stack 2 bars for 100% power increase. Patented Electro-lens director system. Extremely high gain on channels 7 to 13. Bright Gold Anodized. Model TC1 — \$19.95 list.



TRANSCOULER YAGIS — NEW SUPER EFFICIENT TRANSCOULER YAGIS 3, 6, 12 ELEMENT. Absolutely the most efficient cut-to-channel and broad band yagis ever built. Use a three element where a five was used, a six for a ten, and a twelve for really tough reception problems. Unique Transcoupler bars swing into position for perfect 300 ohm match and simplest stacking ever devised. In stacking, 100% of power is delivered from both bays. Bright Gold Anodized, wide spaced design. 42 different models.



TRANS'CEPTOR MODEL 20/20 NEW 40 ELEMENT UHF TRANSCOULER ANTENNA. Super powerful, precision engineered for translator channels 72-83 (800-900 mc). This stacked array incorporates 40 wide spaced elements for maximum signal pick-up. Has combined power of UHF corner reflector and a UHF yagi. Model 20/20 packed two to carton with stacking bars. \$20.60 list . . . single bay \$9.95.



"TURNSTILE" FM ANTENNA MODEL FM3T — NEW FM ANTENNA HAS UNIQUE OFFSET MOUNT. Mounts on same mast as TV antenna. Picks up all directions 100 miles and more. Delivers maximum results all across the FM band of 88-108 mc. 2 bays give 40% power increase, 3 bays 68%, 4 bays 96%. Completely factory pre-assembled. Bright Gold Anodized. Model FM3T — \$11.95 list.

Model FM3A "Turnstile" — has same antenna head as above but includes** universal roof mount, lead-in wire, etc. Complete kit. Model FM3A. \$17.95 list.

**U. S. Pat. 2,891,748.

WINEGARD ENGINEERING FOR "SPECIAL AREA" ANTENNAS. Winegard offers special antennas individually engineered for an area problem. You are invited to take advantage of Winegard's ultra-modern antenna research and testing facilities.

WINEGARD ECONOMY LIST ANTENNAS START AT JUST \$2.44 LIST. Write for complete information on full line of plain aluminum ECONOMY kits and antennas.

Winegard Co.

3009 Scotten

Burlington, Iowa

Buy the Leader
and be one!



Dynamic! NEW ADVANCEMENT IN TV SERVICING

See the Latest,
Most Up-to-Date Method
of Servicing TV Horizontal
Sweep Troubles

The
Pioneer 250
HORIZONTAL SWEEP
QUANTALYST... by

DOSS



Only \$109⁰⁰ net

- ▲ FEATURES NEVER BEFORE OFFERED IN ANY INSTRUMENT
- ▲ TESTS THE ENTIRE SWEEP SYSTEM IN-CIRCUIT (RECEIVER ON)
- ▲ NO NEED FOR CHASSIS REMOVAL
- ▲ SIMPLY PLUG INTO DAMPER AND HORIZONTAL AMP. TUBE SOCKETS

Now BEING SHIPPED
TO YOUR DISTRIBUTOR

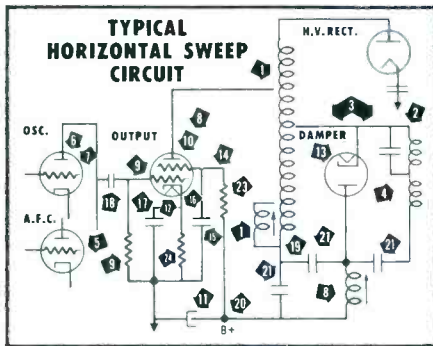

DYNAMIC IN-CIRCUIT TESTS
(RECEIVER ON)

- | | |
|--|--|
| 1. Flyback Transformer (Shorted Turns) | 10. Amplifier Gas Condition (Screen Re-emission) |
| 2. Yoke (Shorted Turns) | 11. Amplifier B+ Ripple |
| 3. Flyback-Yoke Match | 12. Amplifier Heater Voltage |
| 4. Yoke Inductance (mh) | 13. Damper Heater Voltage |
| 5. A.F.C. Sync. Range | 14. Amplifier Screen Voltage |
| 6. Oscillator Frequency (cps) | 15. Amplifier Screen Condenser |
| 7. Oscillator A.C. Output | 16. Amplifier Cathode Voltage |
| 8. Amplifier Cathode Current | 17. Amplifier Cathode Condenser |
| 9. Amplifier Grid Condition | 18. Oscillator Coupling Condenser |
| | 19. Boost Voltage |
| | 20. B+ Voltage |

STATIC CIRCUIT TESTS (RECEIVER OFF)

- | | |
|--------------------------------|------------------------|
| 21. Boost to B+ Resistance | 23. Screen Resistance |
| 22. Boost to Common Resistance | 24. Cathode Resistance |

DOSS

Write DEPT. 7

ELECTRONIC RESEARCH, INC.

820 BALTIMORE • KANSAS CITY 5, MO.

For complete information including FREE Quantalyst Trouble-Shooting Chart—Please request Folder MP2

TIPS for TECHS

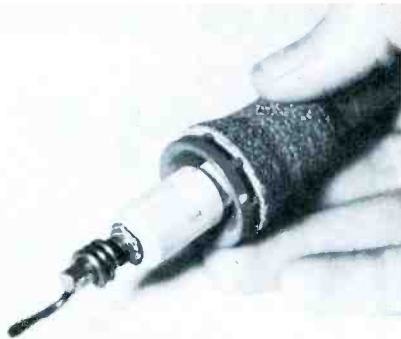

Soldering Tip for Close Work

When you have some close soldering to do but don't have a "needle" soldering tip handy, wrap a short length of solid copper wire as shown. Make sure it fits snugly, bend out one end and tin it as you would any other tip. You'll find this gimmick handy for that once-in-a-while "close-up" soldering job that requires only a little heat. Although the tip doesn't take the place of a regular "needle" tip, it's handy in emergency cases.

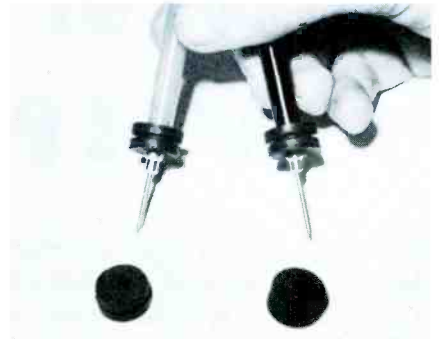

Grommets As Finger Shields

If you tend to let your finger tips come in contact with the metal tips of your voltmeter prods, you realize how easy it is to be shocked. Further, letting your fingers come in contact with the prod tips when making resistance measurements can cause inaccurate meter readings. In effect, your body resistance is placed in parallel with the resistance being measured. You can easily solve both problems by slipping tight-fitting rubber grommets over your test prods as shown.



Are Your Tools Magnetized?

When there's some work to be done around a tape-recorder head, better check your tools for magnetism first. Magnetized tools have been known to induce magnetism into a recorder head and increase the instrument's hum output level. To be on the safe side, check your tools with a compass to see if they are magnetized. If they are, demagnetize them before you start working on the recorder. Tools just naturally pick up magnetism when used around ion traps and other magnet-equipped devices.

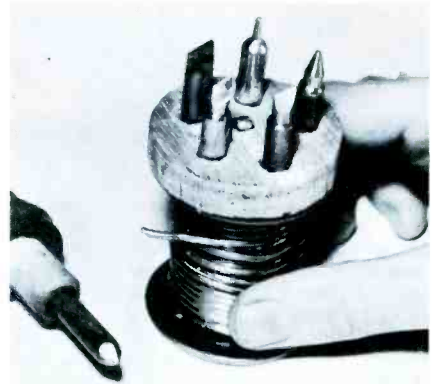

Tip Holder on Solder Spool

A drilled wood disc the size of your soldering spool's flange, fastened to a wood dowel inserted through the core, makes a handy stand for those spare pencil iron tips. By inserting the tips into holes drilled in the disc, (the tips should make a friction-tight fit), they are always in sight for quick selection. Why waste time looking for tips every time you need a certain one, when it only takes a few spare minutes to make this handy tip holder? You can easily transfer it from one spool to the next, too.

SELL WITH CONFIDENCE

Premium-Performance
or Budget-Priced

NATIONAL BRAND PICTURE TUBES



PREMIUM-PERFORMANCE



Silver Vision

- Brighter silver-activated AG-905 screen
- Sharper pin-point focus electron gun
- Nationally advertised brand
- Meets performance specifications of all leading TV set manufacturers

BUDGET-PRICED



PALOMAR

- All-new electron gun
- All-new phosphor screen
- Full 12 months warranty
- Backed by CBS Electronics, a Division of Columbia Broadcasting System, Inc.

For over a year, the combined sales appeal of CBS Silver Vision and CBS Palomar picture tubes has been field-tested on the West Coast. Now this proven sales approach originated by an independent tube manufacturer is available to all independent service-dealers.

Does your customer demand the finest in performance, or is he budget-minded? You can make the sale with CBS

Silver Vision . . . or with CBS Palomar. Either is easy to sell because of top brand prestige. Either stays sold because of top performance in its field.

And their dependable CBS national brand assures you of profit without callbacks. Play safe. Sell premium-performance CBS Silver Vision or budget-priced CBS Palomar with confidence.

THE CBS FAMILY • CBS ELECTRONICS • CBS INTERNATIONAL • CBS TELEVISION NETWORK • CBS LABORATORIES • CBS NEWS • CBS RADIO • CBS TELEVISION STATIONS • COLUMBIA RECORDS • LEADERS IN ELECTRONIC COMMUNICATIONS

ELECTRON TUBES



SEMICONDUCTORS

CBS ELECTRONICS formerly CBS-HYTRON
Danvers, Massachusetts
A Division of Columbia Broadcasting System, Inc.

TV TUNER alignment

How to make sure your customer's sets aren't suffering from front-end troubles

by Mike Martynec

Very often a serviceman is confronted with a problem which is easy to ignore. After repairing the cause of the original complaint, he may notice that the picture on one or more channels is snowy or contains tunable ghosts, symptoms that are not characteristic of the receiver or the area. After checking and rejecting the antenna system, he is prone to contribute the difficulty to an aging receiver or to atmospheric conditions, either because he doesn't want to tackle the problem or he doesn't know how. In most cases of this type the trouble is due to a defect in the tuner, which can and should be remedied. If replacing tuner tubes, cleaning contacts, and retensioning and relubricating contacts doesn't restore normal operation, the chassis should be pulled for a complete tuner checkup.

Checking the tuner involves two distinct steps. The preliminary step will include visual and ohmmeter checks of all resistors. All resistors found to be off value should be replaced. The final check requires alignment-type test equipment and technical service data.

Most television receivers are equipped with one of three different type tuners. The old type tuner is the pentode, using a 6AG5, 6BC5,

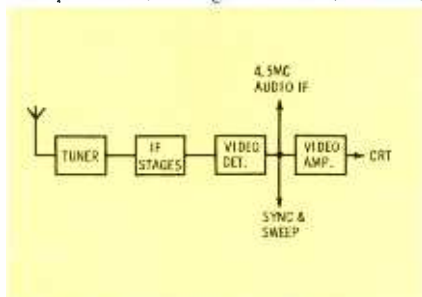

Fig. 2. Block diagram showing relation between tuner and rest of receiver.

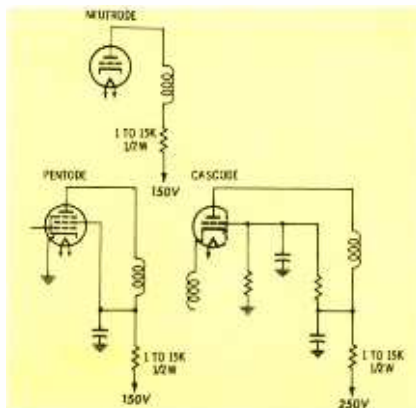

Fig. 1. B+ decoupling networks in pentode, cascode, and neutrode circuits.

or 6CB6 tube as the RF amplifier. Newer types are the cascode, using the 6BQ7, 6BK7, or 6BZ7, and the neutrode using the 6BN4 as RF amplifier. (Series-string filament equivalents are used in many later-model sets.) In all three cases (due to close spacing of electrodes), these tubes are prone to shorts and are the most frequent cause of trouble.

When the plate or screen electrodes short in the pentode type tuner, the B+ decoupling resistor burns and affects the tube's operating voltages. This causes frequency discrimination, and the result is usually poor reception (snow) on the high channels.

In the cascode type tuner, channels 2 through 6 suffer when the RF plate, grid or cathode shorts to an adjacent element. Neutrode tuners are affected by a shorted RF tube in much the same way.

Fig. 1 shows typical B+ feed lines to the various types of RF circuits. The tuner may be opened for a visual inspection either by removing the drum or the side covers. Generally, defective resistors will be located in the B+ feed line (Fig.

1), and it will be fairly obvious which resistor or resistors need replacing. New components should be physically located exactly as the originals were to avoid troublesome alignment problems.

Check tuner tubes carefully for gas or shorts. Preheat and check them at normal operating temperature. A trick of the trade relative to this preheating is to set the tube tester to the next higher heater voltage. For example, the 6BQ7 heater is rated for 6.3 volts; testing it at 7 volts will speed up the process of testing for shorts and gas.

Following the replacement of defective tubes and components, a considerable improvement should be noticed. In many cases, the tuner will have been restored to satisfactory operation. However, the job won't be complete until tuner alignment has been checked and touched up as required.

Your next step, then, will be to check tuner response and make alignment adjustments as required. Before going into the actual tuner alignment, let's go over normal operation procedures and try to understand how a tuner functions.

The tuner's location in the receiver is shown in the block diagram of Fig. 2. Notice in particular that

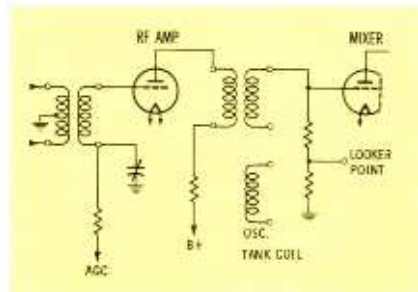

Fig. 3. Simplified RF, mixer and oscillator tuned circuits in turret tuner.

P's and Q's

OF TRANSISTORS

by Calvin C. Young Jr.

A coverage that needs little beyond a knowledge of Ohm's law to understand.

That transistors are different from vacuum tubes cannot be denied. In the field of servicing, this difference is centered around the use of *signal currents* (transistor circuits) rather than *signal voltages* (tube circuits). If the serviceman will accept the fact that transistors provide gain and operate in a mode similar to vacuum tubes, a good portion of transistor theory can be ignored. Most transistor "bugaboos" can be eliminated by the application of a little knowledge and common sense.

It is the intent of this article to present the theory that cannot be ignored, and to do it in as practical a manner as possible. To this end, all theory is given from a servicing perspective, confined to how a circuit works rather than what happens within the transistor.

Biasing

The first thing that must be understood about transistors is the biasing arrangement. There are two junctions in a triode transistor—two NP junctions in a NPN type and two PN junctions in a PNP type. This is illustrated in Fig. 1. Notice the "potential hill," represented by the small battery symbol in dotted lines, across each junction. This potential hill exists due to the presence of positively charged atoms in

the N material and negatively charged atoms in the P material in the immediate area of the junction. The potential difference across the junction is usually about .1 volt. In order for current to flow through a PN or NP junction, the potential hill must be counterbalanced by an external battery or voltage source as shown in Fig. 2. This is forward bias. To prevent an applied signal from causing current to flow across a transistor junction, reverse bias (battery connected to aid the potential hill) is used as shown in Fig. 3. Now that we know how to forward or reverse bias a transistor junction, let's see how this is applied to the transistor circuits used in radios. The transistor circuit used almost universally is the common-emitter arrangement, which compares to the common-cathode configuration used for most vacuum-tube circuits. When the common-emitter hookup is employed, the following statements apply:

1. For PNP transistors, the base-emitter junction is forward biased by making the emitter positive with respect to the base.
2. For NPN transistors, the base-emitter junction is forward biased by making the emitter negative with respect to the base.
3. The base-emitter junction is al-

ways forward biased in an amplifier circuit.

4. For PNP transistors, the collector is always negative with respect to the emitter.
5. For NPN transistors, the collector is always positive with respect to the emitter.
6. When the input signal is applied to the base, input current flows between base and emitter and output current flows between collector and emitter.
7. Output signal current is always greater than input signal current.

Now that we have established the various conditions for common-emitter amplifier stages, let's talk about the schematic symbols for a transistor. Fig. 4 shows the symbols for both NPN and PNP transistors. In either case, the base corresponds to the grid of a tube, the emitter the cathode, and the collector the anode. Most schematics of transistorized devices will show the transistor positioned with the emitter down; remembering that the emitter corresponds to a tube cathode will help you to identify the other elements. Notice also in Fig. 4 that the arrow points toward the base in a PNP unit and away from the base in a NPN type. It is convenient to remember that collector-emitter circuit current flows

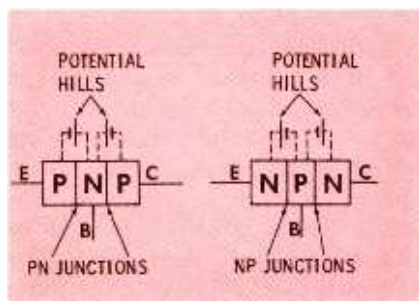

Fig. 1. Examples showing the potential hills in NPN and PNP transistors.

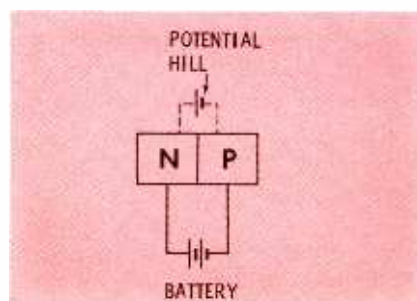

Fig. 2. Basic drawing which shows how a transistor junction is forward biased.

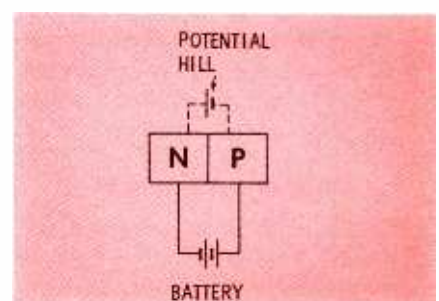

Fig. 3. Basic drawing which shows how a transistor junction is reverse biased.

in the direction opposite to that indicated by the arrow. This point will be most helpful when trying to determine whether the voltage across either the collector or emitter load resistor should increase or decrease with an increase of signal.

Voltage Relationships

The next important step along the road of transistor servicing is to learn the relationship of voltages applied to the base, emitter and collector elements of a transistor. The several examples in Fig. 5 were taken from published schematics of transistor radio receivers. In every instance, notice that the bias considerations mentioned earlier are maintained. For instance, having voltages of -0.9 and -0.8 on base and emitter in a PNP transistor, with -8 volts on the collector, achieves the same net operating conditions as having 7.5 and 7.6 volts on the base and collector of the same PNP unit with $.4$ volts on the collector. In either case, the collector and base are both negative with respect to the emitter. This is further demonstrated in Fig. 6.

Effects of Open Conditions

Knowledge of correct voltage relationships between the various transistor elements can be put to use when there is an open condition in either a circuit component or a lead inside the transistor.

Should the base lead open, the relative voltages would change as shown in Fig. 7. Notice that in the case of the NPN transistor, the emitter voltage goes to zero while the collector rises to the value of the DC supply. This happens because the open base lead removes the base-emitter forward bias and the transistor no longer conducts. In the case of the PNP unit, a little different situation exists. This time

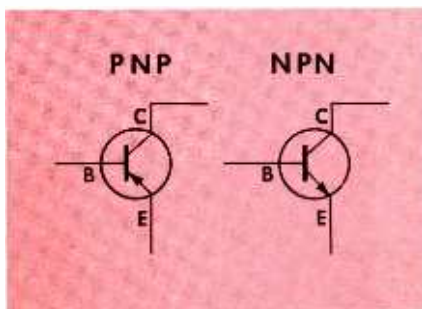

Fig. 4. Schematic diagrams showing the symbols for PNP and NPN transistors.

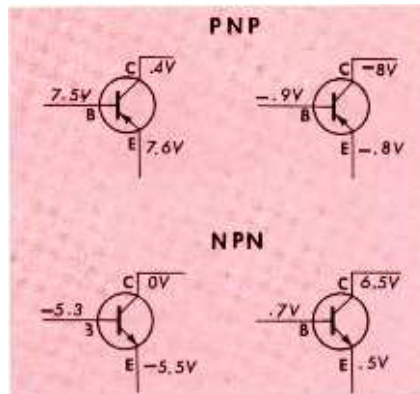

Fig. 5. Examples of various voltages used for different transistor types.

the base voltage remains fairly constant because of the voltage divider network, but the emitter voltage rises to the value of the DC supply and collector voltage falls to zero.

An open base-circuit component, as shown in Fig. 8, would cause the indicated voltage changes. Base-emitter bias is removed, and the transistor ceases to conduct. The emitter voltage then rises to the value of the DC supply and the collector falls to zero volts. The floating base element assumes the same voltage level as the emitter because of the low internal resistance between these elements; however, the actual voltage measured at the base will depend on the

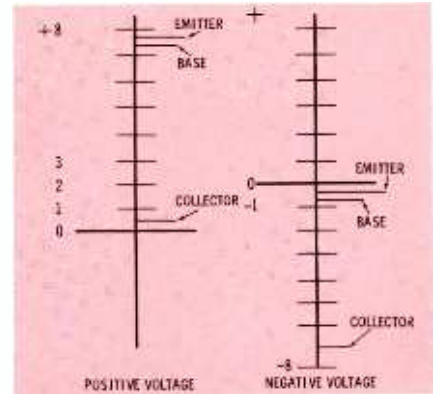

Fig. 6. Graphical representation showing relationship of transistor voltages.

impedance of the meter used for the measurement. A VTVM should indicate about 9 volts.

In the case of the NPN unit in Fig. 8, an open base circuit component removes the base-emitter bias and also disconnects the base-emitter circuit from the DC supply. This causes both base and emitter to fall to zero volts while the collector climbs to the value of its DC supply voltage.

An open emitter circuit would result in the voltage changes indicated in Fig. 9. The base voltage in the PNP circuit would remain fairly steady because of the voltage divider network. The floating emit-

• Please turn to page 61

Cross-Reference Chart of Radio Types

MANUFACTURER	RF	CONVERTER	IF	AUDIO DRIVER	AUDIO OUTPUT
AMPEREX	†OC-170	†OC-170	†OC-170	†OC-71 †2N280	†OC-76 †2N284
CBS		‡2N439 †2N411	‡2N438 ‡2N439	†2N180	†2N180
CLEVITE					†2N257▲ †CTP1117▲
GE	‡2N293 †2N135	‡2N168A †2N136	‡2N293 †2N135	†2N188A ‡2N169A	†2N241A ‡2N292
GENERAL TRANSISTOR	†2N-520 ‡GT-792-R	†2N520 ‡GT-792R	†2N520 ‡GT-792R	†GT-109 ‡GT-948R	†GT-109 ‡GT-948R
MOTOROLA	†2N1107	†2N411 †2N1108	†2N1110 †2N1111	†2N238 †2N573▲	†2N185 †2N176▲
MULLARD					†OC72
PHILCO	†2N344*	†T-1033*	†T 1233* †T 1232*	†T 1001	†T 1005
RCA	†2N247 †2N410	†2N247 †2N140	†2N409-410 †2N139	†2N406 ‡2N35	†2N109
RAYTHEON	†2N416 †2N417	†2N486 †2N485	†2N483 †2N482	†2N362 †2N363	†2N631 †2N632
SPRAGUE	†2N344*	†2N344*	†2N344*		
SYLVANIA	†2N544 ‡2N94A	‡2N212 †2N140	‡2N94 †2N409-410	†2N406 ‡2N35	†2N241A ‡2N214
TEXAS INSTRUMENTS	†2N1107	†2N252 ‡2N172	†2N1110 ‡2N253	†2N238	†2N185
TUNG-SOL	†2N413	†2N414	†2N413	†2N63	†2N382 †2N383
WESTINGHOUSE	†2N616 †2N617	†2N617	†2N615	†2N403	†2N59 †2N60
WORKMAN	†WTV-BA6 †WTV-BA6A	†WTV-BE6 †WTV-BE6A	†WTV-BA6 †WTV-BA6A	†WTV-20MG †WTV-30MG	†WTV-B5 †WTV-B5A

Notes: †PNP types *Surface-Barrier type. May be used to replace PNP types but not vice-versa.
‡NPN types ▲Auto-Radio power output type

Repairing

CLOCK RADIOS

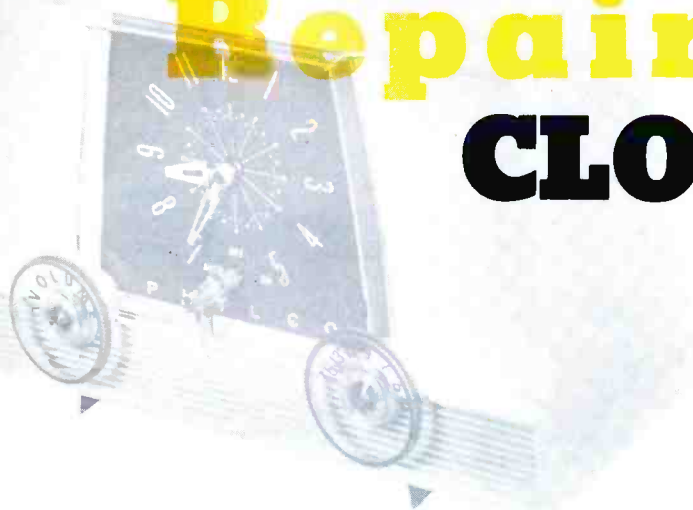

If you're the average serviceman, you've already been exposed to some of the problems peculiar to clock radios. If not, the fact that over two million of these units were produced during 1958 alone should certainly increase your chances. The biggest problems, of course, involve the clock mechanisms themselves. Here are a few servicing tips to help you over the rough spots.

Electrical Circuit

From this simple diagram, you can see that the motor winding of the clock is permanently connected across the power line, and as long as the power cord is plugged into an AC outlet, the clock itself should run continuously—regardless of switch or control settings on the radio. Note that one side of the AC line connects to the radio through a separate timer switch, and power is applied only when this switch is closed. Thus, one electrical switch performs the manual and automatic off-on operation of the radio.

The timer switch is actuated by a cam or lever, which is mechanically controlled by the clock movement. With the clock adjusted to turn the radio on, a quick voltage measurement should tell you if the electrical circuit is functioning.

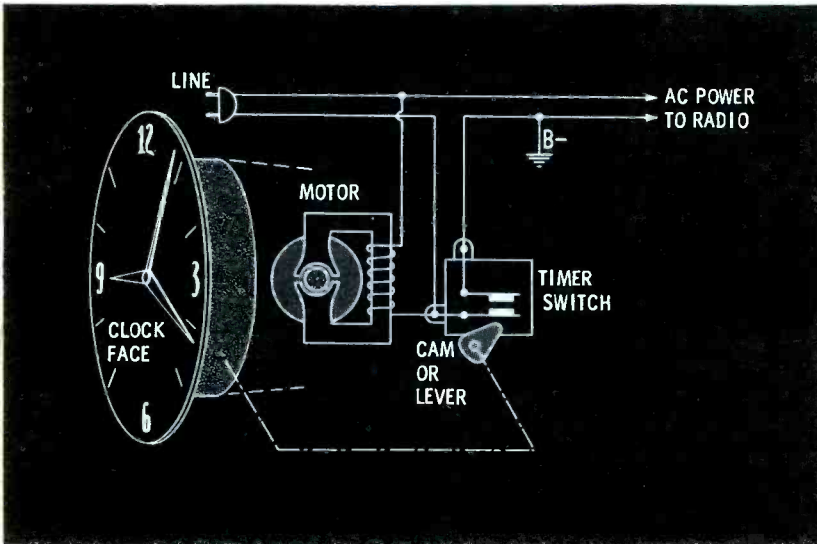

Identification

Determining the clock's manufacturer and model number plays an important part in your service approach, as well as in the procurement of parts for the unit.

Referring to the photos, you'll find that Telechron clocks always have the model number stamped in ink across the bottom of a gummed label, which in turn is placed on the back of the faceplate. Westclox, on the other hand, stamps their model numbers right in the metal of the faceplate. Sessions also uses a metal stamp, but generally mark the clocks on the back mounting plate, as shown.

Warranty work, replacement parts, and general service for the clocks are not usually handled by the maker of the radio, but by independent organizations authorized by the clock manufacturer. When requesting parts from these suppliers, try to give the clock model number, or send in the defective part itself. Control knobs and glass crystals, however, are usually classed as radio parts, and can be obtained from your radio-TV parts distributor. In a few cases, certain faceplates and clock hands must also be obtained in this manner.

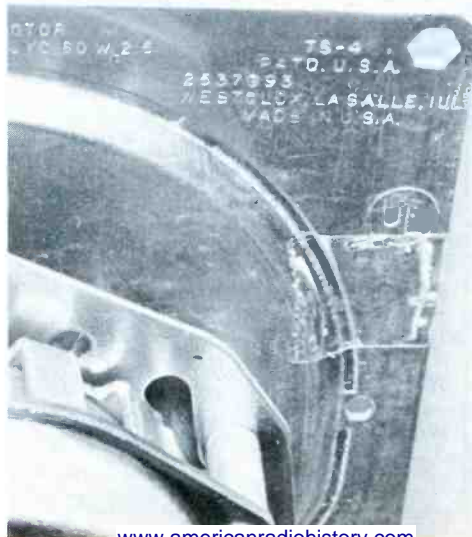

Adjustments

Although you'll find few adjustments on the clock assemblies, you may occasionally run into a jammed mechanism or buzzer that isn't working. With a simple adjustment, you can often put things right again. If the owner has turned one of the knobs too far, for example, some part of the tracking mechanism may leave a groove or skip out of a pivot point. This can be corrected by first loosening the mounting and then slipping the part back into position.

Buzzer systems usually consist of an arm or reed positioned close to the magnetic field of the motor winding, and a buzzer-damper assembly.

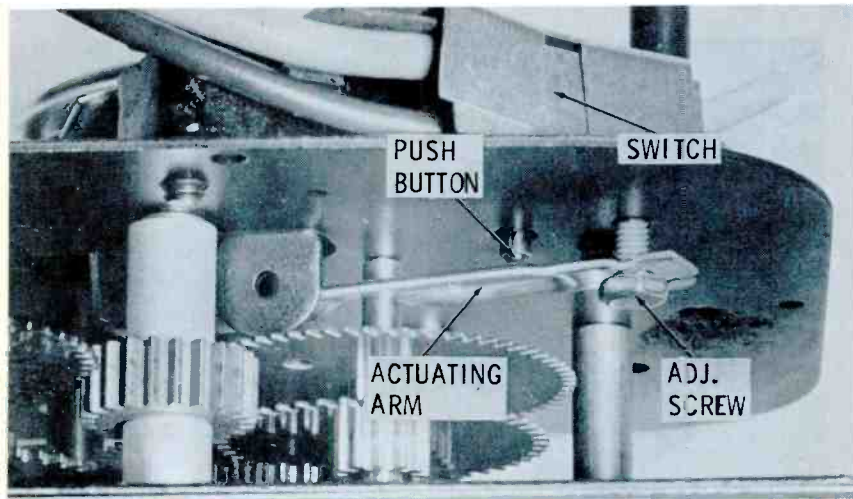
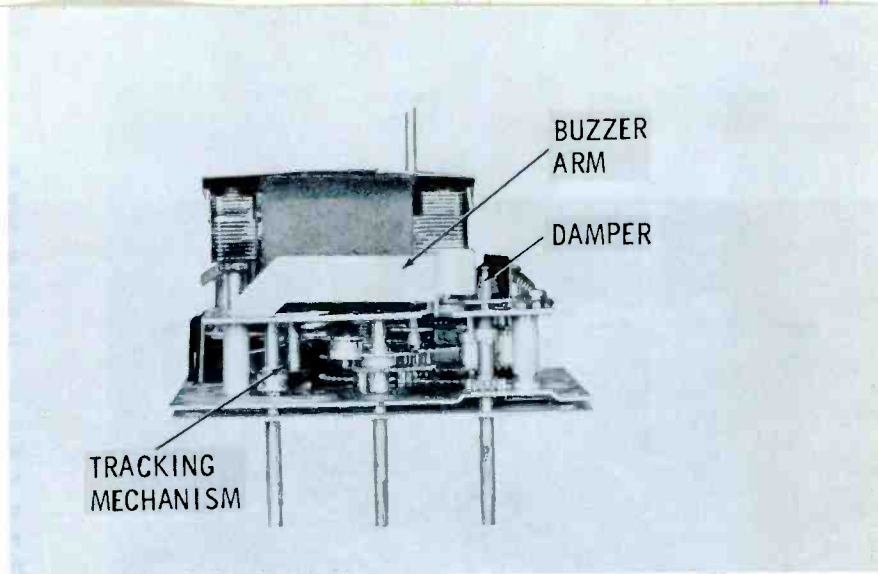

The reed is automatically moved into vibrating position when the damper is released. This action is accomplished by levers or trips controlled by the clock mechanism itself. If the buzzer arm won't vibrate or produce the proper tone, you can adjust it by bending the arm away from or toward the damper assembly.

The adjustment screw pointed out in the photograph regulates the point at which the actuating arm will open and close the timer switch in a Sessions unit. If the arm is bent, or the adjustment screw is too far out, the push button will not close the switch and the radio will not come on when it should.

Switch Troubles

If power is not automatically applied to the radio when it should be, you may have burnt or broken contacts in the timer switch. In many cases, these switches can be replaced easily; however, the front plates of some clocks must be removed first. Since these plates are usually riveted on, it is recommended that you send the clock to one of the authorized service stations, which are better equipped to handle this sort of work. In the Sessions example shown, the switch is one complete unit, and can

be replaced by merely removing the cover and two mounting screws. In the Westclox example, the switch is operated by a separate fibre arm. The corners of this actuating arm may become worn and cause the switch to function improperly. To replace the arm, remove the switch by taking out two mounting screws (see photo) and pulling the switch up and off the arm. When replacing a switch in this type of clock, it's also a good idea to put in a new actuating arm whether or not it looks worn.

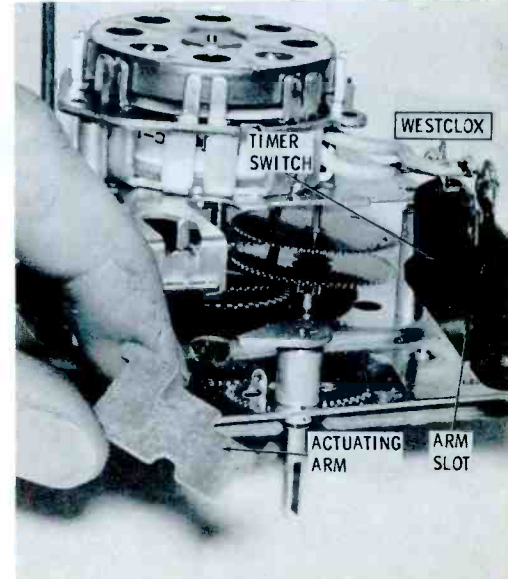
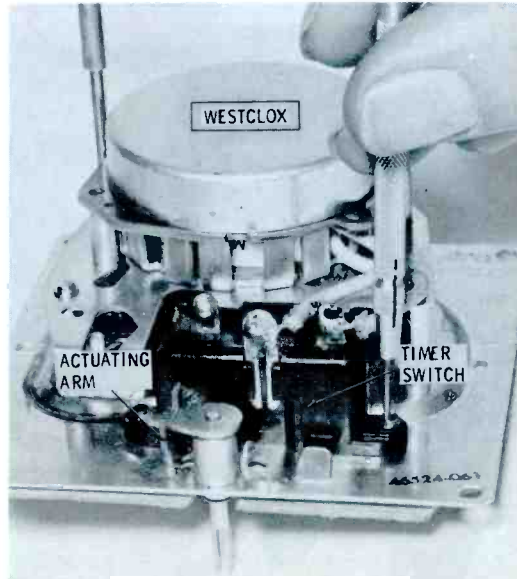
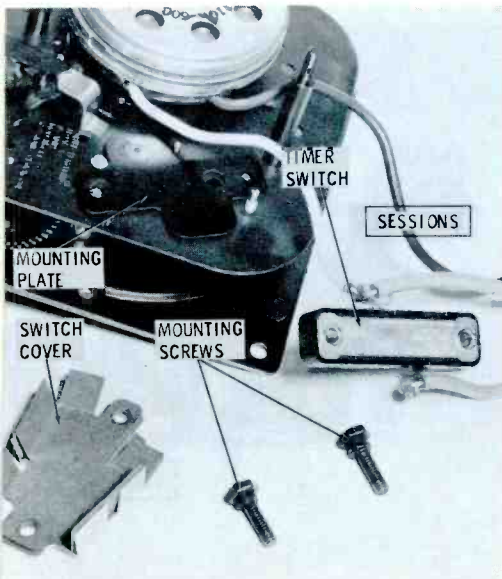

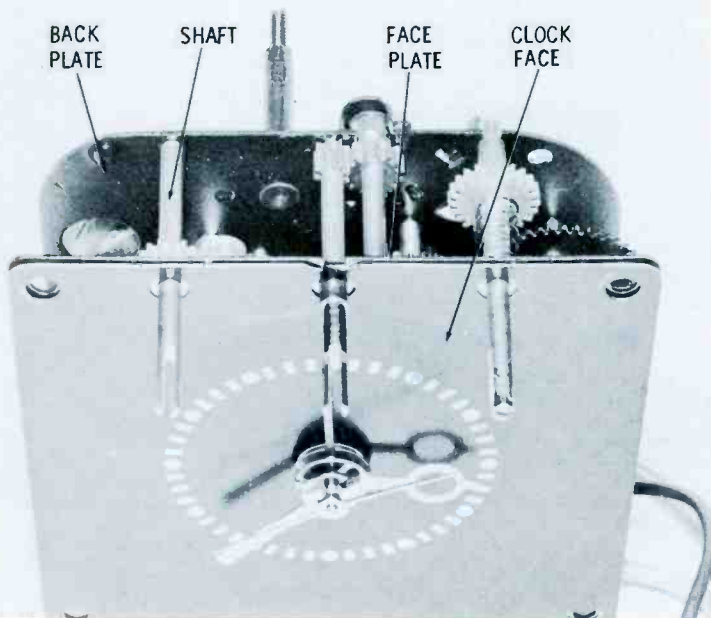

Shaft Replacement

Broken control shafts frequently cause trouble in clock radios, and replacement is not easy. The shafts usually protrude through the front faceplate and are supported by a guide hole or slot on the back mounting plate. To replace such a shaft requires that the clock face and faceplate be entirely removed. This becomes a little involved because the faceplate is most generally "staked" or riveted on. In the majority of cases, you'll find it hardly worth the time and effort involved.

Servicemen have been known to bend the back mounting plate enough to free the shaft, but this practice usually throws the clock movement out of balance and causes a gear or other mechanical part to wear excessively. Such a repair may last for awhile, but permanent damage usually results. Fortunately, at least two companies supply kits of slip-on shafts that make it possible to repair the broken unit without removing the chassis from the cabinet.

Incidentally, if an instrument is sent in for repair, a separate charge of \$2 to \$3 is generally made if the clock unit has not been removed from the radio.

Coil Replacement

You can usually detect a bad motor winding or coil by making a simple DC resistance check. These motor windings generally measure from 700 to 1200 ohms. If a coil becomes defective in a Westclox or Sessions unit, you'll have to replace the entire motor. In a Telechron, however, you may choose to replace either the complete field assembly (which includes the core), or merely the coil itself. In older models, this latter operation was no problem, but in newer units, you'll find the core fastened together by rivets. One rivet must be removed before the winding can be replaced. A small nut and bolt may be used in lieu of the rivet when reassembling the core. It usually pays to make this particular repair yourself, for the part seldom costs more than \$1.50.

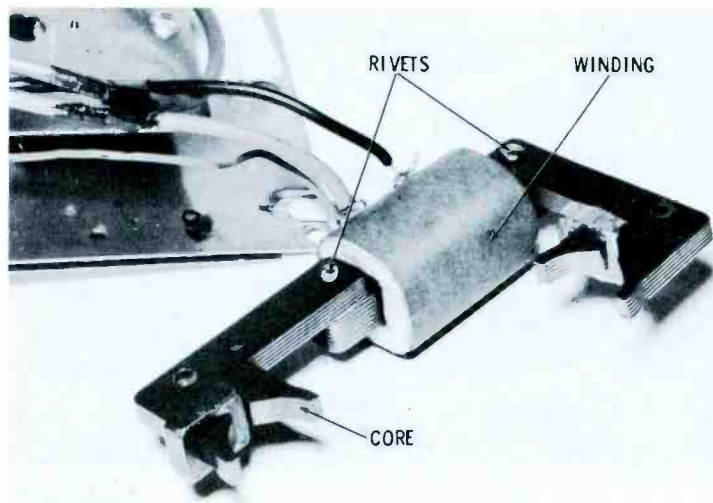

Motor Replacement

Should the clock motor fail, due to an open winding or other cause, you'll find that these units can be replaced easily, usually for less than \$3.00. A Westclox motor, for example, is one complete unit that may be removed by taking out the small screws in the two mounting studs. On the newer Sessions clocks, the entire motor is removed by turning it in a counterclockwise direction until the three

studs are free from the elongated holes in its mounting plate.

Telechron clock motors, on the other hand, are made up of an open core-and-winding assembly which drives a separate rotor unit. The rotor unit itself is replaceable by removing two screws from the core assembly and lifting the rotor up and out of the movement.

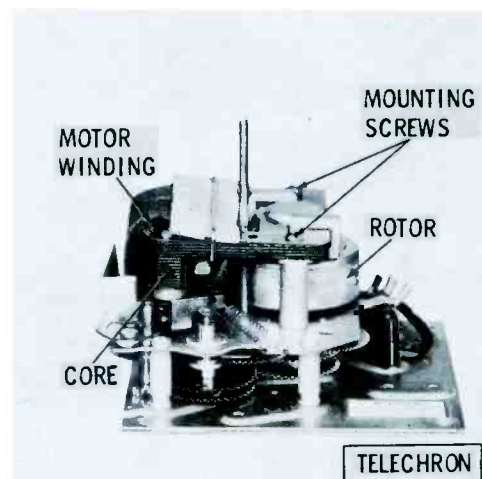
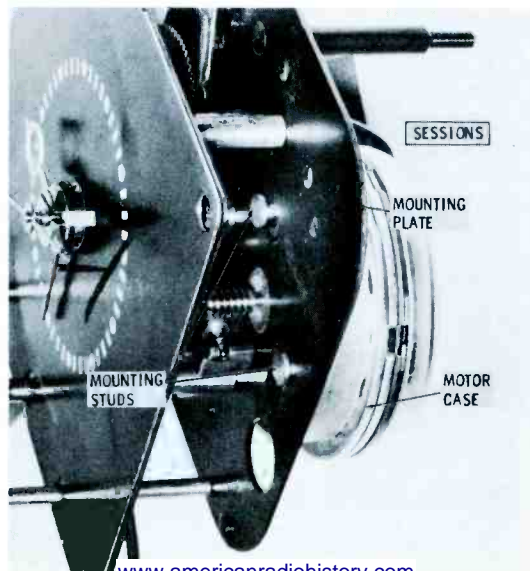
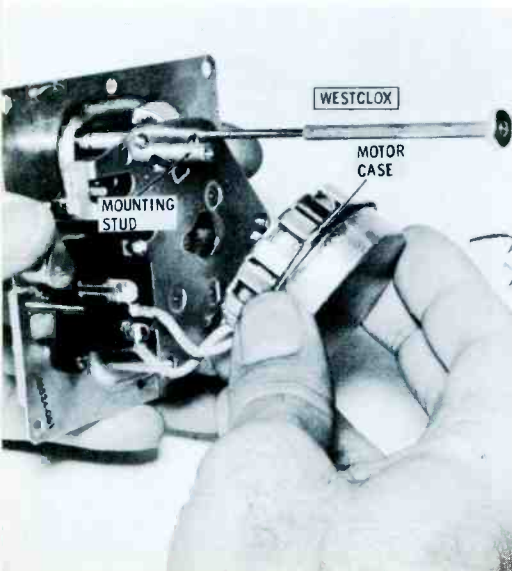

Use Delco Radio Service Parts!

2N278—Highest power transistor used in auto radios.



SPEAKERS



IRON CORES



RESISTORS



CAPACITORS



CONTROLS



TUBES

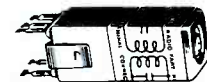

COILS



VIBRATORS

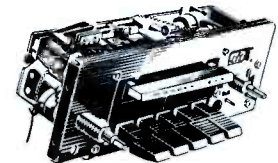

TUNER PARTS

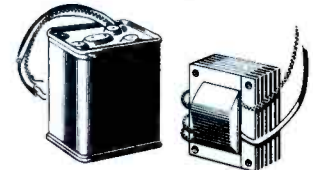

TRANSFORMERS

Your Delco Radio Electronic Parts Distributor carries the complete line, giving you fast, dependable service on the items you'll need for Delco Radio—and other radio—service work. Delco Radio also provides:

- Wide selection of special application parts
- Complete technical training program
- Effective warranty program
- Dealer identification signs

Get the facts today on this truly profitable dealer setup, and grow with General Motors!

Available everywhere through Electronic Distributors associated with . . .



DELCO RADIO

DIVISION OF GENERAL MOTORS, KOKOMO, INDIANA

servicing NEW DESIGNS

by Thomas A. Lesh

The "Gruen Circuit" Goes Modern

In addition to the well-known multivibrator and *Synchroguide* circuits, a third type of horizontal oscillator-AFC system is still in current use. This is the so-called "Gruen" circuit which includes a sine-wave oscillator controlled by a reactance tube. Zenith is the only manufacturer now producing sets with this feature; but, since that company builds more than a half-million receivers per year, the serviceman has plenty of chances to apply whatever knowledge of the Gruen circuit he may possess.

The same basic design was employed for a number of years with very few major changes until the 1959 models came along. You could count on finding the following sequence of stages in a Gruen system; a dual-diode phase detector, a reactance tube, a modified Hartley oscillator, and a discharge tube. Recent models of sets have generally employed a 6CN7 dual diode/triode and a 6CG7 dual triode to perform all these functions.

This year, there's something new in the Gruen department. After trying out horizontal multivibrator circuits in a few of its portables, Zenith has switched back to a Gruen-type system—but in simplified form. A revised circuit, which first appeared in the 15B20 portable chassis, follows a modern trend by using a dual selenium diode as a phase detector. In addition, the oscillator and discharge-tube functions are both handled by one pentode section of a 6EA8. The other half of this tube (triode section) is used as a reactance tube.

In the new "C" series of Zenith chassis introduced this spring, use of the simplified circuit has been extended to many 21" and 24" receivers, as well as all portables. This one-tube Gruen setup is apparently here to stay, so let's analyze it and get ready to service it.

The new circuit is shown in Fig. 1 as it appears in early production runs of the 16C20 chassis. A very similar arrangement is found in Chassis 15B20 and 16C21.

Before getting into theory, we

should point out that all waveforms in this article were taken with the aid of a low-capacitance probe. An external sync signal was fed to the scope through a 47K-ohm isolating resistor from the grid of the horizontal output tube.

Phase Detector

The input stage of the simplified circuit is somewhat different from previously-used phase detectors. Sync pulses of negative polarity (W1) are coupled through C1A from the plate of the sync separator to the center or common-cathode terminal of phase-detector diode M1; therefore, both diodes are driven into conduction during sync-pulse time. Positive feedback pulses (W2) from an isolated winding on the horizontal output transformer are integrated into a sawtooth wave (W3), which is fed back to the phase detector.

At the instant a sync pulse arrives, the sawtooth is normally passing through some point in the positive-going or retrace portion of its cycle. The exact value of the sawtooth signal voltage at this instant depends on the relative phase of the signal, which in turn depends on whether the oscillator is operating above, on, or below the desired frequency.

Suppose the instantaneous value of W3 happens to be zero during sync-pulse time. (Theoretically, at least, this condition will occur at one certain oscillator frequency within the sync lock-in range.) In such an instance, the voltage contributed by the sawtooth signal won't

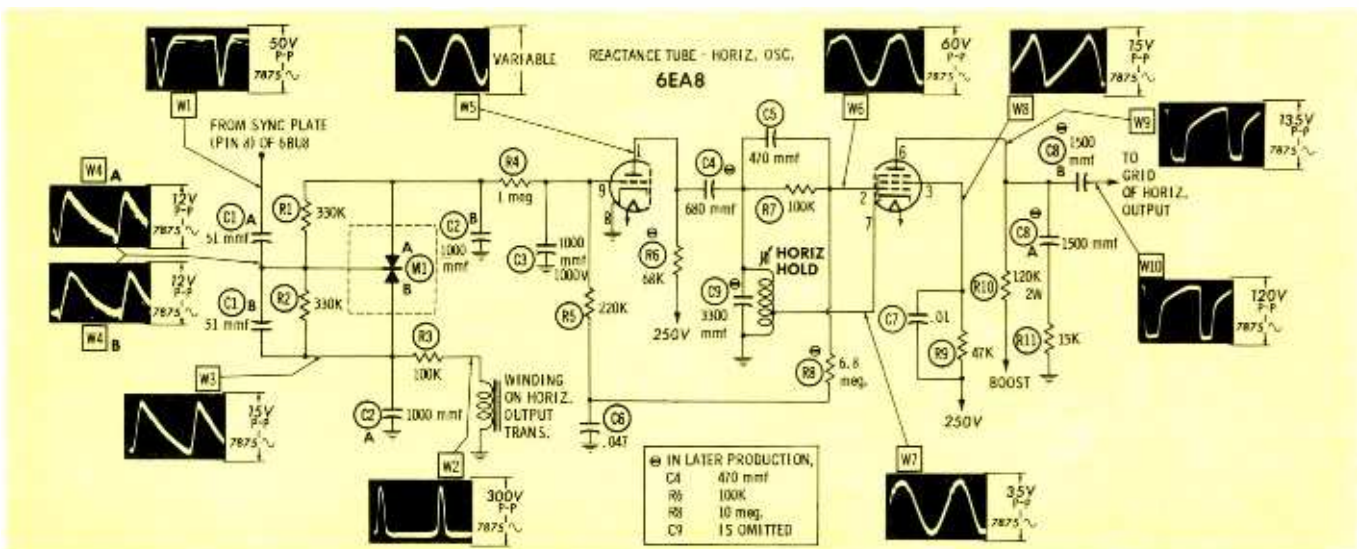

Fig. 1. Simplified version of the Gruen circuit used in Zenith Chassis 16C20.

effect diode conduction. Speaking in terms of theory again, the two diodes will conduct equally because they receive identical sync pulses at their common cathode. Thus, their outputs will cancel, and the phase detector will not develop any correction voltage for the oscillator. This is actually an oversimplification; in a practical circuit, the amount of conduction in M1A and M1B will be somewhat unbalanced due to various factors. This will cause some output voltage to be produced when the arrival of the sync pulses happens to coincide with zero sawtooth voltage. However, the voltage developed under these conditions will consistently have the same value because there will be a definite conduction ratio between the two diodes. This gives us a convenient starting point for our explanation of the phase detector.

Before proceeding with the discussion, we had better explain something about W3 which may appear puzzling. This sawtooth is not merely fed to the anode of M1B, but also appears at the other diode terminals. (Note the large sawtooth component in W4, the waveform at the common cathode.) This happens because a high-impedance "sneak circuit" is in parallel with C2A, the wave-shaping capacitor which plays a large part in developing W3.

Of course, the sawtooth wave appears across this parallel circuit as well as C2A. The sneak circuit is shown in Fig. 2, redrawn to show how it functions as an AC voltage divider. The reactances of C1B and C2B at the horizontal sweep frequency have been computed in order to indicate the part they play in the over-all circuit impedance. (Note: These capacitors will present a lower reactance to certain higher-frequency components which are present in the sawtooth signal, but the capacitance ratio of C1B and C2B will remain the same, regardless of signal frequency.)

A small portion of the signal is developed across the relatively low impedance of C2B; thus, a rather weak sawtooth will be found at the anode of M1A. As actually viewed with a scope, this waveform contains considerable hum and is difficult to see clearly.

Of the remaining two sections of the voltage divider, the one across M1B has less than half as much

THE GREATEST BREAK-THRU IN PICTURE RECEPTION SINCE THE INCEPTION OF THE FIRST YAGI ANTENNA!

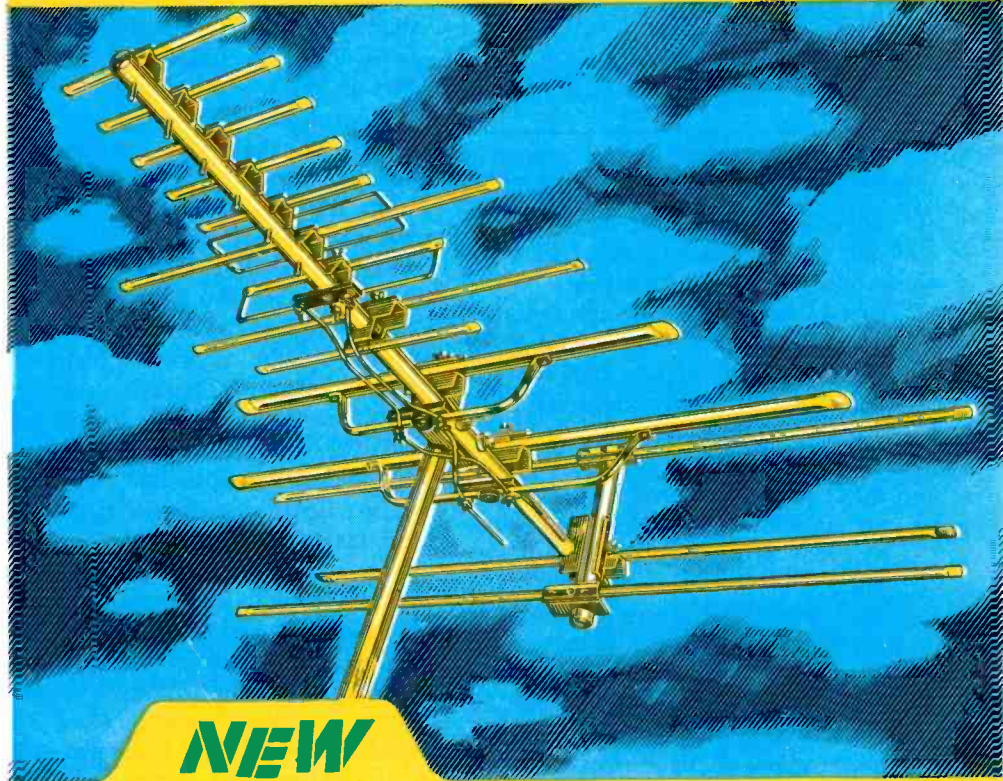

MIRACLE TV ANTENNAS by TENNA Give you the exclusive and Vastly Superior **MIRACLE REFLECTOR SYSTEM**

It's new, it's different and decidedly better! In the Miracle System the reflectors are "tuned" to produce highest directive results, providing the finest possible front to back ratio across the maximum number of channels.

**HERE ARE
ACTUAL FACTS...
ACTUAL PROOF
OF MIRACLE
SUPERIORITY!**

As an example, the front to back ratio on channel 3 of the Miracle TM-78 is 40 to 1. No other antenna of any manufacturer has ever achieved such a high ratio.

The Miracle Reflector when installed on competitive antennas invariably increased the gain by at least 25% and more than doubled the front to back ratio on the channel being tested.

GET ON THE MIRACLE BANDWAGON!

All America has long awaited the Miracle with its miraculous record of performance. Write, wire or phone collect today... the day of the Miracle is here!

THE TENNA MANUFACTURING CO. • CLEVELAND 25, OHIO

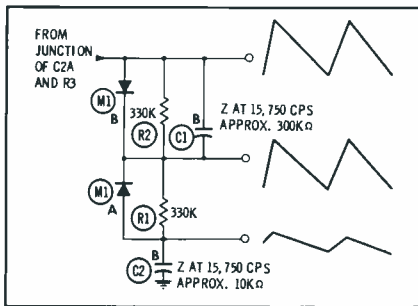

Fig. 2. This circuit acts as capacitive voltage divider for the sawtooth wave.

impedance as the one across M1A, due to the shunting effect of C1B. A comparatively small part of the signal should be developed across M1B, then, and we may expect a large signal to appear between the common-cathode terminal and ground. When we use a scope to examine the signal (W4) between these points, we find it does have an amplitude more than two-thirds as great as the input sawtooth signal.

Now that we know how W3 is applied to the phase detector, we should be better able to understand how the bias on the diodes can be affected by a change in the sawtooth signal. Let's suppose the oscillator frequency drifts down to a slightly lower value. Then W3 will be slightly "behind schedule", or lagging; it will have barely begun its rapid traverse from negative to positive by the time the sync pulse arrives at the phase detector. This means that the voltage contributed by W3 at pulse time will be more negative than it was before. The amplitude of this voltage will be greatest at the anode of M1B, less at the

common cathode, and very little at the anode of M1A. In other words, W3 at this time tends to make the anode of M1B more negative than the cathode; but it tends to make the cathode of M1A more negative than its anode. This amounts to reverse bias on M1B and forward bias on M1A.

The diode load circuit is connected so that M1A produces a negative output voltage (measured from the top of C2B to ground) when it conducts, and M1B's output voltage is positive. Under the conditions we have been discussing, M1A passes more diode current than M1B—so the resultant phase-detector output is negative. As we shall see later, this is the proper polarity of control voltage to speed up the horizontal oscillator.

In case the oscillator tries to go too fast, W3 "gets ahead" of the sync pulses; i.e., the sawtooth is farther along in its retrace period by the time the sync pulse arrives. This means that the instantaneous value of W3 will be more positive (or less negative) than normal when the diodes conduct. In a theoretical circuit (and in some circuits in actual use), the value of the feedback voltage becomes more positive than zero. M1B then receives forward bias, M1A has reverse bias, and the phase detector produces a positive output voltage which serves to reduce the oscillator frequency.

Operation of the circuit in Fig. 1, however, is not simply a matter of "oscillator faster than normal—control voltage positive." The reactance tube, which receives the phase-detector output, does not operate on a zero-center basis; thus, the phase detector is purposely unbalanced in order *not* to produce zero output when the oscillator is on the right frequency. The DC voltage at the top of C2B is actually about -2 volts at that time. When the horizontal hold control of a typical set is slowly varied over the entire lock-in range, the phase-detector output fluctuates from approximately -6 to +4 volts. An output within the range from -3 to +2 volts is required to pull the oscillator back into sync, once it drops out.

W4A and W4B give a visible clue to the slightly unbalanced nature of the phase-detector circuit. These waveforms represent the com-

bination of sawtooth and sync-pulse signals at the extreme limits of the sync lock-in range—W4A at the "slow" end and W4B at the "fast" end. Note that the sync pulse always appears to arrive during the early part of the retrace interval, rather than varying around the midpoint of retrace (as it should do, according to theory). Several factors are involved in this situation—not only the unbalance present in the circuit, but also the fact that the average DC voltage level of W4 is slightly positive and varies whenever the operating point of the circuit shifts. In any case, it can be seen that the sync pulse occurs at a more negative point on the sawtooth in W4A than in W4B. This change in the combined sync-and-saw waveform is fundamental to phase-detector operation.

Oscillator and Reactance Tube

The tuned tank of the sine-wave oscillator is connected from the grid of the 6EA8 pentode section to ground. Positive feedback to sustain oscillation is provided by returning the cathode of this section to ground through a portion of the oscillator coil.

The reactance tube (triode section of the 6EA8) and C4 are connected in series across the tank circuit to furnish a means of regulating oscillator frequency. Increasing or decreasing the plate current of the triode causes C4 to introduce more or less shunt capacitance across the tank, thereby either lowering or raising the frequency of oscillation. (If you're interested in studying reactance-tube operation in greater detail, refer to *Shop Talk* in this issue.)

Awhile back, we said that a negative-going change in phase-detector output would speed up the oscillator. The reason for this should now be clear. If the phase detector causes the grid voltage of the reactance tube to change in the negative direction, less plate current will flow in the tube. This has the same effect as placing more resistance in series with C4—the effective capacitance across the tank is reduced, and the frequency of oscillation goes up accordingly.

The phase-detector output voltage in itself is not sufficiently negative to maintain the desired level of bias on the reactance tube. Accord-

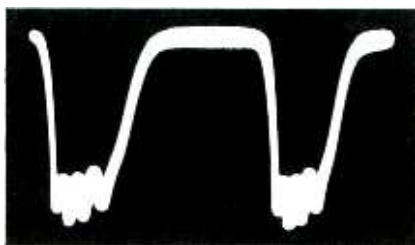

(A) Oscillator screen: 140V P-P.

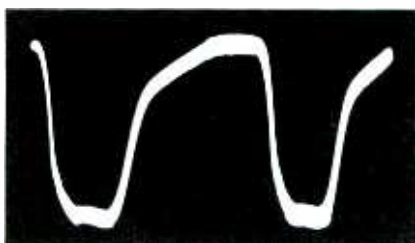

(B) Output-tube grid: 80V P-P.

Fig. 3. Abnormal waveforms—C7 open.



BUSS FUSES *can help you maintain customer good-will!*

Your customers stay satisfied with BUSS fuses because . . . BUSS fuses provide, dependable, 'trouble-free' electrical protection under all service conditions.

Every BUSS fuse you sell or install is tested in a sensitive electronic device. Any fuse not correctly calibrated, properly constructed and right in all physical dimensions is automatically rejected.

BUSS fuse dependability helps you gain satisfied customers — and BUSS fuses help you avoid adjustments or call-backs that cut into your profits.

BUSS fuses can further help you maintain your reputation for quality and service because BUSS is the KNOWN brand of fuses. The universal acceptance of BUSS fuses as the finest available is built on the millions upon millions of BUSS

fuses used in home, on farm and in industry over the past 43 years.

For more information on the complete line of BUSS and FUSETRON Small Dimension Fuses and Fuse-holders, write for bulletin SFB.

Bussmann Mfg. Division McGraw-Edison Co. University at Jefferson, St. Louis 7, Mo.

BUSS fuses are made to protect — not to blow, needlessly



A COMPLETE LINE OF FUSES FOR HOME, FARM, COMMERCIAL, ELECTRONIC, AUTOMOTIVE AND INDUSTRIAL USE.

759

PROFESSIONAL
technicians
use
Dave Rice's
OFFICIAL
ORDER BOOKS
for every
TV-RADIO
service
call



This is the businesslike approach to service record keeping. TriPLICATE forms serve as order form, invoice and office record, with spaces for complete information on every job. Separate listings for receiving tubes, pix tube, parts, serial numbers, labor and tax charges, signatures, etc. 75c a book, \$6.50 for dust-proof box of 10. In stock at your distributor. Write for your free folder describing Dave Rice's OFFICIAL ORDER BOOKS, including an actual size sample copy of the handy order form.

For customer's prices on every replacement part, plus flat rate and hourly service charge data, regional and national, Dave Rice's OFFICIAL PRICING DIGEST, listing over 63,000 items. \$2.50.

ELECTRONIC PUBLISHING CO., INC.
180 N. WACKER DRIVE
CHICAGO 6, ILLINOIS

VIS-U-ALL
BUSINESS BUILDING TEST EQUIPMENT FOR SERVICE DEALERS

NOW,
THE DYNAMIC
PORTABLE TUBE
TESTER THAT DOES
EVERYTHING



New V1003 tests 99% of all radio and TV tubes plus transistors and portable radio batteries!

No other tester like it at any price. Not only helps you do better, faster TV-radio servicing, but sells more tubes. Also checks all transistors and portable batteries under load (a Vis-U-All exclusive). Does all this with just 6 sockets, 3 knobs... simplicity unequalled! New and practical features galore!

ONLY \$129.00

Write
for
Details

VIS-U-ALL
PRODUCTS CO.
640 EASTERN, S. E.
GRAND RAPIDS 6,
MICHIGAN

ingly, a negative potential is fed from the oscillator to the reactance-tube grid through a filter and isolation network consisting of R8, C6, and R5. When the phase-detector output voltage is blended with this fixed bias, the resulting "hold-in" range (reactance-tube grid voltages at which the oscillator will stay in sync) is from -1 to -9 volts. The "pull-in" range (grid voltages required to bring the oscillator into sync) is from approximately -2 to -5.5 volts. Note that the reactance tube is not allowed to reach saturation. Incidentally, the method used in this circuit to prevent a zero-bias condition is different from the cathode-biasing arrangement employed in earlier Zenith designs.

The sine-wave nature of the oscillator circuit is clearly demonstrated by the shapes of W5, W6 and W7. Being a class-C circuit, the oscillator draws plate (and grid) current only during the positive peaks of the grid signal. The slight pip near the top of W6 and W7 represents the time at which the tube goes into conduction.

Discharge Circuit

In a conventional Gruen circuit, the horizontal output tube is not directly driven by the oscillator; instead, the drive signal is developed by an intermediate "discharge tube" stage. When a sample of the oscillator's grid signal is fed to the grid of this extra stage, the positive peaks drive the tube into conduction. The resulting plate current discharges the sawtooth-forming capacitor (corresponding to C8A in Fig. 1), thus producing the retrace portion of the horizontal drive signal. In between positive peaks of the oscillator signal, the discharge tube remains cut off while C8A charges gradually from the boost B+ source. One of the greatest advantages of the separate discharge tube is the isolation it provides between the oscillator and output tubes.

Since the conduction pattern of the oscillator is actually very similar to that of the discharge tube, the former can take over the function of the latter — provided that the sawtooth-forming circuit can be prevented from loading down the oscillator. In the new circuit, Zenith has taken care of this isolation problem by using a pentode for the oscillator tube. The plate

current of a pentode is practically independent of the plate voltage; therefore, the voltage in the plate circuit can be allowed to vary as shown by W9 without unduly interfering with oscillation. In a sense, the oscillator is actually a triode consisting of the cathode, control grid and screen grid—and the discharge circuit is rather loosely coupled to the oscillator through the tube's electron stream.

The voltage across the sawtooth-forming network (C8A and R11) appears as shown in W9. The drive signal applied to the output tube (W10) is practically identical in shape to W9 but somewhat lower in amplitude. Notice that these waveforms have much wider negative retrace pulses than the drive waveforms you ordinarily see in multivibrator and *Synchroguide* circuits. As long as these pulses have sharp leading edges and start at the correct time, their unusually great width will not adversely affect circuit operation. You can make the drive voltage as negative as you please during the beginning portion of trace time, since the horizontal output tube is not conducting at this time anyway.

Hold Control

The earliest version of the simplified circuit (Chassis 15B20) includes a resistive hold control in addition to a frequency-adjustment slug. This 100K-ohm potentiometer and a 47K-ohm fixed resistor are wired in series and used in place of R6.

In the latest circuit, where the frequency slug itself serves as a hold control, the rear-panel control knob is equipped with stops to prevent the customer from rotating the slug more than 270° (see *Previews of New Sets* for May). However, the serviceman can remove this knob and use the shaft to rotate the slug as many turns as necessary.

Troubleshooting

The Gruen circuit is not immune from the trouble-isolation problem which often bothers servicemen while working on horizontal circuits: "Is the defect in the AFC or in the oscillator itself?" But you can apply to Gruen circuits the same isolating technique which works so well with multivibrators; i.e., you can disable the phase-detector stage. It's possi-

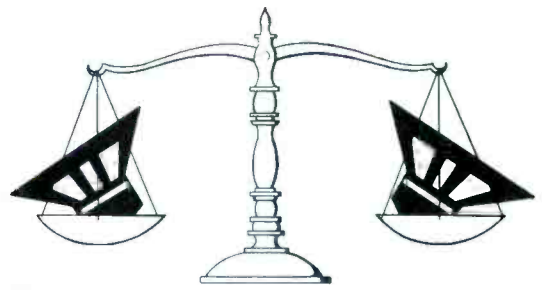

Stereo balance

made easy with

Clarostat dual channel

controls

Series AD47

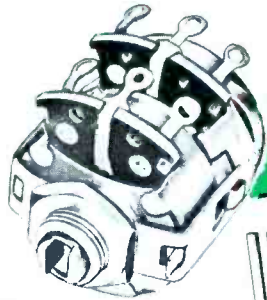

In stock, high-quality balance for stereo sound—Clarostat dual-channel 1/2-watt carbon controls. Two completely isolated pots on a common shaft that permit a variety of balancing operations on the input side of dual channel amplifiers. A wide range of values meets every usual requirement.

- FOR VOLUME CONTROL
- FOR TONE CONTROL
- FOR BALANCE CONTROL
- FOR BIAS CONTROL

Write for complete catalog.

with your choice of shaft ...

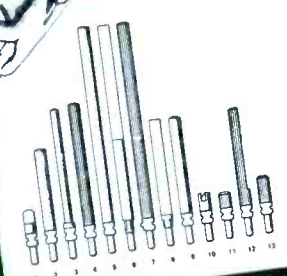

Takes any one of 13 standard shafts. Offering choice of length and configuration.

with or without switch ...



Series SWE "AD-A-SWITCH" permits easy, fast attachment in the field. Various pole arrangements and current ratings.

in appropriate tapers ...

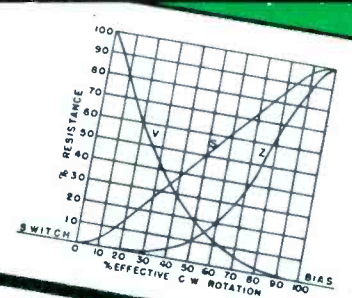

S, V, and Z tapers available. Permits best control for specific amplifier characteristics.



Controls and Resistors

CLAROSTAT MFG. CO., INC., DOVER, NEW HAMPSHIRE
In Canada: CANADIAN MARCONI CO., LTD., TORONTO 17, ONT.



**QUICK-SILVER FOR YOU...
MERCURY FOR US**

Merit shipments to all parts of the United States are jet-fast, and sure as sunrise. Mercury, the mythical god, would be pleased.

MERIT CONSISTENT QUALITY PLUS FAST DELIVERY MEANS QUICK-SILVER FOR YOU... EXTRA-DOLLARS AND BIGGER PROFITS.



COMPARE IT WITH

MERIT
MERIT COIL AND TRANSFORMER CORP
MERIT PLAZA . HOLLYWOOD, FLORIDA

ask the
"Man-on-the-Roof"
why he prefers
South River

TWO TO A SET

RATCHET TYPE CHIMNEY MOUNT
Model RT (Galv. Banding)
Model RT-ST (Stainless Banding)

FASTEST, SIMPLEST, MOST CONVENIENT EVER MANUFACTURED — Mounts in 2 simple steps. Completely factory assembled with no eye-bolts, banding clips, nuts, etc., to handle. Furnished with flat-lay, non-coiling banding, heavy gauge embossed, welded steel construction. Forged heat treated Alum. ratchets.

SOUTH RIVER pioneer & outstanding producer of finest line of antenna mounts
METAL PRODUCTS CO., INC.
South River, New Jersey
Canada: Len Finkler & Co., Toronto

ble to test the condition of the oscillator by simply grounding the junction of C2B and R4. If all is well in the reactance-tube and oscillator stages, you will almost—but not quite—be able to lock in the picture by manipulating the hold control. The picture will tend to roll side-wise in either direction, like a scope waveform which isn't solidly synchronized. The Gruen circuit seems to have very little tendency to "Christmas-tree", or tear horizontally.

The oscillator circuit is relatively simple and should be fairly trouble-free, but an occasional component defect could conceivably develop. If screen-bypass capacitor C7 opened, waveform W8 would change from a weak sawtooth to the fierce-looking pulse shown in Fig. 3A. Then W10 would degenerate into something similar to Fig. 3B, resulting in insufficient drive to the output stage.

Component defects in the reactance-tube grid circuit can produce various odd sync troubles. If R8 opens, the customer may call you with a complaint of lost horizontal sync. You'll probably be able to lock in the picture by pulling off the hold-control knob and readjusting the slug, but sync will still be somewhat critical. Checking tube-pin voltages, you'll find insufficient negative voltage at pin 9 of the 6EA8. The control voltage from the phase detector will still be present, but you've lost the fixed-bias component of the reactance-tube grid voltage.

If C6 opens, the fixed bias will no longer be filtered, so you'll find extremely critical sync and severe "pie-crust" or ripples in the raster.

A shorted C6 will cause you to lose most of the phase-detector out-

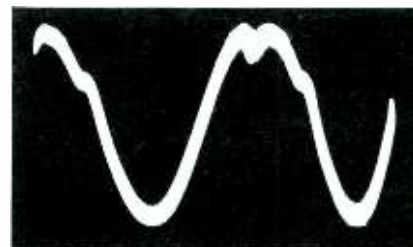

(A) At plate of reactance tube.

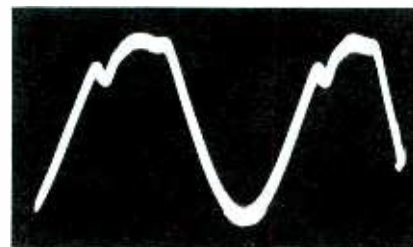

(B) At grid of oscillator.

Fig. 4. Distortion of normal signals due to use of internal sync on scope.

put voltage, so sync will be extremely critical. The picture will move from side to side at a speed somewhere between a rapid floating motion and a slow jitter.

Watch out for those selenium diodes! Although many defects in M1 will produce touchy sync, a whole catalog of other symptoms can be caused by various types of failure in this component. If you suspect phase-detector trouble, try replacing M1 as your first move. You'll find it attached to a terminal strip underneath the chassis.

One last hint: Don't be unduly alarmed by any mysterious pips you may see in the waveforms associated with the oscillator tank. Certain conditions of measurement may exaggerate normal irregularities in the positive peak of the waveform. For example, Figs 4A and 4B show W5 and W6 as they appeared when we used internal instead of external sync for the scope. See what we mean? ▲

SAVE TIME with SENCORE

Transi-Pak
A "Twin" to the SENCORE TRC4 Transistor Checker

See other SENCORE ads in this issue.

A Low Cost TRANSISTOR RADIO BATTERY ELIMINATOR

Here is a complete isolated power supply especially designed to replace batteries during repair time of all transistor radios.

- ★ Supplies up to 24V D.C
- ★ Provides 100ma constant and 200ma on peaks
- ★ Meter indicates either voltage or current
- ★ 1.5 volt biasing tap for Philco and Sylvania Transistor Radios

MODEL PS-103 \$17.95 DEALER NET

SERVICE Instruments Corp.
121 Official Road, Addison, Ill.
AT LEADING PARTS DISTRIBUTORS

For ultimate quality in audio amplification

Tung-Sol audio tubes dynamically balanced and twin-packed in matched pairs by the manufacturer

Now you can come as close to faultless sound reproduction as the design and circuitry of your hi-fi equipment will permit. Tung-Sol 5881 and 6550 beam-power amplifier tubes are dynamically balanced and factory-matched to very tight performance limits to help you achieve lowest distortion at all volume levels.

Use of Tung-Sol 5881 and 6550 tubes has long been associated with

amplifiers of the very finest design. These tubes have always been produced to closest possible tolerances with cathode current ranges held to an absolute minimum.

Now, in twin-packed pairs, they assure the hi-fi enthusiast and the commercial sound engineer of replacement tubes that will provide new standards of performance—a feature of special importance with

the newest amplifiers and loudspeakers, particularly binaural sound equipment.

Service dealers will find the use of these tubes for replacement a source of profitable customer appreciation. Tung-Sol Electric Inc., Newark 4, New Jersey.

 **TUNG-SOL®**



5881

For service in amplifiers of up to 50 watts.

6550

For service in amplifiers and commercial audio equipment of up to 100 watts.



DON'T SAY "BRIGHTENER"
SAY



UNIVERSAL
TV TUBE BRITENER
Engineered for quality . . .
and fully guaranteed!

Model C-301 For use in Series
or Parallel Wired Sets
List Price \$4.45



Unique design allows operation as constant voltage or constant current transformer. Gives 6.3 or 7.8 volts output with Isolation on Series or Parallel sets. Works on electrostatic or electro-magnetic focus picture tubes. Relieves Cathode - Filament shorts, without Boost output.

DON'T SAY "BRIGHTENER"
SAY



VU-BRITE
Engineered for quality . . .
and fully guaranteed!

Model C-401 For use in Series Sets
Model C-402 For use in Parallel Sets
List Price \$1.49

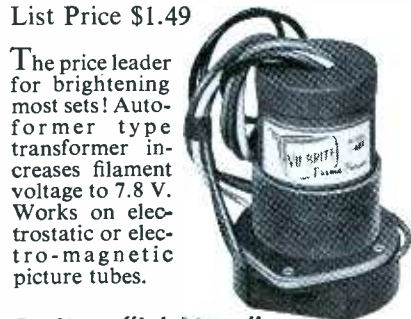

The price leader for brightening most sets! Auto-former type transformer increases filament voltage to 7.8 V. Works on electrostatic or electro-magnetic picture tubes.

Don't say "brightener"
Say **PERMA-POWER**
The Standard of All Comparison
Available from your parts distributor
PERMA-POWER COMPANY
3106 N. ELSTON AVE., CHICAGO 18, ILL.



Tubes Tested by Experts. We keep hearing crazy stories about people's misadventures with self-service tube testers. Just recently, a friend from across town told us he had serviced a set in which *all* the tuner and IF tubes were burned out! A few discreet questions unearthed the fact that the owner had tested these tubes himself. The way we figure it, somebody must have tested a 25- or 50-volt tube in the machine just before this particular customer came along — and the poor guy didn't reset the filament-voltage control according to instructions.

A certain percentage of the public will always insist on taking the tubes out of their own sets for testing! To prevent non-technical "tube merchants" from running away with all this do-it-yourself business, many TV shops have tried window posters and advertisements bearing the invitation, "Tubes Tested Free." Somehow, this message doesn't seem to register with many people. Maybe they suspect a "come-on" because of experience with previous free offers in which the only thing they got "free" was a high-pressure sales talk.

Free professional testing *can* remedy the do-it-yourself problem to some extent—but only if it is promoted aggressively. Advertisements need to carry a fairly strong message such as the following: "A trained TV man can *save you money* by testing your tubes for you. Robot testers can't always tell you what you really want to know — whether or not a tube is able to perform normally *in your set*. When you come to our shop to test your tubes, you get the benefit of our technical advice — with no obligation."

As we've implied, it takes concentrated effort to bring tube testing back to service establishments. A large number of shops in the same general area might find it helpful to band together for this purpose. It's been done! Successfully, too—Burs-

ma Radio Supply Co., Grand Rapids, Mich., has been cooperating with numerous local shops in a unified campaign featuring large newspaper ads and bright, easily-recognized display banners. Advertising copy stresses the theme that participating shops have high-quality tube testers backed up with sound advice from qualified servicemen.

There's one drawback to this tube-testing activity. When all the work is done by the serviceman himself, it can't help but take a great deal of time out of his busy schedule. If this dilemma is bothering you, here's a suggestion to cut down on the effort required: Have a simple - to - operate, self-service tester available in the shop (with clear instructions) so that the customer himself can weed out the tubes which give positive "good" and "bad" indications. Then invite him to confer with you about borderline cases, so you can help him determine whether the tube's condition is bad enough to affect set operation.

\$ & C

**Once you have found him,
Never let him go . . .**

Rogers and Hammerstein certainly didn't have the TV serviceman in mind when they penned these famous lyrics; all the same, they very nicely summarize people's feelings toward a serviceman who has proved himself to be thoroughly reliable. All the irresponsible talk about "service gyms" and incompetent repairmen has had its bright side—it has made the public more inclined to remain loyal to a TV man who succeeds in giving satisfaction.

To be that man, concentrate on putting your best foot forward as a capable technician and a good friend. Then let the lowliest of the herd cut their service charges if they wish. People will recognize the difference between your work and theirs—and stick with you.

A new kind of TV

RCA VICTOR SPORTABLE TV!



the easiest-to-service portable in TV history...



1. 98% OF ALL SERVICE can be done from rear of set with back cover removed! All fuses, tubes and most other parts are easy to reach. No need to remove the chassis.



2. WIRING PATTERN is traced in white on the exposed side of the Security Sealed Circuits. New "road-map" technique and clearly marked component numbers provide easy location, easy repair.



3. KINE CAN EASILY BE MOVED forward in operating condition! No "patch" cables needed. Just plug in a cheater cord.

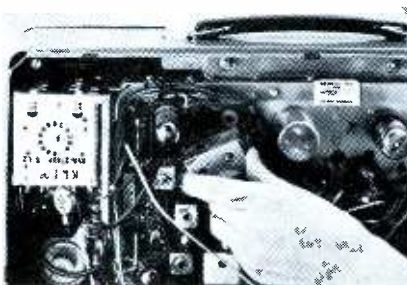

4. DIODE DETECTOR SHIELD removes without cutting or unsoldering. Just slip the shield off and go to work!

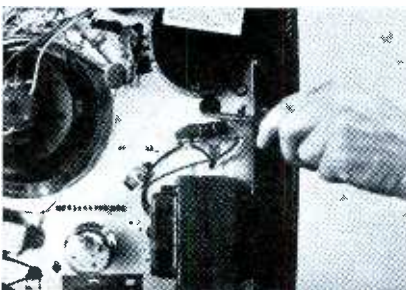

5. SPECIAL APERTURE enables technician to discharge kine before service.

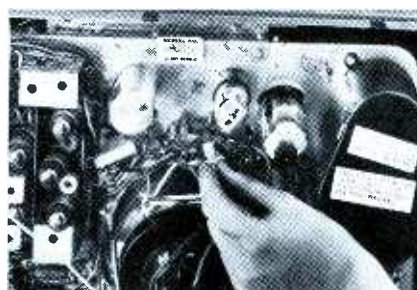

6. FOCUS-VOLTAGE selector strip offers a range of voltages for fine focusing.

OTHER IMPROVED FEATURES:

- Reach the most-used technician controls—AGC, vertical height and linearity *without removing back cover!* You can adjust horizontal drive and width easily with back cover off.
- Socket connections handy for quick, easy probe-testing.
- Power-transformer chassis for greater safety and speedy location for tube replacements.
- Epoxy-coated capacitors are four times more moisture-resistant than old-style capacitors. Reduce service problems and give longer operating life to the set.
- RCA chemical fuse gives complete protection—doesn't "blow" from nondangerous momentary power overloads that open ordinary fuses.

RECOMMEND THE PORTABLE THAT MAKES YOUR SERVICING JOB EASIER—
NEW SPORTABLE TV!



RCA VICTOR
TRADE MARK
RADIO CORPORATION OF AMERICA



NOTES on test equipment

informative reports from the lab

by Les Deane

Tester with Plug-in Panels

The Model 6000 Tube Tester, manufactured by Hickok Electrical Instrument Co. of Cleveland, is pictured in Fig. 1. This dynamic mutual conductance tester not only checks all tube types, but also features tests for transistors, rectifiers, and semiconductor diodes. With its attractive portable case and easy-to-read meter, the instrument is ideal for home service calls.

Specifications are:

1. Power requirements—105/125 volts AC, 60 cps; power consumption 40 watts; No. 81 auto-type lamp for panel line fuse; line voltage adjustment provided on panel.
2. Tube Test—5 panel lamps indicate shorts or leakage and identify faulty elements; continuity check and filament voltage of .6 to 117 volts in 18 steps provided; mutual conductance and special life reserve test for all amplifier tubes; grid current or gas test indicated in microamps.
3. Transistor Test—PNP and NPN junction or point-contact transistors checked for gain and leakage current; special sockets provided on panel.
4. Rectifiers and Diodes—copper oxide, selenium, silicon, or germanium units tested for forward-to-reverse conduction ratio; special jacks provided on front panel.
5. Other Features—plug-in socket panels, popular tube types grouped on roll chart; No. 49 pilot lamp serves as bias fuse; 5" meter with tube-test scales of REPLACE-?-GOOD and 3 ranges of from 0 to 3,000, 6,000, and 15,000 micromhos; transistor scale of

GOOD-?-POOR plus a 0-to-100% linear scale.

6. Carrying Case—approx. size 7½" x 16¾" x 11", weight 16½ lbs. with removable lid.

Putting one of the Model 6000's through its paces in the lab recently, I found that the above specifications speak for themselves. All tubes delivering not more than 25 watts of power can be tested for shorts, leakage, mutual conductance, and gas by a simple lever-and-switch setup.

Shorts are automatically indicated by five neon lamps located under a small light shield in the center of the panel. The circuit is designed so that these lamps glow when the tester is turned on; if the tube under test is not shorted, they will remain lit. If a short is indicated, by one or more of the lamps going out, the tube should be discarded without further testing. A special chart showing exactly what tube elements are shorted is provided in the instrument's instruction manual.

A new design feature of particular interest is the separate plug-in panel housing the necessary test sockets. The panel, shown removed in Fig. 2, is a standard six-socket unit supplied with the Model 6000. According to the manufacturer, field surveys indicate that 95% of all tubes in active use can be tested in the six different sockets on this one panel. For the tester to accommodate older types, or foreign and special-purpose tubes, however, other



Fig. 2. Socket panels plug into an 11-pin adapter held in place by two screws.

adapter panels are available at relatively low cost.

Another feature I noticed about the test panels is that each socket is held in place by a spring-clip arrangement. This method of mounting, pointed out in Fig. 3, makes it easy to replace the individual sockets should it ever become necessary.

After reading over the instructions completely, I became aware of the fact that this tester not only checks mutual conductance of tubes under dynamic conditions, but that it also provides a special life test. This reserve capacity test is actually a comparison of the tube's normal mutual conductance with that obtained under slightly adverse conditions. Since power-line voltages vary with different localities, and even with different hours of the day, tubes out in the field may often be called upon to operate with lower than their specified filament voltages. In this instance, if the tube does not have a sufficient reserve power, it may not be functioning properly in the set and yet pass the normal tests of a tube checker. This situation is frequently encountered in TV receivers with series filaments and in auto radios where battery voltage may tend to drop when lights, fans, etc., are operated at the same time.

To perform this special test using the Hickok 6000, I first measured mutual conductance of a tube under suspicion in the ordinary manner. As outlined in the manual, I adjusted the panel SHUNT dial until the meter needle indicated in the good region at 2000 on the 0- to-3,000 micromhos scale. Without disturbing any other panel setting, I then reduced the filament voltage applied to the tube as recommended in the manual, and again noted the mutual conductance reading. The needle remained in the green or good sector, indicating that the tube should have enough reserve capacity to perform under the adverse conditions previously mentioned.



Fig. 1. Hickok's 6000 offers an automatic shorts test and quick heater check.



Fig. 3. Each large socket is held by a spring clip for easy replacement.

New "Tele-Volter"

The Model 590 *Tele-Volter*, pictured in operation in Fig. 4, is a vacuum-tube voltmeter recently produced by Jackson Electrical Instrument Co., Dayton, Ohio. This combination portable and bench instrument is designed to measure a wide range of voltages and resistances normally encountered by radio and TV servicemen. It comes complete with test leads, isolation probe, line cord, and instruction manual.

Specifications are:

1. Power Requirements—115 volts AC, 50/60 cps; power consumption 6 watts; one self-contained 1.5-volt battery; on indicator provided on panel.
2. DC Voltmeter—ranges 0 to 1, 5, 10, 50, 100, 500, and 1,000 volts; input resistance 11 megohms; polarity selector provided; zero-center scale for ranges of from 0 to .5, 2.5, 5, 25, 50, 250, and 500 volts; accuracy $\pm 3\%$ of full-scale deflection.
3. AC voltmeter—rms ranges of 0 to 1, 5, 10, 50, 100, 500, and 1,000 volts; peak-to-peak ranges of 0 to 2.8, 14, 28, 140, 280, 1400, and 2800 volts; input impedance .2 megohms shunted by 100 uuf; accuracy 5% of full-scale deflection from 20 cps to 2 mc.
4. Ohmmeter—ranges Rx1, 10, 100, 1K, 10K, 100K, and 1 meg; center scale 10; accuracy 3% of total scale length; zero- and ohms-adjust provided on front panel.
5. Size and Weight— $10\frac{1}{4}'' \times 7\frac{1}{4}'' \times 5''$; 6 $\frac{3}{4}$ lbs. net.

When working with the Model 590, its outward design features first caught my attention. The all-metal

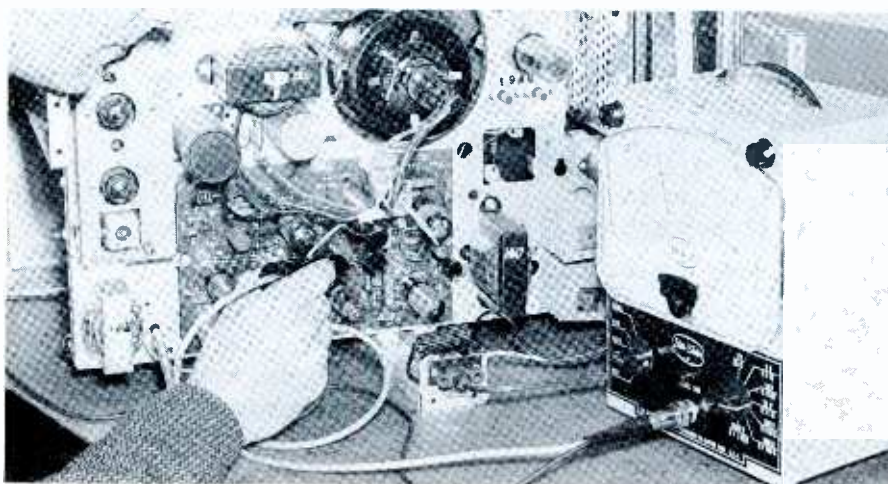

Fig. 4. Jackson's 590 features balanced bridge circuit using 12AU7 dual triode.



Fig. 5. The *Tele-Volter's* easy-to-read scales are green, red, blue, and black.

case has an attractive gray stippled finish with chrome carrying handle, and the front panel is trimmed in black with white lettering and red control knobs. The zero- and ohms-adjust controls are located in the top corners of the panel, while the range selector is positioned on the right side below the meter. The function switch, having five positions of OHMS, ACV, +DCV, -DCV, and OFF, is found on the lower left side of the panel opposite the range selector.

I also noticed that the test leads are attached at the bottom center of the panel by a single coaxial screw-type connector. Two 4' leads extend from this point—a black ground lead with alligator clip and a gray coax lead terminating in an isolation probe. The probe houses a

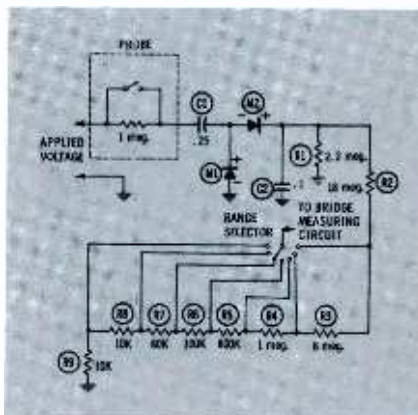

Fig. 6. Partial schematic of the Model 590 showing its AC/p-p input circuit.



you may now select
from two magnificent

SHURE

Stereo Dynamic

HI FI PHONO CARTRIDGES

Shure High Fidelity Stereo Dynamic phono cartridges are designed to satisfy the most critical requirements. Made under custom laboratory conditions, each unit is checked electrically, mechanically and acoustically to insure trouble-free performance.



PROFESSIONAL

MODEL M3D

AT \$45.00*

*audiophile net,
with 0.7 mil diamond

Incomparable quality—the overwhelming choice of independent critics and experts. Floats at only 3 grams in transcription tone arms. Distortion-free response from 20 to 15,000 cps. Superbly designed and built to perfectionist tolerances.

CUSTOM

MODEL M7D

AT \$24.00*

*audiophile net,
with 0.7 mil diamond



Outclasses every cartridge except the Shure M3D—by actual listening tests! Tracks perfectly at minimum pressure available in record changer arms. Smooth from 40 to 15,000 cps.

Use Only Shure Replacement Styli...
Inferior imitations can seriously degrade the performance of the cartridge.

Literature available: Department 15-G

SHURE BROTHERS, INC.

222 Hartrey Avenue, Evanston, Illinois

XCELITE PLIERS

have a . . .

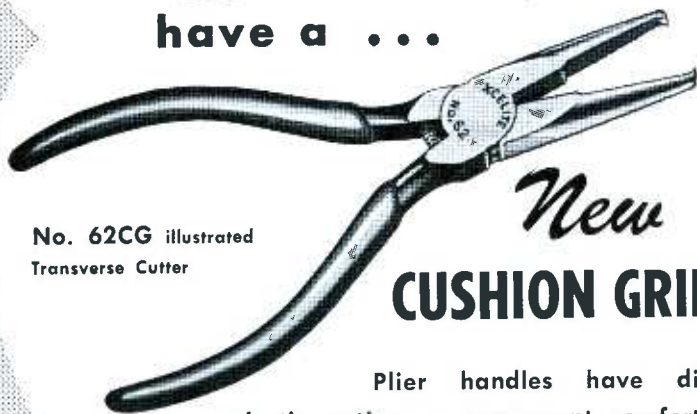

No. 62CG illustrated
Transverse Cutter

New
CUSHION GRIP!

Plier handles have dipped
plastic coating . . . permanent, comfortable.
Heads polished and buffed to a "mirror finish".
All pliers available . . . See Your Distributor!

Gives pliers a "Feel" that inspires Craftsmanship!

XCELITE, INCORPORATED
ORCHARD PARK, NEW YORK
Canada: Charles W. Pointon, Ltd., Toronto

XCELITE
Quality Hand Tools
PREFERRED BY THE EXPERTS

Make More Money in Servicing FIX RADIO SETS FAST!

You can cash in on the big radio revival—if you're prepared. What with transistors, printed circuits, portables, hybrid auto radios, FM sets—there's more to servicing radios than in the days of the ac-dc jobs. But the money's there if you know how to handle them. Here's a book that shows you how to spot and fix troubles in any set in minutes. Symptoms arranged alphabetically for quick reference. Four helpful sections—Receivers, Techniques, Servicing, Troubleshooting Charts. Get your copy and watch your income grow. It lists for \$4.60—but here's...

HOW TO GET THIS BOOK FOR ONLY \$3.35

Through the G/L Technicians' Book Club you can get this book and others equally valuable for only \$3.35—a 27% saving!

HOW TO JOIN

- Fill in this coupon.
- SEND NO MONEY—we send you the book on approval.
- If you like it, send your remittance; if not, return the book.
- You receive a new book every three months on the NO-RISK approval plan.
- You need take only four books during the entire membership period. No time limit.
- You may cancel any time after that.



RAPID RADIO REPAIR

By G. Warren Heath
(Author of "Rapid TV Repair")

224 pages. Deluxe gold-stamped hard cover.
List price \$4.60

NO-RISK COUPON

Gernsback Library Inc. PR-79
154 West 14th St., New York 11, N. Y.

- Enroll me in the G/L Technicians' Book Club. Send me my copy of RAPID RADIO REPAIR.
- Send me more information on the G/L Technicians' Book Club.

Name.....
please print

Street.....

City.....Zone..... State.....

1-megohm isolation resistor and a thumb switch for either Ohm/AC or DC functions. The series isolation resistor, of course, is only used when measuring DC voltages.

I have shown a close-up of the large meter face in Fig. 5. Coupled with a 200-microamp movement, it features six scale arcs representing all ranges listed in the above specifications. The two small lower arcs are special AC scales of 0 to 1 volt rms and 0 to 2.8 volts peak-to-peak. These scales must be used when the range selector is in its 1-volt position.

I also discovered that the instrument has a zero-center scale, which is very convenient for making bias measurements and performing TV sound alignments. Making use of this scale, I found that the range selector must be set to a value equal to or greater than the total positive and negative swing anticipated, and the function switch must be set to its +DC position.

When using the AC peak-to-peak measuring faculties of this instrument, I felt that some of you might not fully understand the operation and applications of such a peak-reading instrument. The input rectification circuit employed in the Model 590 is designed so that a true indication of peak-to-peak voltages can be read directly, regardless of the wave shape of the applied signal. You might remember, however, that this is not true of all VTVM's.

The basic AC-measuring circuit is shown in Fig. 6. Note that components C1, C2, M1, and M2 form a simple voltage doubler network which rectifies both positive- and negative-going portions of any signal applied. The DC output of this circuit, which is obtained across C2, is then applied to the range divider network R3 through R8. From the appropriate point on this divider, the representative voltage is then fed to the control grid of the VTVM bridge tube.

For all practical applications, therefore, the peak-to-peak indications of this particular meter can be used to troubleshoot just about any circuit of a television receiver. Although you may be able to determine the accurate peak-to-peak value of a signal, remember that in many cases its wave shape is just as important as its amplitude. ▲

ownership of a **PHOTOFACT** SERVICE DATA LIBRARY SPELLS SUCCESS FOR SERVICE TECHNICIANS

"PHOTOFACTS are a tremendous aid to a service technician in that they save hours of unnecessary work."

—E. C. Cenardo,
("Tune-In" TV-Radio
Sales & Service),
Hollywood, Calif.

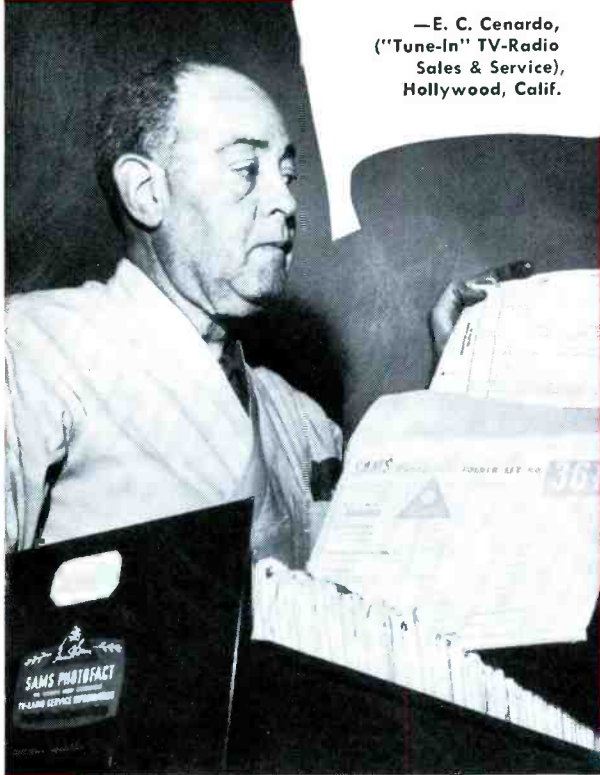

here's actual
proof from the
men who know

"It is impossible to do business without PHOTOFACT. It is a standing order* in our shop to pull PHOTOFACT from the file for every shop job, regardless of the technician's familiarity with the set. We have proved repeatedly that it cuts time on every job."

—W. R. Schoppe,
(Lakewood Television Service),
Jacksonville, Fla.

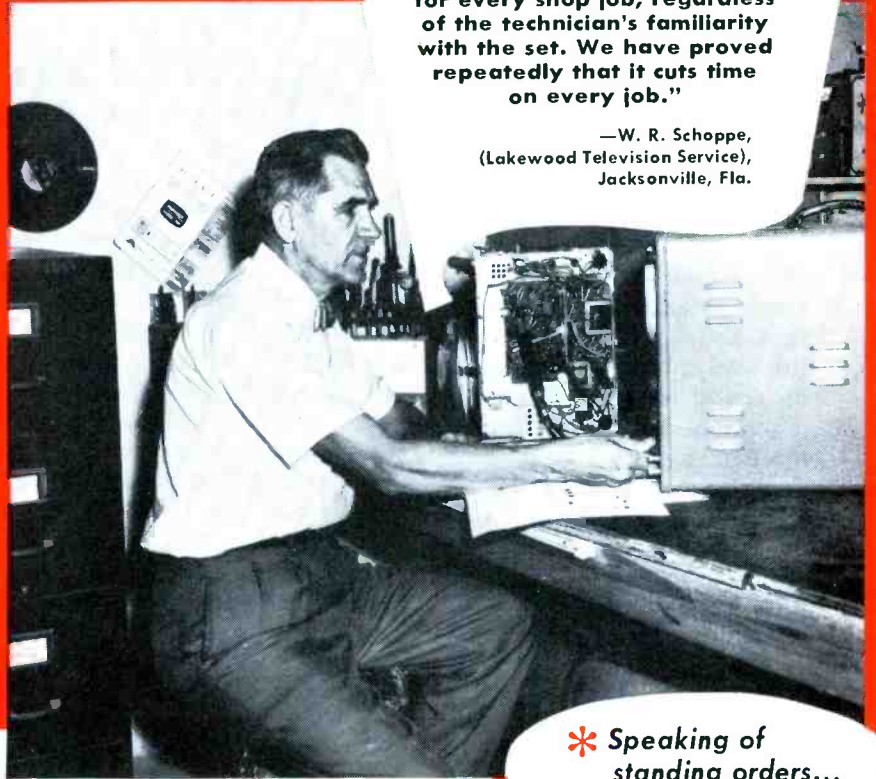

* Speaking of
standing orders...

you'll find the truly successful Service Technicians are those who stay ahead because they're on a Standing Order Subscription with their Distributors to receive all new PHOTOFACTS as released monthly...

For Standing Order Subscription and Easy-Buy Plan details, see your Sams Distributor today, or write to Howard W. Sams...

HERE'S MORE PROOF...FROM COAST-TO-COAST

"PHOTOFACTS mean so much to my business that I would not think of operating for any length of time without them."
—James G. Haynes
Leitchfield, Ky.

"The PHOTOFACTS that I have purchased on the Easy-Buy plan have been paying for themselves each month."
—Donald Johnson
Hector, Minn.

"PHOTOFACT means faster service to my customers, and more sets through my shop, which means more profit to me."
—Frank J. Schumacher
Hillsboro, Ore.

"I would be lost without SAMS PHOTOFACT. PHOTOFACT has become a part of servicing."
—Joseph S. Musil
Stamford, Texas

"PHOTOFACT means quicker and more efficient service to the customer."
—Wesley F. Scott
Logansport, Ind.

"Would not be without my PHOTOFACTS. Their return in time saved on servicing, pays for their cost many times over."
—E. R. Hayes
Clemson, S. Car.

(These are just a few of the hundreds of "Success with PHOTOFACT" letters in our files)

NEW EASY-BUY PLAN!

It's the money-saving way to build your complete profit-making PHOTOFACT Library!

NO INTEREST—NO CARRYING CHARGE—AS LITTLE AS \$10 DOWN

FREE! Valuable steel file cabinets given to PHOTOFACT monthly subscribers and Library purchasers.

Valuable booklet shows you how PHOTOFACT boosts your profit-capacity

Send for it!

FREE



HOWARD W. SAMS & CO., INC.
2201 E. 46th St., Indianapolis 6, Ind.



- Send me Free booklet "Your Guide To Maximum Profits"
 I'm a Service Technician: full-time; part-time

My Distributor is: _____

Shop Name _____

Attn. _____

Address _____

City _____ Zone _____ State _____





QUICKER SERVICING

By Calvin C. Young, Jr.

Unusual Tube Troubles

Tube substitution, as practiced by many servicemen, consists of replacing suspected tubes one at a time and noting the effect on the trouble symptom. If for any reason the defect isn't cured, the old tube is reinstalled before substituting for the next suspected tube. If only a single tube is causing the trouble, this procedure will prove effective; however, if two or more tubes are contributing to the trouble, this form of tube substitution is a waste of time.

Picture Bends

Consider, for example, the case of a Philco TV set that operated fine on weak signals but suffered from the bends on strong signals. The defect seemed to become worse as ambient temperature of the set increased. The serviceman had attempted to substitute all suspected tubes at one time, but since only two 6AU6's were available he wasn't able to replace all three 6AU6's used in the video IF strip (Fig. 1). Having failed to locate the source of the trouble via tube substitution,

the serviceman pulled the chassis and returned to the shop.

Voltage measurements with a VTVM revealed an abnormal drop across R39 and R40 in the AGC line, so the serviceman decided to check the AGC filters for leakage. Failing to find any defects, the next step was to disconnect the grid ends of C33, C41 and C45 and check them for DC leakage with a VTVM—again, no results. Faced with all the evidence (abnormal voltage drop, no leakage in the AGC filters, no leakage in the coupling capacitors), the serviceman came to the conclusion that the tubes must be drawing grid current. After replacement of all three 6AU6's cured the trouble, he knew this was the case. Subsequent tests of the tubes in a high-quality tester revealed that all three were gassy when heated.

During the troubleshooting procedure, it was noticed that advancing the contrast and brightness controls caused the picture to lose detail, and to white out in the center. When you encounter this symptom, it would be a good idea to substi-

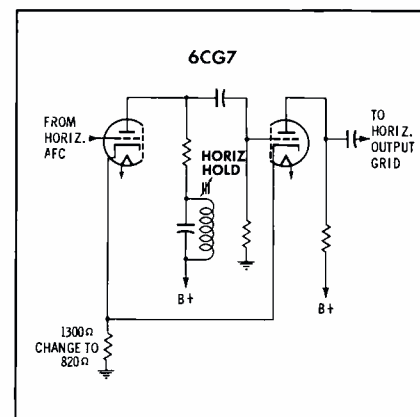

Fig. 2. Lowering cathode resistor value improves horizontal oscillator stability.

tute all AGC-controlled IF tubes right away and eliminate time-consuming jobs such as this.

New 6CG7 Won't Work

After trying six or seven new 6CG7 tubes in a horizontal multi-vibrator circuit (Fig. 2), measuring all resistors and substituting for the capacitors, it was decided that somehow this particular circuit was just unstable. A check of the various key waveforms revealed that the signal across the cathode resistor was quite high in comparison to the grid signal on the second stage. Since this could lead to double triggering and the instability we found, the value of the cathode resistor was reduced by about 30% and circuit operation again tested. This slight change made all the difference in the world; the cathode pulse amplitude was reduced and circuit stability was restored. A check of the available service literature on this set revealed that the cathode resistor had been 1500 ohms in the early runs, but had been reduced to 1300 ohms in later runs. Apparently, the factory had experienced trouble with the circuit but hadn't reduced the value of the resistor sufficiently to permit non-selected tube substitution.

Cutting Control Shafts

If you are like I am, even with the shop vise for support, it is almost impossible for you to cut a control shaft to length and not have to finish the job with a file or have the shaft turn up either too long or too short. The Centralab SK-2 Shaft-Kut tool alleviates this condition forever. This tool (Fig. 3) is equipped to handle single controls having a standard 3/8-32 threaded

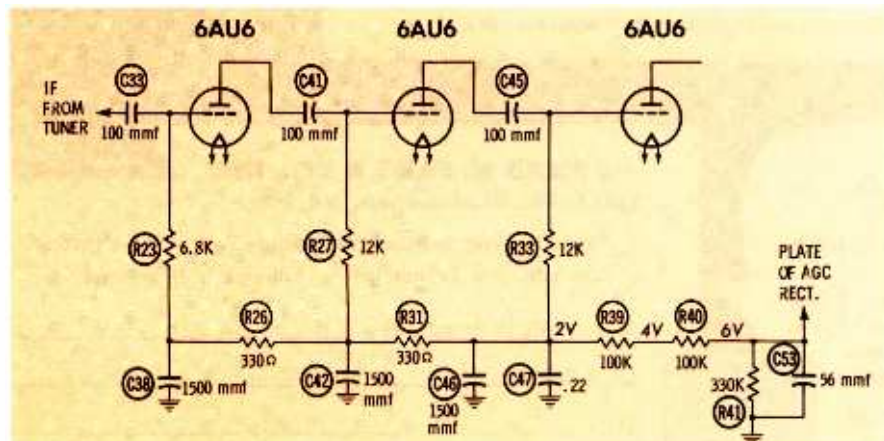

Fig. 1. AGC operation in Philco was upset by three gassy 6AU6 IF tubes.

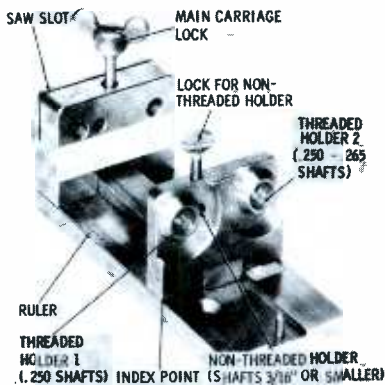

Fig. 3. Model SK-2 Shaft-Kut tool is equipped to handle standard controls.

bushing with either a .250 or .250-.265 shaft diameter, and dual controls (before assembly) if the inner shaft is not larger than about 3/16" in diameter.

The SK-2 is a rugged tool machined from thick blocks of steel. Two countersunk screws are supplied to fasten the SK-2 to the work bench. A built-in ruler enables the user to accurately cut the control shaft to length.

To make sure you cut the new shaft to the correct length, insert a saw blade in the slot as shown in Fig. 4, screw the old control in the appropriate threaded holder; loosen the large wing-nut carriage lock and slide the holder toward the saw slot until the control shaft just touches the saw blade. Now tighten the wing-nut and remove the old control. Install the new control and cut to length.

If you prefer to measure the old control shaft and then cut to length, simply align the index arrow (rear edge of holder assembly) with the desired length on the metal scale and tighten the wing-nut. The control can then be inserted and cut to exact length.

The gummed label (Fig. 3) identifies the correct hole for use with the various Centralab controls. The SK-2 can be used with any control having standard bushings and shaft.

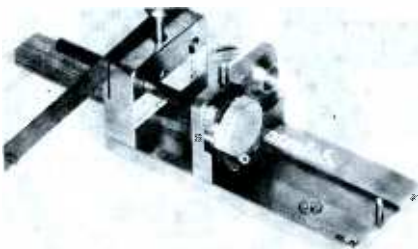

Fig. 4. Using the SK-2 to cut the shaft of a control to the desired length.



"LOOK, BUSTER! ... WHY DON'T YOU GET OFF THAT BEADS AND TRINKETS KICK AND BRING US SOME WEBSTER STEREO-CERAMICS"

Aborigines, audiophiles — everyone would be *demanding* Websters if they knew these Stereo-Ceramics play those cherished 78's, standard LP's and new stereo disks with an *extra* measure of high quality reproduction. So tell 'em and install 'em every chance you get. And be sure you carry a good stock of all Stereo-Ceramics on hand — load up your service kit, too.

Extra profits for you in stereo conversion — check the "Service Center" at your jobber.



SC-3D Stereo turn-under — Frequency response, 30 - 15,000; Output, 0.5V; Compliance, 2x10 cm/dyne; Channel separation, 20 db; Stylus, .7 mil diamond, 3 mil sapphire. \$21.00*



SC-2D Stereo single needle — Frequency response, 30 - 15,000; Output, 0.5V; Compliance, 2x10 cm/dyne; Channel separation, 20 db; Stylus, .7 mil diamond. \$18.50*



MC-2 78 rpm single needle — Frequency response, 30 - 15,000; Output, 0.5V; Compliance, 2x10 cm/dyne; Stylus, 3 mil sapphire. \$7.50*

*List price complete with bracket — standard discounts apply

ELECTRONICS DIVISION
WEBSTER ELECTRIC
RACINE · WIS

our 50th year

Franklin adv. Y-135

"Servicing Transistor Radios"... New Vol. 3



Complete analysis of 64 popular transistor model radios produced in 1958-59...

PLUS SPECIAL "Techniques in Servicing Transistor Circuits"

You'll save time, you'll earn more on Transistor Radio repairs with this complete data on 64 models produced in 1958-59. Based on actual lab analysis of each set. You get the famous Sams Standard Notation schematics; full photo views of each chassis; complete alignment data; full parts replacement information—everything you need to be successful in fast-growing transistorized radio servicing. Includes valuable section on special techniques for servicing transistor circuits. Has cumulative index covering Vols. 1, 2 & 3. It's a "must" for your bench. 160 p., 8½ x 11". Order now! Only. **\$2.95**

IMPORTANT NEW SAMS BOOKS



"101 Ways to Use Your VOM and VTVM"



Bob Middleton's latest book in this famous series... so practical and useful it belongs in the library of anyone who owns these important instruments...

A complete and practical guide to the fullest use of VOM's and VTVM's. Describes equipment checks; DC voltage tests; ohmmeter tests; signal-tracing tests; AC voltage tests; DC current tests; alignment applications; Color TV tests. Each application is covered concisely, with full data on equipment needed, connections required, proper test procedure and evaluation of results. Includes valuable special notes supplementing uses described. Over 150 illustrations; 116 pages; 5½ x 8½". Invaluable for technicians, engineers and students. **\$2.00** Only.

HOWARD W. SAMS & CO., INC.

Order from your Sams Distributor today or mail to Howard W. Sams & Co., Inc., Dept. GG-39 2201 E. 46th St., Indianapolis 6, Ind.

Send me the following books:

- "Servicing Transistor Radios" Vol. 3 (TSM-3).
 "101 Ways to Use Your VOM & VTVM" (TEM-3).

\$_____ enclosed. Send Free Book List.

Name _____

Address _____

City _____ Zone _____ State _____

(outside U.S.A. priced slightly higher)

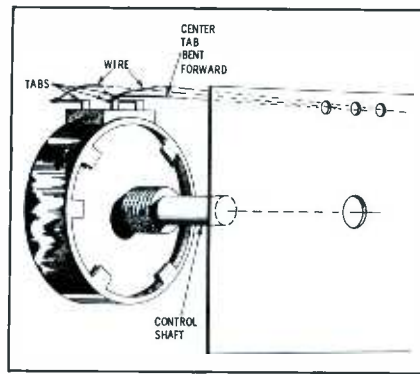

Fig. 5. How to prepare and install a 2-watt control in CTC-7 focus network.

To cut rear control shafts of dual units other than Centralab (3/16" shaft diameter), mark the shaft at the point corresponding to the rear edge of the mounting bushing. This point is then aligned with the rear edge of the control holder and cut to the desired length as indicated on the metal scale. Be sure to allow for projection beyond the outer shaft. With a little practice, you can cut any shaft to length in less time than it takes to tell about it.

Focus Control for RCA CTC-7

Even though I suspected the focus control was defective, I installed a new 1V2 and adjusted the focus pot on the initial call to cure the customer's complaint about a fuzzy picture. Sure enough, the customer called again the next day complaining that the same trouble had come back. Because I had heard this chassis was "death on focus pots," I decided to try and install a unit with a higher wattage rating rather than another one-watt factory unit. Consulting various catalog data, it was found that both Clarostat type 53 and Ohmite type AB controls (both two-watt plastic-element sealed controls) were available at 100,000 ohms with linear taper.

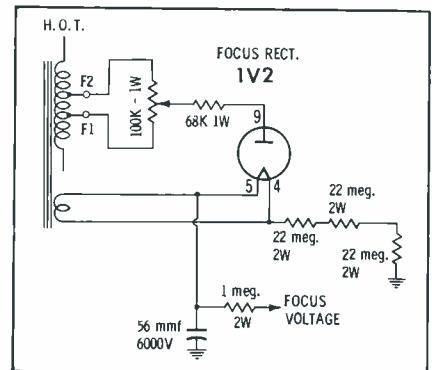

Fig. 6. Off-value 22-meg resistor shifts proper focus point to one end of control.

Further, these controls were small enough to fit in the required space. The final consideration was whether or not the terminals on the control would pass through the mounting board and connect to the circuit. By bending the center lug forward and attaching a 1" length of bare wire to the end terminals (Fig. 5), this problem was solved. To guard against arcing and corona, the three terminals and the lengths of bare wire were painted with red corona dope.

After the corona dope had completely dried, the receiver was turned on and the focus control adjusted for proper focus. Power was removed and the resistance between the center arm and each end terminal was measured. This check revealed that the control was set near one end of its rotation to obtain best focus. Since this left very little latitude for later adjustments, the circuit (Fig. 6) was checked for defects. All resistors except one of the 22-meg units checked within tolerance. Replacement of the off-value resistor restored the circuit to correct balance, and best focus was then obtained with the focus control adjusted near the center of its rotation.

SENCORE "Fuse Safe" CIRCUIT TESTER

Save Time with SENCORE

Save costly call backs by testing the circuit before replacing fuse, fuse resistor or circuit breaker.

Individual scale for each value fuse resistor—no interpretation, just read in red or green area.

- ★ Measures line current and up to 1100 watts of power at 115 volts using line cord and socket. ★ Two convenient current ranges—0 to 2 amps and 0 to 10 amps. Test leads clip in place of fuse or fuse resistor. ★ 5 ohm, 10 watt resistor prevents TV circuit damage, simulates operating conditions.



As Recommended by Leading Manufacturers

Service Instruments Corp., 121 Official Rd., Addison, Ill.

See other SENCORE ads in this issue



\$8.95 DEALER NET

AC-DC or both as needed for Fuse Resistor Circuits

At Leading Parts Distributors

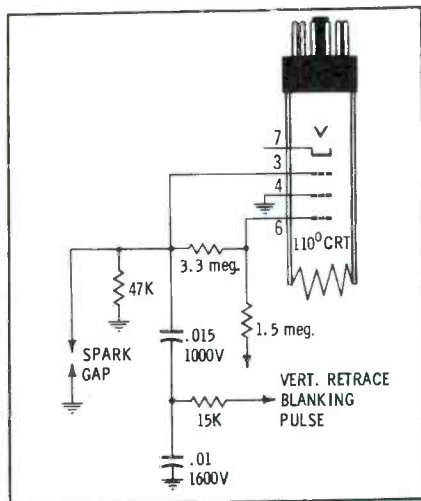

Fig. 7. Picture tube network in GE M4 and M5 chassis features "spark-gap."

"Spark-Gap" for G-E M4 and M5 Chassis

Some early production M4 chassis were troubled by failure of the .01-mfd, 1600-volt capacitor and 15K-ohm resistor in the vertical retrace blanking network (see Fig. 7). Investigation proved that the capacitor was shorting and causing the resistor to burn. The reason for the capacitor's failure was traced to arcing within the picture tube. Two steps were taken to eliminate this condition. The first consisted of altering picture-tube design so that best focus would be obtained with the focus anode grounded. This helped provide an arc path to ground, and minimized the effect of internal tube arcing. The second step was to install a "spark gap" (Fig. 8) between the accelerating anode and ground. In the "M4" chassis, this unit was physically installed at the picture-tube base. If you should replace the CRT in one of these chassis, be sure to reinstall the "spark gap." Failure to do so could result in the premature failure of the new tube. In the "M5" chassis, the spark gap (still connected between the accelerating anode and ground) is soldered to the printed circuit board used in the sweep section. ▲

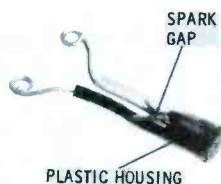

Fig. 8. Spark-gap consists of two wires held in place by plastic molding.

THE TREASURE CHEST THAT'S NEVER EMPTY



FILLED WITH "GOOD-AS-GOLD" C-D CAPACITORS.

Here's the smart, modern way to keep your working capacitor stock shipshape. Each chest comes with a fast-moving assortment of C-D "Preferred" type twist-prongs, "Blue Beavers," and Mylar Tubulars—buy them and you get the chests FREE. Speed up your work...establish customer confidence with Consistently Dependable C-D capacitors from your own Treasure Chests. See them at your distributor or write for Bulletin to Cornell-Dubilier Electric Corporation, South Plainfield, New Jersey.



Consistently Dependable
CORNELL-DUBILIER
SERVICE CAPACITORS

Servicing Electronic Organs

By Jack Beaver

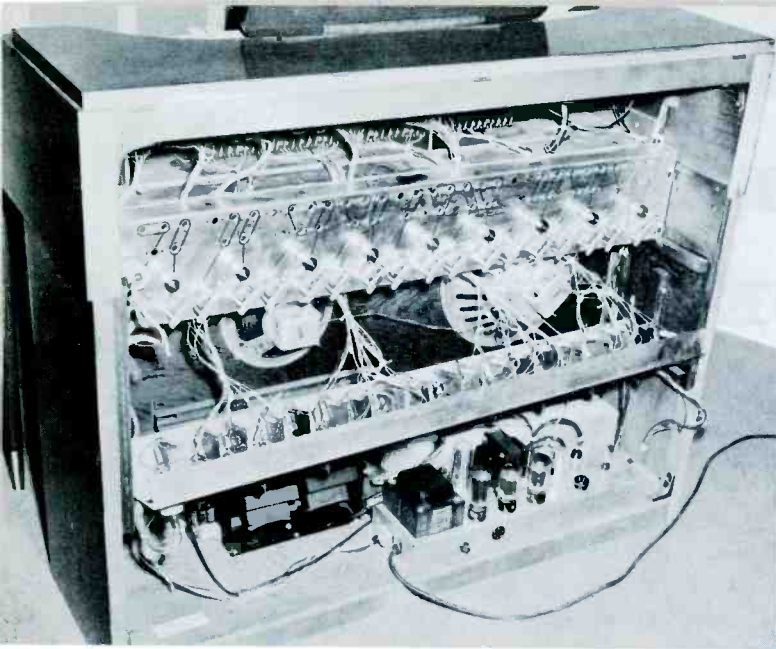

The usual response of an electronic technician when he first views the interior of an electronic organ is one of dismay, coupled with a sudden impulse to close the box quickly, and quietly go home. The reaction is entirely unjustified—any television set is much more complicated, and TV troubles are infinitely harder to diagnose. Organ troubles are practically self-diagnosing, since every key is a test point for one or more of the tone generators.

General Plan of Organs

The general plan of any electronic organ is quite simple, usually consisting of a series of tone generators, a normal compliment of keyboards, various tone modifying circuits, an audio amplifier, and one or more loudspeakers. Volume is controlled by a foot pedal, known as the *swell*

pedal. Fig. 1 is a partial block diagram of a typical organ, showing only a few keys and tone generators.

The Claviers

Most organs for home use have three sets of keys, two of which are similar to a piano keyboard, and one which is a foot-operated arrangement. The upper of the two hand keyboards, or *claviers*, is the *swell* manual; the lower one is the *great* manual. The foot affair is the *pedal clavier*—and please don't say "pedal manual." This means "foot-hand," and doesn't make much sense. Any keyboard, even the piano's, is a *clavier*. With the exception of the more elaborate organs, the great and swell manuals will have keys for about four octaves, and the pedal clavier for one to two and a fraction octaves. The entire over-all range of

the instrument may be from five to seven or eight octaves.

The lowest range will be the first octave of the pedals. The great manual may extend from the second octave to the fifth or sixth, and the swell from the second or third to the sixth or seventh. Individual models vary in their coverage and flexibility.

Organ Terminology

Some other peculiarities of organ terminology are important. Unlike the pianist, the organist has control of the *octave* in which a given key will play. If he closes an 8' tab on the swell manual, the keys of this manual will play the notes which correspond to the position of the keys in the clavier. If he closes a 4' tab (often called a 4' *rank*), the key will play a note one octave higher. The 16' tab gives him a note an octave lower. In this way, four octaves of keyboard gives him six octaves of notes, and he may play all three notes at once for each key.

A *quint* tab is found on many organs. Depressing it adds a fifth—i.e., the third note of the major triad—to every note played, usually with reduced volume. When playing with this tab depressed, an odd, pleasing effect is noted. *Coupler* tabs are also used sometimes. These have the effect of connecting two keyboards together, usually the great to the swell.

The more elaborate Hammond organs have preset tabs, usually an extension of the keyboard with the key colors reversed. These presets throw in a special setup of tone modification, which otherwise would take the player considerable time to adjust. Hammond also uses an un-

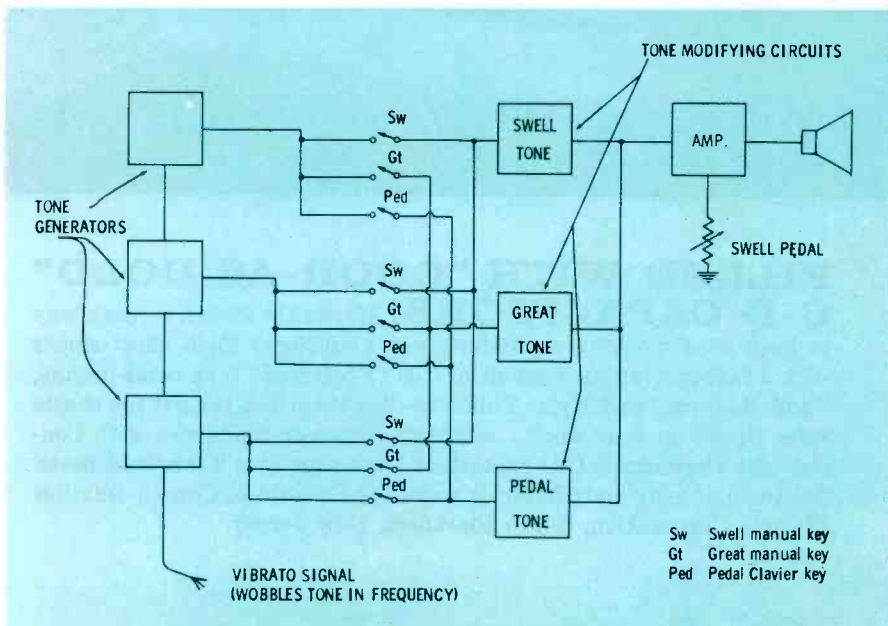

Fig. 1. Partial block diagram of a typical organ shows keys and tone generators.

usual device to produce reverberation, the effect of echos in a large auditorium. This device consists of a series of springs which are excited by a driver unit operating from the amplifier output. The springs "carry over" the notes, which are taken off by a pickup and fed back into the amplifier.

On some organs *attack* and *decay* controls are found. A tone which rises very rapidly to full volume has *fast attack*; a slow rise is *slow attack*. A tone which disappears abruptly when the key is released has no decay. A slow decay is more natural and pleasing for most music. *Echo organ* is usually just a remote speaker. *Vibrato* is found on all electronic organs, but not on pipe organs. This is an effect like a violinist makes when he "waggles" his hand on the violin neck. It consists of varying the pitch of the note smoothly above and below the base frequency at a rate varying from 5 to 8 cycles per second, and is very pleasing.

Tremolo is another term sometimes associated with organs, and is not to be confused with vibrato. Tremolo is a variation in amplitude or volume, at approximately the same rates as the vibrato modulation. In pipe organs, this is performed by a fluctuation of the air pressure feeding the pipes. Electronically, the gain of a buffer amplifier is varied by the same signal which operates the vibrato circuitry. The same circuit has been employed, using a much larger amount of control, to cause a chopped effect, such as is found in the playing of a vibraharp or dulcimer.

Non-Electronic Tone Generators

The greatest difference between various makes of organs is in the design of tone generators. The majority of organs use electronic oscillators with resonant circuits as the frequency determining devices, but two exceptions are found in popular organs. The Hammond organ, called by its makers an "electric" organ, uses discs of magnetic material with serrated edges which spin past magnetic pole pieces to generate tones, somewhat after the fashion of the old type magnetic phonograph pickups. The frequency of the tone is dependent on the number of edge serrations and the speed

Precision cutting... a simple job

with the new

Centralab

SK-2

SHAFT-KUT

TOOL

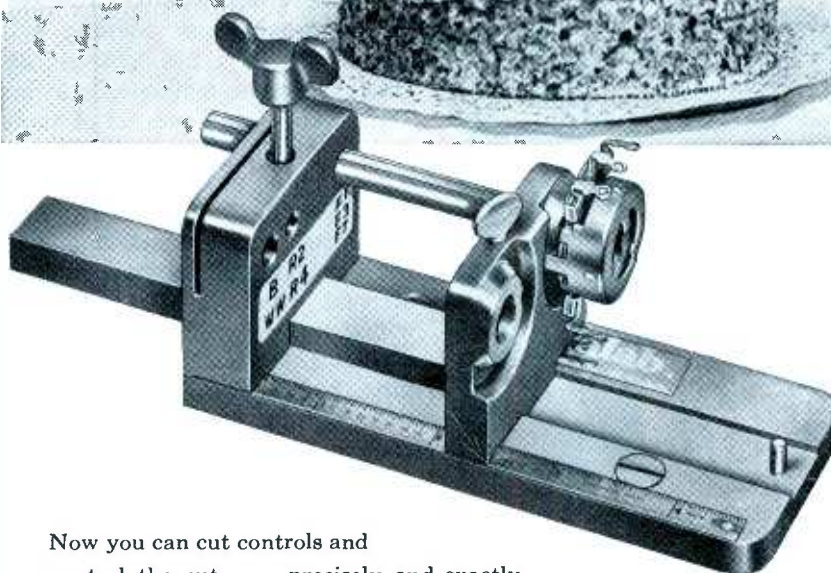
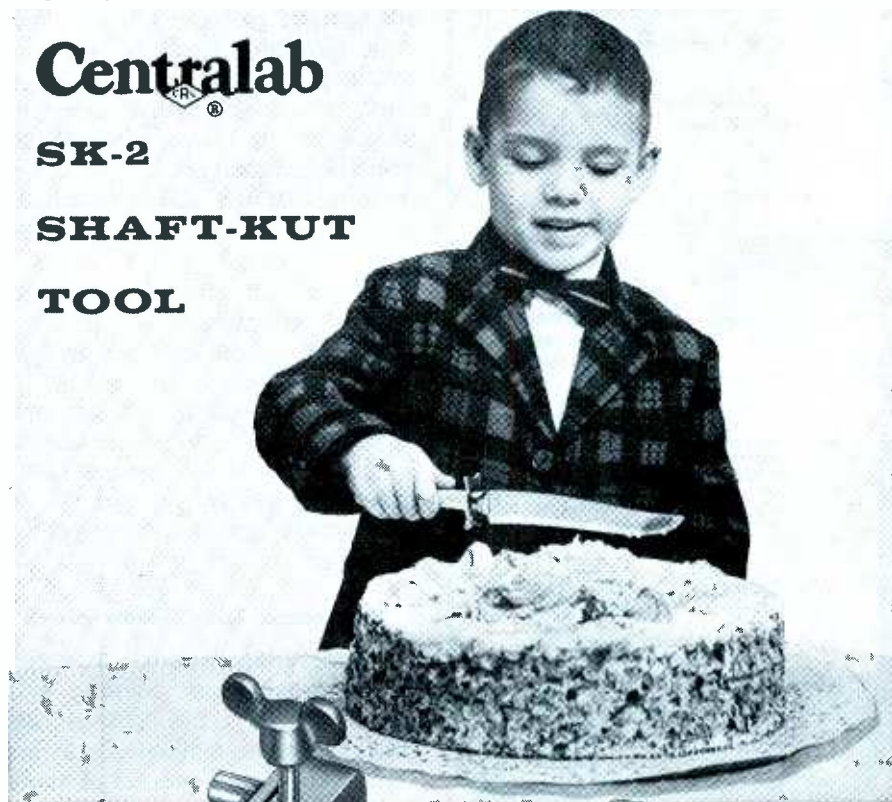

Now you can cut controls and control the cut . . . precisely and exactly.

CENTRALAB's Shaft-Kut Tool is a precision instrument, *guaranteed* to make a really simple job of cutting shafts to the exact size you need.

With this tool you can cut any single or dual control . . . or switch shaft, and get cuts that are accurate to $\frac{1}{64}$ th of an inch! The tool and calibrated jig are made of case hardened tool steel, designed to last a lifetime.

You can't make a wrong cut with the CENTRALAB Shaft-Kut Tool! And the price is less than half what you'd expect to pay for a precision device of this kind . . . a low \$4.95 dealer net. Ask your distributor to show you how easy it is to use this new tool.

Centralab
B-5931 ©

A DIVISION OF GLOBE-UNION, INC.
942G E. KEEFE AVE. • MILWAUKEE 1, WIS.
IN CANADA: 669 Bayview Ave. • Toronto 17, Ont.

**CONTROLS • ROTARY SWITCHES • CERAMIC CAPACITORS
PACKAGED ELECTRONIC CIRCUITS • ENGINEERED CERAMICS**

BERNS PERFECT PIN-CRIMPER

Picture-Tube Repair Tool

Eliminates that hard soldering job.

only \$1.25

Fix loose pin connections in seconds. Pays for itself in time saved on one job alone. 3" long.

Patent 2,878,698

Intermittent operation of picture tubes due to defective solder connections at socket pins is easily corrected through the use of the Berns Perfect Pin Crimper. Actually a 3-in-1 tool that can also be used as a channel-selector wrench and screwdriver, it serves to notch pins and element leads to provide solid electrical connections. Pin keeps its original form.

IT'S DANDY . . . IT'S HANDY
"you'll like it"

Available at your parts distributor.
Another fine product from:

BERNS Mfg. Co.
9853 Chalmers,
Detroit 13, Mich

TARZIAN Offers 48-Hour, Direct Factory Service on Tuner Repairs

only \$7.50



That's right. Net, \$7.50 per unit and \$15 for UV combinations, including ALL replacement parts. 90-day warranty against defective workmanship and parts failure. Tuners repaired on approved, open accounts. Replacements offered at these prices* on tuners not repairable:

- VHF 12 position tuner . . . \$22.00
- VHF 13 or 16 position tuner 23.00
- VHF/UHF combination 25.00
- UHF only 15.50

*Subject to change



Tarzian-made tuners are easily identified by this stamping on the unit. When inquiring about replacements for other than Tarzian-made tuners, always give tube complement . . . shaft length . . . filament voltage . . . series or shunt heater . . . IF frequency and chassis identification. Use this address for fast, 48-hour service:

SARKES TARZIAN, Inc.
Att.: Service Mgr., Tuner Division
East Hillside Drive
Bloomington, Indiana

of rotation. Fig. 2 illustrates the manner in which this is done.

The other major exception to the use of electronic oscillators is in the Wurlitzer organ, which features electrostatic pickup from air-driven reeds like those found in piano accordions. The pickups are ingeniously arranged to get different effects from the same reed. In the Wurlitzer, these reeds are driven continuously in a closed circulating air system, the whole assembly being in a sound-proof chamber.

In both the above organs, tone coloring (changing the overtones or timbre of a given note) is done by synthesis. This is the process of harmonically adding related tones in controlled and varying amounts. Such addition is the function of the tabs on the keyboard panels. In the Hammond, "draw bars" control this function.

Electronic Tone Generators

Organs using electronic tone generators provide tone coloring by a process which is the diametric opposite of the two methods mentioned above. They use a process of analysis, or breaking down, of a very complex tone to simpler tones. The usual starting point is a sawtooth waveform, which contains a great number of harmonics above its fundamental. Many oscillator circuits, including the simple neon relaxation oscillator, provide this output waveform, but all have the same fault—they are not stable in frequency. They do, however, have the saving grace of being very easily synchronized by a triggering voltage, which may be obtained from a stable LC oscillator.

Organ makers take advantage of the harmonic relationship found in music to simplify the design of their instruments. In music, the term "octave," although meaning an interval of eight whole tones, is also used to describe the relationship between two tones, one having twice the frequency of the other (the second harmonic). For instance, the lowest A on the organ has a frequency of 55 cps, the A or the next higher octave will be 110, then 220, 440, 880, 1760 and 3,520 cps. The same relationship holds true between all other notes of the scale, of which there are 12, counting the half-tones (flats and sharps). By making 12

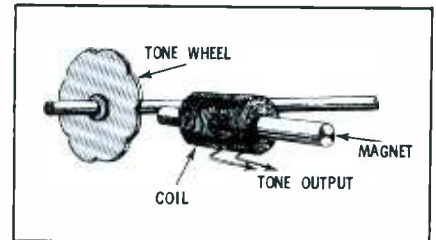

Fig. 2. Example of electro-mechanical generator used by Hammond.

stable oscillators, one for each note on the highest octave to be used, the lower octaves can be generated by a frequency division process using keyed relaxation oscillators.

Such oscillators can be synchronized with a cyclic pulse which is an even number multiple of their normal frequency of oscillation. For instance, if the normal frequency of oscillation is about one-half that of the triggering oscillator, the oscillator will lock in at exactly one-half the frequency, and thus produce a tone one octave lower. (See Fig. 3.) To return to the initial example for the note A, the frequency controlling oscillator T, which is adjustable to allow the organ to be tuned, triggers the relaxation oscillator H, which then produces a sawtooth wave at the same frequency. In turn, oscillator H triggers oscillator I, which responds at half frequency and produces a note an octave lower. Oscillator I triggers J, again dividing the frequency so that the next lower octave note is produced—and so on to the lowest octave. Twelve such chains produce all of the basic tones of the organ.

This is a clear example of what was meant by the statement that

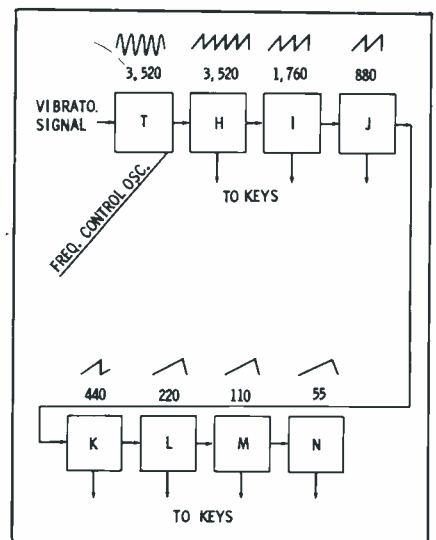

Fig. 3. Block diagram of the oscillator chain for one complete musical note.

organs are self-diagnosing. In this example, suppose that the organ produced badly out-of-tune and wavering notes on all A's. We must assume that the basic frequency-controlling oscillator is not operating properly, probably because of a defective tube. In some organs, the lower-frequency oscillators are one-shot multivibrators, and will not oscillate without triggering. In these cases, any note from the defective oscillator down will not sound.

The vibrato signal being applied to the controlling oscillator in Fig. 3 is a low-frequency sine wave, either impressed on the plate supply to vary the oscillator frequency or else operating a frequency control tube. Usually, there are organ tabs to vary this rate or turn it off.

Keying methods

In practically all organs, the tone generators, regardless of type, are producing signals continuously. These are then keyed into the tone-forming circuits and on to the amplifier by the player's operation of the instrument keys. In more elaborate organs, the keys operate indirectly, being used to "gate" a tube which acts as a buffer between oscillator and amplifier. Such a gated-amplifier tube can be controlled through RC circuits which provide controllable attack and decay.

The outputs, no matter how derived, are fed into buss lines which are common to one particular keyboard, or one tab on the keyboard. These then go to the tone-forming circuits.

Tone Forming Circuits

The raw sawtooth output of the tone generators is a musical tone since it contains many overtones, but it does not have the character or timbre typical of musical instruments or organ pipes. It does, however, contain all the frequencies found in these instruments, the difference being the proportions of harmonics to the fundamental. It is important to note that the tones of musical instruments do not have the same overtone structure for each note of their range. In general, harmonic structure simplifies as frequency increases; some instruments, such as the flute or whistle, producing almost pure sine waves at their highest ranges.

This characteristic allows filters, quite similar to bass and treble boost



Save 35% on Transistors and Diodes With this new kit... from Sylvania

You get seven Sylvania quality semiconductors for the price of four when you buy Sylvania's New Transistor Radio Kit. It contains three audio drivers, type 2N35, three RF-IF amplifiers, type 2N94, and one crystal diode type 1N34. You get all seven units worth \$8.69 at the special kit price of \$5.65—a saving of \$3.04. In addition, you receive at no extra cost a 34-page 35¢ transistor booklet with full information and schematics for 20 practical transistor circuit applications.

Increase replacement profits with two new Diode Kits



Here is how the cost breaks down for this special kit offer:

3—2N35 @ \$1.16	= \$3.48
3—2N94 @ 1.57	= 4.71
1—1N34 @ .50	= .50
Total Regular Cost	\$8.69
Sylvania Kit Price	\$5.65
YOU SAVE	\$3.04

TV-AM-FM Detector Diode Kit—These five Sylvania detector diodes will cover your TV replacement requirements. Includes 2—1N60, 2—1N64 and 1—1N295 plus a specification chart for each type. Regular cost is \$2.35—Now \$2.15.

Universal Diode Kit—Five Sylvania types—1N34A, 1N38A, 1N60, 1N64, 1N82A—to meet 90% of your replacement needs—includes a direct replacement guide. A \$3.50 value for \$2.95.



Order now from your Sylvania Distributor while special kit stocks are still available.

SYLVANIA
Subsidiary of
GENERAL TELEPHONE & ELECTRONICS



Sylvania Electric Products Inc.
Semiconductor Division
100 Sylvan Rd., Woburn, Mass.

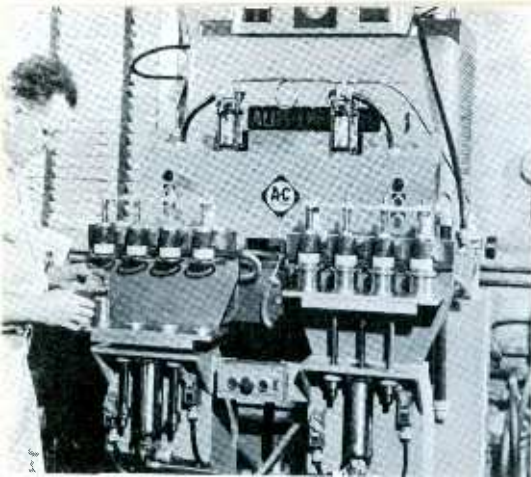

COMING NEXT MONTH

Servicing Industrial Electronics

The above photo is a small preview of the next installment, which describes typical induction-heating units in commercial use.

Bench Servicing New Sets

If you liked the last installment of this series, you won't want to miss this coverage of Sylvania's new "dualette."

Scoping Modern TV Sets

Normal and abnormal scope waveforms to help you quickly isolate troubles in typical late-model TV receiver circuits.

Vertical Sweep Systems

Descriptions of the five basic vertical sweep circuits used in TV receivers, with trouble-symptom analyses tied to component functions and defects.

Previews of New Sets—on new Admiral, Muntz, Trav-Ler, and Westinghouse sets.

Video Speed Servicing—with service hints for Magnavox and Zenith TV receivers.

Quicker Servicing—examples of horizontal multivibrator troubles you may encounter.

Across the Bench—how to use the DC input of a scope to good advantage.

The Troubleshooter — that ever-popular question and answer column on servicing.

Notes on Test Equipment—covering EICO's 1020 power supply and RCA's VTVM kit.

... plus all the other regular PF REPORTER departments.

To enter a new or renewal subscription, simply fill in and mail the coupon below.

Please enter my subscription to PF REPORTER for:

1 Year \$4.00 2 Years \$7.00 3 Years \$9.00

Above rates apply only in U.S.A., its possessions, and Canada. All other countries: 1 year \$5.00, 2 years \$9.00, 3 years \$12.00.

Bill Me Remittance Enclosed
 Extend Present Subscription

Give to your parts distributor or mail to PF REPORTER, 2201 E. 46th St., Indianapolis 6, Ind.

Name _____

Firm _____

Address _____

City _____ Zone _____ State _____

Please Check Your Business Classification

Independent Radio, TV Serviceman Owner, Mgr.
 Retail with Service Department Service Mgr.
 Industrial Electronics Service Employee
 Other (Specify occupation & title) _____

or cut circuits, to modify the sawtooth signals and form remarkably good imitations of pipe-organ and instrument tones, and to have the same property of changing harmonic structure as the tones go to different parts of the instrument's range. The "voices" of the organ—the various tabs labelled by such names as "Dulciana," "violone," "clarinet," "flute," etc., merely cut these filters in and out. Usually, the circuitry is arranged so that adding voices also adds volume. This helps to reproduce the behavior of the pipe organ, which produces these sounds by cutting in entire new ranks of pipes. By the way, the 4', 8' and 16' nomenclature on organs refers to the longest pipe in a given rank among early organ designs, explaining why the 16' voice is an octave lower than the 8', and the 4' an octave higher.

The Amplifier

Organ amplifiers are quite conventional, with the exception of the very heavy filament supply required to operate the 70 to 80 tubes, and the regulated plate supply for the tone generators. Usually, they have audio outputs of at least 30 watts, 6L6's being commonly used in the output stage. Some also incorporate treble cut controls, called "brilliance" controls. The swell pedal, which is simply a foot-operated gain or loudness control, is connected into the amplifiers. It does not return to a complete "off" position, but only to a low level, since "off" is a function of the keys and is not required here. The swell pedal is constructed so that it will hold any given position.

Trouble Analysis

In general, when faced with a non-operative organ, go over the

operation of the organ to determine which musical notes or features are non-functioning. With this information, decide on the section that is bad, then locate it and make confirming tests.

Circuits and parts are conventional, and no special test instruments are needed. One caution—if you have a "tin ear," don't touch tuning adjustments; let an expert organ tuner do it. The frequencies of musical tones are unbelievably accurate; good musicians can tell a difference of 1/2 cycle at 435 cycles, so don't try setting one up with your audio oscillator! Good organ tone generators are stable to 0.1% of true pitch.

Don't be fooled by the fact that the highest frequency note of an organ is less than 5,000 cycles. The amplifier should be flat up to at least 10,000 cycles, because the 5,000-cycle tones are not simple sine waves and contain higher harmonics. Improvements can be made in organ sounds by adapting hi-fi techniques, particularly that of using crossover networks to feed the low tones to good woofers and high tones to good tweeters. Low-frequency pedal notes need plenty of push, and intermodulation distortion detracts considerably from organ tones.

Another thing—don't file contact points on keys and tabs. Use contact cleaner or a point burnisher—never a point file. When setting contact points, be sure that one key does not close with a small movement and the other with a large movement. This distracts organists when playing, since they lose the precision of note attack.

Don't be afraid to get into this field; it's certainly a growing one and not at all crowded. ▲

SAVE TIME with

SENCORE

®

NOW —
Check Vibrators
in ANY
Tube Checker

2 Adaptors in 1

SENCORE

"VIBRA-DAPTOR"

Checks Both Three and Four Prong Vibrators

- Merely plug into any tube checker. Set for 6AX4 (or 6SN7) for 6 Volt Vibrators and 12AX4 (or 12SN7) for 12 Volt Vibrators. • Two lamps viewed through top of adaptor indicate whether or not Vibrator needs replacing. Rugged—Made of steel. • Replaceable but unbreakable #51 indicating Lamps. Operates easily with Sencore LC-3 Leakage Lamps. Operates easily with Sencore LC-3 Leakage Checker. Complete instructions screened on front.

In stock at your local parts distributor.
Service Instrument Corp., 121 Official Road, Addison, Ill.

MODEL VB-1
\$275
DEALER NET

See other SENCORE ads in this issue.

Letters

(Continued from page 12)

our other readers phone for help. Answering the hundreds of letters we get every month asking for servicing help puts us on the firing line to a certain degree. Asking us to come up with the right answer seconds after the telephone rings is like asking us to look down the rifle barrel.—Ed.

Dear Editor:

An item in the May *Dollar & Sense Servicing* column, entitled "Calculated Risk", states, "If you'd rather take a firmer approach to the credit situation, visit a lawyer and have him draw up a simple chattel mortgage to be printed on the back of the service ticket."

There's a simple method available to any service dealer. Dave Rice's Official Order Books (as advertised on page 40 of the same issue) includes a promissory note already printed on the form.

LAURENCE KAUFMAN

Stral Advertising Agency
Chicago, Ill.

Thanks, Larry. We didn't think to check this point. At least one other supplier of service forms has something like this, too.—Ed.

Dear Editor:

I agree with your reply to Stanley Anderson's grievance (May "Letters") concerning the format of PF REPORTER.

WOW! I hate to think what the magazine would cost us if it weren't for the advertising. Placing it where it will be noticed helps us, too.

RAYMOND OGLE

Sacramento, Calif.

Go to the head of the class, Ray—it's evident you're really aware of how wonderful and informative good advertising can be, and how much it would be missed by most people if there were none. Speaking of good advertising, it's a pleasure to pat our ad department on the back (for a change) for their refusal to accept surplus and other "cheap-type" advertising in PF REPORTER.—Ed.

Dear Editor:

I enjoy PF REPORTER very much and find it is a great help.

Last week I serviced a set for a customer whose late husband was a TV serviceman. She gave me back copies of PF REPORTER for the years 1954 through 1957. I consider myself fortunate indeed to acquire this valuable literature, and I intend to read and study as many articles as time will permit.

Are *Video Speed Servicing* data sheets available in book form?

GEORGE S. PRIDMORE

Birmingham, Ala.

Hold on to those issues, George—many are no longer available at any price.

Two volumes of "Video Speed Servicing" have been published, and a third is scheduled for publication late this summer. Vol. I is priced at \$4.95, and Vol. II at \$2.95.—Ed.



ELMENCO

DIPPED MYLAR* - PAPER CAPACITORS
MINIATURIZED ±10% TOLERANCE

designed to
withstand
4 times
more humidity
than the best molded capacitors
used in the past!



MINIATURIZED
50% Smaller than other brands

- RELIABILITY that meets computer and missile requirements
- CONSTANT HIGH TEMPERATURE OPERATION at 110°C at full rated voltage
- LONG TERM STABILITY... no drift, no shift
- HIGHER INSULATION RESISTANCE
- ALL VALUES ±10% TOLERANCE
- PRINTED CIRCUIT and TRANSISTOR application

ask for the ARCO

dp "5 PAK"

at your distributor

Each value individually packed
5 capacitors to a "5 Pak"
in a moisture proof transparent bag
for easier handling.

For complete information write for bulletin A5P



*DuPont Trademark



ARCO electronics inc.

64 White Street, New York 13, New York

Branches: Dallas 19 • Los Angeles 35



THE TROUBLESHOOTER

ANSWERS YOUR SERVICE PROBLEMS

Bent Double

The raster on a Hoffman Chassis 211 is greatly compressed in the vertical direction. Depending on contrast setting, it fills only a quarter to a half of the screen. A clear portion of the picture appears to lie directly on top of an inverted, dimmer portion. When the vertical hold control is turned, one section of the picture moves up while the other section goes down.

The plate voltage of the vertical oscillator is very low. If the height control is adjusted in an attempt to raise this voltage, the boost supply becomes weakened as though overloaded; in addition, the height control gets hot.

Scope readings in the vertical circuit are so jittery and unstable as to render them useless.

CARROLL HOLT

Groves, Texas

Look for a short in the vertical circuit. The first components I would check are the ones in the cathode circuit of the output tube—especially C2C and C59. A short here would cause you to lose cathode bias; as a consequence, the output tube would draw considerable grid current during the latter part of each vertical field. This would greatly reduce the grid voltage of the output tube and hence the plate voltage of the oscillator. What's more, it would drive the output tube into saturation and cause the bottom of the raster to be folded over.

There's one thing that bothers me

about this explanation, through: Foldover due to the above-mentioned cause isn't usually as you have described. For this reason, we'd better consider some other possibilities.

Maybe there is leakage in C57, one of the capacitors which develops the drive signal. This fault could lower the oscillator plate voltage by providing a DC leakage path through the low resistance of R65 and R66, and it could also affect the drive signal enough to cause a badly distorted raster.

One thing more—do you suppose the vertical oscillator is trying to run at 120 cps, or double the normal frequency? This possibility is at least worth exploring, in view of the fact that you have two overlapping raster sections of more-or-less equal size. No telling how badly the raster would be distorted if the oscillator were this far off frequency! A 120-cps sweep rate wouldn't give C57 and C58 much time to charge, so the raster height and average oscillator plate voltage would naturally be lower than usual.

The major frequency-determining components are all in the grid circuit of the oscillator. (Note that the integrator in this set is a vital part of the grid network!) Don't give up on this set before you check all these capacitors and resistors for value as well as quality.

Transistor Cookery

I am having trouble with a Mercury Model 84BM auto radio. The original

output transistor was shorted between emitter and collector, and the bias control was burned out. After these parts were replaced, the receiver operated for about three hours; then the output transformer began to overheat. A check of the transistor showed a short between collector and emitter.

RALPH MERTZ

St. Louis, Mo.

The original trouble was apparently in the base circuit. If the base had ever been shorted to ground, almost the entire "A" supply voltage would have been applied across a portion of the bias control—sufficient reason for it to burn out! In addition, the transistor would have been shorted as a result of a tremendous increase in forward bias.

Another possibility is that the bias control had too much resistance, either because of a defect or because it was set incorrectly. This would have allowed too much bias voltage to be developed between base and emitter. The collector current would then have risen to a dangerously high level, sooner or later causing a short in the transistor. As one possible explanation of why the bias control also burned out at this time, the transistor's base might have shorted to the collector and provided a low-resistance path across the "A" supply through the control.

A short in the speaker system could also have caused failure of the transistor (by removing its load), but I have an idea that base-circuit trouble is more likely.

Therefore, I'd advise checking one of these two possible conditions:

1. There is still a partial short in the base circuit.
2. The bias control is set for too much resistance. To adjust it correctly, first turn it to the minimum-resistance position. (This corresponds to minimum forward bias and thus to minimum collector current.) Then insert a milliammeter in series with the collector lead, power the receiver from a 14.4-volt DC supply, and advance the control until collector current reaches 760 ma.

For most efficient operation, coat the transistor-insulating washer with silicone grease and then tighten the transistor securely to the heat sink on which it is mounted.

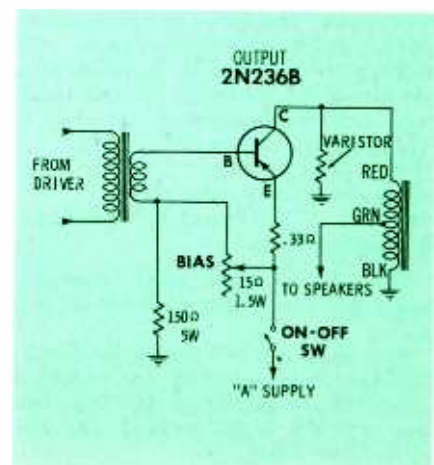
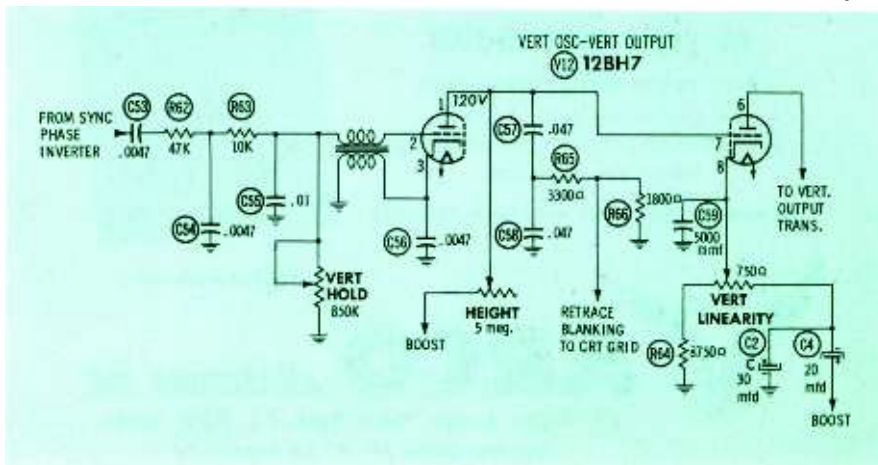

P's & Q's

(Continued from page 31)

ter would rise to the level of the base because of low internal base-emitter impedance, and the collector voltage would decrease to zero since the transistor isn't conducting.

In the case of the NPN unit, the emitter would again assume the same voltage as the base; however, the collector would now rise to the level of the DC source because of non-conduction by the transistor.

An open collector-circuit component in the PNP circuit shown in Fig. 10 causes collector-emitter current to cease. This causes emitter voltage to rise; consequently, the base voltage rises. This increase of voltage will be small since base-emitter current stabilizes the emitter voltage. However, the floating collector rises to the level of the emitter, furnishing the real clue that the collector circuit is open. In the NPN circuit, an open collector-circuit component disconnects the collector-emitter circuit from the power source, causing collector-emitter current to drop to zero. When this happens, the emitter voltage drops to a very low value. The base voltage likewise drops to maintain the base-emitter voltage relationship. The floating collector drops from the original 8-volt level to the emitter level, or to about .1 volt.

How AGC Works in Transistor Circuits

If the IF circuit of the transistor unit to be controlled employs PNP transistors, the circuit shown in Fig. 11 will most often be used. Since the collector of this PNP unit is operated at about -8 volts, correct forward bias (base-emitter) is obtained by connecting the base circuit to the negative supply via a high-resistance path, and connecting the emitter through a suitable resistance to ground. Base-emitter current thereby establishes the emitter voltage at about .1 or .2 volt positive with respect to the base. To reduce the gain of the IF stage, it is necessary to lower the base voltage—shifting it toward zero or in a positive direction.

When the anode of the rectifier is driven positive by the signal, the diode conducts and develops a voltage drop across the volume control (detector load) in the polarity shown. This positive-going voltage

best buys in custom hi-fi... **EICO**

- praised by the experts
- beautifully styled
- priced right for you
- lifetime guarantee



FM Tuner HFT90
with precision "eye-ronic" tuning
Wired \$65.95* Kit \$39.95*
Cover \$3.95.
*Less Cover, FET included
"One of the best buys you can get."—AUDIOCRAFT.

AM Tuner HFT94
with precision "eye-ronic" tuning
Wired \$65.95. Kit \$39.95.
Includes Cover & F.E.T.



STEREO Dual Amplifier-Preamplifier HF81
Wired \$109.95 Kit \$69.95
"Excellent"—SATURDAY REVIEW; and HI-FI MUSIC AT HOME.



STEREO Dual Preamplifier HF85
Wired \$64.95 Kit \$39.95



STEREO Dual Power Amplifier HF86
Wired \$74.95. Kit \$43.95.

Omni-directional Speaker System HFS2
completely factory-built: 36" h, 15 1/4" w, 11 1/2" d.
Mahogany or Walnut \$139.95. Blonde \$144.95
"Eminently musical"—HIGH FIDELITY
"Fine for stereo"—MODERN HI-FI

Also: **Bookshelf 2-Way Speaker System HFS1**
complete with factory-built cabinet, \$39.95

Plus: POWER AMPLIFIERS (14, 22, 30, 35, 50 and 60-watts) from \$23.50.
INTEGRATED AMPLIFIERS (12, 20, 32 and 50 watts) from \$34.95.



best buys in test instruments... **EICO**



COLOR & Monochrome DC to 5 MC Lab & TV 5" Oscilloscope #460
Wired \$129.50
Kit \$79.95



TV-FM Sweep Generator & Marker #368
Wired \$119.95
Kit \$69.95



DYNAMIC CONDUCTANCE Tube & Transistor Tester #666
Wired \$109.95
Kit \$69.95

IN STOCK at over 2000 neighborhood distributors coast to coast
Send for free catalog



PEAK-to-PEAK VTVM #232 & Unit-Probe
Wired \$49.95
Kit \$29.95
(PAT. PEND.)

EICO, 33-00 Northern Blvd., L. I. C. 1, N. Y. PF-7
Show me how to save 50% on top-quality: Hi-Fi
 Test Instruments Ham Gear. Send free catalog and name of neighborhood EICO supplier.

NAME _____
ADDRESS _____
CITY _____ ZONE _____ STATE _____

ADD 5% IN THE WEST

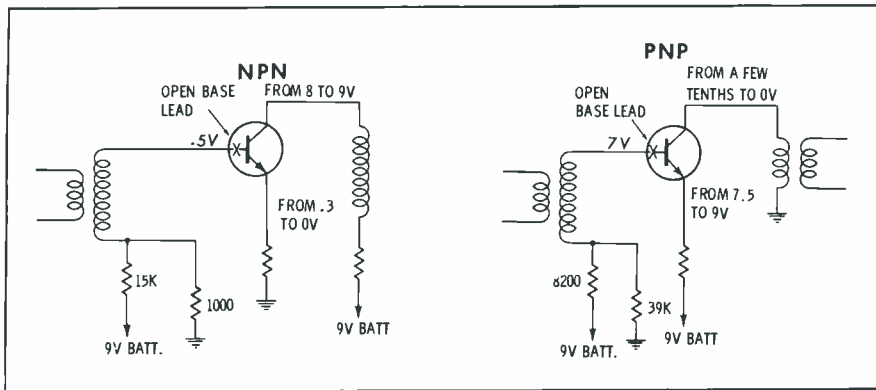

Fig. 7. Open base leads in NPN and PNP circuits result in entirely different sets of voltage readings because of the difference in power-supply polarities.

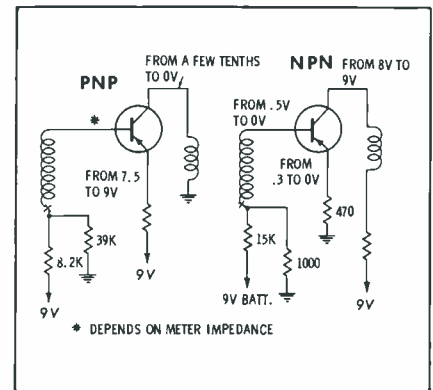

Fig. 8. Open base circuit component causes the indicated voltage changes.

These STANCOR girls protect you by testing every yoke

This is part of the yoke testing department at Chicago Standard. Here every yoke is tested in an actual operating sweep circuit to assure you of trouble-free no-callback performance.

This is just one of the many steps in the thorough STANCOR testing process. Each yoke is breakdown tested at a minimum of twice its normal operating voltage . . . and also gets a complete mechanical and physical inspection.

For your further protection, STANCOR yokes are cosine wound to shape on specially designed forms. You don't have to worry about undue strains and weak spots in the coils—these only occur in yokes where the coils are bent after winding, never in STANCOR yokes.

Have you read "Stan Cor's Corner," a new publication of service tips and other useful information? Ask your distributor for your free copy.



CHICAGO STANDARD TRANSFORMER CORPORATION
3503 WEST ADDISON STREET • CHICAGO 18, ILLINOIS

subtracts from the negative voltage at the junction of the 150K- and 10K-ohm resistors. As the signal increases at the anode of the diode, so does the conduction of the diode and the resultant positive voltage across the volume control. This increase in positive voltage subtracts from the IF transistor's base voltage, thus reducing its forward bias and lowering stage gain.

The 10K-ohm resistor provides isolation between the detector and IF circuits. AGC filtering is provided by the 8-mfd capacitor, which is connected as shown because the base of the IF transistor in this circuit is always negative. Even though the AGC uses a positive-going voltage, it never drives the base positive with respect to ground.

An IF circuit featuring an NPN transistor and positive supply voltage generally uses the AGC circuit shown in Fig. 12. In order to reduce the gain of the IF transistors, the base voltage must be shifted toward zero. Since the required base voltage (slightly positive) is supplied from the 9-volt DC supply through the 47K-ohm resistor, the detector diode is connected to produce a negative-going change with an increase in signal strength as indicated by the polarity symbols in Fig. 12. This negative change opposes the positive voltage coupled to the base circuit via the 47K-ohm resistor, and the conditions for AGC are maintained.

PNP Circuit AGC Supplied By Transistor

The production of the actual AGC voltage is the only difference we shall consider, since the principles governing AGC action are identical. When the signal on the base of the detector transistor goes

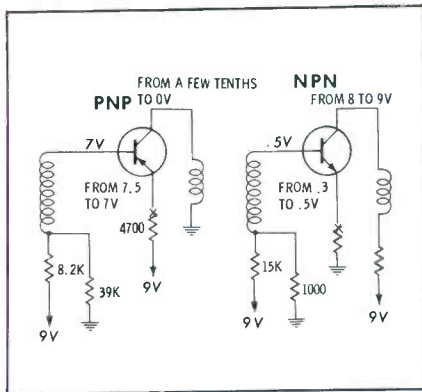

Fig. 9. An open emitter circuit is indicated by a rise in emitter voltage.

in a negative direction, the forward bias on the transistor is increased, resulting in greater collector-emitter conduction and a voltage drop across the 1K-ohm resistor between the collector and the DC supply in the polarity shown in Fig. 13. This positive-going change shifts the base voltage of the controlled IF stage toward zero and reduces IF gain.

**NPN Circuit AGC
Supplied By Transistor**

The circuit in Fig. 14 is a little different from its diode equivalent, since AGC voltage is actually applied to the emitters of the IF stages rather than to their bases. When the base of the detector transistor is driven more positive, forward bias (base-emitter) is increased. This causes the collector-emitter current in the detector transistor to increase. Since this current flows through the 1K-ohm emitter resistors in the IF stages, a voltage drop in the polarity shown is produced. This shift of the emitter voltage in a positive direction reduces the forward bias on the IF transistors, and therefore reduces IF gain.

Testing Transistors

About the best method which can be used to tell whether a transistor or a circuit component is at fault consists of shorting between base and emitter and noting the resultant collector-voltage change. If the transistor is good, this will cause the collector voltage to drop to zero (if this element is returned to ground) or rise to the value of the DC supply (if the collector circuit returns to the ungrounded side of the voltage source). This happens because shorting the base to the emitter removes the forward bias from the transistor and causes collector-emitter current to cease. *Warning? DO*

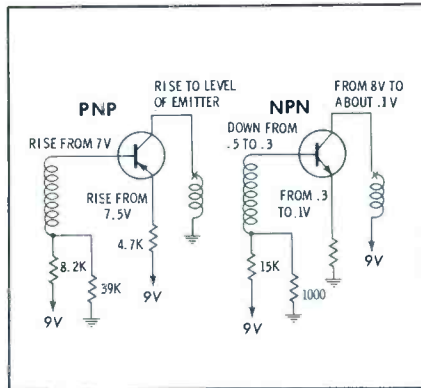

Fig. 10. Open collector circuit causes the indicated changes in voltages.

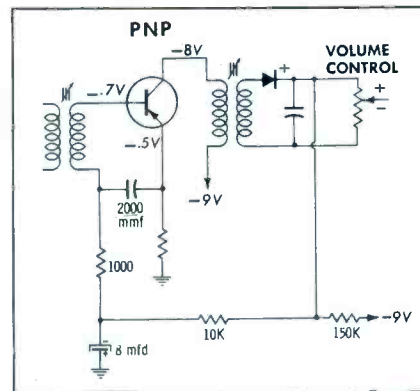

Fig. 11. Diode AGC circuit produces a positive change for PNP transistors.



FOR YOUR WORKSHOP

New electrical outlet convenience

Electrostrip

"4-FOOTER" KIT PATENTED [®] **\$2.95** ➔

Only five minutes to install . . . then a twist of the wrist puts an electrical outlet right where you want it on Electrostrip! Here is ideal electrical convenience for your shop and for your displays. Electrostrip is the ideal solution to the problem of extra outlets in limited space . . . eliminates extension cords and "octopus" plugs. The "4-footer" Kit comes complete with 3 twist-in receptacle plugs, necessary screws, and handy polarized plug-in connector.

Write us for details on the Electrostrip "4-Footer" Kit, the "15-Footer" Kit, or the bulk rolls. Electrostrip is listed by Underwriters' Laboratories.



BULLDOG ELECTRIC PRODUCTS DIVISION
I-T-E CIRCUIT BREAKER COMPANY
 BOX 177 • DETROIT 32, MICHIGAN

In Canada: 80 Clayson Rd., Toronto 15, Ont. Export Division: 13 East 40th St., New York 16, N.Y.



FOR YOUR DISPLAYS



REPLACEMENT SPEAKERS

Stick with the "man who brings" you... order replacement speakers and specify OXFORD... the world's largest producers of SPEAKERS. Our seven factories are supplying the majority of original equipment manufacturers, assures you of exact replacements.

Leading distributors carry OXFORD... so should you.
OXFORD COMPONENTS, INC.
 556 West Monroe Street
 Chicago 6, Illinois
 Export: Roburn Agencies, New York • In Canada: Atlas Radio, Toronto
 BRANDS: Supreme Transformers, Hudson Lamps, Tempo Hi-Fi, Oxford Speakers & Rear Deck Kits.



SAMS PHOTOFAC INDEX



sent direct to your shop
FREE
 SEND FOR IT!

Yes, now you can have the valuable SAMS MASTER INDEX to PHOTOFAC FOLDERS and Index Supplements sent direct to your shop at no cost to you! Just mail coupon below and you'll be sure to receive regularly your handy guide to the world's finest service data covering over 33,000 TV, Radio, Amplifier, Tuner Tape Recorder and Changer models. Send for it—it's FREE!

MAIL COUPON

Howard W. Sams & Co., Inc.
 2201 East 46th St., Indianapolis 6, Ind.

Put me on your mailing list to receive the Sams Photofact Master Index and Supplements

I'm a Service Technician: _____ full time; _____ part time

My Distributor is: _____

Shop Name: _____

Attn: _____

Address: _____

City _____ Zone _____ State _____

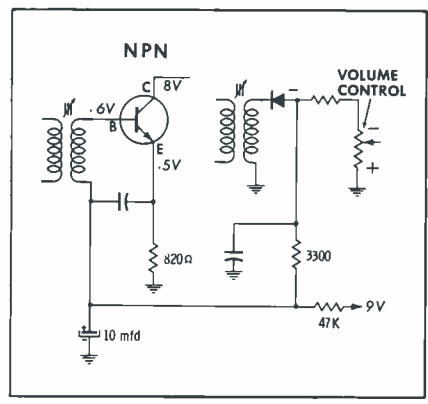

Fig. 12. Diode AGC circuit produces a negative change for NPN transistors.

NOT short the base to ground. This may cause a great increase in forward bias and thus quickly ruin the transistor.

After completely removing any suspected transistors from the circuit, further tests should be conducted to make sure the transistor is defective and to determine how and why it failed. If a transistor tester is available, check the suspected transistor for shorts, leakage, and current gain. Shorts or leakage are the most probable cause of incorrect transistor operation; however, open leads within transistors (indicated by zero gain) are not uncommon.

Even if a suitable transistor tester isn't available, a transistor can be checked for shorts and leakage. Testing involves a resistance check between base and emitter, and then between base and collector using the following procedure:

First, set the ohmmeter to the R x 100 scale and note the scale reading obtained between base and emitter. Now, reverse the meter leads and again note the reading. In one test, the meter should read near the high end of the scale. In the other

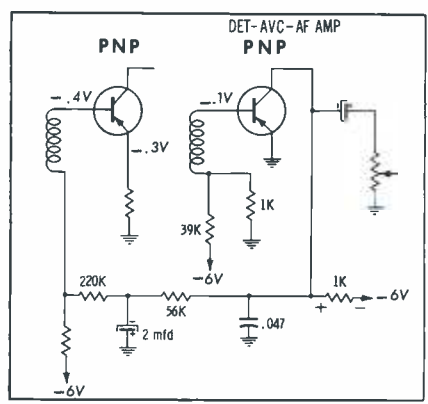

Fig. 13. PNP detector transistor produces positive change for PNP IF units.

test, the meter should read below half scale. Repeat the test procedure between the base and collector; the results should be the same.

Collector-to-emitter leakage can also be checked using the R x 100 ohmmeter circuit. Check scale readings between the collector and emitter terminals in both directions. RF, IF and converter transistors should measure at least 5,000 ohms in either direction. Audio power transistors can read lower but should be at least 1,000 ohms in the lowest direction. For the leakage test, the base lead is left open. Be sure not to use a meter range higher than R x 100. Since some meters use a higher battery voltage on the higher resistance ranges, excess voltage could be applied to the transistor and cause its failure.

Notes on Transistor-Type Usage Chart

Some of the most popular transistor types used by different manufacturers for radio applications are given in the chart at the beginning of this article. Many of these types have been supplied as original equipment in a number of radios, and you can expect to encounter

SENCORE

LEAKAGE CHECKER

Check these outstanding New Features

Save Time with



The LC3 provides all these new improved features in addition to those employed in earlier leakage or "grid circuit" testers. A must for any TV service technician.

- ★ Checks 156 different tube types—more than any other "grid circuit" type checker. Includes UHF and latest type tubes.
- ★ Checks picture tubes without removing tube from cabinet or chassis.
- ★ New Roll Chart prevents obsolescence—just dial the tube type and save time. Chart is easily replaced at no extra cost.
- ★ Provides instant filament checks on "F3-Check" position—no need to carry a second filament checker.
- ★ Capacitor checks simplified.
- ★ Two spare preheating sockets to cut down testing time.

In stock at your local parts distributor.

Model LC-3
\$28⁹⁵

DEALER NET
 Really Whips
 Tough Dogs

Service Instruments Corp., 121 Official Road, Addison, Ill.

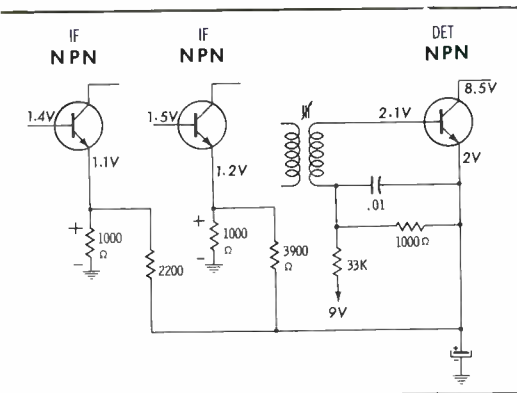
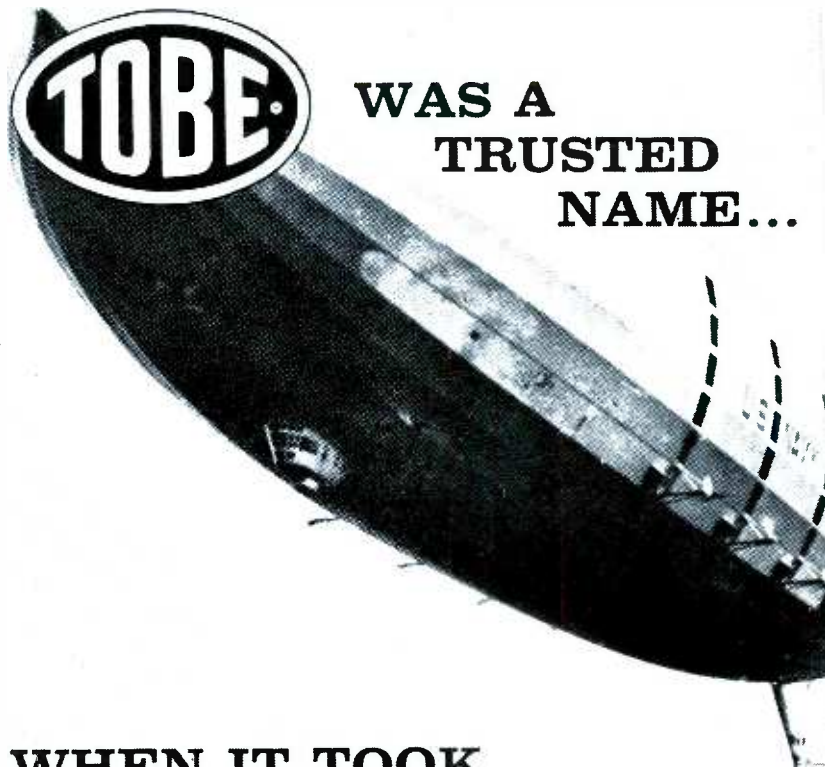

Fig. 14. NPN detector transistor applies positive change to NPN emitter.

them fairly often in the field. You might choose from among these are many instances where one of these types will work in place of another. However, complete interchangeability cannot be guaranteed. If you are forced to find a substitute for a transistor which is obsolete or otherwise unobtainable, it will be necessary to experiment. Before trying any substitutions, check published data to make sure that the maximum ratings of the type you wish to use won't be exceeded in the intended circuit application.

You can expect one of the following results when substituting transistors:

1. Stage gain will be less than it was originally, indicating that the substitute type is not "hot" enough for the circuit concerned, or that it has different internal capacitance which detunes the stage. (The latter effect applies to RF-IF circuits only.)
2. The circuit will break into regeneration, indicating that the transistor provides too much current gain for the application. This is much less of a problem for audio types than for RF-IF types.
3. The new transistor provides normal operation of the stage. In this case, you can probably use it as a substitute for the original unit. Before you consider the repair finished, however, it is advisable to test the receiver thoroughly to be sure the new transistor is doing the job it should and will not break down or otherwise cause performance to diminish within an unduly short period. ▲



WAS A
TRUSTED
NAME...

WHEN IT TOOK
72 HOURS
TO FLY
CROSS COUNTRY

Back in 1924, when it took the dirigible *Shenandoah* 72 hours to fly from Lakehurst, N. J. to San Diego, TOBE had already built a reputation for dependable replacement capacitors. Today, Boeing 707's cross the continent in 5½ hours (and TOBE makes thermionic as well as replacement capacitors), but nothing has ever replaced TOBE dependability.

Yes, dirigibles are a thing of the past. So are worries over service call-backs, when you use dependable TOBE replacement capacitors. Install 'em. Forget 'em. Here's a typical TOBE long-life capacitor:

THE "JET" ELECTROLYTIC



- Hermetically sealed into aluminum containers with exclusive plastic sleeves.
- Compact construction; self-supported by means of rigged tinned leads.
- Capacities from 1 to 2000 mfd. Voltages from 3 to 700 vdcw.
- Temperature range to +85°C.

See your Tobe Distributor!

TOBE DEUTSCHMANN CORPORATION, INDIANAPOLIS, INDIANA

TV TUNERS REBUILT

All MAKES & MODELS

VHF
or
UHF



EXCHANGED
OR
OVERHAULED
\$9.95
NET

90 DAYS
WARRANTY

COMBINATION
UHF/VHF
UNITS
\$19.90

ALIGNED TO ORIGINAL STANDARDS

Price includes worn parts only, defective tubes and damaged major parts are extra at net prices.

Forward tuner complete with tubes, shield cover and any damaged parts.
QUOTE MAKE AND MODEL

NEW ADDRESS

F.O.B. CHICAGO OR TORONTO
will ship C.O.D.

CASTLE TV TUNER SERVICE

5710 N. WESTERN
CHICAGO 45, ILL.
U.S.A.

152 MAIN ST.
TORONTO 13
CANADA

TV Tuner

(Continued from page 29)

duce sweep output amplitude until the curve is of a usable size, and adjust the phasing until Fig. 8B is duplicated. Then, turn the blanking on to provide a base line, as in Fig. 8C.

Check marker frequency against the crystal at 210 mc. Set the marker at 211.25 mc and increase marker gain to provide a pip on the response curve (Fig. 9). This will place our marker at the video carrier frequency of channel 13. Our other check point will be 4.5 mc higher, for the channel-13 sound carrier at 215.75 mc.

At this point, let's check to see if our marker is distorting the response curve. If only a change of amplitude occurs, the marker is not distorting the curve. If a change in shape occurs, change the marker-injection point until the curve is no longer affected when the marker generator is turned on.

Another cause of distortion is standing waves on interconnecting cables. You can check for this condition by running your hand along the cables and noting any changes in the response curve. If there are shape changes, a slight increase in bias or more bonding between equipment may be necessary.

It is also possible for the local oscillator to inject too strong a signal into the grid circuit of the mixer and cause distortion. If this is suspected, simply adjust the fine tuning and watch the curve. If distortion occurs, either detune the oscillator or install a dummy oscillator tube (one with the oscillator plate pin removed).

Now that we have a stable curve, we can carry on with the alignment.

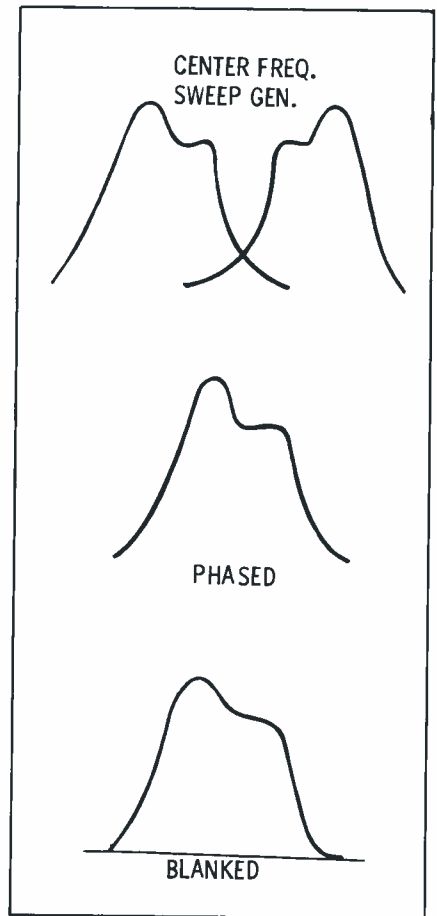

Fig. 8. Various patterns obtained when adjusting controls on sweep generator.

Most tuners provide three adjustments in the RF amplifier and mixer input circuits. One is at the input of the amplifier, the second is in the RF-amplifier output circuit, and the third is in the mixer-grid circuit. Each adjustment is tuned to a particular pole frequency, and the combination, or resultant, of the three produces the typical tuner response curve shown in Fig. 4. Normally one adjustment affects the picture-carrier end of the response curve, one affects the sound-carrier end, and the other shifts the entire curve.

Assume the picture-carrier end of



"The only thing that will draw him out, Dearie, is a Jensen needle."

SAVE TIME with

Electro-Sub



Model ES-102

ONLY **\$15.95** DEALER NET

See other SENCORE ads in this issue.

NEW!

SENCORE Electro-Sub

Check all **ELECTROLYTIC CAPACITORS** in Seconds!

Merely select the electrolytic and substitute it. 10 big electrolytics from 4 to 350 Mfd. to safely substitute in any circuit from 2 to 450 volts.

- ... COMPLETELY SAFE—no arc or spark when connecting or disconnecting.
- ... AUTOMATIC CAPACITOR DISCHARGE—within seconds after releasing test switch by unique surge protector circuit.
- ... NO CAPACITOR HEALING—surge protector circuit prevents accidental healing of capacitor being "bridged" in service work.

Available at Parts Distributors.

SERVICE INSTRUMENTS CORP. 121 Official Rd., Addison, Ill.

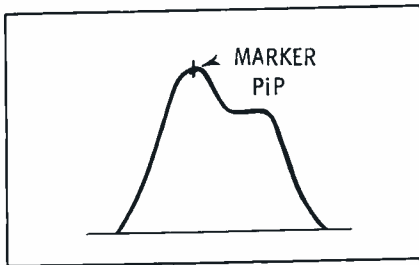

Fig. 9. A marker pip should have no effect on the shape of the response curve.

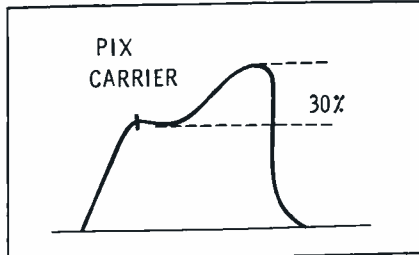

Fig. 10. Illustration of tuner response with picture carrier too low on curve.

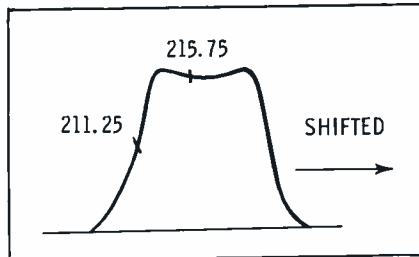

Fig. 11. This response curve has very good shape but is shifted in frequency.

the curve is down in amplitude as shown in Fig. 10. A slight rocking of each adjustment will show which one needs resetting. Some tuners will be shifted in frequency (Fig. 11), but the curve shape will be ideal. Usually, trimming of only one adjustment will shift the entire curve for proper frequency coverage. The main idea is to duplicate the ideal response curve as closely as possible while maintaining maximum amplitude. Curve shape indicates bandpass capabilities while curve height indicates gain.

If, in your particular area, you wish to favor some particular high channel, then use sweep and marker signals corresponding to that channel rather than channel 13. However, don't forget to tune the receiver to that channel.

It is not always possible to duplicate the ideal response curve, but you should be able to get it to fall within $\pm 10\%$ of the ideal. When the alignment is complete, uncouple the equipment and connect the antenna for an air check. You will be pleased with the smoother picture, since the tuner will be doing its job. ▲

CAN YOU SERVICE THIS TAPE RECORDER

Your answer is definitely *yes* if you own the comprehensive new tape recorder service manual, prepared specifically for the radio-TV serviceman by Howard W. Sams and ORRadio Industries.

And that's not all... Now, with over 2½ million tape recorders in American homes, your ability to service *every* popular make tape recorder puts you square in the middle of an exciting new 2-way profit picture. For now you will also be able to supply your customers with magnetic recording tape—in their homes, in your shop—at that moment when sales acceptance and demand are at their highest peak.

For now, provided you qualify for this special and strictly limited

2-WAY PROFIT PROPOSITION by **irish** tape,

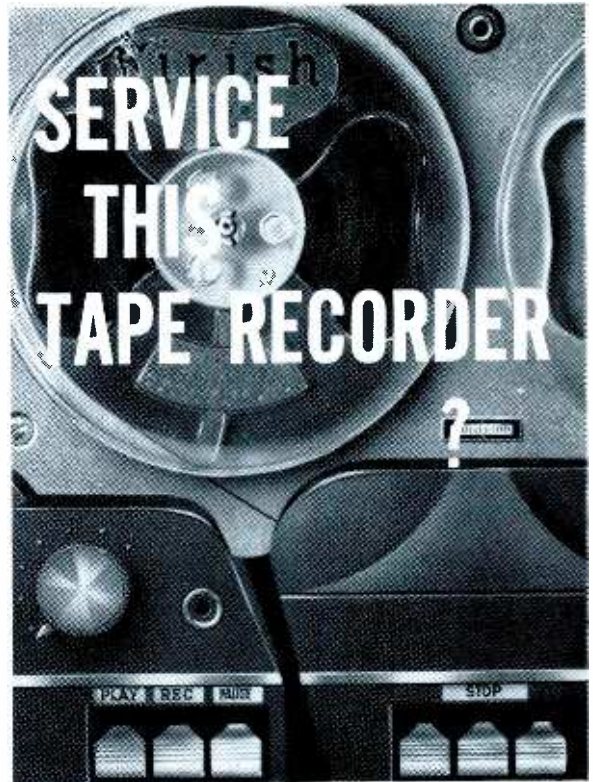

you can profitably establish yourself in your community as the expert tape recorder serviceman and franchised dealer of famous **irish** brand recording tape.

To Assure You A Handsome Profit Your **irish** Sales Service Tape Pak Will Include:

- **A COMPLETE TAPE ASSORTMENT—12 REELS—\$44.40**
Four each of the three fastest selling items in the **irish** line. You pay only our FULLY DISCOUNTED DEALER PRICE of \$44.40 for the entire twelve reels. *Your profit is \$29.60.*
- **A COMPREHENSIVE TAPE RECORDER SERVICE-MAINTENANCE MANUAL—YOURS FREE**
Prepared specifically for radio and TV service dealers by Howard W. Sams and ORRadio Industries. Complete, detailed, easy-to-follow mechanical and electronic schematics, exploded views and trouble shooting charts on every one of the most popular tape recorders. 208 pages—worth \$4.95!
- **NEWSPAPER MATS—YOURS FREE**
Mats of proven, small-space (2" x 3", 2" x 2") newspaper ads to immediately establish your NEW line of business on a sure-fire profit basis.
- **A 3-COLOR BANNER—YOURS FREE**
This banner (22" x 26") for wall or window, immediately identifies you as a franchised dealer of **irish** brand recording tape and expert tape recorder technician!
- **NATIONAL ADVERTISING**
In addition to the items in your Service Sales Tape Pak, you receive the influential support of the consistent national **irish** advertising campaign reaching tape recorder owners in every important market including: the general consumer, the hi-fi bug, the clergy, the schools, professional musicians, etc.



That's our proposition—the rest is up to you!



Dept. N-3 ORRadio Industries, Opelika, Alabama
Your 2-way profit proposition sounds interesting.

- my check for \$44.40 is enclosed
- have your representative call
- send me name of your distributor

FIRM NAME _____
ADDRESS _____
CITY _____ ZONE _____ STATE _____
YOUR NAME _____

**SUBSTITUTE PARTS
WITH-OUT SOLDERING**

Quickly *with* Easily
Has 1001 Uses!

NEW E-Z-Hook "SUB" Connectors

Connect a speaker, or

Substitute a

- transformer
- capacitor
- resistor, or
- choke

In Seconds!!

- ★ Makes connections instantly!
 - ★ Won't pull off!
 - ★ Insures positive contact!
- Saves time, money and parts in servicing, experimenting, instructing and production.

E-Z-HOOK SUB

No. 71-1...SUB.....Only 69¢ ea.

Six Colors!- for Easy Lead-Identification
Canadian Rep.: Len Finkler & Co., Toronto, Ontario

E-Z-HOOK TEST PRODUCTS
SAFE • FAST • SURE

ORDER THROUGH YOUR PARTS DISTRIBUTOR
E-Z-HOOK TEST PRODUCTS
Dept. F, 1536 Woodburn Ave
Covington, Ky

IF YOU MUST SPEND YOUR MONEY

Why not get something for it?
get **QUIETROLE**

QUIETROLE
1951 MARK REG. U.S. PAT. OFF.

Costs little more than the poorest substitutes. Why take less than the BEST...

No Product can match its merit...
None can equal its quality...
It's the answer to noisy controls and switches

QUIETROLE is the original product of its kind
MFG BY **QUIETROLE Company**
SPARTANBURG, South Carolina
IN CANADA: ACTIVE RADIO and TV DISTRIBUTORS
58 Spedina Ave., Toronto 28, Ontario

Shop Talk (Continued from page 20)

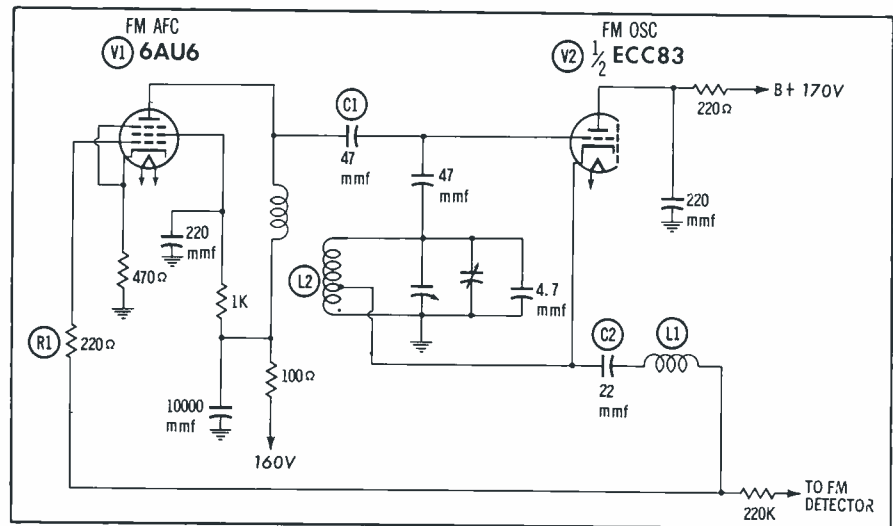

Fig. 3. AFC circuit with pentode reactance tube acts as variable inductance.

tensively employed, there have been several variations. Pilot Radio Corp., in their Model HF-42 AM-FM receiver, employ the AFC network shown in Fig. 2. Two triode sections of a 12AT7 are utilized. The first section, V1A, receives the DC output of the FM discriminator, amplifies it, and then applies it to the control grid of the second triode. This second section is connected across the tuning circuit of the FM oscillator, and in essentially all respects is similar to the AFC circuit described above. The RF voltage from the oscillator reaches the grid of V1B through grid-to-plate capacitance. R1 develops the RF voltage that drives V1B, while C1 completes the circuit by placing the far end of R1 at RF ground.

V1B presents a capacitive reactance to the oscillator, and through the variation of its plate current, varies oscillator frequency. Using a DC amplifier ahead of the AFC stage provides stronger control of the oscillator, although at greater cost. DC coupling is employed between V1A and V1B, placing a positive voltage of 15 volts on the control grid of V1B. This is offset by introducing a positive voltage into the cathode circuit of this tube.

When AFC is not desired, it is rendered ineffective by connecting a short circuit between the grid and cathode of V1B. This places a steady DC voltage between these two elements, and variations in the DC output of the discriminator do not affect V1B. In a circuit like that in Fig. 1, it is customary to simply

ground the line from the FM detector to the AFC tube. Being able to disable the AFC is an important feature, since only strong stations would otherwise be received. Weaker stations located (frequency-wise) near strong stations would never get through because the strong pull exerted by a powerful signal would keep the station locked-in for a considerable range either side of center frequency.

AFC Using Pentode

Another AFC circuit, employed by David Bogen Co., is shown in Fig. 3. A pentode is employed here, with C1 (47-mmf) connecting the plate of the AFC tube to the control grid of the FM oscillator. Here, however, we cannot assume that the RF voltage present at the plate of V1 is also brought to its control grid because the grid-to-plate interelectrode capacitance of a pentode is too small. Hence, some other means must be employed to provide the necessary grid signal. Note that C2 and L1 connect to a tap on oscillator coil L2. The oscillator signal developed at the tap is brought to the control grid of V1 by C2, L1, and R1. C2 and L1 form a series resonant circuit, and the presence of R1 makes this circuit broadly resonant. At the tube end of this network, a small interelectrode capacitance exists between control grid and cathode. Thus, the equivalent circuit appears as shown in Fig. 4, and is seen to consist of C2, L1, R1, and Cg-k.

In a series resonant circuit, the current is in phase with the applied

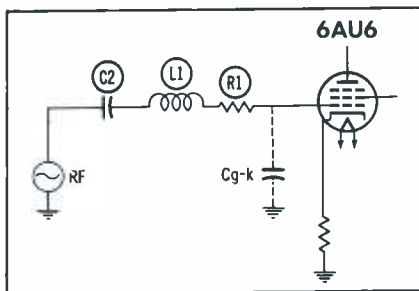

Fig. 4. Equivalent circuit of the RF coupling network to pentode AFC grid.

RF voltage (I_{RF} and E_{RF} in Fig. 5). However, the voltage that drives the AFC tube is the voltage developed across C_{g-k} and this voltage, labeled E_g in Fig. 5, is 90° behind I_{RF} . The plate current of the tube, following E_g , will also be 90° behind the RF voltage of L_2 , and V_1 thus appears as an inductance to V_2 . This is in contrast to the action in previous AFC circuits, where a capacitive reactance was developed. The control action, however, is similar.

Servicing

When an FM tuner or receiver employs AFC, there is very little difficulty in determining whether or not it is functioning. Simply tune in a station, switch in the AFC circuit, and then slowly turn the dial away from the station. The range over which the station is heard clearly, with little or no distortion, should be fairly broad, perhaps as much as a megacycle or more on either side of the assigned station frequency. As you continue to turn the dial, the AFC will suddenly release the station and its sound will no longer be heard. If another strong station is coming in on a nearby frequency, there will be a sharp switch-over from one to the other as the dial is rotated.

By way of contrast, when there is no AFC, rotating the dial past a station's assigned frequency will quickly cause the output sound to distort and background hiss to appear. The two actions are com-

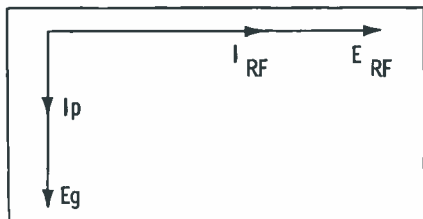

Fig. 5. Phase relationship between applied and grid signals in pentode AFC.

pletely different, and there should be no difficulty in distinguishing between them.

Trouble is indicated in the AFC circuit when hold-in is erratic, insufficient, or completely absent. The first step, of course, would be to test the tube. If it does not prove to be defective, check the DC control voltage at the grid of the AFC tube. It should vary as the dial is tuned past the station. Lack of such voltage variation indicates a defect in the path between the FM detector and the AFC tube.

We are assuming that the FM

operation is satisfactory when the AFC circuit is not in the system. This, of course, is a necessary prior condition. If the receiver does not produce the proper output with no AFC, the trouble is most likely not in the AFC network.

If the DC control voltage is reaching the AFC tube, but AFC action is impaired, check the DC operating voltages on the tube. Also check any coupling elements between the RF oscillator and the AFC tube. The circuit is fairly simple and there are very few things that can go wrong with it. ▲

Mr. SERVICEMAN

You make more profits on Stereo pickups with PICKERING'S LWD Program!

Think of it!...you can make 100% or more in profit on Stereo conversions and installation of Stereo pickups for replacement!

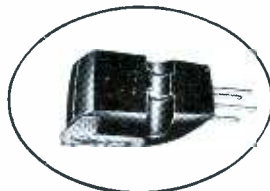

Get into the profitable stereo high fidelity business where experienced and quality conscious technicians are needed. Pickering's LWD program makes it possible for you to buy the STANTON Stereo FLUXVALVE and the STANTON Stereo KableKit from your wholesaler so you make your full markup in addition to your service charges. Call your wholesale jobber today and take full advantage of this profitable business.

EVERYTHING YOU NEED FOR STEREO CONVERSION!

STANTON STEREO KableKits

FOR CONVERTING CHANGERS



FOR CONVERTING MANUAL TONE ARMS

NEW! Low cost stereo cable assembly for converting automatic changers and manual tone arms. Prefabricated insulated and fully shielded harness assembly with all plugs and connector clips soldered... ready for instant installation! No soldering required for normal installation. Harness length 4 feet, comes complete with cable retention clips.

Model 603 Stereo KableKit for three wire systems...\$2.98

Model 604 Stereo KableKit for four wire systems...\$3.98

ASK FOR PICKERING AT YOUR JOBBER... EASIER TO SELL AND INSTALL.

FREE! Pickering Service-File, complete technical file on quality products by Pickering. Includes valuable bulletins on hum elimination, installation, maintenance, etc. Address Dept. T79 for your free Service-File.



"For those who can hear the difference" FINE QUALITY HIGH FIDELITY PRODUCTS BY PICKERING & COMPANY, INC., Plainview, N. Y.

SAVE TIME with

SENCORE

New! Improved!

TRANSISTOR CHECKER

America's newest, most popular test instrument

Simple to Operate. Controls are accurately set for each transistor by referring to replaceable set-up chart on rear. Test leads or socket provides for fast hook-up.

NOW CHECKS:

- ★ Transistors for opens, shorts, leakage and current gain. Only tester that tests power transistors as used in car radio outputs.
- ★ Crystal Diodes checks forward to reverse current ratio on all diodes.
- ★ Selenium Rectifiers checks forward and reverse currents.

Service Instruments Corp., 121 Official Rd., Addison, Ill. Available at Parts Distributors.

MODEL TRC4

\$17.95

DEALER NET

Cannot become obsolete. Approved by leading manufacturers.

See other SENCORE ads in this issue.

The **NEW** **YEATS "Shorty"**
STATION WAGON & PANEL PICK-UP
appliance dolly



YEATS Model No. 5
 Aluminum alloy
 Height 47"
 Weight 32 lbs.

Only 47" tall, this new YEATS dolly is designed for TV and appliance men who make deliveries by station wagon or panel truck. No need to detach appliance for loading into the "wagon" or pick-up . . . the YEATS "Shorty" will slide into your vehicle with ease. Has aluminum alloy frame with padded felt front, quick fastening (30 second) strap ratchet, and endless, rubber belt step glide. New YEATS folding platform attachment, at left, saves back-breaking work handling TV chassis or table models. Call your YEATS dealer today!

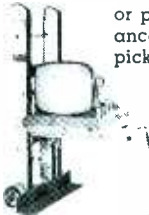

Folding platform is 13 1/2" x 24 1/2" —attaches instantly. (Platform only) \$9.95.



Furniture Pad

SEND postcard for full information on our complete line TODAY!

"Everlast" COVERS & PADS

YEATS semi-fitted covers are made of tough water repellent fabric with adjustable web straps and soft, scratchless white flannel liners. All shapes and sizes—Write.



TV Cover

YEATS appliance dolly

sales co.
 Milwaukee, Wis.

2103 N. 12th St.

P R O D U C T
r e p o r t

For further information on any of the following items, circle the associated number on the Catalog & Literature Card.

Compact Stereo Speaker System (39F)

Four types of Electro-Voice public-address speakers are available with 45-ohm voice coils to permit use in inter-com installations having 45- to 50-ohm lines. (Models 848-45 and 848LT-45 are shown in upper row of illustration; Models 847-45 and 844-45 are in lower row.) Replacement diaphragm/voice-coil kits are available in either 8- or 45-ohm impedance for the proto-types of these four speakers.



CRT Test Adapter (40F)

A new Model CR48 adapter can be plugged into the B&K Model 400 or 350 Cathode Rejuvenator Tester to permit using the instrument on special types of 110° picture tubes having 2.34-, 2.68-, and 8.4 volt heaters. Net price is \$4.95. According to the manufacturer, the CR48 does *not* supersede the Model C40 110° CRT adapter.



Audio Output Tube (41F)

The 6L6GC tube has been introduced by General Electric as a replacement for several audio types such as the 6L6GB, KT66, 5881 and 7027. Maximum plate and screen dissipation ratings are 30 and 5 watts, respectively, and maximum plate and screen voltage ratings are 500 and 450 volts. A pair of 6L6GC's in class AB1 push-pull operation can deliver 55 watts of audio output at 1.8% harmonic distortion.



Tape Speed Checker (42F)

Tape speed, like phono turntable speed, can readily be measured with a stroboscope device. The *Irish Tape Stroboscope* incorporates a disc mounted on low-friction bearings. When held against the tape (preferably on the supply reel) while the recorder is operating, the disc revolves at a speed equal to that of the tape. If speed is correct, one of the test patterns on the disc will appear stationary. The unit is priced at \$4.95.



ONLY \$100 **JUST OUT! NEW EDITION!**
HOWARD W. SAMS
"Replacement Guide for TV and Auto Radio Controls"



Lists recommended replacement controls of **CENTRALAB, CLAROSTAT, IRC, MALLORY**

Complete coverage of replacement controls for TV and Auto Radio models produced from 1947-1959 (over 22,000 TV models; 1000 auto radio models). Each recommended replacement is currently available. Exclusive "Industry Part Number" system locates recommended control replacements in just seconds. Helps you maintain inventory of most-needed controls; saves you time in selecting and ordering proper replacements. Actually pays for itself the first time you use it on a control repair job. It belongs on your bench. 8 1/2 x 11". Order now—only **\$1.00**

HOWARD W. SAMS & CO., INC.

Order from your Sams Distributor today, or mail to Howard W. Sams & Co., Inc., Dept. G-39, 2201 E. 46th St., Indianapolis 6, Ind.

Send _____ copy(ies) of "Replacement Guide for TV & Auto Radio Controls." (RGC-2). \$_____ enclosed.

Name _____
 Address _____
 City _____ Zone _____ State _____
 (outside U.S.A. priced slightly higher)

Yagi Antennas (43F)



New Winegard "K" Series yagi antennas are available in either single-channel models or broader-band versions using dual driven elements. List prices range from \$4.64 to \$13.11 for 5-element units, or \$7.89 to \$25.83 for 10-element types. The center element of the driven dipole, which is held in place by spring fasteners, can be quickly unsnapped and employed as a stacking bar.

Auto Radio Switches (44F)



Centralab is now supplying on-off switches for use with their line of exact-replacement auto-radio volume controls. Five different types replace original switches in a large number of radios built for Ford Motor Co. and Chrysler Corp. from 1942 to 1958. Types SP-1, -7 and -8 have a list price of 75¢ each, while SP-5 and -6 are \$1 apiece.

Intercom Cables (45F)



Two new Belden intercom cables, one with 9 pairs and the other with 15 pairs of AWG #22 wire, have a shield around each pair and complete isolation between all shields as protection against crosstalk. The shielding material used is *Beldfoil*, a lightweight combination of aluminum and Mylar plastic. No. 8764 and 8766 cables (with 9 and 15 pairs respectively) are available on 100', 500', and 1,000' spools.

Truck Radio (46F)



The ATR *Truck Karadio* can be attached to the cab roof of a truck, with the antenna projecting above the roof and the radio suspended below. The receiver can be tilted to aim the speaker directly at the listener. Only 7" x 4" x 6½", this radio will fit into the dash of many small foreign cars, or can be used in small boats. The unit has 6 tubes (2 of them dual-section types) and a vibrator power supply. List price is \$59.95.

Automatic Voltage Regulator (47F)



In areas where power-line voltage is intermittently lower than normal, the Perma-Power Model D-200 *Automatic Voltage Regulator* can be used to stabilize the operation of TV sets and other equipment rated at up to 300 watts. As soon as line voltage drops below 110 volts, the output of the regulator is automatically boosted by 10 volts. The boost feature becomes inoperative when line voltage returns to normal.

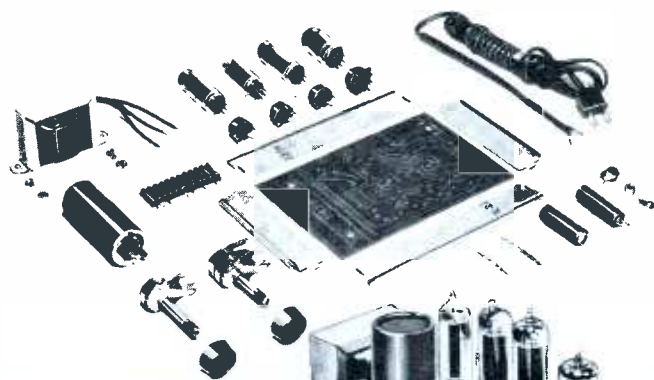

**MAKE EXTRA
PROFIT ON
STEREO CONVERSIONS**



with this

ERIE **AUDIO AMPLIFIER KIT**

Get your share of the hot market in converting monaural hi-fi sets to popular stereo. Erie "PAC" Audio Amplifier Kits give you a second profit on your assembly time. Embossed circuit board and plug-in components require little assembly time to build this high-quality four-tube push-pull audio amplifier.

See your Erie Distributor for the complete-in-one-box Erie "PAC" Kit. Also ask him to show you the new Erie *single-element* ceramic stereo cartridge with the simplest construction and the highest-fidelity characteristics.



For the name of your nearest Erie Distributor, write to:

ERIE Electronics Distributor Division
ERIE RESISTOR CORPORATION
Erie, Pennsylvania

July, 1959

American Television & Radio Co.
(ATR) 12

Arco Electronics, Inc. 59

B & K Mfg. Co. 9

Belden Mfg. Co. 13

Berns Mfg. Co. 56

Bulldog Electric Products 63

Bussmann Mfg. Co. 39

CBS Electronics 27

Castle TV Tuner Service 66

Centralab, A Div. of Globe-Union, Inc. 55

Chicago Standard Transformer Corp. 62

Clarostat Mfg. Co., Inc. 41

Cornell-Dubilier Electric Corp. 53

Delco Radio Div., General Motors Corp. 35

Doss Electronic Research, Inc. 26

E-Z-Hook Test Products 68

EICO 61

Electronic Publishing Co. 40

Erie Resistor Corp. 71

General Electric Co.—
Receiving Tube Dept. 21

Gernsback Library, Inc. 48

Jackson Electrical Instrument Co. 72

Jensen Industries, Inc. 66

Littelfuse, Inc. 4th Cover

Mallory & Co., Inc., P. R. 16-17

Merit Coil & Transformer Corp. 42

ORRadio Industries, Inc. 67

Oxford Components, Inc. 64

Perma-Power Co. 44

Pickering & Co., Inc. 69

Quietrole Co. 68

RCA Electron Tube Div. 3rd Cover, 22-23

RCA Victor Television Div. 45

Raytheon Co. 14-15

Sams & Co., Inc., Howard W. 49, 52, 64, 70

Sarkes Tarzian, Inc.—
Tuner Div. 56

Service Instruments Corp. 42, 52, 58, 64, 66, 69

Shure Brothers, Inc. 47

South River Metal Products Co. 42

Sprague Products Co. 10

Sylvania Electric Products, Inc.—
Semiconductor Div. 57

Tenna Mfg. Co. 37

Tobe Deutschmann Corp. 65

Tung-Sol Electric, Inc. 43

Vis-U-All Products Co. 40

Walsco Electronics Mfg. Co.—
Div. of Textron, Inc. 2nd Cover

Webster Electric Co. 51

Westinghouse Electric Co.—
Electron Tube Div. 18-19

Winograd Co. 24-25

Xcelite, Inc. 48

Yeats Appliance Dolly Sales Co. 70



MODEL 648		MODEL 115/715/561	
TUBE TYPE	MODEL 648	MODEL 115/715/561	MODEL 115/715/561
	FILE D.	FILE X.	FILE YZ.
18FW6	19 A2347	19 AC156	22 21MR
18FX6	19 AC1237	19 AC456	48 21MNR
18FY6	19 A237	19 AC156	18 4LR
		5 80XZ	33 5Z
		6 80X	33 4Q
32ET5	35 C123	467 52VW	33 33
36AM3	35 234	5 14W	17 51MOR
			25 25

MODEL 49		CATH. SHORTS	
TUBE TYPE	MODEL 49	D.	E.
	FILE C.		
18FW6	19 3	X 156	7 30
18FX6	19 3	X 1567	2 30
18FY6	19 3	X 17	2 32
		5X.	2 62
		267	1 62
32ET5	35 3	5	6 6
36AM3	35 3	6	5 6

Latest Chart Form 648-21, 115/715/561-11, 49-5

ANTENNAS

- 1F. **SOUTH RIVER**—Descriptive literature on snap-in type chimney and wall mounts featuring the "U" bolt for speedy, one-hand fastening of most retainers. See ad page 42.
- 2F. **TELCO**—New 8-page Catalog No. TA-60 on auto-radio antennas, suppressors, condensers, and leads.
- 3F. **TENNA**—Auto, television, and "Miracle" line antenna catalogs. See ad page 37.

AUDIO & HI-FI

- 4F. **AMERICAN MICROPHONE**—Catalog sheets on 5 new microphones plus hi-fi cables and plugs.
- 5F. **CLAROSTAT**—Form No. 751773 on sound system controls, including application data and wiring instructions for T- pads, L- pads, and attenuators. See ad page 41.
- 6F. **WEBSTER**—Descriptive bulletin on 1959 Ekotape tape recorder and components, and Teletalk intercom and sound systems. See ad page 51.

CAPACITORS

- 7F. **CORNELL-DUBILIER**—52-page booklet listing over 3300 part numbers, ratings, and sizes for twist-prong replacement capacitors used by 97 set manufacturers. See ad page 53.
- 8F. **P. R. MALLORY**—New 28-page hang-up capacitor catalog gives complete listing of all company's products. See ad pages 16-17.
- 9F. **SPRAGUE**—M-773 Difilm Mylar-Paper capacitor catalog sheet. See ad page 10.

CARTRIDGES & NEEDLES

- 10F. **ELECTRO-VOICE**—Bulletin No. 254, with the facts about the new monaural and compatible stereophonic-monaural Power Point phono cartridge.
- 11F. **JENSEN INDUSTRIES**—1960 Wall Chart containing all stereo and Dyna-Point listings. See ad page 66.

COMPONENTS (MISC.)

- 12F. **CENTRALAB**—New 20-page catalog listing over 1700 controls, ceramic capacitors, PEC packaged circuits and switches. Encompasses 128 new items, including auto-radio, stereo and twin controls, and transistor-circuit capacitors. See ad page 55.
- 13F. **ERIE RESISTOR**—Catalog D-60. See ad page 11.
- 14F. **GENERAL CEMENT**—16-page new product catalog No. 158-S on new tools and hundreds of essential service items; new 28-page Catalog No. G-61 on all types of knobs, including hi-fi, auto-radio switches and resistors.
- 15F. **IRC**—Catalog DC-8 describing 10-watt multi-range resistor kits that provide over 200 values (from 1/2 to 50K-ohms) with only 5 "MR" types.
- 16F. **OXFORD**—Catalog sheets containing miniature lamp data, information on complete line of speakers and audio-output transformers. See ad page 64.
- 17F. **RADIART**—1959 vibrator guide supplement.
- 18F. **WALSCO**—New 16-page product catalog. No. 59S, on cables, plugs, jacks, phono drives, chassis punches, TV and FM 2-set couplers, and electronic hardware. See 2nd cover.

FUSES

- 19F. **BUSSMANN**—Form TV-459 includes complete 1959 Buss fuse list. See ad page 39.
- 20F. **LITTELFUSE**—Literature on new indicating 3AG fuse post available in voltage ranges from 2.5 to 250V. See ad 4th cover.

SERVICE AIDS

- 21F. **E-Z-HOOK**—Convenient reference sheet titled, "How to Build the Five Most Useful Scope Probes," with schematics, mechanical component layouts, etc. See ad page 68.
- 22F. **PERMA-POWER**—Catalog sheet illustrating and describing new, low-cost automatic voltage regulator. See ad page 44.

23F. **SERVICE INSTRUMENTS**—Catalog sheet describing the new Model HG-104 harmonic generator, which simultaneously produces RF, IF and audio signals for quickly isolating transistor-radio troubles. See ads pages 42, 52, 58, 64, 66, 69.

24F. **YEATS**—Literature describing the Yeats appliance dolly, appliance covers, and flat padded blankets. See ad page 70.

SPECIAL EQUIPMENT

25F. **ATR**—Descriptive literature covering the Karadio, a 6-tube superhet designed for use in trucks, boats, foreign cars, and small American cars. See ad page 12.

TECHNICAL PUBLICATIONS

- 26F. **GERNSBACK**—Descriptive literature on Gernsback Library books. See ad page 48.
- 27F. **HOWARD W. SAMS**—Descriptive literature on all Howard W. Sams books covering servicing of radio, TV, hi-fi, etc. Includes data on latest books, "Audio Cyclopeda," "Marine Electronics Handbook," "Replacement Guide on TV and Auto Radio Controls," and the new and completely revised edition of the "PHOTOFACT Television Course." See ads pages 49, 52, 64, 70.

TEST EQUIPMENT

- 28F. **B & K**—Bulletin ST21-R gives helpful information on new point-to-point signal-injection technique with Model 1075 TV "Analyst;" other bulletins describe "Dyna-Quik" Models 500B, 650, and automatic 675 portable dynamic mutual conductance tube and transistor tester, plus Model 400 CRT cathode rejuvenator tester. See ad page 9.
- 29F. **DOSS**—Information on the latest in test equipment, including the Pioneer 250 Horizontal Systems Quantalyst. See ad page 26.
- 30F. **EICO**—20-page, 1959 2-color catalog describes 65 models of professional test instruments, hi-fi, and "ham" gear in both kit and factory-wired form. Shows how to save 50%. See ad page 61.
- 31F. **JACKSON**—2-color folder showing complete line of "Service Engineered" test equipment, including a dynamic tube tester with sequence switching, wide-band high-sensitivity scope, sweep-marker generator and crystal calibrator, all new VTVM with 7" meter, and wide-range capacitance checker. See ad page 72.
- 32F. **RCA**—Flyer 3F764A on RCA test equipment line. See ads pages 22-23, 45, 3rd cover.
- 33F. **VIS-U-ALL**—New line folder showing business-building test equipment for service dealers. See ad page 40.

TOOLS

- 34F. **BERNS**—Data on the 3-in-1 picture tube repair tool that serves to crimp pin and element lead to make a solid electrical connection; can also be used as screwdriver and channel selector. See ad page 56.
- 35F. **XCELITE**—Latest catalog sheet on line of serviceman-designed tools, listing various types of screwdrivers, nutdrivers, pliers, and cutters. See ad page 48.

TRANSISTORS

- 36F. **CBS**—PA-218 Tech Tips article entitled "Tubes and Transistors in Hi-Fi" by Bud Tomer. See ad page 27.
- 37F. **SYLVANIA**—2nd edition of "Transistor Characteristics and Interchangeability Guide;" also Form SD-2 describing installation hints, low-cost transistor types, and 8 easy-to-build transistor circuits. See ad page 57.

TUBES

38F. **TUNG-SOL**—30-page flip-style chart supplies electrical and physical characteristics for most important industrial, special-purpose, and military tubes. See ad page 43.



Picture of a Silverama Customer

This man needed a replacement picture tube for his TV set—and he wanted the best. So his TV technician installed an RCA Silverama—the premium picture tube made of all-new glass and all-new parts. It's the finest picture available today—just right for the customer who expects top quality and top performance.

Sell RCA Silverama with the assurance that you're delivering a completely new tube—a premium product that can command a premium price and premium profits for *you!*

★ ★ ★ ★ ★

Is your customer budget minded? Offer him an RCA Monogram—factory-rebuilt by RCA to dependable quality standards. There's no finer rebuilt made—just right for the customer whose primary consideration is price.

Sell RCA Monogram with assurance—your customers will get satisfactory performance—and you will have fewer call-backs.

Remember...

- RCA picture tubes—warranted for one full year and fit virtually every make and model TV set.
- RCA picture tubes—backed by a brand name you can sell with confidence.
- RCA picture tubes—pre-sold by an extensive and continuing national advertising campaign.

GET THE FULL DETAILS FROM YOUR AUTHORIZED RCA DISTRIBUTOR TODAY!



RADIO CORPORATION OF AMERICA

Electron Tube Division

Harrison, N. J.

dealer-serviceman's fuse rack . . .

. . . for wall mounting

LITTELFUSE

most
needed



most
wanted

...the **FUSEMASTER!**



dealer-serviceman's fuse
requirements at a glance