

SEPTEMBER 1958 35 CENTS



**RF**  
PHOTOFACT  
®

# REPORTER

**Including Electronic Servicing**

## **NEW THIS ISSUE!**

Exclusive 8-page  
editorial bonus section  
including . . .

*Video Speed Servicing  
and  
Previews of New Sets*

also in this issue

**Setting Up A Tower**  
**Guide to European Tubes**  
**Tips for Techs**  
**Record Changer Servicing**



1A 8H 635 1260E  
WM M DAVIS  
116 RIVERSIDE AVE  
CANON CITY COLO

# The "Inside Story" of Power Wire Wound Resistors

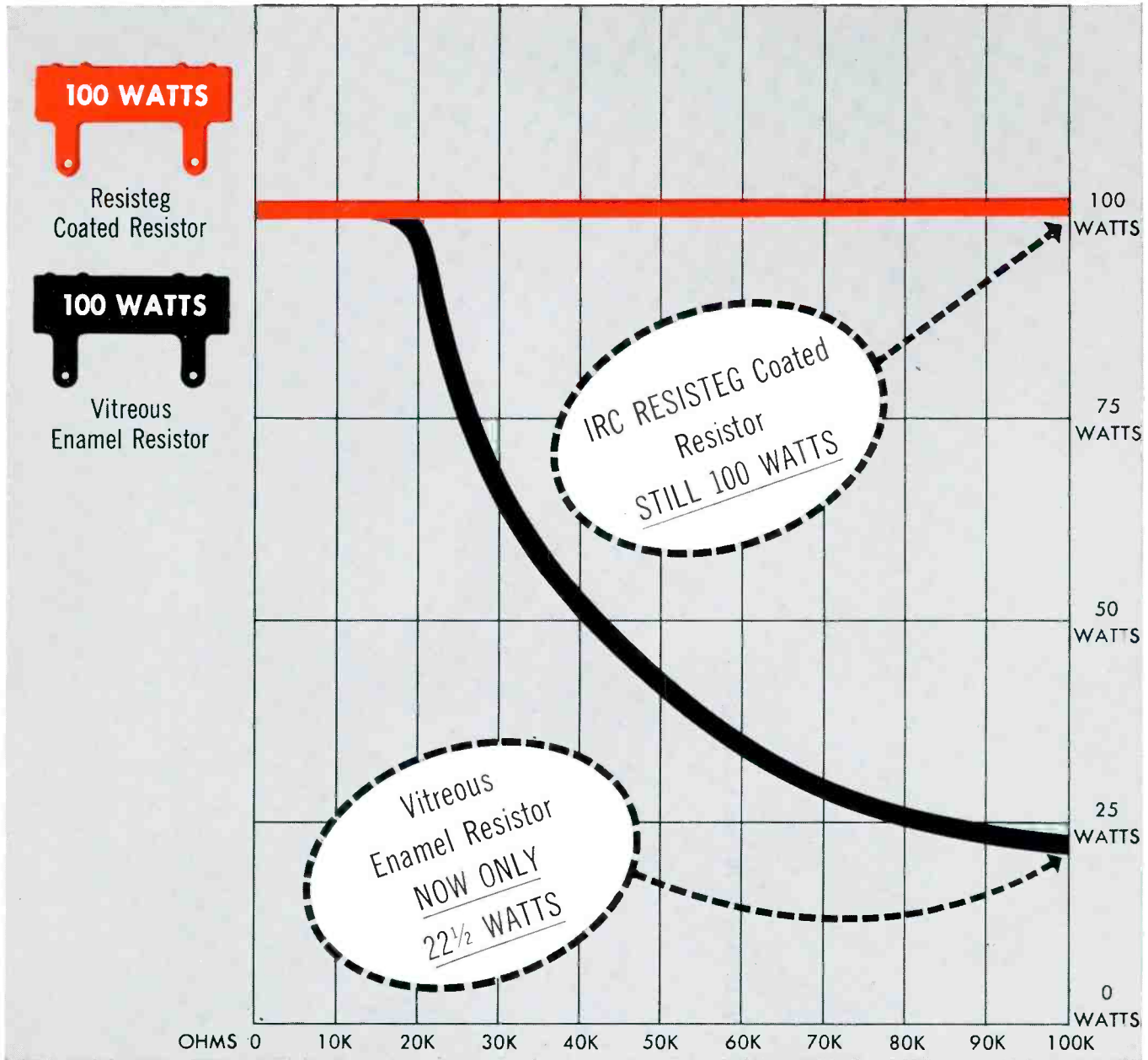

## WHY PLAY GUESSING GAMES WITH RATINGS?

**IRC Power Resistors with Resisteg Coating require no derating**

The Resisteg Coating of IRC Power Wire Wound Resistors cures at only 205°F, compared with 1200°F or more for vitreous enamel coatings. At this low curing temperature windings do not shift so that heavier wire can be used than is possible with vitreous enamel resistors. Heavier wire transfers the heat to the terminals faster, eliminates the necessity for derating at high ambient temperatures. What brings satisfaction to your customers brings business to you—IRC Resisteg Coated Power Wire Wound Resistors.

**ORDER TODAY FROM YOUR IRC DISTRIBUTOR!**



INTERNATIONAL RESISTANCE COMPANY • Dept. 368, 401 N. Broad Street, Philadelphia 8, Pa.



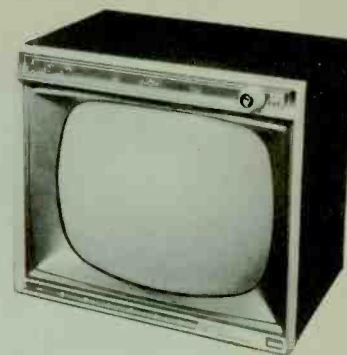
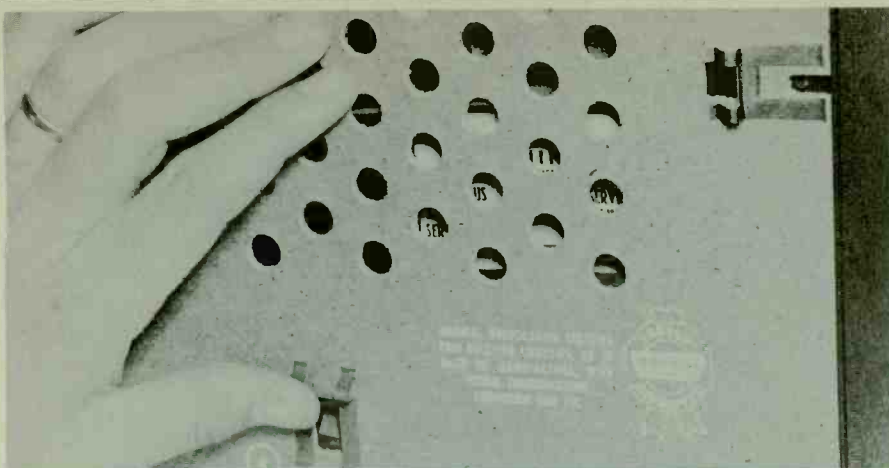

**Admiral Model T21G2  
Chassis 18A6**

This receiver highlights a new transformer-powered horizontal chassis driving a 110°, 21DEP4A picture tube. Front panel controls include channel selector, fine tuning, contrast, brightness, vertical hold, and a push-pull on-off switch as part of the volume control. The set is without a horizontal drive, width, or horizontal linearity adjustment. All tubes are of the conventional 6-volt type and a piece of #26 copper wire serves as a fuse in the filament circuit. This fuse is located under the chassis near the power transformer. If all tube heaters are out except the 5U4GB, check this wire fuse.

You'll find it very easy to remove the back from the set, for only eight slide-type clips hold it in position. The clips are released by pressing them toward the center of the receiver. Service adjustments on the rear of the chassis include a *super range* finder, vertical linearity, height, and horizontal lock.

Location of the B+ fuse, certain major components, and other auxiliary adjustments are pointed out in the over-all rear-cabinet photograph. The new Standard Coil tuner has provisions for adjusting oscillator frequency on each VHF channel. With tuning knobs removed, this adjustment is accessible through a single hole in the front of the tuner, requiring the use of 1/8" flexible non-metallic tool about 8" to 10" in length.

The AGC adjustment is entirely different from that found in previous Admiral receivers. It acts as a threshold control in a gated AGC circuit and is primarily a factory adjustment. If adjustment in the field becomes necessary, remove the tape covering and set up the control on the strongest station. Keep contrast and brightness at maximum and *super range* finder adjustment at minimum.

To remove the safety glass for cleaning, both top and bottom trim strips must be taken off. The lower strip is removed by placing the fingers as shown and pushing up on the bottom as the top is tilted outward to clear the flange on the glass retaining plate. To remove the upper trim strip, pull off all knobs and place your fingertips between the glass and bottom edge of the trim; then pull straight outward until the strip is free from the escutcheon. The three screws holding the upper retaining plate need not be removed—only loosened, but remove the four screws and bottom plate entirely. Swing the glass out at the bottom, pull down carefully and remove.

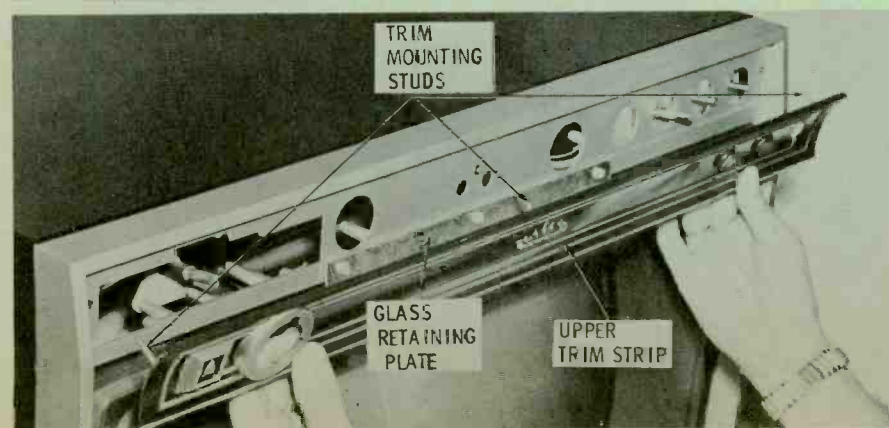
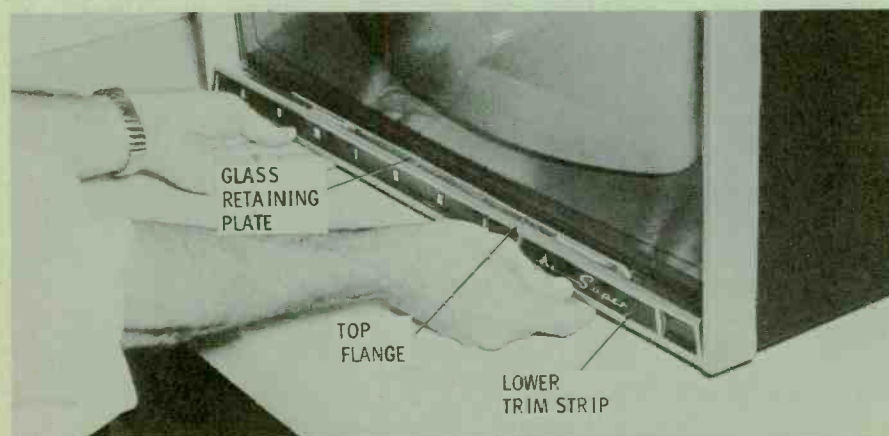
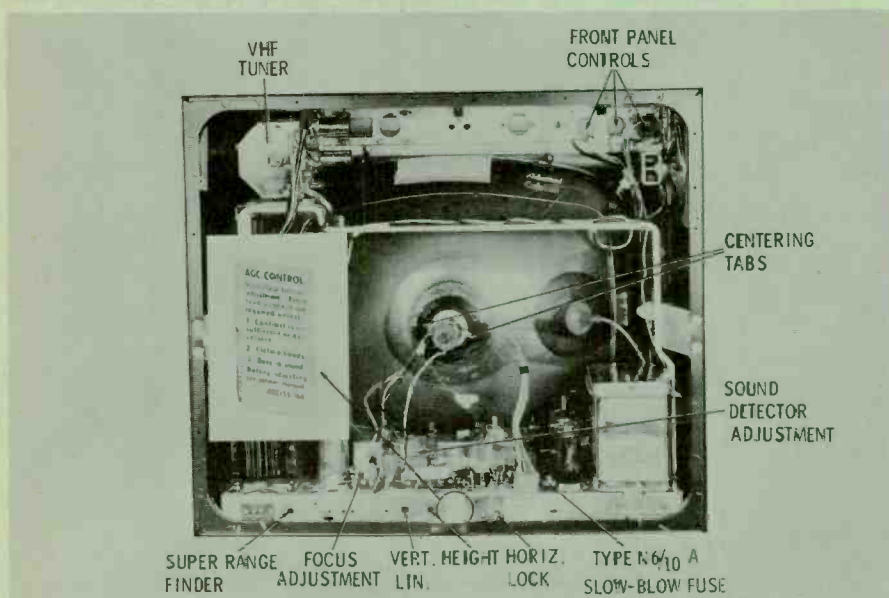

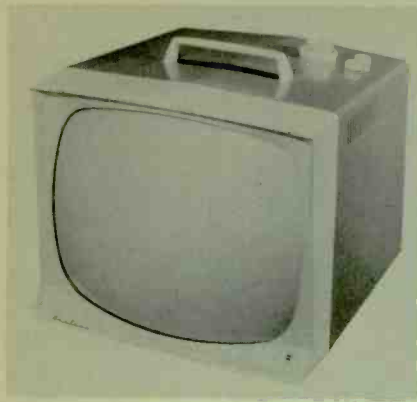

**Airline Model GTM4201A  
Chassis V2365-5**

This new 17" portable features a combination horizontal and wrap-around chassis. Cleaning of the front glass and CRT is accomplished by merely removing the entire plastic mask, which is held in place by only two screws under the front of the cabinet.

Rear chassis adjustments and the location of other features are pointed out in the photo of the cabinet back. Six bolts hold the chassis in position—four are under the cabinet and two inside on an upper bracket. The bolts are 5/16" hex-head jobs with screwdriver slots. The hot chassis employs a 600-ma tube lineup with a single plug-in silicon rectifier, the newest tube type being a 12EN6 used in the vertical output stage. This tube is, however, interchangeable with a 12W6-GT.

Note that the silicon diode is well hidden on the left side of the chassis, forward and below the more accessible fuse-type resistor. All tubes are in fairly easy reach, with a few having captive-type shields for obvious safety purposes.

No screws or clips need be removed to get into the high-voltage cage. The small compartment has a door with a spring-loaded hinge for quick substitution of the high-voltage rectifier tube. No horizontal drive, width or linearity adjustments are used, due to the close design tolerances of the flyback circuit.

When removing the chassis, the antenna terminal board must be unmounted from the back of the metal cabinet. This is accomplished by removing the two trimount snaps shown in the photograph. The control knobs grouped on top of the portable cabinet must also be removed. The channel-selector knob will come completely off, but knobs for the volume, contrast and fine tuning stay with the cabinet. A type of speed-nut is used on the plastic knob extension as a retainer. Since the name of the control is on the knob itself, this prevents any mixup when they are reinstalled.

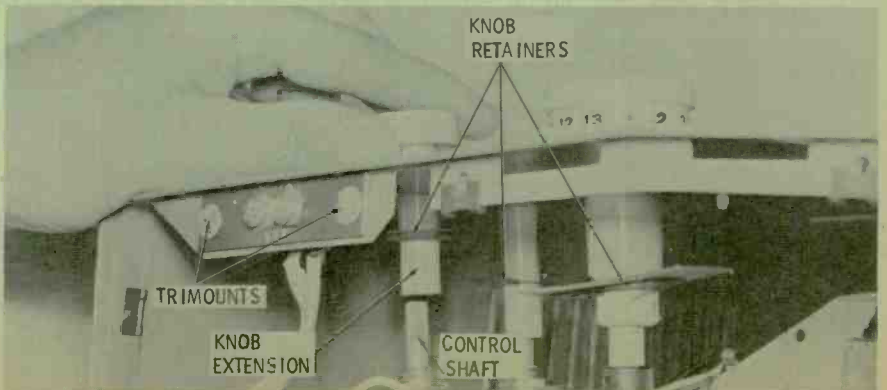
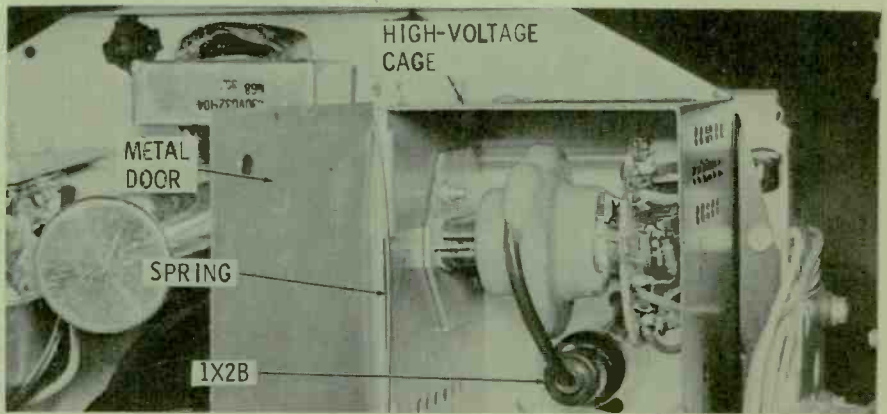
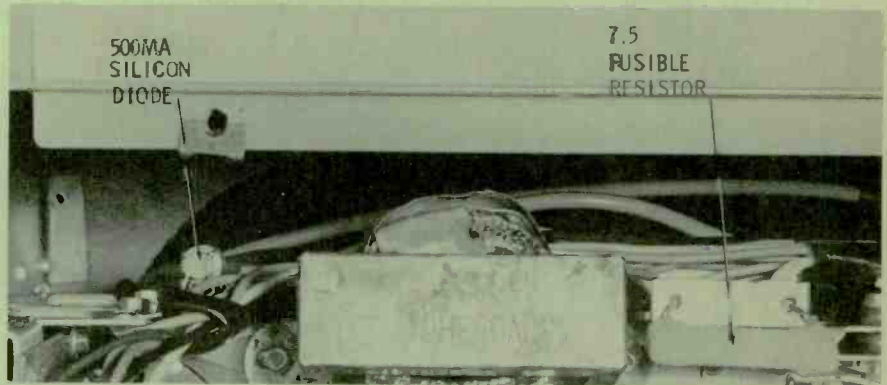
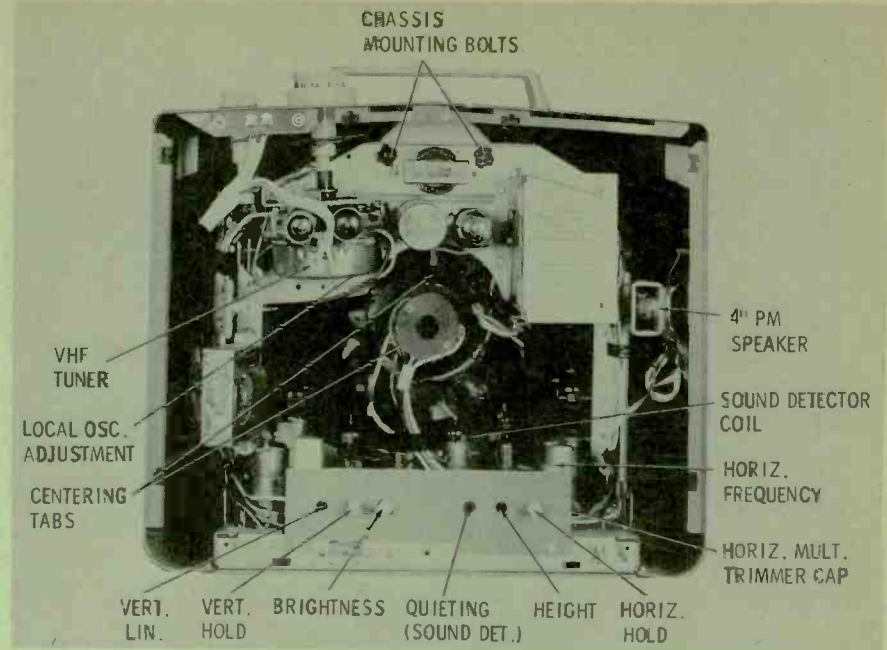



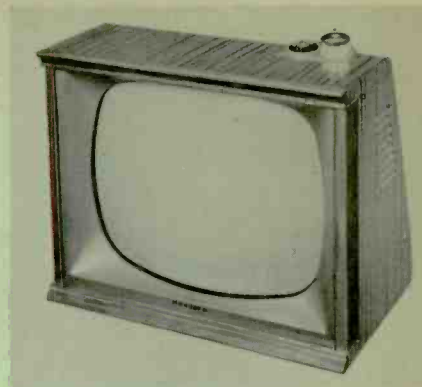
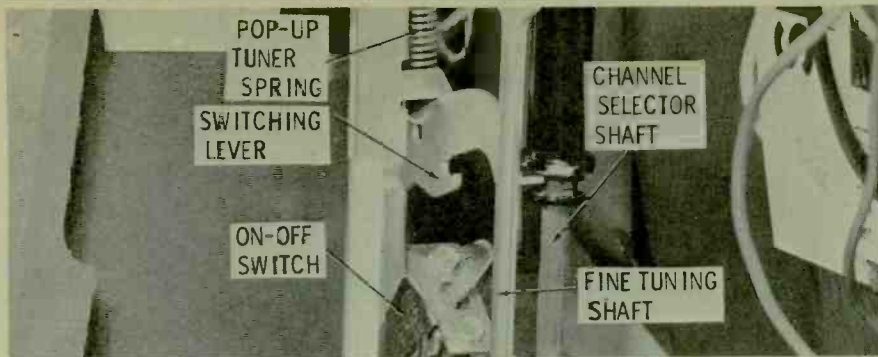

**Philco Model G4240  
Chassis 9L60**

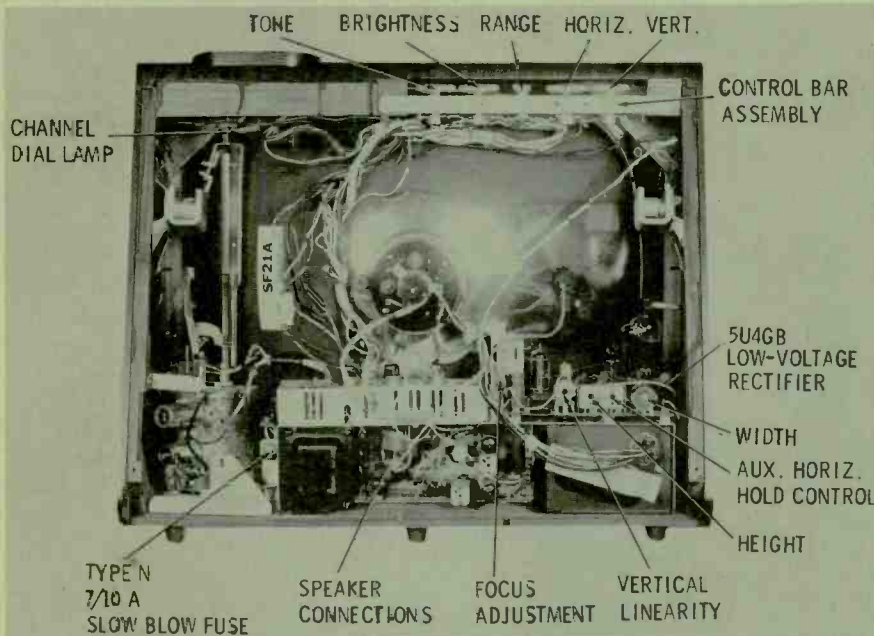

The new *Predicta* series incorporates a tri-sectional chassis consisting of a 12-position tuner with plug-in connections, the main chassis, and a separate control assembly. The transformer-powered set drives a new type 21", 110° tube with a special short-neck design. When you encounter this set for the first time, don't be embarrassed by not knowing how to turn it on. This model has a new feature called "pop-up tuning." The channel selector will pop up when the knob is pressed down slightly and then released, automatically switching on the power. When the tuner knob is pushed down again, flush with the top of the cabinet, it catches—and the receiver is automatically turned off.

Vertical linearity, height, auxiliary horizontal hold, and width adjustments are located on the rear of the chassis and are accessible through small screwdriver holes in the back cover. All tubes except the 5U4GB are easily reached with the back removed. To service this set in the home, you might check your tube caddy for a 6BY8-sound IF and AGC clamper, a 6DT5-vertical output amplifier, and a 1G3GT, which is used as a high-voltage rectifier.

The main chassis can be removed by merely taking out four 5/16" bolts from the underside of the cabinet, and unplugging yoke, speaker, tuner, and picture-tube connections. The tuner, being an entirely separate unit, can be removed by taking out two 1/4" hex-head bolts from under the cabinet and one 1/4" screw from the wooden side frame. The control assembly comes out in one section by removing the 1/4" screws at each end of the bar. To remove the separate volume-contrast assembly, take out the single 1/4" screw under the control knobs.

If you can't find the antenna connections, follow the antenna lead under the back side of the cabinet. Tilting the set forward from the rear, the terminals are located in the upper-left corner.

A special yoke has been designed for the new short-neck CRT. Included in this assembly are three adjustable magnets serving as a quadrature-centering system and horizontal-linearity control. These adjustments are only accessible with the back cover removed, and require special adjustment tools, similar in design to a slotted alignment stick. (It's not advisable to use a pair of pliers on the small tabs protruding from the magnets.) The linearity magnet, on the other hand, takes a 3/16" hex-tipped tool.

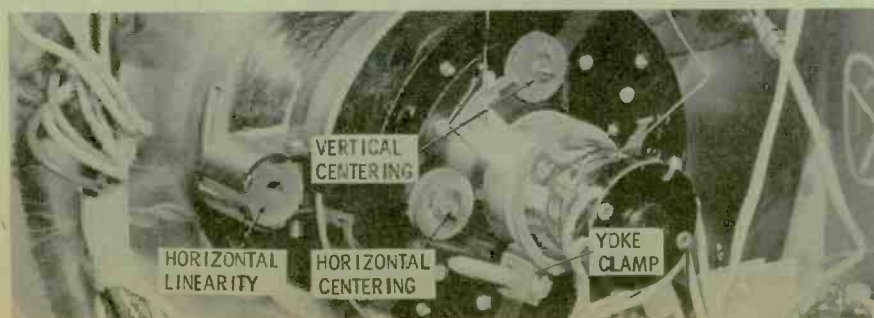
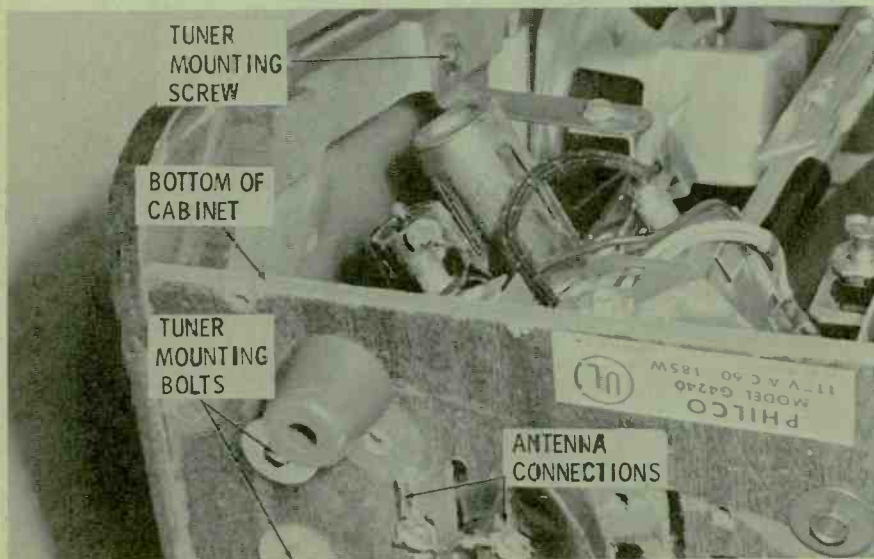



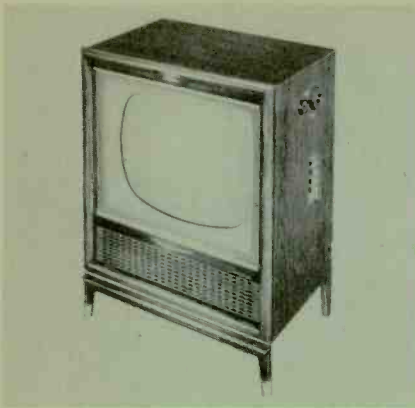

**RCA Model 21-D-9475  
Chassis KCS 121E**

This model employs a transformer-powered vertical chassis featuring almost all printed-wiring circuitry. All tubes are readily accessible and are mounted horizontally with base sections pointing forward. The 21CEP4, 110° picture tube mounts in the front of the cabinet and does not require an ion trap.

To remove the back from the set, a 5/16" hex-nut driver is required. The surge-limiter fuse pointed out in the picture is a special 3/10-amp unit which should be replaced with RCA part #945309-1 (Stock #104295) or equivalent. Although the tubes are connected in parallel, three separate filament circuits are used, and each is fused with a short length of wire located behind the power transformer. Some of the latest tube types employed in the chassis include a 6CZ5 vertical output, 6CQ8 RF converter, and 1G3GT high-voltage rectifier.

Service adjustments on the upright chassis, including vertical linearity, height, AGC, and noise-limiter controls, are positioned in the lower right section. Near the left edge of the chassis you'll find the pulse-width horizontal-frequency adjustments together with drive and width. The sine-wave adjustment is accessible through an opening in the chassis plate, and requires a hex-tipped tool. An automatic thermal cut-out, located on the side of the high-voltage cage, is connected in series with the B+ supply line, but is regulated by current through the primary of the power transformer.

The channel indicator, being apart from the tuner, is driven by a belt-pulley arrangement. When reinstalling this system and indexing the indicator with tuner channels, remember not to cross the belt into a figure eight. Tuner channel positions can be identified by noting the one long detent space during switch rotation. Rotating the selector in a clockwise direction, the longer spacing will occur when you switch from channel 13 to 2. Due to this somewhat complex indicator system, it may be much easier or quicker to remove only the chassis without tuner—if, of course, the trouble symptom indicates a fault in the main chassis.

The safety glass of this receiver can be removed by prying downward on the top channel strip as shown. After the strip clears the retainers, slide the metal retaining bar to the right and remove. Repeat this operation for the bottom channel strip and remove the glass.

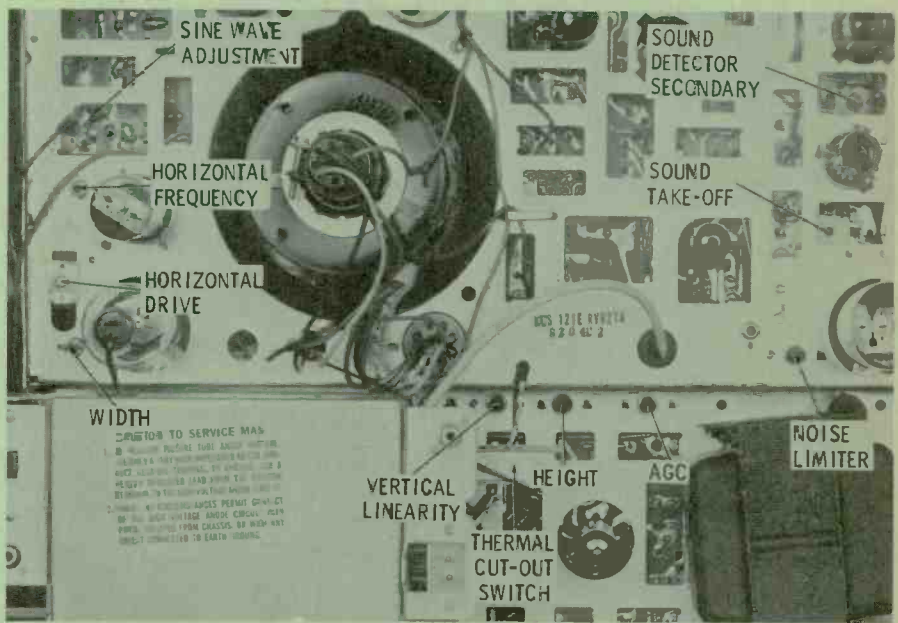
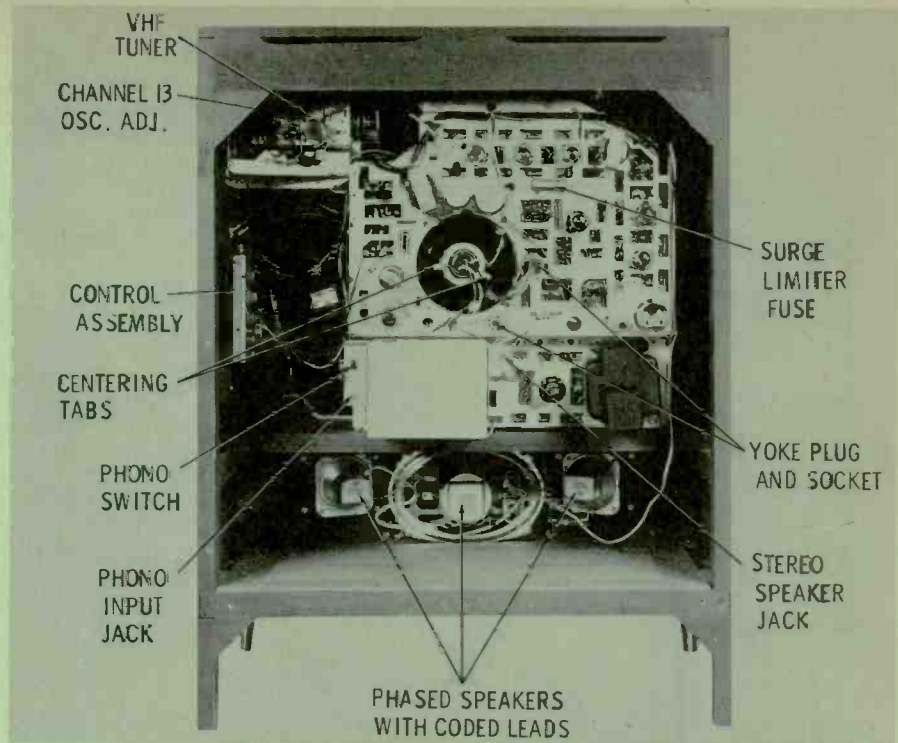



Simply by checking  
all the tubes in the TV set with **B&K DYNA-QUIK**

# YOU CAN INCREASE YOUR INCOME

## FAST AND ACCURATE

- Tests complete set in minutes
- Wins customer's confidence
- Saves costly call-backs
- Sells more tubes on-the-spot
- Avoids substitution testing
- Makes more money every day

**\$50\***  
**PER WEEK**

\*ACTUAL EXPERIENCE SHOWS  
TV SERVICEMEN AVERAGE

**2 extra tube sales  
PER CALL**

**5 calls per day in  
5 days equal \$50**

## MEASURE TRUE DYNAMIC MUTUAL CONDUCTANCE

Thousands of technicians are doing a better servicing job and are making more money today with the famous B&K DYNA-QUIK. Completely tests each tube in seconds, with laboratory accuracy, in home or shop. *Measures true dynamic mutual conductance.* Shows tube condition on "Good-Bad" scale and in micromhos. No multiple switching or roll chart. Quickly detects weak, short-life, or inoperative tubes. Shows customer the true condition and life-expectancy of tubes in the set; sells more tube replacements per call. Assures customer satisfaction and protects the service guarantee.



MODEL 675

## Model 675 AUTOMATIC Simplified, Portable, DYNA-QUIK TUBE AND TRANSISTOR TESTER

With only 60 indexed phenolic Dyna-Cards, you can test over 500 tube types. Dyna-Card automatically sets socket connections for quick, accurate tube test. Checks over 99% of the tubes most widely used in television receivers, plus popular home and portable radio tubes. Easily kept up-to-date by adding new Dyna-Cards. Tests each section of multiple tubes separately for Gm, Shorts, Grid Emission, and Life. Tests each tube for Gas Content and Grid Emission simultaneously with Short Check. Provides instantaneous Heater Continuity test. Transistor Section checks junction, point contact, and barrier transistors, germanium and silicon diodes, selenium and silicon rectifiers.

Net, **\$169<sup>95</sup>**

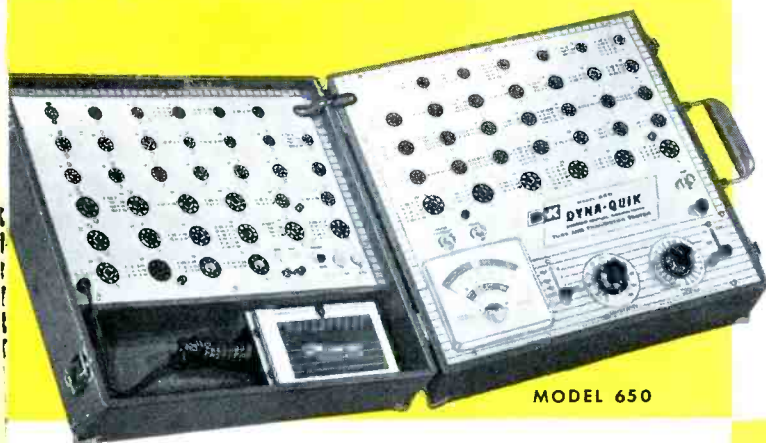

MODEL 650

## Model 650 DYNA-QUIK Fastest, Most Complete, Portable TUBE AND TRANSISTOR TESTER

Checks over 99% of the tubes most widely used in television receivers, plus popular home and portable radio tubes. Tests over 500 tube types. Lists over 125 most commonly used tube types, with settings, on socket panels for maximum operating speed. Complete listing in fast telephone-index type selector. Tests each section of multiple tubes separately for Gm, Shorts, Grid Emission, and Life. Tests each tube for Gas Content. Provides instantaneous Heater Continuity check. Includes 16 spare sockets and sufficient filament voltages for future new tube types. Transistor Section checks junction, point contact and barrier transistors, germanium and silicon diodes, selenium and silicon rectifiers.

Net, **\$169<sup>95</sup>**

Manufacturers of Tube Testers, Cathode Rejuvenator Tester,  
Television Analyst, Dyna-Scan, Transistor Tester,  
and other specialized instruments.



See your B&K Distributor or  
Send now for Bulletin AP12-R

**B & K MANUFACTURING CO.**  
3726 N. Southport Ave. • Chicago 13, Illinois

Canada: Atlas Radio Corp., 50 Wingold, Toronto 10, Ont.  
Export: Empire Exporters, 458 Broadway, New York 13, U.S.A.

**NEW  
NEW  
NEW**

Sprague **PRINT-LOK\*** 'lytics

with **universal bases**

for printed wiring boards

simplify servicing

...reduce inventory



*Another important  
Sprague "First":  
3-in-1 Universal Base  
for printed wiring  
boards*

Sprague's new PRINT-LOK Electrolytic Capacitors have a newly-developed universal base that's designed to fit all sets. A touch of your pliers is all that's needed to adapt PRINT-LOK capacitors to any one of three different types of printed circuit bases!

How's that for simplified servicing? And just as important, you need only stock a third as many 'lytics as were required previously. Still another feature—PRINT-LOK capacitors also replace standard twist-base electrolytic capacitors.

\*Trademark

PRINT-LOK capacitors are hermetically sealed in aluminum cases to give extra long life and top performance under extremely high temperatures and high surge voltages, as well as in high ripple selenium rectifier circuits.

Sprague's new TV Electrolytic Capacitor Replacement Guide K-103 gives complete listings for PRINT-LOK 'lytics as well as standard TWIST-LOK capacitors. Get your free copy from your distributor, or send 10c to cover handling to Sprague Products Co., 105 Marshall Street, North Adams, Massachusetts.

**don't be vague...insist on**

**SPRAGUE®**

*world's largest capacitor manufacturer*

**SPRAGUE RESEARCH IS CONSTANTLY PRODUCING NEW AND BETTER CAPACITORS FOR YOU**





**PF**  
PHOTOFACT  
**REPORTER**

including *Electronic Servicing*

**CONTENTS**

<b>Previews of New Sets</b>	<b>1</b>
Details on four '59 TV sets.	
<b>Video Speed Servicing</b>	<b>5</b>
Service hints on Emerson Chassis General Electric Chassis.	
<b>Letters to the Editor</b>	<b>16</b>
<b>Shop Talk</b>	<b>22</b>
Using signal-injection techniques to locate defective components.	
<b>Servicing Industrial Electronics</b>	<b>24</b>
Counter circuits that automatically time and control operations.	
<b>Hints on Record Changer Servicing</b>	<b>26</b>
Part 2: Descriptions and service hints on 4 makes.	
<b>Setting up a Tower</b>	<b>28</b>
<b>Guide to European Tubes</b>	<b>32</b>
Types used in imported equipment cross-referenced where possible with American-made equivalents.	
<b>Let's Talk Business</b>	<b>34</b>
An expert expounds on the advantages of giving estimates for shop work.	
<b>You Meet All Types</b>	<b>36</b>
<b>Servicing New Designs</b>	<b>38</b>
Examinations of the RCA KRK72E push-button tuner and the all-transistor Motorola auto radio.	
<b>Dollar &amp; Sense Servicing</b>	<b>46</b>
<b>Quicker Servicing</b>	<b>48</b>
Getting the most out of service literature.	
<b>Tips for Techs</b>	<b>54</b>
<b>The Troubleshooter</b>	<b>56</b>
<b>Notes on Test Equipment</b>	<b>60</b>
Lab reports on new troubleshooting instruments.	
<b>Product Report</b>	<b>85</b>
<b>Free Catalog &amp; Literature Service</b>	<b>88</b>
<b>Supplement to SAMS Master Index</b>	<b>89</b>

**publisher**  
Howard W. Sams

**general manager**  
Mal Parks, Jr.

**editor**  
Verne M. Ray

**associate editors**  
Leslie D. Deane  
Thomas A. Lesh  
Calvin C. Young, Jr.

**consulting editors**  
William E. Burke  
Robert B. Durham  
George B. Mann  
C. P. Oliphant  
Paul C. Smith

**art director**  
Don W. Bradley

**editorial assistant**  
Pat Moriarity

**advg. production**  
Carol B. Gadbury

**Circulation**  
Pat Tidd

**photography**  
Robert W. Reed

**advertising sales offices**

**Midwestern**

PF REPORTER  
2201 East 46th Street, Indianapolis 5, Ind.  
Clifford 1-4531

**Eastern**

Paul S. Weil and Donald C. Weil  
30-01 Main Street, Flushing 54, New York  
Independence 3-9098

**Western**

The Maurice A. Kimball Co., Inc.  
2550 Beverly Blvd., Los Angeles 57, Calif.  
Dunkirk 8-6178; and 681 Market Street,  
San Francisco 5, Calif. Exbrook 2-3365

Copyright 1958 by Howard W. Sams & Co.,  
Inc. No part of the PF REPORTER may be  
reproduced without written permission. No  
patent liability is assumed with respect  
to the use of information contained herein.



**Operating a Scope**

Is your scope collecting dust under the bench somewhere? See this picture story in next month's issue and learn how to use this invaluable test instrument.

**Hints for PC Servicing**

If printed boards are your nemesis, be sure and read how this top-notch bench man handles them.

**Check Those Electrolytics**

A stage by stage analysis of TV trouble symptoms attributed to faulty electrolytic capacitors.

**Troubleshooting the Horizontal Multivibrator**

Another article designed to help you cut down on servicing time, explaining the function of every component in this circuit, and describing the symptom which results when each becomes defective.

**ABOUT THE COVER**

The husky stalwart in the cover photo is Associate Editor Cal Young, who is just as much at home at the work bench or behind a desk as he is atop a 45-foot tower. If you're the kind of guy that likes to stand head and shoulders above the crowd or are fascinated by bird's-eye views and feel at home up in the "wild blue yonder," tower installations should be right up your alley. Those of you who think such jobs are too troublesome will be interested to learn that Cal erected this one by himself in less than two hours. Complete details are given in the three-page picture story beginning on page 28.



USE HANDY CARD AT BACK TO ENTER YOUR SUBSCRIPTION

# ***SPEED REPAIRWORK*** ***FIELD-TESTED TV SERVICE***

Time saved is money saved when repairing television sets. Because of this, General Electric has developed a whole series of original tools and devices to cut your servicing time and costs. They've been exhaustively field-tested, field-proved. They add profit hours to the work week of the television technician.

Read about these ingenious aids below! See them on your next visit to your G-E tube distributor's! Only General Electric makes available this group of special service devices—each and every one a time and trouble saver. They're easy to use . . . and easy to obtain. Ask your G-E distributor how to get them! *Distributor Sales, Electronic Components Division, General Electric Company, Owensboro, Kentucky.*



**TWIN-X WRENCH SET (ETR-752)**—designed and built expressly for TV-radio repairwork. Replaces eight hex-head socket wrenches  $\frac{3}{32}$ " to  $\frac{1}{2}$ ". Sizes are clearly marked for quick selection. Hollow shafts permit wrench to grip the nut over protruding end of bolt. Chrome-plated case-hardened steel—will stand up in long, hard service.

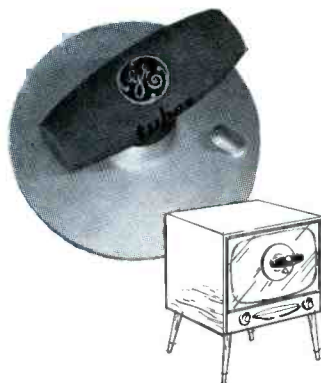

**SAFETY-GLASS PULLER (ETR-1592).** Now you can remove the television safety glass easily, without risk of cracking or chipping. Handle of this device controls a three-inch rubber suction cup with vacuum-release tip.



**NEW TUBE-FUSE-LAMP CHECKER (ETR-981A).** Only  $3\frac{1}{2}$ " by  $2\frac{3}{4}$ " by  $1\frac{1}{8}$ ". Can easily be carried in pocket. Powered by 3 "C" flashlight batteries. Will check 7- and 9-pin miniature tubes, also lock-in and octal-base types . . . picture-tube heaters . . . all TV and radio fuses . . . all filament-type pilot lamps. A "must" for technicians.

**PLUS...**

New G-E Chassis-Jack (ETR-1470)

Picture-Tube Nek-Rest (ETR-1169)

Picture-Tube Pillow (ETR-1469)

All-Type Tube Puller (ETR-1094)

Service Drop Cloth (ETR-1021)

Adjustable Bench Mirror (ETR-1275)



# WITH G-E AIDS!

## SEE THEM ON THIS PEG-BOARD COUNTER DISPLAY!

Your G-E tube distributor features this large peg-board display of TV-service aids. Inspect them in detail! All are safety-packaged in heavy transparent plastic, which keeps them clean, protects them from scratches or other injury. Be sure to look for this display at your distributor's—be sure to study the useful service aids. You'll want them all!

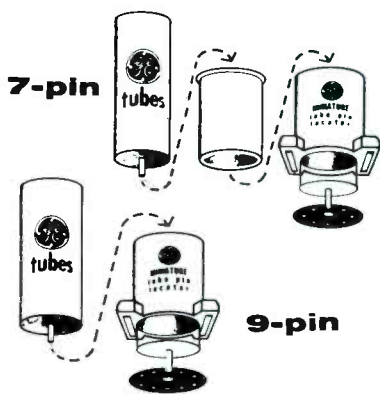

**PIN-LOCATOR FOR MINIATURE TUBES (ETR-1540).** Use it to place miniatures in hard-to-reach sockets. Centering plug positions the locator above pin holes. Magnets then hold locator while tube is turned till pins drop into socket.

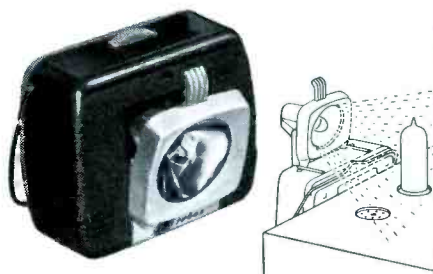

**MAGNETIC SWING-BEAM SERVICE LIGHT (ETR-1593).** Magnet holds the light securely to chassis of set, so that both your hands are free for work. Swing-beam design puts illumination just where you need it. A time-saving aid you'll want on every job. Small, fits easily in your service case. Strongly made, durable . . . uses standard flashlight bulb and batteries.



**TRI-PLEX EXTENSION LEAD (ETR-1527).** New in design. Compact for your service case, with only one lead plus adapter. Practical and easy to use. Like other G-E service aids, the Tri-Plex Extension Lead comes in a protective, reusable polyethylene container.

*Progress Is Our Most Important Product*

**GENERAL  ELECTRIC**



# Miller



\* K-TRAN IS A REGISTERED TRADEMARK



## THE FAMOUS K-TRAN<sup>\*</sup> I.F. TRANSFORMERS

A complete line of the finest I.F. transformers available anywhere at any price. Both standard and miniature sizes in all of the commonly used I.F. frequencies are stocked for immediate delivery. Conventional as well as printed circuit types are available for both vacuum tube and transistorized applications. Original equipment manufacturers will find the K-Tran the ideal choice for new equipment designs thus saving valuable engineering manhours and being assured of a top quality transformer designed by engineers with over 30 years of manufacturing experience in electronic components. The K-Tran also makes an excellent replacement transformer and will give results equal to or better than the original.

### AVAILABLE IN THE FOLLOWING FREQUENCIES

CAT. NO. Printed Circuit Types	CAT. NO. Regular Standard Types	Dimensions: 3/4" square x 2" high	FREQ.	USE
13-PH1	12-H1	262 KC	Input transformer	
13-PH2	12-H2	262 KC	Output transformer	
13-PH6	12-H6	262 KC	Output transformer with diode filter	
13-PC1	12-C1	455 KC	Input transformer	
13-PC2	12-C2	455 KC	Output transformer	
13-PC6	12-C6	455 KC	Output transformer with diode filter	
13-PC7	12-C7	455 KC	Input transformer for battery radios	
13-PC8	12-C8	455 KC	Output transformer for battery radios	
13-PC9	12-C9	455 KC	Input transformers for AC-DC radios	
13-PC10	12-C10	455 KC	Output transformer for AC-DC radios	
6203-PC	6203	4.5 MC	Input or interstage transformer	
6204-PC	6204	4.5 MC	Discriminator transformer	
6205-PC	6205	4.5 MC	Ratio detector transformer	
6206-PC		4.5 MC	Ratio Det. (GE-RTD-026)	
6207-PC		4.5 MC	Ratio Det. (GE-RTD-025)	
6208-PC		4.5 MC	Ratio Det. (GE-RTD-020)	
1463-PC	1463	10.7 MC	Input or interstage transformer	
1464-PC	1464	10.7 MC	Discriminator transformer	
1465-PC	1465	10.7 MC	Ratio detector transformer	
6230-PC	6230	44 MC	TV Converter I.F. Transformer	
6231-PC	6231	44 MC	TV First I.F. Transformer	
6232-PC	6232	42.5 MC	TV second I.F. Transformer	
6233-PC	6233	42.5 MC	TV third I.F. Transformer	
6234-PC	6234	44 MC	TV fourth I.F. Transformer	

### Available Through Your Local Distributor

Miller Quality Products are recognized by the entire electronics industry as representing the finest in workmanship, performance, and dependability.

**BUY WITH CONFIDENCE — BUY MILLER.**

\*Manufactured under K-Tran patents of and by Automatic Manufacturing Corp., Division of General Instrument Corporation.



Miniature I.F. Transformers for printed circuit transistorized applications. These miniature I.F. Transformers have tuned primary and untuned secondary windings. Proper impedance match between primary and secondary insures optimum performance.

Dimensions: 1/2" square x 3/4" high

CAT. NO.	FREQ.	SPECIFICATIONS
2031	455 KC	10K Ohm pri. to 600 Ohm Sec., Input
2032	455 KC	10K Ohm pri. to 1000 Ohm Sec., Output
2041	455 KC	25K Ohm pri. to 600 Ohm Sec., Input
2042	455 KC	25K Ohm pri. to 1000 Ohm Sec., Output
2051	455 KC	100K Ohm pri. to 1000 Ohm Sec., Input



Sub-Miniature I.F. Transformers for printed circuit transistorized applications. To our knowledge the smallest I.F. Transformers in existence. Ferrite cup core construction permits the use of extremely small shields without adversely affecting transformer operation. A high impedance, tapped primary winding coupled to a low impedance secondary provides optimum energy transfer between stages.

Dimensions: 3/8" square x 5/8" high

CAT. NO.	FREQ.	SPECIFICATIONS
9-C1	455 KC	25K Ohm pri. to 600 Ohm Sec., Input
9-C2	455 KC	25K Ohm pri. to 1000 Ohm Sec., Output



Also a sub-miniature I.F. Transformer for conventional circuitry using vacuum tubes. A 455 KC intermediate frequency transformer which has all the desirable features of the standard size I.F. and is smaller than a MINIATURE tube. Through the use of a ferrite cup core these sub-miniature I.F. Transformers offer the gain and bandwidth characteristics previously obtained only in larger I.F. assemblies. For AC-DC or battery radios.

Dimensions: 1/2" square by 1 1/2" high

CAT. NO.	FREQ.	USE
10-C1	455 KC	Input transformer
10-C2	455 KC	Output transformer

Literature on any of the above I.F. Transformers or our latest general catalog is available on request.

Over 2,000 Radio & TV parts distributors to serve you the world over.

## J. W. MILLER COMPANY

FACTORY

5917 SOUTH MAIN ST., LOS ANGELES 3, CALIF.

Phone ADams 3-4294

FAX No. XCM



*Mr. Service Dealer:  
Show Your TV-Radio Service Customer  
Where His Dollar Goes!*

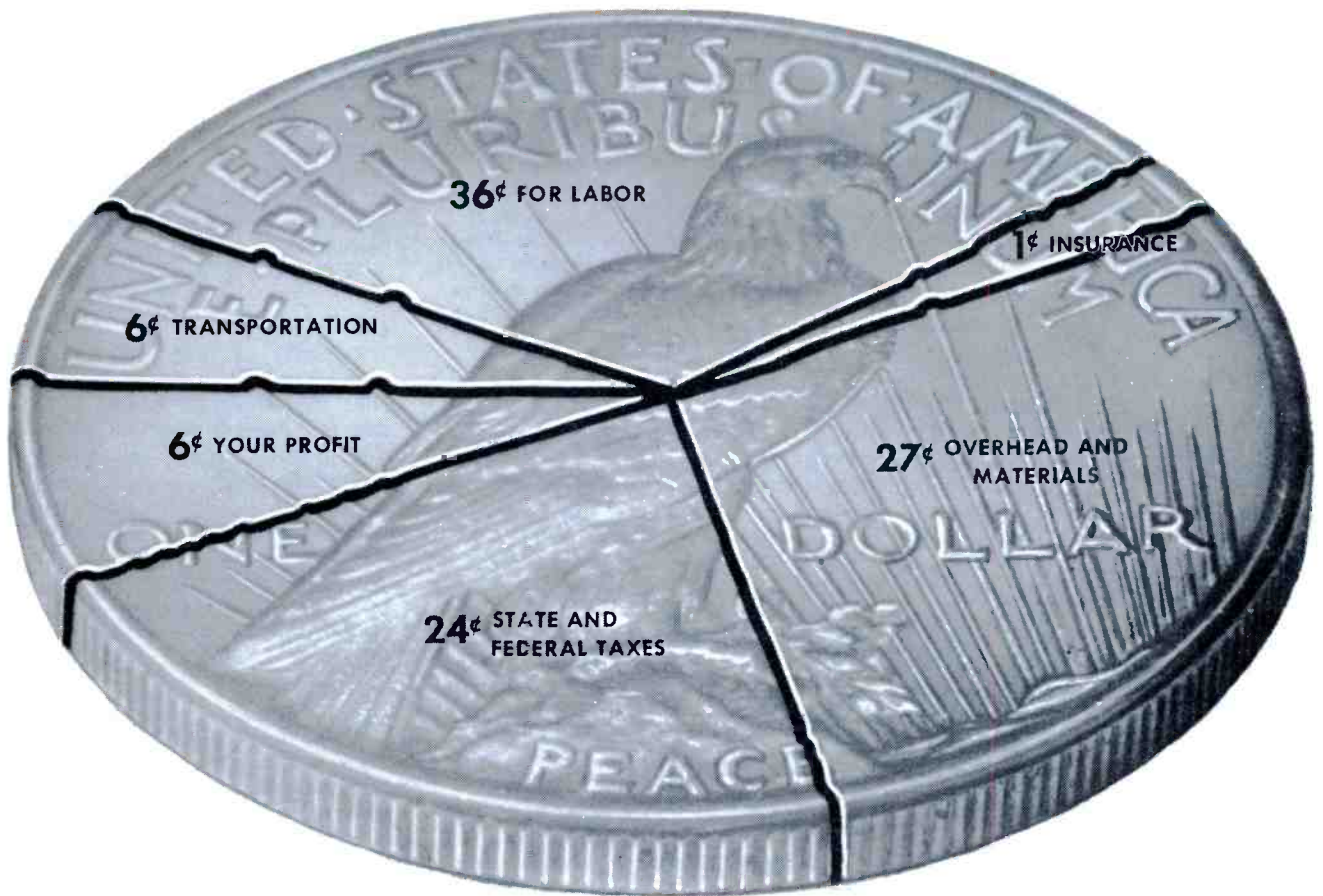

Let your customers know how much they get and how little you make on an average service call. Show them this chart. It was compiled by an independent organization for Raytheon and is based on research of Independent TV-Radio Service Dealer costs from coast to coast. It might be a good idea if you studied it carefully to see if any phase of your business is costing more than it should.

*And remember:* This 6¢ piece is your profit on a call. Don't lose it. One of the best ways to protect it is to avoid costly call-backs. And the best way to avoid call-backs is to always replace with Raytheon quality TV and Radio Tubes. Ask your Raytheon Tube Distributor to fill your orders with Raytheon Tubes.



COMING SOON! Your Chance To Climb On The GOLDEN LADDER



<b>RAYTHEON MANUFACTURING COMPANY</b>			
Distributor Products Division			
NEWTON 58, MASS. 55 Chapel Street	CHICAGO, ILL. 9501 Grand Ave. (Franklin Park)	ATLANTA 6, GA. 1202 Zonolite Rd. N.E.	LOS ANGELES 7, CALIF. 2419 So. Grand Ave.
Raytheon makes all these } Receiving and Picture Tubes, Reliable Subminiature and Miniature Tubes, Semiconductor Diodes and Transistors, Nucleonic Tubes, Microwave Tubes.			

*Operate your...*

- tape recorder
- P. A. system
- portable TV set
- hand tools

FROM YOUR CAR, Boat or Plane!

with **ATR**

# INVERTERS

FOR CHANGING YOUR STORAGE BATTERY CURRENT TO A.C. HOUSEHOLD ELECTRICITY ANYWHERE... in your own CAR, Boat or Plane!

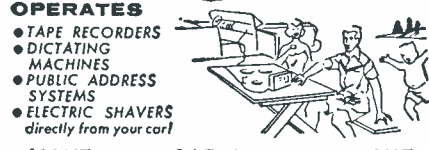
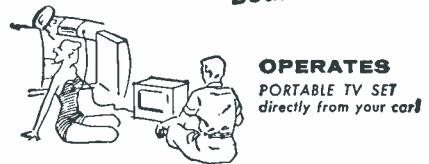

MAKE YOUR CAR, BOAT OR PLANE "A ROLLING OFFICE!"



# ATR UNIVERSAL INVERTERS

Especially designed to change 6 or 12 volt D.C. to 110 volt A.C. 60 cycles.

- for...
- EXECUTIVES
  - SALESMEN
  - OUTDOOR MEN
  - POLICEMEN
  - REPORTERS
  - FIREMEN
  - PUBLIC OFFICIALS

MODELS 6U-RHG (6 volts) 125 to 150 watts. Shipping weight 27 lbs. List price.....\$89.95

DEALER NET PRICE.....\$59.97

12U-RHG (12 volts) 150 to 175 watts. Shipping weight 27 lbs. List price.....\$89.95

DEALER NET PRICE.....\$59.97

Write for literature on other Sizes and Models of ATR INVERTERS, priced as low as \$9.95 list.

**SEE YOUR JOBBER OR WRITE FACTORY**

✓ NEW MODELS ✓ NEW DESIGNS ✓ NEW LITERATURE

• "A" Battery Eliminators • DC-AC Inverters • Auto Radio Vibrators

**ATR** AMERICAN TELEVISION & RADIO CO.  
Quality Products Since 1931  
SAINT PAUL 1, MINNESOTA, U. S. A.

# Letters to the EDITOR

Dear Editor:

About the July cover of PF REPORTER—I bet those girls are one and the same person. One side is a mirror image of the other, complete to each leaf on the plant! The bracelet jumps from the left wrist to the right, but without a wedding ring to clinch it.

BUD GIESELER  
Santa Ana, Cal.

No fair, Bud. Living so close to Hollywood, it's no wonder you caught us on this one. It's the same girl, two different poses, one negative flopped to provide the mirror effect.—Ed.

Dear Editor:

I am wondering if an error was made on page 46 of the July issue.

The decade counter unit pictured looks like it's from Berkely. All the Berkely's that I have serviced so far have 5963 tubes instead of 5964 as printed.

IRVING SEGAL  
528 N. Vista St.  
Los Angeles 36, Cal.

Okay—we admit it. It could be a 5964 except that we state it is a ruggedized version of the 12AU7. Since the 5964 is a 7-pin miniature dual-triode type with a common cathode, this couldn't very well be.—Ed.

Dear Editor:

We were very pleased with the article in your July issue showing how to install our "Genie" automatic garage door oper-

ator. However, it has caused a serious problem, as the photo in the upper left hand corner of page 14 shows the transmitter mounted incorrectly.

RAY BUHRMAN  
Alliance Mfg. Co., Inc.  
Alliance, Ohio

The trouble with the installation as shown in our article is that the transmitter is upside down. The physical position of the transmitter is fairly critical in order to permit normal operation of its mechanical modulator device. The panel on which the connectors are mounted must always be in a vertical plane. The connectors themselves do not have to be in line vertically; therefore, the transmitter can be mounted on a slanting or horizontal surface if necessary. However, the antenna plug must never be at a lower level than the other plugs.—Ed.

Dear Editor:

Referring to your July issue, which contains the article "Converting to Stereo-Disc Reproduction," please be advised that the Ronette Binofluid phono cartridge is not a ceramic unit as stated. It is Rochelle Salt.

IRA MOLAY  
Ronette Sales Corp.  
Lynbrook, N. Y.

Rochelle Salt: Sodium potassium tartrate,  $KNaC_4H_4O_6 \cdot 4H_2O$ , a colorless crystalline salt—in other words, a crystal cartridge.—Ed.

Dear Editor:

Anent the girls getting into the act, it figured! Almost from infancy, they have been parading around in our clothes and learning to carry a caddy (they call it a handbag). Have you ever taken a gander into one of these contraptions? I know for a fact that some caddies contain less!

## Letter From the Publisher

Dear Reader:

There's so much new and different about this issue of PF REPORTER, that a word of explanation is in order.

We recently purchased the magazine known as "Electronic Servicing," and have merged it into PF REPORTER effective with this edition. So here's a cordial welcome to the thousands of "Electronic Servicing" subscribers who will be receiving PF REPORTER in the future. We know you will enjoy the editorial material presented each month; it's planned with your specific interests in mind.

PF REPORTER has always enjoyed the largest circulation in its field; today, our lead over other publications is even more pronounced. For your confidence and support, we thank you.

I especially call your attention to the new 8-page bonus section on green paper bound in at the front of this issue. It introduces two new features which will appear in each and every issue . . . in addition to the regular PF REPORTER coverage we've always presented. I know you'll find the data in this exclusive section extremely valuable.

This new section, plus increased costs of production and postage, account for another change in this issue. Our single copy price has been increased to 35¢. For the next several months, our annual one-year subscription price will remain at \$3.00; on January 1, 1959, however, it will be raised to \$4.00. These necessary price increases will be more than offset by more and more of the kind of practical and useful information you've told us you want.

PF REPORTER is designed to help you, as are all our company's products. Let us hear how we can better serve your needs.

Cordially,  
Lew N. Dams



R and D Labs  
 Engineers...  
 Servicemen...  
 Hobbyists...



## NEW Belden

### WORKBENCH HOOK-UP WIRE DISPENSER KITS

Belden Dispenser Kits solve the problems of waste and inconvenience for all users of Hook-Up Wire and are available in the 14 most popular assortments of Vinyl, Vinyl-Nylon, Textile, and Teflon\* insulated wire for every requirement.

Each kit contains an assortment of Hook-Up Wire colors and types plus a portable metal dispenser rack for workbench or wall mounting. The dispenser rack provides a complete, compact, and convenient wire department for every working area at the user's finger tips, simplifies user Hook-Up Wire stock maintenance, and helps keep wire clean and orderly while keeping the workbench neat and efficient. Available at all Belden jobbers.

\* Du Pont trademark

One Wire Source for Everything Electrical and Electronic

Magnet Wire • Lead Wire • Power Supply Cords,  
 Cord Sets and Portable Cord • Aircraft Wires  
 Electrical Household Cords • Electronic Wires  
 Welding Cable • Automotive Wire and Cable



08A01 G8

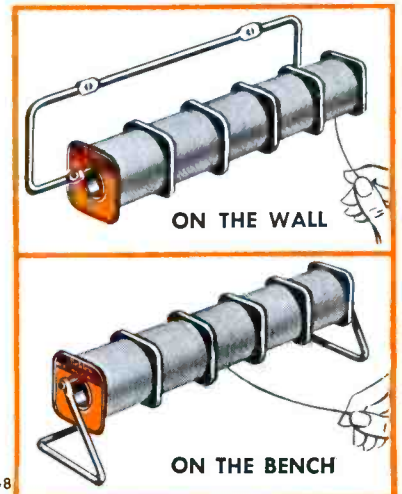

HOW ASTRON SOLVED . . . . .

# THE CASE OF "JACK THE RIPPLE"

It was a dark dreary night when the phone jangled me out of my evening cat-nap—"Watson," I cried, "pick up the line."

Within ten minutes we were off on another problem case. Our old friend "Jack the Ripple" had struck again. As Mrs. Blueberry babbled, I checked the TV set for some clues—Watson in the meantime was fumbling with the controls . . . he looked up and said, "It's Jack the Ripple's work all right, Holmes, but I don't know how he did it. I've checked everything out but I haven't found the trouble yet."

A moment of silence followed—Holmes gave a slight tug on his unlighted pipe and then exclaimed, "I have it . . . it's the capacitors." "How do you know, Holmes; you've barely looked at the set."

"Elementary, my dear Watson—they are not Astron's."

Not everyone can be fortunate enough to have a Holmes on their staff, BUT everyone can get the best in capacitors—buy and insist on Astron capacitors every time—they're "Staminized."

BLUE POINT®  
TYPE BP MOLDED PLASTIC  
TUBULARS



**ASTRON**  
CORPORATION



255 GRANT AVENUE, E. NEWARK, N. J.

What a scene it must be with "sister technician" on a service call! I can see it now. The complaint reads, "lop-sided picture, and a faint odor of burnt rubbish." Miss Servicelady sizes up the situations, digs deep into her "Pandora Box," and comes up with a nail file with which she proceeds to remove the back of the set. But success does not go to her head—she is an old hand at this sort of thing. Hasn't she removed the hinges from the door of the refrigerator with the very same tool? Another dip into the bag and presto, a hand mirror is produced. Now, with the technique born in long practice of the art of applying pressure to obstinate males, she loosens the yoke's thumb screw and straightens the picture. With a final flourish, she sprays the chassis with Arpege, by Lanvin.

I tell you, sir, this can prove to be tough competition. Not only will the girls do a bang-up job of repairs, but they'll leave the premises smelling sweet at no extra cost.

In view of these developments, I wish I had taken up sewing when I was young. That's one field the little dears want no part of today. My socks are mute evidence of that fact!

H. M. LAYDEN

New York, N. Y.

*We suspect that author Harry Layden may be using writer's license to exaggerate slightly. Maybe we're wrong, but the ladies might just add a touch of needed class to servicing.—Ed.*

Dear Editor:

It is unusual indeed for me to write to anyone in order to praise or degrade a product; however, I want to take this opportunity to tell you I think PF REPORTER is the best magazine of its kind. I also want you to know that my letter, published in "The Troubleshooter" column for May, brought me a flood of correspondence from technicians all over the country. I'm sorry I don't have time to personally acknowledge the many helpful suggestions on how to correct the trouble I was having. It is gratifying to know that there are so many in our field who are willing and able to help a fellow tradesman with a problem. Many thanks to you and the many who have written me in response to my call for help.

WILLIAM B. WOOD

Varnville, S. C.

*We think this is wonderful, Bill, and shows what can be accomplished when we all pull together.—Ed.*

Dear Editor:

Please send me a copy of your revised Tube Substitution Guide.

As long as I'm writing, I'd like to call your attention to an error in your June issue. Since when does pin 4 of a 6BQ6 tie to the control grid? It should be tied to the screen, which you have left floating—besides, you'll ruin the tube by putting B+ on the grid!

BEN'S TV SERVICE

Independence, Mo.

*Come on, you guys. Ben was the only one that caught this one.—Ed.*



# ROHN TOWERS cover 3 fields

*Bigger Profits for You!*



Rohn Manufacturing Company is the largest *exclusive* manufacturer of home television towers! Thousands of distributors, dealers and servicemen have handled, sold and installed Rohn Towers for years! They've proved to themselves that *there's more money in Rohn Towers and accessories than any other line!* Rohn Towers now *dominate the field* and profits for those handling this line are better than ever. Why? Because Rohn offers profits in all 3 major tower fields:

# 1

## HOME TV

By far the biggest usage of Rohn products has been and still is for home TV installations. In addition to finest of self-supporting towers, the Rohn line includes telescoping masts, tubing, roof towers and all other types of accessories for installations of all kinds. Wise dealers and servicemen rely *entirely* on the Rohn line for *all* installation requirements. This means **BIGGER PROFITS.**

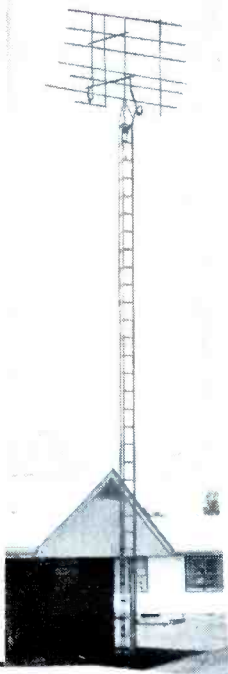

# 2

## COMMUNICATIONS

Many distributors, dealers and servicemen are making **EXTRA PROFITS** by stocking or handling the heavier type Rohn Towers that are suitable for communications purposes. There is a demand in *every area* for radio communications towers, micro-wave towers, radio telephone towers and industrial towers. You can supply this need in your area. Special new literature is available for your use.



# 3

## AMATEUR USE

Another major field of usage for Rohn Towers is in the field of amateurs and experimenters. The especially designed "fold-over" tower is the *best in the field* for the amateur because it allows working on the antenna *on the ground*. Thousands of amateurs use Rohn Towers with a tremendous demand still to be sold. You can supply this demand in your area and capture **BIG PROFITS** for yourself.



Send the coupon or write or phone today for the field that you are neglecting or those that interest you the most. ▶

**ROHN** *Manufacturing Company*

116 LIMESTONE, BELLEVUE  
PEORIA, ILLINOIS Phone 4-9156

## look at these ROHN exclusives

- **HOT DIPPED GALVANIZED**

The finest, most durable finish is available for ROHN Towers and accessories ... all done entirely on the ROHN premises under careful ROHN supervision.

- **UNEQUALLED DESIGN AND ENGINEERING**

ROHN is the only design that has stood up over the years. ROHN has been first and foremost ... and always the *leader* in new products to meet the changing demands.

- **MASS PRODUCTION FOR LOW COSTS**

ROHN was the first to utilize mass production techniques to build a superior tower at the most competitive prices. This means no sacrifice in quality yet far greater profits for you.

- **UNIVERSAL CUSTOMER ACCEPTANCE**

Thousands and thousands of installations prove the ROHN line first in customer satisfaction.

- **PIONEER MANUFACTURERS**

Pioneers in tower manufacturing—and today one of the world's largest manufacturers of this type equipment. The ROHN Company was built on satisfaction on the part of distributor, dealer and customer alike.

- **COMPLETE LINE**

Only ROHN offers a full line—*one* dependable one-stop source for all TV installation equipment. Save headaches, save shipping costs, save time ... use ROHN unequalled service *exclusively.*

**ROHN MANUFACTURING COMPANY**

116 Limestone, Bellevue  
Peoria, Illinois

GENTLEMEN: Please send me the catalog and information on the following:

TV Towers  Amateur Towers  
 Communications Towers  Full line of Rohn products

NAME \_\_\_\_\_

FIRM \_\_\_\_\_

ADDRESS \_\_\_\_\_

CITY \_\_\_\_\_ STATE \_\_\_\_\_

For superb hi-fi listening . . . **Jensen** presents . . . in modest space . . . at new low costs . . . performance challenging comparison with speakers of any size at any price!

Featuring the new Flexair\* woofer and Bass-Superflex\* enclosure principle that establish completely new standards of bass reproduction.



### NEW JENSEN CN-100 3-WAY SYSTEM



A new 12" 3-way system, the CN-100 reproducer gives a new small-scaled fine furniture look to the hi-fi speaker, ideally suited to small living spaces. The 12" Flexair superlow resonance woofer in Bass-Superflex enclosure gives full bass response to a low 20 cycles. Special 8-inch mid-channel and RP-103 h-f unit assure smooth clean response to 15,000 cycles. Crossover frequencies 600 and 4000 cycles. 32" H., 21" W., 18 1/4" D. Available in Walnut, Tawny Ash, and Mahogany. **Net Price.....149.50**

### BF-100 ENCLOSURE FOR 12" SYSTEMS

In up-to-the-minute "Flair Line" styling, the BF-100 cabinet is ideal for all 12" speakers, and system kits including those with Flexair 12" woofers. Incorporates new acoustical design with tube-loaded port for unusual extension of the l-f range. Available in Walnut, Tawny Ash and Mahogany. **Net Price.....69.50**

### JENSEN'S AMAZING TR-10 TRI-ETTE • Big Speaker Bass In Smallest Space Sophisticate's Choice In 3-Way Components

Heart of the Tri-ette is the new Flexair 12" woofer with its superlow free-air resonance of 20 cycles and high damping. In conjunction with the new Bass-Superflex enclosure, useful response down to 25 cycles is attained with the lowest distortion ever measured on such a small reproducer. Cabinet is extra rigid with Fiberglass lining. Special 8-inch midchannel handles the range from 600 to 4,000 cycles, through L-C crossover network. RP-103 Tweeter carries the response from 4,000 to 15,000 cycles. 13 7/8" H., 25" W., 11 3/8" D. Choice of Walnut, Tawny Ash and Mahogany. **Net Price .... 114.50**

ST-944 Stand . For floor use. Places top of cabinet 28" above floor. **Net Price.....12.95**  
ST-945 Base . For table or shelf. **Net Price..... 5.45**



### ABOUT JENSEN'S NEW FLEXAIR WOOFER

The new Jensen Flexair Woofers are designed to extend bass response down to very low frequencies. They have highly-damped superlow resonance at the very bottom of the audio range—16 to 20 cycles. They have an exceptional degree of linearity and are capable of a total movement of 1". In even a relatively small Bass-Superflex enclosure, they deliver their extreme low-frequency performance with a new low in distortion.



### KT-33 3-WAY SYSTEM KIT

Includes basic speaker components for 3-way system identical in performance with Jensen CN-100 and TR-10 reproducers. Includes Flexair 12-inch woofer, special 8 inch m-f unit, and RP-103 compression h-f unit. Complete with control, crossover network, wiring cable, and full instructions for building enclosure and installing speaker system. **Net Price \$80.00**



### KT-34 TRI-PLEX II SPEAKER KIT

Components used in the TP-250 Tri-Plex II reproducer. 15-inch Flexair woofer, new compression driver m-f unit, and new phase correcting supertweeter. Response from 16 cycles to upper limits of audibility in Jensen Bass-Superflex enclosure (Jensen BF-200 suggested). Complete with 400 and 4,000 cycle networks, wiring cables and instructions for building enclosure. Impedance 16 ohms. **Net Price \$179.50**

### NEW TP-250 TRI-PLEX II 3-WAY SYSTEM

This latest version of the Jensen Tri-Plex reproducer incorporates the extreme bass capability of the 15" Flexair woofer, in combination with advances in midchannel and super-tweeter design. This beautiful unit outperforms any speaker system of comparable size or cost. Excellent for superb monophonic reproduction or as one side of a stereo system. Response range, 16 cycles to beyond audibility. Components available also in kit form (see KT-34). 30 1/2" H., 34 1/2" W., 18 3/4" D. **Net Price.....294.50**

BF-200 Cabinet only for 15" Systems, net price ..... 129.75



# Jensen

MANUFACTURING COMPANY

6601 S. Laramie Ave., Chicago 38, Illinois

In Canada: J. R. Longstaffe Co., Ltd., Toronto

In Mexico: Radios Y Television, S.A., Mexico D.F.

\*Trademark

Division of The Muter Company



**DU MONT  
POSITIVE  
QUALITY**

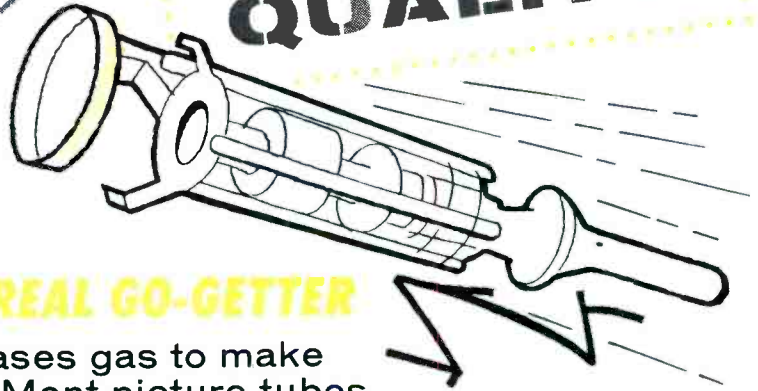

**A REAL GO-GETTER**

Chases gas to make Du Mont picture tubes sharper and to assure longer life

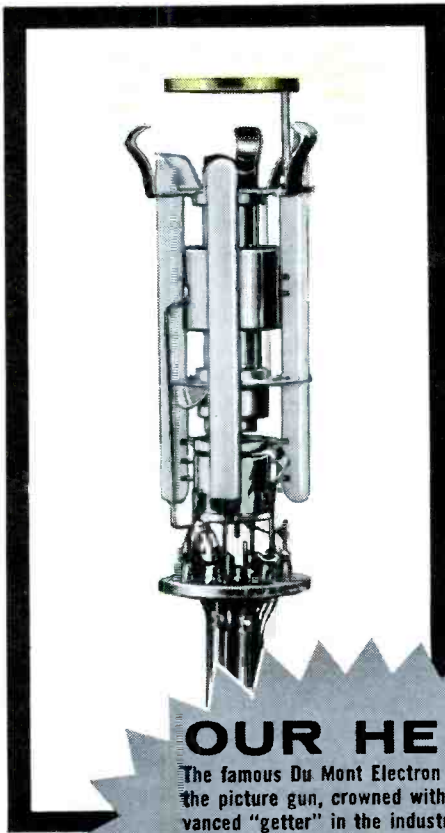

**OUR HERO!**

The famous Du Mont Electron Gun, heart of the picture gun, crowned with the most advanced "getter" in the industry. In the production of the tube, the "getter" is flashed to coat the inside of the envelope with materials that absorb gases in the tube. The Du Mont "getter" is unsurpassed for efficiency in this operation.

\*Based on Quality Control figures

**400%  
BETTER!\***

Another positive fact about Du Mont positive quality . . .

Du Mont picture tubes are 400% better when it comes to gas, and the *less gas, the better* the tube.

A gassy picture tube produces a "soft" picture, lacking the snap and sparkle customers like. Furthermore, gas in a tube greatly reduces its life.

So, for the sake of your service and profits—make that next picture tube a Du Mont!

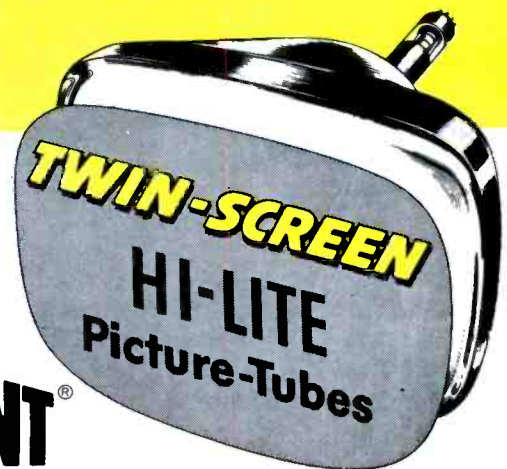

**DU MONT®**

TELEVISION TUBE DIVISION, ALLEN B. DU MONT LABORATORIES, INC., CLIFTON, N. J.

# ShopTalk

MILTON S. KIVER

Author of . . .  
*How to Understand and Use TV Test Instruments  
 and Analyzing and Tracing TV Circuits*

## Signal-Injection Testing

The practice of using signal-injection techniques for tracking down a defect has been employed for some time. Briefly, it involves injecting a signal at one point in a receiver and noting the result in another section, usually the loudspeaker or picture tube. If the signal is undistorted at the check point, then the circuits between the point of injection and the terminal device are okay. A distorted or missing signal is an indication that the trouble is situated in one of these circuits.

This method works fine with any signal that will pass through the circuit — the most common being a sine wave of AF, IF, or RF frequency. For the latter two, audio modulation is employed so that the signal will produce an effect beyond the second detector.

## Innovations of the Standard Method

In the course of working with

signal injection as a method of servicing, particularly of TV receivers, several innovations were uncovered which may not be generally known or appreciated. With them, the usefulness of this method of servicing can be broadened.

One application involves bypass capacitors, particularly those in plate- and screen-grid circuits. In the normal application of signal-injection servicing, the test signal is applied at the control grid of a stage. As an example, let us assume that a TV receiver incorporating the video circuit shown in Fig. 1 does not develop a picture on the screen, although normal sound and raster are obtained. From these symptoms, the conclusion can be drawn that the defect is located beyond the point where the sound signal leaves the video system. Using the signal-injection method, a low-frequency signal of perhaps 1,000 cycles is first injected at the control grid of

the video output tube. If the circuit is normal between this point and the picture tube, a series of horizontal bars will appear on the screen. (With a 1,000-cycle frequency, approximately 16 bars will be obtained. This is because the vertical frequency of 60 cycles will divide about 16 times into 1,000. With a modulating frequency of 400 cycles, about 6 bars will appear.)

For the next step, the signal can be injected at the control grid or plate of the video amplifier preceding the video output stage. For the sake of illustration, let's assume that nothing appears on the screen when the test signal is applied at either of these points. Automatically, we know that the trouble lies between these two stages. By moving the signal probe closer to the grid of the video output tube stage a component at a time, it is discovered that the .1-mfd interstage coupling capacitor is open.

For any component which is directly in the signal path, such as the .1 mfd capacitor, or a tube, or an entire stage, the signal injection method works extremely well and takes a minimum of time. But what about a bypass capacitor in the screen-grid or plate circuits? How can this method be utilized to determine when components of this type become defective?

Here is what can be done. As an example, we will use the third video IF stage in Fig. 2. If C14 should open, the stage may do one of two things. It may either oscillate when a signal is received, in which case a ringing effect will appear in the image, or the stage gain will drop appreciably. Sound, in general, will be weaker than normal.

To check C14, apply the signal at the screen grid. If C14 is normal, it will bypass the IF test signal to such an extent that no horizontal lines (or, at most, very weak lines) will appear on the screen. On the other hand, if C14 is open (or almost so, causing extreme loss of capacity), the full test voltage will be present at the screen grid. This will modulate tube current and cause a bar pattern to appear on the picture tube screen. (Undoubtedly, part of the test signal will reach the plate of the tube by capacitive coupling.)

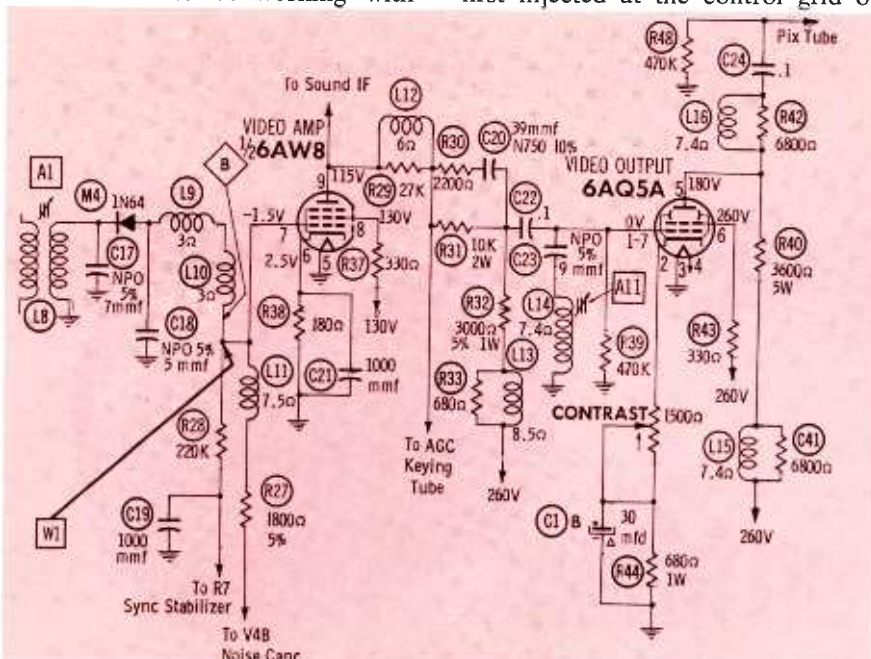

Fig. 1. Video detector and amplifier circuits in RCA Victor chassis KCS116.

• Please turn to page 70



Now! 2 Silicon  
Types for simplified  
replacement of all  
existing TV  
Rectifiers!

Hermetically  
sealed universal  
replacement  
for all silicon  
types... No heat  
sink required.

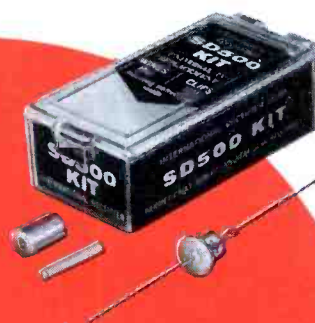

## SD-500 KIT

### IT WIRES IN!

... to directly  
replace axial  
lead type  
units.

### IT CLIPS IN!

10-second conversion  
permits plug-in into  
existing clip-type  
sockets previously  
installed. (Kit contains  
all needed parts.)

Rating: 500 ma  
@ 130 v. a.c.



International Rectifier  
*hermetically sealed*

# SILICON TV REPLACEMENT RECTIFIERS

*save installation time...  
reduce your  
rectifier stock..  
cut call-backs!*

*Hermetic sealing  
means longer life!*

Hermetic sealing provides a positive safeguard against contaminants destroying the rectifier junction. It is the most important feature to assure long, trouble-free life. Both types are manufactured to the same rigid requirements specified for military and critical industrial applications.

Available from 650 service distributors throughout the nation.

FOR SIMPLIFIED INSTALLATION AND  
MAXIMUM RELIABILITY... SPECIFY...

Hermetically sealed  
universal replacement for  
all existing selenium types...  
a direct mechanical replacement.

**NO HOLES TO DRILL;  
NO CONVERSION KIT REQUIRED**

## "UNISTAC" TV 500



Eyelet construction enables you to directly replace selenium types without time-consuming conversion efforts. Improves set performance; gives long, trouble-free life.



# International Rectifier Corp.

DISTRIBUTOR SALES DIVISION • El Segundo, California • Oregon 8-6281

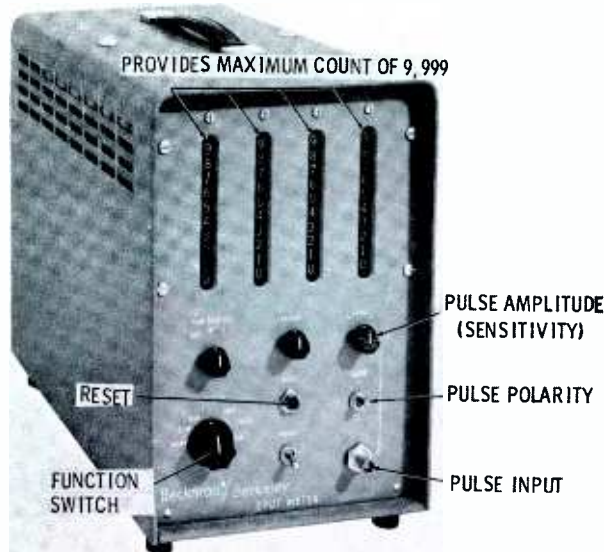

Fig. 1. Example of all-electronic counter being used to replace electro-mechanical units.

### The Latest Decades

In previous installments, we discussed Eccles-Jordan circuits and their use in binary and decade counters. It was shown how four stages can be cascaded to provide a scale factor of 16, and with pulse feedback, can be converted to provide a scale factor of 10.

Through use of these scale factors, electronic counters increase the range of mechanical counters by reducing the number of counts they must register; thus, in many newer instruments, mechanical counters have been replaced by additional electronic devices. An example of such an instrument, which is designed to operate on input pulses of either polarity, and which incorporates an input-pulse amplitude control, is shown in Fig. 1. The pulse-amplitude or sensitivity control varies the input amplifier bias, and thus prevents extraneous noise

pulses from activating the counting circuits.

Pulses are usually counted over a definite time interval. Using human efforts to watch a timer and turn the counter off is too inaccurate for most industrial applications; therefore, many commercial instruments provide an automatic stop after a definite period of time. The unit shown in Fig. 1 provides a choice of two time intervals. A one-second interval allows the four decades to directly indicate the counts per second, and a short, one-tenth of a second interval extends the maximum counts per second from 9,999 to 99,990, since the indicated number must be multiplied by ten.

In some applications, stopping the counter after it has been fed a given number of input pulses is more important than stopping it after a certain time interval. This requires the use of an additional circuit which stops the counting action when it

receives a negative pulse. The block diagram of Fig. 2 illustrates the principle behind a predetermined counting circuit. Depending upon which decade output is sampled, a negative pulse can be applied to the stop tube after ten, one hundred, one thousand, or ten thousand input pulses. This negative pulse drives V1 into cutoff and causes relay CR to de-energize, completing the circuit between the grid of the input amplifier and the negative 100-volt supply through contacts CR2. When this happens, the input amplifier is biased to cutoff and will no longer permit pulses to reach the counter circuits. Contacts CR1 prevent V1 from resuming conduction until the reset switch is activated.

### Gas-Glow Counter Tubes

Eccles-Jordan circuits aren't the only means of counting electronically. A more recent development is the glow counter tube, constructed as shown in Fig. 3, with a centrally-located plate encircled by ten separate cathodes positioned at 36° intervals. An arc is formed when a voltage greater than the ionizing voltage is applied between one cathode and the common plate. Two arc transfer grids are placed between each of the cathodes to carry the arc termination from one cathode to another. As shown, the first transfer grids (G1 elements) are nearest to the plate, while the second transfer grids (G2 elements) are positioned close to the next highest-numbered cathode.

An arc develops between zero

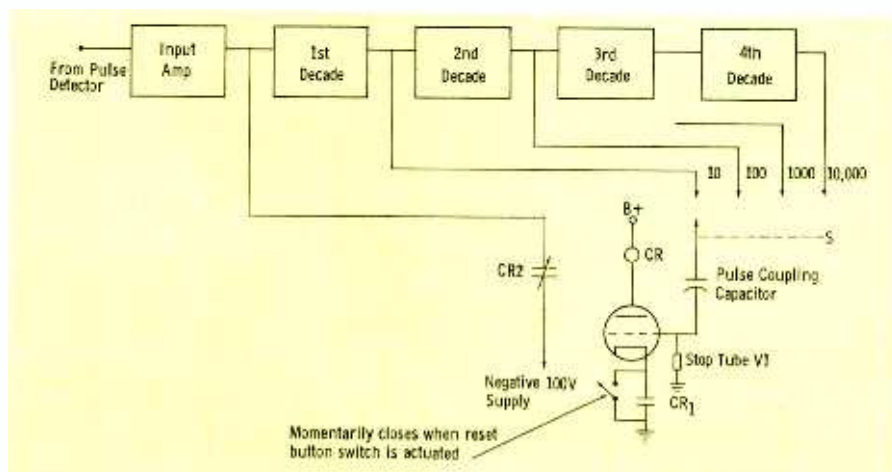

Fig. 2. Count-stop circuit blocks input after number of pulses have been applied.



cathode and plate, after reset, and progresses from cathode to cathode as input pulses are applied. On the first pulse, the first transfer grid is driven negative, creating a voltage difference between G1 and the plate greater than the arc-sustaining voltage between zero cathode and plate. The arc leaves the cathode in favor of G1. G2 is now driven negative and G1 voltage starts to decrease. The arc naturally follows the more negative voltage and therefore moves to the second transfer grid. As its voltage declines, the next clockwise cathode picks up the arc, and in this manner, the arc is forced to advance after every input pulse.

The circuit for developing the proper transfer voltages applied to the glow-tube grids can be seen in Fig. 4. The input pulse to V1 is obtained from amplifier and pulse-shaper circuits which receive the initial pulse from some form of detector. V1 amplifies the input pulse with very little distortion; thus, waveforms W1 and W2 differ only in amplitude and polarity.

Output pulse W2 is applied to coupling capacitors C1 and C2. Since C1 is one-third the value of C2, there will be a difference in the respective impedances at any given frequency. High frequencies will meet with very little impedance in the path to the G1 grids; however, the low frequencies of W2 will be essentially blocked, and the shape of the pulses reaching the G1 grids will be as shown by W3. The low frequencies of a rectangular pulse determine its width, while the high frequencies form the sharp leading and trailing edges. Thus, W3 is narrower in width than W2 but still retains the leading edge needed to drive G1 negative and cause it to

accept the arc instead of the cathode.

W2 passes through C2 and R4 on its way to the G2 grids. Most of the low frequencies pass through C2; therefore, W4 more nearly resembles W2. However, R4 attenuates the high frequencies and C3 bypasses them to ground, and the waveform loses its fast rise time, as evidenced in W4. As G1 becomes less negative, G2 becomes more negative, and the arc transfers from the former to the latter. As W4 decays, the arc seeks a more negative point and jumps to the next clockwise cathode.

External connections for the glow tube are shown, in part, by the diagram of Fig. 5. Cathodes 1 through 9 are tied together internally, leaving the zero cathode isolated so that it may serve as the starting point. Thus, two cathode connections are made — common cathodes going to a reset switch and zero cathode to ground through a load resistor. The G1 transfer grids are common, as are the G2 grids, requiring the use of only two external pin connections.

With S1 open, the arc is forced to the zero cathode. When S1 is closed, the tube is ready to accept input pulses. Transfer pulses advance the arc around the tube, and after ten input pulses it returns to the zero cathode. As this element again receives the arc, current through R6 develops a positive output pulse. Although the zero cathode continues to hold the arc, the output waveform takes the shape of W5 since C4 blocks DC and low frequency voltages.

The pulses supplied from the amplifier and shaping circuit (Fig. 4) must be fairly precise with res-

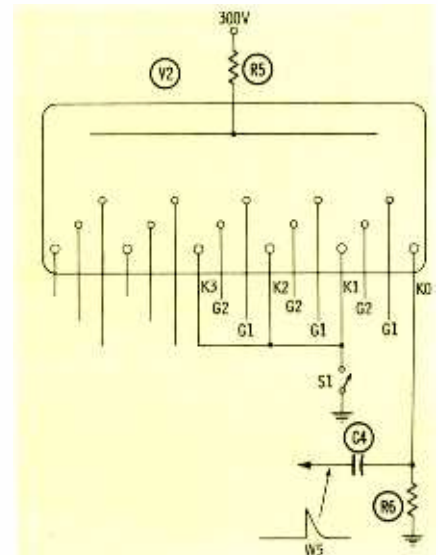

Fig. 5. Basing diagram for glow tube. Cathodes 1 through 9 tied internally.

pect to size and shape. A leaky coupling capacitor or weak tube is often the cause of missed counts. Changes in tube characteristics will cause loss of fast response and erratic counting. Generally, however, gas-glow tube circuits are easier to service than the binary stages, since one defective glow stage will cause all succeeding stages to cease operation.

### MBS Tubes

A new development in counter techniques is the Magnetron Beam Switching tube. This unit responds to pulse repetition rates up to 4 megacycles, and operates on electron path characteristics determined by magnetic and electrostatic fields. It involves the use of a permanent magnetic field, a grid placed near the electron target, and an electrostatic field formed by tube elements called spades.

Construction details are shown in

• Please turn to page 68

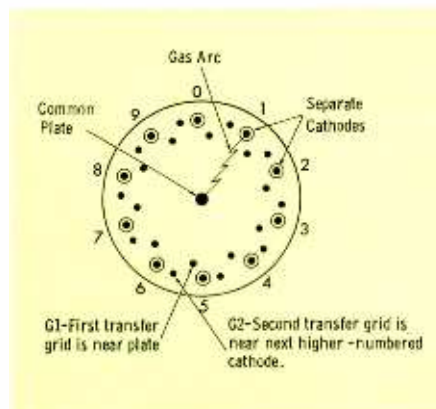

Fig. 3. Gas-glow tube has centrally-located plate and 10 separate cathodes.

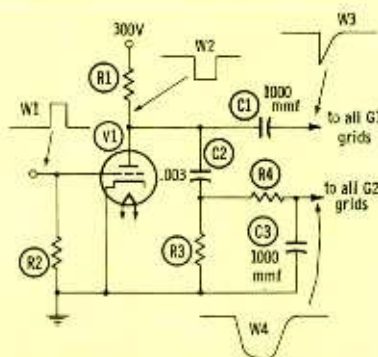

Fig. 4. Amplifier and wave-shaping circuit used to develop glow tube pulses.

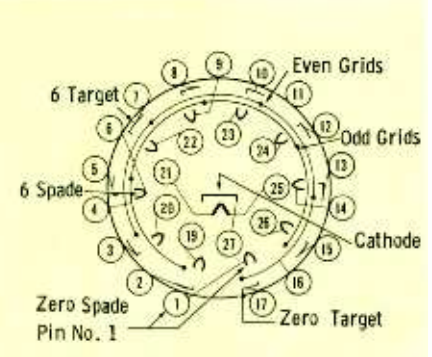

Fig. 6. Element-identification and pin-connection diagram for new MBS tubes.

# hints on Record Changer Servicing

by Calvin C. Young, Jr.

This, the final part of this series, contains valuable servicing hints on Webcor, Garrard, Monarch and Zenith changers. For hints on V-M, Collaro and Admiral units, plus general considerations that can be applied to all changers, consult the May, 1958 issue.

## Webcor Model 151

Since height, set-down, and tracking-force adjustments are the ones the serviceman will have to be concerned with most often, they will be presented first. Set-down and tracking-force adjustments for this changer (Fig. 1) are accessible when the tone arm is raised. The height adjustment (not shown) can be

reached through a hole in the top of the tone arm. To make the set-down adjustment, cycle the changer by hand until the needle starts its downward travel. Turn the set-down adjustment screw to position the needle over the center of the lead-in band at the edge of the record. Check the adjustment on various record sizes and compromise as necessary.

The height adjustment can best be made by placing a 1" stack of records (ten 12" or twelve 10" records) on the turntable, cycling the changer by hand until the needle approaches the edge of the uppermost record, and then turning the height adjustment screw until the needle just clears the stack of rec-

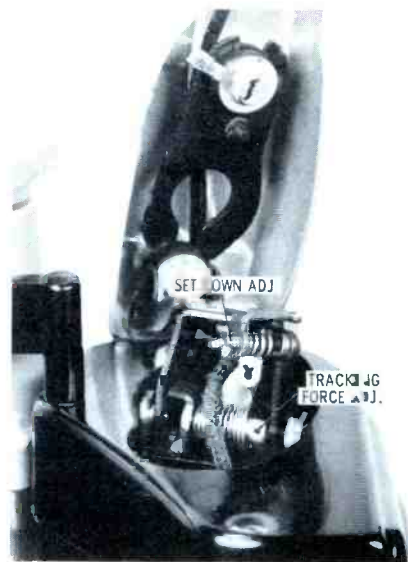

Fig. 1. Set-down and tracking-force adjustments are made with arm raised.



Fig. 2. Bristol set screw is used to raise lever bracket for height adjustment.

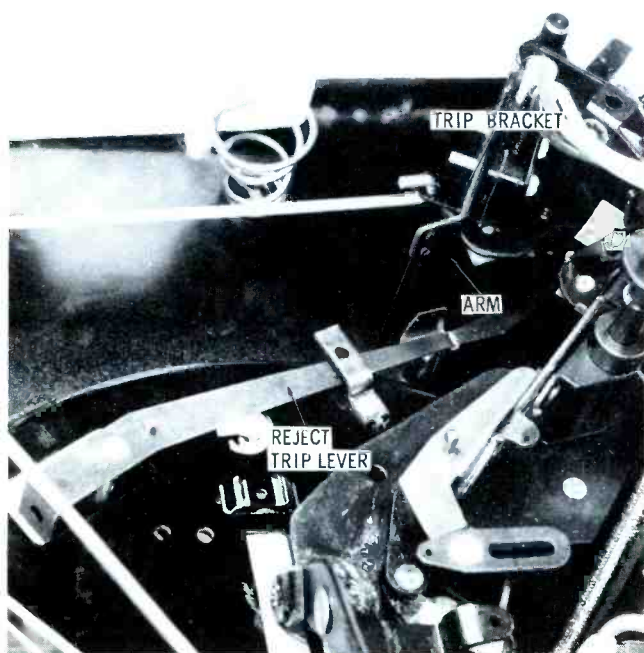

Fig. 3. Section of the Webcor Model 151 showing the velocity-tripping mechanism used. See text for adjustment procedure.

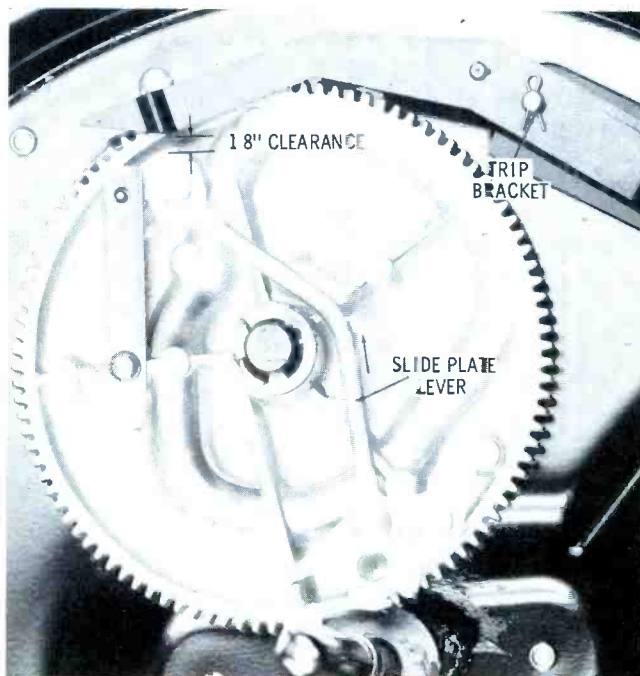

Fig. 4. Bend arm on trip bracket to obtain  $\frac{1}{8}$ " space between it and ear on slide-plate lever for proper tripping.



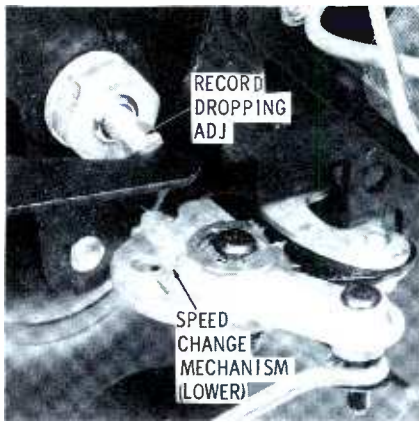

Fig. 5. Record-dropping adjustment involves changing length of dropping

ords. A further check should now be made to determine if the pickup will clear records resting on the spindle shaft. To make this check, depress the reject button and cycle the changer until the pickup rises to its uppermost level and moves outward about 1" from the edge of the turntable. Loosen the Bristol screw in the raising lever bracket (Fig. 2) and slide the collar up or down to place the needle 1-5/32" above the turntable surface.

Stylus tracking force can be adjusted to conform to specifications by reducing or increasing tone-arm spring tension. This adjustment (see Fig. 1) must be made using a small-diameter steel pin such as a metal punch. As a general rule, correct tracking pressure is achieved at 8 to 10 grams, as indicated on a suitable gram scale.

The velocity-trip mechanism in this Webcor changer features an adjustment which is made in the following manner: With the tone arm in its rest position, remove the turntable and move the slide-plate lever in the direction of the arrow (Fig. 3) as far as possible. On the under-

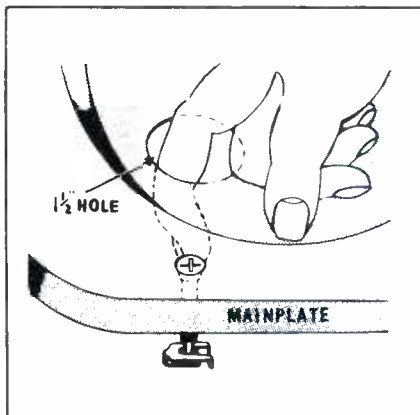

Fig. 8. Remove turntable and release locking clip to remove Webcor changers.

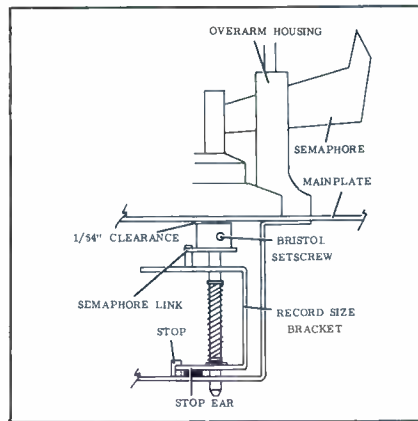

Fig. 6. Bristol set-screw is used to make semaphore adjustment on Webcor 151.

side of the changer (Fig. 4), move the trip bracket until the arm just touches the reject trip lever. In this position, there should be 1/8" clearance (Fig. 3) between the trip bracket and the ear on the slide-plate lever. Any necessary adjustment can be made by bending the arm (Fig. 4) on the trip bracket.

This changer has a record-dropping adjustment which can be used to shorten or lengthen the record-dropping arm. If a record drops on the tone arm when it is moving away from the spindle (during the change cycle) the record-dropping arm (Fig. 5) should be shortened; if it happens as it moves toward the spindle, the arm should be lengthened.

If it becomes necessary to replace the semaphore, or if the Bristol set-screw loosens, the semaphore should be adjusted as follows: (Refer to the drawing in Fig. 6.) Hold the semaphore against the overarm housing, move the record size bracket until the stop ear hits the stop, and tighten the Bristol screw, leaving 1/64" clearance as indicated.



Fig. 9. Zenith crest points toward front for correct 45-rpm spindle installation.

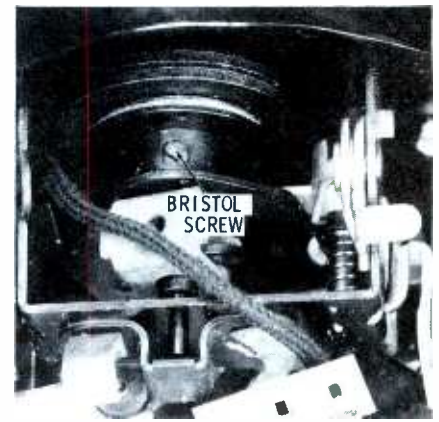

Fig. 7. Bristol screw engages pickup-raising shaft to reinstall pickup arm.

Should it become necessary to remove the tone arm, it can be quickly reinstalled because the Bristol set-screw (Fig. 7) engages a small indentation in the tone-arm shaft. Make sure the pickup lead does not restrict movement of the tone arm and that the arm moves freely over its appointed course during the change cycle.

To remove the changer from Webcor record players of the table model hi-fi variety, remove the turntable and release the locking clip as shown in Fig. 8. The front end of the changer may then be lifted about 3 1/2" and pulled forward to free the rear-mounting stud. After disconnecting the power and signal cables, the changer can be easily removed.

#### Zenith Model S-14086

The 45-rpm spindle which adapts this changer for the large-hole 45-rpm records is easily installed if the Zenith crest is pointed toward the front of the changer as shown in Fig. 9. The adapter should be gently pushed straight down over the spindle. Forcing the adapter will cause

• Please turn to page 78



Fig. 10. Height and set-down adjustments are made with Phillips driver.

# Setting up a TOWER

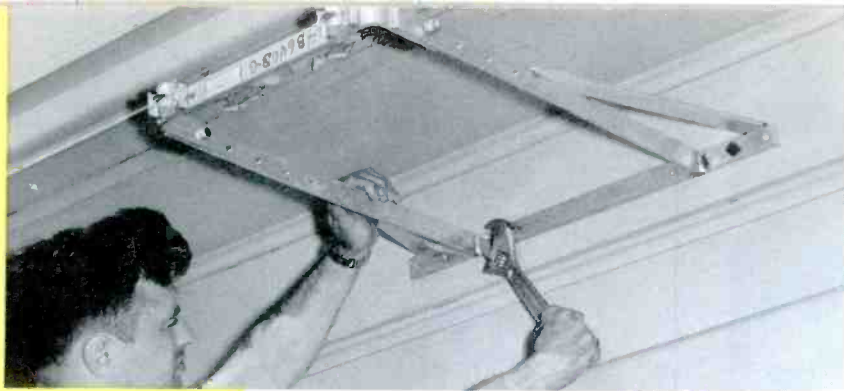

Mounting the House Bracket

Even though this is classed as a self-supporting tower, a house bracket is used in conjunction with the base mount to provide a stronger installation. The bracket is positioned with the use of a carpenter's level to make sure it is perfectly level. We used the level to scribe a line on the wall and located the pilot holes for the lag screws along this level line. The lag screws should be of the size specified and must fasten into the studs and not just into the siding. The bracket should be as high as possible, since this will determine the maximum height of the tower without guying.



The Base Next

Drop a plumb line from the house bracket to line up one side of the tower. It is of utmost importance that base and bracket be in exact alignment and that the base be perfectly level; otherwise, the tower will be tilted. In this installation, we are using a drive base that consists of a reinforced metal plate and three stakes, each 4' long. Notice that a drive tool (supplied as an accessory) is being used to prevent damage to the base. The first section of the tower fits over the three stakes and bolts in place. The holes in the mounting stakes can be aligned by inserting a large Phillips screwdriver through a hole in each stake and twisting as required. Bolt the first section of the tower to the base and secure the house bracket before attempting to add subsequent sections.

## Tower Bolts

The bolts and nuts used to join the sections of this tower were shipped in one leg of each section. Each section of tower must have the metal plug removed before installing that section. A small-shank screwdriver is a must here. With other towers, the bolts may be shipped in cloth bags or secured in place in the tower legs, but in any case be sure you have the bolts before starting the job. Tower bolts are specially-hardened and should not be replaced with common hardware varieties.

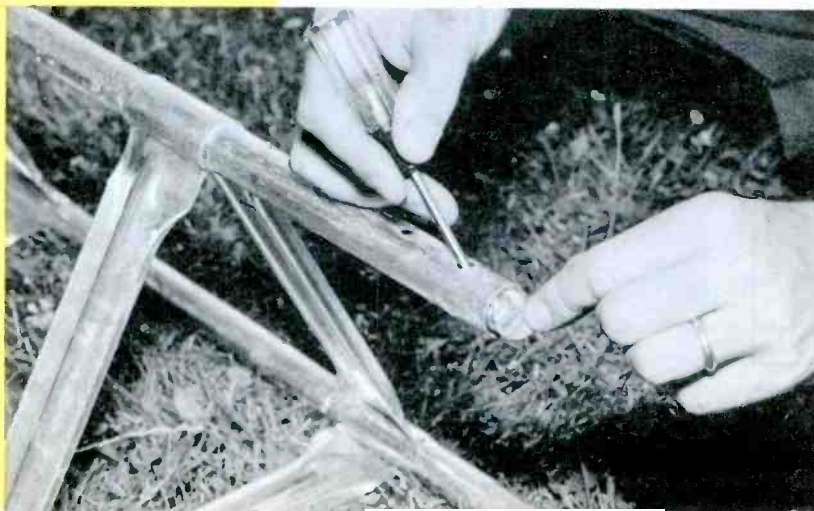

*Installing self-supporting steel towers for TV receiving antenna systems is a relatively easy job—if you know how. The little tricks and bits of know how that make tower installation easy are illustrated in this pictorial coverage. The only special tools required for this installation were a 3-lb. sledge, plumb bob, and carpenter's level. The erection fixture can be obtained from the distributor from whom you purchase the tower, and reused on subsequent installations. The approximate erection time for a 35' to 50' tower such as the one pictured is about 2 to 3 hours for two men. Where we have shown the top section being hoisted into place without an antenna, the antenna of your choice complete with lead-in attached would be mounted prior to erection. The rotor wire can be attached later, as can suitable stand-off insulators.*



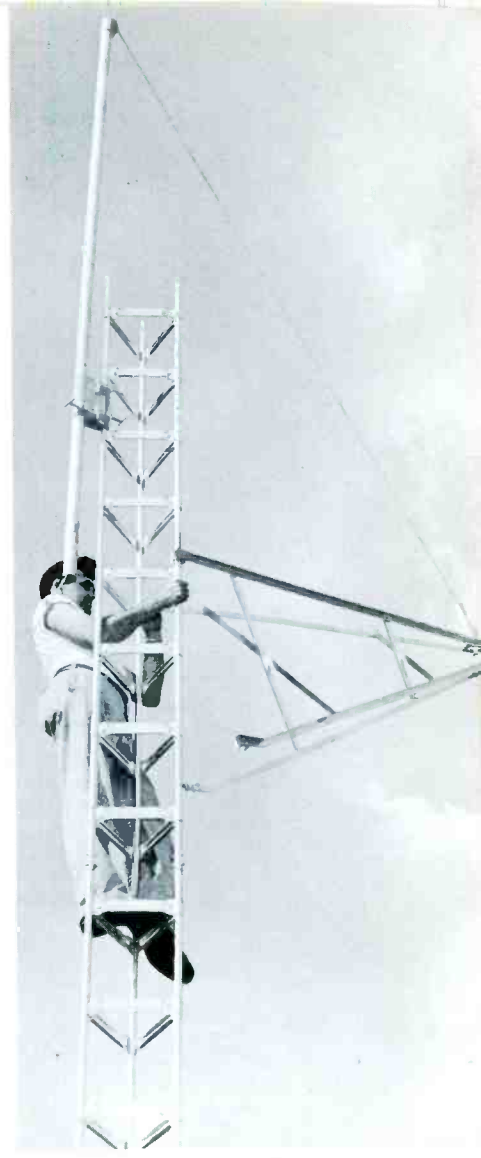

**Rotator and Antenna Mounting**

Attach both the rotator and the antenna to the top section of the tower before the latter is hoisted into place. The adapter post to which the rotator is being fastened permits the installer to use either an offset- or inline-type rotator. Before securing the rotator-adapter post to the tower, insert the mast through the tower and rotator and make sure the mast runs perfectly true through the tower center post. If a rotator isn't used, insert the drive-in bushing in the bottom of the center post to hold the mast vertical.

**Tower Erection Fixture.** The second 10' tower section can be installed without using the erection fixture, if the installer stands on the roof. After installing the second section and securing the bolts at the joint, the erection fixture should be mounted near the top of the tower and then pushed to its full height to permit the third section to be hoisted into place. The rope used must be more than double the height of the tower including the mast above. The fixture shown fastens to one leg of the tower and has a clamp to permit the boom to be raised or lowered. The boom is lowered before the fixture is carried to the desired point at the top of the tower and clamped to the outer leg. Then, the boom is raised to its full height and secured with the clamp. Before the fixture is raised to the top of the next section, the boom is lowered to about the position shown.

**Hoisting Tower Sections.** The rope runs up the hollow boom and over the pulley at the end. It is tied to the tower above the center so that it will hold the tower section in a vertical position. This permits the erection fixture to be mounted below the top of the tower, while allowing the tower section to be hoisted above the mounted tower. The installer on the tower should guide the section being hoisted and prevent it from bumping into the house or tower.

**Side-Arm Mount.** If more than one antenna is to be mounted on a single tower, it may be convenient to use a side-arm mount to permit one or both antennas to be individually rotator-operated. The side-arm mount should be guyed (not shown) with two wires to prevent twisting of the main tower in high winds. Be sure to follow the manufacturer's recommendations as to tower height and guying.

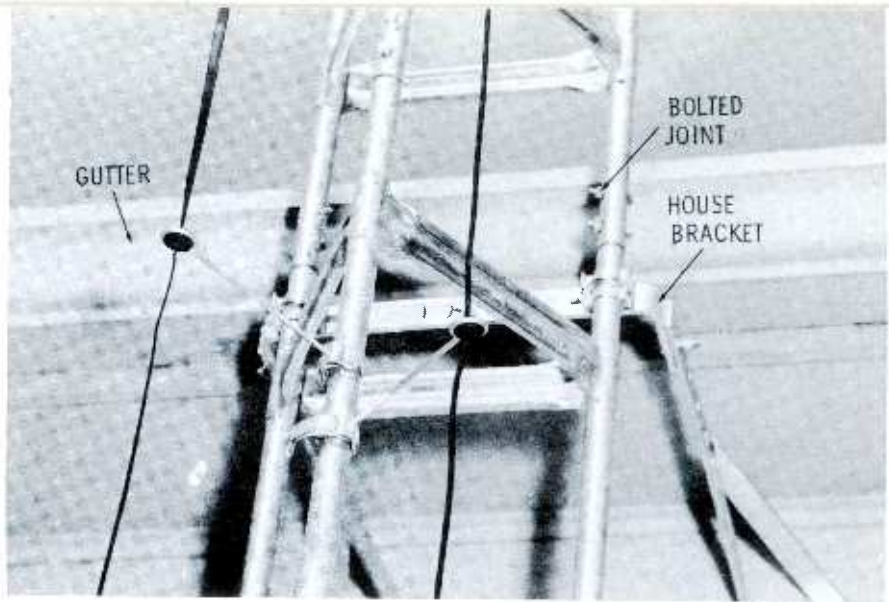

### Securing the Down-Lead

The lead-in wire can be supported on 7" stand-off insulators and routed down the outside of the tower, or supported on 5" units and routed down the inside of the tower. The rotator wire can be supported on any size stand-off either inside or outside of the tower. The inside location for the lead-in may be best because of the shielding offered by the tower.

This particular photo shows the house bracket secured just below the joint of the first two sections, placing the bracket at just about 10' above the ground level. This is as high as the bracket could be placed in this installation. The manufacturer of this particular tower recommends a minimum of 12' above the ground for an unguyed tower height of 47 feet.

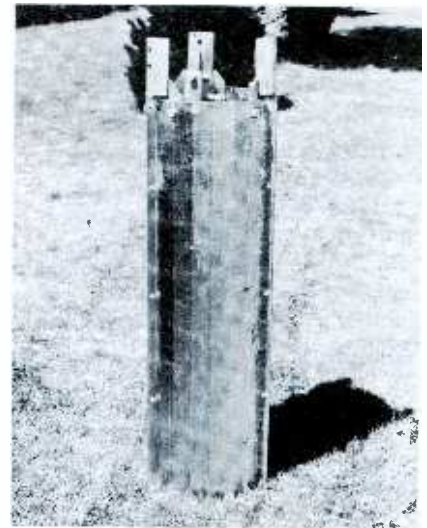
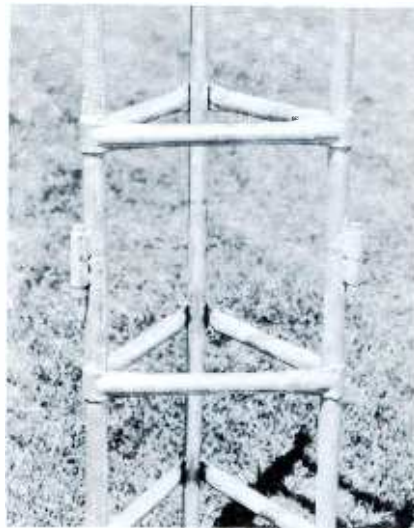

**Variations.** Instead of joints with bolts through the legs, some towers employ welded-on ears and a single bolt for each leg of the tower, making the joints the strongest points in the legs.

One mounting variation, called a culvert mount and installed without concrete, uses a galvanized cylinder about 4' long as a base section. The first tower section should be fastened to the mount before leveling or starting to replace the fill. This must be done to avoid distorting the cylinder due to pressure of the tamped earth. Make sure the bottom section of tower remains plumb during the tamping operation.

Another mounting variation employs a 3' section of tower in a suitable amount of concrete. Note that the short tower section should extend completely through the concrete and into a few inches of gravel. This is necessary to provide drainage for moisture that might otherwise collect in the hollow tower legs. Be sure to check the base section for level and plumb after the concrete has been poured.

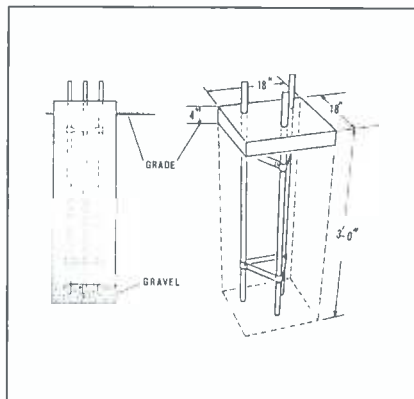

### Hoisting Preassembled Top Section

A 5" top section is employed so that the antenna can be installed on the ground where detailed work is much easier. Be sure to fasten the lead-in wire to the antenna on the ground; the rotator wire can be fastened later. The rope is tied to the smaller tower section and then passed around the mast section to hold the assembly upright.



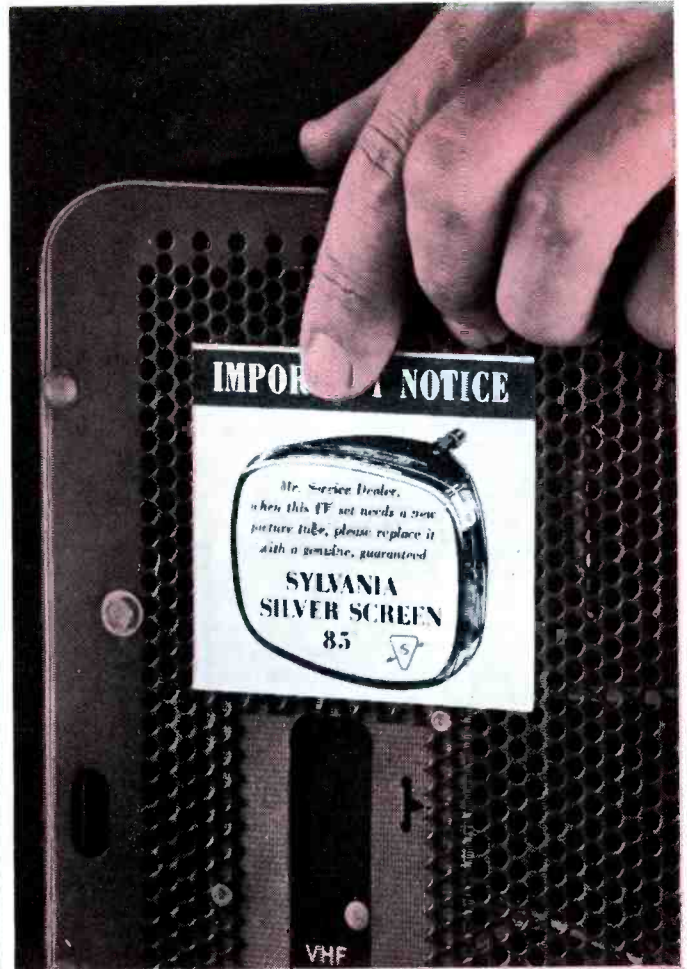
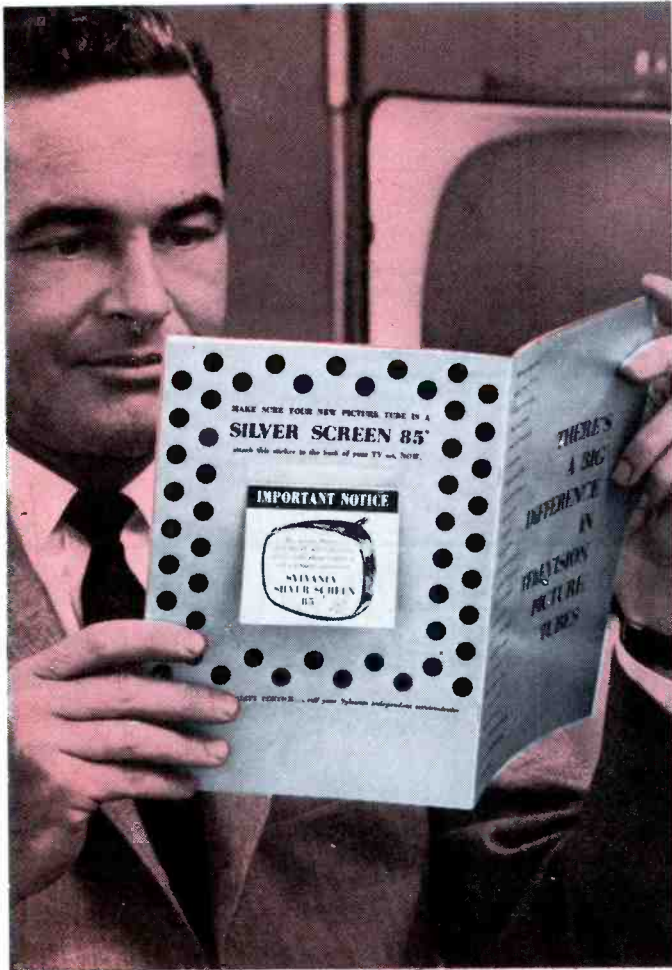

This label is your signal that a value-minded customer has been sold up to Silver Screen 85.

New consumer booklet from Sylvania helps you

## SELL UP TO SILVER SCREEN 85

Free booklet tells the story of Silver Screen 85's superior performance—  
detachable sticker lets the consumer tell you he's *presold* on Silver Screen 85

Leave a copy on every service call or make a complete mailing to your customers and prospects. Either way, Sylvania's new booklet, "There's A Big Difference In Television Picture Tubes," can help you sell up to more profits through more Silver Screen 85 sales.

In layman's language, this booklet details the difference between Silver Screen 85 and cut-rate off-brand tubes. It's chock-full of facts as they were revealed in Sylvania's recent test of a

nationwide sample. What's more, there's a handy sticker on the back of each booklet for the customer to attach to the back of his TV set. This is your signal that he's *presold up to* Silver Screen 85.

Get on the bandwagon. Let Sylvania help you sell up. Give each of your customers and prospects a copy of this new booklet. It's available free, complete with mailing envelope, from your Sylvania Distributor. Or write for a sample copy.



Bill Shipley's your No. 1 Salesman in the industry's biggest consumer advertising campaign.

 **SYLVANIA**

SYLVANIA ELECTRIC PRODUCTS INC.  
1740 Broadway, New York 19, N. Y.  
In Canada: Sylvania Electric (Canada) Ltd.  
University Tower Bldg., Montreal

LIGHTING • TELEVISION • RADIO • ELECTRONICS • PHOTOGRAPHY • ATOMIC ENERGY • CHEMISTRY-METALLURGY

# guide to...

## EUROPEAN TUBES *by Thomas A. Lesh*

If you are planning to lay in a stock of tubes for European-made radios and hi-fi amplifiers, you should concentrate on the types listed in this chart. They will take care of the great majority of foreign-tube replacement needs.

Tubes having readily-available American equivalents are listed in boldface type. The other tubes in the list are distinctly different from present U.S. types and cannot be replaced with any of the tubes customarily stocked by service shops. This situation caused some difficulties when foreign hi-fi equipment was first introduced into this country, but it has recently been eased by widespread importation of foreign tubes. Many U.S. distributors now stock exact replacements for a number of the tubes shown in the chart.

Several European manufacturers have registered their more popular tube types with EIA, and this accounts for the fact that many of the tubes in the chart have "American-style" alternate type numbers. Imported tubes may be imprinted with either or both halves of a dual-type designation.

As yet, domestic manufacturers are not making exact replacements for foreign tubes—except where noted in the chart. Tubes from overseas sources are steadily becoming more plentiful, but particular types are still sometimes hard to obtain at the moment you need them. Therefore, it's a good idea to pick up a few in advance if you anticipate servicing foreign-made equipment.

A great deal of information is packed into European tube-type numbers. Here are a few pointers on reading them:

The *1st letter* indicates the heater voltage or current. D—1.5- or 3-volt heater for battery-operated portable receivers. E—6.3-volt heater for operation with filament transformer.

The *2nd letter* indicates the number of electrodes in the tube according to the following code. If more than one letter comes after the first one, this means the tube has two or more separate sections.

- A—diode
- B—dual diode
- C—triode
- F—pentode (voltage amp)
- H—hexode or heptode
- K—heptode
- L—power pentode

The *1st number* indicates the type of base.

- 3—octal
- 8—miniature 9-pin
- 9—miniature 7-pin

*Other numbers* serve merely to distinguish between types.

*Example of code:* EBF89 is a dual-diode/pentode with a 6.3-volt heater and a 9-pin base.

TYPE	APPLICATION	TYPE	APPLICATION
DAF96/1AH5	AM det, audio amp	EF36—	Audio preamp
DC90—	FM RF amp	EF80/6BX6	AM/FM IF amp
DC96—	FM RF amp	EF85/6BY7	AM/FM IF amp
DF96/1AJ4	FM RF or IF	EF86/6267	Low-noise audio preamp
DF97—	FM RF or IF	EF89/6DA6	AM/FM IF amp
DK92/1AC6	Converter	EF804—	Audio preamp
DK96/1AB6	Converter	EL34/6CA7	Audio output
DL94 = 3V4	<b>Audio amp</b>	EL41—	Audio output
DL96/3C4	Audio amp	EL42—	Audio output; tape recorder bias osc
EAA91 = 6AL5	Ratio det	EL84/6BQ5	Audio output <sup>4</sup>
EABC80 = 6T8	AM det, AVC, FM ratio det, audio amp <sup>1</sup>	<b>EL90 = 6AQ5</b>	<b>Audio output</b>
EBC41 = 6AT6	AM det, AVC, audio amp <sup>2</sup>	EL95—	Audio output
EBF89—	AM det, AVC, IF or audio amp	EM34/6CD7	Tuning eye
EC92 = 6AB4	Low-power audio amp	EM71—	Tuning eye
ECC33 = 6SN7GT	Audio preamp	EM80/6BR5	Tuning eye
ECC81 = 12AT7	Audio preamp <sup>3</sup>	EM81—	Tuning eye
ECC82 = 12AU7	Audio preamp <sup>3</sup>	EM84—	Tuning eye
ECC83 = 12AX7	Audio preamp <sup>3</sup>	EM85—	Tuning eye
ECC85/6AQ8	FM RF amp & mixer <sup>4</sup>	EZ80/6V4	Full-wave rectifier
ECH81/6AJ8	AM mixer & osc, FM IF <sup>4</sup>	EZ81/6BW4	Full-wave rectifier
ECL82/6BM8	Audio amp & output	<b>EZ90 = 6X4</b>	<b>Full-wave rectifier</b>
		GZ34/5AR4	Full-wave rectifier
		KT66/5881	Audio output
		KT88/6550	Audio output

<sup>1</sup> Ratings of the diodes in the EABC80 and 6T8 are slightly different, but connections are the same. The EABC80 may also carry type number 6AK8.

<sup>2</sup> To use a 6AT6 in place of an EBC41, replace the original 8-pin miniature socket with a 7-pin type. The 6AT6 is not suitable for series-string circuits because its heater-current rating is incorrect.

<sup>3</sup> The ECC81, -82, and -83 are "ruggedized" tubes designed for a lower level of microphonism and hum than the 12AT7, 12A47, and 12AX7.

<sup>4</sup> The ECC85, ECH81, and EL84 are almost invariably used in West German AC-powered radios; EL84's are also used extensively in both foreign and domestic hi-fi amplifiers.



# now from Electro-Voice, compatible stereo power point cartridges for general replacement!

Mass-market stereo is here . . . now! Stereo tape gave the public a taste of the market. Dramatic—enormously stimulating—but limited to the esoteric few by cost and complexity. Overnight, the simultaneous perfection of stereo records and E-V Compatible Stereo Cartridges, made MASS stereo sales a practical reality . . . providing years of vast new profit potential for the service industry. New radio-phonograph lines will feature stereo. National sales campaigns by virtually every phonograph manufacturer will give the impact of millions of advertising impressions every month.

Capitalize on this demand now with E-V's new popular-priced compatible stereo Power Point. With the exception of "kiddie type" high-voltage cartridges, E-V's 60 Stereo Power Point Series can be your universal replacement . . . priced to guarantee you a profit . . . engineered to outperform existing monaural cartridges.

## Here are some of the answers to your questions concerning stereo:

**Q** How does the compatible E-V Stereo Power Point Cartridge differ from conventional cartridges?

**A** It plays both the new type stereophonic discs and conventional records. Inherent in its design is an improved monaural performance.

**Q** Are stereo discs compatible with conventional cartridges?

**A** Most monaural cartridges damage the stereo record. Modifying an existing phonograph with a compatible Stereo Power Point Cartridge makes it possible to play monaural or stereo discs monaurally. Adding a second speaker and amplifier will give your customer stereophonic sound.

**Q** What about the modification problems?

**A** Using an E-V Model 66, which is constructed so that its output is corrected to the RIAA curve, you match the equalization of virtually all modern radio-phonographs. Inserting the cartridge and mount is simple. It will fit any standard tone arm. Wiring the stereo-leads to a jack at the back of the set modifies it for *monaural operation*, makes it compatible with all types of records and ready for the additional amplifier-speaker.

**Q** What if the customer does not want to invest in the equipment for the second channel at this time?

**A** By installing the E-V Stereo Power Point Cartridge, his unit is completely modernized. He can use a television receiver or small AC-DC radio as the second channel. This gives acceptable stereo performance that can be improved later.

**Q** What about cost?

**A** The Electro-Voice Compatible Stereo Power Point Cartridge carries a list price of \$5.95 to the consumer. With a .7-mil diamond and 3-mil sapphire, the list price is \$19.50. Realistically priced to permit you to charge fair rates for your labor and still not present the consumer with prohibitive charges for the installation.

**Q** What if my customers are not ready for stereo? Can I prepare now to take advantage of the interest that will be whetted later by national advertising?

**A** The Electro-Voice Stereo Power Point is completely compatible physically with the monaural Power Point. *You can install the universal Power Point mount and wire it to the rear of the set. You can supply the customer with a monaural Power Point now and sell them a Stereo Power Point at a later date, along with the second speaker and amplifier.*

**Q** What about performance in comparison to existing monaural cartridges?

**A** The Model 66 delivers monaural performance comparable to present-day, high quality production cartridges. It reproduces stereophonic records with equal fidelity, providing average channel separation of 15 db.

**Q** What about record availability?

**A** Recordings by major record manufacturers are being introduced almost weekly. By mid-1958 thousands of selections will be available.

**Q** What if your customer is not a hi-fi enthusiast? Will stereo be of interest?

**A** The effect of stereo is just as dramatic to those who have no interest in high fidelity reproduction. It is the most potent selling tool you will ever have in your possession. Install it for one family in the neighborhood and you will automatically line up other enthusiastic customers.

**Q** How do you go about getting your Electro-Voice compatible Stereo Cartridge?

**A** Visit your distributor. Ask for E-V Stereo Power Point Model 66 with .7-mil stereo tip and 3-mil sapphire tip for monaural, or E-V Model 66DS with .7-mil diamond. All Electro-Voice Power Points work in turn-under mount Model PT3, \$1.00 list or the fixed-type mount PFT3, 50¢ list. If you don't know the name of your nearest distributor, please write.



## SPECIFICATIONS

<b>Response:</b>	20 to 15,000 cps
<b>Element:</b>	Ceramic (composite element*)
<b>Output:</b>	.5 volts
<b>Compliance:</b>	2
<b>Tracking force:</b>	4 to 6 grams
<b>Weight:</b>	2.5 grams
<b>Stylus:</b>	Diamond and sapphire—.7 mil
<b>Mount:</b>	EIA (RETMA) standard 1/2" and 7/16" centers
<b>Size:</b>	1/4" diameter, 3/4" long

\*Patent Pending

MODEL	STYLUS SIZE	LIST PRICE
61	.7 mil sapphire (stereo) .7 mil sapphire (stereo) Compatible	5.95
61D*	.7 mil diamond (stereo) .7 mil sapphire (stereo) Compatible	19.50
66	.7 mil sapphire (stereo) 3 mil sapphire (monaural) Compatible	5.95
66DS	.7 mil diamond (stereo) 3 mil sapphire (monaural) Compatible	19.50
PT3	Turn-under stereo mount	1.00
PFT3	Fixed type stereo mount	

### Minimum distributor pack:

61 and 66-6  
61D and 66DS-1  
PT3 mounts-6  
PFT3 mounts-6



**Electro-Voice** ELECTRO-VOICE, INC.  
BUCHANAN, MICHIGAN

CANADA: E-V of Canada Ltd., 73 Crockford Blvd., Scarborough, Ontario  
FOREMOST IN ELECTRO-ACOUSTICS . . .  
Microphones, Phono-Cartridges, High-Fidelity Loudspeakers and Enclosures,  
Public Address Speakers, Marine Instruments,  
EVI Professional Electronic Instruments and Military Material.



# GIVE ESTIMATES - STOP AGGRAVATION

I was relaxing Sunday afternoon when the phone rang. It was the widow who lives in the small apartment behind our TV shop. She pleaded, "Art, come right down here. There's a wild man here who demands his TV set back!"

I jumped in the car and drove over. I recognized the gent, a Mr. Jackson, whose receiver I had serviced personally a couple of months before. Evidently one of our outside servicemen had recently taken his set into the shop. I arrived to find him in a very angry mood.

He snarled, "One of your servicemen took my TV set into your shop when I wasn't home. Only my son was there. I thought the bill would be about ten dollars like when you fixed it at home. Then my wife was called yesterday by your office and they said it's thirty bucks!"

I had no other choice but to calm him down as best I could, take him into the shop, explain the charges and show the work done. It didn't help too much. He paid his bill angrily, picked up the TV and left — a lost customer.

Fortunately for us, this doesn't

happen very often. The big hitch in this chassis job was the fact that there was no one of responsibility home when the chassis was pulled—only a teenage boy. If someone had been home, this situation never would have occurred, for today we give estimates to forestall any such customer reactions.

A few years ago I went through my "inactive customers" file and discovered an interesting fact. The persons who become members of that file were, for the most part, people who had shop jobs. Another fact uncovered was that the people in the file were the ones I remembered having some aggravation with.

I asked myself why there should be so much trouble about shop jobs. There was no problem with the skill of our technicians. Where, then, was the sore spot? I came up with an answer. Our firm had no set policy on estimates of how much a shop job was going to be and how long it would take. Our servicemen, when they ran into a shop job, would say, "It's gotta go," and that was it. The set owner was left with the frighten-

ing mystery of "How much is it going to cost?" and "When will I get my TV back?" The optimistic people, in the majority, were always miserable during the three or four days the repair took, and then were shocked with the bill.

We decided to always give an estimate. It was as simple as that, and it's worked like a charm. The Mr. Jacksons of today are at a bare, bare minimum. Here are our estimate procedures.

## An Estimate on a Known Trouble

As soon as a TV man decides the TV he is working on in the customer's home needs shop work, he is faced with a loaded situation. Naturally, it's easiest to give an estimate on delivery time and total cost when you know what's wrong, but even then the situation can be ticklish and must be handled correctly.

In our area, where there are mostly ranch-type homes and very little traffic, we calculated that we had to get \$7.50 for a pickup and delivery plus \$10 for our basic bench fee. (These figures, of course, would vary in different sections of the country.) The ten spot includes the first hour's labor, a complete cleaning (tuner, controls, high voltage cage, etc.), adjusting (centering, horizontal frequency and phase, oscillator slugs, etc.), tube testing—both on a checker and in the circuit—plus any extra necessities individual chassis require for peak performance.

Anyway, that means when one of our boys pulls a chassis, the customer is immediately indebted to us for a minimum of \$17.50. In addition, there is usually some defect that will run the bill up even more. How do you tell a customer all this without losing the job?

When we know the trouble, we handle it this way.

I was examining a 16" RCA that had no audio. After the usual tube checks revealed nothing, I pulled the chassis half-way out of the cabinet and began trimming the sound discriminator transformer. To my delight, I began getting some sound. After rocking top and bottom a few times, the audio began to peak up. Soon, I had the sound clear and at a comfortable level, but the volume control was turned up all the way. I began tapping around the

• Please turn to page 74

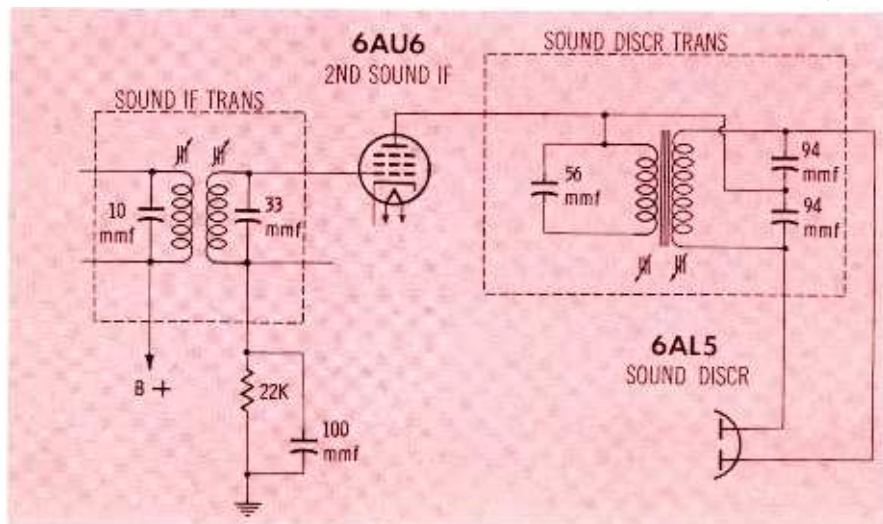
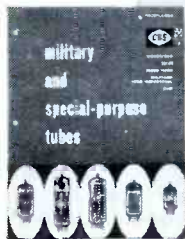
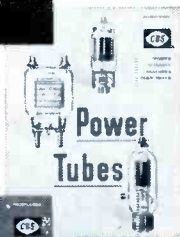
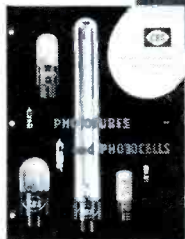

Fig. 1. Skittish audio was caused by intermittently shorted turns in IF cans.





# CBS-HYTRON GOES ALL OUT FOR THE SERVICE-DEALER



There's a reason for those awards to CBS-Hytron from dealer associations. CBS-Hytron has the welfare of the independent service-dealer at heart. And has proved it again and again: With a complete program promoting the independent service-dealer . . . including TV (Arthur Godfrey and Garry Moore) and national magazine advertising. With more CBS-Hytron time-effort-and-money-saving service tools. With scores of sales-promoting Business Builders. With two modern technical handbooks. With the most comprehensive and forward-looking line of replacement industrial tubes. With "inside" Tech Tips on tubes and semiconductors. With the original and most economical home-study Transistor Course. With a new aluminized 110-degree TV test tube. With illustrated technical talks for dealers.

With much more to come. And then tops them all with the advance-engineered tubes and semiconductors you can depend upon . . . products of the company that goes all out to serve the service-dealer most . . . CBS-Hytron.

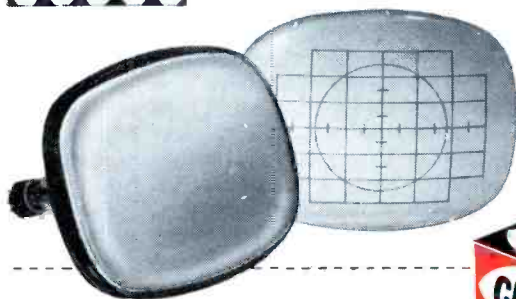
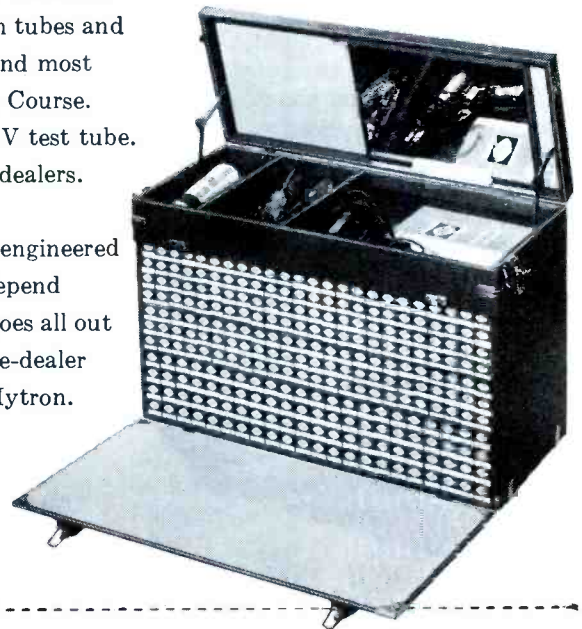

*More reliable products  
through Advanced-Engineering*

**CBS-HYTRON**, Danvers, Massachusetts  
A Division of Columbia Broadcasting System, Inc.



## POWER TRANSISTOR for AUTO TRANSISTOR RECEIVERS

This new Raytheon PNP alloy-junction germanium transistor helps Service Dealers do more auto transistor receiver servicing. Designed especially for the output stage in automobile receivers, the 2N155 is used in the Ford receiver, and is an ideal replacement transistor for the power units in many other car receivers. Here is a list of the many transistor types this one, high quality, low cost Raytheon 2N155 transistor can be used to replace:

AR5	2N242
2N176	2N250
TS176	2N257
2N235	2N285
2N235A	2N301

For the complete service dealer profit picture on Raytheon Transistors, get in touch with the Raytheon Tube Distributor nearest you.



*you meet* **ALL TYPES**  
*in this business of ours*  
by **W. C. Pecht**

There is a wide variety of technicians in the TV service industry. I might have said characters, but that could backfire.

One interesting type is the easy-going, lazy, optimistic kind of fellow. His approach is usually so amiable that the customer is unable to decide whether he hired a TV technician or a shill for a rest home. This guy never gets rich, never gets angry, never gets "dogs" and never gets ulcers. He has many friends and even more debts. He has great ideas to build his business but lacks the ambition to carry them out. If it were not for the generosity and understanding of the distributors, he might be in some other business, piling up friends — and debts.

Another chap you must have observed is the *intellectual*. He knows everything. If a customer asks him if it's cold outside, he goes into a detailed lecture on the high-pressure area that is exerting an undue influence on the dew-point, the sunspot activity that creates a long-range forecast of the movement of the jet stream, which bears watching whenever precipitation tends to exceed the norm for this time of year. The housewife is afraid to ask him what was wrong with the set because of the time he could consume explaining the intricacies of TV. The cost of this time enters her mind, and with true feminine logic, she confines her conversation to "How Much?"

Then we have the *savage*. When this boy attacks a problem, he really attacks! If a chassis doesn't come out of the cabinet easily, he puts one foot in a good spot and with brute force tears out an electrolytic can. He uses a old type of solder iron — usually the five-hundred watt type — and the hot barrel of that old worthy has finished off many a condenser, I'll tell you. When he carries a set into a home, his course can be traced by scratches on doors, nicks in table tops, lamps rocking like metronomes, and the sound of the family dog making sympathetic sounds to a tromped-on tail.

Some of us are what might be termed the *absent-minded* type. All of us fit this classification in times of stress, but there are those who could be labeled such because the condition is permanent. This one will start out on a service call, forget the call memo with the address on it, have to look up the phone number of the shop to get the address, forget his change

purse, go out to look in the truck and forget where he left the truck. After finding the truck, the change purse and the address, he makes the call. The set has to be brought into the shop and when he brings it in after making two more calls, he can't remember the owner's name. The boss would fire him right now except for the fact that he knows the model and Photofact Folder numbers for every set that was ever built . . . and all the other employees' social security numbers. No — not his own number.

The guy to be really pitied is the *worrier*. He tries to figure out what's wrong with the set on the way to the job. With the few unrelated facts volunteered by the customer, he reconstructs the crime and arrives at a solution — junk it. He is not sure that his tube stock is adequate. He frets about the possibility that perhaps it will be too tough to fix in the home and the customer won't let him take it to the shop. The engine dies at a stoplight and his mental processes switch to the complications arising from being stalled at a busy intersection with a truck full of expensive equipment. When he takes the back off the set and finds one obvious bad tube, he worries about whether or not the customer is going to pay the bill without squealing.

The *promoter* is another type of serviceman we all know. He's ambitious; he knows a good deal when he sees one. Every tube manufacturer in the trade knows him by his first name; they should, because every month like clockwork this bird has a mutually beneficial deal on the fire, involving his brains and the manufacturer's money. His advertising puts Barnum and Bailey to shame. His ads declare that you are a social outcast if you don't call his company for service. They insinuate that the other service companies have B.O. and that romance is waiting for the lucky girl who buys one of their one-owner used TVs. He personally guarantees that every TV he repairs will have only grade A, first-class, government-approved electrons. His shop bulges with work, requiring a staff of forty people. He makes two trips to the bank every day in a brand new car, wears nice clothes, and is the sole support of three doctors. The department of revenue finds him most interesting — often.

Of course, you and I do not fit any of these descriptions — do we? ▲



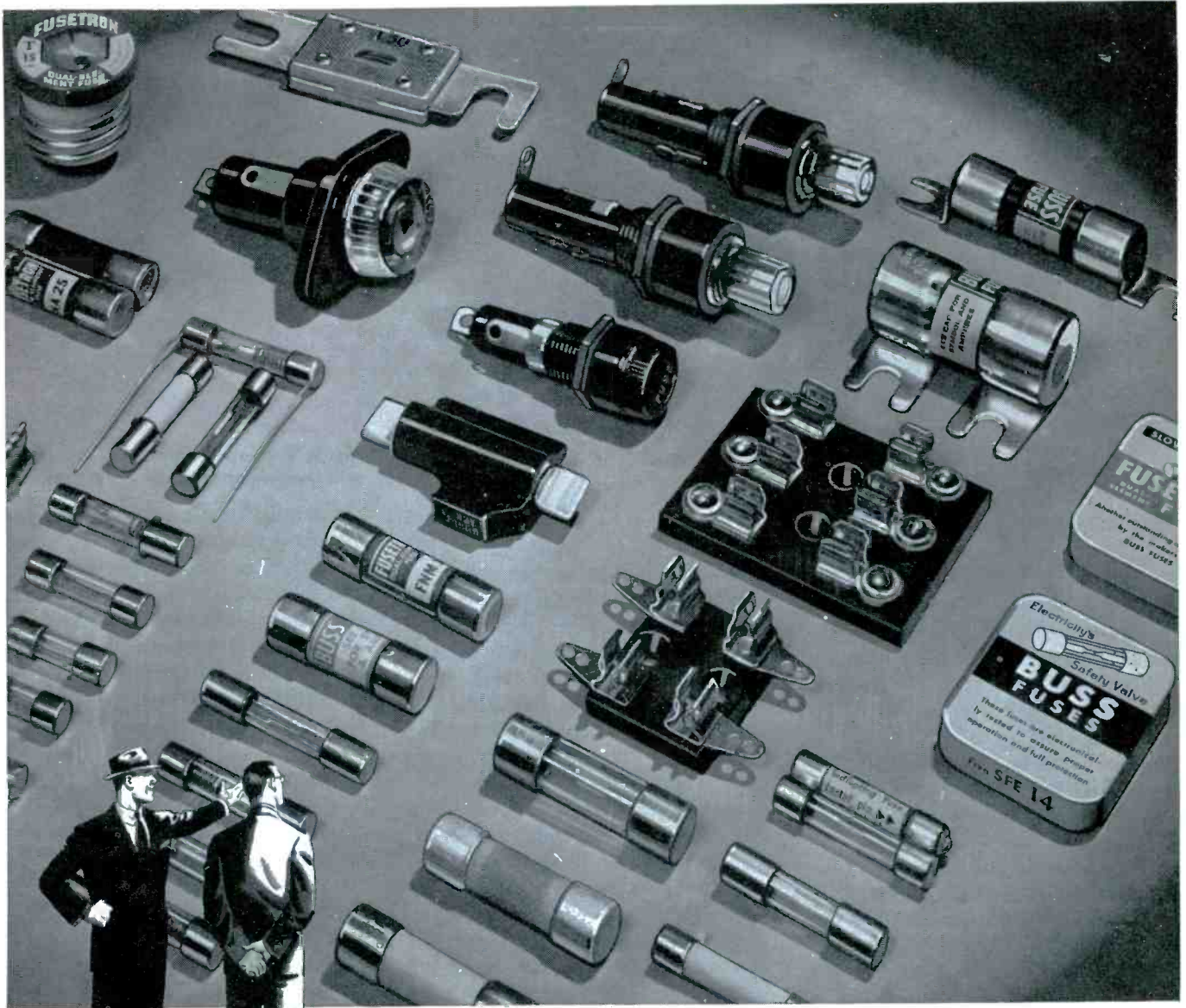

## **BUSS FUSES** *help you avoid adjustments and call-backs.*

Faulty fuses can cause trouble for you and your customers by failing to protect — or by blowing needlessly . . . but, with **BUSS** fuses you can be sure of dependable protection under all service conditions.

Every **BUSS** fuse you sell or install is tested in a sensitive electronic device. Any fuse not correctly calibrated, properly constructed and right in all physical dimensions is automatically rejected.

That's why **BUSS** fuses provide maximum protection against damage due to electrical faults. Users are safeguarded against unnecessary repair bills, — and your reputation for quality and service is protected.

Equally important, **BUSS** fuses eliminate needless blows that irritate users and require adjustments or call-backs on the part of sales and service organizations.

Protect yourself against faulty fuses causing trouble by relying on **BUSS** fuses. To meet service needs, there is a complete line of **BUSS** fuses available.

*For more information on the complete line of **BUSS** and **FUSETRON** Small Dimension Fuses and Fuse-holders . . . Write for bulletin SFB. Bussmann Mfg. Division McGraw-Edison Co. University at Jefferson, St. Louis 7, Mo.*

***BUSS** fuses are made to protect — not to blow, needlessly*



MAKERS OF A COMPLETE LINE OF FUSES FOR HOME, FARM, COMMERCIAL, ELECTRONIC, AUTOMOTIVE AND INDUSTRIAL USE.



# servicing NEW DESIGNS

by Thomas A. Lesh

## Set and Forget

One of the latest wrinkles in TV design is a tuner with a mechanical arrangement that can be preset by the customer so that each channel will automatically be fine-tuned to his liking. The basic idea (similar to that of push-button tuning in car radios) is to relieve the set user of a considerable amount of dial-twiddling.

One example of a tuner with preset fine tuning is the KRK72E unit in a new RCA Victor 21" TV set, Model 21D9475. As shown in Fig. 1, a system of gears is associated with the shaft of the fine tuning control. When the shaft is pushed in, these gears are engaged with one of 12 small gears (one for each channel) mounted on a wheel clamped to the main tuner shaft. The small channel

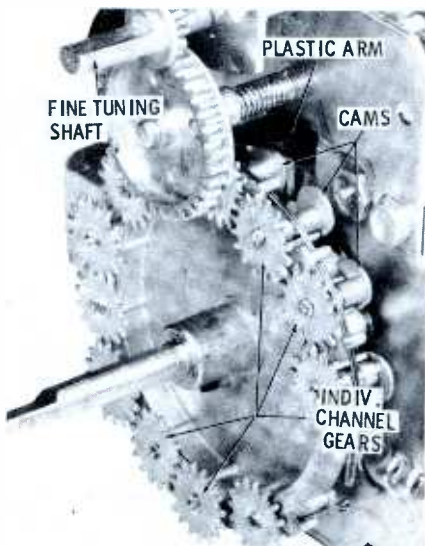

Fig. 1. Gears in new RCA tuner allow tuning to be preset for each channel.

gear can be set to any desired position, and it will remain permanently in this position after the operator disengages the drive gears by releasing the fine tuning knob. Each of the gears is connected to a cam, the position of which is changed whenever the gear is turned. Riding on the outer edges of the cams is a spring-loaded plastic arm that governs the position of the fine-tuning capacitor.

This capacitor itself is quite unusual as you can see in Fig. 2. One plate consists of metal and fiber discs, bonded together and attached to the main tuning shaft inside the tuner. The other plate consists of a metal finger, anchored to the tuner chassis at one end and crimped into a U shape at the other. This "U" fits loosely over the lip of the disc, and the finger is moved to and fro by the plastic arm in order to vary the area of the disc included within the "U."

The fine-tuning capacitor in RCA's other new 21" TV sets is similar in construction, but the plastic slider is driven directly by the fine tuning control instead of by the gear-and-cam arrangement.

The tuner with preset fine tuning also includes a full complement of oscillator adjustment slugs of the regular type, so that the technician can take care of the occasional case where the range of the fine-tuning capacitor is insufficient to bring in the clearest possible picture on certain channels.

## Other Features of '59 RCA Sets

In RCA Victor's new Chassis KCS121 and -122 (21" TV sets),

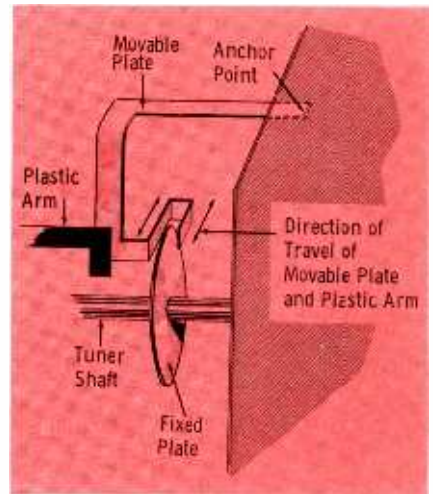

Fig. 2. Cam-operated plastic arm governs position of RCA fine tuning control.

the parallel tube heaters are divided into three groups—each with a separate fuse consisting of a length of fine-gauge wire in the feed line from the filament transformer. In case one of these fuses is blown, only a portion of the tubes in the set will go out. This makes the cause of a current overload much easier to find than if all the tubes were protected by a single fuse.

Tubes are grouped as follows in Chassis KCS121: On supply line "X," all IF's and audio output; on "Y," all other tubes in the sound, tuner, vertical, sync and video sections; on "Z," all tubes in the horizontal section. The grouping is different in KCS122: IF's only on "X," tuner and horizontal sweep tubes on "Y," and all others on "Z."

The latest 14" portable from RCA (Chassis KCS120) is similar to the KCS111, the major exception being that the new model is fully transformer-powered and uses a 5AS4A rectifier (see Fig. 3). Last year's set had selenium rectifiers and 450-ma series-string tubes.



Fig. 3. Latest RCA 14" portable features power transformer and 5AS4A rectifier.



# Now! **PHOTOFACT** Helps You Lick Printed Board Troubles in Seconds!

exclusive new Sams **CIRCUITRACE\*** feature eliminates costly hunting for test points...no more maze to trace...no need to flip-flop board...makes printed board servicing fast and easy

## HERE'S HOW **CIRCUITRACE\*** WORKS FOR YOU:

**1** All test points are clearly shown on the schematic and each is plainly coded...

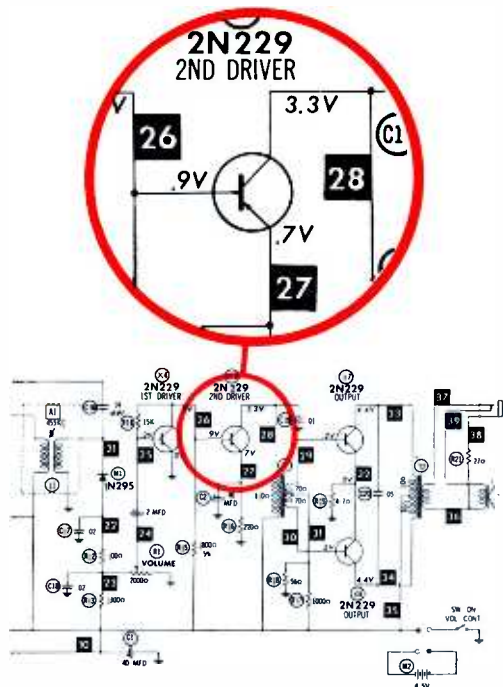

**2** The test points are similarly coded on the printed board so you instantly know where to apply the test!

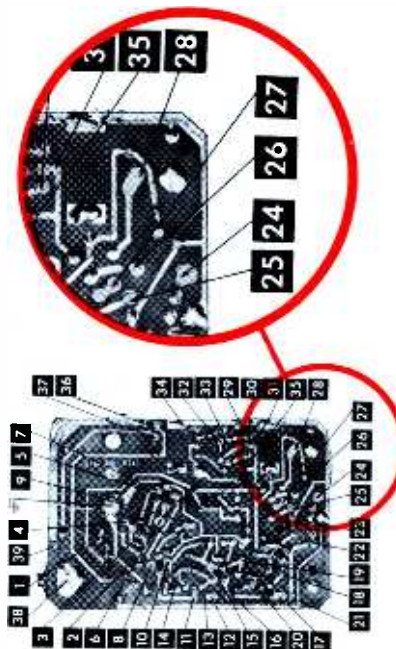

## **EXCLUSIVE** **CIRCUITRACE\*** IS NOW A REGULAR FEATURE IN **PHOTOFACT**

Write for Free PHOTOFACT Folder showing actual application of the CircuiTrace system. See for yourself how PHOTOFACT makes you an expert on printed board servicing—enables you to earn more by giving you exclusive time-saving help like this.

### **NOW—MORE THAN EVER**

YOU need PHOTOFACT! It's the best way to keep up with servicing trends, to maintain your position of leadership, to insure and build your earning power. Be a regular monthly subscriber to PHOTOFACT. Sign up with your Distributor.

**subscribe to PHOTOFACT today...**

**HOWARD W. SAMS & CO., INC.**  
2201 E. 46th Street, Indianapolis 5, Ind.

- Send FREE PHOTOFACT Folder showing CircuiTrace
- I am interested in a regular subscription to PHOTOFACT

My Distributor is: \_\_\_\_\_

Name \_\_\_\_\_

Address \_\_\_\_\_

City \_\_\_\_\_ Zone \_\_\_\_\_ State \_\_\_\_\_

# SAVE UP TO 22%

on a genuine Argos Tube Caddy®... newly designed "Pacemaker" models for the thrifty buyer... ruggedly built with Argos

*Craftsmanship in Cabinets*

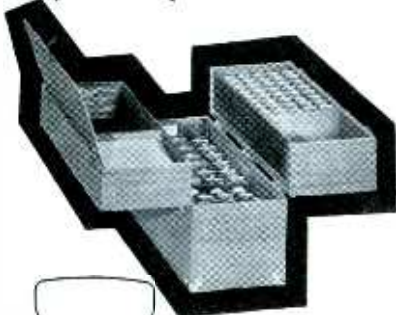

*Pacemaker*  
tube caddy

TC-100  
**\$12<sup>35</sup>**

Quickly pays for itself. Holds up to 262 tubes, plus tools, meter, etc. Same size as Argos "Carry-All" Tube Caddy.



*Pacemaker Jr.*  
tube caddy

TC-200  
**\$8<sup>95</sup>**

Low cost Tube Caddy for quick trips. Holds up to 143 tubes, plus tools, meter, etc. Same size as Argos Tube Caddy "Junior."

©Registered TM of the Argos Products Co., originator and sole manufacturer. Ask your Distributor NOW!

**Argos**  
PRODUCTS COMPANY

DEPT. P, GENOA, ILLINOIS

Also wall and corner baffles, hi-fi speaker enclosures and kits.

The components on the main vertical chassis have been somewhat rearranged to accommodate the power transformer, but the "sidesaddle-mounted" printed wiring board is practically the same as the one in the KCS111. Note that the conductor side of this board is covered with a metal shield that will occasionally have to be removed to get at some of the connections on the board. Removal involves taking out five screws around the edges of the shield and unsoldering several connections between tabs on the shield and conductors on the board.

### All-Transistor Auto Radio

Motorola's first completely transistorized automobile radio, Model GV-800, is a "universal" type that can be used in many different types of cars. Adjustable control-shaft spacing simplifies the problem of installation.

A total of 8 transistors is used. Six of these are low-power, plug-in types, and the other two are 2N176 power transistors just like those that have been employed in hybrid receivers. The radio includes a standard pushbutton tuning mechanism, and conventional wiring is used throughout.

Much of the circuitry in the GV-800 is comparable to that found in typical transistor portable radios. For example, the set has a 2N140 converter, two 2N139 IF's, a diode detector, and a 2N109 as 1st audio amplifier. There are a few unusual features within these stages; for example, the oscillator circuit contains two ceramic capacitors with negative temperature coefficients in order to compensate for the wide variations in temperature likely to be encountered under the dash of an automobile.

This auto radio does include one important item seldom found in portable receivers—an RF amplifier (see Fig. 4). The 2N247 in this stage is a "drift" transistor with a base region that is specially modified to provide more gain at high frequencies. The 2N247 has a fourth lead which is internally connected to the metal case of the unit. In the GV-800, no external connection is made to this lead.

In Fig. 4, note that the collector of the 2N247 is returned to ground through the output transformer, and

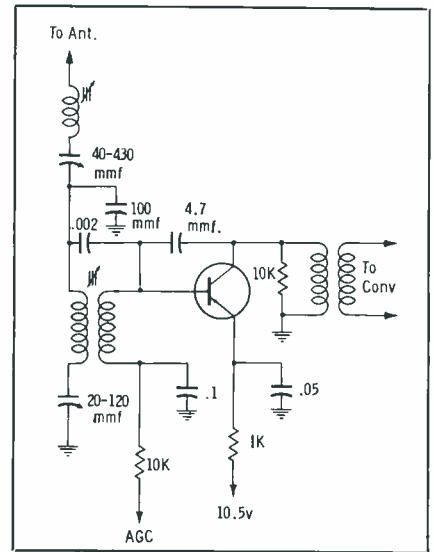

Fig. 4. Motorola Model GV-800 auto radio has drift transistor as RF amplifier.

that the emitter is returned to a 10.5-volt source. All the transistors in the set, being p-n-p units, are connected in a similar manner across the source voltage. Fig. 5 illustrates how the supply voltages are obtained for the various emitter circuits. Remember that the base voltages must be slightly less positive than the related emitter voltages for proper biasing. Some stages obtain the correct base voltage from a divider network across the "A" source, while others depend on the AGC system for bias.

The AGC circuit, shown in Fig. 6, is one of the most unusual features of this radio. A separate crystal diode is used as a detector. Its anode receives a positive voltage from the junction of R1 and R2, resulting in diode conduction and the charging of C1. The voltage on the top plate of this capacitor, although negative with respect to the 10.5 volts on the bottom plate, is still about 9 volts

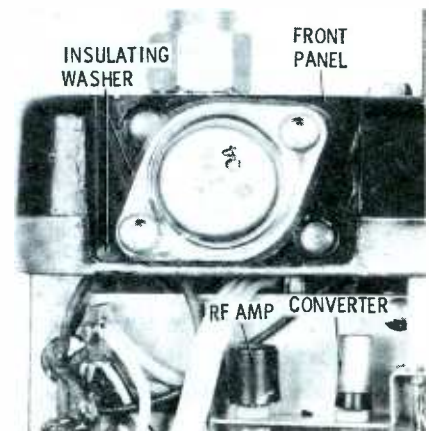
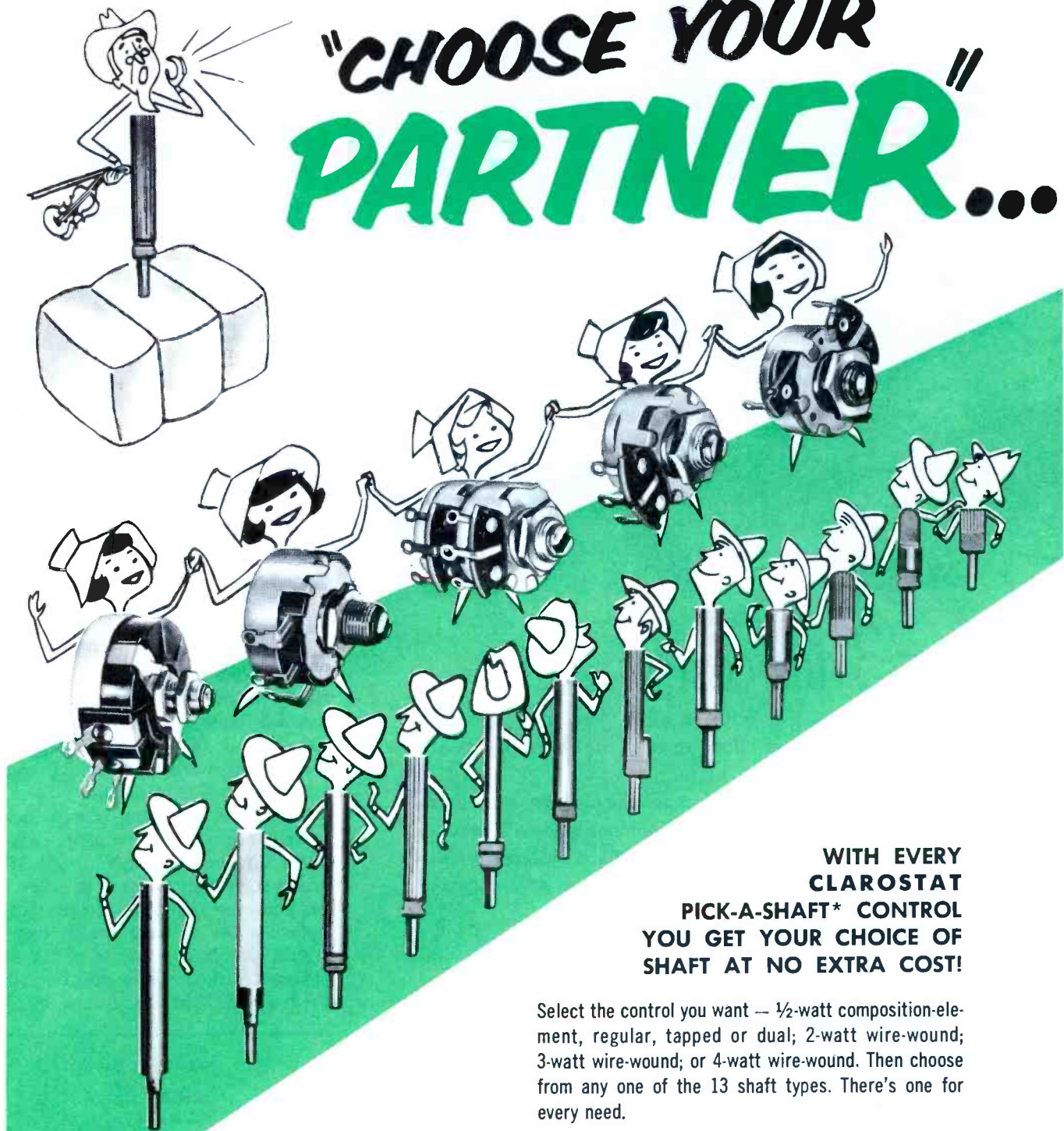

Fig. 5. Various voltages are fed to emitter circuits in GV-800 from "A" supply.



# "CHOOSE YOUR PARTNER..."



WITH EVERY  
CLAROSTAT  
PICK-A-SHAFT\* CONTROL  
YOU GET YOUR CHOICE OF  
SHAFT AT NO EXTRA COST!

Select the control you want — ½-watt composition-element, regular, tapped or dual; 2-watt wire-wound; 3-watt wire-wound; or 4-watt wire-wound. Then choose from any one of the 13 shaft types. There's one for every need.

**Ask your Clarostat Distributor...**

\*Reg. U.S. Pat. Off.



for **P**erformance... **D**ependability... **Q**uality...

*Controls and Resistors*

**CLAROSTAT MFG. CO., INC., DOVER, NEW HAMPSHIRE**

In Canada: **CANADIAN MARCONI CO., LTD., TORONTO 17, ONT.**

# SUMMER vi-fi SPECIAL!



- 3 for cost of 2

Or buy 4 and receive 2 free with an extra "special" discount! Under either plan, you can't afford to miss the extra profits of this "Summer Vi-Fi Special"!

Vi-Fi is the *only* indoor antenna that has the modern, slim lines of the new tv sets. Vi-Fi is the *only* indoor antenna with transformer coupling and variable inductors for sharp pictures. Vi-Fi is always a good buy; this "Summer Special" makes it the biggest antenna bargain ever!

Your Authorized AMPHENOL Distributor has all the details. See him right now!

THE BIGGEST  
ANTENNA  
BARGAIN  
EVER!

SEE YOUR

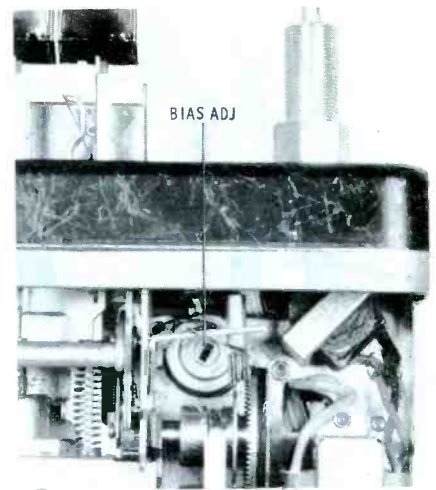

Fig. 6. AGC system of Model GV-800 includes separate crystal diode rectifier.

positive with respect to ground. All of this voltage is applied to the base of the RF amplifier, and most of it is applied to the base of the first IF.

A sample of the incoming signal is coupled from the output of the second IF to the cathode of the AGC diode. Conduction of the diode then varies according to changes in signal strength, and the charge on C1 is modified in such a way that a strong signal causes a reduction in forward bias (i.e., base-to-emitter voltage) of the controlled stages. With less forward bias, the RF and 1st IF stages have less gain.

After the incoming signal has passed through the first audio amplifier, it goes through a 2N270 driver stage that raises it to a level sufficient for application to the output stage. As we have already mentioned, this final stage has much in common with the push-pull circuits used in some hybrid-type auto radios

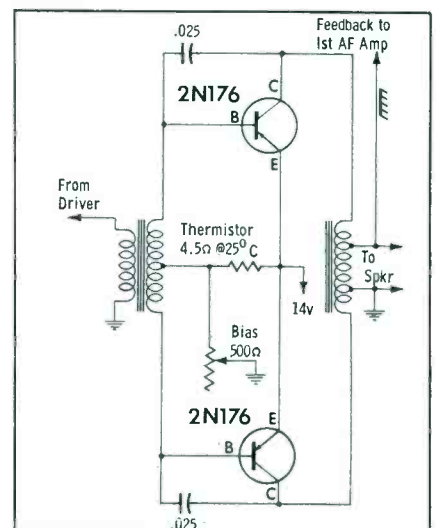
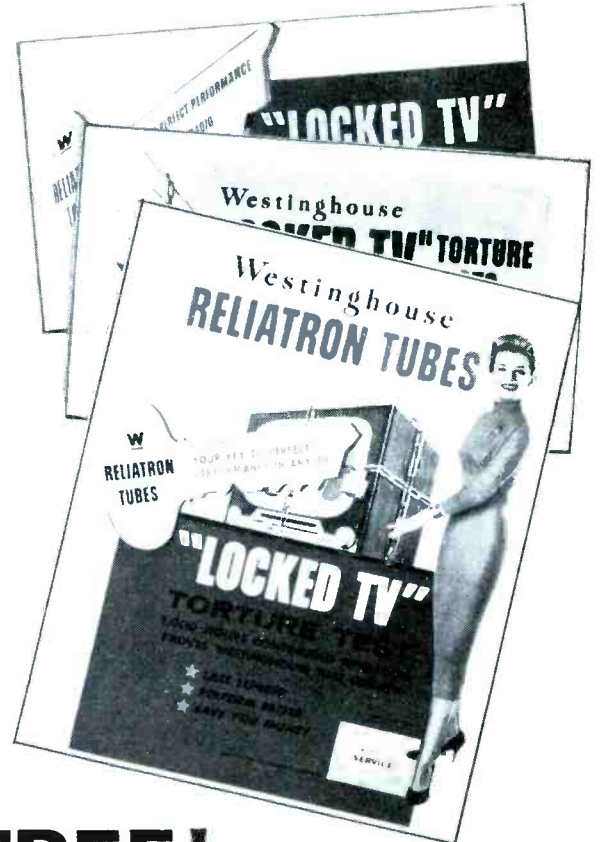
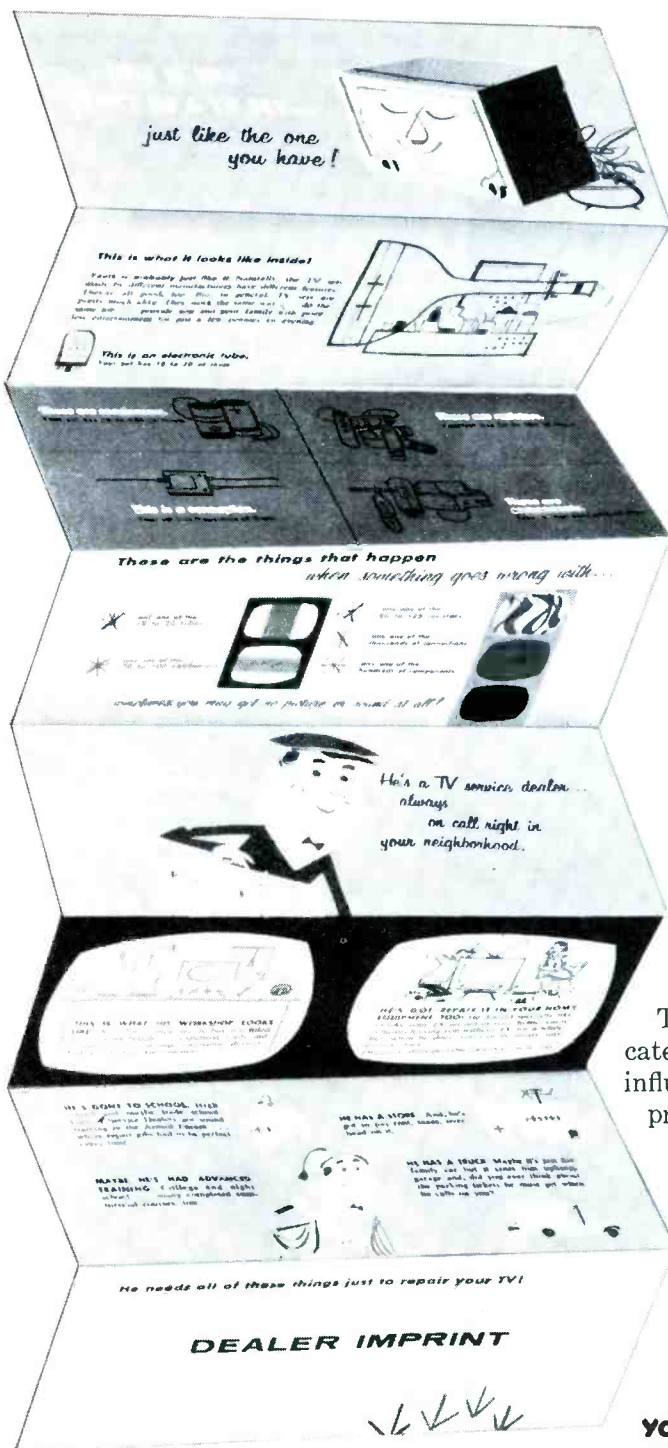

Fig. 7. Output transformer of GV-800 is in collector circuit of push-pull stage.



# WESTINGHOUSE HELPS TV SERVICEMEN "GET A FAIR SHAKE!"



## FREE!

### "Build Consumer Confidence" Promotion

Today most people are unaware of the buy they get in TV and radio service. Now, Westinghouse helps you educate them with a program designed to win you friends and influence sales! You get a complete kit free! Keystone of the promotion is the mailing piece shown left. It describes how many hundreds of parts there are to check . . . how much knowledge it takes to be a serviceman . . . equipment costs . . . etc. It shows how TV servicemen, like doctors and lawyers, constantly study to keep up with advances. In addition you get window displays, streamers, everything you need—all free! Don't wait, put this promotion to work for you now . . .

**CALL YOUR WESTINGHOUSE DISTRIBUTOR**

**YOU CAN BE SURE...IF IT'S Westinghouse**  
Electronic Tube Division - Elmira, New York

built within the past few years.

One highly important change has been made, however (refer to Fig. 7). Where Motorola used to fasten the collector of a 2N176 directly to chassis ground in order to simplify heat dissipation, they have now switched to a practice that is more generally followed in the industry: The collector is insulated from chassis, and the output transformer is included in the circuit between collector and ground.

One of the power transistors is shown in Fig. 8. The thin fiber in-

ulator is barely visible under the body of the transistor. To improve the heat-transferring qualities of this insulator, a special non-conductive grease is spread on both sides before installation. It must be renewed if the insulator is replaced.

The 2N176's are color-coded to indicate that matched units are used in the push-pull output stage. In the unit we studied, the type designation was printed in green.

Like other transistor-powered car radios, the GV-800 has a bias adjustment that must be reset when-

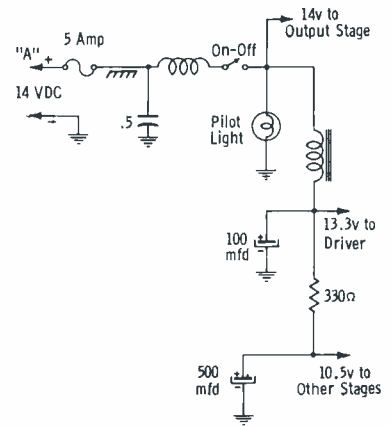

Fig. 8. Motorola power transistors are now insulated from chassis by washer.

ever output transistors are replaced. The bias control is located on the underside of the radio as shown in Fig. 9. It should be turned to the maximum counterclockwise position and then slowly advanced to establish a collector current of 300 ma with an input "A" potential of 14 volts. To monitor the collector current, unsolder the output transformer ground lead (black) and the speaker ground lead (brown); both of these will be found near an electrolytic capacitor adjacent to the 2N270 driver transistor. Connect one lead of a milliammeter to both these disconnected leads and the other meter lead to chassis.

General servicing procedures that apply to transistorized portable sets are equally suitable for the GV-800. Signal tracing and voltage checking are ordinarily the most successful techniques for locating defects. To protect the transistors, their base leads should not be shorted to ground; in addition, you should make sure that any power supply you use is filtered well enough for transistor applications. ▲

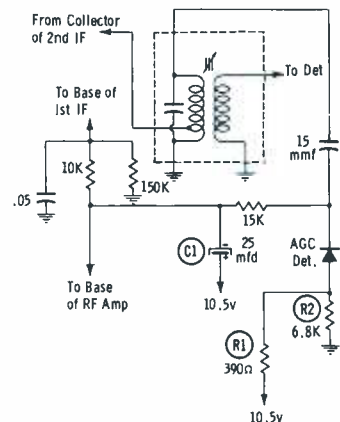

Fig. 9. Bias adjustment on GV-800 must be reset if output transistor is replaced.

3 Brand New Instruments Designed to save you time!

BY DOSS ELECTRONIC RESEARCH

## Electrolytic Substitute

Model D-600 \$8<sup>95</sup>

The D-600 ELECTROLYTIC SUBSTITUTE is designed to shunt test all electrolytic capacitors. A new, unique circuit allows the test to be accomplished without the charging surge, which often heals the defective electrolytic temporarily—thus destroying the test. Two ranges (10-40 MFD-450 V) (50 MFD up-450 V) provides test substitutes for all electrolytic capacitors; no surge switching; features neon indicator and special thumb switch.

## Sync Master

Model D-700 \$10<sup>95</sup>

The D-700 SYNC MASTER is designed expressly for all video, sync, sweep, and audio signal tracing. The SYNC MASTER may be matched to ANY oscilloscope—using only TV signals—by means of two built-in calibrating controls—low and high frequency compensation. Signal tracing accomplished without frequency discrimination and with minimum loading; ideal for setting synchroguide waveforms; adds frequency compensation and step attenuation (X10, X100) to scopes not having this facility.

## Hi Leak Analyzer

Model D-400 \$12<sup>95</sup>

Utilizing a sensitive, relaxation oscillator principle, the D-400 HI LEAK ANALYZER Probe is designed to quick-check capacitors for any condition of leakage or for an open circuit. Testing is accomplished by application of 100 volts D.C. to insure accurate and sensitive measurements. A built-in indicator makes the D-400 completely portable—just plug-in to any A.C. line and use. Tests leakage up to 500 megohms; tests capacitors for open circuit condition; tests leakage up to 500 megohms between cathode and filament of tubes.

ADVANCED Techniques of TV Troubleshooting

Order Now With A Money Back Guarantee

Please ship me at once, the following DOSS instruments:

D-600 Electrolytic Substitute \$8.95

D-700 Sync Master \$10.95  D-400 Hi Leak Analyzer \$12.95

Name \_\_\_\_\_ Co. \_\_\_\_\_

Address \_\_\_\_\_ City & State \_\_\_\_\_

My Distributor is \_\_\_\_\_ City \_\_\_\_\_ State \_\_\_\_\_

Note: Your Purchase will be credited to the above distributor (we cannot ship your instruments unless you specify your distributor)

DOSS ELECTRONIC RESEARCH • 820 Baltimore, Kansas City 5, Missouri

DOSS

ELECTRONIC RESEARCH

Also Manufacturers of the

D-100 Sweep Analyzer

D-200 Video Master

D-500 Slave Oscillator

820 BALTIMORE KANSAS CITY 5, MISSOURI



The Most Advanced TV ANTENNAS  
in the World!

**TRIO**<sup>®</sup>

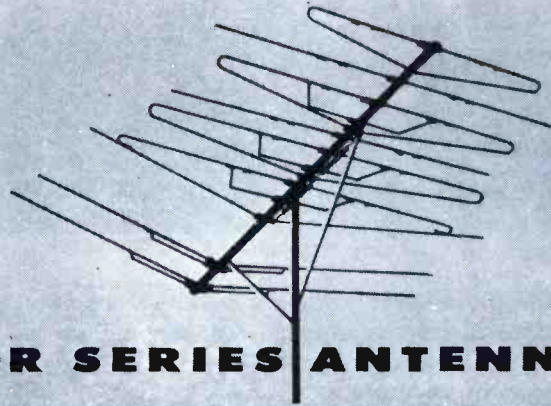

**ZEPHYR AND COLOR SERIES ANTENNAS**

Look for these  
**4 Great Features**  
in 1959

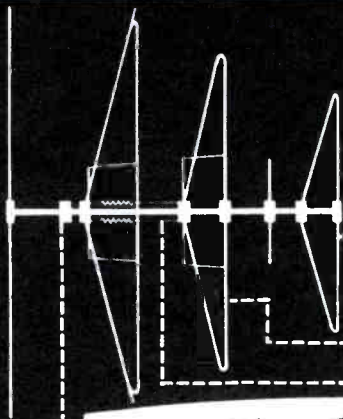

*Wing Dipole*

Today's most powerful dipole! Contains three active elements on the highs—forward Vee to the low band section—plus integrated director.

*Wing Director*

Today's most powerful director! A composite director designed to obtain results from the powerful Wing Dipole.

**no-strip**  
lead-in connector

Requires no stripping, no soldering, or wire holders—holds the complete insulated wire.

**dyna-coil**  
phasing

Increased performance from uniform transmission of signal strength of each active dipole in a multi-dipole system—**AND MAKES POSSIBLE COMPLETE FACTORY ASSEMBLY.**

Choose from . . . **TRIO'S COMPLETE LINE**

**COLOR ROYAL**—The ultimate in color television reception—or black and white.

**ZEPHYR ROYAL**—Extraordinary power and sensitivity.

**ZEPHYR PIONEER**—For extreme distance.

**COLORITE**—For color and black and white in areas formerly using conicals.

Sharpshooters, Conicals and Yagis

Patents: U.S. 2772413—Canada 541670

Copyright 1958, Trio Mfg. Co.



**TRIO**<sup>®</sup> *Manufacturing Company* GRIGGSVILLE, ILL.



**Stacking Up.** Since it is impractical to turn out a whole series of exactly identical parts in mass production, some leeway or tolerance must be allowed in dimensions and other specifications. Tolerances are made strict enough so that most finished assemblies will be well put together, but the law of averages catches up with an occasional unit and causes several parts that are "off" in the same direction to come together in the same assembly. Automotive engineers refer to this effect as "stacking up" of tolerances. It is most plainly visible in auto body sheet metal, where it can result in large gaps between panels or in a failure of trim strips to line up evenly.

Greater manufacturing precision or more rigid inspection are the only remedies, and both of these steps mean a sharp increase in production costs. Automation is just one of the steps taken by industry to minimize "stacking up," while still controlling costs.

TV manufacturing, being another assembly-line process, is subject to similar problems. Serious attempts are made to combat "stacking up"; for example, controls are added to circuits to compensate for this effect, as well as for aging. Nevertheless, operating conditions in an occasional circuit may be just far enough out of line to cause troubles—usually subtle or intermittent ones, at that. Since the symptom is usually due to the cumulative effect of several slightly off-value parts, the technician may not be able to remedy the situation by checking individual components.

The chance of running into this type of defect should not unduly alarm servicemen, since it is fairly uncommon. The service industry should be aware that "stacking up" can happen, however. If a persistent,

puzzling symptom (such as repeated tube failure in a particular circuit) is noticed in a nearly new set, the technician might try to analyze the affected circuit to see if a number of slight deficiencies could be snowballing into a full-sized case of trouble. Over-all checks of circuit operation, such as voltage and resistance measurements from tube pins to ground, are most helpful for this purpose.



**Catch Up.** Schedule still a little slack these days? Grab a cup of coffee in your free moments, pull up a stool, and reach for the service literature on new TV sets that have come out during the past year. This is an ideal time to get familiar with chassis layout, disassembly and adjustment information on these receivers, as well as production changes and service hints that have resulted from the first year's field experience with the sets. A little studying now will save you time later on in the season when you're more rushed.



**Transistor Tip.** For years, technicians have been successfully troubleshooting vacuum-tube circuits by taking a round of voltage and resistance measurements at all tube pins. Since the resistance between elements inside the tube is infinite, it can be assumed that the resistance reading obtained at each pin is equal to the total resistance of the external circuit from that pin to ground.

Transistor circuits are different! Within the solid body of a transistor, some finite value of internal resistance is present between any two

terminals. A low-resistance shunt therefore exists across each external circuit, making ohmmeter checks from terminals to ground almost meaningless. What's more, the internal resistances will change according to the value of applied voltage, and this means that different ohmmeters will give different readings unless their battery voltages are the same.

In order to get usable resistance readings, you will generally have to remove the transistors from the circuit. This is easily done if plug-in transistor types are used in the equipment being tested; but a high percentage of transistors unfortunately are solder-in types. The compact printed circuits in which transistors are usually installed, and the risk of overheating the transistors, are factors which make it very undesirable to unsolder any more connections than necessary.

Best way out of this situation is to rely on voltage checks and signal tracing until a defect has been pretty well localized. Then put the ohmmeter to work.



**Interruption.** When you are suddenly called away on some outside business during a complicated bench service job, do you have to stop and turn off all your equipment separately? If you do, then why not install a master switch which will handily shut off all power to the bench at one stroke? The time saved will be well worth the small amount of work and expense required.



**Lullaby.** A recent survey reports that about half of all consumers queried were interested in the idea of a clock-TV that would automatically turn itself off after a specified interval, in the same manner as a clock radio.

At least one such receiver is included among the new '59 models, and clock-TV's may become a familiar sight before long. In the meantime, service dealers might have some success in promoting an accessory consisting of a separate timer mechanism that could be inserted between the TV receiver and the power line.



# attention!

# *Winegard*

# TV antenna dealers

*coming your way — the biggest  
antenna promotion of the year!*

## Winegard's "Dealer Double Profits Program"

*down with the old! up with the gold!*

**T**o make this fall your biggest ever for TV antenna profits, just pick up the selling tools from Winegard! They're all wrapped up in the new Double Profit promotional package that gives you everything you need to pull the customers in — and sell twice as much to double your antenna profits.

It's a money-maker you can't afford to miss!

*coming soon!*



*see your jobber or write for full details*

## *Winegard Co.*

3009-9 Scotten Boulevard • Burlington, Iowa

## Using Service Literature

Service literature for electronic equipment is one of the most valuable aids available to the technician, and yet it is one of the least understood. The manner in which service literature is employed will, in a great many instances, determine whether the repair job is completed rapidly, or whether the set gets classed as a "dog." If you've had a "dog" in the shop lately, or if you aren't sure you know everything there is to know about using service data, read on, and learn how to speed up those service jobs by using all of the help provided in service literature packages.



### First Things First

If you are going to derive the maximum amount of good from data covering a specific piece of equipment, be sure you have *all* of the literature. This includes the primary package plus any subsequent production change bulletins. How do you go about assembling all this information? First, consult the latest index information for the literature you use, and locate the chassis number of the instrument. If a chassis number cannot be found, look up the model number of the complete unit. The reason for using the chassis number as the key for locating the proper service literature is that in many cases manufacturers have installed several chassis variations in the same model unit in the course of a production run, and only the chassis number will key you to the entire package of correct data. Remember that a *complete* package may not be found all in one place, but your index should tell you where the various pieces are filed.

It is best to obtain the literature package and go over its contents carefully before trying to disassemble unfamiliar equipment. This is especially true for newer TV receivers because assembly techniques have been changed radically.

### How to Use the Information

Now that you're sure you have all the data you'll need, let's see how it can be used to save time. Suppose you have a new portable in the shop and know the "works" must be removed, but you aren't sure whether the chassis comes out of the cabinet

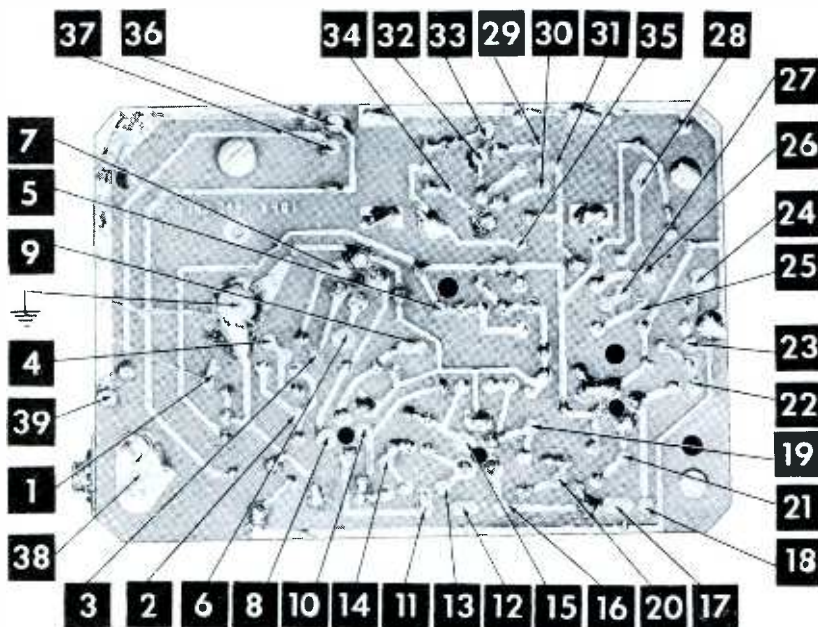
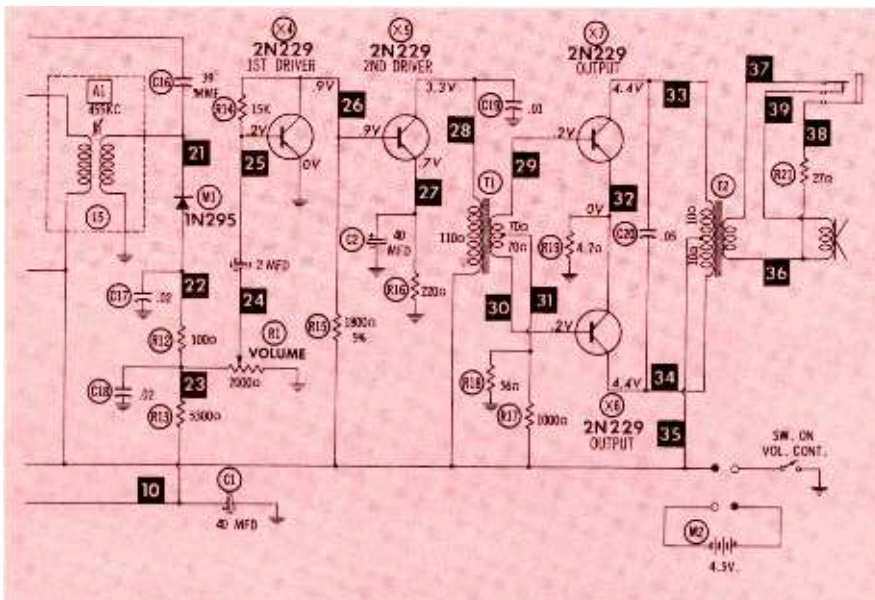
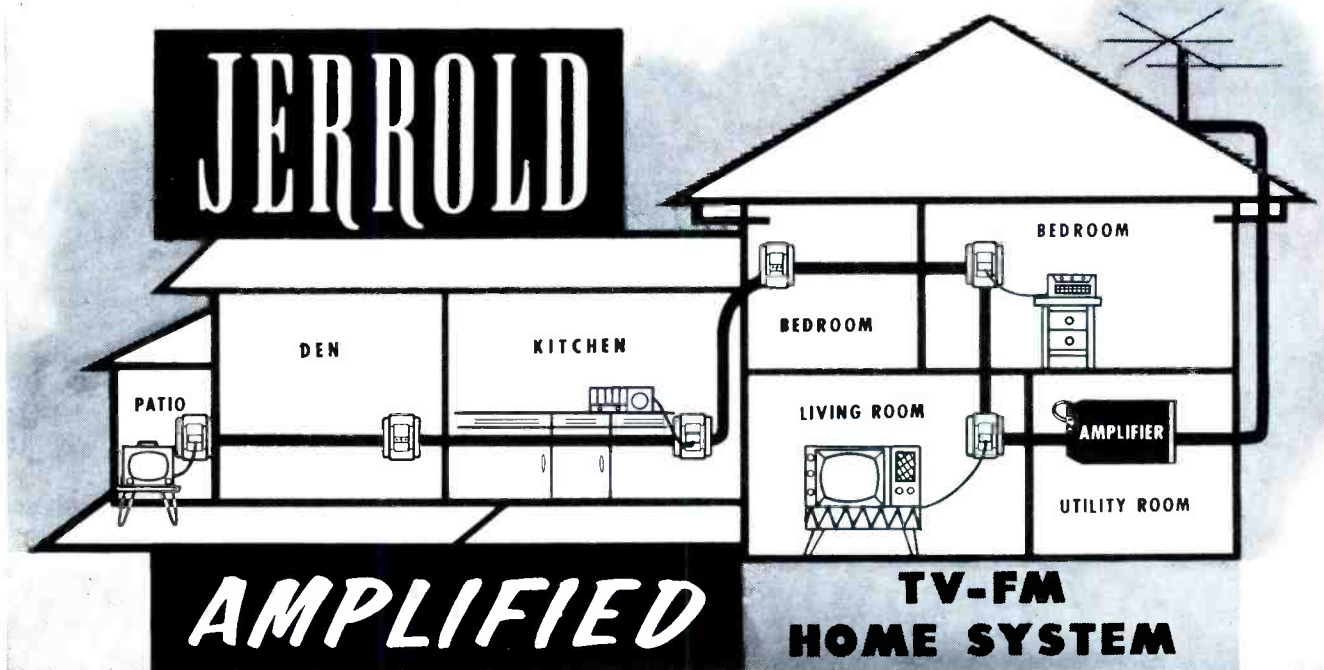

Fig. 1. CircuiTrace eliminates the need for tracing printed board connections.



# It's Here! The First **AMPLIFIED** PLUG-IN TV-FM HOME SYSTEM



- \* A Completely Engineered, Fully Amplified System —Not a Multi-Set Booster
- \* Simple...Solderless...300 Ohm Twin-Lead Installation
- \* Sets not "Tied Down", can be moved anywhere
- \* "Snow Free" TV and "Hiss Free" FM Reception

The FIRST truly engineered, amplified system designed for the home! Supplies *Hi Fidelity* reception to TV and FM receivers in any room! Makes TV sets truly portable... new TV and FM receivers can be added with a simple plug-in connection!

The Jerrold Home System features a low noise, high output, printed circuit amplifier that increases the TV and FM antenna signals 6 times (15 db). 300 ohm Twin-Lead is used to distribute the amplified signal throughout the home. Receivers are connected to the system by newly designed Home Outlets and Plugs.

The Jerrold Home System opens up a whole new market for the serviceman. It enables him to provide better TV and FM reception in any signal location.

For complete details contact your Jerrold distributor or write to Dept. PD 77

## JERROLD

**ELECTRONICS CORPORATION**  
The Jerrold Building, 15th & Lehigh, Philadelphia 32, Pa.

Jerrold Electronics Corp., Ltd., Toronto, Canada • Export Representative, CBS International, New York 22, New York

**LOOK TO JERROLD FOR AIDS TO BETTER TELEVIEWING**

## HOME SYSTEM COMPONENTS

### HOME AMP... MODEL HSA-46



The 1st printed Circuit TV-FM amplifier. Greatly improves weak signals; flat response across entire (VHF) TV-FM band. Only 2 tubes, designed for 24-hr. operation, consumes only 18 watts. Color compatible, UL approved.

**\$4995** LIST

### ◀ FLUSH OUTLET... MODEL HS-140

**\$275** LIST



### SURFACE OUTLET... MODEL HS-135 ▶

**\$195** LIST

The outlets supply clear strong signals without interference between sets. Each includes Perma-Grip plug for TV or FM. Color: Ivory.



**No Trimming of Wire Necessary...No Soldering! Quick Screwdriver Installation.**



**ALSO AVAILABLE in ready-to-install kit form**

**Home System Kit Model HSK-300**

Contains everything (except antenna) for complete 5 outlet system—including Twin-Lead.

**\$6775** LIST

For Installation in New Homes and Existing Homes.



# 3 Million Transistor Portables

*Mean Big Battery Business  
and Bigger Dealer Profits*

That's a lot of transistor portables that are going to be needing batteries this year . . . nearly three times as many as a year ago, and the figure is still growing.

For this skyrocketing new market, Mallory offers a complete line of transistor and portable radio batteries.

Mercury batteries, pioneered by Mallory, last longer, give steadier volume than ordinary batteries. Mallory Zinc-Carbon batteries are dependable and economical—meet all the requirements of today's modern portable radio sets, and flashlights as well.



In Canada, Mallory  
Battery Company of  
Canada Limited,  
Toronto 4, Ontario

• Capacitors • Vibrators • Resistors • Controls • Switches • Filters  
• Rectifiers • Power Supplies • Mercury and Zinc-Carbon Batteries

or the cabinet comes off of the chassis. Take two minutes to read the disassembly instructions! This can eliminate that 20- to 30-minute session of cussing and sweating the thing apart.

After you get the set apart, you find that there is no B+ voltage but don't see a fuse; consult the component placement chart and see if a fuse or fusible resistor is used. There's no need to spend 10 or 15 minutes trying to physically trace the circuit; if there is a fuse, it will be shown on the chart.

All right, you've found the open fuse and have restored B+ to normal. Now you notice that the horizontal hold control must be set to one end of its range to synchronize the picture. The service adjustment section of the literature outlines an exact procedure for correctly balancing the horizontal oscillator frequency and hold control range. Following this procedure and making the necessary adjustments takes but a minute or two and results in a callback-free repair job.

Other helpful information provides voltage readings and waveforms shown at key points on the schematic. Such important things as service adjustment procedures, alignment instructions, resistance readings, tube and parts layout guide, dial-cord stringing guide, and field service hints are also included within the confines of complete service data. For your own benefit, you should make a habit of using this information.

Are printed wiring boards a nemesis to you? Do you have trouble tracing the circuit and locating the components associated with a stage? If you dislike working on printed boards, or if you find it takes longer to service circuits using printed boards, you'll be pleased with the new *CircuiTrace* feature included in PHOTOFAC T Folders starting with Set 414. *CircuiTrace*, as shown in Fig. 1, keys the junctions between components to corresponding points on the foil side of the board. If you want to check the value of a resistor, test a coil for continuity, measure voltages, observe waveforms or make other analyses, locating the proper test points on the *CircuiTrace* diagram is a simple matter. Using this feature eliminates the need for



tracing the foil conductors, and thus speeds printed-board servicing time to the point where it is on a par with time consumed in repairing conventional circuits.

**You Can't Use It If It's Gone**

A tool as valuable as your service literature should be guarded zealously. Above all, keep it clean and return it to its proper place in the file when the job has been completed. This will guarantee its availability when it is again needed. This brings up another point—the material won't be available if you've never obtained it. Sure, service data costs money (what doesn't), but have you considered what it costs you in lost time when the necessary data is not at hand, and work is stopped until you get it or you try to make the repair without it? Conservatively, a busy shop will lose from 15 to 25 man hours a week running out after literature or trying to work without it. Converted to money, this represents \$75 to \$125 a week if you charge \$5 per hour for technical services. Quicker Servicing means more profit—think about it!

**More About Printed Board Servicing**

Aside from the difficulty of tracing printed boards, there is the problem of removing components such as PC units, IF transformers, tube sockets, filter capacitors, and potentiometers which have a number of connections to the board. This problem is not due to the extreme hardness of the solder used nor to the inaccessibility of soldered joints, but to the necessity for laboriously heating and brushing solder away from



Fig. 2. Ungar De-Soldering Kit is designed for multiple solder connections.

... another  
**MALLORY**  
service-engineered  
product

# Mallory "Sta-Loc" Controls Let You Replace the Line Switch by Itself

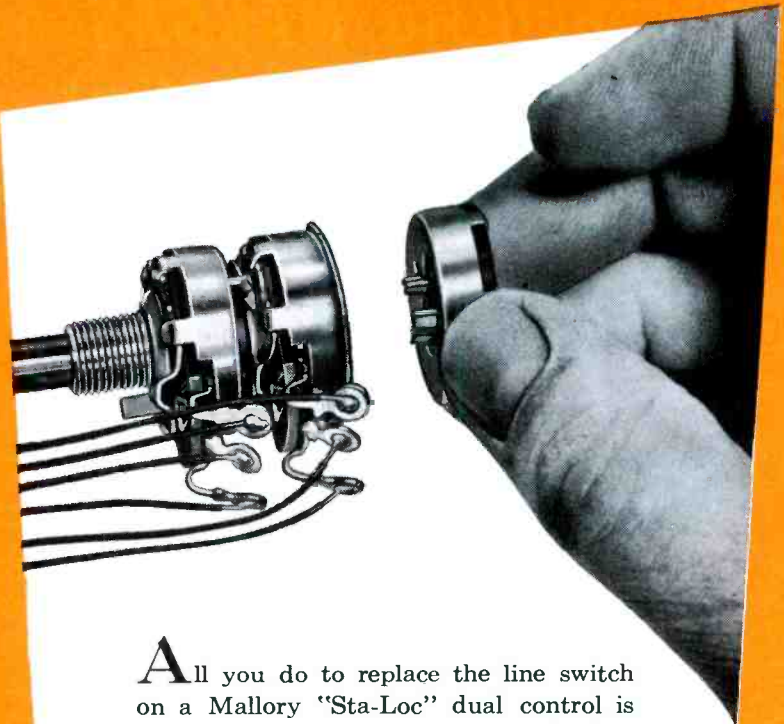

All you do to replace the line switch on a Mallory "Sta-Loc" dual control is twist off the locking ring, remove the line switch element and put on a new one. No need to replace or rewire the control sections. That's why replacing with "Sta-Loc" controls is your best insurance against lost repair time. Mallory line switches, with exclusive "floating ring" contacts, give longer life too. Your Mallory distributor can supply the exact "Sta-Loc" dual concentric control you need. See him today.

P. R. MALLORY & CO. Inc.  
**MALLORY**  
P. R. MALLORY & CO. Inc., INDIANAPOLIS 6, INDIANA



- Capacitors
- Vibrators
- Resistors
- Power Supplies
- Mercury and Zinc-Carbon Batteries
- Controls
- Switches
- Filters
- Rectifiers

A must  
for TV and  
radio  
service  
technicians



*with built-in MAGNASTAT  
temperature control*

... automatically maintains correct soldering temperature

	<p><b>MODEL TC-40</b>—40 watts. Controlled lower temperature for printed circuits, etc.</p> <p><b>\$8 00</b> list price</p>
	<p><b>MODEL TC-60</b>—60 watts. Controlled temperature for light to medium electrical soldering.</p> <p><b>\$9 00</b> list price</p>
	<p><b>MODEL TC-120</b>—120 watts. Controlled temperature for me- dium to heavy electrical soldering.</p> <p><b>\$10 50</b> list price</p>

Here's another "first" from Weller, long time leader in the soldering field. New soldering irons with *built-in MAGNASTAT temperature control* for more reliable soldered connections. Never any overheating. Proper soldering temperature automatically remains constant. Plus these other exclusive features:

- Saves current when idling
- Reaches full heat quickly
- Approximately 1/2 the weight of uncontrolled irons
- Delicate balance—cool handle
- All structural parts are stainless steel
- Cord plugs into handle
- Guaranteed against defects in material and workmanship

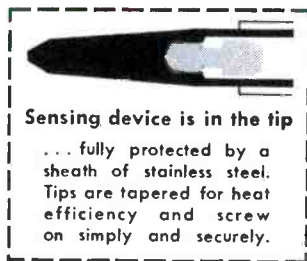

**Order NOW from your Electronic Parts Distributor  
or write direct for catalog bulletin**

**WELLER ELECTRIC CORP.** 601 Stone's Crossing Rd.  
Easton, Pa.

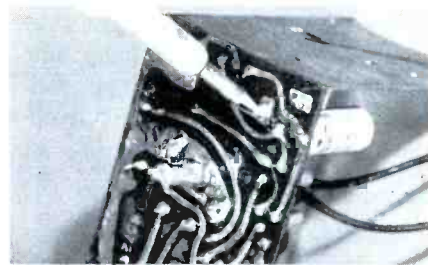

Fig. 3. Slotted tiplet is used to straighten and unsolder lug simultaneously.

each joint until the multiple connections are freed. Then too, lugs which are bent over and soldered to the board must be unsoldered and straightened before the component can be removed.

To eliminate these problems is to further simplify the task of printed board servicing. The De-Soldering Kit just introduced by Ungar Electric Tools, Inc. (shown in Fig. 2) is a big step in the right direction. It consists of a soldering pencil with a 47.5-watt heating element plus slotted, bar and circular tiplets packed in a cork-padded case.

Like any other soldering or de-soldering instrument, these tiplets can perform to best advantage only when properly tinned. Even though 60/40 solder is employed on most printed boards (it melts at about 380°F), it is suggested that you tin the tiplets with 40/60 or 50/50 solder. Mixtures with higher lead content have a higher melting point and will not vaporize as quickly. Tin each tiplet as soon as it heats enough to melt solder to prevent surface oxidation. If you don't, the oxide coating will have to be removed before the tiplet can be tinned.

**Applications**

The slotted tiplet is designed to melt the solder and straighten bent lugs simultaneously as shown in Fig.

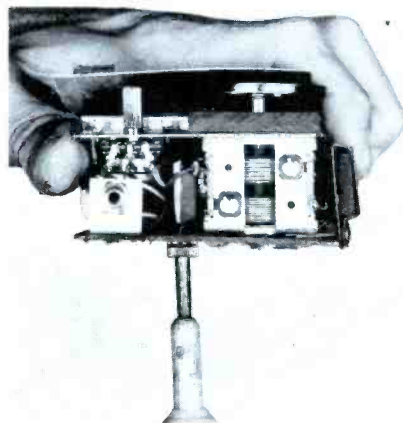

Fig. 4. Holding wiring side down causes melted solder to accumulate on tiplet.



3. It may also be used to resolder connections by filling the slot with 60/40 solder and then touching it to the component lead. Solder will flow out of the slot to form the joint. The bar triplet is intended for desoldering items having several connections in a row. The round triplets are for removing tube sockets, IF transformers and other components with several connections clustered in a small circular area.

All of the triplets are designed to attract solder from the joints and to radiate a minimum amount of heat from the sides. If you hold the wiring side of the board down when removing a component (Fig. 4), the melted solder will accumulate on the triplet and away from the board, thereby preventing board or component damage. A word of caution here: don't wave the triplet around; molten solder collected during the desoldering process could drop on your hand and result in a burn.

#### Extension Cord for "Cheaters"

A friend of ours made a suggestion the other day that we thought was very good. He pointed out that "cheater" cords are continually being left on the job, or are not long enough to reach the nearest outlet. His suggestion was to make a jumper that could be used to complete the connection from the receiver interlock to the back cover when removed using a cube tap along the line to provide power for accessories.

Considering what a help such an item would be on home calls, we couldn't help wondering why some manufacturer hadn't made one commercially available. Yep — you guessed it — someone does. As shown in Fig. 5, R-Columbia Products Co., Highwood, Ill., makes a "cheater" cord, Catalog No. AB-6, outfitted with both standard and polarized (for Zenith sets) interlock connections which can be used in conjunction with their Cheater Cubes A and B. ▲

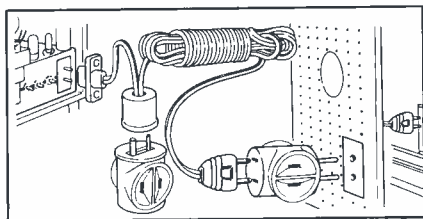
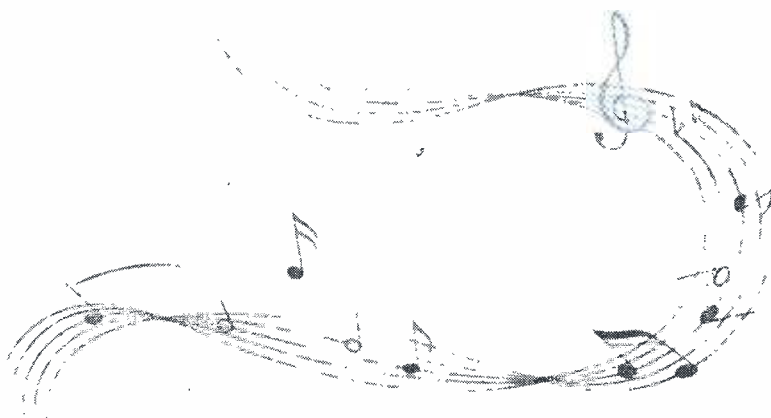

Fig. 5. R-Columbia Cheater Cubes and cord has both interlocks plus 5 outlets.

## Note the improvement



## You can easily make music sound richer with Centralab Compentrol®

Put Centralab Compentrol in your customers' radios and TV sets, and *presto!* Sound satisfaction! That's because this remarkable control with built-in compensating circuits provides perfect tonal balance of the highs and the lows—and does it automatically at any volume level. Unlike ordinary controls, Compentrol brings out the full richness of the sound . . . brings hi-fi into any living room.

Compentrol is easy to install in any radio, TV, or hi-fi set. You merely replace the existing control . . . no circuit changes required.

**FREE:** A booklet describing in detail how the Compentrol works and how easy it is to install. Write directly to Centralab for your copy.



**6 MODELS AVAILABLE**—Replace standard volume controls without rebuilding. Fit all hi-fi's, record players, radios, TV, pre-amplifiers, amplifiers, tuners, and tape recorders.

**Centralab** A DIVISION OF GLOBE-UNION INC.  
942J EAST KEEFE AVENUE MILWAUKEE 1, WISCONSIN  
IN CANADA: 804 MT. PLEASANT ROAD • TORONTO, ONTARIO

B-5839

# TIPS

# for TECHS

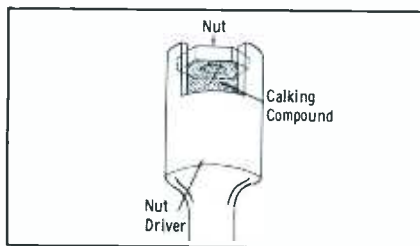

## Easy Nut Starting

You will find that it is much easier to start nuts in hard-to-reach places if you stuff a wad of non-hardening calking compound down into the nut driver's socket as shown. A nut usually tends to slide down into the socket, but this can't possibly happen with the stop in its way. What's more, the nut won't slide out when the driver is held handle up.

## "Oven" Exposes Thermal Intermittents

Many of the intermittent troubles encountered in radio-TV apparatus are thermal in nature and become evident only after the tubes and other components have had sufficient time to reach their operating temperature. Troubles of this type may not appear after the chassis has been removed from its cabinet because of the added ventilation. To speed warm-up and aid in exposing the possible cause of such troubles, line a large cardboard box with

household aluminum foil (tape or glue it in place), and place it down over the chassis with the equipment turned on. A weight should be placed on top of the "oven" to assure that heat will not escape from the crack around the bottom of the chassis. The foil-insulated "oven" will fill with heat more quickly than just an ordinary uninsulated box, and be of considerable help in bringing the trouble out of hiding.

## Nailpolish "Dopes" Corona

When there's no anti-corona dope available to spray on parts, to cure arcing in a high-voltage circuit, nailpolish makes a good substitute. This is a good hint to remember, for if you should suddenly find yourself out of anti-corona dope while servicing a set in the customer's home, some borrowed nailpolish can quickly cure the trouble and save you time.

## Carry Beeswax in Your Kit

If you add a bar of beeswax to your tool kit, you'll find it will help you solve many minor radio-TV service problems. You can use it as a sealer for overheated paper capacitors and choke coils (apply with a warm iron), or to touch-up scratches and nicks on cabinets. It also makes a good non-fluid lubricant for record changer drawer slides.



## Solder Spool Has Iron Cleaner

Need some quick and easy way to remove scale and accumulated solder from your gun or iron tip? Stuff one of those brass pot cleaners or wire dishcloths into the center of your solder spool as shown. This is one iron cleaner that can't be misplaced, for it goes wherever your spool of solder goes. You can transfer it quickly to the next spool once the present one is exhausted.

## Liquid Rubber Servicing Aid

A tube of plastic rubber is mighty handy for certain repairs. For example, the liquid rubber can be used to mend torn speaker cones (it remains flexible when dry) and as liquid insulation for bare wires. With it you can make your own "any-size" rubber feed-through insulators for chassis or cabinet.



## Solder Stops Drill

When you find yourself in need of some sort of device to arrest the travel of your drill bit, simply take a length of wire solder and wrap it around the bit as shown. Clip the solder off at the depth you want to drill. When the drill stop is no longer needed, slip it off the bit, toss it into your tool box, and use it later for its original purpose.



## Non-Tangle Cheater Storage

To prevent your "cheater" cord from becoming entangled with other tools when carried in the tool box, keep it stored in a plastic bowl cover as shown. This will save you considerable time and temper when servicing sets in the home — in addition to improving the neatness of your tool kit in the eyes of your customers.

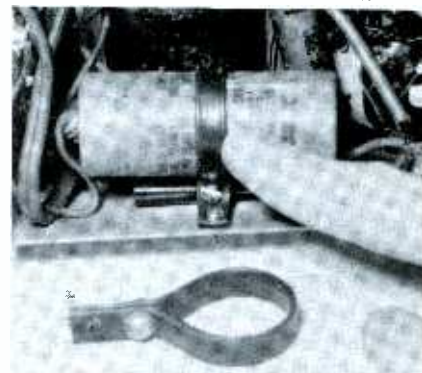

## Electrolytic Mounting Brackets

If you ever find yourself temporarily out of electrolytic mounting brackets, lengths of TV ribbon lead-in can be used to improvise useful substitutes. Cut the lead to a length which will fit around the component snugly, and allow about a one-inch overlap for mounting. Punch or drill two holes in the overlap to accept mounting screws.



**OLD-STYLE  
PARALLEL-CONNECTED  
HEATERS**

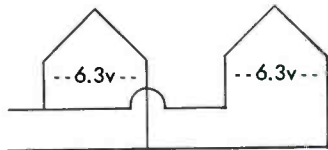

... used small wire which was easily bent, contributing to heater-cathode short-circuits.



**NEW G-E  
SERIES-CONNECTED  
HEATERS**

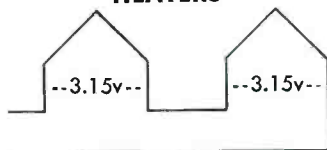

... use wire twice as thick, that holds its shape. Short-circuits have been reduced.

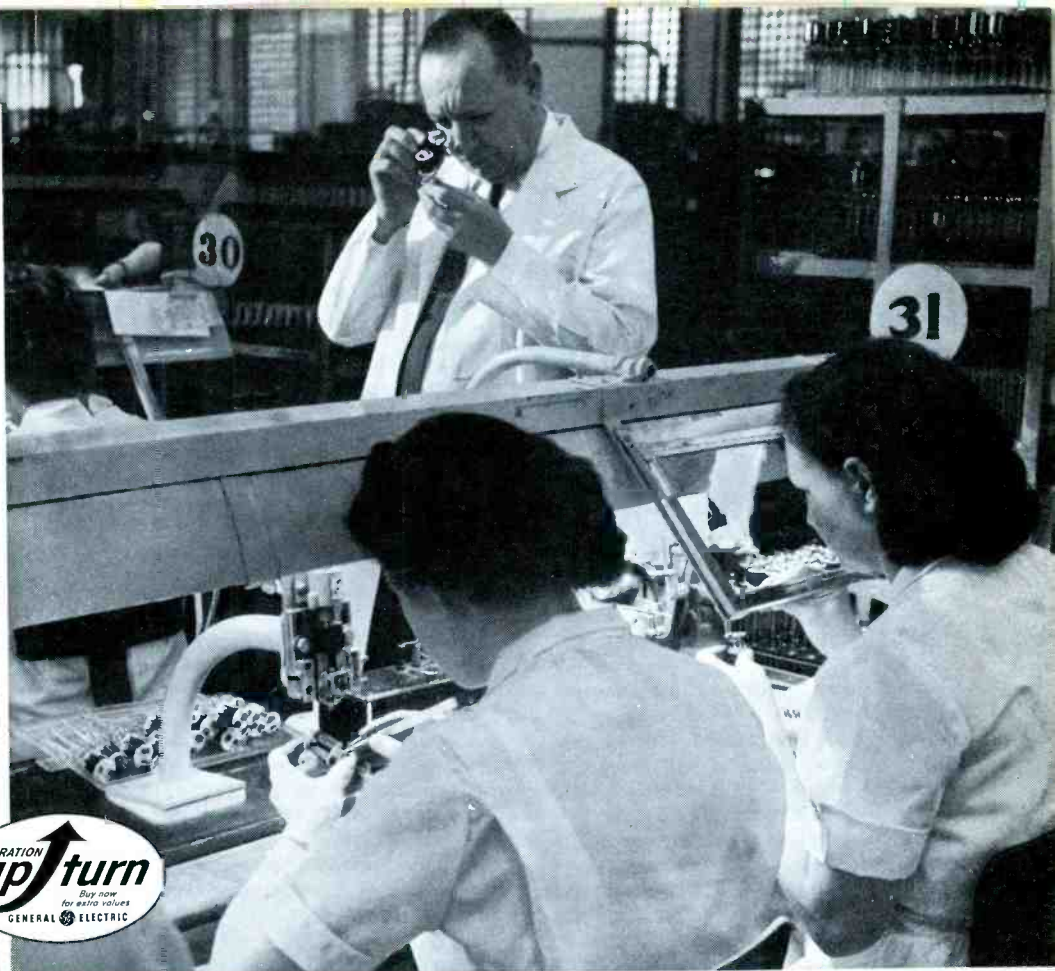

**ABOVE: LINT AND DUST ARE BANNED** during "Snow White" assembly of General Electric receiving tubes, in order to reduce the possibility of short-circuits. G-E workers and supervisors wear lint-free garments; air is filtered and conditioned; floors are kept immaculately clean.

**LEFT: NEW HEATER DESIGN CUTS SHORTS** . . . heater to cathode . . . in 6BQ7-A and 6BZ7 cascade RF amplifiers. Here is an example of how G.E. constantly improves Service-Designed Tubes. New G-E series-connected heaters use heavy wire that resists bending, crimping, arc-overs.

# Improved tube design—superior manufacture—mean fewer shorts with G-E Service-Designed Tubes!

GENERAL ELECTRIC Service-Designed Tubes *stay installed*. Short-circuit inoperatives are kept at a minimum. You save time by making fewer callbacks. You increase your service reputation with repair-work that seldom has to be done over—in a few days, even a few hours—because a tube has shorted internally . . . perhaps burning out other components of the TV circuit.

In design, as with the 6BQ7-A and 6BZ7 heaters—in manufacture, where every advanced technique is called on to remove lint and dust—General Electric gives you, as a television technician, tubes you can install with complete confidence.

Yet Service-Designed types cost no more! Your G-E tube distributor has these high-quality tubes. Phone him! *Distributor Sales, Electronic Components Division, General Electric Company, Owensboro, Ky.*

**G-E SERVICE-DESIGNED TUBES INCLUDE:**

1B3-GT	6AF4	6BG6-GA	6BX7-GT	6SN7-GTB
1J3	6AF4-A	6BK7-B	6BZ7	12SN7-GTA
1X2-A/B	6AL5	6BQ6-GA/6CU6	6CB6/A	25BQ6-GA/25CU6
5U4-GB	6AV5-GA	6BQ6-GTB	6CD6-GA	25BQ6-GTB
5Y3-GT	6AX4-GT	6BQ7-A	6J6	25CD6-GB

*Progress Is Our Most Important Product*

**GENERAL ELECTRIC**

11-11-125

# THE TROUBLESHOOTER

ANSWERS YOUR SERVICE PROBLEMS

## Christmas-Tree Effect

I have horizontal trouble in a Packard-Bell Model 2200. By disconnecting C52 and turning the horizontal frequency slug down almost as far as it will go, I can lock in the picture—but it still has a little pull in it. When I reconnect C52, the picture goes completely out of sync. The number of slanting lines decreases as I turn the frequency slug back toward the normal position, but just before the point where the picture would be expected to sync in, the raster draws in from both sides and the flyback transformer develops a high-pitched whistle. It looks like "Christmas-tree" effect.

I have tried a new flyback and width control, and have changed R65, R66, R68, C53, C59, R69, and R71. I have checked everything else I think could cause this, but must have slipped somewhere.

ROBERT J. GRANT

Culver City, Calif.

*The horizontal oscillator is probably defective in such a way as to make it run too fast. This would cause the AFC circuit to lose control of oscillator frequency, thus resulting in the "Christmas-tree" effect you described. To restore sync, you had to change the resonant frequency of the ringing circuit in the oscillator and also cause an artificial negative shift in AFC voltage. You wisely*

*decided not to leave the circuit in this altered condition, since the AFC circuit would not maintain stable operation with C52 disconnected.*

*I assume you have tried at least two different replacements for the 6SN7 in the oscillator circuit, as well as a new 6AL5 in the AFC. One component very likely to need replacement is C58. Also try a new horizontal frequency coil and a new C57. If none of these things help, substitute for C54.*

*It's possible that the AFC voltage is tending to run too positive as a consequence of some defect ahead of the oscillator, but I think this is less likely than oscillator trouble. However, if all else fails, try substituting the remaining components in the AFC circuit.*

## Selenium AFC Diodes

What are some symptoms of troubles that might occur in dual-selenium AFC diodes, such as the 93A5-2 used in Admiral TV receivers, or the common-cathode units employed in General Electric receivers?

MICHAEL J. SHIVEY, JR.

Cleveland, Ohio

*The symptoms are about the same as those caused by defects in vacuum-tube AFC diodes; that is, the exact nature of the symptom depends a lot on the type and degree of trouble. For example,*

*a loss of sync that could not be corrected with the hold control might stem from an unbalanced condition in the AFC circuit. This, in turn, might be traced to one open diode in the pair of selenium units.*

*Even when both diodes are able to conduct, their forward or reverse resistances may be unbalanced just enough so that the picture will drop out of horizontal sync each time there is an interruption in the incoming signal. (This often happens when the transmitting station switches from one camera to another.) Sync can usually be restored with the hold control, but it is usually lost again the next time the scene changes.*

*Defective selenium diodes can also cause other troubles such as bending or side-to-side shifting of the picture. Almost any kind of horizontal sync trouble would be reason enough to try substituting a new pair of AFC diodes as a general troubleshooting measure.*

## Triple Image

On a 16" Sparton, I get three images instead of one. I've checked the tubes and replaced the resistors and capacitors in the horizontal circuit, but this hasn't done any good.

JOSEPH C. POUSAK

Wyandotte, Mich.

*If you have three separate images side by side, the horizontal oscillator is running at  $\frac{1}{3}$  its correct frequency. The trouble might not be in the oscillator itself, though; it could be in the AFC circuit or some other stage.*

*You can get some valuable information from grounding the grid of the first stage in the horizontal multivibrator. This will prevent the AFC circuit from having any influence on horizontal frequency, and the oscillator will then be free-running. You probably won't be able to get a steady picture, but you may be able to pull in a normal-looking single image for a brief moment by manipulating the horizontal frequency slug. Actually, all you need to know is whether or not the triple-picture effect has disappeared. If it has not, the trouble must be in the oscillator or a later stage. Try replacing not only resistors and capacitors, but also the horizontal frequency coil.*

*In case the picture was restored nearly to normal when you grounded the grid, the oscillator can be assumed to be operating properly. Then it is necessary to find out why the AFC stage is "misleading" the oscillator. The trouble might be due to a component defect in the AFC circuit or to a faulty sync or feedback signal arriving at the AFC input.*

## Garbled Sound

I am having some trouble with a Motorola Chassis TS533Y. Since I replaced electrolytic capacitor C2, the sound has been distorted. The plate and screen voltages of the audio output tube, which are supposed to be 105 and 115 volts (measured from the 145-volt line), are only 30 volts as measured from this line. I have substituted all other capaci-

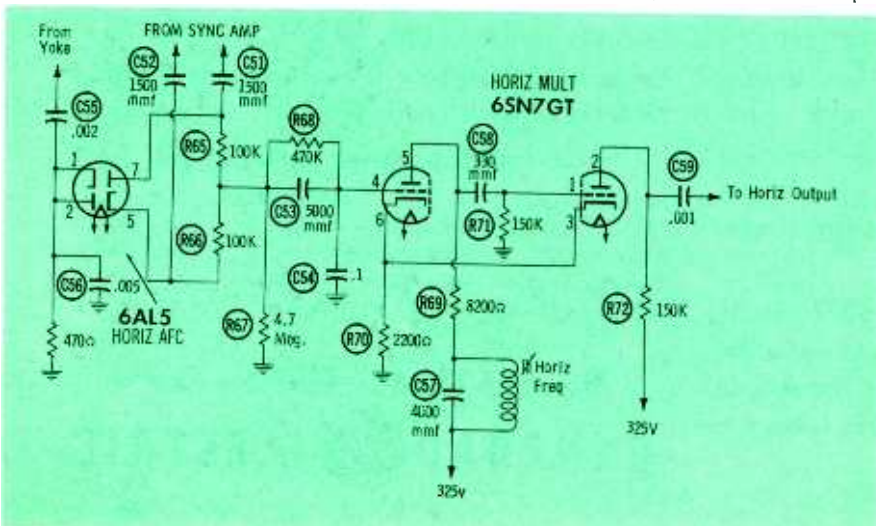



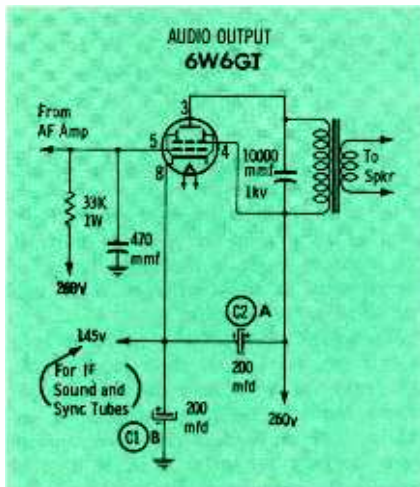

tors in the circuit, but have had no luck in finding the trouble.

JOHN WM. OLIVER, SR.

Portsmouth, Va.

The audio output tube in this set acts as part of a voltage divider across the B+ power supply, and any defect involving this tube affects the voltage on the low B+ line. (Nominal value of this voltage, as shown on the schematic, is 145 volts with respect to ground.) Thus, the value of the low-B+ voltage in your set should serve as a clue to the nature of your trouble.

Let's say that this voltage is on the low side. Since the total supply voltage of 260 volts is more or less fixed, this suggests that there is a greater voltage drop than normal across the audio output tube and its plate load. We already know that the drop across the tube itself is extremely low—less than a third of the normal value. Therefore, we can expect an abnormally great voltage drop across the plate-load circuit, indicating an increase in the resistance of this circuit.

With screen and plate voltages being so nearly equal, about the only thing that could cause this is a cold-solder joint at the connection between C2A and the wire leading to the audio output plate circuit.

In case this doesn't provide a solution, let's take another approach to the problem and assume that you have more than 145 volts on the low-B+ line. This condition would imply a lowering of resistance between the 145-volt and 260-volt lines, such as would occur if the audio output tube were to conduct too heavily. Since the cathode-to-plate voltage has dropped down to only 30 volts, conduction through the tube may have become extremely heavy. In order to reduce the internal resistance of the tube enough to cause such heavy conduction, however, you would almost have to have severe gassiness or an internal short.

### Too Much AGC

An RCA Victor Chassis KCS92D has no picture unless the AGC control is advanced to within 20 degrees of its fully-clockwise position. The resistance between pins 2 and 3 of the keying tube, which should be 30K ohms when the AGC pot is centered, is only 20K. I have replaced

R47 and R46. What could be causing this incorrect reading?

ED HEGAR

Pocomoke City, Md.

There are two parallel DC paths between the grid and cathode of the AGC tube. Besides the obvious one through R47, there is another through the plate circuit of the video amplifier and the 150-volt B+ line. Remember that the AGC tube must be directly coupled to the video amplifier plate so that the DC level at the latter point can serve as an input "signal" for the AGC circuit. Resistance values in this network are chosen to furnish the desired operating voltages to the tube elements, as well as to provide isolation between the video and AGC circuits.

The grid-to-cathode resistance of the AGC tube in your set might be too low because of shorted components in the video amplifier plate circuit, or there might be leakage from pin 2 to pin 3 across the AGC tube socket.

The defect in this set is lowering the bias on the AGC tube and forcing it to conduct too heavily. This results in too much AGC voltage, which blocks the RF and IF amplifiers and kills the video signal. The bias is not completely dependent on the video amplifier plate voltage, but can be regulated to some extent by adjusting the AGC control. Note that the arm of this control picks off a variable positive DC voltage from the 275-volt line. When the control is in its maximum clockwise position, no positive voltage is furnished and the AGC tube is biased most heavily. In your case, the maximum obtainable value of bias appears to be scarcely enough to bring the RF-IF stages out of cutoff.

### Pulling

A Meteor (Sears, Roebuck) Model 7146 had a bad case of horizontal pulling. The effect was somewhat the same as a 60-cps bend in the picture, but there was no brightness modulation. At full contrast, the picture was fairly steady but too dark for good viewing. The tearing effect became worse as the contrast setting was reduced.

I substituted all tubes and checked the picture tube in the home, but with no luck; so I took the set to the shop. On the bench, I checked various voltages from the RF amplifier through the sync separator. All were apparently within tolerance.

Then I took my scope and traced the signal through the sync section. The waveforms showed clearly what was happening. At the grid of the sync amplifier, the sync pulses looked normal when the contrast was all the way up. Backing off this control caused video to appear in the waveform. By the time the minimum setting was reached, the pulses were completely destroyed by video. I bridged a .005-mfd capacitor from the sync take-off point in the video amplifier circuit to the grid of the sync separator (i.e., across the "PAC" module) and noticed a definite improvement in the sync pulses. A new module unit cured the trouble. The

old one was found to have 30 megohms of leakage across the sync-input coupling capacitor.

W. H. CLARKSON

Kansas City, Mo.

This is a good example of how a technician can get results from a logical troubleshooting approach. This job undoubtedly took plenty of time as things were—but imagine how long it could have taken without the help of the scope.

### Co-Channel Interference

We are having severe problems with two stations on the same channel wanting to come in at the same time. Low-band channels are the worst. If we try to get Channel 3 from Harrisonburg, Va., other stations on that channel in Norfolk, Va., or Charlotte, N. C., or both, try to come in. The Channel 6 stations in Richmond, Va., and Bluefield, W. Va., act the same way.

I have tried different antennas in several different locations with no success. The interference is worst in cloudy weather. Can anything be done to remedy this situation?

ROBERT L. ARBOGAST

Monterey, Va.

Researchers have found, much to their surprise, that the presence of a mountain range between a receiver and a distant transmitter will often improve reception of the faraway station instead of blocking it off. I see by the map that you have a "perfect" setup for this effect. Trouble is, it wasn't taken into account when your local TV allocations were established—so you're nearly out of luck.

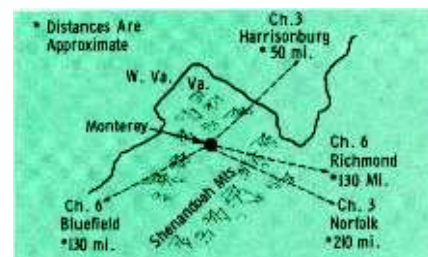

But don't give up until you have tried every method of attack you can imagine. What with multipath reception, shadow areas, and the strange effect just described, TV reception in mountain areas is extremely unpredictable. You might be able to pick up an unusually strong reflected signal from some odd angle. Keep on "fishing" for a signal, using a highly-directional antenna array which also has a high front-to-back ratio and trying it out in every possible orientation. Tilting the whole array, with the boom slanted at some angle up or down from horizontal, has even been known to help. Moving the whole antenna to a new location might eventually provide the final solution.

### No High Voltage

A Tele-King Model K74 does not have high voltage after the first few minutes of operation. I have substituted the horizontal output transformer and yoke. Plate voltages on the 6SN7 horizontal oscillator are supposed to be 33 volts on

# CDR ROTORS

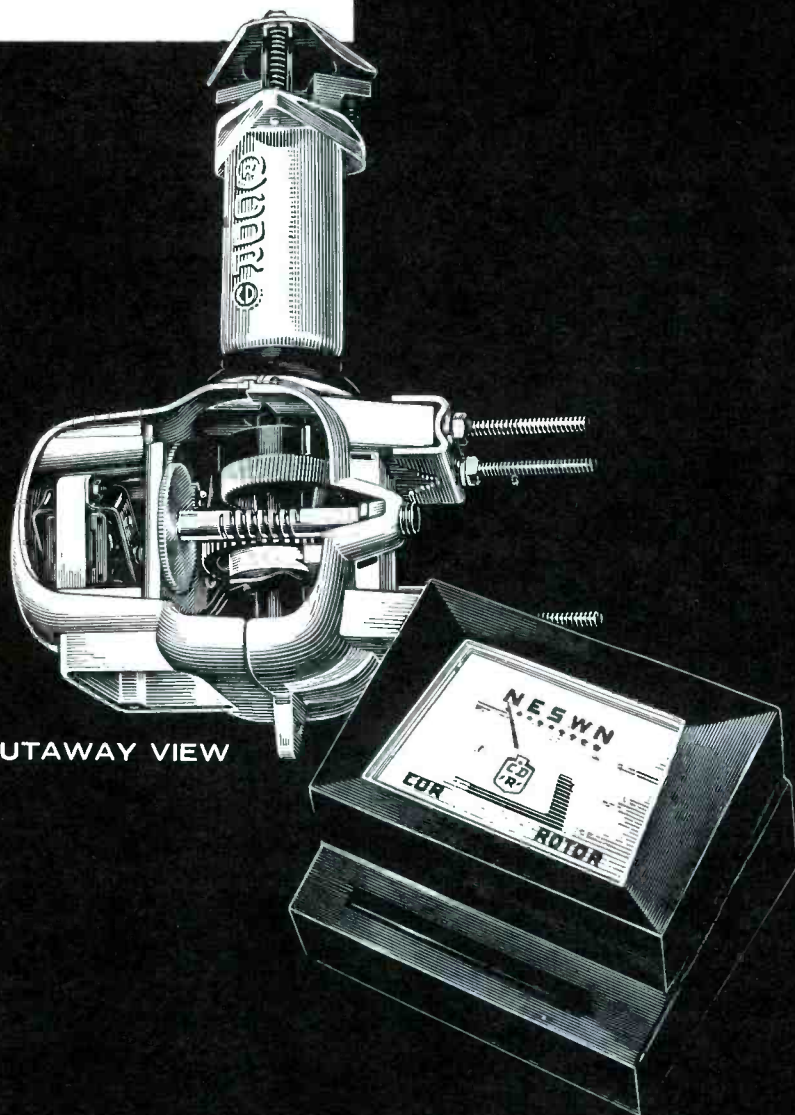

CUTAWAY VIEW

## All new features

Completely designed from the ground up, CDR Model TR-15 and TR-16 Rotors have features never before available in the popular price range. Check these refinements and you'll see why: Quick mounting mast collet... speedy installation (no loose parts to assemble)... self-centering sawtooth clamps take masts up to 1½" O.D.... instant locking prevents drift... mechanical brake releases magnetically... instantly reversible... makes complete revolution in 45 seconds... meets JAN salt water test... great strength thrust bearing support... low weight... completely weather-sealed... fits standard towers... streamlined to reduce wind resistance... mahogany or blonde finish control box. Get full details today from your local CDR distributor.

CORNELL-DUBILIER ELECTRIC CORP.  
South Plainfield, New Jersey

THE RADIART CORPORATION  
Indianapolis, Indiana



# CDR

## Antenna Rotors

Old Hands at Dependability

the first section and 135 volts on the second section, but I get just the reverse after the high voltage disappears.

PEMBERTON'S TV & RADIO

Flora, Ill.

*The 6SN7 is evidently not oscillating. Check for presence of a drive waveform at the grid of the horizontal output tube. Lack of a signal at this point means that you need to make a thorough check of components in the oscillator stage and output-tube grid circuit.*

*Since both plates of the oscillator tube in this receiver obtain their supply voltage from the B+ boost line, you might expect that the oscillator would be unable to operate unless the boost circuit were working properly. Such is not the case; in the absence of boost, the oscillator plates still receive voltage from B+ by way of the damper tube. While the value of voltage thus obtained may not be enough to let the oscillator develop a perfectly normal output signal, you should be able to get enough to drive the output stage and build up boost voltage.*

### Excessive Output-Tube Current

I have a 21" Sparton Model 5298 in which too much current flows, causing the fuse to blow. After the warm-up period, the horizontal output tubes (two 6BQ6GT's in parallel) glow blue. A high-pitched squeal is heard in the high-voltage section, proving that the horizontal oscillator is operating. I read 10 volts between ground and the grid of one of the 6BQ6GT's. What could be causing the fuse to blow? I am enclosing a list of resistance readings from all sync, sweep, and high voltage tubes.

BAILEY SCHLOCKER

San Francisco, Calif.

*The fuse in this set is intended mainly to protect the horizontal output and high-voltage circuits; therefore, its failure indicates that excessive current is being drawn in this section of the receiver. The blue glow in the output tubes is further evidence of trouble in this area.*

*A grid bias of only 10 volts on the 6BQ6GT is not sufficient. You may have a defect in the grid circuit, or it is possible that the horizontal oscillator is not working normally. You can determine whether or not such troubles exist by checking the drive waveform at the output-tube grid. (This can probably be accomplished without blowing a fuse if you remove the output tubes from the set.) As in the case of the Tele-King receiver just described, you probably won't get an exactly normal waveform if there is horizontal-output trouble. Your Sparton is another of those sets in which the B+ boost circuit supplies plate voltage for the oscillator. You should see a reasonably familiar waveform, however. By the way, be sure to check the frequency of the oscillator signal. The fact that you can plainly hear a squealing noise suggests that the oscillator frequency may be much too low, and this is one condition that*



could account for insufficient bias on the output tubes.

### Testing Capacitors; Squegging

What procedure is recommended for checking leakage between sections of a multi-section electrolytic capacitor? I have been applying the leakage-test voltages of a capacitor checker between two sections of the capacitor under test. Is this a suitable, safe method?

"Squegging" or "Christmas-tree effect" is not treated fully in any of the technical literature that I have available. Further discussion of this trouble in PF REPORTER would certainly be a help.

C. S. DOYLE

Denver, Colo.

*The capacitor test you describe is actually a check for DC leakage between anodes, a condition which is not generally considered to be a serious problem outside of the fact that it involves cathode-to-anode leakage within the individual sections. A certain amount of inter-anode leakage normally occurs through the electrolyte, which is common to all sections of the capacitor. Your test is safe enough, but in order to learn anything valuable from it, you need to know how much leakage to expect in a good unit.*

*A more important problem in multi-section dry electrolytics is AC leakage, or the coupling of hum and ripple between capacitor sections through the common cathode impedance. The best check for this trouble is to substitute individual units for the various sections of the original capacitor.*

*For a clearer understanding of leakage in a multi-section dry electrolytic, consider its construction. These units are manufactured in somewhat the same way as paper tubular capacitors. A long strip of cathode foil is laid down and covered with a layer of absorbent material containing electrolyte, and then two to four separate sheets of anode material are placed over different areas of the cathode. Finally, the whole assembly is rolled up into a cylinder, as shown in the picture. AC isolation between sections largely depends on the relative positions of the different anodes.*

*"Squegging" is what occurs when the horizontal oscillator breaks in and out of oscillation at a regular rate. In a sense, this effect is related to motorboating. Symptoms are coarse, irregular horizontal lines on the CRT (i.e., "Christmas-tree" effect) and a periodic squeaking noise that is mechanically produced in the flyback. While squegging can be caused by faulty AFC operation and various other troubles, it is usually due to a defect in the horizontal oscillator itself.*

#### CORRECTION NOTICE

Errors in the figures appear on Pages 40, 41, and 44 of this issue. Figures 5 (Pg. 40) and 6 (Pg. 41) should be on Pg. 44 as Figs. 8 and 9, and vice versa, to correspond with the caption shown.

# TOBE

## America's Fastest-Growing Service Capacitor Line...



### TOBE MYLAR\* MOLDED TUBULAR CAPACITORS

- Molded of DuPont Mylar, one of the finest insulation materials ever developed.
- Thermoset Case Construction secures leads and sections firmly to withstand extremes of handling, vibration, shock and soldering temperatures.
- High Insulation Resistance: Average megohm values per unit 10,000 at 25°C. Small capacitance variation with thermal change.
- Temperature Operating Range: -55° to +130°C.
- Moisture Resistant: Exceeds JAN-C-91 requirements.
- Non-Inductive: Extended foil construction insures low resistance connections and low RF impedance.



DESIGNED FOR SERVICE DEALERS

NEW TOBE MYLAR\* CAPACITOR KIT

FREE KIT CONTAINS  
80 CAPACITORS

ONLY

**\$15<sup>84</sup>**

Today, order  
your Tobe Mylar  
Kit from your  
Tobe Distributor

Compact, clear-plastic dispenser contains an assortment of 80 Tobe Mylar capacitors in the most popular sizes, ratings and quantities for quick, efficient servicing. Covers over 60 different ratings at 200, 400 and 600 working volts and from .0001 to 1.00 mfd. Dealer pays only for the Tobe Mylar capacitors, kit is free.

**TOBE**  
**RADIART**  
CAPACITORS

\*DuPont trademark

[www.americanradiohistory.com](http://www.americanradiohistory.com)

TOBE DEUTSCHMANN CORPORATION, NORWOOD, MASSACHUSETTS



# NOTES on test equipment

by Les Deane

informative reports from the lab

## Probes For Troubleshooting

The units pictured in Fig. 1 are recent products of Doss Electronic Research, Inc., Kansas City, Mo. Especially designed for the radio and TV technician, these probe-styled instruments are identified as: (A) the *Hi-Leak Analyzer*, Model D-400; (B) the *Electrolytic Substitute*, Model D-600; and (C) the *Sync Master*, Model D-700.

Taking a look at these probes individually, let's start with the Model D-400. I made use of this instrument recently by checking leakage characteristics of a number of paper-tubular capacitors in a TV test chassis.

Following instructions, I plugged the AC cord of the probe into a bench outlet with the thumb switch on the unit in the discharge position. I then disconnected one side of the capacitor to be tested and, observing polarity, connected the probe across it. I next flipped the thumb switch to the test position and noted the neon indicator in the base of the

probe. One short flash of the bulb indicates a normal capacitor; however, repeated flashes or a steady glow will prove the unit to be either leaky or shorted. An open circuit will be indicated if the bulb fails to flash once when the probe switch is first thrown to its test position. This momentary glow tells you that the capacitor is accepting a charge. Although it may be difficult to see the flash on low-value units, the indication should be well pronounced on capacitors down to a value of .001 mfd. When the thumb switch is placed in the discharge position, the two test clips are effectively shorted and the unit under test is automatically discharged.

In my investigation, I found that the D-400 indicates leakage up to 500 megohms and that it is not only useful in checking leakage of capacitors having values up to 1 mfd, but that it is also handy for measuring heater-to-cathode leakage in tubes or primary-to-secondary leakage in IF transformers, flybacks, etc.

Since the *Hi-Leak Analyzer* tests

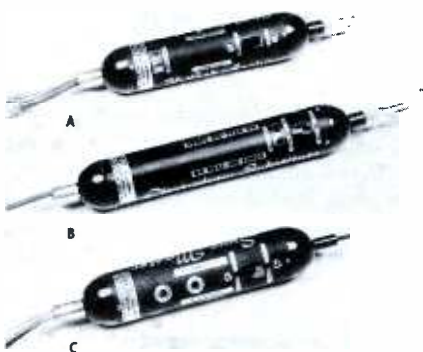

Fig. 1. Doss troubleshooting probes have removable tips, thumb switches.



Fig. 2. Self-gripping tips are featured on Model D-600 and D-700 probes.

components by the application of approximately 100 volts DC, one should exercise precautions against electrical shock or shorting the two test clips together. I also noticed that erroneous indications can result if the equipment containing the component under test is not completely isolated from the AC power line.

The *Electrolytic Substitute* (Fig. 1B) is especially designed to combat a problem of which many technicians are not fully aware. When substituting or bridging an electrolytic in a functioning circuit, a charging surge will often cause the suspected unit to heal itself, at least temporarily. With the defective electrolytic *healed*, nothing is really accomplished and the trouble symptom will most likely reappear after the set has been returned to its owner.

To overcome this situation, the D-600 incorporates a controlled-charge network within the substitution device itself. With one section of the dual-thumb switch in the RE-SET position, a resistance is connected in series with the internal electrolytic used, practically eliminating any charging surge.

To give you some idea of how the probe is used, here are the steps I followed to shunt-test a typical power supply filter in a TV chassis. With the set on, I attached the alligator clip on the end of the probe to chassis ground. In some receivers, this connection may go to B- or any point common to the negative terminal of the suspected electrolytic. Since the unit I intended to shunt was 140 mfd, I placed the *Hi-Lo* thumb switch in the *Hi* position. (In the *Lo* position, the instrument can be used to check electrolytics from 10 to 40 mfd, and in the *Hi* position, all units above 50 mfd.) Placing the other section of the thumb switch in its RESET position, I connected the red (+) lead to the positive terminal of the electrolytic. Something a little different in a self-gripping probe is used for this connection (see Fig. 2). The tip is composed of two metal parts; the larger, more rigid piece is notched, while the small wire-like piece provides spring-tension on the wire or terminal placed between the tip contacts.

After making these simple connections, I watched the neon indicator directly below the thumb switch,



a **VOM** ... plus a **VTVM** when you need it.  
**DOUBLE USE... HALF THE PRICE**  
**TRIPLETT MODEL 631**—In one year accepted as the  
 standard **COMBINATION VOM-VTVM**

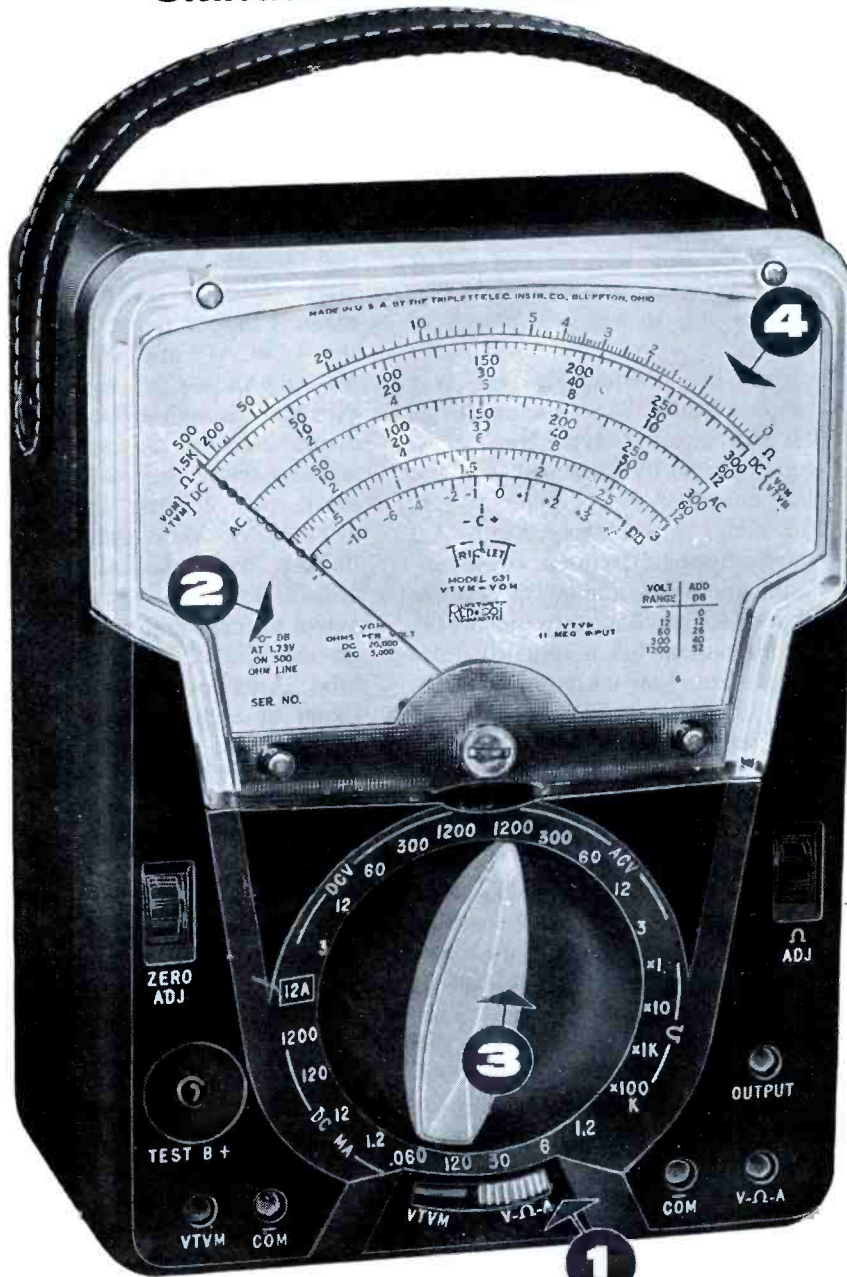

**Battery operated**

- 1** Just flip the switch.
- 2** Standard sensitivities as used in servicing manuals.
- 3** 34 ranges—with the famous Triplett single knob control.
- 4** Extra long scales—unobstructed visibility.

**\$64.50**

By using the Volt-Ohm-Mil-Ammeter for all general testing (90% of your testing) and the Vacuum Tube Voltmeter only when you need it, you have the advantage of a VTVM with extremely long battery life. Batteries are used only about one-tenth as much as in the ordinary battery-operated VTVM. Features: Ohms, 0-1500-15,000 (6.8-68 center scale. First division is 0.1 ohm.)

Megohms: 0-1.5-150 (6,800-680,000 ohms center scale.)  
 Galvanometer center mark "—0—" for discriminator alignment.  
 RF Probe permits measurements up to 250 MC. \$7.00 net extra.  
 Featured by leading electronic parts distributors everywhere.



**TRIPLETT ELECTRICAL INSTRUMENT COMPANY • 52 years of experience • BLUFFTON, OHIO**  
*Triplett design and development facilities are available for your special requirements for meters and test equipment.*



FROM TRIAD

## Solve majority of deflection problems

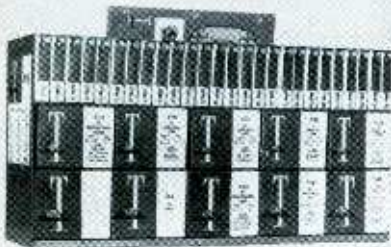

- 8 POPULAR YOKES
- 25 NETWORK KITS
- 2 ACCESSORIES
- PACKAGED IN ALL STEEL CABINET

Most of your deflection problems as well as your yoke stocking problems are solved with the new Triad Yoke Pack. With this equipment, the solutions to more than 4000 yoke testing and replacement problems will be available to the professional service man. The Yoke Pack comes attractively arranged in a handsome steel cabinet—and attractively priced, too. For further information on Triad's Yoke Pack as well as the latest

information on yoke servicing, request a copy of the Professional Television Man's Service Aid #3 from your distributor or write direct to:



**TRIAD TRANSFORMER CORPORATION**

4055 REDWOOD AVE. | 812 E. STATE STREET  
VENICE, CALIFORNIA | HUNTINGTON, INDIANA

A SUBSIDIARY OF LITTON INDUSTRIES

and in a few seconds the bulb reached full brilliance. This indicated that the substitute was fully charged, so I flipped the switch to TEST and noted set operation. The thing that impressed me most was the quick and easy manner in which I could switch the charged substitute in and out of the circuit.

I found that if you want to discharge the components in the probe, you can place the thumb switch in the RESET position and short the test lead to the probe tip. The discharge is slow enough so as not to cause a contact-damaging arc. The neon indicator will go out rather slowly; however, for charging or discharging this is merely a matter of seconds.

The *Sync Master*, Fig. 1C, is a low-impedance signal-tracing device that can be used with any oscilloscope. Primarily designed for the observation of video, sync, sweep, and audio waveforms, the D-700 offers additional frequency-compensation and step-attenuation features for your scope. Similar to the D-600, this instrument has a split- or dual-section thumb switch with each section containing two positions. The input selector half has a direct and a low capacity position, while the attenuation section can be placed either in a X10 or X100 voltage-divider position.

Using the *Sync Master* to view some TV waveforms, I followed instructions printed on the probe housing and matched the instrument to the scope I was going to use. Since oscilloscopes have various input impedance values, this matching procedure precisely calibrates the D-700 so as to reproduce accurate waveforms with a known voltage-

attenuation factor.

To calibrate the signal-attenuation properties of the probe, I attached its cable leads across the vertical-input terminals of the scope, fastened the separate ground lead to a TV chassis and turned the set on. Placing the selector switch in the DIRECT position, I attached the probe tip, which is the same type as shown in Fig. 2, to a tube-filament connection. Since the heaters were wired in parallel, this gave me a 60-cycle input signal with a peak-to-peak amplitude of approximately 18 volts. Setting up the scope so that the vertical deflection occupied ten large divisions on the calibration mask, I flipped the thumb switch to the LO-CAP and X10 positions. Varying the R-CAL screwdriver adjustment through a small hole in the probe housing, I made the input signal occupy one division on the mask, which now equalled only 1/10 the previous amplitude. Continuing with the matching procedure, I tuned the receiver to an active channel and placed the probe on the grid of the video amplifier tube. After obtaining a composite signal at a 30-cycle sweep rate, I trimmed the other screwdriver adjustment labeled C-CAL until the height of both vertical and horizontal sync pulses were equal. This last step effectively levels off the frequency response of the probe-scope combination and readies the instruments for general-purpose signal tracing.

When I used the *Sync Master* as a low-capacity probe, I found that it resulted in minimum loading of the circuit under test; also, that there was no need to change probes for different functions since its

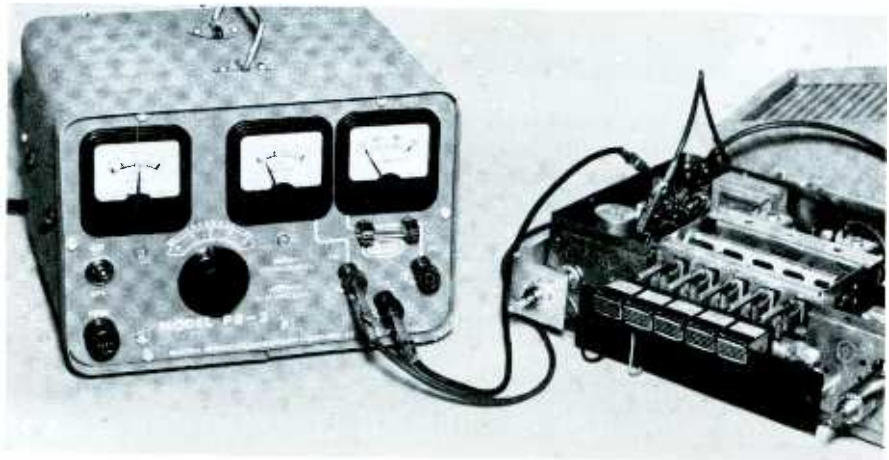

Fig. 3. New Electro Products supply is available in either wired or kit form.



thumb switch offers either direct or attenuated signals.

### DC Without Hum

The Model PS-2 Filtered DC Power Supply, shown in operation in Fig. 3, is manufactured by Electro Products Labs., Chicago. This compact bench instrument comes in either factory-wired or kit form, with the kit version identified as Model KPS-2. Designed primarily for powering transistorized auto radios, this well-filtered supply has many other applications where zero to 16 volts DC is required.

Specifications and features are:

1. Power Requirements—110/120 volts, 50/60 cps; power consumption variable with load; line fuse provided.
2. DC Output — adjustable from 0 to 16 volts in two current ranges of 0 to 5 amps and 0 to 75 ma, currents up to 10 amps available for short periods; AC ripple .15% with 75-ma load and 0.5% with 5-amp load.
3. Panel Features — DC voltmeter with 20-volt scale; DC ammeter with 10-amp scale; DC milliammeter with 75-ma scale; separate positive terminals for each current range and special panel fuse for low current circuit.
4. Size and Weight — 6" X 8½" X 8" over-all, 12½ lbs. net.

On examination of this piece of equipment, I found it very useful in operating and servicing all-transistor portables, hybrid sets, and both 6- and 12-volt auto radios without introducing hum. Good voltage regulation and adequate filtering is a must for an instrument of this type, especially when powering transistorized equipment. If a supply has high ripple content in its output, it usually interferes with the signal and can even permanently damage circuit components.

To acquaint you with the Model PS-2, a photograph of the instrument's front panel is shown in Fig. 4. At the upper-left you can see the easy-to-read DC voltmeter, which has a scale of 0 to 20 volts divided into 1-volt markings. It gives a reasonably accurate indication of voltage for both output circuits.

The center meter has a 10-amp scale, each marking representing ½ amp. This panel instrument monitors current for the 5-amp output circuit, and is used in conjunction with the terminals labeled 5 AMPERES and COMMON. The high-current circuit is used for auto and marine radios, battery charging, electroplating, and powering various



"MAYBE HE SHOULD PLAY SOMETHING LESS FRIGHTENING 'TILL HE GETS USED TO STEREO SOUND"

For sheer realism, you just can't beat a Webster Stereo-Ceramic cartridge! But, be realistic... stereo is now beyond the novelty stage. New stereo discs are being released daily — in ever-increasing numbers. So when you replace a cartridge, sell your customer on a Webster Stereo-Ceramic. Tell 'em it plays standard LP's and 78's in addition to the new stereo discs. They'll marvel at the improved performance. And, you'll appreciate the easy installation with one universal mounting bracket that fits any standard arm.

**REPLACE WITH WEBSTER... IT PAYS!**

stereo-ceramic ...



SC-TD Stereo turn-under — with .7 mil diamond and 3 mil sapphire stylii. \$29.50\*



SC-1D Stereo single needle — with .7 mil diamond stylus. \$24.50\*



MC-1 78 rpm single needle — with 3 mil sapphire stylus. \$7.50\*

\* List prices — standard discounts apply.

ELECTRONICS DIVISION  
**WEBSTER ELECTRIC**  
 RACINE · WIS



franklin adv. 1129

# THE HANDIEST TESTER YOU CAN HAVE IN YOUR KIT



## THE ACME ELECTRIC T-8394 VOLTAGE ADJUSTOR

Smart service men, who like to save time and make more money by doing so, are using the Acme Electric T-8394M Voltage Adjustor on every service call. With this unit, varying voltage conditions ranging from 95 to 125 volts input can be simulated. Under these varying voltage conditions defective components that function properly at normal voltage, but cause trouble at low voltage or over voltage can be located and replaced.

And, in thousands of instances, service customers have insisted on buying this handy unit from the service man so that they may maintain a normal voltage at the set and enjoy top TV reception.

Furnished complete: primary cord and plug; secondary receptacle; accurate meter indicates output voltage; control switch regulates secondary voltage. Compact, inexpensive.

See this at your dealers.

ACME ELECTRIC CORPORATION  
949 WATER STREET CUBA, NEW YORK



electronic equipment requiring up to a 5-amp drain.

A milliammeter is located at the upper-right of the panel and has a 75-ma scale marked off in 5-ma divisions. The terminals labeled 75 MILLIAMPS and COMMON are used for this special low-current circuit. The fuse located directly below the milliammeter is a series-protective device. Its exposed contacts are isolated from the AC supply line and the fuse can safely be changed even with the equipment on. This fuse actually has two purposes: one, it protects the meter movement against currents in excess of 1/16 amp; and two, the user can easily insert any lower-value fuse he deems necessary to protect the circuit under test.

The large knob near the center of the front panel is the voltage output control. Before applying power to any load, this knob should be at its maximum counter-clockwise rotation. It's a good idea to use this control to turn the unit on and off in conjunction with the toggle switch located at the left edge of the panel. As an added protection feature, the supply has a 3-amp line fuse which can be seen directly below the on-off switch in Fig. 4.

### Caps, Coils or Circuits

Aerovox Corp., New Bedford, Mass., has recently developed a completely new piece of test equipment combining a capacitor tester, frequency meter, and signal generator in one portable unit. Pictured in



Fig. 5. New Aerovox LC Checker can be used to make a wide variety of tests.

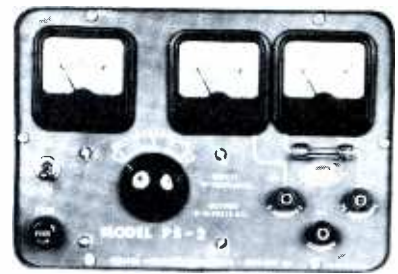

Fig. 4. Close-up of Model PS-2 front panel reveals its dual output facilities.

Fig. 5, the Model 97 LC Checker determines capacitance, inductance, or resonant frequency by use of a built-in RF oscillator and unique inductive probe.

Specifications and features are:

1. Power Requirements—115 volts AC, 60 cps; power consumption 30 watts.
2. Capacitance Measurement—5 ranges covering from approximately 200 mmf to 3.5 mfd, capacitors above or below this range may be measured by placing known values in series or parallel; accuracy  $\pm 20\%$  on all bands; separate test for capacitor leakage resistance provided.
3. Test Signal Output — 6 ranges available covering frequencies from 75 kc to 44 mc, continuous tuning provided; accuracy  $\pm 3\%$  on bands from 75 kc to 14.5 mc and  $\pm 5\%$  on band from 13 mc to 4 mc; special crystal jack provided for controlling RF output.
4. Inductance Measurement — coil connected in parallel with known capacity and value calculated by resonant frequency reading; special .001-mfd capacitor available as accessory; inductance vs. frequency chart provided in manual.



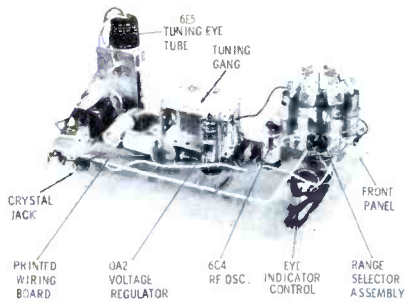

Fig. 6. Components and printed wiring in Model 97 make a light-weight unit.

When I had the opportunity to examine this instrument in the lab, the first thing I noticed was its light-weight construction. Although the instrument has outer dimensions of 13" X 8½" X 6", it weighs only 6½ pounds, which naturally lends to its portability and stems primarily from the use of the semi-printed circuit chassis pictured in Fig. 6. The entire chassis including selector switch, tuning-eye tube, and printed board are mounted on the instrument's front panel.

In addition to the applications evident from the specifications, here is a list of uses outlined in the instruction manual and tested in our lab:

1. Resonant-frequency measurement of RF chokes and tuned circuits.
2. Resonant frequency of antennas.
3. Determining fundamental frequencies of crystals.
4. Locating parasitic circuits in transmitters.
5. Use as a signal generator for signal substitution.
6. Crystal-controlled marker generator.
7. Checking frequency range of oscillators and signal generators.
8. Aligning RF and IF circuits.
9. Tracking superhet oscillators.
10. Alignment of TV traps, sound and video IF's.

In Fig. 5, the LC Checker is shown being used to measure the value of a typical paper-tubular

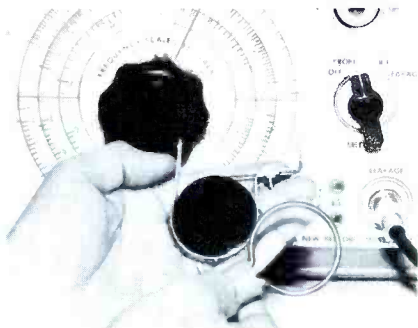

Fig. 7. Special probe assembly used in conjunction with Aerovox instrument.



Write for the latest Oxford catalog





**OXFORD Components, Inc.**  
 Subsidiary of Oxford Electric Corp.  
 556 West Monroe Chicago 6, Ill  
 Export: Roburn Agencies, New York City  
 In Canada: Atlas Radio Corp., Ltd., Toronto

# MAKE SURE IT FITS! OXFORD SPEAKERS

When you order a speaker (for replacement or original installation), demand units that meet your most exacting needs.

Each OXFORD SPEAKER is "tailor-designed" to actually "fit the application."

The next time you specify speakers, make certain they fit the job by selecting OXFORD . . . unsurpassed quality for over thirty years.

<p><b>RADIO &amp; TV SPEAKERS</b></p>  <p>OXFORD Speakers are used by more original set manufacturers — find out why!</p>	<p><b>OUTDOOR SPEAKERS</b></p>  <p>For rugged, steady performance under any conditions, OXFORD Weather-proof speakers will meet the need.</p>
<p><b>DUAL CONE HI-FI SPEAKERS</b></p>  <p>Oxford's newest development to provide maximum performance. For Hi-Fi and rear deck applications.</p>	<p><b>PORTABLE RADIO SPEAKERS</b></p>  <p>More Oxford speakers are used in portable sets than ever before . . . there must be reasons!</p>

(Advertisement)

## latest JACKSON tube test data

TUBE TYPE	MODEL 448		MODEL 115/715/561	
	FIL. D.	CIRCUIT E.	FIL. X.	PLATE YZ
6EH8	5.0	A124	5.0	43 70S
6EH8	6.3	A124	6.3	43 91R
6EH8	6.3	A124	6.3	43 91L
6EH8	6.3	A124	6.3	43 91M
6EH8	6.3	A124	6.3	43 91N
6EH8	6.3	A124	6.3	43 91O
6EH8	6.3	A124	6.3	43 91P
6EH8	6.3	A124	6.3	43 91Q
6EH8	6.3	A124	6.3	43 91R
6EH8	6.3	A124	6.3	43 91S
6EH8	6.3	A124	6.3	43 91T
6EH8	6.3	A124	6.3	43 91U
6EH8	6.3	A124	6.3	43 91V
6EH8	6.3	A124	6.3	43 91W
6EH8	6.3	A124	6.3	43 91X
6EH8	6.3	A124	6.3	43 91Y
6EH8	6.3	A124	6.3	43 91Z
6EH8	6.3	A124	6.3	43 91A
6EH8	6.3	A124	6.3	43 91B
6EH8	6.3	A124	6.3	43 91C
6EH8	6.3	A124	6.3	43 91D
6EH8	6.3	A124	6.3	43 91E
6EH8	6.3	A124	6.3	43 91F
6EH8	6.3	A124	6.3	43 91G
6EH8	6.3	A124	6.3	43 91H
6EH8	6.3	A124	6.3	43 91I
6EH8	6.3	A124	6.3	43 91J
6EH8	6.3	A124	6.3	43 91K
6EH8	6.3	A124	6.3	43 91L
6EH8	6.3	A124	6.3	43 91M
6EH8	6.3	A124	6.3	43 91N
6EH8	6.3	A124	6.3	43 91O
6EH8	6.3	A124	6.3	43 91P
6EH8	6.3	A124	6.3	43 91Q
6EH8	6.3	A124	6.3	43 91R
6EH8	6.3	A124	6.3	43 91S
6EH8	6.3	A124	6.3	43 91T
6EH8	6.3	A124	6.3	43 91U
6EH8	6.3	A124	6.3	43 91V
6EH8	6.3	A124	6.3	43 91W
6EH8	6.3	A124	6.3	43 91X
6EH8	6.3	A124	6.3	43 91Y
6EH8	6.3	A124	6.3	43 91Z
6EH8	6.3	A124	6.3	43 91A
6EH8	6.3	A124	6.3	43 91B
6EH8	6.3	A124	6.3	43 91C
6EH8	6.3	A124	6.3	43 91D
6EH8	6.3	A124	6.3	43 91E
6EH8	6.3	A124	6.3	43 91F
6EH8	6.3	A124	6.3	43 91G
6EH8	6.3	A124	6.3	43 91H
6EH8	6.3	A124	6.3	43 91I
6EH8	6.3	A124	6.3	43 91J
6EH8	6.3	A124	6.3	43 91K
6EH8	6.3	A124	6.3	43 91L
6EH8	6.3	A124	6.3	43 91M
6EH8	6.3	A124	6.3	43 91N
6EH8	6.3	A124	6.3	43 91O
6EH8	6.3	A124	6.3	43 91P
6EH8	6.3	A124	6.3	43 91Q
6EH8	6.3	A124	6.3	43 91R
6EH8	6.3	A124	6.3	43 91S
6EH8	6.3	A124	6.3	43 91T
6EH8	6.3	A124	6.3	43 91U
6EH8	6.3	A124	6.3	43 91V
6EH8	6.3	A124	6.3	43 91W
6EH8	6.3	A124	6.3	43 91X
6EH8	6.3	A124	6.3	43 91Y
6EH8	6.3	A124	6.3	43 91Z
6EH8	6.3	A124	6.3	43 91A
6EH8	6.3	A124	6.3	43 91B
6EH8	6.3	A124	6.3	43 91C
6EH8	6.3	A124	6.3	43 91D
6EH8	6.3	A124	6.3	43 91E
6EH8	6.3	A124	6.3	43 91F
6EH8	6.3	A124	6.3	43 91G
6EH8	6.3	A124	6.3	43 91H
6EH8	6.3	A124	6.3	43 91I
6EH8	6.3	A124	6.3	43 91J
6EH8	6.3	A124	6.3	43 91K
6EH8	6.3	A124	6.3	43 91L
6EH8	6.3	A124	6.3	43 91M
6EH8	6.3	A124	6.3	43 91N
6EH8	6.3	A124	6.3	43 91O
6EH8	6.3	A124	6.3	43 91P
6EH8	6.3	A124	6.3	43 91Q
6EH8	6.3	A124	6.3	43 91R
6EH8	6.3	A124	6.3	43 91S
6EH8	6.3	A124	6.3	43 91T
6EH8	6.3	A124	6.3	43 91U
6EH8	6.3	A124	6.3	43 91V
6EH8	6.3	A124	6.3	43 91W
6EH8	6.3	A124	6.3	43 91X
6EH8	6.3	A124	6.3	43 91Y
6EH8	6.3	A124	6.3	43 91Z
6EH8	6.3	A124	6.3	43 91A
6EH8	6.3	A124	6.3	43 91B
6EH8	6.3	A124	6.3	43 91C
6EH8	6.3	A124	6.3	43 91D
6EH8	6.3	A124	6.3	43 91E
6EH8	6.3	A124	6.3	43 91F
6EH8	6.3	A124	6.3	43 91G
6EH8	6.3	A124	6.3	43 91H
6EH8	6.3	A124	6.3	43 91I
6EH8	6.3	A124	6.3	43 91J
6EH8	6.3	A124	6.3	43 91K
6EH8	6.3	A124	6.3	43 91L
6EH8	6.3	A124	6.3	43 91M
6EH8	6.3	A124	6.3	43 91N
6EH8	6.3	A124	6.3	43 91O
6EH8	6.3	A124	6.3	43 91P
6EH8	6.3	A124	6.3	43 91Q
6EH8	6.3	A124	6.3	43 91R
6EH8	6.3	A124	6.3	43 91S
6EH8	6.3	A124	6.3	43 91T
6EH8	6.3	A124	6.3	43 91U
6EH8	6.3	A124	6.3	43 91V
6EH8	6.3	A124	6.3	43 91W
6EH8	6.3	A124	6.3	43 91X
6EH8	6.3	A124	6.3	43 91Y
6EH8	6.3	A124	6.3	43 91Z
6EH8	6.3	A124	6.3	43 91A
6EH8	6.3	A124	6.3	43 91B
6EH8	6.3	A124	6.3	43 91C
6EH8	6.3	A124	6.3	43 91D
6EH8	6.3	A124	6.3	43 91E
6EH8	6.3	A124	6.3	43 91F
6EH8	6.3	A124	6.3	43 91G
6EH8	6.3	A124	6.3	43 91H
6EH8	6.3	A124	6.3	43 91I
6EH8	6.3	A124	6.3	43 91J
6EH8	6.3	A124	6.3	43 91K
6EH8	6.3	A124	6.3	43 91L
6EH8	6.3	A124	6.3	43 91M
6EH8	6.3	A124	6.3	43 91N
6EH8	6.3	A124	6.3	43 91O
6EH8	6.3	A124	6.3	43 91P
6EH8	6.3	A124	6.3	43 91Q
6EH8	6.3	A124	6.3	43 91R
6EH8	6.3	A124	6.3	43 91S
6EH8	6.3	A124	6.3	43 91T
6EH8	6.3	A124	6.3	43 91U
6EH8	6.3	A124	6.3	43 91V
6EH8	6.3	A124	6.3	43 91W
6EH8	6.3	A124	6.3	43 91X
6EH8	6.3	A124	6.3	43 91Y
6EH8	6.3	A124	6.3	43 91Z
6EH8	6.3	A124	6.3	43 91A
6EH8	6.3	A124	6.3	43 91B
6EH8	6.3	A124	6.3	43 91C
6EH8	6.3	A124	6.3	43 91D
6EH8	6.3	A124	6.3	43 91E
6EH8	6.3	A124	6.3	43 91F
6EH8	6.3	A124	6.3	43 91G
6EH8	6.3	A124	6.3	43 91H
6EH8	6.3	A124	6.3	43 91I
6EH8	6.3	A124	6.3	43 91J
6EH8	6.3	A124	6.3	43 91K
6EH8	6.3	A124	6.3	43 91L
6EH8	6.3	A124	6.3	43 91M
6EH8	6.3	A124	6.3	43 91N
6EH8	6.3	A124	6.3	43 91O
6EH8	6.3	A124	6.3	43 91P
6EH8	6.3	A124	6.3	43 91Q
6EH8	6.3	A124	6.3	43 91R
6EH8	6.3	A124	6.3	43 91S
6EH8	6.3	A124	6.3	43 91T
6EH8	6.3	A124	6.3	43 91U
6EH8	6.3	A124	6.3	43 91V
6EH8	6.3	A124	6.3	43 91W
6EH8	6.3	A124	6.3	43 91X
6EH8	6.3	A124	6.3	43 91Y
6EH8	6.3	A124	6.3	43 91Z
6EH8	6.3	A124	6.3	43 91A
6EH8	6.3	A124	6.3	43 91B
6EH8	6.3	A124	6.3	43 91C
6EH8	6.3	A124	6.3	43 91D
6EH8	6.3	A124	6.3	43 91E
6EH8	6.3	A124	6.3	43 91F
6EH8	6.3	A124	6.3	43 91G
6EH8	6.3	A124	6.3	43 91H
6EH8	6.3	A124	6.3	43 91I
6EH8	6.3	A124	6.3	43 91J
6EH8	6.3	A124	6.3	43 91K
6EH8	6.3	A124	6.3	43 91L
6EH8	6.3	A124	6.3	43 91M
6EH8	6.3	A124	6.3	43 91N
6EH8	6.3	A124	6.3	43 91O
6EH8	6.3	A124	6.3	43 91P
6EH8	6.3	A124	6.3	43 91Q
6EH8	6.3	A124	6.3	43 91R

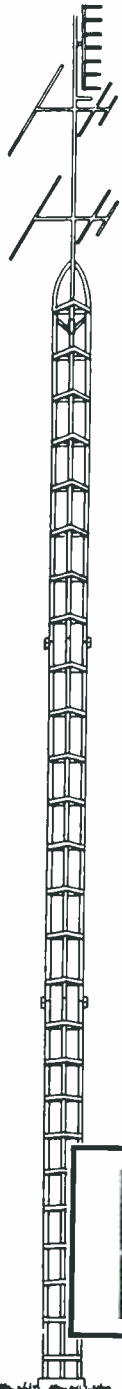

**SAFE**  
in winds  
up to  
**80 m.p.h...**

WITHOUT A SINGLE  
GUY WIRE



**Towers**

*faster installation  
... far longer life*

- Free standing up to 50 ft.
- Exclusive welded load bearers take all strain off joints — provide free drainage, eliminating trapped moisture and corrosion.
- No bolt holes in structural frame to rust, rip or cause weakness.
- Electro plated with zinc for lasting, lustre finish.
- Easy to install, dismantle, or climb for service.

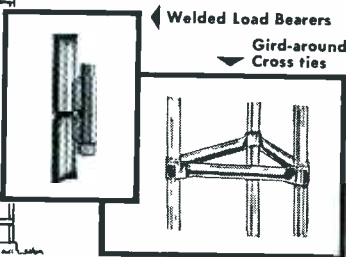

KTV are the most advanced towers ever designed for residential or commercial use — both in appearance and construction. Tested and proved for greater strength, KTV Towers are available by the 10 ft. section, or in complete kits of 10, 20, 30, 40 and 50 ft. They can be installed on a pitch roof, flat roof, or on the ground. Prices are remarkably low.

SEND FOR FREE  
ILLUSTRATED FOLDER

**KTV Tower**

AND COMMUNICATION COMPANY  
SULLIVAN, ILLINOIS

capacitor. For this operation, a special inductive loop and "C" probe assembly supplied with the unit is employed. A closeup of this apparatus is pictured in Fig. 7. The probe assembly is an adjustable C-clamp device which enables the user to make the necessary circuit connection as close as possible to the body of the component. The inductive loop or ring attached to the end of the probe cable snaps over this "C" assembly and thus forms a means of RF coupling.

I found that when the instrument's RF oscillator is tuned through the resonant frequency of the circuit or component tested, a certain amount of RF energy is removed from the oscillator tank circuit. This causes RF drive on the oscillator tube to drop, and thus produces a reduction in grid current. Acting as a grid-dip meter, the eye tube located in the grid circuit gives a visual indication of the resonant frequency.

#### Counter or Home-Call Tube Tester

To solve the serviceman's problem of evaluating the operational condition of vacuum tubes both at the bench and in the field, Vis-U-All Products Co., Grand Rapids, Mich., has recently introduced their Model V1001 Tubechecker. Shown in operation in Fig. 8, the instrument checks tubes rapidly by featuring only three control knobs, set-up

data for 42 of the most common tube types on the front panel, and a complete tube chart inside its lid.

Specifications and features are:

1. Power Requirements—105/125 volts, 60 cps; high or low line-voltage compensation provided by simple wiring change; detachable AC cord supplied.
2. Tube Tests — checks more than 400 tube types, emission automatically indicated on panel meter; provision for grid-to-cathode, heater-to-cathode and gassy-shorts test; individual sections or multi-purpose tubes checked separately.
3. CRT/Rectifier Tests — picture tubes checked by using special adapter cable available as accessory, condition of tube indicated on panel meter; selenium rectifiers tested using adapter, condition indicated on panel meter.
4. Size and Weight — portable case 17" X 11 $\frac{3}{8}$ " X 6", 11 $\frac{1}{2}$  lbs.

In order to familiarize you with the Model V1001, let's take a closer look at its panel (see Fig. 9). To check a tube with the instrument, one end of the AC cheater cord (A) is plugged into an AC outlet and the other into the interlock receptacle on the front panel. There is no on-off switch — so as I plugged the cord in, the short indicator (B) began to glow. Incidentally, the manufacturer states that continuous operation will not harm the unit.

My next step was to select a heater voltage for the tube. Referring to the setup information, I set the FILAMENT VOLTS switch (C) to the value stipulated. I placed the SELECTOR switch (D) in one of

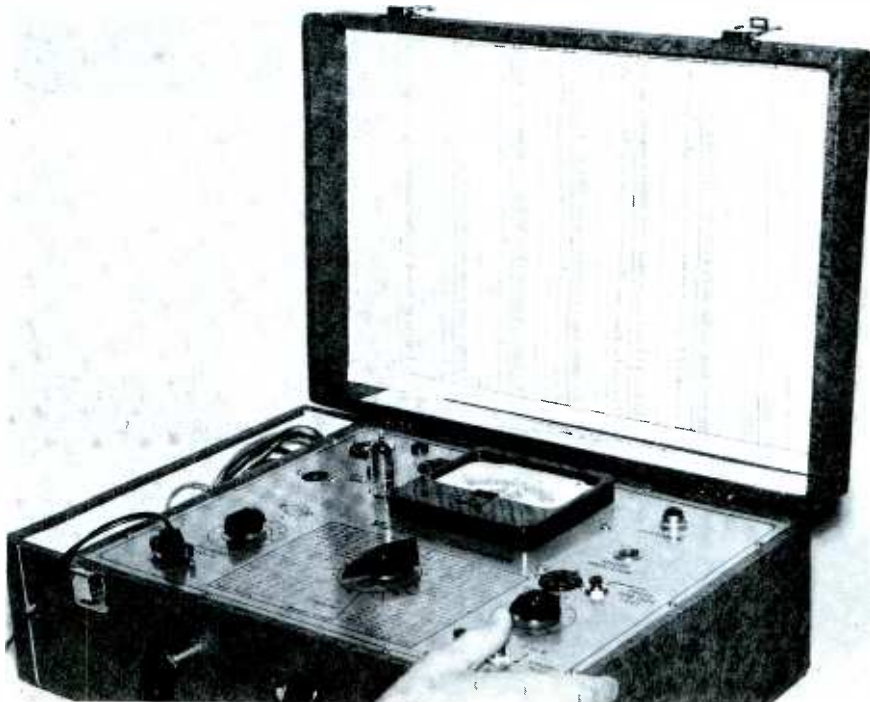

Fig. 8. Vis-U-All Tubechecker has only 3 control knobs.



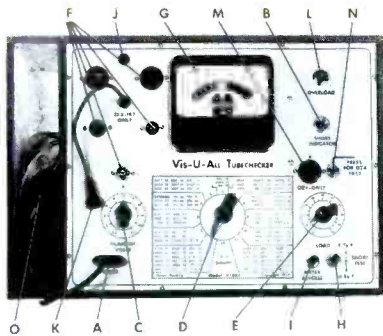

Fig. 9. Set-up data for most commonly-used tubes is printed on the front panel.

the 12 positions called for, and adjusted the LOAD control (E), which is calibrated from zero to 100 in steps of 5, to the proper setting. Placing the tube in one of the test sockets (F), I read its condition on the 4½" panel meter (G). The meter scale is graduated in BAD?-GOOD and a linear scale of zero to 1 with 50 divisions representing .02 each.

To test the tube for shorts, I moved the SHORT TEST lever (H) up and then down, noting in each case whether the short indicator went out or remained lit. If the neon bulb goes out, no short exists — but if it glows brightly, the tube is shorted. If, on the other hand, the bulb glows dimly, it is usually an indication of either leakage or gas.

Other items pointed out in Fig. 9 are: METER REVERSE button (I) used on certain tubes for proper meter deflection; test-lead connector (J) for all grid- and plate-cap tubes; test lead and special jack (K) for 1X2 and 1B3 plate connections only; overload indicator (L) which is a #47 pilot lamp; a special octal socket (M) and test button (N) for OZ4 tubes only; and a CRT adapter cable (O) for testing picture tubes.

While reading over the instruction manual for the Model V1001, I noticed that the sensitivity of the short - indicating circuit can be changed to suit the user. The instrument comes designed to reveal leakage up to 3.5 megohms; however, for more or less sensitivity, the resistor connected across the neon bulb may be replaced with a value specified in the manual to obtain leakage indications from 1 megohm up to 7.5 megohms. ▲



## SUITS NEED PRESSING— MERIT DEFLECTION YOKES DO NOT!

Merit deflection yokes are cosine wound TO FORM, not pressed. Pressing can lead to distortion and poor focusing. Pressing after winding frequently causes breakdown.

MERIT COILS AND TRANSFORMERS HAVE  
"BUILT-IN" ADVANTAGES.



Each Merit yoke is  
100% LIVE TESTED



# COMPARE IT WITH MERIT

MERIT COIL AND TRANSFORMER CORP.  
MERIT PLAZA • HOLLYWOOD, FLORIDA

you learn **MORE**  
from a **SAMS BOOK**

**IT'S A FACT:**  
proved by more than  
**1,000,000**  
**SAMS BOOKS**  
bought to date

**NEW BOOK RELEASE**



**"Servicing HI-FI and Associated Audio Equipment"**  
most complete service data available on popular make Hi-Fi components...

**VOL. 1.** Covers 26 models (power amplifiers, preamps, AM-FM tuners, P.A. amplifiers) produced during 1956-58. Includes section on planning, installing, maintaining hi-fi music systems. 160 pages, 8½ x 11". Only... **\$2.95**

**VOL. 2.** Covers 27 models of power amplifiers, preamps, AM-FM tuners, P.A. amplifiers produced in 1956-58. Special section on stereo music systems. Cumulative index. 160 pages, 8½ x 11". Only... **\$2.95**

**CURRENT BEST SELLER**



**"TV Servicing Guide"**  
by Deane & Young  
Written by technicians for technicians

Shows how to apply proper trouble shooting techniques based on an analysis of symptoms. Most trouble symptoms are illustrated by picture-tube screen photos and possible causes for each symptom are given. First chapter covers general troubleshooting and isolating procedure; remaining chapters treat each section of the receiver separately. 132 pages, 8½ x 11". Only... **\$2.00**

**ORDER TODAY FROM YOUR SAMS DISTRIBUTOR OR MAIL COUPON**

**HOWARD W. SAMS & CO., INC.**

Order from your Sams Distributor today, or mail to Howard W. Sams & Co., Inc., Dept. 3-J8 2201 E. 46th St., Indianapolis 5, Ind.

Send me the following books:

- "Servicing Hi-Fi". Vol. 1.
- "Servicing Hi-Fi". Vol. 2.
- "TV Servicing Guide". \$.....enclosed
- Send me your Free Book List

Name.....

Address.....

City.....Zone.....State.....

**Industrial Electronics**

(Continued from page 25)

Fig. 6. A center cathode is surrounded by two sets of grids, one set controlling even - numbered targets and the other odd-numbered targets. Spades, shaped somewhat like horse-shoes, are placed in front of the targets, and each spade is brought out to a separate base pin. Targets form the outermost ring of elements, and are also provided with individual base pins.

A constant magnetic field provides a grouping force for electrons, and a variable electrostatic field directs the electron stream to the proper target. An electrostatic field is usually represented by equipotential lines. The lines in Fig. 7, extending from spade No. 1 around the cathode and back to spade No. 2, connect all points which have the same electron pulling power. Line 120 means that the force exerted on an electron is the equivalent of 120 volts.

The path an electron travels when spade No. 0 is very near zero voltage and the spades on either side are at a potential of 200 volts resembles a stretched spring. This is the curl effect of a magnetic field on an electron. In addition to the magnetic field, there are electrostatic fields extending from spade number 9 at 200-volts, around the cathode to spade number 1 at 200 volts. The electron is attracted to positive spade No. 1; however, influenced by the magnetic field, it travels along an electrostatic line of force

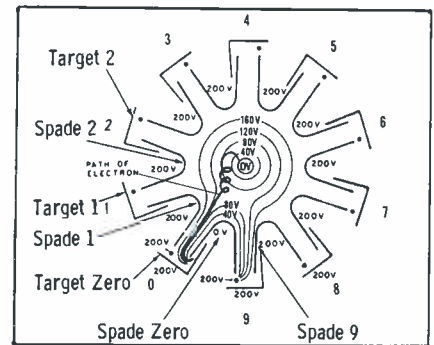

**Fig. 7. Electrons in MBS tube follow a spiral path from cathode to a target.**

toward the low voltage spade until it reaches the positive target. Counting is performed by driving the grids negative with pulses from a conventional Eccles-Jordan circuit. A driving pulse is applied to the grid of the conducting target. The electron stream is then directed, by the magnetic field, to the next counterclockwise spade. The spade conducts through a large-value load resistor, causing the spade voltage to decrease almost to zero. The resultant change in the electrostatic field directs the majority of electrons to the target; however, the remaining spade conduction is sufficient to maintain the reduced spade voltage.

Driving pulses are applied alternately to the odd- and even-numbered grids. This allows blockage of a conducting target without affecting the next counterclockwise target, which must have a positive grid to conduct.

**Nixie Indicating Tube**

The glow developed within a gas tube is concentrated around its cathode

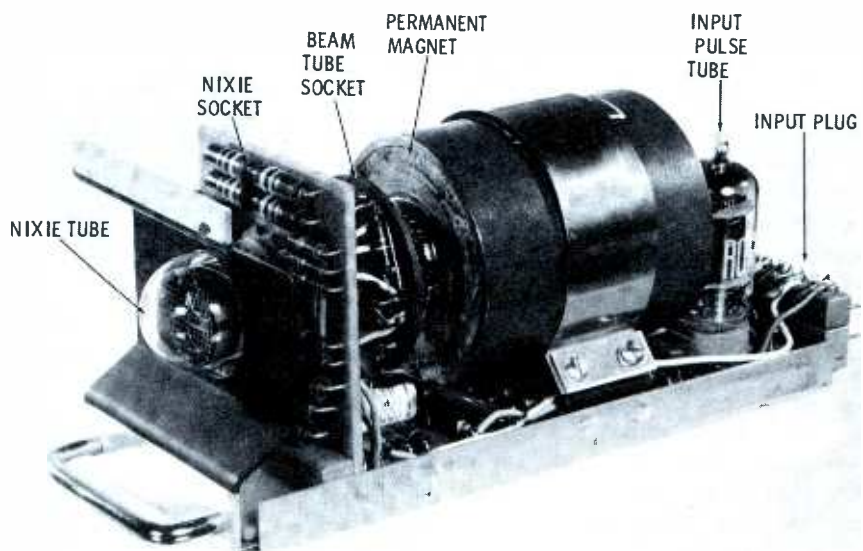

**Fig. 8. Nixie and MBS tubes combine operations in this compact plug-in unit.**



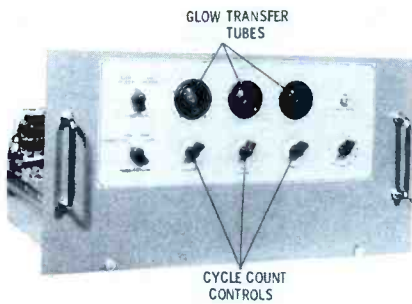

Fig. 9. Exact forge control is provided by this simple weld-current computer.

ode, and when this element is shaped like a number, the glow formation has the same pattern. This is the whole story of the Nixie indicating tube. There are ten separate cathodes in the center, one in the shape of each digit from 0 to 9. Each has a separate base-pin connection, so that a potential greater than the ionizing voltage may be impressed between any cathode and the common plate to produce a glow and indicate the cathode actuated.

A complete plug-in unit is shown in Fig. 8. Voltages and input pulses are coupled through connectors provided at the rear of the unit. A permanent magnet surrounds the counting tube which is socketed toward the front. The read-out mechanism is a Nixie indicating tube with one cathode per MBS spade. Sockets for the switching and indicating tubes are close together to reduce stray capacitance which would otherwise reduce operating speed.

#### Process Computers

More and more, industrial processes are falling under electronic domination through the use of computers, which sense, compare, and correct intermediate as well as final characteristics of a product. The process control computer need not be a complex electronic giant. A small unit employing several tubes may be all that is required. To give you an example, Fig. 9 shows a computer control unit which senses the number of cycles of weld current used by a forge welder. Control information is set up by the timing controls shown in the center of the photograph. Glow tubes are used to count and indicate the number of cycles used. After a predetermined number of cycles, the unit stops the forge and waits for the next operation. ▲

IN ALL THE WORLD . . .

# NO BETTER CAPACITOR

than the Newest Miniaturized

# ELMENCO

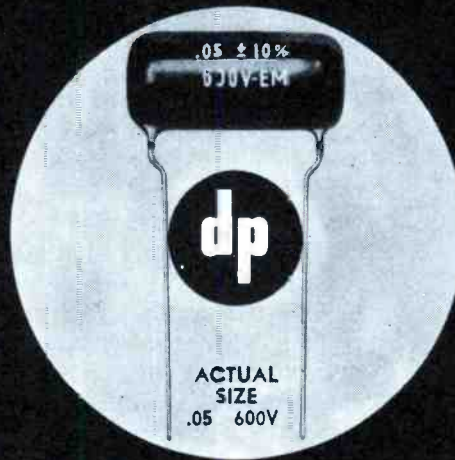

**Tubular**

Another ELMENCO "first" is announced with the introduction of the new dipped tubular capacitor. The "DP" series is designed for use in a variety of circuits ranging from TV by-pass to critical industrial applications requiring stringent electrical and environmental characteristics. New high levels of ruggedness, stability, and reliability have been achieved. The new ELMENCO DP Tubulars are miniaturized for transistor circuitry yet compare favorably in price with commercial general purpose units.

#### FEATURES:

- HIGH TEMPERATURE OPERATION
- SUPERIOR MOISTURE RESISTANCE
- LONG LIFE AND HIGH RELIABILITY
- HIGH INSULATION RESISTANCE
- ALL VALUES  $\pm 10\%$  TOLERANCE
- TRANSISTOR AND PRINTED CIRCUIT APPLICATION

Look For The  
**ELMENCO**  
"EM"  
Brand Name  
On All  
DP CAPACITORS



See Your Local

# ARCO

Distributor

ARCO ELECTRONICS INC. • NEW YORK 13, NEW YORK

performance  
proven in more  
than 500,000  
homes



# UHF CONVERTERS

No matter where you are — primary or fringe area — there's a B-T UHF converter that makes any TV set a modern, powerful 82-channel receiver. New FCC tuner standards\* are met by these B-T Converters.

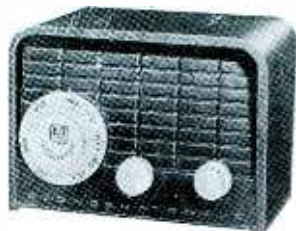

for superior reception  
in fringe areas the

## BTU-2<sub>R</sub>

precise 300-ohm impedance match; high gain—high stability; low noise factor; double tuned input; dual speed channel selector for easy, accurate tuning  
only 39.95



for primary areas — top  
performance at low cost

## MODEL 99<sub>R</sub>

precise 300 ohm impedance match; double tuned RF section; one knob tuning; drift-free performance  
only 22.95

B-T converters are UL approved, CSA approved and approved by actual performance in more than 500,000 American homes.

Sold by Electronic Parts Distributors

For further information write: Dept. PF-9

Blonder-Tongue Laboratories, Inc.

9 Alling Street Newark 2, N. J.

\*Models 99r and BTU-2r comply with tuner limits of FCC rules, Part 15, of 1000 UV/M — Hazeltine Research Corp. — report #57041.

### Shop Talk

(Continued from page 22)

If C14 is shorted, the screen-grid and plate elements of the tube will have no voltage and the entire stage will be completely inoperative. R23 would undoubtedly be burned open. For verification, a voltmeter check would be necessary.

If C14 is partially shorted, stage gain will again be low. The signal-injection test will not provide any conclusive results. However, it will show up the low gain of the stage and voltage checks would immediately pinpoint the trouble.

It is interesting to note that when the plate circuit has its own bypass capacitor (distinct from the screen-grid capacitor), the same test will usually work as well. For example, consider the circuit of Fig. 3. To check the condition of the plate bypass capacitor, we can proceed as follows. Touch the signal probe to point A, where the bypass capacitor is connected to the circuit. If the capacitor is okay, little or no signal will reach the plate and be transferred to the next stage. However, if the capacitor is open, a fairly strong signal will reach the picture tube. As a matter of practical interest, with the bypass capacitor open, signal injection at the plate and at point A will produce very nearly the same strength signal at the output of the system.

### Applying the System to Tuners

In nearly all stages of a TV receiver, the various tube elements and other circuit components are readily accessible from the underside of the chassis. Front-end tuners,

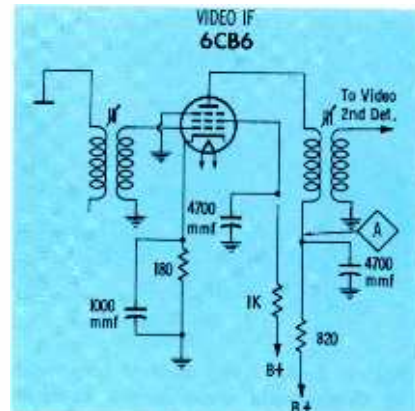

Fig. 3. IF circuit in which both screen and plate bypass capacitors are used.

however, are encased in highly compact metal housings. In order to get at any of the tuner parts, aside from the tubes, part of the housing must be removed. Some of the components will be fairly easy to reach; others will be positioned behind an inner shield, another part, or tucked away in a hard-to-reach corner. Finally, because of the high frequencies involved, even slight changes in component positions can affect over-all tuner alignment.

The best answer to all this is to stay out of the tuner as much as possible and do whatever checking you can from the top of the unit. Signal injection lends itself admirably to this purpose, aided by the availability of special tube-socket adapters and the common practice by tuner manufacturers of providing a top-side terminal which connects into the grid circuit of the RF mixer. For those who may not have had occasion to use signal-injection techniques to check out a tuner, the following will be of interest.

Every tuner in current use con-

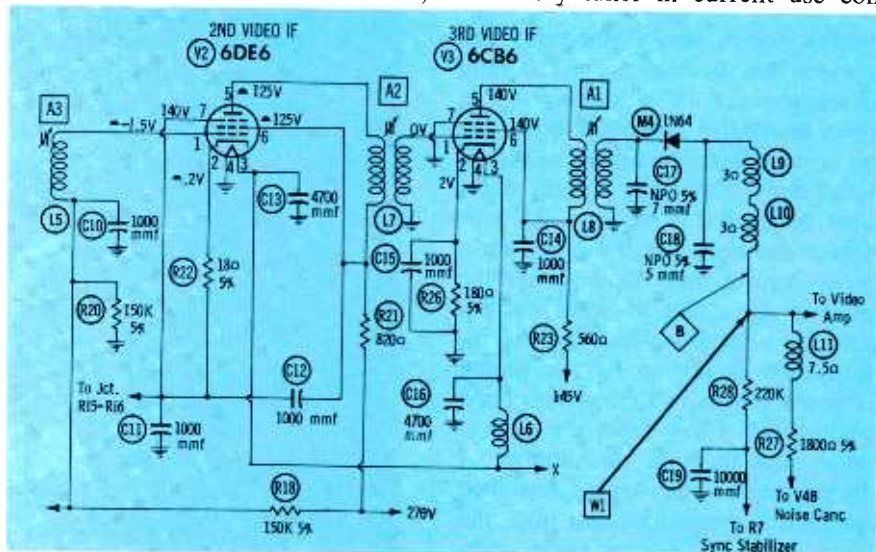

Fig. 2. Text explains how to test this circuit with signal-injection method.



**NEW! IMPROVED!**

**SENCORE**

TRC4

**TRANSISTOR  
CHECKER**

*Another  
Sencore  
Time-  
Saver*

America's newest,  
most popular test  
instruments

**NOW CHECKS:**

- ★ **Transistors** for opens, shorts, leakage and current gain. Includes new gain test on power transistors.
- ★ **Crystal Diodes** checks forward to reverse current ratio on all diodes.
- ★ **Selenium Rectifiers** checks forward and reverse currents.

Controls are accurately set for each transistor by referring to replaceable set-up chart on rear. Test leads or socket provides for fast hook-up.

See your parts distributor.

**SENCORE**

Mfg by **SERVICE  
INSTRUMENTS CORP.**  
171 OFFICIAL RD., ADDISON, ILL.

Cut out this ad now for further information

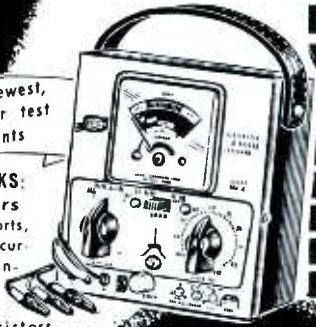

**ONLY \$17.95**  
SIMPLE TO OPERATE  
Dealer Net  
Cannot become obsolete.  
Approved by leading manufacturers

**FINEST TESTER-MERCHANDISER  
EVER DEVELOPED**

**Vis-U-All**

self service  
**TUBE  
TESTER**

Model V II



Counter model also available

Features only six tube sockets for simple operation, yet tests over 600 types of radio-TV tubes. Occupies minimum floor space, only 15" x 15". Most obsolescence-proof, has master-switch dial control to accommodate new tubes. Attractively designed, ruggedly built. Big tube storage capacity. And it's only \$199.95!

See your distributor or write for full details.

**VIS-U-ALL** products company  
303 Fuller N.E., Grand Rapids 3, Mich.

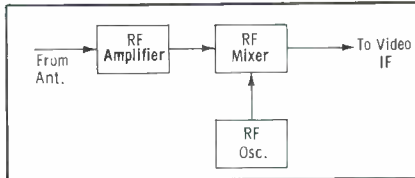

Fig. 4. Block diagram of the three stages used in all present-day TV tuners.

sists of three stages — RF amplifier, mixer, and RF oscillator (see Fig. 4). The RF amplifier receives the incoming signal, amplifies it, and forwards it on to the mixer. Here the RF signal combines with a signal developed by the oscillator, producing a sum frequency (which is of no use) and a difference frequency, which represents the IF signal.

If the RF amplifier becomes defective, no signal will reach the mixer and no IF signal will be produced. If the local oscillator should cease to function, the RF signal reaching the mixer will be unable, by itself, to produce the necessary IF signal. Thus, in the event that either the RF amplifier or the RF oscillator fails, no IF signal will be developed. Finally, if the mixer becomes defective, no matter what the other two stages do, nothing will reach the video IF system and no image will appear on the screen. It is evident, therefore, that all three stages must be operating in unison to produce a picture.

Armed with this knowledge, let's see how we can readily apply the signal injection method to quickly uncover a defective tuner stage, assuming that the receiver is operating normally back to the tuner. This means that we can apply a modulated IF signal to the grid of the 1st video IF stage and produce the horizontal bar pattern on the screen. To check the mixer stage, the signal is applied to its control grid. Normally the pattern will appear on the screen with about the same intensity obtained when the same signal is applied to the grid of the 1st video IF. The fact that image intensity remains unaltered means that the mixer provides very little gain. This is characteristic of mixer operation in general. However, if there is a noticeable drop in gain, the mixer stage may be suspected of being faulty.

Note that it is possible to perform the above signal injection without going inside the tuner because of the common practice of providing

better reception on  
1, 2 or 3 tv sets...  
with one antenna

**NEW**  **B-23**

**TWO-SET  
BOOSTER**



only \$23.95

From B-T comes the most important advance in better TV reception for 1958 — a broadband TV amplifier that boosts signal strength on all VHF channels and operates 1, 2 or 3 TV sets with one antenna — no tuning required.

**Combines two functions in one —**

- BOOSTS signal strength on 1 or 2 TV sets — up to 6 db gain operating two TV sets from one antenna.
- COUPLES 2 or 3 TV sets — using the present antenna. Outperforms non-powered couplers in any reception area by more than 2 to 1.

**Check these B-23 features:**

- Ideal for color — add a color TV set and keep present black-and-white set, use the same antenna — the result, sharper, clearer pictures on both sets
- Low noise figure — designed to work with new VHF sets
- Reduces interference
- Easily installed at antenna terminals of set
- Automatically amplifies channels 2-13
- Ideal small TV system

**For operating 3 to 8 TV sets, use the B-T Labs DA8-B — more than 10 db gain on all VHF channels.**

The DA8-B Distribution Amplifier is a broadband, all-channel unit that requires no tuning, impedance matching devices, pre-amps or other special fittings. Ideal for all small TV systems (garden apartments, motels, TV showrooms). Approved for color. Only \$94.50

The B-23, the DA8-B, and other B-T quality engineered products, are available at electronic parts distributors.

For further information, use coupon.

PF9

**B-T LABS** **BLONDER-TONGUE LABS., INC.**  
9 Alling Street, Newark 2, New Jersey

Please send me literature covering:

B-T B-23       B-T TV Accessories

Name \_\_\_\_\_

Address \_\_\_\_\_

City \_\_\_\_\_ Zone \_\_\_\_\_ State \_\_\_\_\_

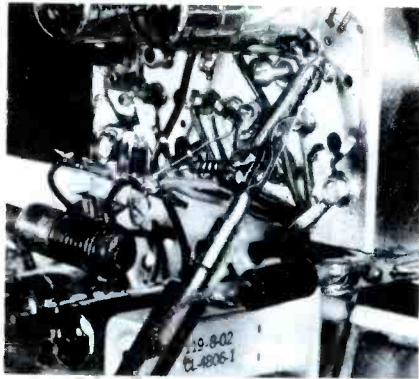

Fig. 5. Top-side test point is provided on most tuners for access to mixer grid.

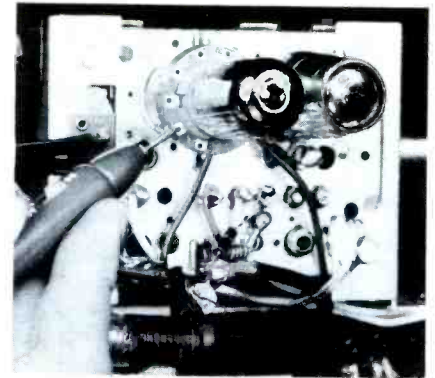
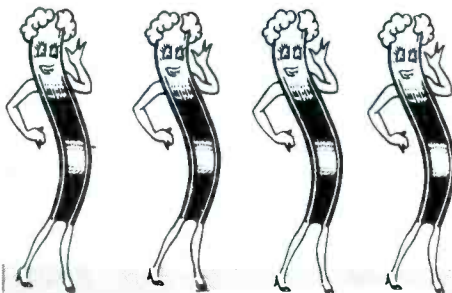

Fig. 6. Socket adapter provides direct access to each element of tuner tubes.



Which one can prove her  
**QUALITY?**

Most brands of twin lead look alike! Also, the price brands make the same claims of quality and performance as the top quality brands.

**What Reason . . . What Proof**

Can you give your customer that he is getting something better when he pays a little more for twin lead?

WITH  
**Columbia**  
**PERMALINE**

Your Customer has the reason

So GOOD that it's  
GUARANTEED up to 25 YEARS!

DISTINCTIVE APPEARANCE

HIGH MOLECULAR WT. POLYETHYLENE

DEVELOPED AFTER YEARS OF RESEARCH

See your Jobber . . .

Ask him about Permaline — and ask to see the Laboratory Report on weathering studies of Polyethylene.

Once you "Try" COLUMBIA . . . you'll want to always "Buy" Columbia . . . Because only, but only COLUMBIA gives you a complete guarantee for 25 YEARS.

AVAILABLE AT ALL LEADING DISTRIBUTORS

**Columbia**  
**WIRE & SUPPLY CO.**  
2850 IRVING PK. RD., CHICAGO 18

a mixer-grid test point on the top side of the tuner assembly (see Fig. 5).

The next step, which is just as simple, is to test the operation of the RF oscillator. The signal probe is left at the mixer grid, but now the signal frequency is altered to an RF value and the tuner set to operate at the same frequency, which may be any VHF channel from 2 to 13. If the oscillator is working, the RF signal will be converted to the IF frequency and passed through the receiver. If no pattern is displayed on the receiver picture tube, however, the local oscillator is not functioning normally.

The beauty of the foregoing test lies in its simplicity and thoroughness. Not only is it easy to perform, but it checks the local oscillator under *normal* operating conditions. If the oscillator combines with the injected signal to produce a normal screen image, it will combine with the transmitted station signal to produce a similar result. If desired, this check can be made on several channels but, generally speaking, if it functions on one channel, it will do the same on all other channels. Of course, there are times when the oscillator frequency will be off; the above test will show on which channels operation is normal and on which channels it is not, providing that the generator is accurately adjusted to the RF picture-carrier frequency of each channel tested.

The remaining stage in the tuner is the RF amplifier, and its operation is checked by application of an RF signal to the antenna terminals. A stronger pattern should now be displayed on the picture tube screen than when the same signal was applied to the mixer grid, due to the additional amplification of the RF stage. If no noticeable increase in gain is obtained, the RF amplifier circuit is not functioning properly.

When a defective stage is found, the tube should be checked, if this has not been done already. If the tube is good, the voltages at the various tube elements should be measured with the aid of an adapter between the tube and its socket (see Fig. 6).

Use of the adapter also permits the signal to be injected directly at various tube elements. For example, when the signal is applied to the

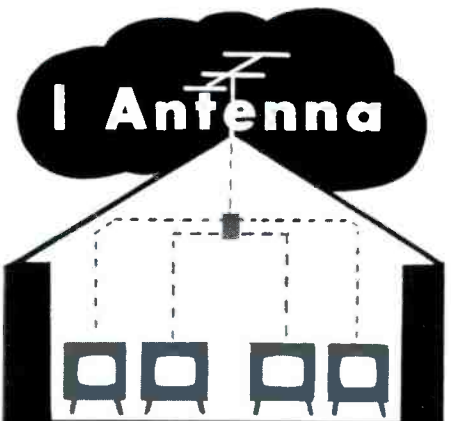

**4 Sets**

**MOSLEY**  
**4-Set Coupler**



LOW LOSS  
EFFECTIVE ISOLATION  
EFFICIENT SIGNAL  
DISTRIBUTION

Owners of Duplex or 4-unit Apartment Buildings will want you to install Mosley 4-Set Couplers!

Here's a Big profit-maker in a Big market!

Mosley 904, 4-Set Coupler  
\$6.25 List

Another Mosley Premium Quality TV Accessory!

**Mosley**  
*Electronics, Inc.*  
8622 ST. CHARLES ROCK ROAD  
ST. LOUIS 14, MISSOURI



# NEW *G-C* SERVICE AIDS

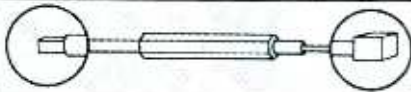

**G-C TRANSISTOR I.F. CORE ALIGNMENT TOOL**  
Nylon tool for many transistorized sets. Square end .055, rectangle nib end .047 x .078 to reach bottom slugs.  
No. 9440—11 3/4" long List \$1.00



**G-C TINNEMAN NUT REMOVER**  
Remove large and small Tinnerman nuts with just a twist; won't break studs.  
No. 9355 List \$1.47

**G-C COMBINATION INSPECTION LIGHT**  
Includes 3-way outlet and cheater cord, with clamp-on inspection light.  
No. 707 List \$5.00



FREE CATALOG... WRITE TODAY!

**GENERAL CEMENT MFG. CO.**

division of **TEXTRON INC.**  
Western Plant: Los Angeles 18, Calif.  
Main Plant: **ROCKFORD, ILLINOIS, U.S.A.**

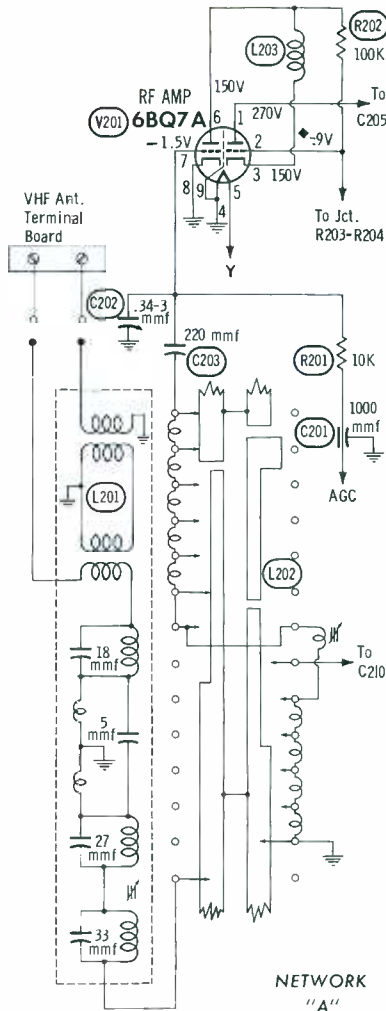

NETWORK "A"

Fig. 7. Interstage networks in tuner circuits such as this can be tested easily.

antenna terminals, it must pass through the network enclosed in the dotted rectangle labeled "A" in Fig. 7 before it reaches the control grid of the RF amplifier tube. If some component in this network is defective, it will prevent the signal, totally or partially, from reaching the tube. By means of the adapter, the signal can be injected directly at the grid of the tube and used to determine the condition of the network between the grid and the input terminals.

A precaution to observe when signals are injected at B+ voltage points is to employ a small blocking capacitor in the signal lead. Many signal generators have such a capacitor built in; where one is not present, an external unit should by all means be used.

Although there are a number of different tuners on the market, each with its own circuit arrangement, the testing procedure outlined above will apply to all of them. ▲



"I just dropped in to ask if you sell JENSEN NEEDLES."

# INJECTORALL

THE NEEDLE DOES THE JOB!

## TUNER CLEANER with INJECTOR NEEDLE

**NEW!**  
Wax-Free lubricant added, keeps tuners and controls cleaned longer.

The Injector Needle cleans and lubricates where you need it...  
You can reach hard-to-get at wafers without pulling tuners apart or even removing chassis from cabinet. DON'T WASTE PRECIOUS CHEMICALS! YOU NEVER SPRAY AIR!

**INJECTORALL CO.**  
2081 Shore Parkway Brooklyn 14, New York

# ATLAS

**\$129.95**  
DEALER NET

- ★ **LOWEST PRICE** quality tube tester on the market
- ★ **GUARANTEED**, non-obsolete, patented memory bank instantly adapts ATLAS to test any new tube
- ★ **MOST BEAUTIFUL** looking addition to any store

**SIMPLEST BY FAR TO OPERATE**  
**PROVEN - TROUBLE FREE**  
**SAFE - NO HIGH VOLTAGE ON PANEL**

See your local distributor for further information—write

**AFFILIATED television laboratories, inc.**  
112-07 FRANCIS LEWIS BLVD., QUEENS VILLAGE 29, N. Y.  
HOllis 3-8000

**SMALL  
ENOUGH TO FIT  
INTO THE  
SMALLEST  
POCKET PORTABLE**

40K

**WITH ENOUGH  
POWER FOR THE  
BIGGEST  
COLOR TELEVISION  
RECEIVER**

**Tarzian**

(SERIES)

## Silicon Rectifiers

- ✓ **COMPACT**—no special holder required . . . supported by pigtail leads
- ✓ **PROVED-PERFORMANCE**—in all electronic applications
- ✓ **ECONOMICAL**—Tarzian's mass production means lower cost to you
- ✓ **PACKAGED** for your convenience in pocket-size "5 Paks".



Send for data sheets.

### SPECIFICATIONS

	40K	K-200
MAX. AC INPUT VOLTAGE	130	130
MAX. PEAK INVERSE VOLTAGE	400	360
MAX. PEAK CURRENT (MA)	7500	2000
MAX. DC CURRENT (MA)	750	200
APPROX. RECTIFIER VOLTAGE DROP	2	2
MAX. OPERATING TEMP.	100°C	100°C
MAX. SURGE CURRENT (AMPS)	30	20
MIN. SURGE LIMITING RESIS. (OHMS)	7.5	10

### DIMENSIONS

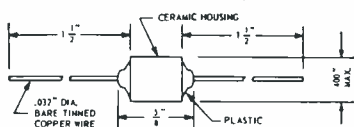

**Sarkes Tarzian, Inc.**

DEPT. PF-3

RECTIFIER DIVISION, 415 N. COLLEGE AVE.  
BLOOMINGTON, INDIANA

IN CANADA: 700 WESTON RD., TORONTO 9, TEL. ROGERS 2-7535  
EXPORT: AD AURIEMA, INC., NEW YORK CITY

## Let's Talk Business

(Continued from page 34)

audio cans and found that this varied the volume. Both cans had shorted turns. The insulation on the windings had deteriorated, and by shaking the cans the extent of the shorts within windings would change, thereby shifting the alignment of the tuned circuits. By constant retrimming, the audio could be peaked, but never to its original level. I knew two new cans and a good audio alignment would restore performance.

First, I told the customer, "You need two new audio transformers and an audio alignment."

The customer said, "Now tell me in English what that means."

I smiled and added up the figures in my head, and then continued in terms he could understand. "Your set needs shop work. It will take two to three days and the bill will run you between twenty-two and thirty dollars."

"How do you figure that?" he asked.

I answered, "This sound job is going to run about \$17.50. That will include pickup, delivery, cleaning, adjusting and the first hour's labor on the bench, which is usually all that is necessary. Then you'll need two transformers which will run about five dollars. I'm leaving myself open for a few dollars in case you need a tube or two or three."

I got the job, but you may be wondering, "Don't you sometimes lose jobs by being so candid?" Sure, we lose a few, but not as many as you might expect. Also, the reduction in aggravation and the additional good will that always occurs when people know they can count on your word make the system well worthwhile.

This particular job ran just about as expected. After the two cans had been replaced, it was found that two 6AU6 tubes were needed. The bill ran about \$27, which was under the top quote of thirty, and the customer is still very much ours.

### Estimating an Unknown Trouble

Estimating an unknown trouble is a little more ticklish, but it can still be handled in a similar manner with just a couple of important changes.

Another Sencore Time-Saver

# NEW

## IMPROVED SENCORE

### LC3 Leakage Checker

Check these outstanding New Features

**Now — For the first time . . .**

Checks 144 different tube types — more than any other "grid circuit" type checker. Includes UHF and latest type tubes.

Checks picture tubes without removing tube from cabinet or chassis.

New Roll Chart prevents obsolescence — just dial the tube type and save time. Chart is easily replaced at no extra cost.

Dynamic Filament checks including heater to cathode leakage & shorts — no need for a second filament tester.

Two spare preheating sockets to cut down testing time.

Capacitor checks simplified.

The LC3 provides all these new improved features in addition to those included in earlier leakage or "grid circuit" testers. A must for any TV service technician.

\$28.95

DEALER NET  
Really Whips Tough Dogs

**SERVICE**

**INSTRUMENTS CORP.**

171 Official Rd • Addison, Ill.

In stock at your local parts distributor

Cut out this ad now for further information

WORKMAN TV INC.

## The BELIMITER

USED IN RCA TV SETS FOR PROTECTION OF DEFLECTION CIRCUITS

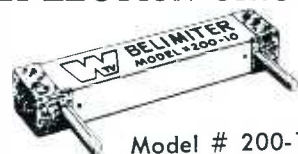

Model # 200-10

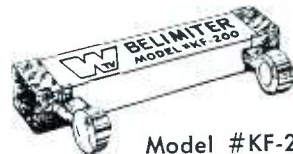

Model # KF-200

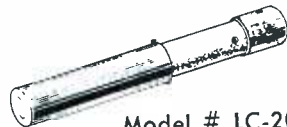

Model # LC-200

AVAILABLE AT YOUR LOCAL PARTS JOBBER  
ASK FOR BULLETIN #SB1

**WORKMAN TV INC.**  
TEANECK, N. J.



For example, consider a 16" Admiral shop job I ran into. After some interrogation of the set owner, I finally deduced that the complaint was intermittent horizontal sync. I began turning the TV off and on, and with some effort, eventually was able to cause the picture to break into horizontal stripes.

I trimmed up the horizontal frequency adjustment in the rear and the picture popped in. After a while I had the symptoms down pat. There was a horizontal instability that occurred after turning the TV off and on. It could be cleared temporarily by adjustments. Tubes didn't affect anything so I decided to pull.

The customer said, "It can't be very much because it almost works right."

I explained, "Sometimes a trouble like this is the hardest to fix. I'm going to have to take it into the shop."

She went through the usual question of why. I explained the usual answers of it's a subtle trouble, needs special test equipment to consummate the job, etc.

Then she asked, "How much is it going to cost and when will you return it?"

I said, "Let me figure the estimate." I went out to the truck and brought in my CRT tester. The picture tube tested good. I examined the tuner; it was a little dirty, but otherwise in good shape. I figured with my fingers crossed; it's probably a small component, but the absolute worst it could be is the fly-back. I said, "It will take about two or three days. The price can't be any less than eighteen and won't be any more than thirty."

She said, "Suppose it is more than thirty?"

I answered, "If it is, I'll stop the repair and call you before going ahead. Thirty is the ceiling."

Sure, I was going out on a limb. But the limb is not as spindly as you'd think. I have my years of experience to back me up on estimates. I checked the CRT and tuner before estimating, and believe it or not, I haven't made too many serious mistakes yet. You won't either if you use your head.

On the bench I began examining voltages. Everything read right on the button. I measured components in the horizontal oscillator circuit.

*For my Money*  
**XCELITE Tools are**  
*the Finest!*

... Superbly made and designed for Radio, T.V. and Electronic Technicians. *See your Distributor* ... only one quality ... the finest — whether you choose individual items or the handy kits ...

*Use the Tools the Professionals use!*

**XCELITE, INCORPORATED**  
ORCHARD PARK, NEW YORK  
Canada: Charles W. Pointon, Ltd., Toronto

**XCELITE**  
*Quality Hand Tools*  
PREFERRED BY THE EXPERTS

**MAKE YOUR STANDARD TEST PRODS**  
**TEN TIMES**  
**MORE EFFECTIVE IN SECONDS**  
**WITH THE E-Z-HOOK TIP**  
CONVERTS YOUR STANDARD TEST PROD TO A SELF-HOLDING CONNECTOR  
**SLIPS EASILY ON OR OFF!**

Easy to use

**Here are the TEN E-Z-Hook Tip advantages:**

1. Easy to attach — slips easily over test prod tip.
2. Stays on — special chuck holds tip firmly on prod.
3. Easy to connect or disconnect — patented design operates with light forward pressure.
4. Safer checks — hands stay clear of wiring.
5. Won't slip off — exclusive hook design clamps firmly around conductor.
6. Eliminates intermittents — spring pressure insures positive contact.
7. Eliminates adjacent shorts — insulated design gives maximum protection.
8. Connects anywhere — fits large or irregular shaped conductors.
9. Frees your hands — holds test prod for you.
10. Makes testing easier — saves time — eliminates aggravation.

No. 54-1 E-Z-HOOK Tip Only 89c ea.

**E-Z-HOOK TEST PRODUCTS**  
ORDER THROUGH YOUR PARTS DISTRIBUTOR  
E-Z-HOOK TEST PRODUCTS  
Dept. #2, 1536 Woodburn Ave.  
Covington, Ky.

Canadian Rep.: Len Finkler & Co., Toronto, Ontario

repairing TV sets?  
for the right part to do  
the best job

you'll find it  
faster in the  
**MASTER**

new 1958 edition — world's largest electronic catalog only \$3.50 at your local parts distributor — now Free! Write for Panel Lamp Chart.

THE RADIO-ELECTRONIC MASTER  
60 MADISON AVE., HEMPSTEAD, N. Y.

# FREE!

all-steel file cabinets  
with your purchase of  
**PHOTOFACT**  
the world's finest TV-Radio Service Data



**FREE** FOR REGULAR  
PHOTOFACT SUBSCRIBERS

You get these valuable File Cabinets ABSOLUTELY FREE from Howard W. Sams if you are a regular subscriber to PHOTOFACT and buy each Set as issued monthly...

**FREE** FOR PHOTOFACT  
LIBRARY PURCHASERS

You get FREE File Cabinets as you complete your profit-building PHOTOFACT Library... What's more, you can own the PHOTOFACT Library the new Easy-Buy way. Here's how...

**NEW EASY-BUY PLAN**

No interest. No carrying charge. As little as \$10 down. Up to 24 months to pay. And Howard W. Sams will give you absolutely free all the steel file cabinets you'll need for your Library: Single-Drawer File Cabinet worth \$8.95 with your purchase of 60 Sets of PHOTOFACT Folders; Two single-drawer File Cabinets worth \$17.90 with your purchase of 120 Sets; Three single-drawer File Cabinets worth \$26.85 with your purchase of 180 Sets; Four single-drawer File Cabinets worth \$35.80 with your purchase of 240 Sets.

Take advantage of this money-saving opportunity. See your Sams Distributor today, or write to Howard W. Sams...

**GET THE FULL DETAILS**

**HOWARD W. SAMS & CO., INC.**  
2201 E. 48th St., Indianapolis 5, Indiana

Send me full details on your FREE File Cabinet offer and EASY-BUY Plan.

I'm a Service Technician:  full time;  part time

My Distributor is: .....

Shop Name: .....

Attn.: .....

Address: .....

City: ..... Zone: ..... State: .....

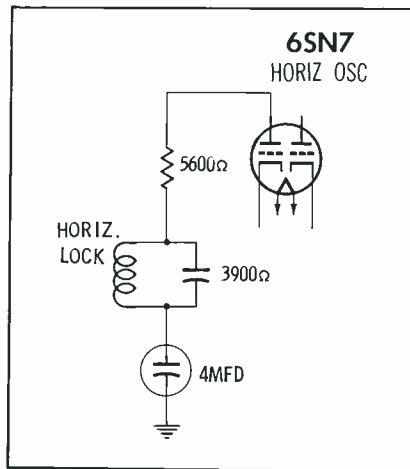

Fig. 2. An open 4-mfd filter capacitor was causing unstable horizontal sync.

All seemed to check OK until I got to a 4-mfd electrolytic. It read open. I replaced the filter and the sync trouble ceased. After replacing a couple of weak tubes, the bill ran about \$24. I was well within my estimate and the customer was happy with the repair from start to finish.

### If a Mistake is Made

No doubt you are saying, that's all well and good, but suppose you're way off on the estimate. TV receivers are strange animals, and no matter how carefully you plan, or how hard you try, you're bound to get fouled up sometime or another.

A case in point involved a call on a 27" Zenith. I gave the call to an outside tech. He called the customer and said, "I'll be there in an hour." In exactly an hour, he was there.

He examined the set, an old baby, and found loss of sync and frequency response. The usual house checks did no good, so he decided to pull the chassis. He promised the customer delivery in four days and gave her a price range between twenty and thirty dollars.

On the bench, a component check in the video circuits revealed that the germanium diode had a low resistance reading in both directions. With a new unit in the circuit, the picture came in fair and sync was restored. A complete IF alignment changed performance from fair to gorgeous. The set was air-checked for four hours and declared ready for delivery by the fourth day.

On the fourth day, the customer was alerted for delivery and informed that her bill ran midway in the

**WILL YOUR REPLACEMENT Fuse Resistor BURN OUT AGAIN?**  
Not if you use —  
**The NEW SENCORE "FUSE-SAFE" CIRCUIT TESTER**

Another Sencore Time-Saver

Save costly call backs by testing the circuit before replacing fuse, fuse resistor or circuit breaker.



Individual scale for each value fuse resistor — no interpretation, just read in red or green area.  
★ Measures line current and up to 1100 watts of power at 115 volts using line cord and socket.  
★ Two convenient current ranges — 0 to 2 amps and 0 to 10 amps. Test leads clip in place of fuse or fuse resistor.  
★ 5 ohm, 10 watt resistor prevents TV circuit damage and simulates operating conditions.

As Recommended by Leading Manufacturers

Mfg by **SENCORE SERVICE**  
INSTRUMENTS CORP.  
71 OFFICIAL RD., ADDISON, ILL.

Cut out this ad now for further information



**\$8.95** DEALER NET  
MODEL FS-3  
AC-DC or both as needed for Fuse Resistor Circuits

**THE SERVICEMEN PREFER B & M**

Have You Ever Wished You Could:

— See both the input and output patterns of a vertical sync at one time?

OR:

— Compare frequencies in the phase detector and horizontal circuits with both patterns at once?

You can, you know... With the

**B & M Model ES-40 ELECTRONIC SWITCH**



### FEATURES:

- Switching Rates 400-4000-20,000 Cycles
- Channel One Amplifier has Gain of 30DB
- Channel Two Amplifier has Gain of 10DB
- Frequency response of both Amplifiers 20 to 100,000 cycles with No Drop in Amplitude.
- Calibrating voltage, either channel 18 volts Peak to Peak

HO40 15,750 Oscillator to plug into above unit... will work on either channel

Price \$69.95

Price \$19.95

**B & M Electronic Mfg. Co.**  
2516 Dodge Ave. Fort Wayne, Indiana

LET US HELP YOU TO GREATER PROFITS

BY THE USE OF

— B & M INSTRUMENTS —



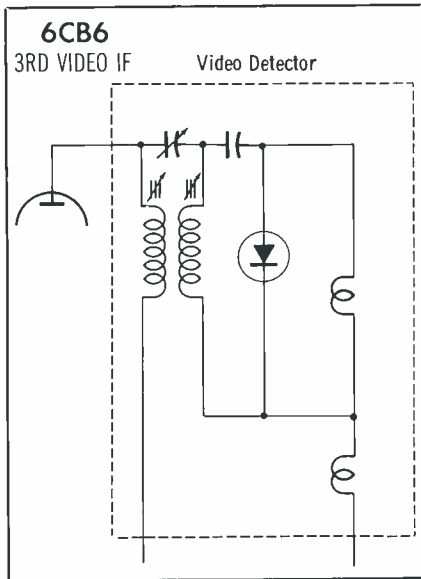

Fig. 3. The defective germanium diode caused an AGC-type trouble symptom.

estimate range. She was pleased. The tech took the chassis over and installed it. The picture came in beautifully for a moment—then it began rolling vertically. The tech was flabbergasted to say the least. The customer was even more flabbergasted. Our man examined it thoroughly and found he had to pull again. He took a deep breath and began to explain.

The customer listened and then said, "You people have kept your word to the letter up till now. I have no reason to believe anything but the fact that this is unavoidable. You stop worrying and do what is necessary."

The tech brought the chassis back in. I located a 6U8 socket which was shorting to ground and repaired it pronto. She had the TV back in two hours. I didn't put any extra charge on the bill, so she gave the serviceman a \$2.00 tip.

Can you imagine what the situation would have been if we had kept the chassis four days without telling her originally it would take that long. She optimistically would have expected it done overnight. And suppose we had charged \$25.00 without originally giving any indication of price. Surely she would have hoped, and therefore believed, it was only going to be \$8.00 or \$10.00.

Good faith shows through, and I've found with few exceptions that everything runs smoothly when there is strong evidence of good faith between customer and technician. ▲

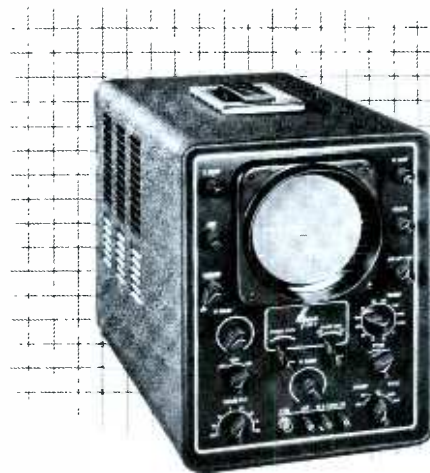

**Hycon** MODEL 622A  
**PROFESSIONAL**  
**5" OSCILLOSCOPE**  
*for color tv*  
*and pulse work*

A wide-band (to 6 mc) 'scope with high vertical sensitivity and low internal noise, equipped with triggered or recurrent sweeps and preset TV sweep frequencies.

5X expansion of horizontal, plus real sync stability, means you can examine a 6 mc sine wave using a direct probe.

Full details in Bulletin 622A

At your distributor

Model 622A..... \$426.00



**Hycon** MODEL 616  
**Color Bar/Dot Generator**  
 The complete color signal test instrument, and companion unit to Model 622A

At your distributor... \$485

**Hycon**  
 ELECTRONICS, INC.  
 A SUBSIDIARY OF HYCON MFG. CO.  
 370 South Fair Oaks, Pasadena, California

## CADDY TUBE TESTER

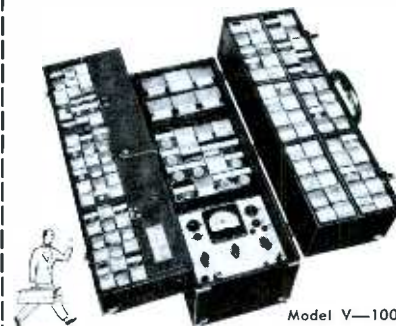

**FOR RADIO-TV SERVICE CALLS**

Here's the fastest, most reliable tube checker ever designed — *built right into an excellent, large-capacity caddy!* You can check an entire set of tubes for radio or TV in minutes, replace the faulty ones immediately and be on your profitable way. Checks picture tubes, selenium rectifiers, more than 500 receiving tubes. Only \$99.50 dealer net.

See your supplier or write for details.

**VIS-U-ALL** products company  
 303 Fuller N.E., Grand Rapids, Mich.

## Ge TRANSISTOR Z5 SILICONE COMPOUND

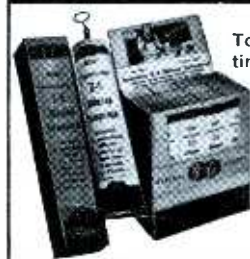

To be used every time a transistor is replaced; maintains efficient heat transfer from transistor to chassis. 1 oz. tube.  
 No. 8101...List \$2.25

## G-C ELECTRONIC OIL ASSORTMENT KIT

Contains every commonly used special purpose oil used in electronic servicing. Six oils in handy vial dispensers.  
 No. 9400.....List \$3.50



FREE CATALOG... WRITE TODAY!

## GENERAL CEMENT MFG. CO.

division of TEXTRON INC.  
 Western Plant: Los Angeles 18, Calif.  
 Main Plant: ROCKFORD, ILLINOIS, U.S.A.

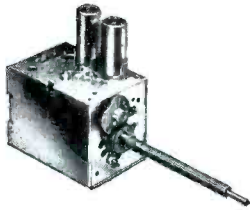

**Now YOU can get  
TUNERS  
repaired, or replaced,  
in a hurry!  
Send them to TARZIAN!**

● Sarkes Tarzian, Inc., announces a new tuner repair service and factory replacement program for Tarzian-manufactured tuners. Distributors, dealers and servicemen will welcome this direct factory service program which is designed to take delay and confusion out of the tuner repair business.

We're set up to offer a 48 hour service from the date of receipt to shipment to you.

Cost is reasonable, too. Only \$7.50 per unit (\$15 for UV combinations) and that includes ALL replacement parts! Both repaired — or exchange units if available from stock — carry a 90 day warranty against defective workmanship and part failure.

Replacements will be offered at these current prices\* on units not repairable:

- VHF 12 position tuner . . . \$17.50
- VHF 13 or 16 position tuner . . . . . 19.50
- VHF/UHF combination . . . 25.00
- UHF only . . . . . 15.50

\*Subject to change

When inquiring about tuner service, always refer to tuner by part number. When inquiring about direct replacements for tuners other than Sarkes Tarzian-manufactured, please indicate tube complement, shaft length, filament voltage, series or shunt heater. Use this address for quickest service:

**SARKES TARZIAN, Inc.**

Att: Service Mgr., Tuner Division  
East Hillside Drive  
Bloomington, Indiana



TARZIAN Electronic Product and Services include TELEVISION TUNERS . . . SELENIUM AND SILICON RECTIFIERS . . . BROADCAST EQUIPMENT . . . AIR TRIMMERS . . . TV STATIONS WTTV and WPTA, and RADIO STATION WTT5.

**Record Changers** (Continued from page 27)

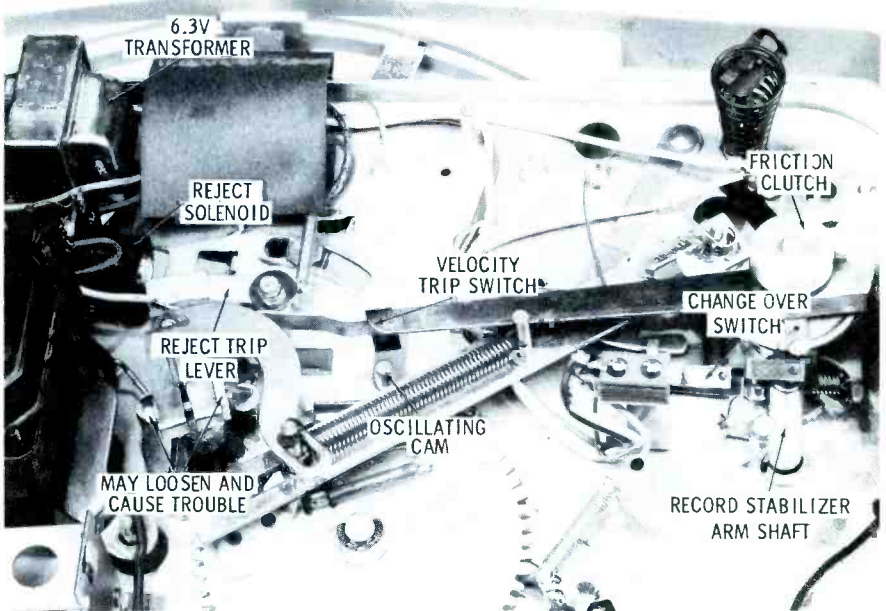

Fig. 11. Underside of Zenith S-14086 record changer with key points identified.

damage to the spindle, the adapter, or both.

No tracking-force adjustment is provided, as the tone arm is balanced for use with the Zenith *Cobra* cartridge. The height and set-down adjustments are located beneath the rear of the tone arm and require the use of a Phillips screwdriver as illustrated in Fig. 10. The set-down adjustment is made as follows: Place a 10" record on the turntable, leaving the stabilizer in its uppermost

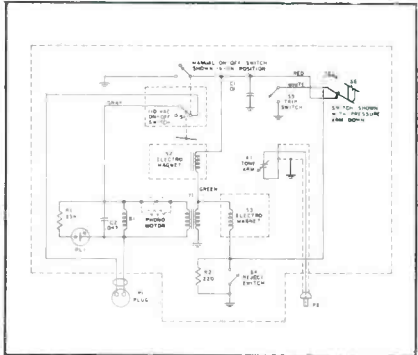

Fig. 12. Schematic of Zenith changer.

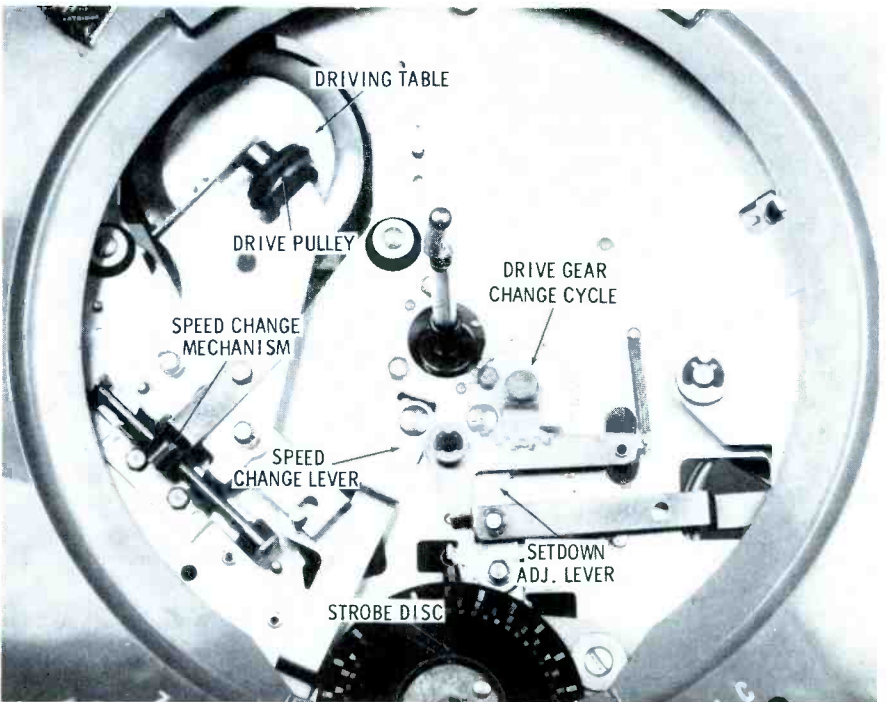

Fig. 13. View of Zenith record changer with turntable removed shows motor-drive, electronic stroboscope, and other mechanisms incorporated in the unit.



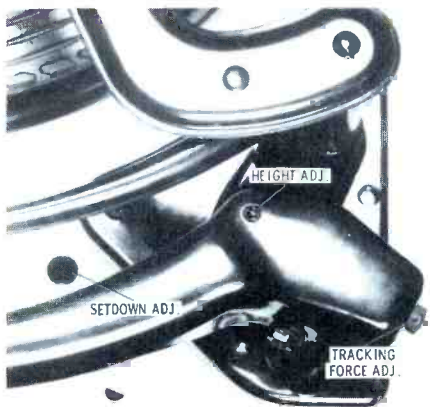

Fig. 14. Set-down, height and tracking-force adjustments on Garrard RC 121/4.

and outermost position and setting the index selector to the 10" position. Trip the reject trip lever (Fig. 11) and cycle the changer by hand until the needle starts its downward travel. The Phillips-head screw (Fig. 10) can now be adjusted to position the needle over the center of the lead-in band at the outer edge of the record.

The height adjustment (Fig. 10) must be set so that the tone arm will clear a full stack of 12 unwarped records resting on the turntable and still not strike a record resting on the spindle shelf. This adjustment can also be checked by cycling the changer by hand.

Referring to Fig. 11, the velocity-tripping mechanism for this Zenith model consists of a friction clutch on the tone-arm assembly, electrical trip contacts, an oscillating cam, and a set of changeover contacts. The friction clutch causes the movable arm of the trip switch to move inward as the tone arm tracks toward the spindle. The oscillating cam prevents the trip contacts from making

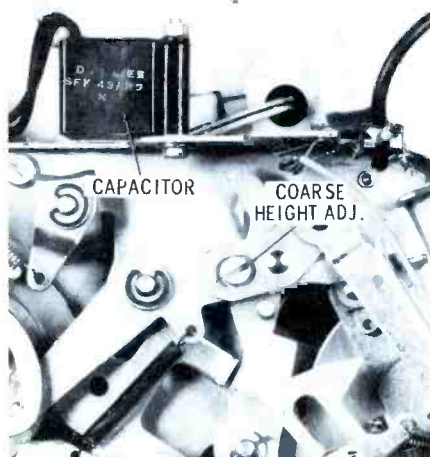

Fig. 15. Coarse height eccentric may be used with height adjustment on arm.

# Here's How You Can Make MORE PROFIT on TV Repairs

## PAYS FOR ITSELF IN A VERY SHORT TIME

- The new Tel-A-Turn service cradle increases efficiency and output of any Electronic Technician.
- Simplifies part replacement, soldering, test probing.
- Prevents breakage and damage to above-chassis components.
- Ideal portable bench for "on-the-spot" work.
- A self-locking worm and gear provides 360° chassis rotation for the most convenient position for servicing above or below-chassis components.
- Quick-operating clamps hold chassis from 9" to 25" wide, and up to 200 pounds.
- Adjustable swivel lamp permits placing light for best visibility.
- A built-in PM speaker eliminates removing speaker from TV cabinet.
- Two hot outlets are provided for soldering iron and test equipment.
- Cheater cord, switch and pilot light provide safe, easy means of supplying and cutting off power to chassis under test.
- Tel-A-Turn is mounted on ball bearing casters for smooth, easy mobility.
- Made of heavily ribbed cast aluminum. Weighs only 37 pounds.

"Here-at-Last", a practical service cradle for servicing Radio and TV chassis, Record Changers, Amplifiers and other Electronic Equipment. No service tool is more useful or profitable. Write Dept. PF-98 today for descriptive literature. Dealer inquiries invited.

# ROGERS MANUFACTURING CO.

LINDSEY, OHIO-U.S.A.

**CAN YOU READ THIS MESSAGE?**

The Oscilloscope is a wonderful instrument—if you can understand it. These unusual patterns are only a few of the hundreds and hundreds illustrated and explained in this new Gernsback Library Book, "Oscilloscope Techniques" by Alfred Haas. It shows you how to understand waveforms, master scope operation, and put it to new uses.

**OSCILLOSCOPE TECHNIQUES**  
 Deluxe hard cover edition 224 pages, Hundreds of waveform photos, List price, \$4.60

**HOW TO GET THIS BOOK FOR ONLY \$3.35!**  
 Through the G/L Technicians' Book Club you can get this book and others equally valuable for only \$3.35—a 27% saving!

**HOW TO JOIN**

- Fill in this coupon.
- SEND NO MONEY—we send you the book on approval.
- If you like it, send your remittance, if not, return book.
- You receive a new book every four months on the NO-RISK approval plan.
- You need take only four books during entire membership period. No time limit.
- You may cancel any time after that.

**NO-RISK COUPON**

Gernsback Library, Inc. PR-98  
 154 W. 14th St., New York 11, N. Y.

Enroll me in the G/L Technicians' Book Club. Send me my copy of OSCILLOSCOPE TECHNIQUES

Send me more information on the G/L Technicians Book Club

Name ..... please print

Street.....

City..... Zone..... State.....



Fig. 16. Velocity-trip adjustment is beneath turntable for Garrard unit.

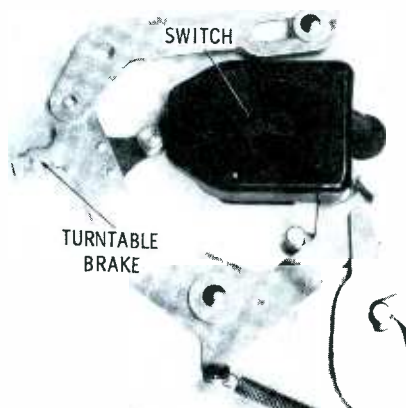

Fig. 17. Brake operates in conjunction with on-off switch to stop turntable.

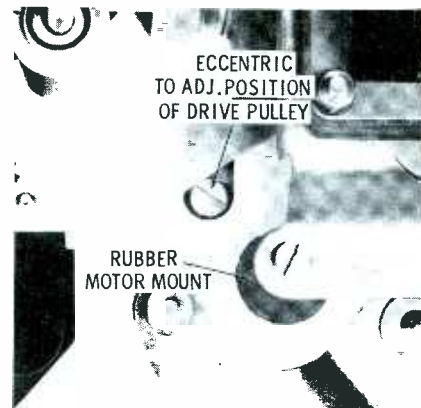
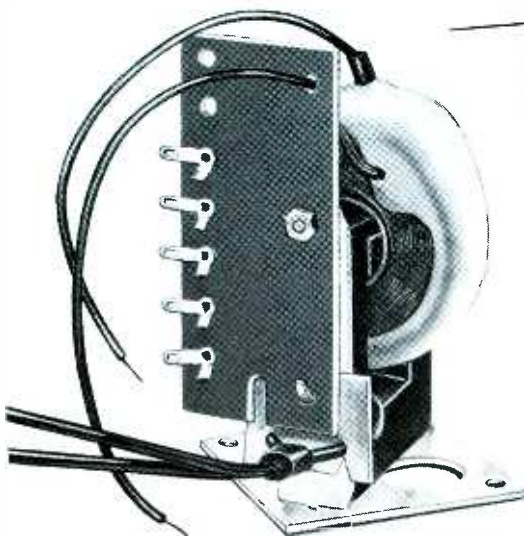

Fig. 18. Drive-pulley tension adjustment is accessible from underside of changer.



**here is PROOF!**

This table of STANCOR'S exact replacement flyback coverage is based on an actual count of the models listed in the latest STANCOR TV Replacement Guide. *Only exact replacement flybacks are listed.* These percentages do not include flybacks that require chassis or circuit alteration. Actually, true coverage is even higher than these figures indicate since STANCOR covers *all* of the most heavily produced models.



Manufacturer	Stancor EXACT Repl. Flybacks	COVERAGE
Admiral	9	83%
Airline	11	81%
General Electric	14	95%
Olympic	4	83%
Philco	12	90%
RCA	11	91%
Silvertone	11	74%
Zenith	14	97%



Write now for your free copy of the latest TV Transformer Replacement Guide, listing over 17,000 TV models and chassis.

**CHICAGO STANDARD TRANSFORMER CORPORATION**

3503 ADDISON STREET • CHICAGO 18, ILLINOIS

while the innermost grooves are tracked. Rapid motion of the tone arm in the lead-out groove permits the movable arm to escape the oscillating cam and close the trip contacts to start the change cycle. When the last record drops on the turntable, the stabilizer bar drops and actuates the change-over switch. The trip switch will then shut the changer off at the end of the last record and the tone arm will remain at the center of the record.

The bolt and nut in the record-dropping mechanism (Fig. 11) can loosen and cause erratic record dropping. Another possible source of trouble is the reject solenoid and its accompanying transformer. A study of the complete electrical diagram (Fig. 12) will help you to understand the operation of the trip and reject cycle.

The motor drive, electronic stroboscope, and other mechanisms located beneath the turntable are revealed in Fig. 13. The motor-drive assembly is somewhat unusual in that it consists of a belt-driven drive table and a vertical roller which transmits power between the drive table and the underside of the turntable. Speed change is accomplished by moving the vertical drive wheel; the fastest speed will be obtained near the center of the drive table, and the slowest near the outer edge. Speed change on this unit is continuously variable, and a stroboscope is included to permit precise speed adjustment. Generally speaking, the electrical contacts, solenoids, record-dropping mechanism, and friction clutch in the trip assembly are the most likely trouble spots in this particular changer. Another thing—the changer must be level to operate normally.



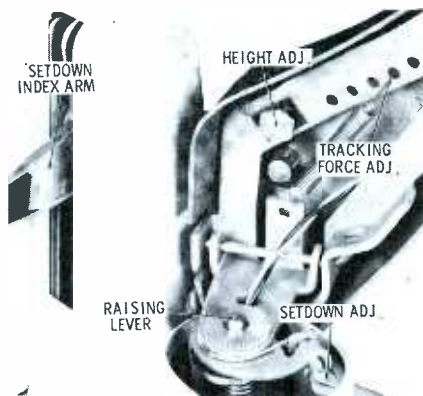

Fig. 19. Height, set-down and tracking-force adjustments on Monarch UA-8.

### Garrard RC 121/4

Although this changer has a profusion of moving parts and mechanical linkages, only a minimum number of adjustments need be made. The customary set-down, height, and tracking-force adjustments (Fig. 14) are associated with the tone arm. The set-down adjustment is factory set for optimum accuracy; however, minor changes can be made by turning the eccentric screw which is accessible through a hole in the main plate when the tone arm is at rest.

The height adjustment should be set so that the needle will clear a stack of eight 12" records resting on the turntable. Further, the stylus should clear the top record surface by  $\frac{1}{8}$ " during the change cycle. If more change is required than can be obtained with the height adjustment on top of the tone arm, the coarse adjustment (Fig. 15) can be turned slightly to extend the range. After turning the coarse height eccentric, the tone-arm height adjustment must be reset for optimum accuracy.

Tracking force is adjustable via the knurled screw on the rear of the tone arm. It is recommended that

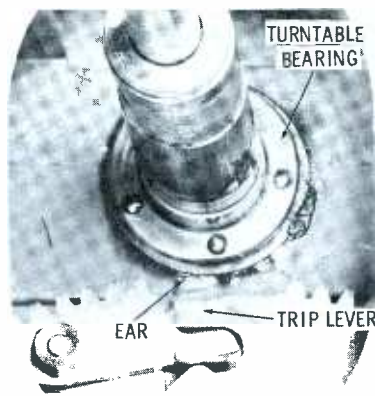

Fig. 20. Bend ear on trip lever if it fails to engage lobe on turntable shaft.



Fig. 21. Reset ridge returns trip lever to position after trip cycle has started.

## NEW from *South River*

### NOW MAKE IT EASY FOR YOURSELF



With SOUTH RIVER'S  
NEW Antenna Mountings  
designed for faster, easier  
television antenna  
installations!

THE MOST CONVENIENT ROOF TOP MOUNTING AVAILABLE.  
CHECK THESE TIME AND MONEY SAVING FEATURES.

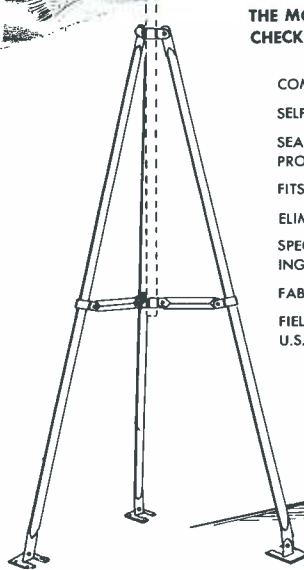

- COMPLETELY PRE-ASSEMBLED.
- SELF SUPPORTING AT ALL TIMES DURING INSTALLATION.
- SEALING COMPOUND PERMANENTLY AFFIXED TO ADJUSTABLE FEET TO PROVIDE A POSITIVE, LEAK-PROOF INSTALLATION.
- FITS ALL PEAK OR FLAT ROOFS.
- ELIMINATES GUY WIRES, TURNBUCKLES, ROOF HOOKS & GUY CLAMPS.
- SPECIAL, HARDENED, SCREW NAILS INSURES STRONG, RIGID FASTENING TO ROOF.
- FABRICATED OF HOT DIP GALVANIZED STEEL TUBING.
- FIELD TESTED BY THOUSANDS OF INSTALLATIONS THROUGHOUT THE U.S. FOR OVER FIVE YEARS.

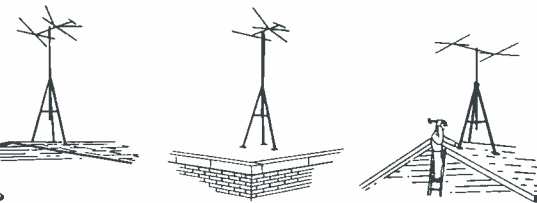

SAVE LABOR COST ON EACH ROOF INSTALLATION! NO ADDITIONAL MAN NEEDED ON ROOF!!  
AVAILABLE IN TWO SIZES. MODEL BT-5 USED WITH A 1 1/4" O.D. X 5' MAST MAKES A 7 FOOT INSTALLATION.  
MODEL BT-10 WHEN USED WITH A 1 1/2" O.D. X 5' MAST MAKES A 9 FOOT INSTALLATION AND WHEN USED WITH A 10 FOOT MAST MAKES A 13 FOOT INSTALLATION.

MODEL No.	DESCRIPTION	LIST PRICE
BT-5	Bantam Tower (less mast)	\$7.25
BT-10	Bantam Tower (less mast)	\$9.95



*South River* SOUTH RIVER, NEW JERSEY  
METAL PRODUCTS CO., INC.  
PIONEER AND OUTSTANDING PRODUCER OF THE FINEST LINE OF ANTENNA MOUNTINGS

Write for Complete Catalog

CANADA: LEN FINKLER & CO., TORONTO



An  
exclusive  
service  
by

**Amperex®**  
distributors:

## VALVO RECEIVING TUBES

for replacement in  
European radios

Many European radios and hi-fi components now popular in this country utilize the European-made VALVO tubes, which have thus far had no American distribution. As a special service to the trade, VALVO tubes are now being stocked by all franchised Amperex distributors. Replacement of the original tubes with completely identical types will assure optimum results in the repair and servicing of these European sets.



ask **Amperex**  
for the name and address  
of your nearest distributor

**Amperex Electronic Corp.**  
230 Duffy Avenue Hicksville, L. I., N. Y.

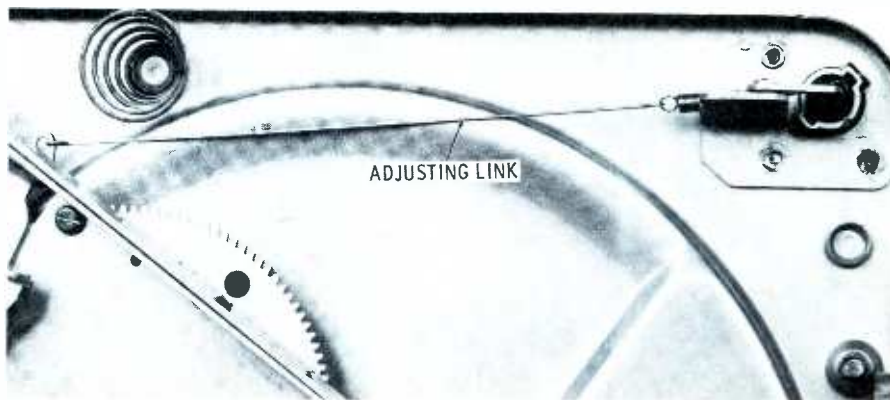

Fig. 22. If changer fails to shut off after last record, bend link to shorten.

the weight correspond to the specifications outlined by the cartridge manufacturer, but should not exceed 10 grams for LP records. Turning the knurled screw clockwise reduces the weight.

The automatic trip mechanism is of the velocity-tripping type and is set to commence operation when the stylus reaches the  $2\frac{3}{4}$ " diameter point on a record. If the trip fails to operate (the pickup remains running in the center of the record), turn the auto-trip adjustment (Fig. 16) about one-half turn clockwise. This raises the automatic trip lever and enables it to engage the cam on the striker when the stylus runs into the record run-off groove.

The on-off switch is located beneath the turntable (Fig. 17) and works in conjunction with a brake assembly. When the changer switches to the off position, the felt pad is forced against the turntable to bring it to a stop. The felt pad is replaceable; however, the old pad can be

reseated in its holder should it become worn. So, it won't be necessary to replace the pad until it becomes so worn that further reseating is impossible.

The drive-wheel tensioning adjustment shown in Fig. 18 permits the drive wheel to be held against the turntable edge with exactly the force required for slip-free operation. Should the drive wheel slip and fail to drive the turntable nor-



Fig. 23. Rubber bumper on tone arm.

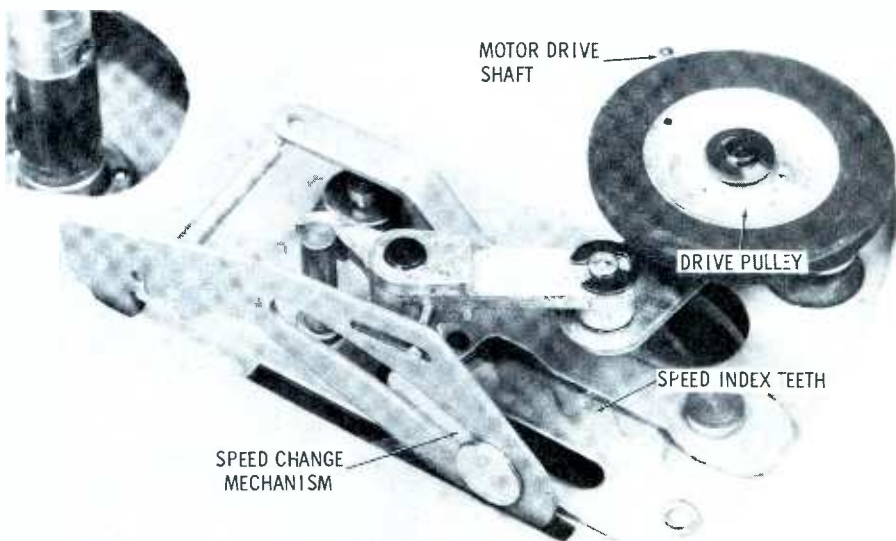
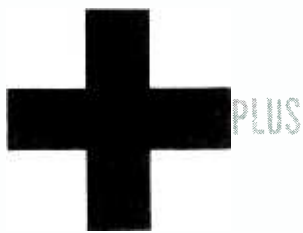

Fig. 24. Teeth in speed-index assembly provide positive drive-speed changes.



**all new edition**

VOL. III, NO. 1



**up-to-date  
component  
prices**

**the quick  
easy way  
to figure  
service charges**

*Dave Rice's*

## OFFICIAL PRICING DIGEST



Flat rate and hourly service charges, based on and showing regional and national averages, plus up-to-date list or resale prices on over 63,000 components. Arranged alphabetically by manufacturers and products, numerically by part number. Compact, convenient size fits in tube caddy, toolbox or pocket. \$2.50 per copy from your distributor.

**ELECTRONIC PUBLISHING COMPANY, INC.**  
180 N. WACKER DRIVE, CHICAGO 6, ILL.

## RADIO AND TV SERVICEMEN

New VTVM Offers More  
Features . . . Cuts Servicing Time



**SECO**  
Model 208  
VTVM

Look at all these great new features—  
write for detailed specifications!

A "foolproof" VTVM with a large, easy-to-read 4½" meter on a sloping panel. Provides 7 AC, 7 DC, 7 ordinary ranges—plus special RETMA (EIA) Ohm scale to check standard resistors and tolerance limits. Operates on 105-125 V. 50-1200 cycles—can be supplied for operation on 220 V. 50-1200 cycle current. Unit has independent line voltage check. Incorporates specially designed "shift-lever" type function switch with most commonly used functions located at "can't miss" positions. Color coded switch identifies and automatically connects proper probe. Separate jack for HV probe. Meter is shunted by ON-OFF switch when unit is carried. Portable, easy to use—complete with stand, 40' leads with slim probes, and common lead with clip.

**\$7450**  
NET

Genuine leather, felt-lined carrying case for Model 208. . . . \$9.95 NET

See your distributor for complete information or write to:



**SECO MANUFACTURING CO.**  
5015 Penn Ave. So., Mpls., Minn.

mally, the adjustment can be set to increase friction. The adjustment should be no tighter than required for slip-free operation.

### Monarch UA-8

The Monarch UA-8 changer made by Birmingham Sound Reproducers Ltd. of England is being used in a number of packaged hi-fi units and mass market phonographs.

The conventional adjustments associated with the tone arm are pointed out in Fig. 19. Set-down should be adjusted by cycling the changer by hand until the pickup starts its downward travel, and then turning the set-down screw to center the stylus over the lead-in band at the edge of the record. To key the needle set-down position to the record size, a record should be placed on the shelf and steadied with the stabilizer bar. Subsequent operation of the changer through cycle will cause the record to drop, setting the index arm to correspond to record size.

The height adjustment (Fig. 19) should be set so that the needle will clear a stack of 10 records on the turntable by 1/16" during the change cycle. In this position, the arm will also clear any records resting on the spindle shelf. The tracking force is adjustable by moving the tensioning spring into one of the five holes in the underside of the tone arm (Fig. 19). Correct tracking force is on the order of 8 to 10 grams for microgroove records.

The velocity-tripping mechanism has no adjustment; however, the ear on the trip lever (Fig. 20) can be bent toward the spindle if it fails to engage with the lobe on the turntable center-shaft assembly to start the change cycle. The trip lever is not spring-loaded and is therefore returned to its original position by a positive mechanical action when it strikes the reset ridge shown in Fig. 21.

If the changer fails to shut off after the last record plays, either the on-off microswitch is defective, or the adjusting link (Fig. 22) is too long. If the microswitch has been checked and eliminated as the source of the trouble, the adjusting link may be shortened slightly by making a bend or kink somewhere along its length. Should the pickup

the specs are the proof . . .  
the BEST BUYS are **EICO**<sup>®</sup>  
for COLOR & Monochrome TV servicing



**COLOR**

and Monochrome  
dc to 5 mc lab & tv  
5" OSCILLOSCOPE

= 460  
Factory-wired **\$129<sup>50</sup>**  
Kit **\$79<sup>95</sup>**

#### • Features DC Amplifiers!

Flat from DC-4.5 mc, usable to 10 mc. VERT. AMPL.: sens. 25 rms mv/in; input Z 3 megs; direct-coupled & push-pull thruout; K-follower coupling bet. stages; 4-step freq-compensated attenuator up to 1000:1. SWEEP: perfectly linear 10 cps-100 kc (ext. cap. for range to 1 cps); pre-set TV V & H positions (30 & 7875 cps); auto. sync. ampl. & lim. PLUS: direct or cap. coupling; baf. or unbal. inputs; edge-lit engraved lucite graph screen; dimmer; filter; bezel fits std photo equip. High intensity trace CRT. 0.06 usec rise time. Push-pull hor. ampl., flat to 400 kc, sens. 0.6 rms mv/in. Built-in volt. calib. Z-axis mod. Sawtooth & 60 cps outputs. Astig. control. Retrace blanking. Phasing control.



**TV-FM SWEEP**

**GENERATOR & MARKER** #368

Factory-wired **\$119<sup>95</sup>**  
Kit **\$69<sup>95</sup>**

Entirely electronic sweep circuit (no mechanical devices) with accurately-biased inductor for excellent linearity. Extremely flat RF output: new AGC circuit automatically adjusts osc. for max output on each band with min. ampl. variations. Exceptional tuning accuracy: edge-lit hairlines, 6:1 vernier. Swept Osc. Range 3-216 mc in 5 fund. bands. Variable Marker Range 2-75 mc in 3 fund. bands; 60-225 mc on harmonic band. 4.5 mc Xtal Marker Osc., xtal supplied. Ext. Marker provision. Sweep Width 0-3 mc lowest max. deviation to 0-30 mc highest max. dev. 2-way blanking. Narrow range phasing. Attenuators: Marker Size, RF Fine, RF Coarse (4-step decade). Cables: output, 'scope horiz., 'scope vertical.

#### DYNAMIC CONDUCTANCE



**Tube & Transistor Tester**

#666  
Factory-wired **\$109<sup>95</sup>**  
Kit **\$69<sup>95</sup>**

#### COMPLETE with steel cover and handle.

SPEED, ease, unexcelled accuracy & thoroughness. Tests all receiving tubes (& Color & Monochrome pic tubes with adapter). Composite indication of Gm., Gp & peak emission. Simultaneous sel of any 1 of 4 combinations of 3 plate voltages, 3 screen voltages, 3 ranges of continuously variable grid voltage (with 5% accurate pot). New series-string voltages: for 600, 450, 300 ma types. Sensitive 200 uA meter. 5 ranges meter sensitivity (1% shunts & 5% pot). 10 SIX-position lever switches: free-point connection of each tube pin. 10 pushbuttons: rapid insert of any tube element in leakage test circuit & speedy sel. of individual sections of multi-section tubes in merit tests. Direct-reading of inter-element leakage in ohms. New gear-driven rollchart. Checks n-p-n & p-n-p transistors: separate meter readings of collector leakage current & Beta using internal dc power supply.

See the 50 EICO models  
IN STOCK at your neighborhood distributor.  
Write for  
FREE Catalog **PF-9**  
33-00 Northern Boulevard, L. I. C. 1, N. Y.

Prices 5% higher in West.



# Another Britener First!



Any Set-Any Tube  
**UNIVERSAL**



Series or Parallel  
**C-BRITE**



Grid Defects  
**RESTORER**



110° Shell Base  
**C-BRITE**



110° Button Base  
**C-BRITE**



Lowest Cost - Parallel  
**VU-BRITE**



Lowest Cost - Series  
**VU-BRITE**



3 Gun Kine'  
**COLOR BRITE**



**110°**  
by the LEADER  
**Perma-Power**

Designed by engineers for quality, low cost, small size. Attractively packaged for quick, easy selling... consistently profitable.

The Perma-Power TV Tube Britener design is original and unique. It is fully protected by U. S. Patent No. 2,757,316.

**Perma-Power COMPANY**  
3100 N. ELSTON AVE. CHICAGO 18, ILL.  
Manufacturers of Electronic Equipment Since 1928

return to the rest position before all of the records have been played, decrease the bend in the link.

After the last record has played and the pickup moved through the change cycle, the rubber bumper (Fig. 23) strikes the plastic housing and causes the arm to come to rest on the pickup-arm support.

The stabilizer bar must hold records on the spindle shaft so that they will be parallel to the turntable surface. If necessary, bend the bar by twisting slightly.

The speed-change mechanism (Fig. 24) is operated through a series of linkages to raise or lower the drive pulley so that it will engage with the desired step on the motor-drive shaft. The speed index teeth cause the drive pulley to be positively engaged with the motor-drive shaft and to remain in the desired speed setting until the speed selector is moved.

Do not lubricate any part of the record-size index assembly; the lubricant will cause the parts to bind and result in erratic indexing. The service literature should be consulted before lubricating any point to make sure the correct types and amounts of lubricant are employed.

The service hints presented for the seven changers included in this two-part coverage will permit the serviceman to handle most of the troubles he will encounter on any standard design. For more complex problems, use a record-changer manual that provides complete data for the unit to be repaired. ▲

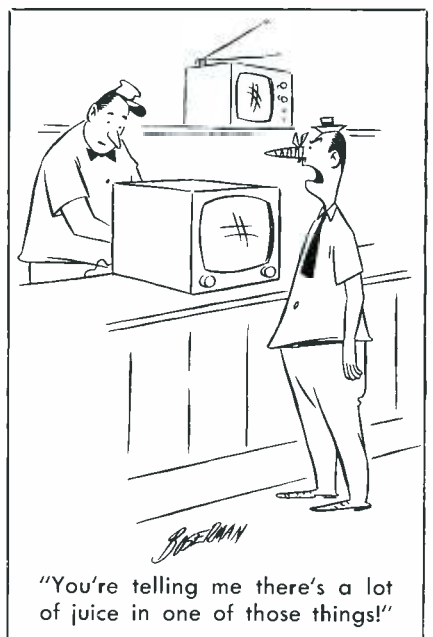

# anchor



**SANDY SAYS:**  
Use plastic box for protective storage; valuable pick-ups, needles, replacement parts, etc.

**\$5.40 LIST**

## Custom HI-FI CABLE KIT



MODEL HK510

18" 36" 72"

**5 PIECES TO MAKE CABLES FOR MOST HI-FI NEEDS!**

FIT CONNECTING cables to any Hi-Fi installation... all with one kit! Five piece cable kit... 36" phono pin with pigtailed; 18" with 2 phono pins; 72" with 2 phono pins; double phono pin jack adapter; phono plug adapter... that will make many cables such as:

PHONO PINS BOTH ENDS 18" - 72" - 91"	PHONO PIN WITH FREE END 36" - 55" - 109"
PHONO PIN, PHONO PLUG 18" - 72" - 91" - 109"	PLUG WITH FREE END 36" - 55" - 109"

FOR INFORMATION ON HI-FI PRODUCTS, WRITE

**anchor products co.**  
ELECTRONIC COMPONENTS  
2712 W. Montrose • Chicago 18, Ill.

## TV TUNERS REBUILT

ALL MAKES & MODELS  
THOUSANDS OF TUNERS IN STOCK

VHF or UHF



EXCHANGED OR OVERHAULD

**\$9.95** NET

90 DAYS WARRANTY

COMBINATION UHF/VHF UNITS

**\$19.90**

ALIGNED TO ORIGINAL STANDARDS

**SAME DAY SERVICE**

EXCHANGE TUNER SHIPPED SAME DAY  
(OTHERWISE DEFECTIVE TUNER OVERHAULD AND RETURNED: WITHIN 48 HOURS IN MOST CASES.)

Replacement tubes and smashed parts are charged extra.

Forward Tuner with All Smashed Parts  
Quote Make and Model

F.O.B. CHICAGO OR TORONTO

### CASTLE TV TUNER SERVICE

1723 W. LUNT AVE., CHICAGO 26, ILL.,	152 MAIN ST., TORONTO 13, ONT.,
<b>U.S.A.</b>	<b>CANADA</b>
AMBASSADOR 2-7505	OXford 4-5637



# PRODUCT

## REPORT

### Kit of Electrolytics

Aerovox "Stack - a - 'Lytic" kits contain eight popular values of AFH twist-prong electrolytic capacitors packed in a metal box. If desired, several of these boxes can be stacked together to form a sizable stock cabinet. In addition to a standard kit, many special assortments of capacitors can be supplied to suit individual needs.

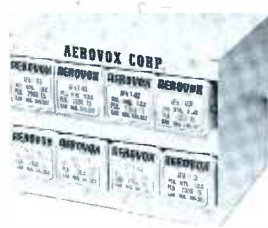

For further information, check 45V on Literature Card.

### Hole Cutters

Of especial interest to antenna-lead installers are Walsco "Stickleback" hand tools, which can be used to cut and enlarge holes in wood, plaster, plywood, or masonite panels up to 2" thick. For tougher jobs, these tools are available in a "drill-router" version, modified to fit a 1/4" chuck in a drill press or power drill.

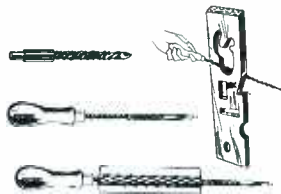

For further information, check 46V on Literature Card.

### Cable Rack

To simplify the handling of coaxial cable in a distributor salesroom or shop that must handle many varieties, Amphenol has designed a floor rack that measures 69" in height and 31 1/2" in width. Cable reels are supported by four steel axles, which are spaced so that three different sizes of reels can be stocked.



For further information, check 47V on Literature Card.

### European Tubes

Here is good news for those of you who service foreign-made equipment. European-made Valvo brand tubes, which are exact replacements for tubes employed in radios and hi-fi amplifiers imported from Germany, are now being sold in the United States by Amperex distributors.



For further information, check 48V on Literature Card.

### Soldering Tips

For delicate jobs such as cleaning solder from eyelets in printed wiring boards, Ungar Needlepoint Tiptet No. PL 338 can be inserted in any Ungar heating unit. For soldering in hard-to-reach areas, either of two slender 2" tiptets can be used — PL 833 (straight) or PL 834 (with 30° bend).



For further information, check 49V on Literature Card.

## When Converting Your Phono to Stereo Use ...

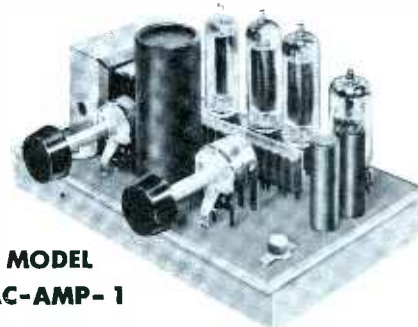

MODEL  
PAC-AMP-1

## The ERIE AUDIO-AMPLIFIER KIT

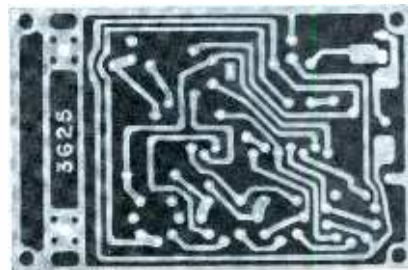

### featuring "PAC" and an ERIE Printed Wiring Board

#### With these Plug-in Components:

- ERIE "PAC" (Pre-Assembled Components)
- ERIE PRINTED BOARD
- OUTPUT TRANSFORMER
- FILTER CAPACITOR
- VOLUME CONTROL and SWITCH
- TUBE SOCKETS
- CAPACITORS
- TONE CONTROL
- TUBES

#### SPECIFICATIONS FOR ERIE STANDARD AUDIO-AMPLIFIER

- Frequency Response: 30 cycles to 12,000 cycles +0, -3.5 db.
- Sensitivity: 0.56 volt RMS (input at 1 KC) for 2 watt output.
- Power Output: 2 watts • Input Impedance: 2 megohms.
- Output Impedance: 4 ohms • AC Power Consumption: 17 watts.
- Overall Dimensions: 6 5/8" L x 4 3/16" W x 3 3/8" H.
- Shipping Weight: 2 lbs.

See and hear it at your local distributor  
or write for nearest source.



# FOR A brighter



# TV picture

Rely on the tube that has always been specified by leading independent set makers.

*Blue Chip Quality*  
 **TUNG-SOL**<sup>®</sup>  
 Magic Mirror Aluminized  
**PICTURE TUBES**

TUNG-SOL ELECTRIC INC., Newark 4, N. J. Sales Offices: Atlanta, Ga.; Columbus, Ohio; Culver City, Calif.; Dallas, Tex.; Denver, Colo.; Detroit, Mich.; Irvington, N. J.; Melrose Park, Ill.; Newark, N. J.; Seattle, Wash.

## Two-Speaker Systems

Wharfedale Ready-to-Play Two-Speaker Systems, distributed by British Industries Corp., consist of woofer and tweeter with balancing control in hard-wood cabinet enclosure. W/AF/1, with 10" woofer, is \$144.50; W/AF/2, with 12" woofer, is \$199.00. Cabinets are also available separately.



For further information, check 50V on Literature Card.

## Speaker Baffles

Examples of Argos speaker baffles with new "Forward Front" design are corner units CB-12C and SCB-12A (shown). The front panel protrudes 1/4" beyond the frame instead of being recessed in the usual style, thus giving more cabinet volume with no increase in external dimensions.



For further information, check 51V on Literature Card.

## Stereo Tape Deck

Either channel of a dual-track tape recording can be erased independently on Webster Electric Model 340. This tape deck, intended as an accessory for hi-fi systems, can record and play back both stereo and monaural sound. Retail price is \$99.50 (Deluxe, \$119.50.)



For further information, check 52V on Literature Card.

## Stereo Amplifier

Dual 14-watt amplifiers with built-in dual stereo preamps, independent bass and treble controls, and push-pull EL84 output tubes are featured in EICO Model HF81, which is priced at \$69.95 in kit form or \$109.95 wired.



For further information, check 53V on Literature Card.

## Antenna Couplers

Signals can be fed to several TV sets from a single antenna without any direct wire connection between receivers, if "Wizard" TV-FM set couplers by Charles Eng'g, Inc. are used as tapoff units. They slide over the lead-in wire and pick up a signal by electromagnetic coupling. Two types of "Wizards" are made — Model 300 for 300-ohm flat line (\$1.95) and Model .450 for wide-spaced open-wire line (\$3.30).



For further information, check 54V on Literature Card.

## Transistorized Vibrator Replacement

A transistor-switching, a-stable multivibrator circuit is used in the *Univistor*, an all-electronic replacement for any vibrator. This new plug-in component, manufactured by Universal Transistor Products Corp., has an estimated life of more than 10,000 hours and offers high operating efficiency with no moving parts to introduce electrical or mechanical noise.



For further information, check 55V on Literature Card.



### Ceramic Microphone

An omnidirectional, high-impedance ceramic microphone, Sonotone "Ceramik" Model CM-10, has a flat frequency response  $\pm 3$  db from 50-13,000 cps, and sensitivity of 57 db below 1 volt per microbar. List price is \$19.50. Size is  $5\frac{1}{8}$ " in length by  $1\frac{9}{16}$ " in diameter at grille; 7' shielded cable is attached. An accessory is a slip-in stand that adjusts to any angle.



For further information, check 56V on Literature Card.

### Stereo Adapters

David Bogen STA1 is a stereo adapter that coordinates two separate monaural amplifiers into a stereo system. Ganged volume controls, a balance control, input selectors and channel inverter are included; price is \$13.50. Also available is adapter-amplifier ST10-A that furnishes all the components needed to convert a monaural amplifier into a two-channel preamp and amplifier system for stereo sound.



For further information, check 57V on Literature Card.

### Miniature Capacitor Kit

Miniaturized tubular capacitors are being made available by Arco Electronics in kits containing 20 units having widely-used values from .001 to .1 mfd—600V. Non-inductively wound and vacuum-dipped to obtain solid impregnation, the *Elmenco dp* series offers high reliability in constant operation at temperatures and humidity conditions encountered in radio and TV circuits. Leads are #20 tinned copper and are crimped to facilitate use in printed circuits. Price of kit is \$16.50.



For further information, check 58V on Literature Card.

### FM-AM Tuner

General Electric Models FA-11 (russet) and FA-12 (gray) are FM-AM tuners featuring FM sensitivity of 5 uv for 30 db quieting, and an FM multiplex jack for use with external adapter. Price is \$129.95.



For further information, check 59V on Literature Card.

### Stereo Cartridge

New Ronette four-terminal stereo cartridges are available in both turnover and single-stylus models. The stylus assembly is similar to that on the BF-40 "Binofluid" three-terminal stereo cartridge.



For further information, check 60V on Literature Card.

### Woofers

Oxford "Tempo" woofer-type speakers are furnished in three designs. Model W12K508 has 12" diameter and a 10-oz. Alnico V magnet; W12M608 is also a 12" unit, but has a 20-oz. magnet; and W15M608 is a 15" speaker with 20-oz. magnet. Audiophile net prices are \$23.70 up.



For further information, check 61V on Literature Card.

# FOR A brighter



# profit picture

Rely on the tube that has always been a favorite with leading independent service dealers.

*Blue Chip Quality*  
 **TUNG-SOL®**  
**RECEIVING TUBES**

TUNG-SOL makes All-Glass Sealed Beam Lamps, Miniature Lamps, Signal Flashers, Picture Tubes, Radio, TV and Special Purpose Electron Tubes and Semiconductor Products.

September, 1958

Advertiser	Page No.
Acme Electric Corp.	64
Affiliated TV Labs	73
American Television & Radio Co. (ATR)	16
Amperex Electronic Products	82
Amphenol Electronics Corp.	82
Anchor Products Co.	44
Arco Electronics, Inc.	69
Argos Products Co., Inc.	40
Astron Corp.	18
B&K Mfg. Co.	9
B&M Electronics Mfg. Co.	76
Belden Mfg. Co.	17
Blonder-Tongue Labs	70, 71
British Industries Corp.	65
Bussmann Mfg. Co.	37
CBS-Hytron	35
Castle TV Tuner Service	84
Centralab, A Div. of Globe-Union, Inc.	53
Chicago Standard Transformer Corp.	80
Clarostat Mfg. Co., Inc.	41
Columbia Wire & Supply Co.	72
Cornell-Dubilier Electric Corp.	58
Doss Electronic Research	44
DuMont Labs., Inc., Allen B.	21
EICO	83
E-Z-Hook Test Products	75
Electro-Voice, Inc.	33
Electronic Publishing Co.	83
Erie Resistor Corp.	85
General Cement Mfg. Co.	73, 77
General Electric Co.	12-13, 55
Gernsback Library, Inc.	79
Hycon Electronics, Inc.	77
Injectorall Co.	73
International Rectifier Corp.	23
International Resistance Co. (IRC)	2nd Cover
Jackson Electrical Instrument Co.	65
Jensen Industries, Inc.	73
Jensen Mfg. Co.	20
Jerrold Electronics Corp.	49
KTV Tower & Communication Co.	66
Littelfuse, Inc.	4th Cover
Mallory & Co., Inc., P.R.	50, 51
Merit Coil & Transformer Corp.	67
J. W. Miller Co.	14
Mosley Electronics, Inc.	72
Oxford Components, Inc.	65
Perma-Power Co.	84
RCA Electron Tube Div.	3rd Cover
Radiart Corp.—Div. of Cornell-Dubilier Electric Corp.	58
Raytheon Mfg. Co.	15, 36
Rogers Mfg. Co.	79
Rohn Mfg. Co.	19
Sams & Co., Inc., Howard W.	39, 68, 76
Sarkes Tarzian, Inc. (Rectifier Division)	74
Sarkes Tarzian, Inc. (Tuner Division)	78
Seco Mfg. Co.	83
Service Instruments Corp.	71, 74, 76
South River Metal Products Co.	81
Sprague Products Co.	10
Sylvania Electric Products, Inc.	31
Tobe Deutschmann Corp.	59
Triad Transformer Corp.	62
Trio Mfg. Co.	45
Triplet Electrical Instrument Co.	61
Tung-Sol Electric, Inc.	86, 87
United Catalog Publishers, Inc.	75
Vis-U-All Products Co.	71, 77
Webster Electric Co.	63
Weller Electric Corp.	52
Westinghouse Electric Co.	43
Winegard Co.	47
Workman TV, Inc.	74
Xcelite, Inc.	75

## ACCESSORIES

- 1V. **ANCHOR PRODUCTS** — Complete catalog of test, service, and hi-fi equipment and accessories, with full description of functions and specifications. See ad page 84.
- 2V. **E-Z-HOOK** — A convenient reference sheet titled, "How to Build the Five Most Useful Scope Probes," with schematic, mechanical component layout, etc. See ad page 75.

## ANTENNA DISTRIBUTION

- 3V. **BLONDER-TONGUE** — Data on the TS-28 two-set TV booster and 99R all-channel UHF converter. See ads pages 70, 71.
- 4V. **JERKOLD** — New 8-page illustrated catalog on equipment for improving home TV reception, simplifying TV distribution systems, and improving TV servicing. See ad page 49.

## AUDIO EQUIPMENT

- 5V. **CENTRALAB** — 20-page booklet on a quickly-installed hi-fi compensated volume control that improves the response of radios and phonographs by automatically increasing the volume of frequencies normally lost by ordinary volume controls. See ad page 53.

## CABINETS

- 6V. **OXFORD** — New bass-reflex cabinet illustrates vertical and horizontal positioning and includes data on 3-speaker system with 3-way crossover network. Also catalog on Tempo high fidelity speakers. See ad page 65.

## CAPACITORS

- 7V. **CORNELL - DUBILIER** — Bulletin XTR-MOT on motor start-run capacitors. See ad page 58.
- 8V. **ILLINOIS CONDENSER** — New catalog sheet featuring sub-miniature electrolytic capacitors gives complete data on the Illini Type SMT tubular electrolytics including voltage and temperature ranges listed in simple chart form. Also illustrated and described is the Illini Type SMTU upright electrolytic line.
- 9V. **SPRAGUE** — "ABC's of Ceramic Capacitors," a comprehensive brochure on theory and applications. See ad page 10.
- 10V. **TOBE - DEUTSCHMANN** — 24-page indexed capacitor catalog #5701 listing types and specifications for complete line. See ad page 59.

## CARTRIDGES & NEEDLES

- 11V. **JENSEN** — New Jensen cartridge catalog. See ad page 73.

## COILS

- 12V. **J. W. MILLER** — New 72-page, 2-color TV Technician's Coil Replacement Guide which cross-references coils, filters, chokes, traps, etc. with original equipment listings. See ad page 14.

## CONTROLS

- 13V. **CLAROSTAT** — RTV-Program — TV replacements, special controls. See ad page 41.
- 14V. **IRC** — Form S-054 Dealer Stock Flyer. See ad page 2nd cover.

## FUSES

- 15V. **BUSSMANN** — Quick reference catalog to all types of fuses used in the electronic industry — Bulletin SFUS. See ad page 37.
- 16V. **LITTELFUSE** — Illustrated price sheet on fuses, fuse-holders, etc. See ad 4th cover.

## MICROPHONES

- 17V. **ELECTRO-VOICE** — Catalog No. 126 on public-address and general-purpose microphones. See ad page 33.

## PICTURE TUBES

- 18V. **SYLVANIA** — "There's a Big Difference in Television Picture Tubes," a 16-page illustrated brochure describing precision manufacturing material and techniques that contribute to the life and performance of quality picture tubes. See ad page 31.

## POWER SUPPLIES

- 19V. **ACME** — Variable Voltage Adjustor Catalog VA-312. See ad page 64.

## RESISTORS

- 20V. **MILWAUKEE RESISTOR** — Information on promotionally-priced dealer-serviceman 51-piece card replacement stock.
- 21V. **WORKMAN TV** — No. CS40 replacement guide on CANDOHM resistors. See ad page 74.

## SERVICE AIDS

- 22V. **CBS-HYTRON** — Bulletin E-292 describes new 8JP4, an aluminized 110° TV test picture tube. See ad page 35.
- 23V. **GENERAL CEMENT** — General catalog No. 158 on complete line of products. See ads pages 73, 77.
- 24V. **PERMA-POWER** — Descriptive literature on the new "Magneformer" used to magnetize and demagnetize metallic hand tools. See ad page 84.
- 25V. **SERVICE INSTRUMENTS** — New complete catalog of all Sencore units. See ads pages 71, 74, 76.

## STEREO EQUIPMENT

- 26V. **COLLARO** — Catalog describes and includes specs on performance of new line of stereo record changers featuring two-piece arm with plug-in head.
- 27V. **HARMON-KARDON** — Handy catalog sheets contain specifications and describe functions of new stereo tuners and amplifiers.

## TECHNICAL PUBLICATIONS

- 28V. **GERNSBACK** — Descriptive literature on Gernsback Library books. See ad page 79.
- 29V. **HOWARD W. SAMS** — Descriptive literature on new book, "Servicing Transistor Radios," plus new 1958 Book List including the latest technical publications on TV, radio, electronics, audio, hi-fi, etc. See ads pages 39, 68, 76.

## TEST EQUIPMENT

- 30V. **AFFILIATED TV LABS** — Catalog sheets, literature and sales plans for servicemen on complete line of self-service tube testers. See ad page 73.
- 31V. **B&K** — Bulletin AP12-R gives helpful information on new point-to-point signal-injection techniques with Model 1075 TV "analyst"; other bulletins describe "Dyna-Quick" Models 500B, 650, and automatic 675 portable dynamic mutual conductance tube and transistor testers plus Model 400 CRT cathode rejuvenator tester. See ad page 9.
- 32V. **DOSS** — Instruction manuals containing details on the new D-600 "Electrolytic Substitute," D-700 "Sync Master" and D-400 "Hi Leak" Analyzer; also on D-200 "Video Master," D-100 "Sweep Analyzer," and D-500 "Slave Oscillator." See ad page 44.
- 33V. **EICO** — New 1958 16-page catalog shows you how to save 50% on test instruments and hi-fi equipment in both kit and factory-wired form. See ad page 83.
- 34V. **HYCON** — 2-color data sheet on Model 645AR rack-mounted digital volt-ohmmeter contains complete specifications and describes operating principles. Unit reads DC volts, AC volts, and resistance with accuracy of 0.1% on DC and ohms — 1% on AC from 10 to 1000 volts. See ad page 77.
- 35V. **JACKSON** — Folder covering entire line of "Service Engineered" test equipment. See ad page 65.
- 36V. **TRIPLETT** — Circular on universal VOM-VTVM. See ad page 61.
- 37V. **VIS-U-ALL** — Descriptive literature on Model V200 picture tube tester and reactivator. See ads pages 71, 77.

## TOOLS

- 38V. **WELLER** — 2-color flyer illustrating new soldering irons with built-in Magnastat Temperature Control. See ad page 52.
- 39V. **XCELITE** — Complete tool catalog. See ad page 75.

## TRANSFORMERS

- 40V. **CHICAGO STANDARD** — 100-page TV Transformer Replacement Guide, cross referenced for over 7,000 chassis of 98 manufacturers. See ad page 80.
- 41V. **MERIT** — "Service Technician's Handbook" lists part numbers and prices of products in company's line. See ad page 67.

## TUBES

- 42V. **GENERAL ELECTRIC** — Receiving-tube interchangeability chart lists 122 television and radio types which can directly replace 180 others. See ads pages 12-13, 55.
- 43V. **RAYTHEON** — Revised 14-page Television Picture Tube Characteristics booklet includes data on aluminized black-and-white and color tubes, face-plate deflection angle, bulb dimension, ion-trap information, and basing diagrams. See ads pages 15, 36.

## WIRE

- 44V. **COLUMBIA WIRE** — New 4-page supplement to Catalog No. 107. See ad page 72.



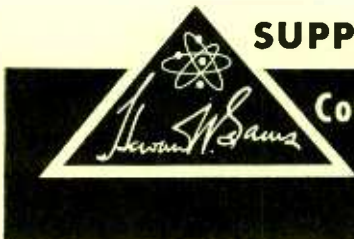

# SUPPLEMENT TO SAMS AUGUST 1958 MASTER INDEX

Covers PHOTOFACT Set Numbers 411 through 414 Released

# SEPTEMBER

This Supplement is your index to new models covered by PHOTOFACT in September 1958. For model coverage prior to this date see the Sams Master Index dated August 1958. Use this Supplement with the Sams Master Index—together they are your complete Index to PHOTOFACT coverage of over 30,000 receiver models.

	Set No.	Folder No.
<b>ADMIRAL</b>		
Chassis 4W2	411-4	
Chassis 5E4	412-4	
Chassis 6B3	404-12-5	
Chassis 6S2	413-4	
202	411-4	
215, 217, 218	411-4	
221, 227, 228	413-4	
284, 288, 289	412-4	
303, 304	404-12-5	
<b>AIRLINE</b>		
GRD-8514A, GRD-8515A (See Photofact Servicer)	413	
GRD-8517A, GRD-8518A (See Photofact Servicer)	413	
GTM-1638A, GTM-1639A, B	411-5	
GTM-4201A	413-16-5	
GTM-4301A	413-16-5	
WG-4204A	403-12-5	
<b>ALLSTATE</b> (See Auto Radio Listing)		
<b>ANDREA</b>		
●BLB-VP21-110 (Ch. VP21-110)	413-1	
●BT-VP21-110 (Ch. VP21-110)	413-1	
●ET-VP21-110 (Ch. VP21-110)	413-1	
●FLB-VP21-110 (Ch. VP21-110)	413-1	
●FT-VP21-110 (Ch. VP21-110)	413-1	
●LB-VP21-110 (Ch. VP21-110)	413-1	
●T-VP21-110 (Ch. VP21-110)	413-1	
Ch. VP21-110	413-1	
<b>ARVIN</b>		
1581 (Ch. 1.44000)	411-6	
Ch. 1.44000	411-6	
<b>AUTOMATIC</b> (Also See Auto Radio Listing)		
<b>BLAUPUNKT</b> (Also See Auto Radio Listing)		
<b>CADILLAC</b> (See Auto Radio Listing)		
<b>CHEVROLET</b> (See Auto Radio Listing)		
<b>CHRYSLER</b> (See Auto Radio Listing)		
<b>COLUMBIA RECORDS</b>		
HF-2	411-8	
532	413-6	
535	412-6	
583	412-6	
710	412-6	
<b>CORONADO</b>		
●TV3-9402A	398-1	
<b>DESOTO</b> (See Auto Radio Listing)		
<b>DODGE</b> (See Auto Radio Listing)		
<b>DUMONT</b>		
●RA-406, RA-407	414-1	
Sportsman 17	414-1	
<b>EMERSON</b>		
●C502C, C503C, C504A, C505A (Ch. 120296D, 120297A)	412-1	
●C506A, C507A (Ch. 120319D, 120320A)	412-1	
886D (Ch. 120371B)	413-7	
●1414, 1415 (Ch. 120407S, 120408S)	411-19-5	
●1432, 1433 (Ch. 120422S, 120423U)	411-19-5	
●1434, 1435 (Ch. 120420S, 120421U)	411-19-5	
●1438, 1439 (Ch. 120417S, 120418U)	411-19-5	
●1440, 1441 (Ch. 120417S, 120418U, 120419B)	411-19-5	
●1452, 1453 (Ch. 120424W, 120425Y)	412-17-5	
●1466, 1467 (Ch. 120434N, W, 120435P, Y)	412-17-5	
●1470, 1471 (Ch. 120445W, 120446Y)	412-17-5	
Ch. 120296D, 120297A	412-1	

	Set No.	Folder No.
<b>EMERSON—Cont.</b>		
Ch. 120319D, 120320A	412-1	
Ch. 120371B	413-7	
Ch. 120407S, 120408U	411-19-5	
Ch. 120417S, 120418U, 120419B, 120420S, 120421U, 120422S, 120423U	411-19-5	
Ch. 120424W, 120425Y	412-17-5	
Ch. 120434N, W, 120435P, Y	412-17-5	
Ch. 120445W, 120446Y	412-17-5	
<b>FAIRCHILD (Also See Record Changer Listing)</b>		
<b>FIRESTONE</b>		
4-A-177, 4-A-179 (Code 1-7-5T11, 1-7-5C9)	412-7	
<b>FORD</b> (See Auto Radio Listing)		

	Set No.	Folder No.
<b>OLDSMOBILE</b> (See Auto Radio Listing)		
<b>OLYMPIC</b>		
●CD108, U, CD109, U, CD110, U (Ch. GD, GDU) (Run 5 and above)	409-18-5	
●CH402, U (Ch. GH, GHU) (Run 5 and above)	409-18-5	
●KD118, U, KD119, U, KD120, U (Ch. GD, GDU) (Run 5 and above)	409-18-5	
●KD188, U (Ch. GD, GDU) (Run 5 and above)	409-18-5	
●KH406, U, KH407, U (Ch. GH, GHU) (Run 5 and above)	409-18-5	
●PKD118, U, PKD119, U (Ch. GD, GDU) (Run 5 and above)	409-18-5	

	Set No.	Folder No.
<b>SILVERTONE (Also See Record Changer and Recorder Listing)</b>		
1333 (Ch. 185.806) (See Photofact Servicer)	412	
1334 (Ch. 185.807) (See Photofact Servicer)	412	
1336 (Ch. 185.809) (See Photofact Servicer)	412	
1392 (Ch. 185.10200) (See Photofact Servicer)	414	
1393, 1394 (Ch. 185.10300) (See Photofact Servicer)	414	
1395 (Ch. 185.10400) (See Photofact Servicer)	414	
●8100BE, GR (Ch. 528.50180, 181, 182)	411-2	
●8102AAQ, ACL, AQ, CL, YL (Ch. 582.50200, 201, 202)	411-2	
●8106 (Ch. 582.50200, 201, 202)	411-2	

	Set No.	Folder No.
<b>STUDEBAKER</b> (See Auto Radio Listing)		
<b>SYLVANIA</b>		
3203GR, 3204TU, 3204YE (Ch. 1-617-1)	412-14	
4501 (Ch. 1-624-1)	411-17	
Ch. 1-617-1	412-14	
Ch. 1-624-1	411-17	
<b>TOWER</b> (See Recorder Listing)		
<b>TRAV-LER</b>		
●17MT65 (Ch. 743-48)	414-3	
●721-K-610 (Ch. 775-88)	414-3	
●721-K-630, U (Ch. 743-28)	412-3	
●721-LP-650 (Ch. 775-88)	414-3	
●721-MT-600 (Ch. 775-88)	414-3	
●721-MT-620, U (Ch. 743-28)	412-3	
●1722 (Ch. 775-88)	414-3	
●1723, U (Ch. 740-78)	414-3	
●1724 (Ch. 775-88)	414-3	
●1730, 1731 (Ch. 729-26, 775-57)	413-2	
●1760, U (Ch. 743-18)	412-3	
Ch. 729-26	413-2	
Ch. 740-78	414-3	
Ch. 743-18, -28	412-3	
Ch. 743-48	414-3	
Ch. 744-88	402-16-5	
Ch. 775-57	413-2	
Ch. 775-88	414-3	
<b>TRUETONE</b>		
D3716B	414-9	
●2DC1831A, 2DC1833A	403-4	
●2DC1835A, 2DC1837A	402-4	
●2DC1841A, 2DC1843A, 2DC1845A	393-3	
●2DC1900A, 2DC1901A	409-18-5	
●2DC2831A, 2DC2833A	403-4	
●2DC2841A, 2DC2843A	393-3	
●2DC3840A	407-15-5	
●2DC3900A, 2DC3901A	409-18-5	

## THIS IS YOUR LATEST INDEX SUPPLEMENT!

### FOR COMPLETE PHOTOFACT LISTINGS

USE IT WITH THE AUGUST 1958 MASTER INDEX!

# THROW AWAY

## ALL OTHER SUPPLEMENTS

	Set No.	Folder No.
<b>GENERAL ELECTRIC</b>		
C415, C416, C417	412-9	
P725B, P726B	414-4	
P735A, P736A	411-9	
P750A	414-4	
●21T2425, 21T2426 ("M4" Line)	402-16-5	
850	325-6	
<b>HALLICRAFTERS</b>		
●17PT (Ch. B2014)	412-2	
●1790P (Ch. A2014)	412-2	
●1790U (Ch. B2014)	412-2	
Ch. A2014, B2014	412-2	
<b>HARMAN-KARDON</b>		
TA-12	414-5	
<b>HOTPOINT</b>		
●14S208, -UHF, 14S209, -UHF ("Q3" Line)	414-2	
<b>IMPERIAL</b> (See Auto Radio Listing)		
<b>KNIGHT</b>		
KN-200 (92S2405)	411-10	
KN-315 (92S2410)	412-10	
92S2405	411-10	
92S2410	412-10	
<b>LINCOLN</b> (See Auto Radio Listing)		
<b>MAGNAVOX</b>		
Chassis CR-744AA	413-10	
●Chassis U27-01AA, U27-02AA, U27-03AA, U27-04AA	411-1	
●Chassis V27-01AA, V27-02AA, V27-03AA, V27-04AA	411-1	
<b>MERCURY</b> (See Auto Radio Listing)		
<b>MOTOROLA</b> (Also See Auto Radio Listing)		
5P22GW-1, RW-1, S-1, 5P23E-1, PN-1, WB-1 (Ch. HS-647)	363-14	
6P25E, N, S (Ch. HS-637)	364-6	
Ch. HS-637	364-6	
Ch. HS-647	363-14	

	Set No.	Folder No.
●TD102, U (Ch. GD, GDU) (Run 5 and above)	409-18-5	
Ch. GD, GDU, GH, GHU (Run 5 and above)	409-18-5	
<b>PACKARD</b> (See Auto Radio Listing)		
<b>PHILCO</b>		
F-743, F-750, F-752, F-754, F-758	413-12	
F-809, F-813, F-815, F-817	413-12	
F-1900, F-1902	404-12-5	
HFT-1	404-12-5	
RT-200, RT-200-1, RT-201	404-12-5	
T-9	404-12-5	
T-R	405-17-5	
<b>PHONOLA</b>		
158	354-14	
358	354-14	
558	354-14	
1257, 1357	399-10	
<b>PLYMOUTH</b> (See Auto Radio Listing)		
<b>PONTIAC</b> (See Auto Radio Listing)		
<b>RCA VICTOR</b>		
●14PD9030, U, 14PD9033, U, 14PD3034, U (KCS 120A, B)	410-18-5	
●14PT9011, U, 14PT9012, U (Ch. KCS 120A, B)	410-18-5	
Ch. KCS 120A, B	410-18-5	
<b>SEIMENS</b>		
T333USA (See Photofact Servicer)	411	
1135W (See Photofact Servicer)	411	
<b>SETCHEL-CARLSON</b>		
●P64 (Ch. C102A)	407-15-5	
●58C21 (Ch. 258-A)	406-14-5	
Ch. C102A	407-15-5	
Ch. 258-A	406-14-5	

	Set No.	Folder No.
●8110, 8111, 8112, 8113 (Ch. 528-50220, 221, 230, 240)	411-2	
●8146, 8147 (Ch. 582.50240, 250)	411-2	
●8150, 8151, 8152, 8153 (Ch. 528-50220, 221, 230, 240)	411-2	
8220 (Ch. 582.53140)	414-13	
●9100, EB, FG, 9101, EB, FG, 9102AQ, BL, CG, GY, 9103AG, BL, CL, GY (Ch. 528.50240, 250)	411-2	
●9110, 9111 (Ch. 528.50240, 270)	411-2	
●9118, 9119 (Ch. 528.51220, 230)	400-14-5	
●9150, 9151 (Ch. 528.50240, 270)	411-2	
9231, 9234 (Ch. 528.56003, 4)	386-10	
Ch. 185.806 (See Photofact Servicer)	412	
Ch. 185.807 (See Photofact Servicer)	412	
Ch. 185.809 (See Photofact Servicer)	412	
Ch. 185.10200 (See Photofact Servicer)	414	
Ch. 185.10300 (See Photofact Servicer)	414	
Ch. 185.10400 (See Photofact Servicer)	414	
Ch. 528.50180, 528.50181, 528-50182	411-2	
Ch. 528.50200, 201, 202	411-2	
Ch. 528.50220, 528.50221	411-2	
Ch. 528.50230	411-2	
Ch. 528.50240	411-2	
Ch. 528.50250	411-2	
Ch. 528.50270	411-2	
Ch. 528.51220, 528.51230	400-14-5	
Ch. 528.53140	414-13	
Ch. 528.56003, 528.56004	386-10	
<b>SONIC</b>		
450	412-12	
470	411-15	

	Set No.	Folder No.
<b>V-M</b>		
557	414-10	
562, 566, 568	414-10	
<b>WECOR</b> (See Webster-Chicago) (Also See Recorder Listing)		
<b>WEBSTER-CHICAGO</b>		
1891	412-15	
<b>WELLS-GARDNER</b>		
●321N73-A-3701	413-3	
●321N73-A-3750	413-3	
●321N73-A-3762	413-3	
●321N73-A-3791	413-3	
●321N73-A-3703	413-3	
●321N73-A-3752	413-3	
●321N73-A-3763	413-3	
●321N73-A-3793	413-3	
●3321N73-A-3798	413-3	
<b>WESTINGHOUSE</b>		
●H-21K210, A, H-21K211, A (Ch. V-2364-1, -3)	411-3	
●H-21KU210, A, H-21KU211, A (Ch. V-2364-2, -4)	411-3	
●H-21T206, A, H-21T207, A (Ch. V-2364-1, -3)	411-3	
●H-21TU206, A, H-21TU207, A (Ch. V-2364-2, -4)	411-3	
H-651PE, H-652PE, H-653PE (Ch. V-2278-4)	411-18	
●H-988-1R, -1T (TV Remote Control)	388-3	
<b>HR-1028N, HR-1038N (Ch. V-2500-2, V-2502-1)</b>		
Ch. V-2278-4	411-18	
Ch. V-2364-1, -2, -3, -4	411-3	
Ch. V-2500-2	413-15	
Ch. V-2502-1	413-15	
<b>ZENITH</b>		
Royal 300F, R, Y (Ch. 7AT4221)	412-16	
Royal 1000	405-17-5	
Ch. 7AT4221	412-16	

NOTE: PCB Denotes Production Change Bulletin. ● Denotes Television Receiver. S Denotes Schematic Coverage Only.

Set Folder  
No. No.

## AUTO RADIOS

**ALLSTATE**  
6231, 6232 (Ch. 528.62310, 320) ..... 413-5  
Ch. 528.62310, 528.62320 413-5

**AUTOMATIC**  
CRT-97, CTR-77, CTR-77A, DET-27,  
FTP-37A ..... 403-12-5

**BLAUPUNKT**  
"Frankfurt" (K150001) ..... 393-7  
"Hamburg" (S300001) ..... 394-8  
"Köln" (K182520) ..... 392-7

**CADILLAC**  
7270405, 7270555 ..... 411-7

**CHEVROLET**  
987730 ..... 412-5  
3748611 ..... 412-5

**CHRYSLER**  
(See Mopar)

**DESOTO**  
(See Mopar)

**DODGE**  
(See Mopar)

**FORD**  
FEM-18805-A, -B ..... 412-8  
FEV-18805-F ..... 413-9  
748T (FEM-18805-A) ..... 412-8  
848T (FEM-18805-B) ..... 412-8  
84MS (FEV-18805-F) ..... 413-9

**IMPERIAL**  
(See Mopar)

**LINCOLN**  
FFC-15491-B ..... 394-17-5  
FFC-18805-C, -D ..... 394-17-5  
FFC-18805-C, -D (Above Serial No.  
50,000) ..... 401-16-5  
85BH (FFC-18805-C, -D) ..... 394-17-5  
85BHP (FFC-18805-C, -D) (Above  
Serial No. 50,000) ..... 401-16-5  
88BH (FFC-15491-B) ..... 394-17-5

**MERCURY**  
FEW-18805-T ..... 411-11  
85BM (FEW-18805-T) ..... 411-11

**MOPAR**  
922 ..... 414-6  
923 ..... 413-11  
924 (C-5809) ..... 398-17-5  
925 (P-5803) ..... 398-17-5

**MOTOROLA**  
GV-800 ..... 410-18-5  
8M ..... 411-12  
8MX ..... 401-16-5

**OLDSMOBILE**  
989127 ..... 411-13  
989129 ..... 412-11

**PACKARD**  
AC-2906 ..... 411-16  
AC-2907 ..... 412-13

**PLYMOUTH**  
(See Mopar)

**PONTIAC**  
988822 ..... 411-14

**STUDEBAKER**  
AC-2906 ..... 411-16  
AC-2907 ..... 412-13

## RECORD CHANGERS

**FAIRCHILD**  
412-4 ..... 413-8

## RECORDERS

**PENTRON**  
NL-1, -1S, NL-2, -2S, NL-3, -3S  
..... 414-7  
TM-1, -4 ..... 414-7

**SILVERTONE**  
9070 (Ch. 528.58002, 528.59062)  
..... 380-11  
9072 (Ch. 528.58100, 528.59210)  
..... 380-11

**TOWER**  
4691 ..... 414-8

**WEECOR**  
2811, 2821, 2891 ..... 413-14

## MULTIPLE TV INSTALLATIONS MADE EASY!



GET ALL THE KNOW-HOW IN THIS VALUABLE SAMS BOOK

## "TV DISTRIBUTION SYSTEMS and ANTENNA TECHNIQUES"

by Jack Beever



### MAKES YOU AN EXPERT ON MULTIPLE TV INSTALLATION

Here's complete information on how to feed TV signals to multiple TV sets from a single antenna system. Describes equipment required to solve signal distribution problems; shows how to use equipment properly. Covers every type of multiple-set system from simple two-receiver service to large commercial installations. Full information on how to solve difficult "local" reception problems and how to get good fringe area results. Describes community antenna systems—planning, equipment, installation, legal problems, costs, maintenance, service charges—all the facts.

### 17 FACT-PACKED CHAPTERS:

You get detailed practical information on: selection, location and orientation of the antenna—recommended signal distribution systems and how to install them—requirements for coaxial cable, set outlets or tap-offs—available equipment for amplifying and filtering signals—modernizing or converting a system for UHF—how to maintain the system, what to charge—even how to prepare bids and estimates and make the sale! It's complete—it's practical—tells you everything you need to know to build a profitable business in multiple TV installations. Order today!

176 pages, 5½ x 8½" \$295  
PRICE ONLY



### PROFITABLE BUSINESS

- Hotels
- Motels
- Apartments
- Institutions
- Stores, etc.

## SAVE TV REPAIR TIME!

### WITH HOWARD W. SAMS "Television Tube Location Guides"

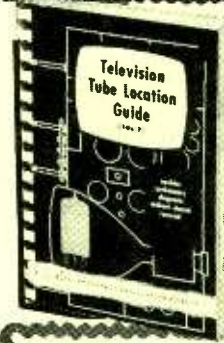

shows position and function of all tubes in thousands of TV sets...

JUST FIND THE TROUBLE AND REPLACE TUBES WITHOUT REMOVING CHASSIS!

### YOU GET ALL THIS HELP:

- Shows tube type and function
- Shows major component placement
- Charts are oriented as you view chassis
- Identifies unknown chassis quickly
- Speeds tube checking
- Locates tube in "wrong" socket
- Over 500 models covered in each Guide
- Convenient size for pocket or caddy
- Complete cumulative index in each Guide

### "EXTRAS" NOW IN VOL. 7

- Shows signal path
- Shows pin orientation on socket
- Shows series string filaments
- Includes tube failure check charts
- Shows fuse location



### OWN THEM ALL—THEY HELP YOU EARN MORE

**VOL. 7.** Covers TV receivers produced in 1956-1957. 204 pages. Only ..... \$2.00

**VOL. 6.** Covers TV receivers produced in 1955-1956. 236 pages. Only ..... \$2.00

**VOL. 5.** Covers TV receivers produced in 1953-1954. 200 pages. Only ..... \$2.00

**VOL. 4.** Covers TV receivers produced in 1952-1953. 192 pages. Only ..... \$2.00

**VOL. 3.** Covers TV receivers produced in 1951-1952. 192 pages. Only ..... \$2.00

**VOL. 2.** Covers TV receivers produced in 1950-1951. 208 pages. Only ..... \$2.00

**VOL. 1.** Covers TV receivers produced in 1948-1949, 1950. 208 pages. Only ..... \$2.00

own these SAMS "BEST SELLERS"

# See These Books at your SAMS Distributor NOW!



# Diagnosis... A Long and Healthy Life!

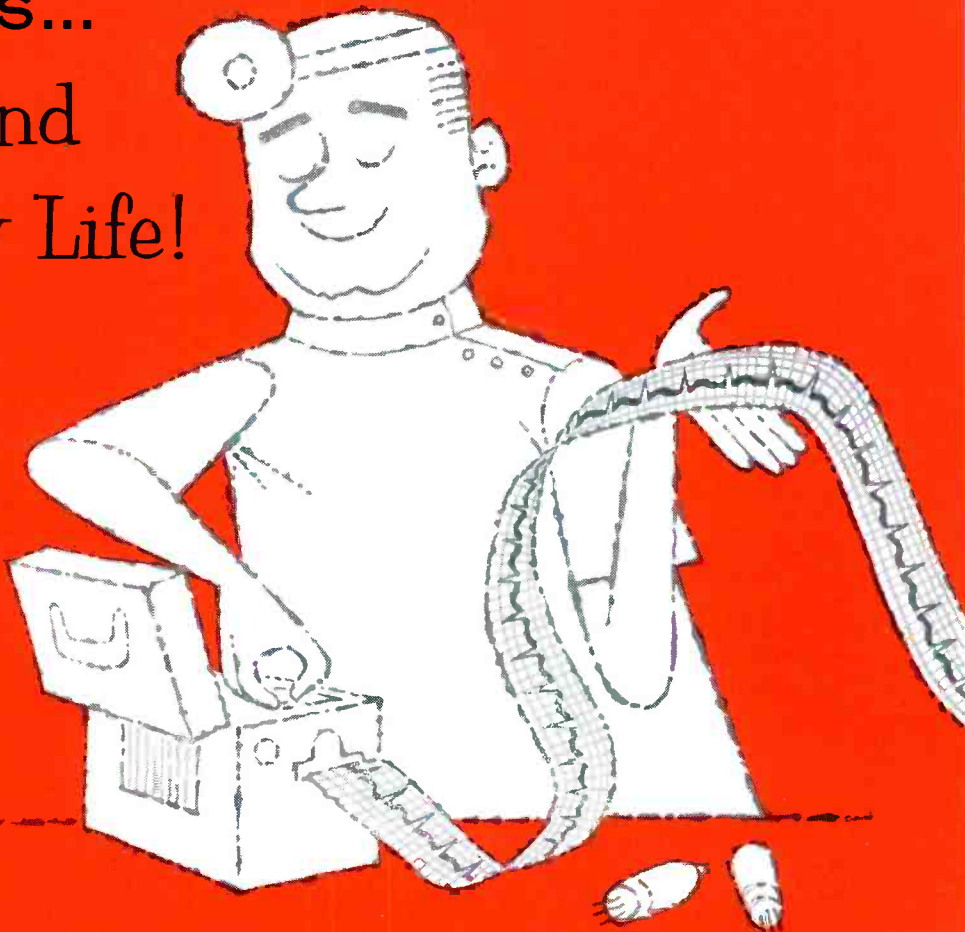

...for the RCA-6AU4-GTA

A "diagnosis" of the RCA-6AU4-GTA shows why it gives top performance for extended hours of operation.

*Tube life is increased* through improved heat dissipation, achieved with an increased bulb area, new plate shape, and the use of special "clad" plate material. *Early-hour failure is minimized* by elaborate precautions against internal contamination during production. *Borderline tubes are eliminated* through emission tests at extremely low heater voltage, and by aging and life tests at increased plate dissipation. The result is a tube with an unusual ability to resist plate-to-cathode arcing and internal breakdowns.

RCA-6AU4-GTA—*preferred* for TV damper circuits by original equipment designers—is a tube you can rely upon for replacement purposes. Do the same as *all* experienced TV technicians do, always ask your RCA Tube Distributor for RCA tubes!



**Speed Up and Simplify Your  
Color-TV Servicing With  
RCA's New PICT-O-GUIDE**

It's check-full-of practical information and illustrations—just what you need for profitable color-TV servicing. Available through your RCA Tube Distributor or send check or money order for \$4.50 payable to Radio Corporation of America, to RCA Commercial Engineering, 415 South 5th St., Harrison, New Jersey.



**RADIO CORPORATION OF AMERICA**

Electron Tube Division

Harrison, N. J.



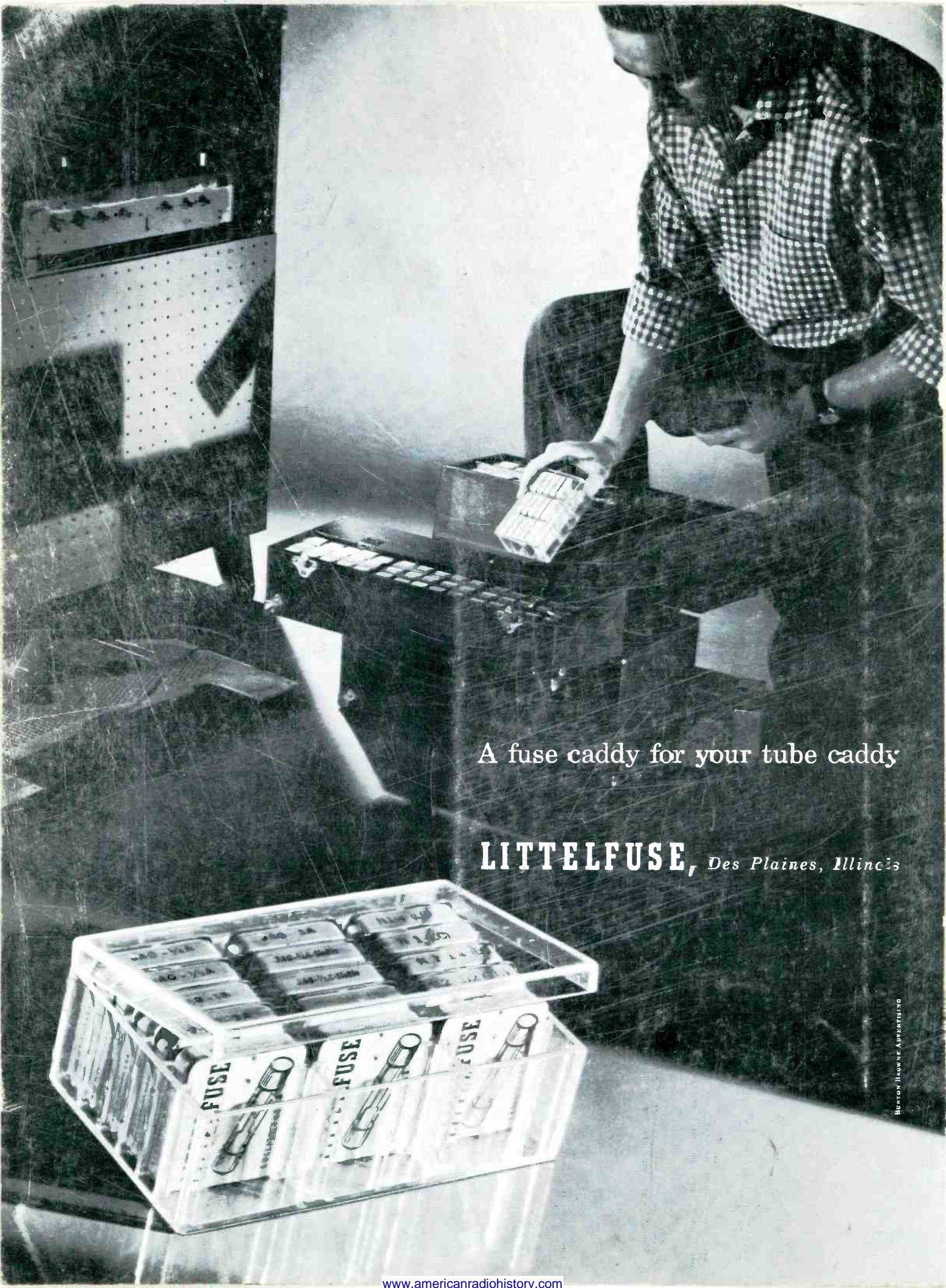

A fuse caddy for your tube caddy

**LITTELFUSE**, *Des Plaines, Illinois*

BURTON BROWN ADVERTISING