

FEBRUARY • 1958 25 CENTS



**PF**  
PHOTOFACT

# REPORTER

FOR THE ELECTRONIC SERVICE INDUSTRY



**Audio Facts—page 20**

**REGENERATION—page 12**

**Now—Automatic Fine Tuning—page 44**

**WIRE & ITS USES—page 14**

# YOUR BIG IRC® BARGAIN

all these types—coverage of



Universal Knob  
Master Shaft

3/16" Universal  
Shaft

1/4" Full  
Round Shaft

Insulated  
Shaft

3 Shaft Lengths  
Tab Mounted Controls

2 Screw-driver  
Slotted Shafts

2 Special  
Tongued Shafts

Full Coverage of Type Q Carbon Controls—44 electrical values, tapers and taps in 11 shaft styles—provides coverage of 484 different carbon controls for 84% replacement usage.

**IRC® GIVES YOU COVERAGE OF MOST**

in 1 convenient dealer

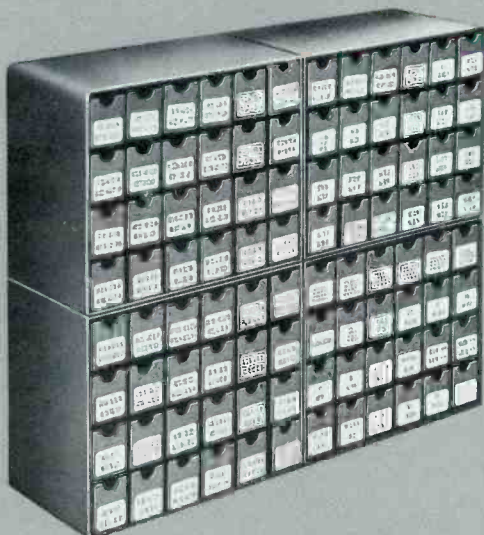

**Dealer Parts Stock #22**

**ONLY \$113<sup>00</sup>**

- Sturdy 24 drawer 9" x 12" master stockers supplied free
- 96 identified compartments
- All replacement information and assembly instructions included

# IN CONTROLS

# \$ 113 00

4400 parts numbers

ONLY

DEALER  
COST

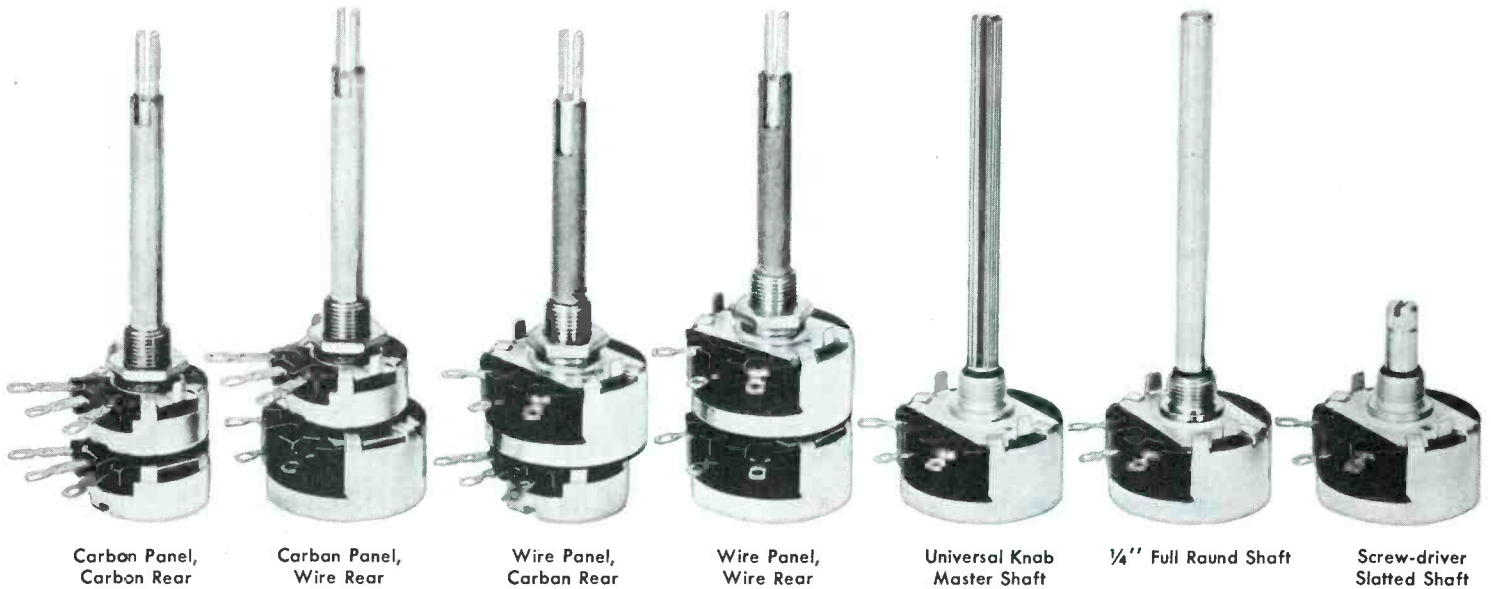

Coverage of over 700 Exact Duplicate Concentric Dual Controls in 4 basic control combinations.

Broad coverage of 2 to 4 watt Single Wire Wound Controls—13 electrical values, tapers and taps in 3 shaft styles—to provide 39 different wire wound controls covering 55% replacement usage.

## NEEDED REPLACEMENT CONTROLS

stock—\$1370 worth of control coverage

NOW YOU CAN HAVE EVERYTHING YOU NEED TO HANDLE ALMOST ANY REPLACEMENT CONTROL RIGHT AT YOUR BENCH. IRC DEALER STOCK # 22 PROVIDES BASIC PARTS GIVING THE SAME COVERAGE AS \$1370 WORTH OF IRC FACTORY-ASSEMBLED CONTROLS. YOU HAVE THE CONTROL YOU NEED WHEN YOU NEED IT. ASSEMBLES QUICKLY. ACCURACY AND FIT ARE GUARANTEED!

You can assemble any of 809 different IRC controls from this compact bench stock. The IRC # 22 Dealer Stock gives you a coverage of over 50% of IRC's color TV controls. Speed up your service time and save ordering time. Order an IRC # 22 Dealer Stock today.



**INTERNATIONAL RESISTANCE CO.**

Dept. 361, 401 N. Broad St., Philadelphia 8, Pa.

**Sprague Service-Aids for servicemen:**



.1 MF GMV  
500 WVDC  
5HK-P1

**... versatile CERA-MITE\* CERAMIC CAPACITORS with handy identification tags**

Sprague's complete ceramic capacitor line is now individually tagged for quick, *complete* identification—capacitance, tolerance, voltage, and type. No fumbling, no guessing about ratings ... you're always sure with Sprague *tagged* disc capacitors. Use them all the time. You'll find that they also make excellent replacements for molded mica, ceramic tubular, and paper tubular capacitors in many applications

Stock up today! Ask your distributor about Sprague CERAMIKITS ... they contain the ceramic disc capacitors you need most ... they keep them in order ... ready to use.

\*Trademark

**... helpful INFORMATION on what, when, and how of ceramic capacitors**

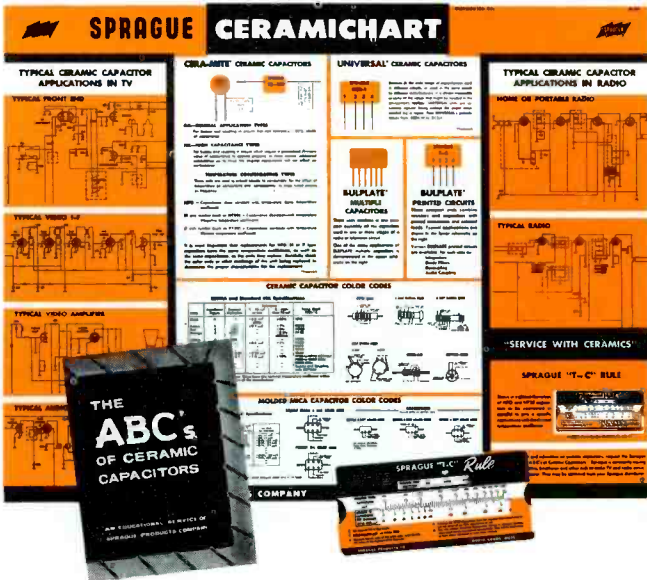

Sprague offers you plenty of service information ... the kind you need and use everyday:

*Sprague CERAMICHART*: illustrates various types of ceramic capacitors and shows where to use them; details color codes.—FREE

*Sprague "ABC's of Ceramic Capacitors"*: a compact booklet containing basic facts on all types of ceramic capacitors.—FREE

*Sprague "T-C" Slide Rule*: shows at a glance the values of the N750 and NP0 type ceramic capacitors to connect in parallel to equal a capacitor of desired intermediate temperature coefficient of the required capacitance; available from your distributor for only 15c.

Be sure you get this useful and valuable information from your Sprague distributor, today! Or write Sprague Products Co., Distributors' Division of Sprague Electric Company, 105 Marshall Street, North Adams, Mass.

**Pioneer in ceramic capacitors ... First in ceramic capacitor information**

**don't be vague ... insist on**



**SPRAGUE RESEARCH IS CONSTANTLY PRODUCING NEW AND BETTER CAPACITORS FOR YOU**

PUBLISHER  
Howard W. Sams  
GENERAL MANAGER  
Mal Parks, Jr.

EDITOR  
Verne M. Ray

ASSOCIATE EDITORS  
Leslie D. Deane  
Thomas A. Lesh  
Calvin C. Young, Jr.

CONSULTING EDITORS  
William E. Burke C. P. Oliphant  
Robert B. Dunham George B. Mann  
Paul C. Smith

ART DIRECTOR EDITORIAL ASSISTANT  
Don W. Bradley Judy Ann Hurley

PHOTOGRAPHY CIRCULATION  
Robert W. Reed Pat Tidd

ADVG. PRODUCTION ART ASSISTANT  
Carol B. Gadbury Phillip W. Lee

#### ADVERTISING SALES OFFICES

MIDWESTERN  
PF REPORTER,  
2201 East 46th Street, Indianapolis 5, Ind.  
Clifford 1-4531

EASTERN  
Paul S. Weil and Donald C. Weil,  
39-01 Main Street, Flushing 54, New York.  
Independence 3-9098.

WESTERN  
The Maurice A. Kimball Co., Inc.  
2550 Beverly Blvd., Los Angeles 57, Calif.  
Dunkirk 8-6178; and 681 Market Street,  
San Francisco 5, Calif. EXbrook 2-3365.

Published monthly by Howard W. Sams & Co., Inc., at Indianapolis 5, Indiana.  
Entered as second class matter October 11, 1954, at the Post Office at Indianapolis, Indiana, under the Act of March 3, 1879.

Copyright 1958 by Howard W. Sams & Co., Inc. No part of the PF REPORTER may be reproduced without written permission. No patent liability is assumed with respect to the use of information contained herein.

Subscription prices in U.S.A. and possessions: 1 yr., \$3.00; 2 yrs., \$5.00; 3 yrs., \$7.00. In Canada and Pan America: 1 yr., \$3.60; 2 yrs., \$6.00; 3 yrs., \$8.50. Foreign subscriptions: 1 yr., \$6.00; 2 yrs., \$11.00; 3 yrs., \$15.00. A limited quantity of back issues are available at 35c per copy.

## next month

### INDOOR ANTENNAS

During the past few years, indoor TV antennas have become very popular, with the result that many new designs have been introduced. Next month's picture story will explain the principles upon which the basic indoor type works, using them to describe the theory behind several of the most popular examples.

### SIGNAL TRACING RF & IF CIRCUITS

Do these circuits give you a headache, or do you have trouble using sweep-signal generators, oscilloscopes and probes? If so, don't miss this article in the March issue for the real low-down on isolating troubles in these tuned circuits.

### SELECTION & USE OF HAND TOOLS (Part 2)

Part 2 of this article presents a coverage of diagonal cutters, pliers of all styles, various types of wrenches (including crescent, hex and spline), bolt cutters, terminal crimpers, wire strippers and some of the miscellaneous items designed to help you complete your jobs faster and more easily.

VOLUME 8, No. 2



FEBRUARY, 1958

# PF REPORTER

FOR THE ELECTRONIC SERVICE INDUSTRY

## CONTENTS

<b>This Month's Cover</b> .....	65
<b>Letters to the Editor</b> .....	8
<b>Shop Talk</b> .....	10
TV antennas—principles of transmission and reception, resonance, directional response and impedance matching.	<i>Milton S. Kiver</i>
<b>Regeneration</b> .....	12
Symptoms of interference or ghosts? May be a case of regeneration.	<i>Robert G. Middleton</i>
<b>Wire and Its Uses</b> .....	14
Look this one over carefully—it will help on your next wire purchase.	
<b>Audio Facts</b> .....	20
A study of equalization networks; Columbia Model 583 packaged hi-fi; some new audio products.	<i>Calvin C. Young, Jr.</i>
<b>Dollar &amp; Sense Servicing</b> .....	22
<b>The Troubleshooter</b> .....	24
<b>Quicker Servicing</b> .....	26
Analyzing interacting circuits; servicing sets with voltage-divider stages; CRT testing in the home; a new servicing lamp.	<i>Calvin C. Young, Jr.</i>
<b>Servicing Industrial Electronics</b> .....	32
Liquid sensing for analysis and control of chemical solutions in manufacturing.	<i>Melvin Whitmer</i>
<b>A System for Starting on Dogs</b> .....	38
“Tough Dog” on the bench? Here's an approach used by an expert.	<i>Art Margolis</i>
<b>Now—Automatic Fine Tuning</b> .....	44
Better bone up on the circuitry in this new tuner—you'll be servicing it soon.	<i>Thomas A. Lesh</i>
<b>Troubleshooting With George</b> .....	50
Two cases this month—motorboating and sound bars during warmup plus a picture that shifts sideways.	<i>Les Deane</i>
<b>Let's Talk Business</b> .....	67
Teach your wife the business—it's better than life insurance!	<i>Ernest W. Fair</i>
<b>Product Report</b> .....	69
<b>Free Catalog &amp; Literature Service</b> .....	72

## SUBJECT REFERENCE INDEX

<b>ANTENNAS</b>		Color TV grey scale .....	24
Dipoles, computing		“Dogs”—case histories .....	38
resonant frequency .....	59	Grid blocking in IF .....	24
Impedance matching .....	60	Horizontal picture shifting .....	51
Lead-in and rotator cable .....	14-16	Interacting circuits .....	26
Theory of operation .....	10	Lamp with magnetized base .....	30
<b>AUDIO</b>		Motorboating .....	50
Columbia Model 583 hi-fi .....	61	Picture tube, testing in home .....	30
Equalization networks .....	20	Regeneration, symptoms	
Flat frequency response .....	20	and remedies .....	12
“Packaged” hi-fi console .....	62	Sound bars in picture .....	50
Preamplifier, tape .....	66	Tuner replacement .....	24
Tape sales aid .....	64	Vertical multivibrator .....	24
Tubes, “preferred” type .....	65	Voltage dividers .....	26
<b>BUSINESS</b>		<b>TEST EQUIPMENT</b>	
“Bait” service charge .....	22	Conductivity sensor .....	32
Planned obsolescence .....	22	Tube tester, self-service .....	70
Procrastination, overcoming .....	38	<b>THEORY</b>	
Shop business,		Antenna principles .....	10
discussing with wife .....	67	Automatic fine tuning .....	44
Thorough service job .....	22	Conductivity sensing .....	32
<b>CIRCUITS</b>		Oxidation-reduction potential .....	32
Automatic fine tuning .....	44	pH of chemical solutions .....	35
Noise inverter .....	50	Regeneration .....	12
<b>COMPONENTS and MATERIALS</b>		Sky and surface wave .....	54
New products .....	69-71	UHF channel frequencies .....	22
Wire and cable .....	14-16	<b>TUBES</b>	
<b>SERVICING</b>		“Preferred” hi-fi types .....	65
AGC, keyed .....	26	6AF4, improved design .....	69
Audio output tube			
used as B+ voltage divider .....	26		

USE HANDY CARD AT BACK TO ENTER YOUR SUBSCRIPTION

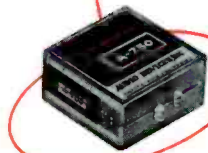

Single Pack



Full-wave Bridge



A-200  
Repair Kit



A-750 Repair Kit



Five Pack

THE

*Masterpieces...*

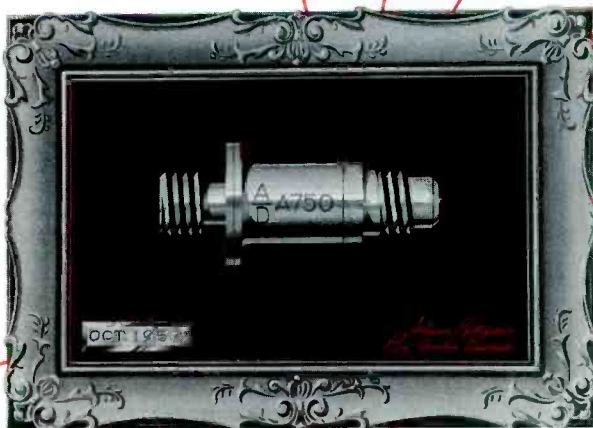

A complete universal line of  
Silicon Rectifier Repair Kits...to  
replace all Selenium Rectifiers  
in existing Radio / Television / and  
Electronic Devices

We invite you to see this universal screw-in/plug-in type  
Rectifier at your nearest distributor or write us direct  
for further information.



AUDIO DEVICES, INC. Rectifier Division

620 EAST DYER ROAD • SANTA ANA • CALIFORNIA

INQUIRE DEPT. RTW 1/11

# THE ASTRON "Staminized" STORY

ASTRON "Staminized" CAPACITORS ARE

## born--protected



ASTRON "Staminized" CAPACITORS ARE

ASTRON CORPORATION

ASTRON "Staminized" CAPACITORS ARE

## clearly marked



ASTRON CORPORATION

ASTRON "Staminized" CAPACITORS HAVE

## stability



ASTRON CORPORATION

ASTRON "Staminized" CAPACITORS ARE

## rugged



ASTRON CORPORATION

ASTRON "Staminized" CAPACITORS ARE

## moisture proof



ASTRON CORPORATION

ASTRON "Staminized" CAPACITORS HAVE

## long life



ASTRON CORPORATION

Here are the reasons why thousands of successful servicemen rely on ASTRON everyday to build and guard their reputations.

You've seen, read and heard about these advertisements many times during the past year. They have all told about Astron "Staminized" capacitors. Read them again and you will know you can rely on Astron everytime — no matter what job you tackle, there is an Astron "Staminized" capacitor built especially to fill the specific, exacting replacement requirement. Remember they're RUGGED, MOISTURE PROOF, CLEARLY MARKED, BORN PROTECTED and have LONG LIFE and STABILITY.

**ASTRON**  
CORPORATION



255 GRANT AVENUE  
EAST NEWARK, NEW JERSEY

Remember, your reputation is our business. Build it, guard it, protect it --- buy Astron capacitors, they're "staminized."

Export Division: Roche International Corp., 13 East 40th St., N. Y., N. Y. In Canada: Charles W. Pointon, 6 Alcina Ave., Toronto 10, Ontario

# Sylvania IF Amplifier Tubes



“fixed-bias” tested

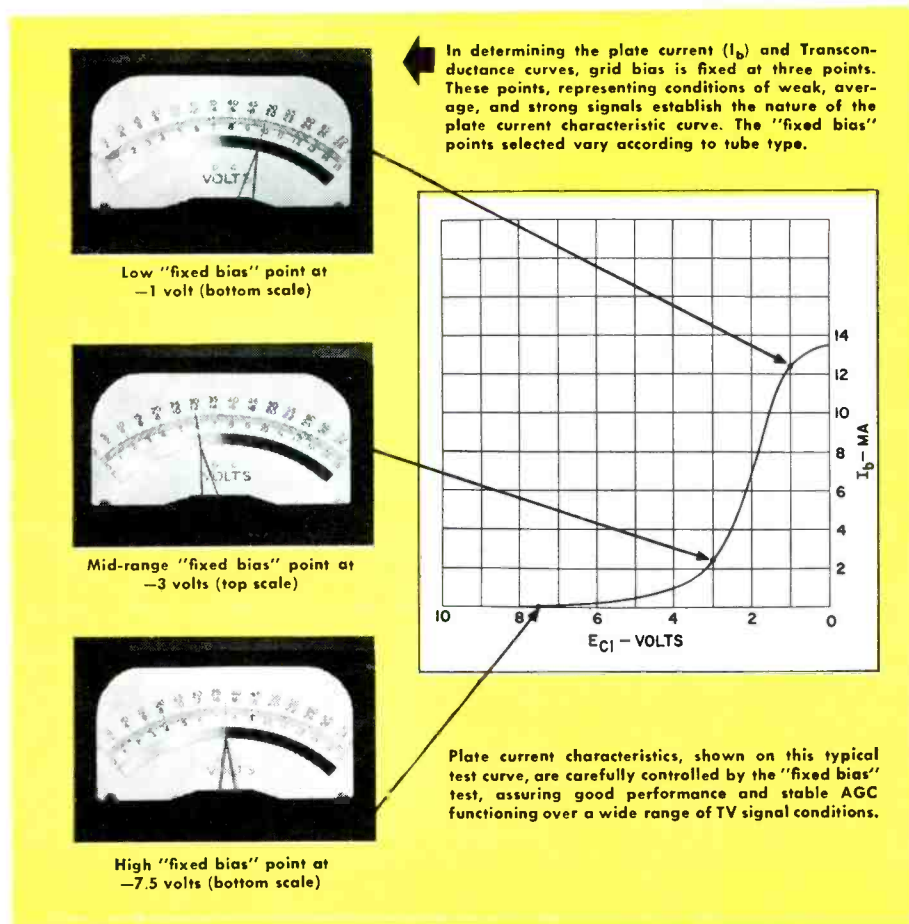

Dynamic TV set conditions are set up in these test bridges making the “fixed bias” test a true measure of how the tube will perform in TV sets encountered by you in the field.





## for stable performance and service dependability

IT HAS always been Sylvania's policy to search for new and better ways to test tubes under dynamic conditions for closer control over performance. The "fixed bias" test is typical of these techniques. It places a more stringent, realistic measure on the tube's ability to perform under varying circuit conditions.

By controlling the plate current characteristics and transconductance of IF amplifier tubes, the "fixed bias" test gives the serviceman an extra measure of dependability regardless of make, model, or age of the TV set serviced.

The range of stable operation is controlled, too, for smooth AGC action over wide variations in signal strength.

These are the same reasons that Sylvania IF types are the choice of leading TV set manufacturers, attested by the wide assortment of Sylvania original types listed among IF tubes now in popular use.

In addition to the "fixed bias" test many other electrical tests are performed on Sylvania IF amplifier types including stability during life. During life tests, close controls are placed on interelectrode leakage.

In every way, Sylvania IF amplifier types offer you maximum assurance of trouble-free service based on sound, newly developed testing methods. Specify Sylvania IF amplifier tubes in the new yellow and black carton.

 **SYLVANIA**

SYLVANIA ELECTRIC PRODUCTS INC.  
1740 Broadway, New York 17, N. Y.  
In Canada: Sylvania Electric (Canada) Ltd.  
University Tower Bldg., Montreal

LIGHTING • RADIO • ELECTRONICS • TELEVISION • ATOMIC ENERGY

# TV SERVICEMEN EXTRA BUSINESS

SERVICING TRANSISTOR RADIOS



Transistor  
Radio Probe

CAN PAY FOR YOUR

**NEW KINGSTON  
ABSORPTION  
ANALYZER**

This amazing TV trouble-shooter which simplifies wave form analysis can now be used to double the profit potential of every service man.

With the aid of the new probe, the Kingston Absorption Analyzer makes the troublesome and time-consuming job of servicing transistor radios both simple and profitable.

## WHAT YOU CAN DO WITH THIS NEW PROBE:

- Trace signals from antenna to speaker through RF, IF and Audio stages.
- HEAR and SEE signals by means of the phone jack and CRT of the analyzer.
- Check transistors in live circuits.
- Isolate defective stages.
- Localize invisible breaks in printed circuits.
- Locate distortion.
- Make direct probe contacts without possibility of damaging transistors.

Added to the time saving and increased business possibilities of the Kingston Absorption Analyzer for TV servicing, the extra profits possible from transistor radio servicing make the Kingston Absorption Analyzer your best new equipment buy for 1958.

See the Kingston Absorption Analyzer and its new Transistor Radio Probe at your local parts distributor or write direct.

**KINGSTON**  
ELECTRONIC CORPORATION  
MEDFIELD, MASSACHUSETTS, U. S. A.

## Letters to the EDITOR

Dear Editor:

I like PF REPORTER very much, but the service hints are not easy to find; they're scattered too much throughout the book. Why don't you put them all in alphabetical order on pages at the front or back of the book, to tear out and put in a notebook? Then the information would be readily available without hunting through all the books for something you remember seeing.

ANONYMOUS

Corydon, Ind.

Coward! We wish you'd signed your name to your letter, so we could send a personal reply. To answer your question, we don't "scatter" service hints on purpose. Plenty of explanatory material is put in the spaces between them for the benefit of our many readers who want to understand TV servicing and not just use cut-and-dried hints as a mental crutch. We know that locating information in past issues can be a problem; thus we offer a Subject Reference Index for our readers' convenience. The latest edition, covering January through December, 1957, is now available free by writing the Editor, PF REPORTER, 2201 East 46th Street, Indianapolis, Indiana.—Editor

Dear Editor:

I am interested in building a remote-controlled automobile as a hobby. Where can I obtain schematics and pictorial diagrams for such a project?

RICHARD J. MILLER

Rock Island, Ill.

If you're referring to a full-size auto, we are staying off the freeway from now on! But if you have reference to a model, we suggest that you check the hobby shops in your area.—Editor

Dear Editor:

Where can I buy a scale to check the weight or pressure applied by the pickup arm of a record changer?

C. J. SPIEGEL

Bucyrus, Ohio

Your local electronic parts or hi-fi distributor should be able to supply you with a gram scale for this purpose.—Editor

Dear Editor:

In checking my tube stock against your page of "Stock Guide for TV Tubes," I notice you make separate listings of 5U4G, 5U4GA, and 5U4GB. It is my understanding that a 5U4GB is the latest design of this tube type and can always be used where the other designations are called for. Regardless of which number I put on my orders,

my distributor always supplies 5U4GB's and I always use them satisfactorily.

The above is an example. You do the same thing with other tubes in the list such as 6BQ6, 12B4, 6SN7, etc. WHY?

COPELAND MACALLISTER

Framingham, Mass.

We asked ourselves the same question about a year ago. As a result, we no longer make these separate listings, as you will observe when studying the most recent Stock Guides.

We are conservative about combining similar types of horizontal output tubes, because of both physical and electrical considerations. The newer types such as 6DQ6 are sometimes too large for use in portable TV sets; in addition, they can be too "hot" for older receivers and may cause undesirable effects such as overscan.—Editor

Dear Editor:

In regard to the preamp circuit shown in Fig. 3, page 25 of the June, 1955 PF REPORTER, please advise pin connection for the first-section wiper on the equalization selector switch. (As shown, it has no connection.) This information is needed to complete the preamp.

Other equalization networks such as those specifically designed for European 78 rpm are contemplated and additional switch positions have been incorporated. Should you have any such networks worked out, this additional information would be very much appreciated.

S. B. DAVIDSON

Livingston, N. J.

Consulting Editor Bob Dunham, who developed this unit, says that the first-section wiper should be connected to the junction of R16 and R20. He also advises that R34 should be 47 ohms instead of 47K as shown.

Since these equalization circuits were developed by the cut-and-try method, and the three equalization positions come very near to the characteristics, European 78 rpm records could be played on the "78" position and further compensated with the bass and treble controls. Furthermore, all LP records can be played on either the RIAA or AES equalization settings and the correct playback curve obtained by adjustment of the bass and treble controls.—Editor

Dear Editor:

My partner and I could use to very good advantage a copy of your Tube Substitution Guide in our respective caddies (if, as we hope, you still have them available.)

ROBERT B. WORKMAN

Arlington, Va.

Lucky you! We have about 2 dozen on hand, so two copies are being forwarded to you with our compliments. We suspect that designers of new tube types are still working on three shifts, six days a week, but we are planning to catch up with them before too long. Watch for a revised Guide in the near future.—Editor

PF REPORTER · February, 1958

Mr. Service Dealer:



Helps you to maintain a profitable, **INDEPENDENT** position in the Servicing Industry



Raytheon makes available to you all the Technical Data, Shop Helps, Signs, Sales Builders, and Advertising Aids you need for a successful TV-Radio Service operation. This, plus a most complete line of finest quality TV and Radio Tubes, makes Raytheon first choice of Independent Service Dealers.

**NEW!**

1958 Edition of the Raytheon Receiving Tube Data book. 1000 types — 600 individual basing diagrams — all you need to know about Receiving Tubes.

**DISPLAYS**



**Displays** — Counter, Window, Transparent Banners, and Window Streamers, Decals.

**SHOP AIDS**



**Shop Aids** — Clocks, Tape and Dispensers, Stationery, Uniforms, Matches, Job Repair Tags, Tube Carrying Cases, Labels and Holders, Rubber Stamps and Pads, Drop Cloths, TV Screen Polishing Cloths, Tube Shelf Labels, Phone Call Registers, Triplicate Invoice Sets and Pocket Cases.

All these profit building items are available through your Raytheon Tube Distributor. Ask him for a free copy of Raytheon Business Builders booklet that describes them in detail.



**RAYTHEON MANUFACTURING COMPANY**

Receiving and Cathode Ray Tube Operations

NEWTON 58, MASS.      CHICAGO, ILL.      ATLANTA 6, GA.      LOS ANGELES 7, CALIF.  
55 Chapel Street      9501 Grand Ave. (Franklin Park)      1150 Zonolite Rd. N.E.      2419 So. Grand Ave.

Raytheon makes all these } Receiving and Picture Tubes, Reliable Subminiature and Miniature Tubes, Semiconductor Diodes and Transistors, Nucleonic Tubes, Microwave Tubes.

**TECHNICAL DATA**



**Technical Data** — Receiving Tube Data Book; Semiconductor Products Books; Picture Tube Books.

**SIGNS**

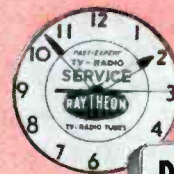

**Signs** — Indoor, outdoor, illuminated, metal, thermometers, "Will Return" Signs.

**ADVERTISING HELPS**



**Advertising Helps** — Advertising Mats and Post Card Mailers — Television and Radio Spots, Dummy Tube Cartons, Door Knob Hangers.



# ShopTalk

MILTON S. KIVER

Author of . . .  
*How to Understand and Use TV Test Instruments  
 and Analyzing and Tracing TV Circuits*

## Basic Antenna Principles

The most important adjunct to a television receiver is its antenna. Without an antenna of some sort, there isn't a set on the market today that will perform satisfactorily. In short, every receiver needs some external device to provide it with the necessary signal. This device may range all the way from a simple pair of rods on the back of the receiver to a multielement array mounted on a 100' tower.

The operation of an antenna is not as readily understood as the operation of a coil and capacitor combination ordinarily found in a tuned circuit; and yet, both systems operate in basically the same fashion. That is, an antenna is a device consisting of inductance, capacitance and resistance which are present in distributed form, while the coil, capacitor and resistor of a conventional tuning circuit exist, for the most part, as separate, individual units which we can see and feel. As a matter of fact, even this difference of form between the two systems disappears when we come to UHF tuning cavities. Here, as in antennas, it is not possible to point specifically to individual capacitances and inductances. The two are inseparably combined and we are forced to deal with them together, or not at all.

Since an antenna has the properties of inductance and capacitance, it will respond to the same type of signal as the front-end tuning circuits in the receiver. In the set, the signal reaches the tuning circuits from a prior circuit. At the receiving antenna, the prior circuit is the broadcast antenna, and the two are linked by

the electromagnetic energy existing between them. In other words, a certain amount of coupling is present between the receiving and broadcast antennas, and like two circuits that are coupled together, the transfer of energy that takes place depends on their relative positions. That is the reason television antennas are positioned with their rods held in a horizontal manner. The broadcast antenna sends out horizontally polarized signals and these are best received with a horizontally mounted antenna.

The signal that the broadcast antenna radiates consists entirely of electromagnetic waves which divide their energy equally between electric and magnetic fields. In free space the fields are at right angles to each other, and if we were to visualize them, they would appear as shown in Fig. 1. The fields represent the wave, the arrows the directions in which the forces are acting. The direction of travel of such a wave is always at right angles to both the electric and magnetic lines of force. Thus, if the lines of the electric field are vertical, and those of the magnetic field are horizontal, the wave travels forward.

To produce a pattern such as that shown in Fig. 1, it is necessary to position the radiating rods of the transmitting antenna vertically. The electric lines of force then represent the potential difference between the ends of the antenna; i.e., the e.m.f. that produces a current flow through the antenna rods. This current generates the magnetic lines of force which form around each rod at right angles to it. (In essence, this is no different than applying an

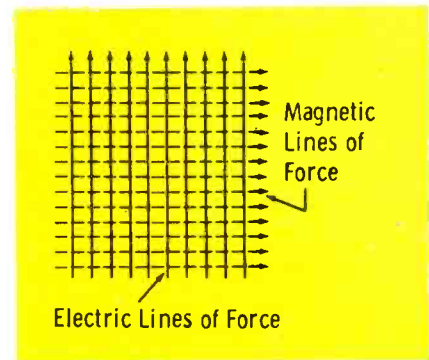

Fig. 1. Directions of electric and magnetic fields of an electromagnetic wave.

e.m.f. across the ends of a straight wire. The electric field of the battery would extend along the wire, causing current to flow, and the latter would create a surrounding magnetic field which was at right angles to the wire and hence to the applied e.m.f.)

The polarization of an antenna is, by definition, taken to be the same as that of its electric field. The field pattern in Fig. 1 is thus due to a vertically held antenna and the polarization is vertical. A horizontal antenna radiates a horizontally polarized wave. Maximum signal will be induced in the receiving antenna when its polarization is the same as that of the transmitting array.

## Radio Wave Travel

Radio waves radiated by an antenna may follow one of two general paths to reach the receiver and are classified either as ground waves or sky waves, depending on the path they travel. Ground waves are those which either travel close to the ground or else are actually guided by the ground. Sky waves are those which travel away from the earth for distances as great as 250 miles before they are bent sufficiently to enable them to return to earth. Although there is essentially only one mode for sky wave transmission, ground waves may be subclassified into surface waves, direct waves and ground reflected waves.

## Surface Waves

Propagation at low frequencies is accomplished principally through the use of the surface wave which travels in contact with the ground, actually being guided by it. The wave must be vertically polarized

• Please turn to page 54

**NEW  
COMPLETE**

**DIRECT  
VIEWING**





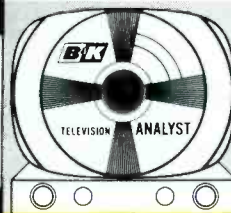
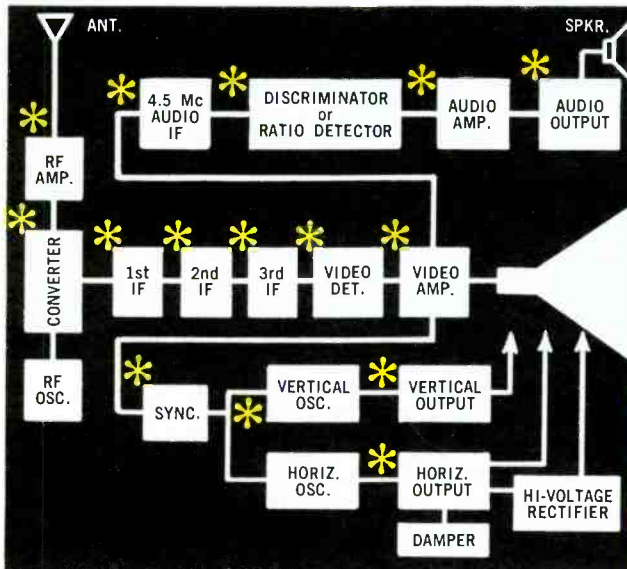

# TELEVISION ANALYST

**test each stage  
SEPARATELY**



and watch the  
← result on the  
TV set itself

**UNIQUE NEW SIGNAL-INJECTION TECHNIQUE  
Saves TV Trouble-Shooting Time and Work**

-  **R.F.** Supplies complete r.f. and i.f. signals with video and audio modulation to quickly trouble-shoot each stage in each of the sections of the TV receiver. Enables you to check the r.f. sensitivity and AGC settings of TV receivers.
-  **VIDEO** Reproduces a complete test pattern on the screen of the TV picture tube and injects signals into each video stage of the TV receiver for fast, visual trouble-shooting and correction—anywhere, anytime. Makes it easy to check bandwidth, resolution, shading and contrast capabilities of the TV set.
-  **SYNC** Provides composite signal, sync positive and negative.
- SWEEP CIRCUIT DRIVING PULSES** Provides separate vertical and horizontal driving pulses for trouble-shooting deflection circuits.
- INTERMITTENTS** Test signal injection also aids in locating intermittent troubles.
-  **AUDIO** Provides a 4.5 mc sound channel, FM modulated with approximately 25 kc deviation. (This audio carrier is modulated either from a built-in 400 cycle tone generator, or from your own external audio source.) Injection of the 400 cycle tone signal simplifies trouble-shooting of the audio section.
-  **COLOR** Enables you to trouble-shoot and signal trace color circuits in color TV sets.
  - 
  - Generates white dot and crosshatch patterns on the TV screen for color TV convergence adjustments.
  - Generates full color rainbow pattern of orange, red, magenta, blue, cyan, green to test color sync circuits, check range of hue control, align color demodulators, etc.
-  **SET ADJUSTMENT** Enables you to check and adjust the vertical and horizontal linearity, size and aspect ratio of television receivers.

**NEW**



**MODEL  
1075**



**QUICK, DIRECT, COMPLETE TV TROUBLE-SHOOTING**

Now, by point-to-point signal injection and test pattern reproduction, you can easily trouble-shoot and signal trace *any stage throughout the video, audio and sweep sections* of black & white and color TV receivers. With the remarkable new Model 1075 B&K TELEVISION ANALYST, you can quickly isolate and diagnose TV troubles (including intermittents). By use of the generated test pattern, you can *actually see* the condition directly on the picture tube of the television set itself. No external scope is needed. The TELEVISION ANALYST is practically a *complete TV service shop in one instrument!* Net, \$259<sup>95</sup>



See your B&K Distributor or write for Bulletin 1075-R

**B & K MANUFACTURING CO.**  
3726 N. Southport Ave. • Chicago 13, Illinois

Canada: Atlas Radio Corp., 50 Wingold, Toronto 10, Ont.

Export: Empire Exporters, 458 Broadway, New York 13, U. S. A.

# REGENERATION

## How to recognize and isolate it.

by Robert G. Middleton

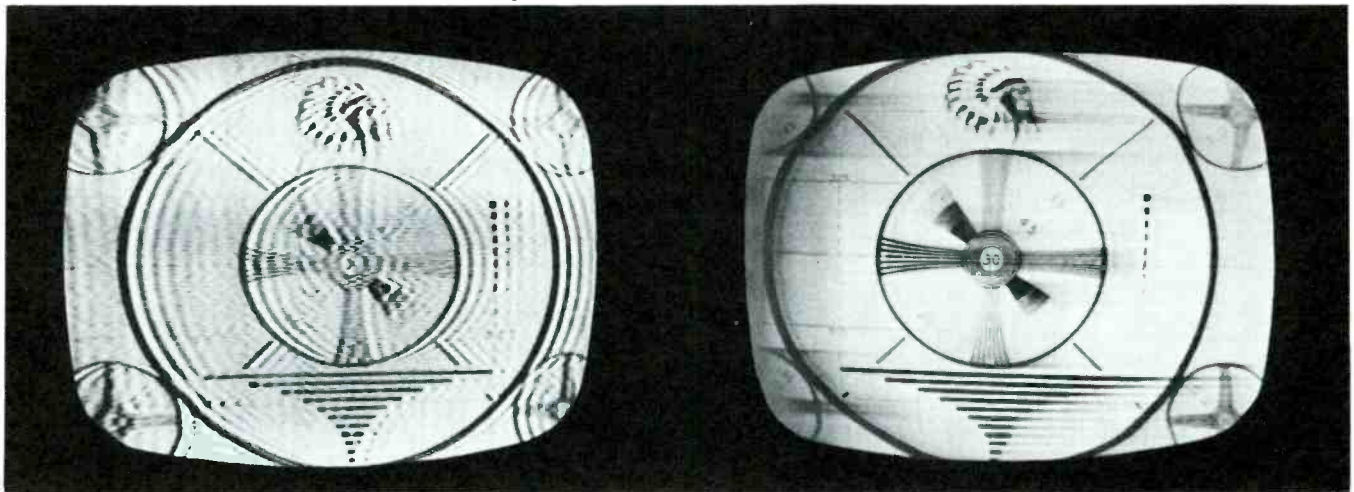

Fig. 1. Severe regeneration represented by multiple (ghost) images.

Fig. 2. Regeneration symptom shows up as picture smear and loss of detail.

Regeneration in the RF, IF and video circuits is often a serious problem at the service bench. In many instances, the difficulty of the problem is increased by lack of recognition of regeneration as the cause of the trouble symptom. This article will acquaint the service technician with the tell-tale symptoms, as well as how to locate and correct the cause of the trouble.

Like most other problems in TV troubleshooting, it is not the extreme cases that cause the most trouble. When regeneration is severe, as indicated by the symptom pictured in Fig. 1, the trouble is so apparent that localization becomes simplified. But when regeneration is just sufficient to cause trouble without producing violent symptoms, the technician's job becomes more difficult because there is considerably more margin for confusion in the interpretation of the circuit action. (See the typical trouble symptom of Fig. 2.)

Regeneration should always be suspected when there is separation of sound and picture on weak signals, critical adjustment of the fine tuning control and appearance of RF interference on some channels. Other symptoms of regeneration in television receiver circuits are: violent hissing from the audio channel when the sta-

tion selector is tuned to a vacant channel; distorted or weak sound on active channels; a hazy picture accompanied by ghosts. These symptoms usually are at a minimum during strong signal reception and are most troublesome under weak signal conditions when amplifier gain is maximum.

The violent hissing which sometimes accompanies regeneration is caused by the introduction of CW voltage into the receiver circuits from a regenerative loop which breaks into weak oscillation when no signal is being received. The CW voltage is modulated by atmospheric and circuit noises which are always present. They are then demodulated through the video detector and pass into the audio channel as a loud hiss.

When the technician encounters one or more of the aforementioned trouble symptoms, he will usually

check over-all alignment of the receiver. In doing so, however, he may become rather confused by the strange indications on the scope screen. Chief of these difficulties is a response curve that never looks "quite right"—no matter how carefully the alignment is performed—and which becomes very poor during weak signal reception. It is in situations of this sort that the technique of regenerative signal tracing finds its most valuable applications.

A comparison between a normal IF response curve and one which is distorted by the presence of regeneration is given in Fig. 3. The chief characteristic of the regenerative voltage is the appearance of a very sharply peaked response in some portion of the passband. The regenerative peak seen in Fig. 3 appears dim because the scope beam is rapidly travel-

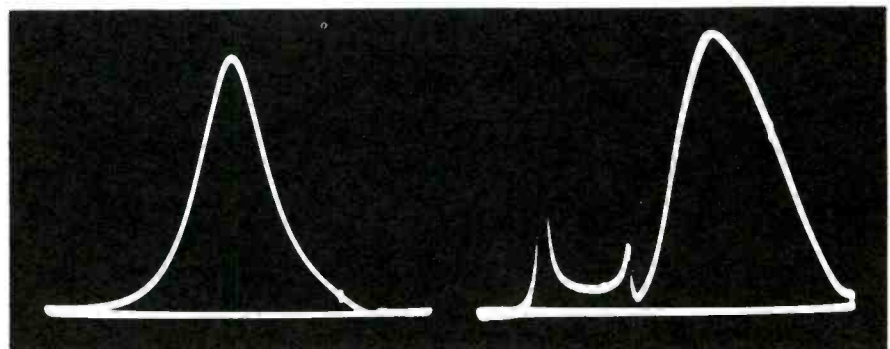

Fig. 3. Normal IF response curve; abnormal curve with regenerative distortion.

ing up and down the sharp peak, and the beam does not have time to fully energize the phosphor screen. When regeneration is very severe and the IF amplifier is on the verge of breaking into oscillation, the regenerative peak may be the only visible response (see Fig. 4).

When regeneration is so severe that an amplifier or chain of amplifiers breaks into oscillation, only the base line may remain visible on the scope screen and a VTVM might indicate 30 to 50 volts DC across the video detector load resistor. If a DC scope is being used, the resting position of the trace may be deflected off the screen and usually cannot be brought back into view by means of the vertical centering control.

Regeneration can be traced with almost any type of modulated IF or RF signal, but by far the most useful instrument for this purpose is a sweep-frequency generator, for it will show at a glance what is happening over the entire pass-band of the circuit or system under investigation.

Two commonly used methods of applying a sweep signal for regenerative signal-tracing tests are shown in Fig. 5. The principle involved consists of loosely coupling the sweep signal to the last IF stage so that the regenerative signal (if present) can proceed through to the video detector and make its contribution to the shape and height of the scope pattern. This principle is illustrated in Fig. 6. When making regenerative signal-tracing tests, it is usually advisable to begin with the video detector stage, since it receives the largest signal present in the entire IF strip and hence has the greatest opportunity to feed back

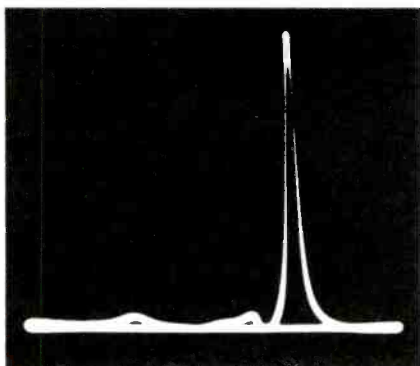

Fig. 4. When severe, the regenerative peak may predominate the display.

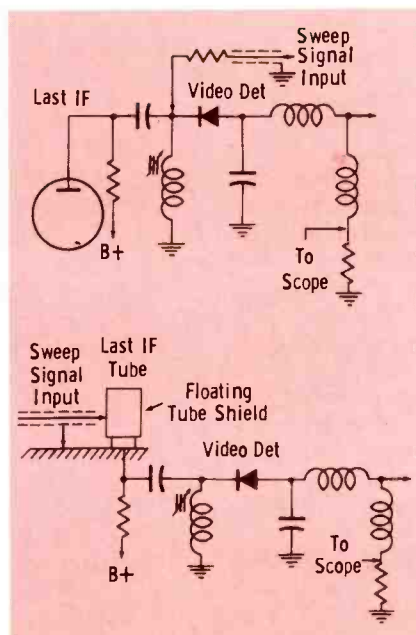

Fig. 5. Two suitable methods of applying a sweep signal for signal-tracing.

a portion of its energy to a preceding stage. Furthermore, the IF signal is normally clipped in the process of detection, and this clipping generates numerous harmonics known as "tweets," which are sometimes fed back to RF circuits where they cause RF regeneration as well.

In making the connections noted in Fig. 5, the sweep signal should be localized to the signal-injection point and not permitted to "spray" about the chassis. In addition, exposed generator leads should be kept very short. It is preferable to inject from the top of the chassis via a floating tube shield, using grounded tube shields over adjacent tubes that might pick up a signal from the exposed generator leads or clips.

When using the arrangement shown in Fig. 6, the pattern appearing on the scope screen is the response of the video detector cir-

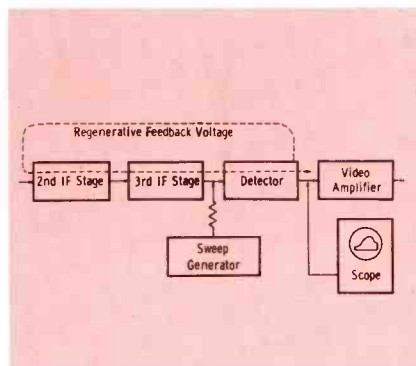

Fig. 6. A regenerative signal is part of desired signal that finds its way back to an earlier stage and is reamplified.

cuit plus any regenerative signal that may be present. To determine if a regenerative signal component is distorting the response curve, the technician can use a bypass capacitor to shunt the grid of any tube preceding the signal injection point to ground. This bypass capacitor obviously will "kill" any regenerative signal at that point and thus prevent it from progressing further through the IF amplifier circuits. When the regenerative component of the total signal is "killed," the operator will note a change in shape and/or height of the response curve. He then knows that he is operating within the regenerative signal loop. By continuing to work back from the signal-injection point, applying the bypass capacitor from grid to ground of successive tubes, he will eventually pass out of the regenerative loop. The signal-tracing job will then be completed, and the regenerative signal loop clearly mapped out.

Of course, the same technique can be applied anywhere in the receiver. A number of TV receivers in the lower price class were recently found to be subject to sound IF regeneration. When a 4.5-mc sweep signal was injected into a floating tube shield over the ratio-detector driver and a bypass capacitor shunted from grid to ground at the video-amplifier stage, a change in shape and height of the S-curve response was noted. Similar results were obtained by working back through the IF amplifier strip. It was finally determined that there was stray coupling between the sound system and the first video IF stage due to the physical proximity in chassis layout and insufficient shielding.

Common failures of components in both IF systems giving rise to the occurrence of regenerative signals are: open heater bypass capacitors; open AGC-bypass capacitors (or open delay capacitor); open screen-bypass capacitors; open plate-decoupling capacitors; mashed or shorted heater chokes; required wiring or tube shields missing; open IF damping resistors; incorrect peak alignment frequencies; mistuned traps; or use of an incorrect IF tube type having excessively high Gm. ▲

General Use  
Low Capacity  
(25mmf per ft.)

Lapel Mikes  
(34mmf per ft.)



### INTRODUCTION

*Like so many things that we use day in and day out, we seldom stop to think of wire as an important component—but what would the electronic age be without it?*

*Ask for a piece of wire at your parts house and you'll probably get the answer, "What kind of wire? We stock all sizes, shapes, styles and colors!"*

*To help you choose the right type of wire for various applications, this article describes the types normally available and explains their many uses.*

# WIRE AND

### Microphone Cable

Plastic covered "mike" cables are generally employed for hand-held and lapel mikes because of their small diameter. Many other types of cables are available, so be sure to pick the one best suited for the application. Watch the capacity/foot rating—the smaller cable has a higher capacity and its frequency characteristic may not match your "mike."

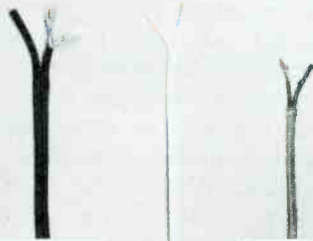

Extension Cords  
Heavy Duty  
Rip Strip

Standard  
Rip Strip

Decorative Use  
Cotton Covered  
Lamp Cord

### AC and Lamp Cord

Only three of the many types, sizes and styles are shown. The standard rip-strip is useful for short extension cords, lamps and small appliances. Heavy duty types are best for longer extension cords and appliances requiring more than average power. The cotton-covered cord is available in different colors and is best suited for lamps.

Use in Dummy Ceilings,  
Conduit and Where Exposed  
Wire is Not Apt to Be Damaged  
Or Appearance Is No Problem

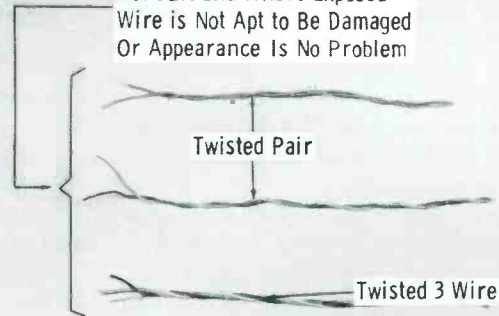

Cotton Covered  
Twisted Pair  
(Easily Painted Over)

### Bell and Speaker

Supplied in a wide variety of combination types—two-wire twisted and uncovered, three-wire twisted and uncovered, and two-wire twisted and covered being only a few. Always choose a size large enough to insure minimum losses of signal power when using as speaker wire or in any other audio applications.

Shielded  
100Ω Cable

Shielded  
300Ω Cable

Cellulose Filled 300Ω Tubular  
Twin Lead (UHF Special)

(Boosters, Police  
Radios and Other  
Special Uses)

Standard 300Ω Twin Lead  
(General Use)

Heavy Duty 300Ω Twin Lead  
(Use Where Extra Ruggedness  
is Called for)

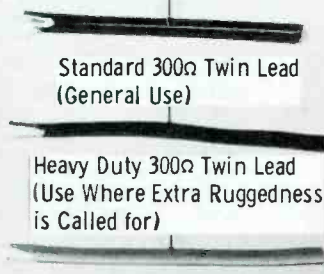

For Master Installations and  
Noisy Reception Areas

150Ω Twin Lead    75Ω Twin Lead

### Antenna Lead-In

Shielded types for noisy reception areas, 75- and 150-ohm for booster and special applications, cellulose filled for UHF and 300-ohm flat for standard TV antenna work. Terminals should be used at all connecting points to insure good contact.

### PA Connector Cable

Broadcast Audio Cable  
2 Conductor

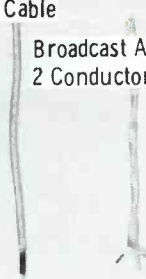

Useful Where Bare Outer  
Conductor Can Be Soldered  
to Metal Chassis At Various  
Points

### Shielded Cable (Noninsulated)

Useful where necessary to solder bond the shield to the chassis. Do not apply excessive heat at any point as damage to the inner insulation could result.



# ITS USES

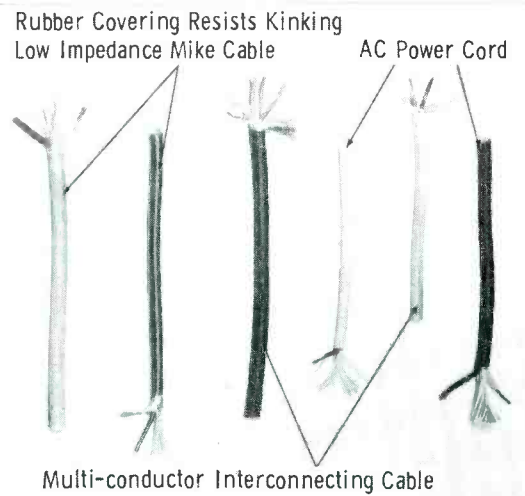

## Rubber-Covered Cable

Rubber-covered cables are preferred for portable use since they will take a lot of punishment and are more readily coiled for storage than plastic-covered equivalents. Rubber-covered "mike" cable is employed for use on stages because it stays put and is very flexible.

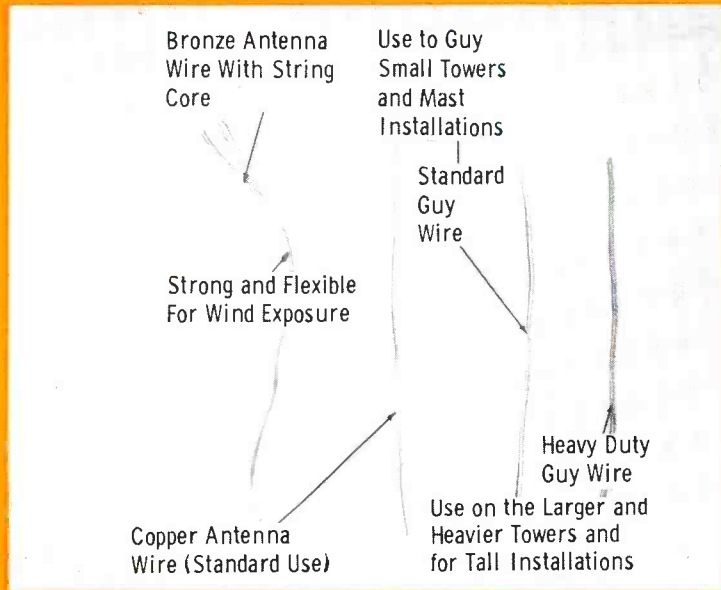

## Stranded Cable (Noninsulated)

Most familiar as antenna guy wire but also used for long wire antennas in AM receiver installations. In the latter application, bronze with string core provides a very strong, flexible wire for windy area installations.

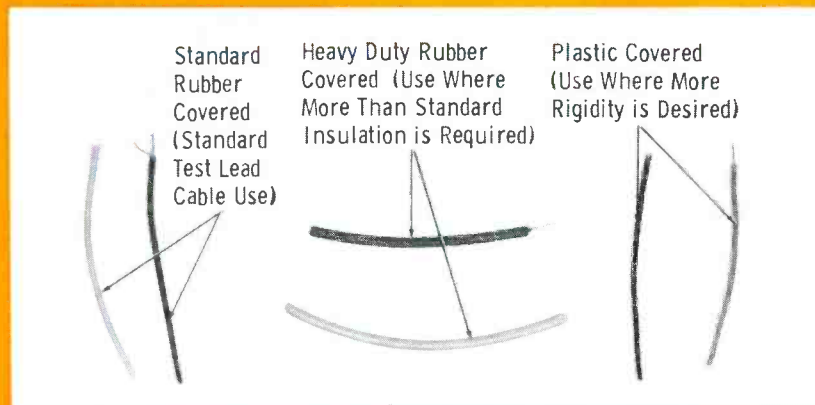

## Test Lead

Always stranded for great flexibility, test lead wire may be either plastic or rubber covered. Leads for all test instruments should be kept in good condition and free of insulation damage to avoid erroneous readings and preserve the professional appearance of the equipment.

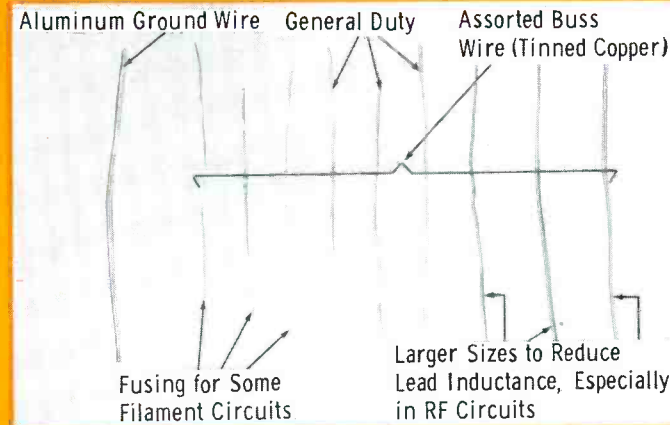

## Noninsulated Conductors

Supplied in both tinned copper (assorted sizes) and aluminum, the latter being the most often used by technicians. Always ground antenna systems for protection against lightning damage. Bus wire is useful for construction and special fuses where length and wire size are specified.



## Coaxial Transmission Cable

Although the RG59/U (73 ohms) and the RG58A/U (50 ohms) are most familiar to the service technician (used as 72-ohm TV antenna and signal generator leads, respectively), there are many different styles of coaxial cables employed in electronics. As a rule, "coax" is available with either a solid or stranded center conductor with essentially the same operating characteristics. Choose the stranded type if the cable will receive considerable flexing such as it would use as a signal generator cable.

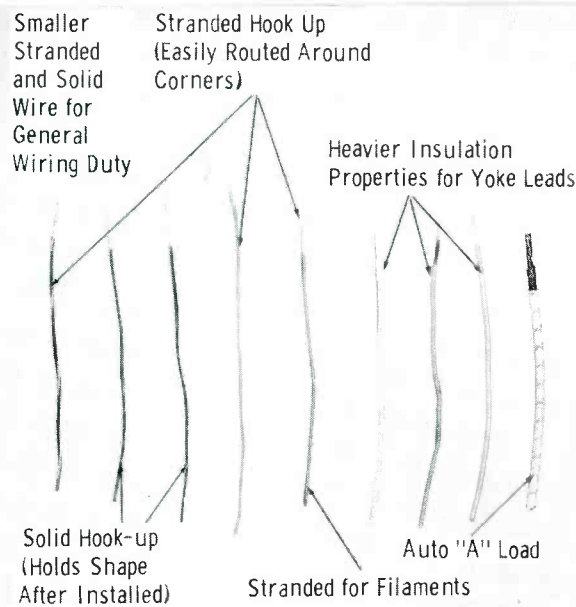

### Hookup Wire

Available in both solid and stranded types with a variety of insulating coverings. Select the correct wire size and insulation type for the job and avoid "spooky" troubles such as voltage drops in wire and arcing through insulation to metal chassis.

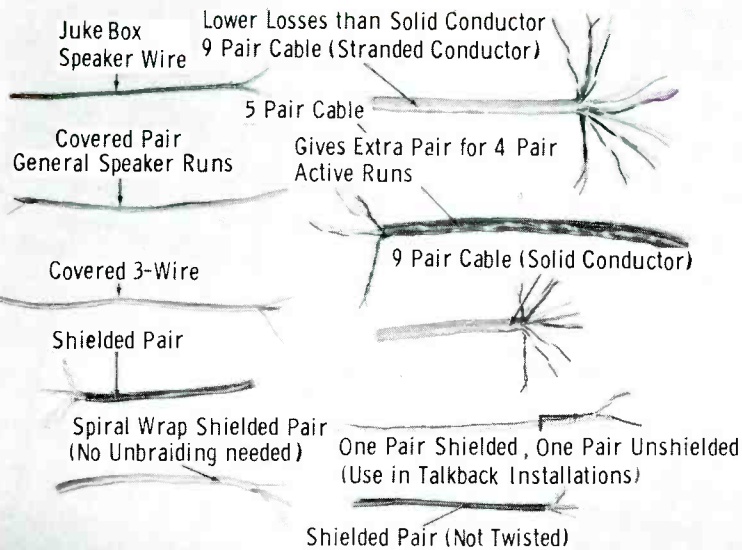

### Intercom Cable

A broad field that includes any wire or cable that is commonly used in connecting intercom and PA systems. Although only cables up to 9 pair are shown, intercom cable is available with up to 30 pairs standard and even more on special request. Wire size is variable, and both stranded and solid conductors are used. Always choose a type having more pairs than actually needed to provide for future expansion and alternates for wires that may become defective.

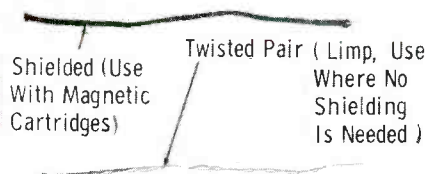

### Phono Cartridge

Choose either "limp" twisted pair or shielded pair for ceramic and crystal cartridges. Use only the shielded for magnetic cartridges.

10KV (Scope Wiring Small Sets)

20KV (HV Rect Filament Leads)

30KV (Most Anode Leads)

Extra Heavy Duty 40KV (Color Receivers and Other Exceptional Applications)

### High Voltage Cable

For replacement of filament and anode leads in high voltage TV circuits. Care should be used to avoid damaging the insulation in any way as this would severely affect the voltage rating of the wire. When soldering, use long nose pliers as a heat sink to prevent the insulation from melting.

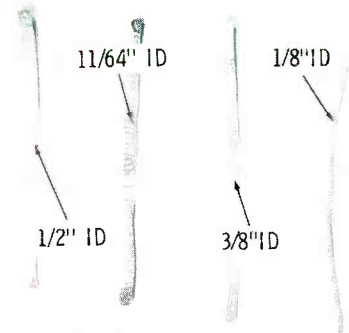

Use Flat For Bonding Strips Or Open Up To Act As Shielding For Another Wire

### Braid or Loom

Supplied in the flat form, but may be converted to loom or oval by pushing the ends toward each other and running a dowel of the ID size through the required length of braid. In braid form it is used for bonding and grounding straps. Use in the loom form to convert an unshielded cable to a shielded one.

(For Under Rug Use) 4 Conductors

(For Use with Light Position Indicator) Round, 8 Conductor

(Outside Cover Adds Strength for Long Runs) Round 4 Conductor

Round 5 Conductor (Some Automatic Models Require 5 Wires)

### Rotator Cable

Flat type features one tinned and three bare copper conductors. The tinned conductor is for sequence identification. Lightning arrestors are available for both styles and should be used unless the antenna mast assembly is grounded.

**FREE!** from **HOWARD W. SAMS...**  
 these valuable all-steel file cabinets with your purchase of  
**PHOTOFACT** *the world's finest TV-Radio Service Data*



**NOW—FOR PHOTOFACT**

**SUBSCRIBERS!** You can get these File Cabinets **ABSOLUTELY FREE** from Howard W. Sams if you are a regular subscriber to PHOTOFACT and buy each Set as issued monthly...

**NOW—FOR PHOTOFACT LIBRARY PURCHASERS!**

You can get **FREE** File Cabinets as you complete your PHOTOFACT Library. What's more, you can own the PHOTOFACT Library the **NEW EASY-BUY WAY:** There's no interest. There's no carrying charge. And Howard W. Sams will give you **ABSOLUTELY FREE** all the steel file cabinets you'll need for your Library.

Take advantage of this money-saving opportunity. See your Sams Distributor today, or write to Howard W. Sams for full details...



**HOWARD W. SAMS & CO., INC.**  
 2201 E. 46th St., Indianapolis 5, Indiana

- Send me full details on your FREE File cabinet offer and EASY-BUY Plan.
- I'm a Service Technician:  full time;  part time

My Distributor is: \_\_\_\_\_

Shop Name: \_\_\_\_\_

Attn.: \_\_\_\_\_

Address: \_\_\_\_\_

City \_\_\_\_\_ Zone \_\_\_\_\_ State \_\_\_\_\_

**FREE** file cabinets

**NEW** easy-buy plan



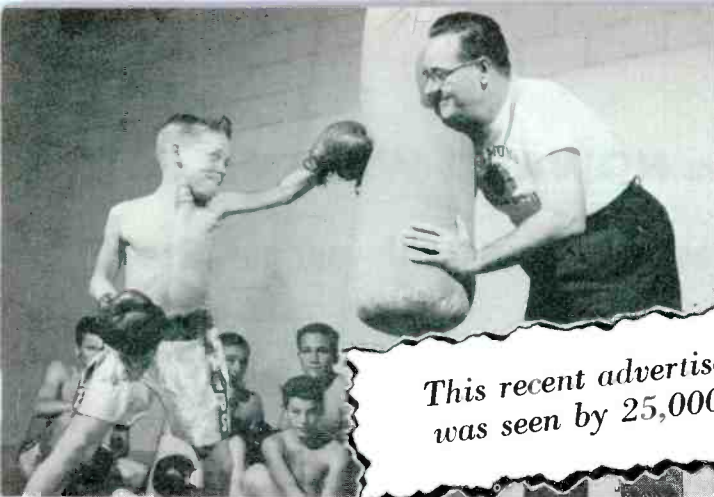

This recent advertisement in **LIFE** was seen by 25,000,000 people...

**GOOD SPORTSMANSHIP** is developed by Marcus E. Denham at Whitaker State Orphans' Home, Pryor, Oklahoma, where he assists in recreational activities. He is also prominent in many local community service groups. His work is typical of the many public service contributions of TV technicians everywhere.

**BOY SCOUT WORK** and assistance to Charlotte, Michigan, youth groups make Bart Rypstra, Jr., another "All-American". He is a member of the Charlotte city council, active in civil defense communications, and belongs to many community service clubs. When time permits, Bart devotes his technical talents to servicing sound equipment, movie projectors and record players at city schools.



**JUDGES SELECTED 13 WINNERS** to receive this trophy, \$500 for use in community improvement, and luncheon with Under Secretary of Commerce Walter Williams at Washington, D.C.

## "ALL-AMERICAN" TV TECHNICIANS WIN GENERAL ELECTRIC AWARDS FOR PUBLIC SERVICE

**A**MERICANS everywhere responded to General Electric's invitation to nominate candidates for "All-American" Awards, honoring television technicians who have distinguished themselves in public service.

The winners, whose pictures appear on these pages, were selected by a panel of judges composed of *Wendell Barnes*, Administrator, Small Business Administration; *Wendell Ford*, 1956-57 President, United States Junior Chamber of Commerce; *Herman Hickman*, Sports Authority; and *Ed Sullivan*, Columnist and TV Personality.

General Electric has established these awards as another step in its program to recognize the public service contributions made by independent businessmen everywhere.

The accomplishments of these television technicians should serve as an inspiration to all Americans. *General Electric Company, Receiving Tube Department, Owensboro, Kentucky.*

*Progress Is Our Most Important Product*

**GENERAL  ELECTRIC**

11-11-101

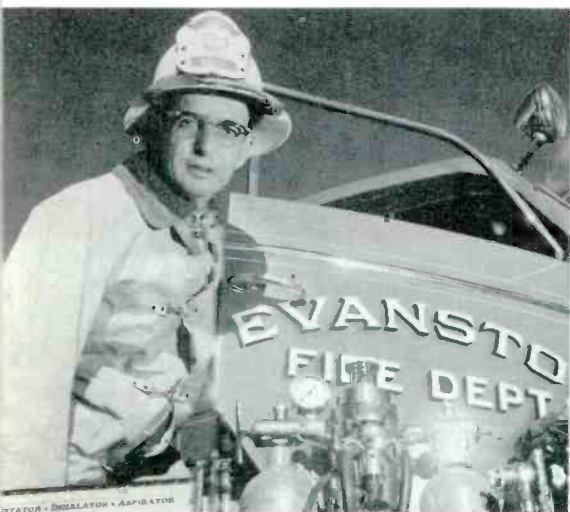

**VOLUNTEER FIREMAN** and Instructor John R. O'Brien, Evanston, Wyoming, teaches first aid at neighboring fire companies and schools. He is active in communications during civic emergencies, and lends and installs sound equipment for town functions. Many community service groups benefit from his time and skills.



**MANY WERE SAVED** by Scott Witcher, Jr., during Lampasas, Texas, disaster. Here he shows height of water in raging flood which swept his area. Scott saved lives and helped restore communications to the community. He is active in the National Guard, in civic and youth organizations.



**TV FOR THE SICK** is provided by Billy Joe Jenkins of Paducah, Texas. By installing antenna cable and servicing sets without charge, Billy Joe has made it possible for patients in Richards Memorial Hospital to enjoy TV. He helps community improvement drives, teaches electronics to Boy Scouts.



**GIRLS' DRILL TEAM** at St. Joseph's Parish is supported by Remo De Nicola, Quincy, Mass., as one of his many community services. He also gives free television service to a school for retarded children and is always ready to lend sound equipment for charitable affairs.



**CIVIL DEFENSE LEADER** Richard G. Wells, Jr., Pikeville, Ky., installed television cables from a community antenna to Pikeville College, high school, fire department, Scout building and Methodist Hospital. He is working to give the high school a closed-circuit TV system.



**FIVE PUBLIC SERVICE CITATIONS** plus a civilian Navy award were given Frank J. Hatler, Roselle, N. J., for his communications work in community emergencies. As local civil defense head, Frank organized communications networks, helped many to get radio licenses.



**BLIND CAN SKATE** because Philip G. Rehkopf, Jr., Louisville, Kentucky, installed a record player and placed loud speakers around the walls of the gymnasium at the Kentucky Home for the Blind. He developed an electronic device to give scores to blind basketball fans, and tape records text books for blind students.



**WHEEL CHAIR** is no handicap for Mortimer Libowitz of Brooklyn, New York. Though disabled all of his life, Morty has devoted his time to helping others in his community. With a crew of student volunteers, he maintains the radio station at Thomas Jefferson High School, Brooklyn. He also services a Red Cross radio station and is active in civil defense communications. Morty has trained many youths in radio, developing some into amateur operators and skilled television technicians.



**ELECTRONICS LABORATORY** at Long Beach City College, California, was established with help from Harry E. Ward. Harry serves as chairman of the Business and Technology Advisory Committee and for fifteen years has devoted his time to finding work for students, graduates and others.



**STUDENT BENEFACTOR** Philip T. Di Pace, of Albany, N. Y., contributes used radio and television chassis and parts to Siena College students who are interested in electronics. Phil now heads a project to finance an athletic field and playground for 75 neighborhood children.

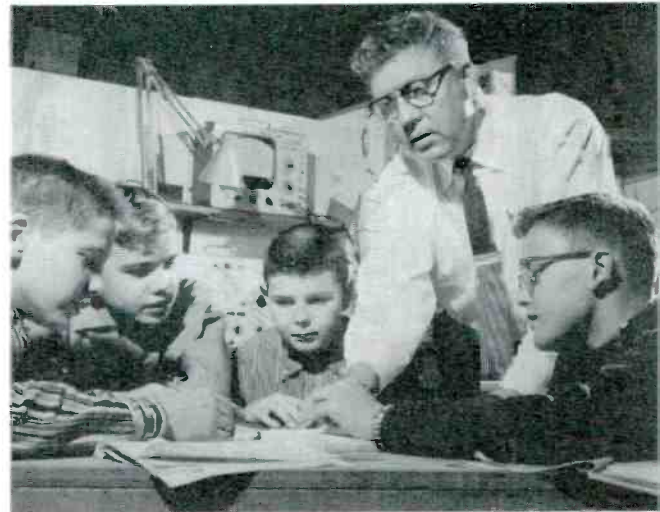

**BASIC ELECTRONICS** is taught to neighborhood boys by John H. Stefanski, Pontiac, Michigan. He has organized a scientific library for the boys and is now planning a new Pontiac Boy's Club. John has served as chairman of the Business Ethics Board of the Pontiac area Chamber of Commerce. Television sets in the Oakland County Sanatorium are serviced without charge through his efforts.

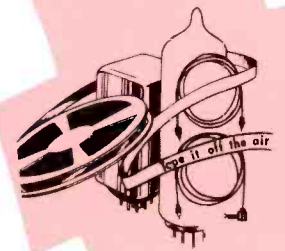
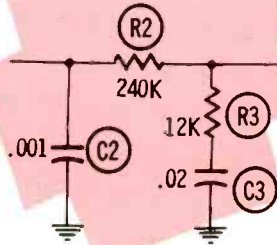

by Calvin C. Young, Jr.

## An Analysis of Equalization Networks

## Servicing the Columbia Packaged Hi-Fi

## Products for Profit

### Analyzing Equalization Networks

In a hi-fi system, it is generally desirable to have a frequency response which is flat over the entire audible range. This doesn't mean that every component (speaker, amplifiers, cartridge, etc.) will have a flat response, nor does it mean that corrective measures will be taken with respect to every unit to produce this desired response. It does mean, however, that action should be taken to insure that the output will be as nearly like the original music or sound as possible.

What do we mean by flat? Simply stated, a flat response is realized when, after adjusting the volume control to reproduce the original volume level at any frequency, the original volume level will be reproduced at all frequencies present on the recording. Now that we have established the need for a frequency response that

covers the entire audible range and that is flat, let's see how equalization and equalizers fit into the picture.

Those of you who are familiar with the specifications for playback power amplifiers know that a typical listing of these specs might be 30 watts of audio over the range of 20 cps to 50kc  $\pm 1.5$  db at less than 3% IM (intermodulation) distortion. You should also be familiar with the fact that a speaker enclosure is designed to load the speaker and thus match it to the output amplifier to produce an essentially flat frequency response. It is also readily accepted that we can design voltage amplifier stages with a flat frequency response over the entire audio range. Why, then, do we need equalization (frequency compensation)?

There are two main reasons—the pickup device used in the playback system and the recording itself.

Let's examine the recording first. Most pickup cartridges utilize the velocity principle wherein the output signal voltage is proportional to the excursion rate of the needle. It just so happens that when the record is cut to produce equal velocities for all frequencies of the same voltage amplitude, the excursion distance is inversely proportional to frequency.

In Fig. 1, two signals are superimposed to illustrate this phenomenon. This would mean (using practical figures) that if an excursion of  $\frac{1}{10,000}$  inch produced maximum output voltage at 20,000 cps, then the excursion to produce the same output at 20 cps would be  $\frac{1}{10}$  inch. It is easy to see that grooves  $\frac{1}{10}$  inch wide cannot possibly be packed 100 to the inch on a record. LP and extended play 45's sometimes have even more than 100 grooves-to-the-inch. For this reason, then, the amplitudes of low frequency signals are at-

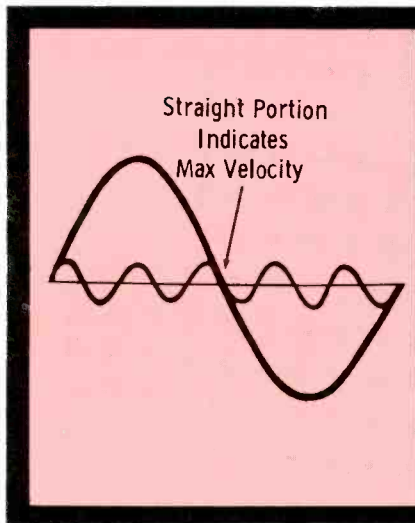

Fig. 1. Constant velocity at all frequencies results in higher amplitude at low frequencies.

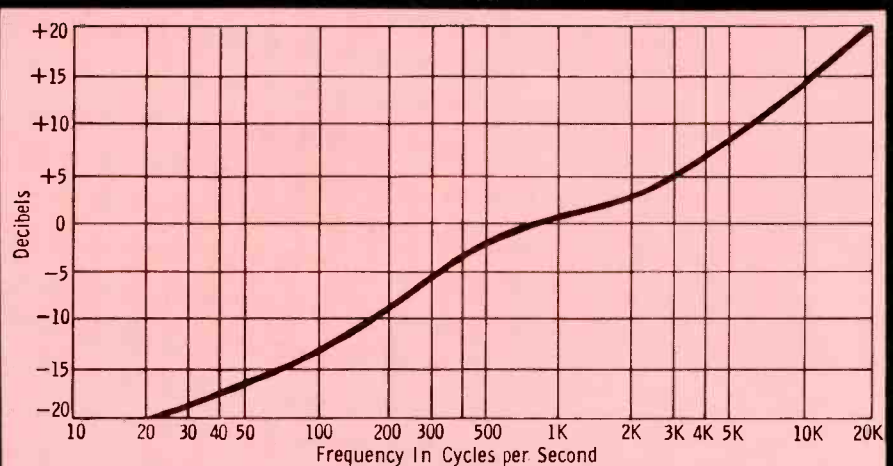

Fig. 2. RIAA recording curve ( $\pm 2$  db tolerance).

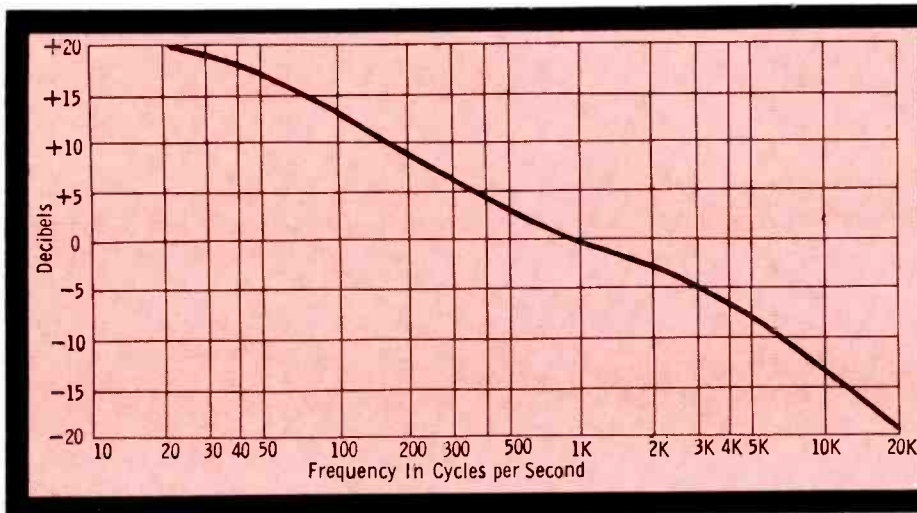

Fig. 3. RIAA playback curve ( $\pm 2$  db tolerance).

tenuated before applying them to the record.

On modern recordings, this is not done on a helter-skelter basis. Instead, most recordings are now made based on the RIAA (Recording Industry Association of America) curve shown in Fig. 2. As you can readily see, all signals with a frequency below 1,000 cps will be attenuated, while those above 1,000 cps will be boosted. Applying this information to your general knowledge of a playback system, you can see that if we are to listen to music as it sounded before being put on the record, some frequency compensation must be employed in the playback system. The RIAA playback curve in Fig. 3 is the reverse of the record curve in Fig. 2, and equalization in the playback must provide a boost

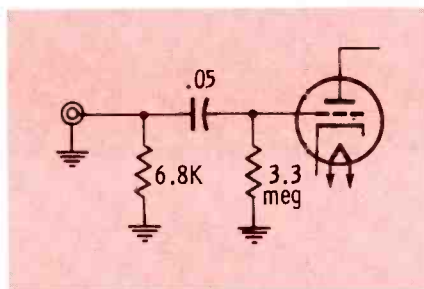

Fig. 5. Equalization in input circuit.

of the low frequencies and attenuation of the high frequencies in accordance with this curve to produce a flat response.

This, of course, assumes a flat response characteristic for the pickup device—a condition not always found. To compensate for the frequency-characteristic differences between the various pickup devices, tone controls that

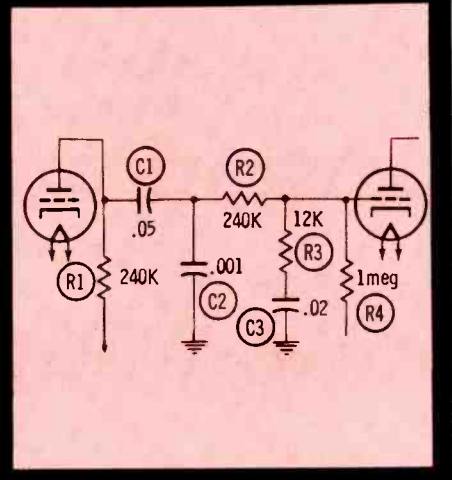

Fig. 4. Basic equalization circuit.

can provide either boost or attenuation of both low and high frequencies are included in playback systems, but generally, the ranges of these controls are not sufficient to complement the record curve. Thus, a special circuit that accomplishes the required equalization is incorporated in the playback amplifier and is almost always made up of combinations of resistors and capacitors. Let's examine the basic circuit shown in Fig. 4 and see how this combination of resistance and capacitance can be used for frequency correction.

First of all, let's eliminate the components which are not primarily tied in with frequency correction—the plate-load resistor for the 1st stage R1, the coupling ca-

*• Please turn to page 61*

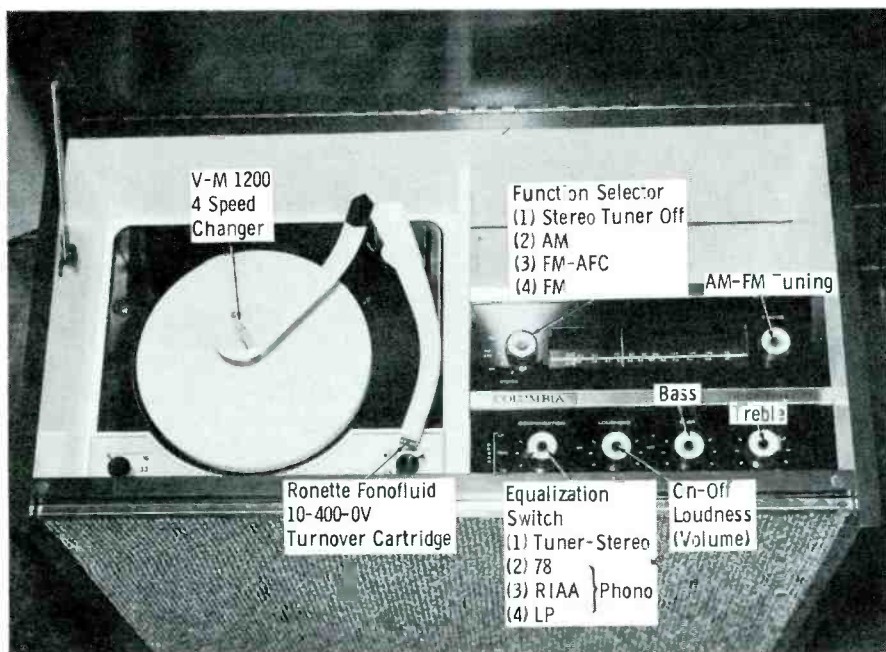

Fig. 6. Columbia Model 583 Packaged Hi-Fi.

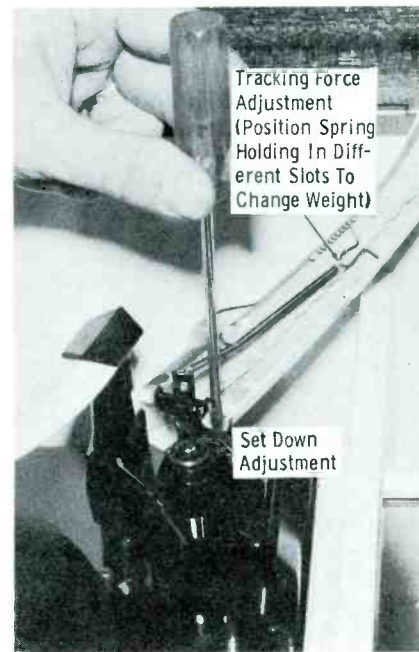

Fig. 7. Location of setdown and tracking force adjustments.



## DOLLAR & SENSE Servicing

**Beware Giveaways.** Ever thought of advertising some free item of merchandise as an inducement for customers to come into your shop? If so, better have plenty of the gimmicks on hand and be prepared to be trampled underfoot. You might have the same sad experience as a Milwaukee furniture store which tested the pulling power of its TV commercials by offering an \$8.95 lamp to every viewer who came to the store during a certain 2-hour period. A stampede of 8,000 people resulted, the riot squad was called out, and the store sank \$15,000 into enough lamps to make good on its offer. Increase in sales as a result of the promotion? Not worth mentioning.



**Boom.** Progress is not merely advancing, but is virtually exploding, says Dr. H. J. Rand, noted inventor and president of Rand Development Corp. Speaking before the American Management Assoc., he recently pointed out that even the most conservative estimates of future progress forecast a tremendous revolution in technology. According to Dr. Rand, the leaders in this revolution will be chemistry, plastics, metallurgy and electronics. He maintains that the "key" to this whole new era will be the electronic brain or computer, which increases by a thousandfold man's ability to solve difficult problems. In the year 2000, we can expect to see electronic brains controlled by preset instructions operating in nearly every factory, farm, government office, and school, and possibly even in the home.

He also predicts a great future for electronic equipment in the fields of automation and industrial TV. For example, farmers may someday control tractors from a central station, watching television

screens to guide their machines. From these predictions, it's easy to see that good service technicians in the home-entertainment and industrial fields will continue to be in great demand. Those who study continuously to keep pace with the field will be foremost, ready to take advantage of new opportunities and accept greater responsibilities.



**Joneses Please Note.** EIA (formerly RETMA) is planning an industry-wide advertising promotion to keep the public reminded of technical and styling improvements being made in new TV sets. This campaign is intended to give a boost to the "planned obsolescence" which has worked so well in the auto industry to keep sales of new models at a high level. If this pre-selling job attains its objectives, a TV service dealer may find it a lot easier to sell a new set than to collect \$25 to \$100 for patching up the old one.

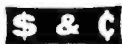

**Laid On the Line.** TV-Radio Lab, Hunter, N. Dak., gives its customers a choice of two classes of service which are itemized as follows in the shop's direct mail advertising:

I. THE ECONOMY JOB. The aim here is *rock-bottom cost*. Only the bare minimum in parts are used to put the set back into operation.

II. THE A-1 JOB. The aim here is a thorough check of the entire set. This job includes the following:

1. Removal of chassis.
2. Cleaning chassis and glass.
3. Testing all tubes (in a trans-conductance tester and checking for grid emission.)
4. Pre-heating new tubes.

5. Adjusting horizontal-vertical linearity and height control.
6. Checking ion trap and focus.
7. Test run for three hours.
8. Any other needed service.
9. 90-day guarantee.

How's this for letting the customer sell himself on a higher-priced but more satisfactory service job?



**Run Out of Bait.** "TSA News" (Michigan), reports the case of a customer who could not reach her regular serviceman (who charged \$3 per TV call) and rather reluctantly switched to a dealer whose fee was \$5 per call.

The technician replaced one tube and a fuse. He charged her 30¢ for the fuse, \$3.20 for the tube, and \$5 for the call, or a total of \$8.50. She remarked, "Gee, that tube has certainly dropped in price!" and the technician replied that tube prices had gone up, not down. At this point, the customer brought out a ticket that showed she had paid \$7.80 for the same tube the last time it had gone bad, plus \$3 for the home call, making a total of \$10.80 without a fuse. At the time she thought she had a bargain.

Guess who answered her next service call.



**Necessities of Life.** A modestly-priced TV set is the cheapest form of entertainment available to a family, and thus it is reasonable to consider it a necessary item of furniture. So ruled a municipal court judge in Washington, D. C., who refused to allow a creditor to proceed with attachment of a used TV for a bad debt.

If you sell used sets and handle the financing—beware! The law may leave you no recourse if the debtor can't pay.



**Rule of Thumb.** Consulting Editor George Mann has figured out a formula for finding UHF channel frequencies, which could come in handy if you're performing UHF tuner alignment and don't happen to have a frequency chart. Take the channel number, multiply by 6, and add 387.25 to get the picture carrier frequency in megacycles. For the sound carrier frequency, add another 4.5 mc.



**G-C-TELCO**

# **GOLDEN INVADER**

## The Antenna That Beats Them All!

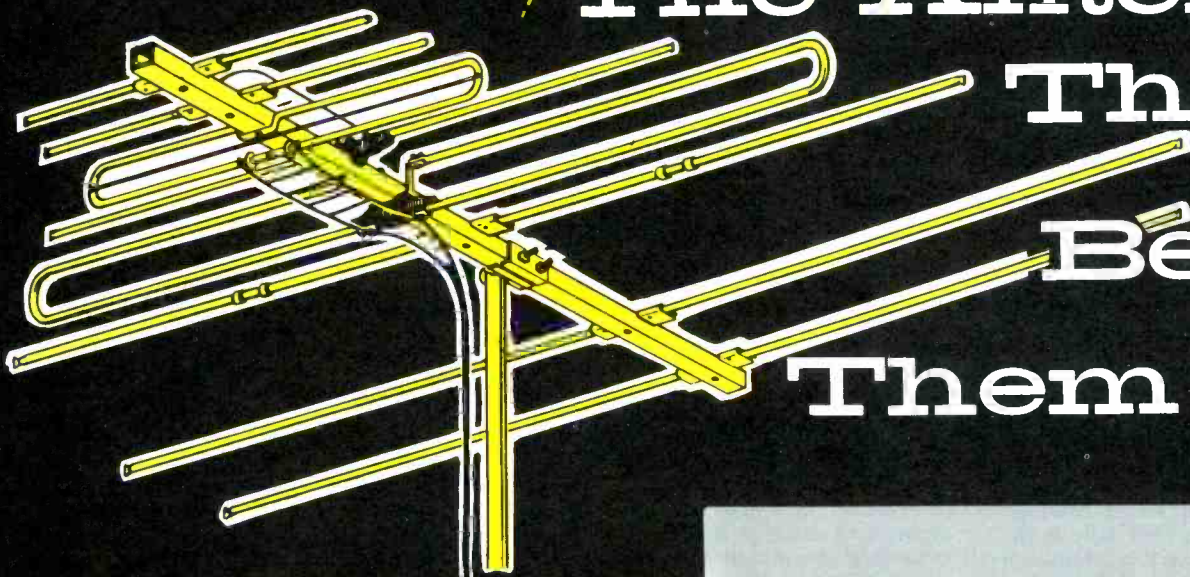

**TRY TELCO'S NEW GOLDEN INVADER**, the powerful antenna for VHF fringe areas and UHF primary areas. Extensive tests prove its uni-plane design can pull in stations from as far as 200 miles away. Ghosts and co-channel interference are eliminated. The **GOLDEN INVADER**, for color or black-and-white TV, comes pre-assembled with the new Snap-Lock construction that makes it easier to handle, easier to install. Available in single bay (illustrated), two-bay or four-bay models.

- SUPER SHARP DIRECTIVITY
- BEAUTIFUL GOLD ANODIZING
- NEW SNAP-LOCK DESIGN
- RECEPTION UP TO 200 MILES AWAY

**No. A-8121 Single Bay..... List \$29.95**  
**A-8122 Two-Bay..... 59.95**

### **VALUABLE BONUS FOR YOU!**

Enclosed with each TELCO GOLDEN INVADER is a special Golden Bonus Certificate. Look for these Certificates . . . save them. They're valuable to you!

### **UNCONDITIONAL GUARANTY...**

A Telco Exclusive! TELCO guarantees the **GOLDEN INVADER** and all Telco Antennas to be free from defects in materials and workmanship. This guarantee on the Golden Invader is for *three* years. All other antennas are guaranteed for one year.

**G-C-TELCO**

**TELCO ELECTRONICS MFG. CO.**

Division of G-C - Textron Inc. • Los Angeles 18, Cal. • Rockford, Ill., U.S.A.

### **THE COMPLETE LINE OF TELCO POWER PACKED ANTENNAS**

CONICALS

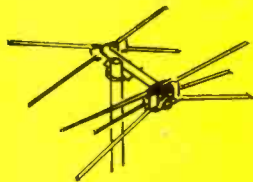

YAGIS

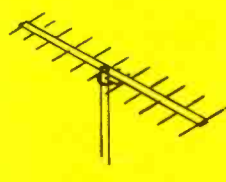

INLINES

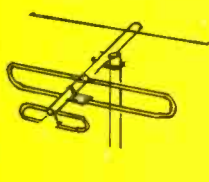

BOW TIES

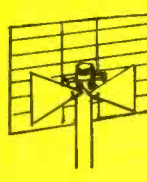

INDOORS

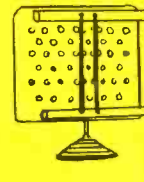

ANTENNA KITS

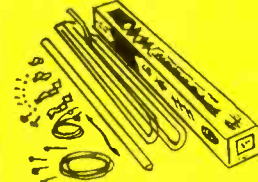

# the TROUBLESHOOTER

answers to  
readers'  
service  
problems



## IF Grid Blocking

Some time ago I encountered an Emerson Model 1155 with no picture or sound but with a good raster. After trying new RF and IF tubes, the trouble was not corrected, and so I took the set to my shop. I started to run a signal through the IF section, but as soon as I touched the grid of the first IF tube, the picture and sound returned to normal. The set operated daily in the shop for weeks without any trouble. It was returned to the owner, but I had to pick it up the next day with the same trouble. It is still not permanently corrected.

EDWARD JACOB

Metairie, La.

You have a negative charge building up on the grid of the first IF and blocking the stage. This charge is removed, and set operation is restored, whenever you touch the grid with a test probe. Something is evidently causing an intermittent open circuit in the DC return path from the first IF grid to ground. Two different versions of this circuit are found among receivers of this model run. When the grid return includes only the AGC line and video detector load (connected by dotted line on schematic), grid-to-ground resistance should read approximately 1 megohm. If the AGC voltage is obtained from a separate diode rectifier, more resistance is added; however, the ohmmeter reading from

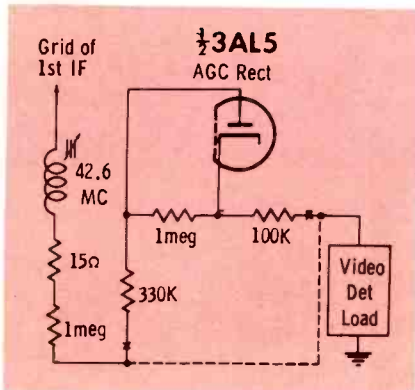

grid to ground should not exceed 2.5 megohms. In this low-voltage circuit, a very small gap such as a slightly loose resistor lead could cause an open condition.

## No Vertical Sweep

On my General Electric Model 14C102, there is no vertical deflection. I have determined that the multivibrator is inoperative and that R95, the plate load resistor of the output stage, is burning up as a result. I can inject a 60-cps signal through .1 mfd at the grid of the first section of the multivibrator and get deflection. Does this indicate that the multivibrator has to be pulsed in order to operate?

WESLEY KOROVLEV

Detroit, Mich.

The vertical output stage, which is also the second half of the multivibrator, consists of both sections of a 12AU7 in parallel. Apparently, these are conducting continuously and drawing excessive plate current as a result of the defect. The injected 60-cps signal might be pulsing the circuit into operation, but it is more likely that the multivibrator tubes are simply amplifying the signal and applying it to the yoke to produce deflection. The fact that the circuit will amplify does not prove that it will oscillate. The multivibrator should run without being pulsed in any case. In fact, you might find it easier to repair the vertical sweep circuit if you prevent it from being pulsed or otherwise affected by the sync stages. Temporarily disconnect the 470-mmf capacitor between the sync amplifier and multivibrator.

Sad to say, almost any component in the multivibrator can develop a defect which will cause the circuit to cease functioning; hence, the best troubleshooting aid is a thorough understanding of how the circuit operates. The G.E. circuit under discussion is very similar to "The Modern Vertical Sweep Circuit" described in our July, 1957 issue. Check through that description; it should give you some good hints.

## In Again, Out Again - Finnegan!

I am having trouble with an Olympic Model 1TD13M, Chassis CD. When the set is on the bench using a 5AXP4 and a substitute yoke, it works fine. But, when it is back in the cabinet, it loses horizontal sync within a period of 20 minutes to 2 hours and cannot be adjusted for proper sync. I have checked all parts in the horizontal section with an ohmmeter and VTVM.

W. R. KREILING

Ohio Radio & TV  
Ashland, Ohio

One of the parts which checked OK on the bench might be changing value with the normal temperature rise that occurs when the chassis is in the cabinet. Hold a soldering iron near each of the capacitors and resistors in the horizontal oscillator circuit (and possibly also in the AFC and sync stages) and see if artificial heating of individual components will induce loss of sync. When it does, chances are that the component last heated is the culprit.

## Tuner Replacement

I have a Crosley Model 11-446 which has a defective tuner. Can I replace it with a Standard Coil type?

GEORGE K. WETZEL

Baltimore, Md.

Yes, a 21-mc unit of either the neutrode or pentode type should work. Study the schematic which is normally supplied with the replacement tuner. You may have to do a little rewiring to insure that the voltages called for will be supplied to the proper points on the tuner. Physical mounting of the replacement unit may be your main problem.

## Color TV Grey Scale

I would like to obtain a sensitive light meter for use in adjusting the grey scale on a color TV receiver, but have never seen such a unit available. Photographic-type meters are not sensitive enough.

All color TV servicemen have a problem with this adjustment because they and the customers seem to disagree over "what is white." But once a serviceman got a correct reading for white on his meter, he could set up all sets uniformly.

HAROLD SANNER

Lima, Ohio

Using a light meter sounds like an excellent idea, but the only meter we know of which might do the job is the color temperature meter used by commercial photographers. These are very expensive, but a photo supply house might be willing to loan you one for experimentation. If it doesn't work out, you can be consoled by the likelihood that some customers will never admit satisfaction with the grey scale on their sets—no matter how accurately it has been set up.

PF REPORTER • February, 1958

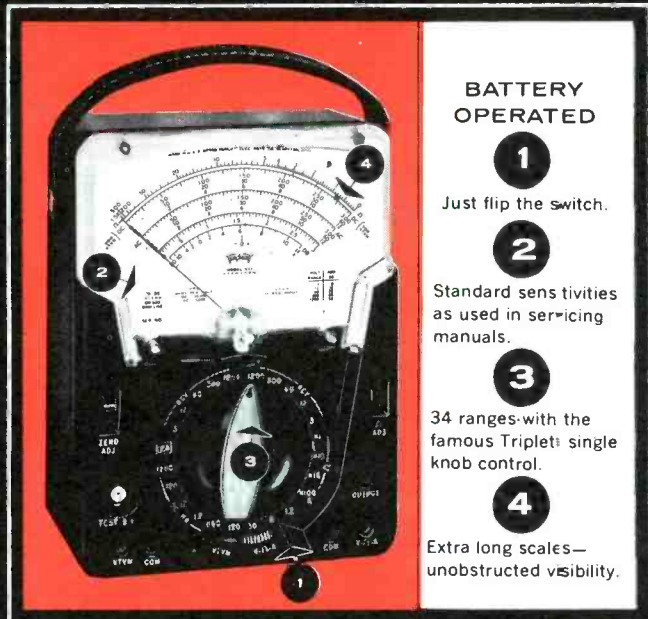

**BATTERY OPERATED**

- 1**  
Just flip the switch.
- 2**  
Standard sensitivities as used in servicing manuals.
- 3**  
34 ranges with the famous Triplet's single knob control.
- 4**  
Extra long scales—unobstructed visibility.

# double use...half the price

Triplet Model 631 the standard Combination VOM and VTVM \$64.50. Here's the *one* instrument which will do practically *all* the measuring in your electronic projects.

A VOM is essential equipment in electronics for measuring current, resistance and voltage. A VTVM is important for voltage measurements where it is desirable that the measuring instrument cause little or no current drain.

By using the Volt-Ohm-Milliammeter for all general testing (90% of your testing) and the Vacuum Tube Voltmeter only when you need it, you have the advantage of a VTVM with extremely long battery life. Batteries are used only about one-tenth as much as in the ordinary battery-operated VTVM.

Features: Ohms, 0-1500- 15,000 (6.8-68 center scale. First division is 0.1 ohm.)

Megohms: 0-1.5 (6,800-680,000 ohms center scale.)

Galvanometer center mark "-0+" for discriminator alignment.

RF Probe permits measurements up to 250 MC. \$7.00 net extra.

Featured by leading electronic parts distributors everywhere.



53 years of experience

## THE MIGHTY MEN



630



630-NA



630-A



310



630-T



666-HH



625-NA



666-R



# QUICKER SERVICING

by Calvin C. Young, Jr.

## Analyzing Interacting Circuits

It is often very easy to take a set of symptoms, analyze them and then decide that the trouble is due to malfunction of a particular section of a receiver. It is not always as easy to locate the cause of this malfunction when it is the result of interaction between the various circuits in a receiver.

This factor is emphasized by the many letters on service problems received from readers. By analyzing the symptoms given in these letters, we are able to quickly decide that the trouble is AGC malfunction, sync failure, lack of B+, etc., based on the particular set of symptoms. It isn't that easy to tell the inquirer that R101 is the defective part, because there could be a dozen or more other parts that could cause the same trouble.

The keyed AGC system is prime example of a circuit in which interaction complicates troubleshooting. In this system,

AGC depends on the presence of a video signal on the AGC grid and a horizontal pulse signal on the keyer plate. Since the grid signal depends on the AGC voltage applied to the tuner and video IF stages, you must determine whether it is a lack of video signal to the AGC keyer or a lack of AGC voltage to the tuner and IF circuits that is causing the trouble. This problem is resolved by clamping the AGC line with a suitable bias voltage. If normal operation is thus restored, it means lack of, or incorrect, AGC voltage is causing the trouble; if not, a loss of video signal to the keyer stage is indicated.

This interdependency between circuits of a TV receiver complicates servicing only if the technician fails to recognize it and make the proper isolating tests.

## Voltage Divider Stages

As you know, prices generally have been steadily increasing, and

yet the cost of a TV receiver is much lower today than it was several years ago. Part of this lower cost is due to volume production, but the major reason is simplified circuitry which uses only about a third of the tubes and components used in earlier receivers.

Remember the heavy power transformers, dual 5U4G rectifiers and B- and B+ circuits with large high-wattage resistors used back in the days of the 630 chassis? This expensive and bulky power supply has been replaced in the modern receiver by a pair of inch-long cartridges about the diameter of a pencil (silicon rectifiers used as voltage doublers), along with simple circuits designed to produce automatic voltage division. We say automatic division; actually many circuits are used in a series-parallel combination such as the one illustrated in Fig. 1. In this type of setup, the high B+ voltage is applied to the plate of the audio output tube and the cathode serves as a power source for several other circuits. The current for all the circuits thus connected flows through the output tube. For a 12L6, this current will be about 50 ma, and since the total B+ current in the average receiver using this type of voltage divider network is usually less than 200 ma, approximately one fourth of the total B+ current

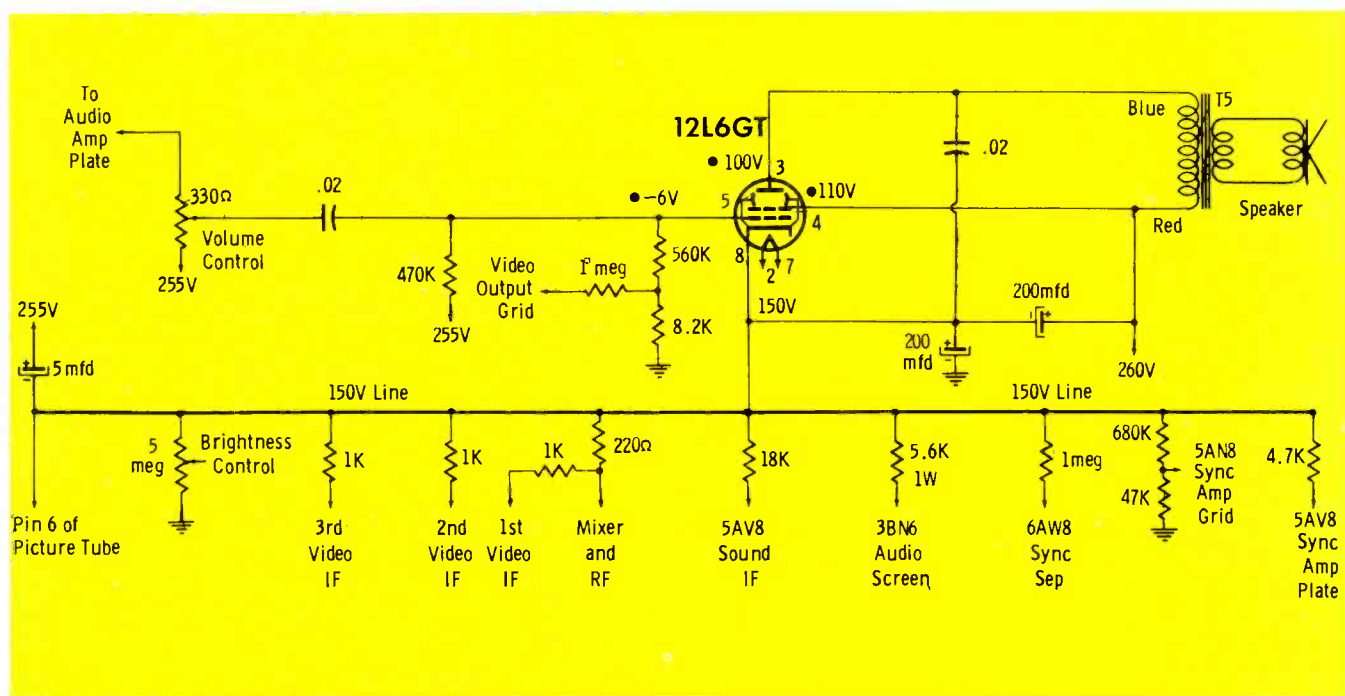
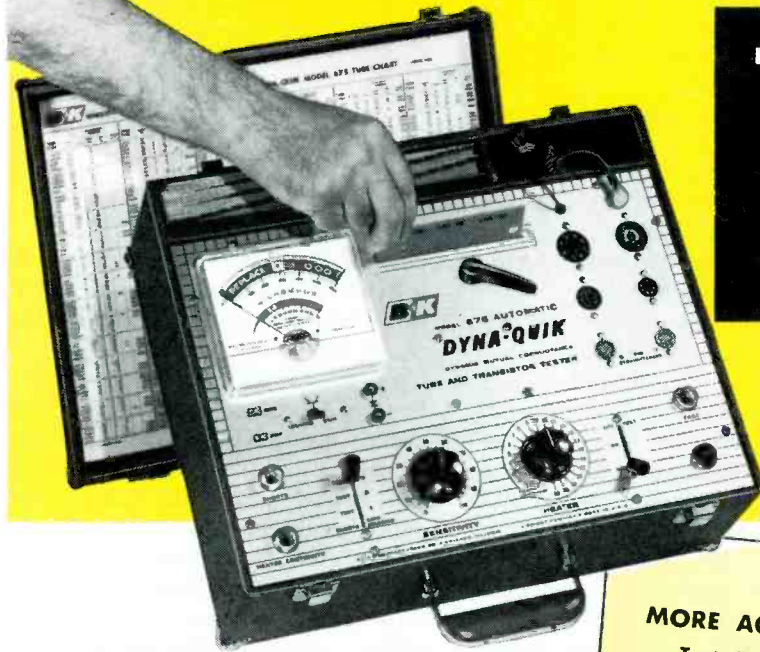

Fig. 1. Audio output stage used as a voltage divider.

You can do more than ever before with this new portable **B&K**

# AUTOMATIC MONEY-MAKER



**TESTS TUBES  
AND TRANSISTORS  
Automatically**  
WITH LABORATORY ACCURACY

- Saves Servicing Time
- Sells More Tubes
- Satisfies More Customers



**B&K** MODEL 675  
AUTOMATIC  
**DYNA-QUIK**  
DYNAMIC MUTUAL CONDUCTANCE  
TUBE & TRANSISTOR TESTER

### MORE ACCURATE TEST

Tests Each Section of Multiple Tubes Separately for Gm, Shorts, Grid Emission and Life

Tests each tube for Gas Content and Grid Emission simultaneously with Short check. Instantaneous Heater Continuity test.

### SIMPLIFIED AUTOMATIC DYNA-CARD SYSTEM

With only 60 heavy-duty, phenolic Dyna-Cards you can test over 500 tube types. Dyna-Card automatically sets socket connections for quick, accurate test. Each Dyna-Card is identified and indexed, ready to use. Always kept up-to-date simply by adding new Dyna-Cards. Minimizes obsolescence.

### CHECKS OVER 99%

of the tubes most widely used in television receivers plus popular home and portable radio tubes.

### ONE EXTRA TUBE SALE

on each of 5 calls a day pays for the Dyna-Quik in a few weeks.

### TESTS TRANSISTORS, TOO

Transistor Section checks junction, point contact and barrier transistors, germanium and silicon diodes, selenium and silicon rectifiers.

Again, B&K helps servicemen give faster, better service at less cost and make more money. The new automatic Model 675 makes tube checking quick and easy in the home or shop. (Tests transistors, too.) Measures true dynamic mutual conductance. Makes complete tube test in seconds, under actual operating conditions of the set. Checks average set in a few minutes. Simple to operate. No multiple switching. No roll chart. Shows customer the true condition and life expectancy of tubes in the set, sells more tubes on-the-spot, saves call-backs. Quickly pays for itself.

Shows tube condition on "Good-Bac" scale and in micromhos. Large 4½" meter has two highly accurate ranges calibrated 0-6000 and 0-18,000 micromhos. 7-pin and 9-pin straighteners are mounted on panel. Automatic line compensation. Special bridge monitors line voltage continuously. Light weight, easily portable in handsome leatherette-covered carrying case. Operates on 105-125 volts 60 cycle a.c. Size: 15¼" x 12¼" x 6". Net wt: 10½ lb. Net, **\$169<sup>95</sup>**

Also makers of famous CRT, DYNA-SCAN, CALIBRATOR



See your B&K Distributor, or write for Bulletin 675-R

**B & K MANUFACTURING CO.**  
3726 N. Southport Ave. • Chicago 13, Illinois

Canada: Atlas Radio Corp., 50 Wingold, Toronto 10, Ont. Export: Empire Exporters, 439 Broadway, New York 13, N.Y.

# Here's why

THE WINEGARD COLOR-  
'CEPTOR IS OUTSELLING  
ANY OTHER ALL-CHANNEL  
YAGI TODAY!

## TECHNICIANS LIKE

to sell the antenna that has set the *standard of performance* for the industry. *No other* all-channel antenna performs like the Color'ceptor. Color'ceptor pulls in the *best possible picture* . . . on any channel, anywhere, anytime!

## TECHNICIANS LIKE

the Color'ceptor's *sunfast gold anodized finish* . . . one of several Winegard features that so many antenna manufacturers have imitated. The Color'ceptor *looks better* . . . *lasts longer!*

## TECHNICIANS LIKE

the Color'ceptor's *extra sturdy construction* . . . the reinforced reflectors; the heavy duty, hi-impact insulators; the precision drilled holes; the all-metal phasing lines and the rugged stainless steel hardware that locks every element firmly in place!

## TECHNICIANS LIKE

to *install* the Color'ceptor. It goes up *quickly, easily* . . . perfectly balanced at the mast clamp . . . *eliminating strain* on rotor, guy wires, etc.!

## TECHNICIANS LIKE

the way Winegard *helps them sell!* You get co-op advertising; national advertising; free truck and window decals, window banners, counter cards, check-up sheets.

Be sure you get *your share* of Color'ceptor sales and profits! Sell the antenna that is the *number one* choice of professional TV technicians from coast to coast . . . the *Winegard Color'ceptor*.

For full information, see your distributor or write



**Winegard Co.**

3002 Scotten Blvd.,  
Burlington, Iowa.

will be influenced by the operation of the audio output stage.

This doesn't mean that one fourth of the circuits in the receiver will get their B+ power from this divider, because actually more than half the circuits (tuner, video IF, sound IF, audio amp, picture tube focus, and sync circuits) are supplied.

Some very peculiar troubles can occur because of faulty operation of the divider system. Let's examine the circuit in Fig. 1 as an example. Notice that the sync separator is supplied through a 1-meg resistor from the 150V line. This provides the proper plate voltage for the 6AW8 to accomplish separation. Notice also that the sync amplifier plate is supplied through a 4.7K-ohm resistor and that bias for the grid is determined by the voltage division across resistors of 680K and 47K ohms in series. Should the 150V line rise to say 175V, there is a very good possibility that the sync separator would begin to pass some video. This could cause poor sync or even twitching in the picture. The accompanying change in the volume level would be compensated (without your knowing it) by a simple adjustment of the volume control.

The situation would be further accented since the IF and tuner stages would have higher than normal voltages, resulting in added gain and possibly a greater than normal signal at the input of the video detector. Too much signal at this point will introduce sync clipping and thus unstable synchronization.

This fact was brought home when servicing a Bendix receiver recently. The picture would suddenly go negative but could be restored to normal by switching off-channel and back again. This receiver employed an AGC keyer, so it was suspicioned that this stage was not operating normally. As an isolating step, the AGC line was clamped with a variable bias source (AGC keyer tube removed), yet the trouble persisted. This proved that improper operation of the signal circuits rather than the AGC circuit was causing the trouble.

Having isolated the trouble to the signal circuits, a VTVM was employed to check voltages at key

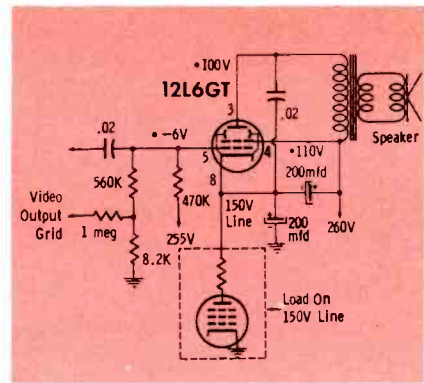

Fig. 2. Simplified divider circuit.

points. At the third measurement, it was determined that the 150V line was operating at 200V (in this case, the audio output tube, a 6W6, was supplied from the 350V source). Replacement of the 6W6 cured the AGC trouble. It also cleared up the slight garbling of the sound that had previously gone unnoticed.

Now that we have gone over some of the troubles caused by improper operation of the audio output voltage divider circuit, let's examine the operation of the stage itself. A simplified version of the circuit in Fig. 1 is presented in Fig. 2, upon which the following explanation is based.

As you can see, the DC current path is through the entire load on the 150V line and then the 12L6GT and output transformer to high B+. Since these circuits are in series, the same current flows through each one and the voltage divides according to their respective resistances. (The load on the 150V line is actually several parallel branches, but these are collectively in series with the output stage.

It is well known that single-ended audio output stages are operated class A to prevent distortion. This means the control grid must be supplied with a potential slightly lower than 150V if normal operation is to be obtained. This is the purpose of the resistive divider network consisting of 560K and 8.2K resistors from the grid to ground and a 470K to B+. The voltage tapped across the 8.2K unit provides a fixed bias for the video amplifier stage.

Looking further into the output circuit, we find two 200-mfd capacitors connected in series from the low side of the audio output

# Use Delco Radio Service Parts!

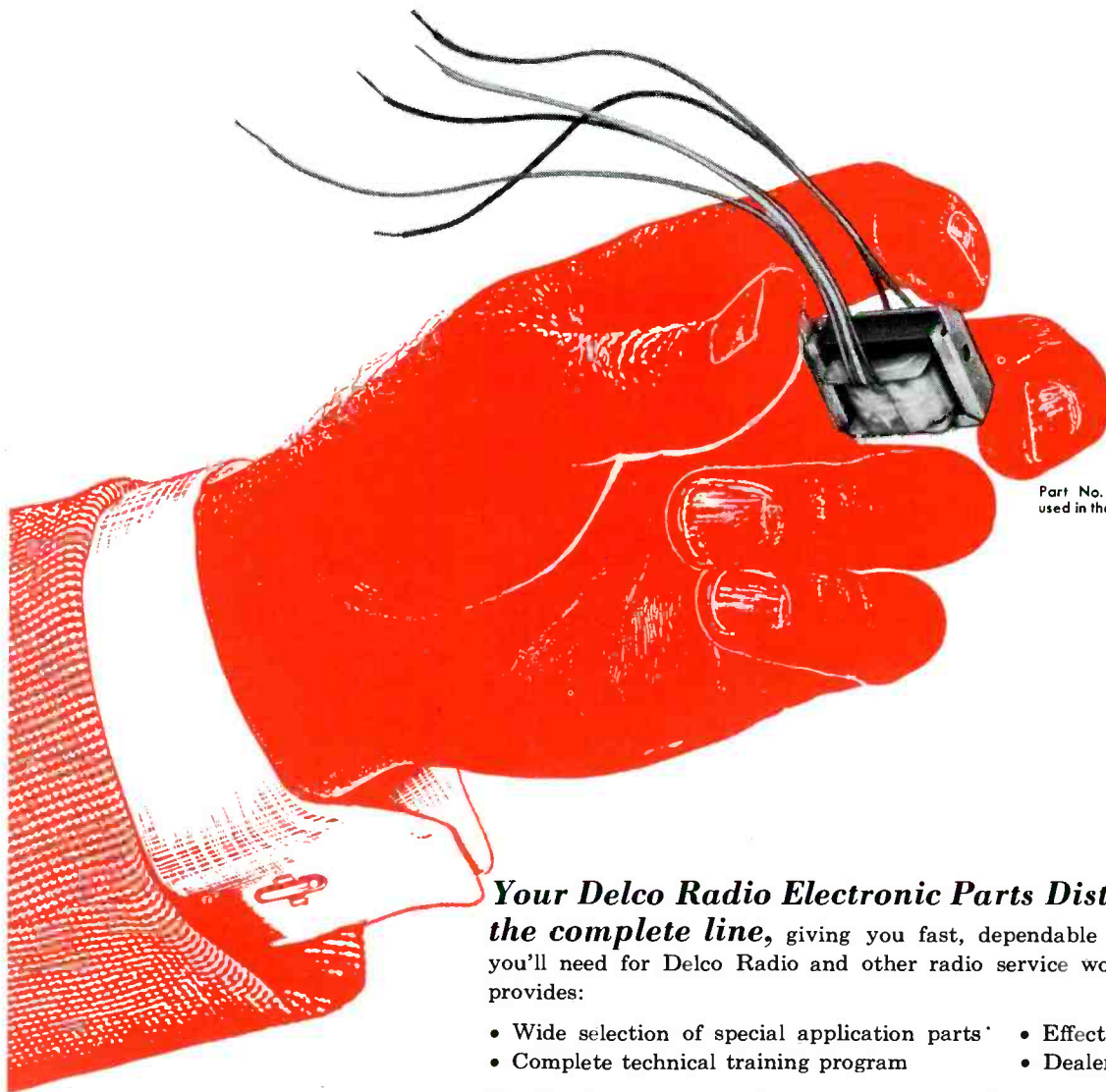

Part No. 7270804—output transformer used in the new Delco Portable Car Radio.

**Your Delco Radio Electronic Parts Distributor carries the complete line,** giving you fast, dependable service on the items you'll need for Delco Radio and other radio service work. Delco Radio also provides:

- Wide selection of special application parts
- Complete technical training program
- Effective warranty program
- Dealer identification signs

Get the facts today on this truly profitable dealer setup, and grow with General Motors!

Available everywhere through Electronic Distributors associated with . . .



## DELCO RADIO

DIVISION OF GENERAL MOTORS, KOKOMO, INDIANA

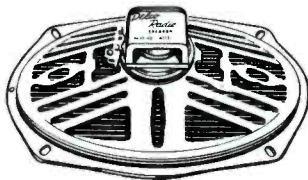

SPEAKERS

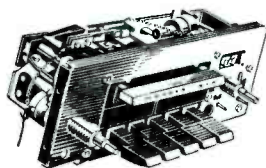

TUNER PARTS



TRANSISTORS



TUBES

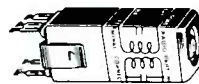

COILS



VIBRATORS



IRON CORES



RESISTORS



CAPACITORS



CONTROLS

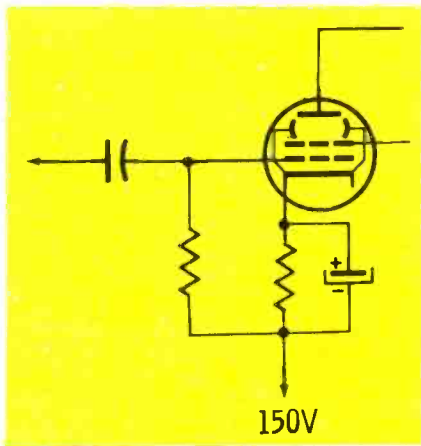

Fig. 3. Alternate bias setup.

transformer to ground with their junction tied to the 150V line. The one that connects from the 150V line to ground is simply a filter to decouple the audio output stage from the circuits connected to the 150V line. The other capacitor filters the 260V applied to the plate of the output stage and bypasses the screen grid to the cathode. The .02 capacitor is for tone compensation and to keep high frequency transients out of the transformer primary winding. Viewed in the foregoing manner, we see that this type of audio out-

put stage is just like any other except that it also serves as a DC voltage divider.

One other thing—the example used here employs fixed bias by virtue of the resistive divider in the grid circuit; other circuits may employ cathode bias and have the low side of the grid load resistor connected to 150V with a resistor between the cathode and the 150V line (Fig. 3). The cathode resistor may or may not be bypassed. In this configuration, bias is furnished by virtue of the voltage drop across the cathode resistor.

YOU ALWAYS  
GET MORE  
THAN YOU  
*Expect*



WHEN YOU BUY  
**TENNA**  
ANTENNAS!

THE TENNA MANUFACTURING CO.  
CLEVELAND 25, OHIO

MADE BY THE WORLD'S LARGEST  
MAKER OF AUTOMOBILE ANTENNAS



★ Model MH-57C-54 pictured at left, is the only competitively priced all chrome antenna on the market.

★ Unique Ball and Rocker mounting Base mounts speedily from the top.

★ One piece, die cast antenna body assures sturdy, dependable mounting.

★ New, large rubber adapter pad covers largest existing holes.

★ New locking feature locks ball securely in position.

*Destined to become the largest selling replacement antenna in 1958. Contact your parts jobber at once.*

MODEL  
MH-57C-54

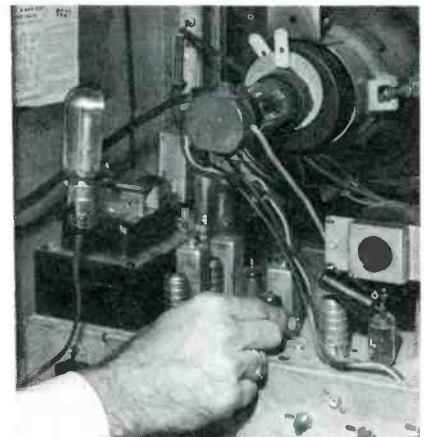

Fig. 4. R-Columbia's Magna-Lite in use.

#### Magnetically Mounted Lamp

The R-Columbia "Magna-Lite" being used in Fig. 4 features three-way swivel action plus a movable shade in addition to its heavily magnetized base. This unit is supplied with a bulb of standard brightness although another classed as super bright is also available.

The magnetic base makes the unit handy for servicing in the home since the light may be attached to any magnetic metal, leaving both hands free for servicing. The small physical size of the lamp makes it possible to carry it in the regular service kit or caddy.

#### CRT Testing in the Home

There are a great many sets in the field that are approaching the end of their normal, average life span, which is reported to be 6 to 8 years by several engineering authorities. In addition, there are a good many sets that customers have simply kept when they bought a new one because the trade-in offer was too low to suit them. The customer may decide,



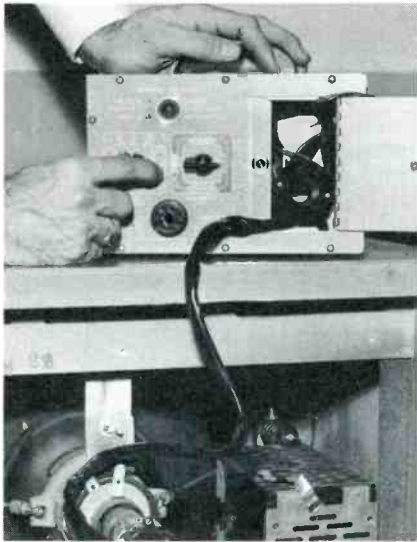

Fig. 5. EICO Model 630 CRT tester.

however, that maybe the set could be repaired for use in the basement recreation room or in Junior's upstairs bedroom.

This second set usually enters the picture when the service technician reaches the home to service the newer receiver, and the customer generally has a pitch that goes something like this. "If this other set can be fixed and not cost too much, we'd like to have it fixed for Junior's birthday." Careful questioning may reveal that \$20 to \$25 would be tolerated, but no more. If you simply pack the set off to the shop and wade into it, you may find out \$20 later that the set is okay with the exception of the picture tube. You call the customer and he says, "No! Bring it back and forget about the whole thing." While you may be able to collect something for your trouble, you usually wind up in the red on a deal like this.

Having a small, portable picture tube tester of the type shown in Fig. 5 available on the first home call would have allowed you to test the picture tube in the customer's presence. With you right there to do a little selling, you're likely to get the go-ahead even to the tune of a new picture tube in a good percentage of the cases. This certainly would offset the loss previously mentioned, and should get back your investment in the checker to boot.

In addition, a picture tube tester may help to close sales on tubes that are bad but still provide a picture—but a poor one, at best. ▲



**"REALIZING THAT WE'RE TAMPERING WITH THE  
VERY FOUNDATIONS OF THE HOME LADY,  
OUR FINAL TEST IS 5 MINUTES OF MUSICAL  
APPRECIATION TO INSURE A FLAWLESS JOB . . ."**

Your customers, will renew their appreciation for music, Gus, when you use Webster replacement cartridges.

And there's a Webster for 'most any job you'll run into. Each one fits perfectly—and restores the original qualities to the player.

There's more money in it for you, too, because there's no call-backs — no unhappy customers.

**BUY WISELY...BUY WEBSTER!**



Model B202—3-speed; push-in mounting; clip-mounted needles.

Free—large print of this Lichte cartoon suitable for framing. Request on your own letterhead.

ELECTRONICS DIVISION

WEBSTER  ELECTRIC  
RACINE · WIS

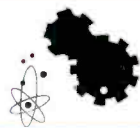

# CHEMICAL SENSERS

## part 6

by Melvin Whitmer

today's high quality standards. This month, we shall discuss the chemical sensors which aid in maintaining this exact control.

Chemicals have the property of reacting with each other; if this were not the case, our life would indeed be far different. The study of these interactions are very important to industry, and thus it is also important for the industrial electronic technician to develop at least a nodding acquaintance with the chemist's language.

Chemicals are commonly divided into acids, bases, and salts. Salts are those chemicals which do not attack other chemicals and are classed as passive compounds; however, when in solution, the molecules diffuse throughout the solvent, and generally serve to reduce the resistance of the solution. A method of controlling the concentration is to control the resistance, or the reciprocal conductivity of the solution.

### Conductivity-Sensing Units

One device used for sensing conductivity is a bridge arrangement with a null balance indicator such as a cathode ray "eye" (Fig. 1). The dial is calibrated in micromhos, and solution temperature is compensated for by the lower knob. The screwdriver adjustment at the very bottom is a calibration control. When used for continuous control, the null balance is replaced by a vacuum tube, and the output signal is used to alter the concentration. The instrument in Fig. 1 is a battery-operated unit with a built-in 1,000-cycle oscillator, while the unit in Fig. 2 is the AC counterpart which operates from a standard 117 VAC source. The probe shown with the control box in Fig. 2 is an immersion type with a cross-sectional area of one centimeter.

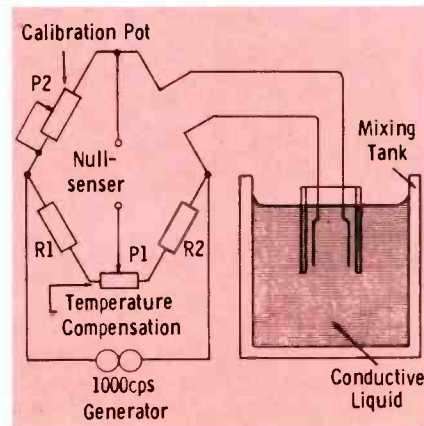

Fig. 3. Solu-Bridge circuit.

The schematic of the bridge used in these instruments is shown in Fig. 3. Note that the right leg consists of the probe, whereas the left leg contains the calibration potentiometer P2. Temperature compensation is achieved through the use of potentiometer P1.

The conductivity measuring unit will work with concentrations of both acids and bases; however, the probes must be of a non-reactive composition. One disadvantage of a conductivity test is that chemically pure ingredients are mandatory because an unwanted salt will affect the conductivity as much as the desired salt.

### Oxidation-Reduction Potential

Another method of measuring salts uses the difference of potential formed as a result of the electron and ion exchange which takes place whenever different substances come in contact with each other. If two probes are used, one which becomes positive and the other negative with respect to the liquid, the potential difference can be measured and used as an indication of the relative concentration of salts. Instruments in this general classification are called oxidation-reduction potential meters.

Either metal or solution electrodes may be used. Metal electrodes are used for most industrial

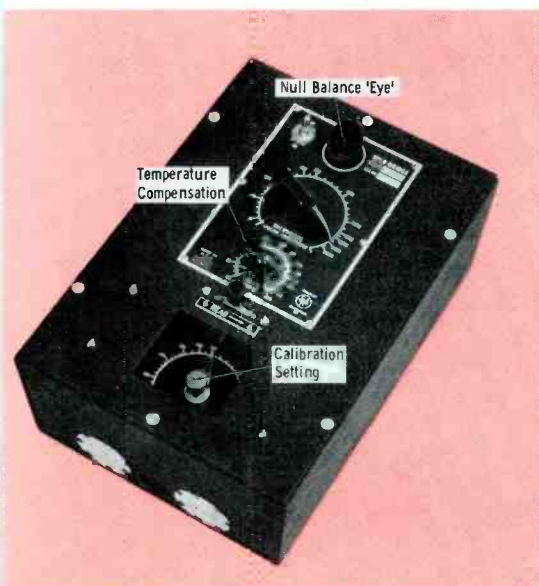

Fig. 1. Solu-Bridge conductivity meter.



Fig. 2. AC-power Solu-Bridge.

Chemicals are used by industry to clean, alter, or separate the raw materials of almost every product on the market. Electronic component parts manufacturers, for example, use chemicals in the manufacture of plastics, insulators, and electrolytes. An error here can mean poor quality parts and, later on, headaches for the technician. Thus, it is only through careful control that chemicals can meet

# LIKE MAGIC!

## CLAROSTAT CONTROLS

*fit right...  
work right...  
every time!*

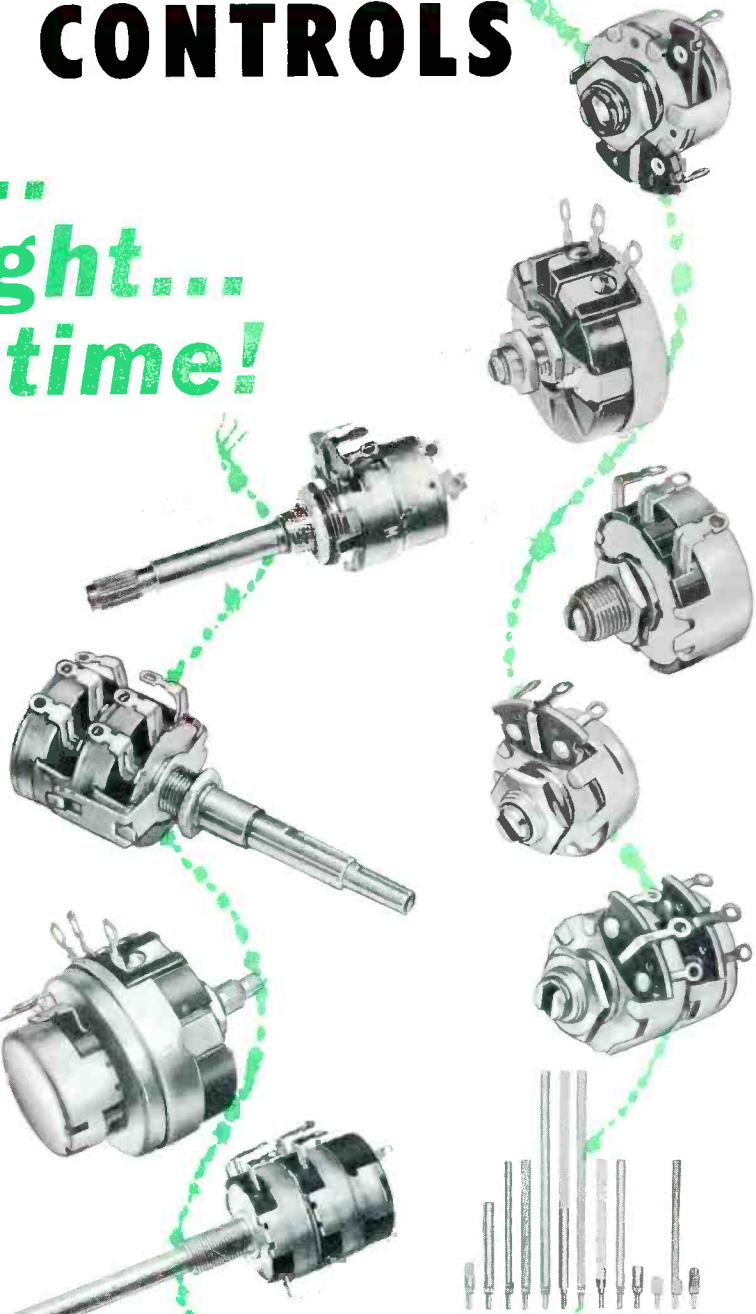

### RTV\* CONTROLS

Matched Clarostat replacements for usual or unusual electrical and mechanical requirements and combinations.

### STANDARD CONTROLS

Clarostat standard numbers offering the widest choice of mechanical and electrical variations in wire-wound and carbon types.



\*Reg. U.S. Pat. Off.

*Controls and Resistors*  
**CLAROSTAT MFG. CO., INC., DOVER, NEW HAMPSHIRE**  
In Canada: CANADIAN MARCONI CO., LTD., TORONTO 17, ONT.

... another  
**P. R. MALLORY & CO. INC.**  
**MALLORY**  
 service-engineered  
 product

watch out for  
 shrinking  
 capacitance

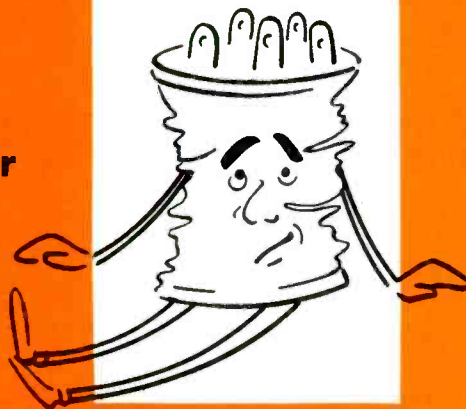

—insist on

# Etched Cathode

Ever notice how some capacitors fail before their time? In just a few weeks, especially in a high ripple circuit, they begin to develop hum.

This is due to loss of capacitance, and it's a common ailment of capacitors with plain foil cathodes.

You'll never have this trouble with Mallory FP's and popular Mallory tubular electrolytics . . . because they have *etched cathode* construction. It's a standard feature of Mallory electrolytics that insures against "missing microfarads."

See your local Mallory distributor for full facts on why etched cathode is important to you—and to your customers!



- Capacitors
- Vibrators
- Resistors
- Power Supplies
- Mercury and Zinc-Carbon Batteries
- Controls
- Switches
- Filters
- Rectifiers

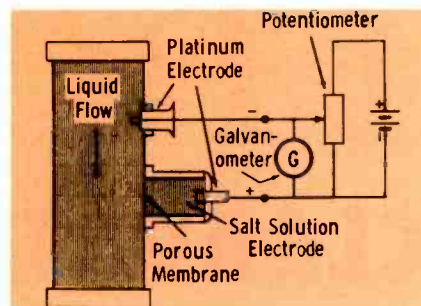

Fig. 4. Oxidation-reduction potential sensor using calibrated linear potentiometer.

indicators, except in solutions which are predominantly acid or base. Several of the noble metals, such as platinum, silver and gold, are stable electrodes since they introduce very few side reactions. Fig. 4 is an example of solution electrodes which form a standard potential with the metal probe; only the solution comes in contact with the liquid to be measured. The junction of the salt solution and the liquid to be controlled forms a potential difference which is proportional to the ion concentration of the controlled liquid. This electrode has the desirable feature of isolation, but requires the use of an exchange membrane which will pass ions and, at the same time, maintain the chemical difference between electrode and controlled liquid. Also, measurement of the potential difference must be accomplished without current flow through the liquid, an action which would alter the potential difference because of electrolysis action at the electrodes.

Potentiometers of the type described in Part 2 (October, 1957) of this series are voltage determining devices which do not require any appreciable current. In Figure 4, the electrodes are connected across the galvanometer so that the voltage tapped from the battery by the potentiometer opposes that available from the two electrodes. When the galvanometer indicates that a no current condition exists, the electrode voltage and the potentiometer voltage are exactly in balance. The latter can be read directly from a dial calibrated in millivolts. Automation can be further introduced by replacing the galvanometer with a very sensitive vacuum tube circuit which develops an error signal for controlling the concentration of the salt in the liquid.

## pH Sensors

A refinement of the preceding operation results in the ability to determine acidity or baseness even in the presence of salt ions. By using electrodes which are sensitive only to hydrogen or hydroxyl ions, the ability to oxidize or reduce is limited to acids or bases. Hydrogen ion concentrations range from  $10^{-1}$  or less for an extreme acid to an almost complete lack of the hydrogen ion where the concentration is  $10^{-14}$  or less.

In a predominantly acid solution, there are a great many free hydrogen ions. The symbol for hydrochloric acid is HCl. When this acid is placed in solution, the molecule HCl breaks up into two ions,  $H^+$  and  $Cl^-$ ; thus the more acid a solution contains, the more free hydrogen ions there are.

The hydroxyl ion is a negative ion formed by an association between one atom of oxygen and one atom of hydrogen. Since the oxygen atom has a surplus of two electrons, the result of the OH combination is a charge of  $-1$ ; thus, in a solution which is primarily base, (for example, NaOH sodium hydroxide) the ion  $OH^-$  is formed, not the ion  $H^+$ . In fact, if there is a free H ion in the solution, it is apt to be captured by the  $OH^-$  to form  $H_2O$ , water.

Sorensen, in 1909, proposed a convenient scale which has been generally accepted for hydrogen ions in solution. For a unit, he selected the letter combinations pH. His formula was:

$$pH = -\log_{10} 10^{-x}$$

where  $10^{-x}$  denotes the hydrogen ion concentration in the solution. Thus, a solution with an  $H^+$  concentration of  $10^{-1}$ , has a pH of 1, and is acid. Water has an equal concentration of  $H^+ = 10^{-7}$  and  $OH^- = 10^{-7}$ ; therefore, the pH of water is 7. Bases have smaller concentrations of  $H^+$  and larger concentrations of  $OH^-$  ions. pH numbers for bases range from a pH of 8 to a practical maximum of 14.

For pH measurement, electrodes of both reference and glass are used. One type of reference electrode is shown in Fig. 5. A porous container is filled with a strong salt solution of KCl. Mercury is placed in the bottom to form a

February, 1958 · PF REPORTER

# Wet Weather Never Bothers A MALLORY "GEM"



Run-of-the-mill radio and television equipment may never be called upon for such extreme service as under-water operation . . . but if it were, you could be sure that Mallory Gem capacitors would continue to deliver excellent performance.

Mallory "Gems" are tightly sealed in a mica filled bakelite case with epoxy resin that adheres both to case and wires . . . they withstand moisture and exposure without change of capacity or internal resistance. And, they're conservatively rated to assure complete reliability under the most severe conditions.

They're your best bet for outstanding service in any application—for by-pass, buffer, filter nets, or coupling circuits. Get Mallory "Gems" in all popular capacities and voltage ratings—from your Mallory Distributor.

P. R. MALLORY & CO. Inc.  
**MALLORY**

P. R. MALLORY & CO. Inc., INDIANAPOLIS 6, INDIANA

- Capacitors
- Vibrators
- Resistors
- Power Supplies
- Controls
- Switches
- Rectifiers
- Filters
- Mercury and Zinc-Carbon Batteries



**NEW!**  
MASTER CONICAL  
#4051, \$9.75 LIST



whatever your  
antenna need

**HAS IT!**

and the completely new

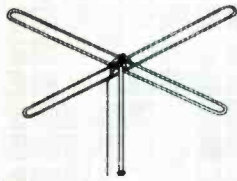

**NEW!**  
FM TURNSTILE KIT  
#4656, \$14.95 LIST



**TV ANTENNA  
CATALOG lists it!**

For example, **NEW IMPROVED  
SUPER WIZARD FRINGE ANTENNA**

The finest fringe antenna you can buy—over 14 db gain, extremely sharp directivity, smooth response, and completely pre-assembled for instantaneous installation. Give your customers the very best—give them the Super Wizard. #4240, \$37.90 List

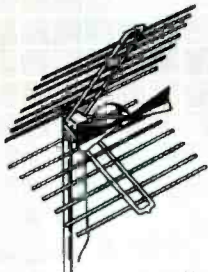

**NEW!**  
SPEED RIG  
CORNER REFLECTOR  
#4471, \$8.95 LIST

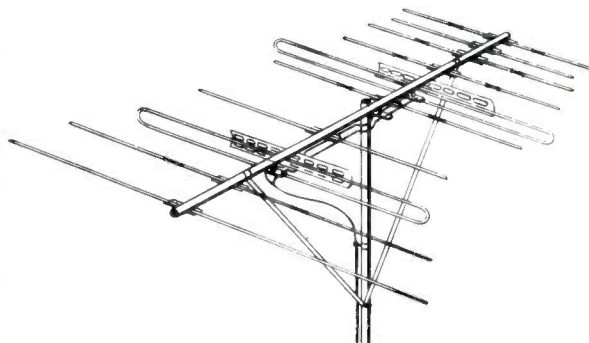

**NEW!**  
DELUXE UHF BOW-TIE  
#4467, \$3.95 LIST

All these, plus 11 new conicals and 8 new UHF, have been added to the WALSCO line, making it among the most complete and comprehensive in the industry. Carefully engineered and as up-to-date as tomorrow, WALSCO TV antennas are your finest choice always.

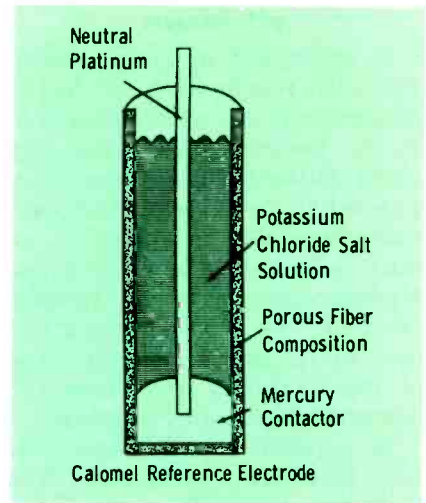

Fig. 5. Calomel reference electrode.

large contact surface with the solution and good electrical connection with the inert electrode. The unit is called a calomel reference electrode. Ion exchange takes place through the porous container wall between the salt solution and the measured liquid. Glass electrodes allow passage of hydrogen ions only, and it is this characteristic which allows accurate measurement of hydrogen ion concentration. Potential difference is measured between the glass and reference electrodes with a temperature compensating resistance placed in series.

### Summary

Adequate control of chemical reactions must include the physical as well as the chemical characteristics. Pressure and rate of flow aid in measuring quantity. Viscosity and density are usually end product qualities; therefore, measurement of these characteristics have to do with the control exercised over production techniques.

Resistance, oxidation-reduction potential, and pH measurements are used in the control of the chemical reactions which take place in the manufacture of products or processing of raw materials to improve their physical qualities. Input transducers for temperature, liquid and chemical characteristics have been described thus far. Part 7 will describe vibration sensors used for flow and hidden stress detection, grinding and soldering by agitation methods and other interesting uses for sonic and ultrasonic devices. ▲

**Free!**  
A copy of the brand-new WALSCO TV ANTENNA CATALOG... at your distributor or write directly to us for it.

**WALSCO ELECTRONICS MFG. CO.**  
A Division of Textron Inc.

102 WEST GREEN STREET, ROCKFORD, ILLINOIS, U.S.A.  
WEST COAST PLANT: LOS ANGELES 18, CALIFORNIA  
In Canada: Atlas Radio Corporation, Toronto 18, Ontario

Please rush me a copy of the brand-new, free WALSCO TV ANTENNA CATALOG.

NAME \_\_\_\_\_  
ADDRESS \_\_\_\_\_  
CITY \_\_\_\_\_ ZONE \_\_\_\_\_ STATE \_\_\_\_\_

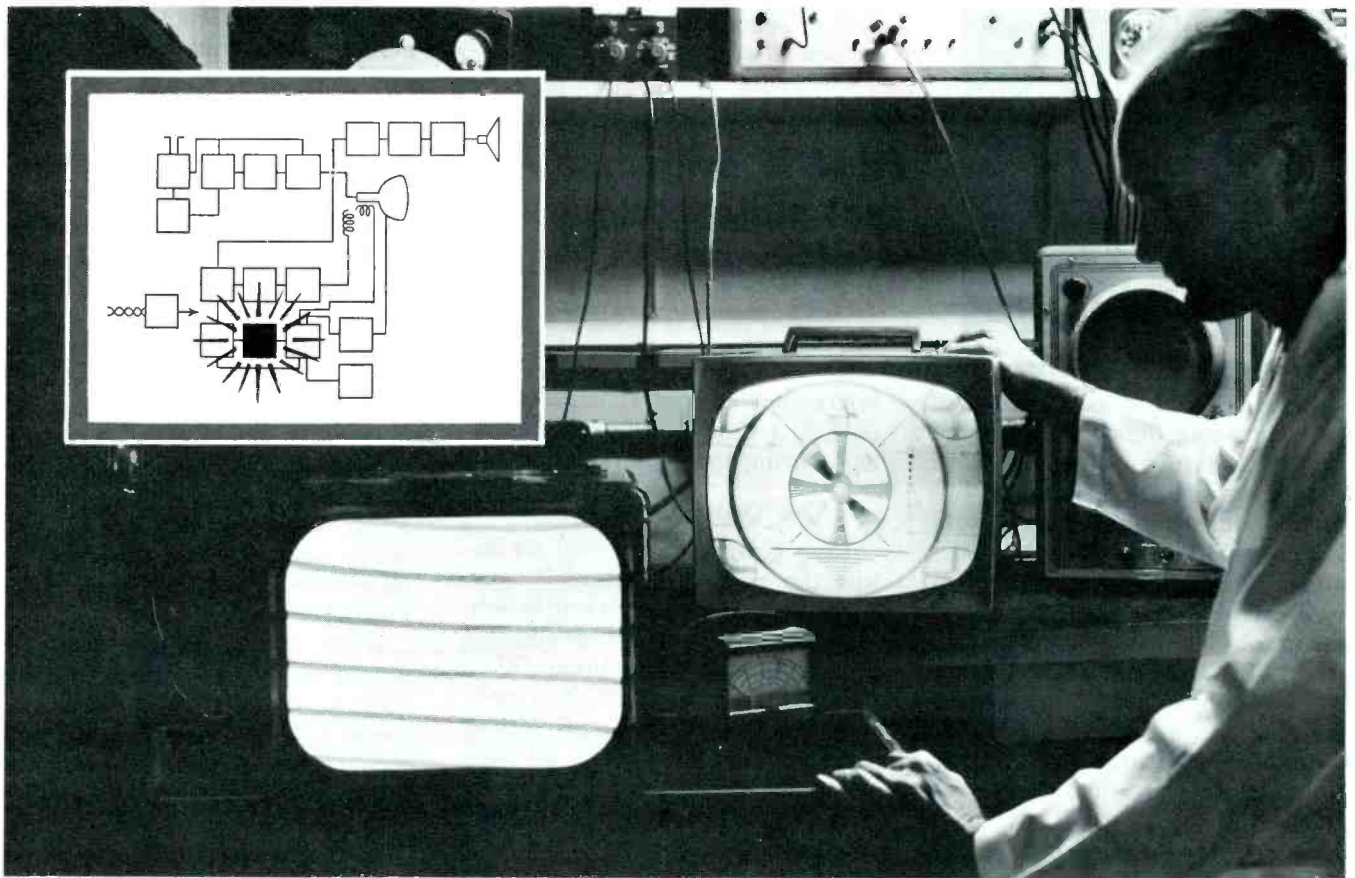

Here General Electric Application Engineer C. L. Taylor shows what can happen when an old-style horizontal-oscillator tube is used in two different TV sets. Image at left is completely

out of sync. To avoid this hazard, the cut-off and other electrical characteristics of General Electric tubes are held within limits that bring satisfactory operation in all television circuits.

## Built-in high quality of G-E horizontal-oscillator tubes means fewer TV-servicing call-backs!

Call-back demands from television owners are cut when you install General Electric horizontal-oscillator tubes.

For example: tube microphonics in multivibrator circuits can cause eccentric sync, especially when a set such as a portable is moved or shaken. With G.E.'s 7AU7 and 12AU7, extra-heavy micas, the tight fit of grid side rods, plate, and cathode, and sturdy over-all construction result in minimum microphonics and a steady television picture.

Also, uniform tube-to-tube cut-off characteristics—achieved by care in grid manufacture and rigid testing—enable you to install General Electric types in any receiver knowing that minimum adjustment will be needed for superior picture performance.

Blocking-oscillator circuits require that a tube

throughout its life be able to produce peak plate currents 10 to 15 times higher than average. In the 6CG7 and 6SN7-GTB, General Electric scores with a specially processed high-emission, long-life cathode. Peak current capabilities remain high; sync drift is avoided.

For every set, for every socket, G-E receiving tubes mean greater assurance of owner satisfaction . . . and your G-E tube distributor makes prompt delivery. Phone him today! *Distributor Sales, Electronic Components Division, General Electric Co., Owensboro, Ky.*

*Progress Is Our Most Important Product*

**GENERAL  ELECTRIC**

161-1A9

# system for starting on

# DOGS

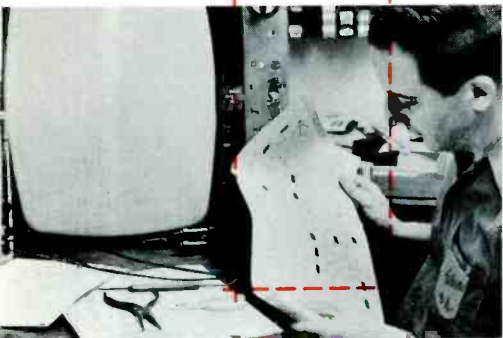

by Art Margolis

It's early afternoon. Most of your pressing details are cleared up. The time has come. You should work on that dog now, but your mind has other plans. There is a steaming cup of java two doors away. That tube order for next week should be made up. Next month's advertising layout beckons from a closed desk drawer. A slight headache begins over your left eye. After about ten minutes of such musings you say to yourself, "I just can't get started!"

That is the hardest part of repairing a dog. Why do you hesitate? Subconsciously you feel a fight coming on. Maybe this chassis is going to be the one you can't fix. With this thought in mind, your subconscious looks for easier jobs to do. It tries to substitute activity for purpose. The only thing that jolts you back to reality is the set owner making your telephone vibrate.

These feelings are natural enough. The main thing is to recognize them. Once that is done, you can work out a system to circumvent your subconscious. I thwart my subconscious revulsion for dogs with a simple procedure. The system has the effect of reducing inertia, refreshing my memory, is orderly and scientific, and brings the price of dog repair bills down.

It is, by the numbers, a warmup. One, I clean the chassis, lubricate the controls and tuner and clean the CRT and cabinet. Two, I analyze the symptoms, even to the extent of making notes. Three, I pull a schematic out of the files and set up *all* of the necessary test equipment and tools in orderly fashion around the chassis. Four, I make myself comfortable. These simple procedures may sound silly,

## How to overcome that subconscious aversion to "TOUGHIES"

but you would be amazed at the dawdling time saved, both before and during the repair.

### The Question of Inertia

Like electrons, we tend to follow the path of least resistance. Some chassis appear on our bench, look wide open, easy to probe and present no starting problem. Other chassis appear still in their cabinets, packed in like the proverbial sardine, bolts and screws all over the place. These require clumsy maneuvering before a voltage reading can be made. We all tend to shy a bit when we feel it's going to be a long, knock down, drag out repair. That's when a steady starting ritual is useful. It starts you moving whether the chassis looks easy or sickening.

Like a 17" RCA that appeared recently on my bench. It was one of those squash-down specials with printed circuit wiring and the cabinet only as large as the CRT. One of the outside servicemen had replaced the contrast control three times over a period of as many months. Something other than bad controls was causing the trouble. My job? Find it!

I hated to start, but went into my numbered ritual. Before I knew it, I was half way through. I had tricked myself into starting. The symptoms were these: There was good audio, but abnormal video. At a minimum setting of the contrast control, the video had a natural weak appearance. As the control was advanced, however, the picture became smeared and washed out.

I checked the control and found some open spots, indicating that another replacement was needed. I tacked one in temporarily, after which operation seemed perfectly normal. I studied the schematic,

trying to figure out what could cause the control to keep opening up. Since the control was the cathode bias resistor, the most likely possibility was too much current through the 6AW8 video amplifier.

Using the VTVM at my elbow, I checked the plate voltage—it was correct. Then I checked the screen voltage. Instead of the 78 volts indicated on the schematic, I read 200, which would account for the excessive conduction that was slowly burning out the low-wattage contrast pot. There was a 56K between +256 and the screen. If it were partially shorted . . . I measured it—56K. Then I noticed a .47 between the screen and +150 and checked it with the ohmmeter. It read ten ohms! (See Fig. 1.)

After the capacitor was replaced, the screen voltage dropped down to 78 volts. The tube was no longer overconducting, and I permanently installed the new contrast control. The video came in crisp and clear.

As I put away my equipment and the service manual I wondered how much time I would have dawdled away if I hadn't used a starting routine for this seemingly tough job.

### Getting My Memory Refreshed

When I strongly suggested (as the boss often does) that my servicemen also perform these starting rituals, I received the objections, "Why take out all that stuff—you might not need it," "I can fix a lot of sets without a schematic," etc.

Maybe it doesn't work for everybody, but I know when I go

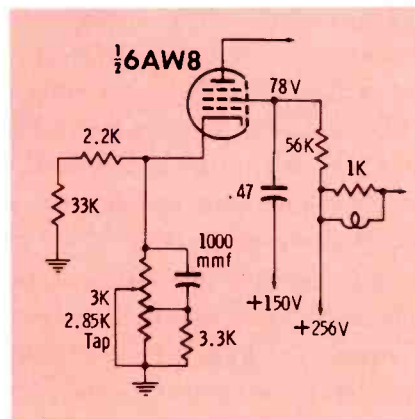
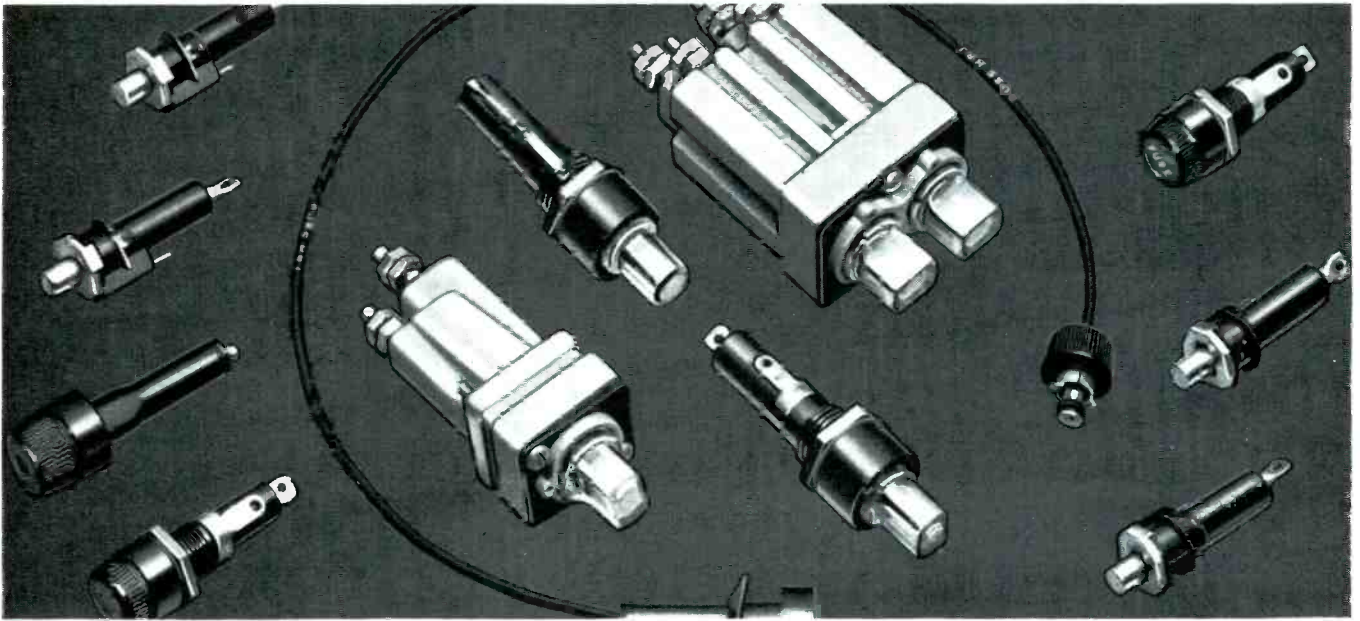

Fig. 1. The shorted .47 increased screen voltage and tube current, resulting in repeated contrast control failures.





**Dependable BUSS FUSES can help protect your profits.**

**Here's how** — BUSS fuses help sales and service organizations avoid adjustments and call-backs because . . . BUSS fuses are designed to operate properly under all service conditions.

Selling or installing BUSS fuses further helps protect your profits by safeguarding you against loss of future business that could result if you handled faulty fuses that failed

to protect or blew needlessly.

The unfailing dependability of BUSS fuses is assured by the careful testing of every BUSS fuse in a sensitive electronic device. Any fuse not correctly calibrated, properly constructed and right in all physical dimensions is automatically rejected.

It is just good business to standardize on BUSS fuses. You are

helping to protect both your profits and your reputation for quality and service.

*For more information* on the complete line of BUSS and FUSETRON Small Dimension Fuses and Fuseholders . . . Write for bulletin SFB. Bussmann Mfg. Division McGraw-Edison Co. University at Jefferson, St. Louis 7, Mo.

***BUSS fuses are made to protect — not to blow, needlessly***



MAKERS OF A COMPLETE LINE OF FUSES FOR HOME, FARM, COMMERCIAL, ELECTRONIC, AUTOMOTIVE AND INDUSTRIAL USE.

**WHEN  
PERFORMANCE  
IS  
AFFECTED BY  
LOW VOLTAGE  
CONDITIONS**

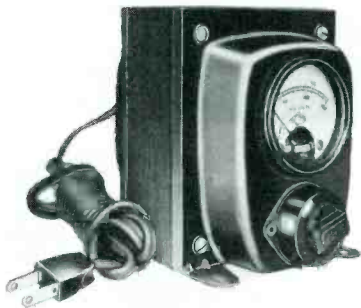

**SELL THIS  
ACME ELECTRIC  
VOLTAGE  
ADJUSTOR**

TV sets are designed to operate best when voltage holds closely to 115-117 volts. Overloaded supply lines (the power industries greatest problem) may result in a voltage drop of 10 to 15% at certain times of day. Usually the TV set will function in a fashion under such low voltage conditions but with a great strain on its components. For example; narrowing of picture, output stage tube life shortened, frequent burn-out of filaments, fuzzy focus have been traced to lack of proper voltage.

These conditions can be corrected with an Acme Electric T-8394M Voltage Adjustor. Simply plug-in to convenient outlet. Plug-in television set cord into female receptacle built into adjustor. Voltmeter indicates output voltage. If voltage is incorrect turn regulating control until proper voltage is reached for best performance. Voltage range 95 to 125 volts. Tell your supply dealer you want the Acme Electric T-8394M. No other so compact, practical, inexpensive.

**ACME ELECTRIC CORPORATION**  
94 WATER STREET CUBA, NEW YORK



through a routine for a particular set with a particular trouble, it gives me just the right stimulus to review that set's idiosyncrasies and bring past experience sharply into view. Even if I don't use all the equipment or service data, their very presence revives past battles with that TV. Sometimes just that familiar moving around brings the repair to completion.

Like a 21" Westinghouse that had all the earmarks of a tough dog. As I cleaned it, all of the similar chassis jobs I've done passed vaguely through my mind. As I analyzed the symptoms, I began to get a *this has happened to me before* feeling. The symptoms were weird. The audio and video were fine; however, starting from the right, the shading of the picture gradually changed, becoming completely black at the left. It looked like 60-cycle hum in the video turned 90°.

As I set up the scope and VTVM, I thought that the only way this condition could happen was if a 15,750-cycle sawtooth was modulating the video output. The saw could cut off the CRT at the beginning of each horizontal line and allow conduction to gradually increase during horizontal trace.

I remembered a parallel case from a long time ago. At that time I had found that a saw wave was arriving at the video amplifier plate. As I pulled out the schematic, I could see my fingerprints on it. Yes, that previous case had also been a Westinghouse and a similar model. It all came back. I didn't have to open the sheet, but I did. There, sure enough and over four years old, was my penciled circle around the 2nd filter in the power supply. (See Figure 2.)

I checked that filter in this chassis and found it to be open. The 120-cycle hum from the power supply was filtered because of the input capacitor and choke, but an open output filter allowed some energy from the horizontal sweep to couple into the video. A new 80-mfd cleared up the condition. In this case, the ritual alone had been enough to locate the bad part.

#### It's Scientific

Another complaint I hear about performing this sort of ritual be-

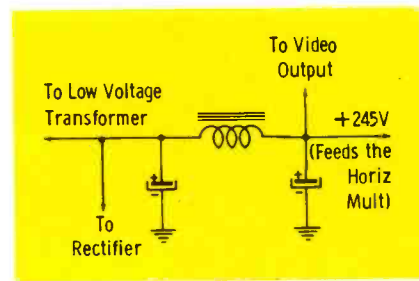

**Fig. 2. The 2nd filter opened, permitting sawtooth energy to reach video section.**

fore each bench job is, "It's too much like school." Personally, I don't consider this a drawback. The putting together of theory and experience to locate a bad-acting component is a science, and school-type scientific procedures should be used in the process.

Sure, there are lots of jobs where you might get away with a hit-and-miss procedure. But sooner than you expect, you'll find yourself hung up, in confusion and doing nothing but starting into the chassis with a bewildered look.

I came in off the street one day and found a new bench man who had made the "too much like school" objection staring almost hypnotized into the underside of a 17" Fada, a VTVM probe lying limply in his hand. I unloaded the truck and refilled my tube caddy. I heard him mutter, "It's a dog."

Naturally, the easiest thing for him to do was stare into the Fada, but since he was getting paid by the hour, I was anxious to see action. I joined him and together we started at the beginning of my ritual—cleaning the chassis. Then we analyzed the symptoms and wrote them down. The picture came on slowly, got darker and darker, weaved, then blacked out. This was true on all but the weak stations. They came on normally, indicating that AGC was somehow snafued.

The test pieces called for were the VTVM, scope and bias box. He set them up and got out the schematic sheet. Now that he was unhypnotized, I left him alone and he began moving. He clamped the AGC supply with voltage from the bias box. The same condition existed, exonerating the AGC circuit and indicating that the trouble should be in the tuner or IF strip. It looked like one of the IF's was oscillating. This was going to be tedious.

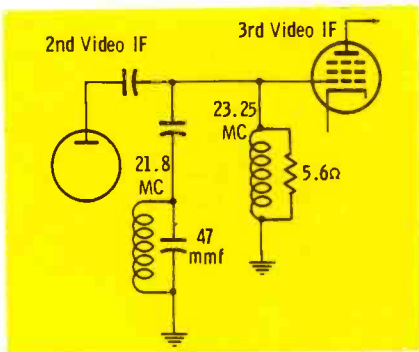

Fig. 3. The 23.25-mc coil developed shorted turns, causing a trouble that could be likened to faulty AGC action.

About fifteen minutes were spent tacking in, one by one, all the bypass and blocking capacitors, coils and transformers. As he tacked in the 23.25-mc tank coil in the grid of the 3rd IF, the condition ceased. (See Figure 3.) I wondered how much time the staring would have consumed if he hadn't started the school-type procedure.

### Brings Down Dog Repair Bills

It is axiomatic that when a soldier goes to battle, he should have as much fire power as possible backing him up. When a TV technician goes into battle with a dog, he should try to have everything going for him, too. Any deviation means taking a chance that can consume time and unnecessarily increase a repair bill.

One of our men was working on a 21" RCA. When he hit the symptom analyzing stage, he found that at first the picture came on perfectly, then developed a bit of horizontal instability and weave. After that a decisive 60-cycle hum appeared in the video. One by one, he began exchanging tubes, feeling sure that one of them had heater-to-cathode leakage and was causing the hum. After trying practically every tube, he was surprised to find the 60-cycle hum still existed. He looked for his tube checker and then remembered it was in his car about half a block away. He began a different approach.

Since there was horizontal instability and weave, he examined the horizontal sync separator stage. The schematic showed the AGC control to be in the cathode of this stage. He rotated the control. Even at the extreme setting, the signal gain was excessive. He began reading voltages. Instead

February, 1958 • PF REPORTER

# NEW!

## Simpson COLOR BAR GENERATOR MODEL 430

SINGLE MASTER CONTROL has all outputs pictured in color. Shows what you should see on TV screen.

HINGED SIDE PANEL opens for fine adjustments and maintenance. Allows use from shelf or bench.

**PROVIDES TRUE 100% SATURATED NTSC SIGNAL**—Here's the new color bar generator you've heard so much about. It's literally packed with features to save you time, to do more jobs, to operate simply. And what's more, Model 430 will service any color-TV receiver—past, present, or future. You'll find it to be the finest, most complete instrument of its type.

### IMPORTANT SPECIFICATIONS

**Exceptional Range of Outputs**—Y; chroma; color bar (8 bars simultaneously—color phase accuracy,  $\pm 5^\circ$ ); R-Y; B-Y; R-Y and B-Y simultaneously; I; Q; I and Q simultaneously; G-Y at  $90^\circ$  (demodulator color phase accuracy,  $\pm 3^\circ$ ); sync and burst; horizontal sync; high level 3.58 megacycle output; high level modulated RF output; positive or negative video output. 4.5 Megacycle (crystal controlled) marker for proper tuning.

**Chroma Level Switch**—0 db for checking older style receivers and some current models; -6 db for video check of newer receivers using vestigial IF alignment; -15 db for checking color sync lock under weak signal conditions. Variable chroma control position for other chroma levels.

**Color Bar Display Pattern**—Left to right: red, yellow, green, cyan, white, magenta, blue, black.

**Model 430**, complete with Operator's Manual and Leads . . . . . **\$395<sup>00</sup>**

See your Electronic Distributor, or write

## SIMPSON ELECTRIC COMPANY

5200 W. Kinzie St., Chicago 44, Ill.

Phone: EStbrook 9-1121

In Canada: Bach-Simpson Ltd., London, Ontario



WORLD'S LARGEST MANUFACTURER OF ELECTRONIC TEST EQUIPMENT

**XCELITE Hand Tools**  
**PREFERRED BY THE EXPERTS**

**Featuring QUALITY**

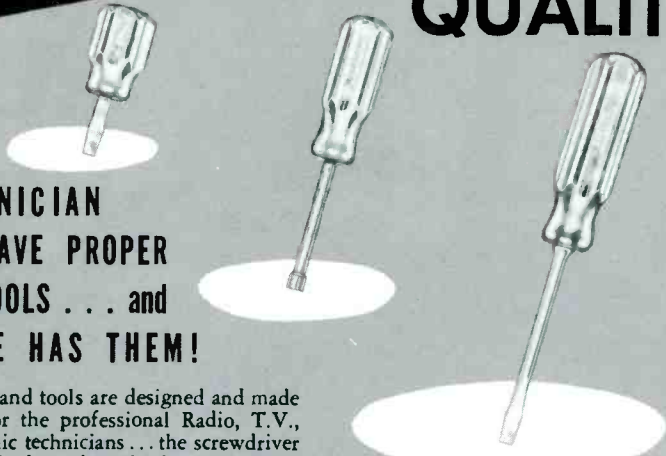

**A TECHNICIAN  
 MUST HAVE PROPER  
 HAND TOOLS . . . and  
 XCELITE HAS THEM!**

XCELITE hand tools are designed and made especially for the professional Radio, T.V., and Electronic technicians . . . the screwdriver blades are skilfully forged of A.I.S.I. 6150 Chrome Vanadium steel . . . the nutdriver sockets are "precision formed". Handles are of genuine XCELITE plastic, correctly shaped, full "man" size for perfect grip and balance.

Available in a variety of regular and special types and sizes for greater utility and performance . . . remember XCELITE for the finest tools first!

*Call or see your distributor today . . . get acquainted with XCELITE quality, also check the complete line of XCELITE quality tools for new items, or replacements that will help you do your job easier and faster.*

**XCELITE, INCORPORATED**  
 Dept. Q, Orchard Park, N. Y.  
 In Canada: Charles W. Pointon, Ltd.  
 6 Alcina Ave., Toronto, Can

**For Originality  
 LOOK TO XCELITE**

**SAVE  
 with  
 SECURITY**



Because Wright Wire Strand comes to you pre-measured and uncoils without snarling, it gives to you unique economy. Quality wire, perfectly stranded and heavily galvanized, the bright Wright way. **SAVE** with Wright.

Prompt deliveries from stocks in Worcester, Chicago, Atlanta, New Orleans, Houston, Dallas and Los Angeles.

**G. F. WRIGHT STEEL & WIRE CO.**  
 249 Stafford St. • Worcester, Mass.

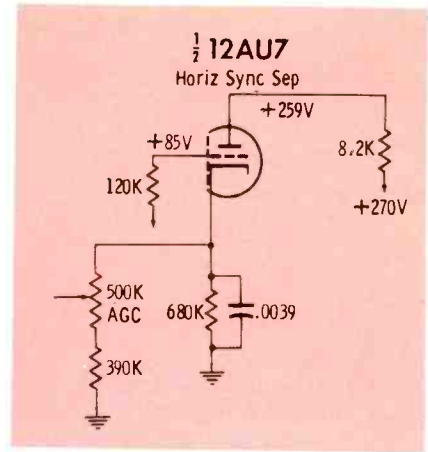

**Fig. 4.** The 8200-ohm plate load had increased to 200K, dropping the plate voltage and causing a weave that was accentuated by rotation of AGC control.

of the +259 that was supposed to be on the plate, he measured only a hundred. Measurement of the plate resistor indicated its value to be 200K instead of the prescribed 8,200 ohms. (See Figure 4.) He replaced the resistor and checked the performance of the set. Part of the weave and all of the horizontal instability had disappeared, and the AGC control worked normally again. But the 60-cycle hum in the video remained.

He began examining the tube socket bases to determine if one of them might in some way be defective, causing heater-to-cathode leakage. He examined and examined, yet the hum remained. Time kept right on moving and the repair bill kept getting higher and higher. As a last resort, he walked to his car and got his tube checker. In a few minutes he found the trouble. Both the first and second IF's had heater-to-cathode shorts. The substitution check didn't uncover this fact because he hadn't tried them simultaneously.

There is no room for anything but laboratory-type efficiency on your bench. Many service problems are so highly complex and require so much attention that great gobs of time are wasted unless your test equipment and technical information are at your fingertips when you need them. In the interest of eliminating inertia, you must set up completely for each new projected repair before you start, utilizing all your past experience, and being orderly and scientific in your analysis. ▲

# WESTINGHOUSE HELPS TV SERVICEMEN "GET A FAIR SHAKE!"

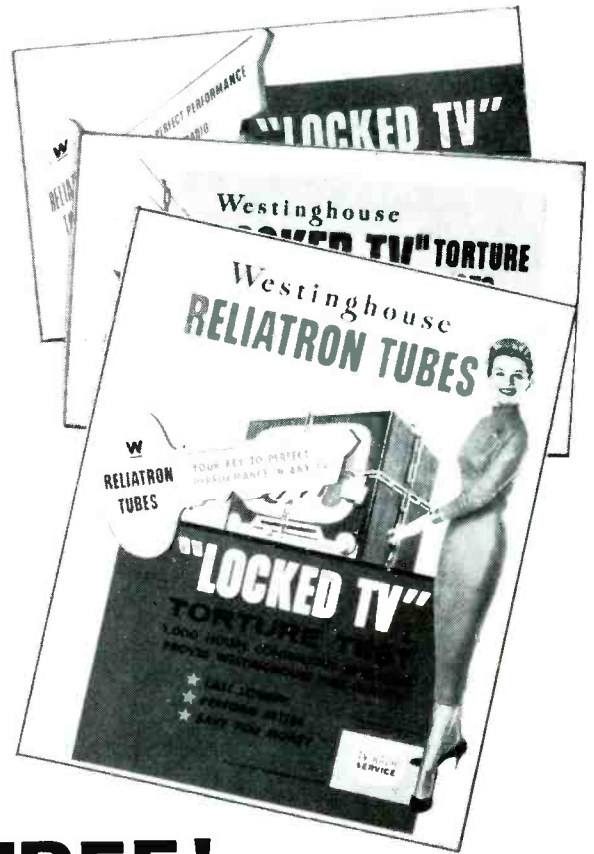
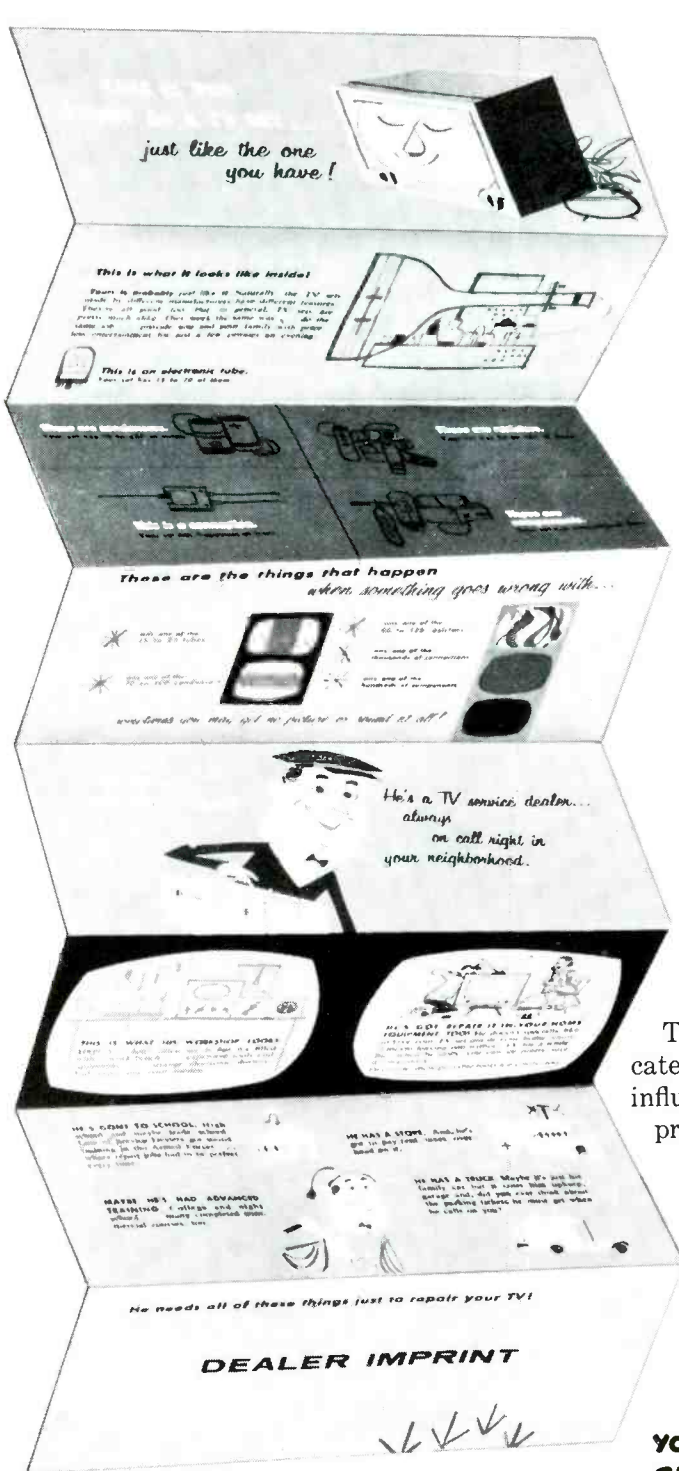

## FREE!

### "Build Consumer Confidence" Promotion

Today most people are unaware of the buy they get in TV and radio service. Now, Westinghouse helps you educate them with a program designed to win you friends and influence sales! You get a complete kit free! Keystone of the promotion is the mailing piece shown left. It describes how many hundreds of parts there are to check . . . how much knowledge it takes to be a serviceman . . . equipment costs . . . etc. It shows how TV servicemen, like doctors and lawyers, constantly study to keep up with advances. In addition you get window displays, streamers, everything you need—all free! Don't wait, put this promotion to work for you now . . .

**CALL YOUR WESTINGHOUSE DISTRIBUTOR**

**YOU CAN BE SURE...IF IT'S** **Westinghouse**  
Electronic Tube Division • Elmira, New York

# now.....automatic

# fine tuning

by Thomas A. Lesh

Although automatic frequency control circuits have been used successfully to counteract frequency drift in many other types of oscillators, the AFC principle has not generally been applied to the local oscillators of TV receivers. Perhaps the advantages of AFC for television tuners have been outweighed by the difficulties of obtaining a feedback signal that will accurately control the

oscillator frequency. This problem is complicated by the odd-shaped, wide-band response curve of the video IF and detector stages of a TV set.

Nevertheless, tuner AFC would offer one real advantage that has recently become very important—it would greatly simplify the operation of remote-control channel selectors. Consequently, a workable AFC system (automatic fine

tuning or AFT) has been commercially developed and is available this year.

This system, being used on Westinghouse Chassis V-2372/-82, is built around an unusual fine-tuning circuit incorporated in a new Standard Coil "Neutrode" tuner. This circuit, which includes a crystal diode, is shown in the upper left of Fig. 1. The diode and two 5-mmf capacitors are wired in

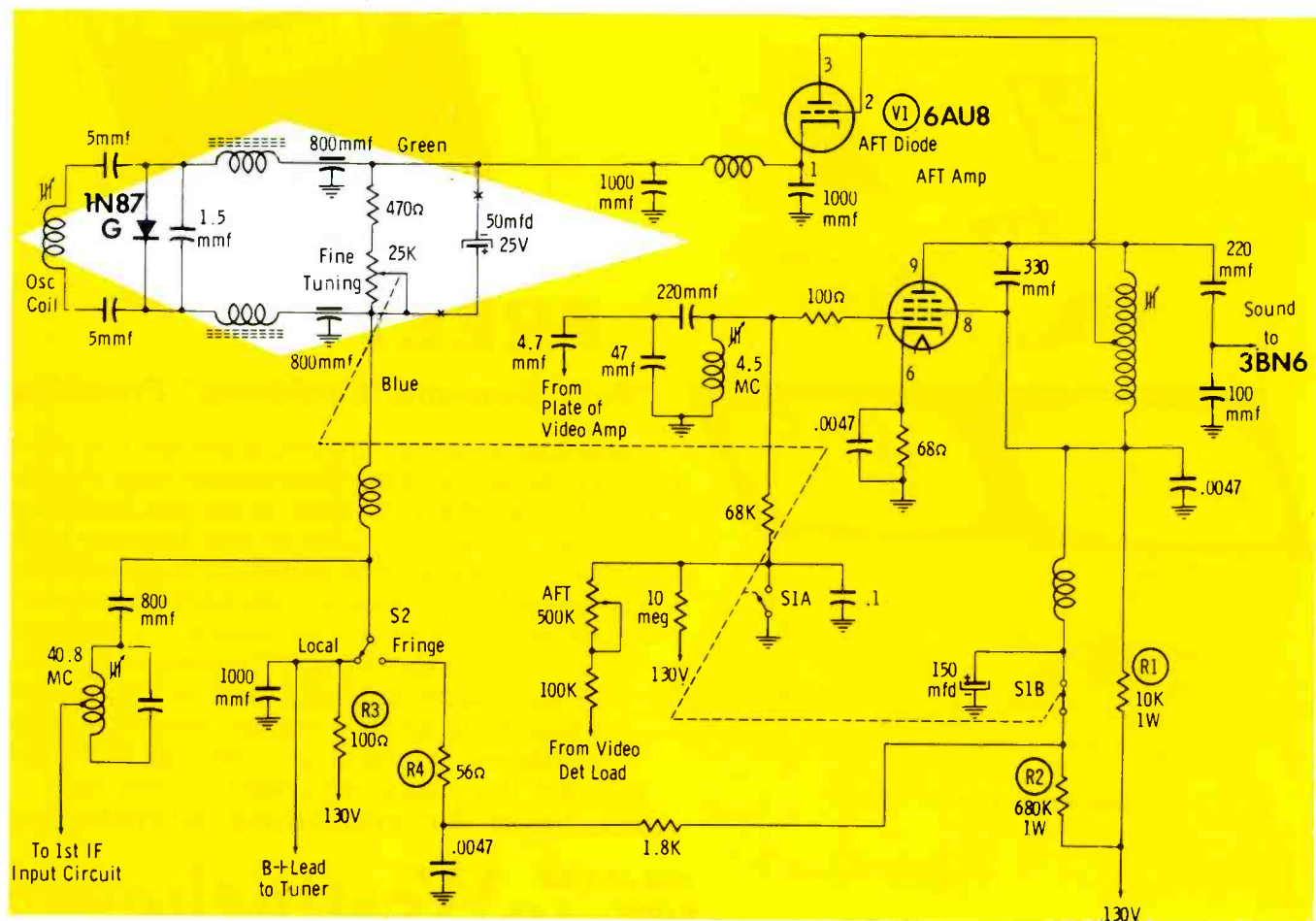

Fig. 1. Automatic fine tuning circuit of Westinghouse Chassis V-2372.



\$169.95 Net

## INDUCED WAVEFORM ANALYZER

MODEL 850

*Top-O'-Chassis Troubleshooting . . . greatest servicing advance in years!*

*Perfect for Portable TV*

Localizes defective stage in entire TV receiver in less than 5 minutes—without a direct circuit connection. Adapts any 'scope for spotting defects quickly by the modern, easy-to-use Induced Waveform Method. Unique, Phantom Detector Probe makes any tube a convenient test point. Just slip probe successively over each tube, then view and trace waveforms on scope from antenna thru RF, IF, audio, video & sync. Speeds servicing of TV, radios, amplifiers, instruments, industrial and laboratory equipment tool. Compatible for color. Phone jack for audio monitoring.

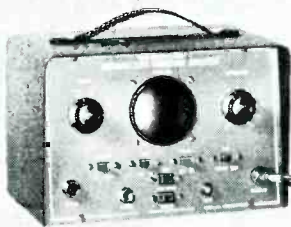

\$89.95 Net

## INTERMITTENT CONDITION ANALYZER

MODEL 828

*Pinpoints Intermittents without waiting...cooking...or freezing.*

Exclusive new principle makes any TV or radio super-sensitive to intermittents and noisy components . . . without waiting for breakdowns. Saves time and bench space. Cuts callbacks by detecting borderline components before they fail. Special Wintronix Probe and capacity pickup attachments let you hear intermittents thru built-in speaker.



\$79.95 Net

## AGC CIRCUIT ANALYZER

MODEL 825

*AGC Troubles Won't Fool You Any More!*

Saves hours by detecting hard-to-find AGC faults that may look like sync trouble, etc. Furnishes standard, adjustable r-f signal to antenna; monitors AGC action; checks AGC buss for opens and shorts; measures action of gated pulse systems; supplies AGC bias to restore operation by substitution.

# Wintronix ANALYZERS

## Electronic "Wonder Drugs" for Troubleshooting Pains



Here are the instruments you need to diagnose ailments fast and profitably in today's

complicated—often inaccessible—TV, radio & hi-fi sets.

These four Wintronix *Analyzers* swiftly turn wasted trouble-shooting time into profitable parts replacement time on more and more jobs. Obscure radio and TV faults get tracked down fast by Winston's specialized reference signals and measurements. Like X-rays, they quickly give a complete picture of circuit operation—at far lower cost, with fewer circuit connections, and with less set-up time than with separate conventional instruments.

Today, issue a prescription to yourself for a healthier servicing business—see and try these new Wintronix *Analyzers* at your local parts distributor or write for detailed literature.

## SWEEP CIRCUIT ANALYZER

MODEL 820

*Rapid, Dynamic Sweep Testing*

\$69.95 Net



Completely troubleshoots entire sweep circuits and restores raster by substituting for defective stage. Tests all flybacks and yokes for continuity and shorts. Self-calibrating. Compatible for color.

Model 915/960 Adapter converts Model 820 to a Sync Circuit Analyzer for signal substitution of vertical and horizontal sync pulses.

\$14.95 Net

# WINSTON ELECTRONICS INC.

4312 Main Street, Philadelphia 27, Pa.

**WILL YOUR REPLACEMENT**

**Fuse Resistor**  
**BURN OUT AGAIN?**

Another  
**Sencore**  
Time-Saver

Not if you use—  
**The NEW SENCORE**  
**"FUSE-SAFE"**  
CIRCUIT TESTER

Save costly call backs  
by testing the circuit  
before replacing  
fuse, fuse resistor or  
circuit breaker.



Individual scale for  
each value fuse res-  
istor — no inter-  
pretation, just read  
in red or green area.

★ Measure line current  
and up to 1100 watts of  
power at 115 volts using  
line cord and socket.

★ Two convenient current  
ranges — 0 to 2 amps and  
0 to 10 amps. Test leads  
clip in place of fuse or fuse  
resistor.

★ 5 ohm, 10 watt resistor prevents TV circuit  
damage and simulates operating conditions.

As Recommended by Leading Manufacturers

Mfg. by **SERVICE**  
**INSTRUMENTS CORP.**  
171 OFFICIAL RD., ADDISON, ILL.

Cut out this ad now for further information



**\$8.95**  
DEALER NET  
MODEL FS-3  
AC-DC or both as  
needed for Fuse  
Resistor Circuits

series across the oscillator tank circuit. On positive peaks of oscillator voltage, the diode conducts and charges the capacitors.

If no discharge path exists across the crystal during its non-conducting interval, the capacitors will attain and hold a peak charge which will cause the crystal to cease conducting entirely. Then the fine-tuning circuit will appear open and will have no effect whatsoever on oscillator frequency. On the other hand, the crystal will conduct periodically if a portion of the charge which it places on the capacitors leaks off through some discharge path. In this case, the crystal circuit will act as a capacitive shunt across the oscillator tank and will lower its resonant frequency.

A "minimum" discharge path is provided in the circuit of Fig. 1 by the 1.5-mmf capacitor across the crystal, and variable circuits outside the tuner can also be placed in parallel with the crystal to increase the discharge rate of the 5-mmf capacitors as needed. The simplest of these external circuits is a potentiometer used as a front-panel fine-tuning control. When this is turned to a lower resistance setting, the time constant of the fine-tuning circuit is reduced and the capacitors discharge to a greater degree between charges. The crystal therefore conducts more heavily on positive peaks of oscillator signal, the effective shunt capacitance is increased, and oscillator frequency is shifted downward. Incidentally, the potentiometer may also be located in a remote control box and connected to the TV receiver by a cable.

If the variable resistance in series with the 5-mmf capacitors were replaced by an external source of variable current, it could also be used to control the oscillator frequency. In fact, that is the operating principle of the AFT circuit.

Current flow through the AFT loop is regulated by conduction of the diode-connected triode section of a 6AU8 tube. In turn, the diode is controlled by a signal derived from the video detector and amplifier outputs. A pentode AFT amplifier (the other section of the 6AU8) is used to convert the

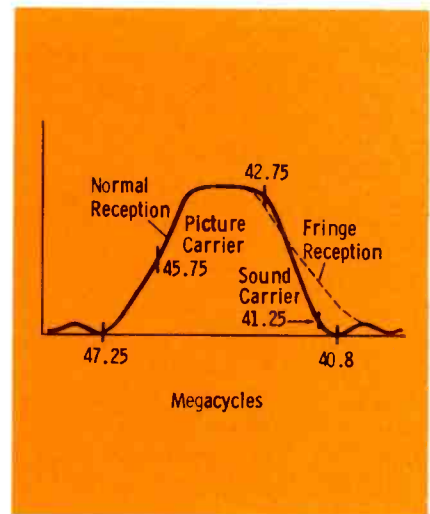

Fig. 2. IF curve of receiver with AFT.

video signal into a form usable by the diode. That is, it senses whether or not the picture and sound carriers in the IF output signal are at the correct points on the IF response curve and "informs" the diode of the amount and direction of any error. The pentode serves also as a sound IF amplifier. Connected to its plate is a capacitive voltage divider from which a 4.5-mc sound signal is fed to a 3BN6 detector.

The IF response curve of the AFT-equipped set, shown in Fig. 2, is slightly different from that of a conventional receiver for the sake of more efficient AFT operation. The picture-carrier side of the curve is normal, with the 45.75-mc marker approximately at 50%, but the sound trap is not tuned exactly to the sound-carrier frequency of 41.25 mc as is usually the case. Instead, it places a "notch" in the response curve at 40.8 mc, and the sound carrier comes in on the steep side of the curve. This carrier position has two advantages:

1. A slight drift of oscillator frequency in either direction will cause a linear shift in the frequency of the IF sound carrier and thus a linear change in correction voltage. The IF carrier frequency can shift either up or down from its correct position. This will conveniently indicate whether the oscillator is drifting too high or too low.
2. The steepness of the curve insures a relatively great

**NEW NEW**

**TELEVISION  
TUBE-SAVER**

Complete  
List Price **\$4.95**



Model 125, 100-250 Watts  
117 Volts AC or DC

**Stop Annoying Call-Backs**

By absorbing damaging in-rush current so destructive to television and Hi-Fi tubes, the Tube-Saver eliminates 9 out of 10 callbacks by more than tripling the life of all tubes . . .



Model 101-2—100-300 watts, **\$1.85** List

**WUERTH SURGISTOR**

A new component easily installed by a serviceman to reduce call-backs by eliminating surge current damage to television and Hi-Fi tubes.

Already available from:

Chicago . . . . . Allied Radio  
New York . . . . . Lafayette Radio  
**AND OTHER DISTRIBUTORS  
THROUGHOUT THE COUNTRY**

**Wuerth Tube-Saver Corp.**

9125 Livernois Ave., Detroit 4, Mich.



change in the sound-signal output at the video detector for even a slight shift in oscillator frequency. This provides greater AFT sensitivity than would be realized if the sound carrier were riding in and out of a shallow notch.

Since the amplitude of the sound carrier is higher than it is in most receivers, sound interference in the video signal might be expected; but this is taken care of by keeping the carrier quite far down on the side of the curve and also by the use of a 4.5-mc trap in the picture tube input circuit.

As shown by the dashed-line portion of the curve in Fig. 2, the response can be slightly modified for fringe-area operation. This special case will be explained after the normal operation of the circuit has been fully described.

#### Details of Operation

When the front-panel fine-tuning control is rotated to the maximum-resistance position (fully counterclockwise), the AFT is activated by two switches ganged with the control. SIA opens a ground connection in the grid circuit of the AFT amplifier, allowing a signal to arrive at the grid from the video detector load circuit, and SIB inserts a 680-ohm resistor R2 in parallel with R1, the 10K-ohm plate-load resistor of the pentode.

With the AFT circuit functioning but no signal applied to the receiver, the AFT diode does not conduct; therefore, the fine-tuning control and its series resistor form the only external load on the crystal-diode circuit. Under these conditions, the oscillator operates approximately 1.5 mc above the "correct" frequency, and the crystal circuit generates a DC potential of -6 to -8 volts as measured across the fine-tuning terminals of the tuner. This voltage plays a part in determining the bias on the diode tube.

Observe that the plate and cathode of the diode are both returned to the 130-volt B+ bus instead of ground. On the cathode side, the crystal voltage and the drop across R3 are series aiding, making the cathode less positive than B+. Opposing these voltages is the drop across the plate-load



## The new RCA WT-110A AUTOMATIC ELECTRON TUBE TESTER

*for Speedy,  
Automatic Testing*

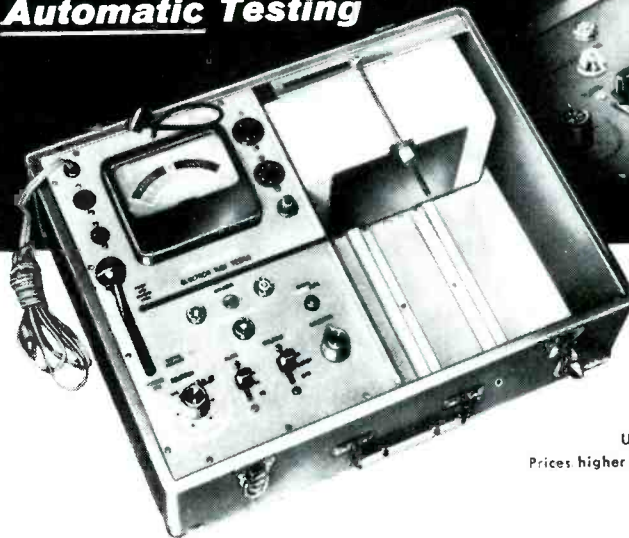

**\$199.50**

USER PRICE (optional)  
Prices higher in Hawaii and Alaska

Insert punched card... pull power lever... read meter... fast as A-B-C. You save time because the WT-110A sets up all pin connections and tube-testing voltages *automatically* by means of punched, computer-type test cards.

- checks tubes for transconductance, gas, shorts, and leakage between elements.
- virtually obsolescence-proof. Do-it-yourself card punch and unpunched cards available for preparing your own test cards... keeps card file up-to-date economically.
- automatically sets up ALL socket connections, and ALL operating voltages—such as heater, signal, plate and screen and bias voltages (both fixed and cathode).
- automatically selects correct test conditions from 220 different heater voltages (from 0.1 volt to 120 volts) at currents up to 4 amps., 10 bias voltages, and 11 values of cathode resistance.
- tubes, such as rectifier types, tested under heavy load currents (up to 140 ma per plate).
- high-and-low sensitivity ranges for gas and leakage tests.
- 12-volt plate and screen supply for testing new auto-radio tubes.
- meter protected against burnout.
- test card provided for checking instrument.
- 239 pre-punched cards supplied with instrument, cover 95% of currently active TV tubes. Pre-punched accessory cards available.

**Now... at your RCA Distributor!**



**RADIO CORPORATION OF AMERICA**  
Electron Tube Division  
Harrison, N. J.

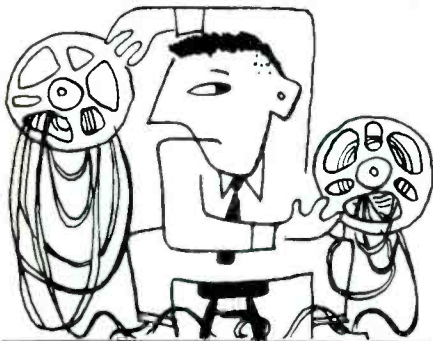

get the straight facts  
on current model  
**TAPE RECORDERS**

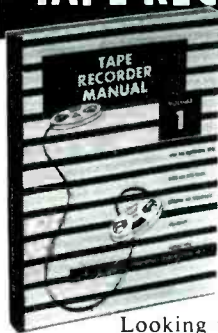

*Howard W. Sams*  
**"TAPE  
RECORDER  
MANUAL"**  
VOL. 1

Looking for unbiased facts about various makes of tape recorders? This is the book that shows you the "inside story"—no sales pitches—just down-to-earth descriptions and illustrations of all mechanical and electrical features and how they work.

Sams "Tape Recorder Manual", Vol. 1, covers tape recorders and players produced in 1956 and 1957 by the following manufacturers: Ampex, Bell-Sound, Columbia Records, Ekotape, Ellamac, Magnecord, Silvertone, V-M and Wilcox-Gay.

Presents complete authoritative data on each model: exclusive "exploded" views of all mechanical parts; details of each adjustment and control; complete operating instructions; photographs of all external and internal parts; complete wiring diagrams and replacement parts lists. Includes tips on how to avoid and cure troubles such as wow, flutter, failure to erase and others. Shows you how to disassemble and assemble each recorder and how to check for source of trouble. A valuable book for everyone interested in tape recorder design, operation and servicing. 148 pages; 8½ x 11"; profusely illustrated.

PRICE **\$295**  
ONLY

SEE THIS AUTHORITATIVE BOOK  
AT YOUR SAMS DISTRIBUTOR OR  
MAIL COUPON TO HOWARD W. SAMS



**FREE TRIAL COUPON**

Howard W. Sams & Co., Inc., Dept. 3-BB8  
2201 E. 46th Street, Indianapolis 5, Ind.

Send me Sams "Tape Recorder Manual" Vol. 1, for 10 days FREE examination. In 10 days I will pay for the book, plus small delivery cost, or return postpaid. We pay delivery costs if you remit with this coupon, same return privilege.

Name.....

Address.....

City..... Zone..... State.....

(outside U.S.A. priced slightly higher)

circuit of the AFT pentode, which makes the diode plate also less positive than  $B+$ . The plate-load drop is relatively large in the absence of an input signal because the pentode is conducting heavily. As a result, the diode plate is from 0.5 to 1.5 volts negative with respect to the cathode, and the AFT loop is an open circuit.

Reception of a signal triggers an immediate and drastic drop in oscillator frequency. Since the initial frequency is 1.5 mc too high, the sound carrier will fall at 42.75 mc instead of the normal 41.25 mc. As shown in Fig. 2, this point is near the top of the response curve, and a strong sound-carrier signal will therefore appear in the video detector output circuit. This signal develops a negative DC output of several volts, which is passed along to the grid of the AFT amplifier for the purpose of increasing the bias on this tube. AFT plate current decreases (or is cut off entirely), and the voltage drop across the plate load becomes less. The plate voltage of the diode then shifts in a positive direction and the diode conducts heavily, loading the finetuning circuit and rapidly lowering the oscillator frequency.

At first, the picture-carrier signal does not get through to the video detector at all, because its initial frequency of 47.25 mc is down in the "notch" created by an adjacent-channel sound trap. When the oscillator frequency begins to shift, the picture carrier rises toward its normal position on the slope of the response curve. At the same time, the sound carrier drops down the steep slope on its side of the curve. The average DC voltage at the detector then becomes somewhat less than it was at first, but a 4.5-mc beat begins to be developed because both carriers are present. This 4.5-mc signal takes over a large part of the job of "zeroing in" the local oscillator on the correct frequency and keeping it there.

The beat signal is amplified by the video output stage and then applied to the grid circuit of the 6AU8 pentode section—which, by the way, is tuned to 4.5 mc. The pentode provides additional gain, and the AFT diode conducts on positive swings of the strong sig-

nal which appears in the plate circuit. The system automatically seeks a point of equilibrium which is determined partly by the amplitude of the 4.5-mc signal and partly by the DC grid bias derived from the video detector output. In other words, the diode automatically conducts just enough to maintain the oscillator frequency at the right value. If the oscillator drifts too high, the periods of diode conduction are lengthened and more correction current is supplied; on the other hand, a decrease in oscillator frequency causes shorter periods of conduction and forces the control circuit to "let up" slightly.

**Fringe-Area Operation**

AFT-equipped Westinghouse sets have provisions for adjusting system performance for either local or fringe-type reception of individual channels. A switch (S2 in Fig. 1) is operated by 12 plastic sliders on a "program wheel" fastened to the automatic tuning motor. Each slider may be placed either in an outer "local" position or a middle "fringe" position, as well as a third position which causes the motor to bypass the channel entirely.

The object of the switch circuit is to alter the oscillator frequency for fringe reception in such a way that the picture carrier will come in at a higher point on the response curve, giving every possible bit of picture gain. At the same time, the low-frequency side of the curve must be modified as shown by the dashed line in Fig. 2, so that the sound carrier will remain on the slope rather than dropping into the 40.8-mc "notch." This is essential to maintain good AFT action and adequate sound amplitude.

The curve shape is modified by

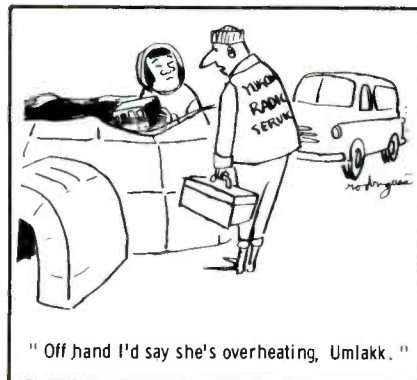

"Off hand I'd say she's overheating, Umlakk."

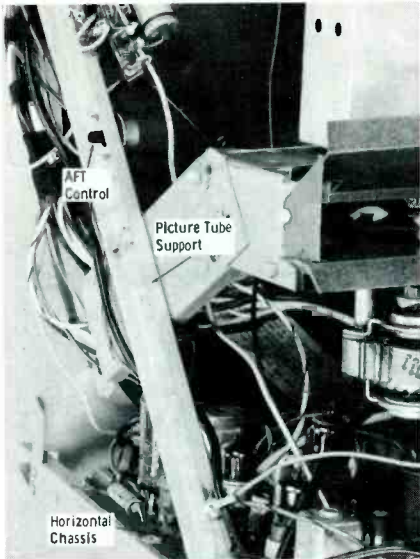

Fig. 3. Potentiometer for AFT adjustment.

disabling the trap. The AC ground connection through the 1,000-mmf capacitor on the "Local" side of S2 is removed, and a connection via a .0047-mfd capacitor and the 56-ohm resistor R4 is substituted. As a result, the dip in the curve at 40.8 mc is replaced with a gradual slope.

To utilize this new curve properly, the picture and sound carriers must be decreased in frequency. For example, the IF picture carrier should be moved toward 45.0 mc to put it near the top of the curve. Since the oscillator operates above the incoming signal, the desired effect (i. e., lowering the difference frequency fed to the IF strip) is secured by reducing the oscillator frequency. The simplest way of doing this is to make the AFT diode conduct more heavily. S2 steps up diode conduction by removing R2 and R3 from the circuit loop which establishes the DC potential on the diode. The net effect of eliminating these resistors is an increase of several volts in the positive potential on the diode plate. In summary, the different circuit constants in "Fringe" position cause the AFT system to stabilize at a lower oscillator frequency.

#### AFT Off

The AFT system is disabled simply by rotating the fine-tuning control clockwise. S1A then closes and shunts to ground the connection between the video detector and the AFT pentode; in addition,

S1B opens and removes R2 from the AFT plate-load circuit. Since the total load resistance is increased, the plate voltage of both the pentode and the diode will drop from over 100 volts to 60 volts or less. This strongly biases the diode in the nonconducting direction, and it also causes the pentode to operate as a limiter for improved noise immunity of the sound signal.

#### Servicing Pointers

Since any voltage unbalance in the AFT loop will render the system unable to pull in a clear picture, a control is provided so that the system can be brought exactly into balance. This potentiometer is located electrically in the grid circuit of the AFT pentode. Mechanically, it is located on one of the support rails that rise above the horizontal chassis, as shown in Fig. 3. Before attempting to adjust this control, the technician should make sure that S2 is not being thrown into the "Fringe" position on some channels by mistake. The condition of the 6AU8 should also be checked.

In most cases of trouble involving the AFT loop itself, manual fine tuning will still operate normally. If it does not, the crystal circuit or other components in the tuner should be checked.

By the way, care should be used in probing around the AFT system, since all parts of it except the pentode grid circuit are more than 100 volts above ground.

The purpose of the chokes connected to the crystal diode terminals is to keep RF inside the tuner and thus prevent oscillator radiation.

The AFT can sometimes compensate for tilt or distortion in RF-IF response. For example, a sag on the picture-carrier side of the curve will cause the AFT to shift its equilibrium point to a lower frequency in an attempt to move the carrier higher up the curve. This self-correcting characteristic of the AFT system is by no means foolproof, however. The technician should pay careful attention to proper alignment of an AFT-equipped receiver, being especially sure to tune the traps in the IF strip to the correct frequencies. ▲

Eliminate call backs...  
use dependable,  
industry-preferred...



3 WATT SIZE  
5/16" x 1/4"

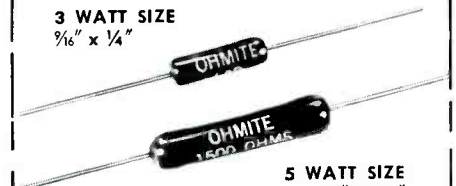

5 WATT SIZE  
1 1/8" x 1/32"

#### AXIAL-LEAD RESISTORS

Vitreous-enameled, power-type, axial-lead units designed to withstand high temperatures.



#### LITTLE DEVIL® COMPOSITION RESISTORS

Meet all MIL-R-11A requirements. Available in 1/2, 1, and 2-watt sizes in all standard RETMA values.

#### BROWN DEVIL® RESISTORS

Vitreous-enameled.  
In 5, 10, and 20-watt sizes.



#### TYPE AB POTENTIOMETERS

Resistance material is solid-molded, noise-free. Rated at 2 watts.

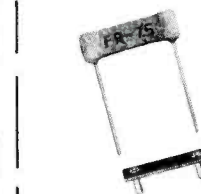

#### FR-7.5 FUSE RESISTOR

For easy replacement in many television receivers. 1 1/2" Tinned wire leads.

WRITE FOR STOCK CATALOG

**OHMITE®**  
DEPENDABLE RESISTANCE UNITS

OHMITE MANUFACTURING COMPANY  
3644 Howard Street • Skokie, Illinois

# troubleshooting with George

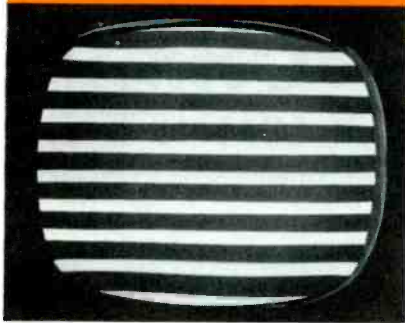

Fig. 1. The pattern on the screen was accompanied by motorboating sound.

Well, it seems we've had some pretty bad winter weather since we last poked our nose into George Fleiback's service shop. George evidently survived the Christmas and New Year holidays, so let's drop in on the old investigator and see if he's got any new electronic mysteries puzzling him.

It looks like he's working on an antique of some sort—yep, a 17" TV chassis about 6 or 7 years old. How about that? A power transformer and no printed wiring! Well, anyway, George has just completed one repair on the chassis but seems to have an additional problem. He had pulled the chassis for loss of vertical sweep and found the trouble to be a shorted capacitor in the output stage. Replacement of the cap had restored the sweep; however, the customer had also complained of a loud noise every time the set was first turned on. As we pull up our

## the case of the strange warm-up

by Les Deane

imaginary stool beside George, we find him investigating this second trouble symptom which apparently had no connection with the first.

George permitted the tube filaments to cool off for about ten minutes, then turned the set back on. Before the raster filled the screen, he detected a slow motorboating sound in the speaker. As the set warmed up, the sounds became higher in pitch and several dark sound bars appeared in the raster. (Fig. 1). The bars kept increasing in number as the sound gradually changed from a motorboating hum to a high-frequency squeal. This seemed to last about a full minute—then, suddenly, the picture and sound returned to normal. George found the symptom present on all channels and noted that the audible signal strength was affected by the volume control. The trouble occurred only when the set was first turned on, providing it had cooled off for

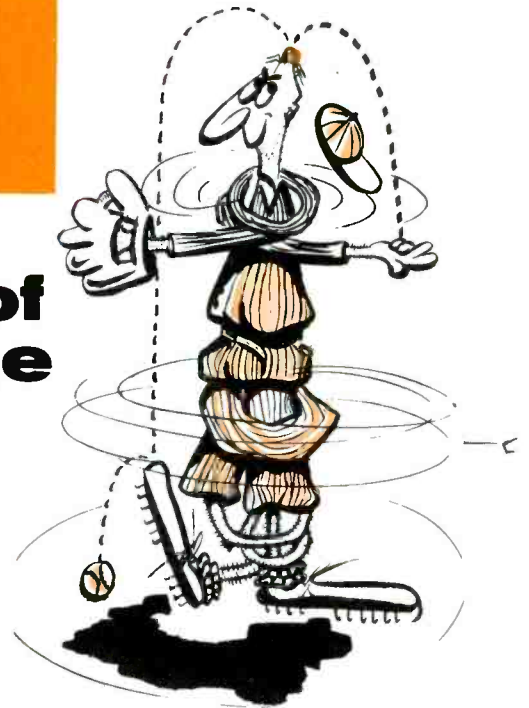

ten minutes or more. Furthermore, it seldom lasted longer than 60 seconds.

Our sleuth thought he would be systematic about his approach and attempt to corner the criminal by first isolating the source causing the disturbance. He figured that this somewhat steady build-up of energy might be caused by a defective capacitor or possibly one of the sweep circuits oscillating during warm-up. Since the tube filaments were wired in parallel, it occurred to him that he might locate the signal source by pulling tubes in various sections of the receiver. He knew, regardless of how he approached the problem, that it was going to be a time-consuming process because the set had to cool off each time he wanted to check for the symptom.

George decided to see if the unwanted signal was passing through the IF strip, so he removed the first video IF amplifier. When he fired up the set to check the symptom again, he did not detect any noise in the speaker nor did he notice any sound bars on the screen. He quickly turned the set off, replaced the IF tube, and pulled the RF amplifier from the tuner. Again turning the set on, George found no evidence of the trouble. He replaced the RF tube with a new one, but without any luck. Scratching his head, he

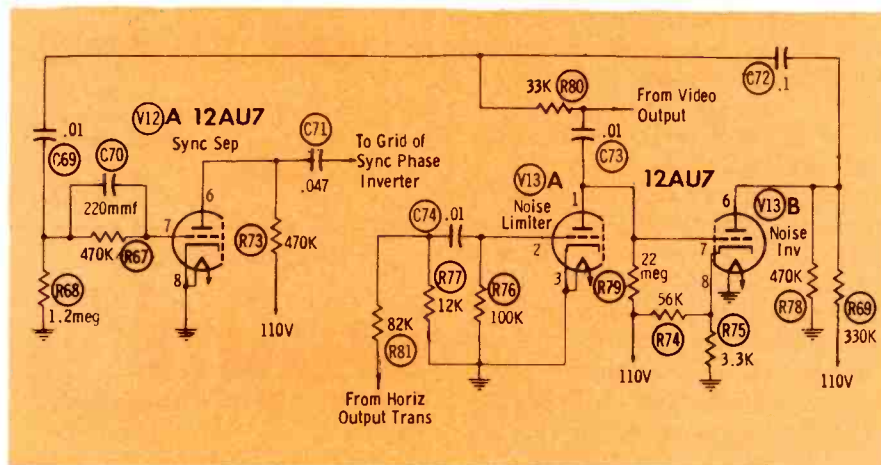

Fig. 2. Schematic of the complex sync circuit encountered in Case No. 2.

*Dave Rice's*  
**OFFICIAL  
 ORDER BOOK**  
 for every TV-Radio  
 service call

**CONVENIENT!  
 EASY TO USE!**

Simplify your record-keeping with these convenient triplicate forms. They serve as order form, invoice and office record, with spaces for complete information on every job. Separate listings for receiving tubes, picture tubes, parts, serial numbers, labor and tax charges, etc. 75c a book, \$6.50 for money-saving dust-proof box of 10.

*In stock at your distributor*

**ELECTRONIC PUBLISHING CO. INC.**  
 180 North Wacker Drive Chicago 6, Illinois



**MAGNA-LITE\***

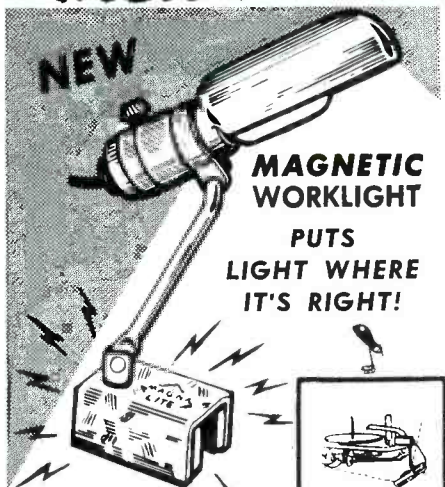

**MAGNETIC  
 WORKLIGHT  
 PUTS  
 LIGHT WHERE  
 IT'S RIGHT!**

**HUNDREDS OF USES!**

Because of Magna-lite's new magnetic principle, you get light into corners... underneath... on the sides... light you need for proper illumination of your work. Holds firmly until you take it off... no chance of damage from falling. Hang it on the wall... set it on your work bench... take it with you on house calls. Gives light without excessive heat.

**ONLY \$3.95**



Another Serviceman-Designed Product from  
**R-COLUMBIA**  
 PRODUCTS, Inc. Highwood, Ill.  
 \*TRADEMARK

thought to himself, "The signal must be passing through the entire set... I wonder if some stage is radiating a signal that's being picked up by the antenna or tuner lead-in?" George's suspicions were even stronger after he disconnected the antenna and found that the sound and video symptoms were much weaker.

After looking for missing tube shields, checking lead dress, and making sure the picture tube coating was properly grounded, he decided to kill the horizontal sweep to see if it might be the source of energy causing the trouble. Removing the horizontal oscillator tube, George again applied power to the chassis. The trouble remained, however, so he proceeded to disable the vertical sweep circuit. This also led to no new clues, and our private-eye at this point was somewhat stumped.

George next debated whether or not to use his scope to try and trace the undesired signal or to continue eliminating as many possible sources of trouble as he could. As it turned out, several warm-up periods later, George corrected the trouble by merely replacing the 6J6 mixer-oscillator tube in the tuner. During warmup, the tube would evidently develop an internal oscillation between triode sections.

Later, George found that it was impossible to detect this condition with a tube checker. The thing that really threw him was when he removed the RF amplifier and found that the symptom vanished—then too, when he disconnected the antenna the symptom became considerably weaker. These conditions were apparently brought on by the disturbance of a regenerative loop within the tuner.

Remember George, when both picture and sound are affected, always substitute all tubes in those stages passing both picture and sound signals.

**The Case of the Shifty Picture**

While we're comfortably seated, let's stick around and see what George finds wrong with another chassis he's just removing from its cabinet. The set looks like a '54 or '55 model with a 21" tube. It seems Sherlock was called in on the case to solve a mystery

**NOW... Check Vibrators  
 In ANY Tube Checker**

*Another  
 Sencore  
 Time-  
 Saver*

**"VIBRA-  
 DAPTOR"**

MODEL  
 VB-2

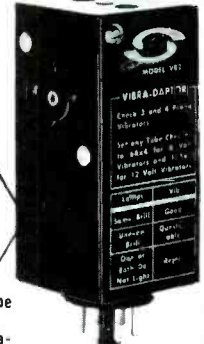

**2 ADAPTORS  
 IN**

**Checks Both Three  
 and Four Prong  
 Vibrators**

- Merely plug into any tube checker. Set for 6AX4 (or 6SN7) for 6 Volt Vibrators and 12AX4 (or 12SN7) for 12 Volt Vibrators.
- Two lamps viewed through top of adaptor indicate whether or not vibrator needs replacing.
- Rugged — Made of steel.
- Replaceable but unbreakable #51 indicating Lamps.
- Operates easily with Sencore LC2 Leakage Checker.
- Complete instructions screened on front.

**ONLY \$275**  
 DEALER NET



MANUFACTURED BY

**SERVICE**  
 INSTRUMENTS CORP.

171 OFFICIAL RD. ADDISON, ILL.

At leading distributors everywhere

**POPULAR  
 SENCORE  
 PRODUCTS**

- Translator Tester
- Leakage Checker
- Filament Tester
- Handy "36"
- Vibra-Daptor



**all EYES  
 are on MERIT**

...watch for new  
 catalog No. 5811  
 it's terrific!



**"COMPARE IT  
 WITH MERIT"**

**MERIT COIL & TRANSFORMER CORP.**  
 4427 N. CLARK ST., CHICAGO 40, ILLINOIS

# SUPER RELIABLE!

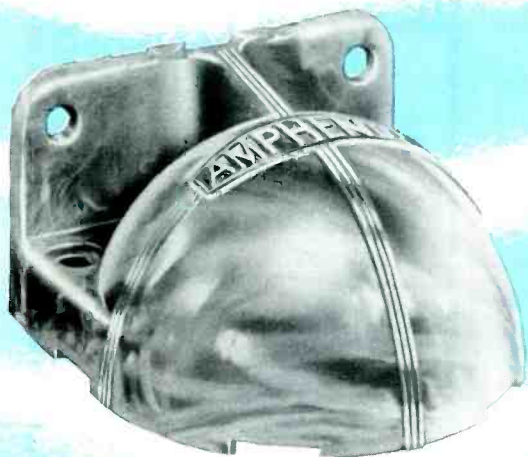

## TV Color COUPLER

New design ideas in performance, appearance and mounting make AMPHENOL's Color-Couplers best for coupling of Color and/or Black & White TV sets as well as FM radio. Incorporating a super reliable resistive network, Color-Coupler provides

1. **Effective isolation**
2. **Low insertion loss**
3. **Almost perfect impedance match**
4. **Flat signal response (a must for Color TV)**
5. **Built-in twin lead strain relief**
6. **Horizontal or vertical mounting**

*To Help You Merchandise this superior coupler AMPHENOL provides a free 3-color counter-top display. Included with each standard package of 9 114-097 2 set Color-Couplers, this eye-catching display mounts 6 Color-Coupler cartons for reach-and-buy action!*

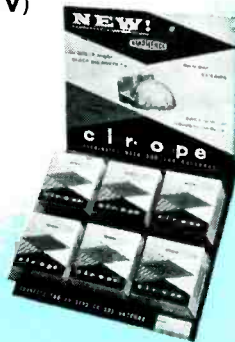

**Color-Couplers are also available as three and four set models. Your AMPHENOL Distributor has all the data.**

AMPHENOL ELECTRONICS CORPORATION  
chicago 50, illinois

involving poor horizontal phasing. In the customer's home, George had weighed the evidence carefully. He observed that after the set had been on for a few minutes, the picture would tend to shift horizontally. Sometimes the symptom showed up and other times it didn't—but when it did, the picture or video information would move to one side only an inch or so. The owner mentioned that it had acted this way from time to time ever since they had the set.

George had already performed various routine checks such as substituting tubes, looking for burnt or damaged components, etc. Now we find him searching for clues with his trusty scope. With a schematic of the receiver laid out in front of him, George first took a look at the horizontal sync pulses fed to a diode phase detector in the AFC stage. The shape of the pulse appeared satisfactory and its amplitude seemed up to snuff, so he next investigated the sawtooth signal fed back to the AFC stage from a winding on the flyback transformer. This waveform also compared to that given in the service data, thus leaving George a little disheartened. (He always gets the tough ones.)

After spending a good half hour measuring voltages, resistances, and replacing two capacitors in the horizontal AFC-oscillator section, George turned his attention back to the sync stages (see the partial schematic in Fig. 2). In the process of checking voltages, George removed the noise limiter-inverter tube V13 from its socket. His eyes suddenly lit up, replacing a somewhat preoccupied stare, as he noticed the picture shift back to its normal position while he still held the 12AU7 in his hand. "Let's see now," he said to himself as he referred to the schematic, "the video signal is coupled to the sync separator through C69 . . . then sync is taken off the plate and fed to the phase inverter stage by C71—hum-m . . . the circuit seems to be independent of V13. Maybe I've got troubles in that noise limiter or inverter section?" George tried two other new 12AU7's in the suspected circuit, but the trouble symptom still remained.

# Grips the screw!

Drives it too!

**Quick-Wedge  
SCREW-HOLDING  
SCREWDRIVER**

2" to 14" blades, 4 bit sizes.  
Available with shockproof  
plastic covered tubing  
Unconditionally guaranteed



**ASK FOR IT AT YOUR DEALER**

Kedman Co., 233 South 5th W.,  
Salt Lake City, Utah

## looking for the right replacement?

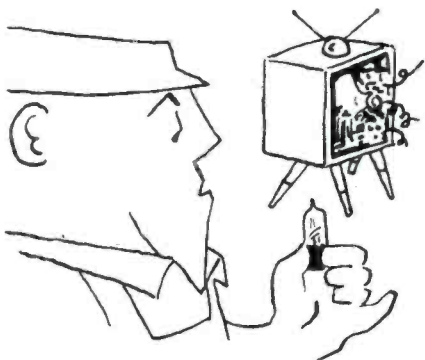

you'll find it  
faster in the

# MASTER

new 1958 edition—world's largest  
electronic catalog only \$3.50 at  
your local parts distributor—now

**THE RADIO-ELECTRONIC MASTER**  
60 MADISON AVE., HEMPSTEAD, N. Y.

After a complete waveform analysis and voltage-resistance check failed to reveal the criminal, our boy was almost ready to turn in his badge. Pausing for a moment, he thought to himself, "I wonder if that circuit was designed just for certain signal areas or something?" Thumbing through the back pages of the service folder, lo and behold, George ran across a number of production changes. In bold print and even accompanied by a partial schematic, he found one concerning the very trouble he was encountering.

Making recommended changes, which included decreasing the value of C69 to .0047, changing R68 to a 2.7 meg, reducing R69 to 180K, removing R74 and R75 entirely, and connecting the cathode of the noise inverter triode to a voltage-divider network in the cathode circuit of the horizontal output stage, George restored the set to normal operation.

Actually, the noise inverter tube V13B had not been biased accurately in the original design. The stage would apparently conduct during horizontal sync time, thus resulting in a partial cancellation of the desired or received horizontal sync signal. Instead of the oscillator triggering continuously on the leading edge of the pulse, it often became controlled by a portion of the trailing edge which produced a slight shift in picture phase.

You may have criticized George in your own mind for his stumbling attempt to solve the case without first consulting all of the information at his disposal, but can't each one of us recall similar instances in our own experiences? ▲



"Well, one good thing. We won't be bothered by any annoying callback."

# PROTECT ALL ELECTRONIC TUBES

WITH

# ATR

## Electronic Tube PROTECTOR

Designed To Protect All Electronic Tubes  
in TV or Hi-Fi Sets, Amplifiers, and Similar  
Electronic Equipment. Will Double or Triple  
Tube Life Including Picture Tubes.



ATR Electronic  
Tube Protector  
Wall Model 250

List Price \$495—DEALER NET PRICE \$330



ATR Electronic  
Tube Protector  
Floor Model 300

List Price \$695—DEALER NET PRICE \$463

ATR Electronic Tube Protectors will double or triple the life of all electronic tubes including picture tube in TV or Hi-Fi Sets, Amplifiers, Electronic Organs, and other similar electronic equipment. The ATR Electronic Tube Protector utilizes a thermal cushion-action principle which also protects all other components by eliminating initial damaging surge currents. The ATR Electronic Tube Protector can be used with any electronic equipment having input wattage of 100 to 300 watts.

**SEE YOUR JOBBER OR WRITE FACTORY**

✓NEW MODELS ✓NEW DESIGNS ✓NEW LITERATURE  
"A" Battery Eliminators, DC-AC Inverters, Auto Radio Vibrators

**ATR**

**AMERICAN TELEVISION & RADIO CO.**  
Quality Products Since 1931  
SAINT PAUL 1, MINNESOTA, U. S. A.

# RADIART VIBRATORS



## Consistently dependable power

Next time an auto-radio vibrator replacement is called for, try Radiart. There's a complete line for all 6-volt and 12-volt applications. And no waiting for the type you want, because your local Radiart Distributor maintains a full stock for your convenience. Ask him for your free copy of the Radiart Vibrator Replacement Guide, or write to Dept. S-1, The Radiart Corporation, Indianapolis 5, Indiana.



# RADIART TOBE Vibrators

Old Hands at Dependability

## Shop Talk

(Continued from page 10)

because, to low and medium frequency voltages, the earth is a fairly good conductor and a horizontally polarized wave has its electric field parallel to the ground. The conducting earth would short-circuit the field, preventing its propagation for any appreciable distance.

The surface wave, as it travels, induces charges in the earth. The periodic change in wave polarity causes the charge concentration to vary from point to point. These concentrations can vary only by having electrons flow from point to point, and this in turn constitutes a current. Since the earth possesses resistance, forcing current to flow through it results in a power loss—the power being supplied by the transmitted wave. As the frequency of the signal increases, the amount of power that is lost rises until, at about 2 mc, the coverage obtained by means of the surface wave is limited to very short distances. At this point it loses its communications value.

The other divisions of the ground wave, the direct wave and the earth reflected wave, do not become important until the signal frequencies rise above 30 mc. Long-distance communication between 2 mc and 30 mc is accomplished principally by the sky wave.

### Sky-Wave Ionosphere

Radiated energy which does not follow the contour of the earth travels upward through the air until it reaches a region called the ionosphere, a concentration of ions and electrons. If the frequency of the radio waves is below 40 mc (approximately), the ionosphere



PF REPORTER • February, 1958



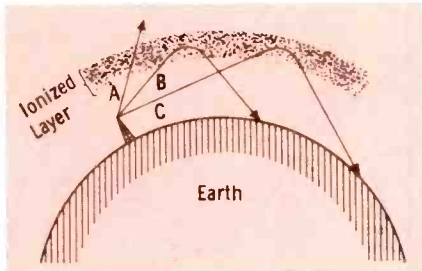

Fig. 2. As the frequency of a signal increases, ionospheric effect decreases.

will cause the waves to bend back toward the earth. Above 40 mc, the bending of the wave in the ionosphere is generally so small that the wave passes through this region and on into outer space until its energy diminishes completely. This is illustrated in Fig. 2, where wave A possesses a frequency above 40 mc and waves B and C are below 40 mc.

#### High-Frequency Propagation

Since television uses the frequencies above 40 megacycles, the only practical method of communicating over an appreciable distance is by the direct wave, also known as line-of-sight transmission. In this method, the transmitting antenna is mounted as high as possible and the signal energy it sends out travels on a straight line directly to the receiving antenna. If the receiving antenna is too far away, the signal will never reach it, as shown in Fig. 3. The energy from the transmitting towers will travel out to the horizon and then will continue to travel on a straight line out into space; the ionosphere will not bend these waves back to earth. Obviously, the higher the transmitting antenna, the greater will be the area it covers. By the same reasoning, the higher the receiving antenna, the better chance it will have of intercepting the signal waves.

The line-of-sight distance to the horizon may be derived as follows: In Fig. 4, the height of the transmitting antenna is called  $h_t$ , the

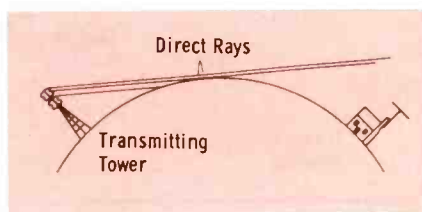

Fig. 3. Reception of direct rays becomes impossible beyond a certain distance.

February, 1958 · PF REPORTER

## CORNELL-DUBILIER CAPACITORS



### The extra values are "on the house"

Want more capacitor for your dollar? Here's how:

Cornell-Dubilier has originated a "preferred-type" program on twist-prong electrolytics. Now, a relatively few types fill over 90% of all replacement requirements. You need less — to do more. Fewer types means improved production efficiency, lowered costs — savings to you. How is it done? Instead of producing hundreds of types with odd and critical capacitance and voltage ratings, each "preferred type" carries the highest value and rating called for in each category. In most cases you get more capacitor at lower cost — plus added safety factor, improved performance and "call-back" protection. It's on the house! To get more capacitor for your dollar, ask your C-D Distributor about Preferred Type Twist-Prong Electrolytics or write Cornell-Dubilier Electric Corporation, South Plainfield, New Jersey.



## CORNELL-DUBILIER CAPACITORS

Consistently Dependable

# CDR ROTORS

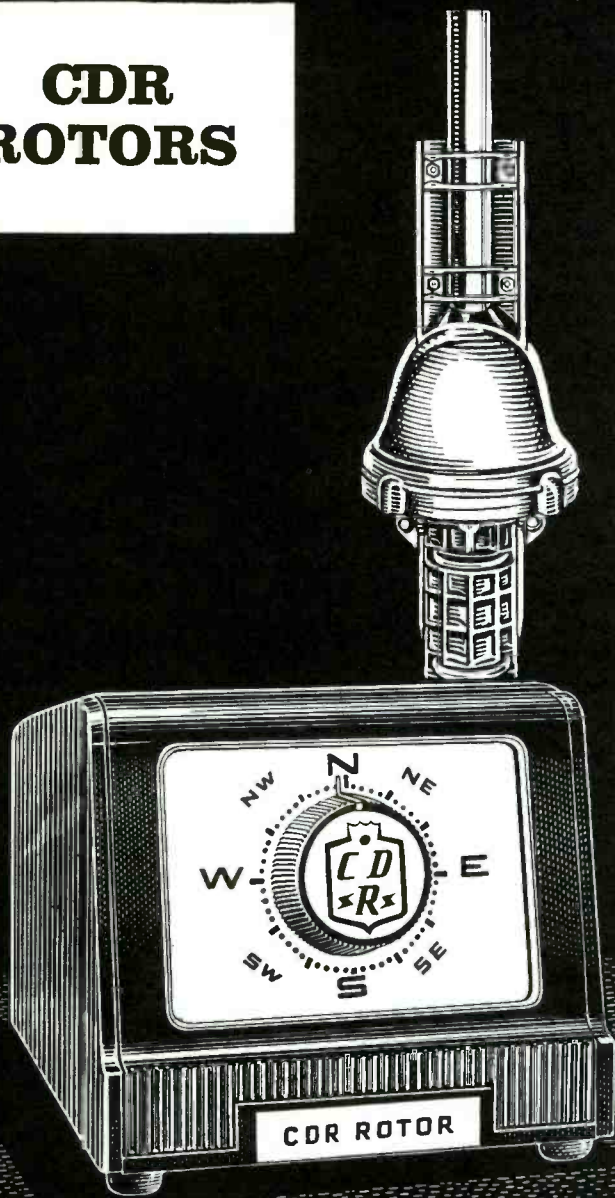

## All-weather dependability

CDR rotors are noted for their ability to perform consistently and dependably under all weather conditions . . . no "freezing" of gears, no "drift" in heavy winds, no drop-off in accuracy over the years. That's why CDR rotors are virtually service-free . . . why they are the choice of Radio Hams.

Fact is, if it's an antenna, a CDR rotor will turn it. And there's a CDR rotor for every job—from simple dipoles to stacked arrays.

CORNELL-DUBILIER ELECTRIC CORP.  
South Plainfield, New Jersey

THE RADIART CORPORATION  
Indianapolis, Indiana



# CDR Antenna Rotors

Old Hands at Dependability

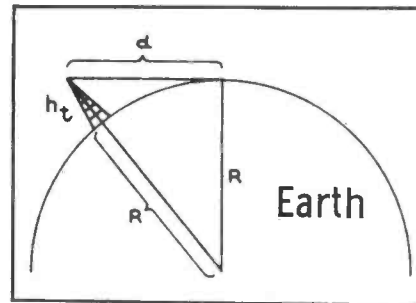

Fig. 4. Diagram from which the line-of-sight distance is computed.

radius of the earth is  $R$ , and the distance from the top of the antenna to the horizon is  $d$ . With these designations, the figure formed becomes a right triangle, and we may write the following relationship:

$$R^2 + d^2 = (R + h_t)^2. \quad (1)^*$$

Squaring the second term, (1) becomes

$$R^2 + d^2 = R^2 + 2Rh_t + h_t^2. \quad (2)$$

Since  $h_t$  is very small in comparison to  $R$  (radius of the earth), little error is introduced if we disregard  $h_t^2$ . Doing this, (2) becomes

$$R^2 + d^2 = R^2 + 2Rh_t. \quad (3)$$

Transposing  $R^2$  and cancelling, (3) becomes

$$d^2 = 2Rh_t. \quad (4)$$

Taking the square root of both sides, (4) becomes

$$d = \sqrt{2Rh_t}. \quad (5)$$

The earth's radius ( $R$ ) is 4,000 miles. Because  $h_t$  is in feet, however, a factor of 5,280 must be introduced. Dividing this into 8,000, (5) becomes

$$d = \sqrt{1.51 h_t} \quad (6)$$

which is

$$d = 1.23 \sqrt{h_t} \quad (7)$$

where  $d$  is in miles, and  $h_t$  is in feet.

\* For any right triangle, the square of the hypotenuse is equal to the sum of the squares of the other two sides.

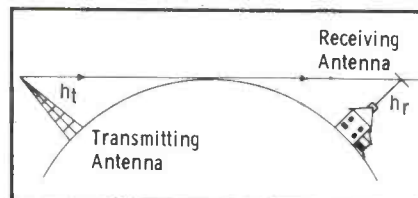

Fig. 5. Distance between antennas is the sum of the two distances to the horizon.

Equation (7) does not consider the height of the receiving antenna. Fig. 5 illustrates that the maximum line-of-sight distance is the total of the line-of-sight distance of each antenna. Thus, the maximum distance that a receiver can be removed from the transmitter and still intercept the signal from the transmitter becomes

$$d = 1.23 (\sqrt{h_t} + \sqrt{h_r}) \quad (8)$$

where

$d$  = distance in miles,

$h_t$  = height of transmitter antenna in feet,

$h_r$  = height of receiving antenna in feet.

There is still another modification that must be made to the foregoing formulas due to the fact that signals frequently can be received beyond the limits indicated above. This arises from two actions—refraction in the lower atmosphere regions and diffraction by the surface of the earth at the horizon. To take into consideration the distance increase produced by these two effects, the factor of 1.23 above is raised to 1.41. Thus equations (7) and (8) become

$$d = 1.41 \sqrt{h_t} \quad \text{and}$$

$$d = 1.41 (\sqrt{h_t} + \sqrt{h_r}).$$

Because raising the antenna height increases the direct-line distance, transmitting antennas for FM and television stations are placed at the highest available site. There may be, however, other obstacles in the path of the direct waves which would result in absorption of the signal energy and hence tend to weaken or distort the received sound or picture.

Quite frequently, when a receiving antenna is being installed, it will be found that the signal pickup does not increase smoothly with antenna height, but rather, that the signal strength will increase for a while and then actually decrease as the antenna is raised still higher. Then, as you continue to go higher, the signal pickup will again rise, usually to a level slightly above that reached during the preceding increase. If the process of raising the antenna is continued, and the signal pickup noted, it will be found that the signal goes through a series of alternate increases and decreases, gradually climbing toward an ul-

February, 1958 • PF REPORTER

## TOBE SERVICE CAPACITORS

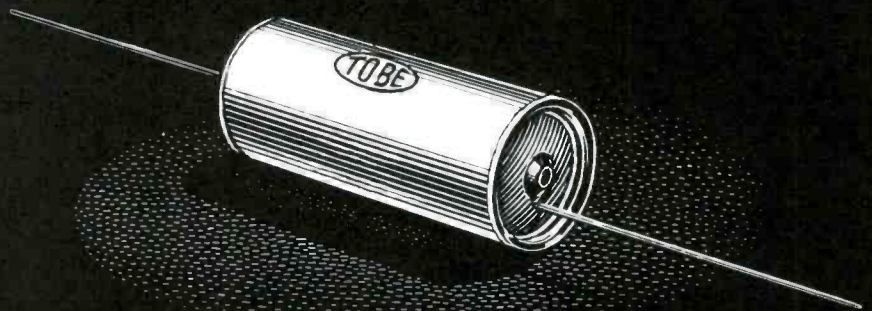

### Designed exclusively for service

Tobe Service Capacitors are the only capacitors literally "designed from the ground up" to meet the exacting requirements of modern radio and TV servicing. Before a capacitor was ever produced, Tobe engineers determined the ideal characteristics—then borrowed from their 36 years experience in the design and manufacture of high-quality commercial and industrial types. Result: capacitors like the plastic-sleeved streamlined "Jets" that stand up in the toughest circuits.

You owe it to yourself to try Tobe Service Capacitors on your next job. The line is complete—and they cost no more! See your Tobe Distributor today for full details or write Tobe Deutschmann Corporation Distributor Division, 2900 Columbia Ave., Indianapolis 5, Ind.



**TOBE**  
RADIART  
CAPACITORS

*Old Hands at Dependability*

timate maximum. However, the higher you go, the less pronounced the variations become, and eventually, after several hundred feet, they disappear altogether and the signal rises rather smoothly.

This behavior stems from the fact that the signal developed at the receiving antenna is due not only to the direct wave but also to a ground reflected wave. In Fig. 6, the waves reaching the antenna may do so by one of two paths—by going directly to the receiving antenna, or by arriving there after

reflection from the earth's surface. The strength of the resultant depends upon the phase relationship between the two signals. To illustrate this point further, note what happens to the reflected wave. At the point where the reflected wave strikes the earth, a phase reversal of  $180^\circ$  takes place. In addition, energy is absorbed in an amount dependent on the conductivity of the earth. The phase shift causes the reflected wave to oppose the direct wave, lowering its signal level. Fortunately, two conditions

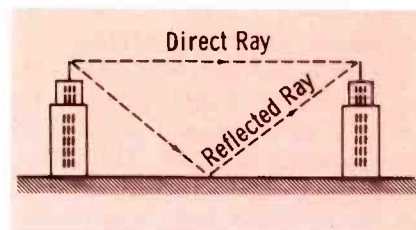

Fig. 6. How ground-reflected rays reach the receiving antenna.

act against this decrease. One is a weakening of the reflected wave due to absorption at the point where it contacts the earth; the other stems from an additional phase difference brought on because the path of the reflected wave is longer than that of the direct wave. Thus, there is a total phase shift of  $180^\circ$  plus whatever other change takes place because of the longer path. As a result of these factors, the strength of the direct signal is not decreased as much by the reflected wave as one would at first expect.

With added antenna height, a decrease in noise pickup occurs. For FM and television signals, this decrease is most important. By raising both antennas, we can increase the difference between the direct and earth-reflected wave paths and thus narrow the difference in their phases. When a phase difference of  $360^\circ$  occurs between the signals, they will be in phase and add, producing a field strength which approaches twice that obtainable from the direct wave alone (depending, again, on the amount of unabsorbed energy that arrives via the reflected path). In general, the higher the antenna, the stronger the received signal will be.

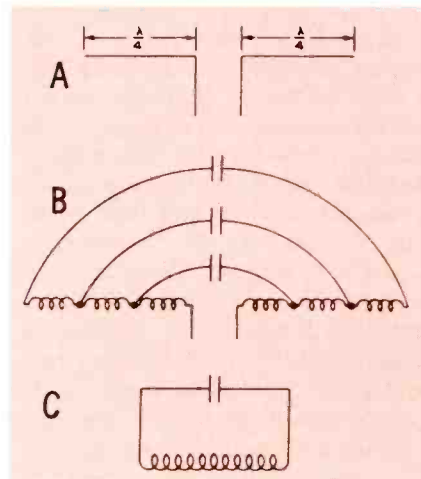
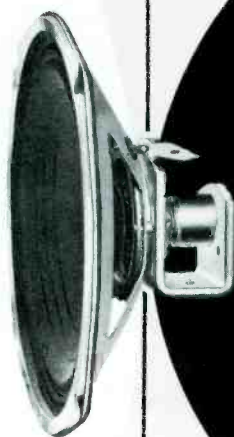

Fig. 7. A half-wave dipole has distributed inductance and capacitance and is the equivalent of an LC circuit.

## COMPARE THE WEIGHT of a



# QUAM

*Adjust-a-Cone*<sup>®</sup>

# SPEAKER

**QUAM-NICHOLS  
COMPANY**

234 EAST MARQUETTE ROAD  
CHICAGO 37, ILLINOIS

You'll find that Quam speakers are heavier than other speakers of equivalent size and magnet weight—because they are built of stronger, finer quality materials.

Quam speakers have heavier gauge metal baskets . . . larger and more efficient magnetic structures . . . more insulating and impregnating materials.

The result is a more rugged, longer lasting speaker that is sure to be in perfect operating condition when you take it out of its factory package. Quam speakers are always shipped in individual protective cartons . . . never in bulk!

*ask for QUAM, the quality line for all your speaker needs*

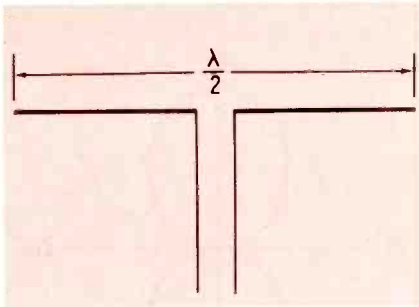

Fig. 8. A length of wire one-half wave long is the shortest that can be made to act as a resonant circuit.

This combination of direct and earth-reflected waves is sometimes referred to in literature as a space wave.

### Dipoles

With the foregoing discussion as a background, let us turn our attention back to the antenna itself. Antennas are resonant circuits, and they build up the maximum amount of signal voltage when they possess the proper length (see Fig. 7). Every conductor contains resistance, inductance, and capacitance. The length of the conductor constitutes the inductance; the capacitance is formed along the various sections of the conductor. Hence, by cutting the antenna's conductors to the proper length, we can make them resonant to whatever frequency we choose.

The smallest length of wire that can be made to act as a resonant circuit is an ungrounded antenna cut to one-half the wavelength of the signal to be received (see Fig. 8). To compute the proper length for the half-wave antenna, we use the following equation:

$$\text{Length in feet} = \frac{468}{\text{Frequency (mc.)}}$$

This equation is derived from the relationship that a wavelength is equal to the velocity of the wave divided by its frequency,

$$\lambda = \frac{V}{f} \quad (9)$$

where

$\lambda$  = the wavelength in feet,

$V$  = the velocity in feet per second and

$f$  = the frequency of the wave in cycles per second.

The velocity of the wave is the same as the velocity of light, or approximately 984,000,000 feet per second. Substituting in (9) we have

$$\lambda = \frac{984,000,000}{\text{Freq. (cycles)}} \text{ feet.} \quad (10)$$

Since the frequency for television stations will always be given in megacycles, equation (10) becomes

$$\lambda = \frac{984}{\text{Freq. (mc.)}} \quad (11)$$

We wish to find the length of a half-wave antenna, so we take half (11) and obtain

$$\text{Length (feet)} = \frac{492}{\text{Freq. (mc.)}} \quad (12)$$

Because the velocity of an electromagnetic wave on a wire is slightly lower than the same wave in free space, a correction factor of .95 is necessary in equation (12). Multiplying 492 by .95 gives

$$\text{Length (feet)} = \frac{468}{\text{Freq. (mc.)}}$$

There are two quarter-wave sections to a half-wave dipole. Hence, dividing by 2, each section will be

$$\text{Length (feet)} = \frac{234}{\text{Freq. (mc.)}} \quad (13)$$

it's TWINS at JSC!

**NEW 20 Strand** 100 Mil and 80 Mil Thickness  
**400 Mil Wide**

the **ROYALTY** line

A JSC "beat" on the wire market . . . proved superior to all other wires, yet lower in price! JSC does it again with a top quality wire available in your choice of 100 mil and 80 mil thickness . . . the finest for installers who demand the finest!

AVAILABLE IN 100 MIL AND 80 MIL THICKNESS

- Over 400 mil wide
- 20 strands full gauge copper
- Made with pure polyethylene for low db loss

**NEW 10 Strand** 100 Mil and 80 Mil Thickness  
**385 Mil Wide**

the **BANNER** line

Want the "best for less"? Find it in JSC's sensational new BANNER line — 385 mil standard width — 10 strand wire — all the finest quality features at far less than you ordinarily pay!

AVAILABLE IN 100 MIL AND 80 MIL THICKNESS

- 10 strands full gauge copper
- JSC regular wide 385 mil width
- Made with pure polyethylene for low db loss



You Can Depend On ALL JSC Wire . . .

- more flexibility for easier handling
- full width for perfect impedance
- made from pure polyethylene for low db loss
- marked every foot

**ONLY JSC GIVES YOU GOLD, SILVER, CLEAR AND BROWN WIRE AT NO EXTRA COST!**

Buy It By The 1000 Ft. Spool Or On Handy 50 - 75 - 100 Ft. Coils In Attractive Colorful Display Carton Or On Display Stand.

JSC Wire Sold By Wholesale Distributors . . . Everywhere!



**JERSEY SPECIALTY CO., INC.**  
Burgess Place Mountain View, Wayne, N. J.  
NEW PHONE: Clifford 6-3700



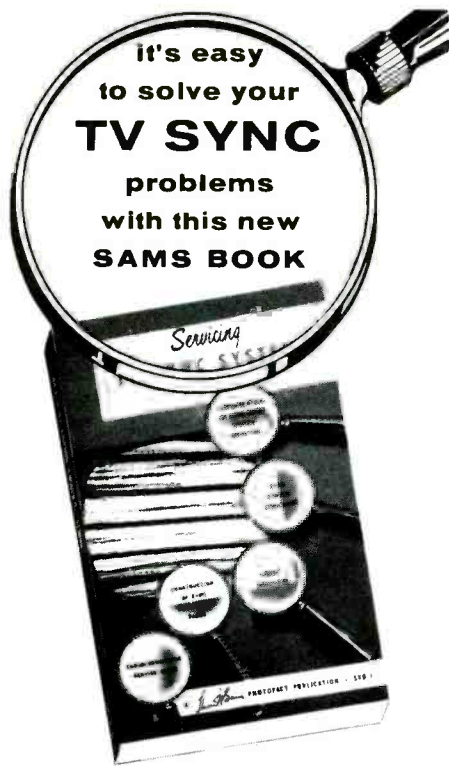

## "Servicing TV Sync Systems"

by Jesse Dines

Valuable time-saving book for Service Technicians. Covers fully the theory of operation, circuit function and circuit variations of the 18 different types of sync systems used in TV receivers. Explains various types of sync separator, horizontal and vertical oscillator, and horizontal AFC circuits used in sync systems. Methods of analyzing and troubleshooting these circuits are supported by actual picture tube photos and waveforms illustrating types of sync troubles. Includes valuable data on oscillator coils, transformers and printed electronic circuits used in sync systems. Has chapter on practical servicing hints. This book will definitely help the technician to better understand and more easily service any type of sync system trouble. Written clearly and simply for quick and easy understanding. 320 pages; 221 illustrations, 5½ x 8½".

PRICE ONLY **\$3.95**

SEE THIS MONEY-EARNING BOOK AT YOUR ELECTRONIC PARTS DISTRIBUTOR OR MAIL COUPON TO HOWARD W. SAMS...



### FREE TRIAL COUPON

Howard W. Sams & Co., Inc., Dept. 3-B8  
2201 E. 46th Street  
Indianapolis 5, Indiana

Send me Jesse Dines' book "Servicing TV Sync Systems" for 10 days FREE examination. In 10 days I will pay for the book, plus small delivery cost, or return postpaid.

We pay delivery costs if you remit with this coupon. Same return privilege.

Name.....

Address.....

City..... Zone..... State.....  
(outside U.S.A. priced slightly higher)

### Dipole Response Curve

Probably the most important characteristic of an antenna, aside from its resonant frequency, is its response curve. From what direction or directions will it best receive signals? For a dipole, the signals are received with greatest intensity when the rods are broadside to the direction of the signal as illustrated in Fig. 9. Signals approaching the antenna from either end, however, are very poorly received. In between, the strength of the received signal varies. Because good signal strength is obtained from two directions, the dipole response may be called bidirectional. Later, we will see how this characteristic can be modified so that reception is achieved from only one direction, i.e., a unidirectional response. For many installations, the latter is preferable.

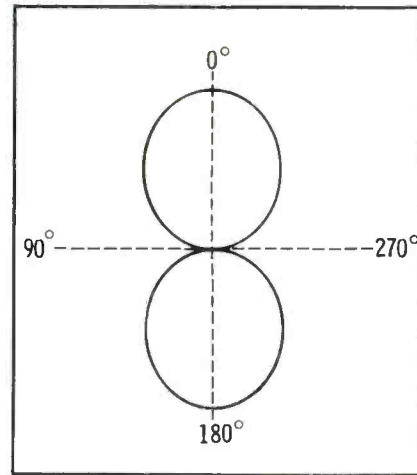

Fig. 9. Bidirectional response pattern of a simple dipole antenna.

### Impedance Matching

After a signal is developed in the antenna, it is necessary to provide some way for it to reach the receiver. For this purpose, a transmission line is used. Because the impedance of a dipole is on the order of 72 ohms, the maximum transfer of energy from the antenna to the line occurs only when the line impedance is 72 ohms. Such lines, either flat twin lead or coaxial cable, are available. But the input impedance of most television receivers is 300 ohms and the 300-ohm twin-lead is more common. What happens if this is used instead? The answer, of course, is that less power will be transferred to the line and less signal will reach the set. In moderate or strong signal areas, the loss would not be noticed particularly; in weak signal areas, its effect would definitely be visible in a weaker picture accompanied by more snow.

Mismatching at the antenna results only in loss of power, but if the mismatching occurs at the receiver, it can produce ghost images which will blur the picture. This occurs because not all of the signal traveling down the transmission line from the antenna can be absorbed by the receiver input circuit. Due to the mismatch, some of it is reflected back along the line to the antenna and then back

down to the set again. Since it takes this signal some small but definite time to travel, it is actually lagging the original signal when it reaches the receiver input for the second time. On the television screen this time lag causes the reflected signal to appear slightly to the right of the original signal since beam scan is controlled by the original (and stronger) signal which has a slight phase lead over the reflected signal.

If the set is located in a strong signal area, there may be 3, 4, or even more reflections on the transmission line as the signal bounces back and forth. This can cause 2, 3, 4, or more ghosts, which will seriously distort the picture.

The foregoing behavior is due to a mismatch between the transmission line and the receiver. A mismatch between the line and the antenna will cause only a loss of power, because any waves traveling away from the antenna (on the transmission line) will be absorbed at the receiver if an impedance match exists there. Since there will be no waves traveling back and forth along the transmission line under these conditions, no ghost images will be produced. The moral of all this is: If you must have mismatching in strong signal areas, do it at the antenna rather than at the receiver; in weak signal areas, do it at the receiver.

Next month, we'll get into antenna designs, discussing the basic principles and the effects of reflectors and directors on gain and directivity. ▲

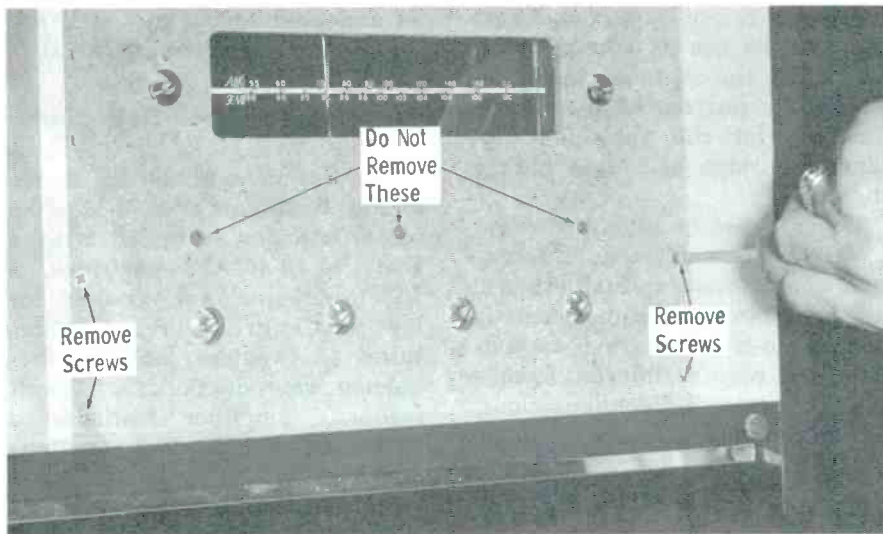

Fig. 8. Escutcheon removed in preparation to tuner and control unit removal.

capacitor and DC blocker C1, and the DC return for the grid of the 2nd stage R4. Actually, C1 does affect the low frequency response since its impedance will be fairly high at low audio frequencies, but this is not the reason it is used. As a matter of fact, its effect is the opposite of that we are trying to obtain and must be considered as a factor in the design of the compensating network.

Getting into the network itself, we find that C2 and R2 form a low-pass filter network which functions to attenuate the highs more than the lows. This happens because the higher the frequency

the lower the value of  $X_c$  for any given capacitor. In the vernacular of the hi-fi fan, C2 provides high frequency roll-off.

Now we get to the series network of R3 and C3, and again we have a reactance ( $X_c$ ) that varies with frequency. If you calculate the reactance of a .02 capacitor, you will find that: at 60 cps  $X_c$  equals 191K; at 1,000 cps  $X_c$  equals 7,950 ohms; at 10,000 cps  $X_c$  equals 795 ohms; and at 20,000 cps  $X_c$  equals 397 ohms. Since  $X_c$  and R are in series, we find that the net result is an impedance which varies from 12,397 ohms at 20 kc to 203,000 ohms at 60 cps.

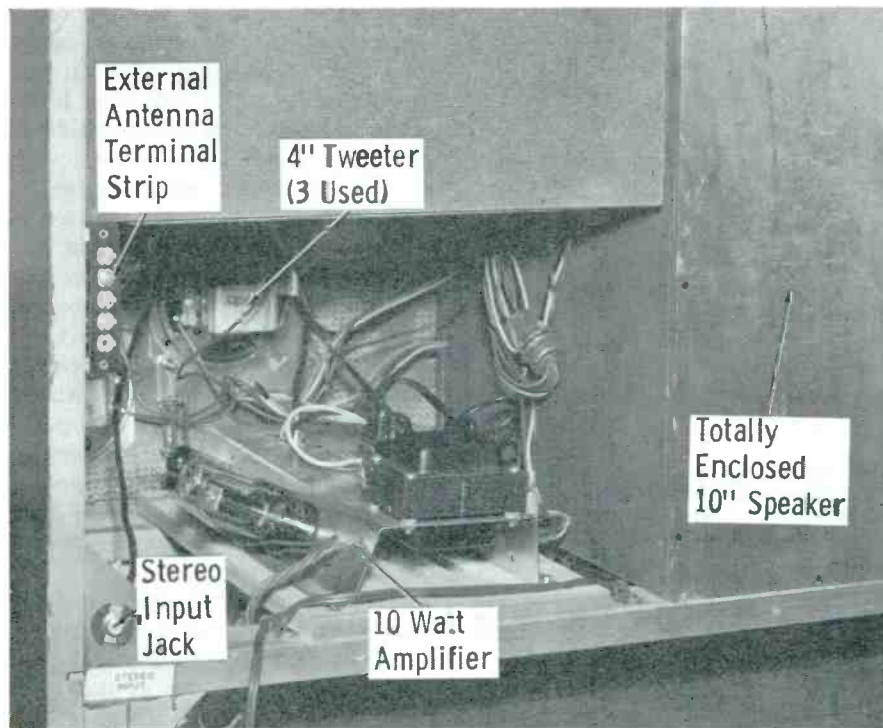

Fig. 9. Rear view showing amplifier mounting, stereo jack and speaker enclosure.

**NEW! IMPROVED!**  
**SENCORE**  
 TRC4  
**TRANSISTOR CHECKER**

*Another Sencore Time-Saver*

America's newest, most popular test instruments

**NOW CHECKS:**

- ★ **Transistors** for opens, shorts, leakage and current gain. Includes new gain test on power transistors.
- ★ **Crystal Diodes** checks forward to reverse current ratio on all diodes.
- ★ **Selenium Rectifiers** checks forward and reverse currents.

Controls are accurately set for each transistor by referring to replaceable set-up chart on rear. Test leads or socket provides for fast hook-up. See your parts distributor.

**ONLY \$17.95**  
 Dealer Net  
 Cannot become obsolete. Approved by leading manufacturers

Simple to Operate

Mfg. by **SERVICE INSTRUMENTS CORP.**  
 171 OFFICIAL RD., ADDISON, ILL.

Cut out this ad now for further information

**SERVICEMEN WHO CARE . . . USE**

the *Dynamic*  
**NEW and AMAZING**

**FILTER TENNA**

with the **EXCLUSIVE** built-in **HI-PASS FILTER**  
 T. M. Reg. Pat. Pend.

**THE FIRST TRULY ELECTRONIC INDOOR TV ANTENNA TO GIVE CLEAR FILTERED RECEPTION.**

**\$18.95 List in 3 SATIN FINISHES**  
 • COPPER • CHROME • BRASS

**UNMISTAKABLY THE FINEST INDOOR TV ANTENNA!**

Manufactured by  
**DYNAMIC ELECTRONICS-NEW YORK, INC.**  
 Forest Mills, Long Island, N. Y.

If we further analyze this circuit, we see that any signal appearing at the junction of C1, C2 and R2 will divide between R2 and the combination of R3 and C3. Since the total impedance of R3 and C3 is higher at low frequencies, more signal voltage will be applied to the output grid at low frequencies. This is the type of equalization circuitry employed for a common variable-reluctance style of pickup cartridge.

Equalization may not always be accomplished entirely between the halves of a dual triode as shown

in Fig. 4. In many cases, high frequency roll-off is accomplished through the use of a small resistor across the input as shown in Fig. 5. Its purpose is to provide damping for the variable-reluctance cartridge and thus reduce the highs.

Other types of pickup devices usually require different equalization characteristics; furthermore, different circuit designs such as pentode-to-triode or triode-to-pentode) will require different equalization network configurations. However, these circuits could be

analyzed in the same manner for an understanding of how they are used to accomplish equalization.

### Servicing Packaged Hi-Fi Units

The Columbia Model 583 shown in Fig. 6 consists of a V-M 1200-series changer equipped with a Ronette 10-400-OV cartridge, a 10" totally-enclosed speaker for low and midrange reproduction, three 4" tweeters for high frequency reproduction, a 10-watt feedback amplifier featuring a choice of equalization (switch) plus bass and treble controls, and an AM-FM tuner which has FM sensitivity of  $3\mu\text{v}$  for 20 db of quieting and AM-loop sensitivity of  $80\mu\text{v}$  meter.

So much for what's in the box—now let's get right into servicing the unit. First of all, there are the tone-arm setdown and tracking force adjustments. As shown in Fig. 7, setdown adjustment is made by turning a screw on the tone-arm base and tracking force (original tracking force when the unit was unpacked was 6 grams) is adjusted by moving the counterbalance spring one way or the other along the row of notches on the underside of the tone arm.

The turntable may be removed from above to permit replacement of the drive and idler wheels by removing the spring clip at the base of the spindle. If it becomes necessary to remove the entire changer, the spring clips in the lower end of the shipping hold-down screws (one on each side of changer base) must be removed.

The function selector switch on the tuner must be placed in the "stereo" position to disable the tuner during phono or stereo operation. A master on-off switch is ganged with the loudness (volume) control. The equalization switch must be set to the "tuner-stereo" position for tuner operation in order to get AC power to the tuner. It must be set to one of the three phono positions for phono operation to get AC power to the changer motor.

Getting into the tuner unit for servicing is somewhat of a chore. It is necessary to remove all knobs and both escutcheons as shown in Fig. 8, and then the four screws indicated. After unplugging the

## You get these *plus* features with STANCOR

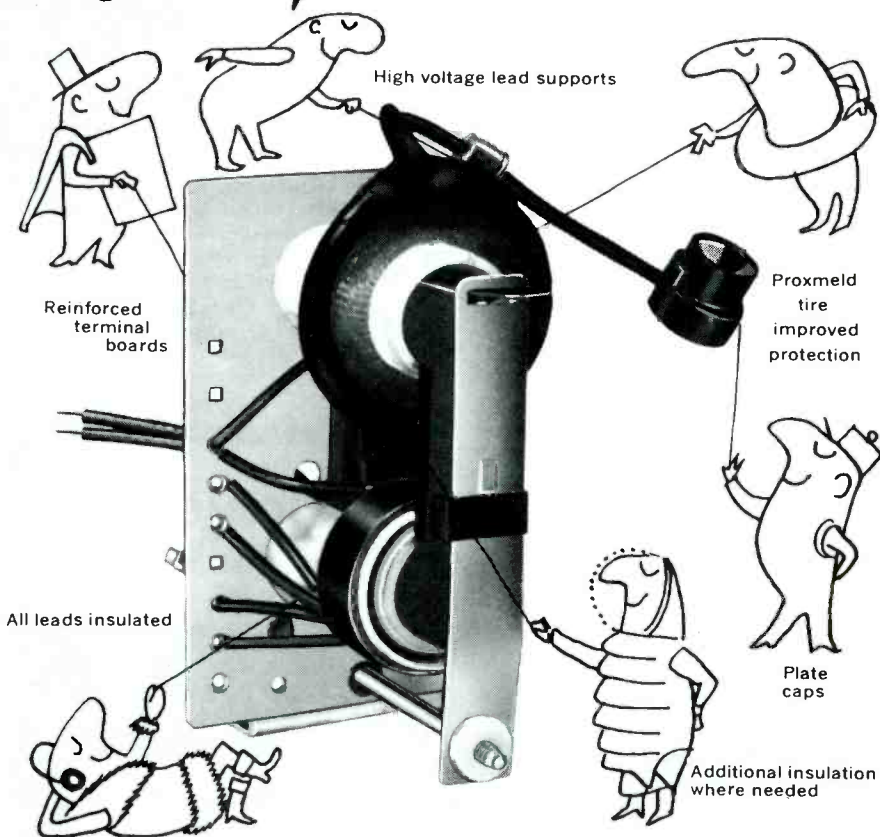

Stancor, the pioneer in the field of exact replacement flybacks, now goes one step further. The Stancor replacement represents an *improvement* over the original manufacturer's units. Additional features—like those above—are added when necessary to insure optimum performance. Stancor flybacks are engineered and improved replacements to help make your work more efficient and more reliable.

**FREE** —a new 100 page TV Replacement Guide with a brand-new format. Locates the replacement immediately—with or without the original part number. Models listed individually in numerical order. See your distributor or write us for your free copy.

### CHICAGO STANDARD TRANSFORMER CORPORATION

3503 Addison Street • Chicago 18, Illinois

Export Sales: Roburn Agencies, Inc. • 431 Greenwich Street • New York 13, N. Y.





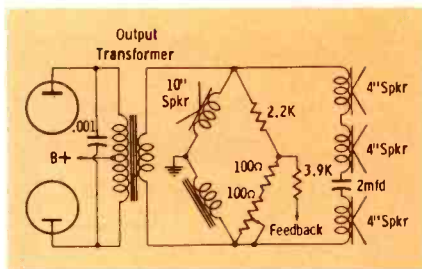

Fig. 10. D. E. P. Network.

tuner from the amplifier and changer, the entire tuner and control assembly may be removed from the cabinet. The tuner tubes can then be checked after the metal cover has been removed. A good tube tester will come in mighty handy here.

Now that we have examined the topside of this package, let's see what we can find below. The 10-watt amplifier mounts on a board (Fig. 9) near the bottom of the cabinet to the rear of the three 4" tweeters. The box you see to the right (below the changer) is a total enclosure for the 10" speaker and is mounted slightly to the rear of the front panel of the cabinet.

Anytime you have trouble with this unit circuitwise, be sure to take the entire package into the shop. This is necessary because a fancy combination feedback and speaker-matching network is employed, and among the components in this network are the inductor mounted with the 10" speaker and the capacitor between two of the tweeters. A schematic of this network, which Columbia calls Directed Electromotive Power or D.E.P., is shown in Fig. 10. This circuit has been factory-adjusted, and unless a speaker has been changed, it should not require readjustment.

When a speaker has been replaced, however, it is necessary to rebalance the system to compensate for the individual speaker characteristics and optimize feedback for the most stable operation. The D.E.P. network is balanced in the following manner: 1. Remove the 4-pin speaker plug. 2. With the male plug facing you wide space down and reading clockwise, the pin farthest to the right is 1. Connect a microammeter to pins 3 and 4 in series with a resistor  $\frac{1}{20}$ th the internal resistance of the meter (positive to 3). 3. Adjust the D.E.P. control for a zero reading on the meter. Cau-

tion! Use high (milliamp) range for a test reading and then gradually work down to a low microamp range. Never attempt to adjust the D.E.P. control while playing either a record or the AM-FM tuner.

The tuner uses a printed wiring board for the entire chassis, and the manufacturer states that a soldering iron of 35 watts or less and 60/40 solder (60% tin—40% lead) should be used.

A jack is provided so that the Model 583 can be used as one leg of a stereo system. With the equal-

izer switch in the stereo position and the tuner turned off (Stereo position on Function switch), the input from the jack on the rear of the cabinet (Fig. 9) is applied to the amplifier.

Should it become necessary to remove the amplifier chassis, be sure to disconnect the pilot-lamp bracket from the 4" speaker-mounting bolt; also disconnect the necessary interconnecting cables. A handful of assorted extension cables would be most desirable when servicing this unit in the home.

**ALL OVER THE U.S.**  
*utah* STANDS for  
**UNSURPASSED SERVICE**

Yes . . .

**ALL OVER THE U.S.**  
**UTAH STANDS for UNSURPASSED SERVICE**

Yes, all over the U. S.—Utah stands for Unsurpassed Service.

US—Utah and the Service Man—because Utah stands behind you—the Service Man.

Utah stands behind you—with a speaker name that for over 30 years has signified the finest in quality, design, engineering and production.

Utah stands behind you with a speaker that gives installation performance. You can sell customer satisfaction with a Utah—because Utah gives performance satisfaction.

Utah stands behind you—with a secure source of supply. Leading jobbers all over the U. S. handle Utah—because Utah has the finest and widest line of replacement speakers available to the trade.

Utah your one complete speaker source auto \* Rear Deck Kits \* Standard Replacement \* Television \* Public Address \* High Fidelity \* Outdoor \* Inter-Com \* Wood & Metal Baffles

Utah is your one, complete satisfactory speaker source. When you order speakers today — **THINK**—then order Utah.

Get your **FREE** copy of the latest Utah Catalog S-157 listing over 100 replacement speakers. Available at your distributors or write direct.

**RADIO PRODUCTS CORPORATION**  
HUNTINGTON • INDIANA

Export Dept. Fidevox International, Chicago, Illinois

**EICO** 84 Withers St., Brooklyn 11, N. Y. PF-2

**SAVE ME 50%** on precision instruments —  
send **FREE CATALOG** on EICO's 46 models  
in factory-wired and kit form.

My Name .....  
Address .....  
City ..... Zone ..... State .....

**NEW! COLOR**  
and Black-&White  
DC to 5 MC LAB & TV  
5" OSCILLOSCOPE

#460  
Factory-wired  
and tested ..... \$129<sup>50</sup>  
Also available as kit ..... \$79<sup>95</sup>

• Features DC Amplifiers!

Flat from DC-4.5 mc, usable to 10 mc. **VERT. AMPL.:** sens. 25 rms mv/in; Z 3 megs; direct-coupled & push-pull **throughout**; K-follower coupling bet. stages; 4-step freq-compensated attenuator up to 1000:1. **SWEEP:** perfectly linear 10 cps-100 kc (ext. cap. for range to 1 cps); pre-set TV V & H positions (30 & 7875 cps); auto. sync. ampl. & lim. **PLUS:** direct or cap. coupling; bal. or unbal. inputs; edge-lit engraved lucite graph screen; dimmer; filter; bezel fits std photo equipt. High intensity trace CRT. 0.06 usec rise time. Push-pull hor. ampl., flat to 400 kc, sens. 0.6 rms mv/in. Built-in volt. calib. Z-axis mod. Sawtooth & 60 cps outputs. Astig. control. Retrace blanking. Phasing control.

**BEFORE** you buy ANY instruments—get the **FACTS** on the money-saving, high-precision EICO line. Fill in coupon for **FREE** catalog & name of your nearby distributor.

**EICO** 84 Withers St., Brooklyn 11, N. Y.  
Prices 5% higher on West Coast



Fig. 11. "Tape-It-Off-The-Air" kit.

**Products for Profit**

**Tape Sales**

ORRadio Industries' promotion, "Tape-It-Off-The-Air," is aimed at helping the dealer who stocks recording tape expand his business. The company claims that the largest users of recording tape are music lovers and hobbyists who record such things as operas, FM broadcasts, TV spectaculars, etc.

To help dealers expand in this field, ORRadio has prepared a special kit (Fig. 11), which consists of a two-color easel display card with pockets containing detailed instructions on how to record programs off the air, a two-color window streamer to identify the store as a "Tape-It-Off-The-Air" headquarters, and promotion literature showing how the dealer can increase his own tape and recorder business.

Tape recorders have been increasing in popularity so that tape sales to walk-in customers and even to customers on home service calls represents a potential for greatly increasing the enterprising dealer's income. When making home calls, casually mentioning that you stock recording tape may prove to be just the "in" you need with the hi-fi or recording fan. The instruction folder should be the final sales clincher.

**Phono and Hi-Fi Connecting Cables**

Walsco Electronics Mfg. Co. is producing a line of shielded phono cables that feature molded-on

**COLMAN Electronic Products**

**CLOCK-RADIO KNOBS**

The most complete line of replacement clock-knobs in the U. S. Numerous types in 10 different colors.

**TV REPLACEMENT KNOBS**

Replacement TV knob sets for many popular sets. Front and side tuning models. Mahogany or blonde.

In stock at leading parts jobbers everywhere.

**COLMAN TOOL & MACHINE CO.**  
P. O. Box 7026—Amarillo, Texas  
Canadian Representative: Wm. Cohen Ltd., 7000 Park Ave., Montreal, Canada

**SUBSTITUTE PARTS WITH-OUT SOLDERING**

Quickly with E-Z-Hook "SUB" Connectors

Has 1001 Uses!

Connect a speaker, or substitute a transformer, capacitor, resistor, or choke. In Seconds!!

★ Makes connections instantly!  
★ Won't pull off!  
★ Insures positive contact!

Saves time, money and parts in servicing, experimenting, instructing and production.

**E-Z-HOOK SUB**  
No. 71-1...SUB... Only 69¢ ea.  
Six Colors! - for Easy Lead-Identification

**E-Z-HOOK TEST PRODUCTS**  
ORDER THROUGH YOUR PARTS DISTRIBUTOR  
E-Z-HOOK TEST PRODUCTS  
Dept. F, 1536 Woodburn Ave.  
Covington, Ky.



"Why, Rudolph!  
You're almost human  
since we bought the  
**JENSEN NEEDLE**".

"Tenite" connectors. These cables, samples of which are shown in Fig. 12, are available in lengths from 10" to 72" and with all possible connector combinations of phono-pin plugs and jacks, alligator clamps, spade lugs and phone jacks. The combination of phono-pin plug on one end and alligator clamps on the other should prove most useful in the shop for testing purposes.

Also available are several cable adapters—female microphone to phone plug, microphone connector to phono-pin plug, a connector to join two cables equipped with male connectors, and phono-pin plug to standard phone plug, to name a few.

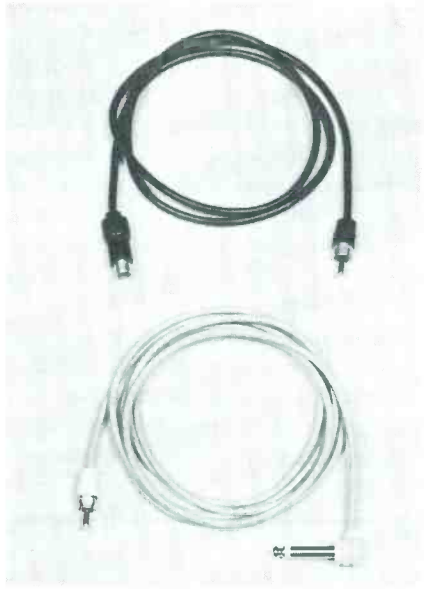

Fig. 12. Walsco phono cables.

**ABOUT THE COVER**

Isn't it fantastic (and pleasing) the way the minds of the modern young male generation can be swayed by the miracles of electronics? At least, this seems to be the case with our teen-age model who is so engrossed in the workings of a TV set that he's even forgotten his date. Let this serve as a reminder not to get so wrapped up in your work that you forget your sweetheart this February 14th.

**note:**  
*Estimated 1 3/4 million portable TV sets to be sold in '57!*

**Here's Your MARKET...**

(Advertisement)

MODEL 648		MODEL 115/715/561	
TUBE TYPE	FIL. D.	FIL. X.	PLATE YZ
3DK6	3.0 AC1234	567* 16WY	26 3JKKMQ
4DK6	4.2 AC1234	567* 16WY	26 3JKKMQ
6DK6	6.3 AC1234	567* 16WY	26 3JKKMQ
12DT5	12.6 129	B346 50VW	10 7JKS
12EN6	12.6 A123	456 25Z	10 2LLNS

TUBE TYPE	SEC.	A.	B.	C.	D.	SHORTS	E.
3DK6	P	3.0	3	X	1567	2	30
4DK6	P	4.2	3	X	1567	2	30
6DK6	P	6.3	3	X	1567	2	30
12DT5	P	12.6	4	6	139	7	5
12EN6	P	12.6	2	-	345	8	4

Latest Chart Form 648-19, 115/715/561-10, 49-3

**"Preferred Type" Audio Tubes**

Amperex Electronic Corp. is now marketing a series of tubes (Fig. 13) developed especially for audio applications by Phillips of the Netherlands. Among this series are three tubes which are electrically identical to the standard 12AU7, 12AT7 and 12AX7 tubes of American design. These tubes, the ECC81/12AT7, ECC82/12AU7 and ECC83/12AX7, have a number of important performance features that make them superior to their standard counterparts when used for high-quality audio work.

The inherent hum level is lower due to the double helical filament winding which provides for mu-

for the  
**MOSLEY Flush Mount TV Socket**

**LOW LOSS**  
**NEAT**  
**EFFICIENT**



MODEL F-1PK

● The tremendous demand for portable TV sets opens another BIG market for good set-to-antenna plug-in outlets. MOSLEY Flush Sockets meet this need—supplying attractive, convenient, customer-approved wall outlets for every installation requirement.

Without MOSLEY TV Outlets, portable TV—in most areas—ceases to be portable! Let MOSLEY TV Outlets spark YOUR Portable TV Sales!

For a complete line of up-to-date TV Accessories and Electronic Components send for our "57" catalog.

**Mosley Electronics Inc.**  
 8622 ST. CHARLES ROCK ROAD  
 ST. LOUIS 14, MISSOURI

*Modernize!... Simplify!...* your billing methods with the  
**No. 225**  
 RADIO · TV · APPLIANCE  
**REPAIR ORDER**

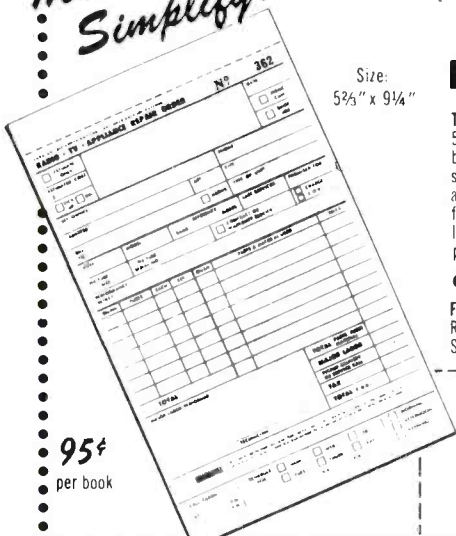

Size: 5 3/8" x 9 1/4"

THE COMPLETE SERVICE FORM for shop jobs or home calls. 50 triplicate sets in sales book style with detachable numbered claim check. "Not At Home" note and appointment schedule. Promissory note on backer #2 and #3. Guarantee and performance guarantee on back copy #1. 15 lines on face, 16 on backers. Blank heading for your rubber stamp. Imprinted with 4 line imprint on special order at attractive prices. See it at your parts jobber!

OR WRITE FOR FREE SAMPLE #225 FORM  
 FREE 24 PAGE CATALOG TOO! showing complete line of Service Reports, Statements, Job Tickets, Phone Message Books, File Systems, Warranties, etc.

**Oelrich Publication** 4308 N. MILWAUKEE AVE. CHICAGO 41, ILLINOIS  
 Please send **FREE**  SAMPLE #225 FORM  CATALOG

Name \_\_\_\_\_  
 Address \_\_\_\_\_  
 City \_\_\_\_\_ Zone \_\_\_\_\_ State \_\_\_\_\_

95¢ per book

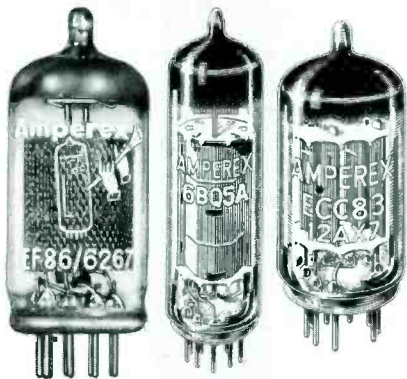

Fig. 13. "Preferred" type audio tubes.

tual cancellation of magnetic fields. This type of construction also reduces filament burn-out because it eliminates sharp bends where hot spots are most likely to occur. Lower tube noise and increased freedom from microphonics results from greater rigidity of the internal tube structure made possible by special manufacturing techniques.

Also included in the "preferred" type category is the EF86/6267, which is a 9-pin miniature pentode designed for preamplifier input stages. This tube is a direct plug-in

replacement for the older Z729. In the power output classification, the 6BQ5A, also listed as a preferred type, is designed to produce over 20 watts of audio with only 4% distortion when used in well designed push-pull stages.

#### Magnetic Tape Preamplifier

The Model 6010 magnetic tape preamplifier (Fig. 14) manufactured by Electro-Voice, Inc., is a 3-stage transistorized unit of the plug-in variety. The unit is compensated to the NARTB curve  $\pm 7$  db, 20 cps—20 kc and features

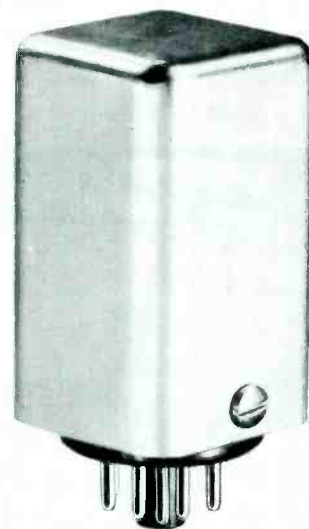

Fig. 14. E-V magnetic tape preamplifier.

42 db of gain at 1 kc. Low-noise precision resistors and selected transistors are used, insuring a low-noise output of only 400  $\mu$ v. Other specifications for the Model 6010 include a maximum signal output of 1.5V rms, input impedance of 40K, output impedance of 15K and a maximum operating temperature of 40° C.

The unit is contained entirely within an aluminum shield which measures only 1 $\frac{3}{8}$ "  $\times$  1 $\frac{3}{8}$ "  $\times$  2 $\frac{5}{8}$ " and is supplied with an octal base for easy installation. Power requirements are very low (6V at 1 ma) which, along with its small size and plug-in feature, make this unit a natural for eliminating complaints of insufficient recording gain.

Just a word here—since this unit is equalized and the existing preamp in a tape recorder will also have equalization, the latter should be removed when the additional preamp is installed. ▲

**Our  
Guarantee  
is printed  
on our  
product**



**On every packaged PLANET electrolytic capacitor sold through distributors you will find this statement:**

### GUARANTEED FOR ONE YEAR

Because PLANET CAPACITORS ARE "ENGINEERED FOR QUALITY", because they are carefully controlled through all stages of production and because the finished product is given a 100% electrical and mechanical check—our one-year guarantee is not only made possible, but is conservative.

Actually thousands and thousands of Planet capacitors five, six and even seven years old are performing excellently, every day, in TV and radio sets all around the world. When you solder a Planet capacitor into a circuit your guarantee of satisfactory performance is right there in front of you—and will be in the circuit for a long, long time. So when you order capacitors—order PLANET.

## PLANET SALES CORPORATION

227 BELLEVILLE AVE.

BLOOMFIELD, NEW JERSEY

# Let's Talk Business

## Your wife can run your business



Many a service dealer schemes and plans to buy tremendous amounts of life insurance to assure a comfortable living for his wife in case he should die. He may even go so far as to arrange for the sale of his business. But he probably overlooks the best legacy he can leave to assure her protection and welfare—the shop itself.

"Impossible," a friendly shop-owner told us when we expressed this opinion. "My wife knows nothing about business at all. Sure, she understands some of the routine here, but she couldn't carry on herself. She would lose everything for sure."

Knowing this man's wife, we are dead certain he is wrong. He felt her lack of service knowledge was the stumbling block, and forgot completely that service technicians can always be hired. Given half a chance, nine out of ten shop owners' wives could carry on the business successfully and would also be capable of running it properly by themselves should the shop owner become ill or laid up for a lengthy period.

"I'm glad I realized this years ago," another shop owner told us recently. "It's saved me lots of headaches and worry. I figured that it would take over \$100,000 plus inheritance tax money to give my wife the security this business can provide. In my opinion, every shop owner should do the same thing."

We asked how he worked out his program and also discussed this with shop owners who have made certain their wives will be

able to continue their business profitably should they pass away. The combined suggestions are presented herewith point by point.

If the owner's wife unfortunately falls into the category of women who have absolutely no head for business, the owner should make special provisions for training someone to follow in his footsteps, either on a salary basis or with a partnership in the business itself. One shop owner has set up a trust agreement whereby his lawyer handles the details of hiring the actual manager and consults with the wife on major business decisions in order to keep the shop operating.

If your wife shows some interest, however, it's important to start right now in giving her as complete and as active an interest in the business as possible, considering her other duties.

"My wife and I have worked it out this way," explains one man, "—since we have a family to raise, she can't be around the place too much. But I never make a decision without telling her about it, why I did it, the probable effect and the whole background."

"At the dinner table and after closing hours we talk over all of the things that have happened during the day. She now has a mighty good idea of what to do in case anything should happen to me, either through illness or death."

Several other shop owners have their wives spend one day a week at the business. Needless to say, these women enjoy getting away from household chores and having

a part in the business. Usually, part or all of the bookkeeping is assigned to the wife since this function will offer a woman considerable training in management.

"My wife says she is helped most by the trade journals," another explains. She has agreed to carefully read every page each month, and she and her husband discuss the ideas contained therein which apply to their own operation. He volunteers with a smile that, though this is her only close contact with the business today, it has enabled her to offer scores of good ideas.

There are, of course, many physical tasks we perform in the operation of a shop that would be difficult for a woman to do. Our course of "training" covering these phases of the shop operation is to be certain that she understands what we are doing, how and why, so that she can intelligently hire someone to do these chores in case we are gone. If a woman has such knowledge, she will be able to select the right type of workman and see that he does the job properly.

The helplessness and inability of a woman in carrying on her husband's business usually results solely from her lack of experience or background in the business. The shop owners referred to in earlier paragraphs all emphasize the importance of giving their wives this background while they still can.

Selection and purchasing of supplies and materials is all done with the wives' co-operation. Thus, the women not only receive practical training in methods of doing this, but also learn something about the economic factors affecting each purchase.

Setting up a definite program for continuation of the business is also suggested. With such a program planned in detail, one's wife can take over with much less uncertainty even should one be suddenly hospitalized or not available to run the business. Without it she is suddenly handed something about which she has given little thought, and she must take time to orient herself before stepping in and filling the void.

A program of this nature should set down definite steps she is to follow in every possible emer-

# Focus on Profits

with  
**Centralab**<sup>®</sup>  
**Model B**  
**Controls**



Enlarge your income and develop a long list of satisfied customers. It's easy with Centralab Model B Radiohms in the picture.

This is a replacement carbon control that adapts readily to virtually any application. Universal, fluted, knurled-type shaft fits all knobs—split knurl, shallow flat, deep flat, half-round, round, etc.

AC Line switches snap on, to convert control to switch-type unit.

There's nothing negative about Model B's . . . and you'll get a double exposure of profits. Order today from your Centralab distributor.

Centralab products are listed in COUNTERFACTS and PHOTOFACTS.

**Centralab**<sup>®</sup>  
B-5806

A DIVISION OF GLOBE-UNION, INC.  
942 E. KEEFE AVE. • MILWAUKEE 1, WIS.  
In Canada: 804 Mt. Pleasant Rd. • Toronto, Ontario

**CONTROLS • SWITCHES • PACKAGED ELECTRONIC CIRCUITS  
CERAMIC CAPACITORS • SEMI-CONDUCTOR PRODUCTS**

gency. The phases of the business which she obviously cannot handle should be delegated to others or placed in the hands of someone she can hire to handle these chores. Many businessmen make it a point to keep in touch with such individuals and to make certain their wives are informed that "Mr. So and So" can be hired to handle these chores should the need arise. Obtaining an individual who is available on a moment's notice is not always easy, and planning ahead helps make certain of his presence. Actual designation of the individual will change from time to time, of course. Finding "someone to lean on" is best handled by having someone on the payroll whom we are training for just such an emergency.

It is also good procedure to realize that one's wife may have to face decisions which we cannot possibly foresee. Most of these fall into definite classifications. Shop-owners who carefully plan on this subject make certain that their wives know individuals who can help them on different problems. Specific examples would include the bank official who can be trusted to advise her on financial matters, the insurance man on phases covering his field, and other such individuals including a lawyer, accountant and other professional men whose services we use in the operation of our business at present.

The shop owner will also find it wise to instill in his wife a definite desire to continue on with the business. No matter what plans he may make, none can reach fulfillment if the "little woman" has no desire to do so or has not been instilled with that desire beforehand. Usually the lack of interest stems from the fact that she has in the past been left out of the business entirely. Fortunately, however, this can be overcome through obvious measures.

Remember—any reasonably intelligent woman can continue the managerial functions of a service business with the aid and assistance of the type of advisers mentioned above. The technical problems she cannot handle can easily be turned over to hired individuals. ▲

# PRODUCT report

## Copper Alloy Solder



What is the real cause of wear and corrosion of soldering iron tips? Most people assume that the copper tip simply oxidizes because of the heat of soldering. But there's another important possibility—the molten solder itself could be dissolving the copper right out of the tip. Figuring that this dissolving action is the major cause of wear, a British company has developed a solder already containing copper in addition to tin and lead. Since it already "has its fill" of copper, it doesn't draw more from the tip. Heavy-duty use on production lines in England has demonstrated that the new alloy actually does make tips last longer. At left in the "before-and-after" picture is an iron which made 1,000 solder joints using a tin/lead alloy, and at right is another iron which made ten times as many joints with the new alloy.

Multicore Sales Corp., a division of British Industries Co., Port Washington, N. Y., is distributing the new solder under the trade name of "Savbit." It is supplied with five flux cores in either 14, 16, or 18 gauge. Melting point is practically the same as that of the normal tin/lead alloy.

## Improved UHF Oscillator Tube

One of the major drawbacks to UHF reception has been the short life of 6AF4 oscillator tubes. Because of the extremely small element size and spacing needed to overcome inductive and transit-time effects above 470 mc, these tubes have an unusually high current density which tends to limit their life span.

At long last, however, the tube has been redesigned to make it last much longer. By combining new materials with improved manufacturing and testing techniques, the receiving tube department of General Electric Co., Owensboro, Ky., has developed a version of the 6AF4 which has racked up some fine performances on life tests.

These tests are conducted with reduced line voltage in order to simulate the worst operating conditions found in the field. Results are shown in the graph, in which oscillator grid current is plotted against hours of operation. Grid current (an index of the tube's worth as an oscillator) begins to decline immediately in the old-type 6AF4 and reaches a level which renders the tube useless in less than 1,000 hours. On the other hand, even the poorest

**Which one can prove her QUALITY?**

Most brands of twin lead look alike! Also, the price brands make the same claims of quality and performance as the top quality brands.

**What Reason . . . What Proof**  
Can you give your customer that he is getting something better when he pays a little more for twin lead?

## WITH Columbia PERMALINE

Your Customer has the reason

So GOOD that it's  
GUARANTEED up to 25 YEARS!

DISTINCTIVE APPEARANCE

HIGH MOLECULAR WT. POLYETHELENE

DEVELOPED AFTER YEARS OF RESEARCH

See your Jobber Ask him about Permaline — and ask to see the Laboratory Report on weathering studies of Polyethelene.  
Once you "Try" COLUMBIA . . . you'll want to always "Buy" Columbia . . . Because only, but only COLUMBIA gives you a complete guarantee for 25 YEARS.

AVAILABLE AT ALL LEADING DISTRIBUTORS

Columbia  
WIRE & SUPPLY CO.

2850 IRVING  
PK. RD.,  
CHICAGO 18

**\$21 WILL GET YOU  
8 NEW HATS FOR YOUR  
WIFE OR \$47 WORTH OF  
3 CENT STAMPS**

Ask About Duotone's

"68" Deal. Contains:

8 RCA Needles

8 SONOTONE Needles

8 RONETTE Needles

**Biggest Profit Deal  
in the Trade**

**DUOTONE COMPANY, INC.**

Keyport, New Jersey



In Canada—Charles W. Pointon, Ltd.

# FOR A brighter

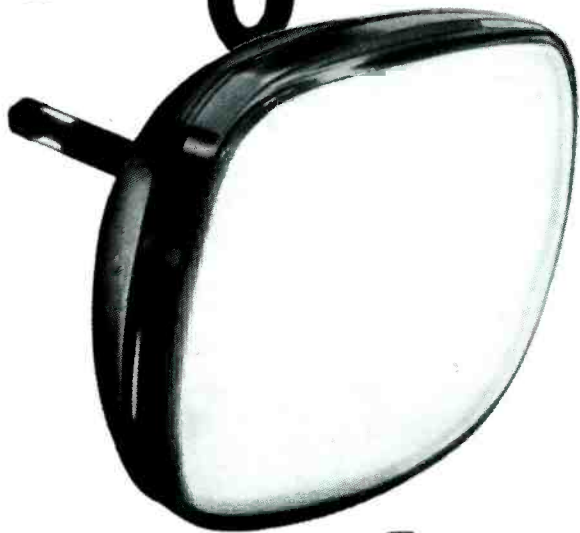

# TV picture

Rely on the tube that has always been specified by leading independent set makers.

*Blue Chip Quality*  
**TUNG-SOL**<sup>®</sup>  
 Magic Mirror Aluminized  
**PICTURE TUBES**

TUNG-SOL ELECTRIC INC., Newark 4, N. J. Sales Offices: Atlanta, Ga.; Columbus, Ohio; Culver City, Calif.; Dallas, Tex.; Denver, Colo.; Detroit, Mich.; Irvington, N. J.; Melrose Park, Ill.; Newark, N. J.; Seattle, Wash.

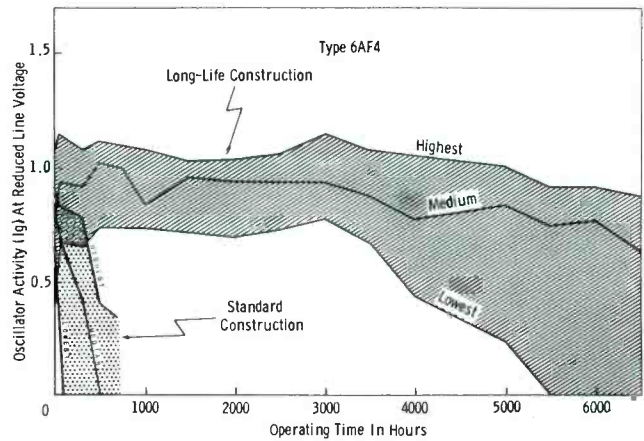

tubes of the new design are holding up for more than 3,000 hours on life tests, and the best of the new tubes have oscillated continuously for over 6,500 hours.

### Audio Pre-amplifier



The Model PA-110 Pre-Amplifier manufactured by Dynamic Electronics-New York, Inc., Forest Hills, L. I., N. Y., is designed to amplify the low-level output signal of a variable reluctance pickup or tape recorder head for application to a hi-fi amplifier. Specifications include: Frequency response, 11 to 25,000 cps  $\pm 1.5$  db; over-all gain, 34 db; noise and hum level, 60 db below 10 mv; power consumption, 15 watts; dimensions, 6"  $\times$  3 $\frac{1}{4}$ "  $\times$  3 $\frac{1}{2}$ "; weight, 2 $\frac{1}{2}$  lb.; list price, \$12.95.

signal of a variable reluctance pickup or tape recorder head for application to a hi-fi amplifier. Specifications include: Frequency response, 11 to 25,000 cps  $\pm 1.5$  db; over-all gain, 34 db; noise and hum level, 60 db below 10 mv; power consumption, 15 watts; dimensions, 6"  $\times$  3 $\frac{1}{4}$ "  $\times$  3 $\frac{1}{2}$ "; weight, 2 $\frac{1}{2}$  lb.; list price, \$12.95.

### Push-Pull Switch

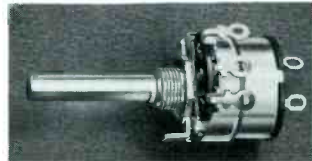

A push-pull AC line switch, a popular feature in many new TV and radio sets, is now available on volume controls manufactured by P. R. Mallory & Co.,

Inc., Indianapolis, Ind. Advantages of the new design are that equipment can be turned off without disturbing the volume setting, and excessive wear on the low end of the control element (common in rotary-switch units) is eliminated. The push-pull switches, which feature a "floating ring" contact, are available on single and dual controls in assorted ratings.

### Picture Tube Defect Corrector



Anchor Products Co., 2712 W. Montrose, Chicago, Ill., has marketed a "Universal TV Picture Tube Kure-all" which is claimed to cure picture-tube defects such as open cathodes, heater-to-cathode shorts, open or shorted control grids, slow heating, and low emission, or combinations of these faults. The UK 200 "Kure-all," which can be used with either series or parallel heater circuits, has a list price of \$5.50.

and low emission, or combinations of these faults. The UK 200 "Kure-all," which can be used with either series or parallel heater circuits, has a list price of \$5.50.



### Metallized Mylar Capacitors



Small, relatively low-cost metallized "Mylar" capacitors (Type RLR) have been introduced by Astron Corp., East Newark, N. J. Protection against humidity is provided by a Mylar wrap and epoxy resin end seal. These components are available with a continuous voltage rating of 200 WVDC and an operating temperature range of  $-55^{\circ}$  to  $125^{\circ}$  C.

### Control-Grid Checker



Seco Mfg. Co., Minneapolis, Minn., has just released the Model GCT-8, an improved version of the GCT-5 Grid Circuit Tube Tester. In this unit, a tube is simultaneously checked for grid emission, gas, and interelement shorts. Presence of any of these defects produces a "Bad" reading on the eye-tube indicator. Ten pre-wired test sockets and a spare are included, and a selector switch provides all standard values of heater voltage from 2 to 12 volts.

### New Sweep Components



Chicago Standard Transformer Corp., Chicago, Ill., announces several additions to its line. New flybacks HO-276, -7 and -8 replace Philco part numbers 32-8624/-1, 32-8465-2, 32-8509/-2, 32-8484-2 and 32-8695/-1, and another flyback, HO-279, replaces Magnavox part 360632-1. New  $90^{\circ}$  deflection yoke DY-24A (pictured) replaces RCA parts 103114 and 972913, and yoke DY-25A replaces Emerson part 708288.

### Self-Service Tube Checkers



"U-Check-'Em" customer-operated tube checkers, manufactured by Affiliated Television Labs., Inc., Queens Village, N. Y., are being offered to service technicians through electronic parts distributors. Three types are available—a console with tube storage compartment, a deluxe table model (shown), and a standard table model. Features include a  $7\frac{1}{2}$ " meter with "Good-?-Bad" scale, 40 phosphor bronze tube sockets, pin straightener, customer control for filament voltage, and an illuminated attention-getting sign with sales message that automatically changes when a customer walks by the machine.

# FOR A brighter



# profit picture

Rely on the tube that has always been a favorite with leading independent service dealers.

*Blue Chip Quality*  

**TUNG-SOL<sup>®</sup>**  
**RECEIVING TUBES**

TUNG-SOL makes All-Glass Sealed Beam Lamps, Miniature Lamps, Signal Flashers, Picture Tubes, Radio, TV and Special Purpose Electron Tubes and Semiconductor Products.

Advertisers	Page No.
Acme Electric Corp.	40
American Television & Radio Co. (ATR)	53
Amphenol Electronics Corp.	52
Astron Corp.	5
Audio Devices, Inc.	4
B & K Mfg. Co.	11, 27
Bussmann Mfg. Co.	39
Centralab, A Div. of Globe-Union, Inc.	68
Chicago Standard Transformer Corp.	62
Clarostat Mfg. Co., Inc.	33
Colman Tool & Machine Co.	64
Columbia Wire & Supply Co.	69
Cornell-Dubilier Electric Corp.	55, 56
Delco Radio Div., General Motors Corp.	29
Duotone Co., Inc.	69
Dynamic Electronics, New York, Inc.	61
EICO	64
Electronic Publishing Co.	51
E-Z-Hook Test Products	64
General Cement Mfg. Co.	23
General Electric Co.	18-19, 37
International Resistance Co. (IRC)	2nd Cover-1
Jackson Electrical Instrument Co.	65
Jensen Industries, Inc.	64
Jersey Specialty Co., Inc.	59
Kedman Co.	53
Kingston Electronic Corp.	8
Littelfuse, Inc.	4th Cover
Mallory & Co., Inc., P. R.	34, 35
Merit Coil & Transformer Corp.	51
Mosley Electronics, Inc.	65
Oelrich Publications	65
Ohmite Mfg. Co.	49
Planet Sales Corp.	66
Quam-Nichols Co.	58
R-Columbia Products Co.	51
Radiart Corp.—Cornell-Dubilier Electric Corp.	54, 56
Raytheon Mfg. Co.	9
RCA Components Division	47
RCA Electron Tube Division	3rd Cover
Sams & Co., Inc., Howard W.	17, 48, 60
Service Instruments Corp.	46, 51, 61
Simpson Electric Co.	41
Sprague Products Co.	2
Sylvania Electric Products, Inc.	6-7
Tenna Mfg. Co.	30
Tobe Deutschmann Corp.	57
Triplett Electrical Instrument Co.	25
Tung-Sol Electric, Inc.	70, 71
United Catalog Pubs., Inc.	53
Utah Radio Products Corp.	63
Walsco Electronics Corp.	36
Webster Electric Co.	31
Westinghouse Electric Co.	43
Winegard Co.	28
Winston Electronics, Inc.	45
Wright Steel & Wire Co., G. F.	42
Wuerth Tube-Saver Corp.	46
Xcelite, Inc.	42

CATALOG and LITERATURE SERVICE

ANTENNAS

1N. TELCO—Catalog No. A-58 shows a complete range of over 100 different types of antennas. See ad page 23.

BUSINESS PROMOTION

2N. WESTINGHOUSE—"This is the story of a TV set," a pamphlet which is part of a "Build Consumer Confidence" kit. See ad page 43.

CAPACITORS

3N. ASTRON—Handy pocket-sized AC4-D, Replacement Catalog and Pricing Guide for servicemen. See ad page 5.

4N. TOBE DEUTSCHMANN—Catalog on capacitor line. See ad page 57.

CONTROLS

5N. IRC—Form S-067—IRC Merchandising Guide. See ad 2nd Cover and page 1.

DIAL LIGHTS

6N. UNITED CATALOG PUBLISHERS—Panel and flashlight lamp chart shows bulb type, base, volts, amps, and bead color with illustrations and physical dimensions. See ad page 53.

FUSES

7N. BUSSMANN—Form TVC, complete TV Fuse Chart. Shows fuse to use on all TV sets and auto radios. See ad page 39.

MICROPHONES

8N. ELECTRO-VOICE—Catalog 126 (new), "Public Address & General Purpose Microphones."

NEEDLES

9N. JENSEN INDUSTRIES—Complete kit of Jensen needle sales aids. See ad page 64.

POWER SUPPLIES

10N. ACME—Variable Voltage Adjustor Catalog VA312. See ad page 40.

PROBES

11N. E-Z-HOOK—A convenient reference sheet titled "How to Build the Five Most Useful Scope Probes" with schematic, mechanical component layout, etc. See ad page 64.

SPEAKERS

12N. GENERAL CEMENT—Rear Seat Speaker Brochure FR-3050. See ad page 23.

TECHNICAL READING

13N. CBS-HYTRON—Catalog Sheet on Technician's and Engineer's Handbooks.

14N. PF REPORTER—"Troubled by Color Codes?" A 2-page reprint from October, 1957 issue.

TEST EQUIPMENT

15N. B & K—Bulletin 1050 tells how you can transmit video and audio to any TV set with Model 1050 Dyna-Scan. Bulletin 650 describes the Model 650 Dyna-Quik

portable dynamic mutual conductance tube and transistor tester. Bulletin 400-C40 describes CRT Cathode Rejuvenator Tester. See ads pages 11, 27.

16N. CLAROSTAT—Power Resistor Decade Box—225 Watts, 1 to 999,999 ohms in 1-ohm steps—Form No. 755259. See ad page 33.

17N. EICO—12-page catalog shows how to save 50% on electronic test instruments and hi-fi equipment in both kit and factory-wired form. See ad page 64.

18N. HICKOK—4-page technical brochure covering the new low-price Cardmatic, Portable Automatic Tube Tester.

19N. JACKSON—Folder covering the entire Jackson line of "Service Engineered" test equipment. See ad page 65.

20N. KINGSTON—"Puts Money in the Pockets of TV Servicemen" a 4-page, two-color brochure, gives details on the operation of the Kingston Absorption Analyzer. See ad page 8.

21N. SERVICE INSTRUMENTS—New 2-color folder of all Sencore products. See ads pages 46, 51, 61.

22N. SIMPSON—Catalog of panel meters (Bulletin 2057), catalog on test equipment (Bulletin 2058) and new 260 Bulletin. See ad page 41.

23N. SPRAGUE—Form No. M-737, 4-page brochure explaining the new features of the Model TO-5 Tel-ohmike capacitor analyzer. See ad page 2.

24N. TRIPLETT—Volt-ohm-milliammeter circular. See ad page 25.

25N. WINSTON—One-page flyer on full line of equipment. See ad page 45.

26N. WUERTH—New Model 125 Electronic Tube-Saver described by Catalog Sheet #CA110, showing its many applications. See ad page 46.

TOOLS

27N. KEDMAN—Catalog sheet describing 4 screwdriver displays and specifications of 14 kinds of screwdrivers in the company's line. See ad page 53.

28N. XCELITE—Illustrated catalog listing complete line of hand tools. See ad page 42.

TRANSFORMERS

29N. CHICAGO STANDARD—New 1958 Stancor TV Transformer Replacement Guide. See ad page 62.

30N. MERIT—Form No. 700 Exact Replacement Wall Chart. See ad page 51.

WIRE

31N. JERSEY SPECIALTY—New brochure covering 20-strand, 400-mil wide, and 10-strand, 385-mil wide, 300-ohm wire. See ad page 59.

32N. WRIGHT—Complete details on galvanized guy wire strand—various types and sizes. See ad page 42.

# ENTER THE EXCITING RCA "MYSTERY SHOPPER" CONTEST!

# You Can Win One of 192 Big Awards!



- 8 MGA SPORTS ROADSTERS
- 24 COLOR-TV SETS
- 80 HI-FI PHONOGRAPHS
- 80 TRANSISTOR RADIOS

...and every TV service-dealer and technician who enters this exciting "contest" receives a gift—just for entering!

## Here's How:

1. To enter the contest, write a statement of 50 words or less telling how you think RCA's promotion of "National Television Servicemen's Week" benefits the independent TV service industry. The contest is open to all radio-television service dealers and their service employees, in the continental U. S., Alaska, and Hawaii, without any obligation on their part.
2. Your entry must be made on an official entry blank and must be submitted in your own name describing your own opinions in connection with "National Television Servicemen's Week"—March 24th to 29th, 1958. You may prepare your own entry blank, or you can ask your RCA Tube Distributor Salesman to help you prepare your entry blank. If your distributor salesman does help you, be sure to have him countersign your entry blank—he is also eligible for a prize if you win. Official entry blanks are available from your Authorized RCA Tube Distributor and from RCA Electron Tube Division advertisements. Only one entry per person is permitted.
3. Mail your entry, using adequate postage to: RCA Electron Tube Division, P.O. Box 551, New York 46, N. Y.

All entries must be postmarked on or before midnight, March 15, 1958. No general correspondence should be sent to this address.

4. The entries will be judged by Advertising Distributors of America, Inc., an impartial, independent contest judging organization, on the basis of originality, sincerity, and aptness of thought. Decision of the judges is final. All entries become the property of Radio Corporation of America, and none will be returned. Entry in the contest constitutes permission to RCA to use your name and entry in any way it sees fit.
5. The contestants will be ranked in each region, in the order of the merit of their entries, as determined by the judges as provided above. They will be visited in person or phoned, in succession, sometime between the period of April 1, 1958 and April 30, 1958, by a "Mystery Shopper". The "Mystery Shopper" will ask a question about the product features of RCA Silverama Picture Tubes or RCA Receiving Tubes. The first service dealer or service technician in each region who answers the question correctly will be presented with the grand award. The next 3 dealers or their service employees in each region

who answer the question correctly will be awarded one of the beautiful, new RCA Victor color TV sets. An additional 10 contestants in each region who answer the "Mystery Shopper" question correctly will receive one of the exquisite RCA Victor High Fidelity Sets. And 10 additional contestants in each region who answer the question correctly will receive an RCA Victor Transistor Radio. All contestants will receive a token of recognition.

6. The "Mystery Shopper" is the name applied to a group of impartial employees of Advertising Distributors of America, Inc., located throughout the nation. The "Mystery Shopper" will visit or phone contestants in the guise of a consumer, and will not divulge his or her identity unless the contestant supplies the correct answer to the question asked by the "Mystery Shopper".
7. Only one award will be made per person. Duplicate awards will be made in the event of a tie. This contest is subject to state and local regulation. Void if taxed, restricted or forbidden by law. A list of award winners may be obtained after April 30, 1958 by sending a stamped, self-addressed envelope to the address given above.

## OFFICIAL ENTRY FORM

B-33

Mail to:

**RCA ELECTRON TUBE DIVISION  
P.O. Box 551, New York 46, N. Y.**

Complete this statement in 50 words or less:

As a service dealer, this is how I think RCA's promotion of "National Television Servicemen's Week" benefits the independent TV service industry:

---



---



---

**ALL ENTRIES MUST BE POSTMARKED ON  
OR BEFORE MIDNIGHT MARCH 15, 1958**

SIGNED \_\_\_\_\_  
(Signature of Dealer or Technician)

\_\_\_\_\_  
FIRM NAME

\_\_\_\_\_  
ADDRESS

\_\_\_\_\_  
CITY

\_\_\_\_\_  
ZONE

\_\_\_\_\_  
STATE



**RADIO CORPORATION OF AMERICA**  
Electron Tube Division  
Harrison, N. J.

See your Authorized RCA  
Tube Distributor now for  
additional details!



IT'S NO GAMBLE WITH...

# LITTELFUSE

*Quality, Service, Range, and such winning service aids as the Fuse Caddy, One-Call Kits, LC Fuse Caddy, Packaged Snap-On Holders, Fuse-Retainer Assortments, Single-Fuse Channels, participation in Howard Sams Photofact Folders.*

# LITTELFUSE

*Des Plaines, Illinois*