

MARCH • 1956

25 CENTS

*Howard W. Sams*

# PHOTOFACT REPORTER

for the Electronic Service Industry

TROUBLES IN  
AGC CIRCUITS

STOCKING THE  
TUBE KIT

ALIGNMENT TOOLS  
AND THEIR USES

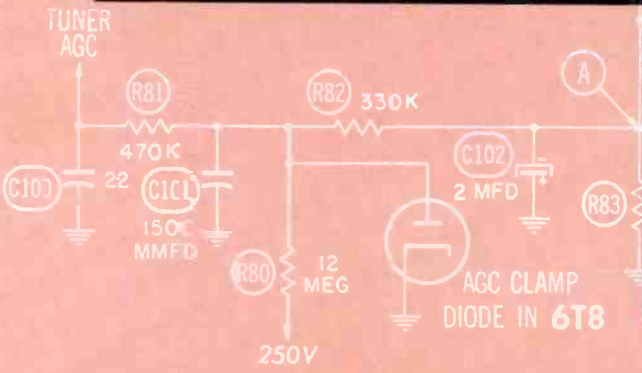
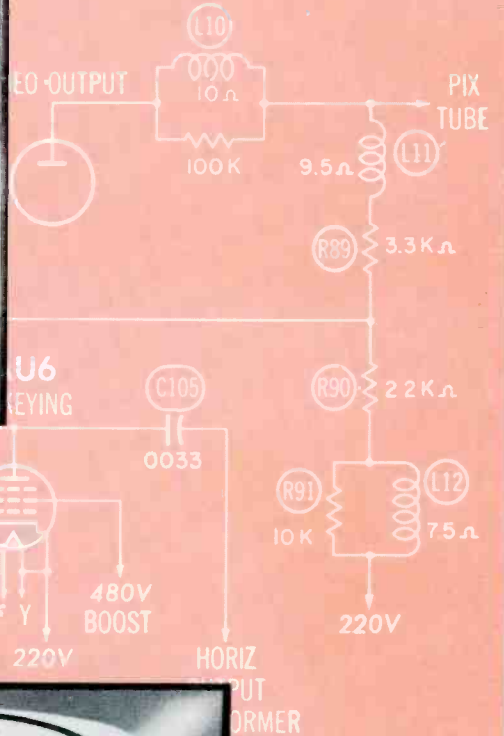
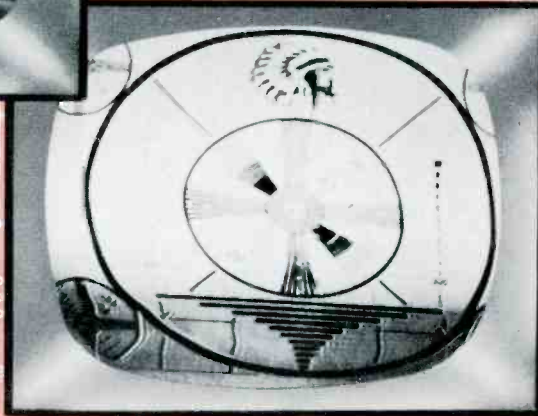
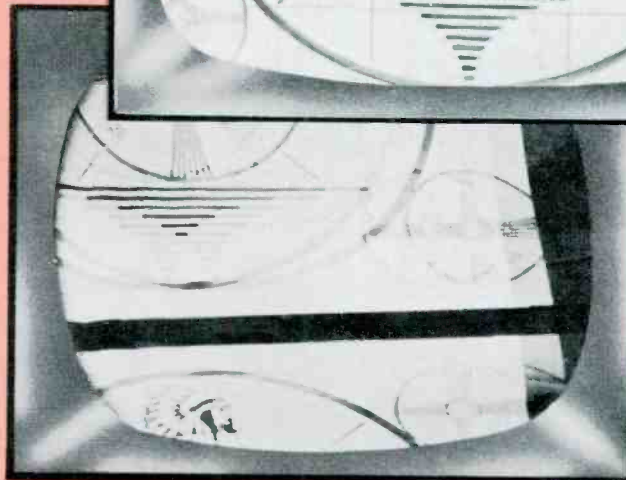
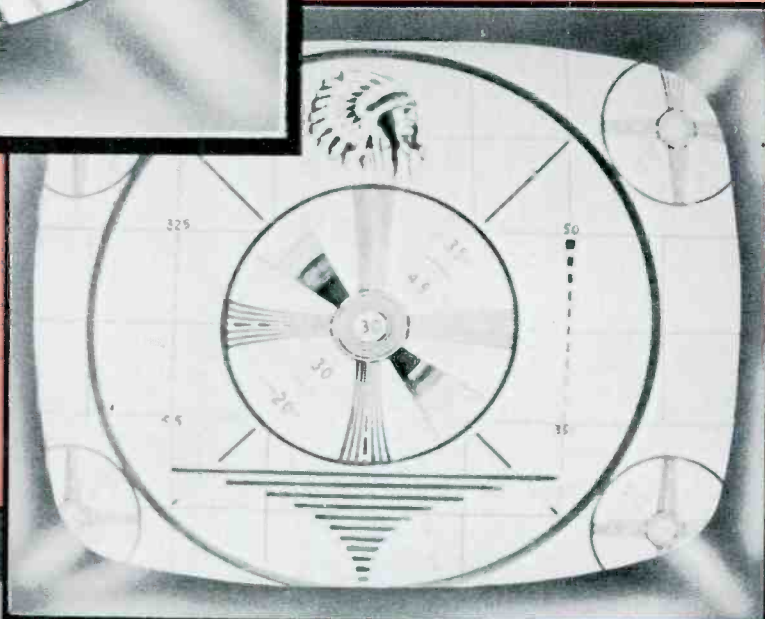

# Preferred for modern set servicing

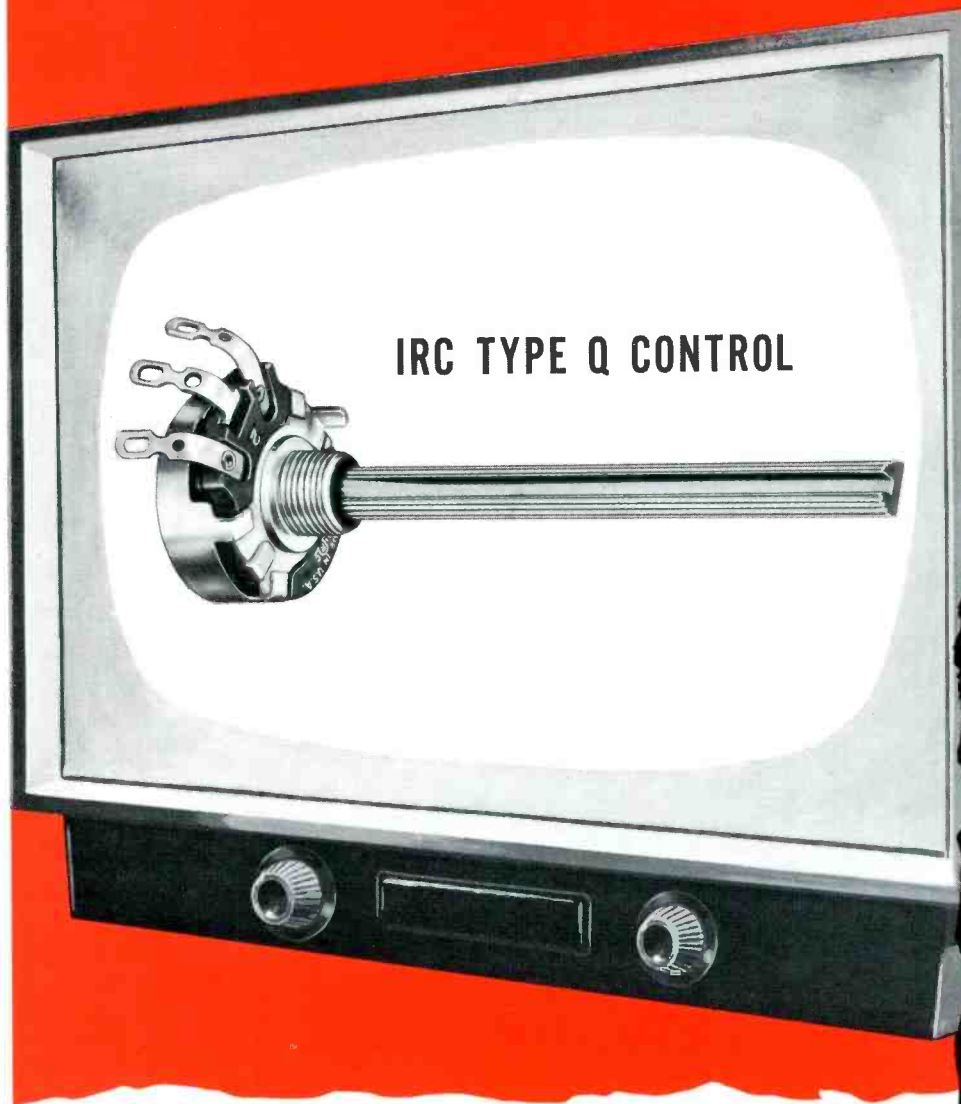

IRC TYPE Q CONTROL

Service technicians get greater coverage with less investment; more practical service features; and easier, faster installation with the IRC Type Q Control. Here's a dependable, basic control that is directly designed for modern set servicing. For appearance, performance and price . . . there's none better. So why settle for less? Tell your Distributor you want Q Controls . . . most servicemen do.

## INTERNATIONAL RESISTANCE CO.

Dept. 369, 401 N. Broad St., Phila. 8, Pa.

In Canada: International Resistance Co., Ltd., Toronto, Licensee

Send me Catalog listing IRC Type Q Controls.

Name \_\_\_\_\_

Company \_\_\_\_\_

Address \_\_\_\_\_

City \_\_\_\_\_ State \_\_\_\_\_

**KNOBMASTER FIXED SHAFT**  
Q Control standard shaft is knurled, flatted and slotted — fits most knobs without alteration.

**INTERCHANGEABLE FIXED SHAFTS**  
Exclusive IRC convenience feature — provides fast conversion to "specials", with FIXED shaft security. 15 types available.

**1/4" LONG BUSHING**  
Accommodates all small sets, yet handles large set needs perfectly.

**7 STANDARD TAPERS**  
Full coverage of all taper requirements is provided in the Q Control.

**94 RESISTANCE VALUES**  
For TV, AM and FM coverage, 94 values of plain and tapped controls are furnished.

**QUALITY APPEARANCE**  
The handsome professional appearance of IRC Q Controls lets you point to your work with pride.

**CUSHIONED TURN**  
The smooth, quality of "feel" of a Q Control contributes to customer confidence.

**TYPE 76 SWITCHES**  
Either of two type IRC switches attached as quickly and easily as a control cover — meets all your requirements.







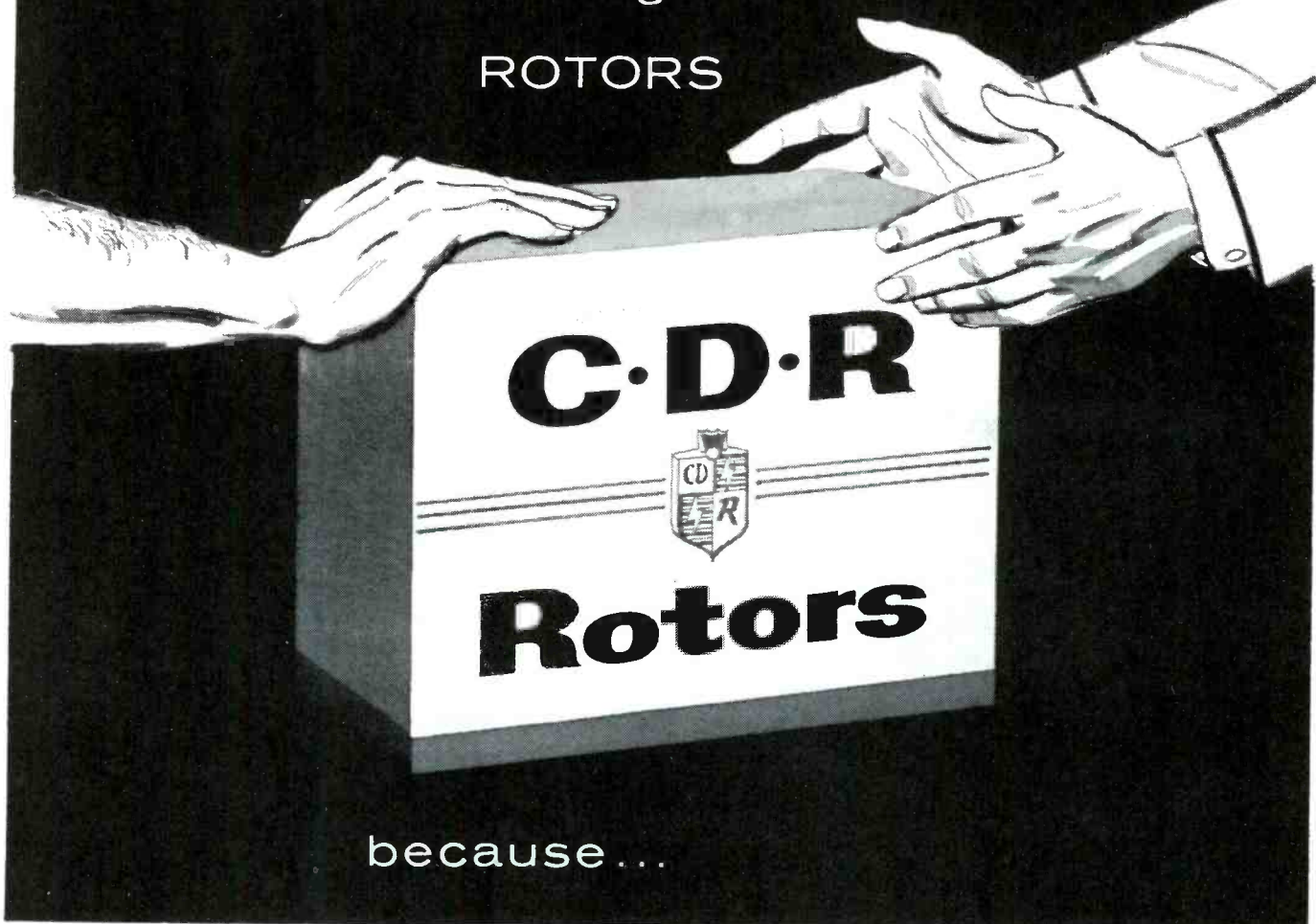







Wherever the Circuit Says

the fastest selling  
ROTORS

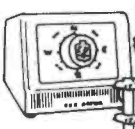

because ...

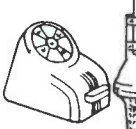
- ✓ Pre-Sold to millions every week on TV
- ✓ The Most Complete Line ... A Model for Every Need
- ✓ Superior Engineering ... they're Tried-Tested-Proven

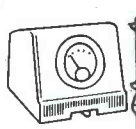
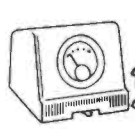
 <b>AR-22</b>	 <b>AR-1</b>	 <b>AR-2</b>	 <b>TR-2</b>	 <b>TR-4</b>	 <b>TR-12</b>	 <b>TR-11</b>
						
<p>Completely AUTO-MATIC version of the TR-2 with all the powerful features that made it famous.</p>	<p>Completely AUTO-MATIC rotor, powerful and dependable. Modern design cabinet. 4 wire cable.</p>	<p>Completely AUTO-MATIC rotor with thrust bearing. Handsome cabinet, 4 wire cable.</p>	<p>Heavy-duty rotor with plastic cabinet, "compass control" illuminated perfect pattern dial, 8 wire cable.</p>	<p>Heavy-duty rotor, modern cabinet with METER control dial, 4 wire cable.</p>	<p>Combination value ... complete rotor with thrust bearing. Modern cabinet with meter control dial, uses 4 wire cable.</p>	<p>Ideal budget all-purpose rotor, new modern cabinet featuring meter control dial, 4 wire cable.</p>



**CORNELL-DUBILIER**  
SOUTH PLAINFIELD, N. J.



**THE RADIART CORP.**  
CLEVELAND 13, OHIO

# Sprague Salutes the Independent Service Dealer

Ask your distributor  
for big, window-size  
blow-ups of this ad,  
or write directly to  
Sprague Products Co.,  
North Adams, Mass.,  
on your letterhead.

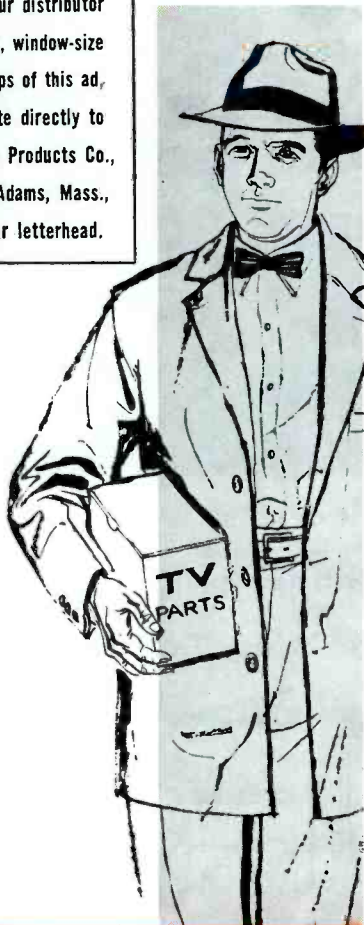

## HERE'S TO THE MAN

- ... who assures your enjoyment of the best entertainment in the land.
- ... who competently and conscientiously keeps your TV and radio in top operating condition.
- ... who has become a specialist in his chosen field like your doctor, lawyer, or dentist.
- ... who has the finest service equipment to operate his own business in your home community.
- ... who stands alone ... serving no other boss than you, the customer.
- ... who has earned your patronage, respect, and confidence as an important asset to the community he serves.

**YOU CAN DEPEND ON THIS MAN**

**SPRAGUE**

WORLD'S LARGEST MANUFACTURER OF ELECTRONIC COMPONENTS

®



**PUBLISHER**  
Howard W. Sams

**EDITOR**  
Lester H. Nelson

**MANAGING EDITOR**  
Glen E. Slutz

**TECHNICAL EDITOR**  
William E. Burke

**EDITORIAL STAFF**

Leslie D. Deane	C. P. Oliphant
Robert B. Dunham	Verne M. Ray
Thomas A. Lesh	Paul C. Smith
George B. Mann	Calvin C. Young, Jr.

**EDITORIAL ASSISTANTS**

Phyllis J. Hurley	Evelyn S. Mouser
-------------------	------------------

**ART DIRECTORS**

Anthony M. Andreone	Glenn R. Smith
---------------------	----------------

**PHOTOGRAPHY**  
Robert W. Reed

**PRODUCTION**  
Douglas G. Bolt                      Charles A. Ferguson



**ABOUT THE COVER**

Cover photographs illustrate symptoms explained in the article, "Troubles in AGC Circuits," by Leslie D. Deane and Calvin C. Young, Jr., on page 9.

Cover design by Glenn R. Smith.

**BUSINESS DEPARTMENT**

Donald B. Shaw, V. P.  
F. T. Dobbs, Secretary  
Joe H. Morin, Sales Mgr.  
Ann W. Jones, Advertising

**ADVERTISING SALES OFFICES**

Midwestern: Joe H. Morin, Sales Manager,  
2201 East 46th Street, Indianapolis 5, Ind.  
Glendale 4531

Eastern: Paul S. Weil and Donald C. Weil,  
39-01 Main Street, Flushing 54, New York.  
Independence 3-9098.

Western: The Maurice A. Kimball Co., Inc.,  
2550 Beverly Blvd., Los Angeles 57, Calif.  
Dunkirk 8-6178; and 681 Market Street,  
San Francisco 5, Calif. EXbrook 2-3365.

**PUBLICATION INFORMATION**

Published monthly by Howard W. Sams & Co., Inc., at Indianapolis, Indiana.

Entered as second class matter October 11, 1954, at the Post Office at Indianapolis, Indiana, under the Act of March 3, 1879.

Copyright 1956 by Howard W. Sams & Co., Inc. No part of the PFREPORTER may be reproduced without written permission. No patent liability is assumed with respect to the use of information contained herein.

A limited quantity of back issues are available at 35c per copy.

**CONTENTS**

**Troubles in AGC Circuits.** . . . Leslie D. Deane and Calvin C. Young, Jr. 9  
A servicing guide arranged by symptoms

**Alignment Tools and Their Uses** . . . . . George B. Mann 12  
A photographic coverage

**Shop Talk** . . . . . Milton S. Kiver 15  
Power transistors

**In the Interest of Quicker Servicing** . . . . . Calvin C. Young, Jr. 17  
Hum problems; replacement of obsolete focus coils; hints on tubes; control of line voltage

**Brakes and Tape Tension** . . . . . Robert B. Dunham 18  
Proper adjustments of tape recorders

**Notes on Test Equipment.** . . . . . Paul C. Smith 20  
Simpson Model 434 Varidot white-dot generator; Simpson Model 548 coloroscope; low-capacitance probes

**Examining Design Features** . . . . . Leslie D. Deane 23  
Crosley transistor radio; Philco cosmetic-bag radio; CBS-Columbia Highway Hi-Fi

**Audio Facts** . . . . . Robert B. Dunham 25  
Directional characteristics of microphones

**Time Constants.** . . . . . Verne M. Ray 27  
Theory of RC circuits

**Chemical Aids to Servicing.** . . . . . Thomas A. Lesh 29

**Dollar and Sense Servicing.** . . . . . John Markus 33

**Stocking the Tube Kit** . . . . . 37

**Product Report** . . . . . 62

Please enter my subscription to PF REPORTER for:

<input type="checkbox"/> 1 Year \$3.00	<input type="checkbox"/> 2 Years \$5.00	<input type="checkbox"/> 3 Years \$7.00
--	---	---

In Canada: One Year \$3.60                      Two Years \$6.20                      Three Years \$8.80

<input type="checkbox"/> Remittance Enclosed*	<input type="checkbox"/> Bill Me
---	----------------------------------

\*Two extra issues if remittance accompanies order.

Name \_\_\_\_\_

Firm \_\_\_\_\_

Address \_\_\_\_\_

City \_\_\_\_\_ Zone \_\_\_\_\_ State \_\_\_\_\_

01 <input type="checkbox"/> Independent Service Man	12 <input type="checkbox"/> Service Manager
02 <input type="checkbox"/> Dealer with Service Shop	37 <input type="checkbox"/> Student
38 <input type="checkbox"/> Other _____	

Give to your Electronic Parts Distributor or mail, with remittance, to PF REPORTER, 2201 East 46th Street, Indianapolis 5, Indiana.

**for Safe**  
**“Trouble-free”**  
**Electrical**  
**Protection**

**Standardize**  
**on BUSS Fuses!**



Today, Industry, the Trade and the Public accept BUSS fuses without question. The BUSS reputation for fuses of unfailing dependability has been established over the past 41 years by millions upon millions of BUSS fuses used in homes, on farms, in industries, as well as in electronic equipment.

To assure top quality and proper operation under all service conditions — every BUSS fuse normally used by the Electronic Industries is tested in a sensitive electronic device. Any fuse not correctly calibrated, properly constructed

and right in all physical dimensions is automatically rejected.

That's why you can rely on BUSS fuses to open and prevent further damage to equipment when there is trouble on the circuit. And just as important, BUSS fuses will not cause needless shutdowns by blowing when trouble doesn't exist.

There's a complete line of BUSS fuses and fuseholders available. So be profit wise — and rely on dependable BUSS fuses to help safeguard the good name of your product or service as surely as they protect users.

Makers of a complete line of fuses for home, farm, commercial, electronic, automotive, and industrial use.

**BUSSMANN MFG. CO.**

University at Jefferson,

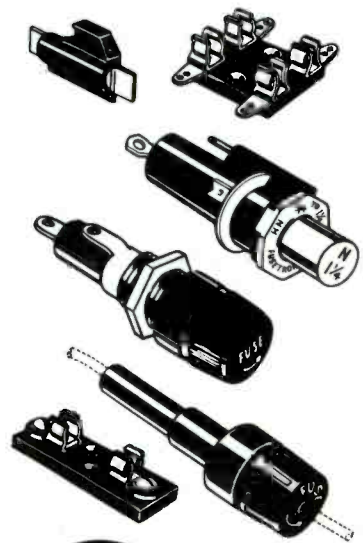

Div. of McGraw  
 Electric Co.

St. Louis 7, Mo.

in perfect mesh  
with **your** business



**BALLAST RESISTORS  
FUSE-TYPE RESISTORS  
LINE-VOLTAGE REGULATORS**

CLAROSTAT resistance devices are designed to meet **your** needs in radio and television servicing. Voltage regulators serve as safeguards against line-voltage surges, and are popular, essential accessories. Ballast tubes serve as fuses in many television receivers and are expendable, easy-to-replace components. Fuse-type resistors are being used by television receiver manufacturers and should be on every serviceman's parts list. Get the complete story on these CLAROSTAT products designed to fill your needs, from your distributor.

**CLAROSTAT MFG. CO., INC., DOVER, NEW HAMPSHIRE**  
In Canada: Canadian Marconi Co., Ltd., Toronto, Ont.

don't be a  
circuit  
juggler..

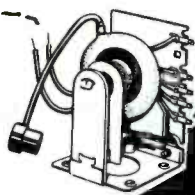

use  
**STANCOR**  
**EXACT**  
**REPLACEMENT**  
**FLYBACKS**

You just remove  
the old flyback  
and install the new one . . . No  
circuit changes are necessary  
. . . Even the leads are the  
proper length for quick, easy  
installation.

**FREE:** STANCOR  
TV Transformer Re-  
placement Guide listing  
over 8000 models and  
chassis of 117 manu-  
facturers . . . available  
from your distributor or  
by writing Chicago  
Standard.

**CHICAGO STANDARD TRANSFORMER CORPORATION**  
**3503 ADDISON STREET • CHICAGO 18, ILLINOIS**

Export Sales: Roburn Agencies, Inc., 431 Greenwich Street, New York 13, N. Y.



# ONLY **RAYTHEON** PICTURE TUBES ...

## give you these major advantages

### CROSS-CHECK CONTROL

Raytheon Picture Tubes are *right* when you get them, thanks to RAYTHEON'S CROSS-CHECK QUALITY CONTROL. This comprehensive Raytheon quality control method includes daily tests made on tubes for pressure, base torque and outside coating adhesion. Engineering controls check screen color and brightness and tube life under both ideal and extremely adverse conditions. And, most important of all, a substantial percentage of every day's production is actually *unpacked and tested for physical appearance and electrical characteristics* before quality control headquarters will permit release of a single tube for shipment.

### CORONA INHIBITOR

This Raytheon development insures brightness rain or shine. Ordinary tubes lose up to 10% of their brightness on humid, damp days. Not so, Raytheon Picture Tubes. Tests prove *no loss of brightness* even under a water spray on the high voltage contact — thanks to *Corona Inhibitor*.

## ALUMINIZED

with

# Lumilac

LUMILAC — a lacquer especially blended and used exclusively by Raytheon — is the secret of the superiority of Raytheon Aluminized Picture Tubes. This amazing lacquer produces an extra smooth, unbroken surface for the pure aluminum coating, yet leaves no gas-producing residues which could impair cathode emission and shorten tube life.

The result — all the benefits of aluminized tubes, sharper picture, superior contrast, high light output — *plus excellent tube life.*

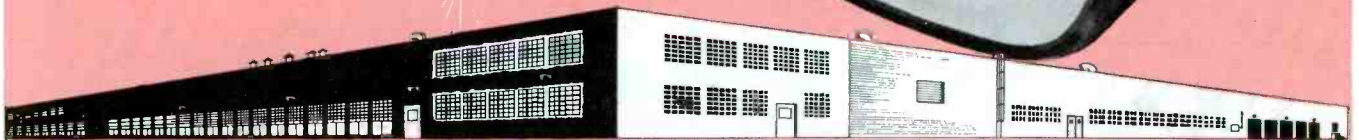

Raytheon Picture Tubes have the distinct advantage of precision production in one of the world's most modern plants. The Raytheon Cathode Ray Tube Plant in Quincy, Mass. houses some of the world's largest equipment and was designed and built solely for the manufacture of today's large screen Raytheon Picture Tubes.



## RAYTHEON MANUFACTURING COMPANY

Receiving and Cathode Ray Tube Operations

Newton, Mass. • Chicago • Atlanta, Ga. • Los Angeles, Calif.

Raytheon makes all these

Receiving and Picture Tubes, Reliable Subminiature and Miniature Tubes, Semiconductor Diodes, Power Rectifiers and Transistors, Nucleonic Tubes, Microwave Tubes



Excellence in Electronics

# WIRE

## FOR EVERY

### ELECTRONIC

### PRODUCT

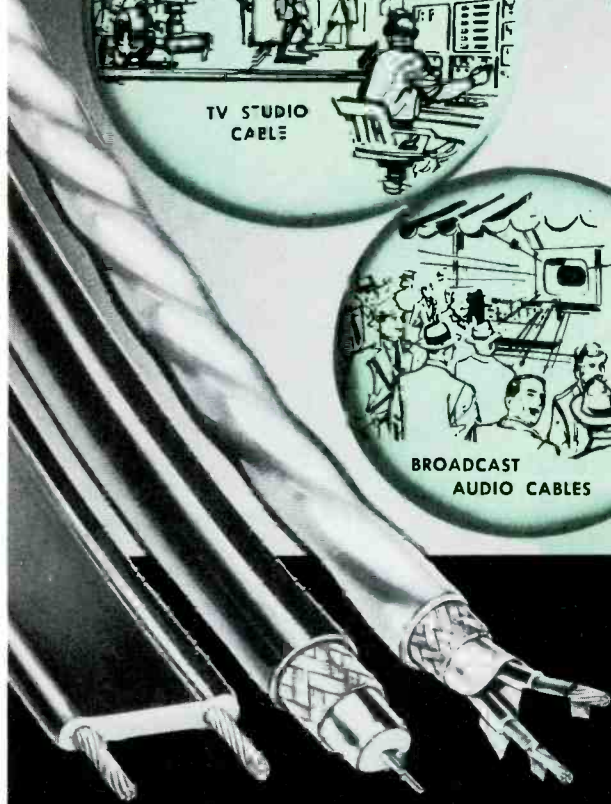
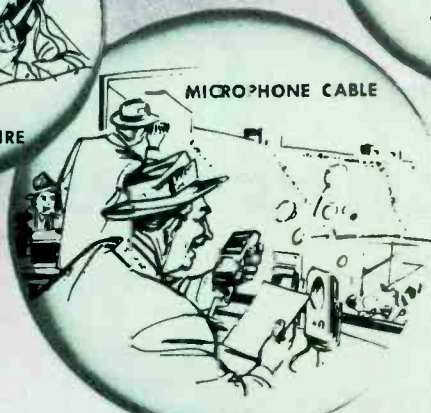
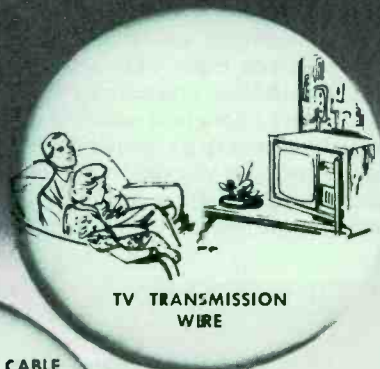

# Belden

WIREMAKER FOR INDUSTRY  
SINCE 1902

CHICAGO

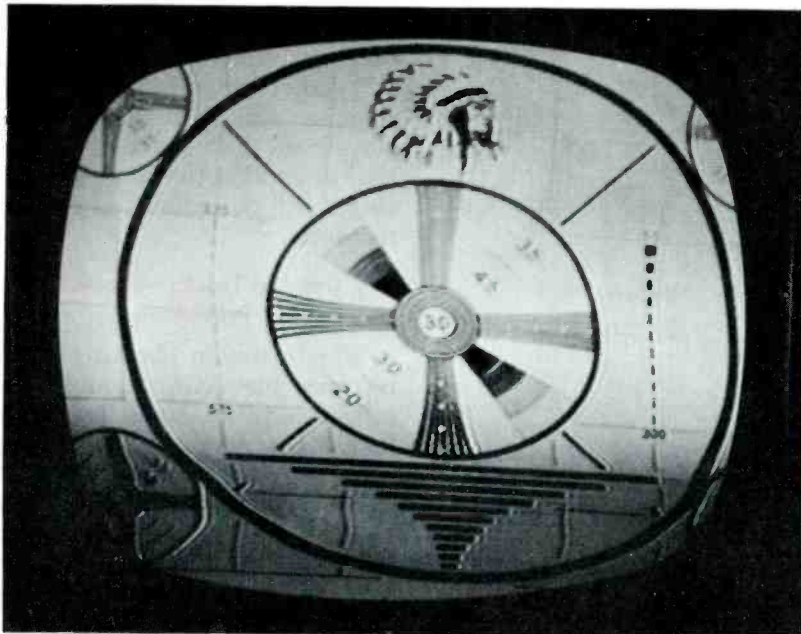

# TROUBLES in AGC circuits

**A Servicing Guide  
Arranged by Symptoms**

**BY LESLIE D. DEANE  
and CALVIN C. YOUNG, JR.**

In principle, the AGC system in a TV receiver has the same function as an AVC system in a radio receiver. The AGC system is the control device which makes it possible for the TV receiver to handle both strong and weak signals without manual adjustment of the gain. In addition to this, some of the more complex and elaborate AGC systems have the property of being able to reduce the effects of airplane flutter and other types of interference. AGC systems vary from the simple rectified to the more elaborate keyed types. The troubles encountered in AGC circuits are generally associated with certain symptoms either in the sound, in the picture, or in both.

The following list contains five of these symptoms, and each will be dealt with in detail.

1. Negative picture.
2. Raster, no sound, no picture.
3. Loss of synchronization.
4. Dark picture with buzz in audio.
5. Pulling picture with brightness modulation.

### General Discussion

In actual practice, there are several different AGC circuits being used. The simplest of these is the system that employs only rectification and filtering. This system is shown in Fig. 1. Notice that the AGC circuit uses the video-detector diode. This is probably

the simplest form of an AGC system because it involves only a minimum number of components. A more elaborate rectified AGC system that features a delay and clamping network in the AGC line to the tuner is shown in Fig. 2.

In either of these circuits, the AGC voltage is produced by rectification of the video signal that is present at the video detector. This rectified signal is then filtered and applied to the required RF and IF stages through a suitable network of decoupling resistors and bypass capacitors. The delay and clamping network in Fig. 2 consists of the 10-megohm resistor R47 and the diode (which is one unit of a 6T8 tube).

Another variation of a rectified AGC system is employed in certain TV receivers. This variation is called amplified AGC and consists of a DC amplifier in addition to the AGC rectifier. A schematic diagram of such a system is shown

in Fig. 3. Notice that a delay and clamping network is also employed in this AGC system. The AGC bias voltage is produced by amplification and filtering of the rectified sync-pulse signal that is applied to the AGC rectifier grid. The AGC control serves to set the limits within which the AGC voltage can vary.

The most elaborate form of an AGC circuit in current use is the keyed AGC system that incorporates a delay and clamping network. See Fig. 4. The AGC voltage in this system is produced by the conduction through the keyer tube. The amount and time of conduction through the keyer tube is determined by the amplitude of the grid signal and by the width or duration of the plate signal. Since the plate signal is constant, the output voltage from the keyer tube will vary directly with any change of the grid signal. The voltage produced by the keyer

**Fig. 1. Rectified AGC System.**

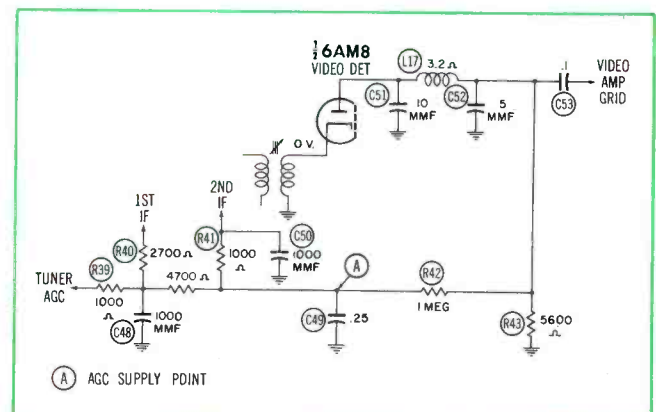

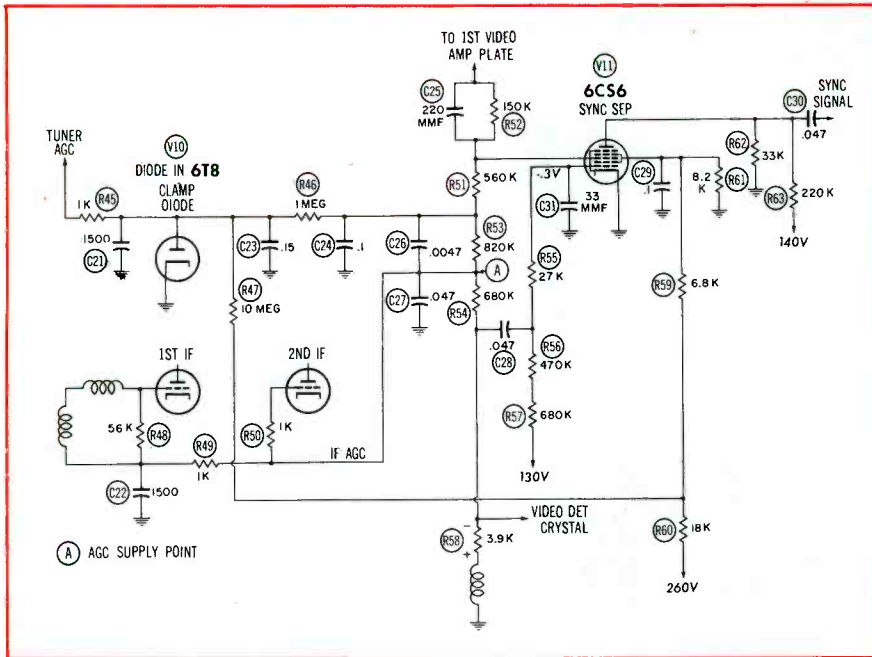

Fig. 2. Rectified AGC System That Employs a Delay and Clamping Network in the Tuner Line.

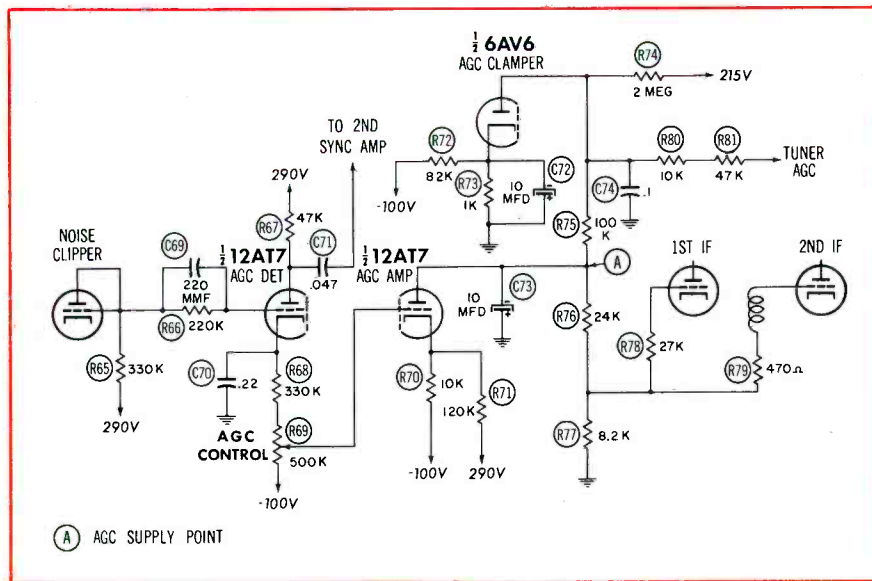

Fig. 3. Amplified AGC System.

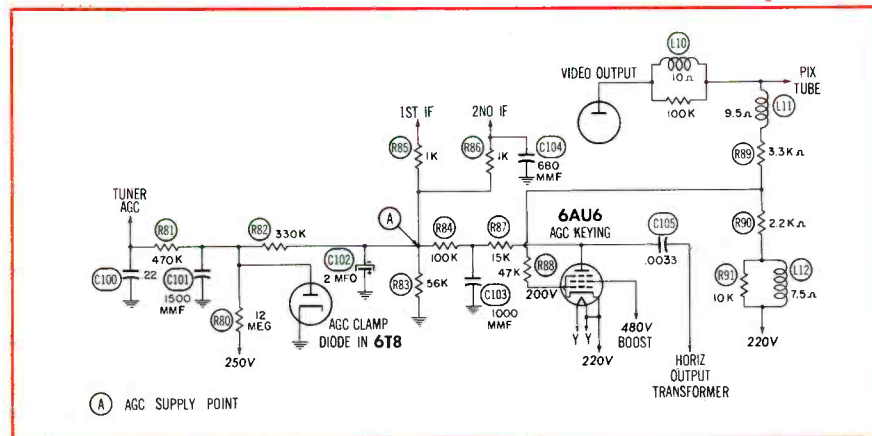

Fig. 4. Keyed AGC System.

stage is usually more than is actually required to bias the IF and RF stages properly; therefore, a resistive divider network is employed so that the bias voltage that is applied to the IF and RF stages will be reduced to the correct level.

### General Trouble-Shooting Procedure

When trouble shooting a TV receiver for AGC trouble, the suspected tubes should be checked first. A new AGC keyer or rectifier tube should be tried; and if this fails to correct the trouble, then new RF and video IF tubes should be tried in turn. In amplified AGC systems, new AGC rectifier and amplifier tubes should be tried. It is assumed that all of the operating controls on both front and rear panels of a receiver were checked for proper operation prior to any other trouble-shooting procedure.

After eliminating the tubes of the receiver as a possible source of the trouble, the next step is to clamp the AGC line with a negative voltage from either a battery pack or a small AC powered bias supply. A voltage that is variable from 0 to -45 volts will usually be suitable for most applications. A schematic diagram of a suitable battery pack is shown in Fig. 5. When the AGC line of a receiver that employs keyed AGC is being clamped, the keyer stage should be disabled to prevent any erroneous indications from this source.

If the receiver employs a parallel filament arrangement, the AGC keyer can be disabled by removal of the keyer tube. If the receiver employs a series filament arrangement or if the keyer tube is part of a multisection tube, the keyer stage may be disabled by connecting a .1-mfd, 600-volt capacitor between the keyer plate and the chassis. Such a capacitor with alligator clips affixed to each end, as shown in Fig. 6, makes this step much easier. If the AGC line is being clamped, the bias pack should be connected to the AGC line at the AGC supply point which is indicated in Figs. 1, 2, 3, and 4 by the letter A enclosed in a circle.

If the trouble is in the AGC circuit, then clamping the AGC line

at a reasonable level should produce a normal picture. The amount of voltage which should

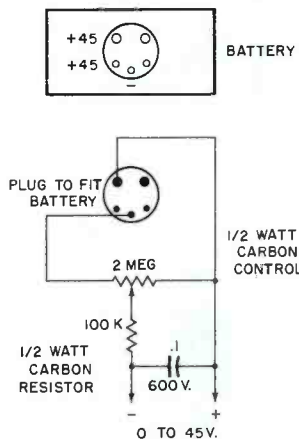

Fig. 5. Battery Pack for AGC Trouble Shooting.

be used to clamp the AGC line depends on several factors. The two major ones are: the signal level in your area and the type of AGC circuit. In strong-signal areas, the amount of voltage will be greater for all types and the keyed AGC systems will require more voltage than the rectified systems. The voltage required for your particular area will be known by experience with normally operating receivers. If clamping the AGC line with a reasonable amount of voltage produces a normal picture, it can be assumed that the trouble is in the AGC network.

The photograph shown in Fig. 7 is a normal test pattern and is presented as a basis for comparison of the patterns produced by various troubles.

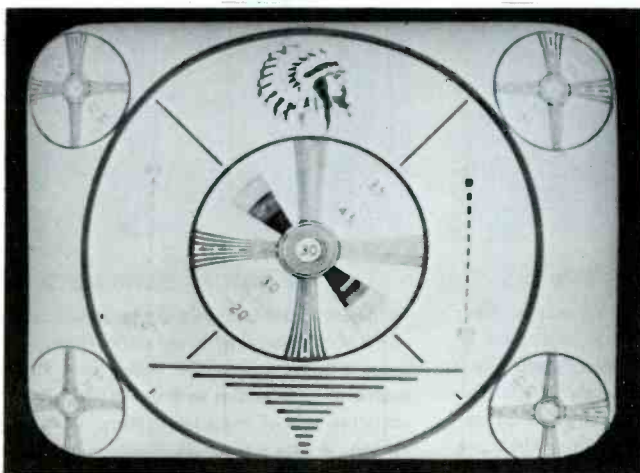

Fig. 7. Normal Test Pattern.

## Common Symptoms

### 1. Negative Picture.

A negative picture which is the result of faulty AGC action is illustrated in Fig. 8. A negative picture results when a lack of AGC voltage causes one or more stages in the tuner, IF, video detector, or video amplifier stages to be overdriven, in which case the video signal may become inverted.

Possible causes of a negative picture are:

- AGC switch or control improperly adjusted.
- Defective rectifier, amplifier, keyer, or clamper tubes in the AGC circuit.
- Defective RF, mixer, or video IF tubes.
- Defective video detector tube or crystal.
- Defective video or sync amplifier tube (in keyed AGC systems).
- Positive voltage on AGC line. This is caused by a change of value of the delay resistor in circuits that do not employ a clamp tube.
- Low AGC voltage to the tuner. This is caused by a change of value of the delay resistor in circuits that do employ a clamp tube. (See R47 in Fig. 2, R74 in Fig. 3, and R80 in Fig. 4.)
- Loss of AGC voltage. This is caused by loss of the pulse signal to the AGC keyer plate. This could be caused

by a faulty coupling capacitor. (See C105 in Fig. 4.)

- Loss of AGC voltage. This is caused by a defective component in the AGC line. (Resistors and capacitors that make up the filter and distribution network for the AGC voltages are the most common offenders.)

In a receiver that employs a keyed AGC system, the AGC voltage is dependent upon the video

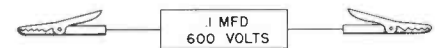

Fig. 6. Capacitor to Disable AGC Keyer Tube.

signal and the video signal is dependent upon the AGC voltage. This reaction, in which the failure of either the AGC voltage or the video signal causes the failure of both, must be broken if a trouble-shooting procedure is to be effective in the search for the source of the AGC trouble. A clamp on the AGC line does this. The grid signal on the AGC keyer tube may then be checked. The pulse signal to the keyer plate should also be checked because the loss of this pulse will also cause a loss of AGC voltage. After the signals to the keyer stage have been checked, the DC voltages applied to the keyer stage should be checked. Generally, the cathode and filament are connected to a source of low B+ voltage and the screen grid to a source of voltage high enough that the screen grid is 100 to 150 volts positive with

• Please turn to page 74

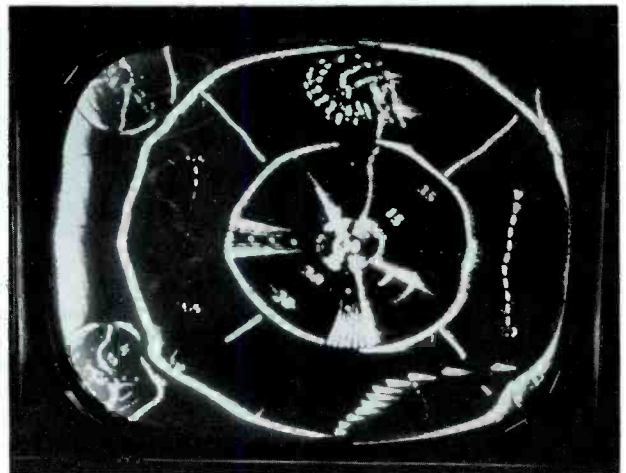
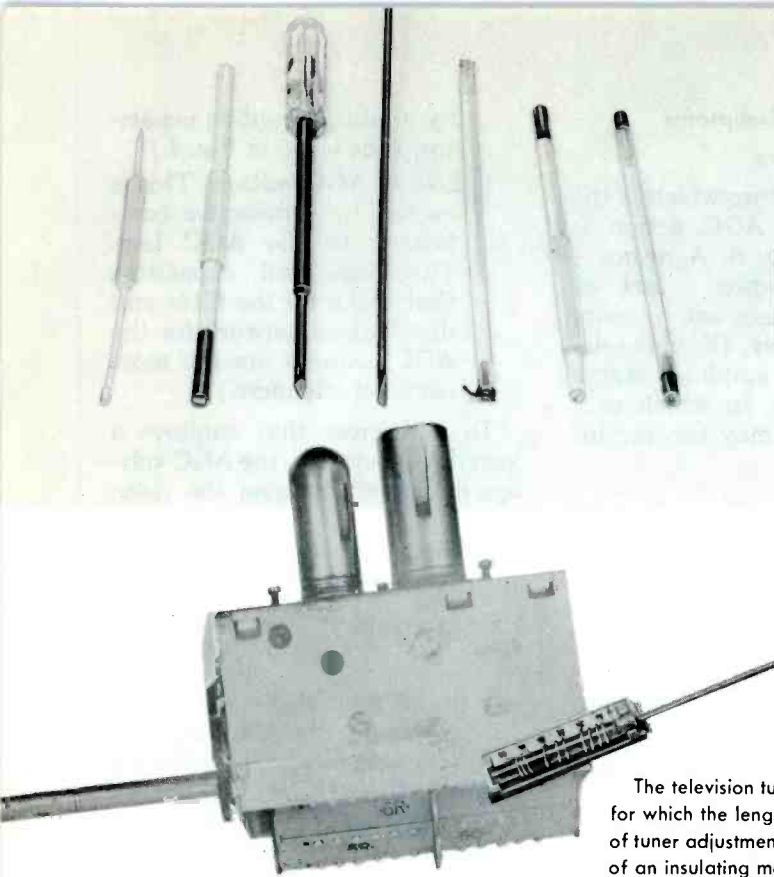

Fig. 8. Negative Picture.

# Alignment Tools and Their Uses

by George B. Mann



## TUNER ALIGNMENT TOOL

The television tuner presents a good example of an alignment operation for which the length of the tool is of prime importance. In nearly all cases of tuner adjustment, the shaft and tip of the alignment tool must be formed of an insulating material and must also be long enough to provide access to the alignment screw inside the tuner.

Many varieties of alignment tools are available to the service technician. Not all of these tools are needed in every service organization, but the various tuning arrangements which are employed in present equipment make it important for the technician to have at least one alignment tool for each type of adjustment.

The handles and shafts of the various tools have different physical shapes which provide maximum accessibility for the different tuning adjustments and which also conform to the differences in personal preference. The most important part of each tool is its tip, and this must fit the adjustable component to which it is being applied. The number of basic tip designs is surprisingly small.

The primary functions of alignment tools are to provide accessibility, ease of tuning, and accuracy of setting. The over-all shape of the tool provides ease of access to the adjustable component. The tip is shaped to distribute the pressure effectively to the adjustment point and also to prevent damage to the adjustable component or the tool.

Combinations of insulating materials and metals are used in constructing alignment tools so that either the insulation or the mechanical rigidity required by a particular alignment procedure will be provided.

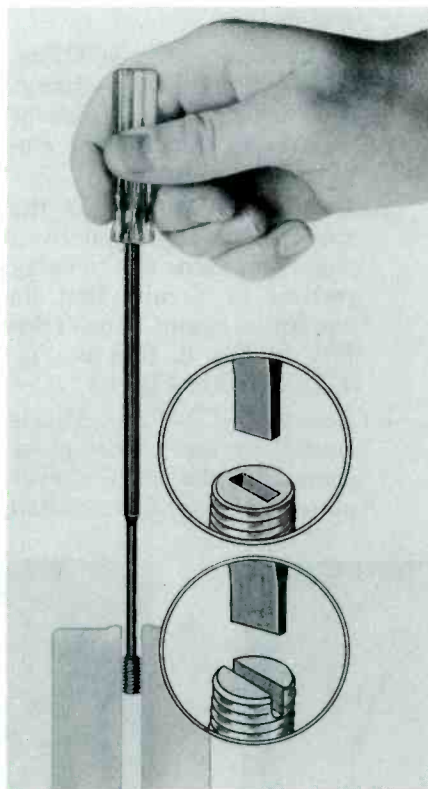

## TIP FOR SLOTTED CORE

Alignment tools made of plastic or fiber should be used to adjust the slotted types of powdered-iron cores. These tools should have a blade shape which will completely fill the core slot in order that an even pressure will be applied to the sides of the slot. Blades which are too small will cause chipping and cracking of the core material.

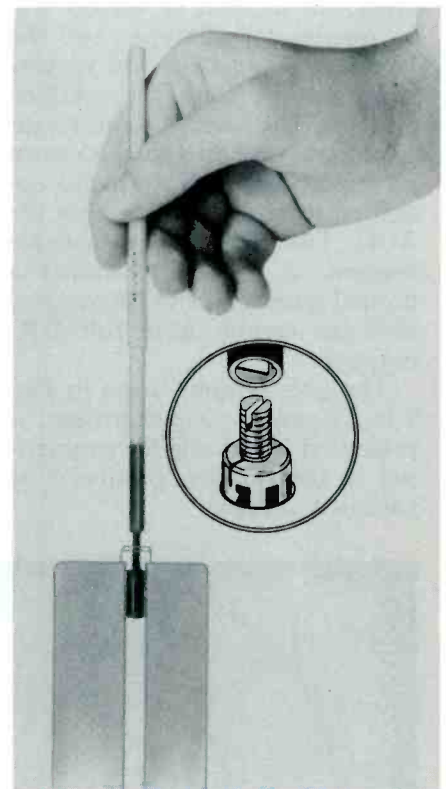

## TIP FOR SLOTTED BRASS SCREW

The alignment tool used to tune a slotted brass screw is composed of a thin metal blade which is set into the end of the tuning rod. The rim around the blade acts as a guide and also prevents the end of the slotted screw from being broken. A screwdriver or exposed blade will sometimes break off the sides of the slot. Alignment tools are available in sizes to fit Nos. 6, 8, and 10 slotted screws.

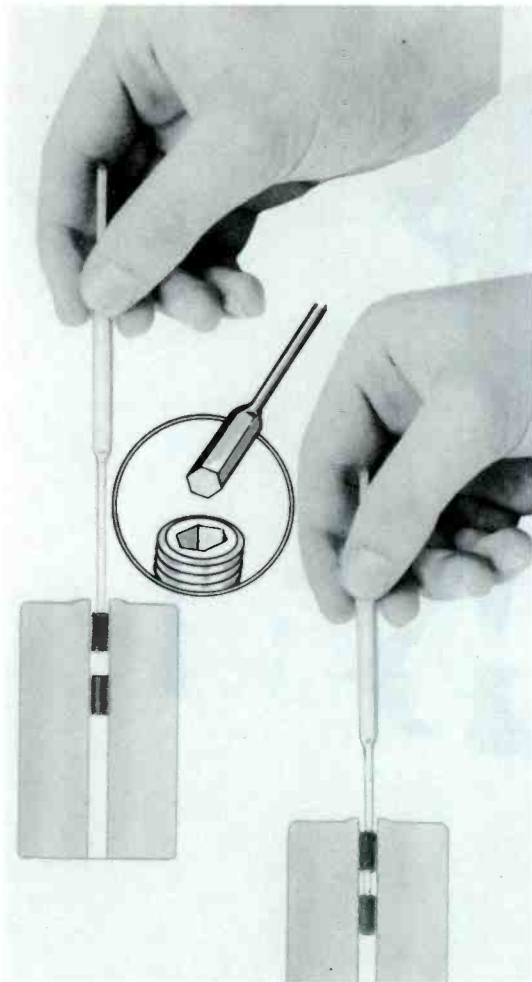

#### TIP FOR MILLED SCREW

The adjustment screw shown in the inset has a milled type head. The alignment tool is slotted to receive the tip of the screw. The milled type of screw can easily be damaged by pliers or by alignment tools which do not match the milled end.

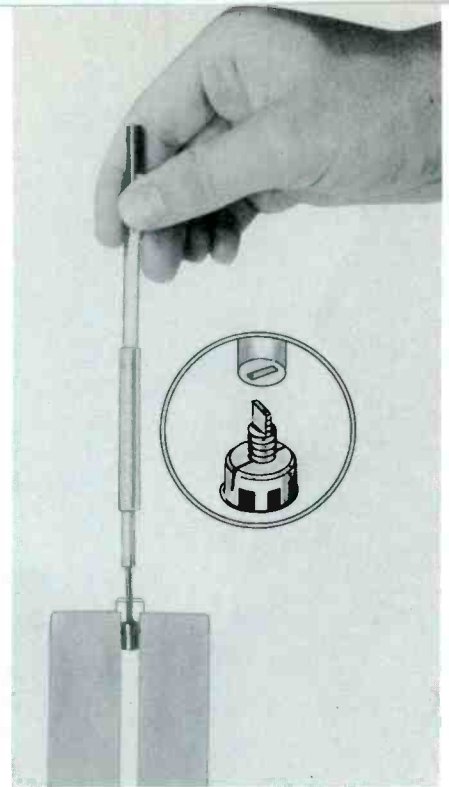

#### HEXAGONAL TIP

The hexagonal hollow opening through this powdered-iron core offers a unique feature—both cores of a transformer can be turned from one end. The hexagonal end of the alignment tool is first inserted into the hole in the nearest core, and this core is turned. The tip of the alignment tool can then be pushed on through this core, and the second core can be turned. The shaft between the hexagonal tip and the handle of the tool is made thin enough to turn freely inside the nearest core so that the adjustment of the latter will not be altered.

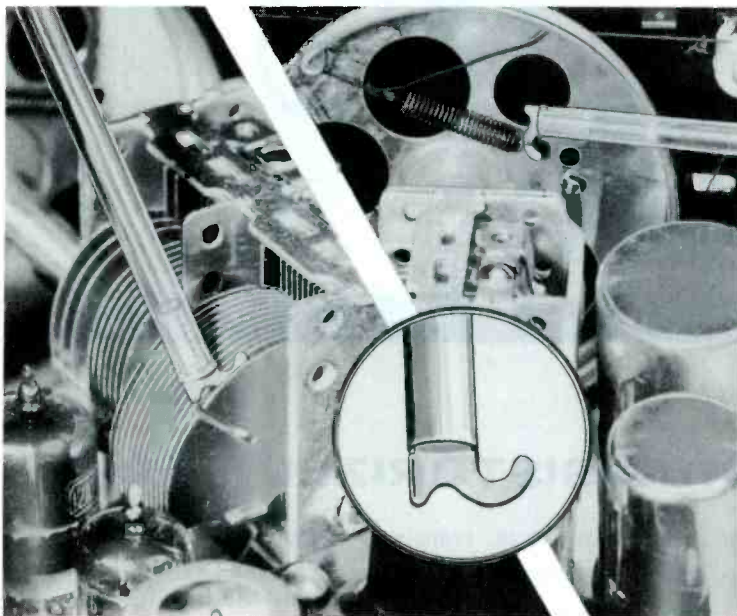

#### HOOKED TIP

The odd-shaped tip on the end of this insulated alignment rod has a number of applications in the service field. A dial-cord tuning system can be strung with the help of this tool. By means of the hook, the tension spring of the dial can be slipped into place over the catch inside the dial-cord drum.

The tip can also be used to bend the outside plates of tuning capacitors and to dress the leads in a receiver chassis.

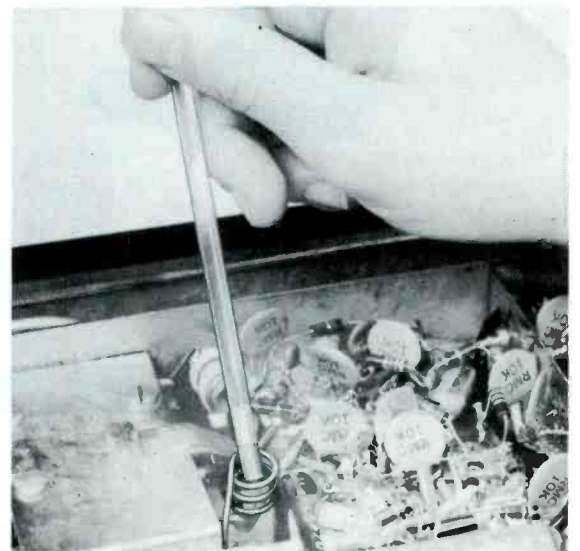

#### TUNING WAND

The tuning wand is a two-purpose tool designed to check the tuning of unshielded coils. It can be used in radio, television, FM, and all other phases of electronics work involving tuned coils. One end has a powdered-iron core; and the other end generally has a brass core or sometimes a copper core. When the iron tip is placed inside or close to the coil, the inductance of the coil is increased because the magnetic field is concentrated near the coil. The brass tip of the wand on the other hand, acts as a shorted secondary winding and reduces the inductance of the coil.

By observation of the effect which the tuning wand has on the signal, it is possible to find out whether or not the amount of inductance in the circuit is sufficient.



*Introducing the new champion . . .*

## **RCA BATTERIES FOR TRANSISTORIZED RADIOS**

Yes, the transistorized radio receiver is here to stay, and that means extra "transistor" battery business for you. Folks like the new transistorized receivers because of their compact size, perfect portability and economical use of battery power. They'll be taking these receivers everywhere. Be ready to fill "transistor" battery needs. Only a few battery types to stock to fill virtually all of your requirements; very little display space needed. In addition, RCA has a comprehensive line of batteries for all your portable needs. And remember, the famous RCA name on a battery means a battery practically pre-sold.



**RADIO BATTERIES**  
RADIO CORPORATION OF AMERICA



# ShopTalk

MILTON S. KIVER

Author of *How to Understand and Use TV Test Instruments* *Analyzing and Tracing TV Circuits*

## Power Transistors

In the preceding two issues in our columns, we discussed first the factors which tend to limit frequency response and second the various ways in which these restrictions were partially and sometimes totally circumvented in manufacture. This month, we are going to turn our attention to power transistors and to some of the difficulties which are encountered in the development of units capable of handling relatively large amounts of power.

The difficulties exist because of the heat which is generated by the passage of current through the transistor and because of the effects of that heat on the atomic bonds that form the lattice structure of the crystal. This is because the effectiveness of transistor action is largely dependent upon the condition of these electronic bonds and the number of free electrons or holes which are present. For example, when the transistor is made, the concentration of the added impurities must be carefully controlled. If we add too much impurity, the conductivity of the germanium will increase to such an extent that the ability of the emitter to control the current flowing to the collector will be seriously hampered and even totally destroyed.

Conductivity will also rise with temperature. An increase in thermal energy will enable more electrons to break away from the bonds that hold them to the various atoms. This will mean more free electrons and holes which, in turn, will lead to a greater current flow in both input (emitter-to-

base) and output (collector-to-base) circuits for the same applied voltages. Emitter control of collector current, a necessary condition of transistor action, will be seriously undermined. (In a vacuum tube, this is equivalent to a reduction in grid control over plate current.) It is even possible for the thermal action to feed on itself and eventually to destroy the transistor completely. The higher temperature results in more current which raises the temperature even higher, and this cycle is repeated until the entire unit is permanently damaged.

## Collector-Saturation Current

At this point, it might be well to make the acquaintance of a factor that has an important bearing on the power capabilities of transistors. (We will have occasion to refer to this factor again, in a subsequent column, when we develop several simple tests which every service technician can perform on transistors to determine whether they are good or bad.) The symbol  $I_{co}$  stands for the current that flows (under normal reverse-bias conditions) in the collector circuit when the emitter current is zero. This means that the collector has its normal reverse bias and that the emitter circuit is open. Under these circumstances, the current path must be between the base and collector. See Fig. 1.

Since the collector is reverse biased, we should expect no current at all to flow; but the  $I_{co}$  current is found, and there arises the question, "Where does it come from?" Because of the heat (or

thermal energy) which is always present, some electrons in the crystal structure gain enough energy to break their valence bonds. For every electron that brakes its bond, a positive charge (a hole) is created. (The structure is initially neutral in charge; hence, when an electron escapes from a bond, a counterbalancing positive charge remains in the broken bond and this represents the corresponding positive hole.) The electrons thus freed will be attracted to the positive terminal of the applied voltage, and the holes will be attracted to the negative terminal. The ensuing flow of electrons and holes is the current  $I_{co}$  previously indicated.

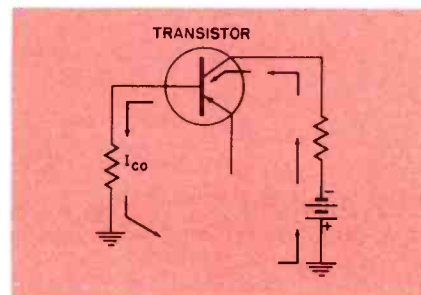

Fig. 1. The Current Path for  $I_{co}$ .

Since  $I_{co}$  is dependent on the available heat energy present, it will not be affected by the collector voltage. It will also not be affected by any emitter current that may flow if the emitter circuit were complete. In short,  $I_{co}$  may be considered as an independent current owing its existence largely to the heat energy available. (A small portion of  $I_{co}$  is contributed by leakage paths

Please turn to page 38

# EXPO PRESENTS

# I. R. I. S.\*

INFINITE REJECTION INTERFERENCE SYSTEM

the world's first fundamental and complete answer to the interference problem...

## \* The Sensational I.R.I.S.

gives infinite rejection of the interfering signal regardless of direction or channel or whether the interference is co-channel, adjacent channel or ghosts.

The rejection of the interfering signal is accomplished by opposing the interfering signal with a signal of equal amplitude but of opposite phase, thus producing complete cancellation. Simply rotate the upper section of the antenna to a position where the interference disappears.

Can be used either in a fixed installation or with rotor. All accessories and harness furnished for quick, easy installation.

### The Famous EXPO Antenna

is used in I.R.I.S. with its fundamental unlimited bandwidth characteristic, thus insuring excellent performance throughout the 82 channels.

No more Venetian blinds, or ghosts or distortion from an interfering co-channel signal or "splatter" from a strong local station.

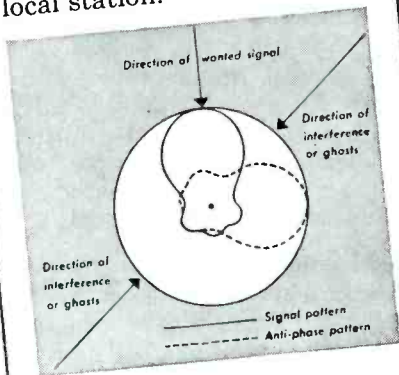

The combination of the principle of the exponential curve and the proved performance of I.R.I.S. offers an exceptional sales potential, both in antennas and TV sets. Now is the time to cash in on this exclusive opportunity.

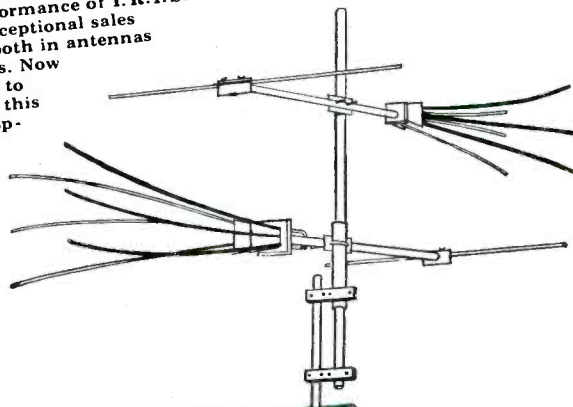

\*Pat. applied for

EXPO-I.R.I.S. comes in the following models:

- XO2R6 2-bay, 6 element EXPO-I.R.I.S. List \$20.95
- XO2R8 2-bay, 8 element EXPO-I.R.I.S. List \$25.50
- XO4CR6 4-bay, 6 element colinear EXPO-I.R.I.S. List \$53.25
- XO4CR8 4-bay, 8 element colinear EXPO-I.R.I.S. List \$61.75

**ORDER TODAY FROM YOUR DISTRIBUTOR**

whom we will supply until official distributors are designated in your locality.



**HOLLOWAY ELECTRONICS CORP.**  
Fort Lauderdale, Florida

In the Interest of . . .

# Quicker Servicing

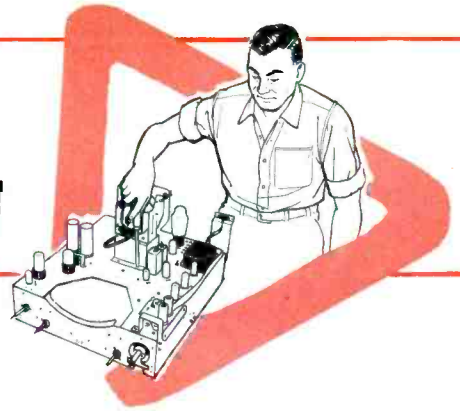

by Calvin C. Young, Jr.

## Hum Problems

Hum problems in radio and TV receivers are generally caused by failure of a filter component in the power supply or by heater-to-cathode leakage in a tube. In the first two examples which follow, however, the hum was caused by failure of ground connections.

### Hum in Picture

An intermittent hum had developed in the picture on a Philco TV receiver. The indications on the screen and in the sound were such that the trouble appeared to be caused by heater-to-cathode leakage in a tuner or video IF stage. Substitution of these tubes failed to remedy the trouble, and the receiver was therefore taken into the shop.

An oscilloscope analysis of the signal revealed that the signal output from the video detector was being modulated by a 60-cps signal. A high-impedance RF detector probe was used to check the output signal from the tuner. The 60-cps modulation was also present at this point, and therefore the B+ and AGC inputs to the tuner were checked with the oscilloscope.

The AGC line had a large 60-cps signal present on it. While the AGC network was being checked, the pilot light (a No. 47) was accidentally broken. Immediately the hum disappeared. The pilot light was replaced with a new one of the same size, and the hum reappeared immediately. Close examination of the circuit revealed that the ground returns of the AGC filter capacitor and the pilot light were connected to the same terminal. Consult the drawing in

Fig. 1. This terminal was fastened to the chassis with a rivet and was not making good contact. Soldering the ground terminal to the chassis remedied the trouble.

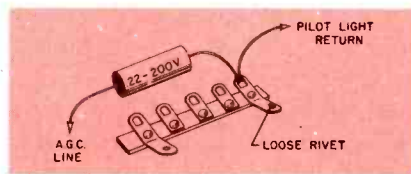

Fig. 1. Ground Returns for the AGC Filter Capacitor and the Pilot Light in the Philco TV Receiver.

Since some of the other ground terminals in this receiver were also riveted to the chassis, they were also soldered so that any future trouble from this source might be prevented.

### Hum in Sweep Systems

A case involving an Olympic TV receiver which seemed to have a combination of 60-cps and 120-cps modulation of the horizontal sweep was recently encountered. The technician first suspected the horizontal oscillator and output tubes; therefore, the

tubes were checked by the substitution process. This failed to eliminate the trouble, and the original tubes were reinstalled. Further investigation revealed that the trouble showed up in the raster only with a signal applied. After considering this fact carefully, the technician suspected that the trouble was caused by a defect in the horizontal AFC network.

The schematic diagram in Fig. 2 shows the horizontal AFC and oscillator circuits. A thorough resistance check in the horizontal AFC circuit revealed that the stabilizing capacitors C57 and C58 were not grounded. A close visual check of this network showed that these components were connected to the metal mounting ring of the tube socket. The hum was caused by the poor connection between the chassis and the mounting ring which was riveted to the chassis.

An accurate analysis of the symptoms simplified the problem of locating the cause of a trouble which otherwise might have been difficult to locate.

### Hum in Radio

A customer recently brought an AC/DC radio into the shop and complained that, after it had been in operation for 30 minutes, it began to have a hum which grew louder and louder as the radio played until the hum was louder than anything else. The technician suspected that a tube was causing the trouble, and all of the tubes were checked in a tube checker when the set was first received. All were good. The original tubes were reinstalled in the radio, and the radio was

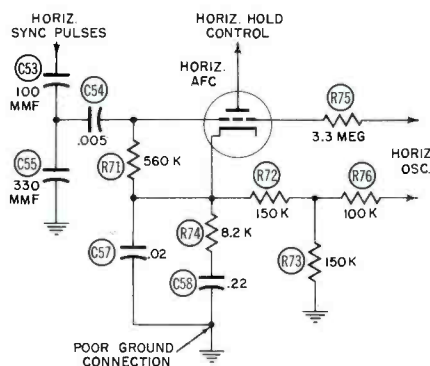
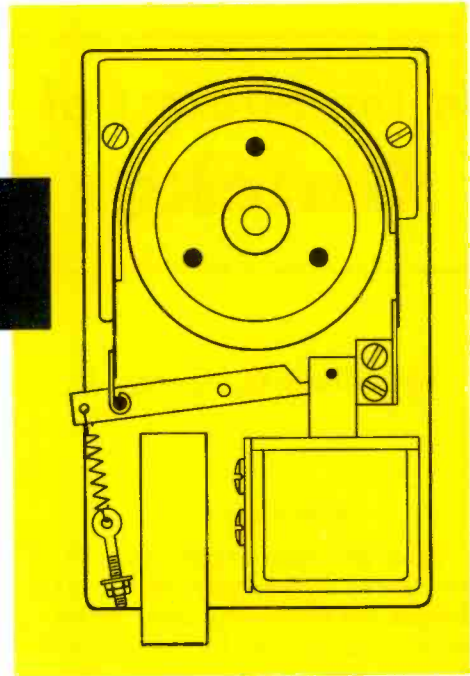

Fig. 2. Schematic Diagram of Horizontal AFC Network in Olympic TV Receiver.

• Please turn to page 80

# BRAKES and TAPE TENSION

The Tenth in a Series  
of Articles Devoted to  
the Principles of  
Magnetic Recording



by Robert B. Dunham

Proper adjustment and maintenance of tape recorders were stressed in the article "Maintenance of Tape Speed" in the December 1955 issue of the *PF REPORTER*. Most of the space in that article was used for a discussion of motors because of the significant part they play in maintaining correct tape speed. No one can deny the importance of constant tape speed because movement of the tape at a uniform rate of speed across the faces of the heads is one of the very basic requirements of a satisfactory tape recorder.

Motors are critical items in a tape recorder because they move the tape, but other things such as brakes and proper tape tension are also very important. The tape must be moved at a constant speed while the recorder is operating in the record or playback modes; but in addition, the tape must be handled properly in all of the operating modes. The tape must be started, stopped, unwound, and rewound without being broken, stretched, or otherwise damaged.

To begin with, the tape-transport mechanism must be designed to handle the tape in the proper manner; and then it must be adjusted and maintained in the correct operating condition.

## TAPE TENSION

The correct amount of tension must be applied to the tape at all times. Undesirable variations in

both frequency and amplitude will be present in the recorded or played-back signal if the tension on the tape varies while the signal is being recorded or played back.

Different tape tensions are used in different operating modes. When a recorder is operating in the fast-forward or rewind modes, the tape is not held against the faces of the heads; but enough tension must be maintained on the tape so that it will unwind evenly from one reel and will wind smoothly on the other. Unnecessary wear on the tape will result if excessive tension is applied. On the other hand, the tape may at times become very slack, throw loops, or move in some other erratic manner if insufficient tension is maintained on the tape.

When the tape-transport mechanism is started or stopped in any operating mode, the tape tension must be controlled so that the tape will not be broken, stretched, or otherwise damaged when the brakes are applied or released.

Tape tension is obtained and controlled in several ways. Motor torque, brakes, and tension arms or levers are usually combined to obtain the desired amount. In recorders that employ separate motors to turn the supply and take-up reels, the torques of the motors are usually utilized to supply at least part of the tape tension during all operating modes. The mo-

tors driving the supply and take-up reels normally turn the reels in opposite directions. Tape tension can be applied by the operation of the motors at different torques. For example, when the recorder is operating in the playback mode, the take-up reel will be driven in a counterclockwise direction by its motor. The tape will unwind from the supply reel in a counterclockwise direction, but the motor for the supply reel will try to turn the reel in a clockwise direction. In this way, the supply-reel motor with its reduced torque applies a drag or tension on the tape.

Torque is usually reduced by insertion of the proper amount of resistance in the motor circuit. In the Magnecord M80 tape recorder, the two large resistors indicated in Fig. 1 are employed to obtain correct amounts of operating torque. Torque adjustments in this recorder are made by moving the adjustable taps on the resistors. Operating torques can be measured with a small spring scale attached to a length of string around the hub of the appropriate tape reel, as shown in Fig. 2. If the spring scale is pulled in the direction of the arrow while the machine is running in the record or playback mode, the amount of torque can be read on the scale. The inch-ounces of torque can be obtained by multiplying the number of ounces on the scale by the

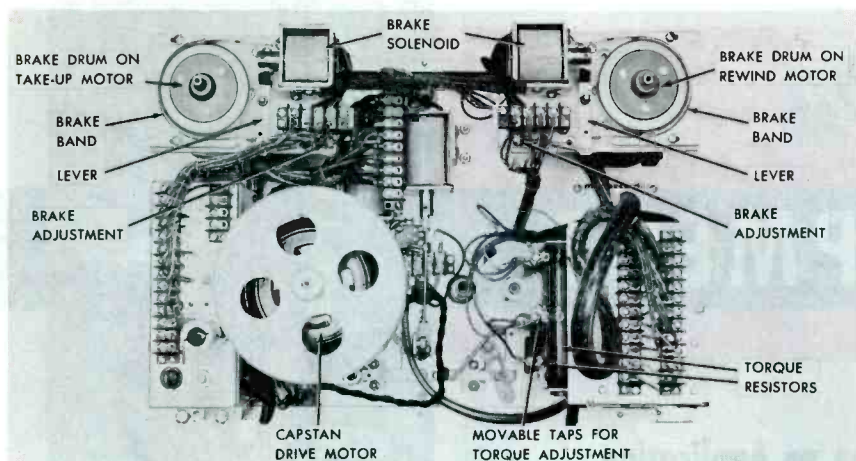

Fig. 1. Bottom View of Tape-Transport Section of Magnecord Model M80 Tape Recorder.

number of inches of the radius ( $R$  in Fig. 2) of the reel hub. In the Magnecord Model M80 recorder, the operating take-up torque should read 12 to 16 inch-ounces and the operating supply torque should read 4 to 6 inch-ounces.

The amount of torque, the method by which it is obtained, and the way it is measured vary in different recorders; therefore, it is necessary to consult authoritative service literature when tests and adjustments have to be made. The examples that we give here can at least give some idea of what can be expected.

Recorders that use only one motor to drive the take-up and supply reels and the capstan usually make use of various types of selective clutches or brakes to obtain tape tension. Selective clutches are arranged to produce a drag (when necessary) on either one of the reels when it is turned in the direction that requires tension to be applied on the tape. One such system was described in the article "Transport Mechanism in

Ampex Model 600 Tape Recorder" which appeared in the August 1955 issue of the *PF REPORTER*. A mechanical arrangement of selective brakes and felt-loaded

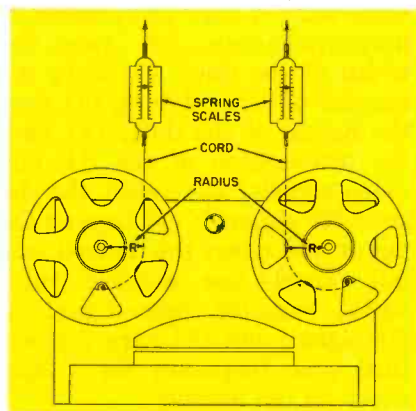

Fig. 2. Spring Scale Used to Measure Operating Torque.

clutches control the tape tension during all modes of operation of the Model 600.

### BRAKES

Brakes of some type are used to control and stop the reels on

all tape recorders. These brakes are often utilized in maintaining proper tape tension, but their primary purpose is to provide proper braking action when the mechanism is stopped in any mode of operation.

Brakes can be mechanical, dynamic, magnetic, or a combination of any of these types. No matter what type of brakes are used, they must operate in the correct sequence and provide a smooth and positive stopping of the tape. It is not difficult to recognize the necessity of having the supply reel and the take-up reel stop at the same instant because, if they do not, the tape can be stretched or broken; or it can become tangled if it continues to unwind off one reel after the other reel has stopped. The brakes are very likely suspects if the tape spills or breaks when the tape-transport mechanism is stopped.

### Mechanical Brakes

The brakes on the Concertone Model 1502, shown in Fig. 3, are an example of the mechanical type. Brake shoes faced with felt and mounted on pivoted arms press against the brake drums on the spindles of the take-up and supply motors and stop the reels. Adjustments are made by means of the collars and arms indicated in Fig. 3.

Mechanical brakes are also used on the Magnecord Model M80 shown in Fig. 1. Their action is controlled by relays and solenoids. The brake bands make contact with the brake drums on the shafts of the rewind and take-up motors. The bands are lined with felt and normally remain in contact with the drums when the solenoids are not energized. When the recorder is started in one of its operating modes, appropriate switches are closed and relays are actuated to energize the solenoids and release the brakes.

Brake torque may be checked by using the spring scale shown in Fig. 2. The checks are made with the power off, and each brake should measure 38 to 40 inch-ounces. Adjustments are made by turning the nuts indicated in Fig. 1 and by positioning the solenoid on its mounting bracket.

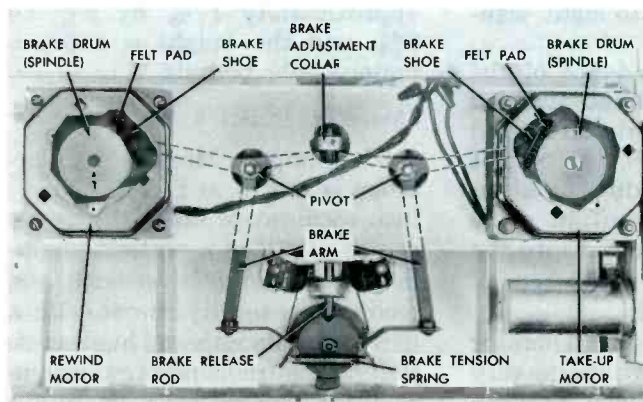

Fig. 3. Brakes Used in Concertone Model 1502 Tape Recorder.

• Please turn to page 49

# Notes On

# TEST EQUIPMENT

## Presenting Information on Application, Maintenance, and Adaptability of Service Instruments

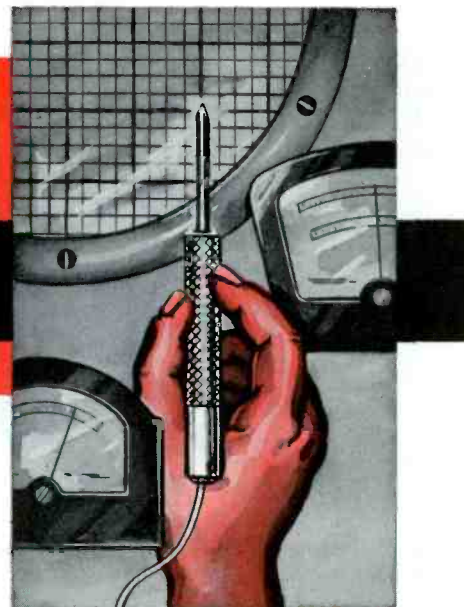

by Paul C. Smith



Fig. 1. The Simpson Model 434 Varidot White-Dot Generator.

### Simpson Model 434 Varidot White-Dot Generator

The Simpson Model 434 Varidot white-dot generator is designed to provide white dots for use in making convergence adjustments of color receivers and for checking many properties of color and monochrome TV receivers. Among these properties are sweep linearity, frequency response of the receiver, hum in the picture, and synchronization range.

The signal is provided as a positive or negative video signal with a maximum amplitude of 3.5 volts peak to peak or as a modulated RF signal with a maximum amplitude of 50,000 microvolts. The RF signal is modulated 90 per cent and can be on any channel from 2 through 6.

The general appearance of this instrument can be seen in Fig. 1.

The eight front-panel controls serve to: (1) vary the number of horizontal dots; (2) vary the width of the dots; (3) vary the number of vertical dots; (4) vary the height of the dots; (5) vary the attenuation of the RF and video signals; (6) select the desired RF channel; (7) turn on the power and select the desired output signal—the positive video signal, negative video signal, or RF signal; and (8) vary the vertical sync frequency for a hum check on the receiver.

All of the adjustments for the size and number of dots are independent of each other. The vertical dot number is variable from 6 to 15, and the horizontal dot number is variable from 6 to 14. Dot width is variable from approximately .06 to .5 inch on a properly adjusted 21-inch receiver. The dot height obtained with the video output signal can be varied from approximately one to eight scanning lines.

The output impedance of the instrument is 300 ohms, balanced to ground for RF and unbalanced for the video signal. One output cable serves double duty as either an RF or a video output cable merely by being plugged into the proper output jack at the rear of the instrument.

The Model 434 dot generator provides a dot pattern that is very stable, and the dots will be sharp

and distinct on a receiver of adequate bandwidth. This fact makes the instrument useful for checking the bandpass of a receiver. The provision for varying the dot width is a feature that will enable the operator to check the point at which the frequency response of the receiver falls off.

Another interesting feature is the provision for making hum checks of receivers. Hum in a receiver can be made apparent by adjustment of the HUM CHECK control of the instrument to a point where the vertical sync frequency is slightly different from the power-line frequency. Hum will be indicated by a tendency toward horizontal pulling and unstable synchronization. An indication of the synchronization pull-in range of the receiver can also be obtained when the hum is being checked.

The size of the instrument is approximately 11 $\frac{3}{8}$  by 8 $\frac{1}{4}$  by 8 $\frac{3}{4}$ , and the weight is approximately 11 $\frac{1}{2}$  pounds.

### Simpson Model 458 Colorscope

The Simpson Model 458 Colorscope is shown in Fig. 2. This 7-inch oscilloscope offers the user a choice of either a vertical amplifier with a wide bandwidth and medium sensitivity or one with a narrow bandwidth and high sensitivity. The frequency response in wide-band operation is flat within

$\pm 2$  decibels from 10 cycles to 5 megacycles per second and flat within  $\pm 1$  decibel from 20 cycles to 4.5 megacycles. The frequency response in narrow-band operation is flat within  $\pm 2$  decibels from 10 cycles to 300 kilocycles per second and flat within  $\pm 1$  decibel from 20 cycles to 200 kilocycles.



Fig. 2. The Simpson Model 458 Colorscope.

The vertical deflection sensitivity in wide-band operation is 40 millivolts rms per inch; and in narrow-band operation, it is 15 millivolts rms per inch.

The frequency response of the horizontal amplifier is flat within  $\pm 2$  decibels from 10 cycles to 300 kilocycles per second and flat within  $\pm 1$  decibel from 20 cycles to 200 kilocycles per second. The horizontal deflection sensitivity is 115 millivolts rms per inch in the high-sensitivity position of the function switch and 1.4 volts rms per inch in the low-sensitivity position. The step attenuators in the vertical amplifier are frequency compensated. The rise time of the vertical amplifier is less than 0.05 microsecond in the wide-band position.

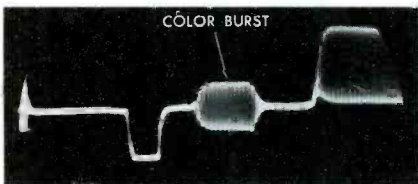

Fig. 3. Response of the Simpson Colorscope to a Color Signal.

The response of the vertical amplifier in the wide-band position is such that the 3.58-mc color-subcarrier burst in a color signal

can be viewed with 100-per-cent response. Fig. 3 is a direct photograph of the response of the Colorscope to a color signal from a generator. The color burst can be seen in the figure.

The 7-inch screen is fitted with a green filter for increased contrast in viewing. Horizontal and vertical reference lines are ruled on the screen for calibration purposes.

The internal sweep generator is of the multivibrator type and provides a range of sweep frequencies from 14 cycles to 250 kilocycles per second. This range of frequencies is covered by four overlapping steps of the coarse-frequency switch. A fine-frequency control is provided for varying the sweep frequency within the range of any particular setting of the switch.

Provisions are made for four types of synchronization: (1) an external signal can be applied to the EXT. SYNC. jack, (2) a signal of positive polarity can be applied internally from the vertical amplifier, (3) one of negative polarity can be applied internally from the vertical amplifier, and (4) a signal at line frequency can be applied internally.

Other front-panel jacks, besides the EXT. SYNC. jack already mentioned, are as follows: two ground jacks, one on each side of the instrument; a vertical input connector for the shielded cable supplied with the instrument; a jack for a sawtooth output signal; a jack for intensity modulation; a jack for obtaining an 18-volt peak-to-peak signal from the instrument for calibration purposes; and a jack for applying an external sweep signal to the horizontal amplifier.

Size of the Colorscope is 11 by 17 $\frac{1}{4}$  by 13 $\frac{5}{8}$  inches, and the weight is 27 pounds and 9 ounces.

A low-capacitance probe (Simpson Model 741) is available as an accessory and provides an input impedance of 10 megohms shunted by 14 micromicrofarads.

#### The Low-Capacitance Probe

The low-capacitance probe is often used with oscilloscopes when it is desired to view waveforms of high frequencies in high-

impedance circuits. Its use will give a more faithful representation of the signal present than would the use of a simple shielded lead to the input of the oscilloscope. Normally, the oscilloscope has an input circuit of fairly high impedance; but under certain circumstances, it may load the circuit under test to such an extent that the waveform seen may be somewhat distorted.

Some places where a low-capacitance probe can be used to advantage are high-impedance circuits in which video signals or horizontal sync signals are present. These signals contain frequencies high enough to be attenuated or changed by small shunt capacitances.

Most present-day oscilloscopes have input attenuators that are frequency compensated for the most accurate waveform presentation. This feature was discussed in the April 1955 issue of the *PF REPORTER*, pages 67 and 68. A

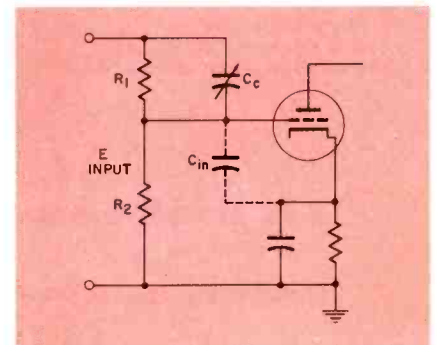

Fig. 4. Input Circuit in an Oscilloscope Having a Frequency-Compensated Attenuator.

simple input circuit with compensating capacitance is shown in Fig. 4.  $R_2$  is the grid resistor in the input circuit, and  $R_1$  is in one section of the step attenuator.  $C_{in}$  is the grid-to-cathode capacitance of the input tube. Stray wiring capacitances between grid and ground can also be considered as lumped together with this capacitance, and their combined effect is to bypass the higher frequencies to ground more readily than they bypass the lower frequencies. Without the compensating capacity  $C_c$ , this unbalance would result in frequency distortion of the waveform.

• Please turn to page 52



### NEW CHASSIS PUNCHES

A complete line of precision punches, featuring Walsco-Pioneer "Taper Wedge" design to speed more accurate hole punching... any size, any shape.



### CHEMICALS

A complete line of chemical specialties, including cements, solvents, and contact cleaners in bottles and handy spray cans.



### HARDWARE & SERVICE AIDS

A complete line of essential small component hardware, packaged in reusable plastic boxes. Dial cord, feed-thru bushing, and other valuable service aids.



### NEW TEKNI-LABELS

A complete line of handy title and design decals for speedy labeling of electronic equipment.

### NEW PHONO-RECORDER DRIVES & BELTS

The first, complete line of vital replacements for all major phonographs and tape recorders. Packaged in convenient kits or sold separately.

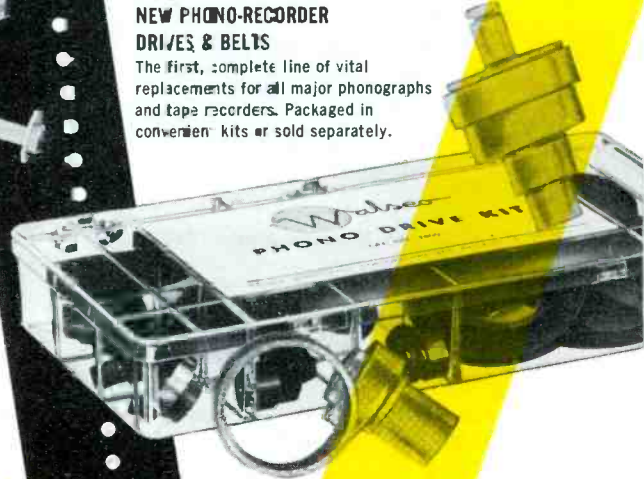

**If it makes servicing  
faster, easier,  
more profitable...  
you'll find it in the**

**COMPLETE WALSCO LINE**

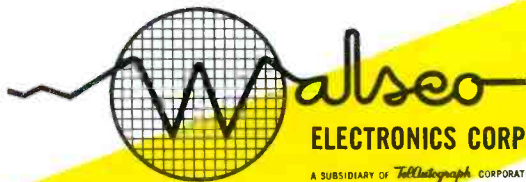
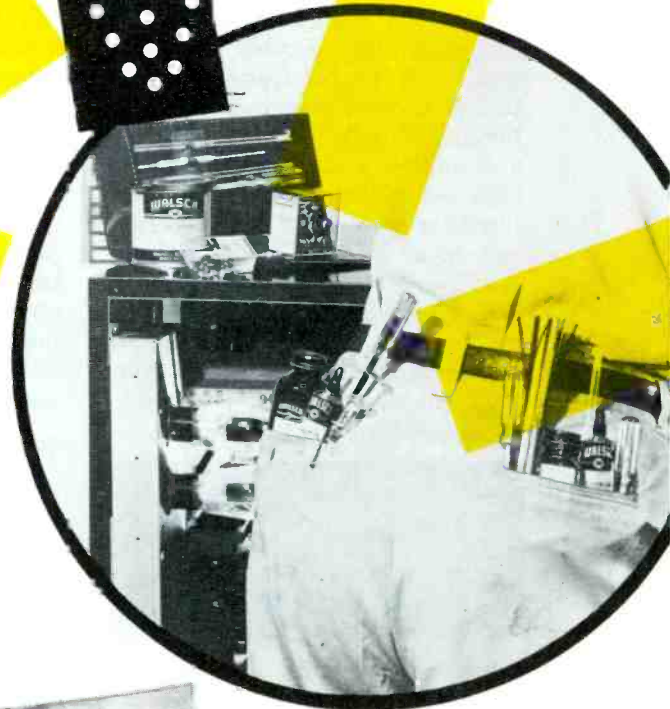

**ELECTRONICS CORPORATION**

A SUBSIDIARY OF *Tellatograph* CORPORATION

3602 Crenshaw Blvd.  
Los Angeles 16, Calif.

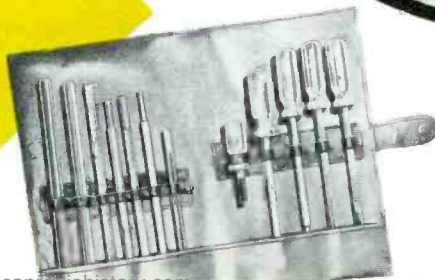

### ALIGNMENT TOOLS

A complete line of tools for every servicing job.



# Examining DESIGN Features

## Book Radio

The portable radio pictured in the heading has its outer case styled to represent a conventional book cover. This unit is the Crosley Model JM-8WE battery-operated AM radio receiver. The particular model shown features a white leatherette cover with a gold inscription identifying it as the well-known novel *Treasure Island*. The edges of the case are fashioned to resemble the edges of book pages, and this also adds a great deal to the unique disguise of the radio. The actual over-all size of the unit is about 7 inches long, 4½ inches wide, and 1⅞ inches thick.

The on-off switch is activated by the opening and closing of the front cover, and the two manual control knobs visible in the photograph are for station tuning and volume control. Three subminiature tubes and two transistors make up the principal stages of this receiver. A 1V6 tube is employed in the converter stage, a 1AH4 tube serves as the IF amplifier, and a 1AJ5 tube functions as the detector and audio amplifier. The two RCA transistors of the 2N109 type are connected in a push-pull audio output stage which drives a 2¾-inch speaker.

The receiver chassis, with batteries removed, can be seen in the illustration of Fig. 1. The chassis may be removed from its booklike case by removal of the slotted-head screw located in the center of

by Leslie D. Deane

the front panel. If the receiver is held face down, the case can then be lifted off the panel. The majority of components are placed on a small printed-wiring board which is approximately 5¼ inches in length and only 1⅜ inches wide. In order to conserve over-all space, the manufacturer has mounted the resistors and capacitors on end with their leads extending through the board.

The two 455-kc IF transformers, an interstage transformer, and the audio output transformer employed in this receiver are of miniature varieties and therefore account for its compact design. Power is supplied to the unit by one 4-volt mercury A battery together with a 45-volt B battery. The manufacturer recommends that the original types of batteries be used when replacement becomes necessary. If a B battery having a metal

case is selected for use in this receiver, it must be installed to prevent shorting of the terminals on the volume control or these terminals must be bent so that they will not come in contact with the metal case. An A battery which is slightly shorter in length than the original type may be used as a replacement provided that the battery bracket is bent or reshaped to ensure proper contact with the battery terminals.

Should it become necessary to replace the 1AH4 tube, it is essential that the metal covering of the tube be insulated with the original vinyl sleeve. The metal covering is connected to the filament of the tube and could cause a possible short if not protected. The two transistors employed in this receiver are matched for a balanced output; therefore, if an equivalent type and not an exact replacement is used, both units should be replaced at the same time.

It has been found that a few of the receivers in this Crosley series may have a tendency toward oscillation at the low end of their tuning range. This condition may result from the fact that the initial battery voltage may be too high and may cause the receiver to become extremely sensitive and to overload. The manufacturer recommends two possible ways to correct this difficulty. In some pro-

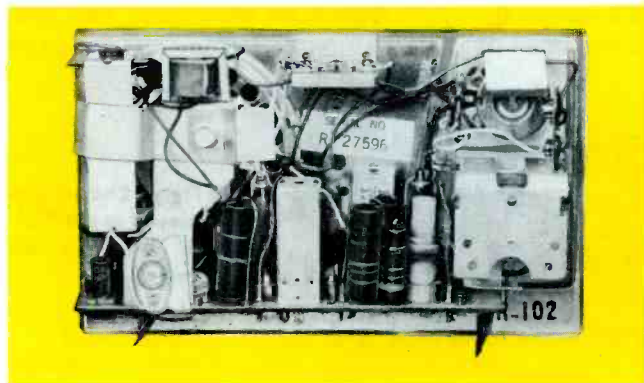

Fig. 1. Chassis View of the Crosley Model JM-8WE Book Radio.

duction runs, a small shield has been placed on the bottom side of the printed-wiring board under the second IF transformer. In these receivers, the oscillation can be reduced if the shield is unsoldered and moved nearer to the board where it should be resoldered into position.

The receiver also has an 8.2-megohm resistor which is connected between the positive terminal of the A battery and the AVC line. This resistor applies a slight positive voltage, which would normally oppose the AVC voltage, to the grid of the converter stage and thus increases the sensitivity of the receiver. In order to reduce the sensitivity and to eliminate a possible cause of oscillation, it may be necessary to remove this bias resistor from the AVC line.

Because of the compact design, it may be necessary to remove the printed-wiring board from the front panel in order to reach components on top of the board. This is accomplished by removal of two 1/4-inch screws with hexagonal heads from the speaker magnet frame and one from the mounting bracket of the tuning capacitor. The chassis can then be tilted away from the panel—the movement is limited only by a few connecting leads.

#### Cosmetic-Bag Radio

Another rather novel design in portable radio cabinets is reflected in the Philco Model D-665 shown in Fig. 2. This unit is a four-tube AM radio receiver housed in an attractive portable carrying case. The case design resembles a cosmetic or overnight bag and comes equipped with a mirror covering the inside surface of the lid and a roomy utility compartment directly in back of the radio enclosure. The compartment is very handy for carrying small objects that may be needed when traveling or when outdoors.

This portable receiver may be operated on its self-contained batteries or on 117 volts AC/DC. To operate the unit on batteries, open the front part of the cabinet and insert the power plug into the slots provided in the change-over switch. This switch is located at the lower left-hand corner of the

vertically mounted chassis. The extra length of cord may be folded and stored in the space directly beneath the switch. In order to operate the receiver from a 117-volt AC or DC supply, the power plug must be removed from the change-over switch. This will automatically disconnect the batteries. Then insert the plug into a 117-volt socket.

The photograph of Fig. 3 reveals the chassis which is employed in this receiver. The speaker, with audio output transformer, is mounted separately in the cabinet and is not shown in Fig. 3. The chassis components are neatly



Fig. 2. Philco Model D-665 Portable Radio.

arranged on a printed-wiring board with ample space between parts. This affords adequate ventilation and makes servicing that much easier. The electrical design of the chassis is relatively conventional. The tube complement consists of a 1R5 converter; a 1U4 IF amplifier; a 1U5 detector, AVC, and AF amplifier; and a 3V4 audio output tube.

Rectification for 117-volt AC operation is accomplished by one selenium rectifier which carries approximately 68 milliamperes of

current during normal operation. This type of rectifier is designed especially for use on printed-wiring boards. The springlike terminal contacts are constructed for easy insertion into the board and will hold the unit in position prior to the soldering process.

The batteries employed in this receiver consist of a 75-volt B battery and two 1 1/2-volt A batteries. During normal battery operation, the B battery delivers approximately 10 milliamperes of current and the A batteries deliver about 130 milliamperes. The batteries can be installed in the radio by separating the two halves of the case. These are hinged at the bottom.

#### Highway Hi-Fi

A record enthusiast today need not confine his hi-fi activities to the home alone, for now it is possible to enjoy a number of recorded selections while traveling in a car. A practical auto record player has recently been developed by CBS-Columbia in co-operation with the Chrysler Corporation for use in the new 1956 Chrysler line of automobiles. The new accessory item sells for about eighty dollars and comes complete with six records. One of these mobile record players, known as the "Highway Hi-Fi" model can be seen in the photograph of Fig. 4.

The record player mounts under the dashboard directly beneath the radio where it is in easy reach for any occupant of the front seat. The unit plays through the car radio which has been designed to accommodate a phono input.

Records used with this player are of a special variety and are referred to as XLP records. These extra-long-playing records are seven inches in diameter and give up to 45 minutes of music or one hour of speech on each side. The new

• Please turn to page 78

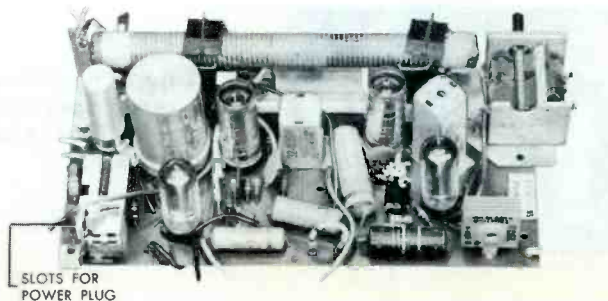
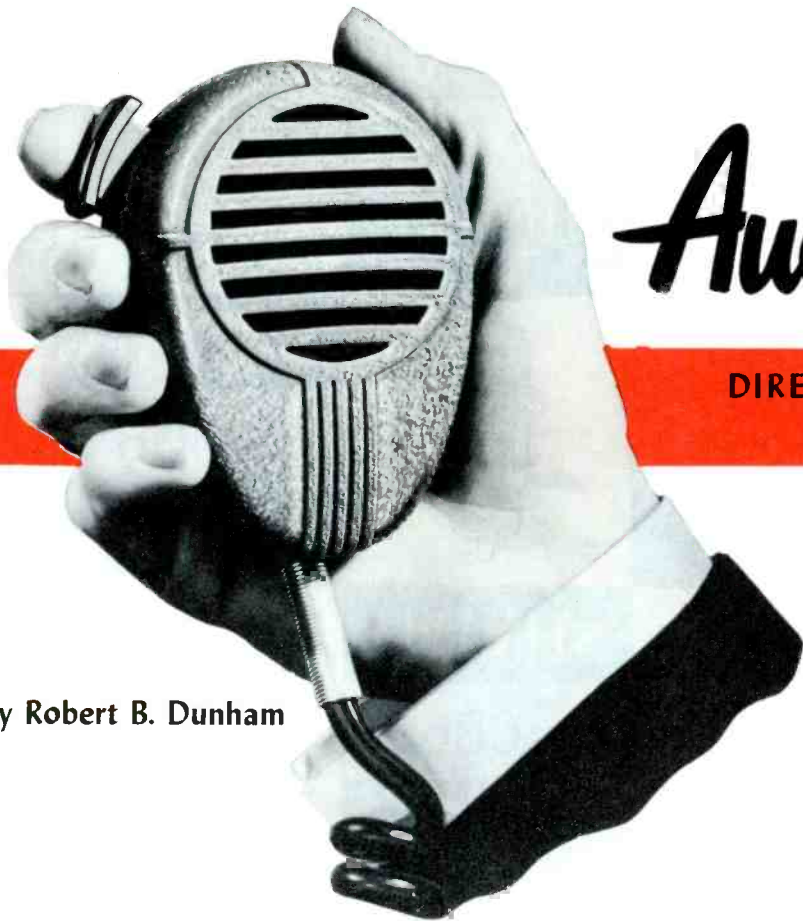

Fig. 3. Chassis Employed in the Philco Model D-665 Radio.



# Audio-Facts

## DIRECTIONAL CHARACTERISTICS of MICROPHONES

by Robert B. Dunham

In a previous column which served as an introduction to the general subject of microphones, we discussed some of the types that have been or are still in use. These types (carbon, crystal, dynamic, condenser, and ribbon) can be designed and constructed to possess a variety of characteristics. While a few of these characteristics are natural to certain basic types of microphones, it is interesting to find that most types can be designed to feature any of the important characteristics desired. Because of this we may find, for example, that one crystal microphone may bear no resemblance whatever to another crystal microphone because they have been designed for different purposes and differ in physical construction.

Many of these operating characteristics are so important that they determine just how successfully a chosen microphone can be used in some specific application. A discussion of what these characteristics are, how they are obtained, and why they are so important can prove to be both worth while and interesting.

The rated sensitivity of a microphone is usually given careful consideration before the microphone is selected for some particular application. It seems logical that the user should be interested in how much electrical signal will be developed by the microphone for the amount of acoustical signal picked up. He will be concerned if for no other reason than that he wants to know what equipment will be required with the microphone to obtain satisfactory results.

In addition to being interested in the sensitivity of a microphone, the user should also be very much interested in knowing whether the microphone will pick up sounds equally well from all directions or if it will be selective and pick up sounds from only one or two directions. The way in which a microphone will operate in this respect depends upon its directional characteristics which are so important that they are usually included in the description or data given about any microphone.

Microphones are often classed according to their directional

characteristics. The following discussion will cover some of the most commonly used classifications with a brief explanation of each one, although the terms in themselves are very descriptive.

### **Nondirectional, Omnidirectional, and Polydirectional**

These names all mean the same thing when applied to the directional characteristics of microphones. The ones which possess these characteristics pick up sounds equally well from all directions, although some units are slightly directional when picking up extreme high-frequency sounds. It is fairly obvious that nondirectional microphones are suitable for use in situations in which the user wishes to pick up all of the sound developed in the vicinity of the microphone.







### **Semidirectional**

Semidirectional microphones are basically nondirectional but become progressively more directional as the frequency of the signal being picked up increases. Most basic or simple microphones of all types fall in the semidirectional class; consequently, most types of microphones have to be modified before they will exhibit special directional characteristics.

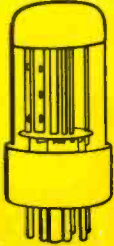
### **Bidirectional**

Bidirectional microphones, as the term implies, are sensitive to sounds coming from two directions. Microphones with this directional characteristic pick up

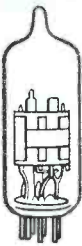
• Please turn to page 55

<p><b>SYLVANIA</b></p> <p>6SN7GTB</p> <p><b>ELECTRONIC TUBE</b></p>		<p><b>SYLVANIA</b></p> <p>6AU6</p> <p><b>ELECTRONIC TUBE</b></p>	
	<p><b>SYLVANIA</b></p> <p>6BQ6GTA</p> <p><b>ELECTRONIC TUBE</b></p>		<p><b>SYLVANIA</b></p> <p>5U4GB</p> <p><b>ELECTRONIC TUBE</b></p>
<p>NIA</p> <p>GT</p> <p>NIC</p>		<p><b>SYLVANIA</b></p> <p>6CB6</p> <p><b>ELECTRONIC TUBE</b></p>	
	<p><b>SYLVANIA</b></p> <p>1B3GT</p> <p><b>ELECTRONIC TUBE</b></p>		

## How to get the jump on call-backs in **6** easy moves

Here are six tube types called for most in your daily service work. Eliminate the call-backs from these types and your biggest share of headaches is over. It's easy to do just that, too, simply by getting into the habit of using only Sylvania tubes . . . in the familiar yellow and black carton.

These 6 types alone incorporate over 14 design and production improvements to eliminate the most common causes for "quick failures" and costly call-backs. It's no wonder more and more servicemen consider the yellow and black carton their "calling card of top quality service."

 **SYLVANIA**<sup>®</sup>

SYLVANIA ELECTRIC PRODUCTS INC.  
1740 Broadway, New York 19, N. Y.  
In Canada: Sylvania Electric (Canada) Ltd.  
University Tower Building, Montreal

LIGHTING • RADIO • ELECTRONICS • TELEVISION • ATOMIC ENERGY

# Time Constants



## The Significance of T-RC in Sync Circuits

by Verne M. Ray

The time constant of a circuit is an important factor in the determination of the effects the circuit will have upon various signals. Although he may not always be aware of it, the television technician deals with time constants in the normal course of servicing receivers. Among other uses, the

circuit is the product of the value of resistance in ohms times the value of capacitance in farads. For example, Fig. 1 shows a capacitor having a value of .01 microfarad connected in series with a 10K-ohm resistor. The time constant  $T$  of this circuit is:

$$T = RC$$

$$T = (10 \times 10^3) (.01 \times 10^{-6})$$

$$= .0001 \text{ second,}$$

$$= 100 \text{ microseconds,}$$

where

$R$  = resistance in ohms,  
 $C$  = capacitance in farads.

be charged to a potential of 99.33 volts. It would be considered that after 600 microseconds the capacitor is fully charged, and therefore the current is no longer flowing in the circuit.

If the rotor arm of the switch were then grounded as it would be in position 2, the rate of capacitor discharge would be the same as the rate of charge. In other words, the same amount of current would flow during the first 100 microseconds of discharge as during the first 100 microseconds of charge; and the time needed for the capacitor to discharge completely would be the same as the time needed for it to charge completely.

If the voltage rise across the capacitor during charge time were recorded graphically, an exponential curve like that labeled A in Fig. 2 would be obtained. Curve B shows that voltage decreases exponentially during discharge time. During either charge or discharge time, the current flow through the resistor in the circuit starts at a high value and decreases in accordance with curve

• Please turn to page 67

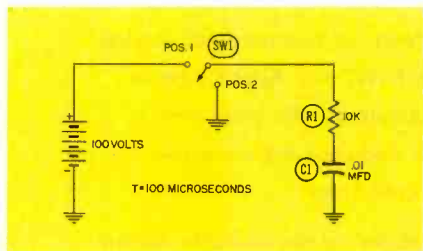

Fig. 1. An RC Circuit in Which C1 Can Be Charged and Discharged by Changing the Position of the Switch.

time-constant principle is utilized in AGC, sync, sweep, and high-voltage circuits. In this article, the utilization of this principle in sync circuits will be discussed.

The term *time constant* is used to define the rate at which a capacitor in an RC circuit will charge or discharge. The time constant, in seconds, of any RC cir-

Let us suppose that we are able to measure the voltage across the capacitor at any instant in a circuit like that shown in Fig. 1. It would be found that 100 microseconds after the rotor arm of the switch is moved to position 1, the potential across the capacitor would equal 63.2 per cent of the supply voltage or would be 63.2 volts. After a lapse of 200 microseconds, the voltage across the capacitor would be approximately 87 volts; and at the end of 500 microseconds, the capacitor would

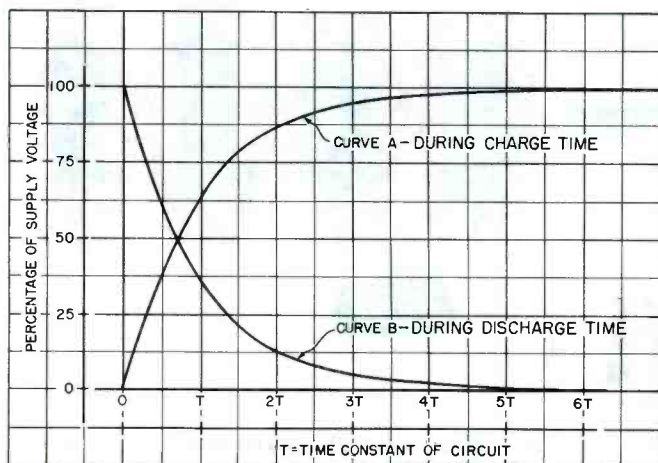
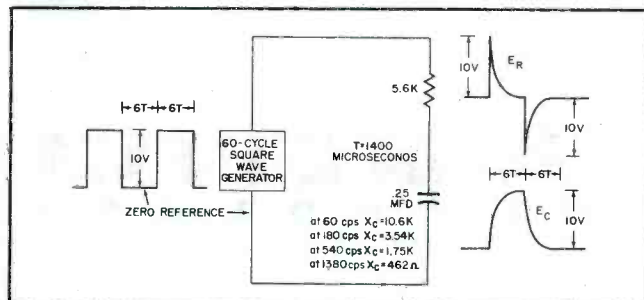

Fig. 2. Graphical Representation of Voltage Waveforms Across a Capacitor in an RC Circuit.

Fig. 3. An RC Circuit in Which the Duration of the Applied Voltage Equals  $6T$ .



# *I've Heard* **ENOUGH** *Claims...*



**-only "Staminized" Astron Capacitors really deliver better performance.**

Astron's capacitor "know-how" insures better performance 3 important ways — better designs, better materials, better production techniques — the secret of "Staminizing".

Learn the facts, as thousands of service technicians have, why Astron's extra-rugged capacitors build consumer satisfaction and repeat business — *eliminates callbacks!*

You'll find there's a dependable Astron *exact replacement* capacitor for every radio and TV requirement — **write for FREE "Astron Replacement Catalog AC-4D"**.

Ask your jobber for "Staminized" Astron Capacitors — today!

**PROVED BEST IN SERVICE!**



**ASTRON**  
CORPORATION  
255 GRANT AVENUE EAST NEWARK, N. J.



WEST COAST WAREHOUSE: 9041 WEST PICO BLVD., LOS ANGELES EXPORT DIVISION: ROCKE INTERNATIONAL CORP., 13 EAST 40TH ST., N. Y., N. Y.  
IN CANADA: CHARLES W. POINTON, 6 ALCINA AVE., TORONTO, ONTARIO

# Chemical Aids to Servicing

by THOMAS A. LESH

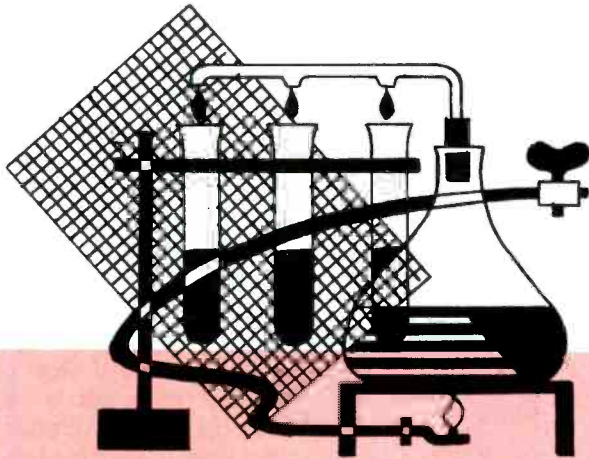

A variety of liquid chemicals are available and useful to the service technician. Some of them simplify the cleaning of switch contacts and the prevention of arcing in electronic equipment. Since these chemicals help the technician to do a thorough job of servicing in a minimum of time, the slight extra cost and effort that is involved in their use is well repaid. Most of the preparations that are available serve as insulators, cleaning agents, or cements; but there are other chemicals for specialized uses.

## Acrylic Spray

A solution of an acrylic plastic which is similar to Plexiglas can be sprayed on electronic equipment for insulating and moisture-proofing purposes. This liquid is supplied in pressurized cans that contain built-in spraying nozzles. A tough, very thin plastic coating forms on a sprayed object. Since this sheath of plastic will seal out air and moisture, acrylic spray is valuable for protecting the screws and mounting hardware of outdoor antenna systems from corrosion caused by damp air, salt spray, or air-borne impurities. Arcing or corona discharge through moist air surrounding a high-voltage circuit is also prevented by a plastic film on the circuit because the plastic has high dielectric strength as well as moisture resistance.

Applying acrylic spray evenly to a surface is a skill that can be developed with a little practice.

The operation is similar to spray painting, but it is difficult to see whether the sprayed object has been completely covered since the plastic spray is entirely colorless. It is a temptation to hold the nozzle close to the working surface and to apply a heavy coat of liquid, but this should not be done. Pools of liquid plastic will collect, and these will form slow-drying bulges which will be vulnerable to scratching and peeling when they finally dry.

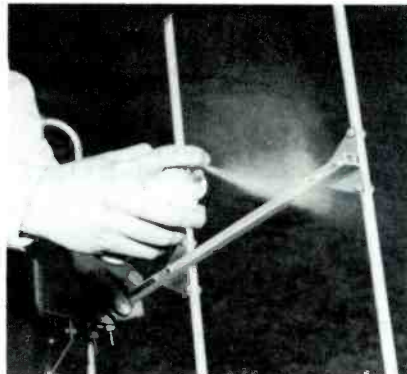

Fig. 1. Applying Acrylic Spray to Assembly Screws on an Antenna.

The best practice is to hold the spray nozzle from 8 to 12 inches away from the object being coated and to apply two or more light misty coats with a sweeping action. Fig. 1 shows an antenna being sprayed with plastic by this method. The first thin coat dries in less than five minutes, and the second coat may be applied immediately afterward.

The button which controls the

nozzle should be held down firmly while the spraying is being done. If the button is only partly depressed, the pressure of the spray will be too low and the coating will spatter over the surface. It is also important to keep the spray can moving at all times. A hesitation of only a moment will produce a thick spot in the finished plastic film.

Since the spray nozzle must be held at a distance from the object being sprayed, the area around the object will also be liberally coated. This should present no problem in the spraying of antennas, because an antenna should be sprayed outdoors at the installation site after the lead-in connections have been made. The lead-in terminals are more seriously affected by corrosion than any other parts of the antenna, and the finished lead-in connections should be protected with spray even if the rest of the antenna is not coated.

Acrylic plastic will do no harm if it is accidentally sprayed on leads and components in a receiver chassis, but the plastic must be kept away from tube sockets, switches, and other contact surfaces. They should be masked before any spraying is done on the chassis. If any plastic does penetrate into one of these places, it can be dissolved with lacquer thinner. Connections which are to be soldered do not need special protection from the spray because the heat of a soldering gun or iron will melt the acrylic plastic.

# MAKE MORE MONEY on every service call



NET \$109<sup>95</sup>

**B&K**

## DYNA-QUIK MODEL 500

DYNAMIC MUTUAL CONDUCTANCE TUBE TESTER

### Tests over 95%

OF ALL POPULAR TV TUBES\*—IN SECONDS

You can cut servicing time—eliminate repeat calls—make more on-the-spot tube sales—give a better service guarantee—make new profits in minutes with DYNA-QUIK. This top quality, low cost, portable dynamic mutual conductance tube tester enables any serviceman to locate weak and inoperative tubes quickly and easily with laboratory accuracy right in the home.

DYNA-QUIK creates greater customer confidence because your customer sees for himself the true tube condition on "Good-Bad" scale. In just a few minutes you can check all the tubes in a TV set for shorts, grid emission, gas content, leakage, dynamic mutual conductance and life expectancy under the dynamic heavily loaded conditions that are the actual operating conditions of the set. Used in the shop or in the home—DYNA-QUIK will make money for you every day!

- Fast—a complete tube test in as little as 12 seconds.
- Easy—one switch tests everything. No roll of art—no multiple switching.
- Accurate—large 4½" plastic meter has two scales calibrated 0-6,000 and 0-18,000 micromhos.
- Always up to date—test procedure instructions for new tubes supplied by factory at regular intervals.
- Automatic line compensation—special bridge continuously monitors line voltage.
- 7-pin and 9-pin straighteners mounted on panel.
- Portable—luggage style carrying case with removable slip-hinged cover.
- Lightweight—15¼ x 14½ x 5½ in. Weighs only 12 lbs.

\*Including new 600 mil series tubes.

**B&K**

Send for article on "Profitable TV Servicing in the Home" and Bulletin 500—R

Also makers of the famous CRT 400

**B&K MANUFACTURING CO.**  
3726 N. Southport Ave. • Chicago 13, Illinois

### Corona Dope

Corona dope is a liquid which has a thick consistency. When dry, it has a very high dielectric strength; and it is useful in preventing corona discharge and arcing if it is applied to high-voltage terminals. Various substances such as special lacquers and solutions of plastic are employed as corona dopes.

The dope should be daubed on with a brush, and the technician should allow plenty of time for it to dry. Power may not be safely applied to the treated circuit before the dope has completely dried, and the process of drying may take from 15 minutes to more than an hour.

Although the long drying time of corona dope is a disadvantage, several of its other characteristics are desirable. For example, a small amount of dope can be applied directly to a spot at which the arcing is to be eliminated. The dark color of the dope gives a positive indication of coverage, and the technician does not have to spray the whole area in an attempt to eliminate the arcing. If a second coat of either acrylic spray or corona dope is applied, the dielectric strength of the protective layer is increased for the simple reason that the layer becomes thicker.

Some liquefied plastics which resemble corona dope are intended to be used as substitutes for electrical insulating tape. The manufacturers of solutions of this type recommend that tool handles be dipped into the plastic for protection and for insulation. Handles that rust when attacked by the acids and moisture in perspiration can be well protected by only a thin coat of plastic dope, and this covering is neater than a wrapping of tape. We cannot freely endorse the electrical insulation qualities of plastic dopes for objects that must be handled, however, because a plastic coating which is not carefully applied may have bare or thin spots that will allow the passage of current.

Fig. 2A shows a pair of side-cutting pliers with plastic-coated handles. When the first coat of plastic was applied to these pliers, the plastic flowed slightly while drying. As a result, the coating



tended to become thin at the edges of the handles where insulation would be most greatly needed. If tool handles are covered with a liquid of this kind, it is especially recommended that two or more coats be applied. The weak spots in the first coat can be built up when the second coat is added.

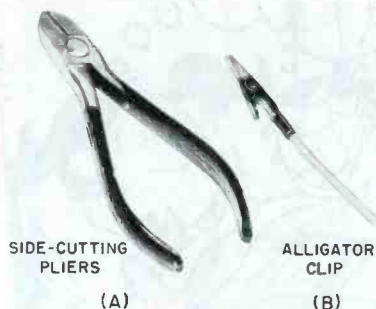

Fig. 2. Objects Coated with Plastic Dope.

Various uneven surfaces such as splices can be insulated with plastic dope more neatly than with tape if the technician does a careful job and covers the surfaces completely. The numbers of ways that plastic dope can be used are more or less proportional to the ingenuity of the user.

The alligator clip that is shown in Fig. 2B has been coated with a plastic dope so that only the jaws of the clip are exposed. This insulating clip makes an excellent tip for a test lead that must be fastened to a terminal in a crowded location. The clip should be attached to a terminal connection in such a manner that adjacent leads will touch only the insulated portion of the clip even if the clip should accidentally shift its position. The insulation minimizes the risk that the clip might cause a short circuit while a test measurement is being taken. The clip which is protected with plastic is less bulky and more manageable than a clip that has been insulated with tape.

The clip that is shown in Fig. 2B is not meant to be a device which can be connected to a circuit while the power is on. Extreme caution should be used if the clip is handled while voltage is being applied to it or to a near-

• Please turn to page 64

**JUST ONE WILL DO...**

**SO WHY BUY TWO?**

# AEROVOX TWIST-PRONG ELECTROLYTICS

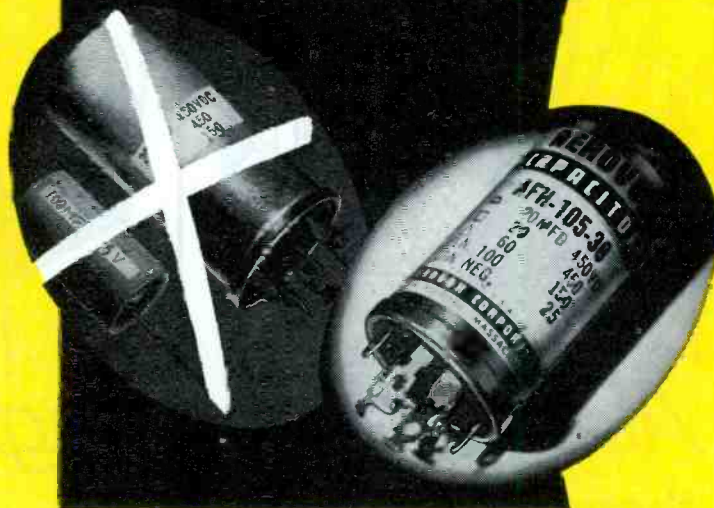

Voltages, capacitances, sections—in several hundred different combinations—go to meet today's twist-prong electrolytic capacitor replacement needs.

Such variety compounds the replacement headaches. Too bad the combinations are not kept to a minimum. But just so long as set designers insist on odd combinations, the replacements will have to include those combinations.

And so Aerovox faces the job squarely. Aerovox provides the biggest listing of twist-prong (Type AFH) electrolytics—by actual count, 290 to 345 more numbers than offered by any one of five competing brands. That is why Aerovox meets those replacement needs with single, economical, readily-installed units in place of multiple-unit makeshifts. And at considerably less cost!

Yes, ONE Aerovox will do... so why buy TWO from incomplete listings?

Ask your Aerovox distributor for copy of this handy pocket-sized AFH selector. Or write us.



## AEROVOX CORPORATION



DISTRIBUTOR SALES DIVISION,  
NEW BEDFORD, MASS.

In Canada: AEROVOX CANADA, LTD., Hamilton, Ont.  
Export: Ad. Auriemo, 89 Broad St., New York, N. Y. • Goble: Auriemo, N. Y.



For Almost Everything...  
there is the

# PERFECT REPLACEMENT

Some things can't be revitalized, no matter how many "boosters" are used—you have to face it, you can't get that original quality back again. However, a worn out, faded television picture can be done away with—because Du Mont has a *Perfect Replacement* for an old picture tube. To go even further, a Twin-Screen Hi-Lite\* picture tube will give a brighter, sharper, sparkling new picture—for a cost no greater than that of ordinary aluminized picture tubes. For picture perfection, for the *perfect replacement*, insist on Du Mont.

*\*The ultimate in aluminized picture tubes.*

## DU MONT<sup>®</sup>

CATHODE-RAY TUBE DIVISION, ALLEN B. DU MONT LABORATORIES, INC., CLIFTON, N. J.

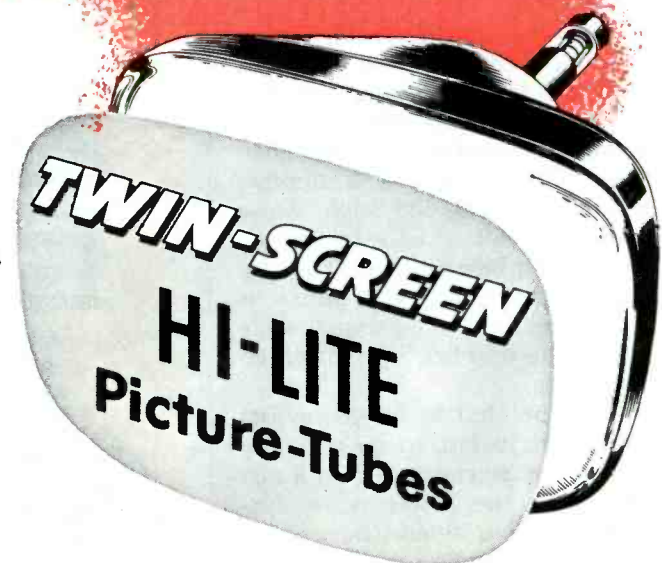



# Dollar and Sense Servicing

by | *John Markus*

Editor-in-Chief, McGraw-Hill Radio Servicing Library

**TV DX.** With increasing sunspot activity bringing freak long-distance television reception, the next two or three years should see a great increase in the number of those taking up TV DX-ing as a hobby. Even in 1955, some 65 fans were reported as having logged over 50 stations. Three enthusiasts have over 200 each to their credit, with Robert Seybold of Dunkirk, New York, leading; he logged 259 stations in 45 states and 6 countries, including 28 UHF stations. Seybold's distance record is just under 5,000 miles, according to *Radio-Electronics*.

Service technicians could well keep an eye out for newspaper accounts of long-distance TV reception and post each such story on a bulletin board in the shop. Window displays can feature high-gain antennas and rotators which are universally used by the DX-ers to bring in the signals good enough for station identification. A rotator that gives an accurate indication of direction on a control box alongside the set helps a lot in identifying stations that are fading out at station-break time, or it even eliminates waiting for the break if there are no other stations on or near that line-of-sight path. The real enthusiasts use souped-up sets with extra controls that permit changing the line rate to foreign standards, or they use an extra set permanently adjusted to those standards.

Working up enthusiasm locally for this hobby can well bring in a bit of profitable extra business. Many of those old Model 630 10-inchers can well be souped up and sold at a nice profit for DX purposes.

**Imports.** The trickle of radios coming into this country from Germany, Japan, and Holland is getting publicity far out of proportion to its volume largely because of newspaper advertising by large department stores that are importing directly. Estimates by the RETMA international department and other sources indicate that about 35,000 radios came from Germany in 1955, 25,000 from Japan, and 10,000 from Holland. The Japanese models include tiny transistorized sets having excellent sensitivity. Sales are largely based on novelty appeal, though the home and portable radios do have extra FM and short-wave bands in many models.



**Secrets.** One manufacturer is promoting a color TV receiver with new secret circuits. Does this mean that his sets can be fixed only by secret servicemen?



**Predictions.** The New Year began with nearly 37,500,000 TV sets in use. Industry experts say that another 7,000,000 sets will be sold in 1956 but only about 3,000,000 will go into new TV homes; the rest will be replacements and second sets.

As to color, they say it'll increase steadily but not spectacularly, with 150,000 to 300,000 color sets to be sold in 1956. NBC promises to increase its color hours from the current 40 hours per month to a new high of 80. No

drastic price breaks for sets are in the offing, and the many rumored new color picture tubes aren't expected to get into appreciable production this year.



**Good News.** Regulated power supplies made by Lambda Electronics Corporation come with a schematic diagram permanently mounted in every unit. A few test-equipment manufacturers do the same thing, and all the others could well follow the same practice. Separate service manuals are too easily lost after a few years; whereas, good equipment often lasts for more than ten years of daily use in a service shop.

How long would it take you to locate the schematic diagram for every piece of test equipment in your shop?



**Color Effects.** Ordinary black-and-white posters or slides for TV commercials can be transmitted in color by using a new RCA colorplexer in conjunction with an ordinary black-and-white camera. Any two colors can be chosen from an available 56. One color is electronically-added to the black portions of the picture, and the other color is added to the white portions. This technique permits stations to put on their own color commercials for network color programs long before they get their own color camera chains.

at



7 major quality checks

## ASSURE SUPERB CABLE PERFORMANCE

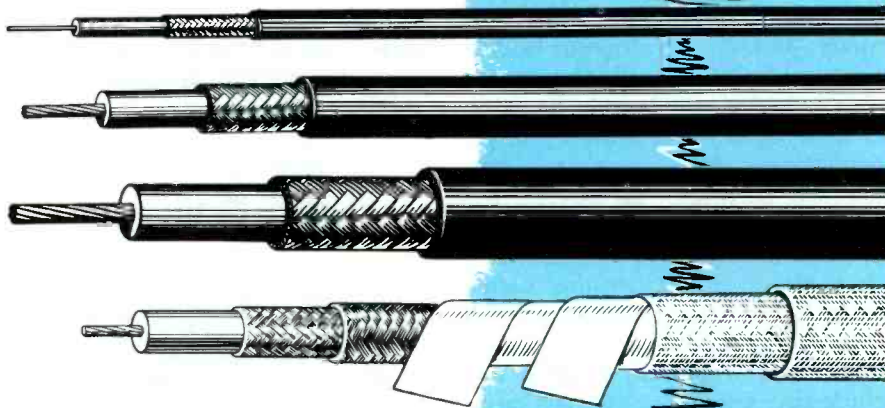

7 major quality checks, on the line and in the laboratory assure the top performance of dependable AMPHENOL coaxial cable.

- 1 Center conductor: lab check of mechanical and electrical characteristics.
- 2 Dielectric: rolling micrometer checks dimensions during extrusion.
- 3 Finished Core: micrometer checked again before jacketing.
- 4 Shielding: checked after braiding for percentage of coverage, loose ends, tightness.
- 5 Jacket: inspected 100% during extrusion.
- 6 Complete cable: special lab check of every run, electrically and mechanically.
- 7 Complete cable: every foot extruded is run through automatic machinery for final dimensional check.

Constant inspection and testing during manufacture, the use of fine materials, modern equipment, skilled workmen: all are combined at AMPHENOL. Specify and insist upon AMPHENOL coaxial cables!



CHECK WITH YOUR AMPHENOL DISTRIBUTOR FOR EVERY CABLE NEED

AMERICAN PHENOLIC CORPORATION  
chicago 50, illinois  
AMPHENOL CANADA LIMITED toronto 9, ontario



Braking. Now under consideration for some 1957 auto models is a radar-controlled brake system that will cost around \$300 extra. The antenna mounts ahead of the radiator grille, and the circuitry fits into the glove compartment, in the demonstration car now being tested in Detroit. Brakes are applied by the radar with a force proportional to the object distance. The driver may also brake manually; and he may disconnect the radar by flipping a switch if, for example, he is driving into a garage or pushing another car.

If radar-controlled brakes gain popularity in the auto industry, additional servicing business could well equal that of TV. About 7,000,000 radio sets went into some 8,000,000 cars in 1955, which just about equals the year's TV production of 7,400,000; so, the potential markets are about the same. Keep an eye on auto radar, and let's hope it goes farther faster than did electronic headlight dimmers.



Handymen. With do-it-yourselfism in full stride, doctor bills are replacing repair bills. Statistics from the American Mutual Liability Insurance Company reveal that about 600,000 of these unhandy handymen hurt themselves last year, and the erection of TV antennas got the credit for 16,400 of the accidents. Some of the other reasons for seeing the doctor were: painting the house—107,000, pruning trees—37,000, repairing window panes—95,000, changing storm windows—47,000, cleaning gutters—57,000, painting chimneys—11,000, carpenter work—115,000.

The obvious moral is: Do only what you are trained to do, and use the classified telephone directory to locate experts for the other jobs, despite what your wife says. And to help keep other men from breaking their necks putting up TV antennas, be sure your own servicing ad is easy to find in your local classified telephone directory.

• Please turn to page 61

a **VOM** ... plus a **VTVM** when you need it.  
**DOUBLE USE... HALF THE PRICE**  
**TRIPLETT MODEL 631**—In one year accepted as the  
 standard **COMBINATION VOM-VTVM**



**Battery operated**

- 1** Just flip the switch.
- 2** Standard sensitivities as used in servicing manuals.
- 3** 34 ranges—with the famous Triplett single knob control.
- 4** Extra long scales—unobstructed visibility.

**\$59.50**

By using the Volt-Ohm-Mil-Ammeter for all general testing (90% of your testing) and the Vacuum Tube Voltmeter only when you need it, you have the advantage of a VTVM with extremely long battery life. Batteries are used only about one-tenth as much as in the ordinary battery-operated VTVM. Features: Ohms, 0-1500-15,000 (6.8-68 center scale. First division is 0.1 ohm.)

Megohms: 0-1.5-150 (6,800-680,000 ohms center scale.) Galvanometer center mark "—0+" for discriminator alignment. RF Probe permits measurements up to 250 MC. \$7.00 net extra. Featured by leading electronic parts distributors everywhere.

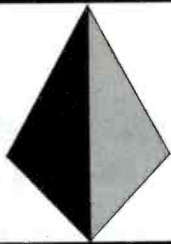

**TRIPLETT ELECTRICAL INSTRUMENT COMPANY • 52 years of experience • BLUFFTON, OHIO**  
*Triplett design and development facilities are available for your special requirements for meters and test equipment.*

**NO. 57**

# PYRAMID

## technical

## bulletin

### THERE IS MORE TO A CAPACITOR THAN ITS DESIGN FORMULA:

$$C = \frac{K D}{A}$$

Pyramid's production and life tests of their capacitors are among the most stringent in the industry. Production test for voltage breakdown, capacitance, power factor, insulation resistance and seal are performed on 100% basis. In consisting of life, temperature and immersion cycling, vibration, and corrosion where applicable. These serve to guarantee that the capacitors you purchase are consistently as represented to be.

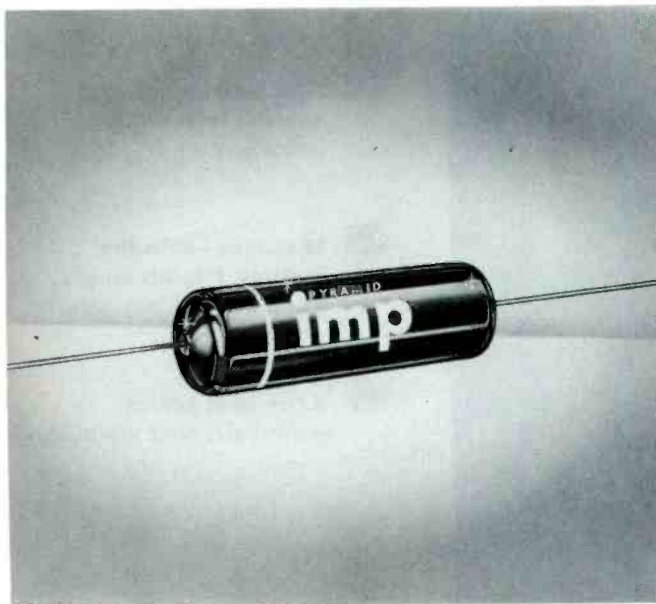

Pyramid capacitors also owe their exceptional performances to the type of materials used in their manufacture and the production methods which Pyramid engineers have devised. For example, in the new Pyramid IMP capacitor, a new, exclusive plastic molding technique was developed which bonds casing, impregnated element, and tinned copperweld leads into one compact assembly capable of withstanding severe physical abuse. In addition, this unit is heat and moisture resistant withstanding the RETMA humidity-resistance test to a remarkable degree. In another capacitor, type MT metallized paper units, vacuum impregnation is employed and the ends of the capacitor are sealed with plastic. Then, as a final step, the entire unit is completely coated with a highly moisture resistant wax. It is production techniques such as these which, in conjunction with high quality papers, impregnants (such as Halowax, Mineral Oil, or Silicone Base Synthetic Oil), and metals, that account for the excellent stability and long life that Pyramid capacitors exhibit.

Pyramid capacitors, particularly electrolytic capacitors, are specifically designed for long shelf life. To achieve this goal requires that the various materials and chemicals used in the manufacture of these units possess a high quality and long term stability. Another contributing factor to long shelf life is the care which is taken to provide maximum protection against the corrosive effects of chemicals in the atmosphere. This necessitates a container which is well insulated against the intrusion of moisture, i.e., one which is air tight and hermetically sealed.

\* \* \* \*

The number of different types of capacitors that Pyramid manufactures is extensive. Included in this line are the following:

1. Electrolytic capacitors, type TD, with each unit sealed in a metal tubular case. Available in single sections, dual sections, and triple sections.
2. Electrolytic capacitors in screw base metal containers, type MC. Available in single and dual sections.
3. Twist-Mount electrolytic capacitors, type TM. Available in single, dual, and triple sections. Different sections may have different working voltages.
4. HI-TEMP Twist-Mount Electrolytic capacitors, type TWH. Designed for 100°C operation.
5. Dry Electrolytic capacitors in wax-filled, impregnated cardboard tubes, type CDB. Available in single, dual, and triple sections. Sections may possess individual leads or share a common negative terminal.
6. Plug-in Electrolytic capacitors, type DO, provided with 4 pins on standard octal base.
7. High-capacitance, low voltage electrolytic capacitors, type PFB.
8. Molded tubular paper capacitors, type IMP.
9. Miniature tubular paper capacitors. Type 85LPT.
10. Ceramic-cased tubular paper capacitors, type CT.
11. Bathtub-Type Oil-Paper Capacitors, types PDM, PDMT, PDMB.
12. Metal-tubular Oil-Paper capacitors, types PTIM, PTDMV, 4PTIM, 4PTIMV, 7PTIM.
13. Small-base oil-paper capacitors, types PKM, PKMF, PKMS, PKMT, and PKMB.
14. High-voltage oil-paper capacitors, types PLM, PLMF, PLMS, PLMU, PLMR.
15. Kraft-tube metallized paper capacitors, type MT.
16. Metal-can metallized paper capacitors, types MPGK, MPGM.
17. Metal-tube metallized paper capacitors, types MPTIK, MPTIM.
18. "Glasseal" subminiature paper tubular capacitors, and many others.

Pyramid capacitors are competitive in price because of the modern production methods that are employed throughout every phase of capacitor production. Whenever possible, automation techniques are being applied so that more uniform high quality may be achieved. Much of Pyramid's success is due also to the aggressiveness of Pyramid engineers in pioneering new products.

**PYRAMID ELECTRIC CO.**

North Bergen, New Jersey

**FOR COMPLETE DATA SEND FOR ENGINEERING BULLETIN—FORM IMP-2**
**SEE US AT BOOTH 586  
AT THE I. R. E. SHOW**
**PYRAMID IS THE BIG NAME IN CAPACITORS AND SELENIUM RECTIFIERS TODAY!**

# Stocking the Tube Kit

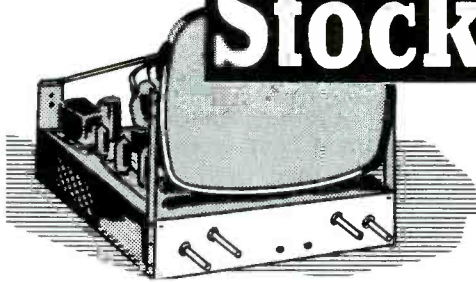

## SUGGESTED MINIMUM STOCK REQUIREMENTS FOR DELUXE OR STANDARD TUBE KITS

A suggested list for stocking the tube kit appeared in the January 1954 issue, and a revised list appeared in the January 1955 issue of the *PF REPORTER*. The tube complements of television receivers are continually changing, and the stock of tubes carried in the tube kit should reflect these changes. It is for this reason that a second revised list has been

prepared. Chart I contains the list for the de luxe kit, and Chart II contains the list for the standard kit.

As color television receivers become more prevalent, additional tube types will have to be carried by the service technician who engages in color servicing. Among these types are the 3A2, 3A3, 6BC7, 6BD4, 6CB5, and 6CL5 tubes.

The development of new tubes for use in series-filament and other new types of receivers will also affect the types of tubes carried in the kit. When these new tubes become more commonly used, the service technician may augment his tube stock with the appropriate types. The series-string tubes used in current models of TV receivers are listed in Chart III.

**CHART I**  
Tube Complement for the De Luxe Kit

TUBE TYPES	TV MODELS		TUBE TYPES	TV MODELS		TUBE TYPES	TV MODELS		TUBE TYPES	TV MODELS	
	46-56	52-56		46-56	52-56		46-56	52-56		46-56	52-56
1B3GT	2	2	6AL5	2	2	6BG6G	2	2	6CU6	1	1
1X2(A)(B)	2	2	6AM8	0	1	6BH6	1	0	6J5(GT)	1	1
3CB6	0	1	6AN8	0	1	6BK5	1	1	6J6	3	2
5U4G	4	4	6AQ5	2	2	6BK7(A)	2	2	6K6GT	2	1
5U8	0	1	6AS5	1	1	6BL7GT	1	1	6S4	1	1
5V4G	1	0	6AT6	1	1	6BN6	1	1	6SL7GT	1	0
5Y3GT	2	1	6AU5GT	1	1	6BQ6GT	2	2	6SN7GT(GTA)	5	5
6AB4	1	1	6AU6	3	3	6BQ7(A)	2	3	6SQ7(GT)	1	1
6AC7	2	2	6AV5GT	1	1	6BZ7	1	1	6T4	1	1
6AF4	2	1	6AV6	2	2	6C4	2	1	6T8	2	1
6AG5	2	1	6AX4GT	2	2	6CB6	3	3	6U8	1	1
6AG7	1	1	6AX5GT	1	1	6CD6G	2	2	6V3(A)	1	1
6AH4GT	1	1	6BA5	1	1	6CF6	0	1	6V6GT	2	2
6AH6	1	1	6BC5	2	1	6CL6	0	1	6W4GT	3	3
6AK5	1	1	6BE6	1	1	6CS6	1	1	6W6GT	1	1
									6X8	1	1
									6Y6G	1	1
									12AT7	2	2
									12AU7	3	2
									12AV7	1	1
									12AX4GT(GTA)	1	1
									12AX7	1	1
									12AZ7	0	1
									12BH7	1	1
									12BY7	1	1
									12BZ7	1	0
									12SN7GT	1	1
									25BQ6GT	1	1
									25L6GT	1	1
									25W4GT	1	1

**CHART II**  
Tube Complement for the Standard Kit

TUBE TYPES	TV MODELS		TUBE TYPES	TV MODELS		TUBE TYPES	TV MODELS		TUBE TYPES	TV MODELS	
	46-56	52-56		46-56	52-56		46-56	52-56		46-56	52-56
1B3GT	1	1	6AL5	1	1	6BK5	1	1	6J5(GT)	1	1
1X2(A)(B)	1	1	6AQ5	1	1	6BK7(A)	1	1	6J6	2	1
3CB6	0	1	6AS5	1	1	6BL7GT	1	1	6K6GT	1	1
5U4G	3	3	6AT6	1	1	6BN6	1	1	6S4	1	1
5V4G	1	0	6AU5GT	1	1	6BQ6GT	1	2	6SN7GT(GTA)	3	3
5Y3GT	1	1	6AU6	2	2	6BQ7(A)	2	2	6SQ7(GT)	1	1
6AB4	1	1	6AV5GT	1	1	6BZ7	1	1	6T4	1	1
6AC7	1	1	6AV6	1	1	6C4	1	1	6T8	1	1
6AF4	1	1	6AX4GT	1	1	6BC6	2	2	6U8	1	1
6AG5	1	1	6AX5GT	0	1	6CD6G	1	1	6V3(A)	1	1
6AG7	1	1	6BA6	1	1	6CF6	0	1	6V6GT	1	1
6AH4GT	1	1	6BC5	1	1	6CL6	0	1	6W4GT	2	2
6AH6	1	1	6BE6	1	1	6CS6	1	1	6W6GT	1	1
6AK5	1	1	6BG6G	1	1	6CU6	1	1	6X8	1	1

**CHART III**  
New Tubes Appearing in Series-String Receivers

TUBE TYPES	TUBE TYPES	TUBE TYPES	TUBE TYPES	TUBE TYPES
2AF4	3CS6	5BK7A	6CG7	12CA5
3AL5	4BQ7A	5J6	6S4A	12CU6
3AU6	5AM8	5T8	6SN7GTB	12L6GT
3AV6	5AN8	5V6GT	12B4A	19AU4
3BC5	5AQ5	5X8	12BH7A	25CD6GA(GB)
3BN6	5AT8	6AU8	12BK5	25CU6
3BZ6	5AU4	6AW8	12BQ6GA(GTA)(GTB)	
3CF6	5AV8	6BZ6	12BY7A	



Get both . . .  
**TOP CONVENIENCE**  
**... LOWEST COST**

Another Hycon test help . . .



**MODEL 617**  
**3" SCOPE**

. . . gives you a full 3" of undistorted trace on special flat-face CRT. Laboratory accuracy, field ruggedness.

You expect accuracy in a VTVM. Hycon's Model 614 offers economy, too . . . plus versatility you'd never look for in an instrument of its price. Response to 250 MC (with accessory probes) . . . 21 ranges (28 with p-p scales) . . . electrostatic and electromagnetic shielding . . . and a real convenience for the user: TEST PROBES STOW INSIDE THE CASE.

*"Where Accuracy Counts"*  
**Hycon ELECTRONICS, INC.**  
 A Subsidiary of Hycon Mfg. Company  
 321 SOUTH ARROYO PARKWAY  
 PASADENA, CALIFORNIA

Send **TODAY** for latest catalogs

HYCON ELECTRONICS, INC., Dept. P.  
 P. O. Box 749  
 Pasadena, California  
 Send the latest catalogs on Model 614 and Model 617.

Name \_\_\_\_\_  
 Address \_\_\_\_\_  
 City \_\_\_\_\_ State \_\_\_\_\_

**Shop Talk**

(Continued from page 15)

across the base-to-collector junction, but the bulk of  $I_{co}$  stems from the heat energy.)

Since heat is the basic source of  $I_{co}$ , then the higher the operating temperature of the transistor the higher  $I_{co}$  will be. Furthermore, when the transistor is connected into an amplifier circuit,  $I_{co}$  will develop a voltage while flowing through the base because of base resistance. This voltage will actually aid the emitter voltage and so increase the emitter current, and this action can be seen readily by reference to Fig. 2 in which we have a p-n-p junction transistor connected with the proper operating biases.  $R_L$  is the load resistor in the collector circuit, and  $R_b$  stands for the internal resistance of the base section. Let us now disregard the normal emitter and collector currents and follow only the path of  $I_{co}$ . This will flow in the direction indicated

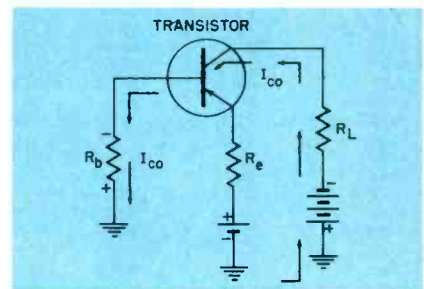

Fig. 2.  $I_{co}$  Flowing Through any Resistance in the Base Circuit Will Develop a Voltage Which Will Aid the Externally Applied Emitter Voltage.

by the arrows and, in passing through  $R_b$ , will develop a voltage with the polarity indicated. Note that this potential will add to the normal emitter voltage and will increase the bias between the emitter and the base. The result is more current from the emitter through the base to the collector. This, of course, will raise the operating temperature and further increase  $I_{co}$ ; the cumulative increase may in time cause the destruction of the transistor.

**Heat Dissipation**

Because of this sensitivity to temperature, great care must be taken to see that the maximum





**Jensen** *Authentic*  
**HIGH FIDELITY  
 LOUDSPEAKER KITS**

High Fidelity Installation For the Home by  
 John and Jean Wehrheim, Architects.

If you are planning to build-in your high fidelity system, you'll find a JENSEN Authentic High Fidelity Loudspeaker Kit not only gives superb performance but adds convenience and a note of simplicity to the whole project. Your builder or cabinet maker can easily follow the basic selected enclosure plan for the system you choose, (or do-it-yourself). New Manual 1060 tells all you need to know in simple terms, describes the eight JENSEN Loudspeaker Kits, and helps you make an intelligent choice of degree-of-performance.

Of course you can build your own free-standing speaker system if that is the arrangement you prefer. Again, Manual 1060 tells all. Why not order a copy today for only 50 cents.

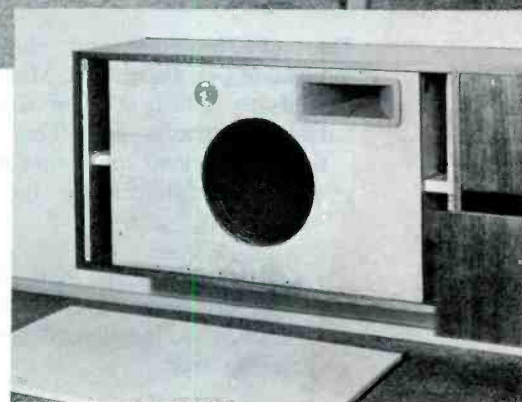

Installation of Jensen Speaker System Kits  
 is easy — No Technical Skill Required.



Components For the Jensen KT-32 Triplex  
 3-way System Loudspeaker Kit.

**Jensen** MANUFACTURING COMPANY  
 Dept. M, 6601 S. Laramie, Chicago 38, Illinois  
 Division of the Muter Co. • In Canada, Copper Wire Products, Ltd. Licensee  
**WORLD'S QUALITY STANDARD FOR MORE THAN A QUARTER CENTURY**

**SEND FOR BIG 36 PAGE  
 MANUAL FOR BUILDING  
 YOUR OWN ENCLOSURES**

Select the Kit and Cabinet you want from this complete manual of do-it-yourself designs. Simplified drawings, parts lists, speaker data—all planned to help you. Send 50¢ in coin for Manual 1060 today!



... another  
**MALLORY**  
 service-engineered  
 product

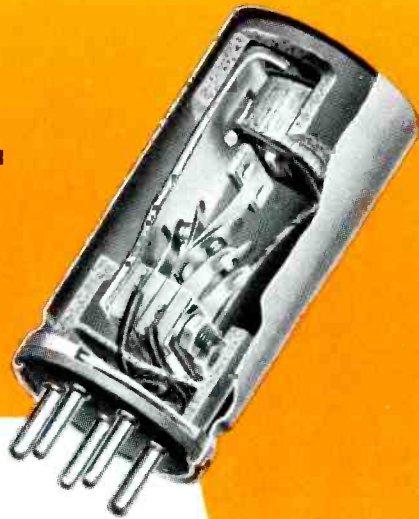

## There's *extra life* in this **NEW MALLORY Vibrator**

Contact "bounce" and chatter are eliminated in this latest Mallory self-rectifying vibrator. New dual spring design is the reason. This construction gives clean make-and-break, and provides dynamically balanced self alignment.

**COUNT ON THEM FOR LONGER LIFE,**  
 and freedom from occasional early failure... for extra service *without* extra cost.

**COUNT ON MALLORY,**  
 leader in vibrator progress, for continued improvements in performance of all types of vibrators.

Your local Mallory distributor is stocked with the new vibrators, in both shunt drive (shown here) and separate drive models. Order from him now... and make these your standard replacement for all commercial jobs needing self-rectifying units.

**P. R. MALLORY & CO. Inc.**  
**MALLORY**

P. R. MALLORY & CO. Inc., INDIANAPOLIS 6, INDIANA

- Capacitors
- Vibrators
- Resistors
- Power Supplies
- Mercury Batteries
- Controls
- Switches
- Rectifiers
- Filters

operating temperature is not exceeded. In charts of transistor characteristics, the maximum collector dissipation is specified at a definite temperature (such as 25 or 40 degrees centigrade). If the operating temperature exceeds this value, then it becomes necessary to lower the dissipation rating of the collector. For example, Sylvania Products, Inc., indicates that the maximum dissipation rating should be derated (lowered) one milliwatt for each degree centigrade of increase in ambient (or surrounding) temperature; therefore, if the maximum rating for a certain transistor is 50 milliwatts at 25 degrees centigrade, then the derated maximum rating would only be 45 milliwatts at 30 degrees centigrade, and so on.

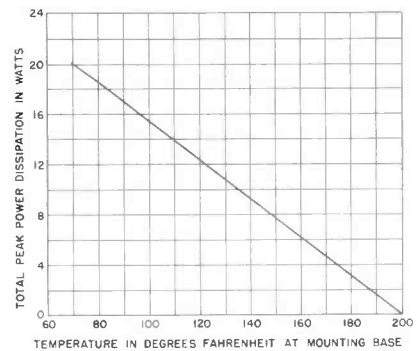

Fig. 3. Heat Dissipation Chart for Type 2N57 Power Transistor Developed by Minneapolis-Honeywell Regulator Co.

Minneapolis-Honeywell Regulator Company provides the chart shown in Fig. 3 for its 2N57 power transistor. The slope of the curve is very steep; the total peak dissipation drops from 20 watts at 70 degrees Fahrenheit to about 9 watts at 140 degrees Fahrenheit.

Sometimes two maximum ratings will be given—the lower one in free air, the other one when the transistor is mounted flush against a metallic surface (such as a chassis) which will dissipate the heat. The technical name for this heat conductor is "heat sink," and its use can make an appreciable difference in the maximum dissipation rating. The Sylvania 2N95 n-p-n junction transistor has a collector dissipation rating in free air of 2.5 watts and a rating of 4.0 watts when mounted flush against an aluminum chassis.

This is a significant point to keep in mind, particularly when the transistor is to be operated near its maximum rating.

To aid in heat dissipation, power transistors are built with radiating fins (Fig. 4) and in metal housings (Fig. 5). Internal heat is transferred to the external metal case by metallic conduction with very little drop in temperature. The metal conducting surface may be soldered to any of the three transistor elements. In the power transistor of Fig. 5, the outer metal cup is soldered to the collector.



Fig. 4. A Power Transistor with Radiating Fins to Improve Heat Dissipation. (Photograph Courtesy of Sylvania Electric Products, Inc.)

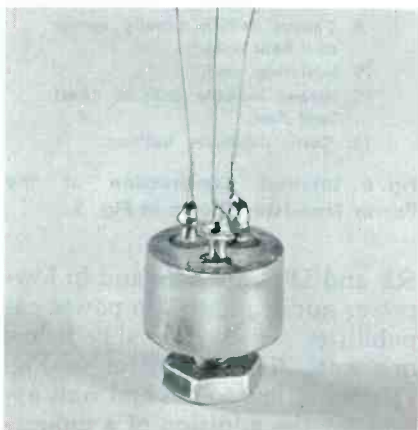
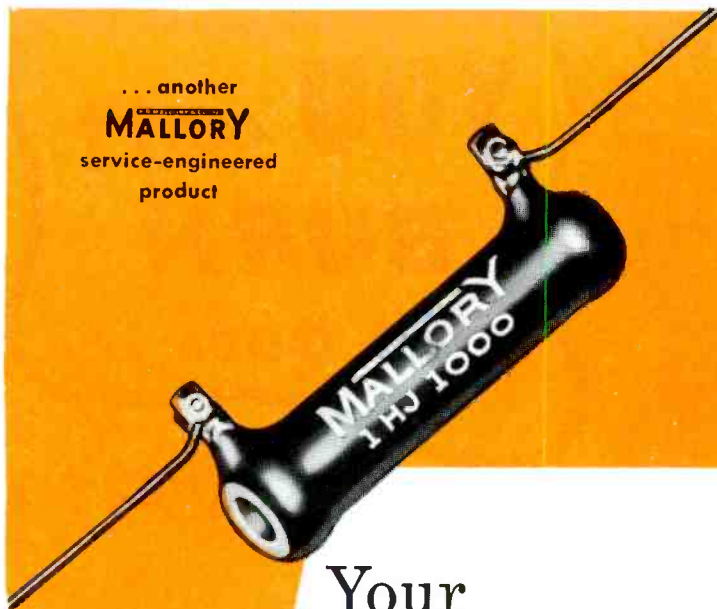

Fig. 5. Power Transistor Developed by Minneapolis-Honeywell Regulator Co.

A cross-sectional view of this power transistor is shown in Fig. 6. Note how the collector (item 5) is set flush against an inner surface of the metal housing. If the design of the circuit permits, the transistor is mounted against the chassis; and the maximum dissipation of heat would be assured. If the collector must be electrically insulated from the chassis, however, there would be a small insulating washer (item 7) on one

... another  
**MALLORY**  
service-engineered  
product



## Your best choice in wire-wound resistors

Whenever you replace a wire-wound bleeder, load resistor or voltage divider, you can make the job sure by using Mallory vitreous enamel resistors. From the inside out, they're built for real stability and long service.

Low temperature coefficient wire is space wound on a high quality steatite core, and is protected by a special non-porous, non-alkaline enamel coating that protects permanently against moisture and corrosion. A special design of the terminal bands assures fool-proof connection.

Mallory wire-wounds run cool, for they are conservatively rated under actual inside-chassis service. Your Mallory distributor carries them in a complete range of resistance values . . . in the popular 10-watt size illustrated, and in 5, 20, 50, 100 and 200-watt ratings. See him today!

- Capacitors
- Vibrators
- Resistors
- Power Supplies
- Controls
- Switches
- Rectifiers
- Filters
- Mercury Batteries

P. R. MALLORY & CO. Inc.  
**MALLORY**  
P. R. MALLORY & CO. Inc., INDIANAPOLIS 6, INDIANA



**YOU can't  
BURN  
it out!**

**HICKOK  
MODEL 456**



- Exclusive overload cut-out system.
- Protection of all practical ranges.
- Protects meter and entire internal circuit against accidental burn-outs.

Greatest engineering achievement in VOM history

*Latest Design*

**VOLT-OHM-MILLIAMMETER**

The Model 456 is a new portable multimeter that incorporates the latest engineering advancements including the new technique that protects both meter and the entire internal circuit against accidental burn-outs. In fact, any high voltage or current may be applied directly across any function, including ohms, without danger to the meter movement or associated components.

This instrument has a sensitivity of 20,000 ohms per volt DC and 1,000 ohms per volt AC. The 456 also includes DB ranges and provision for output measurements.

**THE HICKOK ELECTRICAL INSTRUMENT CO.**  
10566 Dupont Avenue • Cleveland 8, Ohio

Ask for a demonstration of this most practical VOM from your Radio-Electronic Parts Jobber today! . . . Or write direct for technical details.

side of the chassis and a nylon bushing (item 11) to insulate the stud and nut from the other side of the chassis.

The three photographs in Fig. 7 show the changes in the size and construction of transistors as a result of changes in power dissipation. The transistor in Fig. 7A is a standard unit which is used in

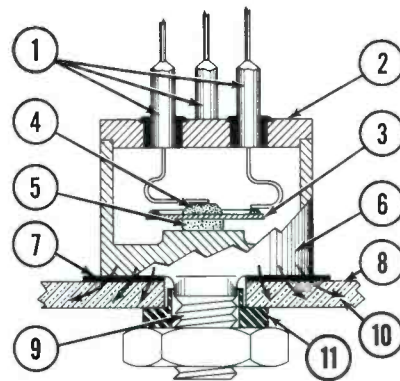

**LEGEND**

1. Emitter, collector, and base lead wires.
2. Hermetically sealed metal top.
3. Base (germanium crystal wafer with nickel reinforcing ring).
4. Emitter (indium metal).
5. Collector (indium metal).
6. Metal case.
7. Mica insulator.
8. Chassis (which usually serves as a heat sink).
9. Mounting stud.
10. Arrows indicate path of direct heat flow.
11. Plastic insulator bushing.

Fig. 6. Internal Construction of the Power Transistor Shown in Fig. 5.

RF and IF amplifiers and in low-power audio stages. Its power capabilities are considerably below one watt. The transistor in Fig. 7B is identical to the first unit except for the addition of a mounting bracket for heat dissipation. This transistor would be used in medium-power amplifiers in which the heat to be dissipated is somewhat less than one watt. The third unit, Fig. 7C, is specifically labeled as a power transistor and is designed for applications requiring a dissipation as high as 10 watts.

Power transistors have also been developed with removable fin structures. This type offers the advantage that the fin structure can be changed to accommodate the particular power that the

transistor has to dissipate. A small fin structure would be employed for relatively low-power outputs, and a large fin structure would be employed for high-power outputs.

In another experimental power transistor, the unit was encased in a liquid-filled metal shell. Whatever heat was generated was then transferred to the outer metal case by the liquid coolant.

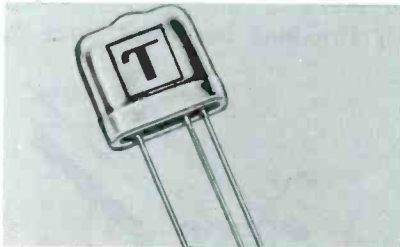

(A) For Low Power.

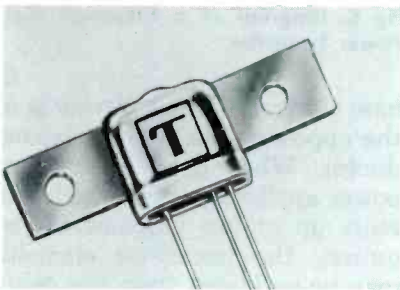

(B) For Medium Power.



(C) For High Power.

Fig. 7. Power Transistors. (Photographs Courtesy Transiron Electronic Corporation.)

Forced-air cooling will also aid in heat removal, and this method is used in commercial and industrial equipment in which the additional power obtainable is important.

While the stress has been centered on heat-dissipation methods, the reader will also recognize that changes will be required in

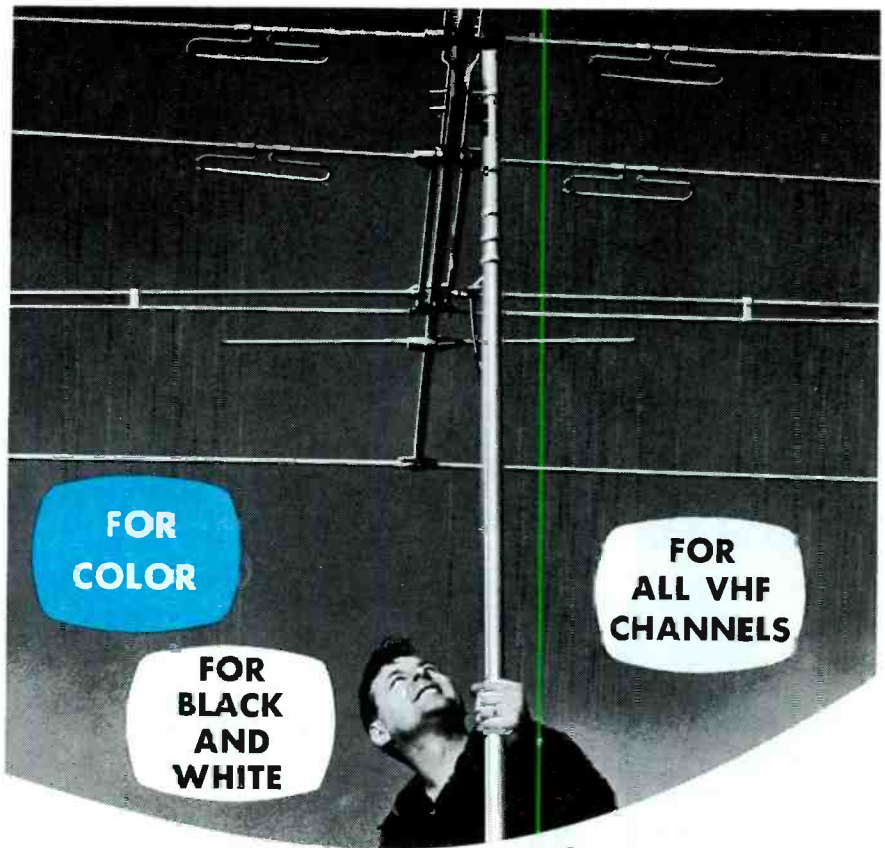

another installation...  
*on the beam!*

with a **TACO**  
**TRAPPER**

A job well done! You can guarantee the very best reception for the customer, and there'll be no costly call-backs or complaints when you install one of the Taco family of Trapper antennas. The Trappers will outperform and outlast all the other antennas in the neighborhood.



**SUPER TRAPPER**

Working elements  
—24 high band and  
7 low band.  
Gain up to 12 DB on  
high band and  
9 DB on low band.



**TRAPPER**

Working elements  
—15 high band and  
5 low band.  
Gain up to 10 DB on  
high band and  
7 DB on low band.

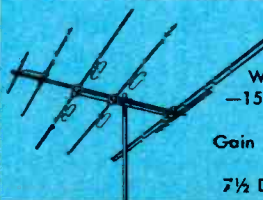

**TRAPPER ROYAL**

Working elements  
—15 high band and  
5 low band.  
Gain up to 11 DB on  
high band and  
7½ DB on low band.



**TRAPPER JR.**

Working elements  
—7 high band and  
3 low band.  
Gain up to 8 DB on  
high band and  
3½ DB on low band.

**TECHNICAL APPLIANCE CORPORATION • SHERBURNE, N. Y.**  
In Canada: Hackbusch Electronics, Toronto 4, Ont.

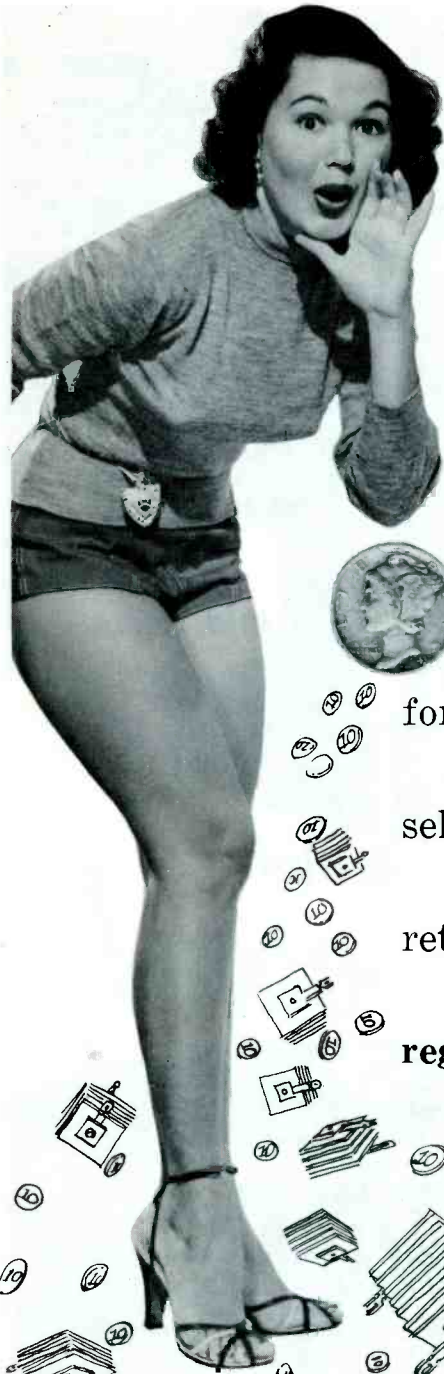

HAVE YOU  
HEARD that  
our distributors  
will allow you  
10c credit  
for each replaced  
selenium rectifier  
returned —  
regardless of make?

The selenium situation is critical, and reclamation is necessary to meet civilian, as well as military requirements. You can help by returning every replaced selenium rectifier to your distributor for credit.

**Sarkes Tarzian, Inc., RECTIFIER DIVISION** 415 N. COLLEGE AVE. BLOOMINGTON, INDIANA

In Canada: 700 Weston Rd., Toronto 9, Tel. Murray 7535

Export: Ad Auriema, Inc., New York City

the construction of the transistor elements themselves. These consist of changes in the resistivity of the germanium; modifications in the shape and size of the emitter, base, and collector elements; and the development of different methods of forming the transistor. One type of power transistor possesses the configuration shown in Fig. 8. The emitter is a long bar positioned on the semiconductor crystal and flanked on either side by two long bars that form the

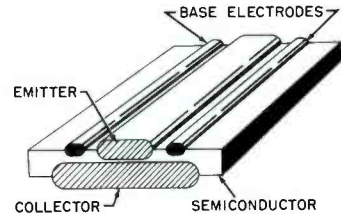

Fig. 8. Diagram of a Proposed High-Power Transistor.

base electrode. The collector is on the opposite side of the semiconductor. When used in medium-power applications for which currents up to two amperes are required, the transistor elements may be no longer than one centimeter. The electrodes may be made longer for higher-current requirements, or two or more of these transistor structures may be placed in parallel. If many bars are used, they may be connected together into a comblike structure.

#### Silicon Transistors

Another possible avenue to higher-wattage capability is through the use of silicon. Silicon is suitable for diodes and transistors because its physical properties closely parallel those of germanium. Silicon is a semiconductor with four valence electrons; and in the solid state, it will form a cubic crystal lattice in which the various atoms are held together by the same mechanism of covalent bonds. It is possible to replace some of these atoms by impurities, either of the donor or acceptor variety, and form n-type or p-type silicon. Rectifier diodes or complete transistors can be fabricated with suitable combinations of these types of silicon.



look to the little Indian  
to give your customers  
the **BEST** in replacement  
electrolytic capacitors

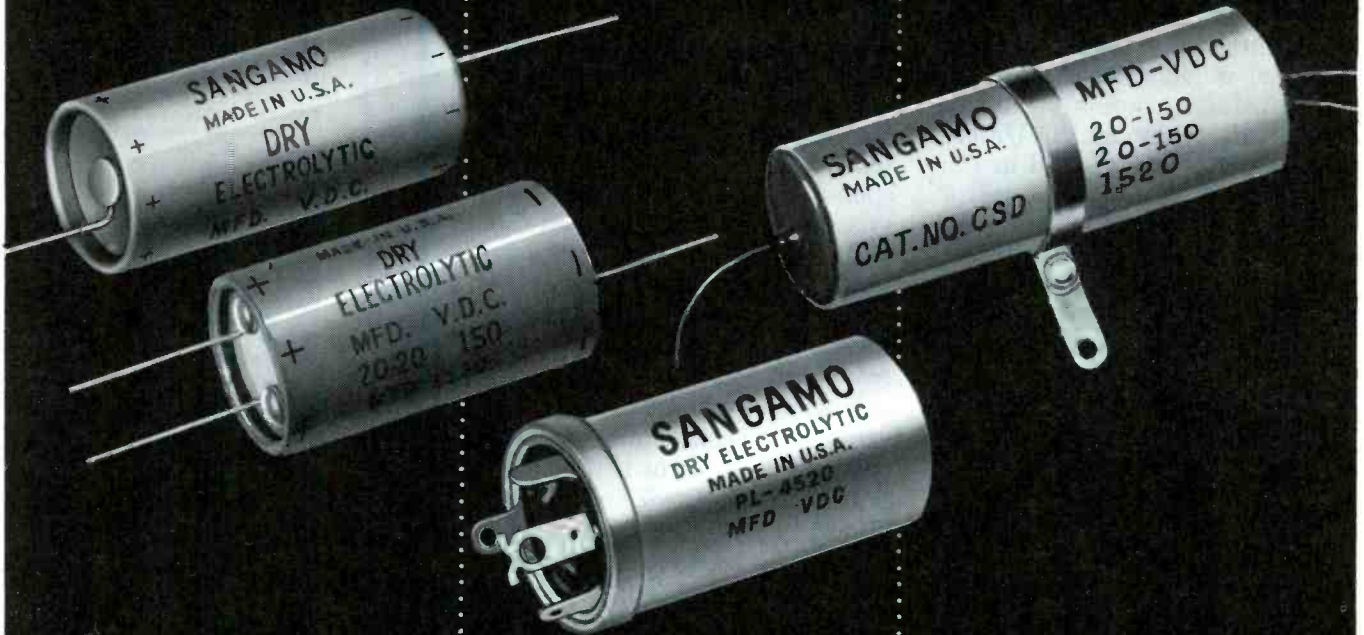

**SANGAMO Type MT "Chieftains"**

Specially designed for television and other electronic applications where operation at 85° C is required . . . hermetically sealed in round aluminum containers . . . small size makes them good for mounting in limited space . . . they fit anywhere and can be mounted in almost any position.

**SANGAMO Type PL "Warrior"**

These twist-tab electrolytics are used as original equipment by all major manufacturers . . . they are exact replacements . . . assure long life and dependable performance at 85° C and under conditions of high surge voltages and extreme ripple currents.

**SANGAMO Type CS "Tomahawk"**

These electrolytic capacitors are contained in wax-filled cardboard tubes with insulated leads approximately 8 inches in length extending from both ends of the unit. Each unit is supplied with a mounting strap to facilitate mounting to the chassis.

**Plug-in electrolytics for printed circuit replacement too!**

These dry electrolytic plug-in capacitors are exact replacements for most of the new sets with printed circuit chassis. Stock up now!



*Those who know*  *choose Sangamo*



**SANGAMO ELECTRIC COMPANY**  
MARION, ILLINOIS

In view of the physical similarities between germanium and silicon, it is only natural that both substances would be investigated to determine which is best suited for transistor operation. Actually, as we shall see, there are certain advantages and disadvantages to either type; and it becomes a matter of choosing the material that possesses the greatest suitability for a specific application.

Of the two substances, silicon is far more abundant in nature than germanium. As a matter of fact, silicon compounds form more than 85 per cent of the materials found in the earth. All sand, for example, is silicon dioxide; and additional compounds of it are present in many rocks. Unfortunately, it is never found in the free state; and in order to utilize it for transistor manufacture, extensive separation and refining methods must be employed. This represents a major obstacle, because silicon is not easily reduced to the pure state. It is an extremely difficult substance to melt or purify; its processing requires high-powered, complex, and expensive electric furnaces. Furthermore, the methods which have been successful to date are difficult to adapt to mass production, a requirement that is absolutely necessary if silicon transistors are to possess commercial usefulness.

One of the most important advantages which is in large measure responsible for much of the attention being devoted to silicon is the low collector-saturation current  $I_{co}$  which silicon transistors exhibit. It will be recalled that this  $I_{co}$  in germanium transistors was extremely sensitive to temperature variations.

The difference between the  $I_{co}$  values for germanium and silicon might be any ratio between the ratios of 100 to 1 and 500 to 1. The rate of increase in  $I_{co}$  with temperature is about equal for both types of transistors; but since the value of  $I_{co}$  for silicon is so extremely small at room temperature, the unit can be used at much higher temperatures before this factor becomes troublesome.

Another characteristic in which silicon excels is in its collector resistance  $R_c$ . This value is higher than the comparable collector re-

sistance of germanium transistors. As we raise the operating temperature, the  $R_c$  in both types of transistors will decrease; but since  $R_c$  is higher (at room temperature) in silicon than in germanium, the silicon transistor can be used at higher temperatures without too much decrease of  $R_c$ . When the behavior of  $I_{co}$  and  $R_c$  are considered, it is seen why silicon transistors possess higher maximum dissipation ratings and why they are useful as high as 150 degrees centigrade.

Current and power gains of silicon units are each lower than they are for corresponding germanium transistors. The mobility of electrons in silicon is about one fourth that of germanium and therefore tends to impair the frequency response of silicon transistors; however, there are other factors that have to be taken into consideration. For example, collector capacitance  $C_c$  is a very important determining factor (as we have already seen); and in silicon units, this value is much lower than in germanium transistors. Another compensating factor is that higher collector voltages may be employed with silicon transistors. This serves to decrease the effective value of  $C_c$  further, and the frequency response is therefore improved.

At the present time, most of the silicon transistors commercially available are of the n-p-n variety and are fabricated by the grown-junction process. Work is progressing on diffused-junction units; and if suitable mass-production techniques can be developed, diffused-junction transistors will probably be more widely used. Transistors produced by the latter method possess certain advantages over the grown-junction units; these include lower base resistances, greater electrical symmetry for use in two-way (bilateral) applications, and a higher reverse emitter-breakdown voltage. Furthermore, the diffused-junction process yields more transistors than the grown-junction process, if the same amount of pure silicon crystal is used.

by MILTON S. KIVER

## STACKPOLE RESISTOR DISTRIBUTORS

**ALBANY, N. Y.**  
E. E. Taylor Co.

**ALLENTOWN, PA.**  
Federated Purchaser

**BALTIMORE, MD.**  
Kann-Ellert Electronics Inc.

**BINGHAMTON, N. Y.**  
Morris Distributing Co., Inc.

**BOSTON, MASS.**  
DeMambro Radio Supply

**BUFFALO, N. Y.**  
Radio Equipment Corp.

**CANTON, O.**  
Video Wholesalers Inc.

**CEDAR RAPIDS, IOWA**  
Gifford-Brown Inc.

**CLEVELAND, O.**  
Pioneer Electronic Supply Co.

**COLUMBUS, O.**  
Hughes-Peters Inc.

**DALLAS, TEXAS**  
Wholesale Electronic Supply

**DAYTON, O.**  
Srepco Inc.

**DES MOINES, IOWA**  
Radio Trade Supply Co.

**HAGERSTOWN, MD.**  
Zimmerman Wholesalers

**HARTFORD, CONN.**  
R. G. Sceli & Co., Inc.

**HAZLETON, PA.**  
Moyer Electronic Supply Co., Inc.

**JAMAICA, N. Y.**  
Norman Radio Distributors Inc.

**KANSAS CITY, MO.**  
Burststein Applebee Co.

**LAFAYETTE, LA.**  
Rolphs Radio Electronic Supply

**LANSING, MICH.**  
Offenhauer Co.

**MANSFIELD, O.**  
Wholesaling Inc.

**McKEESPORT, PA.**  
Barno Radio Co.

**MILWAUKEE, WISC.**  
Radio Parts Co., Inc.

**MOUNTAINSIDE, N. J.**  
Federated Purchaser

**NEWTON, MASS.**  
Leonard Greene Shaw Co.

**NEW YORK, N. Y.**  
Arrow Electronics Inc.

**NEW YORK, N. Y.**  
Electronics Center

**NORFOLK, VA.**  
Radio Equipment Co.

**OAK PARK, ILL.**  
Melvin Electronics Inc.

**PASADENA, CAL.**  
Electronic Supply Corp.

**PHILADELPHIA, PA.**  
Almo Radio Co.

**RICHMOND, VA.**  
Meridian Electronic Equipment Co.

**SAGINAW, MICH.**  
Saginaw Distributors Inc.

**ST. LOUIS, MO.**  
Van Sickinge Radio Corp.

**SCRANTON, PA.**  
Fred P. Pursell

**SPRINGFIELD, ILL.**  
Suter TV Supply Inc.

**SPRINGFIELD, MASS.**  
Soundco Electronic Supply Co.

**SYRACUSE, N. Y.**  
Morris Distributing Co., Inc.

**TAMPA, FLA.**  
Thurow Distributors Inc.

**TRENTON, N. J.**  
The Dragon Co.

**TUCSON, ARIZ.**  
Elliot Electronics Inc.

**WASHINGTON, D. C.**  
Electronic Wholesalers Inc.

**WATERBURY, CONN.**  
Bond Radio Supply

**WICHITA, KAN.**  
Interstate Electronic Supply Corp.



# STACKPOLE FIXED COMPOSITION RESISTORS

more  
than match  
today's exacting  
requirements

(INCLUDING MIL-R11 SPECIFICATIONS)

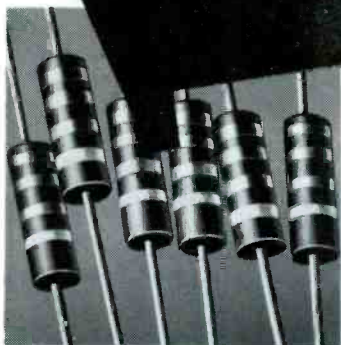

1 Watt  
Type CM-1

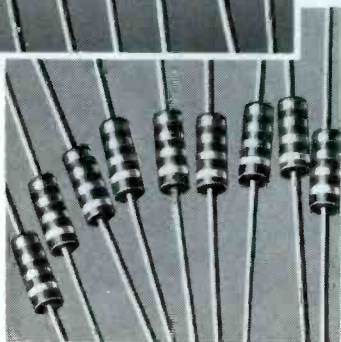

1/2 Watt  
Type CM-1/32

... and they're the easiest-to-solder resistors on the market!

- ✓ Rated at 70°C. ambient
- ✓ Unsurpassed for humidity protection
- ✓ Low noise level

## WHAT WELL-DRESSED RADIOS "WORE" IN 1928

This old sample kit displays the complete line of Stackpole fixed and variable resistors and spark plug suppressors made almost 30 years ago. Today, Stackpole resistors in vastly improved types are one of the two most widely used brands.



Distributors' Division  
**STACKPOLE CARBON COMPANY**  
26 Rittenhouse Place • Ardmore, Pa.

**PROMPT DELIVERIES**  
**FROM THESE LOCAL  
DISTRIBUTORS**



# Only PRECISION hi-fi changer ever priced so low!

HERE'S YOUR CHANCE to grab the hi-fi changer market in your neighborhood! Voice of Music 1200 is priced right . . . performs right—and it's profit-right too!

V-M MODEL 1200  
4-SPEED  
RECORD CHANGER

**\$4650\***  
(LIST)

*\*Slightly higher in the west.*

See What you sell!



FEATHER-WEIGHT  
DIE CAST  
ALUMINUM  
TONE ARM

NEW DIRECT-DRIVE  
4-SPEED  
MECHANISM

NEW  
LOW-TORQUE  
MECHANISM  
FOR TWICE THE  
LIFE, HALF THE  
WEAR

ALL-WEATHER  
DUAL SAPPHIRE  
NEEDLE  
CERAMIC  
CARTRIDGE

'EASY-LIFT'  
RECORD  
SUPPORT ARM  
FOR  
FRONT-LOADING  
CONVENIENCE

V-M  
TRI-O-MATIC<sup>®</sup>  
SPINDLE  
ELIMINATES  
HOLDERS THAT  
GRIP RECORD  
GROOVES

MANUAL  
OPERATION  
WHEN DESIRED

AUTOMATIC  
SET-DOWN FOR  
7", 10" AND 12"  
RECORDS

See your V-M Distributor Salesman . . . get full particulars—then, place your order! Watch hi-fi changer sales pick up—but fast!

V-M CORPORATION, Benton Harbor 7, Mich.  
WORLD'S LARGEST MANUFACTURER OF  
PHONOGRAPHS AND RECORD CHANGERS

the **Voice**  of **Music** <sup>®</sup>

## Brakes and Tape Tension

(Continued from page 19)

### Magnetic Brakes

Magnetic brakes are used in the DeJur Recorder TK820 which is shown in Fig. 4. No mechanical arms or pivots are used in this arrangement. Braking action is accomplished by means of selective clutches and magnetic action when certain switches are thrown and certain relays are actuated.

The reel turntables (of ivory-colored plastic) are each composed of two major parts which we will call the upper and lower parts. The lower part is turned by a belt which is driven by a pulley mounted on a selective clutch assembly. Another pulley is located directly under the upper pulley (visible in Fig. 4) on the clutch assembly. These lower pulleys are turned by separate belts that are driven by separate pulleys on the shaft of the single motor used in the TK820 recorder. The lower pulleys are turned in the same direction when the motor is running, but only one reel turntable can turn because the selective clutch associated with the other one will not permit it to turn. The top pulley and the turntable on the left can turn only in a clockwise direction because the selective clutch locks the upper pulley when it tries to rotate in a coun-

terclockwise direction. The turntable on the right can rotate only in the counterclockwise direction because of a similar arrangement.

Each reel turntable operates in the same manner, and they are similar because the TK820 is a dual-track recorder designed to record and playback in both directions of tape travel; consequently, each reel operates as the supply or take-up reel, depending upon which direction the tape is moving. When we describe the action of one turntable, we are therefore describing the other one also.

The top part of the reel turntable is held in place on the lower part by its own weight. A metal clip secured to the frame of the recorder with a single machine screw serves as a stop which does not permit the top part to be lifted off the lower part. In Fig. 4, the clip has been removed and the top section of the turntable assembly has been stood on edge to reveal the simple construction of the brake.

The metal parts and the coil constitute the magnetic structure. Current to energize the electromagnet is fed to the coil by two leads which run up through the shaft on which the turntable revolves. The iron disc under the coil is drawn up against the rubber ring, which is on the upper part, when current flows through the coil. Since the iron disc cannot turn on the shaft but has to

turn with the lower part of the assembly, the top portion of the assembly also has to turn when the two parts are locked together by the magnetic action.

When no current is flowing through the coil, a certain amount of coupling is still maintained between the two sections because of the friction created by the felt ring. The drag of the felt ring produces tape tension if the lower portion of the turntable is locked by the selective clutch so that it cannot turn in the direction in which the tape is traveling. If the magnet is energized while the lower portion of the turntable assembly is locked, the upper part will be clamped tightly to the motionless lower part. Very positive braking action is achieved in this way.

When the operating mode requires that power be applied to the reel to wind the tape (such as in the rewind mode), the upper part of the turntable is clamped to the revolving lower portion by the magnetic action.

The details on the magnetic brakes used in the DeJur Model TK820 recorder have been given here because some knowledge of how such systems are constructed and how and why they operate is certainly useful when any testing, adjusting, or servicing is required. Although very little trouble should ever be experienced with a system such as this one, the very nature of the trouble should give clues as to where it originates if any should occur. At least, it should give clues if we are acquainted with the operation of the mechanism.

For example, if a turntable should slip or stick, it would seem logical to examine the felt ring to see if the ring has become contaminated with oil, grease, or some other foreign substance. Or, if the brakes do not operate, maybe a coil is open or the contacts on a relay or switch are dirty and do not complete the circuit. A quick check should give the answers.

### Dynamic Brakes

Dynamic braking is employed in some recorders that use separate motors to drive the rewind

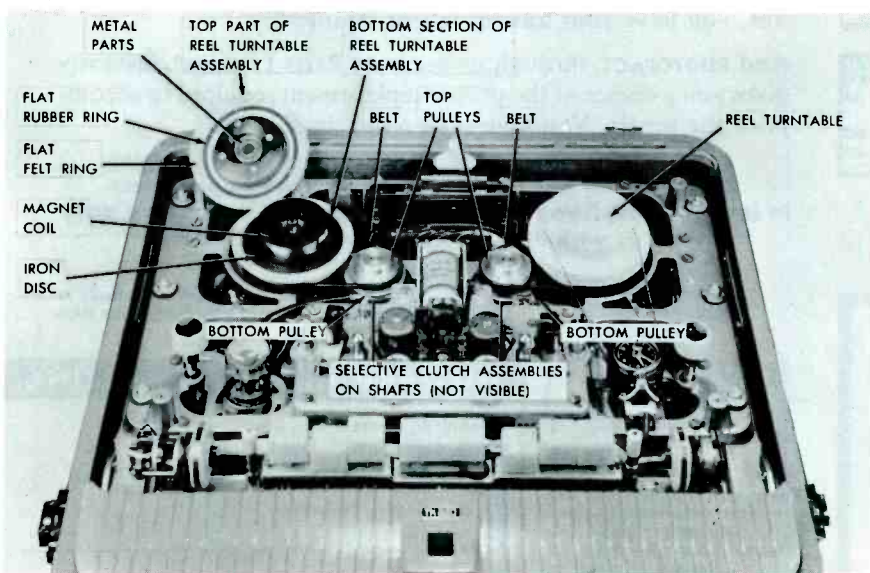
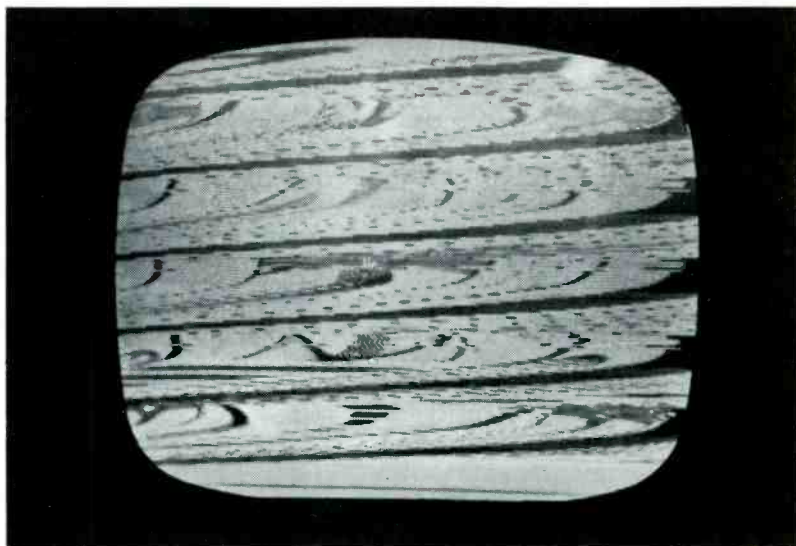

Fig. 4. Magnetic Brakes Used in DeJur Model TK820 Tape Recorder.

# how long would it take you to solve this service problem?

**SYMPTOM:**  
 Loss of horizontal hold. Hold control will not pull the picture into synchronization. Sound is normal.



**There's no telling how long it might take to solve this problem with hit-or-miss methods—it's been known to take hours. With a PHOTOFACT Folder by your side, the job takes just minutes. Here's why:**

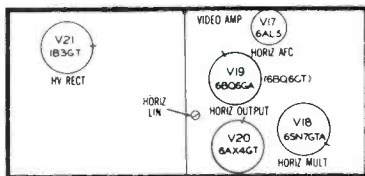

In just seconds, you locate the tubes most likely to cause this symptom by referring to the Tube Placement Chart\* and Tube Failure Check Chart\* you'll always find in the same place in each PHOTOFACT Folder.

*In this case the trouble wasn't caused by tube failure, so...*

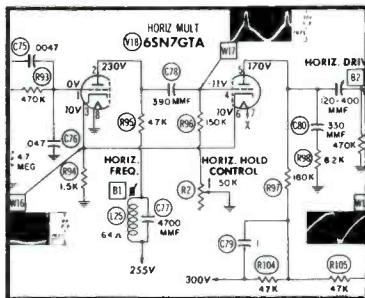

In just seconds you refer to the Horizontal Circuit on the Standard Notation Schematic\* featured exclusively in all PHOTOFACT Folders. Circuits are always laid out in the same uniform manner. The Horizontal Circuit is always located in the lower center of the schematic. In a matter of minutes you check waveforms and voltages—they're right on the schematic. And in those same few minutes you find the answer to the problem in this case history. The waveform at W17 and the voltage reading at Pin 4 show a leaky coupling capacitor C78. Yes, you have your answer in just minutes!

C74	270	500	RCM20A271K	SI270	D6-27
C75	.0047	400	RCP10M4472M	SI4700	D6-47
C76	.047	200	RCP10M2473M	BPD-05	DF-50
C77	4700	500	47X543	1464-0047	
C78	390	500	RCM20B391J	1469-00039	D6-39
C79	.1	400	RCP10M4104M	P488N-1	DF-10
C80	330	500	47X570	1469-00033	D6-33

And PHOTOFACT, through its accurate Parts Listings\*, instantly gives you a choice of the proper replacement required to accomplish the repair. You save even more time!

**From start to finish, you solve your service problems in just minutes...you service more sets and earn more daily with PHOTOFACT by your side!**

\*One of 32 features found exclusively in PHOTOFACT—the world's finest service data

**MONEY BACK GUARANTEE!**

Got a tough repair? Try this—at Howard W. Sams' own risk: see your Parts Distributor and buy the proper PHOTOFACT Folder Set covering the receiver. Then use it on the actual repair. If PHOTOFACT doesn't save you time, doesn't make the job easier and more profitable for you, Howard W. Sams wants you to return the complete Folder Set direct to him and he'll refund your purchase price promptly. **GET THE PROOF FOR YOURSELF—TRY PHOTOFACT NOW!**

**free** 

Send for Sams' INDEX TO PHOTOFACT FOLDERS—your guide to virtually any receiver model ever to come into your shop; helps you locate the proper PHOTOFACT Folder you need to solve any service problem on any model. You'll want this valuable reference guide. Send coupon now.

**HOWARD W. SAMS & CO., INC.**  
 Howard W. Sams & Co., Inc.  
 2201 E. 46th St., Indianapolis 5, Ind.

Send FREE Index to PHOTOFACT Folders  
 I am a Service Technician

Name \_\_\_\_\_  
 Address \_\_\_\_\_  
 City \_\_\_\_\_ Zone \_\_\_\_\_ State \_\_\_\_\_

and take-up reels. For example, to stop the rewind and take-up motors in the TDC Stereotone Model 130 tape recorder, the AC supply is removed from the fields of the motors involved and DC is applied. Needless to say, the motors are stopped and locked at once by the stationary field.

If the brakes of the Model 130 recorder should fail, one of the first things to check would be the selenium rectifier which supplies the DC used to stop the motors.

Reference to service literature covering a particular tape recorder should be made whenever any adjustment of tape tension or repair of brakes is performed. The recommendations for one recorder will not necessarily apply for another recorder of a different make or model. For example, most manufacturers warn that no oil, grease, nor lubricating material be applied to the braking surfaces because, if the brakes are contaminated by such materials, the drums will have to be cleaned and the lining replaced before normal operation can be restored. On the other hand, we have known of a couple of instances when manufacturers have supplied a lubricant to be applied to the felt brake pads to soften the braking action and prevent grabbing. This illustrates the reason that service literature should be consulted.

When the felt pads or lining of the brake shoes or bands become contaminated or worn to the extent that their operation is affected, they should be replaced with the replacements supplied by the manufacturer. A good grade of wool felt can be used in an emergency; but since the quality of the felt is important, these improvised linings should be replaced as soon as possible with factory replacements. Some felts are not suitable for use as brake-lining material because of their plastic content. Such felts have a tendency to melt or burn when subjected to braking pressures.

The brakes of tape recorders are very important and do a lot of work; but if they are adjusted properly, they will operate satisfactorily for long periods of use.

by ROBERT B. DUNHAM

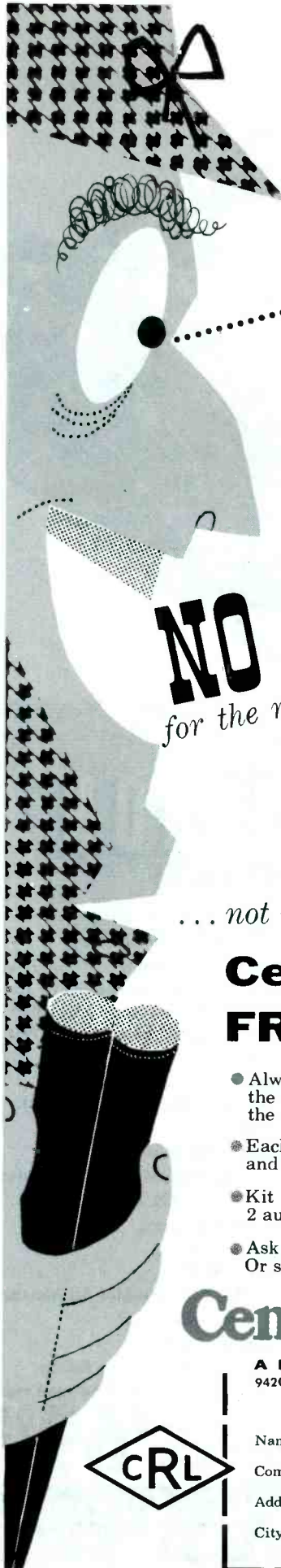

**\$23.50**  
including  
sturdy metal  
cabinet  
Suggested  
net price

**NO HUNTING**  
for the right dual-control replacement

... not if you have a

**Centralab Fastatch<sup>®</sup>  
FR-22A Kit**

- Always handy, right at your fingertips — the dual-concentric replacements you need 80% of the time, for all popular TV, radio, and auto sets.
- Each control is factory assembled, tested, and guaranteed.
- Kit contains 22 control units, 4 Fastatch switches, 2 auto adapter bushings.
- Ask your Centralab distributor to tell you more. Or send coupon for bulletin 42-223.

**Centralab**

A DIVISION OF GLOBE-UNION INC.  
942C East Keefe Avenue, Milwaukee 1, Wisconsin

Send me Fastatch bulletin 42-223

Name.....  
Company.....  
Address.....  
City..... Zone..... State.....



# NEW



## PHASTRON

NONE FINER

# 777

V. T. V. M.

(VACUUM TUBE VOLTMETER)

YOUR KEY TO EXCELLENCE



The MODEL "777" V.T.V.M. is a completely self-contained, ready-to-use test instrument. Its accessories and the HF co-ax cable, DC Probe, AC line cord and instruction book all fit in the genuine California Saddle Leather carrying case that is furnished with the instrument.

- 42 Unduplicated Ranges
- Illuminated Dial (5000 hour self-contained lamps)
- Die Cast Chrome Finished Bezel
- Metal Case, unbreakable, ultra compact
- Doubly Shielded, time proven 200 microamp movement
- Permanent Accuracy . . . 3% DC, 5% AC
- Large, Easy to Read Scales 4 1/4" Long
- Color Coded Scales: green—ohms; black—AC, DC; Red—P. to P.
- 2 Zero Center Scales for FM Discriminator Alignment
- Separate Range and Function Switches
- Only 2 Jacks for All Measurements
- New, High Style, Easy-to-Use Chrome Bar Knobs
- Dual Purpose Handle also serves as AC line cord reel

"777" V.T.V.M. complete with Coaxial Cable, DC Probes and Leather Case at your PARTS DISTRIBUTOR

# \$69<sup>95</sup>

### PHASTRON COMPANY

151 PASADENA AVE. • SOUTH PASADENA, CALIF.

## Notes on Test Equipment

(Continued from page 21)

R1 and R2 act as a voltage divider to the input signal  $E_{input}$ . When  $C_c$  is adjusted to a value so that the product of R1 times  $C_c$  will equal R2 times  $C_{in}$ , the division ratio will not vary with a variation of frequency.

Although the input impedance of most oscilloscopes is fairly high, it may sometimes load high-impedance circuits to which the oscilloscope is connected. We can reduce this effect by simply inserting a high resistance in series with the oscilloscope leads. By so doing, we also reduce the signal to the first amplifier stage of the oscilloscope; but the gain of most oscilloscopes is usually sufficient to overcome this reduction.

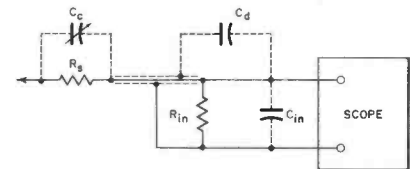

Fig. 5. The Addition of a Low-Capacitance Probe to the Input Circuit of an Oscilloscope.

The new circuit, with series resistor  $R_s$  and shielded input cable, is shown in Fig. 5. The shielded cable has its own distributed capacity, and this capacity may be as much as 150 micromicrofarads in the short length commonly used for a test lead. In Fig. 5,  $R_{in}$  is the total input resistance (attenuator and grid resistance) of the oscilloscope and  $C_{in}$  is the total input capacitance. The distributed capacity of the cable is  $C_d$ , and it can be seen that this capacity is shunted across the input of the oscilloscope and upsets the frequency balance obtained by the compensated network of Fig. 4. The balance can be restored by the addition of a trimmer of proper value for capacity  $C_c$ .

With the addition of  $C_c$  to Fig. 5, the circuit is similar to that of Fig. 4 and can be adjusted in the same manner. The trimmer is properly adjusted when:

$$R_s + C_c = R_{in} (C_{in} + C_d).$$

In commercial equipment, capacitor  $C_c$  and resistor  $R_s$  are assembled into a probe and are shielded for minimum hum pick-up. A small hole is usually left in the probe shield so that trimmer  $C_c$  can be adjusted for best operation with the particular oscilloscope being used.

### Adjusting the Probe

One of the best and easiest methods of adjusting a probe requires the use of a square-wave generator. The signal from this generator is fed through the probe to the oscilloscope, and the waveform is observed while the adjustment is being made. When  $C_c$  is properly adjusted, the waveform will be a perfect square wave. The top and bottom of the wave will be perfectly parallel, as in Fig. 6A. Fig. 6B shows the waveform when  $C_c$  is too large, and Fig. 6C shows the waveform when  $C_c$  is too small. It need hardly be mentioned that the response will be a perfect square wave only if the response characteristics of the oscilloscope are adequate.

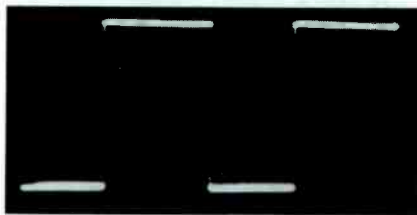

(A) Correct Adjustment.

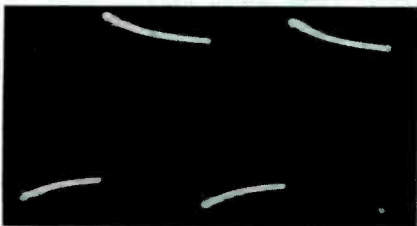

(B)  $C_c$  Too Large.

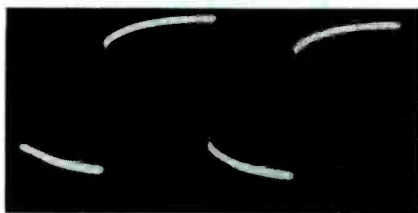

(C)  $C_c$  Too Small.

Fig. 6. Square Wave Used in Adjusting a Low-Capacitance Probe.



**20¢**  
net price

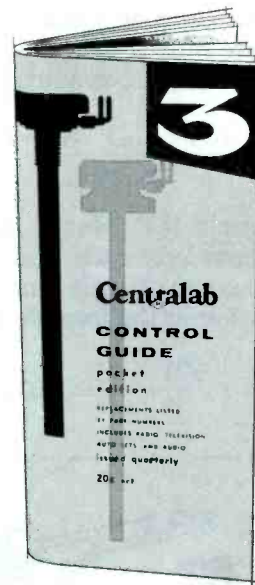

# NO GUESSING

*about which control replacement to use*

## Centralab Control Guide

*has the answers*

- Lists Centralab replacements by manufacturers' part numbers — for TV, radio, audio, auto radio.
- Always up to date — revised quarterly.
- Handy pocket size, 3 3/4" x 8 1/4".
- Order a copy for yourself and each of your men.
- Get from your Centralab distributor — or order direct by coupon below.

## Centralab

A DIVISION OF GLOBE-UNION INC.  
942C East Keefe Avenue, Milwaukee 1, Wisconsin

- Enclosed is \$1.00 for the next five editions of the Centralab Pocket Control Guide.
- Enclosed is 20¢ for current edition only. (Paste coins securely to cardboard.)

Name \_\_\_\_\_  
Address \_\_\_\_\_  
City \_\_\_\_\_ Zone \_\_\_\_\_ State \_\_\_\_\_

B-5615



The duration of a half cycle of the square wave used should compare to the time constant:

$$T = \frac{(C_d + C_{in})(R_s R_{in})}{R_s + R_{in}}$$

For example, if  $C_d$  plus  $C_{in}$  equals 100 micromicrofarads and if  $R_s$  and  $R_{in}$  equal 2 megohms each, substitution in the formula gives:

$$T = \frac{.0001 \times 4}{2} = .0002.$$

This is .0002 second for a half cycle of the square wave or .0004 for a whole cycle. The time corresponds to a frequency of 2.5 kilocycles per second. This frequency need not be exact, and any frequency close to this should give good results.

In the absence of a square-wave generator, the technician can adjust his probe by using the video signal obtained at some point in a TV receiver. The horizontal and vertical sync pulses of

this signal are very good substitutes for square waves, and the fact that they differ widely in frequency is the basis for this method. The video signal should be

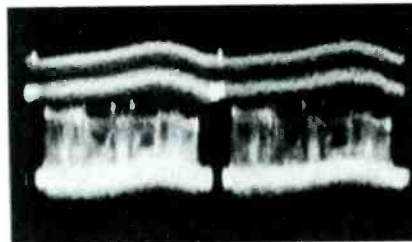

(A) Correct Adjustment.

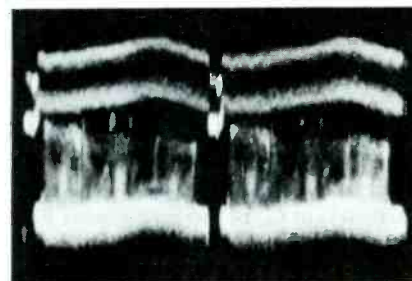

(B)  $C_c$  Too Large.

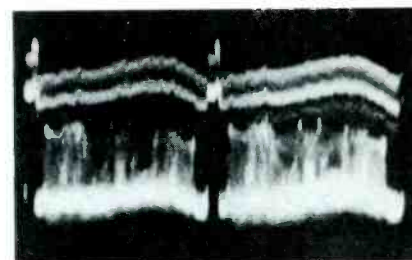

(C)  $C_c$  Too Small.

Fig. 7. Video Signal Used in Adjusting a Low-Capacitance Probe.

fed through the probe to the oscilloscope. The oscilloscope is synchronized to the frequency of the vertical sync pulses, and the waveform will appear as in Figs. 7A, B, or C. As the trimmer is adjusted, the level of the horizontal sync pulses will shift with respect to the level of the vertical sync pulse. The correct adjustment is obtained when both the horizontal and vertical sync pulses are on the same level, as in Fig. 7A. This method may not be as accurate as the first method, but it is practical when the technician does not have access to a square-wave generator.

by PAUL C. SMITH

PF REPORTER • March, 1956



ALL FOR  
**\$7.95**  
list

Weller Soldering Gun—Model 8100, a \$7.95 value

Wire-bristle Soldering Brush for cleaning connections—streamlined for getting into tight places

Famous Kester Solder—generous supply

Soldering Aid for opening old joints, holding down and twisting wires—nothing handier!

**FIRST AGAIN!** Yes, Weller WAS first to invent...first to patent...first to sell. And today Weller IS first in sales...first in features...first in value.

**MODEL 8100 WELLER GUN**

**Soldering hot in 5 seconds!**

Over 100 watts—ample power for normal service  
• Perfect hand-balance grip • Dual spotlights light up work • Triggermatic control—instant "on-off" heat • Streamlined design for maximum reach • Long-life Wellertips.

SEE THIS BIG SOLDERING TOOL VALUE. ASK YOUR DISTRIBUTOR FOR A DEMONSTRATION... OR WRITE DIRECT FOR CATALOG BULLETIN

**Weller**

**ELECTRIC CORPORATION**  
Easton, Pennsylvania



## Audio Facts

(Continued from page 25)

signals from the front and from the rear but are insensitive to signals that come from the sides. When using a bidirectional microphone, the user picks up the desired signal by pointing the "live" front or back of the microphone toward the signal source. Unwanted sounds are rejected by turning a "dead" side toward them.

This brings up the subject of correct microphone placement which we will have to discuss later when the opportunity presents itself.

### Unidirectional and Cardioid

Unidirectional and cardioid microphones are designed and constructed in such a manner that they are sensitive only to sounds that originate in front of them. Such microphones are used wherever sound is to be picked up from some certain source and whenever unwanted sounds in the vicinity must be rejected. If these very directional microphones were not available, it would be practically impossible to obtain satisfactory pickup of the desired signal under certain conditions often encountered in PA, broadcasting, and recording work.

The term cardioid is derived from the heart-shaped pattern obtained when the directional characteristics of a unidirectional microphone are plotted on a polar graph. The resulting curve is similar to the mathematical cardioid figure.

### Differential

The differential microphone has very directional characteristics in that it is capable of selecting the desired signal out of surrounding noises and sounds that may even be coming from the same direction as the desired signal. Its action depends somewhat upon the proximity of the signal to the correct point on the microphone. Hand-held communications microphones used in very noisy locations are usually differential units.

We have mentioned that microphones must be designed and constructed purposely for certain

## Short description of a Small Efficient TV System...

**1 antenna .. IN**  
**8 set lines .. OUT**  
**10 db signal .. GAIN**

all with  
the



**DISTRIBUTION  
AMPLIFIER**

model DA8-B

approved  
for  
Color-TV

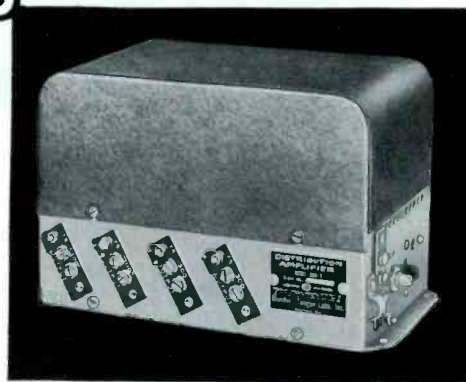

**\$89<sup>50</sup> List**

Ideal for garden apartments, motels, TV showrooms, deluxe home installations and other small TV systems. The DA8-B is a broadband, all-channel unit that requires no tuning, impedance matching devices, preamps or other special fittings.

### Features and Specifications:

- Low noise all-triode circuit
- More than 10db gain on all VHF Channels
- Inter-set isolation in excess of 22db
- Provision for 75-ohm cable or 300-ohm twin lead
- Prevents overload through 10:1 gain control range
- Built-in power supply
- Designed for continuous duty operation

NOTE: For larger systems, Blonder-Tongue will furnish Free planning service on request.

Sold by Radio-TV Parts Distributors and Jobbers.

Write for Installation Details and FREE Booklet—"TV for 2 . or 3 . or More"

Dept. KC-13

**BLONDER-TONGUE  
LABORATORIES, INC.**

Westfield, New Jersey

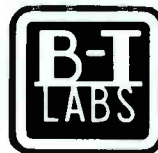

Manufacturers of TV Cameras,  
TV Amplifiers, Boosters, Converters,  
Accessories and Originators of the  
Masterline and 'Add-A-Unit'  
Master TV Systems.

directional characteristics. The methods used to accomplish the desired results are very interesting; but before going into any discussion concerning them, we will say some more about directional-characteristic graphs.

### Polar Graphs Showing Directional Characteristics

Some readers may be prejudiced against graphs of any kind; but if any data regarding the directional characteristics of a mi-

crophone is examined, at least one polar graph will usually be encountered. Graphs are included in the data because they tell the story very clearly and show the relative strength of the signal picked up from any and all directions around the microphone.

We are looking down on the top of the microphone in the center of the graph of Fig. 1, and the relative strength of the signal developed by the microphone as it responds to sound that is of a

constant level and originates from every angle around it is shown by the graph. This is a graph for a nondirectional microphone; therefore, the curve is in the form of a circle because the microphone presents the same sensitivity to sounds originating from every direction in the full 360 degrees around it.

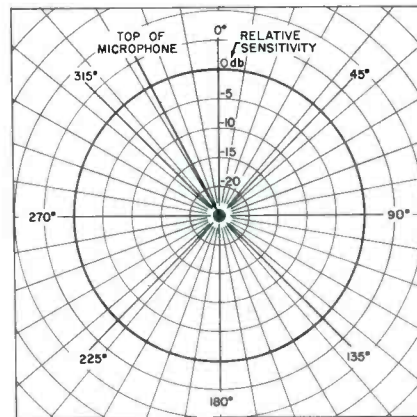

Fig. 1. Polar Graph Showing Directional Characteristics of Omnidirectional Microphone. (Viewed from above top of microphone.)

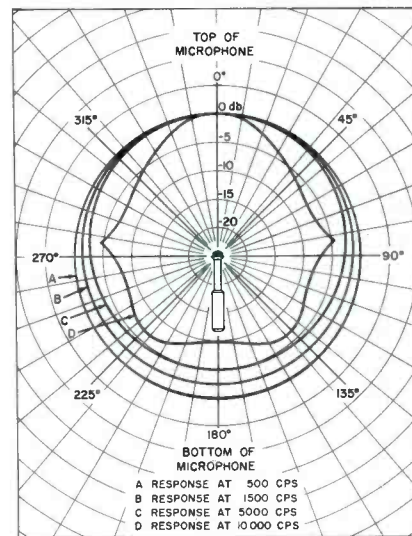

Fig. 2. Directional Pattern of Omnidirectional Microphone. (Viewed from side of microphone.)

Graphs are usually shown in the plane diagrammed in Fig. 1. A graph showing the directional characteristics of the same microphone but in another plane is shown in Fig. 2. In this figure, the directional pattern is drawn as viewed from the side of the microphone. This graph illustrates that this particular microphone becomes somewhat directional at high frequencies.

Sensational! The NEW...

# VACO<sup>®</sup>

## Hollow Shaft NUT DRIVERS in Color

Nothing else like them anywhere! Choice of 28 types and sizes! New plastic kit at right contains 7 most popular drivers in self-standing bag for service work or bench use.

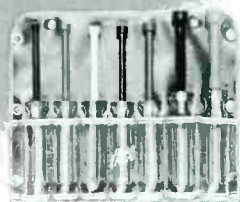

No. K7 Self-Standing Service Kit  
Stands Up! Hangs Up! Folds Up!

Stands upright for easy accessibility. May be hung flat on wall or may be folded. Each driver fits in individual holder marked for size, color.

### Check These 6 Important VACO Features

NEW! Each size color-keyed!

NEW! All-hollow shafts

NEW! Extra large VACO Comfordome Handles!

NEW! Extra hard long wearing sockets!

NEW! Shafts insulated from handle to tip!

NEW! Available in 4 shaft lengths and 7 Hex sizes!



**THIS COUPON WORTH \$1.20**

Name..... P. F.  
Street.....  
City..... Zone..... State.....

**VACO PRODUCTS COMPANY**  
317 E. Ontario St., Chicago 11, Ill.  
In Canada: Vaco-Lynn Products Co., Ltd., Montreal 1, Que.

Coupon only valid for use as stated below. Not valid in states where prohibited.

Take this coupon to your jobber. It is worth \$1.20 when filled in and used to purchase one VACO K7 Kit. If your jobber cannot supply you, write direct.

The polar graph in Fig. 3 illustrates the directional characteristics of a bidirectional microphone. The dead areas at the sides of the microphone and the sensitive areas at the front and back are indicated very clearly.

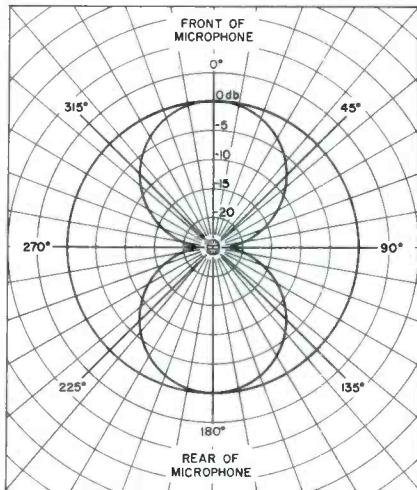

Fig. 3. Directional Pattern of Bidirectional Microphone. (Viewed from top of microphone.)

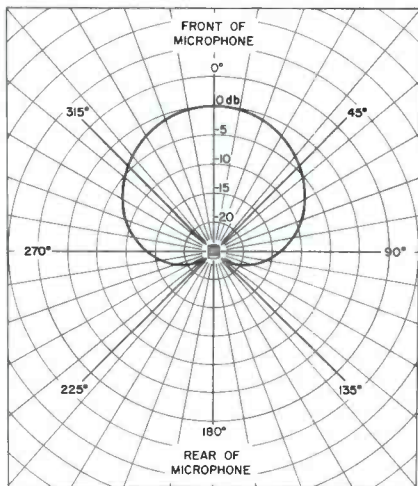

Fig. 4. Directional Pattern of Unidirectional or Cardioid Microphone. (Viewed from top of microphone.)

Fig. 4 is a typical graph of the characteristics of a unidirectional or cardioid microphone. We say typical because this directional pattern varies with unidirectional microphones made by different manufacturers. The width of the directional pattern varies because each manufacturer produces unidirectional and cardioid microphones according to his own design that features certain special modifications.

Space has been devoted to the

# WIN-TRONIX

## Makes Sweep and Sync Circuit Trouble-Shooting Easy! **LOW-COST DYNAMIC SWEEP CIRCUIT ANALYZER**

for  
Black-and-White TV  
and color too!

only

**\$69<sup>95</sup>**

dealer net

Model 820



TWO  
INSTRUMENTS  
IN ONE

1. Horizontal and vertical sawtooth-square wave and sync pulse generator.
2. Complete compatible flyback and yoke tester.

### ISOLATE SWEEP/SYNC TROUBLES RAPIDLY IN FIVE EASY STEPS!!!

1. VERTICAL TROUBLESHOOTING  
Inject 60 cps on vertical output grid from "vertical grid drive" jack.



2. HORIZONTAL TROUBLESHOOTING  
Inject 15,734 cps on horizontal output grid from "horizontal grid drive" jack.



3. HORIZONTAL TROUBLESHOOTING  
Drive horizontal output xfmr directly from "xfmr drive" jack.



4. COMPONENT TESTING  
Test flyback transformer and deflection yoke in receiver with Model 820.

5. SYNC CIRCUIT TROUBLESHOOTING  
Inject vertical and horizontal sync pulses, stage by stage, in sync amplifiers, with accessory probes.

#### SPECIFICATIONS

Signal Outputs  
15,734 cps sawtooth and pulse adjustable.  
15,734 square wave adjustable.  
60 cps sawtooth locked to line.  
Overload indicator for safety and test.  
Oscillating neon indicator with D.C. amplifier for flyback/yoke test.  
Calibrated for color and black-and-white.  
Test leads supplied.  
Operates on 105-125 VAC.

### OTHER WIN-TRONIX LOW-COST TV TEST INSTRUMENTS— Buy Now for Bl. & Wh. Service—be ready for color!

WHITE DOT—Linearity  
Generator



Model  
160

**\$79.95**

RAINBOW GENERATOR



Model  
150

Patent Pending **\$49.95**

COMPATIBLE FIELD  
STRENGTH METER

Model  
330

**\$129.95**



FLYBACK AND YOKE  
TESTER

Model  
810



**\$29.95**

- Compatible advanced design prevents obsolescence!
- Low cost with high quality!
- Portability!
- Standard warranty on all instruments!

SEE YOUR PARTS JOBBER!  
WRITE FOR FREE LITERATURE!

COMPATIBLE CRYSTAL  
CALIBRATOR



Model  
120

**\$59.95**

## WINSTON ELECTRONICS, INC.

Dept. PF 1255

4312 Main St., Philadelphia 27, Pa.

foregoing because we feel that it is worth while to give some idea of the various directional microphones that are available and also to furnish some explanation of the terms used to describe them. They are only part of the story. The practical and interesting parts concerning the ways and reasons that the microphones with different directional characteristics should be used and the methods used to make the microphones directional have not been

discussed. Complete coverage of these subjects would more than fill a book, but we will try to cover as many interesting points as possible.

No particular problem should be encountered when a nondirectional microphone is used in a situation in which the microphone must pick up sound from all sides. For example, during the recording of a conference or discussion when the participants are seated around a table, a nondirectional

microphone placed in the center of the table will pick up the conversation originating from any point around the table.

Nondirectional microphones are usually crystal, dynamic, or condenser types that have been modified to obtain the desired directional characteristics. For best results, the microphone should be small in comparison to the wavelength of the signals which it will pick up. If it is large, the diffraction effect will cause the higher frequencies to be deflected and fail to register with full effect when they strike the microphone from any angle other than directly into the diaphragm.

you've got to **Spend** money  
to **Save** time and money

Time lost on the job or in the shop means money out of your pocket. That's why it will pay you to choose BUD Test Leads and Prods that can be assembled in seconds rather than minutes. All Bud products are engineered and built with quality and value as the vital factor. Don't waste your time and money on poor quality . . . insist on Bud Test Leads and Prods.

#### SUPER TEST LEADS

With vise-grip prods that screw into the plastic handles, eliminating the use of soldering iron or screw driver to replace broken or worn lead. Time is your most expensive commodity. This is where top quality pays off. Only the finest flexible, kinkless rubber covered wire is used.

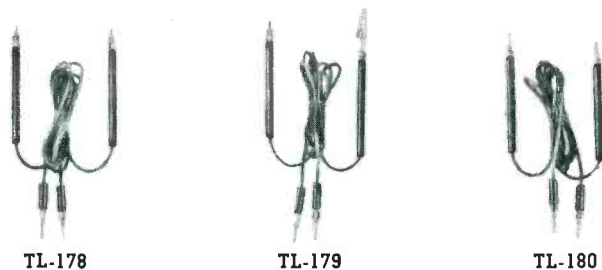

- TL-178** — 4" handles at one end of the wires with removable needle points and 1" handle with phone tips on other end. Dealer Net. \$1.35.
- TL-179** — 4" handles, one with removable needle point and other with phone tip and removable alligator clip. 1" handles have phone tips. Dealer Net. \$1.35.
- TL-180** — 4" handles with phone tips on one end. 1" handles have phone tips also. Dealer Net. \$1.20.

#### TEST PRODS WITH PLASTIC HANDLES

Made of brass rod, nickel plated. Have plastic handles and feature the vise-grip method of assembly for speed and efficiency of wire replacement.



If your local Bud distributor does not have Bud Test Leads or Prods, send us his name together with your name and address. Enclose 25¢ for handling and mailing. Upon verification we'll send you a sample pair of Test Leads.

**BUD RADIO, INC.**

2118 East 55th St. • Dept. X • Cleveland 3, Ohio

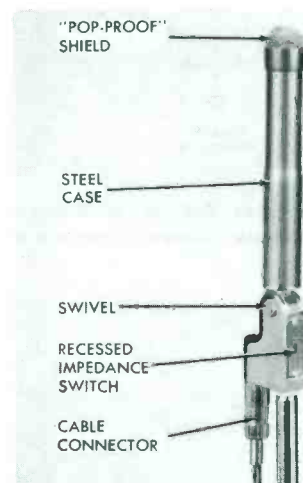

Fig. 5. Electro-Voice Model 654 Microphone.

The Electro-Voice Model 654 dynamic microphone (Fig. 5) is an example of an omnidirectional microphone. The polar graphs in Figs. 1 and 2 show the directional characteristics for the Model 654 microphone. The dimensions of what we might call the active part of the microphone are reasonably small. The diaphragm is located in the top end of the case and faces upward. In this position, the diaphragm is equally accessible to sound originating from any side of the microphone. This is verified by the graph in Fig. 1.

As can be seen in Fig. 2, the sensitivity of the microphone to high frequencies is not uniform for signals coming from below, toward the sides, and directly down on the top. This tendency of the microphone to become somewhat directional at high frequencies is due to such things as the location

of the diaphragm at the top of the microphone, the size of the microphone in respect to the wavelength of the high-frequency sounds picked up, and the shape and bulk of the microphone case.

Usually a practical working model of any piece of mechanism includes some compromises and is constructed in some certain physical form by necessity. This holds true with the Electro-Voice Model 654 and is responsible for its shape and size.



Fig. 6. Shure Model 530 Slendyne Omnidirectional Dynamic Microphone.



Fig. 7. Astatic Model M-352-S Dynamic Omnidirectional Dynamic Microphone.

The Model 654 (Fig. 5) is slim. It is  $1 \frac{3}{32}$  inches in diameter and  $10 \frac{1}{16}$  inches long and finished in nonreflecting metallic gray to



## 88% OF RADIO AND TV SERVICE MEN NOW USE UNGAR SOLDERING IRONS

*16 Interchangeable Tips and Tiplests from 23½ to 47½ watts — 700° to 1000° F. Tip Temperature*

This feather-light pencil soldering iron with its 16 interchangeable tips and tiplests will handle every soldering assignment from large metal parts such as chassis to delicate printed circuit work. An UNGAR No. 535 is a must for Printed Circuit Repair.

If you are not stocking this profitable UNGAR Soldering line you are passing up many easy sales.



Now being consistently advertised to Radio and TV Service Men. Send for Jobber Price List and order this U-135 display, stocked.

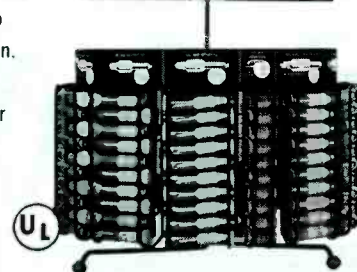

**Ungar** ELECTRIC TOOLS, INC. 4101 Redwood Avenue, Los Angeles 66, Calif.

make it inconspicuous for TV and other applications. The "pop-proof" head shield serves as a guard, dust screen, and filter which reduces breath and wind blasts. Besides containing a line-matching transformer, the cylindrical steel case encloses an air chamber which loads the diaphragm in the correct manner to increase the low-frequency response of the microphone. The case acts as a baffle for the microphone in a manner that is similar

to the way an enclosure or cabinet is a baffle for a loudspeaker.

This is a very brief account of a few of the factors that make the Model 654 a sensitive and rugged microphone that can pick up sound from all directions with barely audible frequency discriminations.

The reader, no doubt, can realize how we could start discussing the various things that have to be considered in the design of a practical high quality mi-

crophone; and as a result, we could find ourselves wandering away from the subject of directional characteristics. We have wandered this far because most of the things mentioned have effects which interact with directional characteristics.

We have used the Electro-Voice Model 654 as an example, but practically all microphone manufacturers supply several



Fig. 8. Turner Model 51D Omnidirectional Dynamic Microphone.

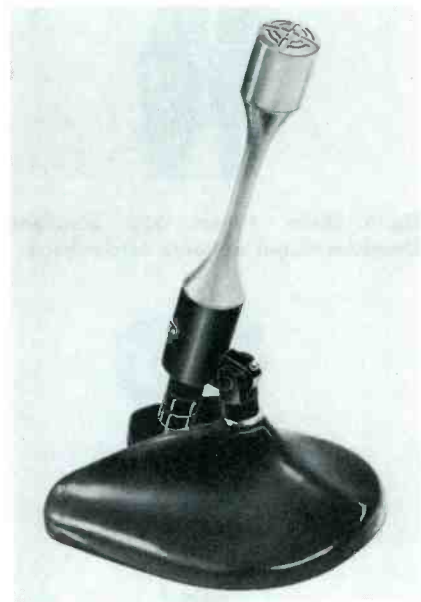

Fig. 9. American D-22 Omnidirectional Dynamic Microphone.

models of omnidirectional microphones. These vary in type, appearance, frequency response, and in many other ways including price. One of the several models made by each of four manufacturers are shown in Figs. 6, 7, 8, and 9.

Bidirectional, cardioid, and differential microphones will be discussed in the future.

by ROBERT B. DUNHAM

PF REPORTER • March, 1956

**NEW**



The Solution to Your Troublesome  
**INTERMITTENT** Problems!



**Model 5L10**  
**SECO**  
**MONITRON**

**SIGNAL TRACER  
AND INTERMITTENT  
LOCALIZER**



8222

... monitors circuits without attention

**\$119<sup>50</sup>**

**NEW for Television and Industrial Use**

In servicing TV receivers, transmitters and similar electronic equipment where the output signal does not energize a sound producing indicator, a device is needed to actuate visible and audible alarm in case of a break in the signal path. The Seco MONITRON does just that and more!

**Performs 4 basic functions:**

1. Monitors circuits without attention.
2. Monitors 2 circuits at once (on same or separate chassis.)
3. Operates as a signal tracer.
4. Makes point to point gain measurements.

Another Serviceman's Timesaver joining these indispensable Seco Testers.



**Model GCT-5**  
GRID CIRCUIT  
TUBE TESTER



**Model FB-4**  
FLYBACK CIRCUIT  
AND INDUCTANCE  
ANALYZER

Your Jobber has 'em or write for information.



**SECO MFG. CO.**

5015 Penn Avenue S.  
Minneapolis, Minn.

## Dollar & Sense Servicing

(Continued from page 34)

Videot. Badly needed is a good single word to designate those who watch TV programs. Some use televiewer, more just use viewer, but Arthur Daley of the *New York Times* prefers to call them videots in all sincerity in his sports column.

Since TV is our bread and butter, let's stick to viewers even for those who watch the grunt-and-groan boys go through their gloriously idiotic antics. Otherwise, we'd be calling too many in our own family videots.



Size. Because New York City was one of the first to have TV, it has more 10-inch sets today than any other city. Despite this, the 21-inch screen is far ahead for the country as a whole, being in just about half of all sets in use.



Beep. A Sunday commercial on WHDH in Boston gave a phone number to be called. Those trying it were told by magnetic tape that their conversation would be recorded; then they were asked to give their name and address, when they heard a beep, so that the advertised product could be sent out the next day C.O.D.

As columnist John Crosby reports the result in the *New York Herald Tribune*, playback of the tape the next day by the advertiser gave mostly the clicks of phones being hung up, a few stutters, and a few "Sorry, wrong number" replies. Investigation revealed that people in Boston became terrified when they were being recorded. One person said, "I started thinking how I sounded, and I got so nervous I forgot my address." A young man simply explained, "It's spooky talking to a beep."

In any event, before signing up for telephone answering by automation, give a thought to the reactions of your own customers. Will they also hang up and look for a service technician who keeps a human at the phone, or will they fall into step with automation?



Tomorrow. Here's a one-day prescription for exercising the soul: Do somebody a good turn without getting found out. Do one thing you don't want to do. Pause to enjoy one thing that is beautiful. Read one article that requires real concentration. Finally, spend one half hour all by yourself, meditating on your life and your future.

*John Markus*

what **you want . . .** when **you want it**

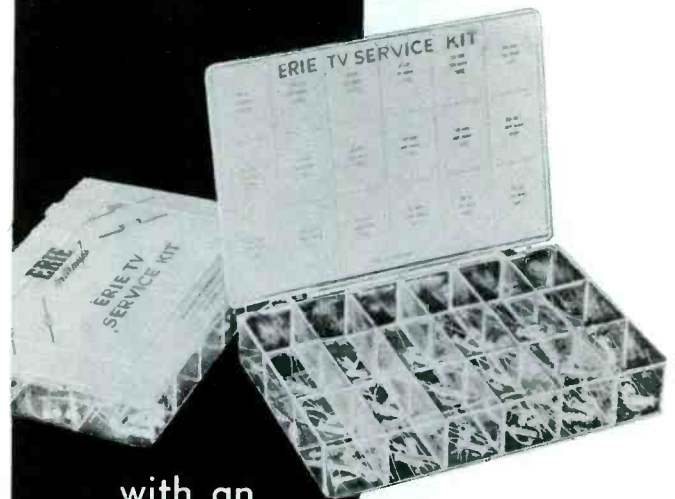

with an  
**ERIE CERAMICON®**  
**TV SERVICE KIT**

ORDER  
*Now*  
from your  
ERIE  
DISTRIBUTOR

*Here's* **WHAT YOU GET**

- 1** 63 High Stability ERIE Disc or Tubular Ceramicons
- 2** 18 Popular Values
- 3** Handy, Convenient 18 Section Plastic Storage Case
- 4** Exceptional Value

*Here's* **WHAT YOU SAVE**

REGULAR PRICE  
63 Piece ERIE Ceramicon Assortment . . . . . \$15.00  
18 Section Plastic Case . . . . . 1.75  
Total Value \$16.75

**YOU PAY . . . . . \$10.65**  
**YOU SAVE . . . . . \$ 6.10**

ERIE Disc and Ceramicon Service Kits are also available.

**ERIE** Electronics **ERIE ELECTRONICS DISTRIBUTOR DIVISION**  
ERIE RESISTOR CORPORATION  
Main Offices, ERIE, PA.  
Factories, ERIE, PA. • LONDON, ENGLAND • TRENTON, ONTARIO

"FINEST FOR REPLACEMENT,  
TOO!"



"Whether you're a wholesaler or a service dealer, Tung-Sol Tubes—the tubes that leading set-makers use—are your best bet for highest profits and customer good-will. You can build a reputation on Tung-Sol quality!"

**ts TUNG-SOL®**  
dependable  
**RECEIVING TUBES**

TUNG-SOL makes All-Glass Sealed Beam Lamps, Miniature Lamps, Signal Flashers, Picture Tubes, Radio, TV and Special Purpose Electron Tubes and Semiconductor Products.

## Product Report



**Editor's Note:**

The material appearing in this column has been taken from literature supplied by the manufacturers of the various products. The *PF REPORTER* cannot assume responsibility for claims of originality or application.

### MULTIMETER

The Superior Instrument Co., 2435 White Plains Road, New York 67, New York, has announced the new Model TV-60 Allmeter. This multimeter has a sensitivity of 20,000 ohms per volt and a mirrored scale for greater accuracy and ease of reading.



The meter is calibrated for measurements of AC and DC voltages, resistance, capacitance, direct current, and decibels. Accessory probes make the instrument adaptable for RF and audio signal tracing and for making kilovolt measurements.

### CAPACITOR TESTER

The new TeleTest CapaciTester is now available to service technicians. The instrument will test all types and sizes of capacitors for leakage while they are still in the circuit. Such testing is performed dynamically (under load) and will not damage the capacitors. A positive indication of the relative amount of leakage is obtained. A Wien bridge is included in the instrument for the measurement of capacities from 10 micromicrofarads to 50 microfarads.

Technical data about the CapaciTester is available from parts distributors or from the manufacturer, the TeleTest Instrument Corp., 30-01 Linden Place, Flushing 54, N. Y.

### NEW PLIERS

A new type of cutting pliers with the compactness of needle-nosed pliers has been announced by Xcelite Incorporated, Orchard Park, N. Y.

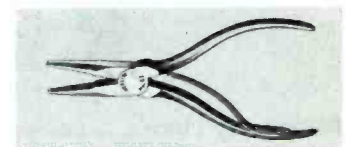

The cutting action is accomplished by jaws at a right angle to and at the ends of the long tips. A return spring permits using just the thumb and forefinger on the handles when the wire to be cut is hard to reach.



### HIGH-FIDELITY AMPLIFIER

A new 20-watt amplifier of the ultralinear Williamson type is now in production by EICO (Electronic Instrument Co., Inc.), 84 Withers St., Brooklyn 11, N. Y. The new HF20 amplifier features low distortion and high power output at both extremes of the audible frequency range. Both of these features are realized through the use of the ultralinear output stage with a conservatively rated output transformer. The built-in preamplifier provides five degrees of feedback equalization, variable-feedback tone controls, and loudness and level controls.

EICO has made the HF20 amplifier available as a kit at \$49.95 or as a factory-wired unit at \$79.95.

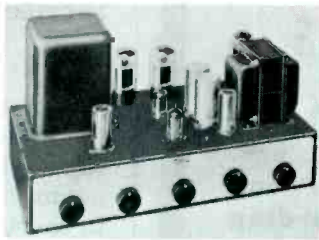

### PORTABLE LABORATORY INSTRUMENTS

A new line of portable laboratory instruments has been announced by the manufacturer, Phaostron Instrument and Electronic Company, 151 Pasadena Ave., South Pasadena, Calif.

These self-contained precision instruments are available in 38 standard ranges and have a rated accuracy of either .5 or 1.0 per cent of full-scale deflection. A built-in overload network provides meter protection for brief overloads up to 500 times the full-scale value.

Portable instruments are available with multi-range switches which provide up to 6 ranges on one meter. Each switch has a transit position for protection of the meter while it is being transported.



### RECEIVING-TUBE DISPENSER RACK

The General Electric Company has made available through their tube distributors a dispenser rack for receiver tubes. It is designed to be mounted on the wall over a service bench and to provide quick access to the tube stock.

When used properly, the dispenser rack also provides a convenient inventory aid when tubes are reordered.

The rack will hold a maximum of 250 tubes in the six different sizes of cartons. The unit is made of heavy-gauge steel and has a blue-gray, baked-enamel finish. It is shipped preassembled and includes all necessary wall-mounting hardware.



"MAKERS OF THE FINEST SETS  
USE 'EM!"



"Manufacturers of America's finest radio and TV sets are Tung-Sol customers. As a result, Tung-Sol Magic Mirror Picture Tubes and receiving tubes are made to the very highest of all set-makers' performance specifications!"

 **TUNG-SOL**<sup>®</sup>  
Magic Mirror Aluminized  
**PICTURE TUBES**

TUNG-SOL ELECTRIC INC., Newark 4, N. J. Sales Offices: Atlanta, Columbus, Culver City, Dallas, Denver, Detroit, Melrose Park (Ill.), Newark, Seattle.

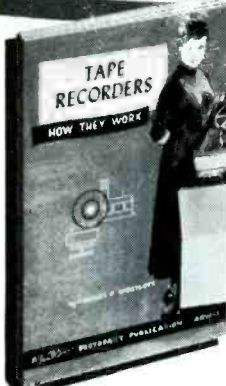

# "TAPE RECORDERS How They Work"

by Charles G. Westcott

**This is the book for everyone interested in Tape Recording**

Now you can have an expert understanding of tape recording. Explains magnetic recording theory; describes characteristics of tape. Tells how a recorder operates; discusses motorboard mechanism, drift motors, volume indicators, bias oscillators, equalization circuits, amplifiers and magnetic heads—includes diagrams, photographs and schematics. Tells you how to get best frequency response with lowest noise, how to avoid tape overload, how to obtain best bias settings; includes procedures for testing tape recorders and tape. The comprehensive book about Tape Recorders. 176 pages; 5½ x 8½"; over 150 illustrations. Postpaid, only **\$2.75**

**USE HANDY ORDER FORM BELOW**

All the Facts About  
**TAPE RECORDING**

only **\$2.75**

**ORDER TODAY**

**SAMS BOOKS**  
keep you ahead in  
**ELECTRONICS**

Sams books cover every phase of Electronics for the service technician, engineer, student or experimenter. Listed below are a few of the many valuable Sams books available at electronic parts distributors and leading book stores.

**USE THIS ORDER FORM**

**TAPE RECORDERS—HOW THEY WORK . . . . . \$2.75**

- Transistors—Their Application in Television-Radio-Electronics.** The first practical, complete book on transistors; explains circuitry, installation, testing techniques, theory and servicing. 100 pages; 5½ x 8½" illustrated. . . . . **\$1.50**
- Fundamentals of Color Television.** An up-to-date explanation of Color TV, its theory, operation, installation and servicing, with photos, block diagrams and schematics. 224 pages; 5½ x 8½"; illustrated. . . . . **\$2.00**
- Servicing TV Sweep Systems.** Describes the operation, circuit function and circuit variation of vertical and horizontal sweep systems common to most TV receivers. Tells how to analyze circuits; trouble-shoots for you. 212 pages; 5½ x 8½"; illustrated. . . . . **\$2.75**
- Technical Dictionary.** Over 4,000 definitions of radio, television, electronic, electrical and radar terms. Includes valuable charts, graphs, diagrams and symbols. Flexible binding for "on-the-job" use. 160 pages; 5½ x 8½" . . . . . **\$2.00**
- TV Test Instruments.** Tells how each instrument operates, how to use it in actual servicing. Covers Vacuum Tube VM's, AM Signal Generators, Sweep Signal Generators, Scopes, Video Signal Generators, Field Intensity Meters and Voltage Calibrators. 180 pages; 8½ x 11" . . . . . **\$3.00**
- The Recording and Reproduction of Sound.** The largest selling book in its field. Widely used by Audio engineers, Hi-Fi enthusiasts, P.A. technicians, broadcasting stations and recording studios. Authoritative chapters cover: behavior of sound waves; basic recording methods; lateral disc recording; micro-groove recording; the decibel; phono reproducers; cutting styli; microphones; loud speakers and enclosures; home music systems; public address systems; amplifiers; tuners, etc. 810 pages, 6 x 9"; illustrated . . . . . **\$7.95**

- Atomic Radiation, Detection and Measurement.** Provides a basic understanding of nuclear science and its applications. Includes a full discussion of equipment and techniques required for detecting and measuring radiation. The service technician will be particularly interested in chapters dealing with the circuitry and operation of the many types of detection devices. 200 pages; 5½ x 8½" . . . . . **\$3.00**

- Audio Amplifier Service Manuals**
- Vol. 6.** Schematic diagrams, illustrations, parts lists and invaluable servicing data on 36 amplifiers, 18 preamps and 13 tuners produced in 1953-54. All data is based on analysis of the actual equipment. 352 pages, 8½ x 11" . . . . . **\$3.95**
  - Vol. 5.** Covers 37 amplifiers, 12 preamps, 14 tuners, 1952-53. 352 pages . . . . . **\$3.95**
  - Vol. 4.** Covers 75 amplifiers and tuners produced in 1951-52. 352 pages . . . . . **\$3.95**
  - Vol. 3.** Covers 50 amplifiers and 22 tuners produced in 1950. 352 pages . . . . . **\$3.95**

- Record Changer Service Manuals**
- Vol. 6.** Includes diagrams, photos, exclusive "exploded" views, parts lists and service data for 20 popular record changers and recorders produced during 1953-54. All data based on lab analysis of the actual equipment. 288 pages, 8½ x 11" . . . . . **\$3.00**
  - Vol. 5.** 32 models; 1952-53; 288 pages **\$3.00**
  - Vol. 4.** 38 models; 1950-51; 288 pages **\$3.00**
  - Vol. 3.** 44 models; 1949-50; 288 pages **\$3.00**
  - Vol. 2.** 45 models; 1948-49; 432 pages **\$4.95**

There is an authoritative Sams book on virtually any Electronic subject in which you're interested. Check below for **FREE Book List** describing all Sams books.

**Send Book List**



Look for  
**SAMS BOOKS**  
on the  
"Book Tree"  
at your Parts  
Distributor

**HOWARD W. SAMS & CO., INC.**

Order from your Parts Jobber today, or mail to Howard W. Sams & Co., Inc., Dept. 3-C6 2201 East 46th St., Indianapolis 5, Indiana.

Send books checked above. My (check) (money order) for \$ . . . . . is enclosed.

Name . . . . .

Address . . . . .

City . . . . . Zone . . . . . State . . . . .

(outside U.S.A. priced slightly higher)

**Chemical Aids to Servicing**

(Continued from page 31)

by point. There may be flaws in the plastic coating; in addition, a slip of the hand may cause the noninsulated portion of the clip to short two leads together.

**Coil Dope**

Occasional uses will be found for a liquid polystyrene plastic in television service work. Polystyrene is advertised as a coil dope because it is especially suitable for cementing loose coils into place. This plastic is a dielectric material which has very low RF loss and which has a dielectric constant equal to that of air; therefore, it does not seriously affect the tuning of coils even at ultra-high frequencies. The application of coil dope will stop mechanical vibrations produced by coil windings which have worked loose.

A varnish which is a good coil dope is available for use on filter chokes and other coils which carry low-frequency current.

**Cleaner and Lubricant**

Dirty or corroded surfaces on sliding contacts are a major cause of noisy or intermittent operation of circuits. Carbon tetrachloride has been used for many years to clean these contacts. Recently, several companies have marketed chemical cleaners which are similar to carbon tetrachloride in their cleaning action but which leave a thin film of lubricant on the contact surface after they evaporate. The coating of lubricant resists corrosion and allows the contact surfaces to slide smoothly.

There are many methods of applying chemical cleaners to controls and contact surfaces, and the different brands of cleaners are sold in various kinds of containers which are especially suited to the different cleaning methods. The effectiveness of a technique of application depends upon the accessibility of the contact surface in each case. Plugs and other very easily reached contact surfaces can be wiped with a cloth that has been soaked with cleaner.

Contacts that are more or less in the open such as those on wafer switches can be cleaned with a brush dipped in the cleaning solution. Potentiometers and enclosed switches are harder to reach, and the cleaning of these is simplified if special applicators are used.

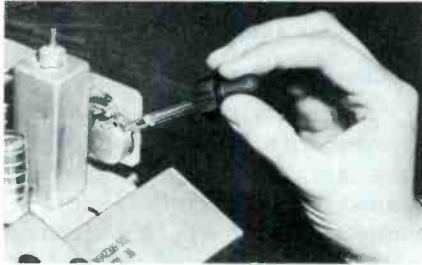

Fig. 3. Applying Cleaning Solution to a Potentiometer with a Medicine Dropper.

A medicine dropper is being employed in Fig. 3 to introduce a cleaning solution directly into the body of a potentiometer. The covers of most potentiometers contain holes through which the cleaner can be forced. The controls should be thoroughly flushed with cleaner. One company manufactures an applicator that has a long, sharp point like that of a hypodermic needle. This device can be used to inject a cleaning solution into many small places which would be hard to reach with a brush or with an ordinary dropper. Another applicator which works on the dropper principle has a long, flexible plastic

hose which may be inserted into crowded places in a chassis.

Cleaning solutions can be applied to controls from the dropper type of applicators while the controls are still mounted on a receiver chassis, but the chassis does have to be removed from the cabinet in order that the underside of the chassis will be accessible. A plunger type of applicator is available for injection of a cleaning solution into a potentiometer while the chassis is still mounted

in its cabinet. The applicator is screwed onto the threaded bushing of the potentiometer, and the liquid is forced through the space around the shaft of the control. A full discussion of the plunger applicator was given in the article, "In the Interest of Quicker Servicing," in the December 1955 issue of the *PF REPORTER*.

Contact cleaners are also available in spray applicators. These are either atomizers of the squeeze-bottle type or else pres-

(Advertisement)



MODEL 648				MODEL 715/115			
TUBE TYPE	FL.	CIRCUIT D	PLATE TEST E	FIL.	X	PLATE	YZ
*3B2	3.0	12	9	50XZ	3.0	24567	48 8Q
	12.6	126	4	15W	12.6	-	9 2S 9 5S
Latest Chart Form 648-15				Latest Chart Form 715/115-8			
MODEL 49				LATEST CHART FORM 49-3			
TUBE TYPE	SEC.	A.	B.	C.	D.	CATH. SHORTS	E.
*3B2	D	3.0	2	13568	0	-	60.
6B4B	T	6.3	4	-	78	9	7
	D	6.3	4	-	1X	2	47
	D	6.3	4	-	6X	3	47
6B88	T	6.3	4	X	12	3	30
	T	6.3	4	X	67	8	30

\* Indicates errors in December, 1955 issue.

*Consistently Dependable*

# Cornell-Dubilier

*ceramic capacitors*

Only C-D can give you the "million dollar body", made by the exclusive C-D process in the world's most modern ceramic body plant—C-D's own. This close control under one roof, from raw powder to finished product, results in greater stability and uniformity, extra durability and extended service life—even down to the tiniest disc or tubular. See your classified telephone directory for nearest C-D jobber.

**INSIST ON C-D CERAMICS — THE FINEST!**

THERE ARE MORE C-D CAPACITORS IN USE TODAY THAN ANY OTHER MAKE

# CORNELL DUBILIER

*Capacitors*

PLANTS IN SOUTH PLAINFIELD, N. J.; NEW BEDFORD, WORCESTER AND CAMBRIDGE, MASS.; PROVIDENCE AND HOPE VALLEY, R. I.; INDIANAPOLIS, IND.; FUQUAY SPRINGS AND SANFORD, N. C.; AND SUBSIDIARY THE RADIART CORPORATION, CLEVELAND, OHIO

surized cans. Sprays are efficient for rapid cleaning of multiple contacts such as those in complex wafer switches, and they are also useful in cleaning contacts that are difficult to reach by other methods. Some noise-eliminating compounds for contacts are primarily lubricants. One of these is supplied in a collapsible metal tube, and others are sold in small bottles.

No matter how a cleaning solution is applied to the contact surface of a control or switch, it should be spread evenly over the surface for best results. This can easily be done by operation of the moving parts of the control or switch until the cleaner has been well distributed.

A combined cleaner and lubricant will correct rough, noisy action in a carbon potentiometer only if the trouble is caused by dirt or dust in the control. A treatment with the cleaner will not eliminate noise that is the result of burned spots in the control, however. In the latter case, parts of the contact surface of the potentiometer have been de-

stroyed. These bad spots can be repaired only if they are filled in with a conductive substance. A repair of this type can be accomplished with a special liquid that is painted directly on the affected areas.

#### Antistatic Cleaner for Glass

Picture-tube faces and panels of safety glass are easy to clean with a liquid that is sold especially for television use. This solution contains an ingredient which prevents the build-up of electrostatic charges on the glass; consequently, dust and grime are not attracted to the cleaned glass surface.

Antistatic cleaner is sprayed or wiped on the glass, and then the glass is polished with a clean cloth. Water is not required. A bottle of cleaner lasts a long time because only a small amount of the liquid is needed for each treatment.

#### Cements

Many kinds of cements are useful in electronics service work. Some of these are intended for general use, and others are specialized cements that are most ef-

fective in joining certain materials. Cements for Bakelite, acrylic, and neoprene plastics are among those in the latter category.

Speaker cement has a thinner consistency, shorter drying time, and much less tackiness than some other radio cements. It is used chiefly as a dope for torn speaker cones and for the voice coils of speakers.

#### Chemicals for Printed Wiring

Printed-wiring boards are sprayed with silicone resin when they are new as a protection against short circuits. Before a connection on one of these boards is unsoldered, the resin should be dissolved away from the connection with lacquer thinner or alcohol. The protective coating of the wiring board can be restored after repairs have been finished because silicone resin is now obtainable in a pressurized spray can.

A solution containing colloidal silver is also used for the servicing of printed wiring. Small breaks in the wiring can be patched quickly if this liquid is brushed on.

by THOMAS A. LESH

**XCELITE Hand Tools**  
PREFERRED BY THE EXPERTS

**13 TOOLS  
READY IN LINE  
WHEN YOU HAVE  
THE 99!**



It's hard to beat this famous 13-tool kit for convenience on the bench or on the job. Those 9 precision nut drivers, the 2 slotted and 2 Phillips screwdrivers are always ready. That 1" diameter XCELITE handle fits the hand and fills the hand. No wonder you'll find 99 kits most everywhere electronic work is done.

**HANDLE FITS SUPEREAMER!**  
There's a pocket in every 99 for the Supereamer, that extra-tough king-size chrome-plated XCELITE reamer. Ask your supplier!

**XCELITE, INCORPORATED**  
Dept. Q, Orchard Park, N. Y.  
In Canada — Charles W. Pointon Ltd., 6 Alcina Ave., Toronto, Ont.

*For Originality*  
**LOOK TO XCELITE**



*the YARDSTICK  
of leadership*  
**POINTS TO**



**PHONO NEEDLES**

**PERMO PERMO, INC. CHICAGO 26**

## Time Constants

(Continued from page 27)

B; however, it should be mentioned that the current flow through the resistor during discharge time is in a direction opposite to the current flow during charge time.

The time-constant principle can be used to calculate the voltage waveforms which are developed across the components in an RC circuit. For example, let us suppose that a 60-cycle square wave having an amplitude of 10 volts is applied to the circuit shown in Fig. 3. The time duration of each pulse would be  $\frac{1}{120}$  second or approximately 8333 microseconds. The time constant of the circuit is 1400 microseconds which is slightly more than  $\frac{1}{6}$  of the duration of the square wave.

When the leading edge of the square wave appears across the circuit, the current through the resistor is maximum. This current decreases rapidly, however, because the charge which builds up across the capacitor opposes the voltage applied from the generator. By the time the trailing edge of the square wave appears, almost no current flows in the circuit because the charge across the capacitor has reached the peak value of the square wave.

When the voltage from the generator drops to zero, the capacitor starts to discharge and the voltage across this component decreases, as shown by waveform  $E_C$ . The direction of the discharge current is opposite to that of the charge current, and the polarity of the voltage across the resistor reverses, as indicated by waveform  $E_R$ . If the square wave is symmetrical, the capacitor will have sufficient time to discharge completely and the current in the circuit will decrease to zero.

A true square wave is comprised of an infinite number of sine waves, and the frequencies of these are odd multiples of the repetition rate of the square wave. At 60 cycles (the lowest odd multiple), the impedance of the capacitor in Fig. 3 is about 10.6K ohms or nearly twice that of the resistor. At 180 cycles (the third harmonic frequency), the imped-

# NO Comparison!

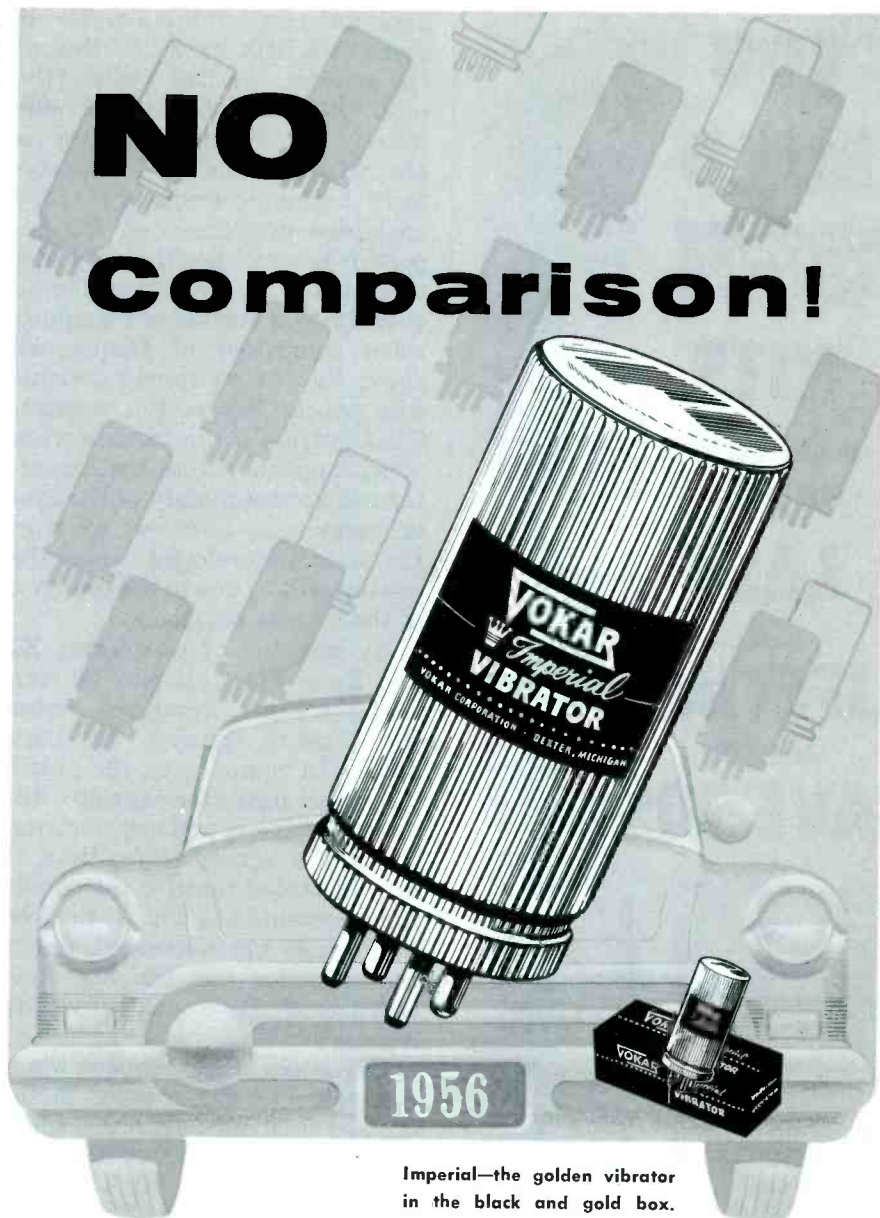

Imperial—the golden vibrator in the black and gold box.

Try any 12-volt replacement vibrator—none can compare with Vokar Imperial for value and performance!

3129 — 3 prongs, 12-v, base no. 9

Prepare now for big increase in 12-volt replacements (all '56 cars have 12-volt systems!).

Two Imperials will fill all your replacements!

- Imperials are Sahara Dry-Packed to keep points corrosion-free, provide sure starts.
- Imperials have extra-large points, Vapor-Block coated to eliminate early-life failures.
- Imperials are Whisper-Quiet to assure unequalled radio reception.

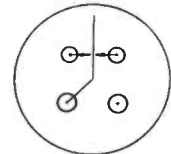
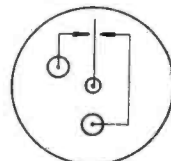

4124 — 4 prongs, 12-v, base no. 4

Order your supply of 12-volt Imperials now—unlimited shelf-life—unconditionally guaranteed!



# VOKAR

VOKAR VIBRATORS  
—preferred by  
leading manufacturers  
of auto-radios.

VOKAR CORPORATION • Dexter 3, Michigan

# YOU BUILD EICO KITS IN ONE EVENING BUT THEY... LAST A LIFETIME AND YOU SAVE 50%

150 kc-435 mc; 6 fund. bands.  
46 MODELS TO CHOOSE FROM! — THE INDUSTRY'S MOST COMPLETE LINE OF MATCHED TEST INSTRUMENTS

1/2-million EICO Instruments are now in use the world over! That's the proof of EICO's leadership in Value. For latest precision engineering, finest components, smart professional appearance, lifetime performance and rock-bottom economy—see and compare the EICO line at your Jobber before you buy any higher-priced equipment! You'll agree with over 100,000 others that only EICO Kits and Instruments give you the industry's greatest values at lowest cost.

Write NOW for FREE latest Catalog PF-3

Prices 5% higher on West Coast



New #460 Color & Black-&-White Wide Band 5" Scope Kit \$79.95 Wired \$129.50



425K 5" Scope Kit \$44.95 Wired \$79.95

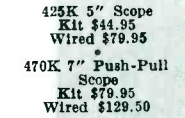

470K 7" Push-Pull Scope Kit \$79.95 Wired \$129.50



231K VTVM Kit \$25.95 Wired \$39.95

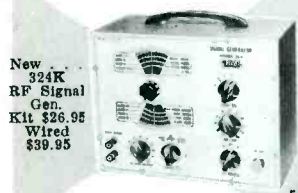

New 324K RF Signal Gen. Kit \$26.95 Wired \$39.95



565K Multimeter Kit \$24.95 Wired \$29.95 20,000 ohms/volt



377K Sine & Square Wave Audio Gen. Kit \$31.95 Wired \$49.95

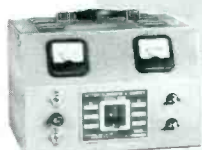

1050K Battery Elim. Kit \$29.95 Wired \$38.95



625K Tube Tester Kit \$34.95 Wired \$49.95

• Tests new 600 ma series string type tubes



©56 84 Withers Street, Brooklyn 11, N. Y.

ance of the capacitor is about 3.5K ohms or a little over half that of the resistor. At 540 cycles (the ninth harmonic frequency), the impedance of the capacitor is about 1.75K ohms. At the twenty-third harmonic frequency (1380 cps), the impedance of the capacitor becomes less than 1/10 that offered by the resistor; consequently, that portion of the square wave comprised of frequencies above the twenty-third harmonic will appear across the resistor. That portion of the square wave which appears across the capacitor will consist mainly of the lower harmonics; however, some of the voltage developed across the resistor will be due to the presence of these lower harmonics.

By analysis of waveforms  $E_R$  and  $E_C$  in Fig. 3, it may be seen that the signal developed across the resistor consists of sharp pulses. In comparison, the pulses developed across the capacitor appear much wider and approach the shape of a square wave; thus, it may be stated that for the conditions presented in Fig. 3, the low frequencies are developed across the capacitor and the high frequencies are developed across the resistor.

Let us see what happens when the value of the resistor is increased to about 33K ohms while the value of the capacitor is unchanged. (See Fig. 4.) The time constant of the circuit becomes 8250 microseconds or nearly the same as the duration of the square wave. The impedance of the capacitor at 60 cycles is still 10.6K ohms; but since the value of the resistor is more than three times this value, more voltage is developed across the resistor than across the capacitor even at the lowest frequency represented by the square wave.

Since the time constant of the circuit is practically the same as

the duration of the square wave, the capacitor can only charge to a value of 6.32 volts. Note that the time between pulses is also equal to the time constant  $T$ . Because these are equal, the voltage across the capacitor will only decrease by 63.2 per cent each time the applied voltage drops to zero. The charge across the capacitor accumulates until, after a few cycles, this charge will increase to the peak value of the square wave during charge time and will decrease by 6.32 volts during discharge time. Notice that the pulses developed across the capacitor are much broader and that more voltage at the lower harmonics is developed across the resistor.

As the value of the resistor is increased further, the time constant of the circuit becomes longer. The capacitor will have less time to charge and discharge, and more of the voltage will appear across the resistor. With a resistance value of 330K ohms, the time constant of the circuit will be nearly 100 times the duration of the square wave and practically all of the signal will appear across the resistor.

### Differentiating Network

The time-constant principle is used in differentiating circuits. The dictionary states that the term *differentiate* means "to make different or to effect a difference in." This definition is descriptive of the effect which a differentiating circuit has upon AC signals. Such circuits are commonly used in television receivers to shape the waveforms of the synchronizing signals before they are applied to the horizontal oscillator. Differentiating circuits have relatively short time constants in comparison to the duration of sync pulses; therefore, most of the voltage is developed across the capacitor

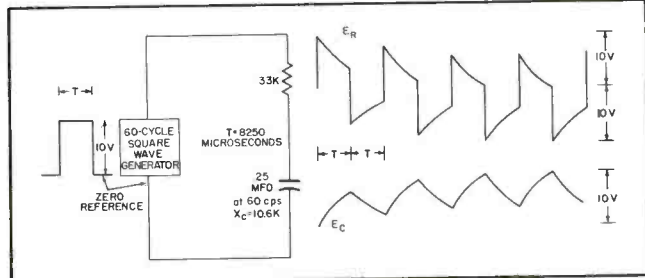
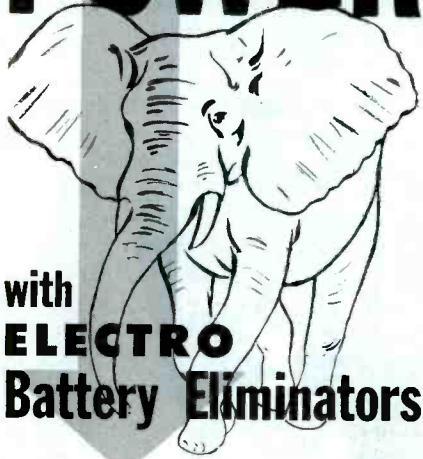

Fig. 4. An RC Circuit in Which the Duration of the Applied Voltage Is Equal to  $T$ .

# 25% more POWER



with  
**ELECTRO**  
Battery Eliminators



6/12-volt DC Power Supply . . .  
operates all 6 & 12-volt auto radios

Same price range as Kits!

Heavy duty control transformer offers better regulation and withstands overloads for long service. Electro application of larger selenium rectifiers, combined with EPL patented conduction cooling increases rectifier power rating at lowest operating cost. Rugged, high quality construction, superior filtering, wide application. **\$39<sup>95</sup>**

Only Electro offers actual proof  
with performance charts

DC Output Voltage	Amperage Output		% AC Ripple
	Continuous	Intermittent	
0-8	0-10	20	5
0-16	0-10	20	5

Model "NF" DC Power Supply  
0-28 volts up to 15 amperes

Less than 1% ripple at top load. Intermittent loads up to 25 amperes. Acclaimed in industry for its unmatched performance and construction at this price. Certified performance. **\$195<sup>00</sup>**



122-55

SEND TODAY FOR  
DETAILED BULLETINS!

See your Electro representative or write

**ELECTRO PRODUCTS LABORATORIES**  
4501-PF N. Ravenswood Ave., Chicago 40, Ill.

and very sharp voltage spikes are developed across the resistor.

A simple differentiating circuit is shown in Fig. 5. Note that the signal applied to the horizontal oscillator is that which is developed across the resistive portion of the network. The time constant of this circuit is:

$$T = (500 \times 10^{-12}) (2 \times 10^3) \\ = 1 \text{ microsecond.}$$

The horizontal sync pulse at the end of each scanning line has a time duration of 5 microseconds. This pulse is essentially a square wave although the rise time may be as much as a quarter of a microsecond. A sine wave having the same positive duration as a horizontal sync pulse would have a frequency of 100,000 cps. This, then, is the fundamental frequency of the sync pulse; but since this pulse is a square wave, it is comprised of the fundamental frequency and several odd harmonic frequencies. If the rise time of the pulse is .25 microsecond, the leading edge would represent a frequency of 2 megacycles; therefore, such a pulse would be comprised of a number of odd harmonics having frequencies between .1 and 2 megacycles per second.

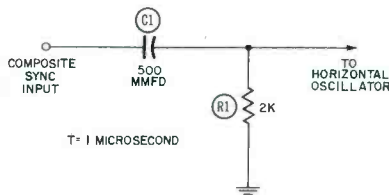

Fig. 5. A Simple Differentiating Circuit.

When a horizontal sync pulse is applied to an RC circuit like that shown in Fig. 5, the high-frequency components of the pulse will appear across the resistor and the low-frequency components will appear across the capacitor. At the first instant, the current flow in the circuit will be maximum. The voltage across the resistor at this time will equal the peak voltage of the sync pulse. Since the time constant of the circuit is relatively short, the capacitor will charge rapidly and the current flow will decrease to almost zero during the 5-microsecond duration of the horizontal sync pulse.

You can give  
your customers

BETTER MUSIC  
WITH THEIR  
PRESENT  
PHONOGRAPHS

by installing the **NEW**

**SHURE** "Twin Lever"  
Ceramic Cartridge



You can dramatically improve the tone quality of your customers' phonographs with the SHURE WC10 "Twin-Lever" cartridge. With this remarkable new Ceramic Cartridge your customers can enjoy the luxury of fine music reproduction at low cost.

The WC10 has a peak-free frequency response from 40 to 13,000 cps. It replaces most 3-speed, plastic cased cartridges, crystal or ceramic, turn-over or single needle . . . and is quickly installed on any tone arm with standard 1/2" mounting centers.

The unique "Twin-Lever" design, with each needle on its own shaft, provides improved, individually correct compliance for each record speed.

Needle replacement can be accomplished in seconds—without tools—with the cartridge in the pickup arm.

WC10 with two sapphire needles—  
LIST PRICE \$9.50

WC10D with diamond needle for LP and sapphire needle for 78RPM—  
LIST PRICE \$34.00

Available from your local SHURE distributor

**SHURE** The Mark of Quality

SHURE BROTHERS, INC., SALES DIVISION  
225 W. HURON ST. • CHICAGO 10, ILL.  
Please send me detailed information on the SHURE "Twin-Lever" Cartridge.

NAME.....  
ADDRESS.....  
CITY..... STATE.....  
PFR



more new  
\*correct  
replacement  
flybacks

(Horizontal Output Transformers)

by **TRIAD**

TRIAD  
D-72 Westinghouse  
\*Correct  
Replacement

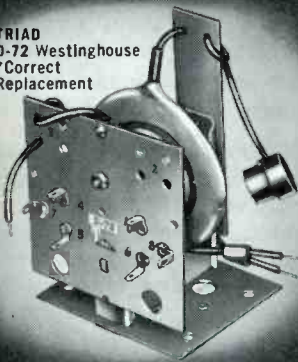

- D-64 List Price \$10.50. Correct replacement for Wells-Gardner Part 53x319, 53x320
- D-66 List Price \$10.50. Correct replacement for Sentinel Part 22E57, -2, -3, -5, -6, 22E61, -2, -3
- D-68 List Price \$13.00. Correct replacement for Motorola Part 24K721301, C, 24K722126
- D-72 List Price \$10.75. Correct replacement for Westinghouse Part V-11548-1, -2, -3
- D-73 List Price \$9.75. Correct replacement for Westinghouse Part V-9904-1, 10213-1
- D-76 List Price \$9.75. Correct replacement for General Electric Part RTO 131, 141, 163-3

TRIAD \*Correct Replacement flybacks are mechanically and electrically correct ruggedized versions of manufacturer's items — and wherever possible **COMPOSITE REPLACEMENT** to fill a number of requirements where mechanical and electrical specifications are identical.

Write for catalog TV-155C



4055 Redwood Ave. • Venice, Calif.

Refer to Fig. 6A, and note that the capacitor is essentially charged to the peak value of the horizontal sync pulse at the end of 5 microseconds. The voltage applied to the circuit drops to

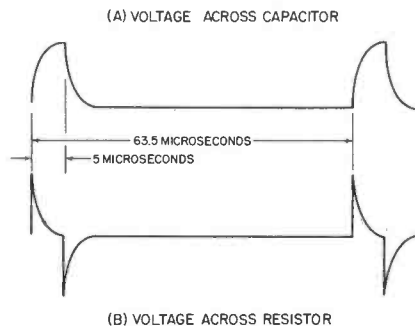

Fig. 6. Voltage Waveforms Caused by the Application of Horizontal Sync Pulses Across Components of a Differentiating Circuit.

zero, and the capacitor starts to discharge. Fig. 6B shows that the voltage across the resistor is the same as that across the capacitor; however, the polarity of this voltage is opposite to that which was present at the instant of sync pulse application. It can be seen that the voltage waveform developed across the resistor during discharge time is the same as the waveform developed during charge time except for the difference in polarity.

Note that the sharp leading and trailing edges of the horizontal pulse have been retained in the signal which appears across the resistor. The positive spike across the resistor is produced during charge time, and the negative spike is produced during discharge time. The positive spike is used to trigger the horizontal oscillator. The negative spike is not used and is usually eliminated when the signal developed across the resistor is passed through a stage which is driven to cutoff or saturation by the negative portion of the signal.

When the equalizing pulses appear at the input of the differentiating circuit, a similar action takes place. The duration of one of these pulses is about half that of a horizontal pulse although the amplitudes of the two pulses are about the same. The signal waveforms developed across the RC network by the equalizing pulses

## THE BOOK YOU NEED TO PRICE WITH SPEED... for profit

quick check for 60,000 prices

Profit-making time-money-phone call-saver. 200 pocket-sized pages. Replacement parts listed by manufacturer, product and part number. up-to-date charging information. Completely revised 4 times a year.



### and the perfect partner... DAVE RICE'S OFFICIAL TV-RADIO SERVICE ORDER BOOK

For TV, Radio, Phono or Hi-Fi service, provides separate listings for:

Picture tubes, receiving tubes, parts and components, serial numbers, labor and state and local taxes. 5 1/2" X 8 1/2" — 50 sets of triplicate orders — carbons bound in. at parts distributors or send check to

**ELECTRONIC PUBLISHING CO., INC.**  
180 NORTH WACKER DRIVE • CHICAGO 6, ILLINOIS

**DIGEST:** \$2.50 per copy.  
**ORDER BOOK:** \$7.50 each or \$6.50 per dustproof box of 10.

"Very useful to me" - Conway, Penna.  
"Been able to find every item" - Frankfort, Ky.

"Nice to have all prices" - Kincaid, Pa.

"It's a perfect book" - Tammach, Ont.



are shown in Fig. 7. Note that two equalizing pulses occur during one horizontal-scanning period. Only the alternate positive pulses

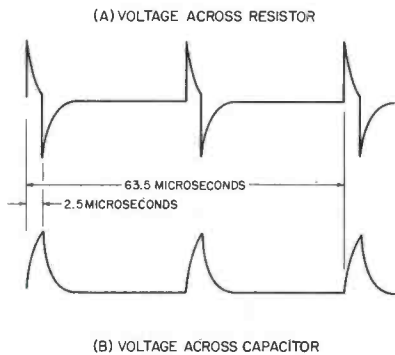

Fig. 7. Voltage Waveforms Caused by the Application of Equalizing Pulses Across Components of a Differentiating Circuit.

developed across the resistor will trigger the horizontal oscillator. The other positive pulses will arrive at the grid of this stage at a time during horizontal scanning when the oscillator circuit cannot be affected by pulses of this amplitude.

The signal waveforms in Fig. 8 are developed across the compo-

nents of the differentiating network when the serrations in the vertical sync pulse appear.

The time duration of each of these serrations is about the same as that of the equalizing pulses; however, the serrations appear as negative pulses instead of positive ones. A comparison of Figs. 7 and 8 will show that the signals developed across the components in a differentiating network by the equalizing pulses and by the serrations in the vertical sync pulse are very similar. The difference

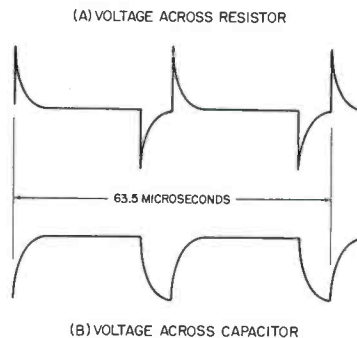

Fig. 8. Voltage Waveforms Caused by the Application of Vertical Sync Pulses Across Components of a Differentiating Circuit.

between the signals is that they are opposite in polarity.

It is interesting to note that the positive spikes in Fig. 7A are developed by the leading edges of the equalizing pulses; whereas, the positive pulses in Fig. 8A are developed by the trailing edges of the vertical serrations. As in the case of the equalizing pulses, two positive spikes are developed during one horizontal-scanning period, and only the alternate positive spikes will trip the oscillator.

### Integrating Network

The time-constant principle is also used in an integrating network. There are two major differences between an integrating network and a differentiating network. An integrating network has a longer time constant, and the output signal of this circuit appears across the capacitor instead of across the resistor. A simple integrating network is shown in Fig. 9.

Integrating networks are commonly used ahead of vertical oscillator circuits in television receivers. The time constants of

# the **1** **ST** COMPLETE LINE OF ELECTRONIC TOOLS... ever offered the industry

**HUNTER** Tools, originators of the TV Slug Retriever, now offer the only *complete* line of Electronic Tools available. Each is designed to do a specific job — and **HUNTER** manufactures these tools with the exacting requirements of the serviceman in mind. Complete satisfaction guaranteed. **HUNTERS** years of experience in the hand tool field assures you of the finest Electronic Tools.

## Famous HUNTER Tools...



- ★ SLUG RETRIEVERS
- ★ SCREWHOLDING SCREW-DRIVERS
- ★ NUT DRIVERS
- ★ DURA TIP SCREW-DRIVERS
- ★ SPIN DRIVERS
- ★ INSULATED DRIVERS
- ★ BELT TOOL KITS
- ★ HEX DRIVERS
- ★ DRIVE ALL JUNIOR
- ★ SMITTY (Allen Type) DRIVERS
- ★ TENSION TWEETIE
- ★ HOT TUBE PULLERS
- ★ ALIGNMENT TOOLS
- ★ SEPARATELY OR COMPLETE KITS

ALL TOOLS IN SIZES TO FIT YOUR SPECIFIC NEEDS!

Write for a free copy of our new complete catalog, today!

# HUNTER TOOLS

BOX 564 • WHITTIER, CALIFORNIA

TOOLS DESIGNED FOR THE ELECTRONICS INDUSTRY

### JOBBERS:

Order your matched displays, today!



Service Master #100

### DISPLAYS THAT COMPLIMENT YOUR STORE



Service Master #500

such circuits in commercial use are between 100 and 500 microseconds. As shown in Fig. 10, each horizontal sync pulse has such a short duration in comparison to the time constant of the integrating network that only low voltages are developed across the capacitor by these pulses.

When a vertical sync pulse arrives at this circuit, a voltage waveform like that shown in Fig. 11 is developed across the capacitor.

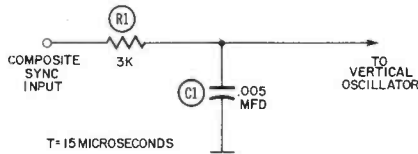

Fig. 9. A Simple Integrating Circuit.

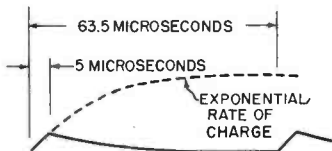
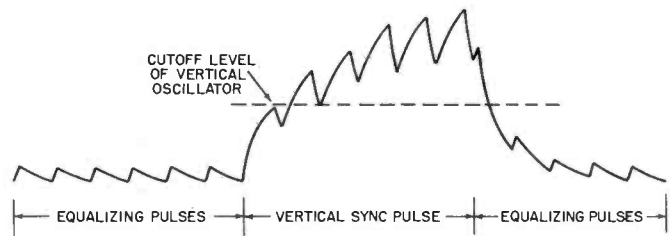

Fig. 10. Voltage Waveform Developed Across the Capacitor in an Integrating Circuit and Caused by Application of a Horizontal Sync Pulse.

Fig. 11. Voltage Waveform Developed Across the Capacitor in an Integrating Circuit During the Vertical-Retrace Period.



itor. Note that the duration of each equalizing pulse is so short that the capacitor cannot be charged an appreciable amount before it is discharged. The duration of time between the equalizing pulses is nearly 30 microseconds; therefore, the capacitor has sufficient time to be discharged almost completely before the next pulse charges it again.

The time duration between serration pulses is slightly more than 25 microseconds, and the duration of each serration is just under 5 microseconds. The capacitor is charged for a little more than 25 microseconds, but it is discharged for about 5 microseconds. As a result, the voltage across the capacitor increases between serration pulses. After two or three

serration pulses have occurred, the voltage across the capacitor will be sufficient to trigger the vertical oscillator.

An integrating network which is used commercially is shown in Fig. 12. Actually, this network is a combination of three RC circuits. The time constant of the

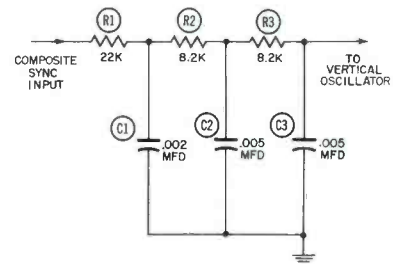
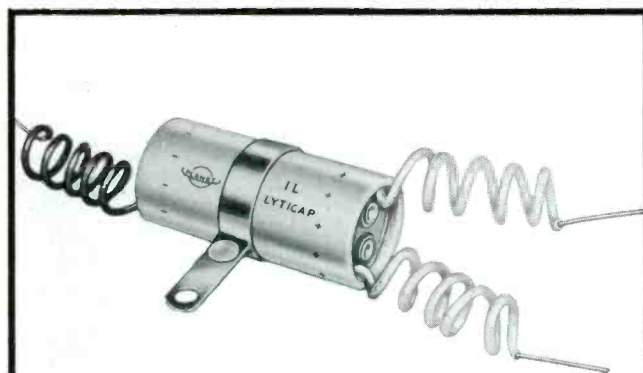

Fig. 12. Schematic Diagram of a Commercial Type of Vertical-Integrator Network.



**NEW DUAL SECTION ELECTROLYTIC CAPACITORS HERMETICALLY SEALED IN ALUMINUM TUBES WITH COMPLETELY FLEXIBLE INSULATED LEADS.** By riveting the leads directly to the condenser end disc, Planet has eliminated the use of rigid terminal risers ordinarily used on this type construction. This allows Planet Type 1L capacitors to fit into a smaller space and eliminates the possibility of lead breakage.



**"ENGINEERED FOR QUALITY"**  
GUARANTEED FOR ONE YEAR

**PLANET MANUFACTURING CORPORATION**  
225 BELLEVILLE AVENUE  
BLOOMFIELD, N. J.

Write for Catalog 200—Lists Specifications on Stock Items

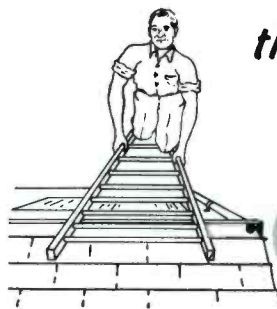

*the "2nd" trip up..*  
**costs YOU!**

**STOP**  
Antenna Call-Backs  
due to broken leads

*with*

the  
**mosley**  
**'Y-TY'**



Antenna Terminal Connector  
No. 263, List Price \$ .80

TV installation profits vanish when you're called back to repair a wind-whipped lead-in connection!

Protect those profits — and your reputation — by using the Mosley "Y-TY" on each antenna you install.

A sturdy clamping member locks around the complete line . . . takes the strain off the fragile copper strands! The plated brass connecting straps bend and twist to fit any antenna type.

Another Premium Quality MOSLEY Product . . .  
to help YOU make More Installation Profits!

At Radio and Television Parts  
Distributors, Coast-to-Coast.

**MOSLEY ELECTRONICS, Inc.**  
8622 St. Charles Rock Rd., St. Louis 14, Missouri

total circuit can be computed in the following manner. Let  $T$  equal the time constant of the total circuit; then

$$T = R_1(C_1 + C_2 + C_3) + R_2(C_2 + C_3) + R_3(C_3).$$

Substituting values for the resistors and capacitors, we find that

$$T = 22 \times 10^3(.012 \times 10^{-6}) + 8.2 \times 10^3(.01 \times 10^{-6}) + 8.2 \times 10^3(.005 \times 10^{-6})$$

$$T = (264 \times 10^{-6}) + (82 \times 10^{-6}) + (41 \times 10^{-6})$$

$$T = 387 \times 10^{-6} \text{ seconds, or } 387 \text{ microseconds.}$$

The use of three RC sections instead of one provides two distinct advantages. (1) Noise pulses are not likely to trigger the oscillator because they would not have a time duration and a repetition rate similar to the vertical sync pulses. (2) A filtering action is provided so that the sawtooth contour of the voltage applied to the oscillator circuit will not be so pronounced as that shown in Fig. 11.

It is interesting to note that all three of the RC sections of the network shown in Fig. 12 do not have equal time constants. The network is intentionally designed this way to immunize the oscillator further against triggering caused by the presence of random noise pulses.

by VERNE M. RAY

**NEW** HOMOGENIZED

**"QT"** 95¢

(Giant 3 oz. btl. with applicator)

for **QUIET CONTROLS**  
**QUIET CONTACTS**

**CLEANS and PRE-SERVES . . . eliminates noise . . . retards corrosion. NONE BETTER!**

successor to Grayburne

**SupereX** ELECTRONICS CO. 4 Radford Pl., Yonkers, N.Y.

from the VOICE OF AUTHORITY IN SWEEPS . . .

# SPOT and FIX TV FAULTS FAST!

**FREE** RAM BOOK SHOWS HOW!

Typical latest field-proven servicing data you'll find in your RAM book:

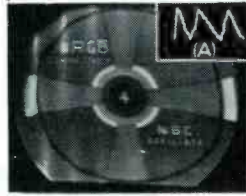

**FAULT:** "Ringing."  
**CAUSE:** Incorrect value of balancing R-C network across one-half of H. Yoke winding.  
**(A):** H. Yoke current wave-form. Obtained by connecting scope across 10-ohm resistor inserted in series.

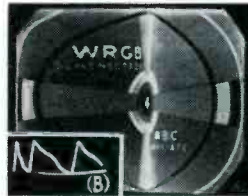

**FAULT:** Picture compression and stretching.  
**CAUSE:** Capacitance value of boost capacitor (connected to linearity coil) too low.  
**(B):** H. Yoke current wave-form. Leaky boost capacitor could cause similar effect.

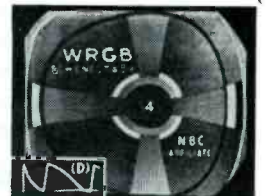

**FAULT:** Picture stretching at left and compression at right.  
**CAUSE:** 0.02 mf boost capacitor (connected to linearity coil) used instead of 0.1 mf capacitor.  
**(D):** H. Yoke current wave-form.

For over 10 years, RAM has specialized and pioneered in sweeps exclusively. RAM designs them, makes them, counsels TV set manufacturers on them, field-services them, educates Servicemen on them — leads the industry.

No one but RAM can bring you such proven data — as shown here and in the RAM Manual. In manufacturing know-how and field experience, you can depend on RAM for . . .

**THE VOICE OF AUTHORITY IN SWEEPS**

Send coupon today — get the BEST information from the FOREMOST manufacturer now!



**RAM ELECTRONICS SALES CO.** · Irvington, N. Y.

Canadian Sales Division: Telequipment Mfg. Co., Ltd., Ontario

Export Dept: Dage Corp., 219 E. 44 St., New York, N. Y.

## Get more out of your job—or hobby with Gernsback Library Books

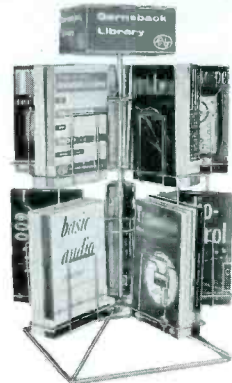

Look for this new revolving counter rack at your distributors.

**TRANSISTORS**  
Transistors — Theory and Practice—No. 51. For the practical man—theory and applications in circuits. 144 Pages. \$2.00

**RADIO-CONTROL**  
Radio-Control Handbook—No. 53. A complete, practical guide on how to build R/C systems. 192 Pages. \$2.25

**Model Control by Radio**  
—No. 43. Theory of R/C and practical suggestions on building units. 112 Pages. \$1.00

**RADIO & TV HINTS**  
—No. 47. 300 hints, kinks and short cuts. 112 Pages. \$1.00

Now—a complete library of low-cost books to help you get ahead in your job or get more from your hobby. These complete, easy-to-read books will give you new ideas, show you short cuts,

and save costly mistakes which may be worth hundreds of dollars to you. Pick out the books you need—if your distributor doesn't have them, send in the coupon below today.

**NEW!** The V.T.V.M.—No. 57. How to use the V.T.V.M. to best advantage. 224 Pages. Paper cover \$2.50. Hard cover edition \$4.60

**Sweep and Marker Generators**—No. 55. 224 Pages. Paper Cover \$2.50. Hard cover \$4.00

**Probes**—No. 54. 224 Pages. Paper cover

**NEW!** Basic Audio Course — No. 66. Audio fundamentals from theory of sound to advanced techniques. 224 Pages. Paper cover \$2.75. Hard cover \$5.00

**FUNDAMENTALS**  
Basic Radio Course—No. 44. Easy-reading but thorough book on fundamentals from Ohm's Law to circuit analysis. Hard cover. 176 Pages. \$2.25

**Radio Tube Fundamentals**—No. 45. How and why tubes work as they do. 96 Pages. \$1.00

**MISCELLANEOUS**  
Practical Disc Recording—No. 39. How to make disc recordings. 96 Pages. 75¢

\$2.50. Hard cover \$4.00

**The Oscilloscope** — No. 52. How to get more out of your scope. New uses. 192 Pages. Paper cover \$2.25. Hard cover \$4.00

**TV Repair Techniques** — No. 50. Hints by the experts can save you hours of servicing time. 128 Pages. \$1.50

**AUDIO-HIGH FIDELITY**  
High-Fidelity — Design, Construction, Measurements—No. 48. How to achieve top performance. Amplifier construction. 128 Pages. \$1.50

**Radio & TV Test Instruments** — No. 49. Details on how to build 22 test instruments for modern servicing. 128 Pages. \$1.50

**Television Technotes** —No. 46. Causes, symptoms and cures of over 600 actual troubles. Cuts troubleshooting time to the bone. 128 Pages. \$1.50

**High-Fidelity Techniques**—No. 42. A humorous but practical guide to getting more out of your hi-fi system. 112 Pages. \$1.00

See your distributor — or mail this coupon

**GERNSBACK LIBRARY, INC. PR-36**  
25 West Broadway  
New York 7, N.Y.

Enclosed is my remittance of \$ . . . Please send me the following books postpaid. Prices 10% higher in Canada

39  42  43  44  45  46  
 47  48  49  50  51  52  
 53  54  55  57  66

Hard cover editions by mail only.

52M  54M  55M  57M  66M

Name . . . . . (Please print clearly)

Street . . . . .

City . . . . . State . . . . .

## Troubles in AGC Circuits

(Continued from page 11)

respect to the cathode. The control grid is DC connected to the video amplifier stage through an isolating resistor. The grid voltage is such that the stage is biased to the point that only the positive-going sync pulses on the grid will cause the tube to conduct.

### 2. Raster, No Sound, No Picture.

A photograph of a TV screen when there is a raster but no sound nor picture because of faulty AGC action is shown in Fig. 9. This symptom is usually encountered in receivers that employ a keyed or amplified AGC system and is in most cases due to complete loss of the AGC voltage.

Possible causes of a raster with no sound and no picture are:

- a. Failure of the AGC keyer tube.
- b. Failure of the AGC amplifier tube.
- c. AGC control improperly adjusted.
- d. Failure of the capacitor which couples the pulse signal to the AGC keyer plate. (See C105 in Fig. 4.)
- e. Shorted AGC filter capacitor. (See C102 in Fig. 4.)

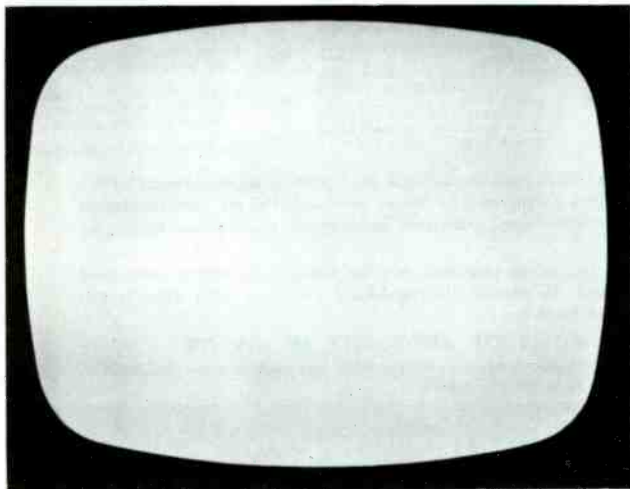

Fig. 9. Raster, No Picture.

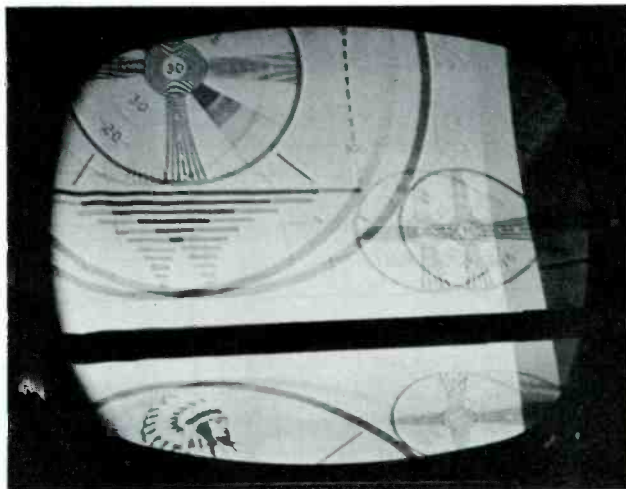

Fig. 10. Loss of Synchronization.

## TELCO TELEVISION HARDWARE

### AT YOUR DISTRIBUTOR

WRITE for your TELCO Catalog or ask your supplier. FREE!

 <b>TELCO CHIMNEY QUICK MOUNT</b> One-piece style for fast installing. <b>No. 8005</b>	 <b>TELCO DELUXE CHIMNEY MOUNT</b> All aluminum, with stainless strap. <b>No. 8001</b>	 <b>TELCO TV STAND-OFF</b> Wood-screw type, 3 1/2" long. <b>No. 8027</b>	 <b>TELCO DUPLEX STAND-OFF</b> Inline wood-screw type, 7 1/2". <b>No. 8225</b>
 <b>TELCO UNIVERSAL LIGHTNING ARRESTOR</b> UL-approved; for all lead-ins. <b>No. 8642</b>	 <b>TELCO TELEVISION ROLL-AROUND</b> Fits under most sets for easy moving. <b>No. 8957</b>	 <b>TELCO UHF-VHF LIGHTNING ARRESTOR</b> UL-approved; 300- & 450-Ohm lines. <b>No. 8640</b>	 <b>TELCO RATCHET TYPE CHIMNEY MOUNT</b> For masts to 1 1/4" dia.; fast, sure. <b>No. 9218</b>
 <b>TELCO NO-GUY ROOF MOUNT</b> Cast iron base; 1 1/2" dia. masts. <b>No. 9060</b>	 <b>TELCO HEAVY DUTY RIDGE MOUNT</b> For flat or any-angle roof; 1 1/2" mast. <b>No. 8630</b>	 <b>TELCO TUBE CHECKER</b> Series filament and continuity tests. <b>No. 9270</b>	 <b>TELCO TV LEAD-IN TUBE</b> Universal style, up to 14" wall. <b>No. 8958</b>

TELEVISION HARDWARE MFG. CO.

Division of General Cement Mfg. Co. 903 Taylor Avenue • Rockford, Illinois

THE BIG BOYS KNOW—  
YOUR BUSINESS REALLY BEGINS  
TO PAY OFF WHEN YOU START  
SELLING WALCO NEEDLES!

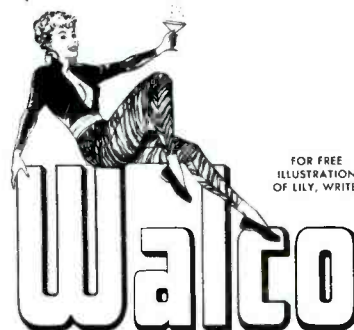

FOR FREE ILLUSTRATION OF LILY, WRITE:

TRADE NAME OF PF-3  
**ELECTROVOX CO., INC.**  
 60 Franklin St., East Orange, N. J.

f. Failure of AGC rectifier in receivers that employ the rectified type of AGC and a cascade tuner.

### 3. Loss of Synchronization.

A picture screen that shows loss of synchronization is illustrated in Fig. 10. When this symptom is caused by AGC trouble, it is usually the result of low AGC voltage which is applied to the RF or IF stages and which causes one of the IF stages to reach plate-current saturation during sync-pulse time. This causes distortion of the sync pulses and can also cause loss of synchronization depending upon the degree to which the sync pulse is distorted.

Possible causes of loss of synchronization are:

- a. Improper adjustment of the AGC switch or potentiometer.
- b. Weak AGC keyer tube.
- c. Weak AGC rectifier tube.
- d. Weak AGC amplifier tube.
- e. Low value of delay resistor. (See R47 in Fig. 2, R74 in Fig. 3, and R80 in Fig. 4.)

Loss of synchronization due to faulty AGC action is a trouble that is usually found only in strong-signal areas. In such areas, a considerable amount of AGC voltage must be applied to the RF and IF stages in order to prevent sync-pulse distortion. There are cases, however, in which the loss of synchronization will be due to insufficient AGC voltage that is not actually caused by AGC trouble.

Such a case would be a receiver in which there is leakage across the windings of an IF transformer. This type of leakage would cause a flow of electrons from the B+ circuit, and a voltage that would counteract the AGC voltage would develop. This action would occur even if the leakage were about 20 megohms. This type of trouble can be detected by measurement of the voltage drop across the resistors in the AGC distribution lines. Consult the drawing shown in Fig. 11. The voltages at points A, B, C, D, and E should all be identical. If the voltage at point B were lower

**IT'S HERE AT LAST!!!**

# the RMS "BIG SHOT" ALL-CHANNEL YAGI ANTENNA

**This is it!** The most talked about antenna in the television industry today. . . . Precision engineered to out-perform all others, the fabulous BIG SHOT miraculously produces the gain of 3 separate broad band yagis . . . eliminates complicated phasing networks that normally result in broken leads and costly errors in installation.

**Years ahead in design . . .** the low silhouette of the BIG SHOT reduces wind drag and lengthens the life of the installation. Ghosts and co-channel interferences are eliminated like magic . . . and sharper, clearer TV pictures assured. Completely automatic, each and every element can be easily locked securely in place.

Model BIG-100  
\$15.97 List

MODEL BIG-200  
(stacked) \$32.72 List

**GUARANTEED**  
for Quality and Performance

**Radio Merchandise Sales, Inc.**  
NEW YORK 62, NEW YORK

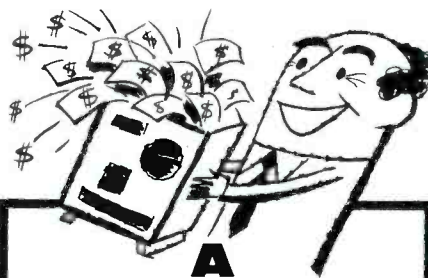
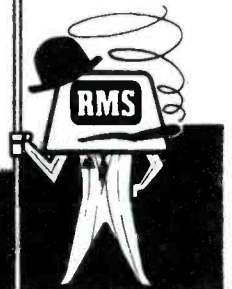

## "DO-IT-YOURSELF KIT"... FOR MAKING MONEY!

Make money with the UNIVERSITY "KwiKit", the speaker enclosure you assemble for your customers and profit 2 ways. Besides assembling the finest kit on the market, every kit leads to the sale of a speaker and components. Best of All—"KwiKit's" unique design enables you to take advantage of the wonderful selling features of P.S.E.—University's Progressive Speaker Expansion Plan for custom building.

Interested? For further information write to Desk C-5.

**University LOUDSPEAKERS, INC.**

80 So. Kensico Ave., White Plains, N.Y.

*Miss Quietrole Says...*



**"You can forget 'em all when you have..."**



## QUIETROLE

TRADE MARK REG. U.S. PAT. OFF.

the quality product that does all the lubricating and cleaning jobs on TV and radio . . . nothing does the job as well as Quietrole . . . and you can depend on that."

*"A First in the Industry"*  
"Choice of Better Service Dealers Everywhere"



**QUIETROLE COMPANY inc.**  
Spartanburg, South Carolina

In Canada

**ACTIVE RADIO & T.V. DISTRIBUTORS**  
58 Spadina Avenue • Toronto 2B Ontario

or less negative than the voltage at point A, then the second IF tube is drawing grid current or

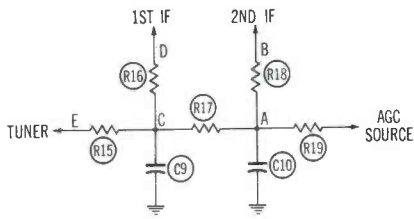

Fig. 11. AGC Distribution Line.

there is leakage across the IF transformer or coupling capacitor. A lower voltage at point C than at point A would indicate trouble in the RF or first IF stage.

#### 4. Dark Picture and Buzz in Audio.

A photograph of the TV screen when there is excessive contrast caused by improper AGC action is shown in Fig. 12. This symptom is usually the result of too much

signal output from the video detector and is often accompanied by a buzz in the audio output. Excessive signal at this point results in too much drive to the video amplifier and causes the picture to be very dark. The excessive signal from the video detector also causes the sound IF limiter or detector to be overdriven; therefore, a buzz develops in the sound. This effect is most noticeable in a receiver that has a sound IF and

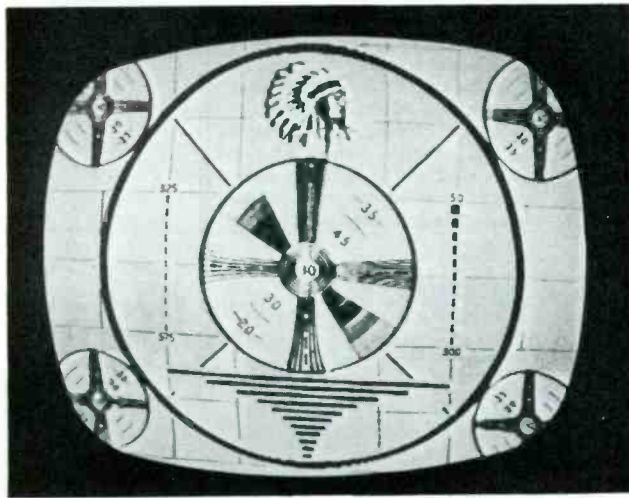

Fig. 12. Excessive Contrast.

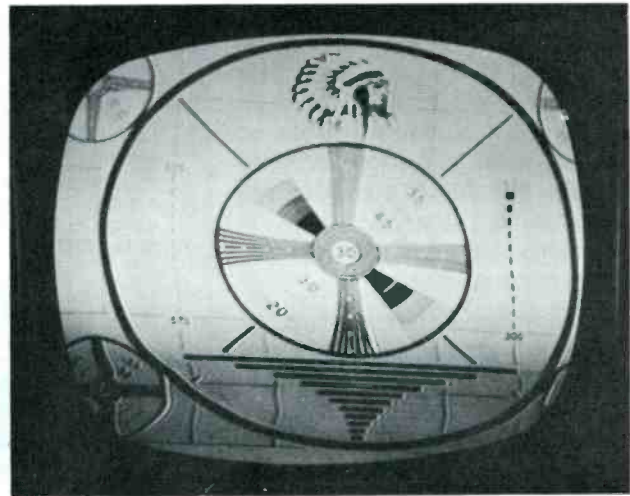



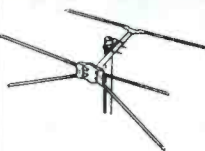
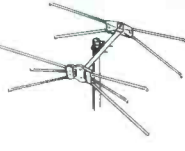
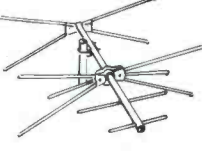





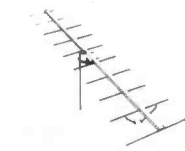
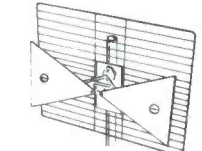

Fig. 13. Pulling Picture with Brightness Modulation.



# TELCO VHF-UHF ANTENNAS

Cover the Mass Market—109 Styles Available  
For Every TV Installation

WRITE for your TELCO Catalog or ask your supplier. FREE!

 <b>TELCO RANGER CONICAL A-100</b>	 <b>TELCO X-BACK CONICAL A-160</b>	 <b>TELCO FLYING GOOSE A-230</b>	 <b>TELCO FLYING V A-260</b>
 <b>TELCO GOLDEN HALO A-9000</b>	 <b>TELCO ROTO-INDOOR A-8160-TP</b>	 <b>TELCO GOLDEN V A-8125</b>	 <b>TELCO GLOBE-TENNA A-9265</b>
 <b>TELCO SKY-WING A-300</b>	 <b>TELCO GOLDEN YAGI A-320</b>	 <b>TELCO DELUXE BOW-TIE A-8965</b>	 <b>TELCO CORNER REFLECTOR A-8984</b>

**TELCO ELECTRONICS MFG. CO.** Division of General Cement Mfg. Co.  
903 Taylor Avenue • Rockford, Illinois

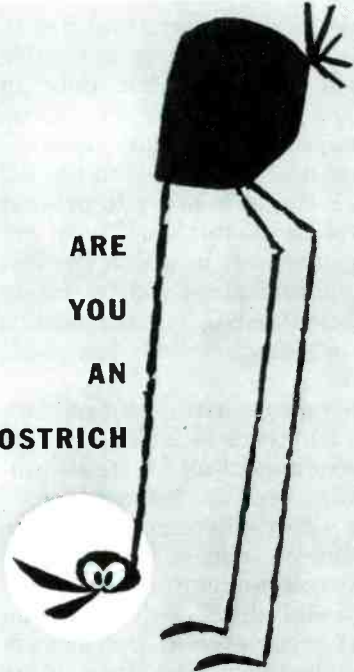

**ARE  
YOU  
AN  
OSTRICH**

... when it comes to cancer?  
Do you bury your head in the sand and hope it won't attack you or someone close to you? Fight cancer with a check-up to protect yourself and a check to help others. Give to your Unit of the American Cancer Society, or mail your gift to **CANCER**, c/o your town's Postmaster.

**AMERICAN CANCER SOCIETY**

amplifier system that is just barely adequate.

Possible causes of a dark picture with buzz in the audio are:

- a. Defective AGC keyer tube.
- b. Defective AGC amplifier tube.
- c. Defective AGC rectifier tube.
- d. Leaky AGC filter capacitor. (See C48 in Fig. 1, C24 and C27 in Fig. 2, C73 in Fig. 3, C102 in Fig. 4.)
- e. Increased value of R67 or R70 in Fig. 3.

A comparison of the AGC voltages to the tuner and IF can help to isolate the trouble because an insufficient AGC voltage to either the RF or IF stages could cause the signal to be excessive at the output of the video detector. This type of trouble will usually occur only in strong signal areas.

#### 5. Pulling Picture with Brightness Modulation.

A pulling picture with brightness modulation is shown in Fig. 13. This symptom is caused by modulation of the signal within the IF stages by an undesirable hum voltage.

Possible causes of a pulling picture with brightness modulation are:

- a. Defective AGC amplifier tube in amplified AGC systems.
- b. Defective AGC filter capacitor in the AGC line to IF stages.
- c. Defective filter capacitor in the AGC line to the RF stage.

When the AGC filter capacitor is defective (open or partially open), the AGC voltage will vary at the vertical sync rate. This variation of the AGC voltage modulates the RF or IF signal and results in a distorted signal. A check of the AGC line with an oscilloscope will reveal the presence of the undesirable signal. In some receivers, the failure of the AGC filter capacitor can result in the appearance of several black bars across the picture. This is caused by the charge and discharge of other capacitors in the circuit through the AGC filter

resistor. Without the capacity of the AGC filter capacitor, the time constant of the AGC filter network is very short and allows the voltage to fluctuate at a rate determined by the resistance of the AGC filter resistor and by the remaining capacitance in the AGC network.

#### Summary

Generally speaking, AGC troubles are caused by one of three things: (1) loss of AGC voltage, (2) insufficient AGC voltage, or (3) lack of filtering on the AGC line. Since there are more than three symptoms of AGC trouble, it follows that some of the symptoms are due to a difference in the degree of failure. In other words, low AGC voltage can cause a loss of synchronization, an overloading signal, and other troubles. The value to which the AGC voltage drops, the type of receiver, the signal level, and other factors will determine just what trouble actually appears in the receiver on which you are working at a given time. This trouble-shooting guide is presented with the idea that a study of these symptoms and their causes will help to acquaint the technician with some of the problems that will be encountered and will therefore help him to establish a basic trouble-shooting procedure so that he can effectively deal with any AGC problem.

by CALVIN C. YOUNG, JR.  
and LESLIE D. DEANE

#### Dollar and Sense Servicing

Slogans. Out in Hollywood this past season, movie folks chuckled about a widely circulated Christmas card bearing the greeting, "Help Stamp Out TV!"

Another slogan reported by *Television Digest* was originated as a gag in the offices of a large receiving-tube manufacturer. This poster showed a large booted foot about to tramp on a tiny three-pronged object and a slogan reading, "This Is Your Fight—Help Stamp Out Transistors!"

It's all good clean fun because practically all tube makers are now making transistors as well and because the movie industry has at last started opening wide its vaults to sell old and recent feature movies and short subjects to the TV industry.

MARKUS

MERIT, first in exact and universal replacement transformers, yokes, coils—the only manufacturer of transformers, yokes and coils who has complete production facilities for all parts sold under their brand name.



HVO-41 FOR EXACT REPLACEMENT IN AIRLINE, CORONADO, TRUETONE, ARLINGTON, FIRESTONE, WELLS-GARDNER, SILVERTONE, WARWICK. Another in the complete MERIT line of exact and universal replacements—the only single source for all your transformer and coil requirements.

# Merit

MERIT COIL & TRANSFORMER COMPANY  
4427 NORTH CLARK STREET  
CHICAGO 40, ILLINOIS



# International

presents

## "AIRKORE"

a new selenium replacement  
rectifier so outstanding it

# Outperforms them all!

- 12° to 15° lower core temperature.
- Overload capacity 7 times normal rating.
- 20% less aging.
- Maximum air flow in any vertical mounting position (regardless of degree of rotation).
- Increased efficiency throughout life.

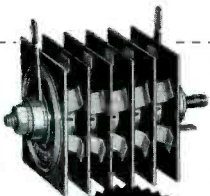

SO GOOD IT'S  
guaranteed  
for 1 year!

*AirKore provides these outstanding advantages without sacrificing the basic design of proven superiority — "center-support" construction!*

Compare any other rectifier with the new AirKore. Guaranteed for a full year, this new design assures increased efficiency...will help cut costly "call-backs." For products of the highest quality, manufactured under the most rigid standards in the industry, look for the name International.

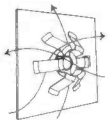

This exclusive device provides greater contact area — uniform temperature rise across the plates — increased efficiency.

AirKore design permits maximum circulation of air around the core and spring itself.



A WORLD OF DIFFERENCE  
...THROUGH RESEARCH

## International Rectifier

C O R P O R A T I O N

El Segundo, California • Phone ORegon 8-6281

In Canada: Atlas Radio Corp., Ltd.,

50 Wingold Ave. W., Toronto, Ontario • RU 1-6174

THE WORLD'S LARGEST SUPPLIER OF  
INDUSTRIAL METALLIC RECTIFIERS

## Examining Design Features

(Continued from page 24)

records turn at a speed of 16 $\frac{2}{3}$  rpm and are not to be played on existing home instruments. Some of the modern home phonographs now include the 16 $\frac{2}{3}$ -rpm speed, but the heavy pickup arms and the larger styli used are not designed for playing these records with the extra-fine grooves.

When you wish to operate the Highway Hi-Fi, the car radio must be turned on and the radio-phono switch on the player must be in the phono position. The record player is mounted on a base which slides in and out of the metal case. When the front panel is opened, the player assembly can be pulled out far enough for a record to be placed on the turntable. With the record in place, the operator presses down on the finger tab (shown in Fig. 4) protruding from the left side of the tone arm. This will free the tone arm from its resting position, and the arm must then be moved to the right until it hits the provided stop. As the arm is moved from left to right, the clutch lever pointed out in Fig. 4 is activated. This engages the drive mechanism, and the turntable automatically starts to revolve. At this point, the tab may be released and the tip of the sty-

lus will set down on the proper starting grooves of the record. It is recommended that the driver change records only during roadside stops; however, once he is familiar with the ease of operation of the unit, he may find it possible to change records without taking his eyes off the road.

The features of this instrument have overcome many of the problems which had retarded the manufacture of mobile record players in the past. One problem to consider in designing a unit of this nature is the effect of severe shock and vibration that the unit will undergo as a result of sudden stops, starts, curves, and rough roads when it is operated in an automobile. There is also the problem of frequent manual record changing which would be impractical from a safety standpoint. Another design problem stems from the necessity for having a constant-speed phono motor which would operate from a conventional automobile battery. Record storage and numerous other factors must all be taken into consideration when such a unit is to be operated in the limited space available in a moving vehicle.

In order to counteract shock and vibration, a number of special features are incorporated in the elastic suspension system of this unit. The heavy cast-metal motor board rests freely on three sponge-

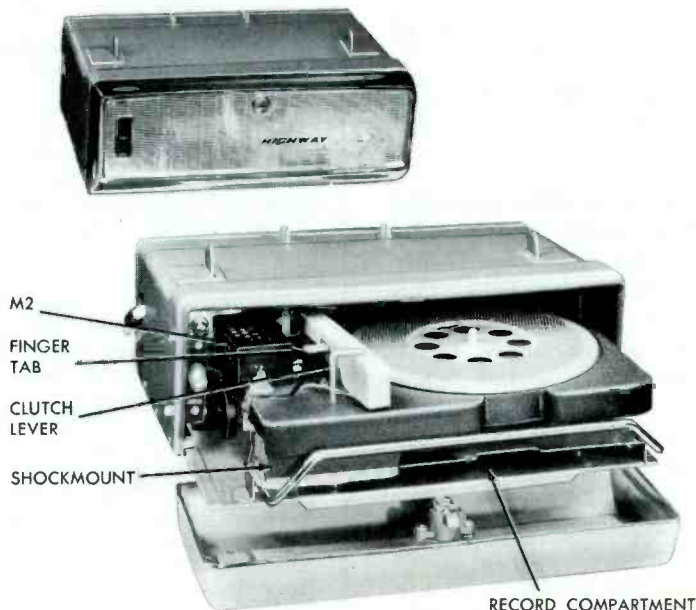

Fig. 4. Highway Hi-Fi Auto Record Player Announced by the Chrysler Corporation.



rubber shock mountings which will absorb most of the effects of sudden jars. The pickup and tone-arm arrangement is very different from that employed in conventional home phonographs in that the pickup and not the arm moves vertically.

The pickup assembly, which is mounted in the tone arm, is counterbalanced and pivots on a horizontal axis. A small spring attached to this assembly exerts a force of about 2.5 grams on the stylus as it rests on the record. This pressure prevents the stylus from having a tendency to bounce out of the record grooves when the auto is traveling over rough roads.

A fluid of a certain viscosity has been placed between the tone-arm bearing and its vertical shaft. This provides a precise amount of horizontal damping so that the tone arm will follow the motions of the car and at the same time track the fine grooves of the record. The manufacturer has conducted tests under very poor road conditions, and it was found extremely difficult to jar the stylus from the rec-

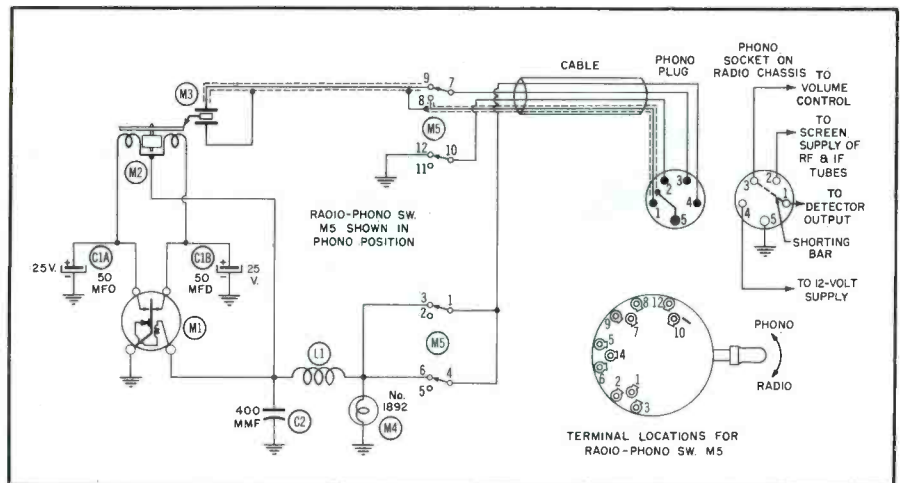

Fig. 5. Schematic Diagram of the Highway Hi-Fi Record Player.

ord grooves or to produce any audible disturbances.

The problem of frequent record changing was solved by the development of the new XLP records. These discs turn at only 16 2/3 rpm and have approximately 550 to 700 grooves per inch. This is twice the number of grooves and about one half the speed of conventional LP records. The signal output from the new records is roughly one half that of the LP records but

the signal-to-noise ratios of the two are practically equal.

Shure Brothers, Inc., produces a ceramic type of pickup especially designed for use in the Highway Hi-Fi tone arm. The output of this ceramic pickup is sufficient to drive the audio portion of the car radio without an additional pre-amplifier. The tip of the sapphire stylus used in the pickup has only a .3-mil radius. The small contact area of the stylus together with the

**SAVE TIME...**



on EVERY TELEVISION SERVICE CALL with the NEW

**Senco UNIVERSAL TV Jumper Cord**

Carry only one Jumper Cord for all TV Sets

- Extends Power from back of TV Set—no more moving of furniture to get to the wall plug
- Turn set off from rear
- No more winding and un-winding cords
- Two handy power outlets for soldering iron and test equipment
- Fits many speakers, focus coils, etc.

Write for illustrated Literature.

**SERVICE INSTRUMENTS COMPANY**  
ADDISON, ILL. (Chicago Industrial Suburb)  
In Canada: Emerald Television Corp., Montreal

COMPLETE \$1.95 DEALER NET  
Available at leading jobbers

**SOLD ONLY THRU DISTRIBUTORS**  
AN AMAZING NEW SERVICE TOOL...

at a Fantastically Low Price!

**BOSIPT**

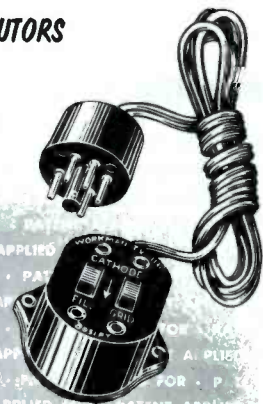

No more need for expensive, elaborate equipment to repair picture tubes. The convenient BOSIPT\* does the job in two minutes without removing the chassis. Easy to set up—easier to use, it repairs grid and cathode shorts in a jiffy. Increases emission, decontaminates cathodes, restores brightness control operation. There's no bulky testing case, no extra leads required.

\* Burns off shorts in picture tubes

PAYS FOR ITSELF — with the first use.

REPAIRS PICTURE TUBES — in the set.

GIVES LONGER PICTURE TUBE LIFE — to regular customers.

TWO MINUTE OPERATION — saves \$40 tube.

SIMPLE AND EASY TO USE — and fits into your kit.



**WORKMAN TV INC.**

TEANECK, N. J.

Manufacturers of Electronic SPECIALTIES

only \$3.57 DEALER NET

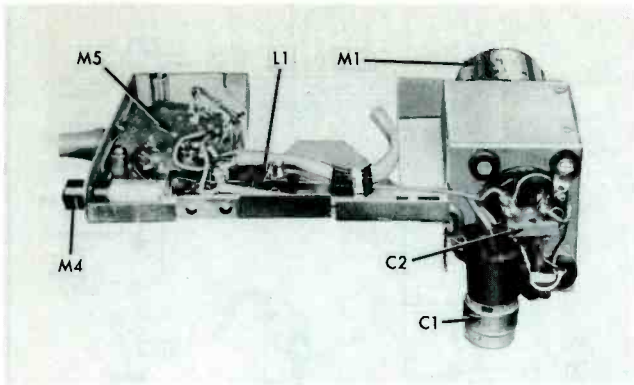

Fig. 6. Chassis Employed in the Highway Hi-Fi Record Player.

small amount of pressure applied between the stylus and the record will tend to reduce wear of the stylus considerably.

The problem of designing a phono-motor circuit which would operate at a constant speed from a car battery was overcome by use of a 60-cycle vibrator system. This circuit and that of the complete phono chassis are illustrated in the schematic diagram of Fig. 5. The phono motor M2 is an AC induction type, and the frequency of the input voltage governs the speed. Instead of the conventional 115-cycle vibrator, a 60-cycle unit M1 is used to furnish the phono motor with 18 volts rms at a pulsating rate of 60 cycles. The frequency of the vibrator is held relatively constant for fluctuations of battery voltage from 10 to 15 volts. This new vibrator circuit virtually eliminates wow which is often a result of an unregulated power supply.

The two 50-mfd capacitors C1A and C1B act as arc suppressors for the vibrator contacts. In addition, they change the shape of the voltage waveform at the contacts into an approximation of a sine wave so that the operation of the motor will be more efficient.

Two sections of the radio-phono switch M5 are paralleled to switch the 12-volt supply. The dial light

M4 is mounted on the front panel of the phono chassis directly above the radio-phono switch.

The output of the ceramic pickup is fed through the switch to the volume control and in turn to the AF amplifier and push-pull output stages of the radio. With the radio-phono switch in the phono position, the voltage is removed from the screens of the RF and IF amplifiers in the radio.

The shorting bar shown between terminals No. 1 and No. 3 of the phono socket on the schematic diagram is only connected when the car radio is installed without the phonograph. All components of the power chassis are marked in the photograph of Fig. 6.

The Highway Hi-Fi unit includes a record storage compartment for six records. The compartment is located in the bottom section of the player. See Fig. 4. When the player is pushed back into its case, a spring-loaded pressure plate secures the stored records. This also prevents the records from warping, which would be likely with the extreme temperature variations encountered in an automobile.

by LESLIE D. DEANE

## IN THE INTEREST OF QUICKER SERVICING (Continued from page 17)

turned on. The trouble started to show up in about a half hour; and 5 or 6 minutes later, it reached such a level that the technician turned the volume control down to minimum. This did not affect the hum, so it was known that the trouble was originating in the circuits that follow the volume control. Since the output tube was the most logical suspect, it was changed and the hum disappeared. The output tube was rechecked in the tube checker; and this time, it showed a gassy condition.

### Replacement of Obsolete Electromagnetic Focus Coils

Several times during the last year, TV receivers with open or shorted focus coils have been encountered. Replacement units for some of these defective coils were available; consequently, there was no problem about repairing those receivers. In one or two cases,

however, no replacement for the defective unit could be located. This presented somewhat of a problem because the customer wanted the receiver repaired.

Since the focus coils are used as part of the B+ filter or voltage-dropping networks in most receivers,

these coils cannot be eliminated but must be replaced with a suitable component. The replacement must be such that the same amount of filtering or decoupling will be accomplished. Referring to the schematic in Fig. 3, you will notice that the focus

Fig. 3. Schematic Diagram of Focus-Coil Circuit of TV Receiver.

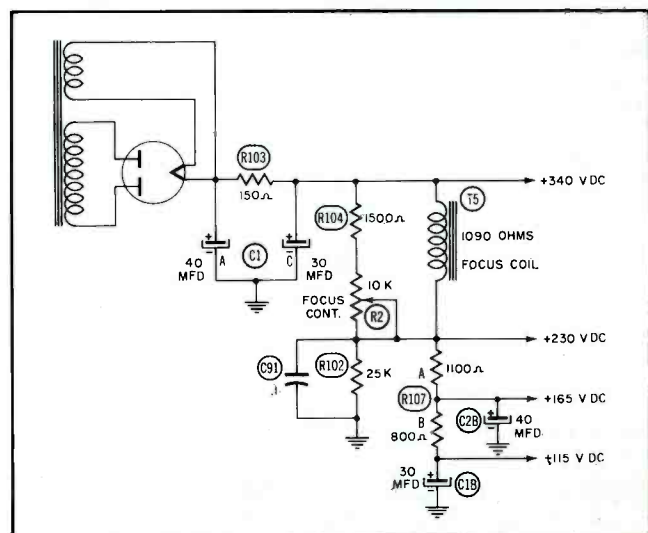

coil T5 is paralleled by the combination of R104 and the focus control. This parallel network serves to reduce the 340 volts to 230 volts under normal operation. Since it was not possible to obtain a replacement for the focus coil, a permanent-magnet focus assembly was obtained. It was necessary to make a mounting plate for the focus unit. This mounting plate was made of aluminum. (Any nonmagnetic material would have been suitable.)

The next problem was to install a component in place of the defective 1090-ohm coil in the B+ circuit. Since the focus control was not required, it was decided to remove the focus potentiometer R2 and the series resistor R104 from the circuit. To make this possible, it was necessary to determine the equivalent resistance of the network between the 340-volt and the 230-volt points. Since the value of the focus control at its maximum position is almost 10 times the value of R104, it can be assumed for all practical purposes that only R104 is in parallel with the focus coil T5. The equivalent resistance of this network is 630 ohms, as calculated by the formula:

$$\begin{aligned}
 R_{\text{equivalent}} &= \frac{R_1 \times R_2}{R_1 + R_2} \\
 &= \frac{1090 \times 1500}{1090 + 1500} \\
 &= 630 \text{ ohms.}
 \end{aligned}$$

Since the equivalent resistor will be located in the B+ voltage-dropping network and will be subjected to a considerable amount of heat generated by the current flowing through it, a 300-ohm resistor rated at 50 watts and a 350-ohm resistor also rated at 50 watts were connected in series to form approximately the required resistance. These units were mounted above the chassis for proper ventilation.

The construction of the aluminum mounting bracket and the mounting of the power resistors did take a great deal of time; but this work made it possible for the customer to continue using the TV receiver, a fact which pleased him.



## G-C RADIO-TELEVISION PRODUCTS

### AT YOUR DISTRIBUTOR

WRITE for your G-C Catalog or ask your supplier. FREE!

 <b>G-C TEST SOCKET ADAPTER KIT</b> Complete, for all tests. <b>No. 9250</b>	 <b>G-C VINYLITE CEMENT</b> Great adhesion; many uses; 2 oz. <b>No. 58-2</b>	 <b>G-C RADIO-TV SERVICE CEMENT</b> High grade adhesive. <b>No. 30-2</b>	 <b>G-C SPRA-KLEEN</b> Contact Cleaner <b>No. 8666</b>
 <b>G-C 300-OHM LINE TOOL</b> Slot, strip, cut twin leads. <b>No. 9220</b>	 <b>G-C DUAL SHEET METAL PUNCH</b> Two punches— $\frac{7}{8}$ " x $1\frac{1}{2}$ ". <b>No. 9260</b>	 <b>G-C DUAL TUBE PIN STRAIGHTENER</b> For both 7 and 9 pin tubes. <b>No. 9092</b>	 <b>G-C TV CHASSIS SUPPORTS</b> Tilt chassis safely. <b>No. 9176</b>
 <b>G-C ECONOMY TEST LEADS</b> Tenite 5' prods, 50" leads. <b>No. 9190</b>	 <b>G-C ALIGNMENT KIT</b> Roll case and 9 matched alignment tools. <b>No. 5023</b>	 <b>G-C K-27 PRINT-KOTE</b> Pressure spray silicone resin. <b>No. 14-6</b>	 <b>G-C SPRAY DE-OX-ID</b> Cleaner for radio, TV controls. <b>No. 19-6</b>

**GENERAL CEMENT MFG. CO.**      903 Taylor Avenue • Rockford, Illinois



## TRANS-CONDUCTANCE TUBE TESTER

### Also Tests Transistors

- Employs improved TRANS-CONDUCTANCE circuit. An in-phase signal is impressed on the input section of a tube and the resultant plate current change is measured. This provides the most suitable method of simulating the manner in which tubes actually operate in Radio & TV receivers, amplifiers, and other circuits. Amplification factor, plate resistance and cathode emission are all correlated in one meter reading.
- SAFETY BUTTON — protects both the tube under test and the instrument meter against damage due to overload or other form of improper switching.
- TESTS ALL TRANSISTORS—including NPN's, PNP's, Photo, Tetrodes, etc. Transistor quality is read on separate meter scale.

Model TV-12 comes housed in rugged portable case. Complete with all instructions — Only **\$7250** NET

Now at your local radio parts jobber.



**SUPERIOR INSTRUMENTS CO.**  
 2435 White Plains Road  
 New York 67, N. Y.

## ATLAS Cobra-Jectors

- wide angle dispersion
- indestructible fiber-glass
- all-weather construction

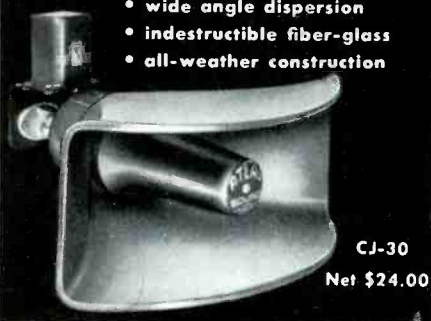

Weatherproof universal line transformer, \$5.10 Net.



Designed for wide angle coverage, paging, high efficiency intercom, sensitive talk-back. Tops in articulation. Convenient omnidirectional mounting bracket. In appearance, they're "beauts".

SPECIFICATIONS	CJ-30	CJ-14
Input pwr (cont.)	15 w	5 w
Input imp.	4 or 8 $\Omega$	4, 8 or 45 $\Omega$
Response (cps)	250-9,000	400-10,000
Dispersion	120° x 60°	120° x 60°
Bell Size	14" x 6"	9½" x 5½"
Over-all length	14"	8½"

Amazing "power packages"—use the Cobra-Jectors for the "tough" jobs.



WRITE FOR COMPLETE CATALOG  
**ATLAS SOUND CORP.**  
 1448—39 St., Bklyn. 18, N. Y.  
 In Canada:  
 Atlas Radio Corp., Ltd., Toronto, Ont.

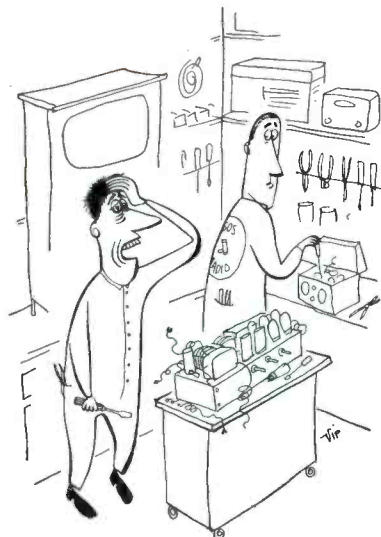

"I had a terrible night last night—dreamt we were out of JENSEN NEEDLES."

## Hints on Tubes

In recent months, there has been a steady release of new tubes that are more rugged and have higher ratings than do the tubes which they are designed to replace. Some examples are the 5U4GB and the 6CU6/6BQ6GTB. These tubes have different types of envelopes than their predecessors; and this difference in bulb design will make it impossible to use them in certain receivers.

The author recently had a service job on a 1954 Sylvania receiver that employs two 5U4G rectifiers mounted on a bracket above the power transformer. The differences in the base and bulb designs of the 5U4G and 5U4GB tubes made it impossible to use the 5U4GB in this receiver.

This event brought to mind the earlier Crosley receivers that employed two 6BQ6GT tubes in a small metal cage at the right rear of the chassis. The size of this cage makes it impossible to install two 6CU6 tubes as replacements and still be able to get the top on the cage.

There are probably other receivers in which these newer tubes

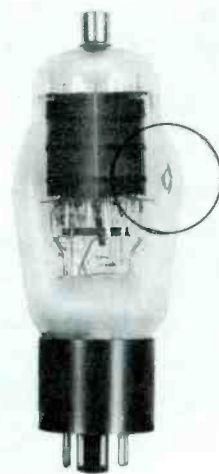

Fig. 4. A 6CD6G Tube with a Hole in Envelope.

will not fit for mechanical reasons; therefore, you should have at least two each of the 5U4G and the 6BQ6GT tubes in the tube caddy if you are to avoid having to make a special trip to the shop for a tube or tubes.

A technician friend brought in the tube which is shown in Fig. 4

the other day. You will notice the small hole in the side of the tube. This hole was caused when the high-voltage arced from the high-voltage lead to the plate of the tube. The tube, which had been in operation, was very hot; and the high-voltage arc was enough to puncture the bulb. A new tube was installed; and when the high voltage arced to the new tube, the technician taped the high-voltage lead and then coated it with corona dope. After this had dried, the lead was dressed away from the horizontal output tube; and there has been no further trouble from this source.

## Control of Line Voltage

In the September 1955 issue of the *PF REPORTER*, devices for adjusting the AC line voltage were dealt with in this column. The devices discussed were all of the nonautomatic type. Since that time, we have learned that automatic regulating devices are available and are in the same general price range. The CBC Regomatic, which is shown in Fig. 5, is one of



Fig. 5. CBC Regomatic Automatic Voltage Regulator Manufactured by the CBC Electronics Co., Inc., Philadelphia, Pa.

these units. It is available in two sizes: (1) Model 200 which will handle loads between 130 and 200 watts, and (2) Model 300 which will handle loads between 180 and 300 watts. The output of either unit is 115 volts AC  $\pm 3$  per cent when the input is between 95 and 130 volts. The automatic feature ensures the proper voltage to the TV receiver at all times.

CALVIN C. YOUNG

# SAMS INDEX TO PHOTOFACT FOLDERS

NO. 55: SETS NUMBER 1 THROUGH 310

**NOW! we'll send the SAMS INDEX TO PHOTOFACT  
direct to your shop at NO COST TO YOU**

Because so many thousands of our readers have asked us to make the SAMS INDEX TO PHOTOFACT available separately and apart from PF REPORTER, we have decided to provide it in a new and more handy form.

The SAMS INDEX will no longer appear in this magazine. Instead, it will be available from your Parts Distributor—or we

will send the SAMS INDEX direct to your own shop address—there's no charge—all you have to do is fill in and mail the coupon below.

We know you'll want to receive this valuable INDEX TO PHOTOFACT FOLDERS. It's your guide to the world's finest service data—covering over 20,000 TV and radio models. Get on our mailing list now.

Note: If you are a regular subscriber to PHOTOFACT Folders, you will continue to receive the SAMS INDEX with your Folder sets.

## HOWARD W. SAMS & CO., INC.

Howard W. Sams & Co., Inc.  
2201 East 46th Street, Indianapolis 5, Indiana  
Gentlemen:

Enter my name on your mailing list to receive the SAMS INDEX TO PHOTOFACT FOLDERS. I understand there will be no charge for this service.

I am a Service Technician: \_\_\_\_\_ full time; \_\_\_\_\_ part time.

Student. Other: \_\_\_\_\_

Shop Name \_\_\_\_\_

Att'n of: \_\_\_\_\_

Address \_\_\_\_\_

City \_\_\_\_\_ Zone \_\_\_\_\_ State \_\_\_\_\_

... following a set number in the Index listing, indicates a "Preliminary Data Folder." These Folders were designed to provide immediate basic data on TV receivers. Many of these were later superseded by regular PHOTOFACT Folders. In those cases where short production runs and/or later inventions have replaced the "A" data...

2. The letter number in the schematic on schematics is coverage on they reach the majority of later in present that w ay d CT

**MAIL COUPON TODAY  
GET THE SAMS INDEX  
DELIVERED RIGHT  
TO YOUR SHOP...**

FOR MORE

CURRENT ON

56: Keep the latest SAMS INDEX handy always . . .

**INDEX TO ADVERTISERS**

March, 1956

- 1Q. B & K (B & K Manufacturing Co.)**  
Informative article titled: "Profitable TV Servicing in the Home," by Henry Gronski, General Manager of Central Television Service, Chicago. Also Bulletin No. 500 on newest B & K Dynamic Mutual Conductance Tube Tester, and Bulletin No. 104 on CRT Cathode Rejuvenator Tester. *See advertisement page 30.*
- 2Q. BLONDER-TONGUE (Blonder-Tongue Labs., Inc.)**  
New TV Equipment Catalog and TV Technical Bulletins on TV Systems and Industrial TV. *See advertisement page 55.*
- 3Q. BUSSMANN (Bussmann Mfg. Co.)**  
Bulletin showing fuses and fuse-holders adapted to protection of TV and other electronic equipment (Form SFB). *See advertisement page 4.*
- 4Q. CENTRALAB (Centralab, Division of Globe-Union, Inc.)**  
Catalog sheet 42-223 describing Centralab Fastatch Dual Control Kit. The kit contains 22 Fastatch units covering 80% of dual controls used by major TV manufacturers. *See advertisement pages 51, 53.*
- 5Q. CLAROSTAT (Clarostat Mfg. Co., Inc.)**  
Form No. 751773 Sound Systems Controls. Audio applications L & T pads. *See advertisement page 5.*
- 6Q. CORNELL-DUBILIER (Cornell-Dubilier Electric Corp.)**  
CDR TV Antenna Rotors Catalog CF904D. *See advertisement page 65.*
- 7Q. GERNSBACK (Gernsback Publications, Inc.)**  
Descriptive literature on the Gernsback Library Books. *See advertisement page 73.*
- 8Q. HICKOK (Hickok Electrical Instrument Co.)**  
New 24-page Test Equipment Catalog No. 30. New 20-page Form TTC Tube Tester Book of Facts. *See advertisement page 42.*
- 9Q. HUNTER (Hunter Tool Co.)**  
New Electronic Tool Catalog showing complete line of Electronic Tools. *See advertisement page 71.*
- 10Q. HYCON (Hycon Electronics, Inc.)**  
Comprehensive Folder on latest Hycon Test Instruments and Accessories. *See advertisement page 38.*
- 11Q. INTERNATIONAL RECTIFIER (International Rectifier Corp.)**  
Bulletin JRP-4. Catalog listing complete line of company's selenium rectifiers, germanium and selenium diodes and selenium photo-electric cells. *See advertisement page 78.*
- 12Q. IRC (International Resistance Co.)**  
New PW7 and PW10—Power wirewound Resist-O-Cards—S502A. *See advertisement 2nd Cover.*
- 13Q. MALLORY (P. R. Mallory & Co.)**  
New comprehensive Mallory Vibrator Guide, just off the press. Complete cross-reference information. *See advertisement pages 40, 41.*
- 14Q. MOSLEY (Mosley Electronics, Inc.)**  
New Catalog No. 56TV Installation Accessories. *See advertisement page 72.*
- 15Q. RMS (Radio Merchandise Sales, Inc.)**  
Descriptive literature on the new RMS "Big Shot" all-channel Yagi. *See advertisement page 75.*
- 16Q. RAM (Ram Electronics Sales Co.)**  
FREE 1956 RAM TV Field Service Manual PF-3 features "PIX-A-FAULTS," "TROUBLE-FACTS," Circuit Diagrams, plus COMPLETE cross-reference replacement listings for fly-backs, yokes, vertical osc. and output xmfrs, linearity and width coils—all authentic recommendations from TV manufacturers' specifications. *See advertisement page 73.*
- 17Q. SECO (Seco Manufacturing Co.)**  
Folders and Catalog Sheets. Seco-Monitron—Signal Tracer and Intermittent Localizer. *See advertisement page 60.*
- 18Q. SPRAGUE (Sprague Products Co.)**  
K-200 Ceramic TV Replacement Capacitor Manual. *See advertisement page 2.*
- 19Q. TARZIAN (Sarkes Tarzian, Inc.)**  
Sarkes Tarzian Selenium Rectifier Handbook; Selenium Rectifier Replacement Guide; Silicon Rectifier Booklet; High Temperature Selenium Rectifier Brochure. *See advertisement page 44.*
- 20Q. TRIAD (Triad Transformer Corp.)**  
Catalog TV-55, Triad Correct Replacement TV Guide, listing Triad Correct Replacement Television Transformers. *See advertisement page 70.*
- 21Q. TRIPLETT (Triplett Electrical Instrument Co.)**  
Sixteen-page Test Equipment Catalog. *See advertisement page 35.*
- 22Q. UNIVERSITY (University Loudspeakers, Inc.)**  
Brochures No. 78A8, No. 78A32, No. 78A1, and No. 78A2, on various phases of loud-speaker problems, such as "Decor-Coustic Speaker System," "University Do-It-Yourself Projects," and others. *See advertisement page 75.*
- 23Q. VACO (Vaco Products Co.)**  
Catalog on Vaco Screw-drivers, Nut-drivers, Pliers, Wood Chisels and Tool Kits. *See advertisement page 56.*
- 24Q. WALSCO (Walsco Electronics Corporation)**  
Complete Technical Data on Walsco Wizard TV Antenna with new, exclusive "PHASE REVERSER." Walsco Bulletin No. 210. *See advertisement page 22.*
- 25Q. WELLER (Weller Electric Corp.)**  
Catalog on new Weller Model 8100K Complete Soldering Kit. *See advertisement page 54.*
- 26Q. WINSTON (Winston Electronics, Inc.)**  
Specifications of Sweep Circuit Analyzer and Technical Information on use of Win-Tronix Color Test Equipment. *See advertisement page 57.*

Advertisers	Page No.
Aerovox Corp.	31
American Phenolic Corp.	34
Astron Corp.	28
Atlas Sound Corp.	82
B & K Mfg. Co.	30
Belden Mfg. Co.	8
Blonder-Tongue Labs, Inc.	55
Bud Radio, Inc.	58
Bussmann Mfg. Co.	4
Centralab, A Div. of Globe-Union, Inc.	51, 53
Chicago Standard Trans. Corp.	6
Clarostat Mfg. Co., Inc.	5
Cornell-Dubilier Electric Corp.	65
DuMont Labs., Inc., Allen B.	32
Electro Products Labs.	69
Electronic Instrument Co., Inc. (EICO)	68
Electronic Pub. Co., Inc.	70
Erie Resistor Corp.	61
General Cement Mfg. Co.	74, 76, 81
Gernsback Library, Inc.	73
Hickok Electrical Instrument Co.	42
Holloway Electronics	16
Hunter Tool Co.	71
Hycon Mfg. Co.	38
International Rectifier Corp.	78
International Resistance Co.	2nd Cover
Jackson Electrical Instr. Co.	65
Jensen Industries, Inc.	82
Jensen Mfg. Co.	39
Littelfuse, Inc.	4th Cover
Mallory & Co., Inc., P. R.	40, 41
Merit Coil & Trans. Co.	77
Mosley Electronics Inc.	72
Permo, Inc.	66
Phaostron Co.	52
Planet Sales Corp.	72
Pyramid Electric Co.	36
Quietrol Co.	75
Radiart Corp.—Cornell-Dubilier Electric Corp.	1
Radio Corp. of America	14, Third Cover
Radio Merchandise Sales, Inc.	75
Ram Electronics Sales Co.	73
Raytheon Mfg. Co.	7
Sams & Co., Inc., Howard W.	50, 64, 83
Sangamo Electric Co.	45
Seco Mfg. Co.	60
Service Instruments Co.	79
Shure Bros., Inc.	69
Sprague Products Co.	2
Stackpole Carbon Co.	46, 47
Superex Electronics	73
Superior Instruments Co.	81
Sylvania Electric Products Inc.	26
Tarzian, Inc., Sarkes	44
Technical Appliance Corp.	43
Triad Transformer Corp.	70
Triplett Electrical Instr. Co.	35
Tung-Sol Electric Inc.	62, 63
Ungar Electric Tools, Inc.	59
University Loudspeakers, Inc.	75
V-M Corp.	48
Vaco Products Co.	56
Vokar Corp.	67
Walco-Electrovox Co., Inc.	74
Walsco Electronics Corp.	22
Weller Corp.	54
Winston Electronics, Inc.	57
Workman TV, Inc.	79
Xcelite, Inc.	66

While every precaution is taken to insure accuracy, we cannot guarantee against the possibility of an occasional change or omission in the preparation of the REPORTER.



## "BACKGROUND QUIETNESS"

*... for new "front-end" performance!*

**A MAJOR ENGINEERING FEATURE OF RCA RECEIVING TUBES**

Known for their ability to hold tube noise to surprisingly low levels—and produce a cleaner TV picture for the customer—RCA Receiving Tubes are making even more friends with servicemen the country over.

Take a few of the improvements that contribute to background quietness in the famous "front-end" tube—the RCA-6BQ7A: Gold-plated grids reduce reverse grid current; extra heater-to-cathode insulation lowers leakage current and reduces hum; larger grid and cathode connectors minimize "induced" grid noise... features that can give new "front-end" performance!

For increased "background quietness" and a cleaner picture, always replace with RCA Receiving Tubes—and say goodbye to costly callbacks.



**RECEIVING TUBES**  
RADIO CORPORATION OF AMERICA

# ELECTRONIC SPECIALISTS



HILTON BROWN ADVERTISING

Inventors of the electronic fuse, Littelfuse has pioneered every major development in standards of electronic circuit protection. Littelfuse has also created and produced in its more than 28 years literally thousands of special and complex electronic items. Littelfuse engineering advice is always available on special or standard applications for automotive, aircraft or electronic circuit protection.

# LITTELFUSE

DES PLAINES, ILL.