

*Howard W. Sams*

**PF**  
PHOTOFACT<sup>®</sup>

**INDEX**

JUNE • 1954

the monthly  
**REPORTER**  
for the *ELECTRONIC*  
*SERVICE INDUSTRY*

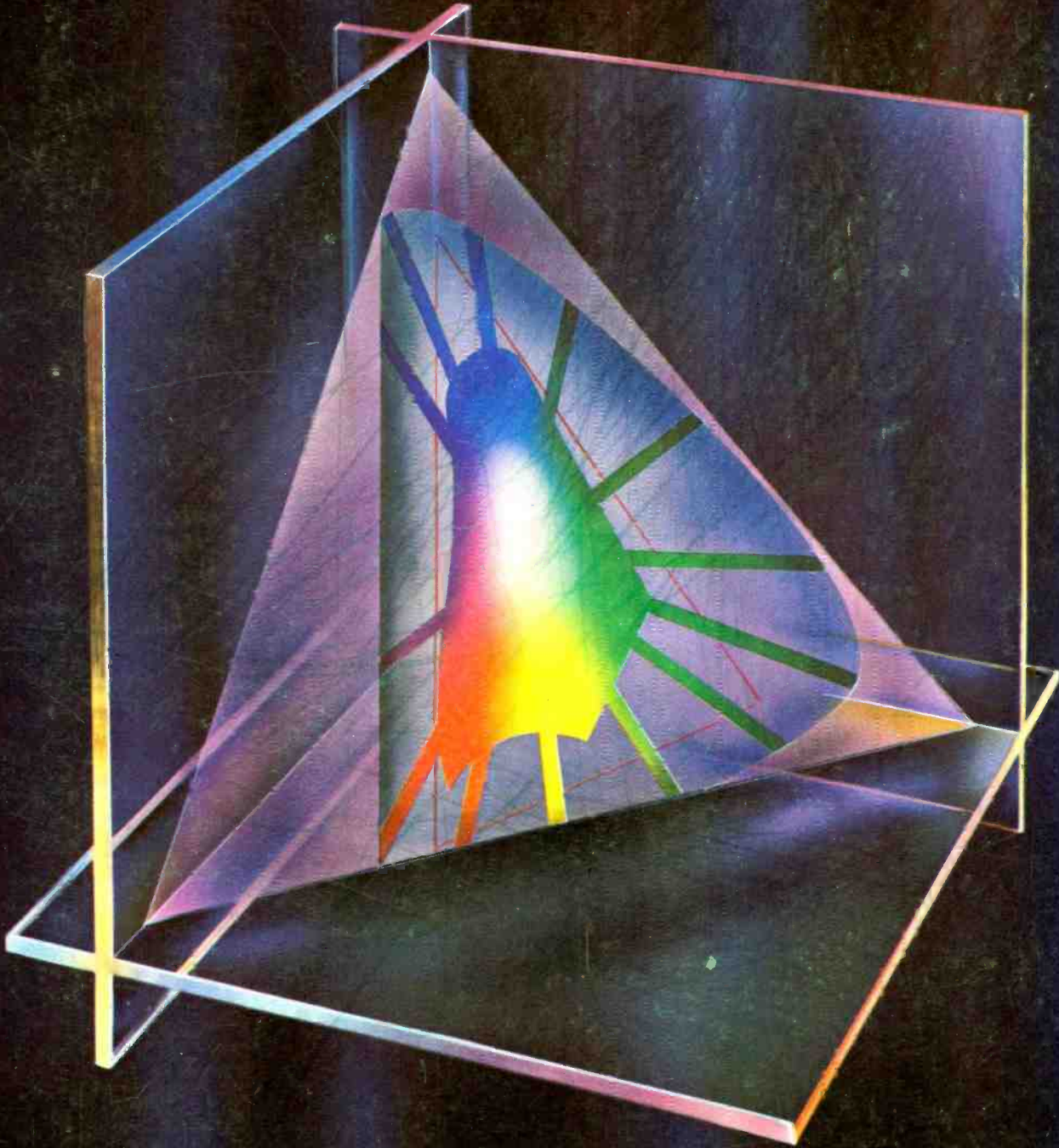

**Colorimetry**

# ASSURED ELECTRICAL ACCURACY

# BASED ON MANUFACTURERS' PROCUREMENT PRINTS

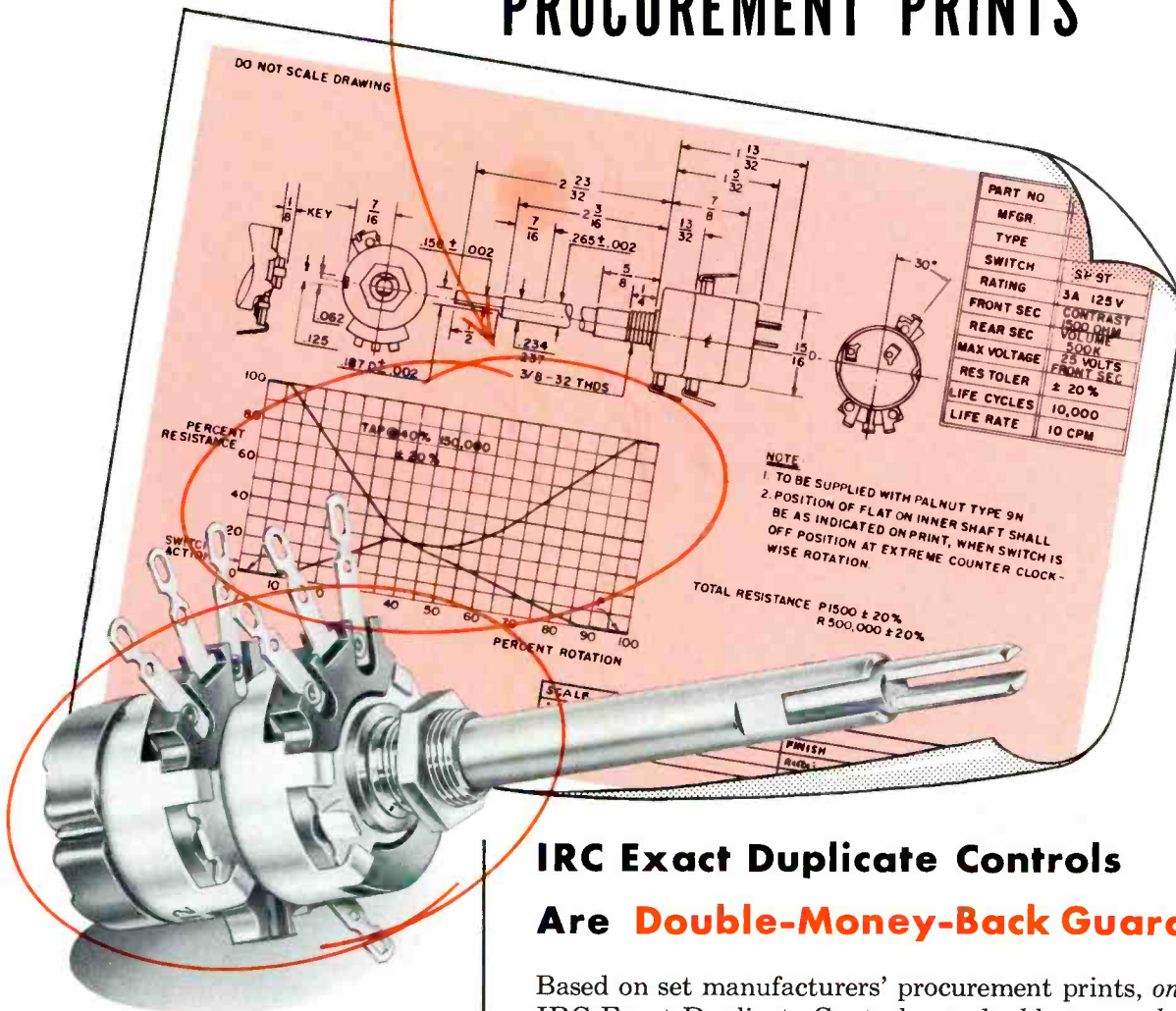

**ONLY IRC GUARANTEES**  
**ACCURATE ELECTRICAL OPERATION**  
**AND SATISFACTORY MECHANICAL FIT**  
**OR DOUBLE-YOUR-MONEY-BACK**

Electrical specifications of this typical manufacturer's procurement print are exactly duplicated by IRC's QJ-412 control (shown). CONCENTRIKIT assembly includes P1-206 and R1-223 shafts with B17-109 and B13-133X Base Elements and 76-1 Switch.

## IRC Exact Duplicate Controls Are Double-Money-Back Guaranteed

Based on set manufacturers' procurement prints, *only* IRC Exact Duplicate Controls are double-money-back guaranteed for accurate electrical operation. This firm guarantee applies to both IRC factory-assembled Exact Duplicates *and* universal CONCENTRIKIT equivalents.

Set manufacturers' electrical specifications are closely followed.

Resistance values are carefully selected to match.

Tapers are watched carefully; IRC doesn't arbitrarily substitute tapers to obtain wide coverage.

For exact duplicate controls of guaranteed accuracy, specify IRC. Most Service Technicians do.



Wherever the Circuit Says ~~~

## INTERNATIONAL RESISTANCE CO.

423 N. Broad Street, Philadelphia 8, Pa.

In Canada: International Resistance Co., Ltd., Toronto, Licensee



EDWARD A. GURTOWSKI  
1452 KENHORST BLVD.  
KENHORST, READING, PA.  
Phone 4-3508

# bases loaded *you're at bat*

GET ON REGENCY'S LEAGUE LEADING TEAM  
RUN HOME WITH THE MONEY

Make increased profit with Regency's TV accessories

*Regency* Division of I.D.E.A., INC.



**RC-53  
UHF CONVERTER**  
\$19<sup>95</sup> List

The only 19.95 converter  
fully transformer powered.  
AC only. Underwriters  
Approved



**DB550  
CASCADE TWO-STAGE VHF BOOSTER**  
\$37<sup>50</sup> List

You cannot miss with Regency DB550! TV picture improvement  
absolutely guaranteed where improvement is needed.



**RT-700  
CHAIRSIDE TV CONTROL**  
\$69<sup>95</sup> List

For those who can afford the best of everything—improved  
reception plus chairside TV control.  
Cascode tuner changes channels, sharpens contrast, and controls  
volume as far as 100 feet away from set.  
Less than 30 minutes to install.

MAKERS OF VHF BOOSTERS, UHF CONVERTERS, PROFESSIONAL HIGH FIDELITY EQUIPMENT AND TELEVISION REMOTE CONTROL.



*OF COURSE I'M A DEPENDABLE  
CREDIT RISK. I ALWAYS  
INSIST ON SPRAGUE CAPACITORS.*

## Don't Be Vague... Insist on SPRAGUE



### Insist on Sprague KWIK-TEST

Save hours of time and trouble checking capacitors right in the circuit for opens, shorts, intermittents, without unsoldering leads. No wonder it pays for itself in no time! An ideal supplement to the Sprague Tel-Ohmike® capacitor-resistor analyzer, the Model KT-1 Kwik-Test is priced at only

**\$34.50**  
NET

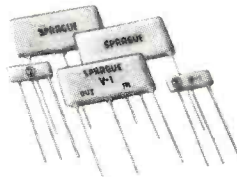

### Insist on Sprague BULPLATE® PRINTED CIRCUITS

When you ask for Bulplate printed circuits, you know you're getting the most compact units available. These ruggedly built, amazingly tiny units fit the tightest spaces with ease, and save repair time to boot.



### Insist on Sprague TWIST-LOK® 'LYTICS

Sprague TVL's fill the top performance bill in the toughest TV circuits. High temperatures, surge voltages, ripple currents won't faze them. Like all Sprague capacitors, Twist-Lok 'Lytics are your first line of defense against expensive call-backs.

Accept no substitutes. There is a Sprague Distributor in every sales area in the United States. Write for the name of your nearest source of supply today.

☆ Trademark

# SPRAGUE

Get your copy of Sprague's latest radio and TV service catalog C-610. Write Sprague Products Company\*, 105 Marshall St., North Adams, Mass.

\*Distributors' Division of Sprague Electric Company

**WORLD'S LARGEST  
CAPACITOR MANUFACTURER**

JAMES R. RONK  
*Editor*  
LESTER H. NELSON  
*Managing Editor*  
W. WILLIAM HENSLER  
*Technical Editor*

*Editorial Staff*  
PHYLLIS J. AUKERMAN  
GWEN BIGHAM  
WILLIAM E. BURKE  
HENRY A. CARTER  
ROBERT B. DUNHAM  
JAMES M. FOY  
DON R. HOWE  
FRED McKINNEY  
GLENN A. McROAN  
EVELYN S. MOUSER  
MARGARET NEFF  
C. P. OLIPHANT  
VERNE M. RAY  
GLEN E. SLUTZ  
PAUL C. SMITH  
CALVIN C. YOUNG, JR.  
ANTHONY M. ANDREONE  
GLENN R. SMITH  
*Art Directors*  
ROBERT W. REED  
*Photography*  
ARCHIE E. CUTSHALL  
DOUGLAS G. BOLT  
HARRY A. MARTIN  
*Production*

★  
**HOWARD W. SAMS**  
*Publisher*

*Business Department:*  
Donald B. Shaw, V. P.  
*Treasurer*  
F. T. Dobbs, Secretary  
Joe H. Morin, Sales Mgr.  
Ann W. Jones, Advertising  
Shirley A. Owens, Literature  
*Service Mgr.*  
J. C. Keith, V. P.  
*Charge of Circulation*

Printed by  
THE WALDEMAR PRESS  
Joseph C. Collins, Mgr.

*Eastern Representatives*  
Paul S. Weil and  
Donald C. Weil  
39-01 Main Street,  
Flushing 54, New York  
Independence 3-9098

*Howard W. Sams*  
**PF INDEX**

the monthly  
**REPORTER**  
for the **ELECTRONIC**  
**SERVICE INDUSTRY**

VOL. 4 • NO. 6

JUNE • 1954

**CONTENTS**

Shop Talk . . . . .	Milton S. Kiver	5
Television Sound IF Systems (Part II) . . . . .	Paul C. Smith	7
Color TV Training Series (Part I) . . . . .	C. P. Oliphant	9
Notes on Test Equipment . . . . .	Paul C. Smith	13
Horizontal AFC Circuits (Part II) . . . . .	William E. Burke	15
TV Colormath (Part II) . . . . .	Harold E. Ennes	17
Examining Design Features . . . . .	Don R. Howe	21
In the Interest of Quicker Servicing . . . . .	Henry A. Carter	25
Audio Facts . . . . .	Robert B. Dunham	27
Dollar and Sense Servicing . . . . .	John Markus	31
A Stock Guide for TV Tubes . . . . .		71
Status of TV Broadcast Operations (Supplement No. 1) . . . . .		77
+ More or Less — . . . . .		80
Photofact Colorblock Reference Chart No. 1 . . . . .		Insert

**SUBJECT REFERENCE**

<b>AUDIO</b>	<b>TELEVISION</b>
Supplying DC for Tube Filaments . . . . . 27	AFC or Phase Comparator Tube . . . . . 50
<b>COLOR TV</b>	Crosley Model G-17TOMH Chassis 426 . . . . . 21
Chrominance Modulation . . . . . 19	Foster-Seely Discriminator . . . . . 33
Colorimetry . . . . . 9	Gated-Beam Tube . . . . . 37
Convergence Adjustments . . . . . 13	Pulse-Width Type of Horizontal AFC System . . . . . 15
Luminance and Chrominance Band Sharing Modulation Levels of the Composite Color Signal . . . . . 17	Ratio Detector . . . . . 35
<b>RADIO</b>	<b>TEST EQUIPMENT</b>
Flush Wall Radio Model 5P . . . . . 69	Hickok 650C Videometer . . . . . 13
<b>SERVICING</b>	Jackson CRO-2 Oscilloscope . . . . . 73
Listing Service Histories . . . . . 5	Radio City Products Co., Model 123 Flybacker . . . . . 74
Ratio Detectors . . . . . 65	Triplett Model 631 Multimeter . . . . . 75
Sound Discriminators . . . . . 64	
Test Socket Adapters . . . . . 65	
Video Detectors . . . . . 25	

Copyright 1954 by Howard W. Sams & Co., Inc.  
No part of the PF INDEX may be reproduced without written permission. No patent liability is assumed with respect to the use of information contained herein.

The PF INDEX is published monthly by Howard W. Sams & Co., Inc., 2201 East 46th Street, Indianapolis 5, Indiana. The PF INDEX is on sale at 25¢ a copy at 1093 jobbers of Electronic Parts throughout the United States and Canada. (In Canada 30 cents.) When available, back numbers may be obtained by sending 35¢ for each copy desired. Acceptance under Section 34.64 P. L. & R. authorized at Indianapolis, Indiana  
**SUBSCRIPTION DATA:** For those desiring the convenience of delivery to their homes or shops, each issue of the INDEX will be mailed direct, promptly upon publication. The subscription charge is \$4.00 annually in the United States and U. S. possessions.



**customers enjoy  
"PROFESSIONAL TREATMENT"**

In television service as in any profession, whether it be barber or doctor, the client places great emphasis on the way you go about your business. Professional treatment of the customer creates confidence in your service and ultimately results in his satisfaction.

One way to insure this customer good will in TV service is to combine top-quality materials with your skilled, technical, workmanship. With dependable products, you can eliminate costly call-backs and build a reputation for quality service.

You can depend on Du Mont quality picture tubes to do more for your service.



Photo by Joe Clark, H. B. S. S. from Friends Magazine and Photography Magazine.

**Replacement Sales Cathode-ray Tube Division**

**ALLEN B. DU MONT LABORATORIES, INC.**

750 Bloomfield Avenue, Clifton, N. J.

**PIONEER IN BIG PICTURE TUBES • ORIGINATOR OF THE FAMOUS BENT-GUN AND SELFOCUS  
LEADER IN HIGH-RESOLUTION • MAJOR SUPPLIER TO MOST FINE TELEVISION RECEIVER MANUFACTURERS**

\* TRADE MARK

# ShopTalk

**MILTON S. KIVER**

*President, Television Communications Institute*

The main job with which the service technician is concerned is that of repairing electronic equipment. The skill he exhibits is dependent upon several factors such as his training, equipment, and facilities.

There are several things which the technician can do to improve his servicing techniques. Of great importance is the task of keeping abreast of current receiver design. Technical articles and production-change bulletins can be very instrumental in fulfilling this need. The big problem arises in finding the time to study such material. There are limits to the amount of material a service technician can retain in his mind, and this indicates that a need exists for some means of cataloguing such information. It is also quite helpful to keep records of servicing experiences. If this is done, such information can be very useful when receivers having certain symptoms are being serviced.

Here is a system for recording this information while carrying on your regular service work. After a set has been fixed, a brief note is made in a loose-leaf binder or on a large card under an appropriate heading. The trouble is indicated in the heading, and its causes are listed below in a semi-general manner rather than on a specific set-by-set basis.

The best way to illustrate the system is by way of an example using the sound system of a television receiver. In intercarrier receivers, audible sync buzz in the sound system is a common complaint. A service technician called upon to repair a set exhibiting this symptom first asks himself, "What is the most probable cause of this trouble?"

To bring this information to our finger tips, we make up a list of those defects which we ourselves have

found to be the cause of audible sync buzz. To this we also add possible causes as indicated by the experience of other service technicians. Much of this latter information could come from magazines. The list could be placed on one page of the loose-leaf binder or on the card and be given the heading "Sync Buzz." Every time we service a set containing sync buzz, mention is made of the reason (in a general way) on the list. Furthermore, every time after the first time that we meet the same trouble we place a tally mark next to it on the chart. This tabulation, over a period of time, not only tells us what most of the causes of sync buzz are but also — and this is most important — which of these occur most frequently.

There is very little work attached to making and then maintaining the list. For example, most of the causes for sync buzz in television receivers may be listed as follows:

1. Misadjustment of the ratio-detector transformer.
2. Misalignment of the sound IF system, including the ratio-detector transformer.
3. Overloading because of excessive signal strength.
4. Overloading because of insufficient AGC voltage.
5. Poor lead dress.
6. Capacitive coupling between the sync-separator system and the audio system.
7. Vertical sync pulses reaching the AGC line.
8. Defective B+ filter capacitor which allows vertical pulses from the vertical system to reach the audio system.

9. Poor design.

10. Troubles at the transmitting station.

These ten items probably account for over 95 per cent of the sync buzz heard in television receivers. No attempt has been made to list these in any order although, as it happens, the first one happens to be one of the most frequent reasons for sync buzz. This fact would become increasingly evident to you as time went on, because this item would have more tally marks next to it than any of the other items on this list.

The method is simple, it requires very little of your time, and it is adaptable to a one-man shop or to an entire organization. In large firms, each man is usually required to fill out a customer-service card; and the cause of the trouble will appear on it. One man, or even an office girl, can then be given a job of entering this information on the appropriate list.

The completeness with which you draw up the list depends upon how ambitious you are. For example, if one type of circuit or one manufacturer is particularly prone to one type of trouble, by all means make a note of it right on the chart. The note need not be extensive; simply place the name of the circuit or manufacturer's set next to the related item. This will keep you on the alert for similar trouble in the same circuit and, at the same time, place the entire list in front of you for quick reference in case the cause lies elsewhere in the set.

As long as we are using the sound system as our example, we can treat other troubles and their probable causes in a similar manner. Thus, under the heading of "Weak

\* \* Please turn to page 59 \* \*

**Do a Lot...  
With  
a Little**

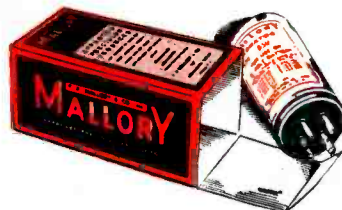

***Cover 75% of Your Replacement Needs  
with Just 6 Mallory Vibrators***

You don't need a large inventory when you rely on Mallory Vibrators for your replacement work. A selection of just six Mallory Vibrators gives you coverage of 75% of your jobs.

And you can use Mallory Vibrators with complete confidence that their performance will satisfy you . . . and your customers. Mallory not only made the first commercial vibrator but supplies more to set makers than all other manufacturers combined.

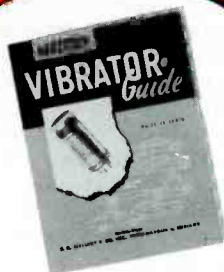

**Do It Faster...**

You speed selection of the right Vibrator for any job when you use the current Mallory Vibrator Guide. It's your complete cross-reference and service guide. See your Mallory Distributor about this handy book . . . or write P.O. Box 1558, Indianapolis 6, Indiana.

P. R. MALLORY & CO. Inc.  
**MALLORY**

**CAPACITORS • CONTROLS • VIBRATORS • SWITCHES • RESISTORS  
RECTIFIERS • POWER SUPPLIES • FILTERS • MERCURY BATTERIES  
APPROVED PRECISION PRODUCTS**

**P. R. MALLORY & CO. Inc., INDIANAPOLIS 6, INDIANA**



# TELEVISION SOUND

## IF systems

### Part II

### Several Methods of FM Detection Used in Television Receivers

by PAUL C. SMITH

This is the second part of an article which first appeared in the May issue of the PF INDEX. Part I contained a discussion of the two basic types of sound IF systems used in television receivers, namely intercarrier and nonintercarrier systems. The various methods of achieving sound take-off were illustrated, and the action of limiters was described in detail. The interstage coupling devices employed in sound IF strips were pointed out as were other design characteristics of the strips.

Part II begins with a description of the principal methods used to achieve FM detection in television receivers.

#### FM Detection

One of the simplest methods of FM detection is commonly called "slope detection." Fig. 10-11 shows the response curve of a tuned resonant circuit, possibly an IF transformer, with relative amplitude plotted against frequency. If the FM intermediate-frequency signal is applied and if the circuit is tuned to resonance at a frequency slightly

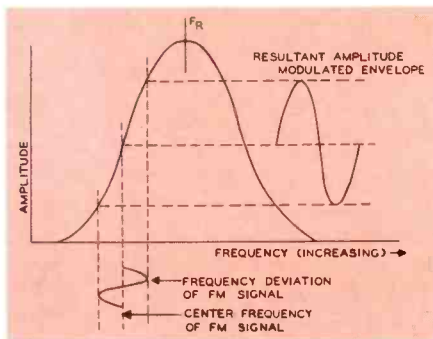

Fig. 10-11. Frequency Demodulation Using Slope of IF Response Curve.

different from the intermediate frequency, the signal will fall on the slope of the response curve. As the frequency of the FM signal rises, the signal output will increase in amplitude; and as the frequency falls,

the signal output will decrease. Thus, we have the output signal varying in amplitude in a manner corresponding to the frequency variations of the input. These amplitude variations may then be detected in the usual manner by a diode detector.

Similar results would be obtained if the other slope of the IF response curve were used. Certain factors limit the usefulness of this method: nonlinearity of the response curve introduces distortion, the usable portion of the curve is small, and the circuit responds to amplitude variations in the input.

\* \* Please turn to page 33 \* \*

Fig. 10-13. Conventional Foster-Seely Discriminator Circuit With Vector Diagrams Illustrating Principle of Operation.

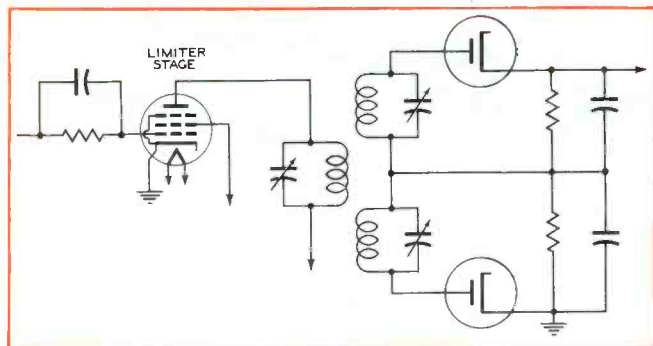
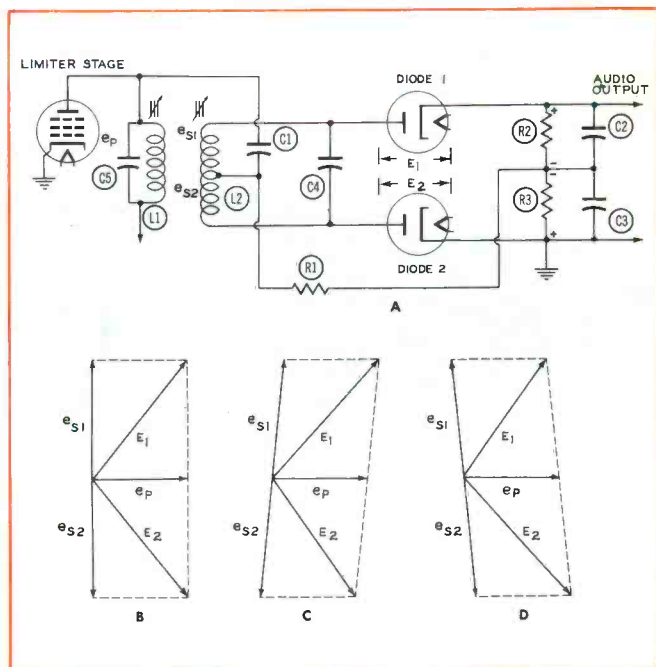

Fig. 10-12. Triple-Tuned Discriminator Circuit.

# CAN YOU HANDLE 7 DAYS' WORK IN 6 NEXT YEAR?

**G.E. SHOWS YOU HOW—with a field-tested plan that has helped hundreds of other TV-radio service dealers. Only plan of its kind in the industry!**

**A**UTHORITIES agree that the normal growth of the TV-radio service industry can bring an increase in your business next year equal to one extra day's work a week. To get your full, profitable share of this new business, you need to organize *now* for top efficiency.

- How to begin, what to do, and how: these questions are answered for you in G.E.'s new **SUCCESSFUL SERVICE MANAGEMENT**. It's a complete plan for improving and strengthening your methods, with accounting, merchandising, and technical helps that service dealers from coast to coast have tested and found successful. If available commercially, this plan would cost you a substantial sum.
- General Electric, however, has made the investment in money and research—its purpose, to *help you help yourself* by becoming a better businessman. Know where you stand financially! Make every advertising and promotion dollar pay ample returns! Stay ahead of competition in technical knowledge! You can do these things by using **SUCCESSFUL SERVICE MANAGEMENT** to full advantage. See your G-E tube distributor!  
*Tube Dept., General Electric Co., Schenectady 5, N. Y.*



## NEXT YEAR?

**EVERYTHING** you need to set up an organized and efficient service business is included in G.E.'s **SUCCESSFUL SERVICE MANAGEMENT**. You learn step-by-step how to manage your—

**BUSINESS PRACTICES** . . . Are you sure you're making money? . . . Accounting for the TV-radio service dealer (a complete course, with all records and how to keep them) . . . Preparing your income-tax return.

**MERCHANDISING** . . . Why advertise, why promote? . . . Identification . . . Advertising . . . Direct-mail . . . Window and store display . . . other ways to increase sales.

**TECHNICAL ACTIVITIES** . . . TV troubleshooting with an oscilloscope . . . Alignment techniques . . . U-h-f servicing . . . other technical instruction, all detailed in its treatment and fully illustrated.

Plenty of operating examples make it easy to understand and apply **SUCCESSFUL SERVICE MANAGEMENT**. Instruction is down-to-earth and practical. For the first time, you have in compact form both an aid to scientific operation of your business, and a guide to healthy future growth.

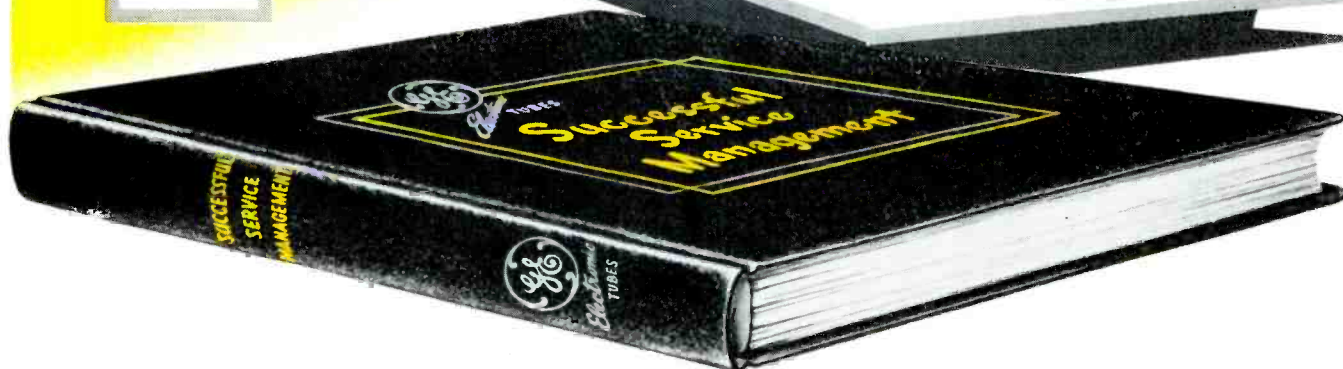
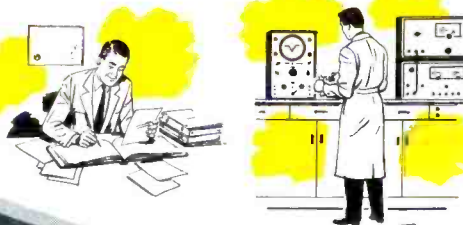

**GENERAL**  **ELECTRIC**

161-1A6

# COLOR TV

## TRAINING SERIES

### Part I COLORIMETRY The Science of Determining and Specifying Colors

by C. P. Oliphant

It is advisable for the service technician to have a basic knowledge of color principles before studying the methods of color reproduction. This is true for the same reason that it is desirable to have an understanding of the nature of radio waves before considering the methods of transmitting and receiving them. For a similar reason, a knowledge of the nature of sound waves and the means by which they are received by the ear is very helpful in the understanding of audio systems. Convinced of the soundness of this reasoning, we are beginning this training series with a discussion of color principles before we discuss the technical aspects of the color television system.

The science and practice of determining and specifying colors is referred to as colorimetry. The development of the present color television system was greatly aided by applying the principles of colorimetry. Since the system had to be designed to reproduce things as they are seen in nature, the characteristics of light, vision, and color had to be taken into consideration. Therefore, the science of colorimetry has been of great importance to the color television engineers who contributed to the design of the system.

Colorimetry is a very complex subject. It is not necessary to be an expert colorimetrist in order to understand the make-up of the color picture signal and the way in which it is utilized in the color receiver; however, a better understanding of the color television system will be attained if some of the most important fundamentals of colorimetry are known. The principles of color as applied to color television are slightly different than those which many of us have been taught in connection with other types of color reproduction.

The properties of light and vision should be understood before studying the principles of color. Light is the basis of color, and the eye must be able to convey picture sensation to the brain.

### Vision

The study of light and color embraces the study of vision. The way in which the eye sees light and the limits of vision should be known before the characteristics of light and color are considered.

Human vision is a dual process occurring partly in the eye and partly in the brain. The light output from an object stimulates the eye. This stimulation is transferred to the brain where it is registered as a conscious sensation.

The structure of the eye is similar in many respects to a mechanical instrument. The eye consists essentially of a lens system, a variable diaphragm, and a screen. The variable diaphragm is the iris of the eye, and the screen is the retina. The structure of the eye is shown in Fig. 1-1. Light enters the eye through a transparent layer called the cornea. The amount of light which is allowed to strike the lens is controlled by the contraction and expansion of the iris. During a low light level the iris expands, and during a high light level it contracts.

The light passes through the pupil, which is the aperture of the iris, and then through the lens, which is directly behind the iris. There the light is broken up and is focused to form an image on the back wall or retina of the eye. The light on the retina stimulates nerve terminals which are called rods and cones. These rods and cones are connected to the brain by a group of nerve fibers called the optic nerve which furnishes the path by which the light impulses are transferred from the eye to the brain.

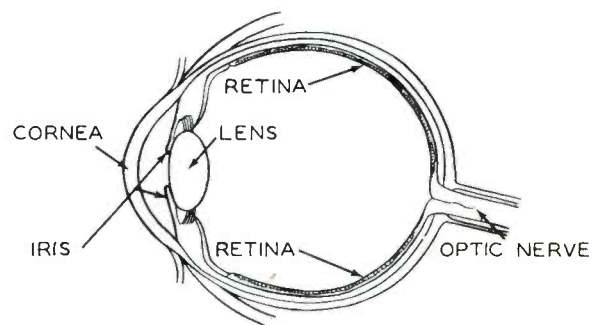

Fig. 1-1. Structure of the Human Eye.

The field of vision covers a wide angle of about 200 degrees horizontally and 120 degrees vertically. In the central region of the field of vision the eye is responsive to color and detail, whereas in the outer region it is chiefly sensitive to motion.

The limits of vision are chiefly determined by four factors: intensity threshold, contrast, visual angle, and time threshold. Intensity threshold is the lowest brightness level that can stimulate the eye and is very much dependent upon the recent exposure of the eye to light. When a person enters a darkened room, it takes the eye a long time to reach its maximum sensitivity. The required time, which is usually about an hour, differs among individuals. When a person returns to a lighted area, the time it takes for the eye to reach its maximum sensitivity is very short, just a matter of minutes.

Contrast represents a difference in the degree of brightness. The limit of vision with respect to contrast is the least brightness difference that can be perceived. The eye is sensitive to percentage changes rather than to absolute changes in intensity.

As an object is made smaller or is placed at a greater distance from the eye, the angle formed by the light rays from the extremities of the object to the eye becomes smaller. This angle is referred to as the visual angle. In order for the eye to respond, the visual angle must be such that the image covers a definite area on the retina. If this area were decreased in size, a point at which the eye could no longer see the object would be reached. This principle is used in eye tests in which the viewer is asked to read the smallest letters possible. Those letters which he cannot read produce on the retina an image that is too small to be useful to the eye. The minimum visual angle is dependent upon the contrast and



**ou cannot pick television  
replacement controls from a tree!**

*use...*

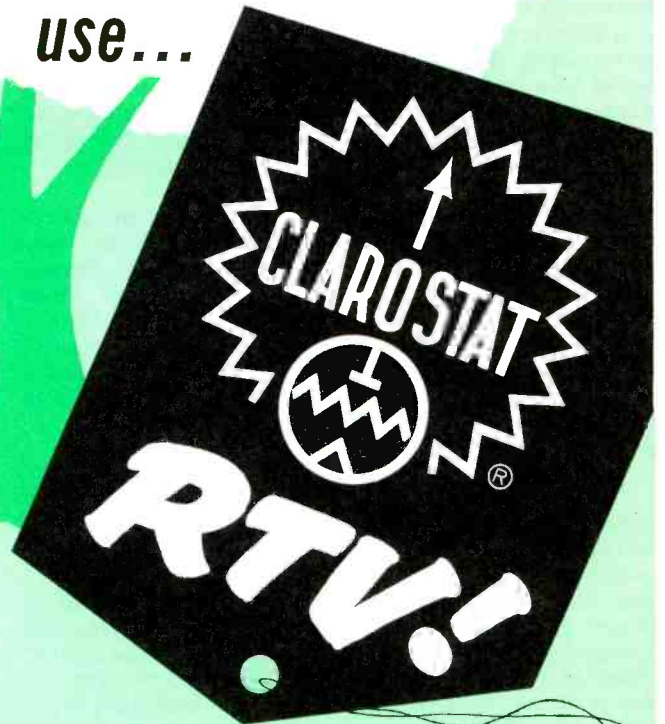

It's easy to pick *the right* television replacement control from the Clarostat RTV program. Clarostat offers you the most complete line of television replacement controls and complete technical data to aid you in selecting the right one.

***Get the complete story on the RTV PROGRAM  
from your Clarostat Distributor today!***

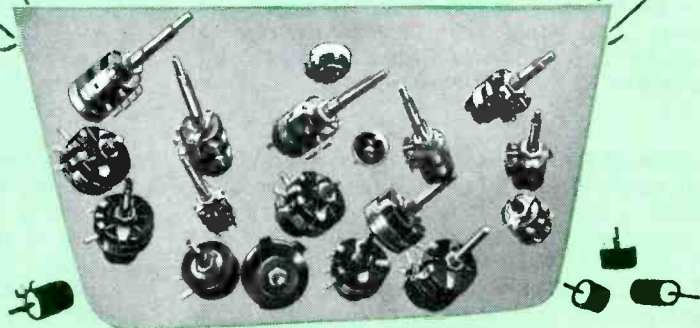

**CLAROSTAT MFG. CO., INC., DOVER, NEW HAMPSHIRE**  
In Canada: Canadian Marconi, Co., Ltd., Toronto 17, Ont.

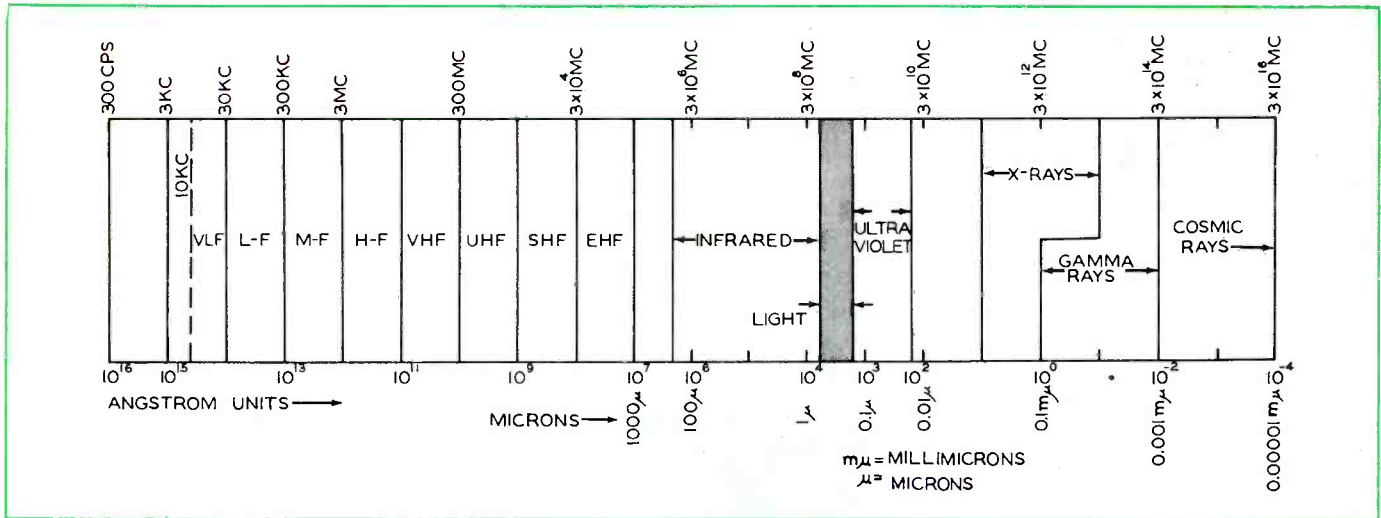

Fig. 1-2. Radiant-Energy Spectrum.

brightness of the image; for example, an object having sharp contrast could be distinguished at a narrow visual angle while the same size object having a lower contrast might not be visible. The same thing applies to a change in brightness in that a very small object can be more easily seen at a high brightness level than at a low brightness level.

There is a minimum time during which a stimulus must act in order to be effective. This is called the time threshold. If the exposure interval is too short, the rods and cones do not have time to respond to an image on the retina. The time threshold is also dependent upon the size, brightness, and color of the object.

Other factors which pertain to the characteristics of vision are:

1. Sensitivity to detail is increased by high contrast, sharp edges, and motion.
2. Straight lines are more readily resolved than curved lines. Horizontal or vertical lines are more easily resolved than diagonal lines.
3. Altering the background of an object changes the appearance of the object. A gray object appears lighter when it is placed upon a black background. On the other hand, it appears darker when placed on a white background.

### Light Sources

The foregoing has shown how the eye is capable of seeing. Let us now discuss the light sources which we must have in order that the eye may be able to use its seeing facilities. In order to see we must have a source of light, just as in the process of hearing, we must have a source of sound before we are able to hear. Obviously, if sound waves were not present, nothing would be heard. So, if a source of light were not present, nothing would be seen.

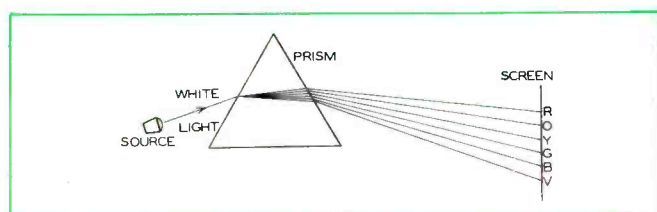

Fig. 1-3. Dispersing Light With a Prism.

When we speak of light, we usually think of light coming from the sun or the light which is emitted from some artificial lighting source such as electrical lighting. This type of light is referred to as direct light. Another type of light is indirect or reflected light which is given off by an object when direct light strikes it. The difference between these two types of light is that the indirect light is dependent upon the direct light. When light is not shining upon an object, light will not be given off unless the object contains self-luminating properties.

Direct light falling upon an object is either absorbed or reflected. If all of the light is reflected, the object appears white. If the direct light is entirely absorbed, the object appears black. The larger the amount of light that is reflected by an object, the brighter the object will appear to the eye. In addition, the more intense the direct light source, the brighter the object will become. This can be demonstrated by casting a shadow upon a portion of an object and noting the difference in brightness of the two areas. The portion without a shadow will, of course, appear brighter.

Light is one of the many forms of radiant energy. Any energy that travels by wave motion is considered radiant energy. Classified in this group along with light are sound waves, X-rays, and radio waves.

As shown in Fig. 1-2, light which is useful to the eye occupies only a small portion of the radiant-energy spectrum. Sound is located at the lower end of the spectrum, whereas cosmic rays are at the upper end. Light falls just beyond the middle of the spectrum. Along the top of the spectrum illustrated in Fig. 1-2 is the frequency scale, and along the bottom is the Angstrom-unit scale ( $10^{-8}$  cm). Wavelengths in the region of light may be designated in microns (1 micron =  $10^{-4}$  cm). These units are also shown along the bottom of the spectrum in the illustration. Light is made up of that portion of the spectrum between 400 and 700 millimicrons.

When all wavelengths of the light spectrum from 400 to 700 millimicrons are presented to the eye in nearly equal proportions, white light is seen. This white light is made up of various wavelengths which are representative of different colors. This composition can be shown by passing light through a prism, as shown in Fig. 1-3. The light spectrum is broken up into its constituent wavelengths, with each representing a different color. The ability to disperse the light by a prism stems from the fact that light of shorter wavelengths travels slower

\* \* Please turn to page 39 \* \*



**WILLIAM SCHOOLEY, owner**  
SCHOOLEY TELEVISION SALES & SERVICE  
3019 W. 111th Street  
Chicago, Illinois

# "Here's proof the CQS Plan can really help your business"

"SEE HOW IT WORKS FOR ME . . ."



"CBS-Hytron is running advertisements like these in LIFE. Maybe you've seen them and noticed they really do a selling job for us service-dealers. Well, I'm one service-dealer who is cashing in on a plan that's tailor-made for me."



"So, I'm using the CQSTags on every job. Many of my customers now ask for them. They like the Tag's lay-it-on-the-line certification. Since December, I've ordered three lots of Tags . . . 500, 1000 and 2000."

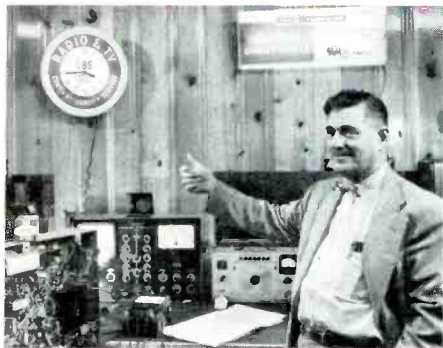

"I like my customers to know I'm the dependable CQS service-dealer they read about in the big magazines like LIFE and the POST. So I make sure they do . . . by using the CQS Clocks, Signs, Decals, etc., available to any service-dealer."



"Take my word for it. Here's a plan that's so simple . . . so sound that any service-dealer is missing a real bet, if he doesn't tie in . . . and cash in. The boost that CQS has given my business proves it."



"Look at the 'sell' of these new CQS Streamers! Get aboard this CQS plan. It can do just as fine a job for you as it is doing for me. Take a tip. Find out today the facts about CQS. Prove to yourself that CQS can build up your business, too."

**GET YOUR Certified QUALITY SERVICE TAGS** . . . imprinted with your name and address. Use them on every job. Get your big, new CQS CBS-Star Kit. It contains:

- A.** Six smashing, colorful CBS-Star streamers. Each features a different CBS-TV star: Benny . . . Burns and Allen . . . Gleason . . . Godfrey . . . Murrow . . . and Marie Wilson. Each streamer is a different size and shape. Each one sells the Star Performance of your Certified Quality Service.
  - B.** New colorful inside/outside CQS decal.
  - C.** Business Builders Catalog showing the many hard-hitting sales aids available to you.
- CBS-STAR KIT IS FREE** with your order for CQS Tags . . . Kit alone, 25¢.

*Ask your distributor salesman for special offer.*

## HOW TO GET:

- . . . Your CQS Tags
- . . . Your CBS-STAR Kit

See your CBS-Hytron distributor today. He has a special offer for you. Or order direct from CBS-Hytron, Danvers, Mass.

Either . . . CBS-Star Kit free with CQS Tags @ \$2.25, 250; \$3.50, 500; \$6.00, 1000

Or . . . CBS-Star Kit *only* @ 25¢, for handling and mailing

Be sure to include your 3-line imprint (print legibly, please) for CQS Tags. Send cash, check, money order . . . no C.O.D.'s.



Manufacturers of Receiving Tubes Since 1921

**CBS-HYTRON** Main Office: Danvers, Mass.

A Division of Columbia Broadcasting System, Inc.

A member of the CBS family: CBS Radio • CBS Television  
Columbia Records, Inc. • CBS Laboratories • CBS-Columbia • and CBS-Hytron

# Notes On

# TEST EQUIPMENT

## Presenting Information on Application, Maintenance, and Adaptability of Service Instruments

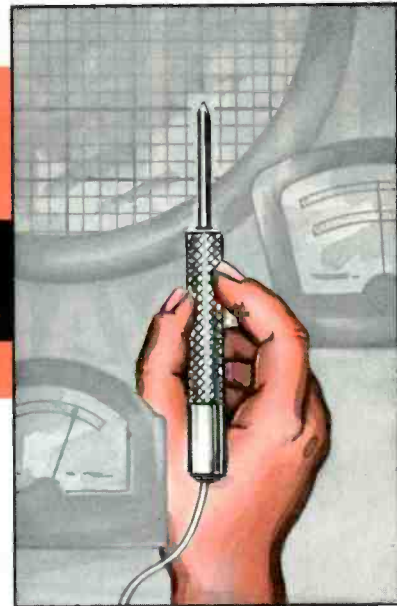

by Paul C. Smith

### Convergence Adjustments with the Hickok 650C Videometer

Certain adjustments in setting up a color TV receiver for proper operation are made easier through the use of a white-dot signal such as that provided by the new Hickok 650C videometer. The adjustments we refer to are the static and dynamic convergence adjustments.

Before making these convergence adjustments, any preliminary adjustments such as high voltage, color purity, and focus should have been made. The manufacturer's instructions should be followed as closely as possible with respect to the order and manner of all adjusting.

The structure of the color tube using the three-gun, shadow-mask principle (the color tube considered in this article) has been the subject of recent articles in this and other publications, so no detailed explanation of this structure will be offered here. For proper operation of the color tube, the three electron beams (one for each gun) must be made to pass through holes in the shadow mask at a precise angle. When controlled in this manner, the three

beams strike three adjacent dots on the tube face — a red, a green, and a blue phosphor. If the beam intensities of the three guns are of the proper proportions, the resultant red, green, and blue lights are blended in the eye of the observer and a sensation of white light is experienced.

In order to effect this convergence, several controls or adjustments are provided. The nomenclature applied to these adjustments may vary slightly with different manufacturers; but for the receiver under consideration, they are as follows:

DC convergence.

Beam-positioning magnets.

Vertical-dynamic-convergence amplitude.

Vertical-dynamic-convergence phase.

Horizontal-dynamic-convergence amplitude.

Horizontal-dynamic-convergence phase.

The first requirement for convergence adjustment is a steady signal source for producing white dots. The Hickok 650C videometer is such a source. When it is properly applied to a normal black-and-white TV receiver, a pattern of regularly spaced white dots is obtained. The same white-dot pattern on a color TV receiver indicates proper convergence adjustment.

The 650C videometer should be connected to the antenna input

terminals of the color receiver, preferably through a matching pad such as the Hickok Type 75. If the Type 75 pad is not at hand, the termination network diagrammed in Fig. 1 may be used. The receiver and videometer should be set to any channel not received locally and the receiver tuned for best dot definition.

Adjustment of the DC convergence control varies the voltage applied to the No. 4 or convergence grid of the color tube. This affects the positioning of the three beams in the manner indicated in Fig. 2. In this diagram, the dotted arrows indicate movement obtained through adjustment of the DC convergence control; the solid lines indicate movement obtained through adjust-

\* \* Please turn to page 72 \* \*

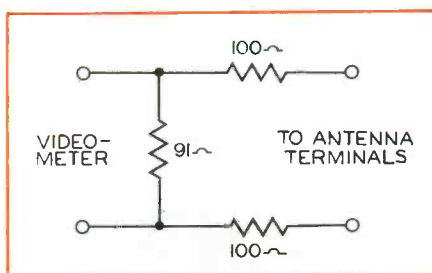

Fig. 1. A 300-Ohm Terminating Network.

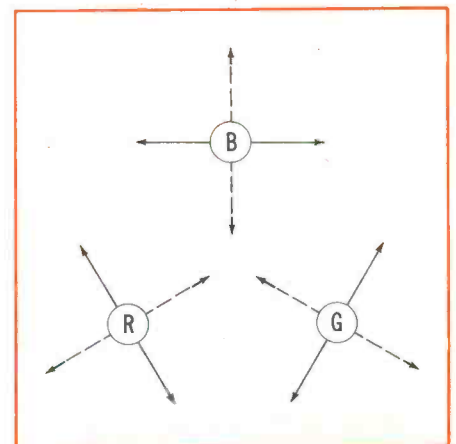

Fig. 2. Movement of Dots During Adjustment of the Beam-Positioning Magnets and the DC Convergence Control.

# WARD

## TELE-VANES

*a sale on sight!*

...AND **WARD'S** PEAK PERFORMANCE GIVES YOU THE "LION'S SHARE" OF THE REPLACEMENT MARKET!

The replacement market for TV antennas is BIG... and for Ward Dealers it's EXTRA BIG! Yes, thanks to the smartly styled new Tele-vane TV antennas, Ward dealers are replacing, not only worn-out antennas, BUT OLD STYLE, CUMBERSOME antennas, even though still serviceable. Ward Tele-vane TV antennas SELL ON SIGHT because they ADD BEAUTY to the home! And Ward's precision engineering and top-quality construction assure complete satisfaction.

### MORE PROFIT-DOLLARS PER SALE!

Extra profits...extra DOLLARS in YOUR cash register...are YOURS when you sell Ward Tele-vanes.

### WARD HELPS YOU SELL!

A power-packed promotion...ads in national magazines, coupled with well planned, effective dealer aids make these beauties the easiest of all to sell. Write for complete information.



**Ward Dymon-vane Conical** is designed for effective reception on VHF Channels 2 through 13 in areas where relatively strong signal strength is available. Pre-assembled for easy installation.



**Ward Circle-vane Yagi** is a ten element double driven VHF antenna designed for use on channels 2 through 6 in areas where gain and directivity pattern are important. Ideal for difficult fringe area installation.

WARD

## PRODUCTS CORP.

DIVISION OF THE GABRIEL COMPANY  
1148 Euclid Ave., Cleveland 15, Ohio  
Canadian Distributor: ATLAS RADIO CO., LTD., TORONTO, CANADA





# HORIZONTAL

## AFC

## Circuits

### Part II

### Operation of The Pulse-Width System

by William E. Burke

The previous issue of the PF INDEX contained the first in a series of articles designed to cover the various methods of automatic frequency control of the horizontal sweep oscillator in television receivers. To continue this series, we shall now cover the second most commonly used system, namely, the synchroguide or pulse-width control system. A typical circuit is illustrated in the schematic of Fig. 8-8. Waveform numbers on the schematic identify points at which significant waveforms can be observed. The operation of the system may be explained through an analysis of these waveforms and the phase relationships between them.

The connection of the equipment for this analysis was given in the previous installment, but it will be repeated here for the convenience of the reader. In order to provide a suitable means of comparison between the various waveforms, the oscilloscope was synchronized externally with the saw-tooth voltage which is

present at the grid of the horizontal-output tube. A 500,000-ohm resistor was included in series with this external sync connection so that receiver operation would not be disrupted by loading of the circuit. By synchronizing the scope in this manner and by maintaining the frequency and amplitude of the horizontal sweep of the scope at constant values, we have shown all the waveforms with reference to approximately the same time base. Then, by placing associated waveforms one above the other, any change in either the frequency or the phase of these waveforms is made apparent. In addition, an isolation probe was used to prevent the input capacitance of the scope from affecting the receiver performance. There is a note of warning for the reader desirous of following the analysis by direct observation of the waveforms. The waveform W8 which is pictured, originates at the plate of the damper tube and may have an amplitude of 1,000 volts or more. This will damage the oscilloscope unless a capacitive type of voltage

divider is used to reduce the voltage to a safe value.

The normal operation of any television receiver presupposes that the horizontal oscillator is operating properly; hence, its operation will be considered first. Normal operation of the oscillator in turn implies that some means of frequency control must be in effect; thus, the AFC tube is secondary to the oscillator. Furthermore, the AFC tube requires a directing signal for its action, and the sync pulse provides this direction. The foregoing provides the basis for the order of explanation for the various functions.

#### Oscillator.

The horizontal oscillator, represented as V2 on the schematic of Fig. 8-8, is a modified form of blocking oscillator. It also incorporates the discharge function without the use of a separate discharge stage.

The operation cycle can be described by beginning at the instant when plate voltage is first applied. Since the grid voltage must begin at zero, plate current will flow in the tube. This current will also flow through L1; and, by virtue of the changing magnetic field, a voltage will be induced into L2. Coil L2 is connected so that the induced voltage is positive on the grid when the plate current is increasing. The positive grid voltage will rapidly drive the plate current higher which will, in turn, drive the grid voltage more positive. This action continues until a point near saturation is reached, at which time the rate of plate-current increase is lessened. This in turn reduces the induced voltage on the grid which further slows the increase of plate current. This action is cumulative and ends with the plate

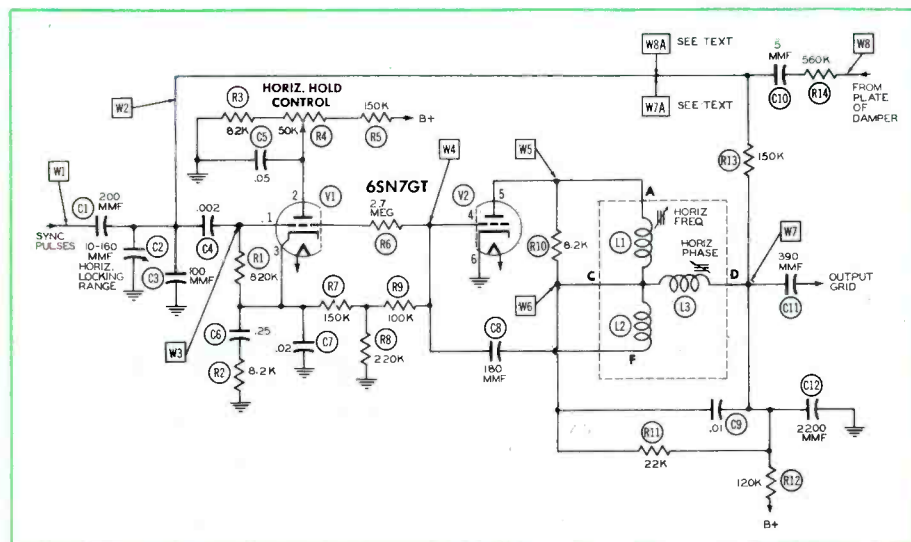

Fig. 8-8. Schematic of Synchroguide AFC System.

\* \* Please turn to page 47 \* \*

WHEN THE



**BONDED  
ELECTRONIC TECHNICIAN  
PROGRAM  
REMOVES  
THIS  
CHIP...**



*You're in the chips!*



Customer confidence in you and your way of doing business is the greatest single business asset you can have. The *RAYTHEON Bonded ELECTRONIC TECHNICIAN* program, now in its 10th year, has helped and continues to help many thousands of Radio and Television service dealers break down the barrier of public mistrust. And in so doing increases the volume and profit of these Raytheon Bonded Technicians.

Ask your Raytheon Tube Distributor if you can qualify for this priceless sales asset. If you can, the program costs you not one cent, it's Raytheon's investment in *your* future.



**RAYTHEON MANUFACTURING COMPANY**

Receiving Tube Division

Newton, Mass., Chicago, Ill., Atlanta, Ga., Los Angeles, Cal.

*Excellence in Electronics*

RAYTHEON MAKES ALL THESE: RECEIVING AND PICTURE TUBES • RELIABLE SUBMINIATURE AND MINIATURE TUBES • SEMICONDUCTOR DIODES AND TRANSISTORS • NUCLEONIC TUBES • MICROWAVE TUBES

# TV COLORMATH



PART II

by HAROLD E. ENNES

## Composite Color Signal Modulation Levels

Before continuing with our discussion of TV Colormath, let us review briefly the conventional monochrome transmission levels. See Fig. 7.

The video-volts scale on the studio monitors is shown at the left in Fig. 7A. Note that the one-volt video includes the 10 per cent setup level between reference black (maximum picture black) and the blanking level. To the right is shown the corresponding depth of modulation of the video carrier. Reference white (maximum picture white) at the studio corresponds to 12.5 per cent  $\pm$  2.5 per cent of the maximum carrier. Thus, a minimum carrier is established so that cutoff of the carrier does not occur. Very few transmitters are linear below the 12.5 per cent point, and operation below this point would result in brightness distortion. Most important, carrier cutoff results in severe audio buzz in some intercarrier receivers because of the momentary loss of the 4.5-mc beat upon which the intercarrier action depends. This may be termed the "white setup level." When we speak of setup level at the trans-

mitter, we normally refer to the difference between reference black and the blanking level, since this ratio is consistent for all scenes whereas amplitude of white varies between scenes. For good brightness reproduction at the receiver picture tube (Fig. 7B), the cutoff bias may be adjusted by means of the brightness control to reference-black level. So long as the proper setup is observed at the transmitter, background brightness in the receiver will remain consistent with the transmitted scene. Constant setup level also minimizes brightness variations in receivers not using DC restorer circuits.

Fig. 7C shows the modulation levels of the composite color signal. Since only modulation levels are being considered at this time, no attempt has been made to show phase angles of the color carrier. The color luminance levels for the luminance carrier are shown in solid lines at steps corresponding to the individual brightness levels of the color bars. The values shown are for color bars of maximum

saturation. The dotted arrows show the maximum excursion of the color-carrier level for each of the colors indicated. The amplitude of the carrier would be lower for desaturated colors of the same hue.

Note that at maximum brightness levels, the carriers representative of highly saturated blues and reds extend into the sync region and that the carrier for highly saturated yellows extends below carrier cutoff. This situation results in a certain amount of clipping of signals from color bars; however, such high saturation is seldom met when televising actual scenes.

Note an important difference in the video-volts scale from that in Fig. 7A. For this example we have chosen an operating practice where one-volt video or reference white results in 15 per cent modulation of the carrier. This varies in practice from 10 to 15 per cent. The setup level shown is 10 per cent and may vary in practice from 5 to 10 per cent. The resulting luminance levels and the amount of clipping for saturated blues, reds, and yellows depend upon which operating practice is followed. A difference in operation may be noticed on a receiver when it is being switched between two stations which follow opposite extremes of the aforementioned ranges, if the controls are left fixed.

The video-volts scale (Fig. 7C) is arranged to start at reference black rather than at the blanking level, as in Fig. 7A. If this were not so, then blue, which contributes only 0.11 luminance volt, would be swallowed up in picture black. As it is, blue reproduces on a monochrome receiver a shade of gray only perceptibly lighter than black. Red reproduces lighter gray, green still lighter, and

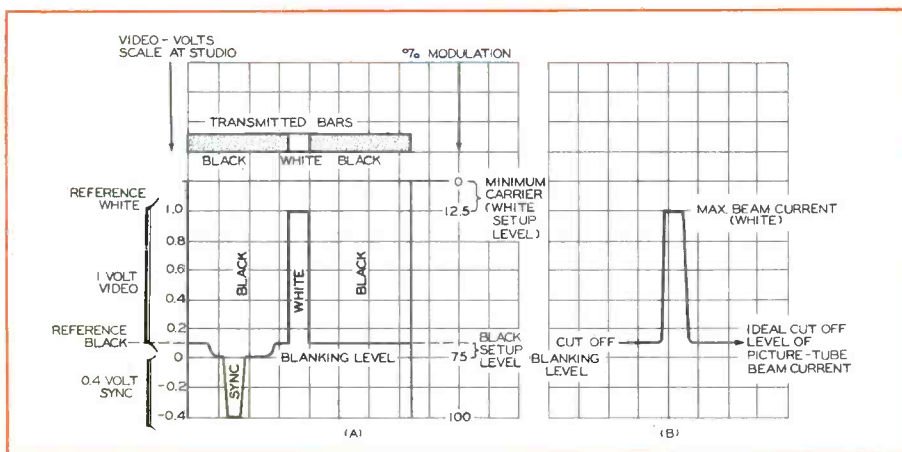
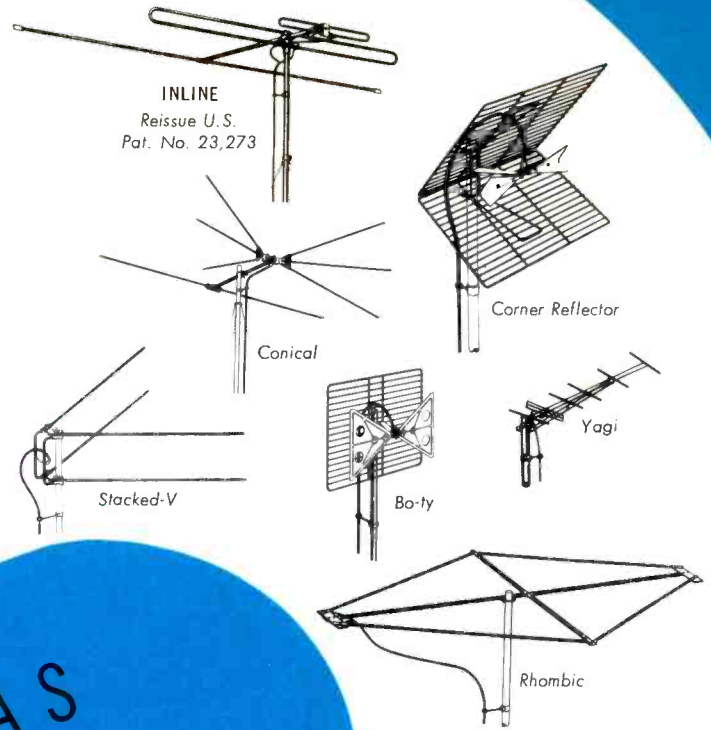

Fig. 7. Levels of Modulation and Picture-Tube Beam Current for Monochrome Signal. (A) Video Volts and Corresponding Depth of Modulation for a Monochrome Signal. (B) Corresponding Picture-Tube Beam Current.

AMPHENOL installation-proved VHF and UHF television antennas are the first choice of dealers, servicemen and distributors because they are easy to sell. Viewers choose AMPHENOL antennas for the very good reason of better picture quality, their assurance of viewing satisfaction.



TV ANTENNAS



& TV ACCESSORIES



Flat Twin-Lead



AIR-CORE  
Tubular Twin-Lead  
(U.S. Pat. No. 2,543,696)

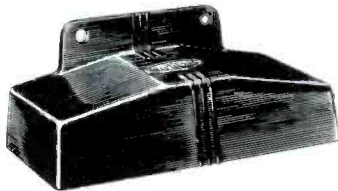

New AMPHENOL Trisonet, Isonet and Tele-Couplers utilize the same attractive case design.

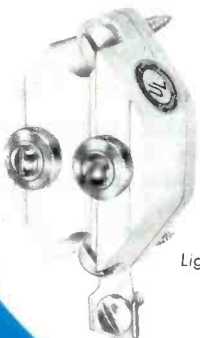

Lightning Arrestor

AMPHENOL television accessories are designed by skilled engineers with years of experience in electronics. Each installation accessory, whether it is the new Lightning Arrestor, new Tele-Couplers, or any other part, operates at peak efficiency because of AMPHENOL quality-designing.

AMERICAN PHENOLIC CORPORATION



## Chrominance Modulation

Sync and blanking pulses are generated in the conventional sync generator at the studios. The difference from conventional monochrome transmission lies in the practice of driving the sync generator from circuits which count down from the color-subcarrier generator. This locks the chrominance- and luminance-control pulses into an integral relationship.

Fig. 8A illustrates this procedure in block form. The output of the sync generator supplies all terminal driving pulses and composite transmitted pulses as in conventional practice. In addition, the H and V pulses drive a color-sync-burst gate which keys the color sync burst ON for a short duration during the time of the H back porch, and OFF for 9H\* during the vertical interval. Note that the color-sync-burst amplifier is fed directly from the subcarrier oscillator. The color burst is also gated OFF during monochrome transmission.

The subcarrier oscillator also feeds the phasing circuits to derive the I and Q driving signals. The net result is that the color sync burst leads the I and Q channels which are in quadrature. This allows the synchronous demodulator in the receiver to use the sync burst as a reference from which to decode separately the information in the I and Q channels.

We are now in a position to see the formation of the actual transmission primaries. The B - Y and R - Y signals were modified in amplitude in the I-Q matrixer as:

$$I = -0.27 (B - Y) + 0.74 (R - Y) \quad (6)$$

$$Q = 0.41 (B - Y) + 0.48 (R - Y) \quad (7)$$

Each contains both R - Y and B - Y.

From Fig. 8A, we see that the I and Q signals will be 90 degrees apart because the drive frequencies of the I and Q subcarrier are phased in quadrature. The I components lead the Q components by 90 degrees. Let us see what happens to the color-difference signals which form the I and Q channels. First, let us consider the R - Y component.

Observe section 1 of Fig. 8B. The I channel, which contains 0.74 of R - Y, leads the Q channel, which has 0.48 of R - Y, by 90 degrees. (See

\* \* Please turn to page 53 \* \*

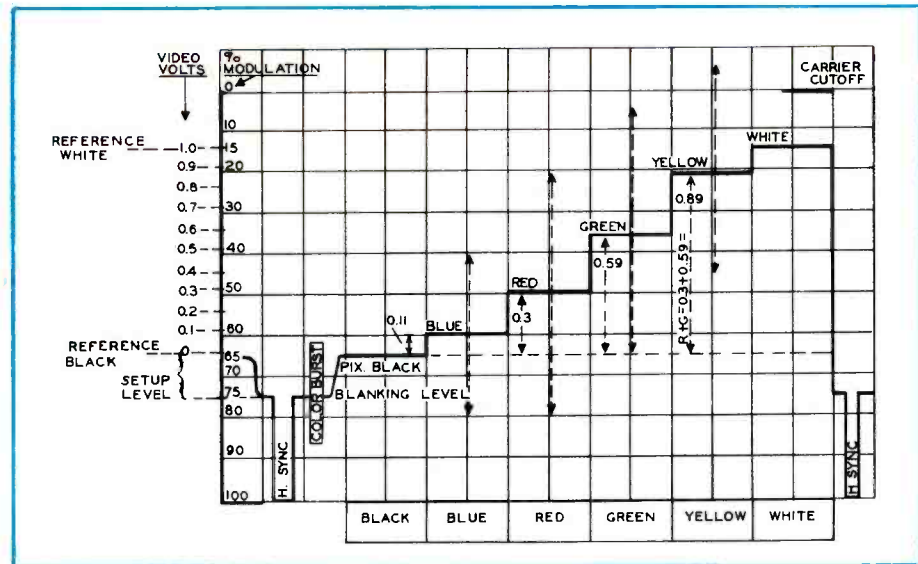

Fig. 7C. Composite Color Signal ( $E_M$ ) Levels.

yellow at maximum brightness reproduces almost white in a monochrome receiver.

It should be realized that the ratio of the color-carrier amplitude to luminance amplitude depends upon the particular color being transmitted. For example, since blue has only 0.11 in Y and 0.89 in B - Y, it will always have a higher ratio of color-carrier amplitude to luminance amplitude than the other primaries.

All primary color channels at the transmitter and in the receiver are DC set. It may be seen that,

since the luminance carrier supplies the respective brightness levels to the color channels, the practice of establishing a DC setting for the luminance level is also highly important in order to avoid either dilution or oversaturation in colors. Therefore, DC restorers are critical and a must for good color receivers.

The R - Y and B - Y signals are automatically transformed into transmission primaries by placing them in quadrature in the I and Q modulators. This simply means that the R - Y signal leads the B - Y signal by 90 electrical degrees.

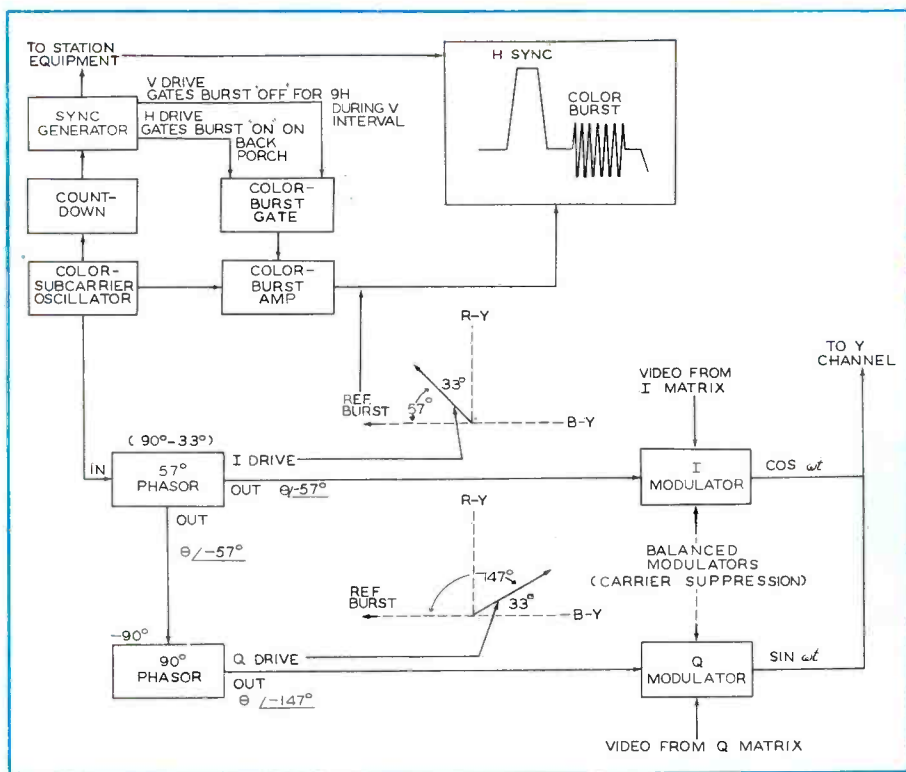

Fig. 8A. Generation of I and Q Drive Signals.

\* H is the duration of one line, or 63.5 microseconds. Therefore, 9H is 9 lines.

# SUPER-PERFORMANCE

...THAT COSTS NO MORE!

## MAKE THE SCREEN TEST!

- 1 Measure the space between reflector elements of any other big screen antenna.
- 2 Note that the TRI-KING has closer spacing between reflector elements for improved performance. The TRI-KING's element spacing is the proven maximum for a full  $1/10$  wave length.

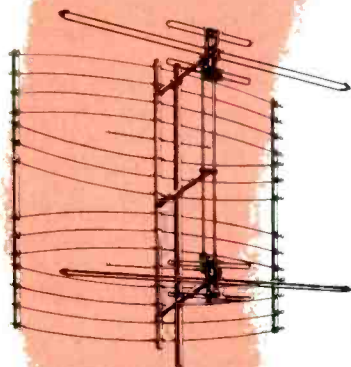

SUPER  
TRI-KING  
Model  
TK1800

**WIND TUNNEL TESTED** to exacting aircraft standards. Test results *prove* that a full size TRI-KING antenna can withstand 30% higher wind velocities than any other large screen antenna.

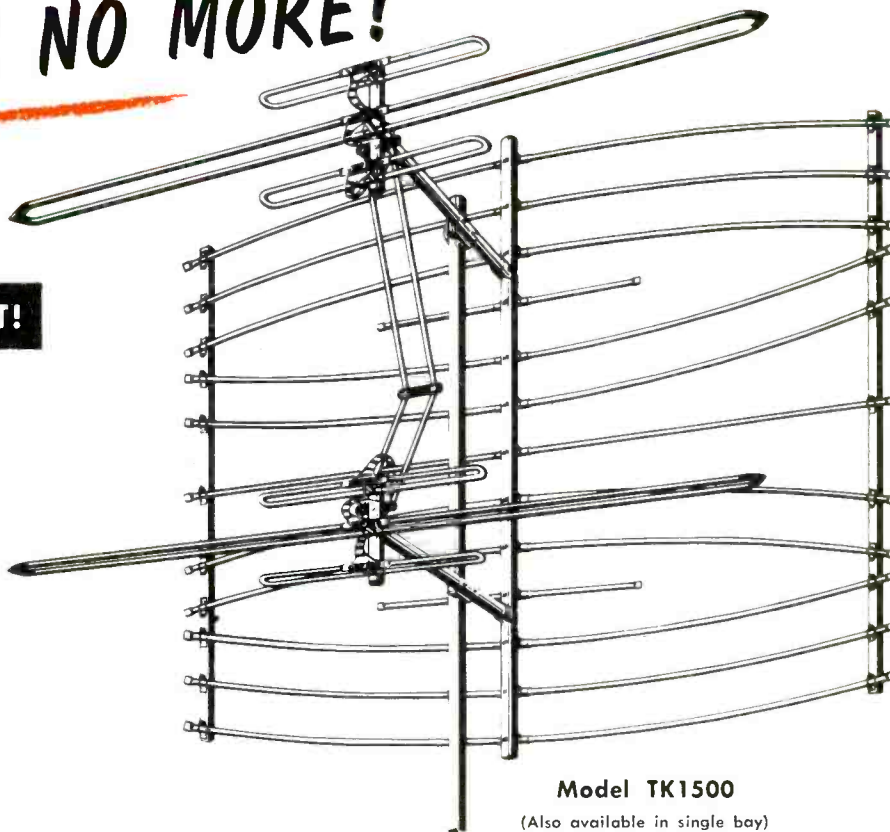

Model TK1500  
(Also available in single bay)

## CLEAR BEAM'S TRI-KING

Patent Applied For

**POSITIVE GHOST REJECTION!** Clear Beam proudly announces the new TRI-KING, combining for the first time a Radar-type reflector screen with the improved TRI-KING dipole assembly. A real champion with many Clear Beam features including rugged, quality construction and Quik-Rig assembly that outsells all other big screen antennas. Sold on a money back guarantee.

WRITE FOR COMPLETE INFORMATION TODAY

**Clear Beam Antenna Corp.**



100 PROSPECT AVENUE • BURBANK, CALIFORNIA  
THornwall 2-4886 • Victoria 9-2141

**ORDER NOW - IMMEDIATE DELIVERY!**

CLEAR BEAM PRICES

Model TRI-KING	List Price
TK1500	\$44.50
Super TK1800	\$52.95

WAREHOUSES IN: San Francisco • Portland • Seattle • Chicago • Kansas City • Detroit • Dallas • Baltimore

# Examining

## DESIGN FEATURES

by DON R. HOWE

### CROSELY MODEL G-17TOMH CHASSIS 426

The Crosley Model G-17TOMH shown in Fig. 1 incorporates several features which depart from the conventional construction employed in most television receivers. The first feature that becomes apparent upon examination of the receiver is its compact size and light weight. It may also be seen from the photograph in Fig. 1 that there are no operating controls present on the front of the cabinet.

If the cabinet is removed from the base assembly, it will be noted that the chassis is mounted vertically. This is readily apparent by referring to Fig. 2 which is a photograph of the cabinet partially removed from the chassis. The normal operating controls which consist of Vertical Hold, Horizontal Hold, Off-On Switch, Volume, Contrast, Station Selector, and Fine Tuning are available on the side of the cabinet. These controls are visible in Fig. 1.

The picture tube is mounted in such a manner that the neck of the tube projects through the chassis. With this arrangement, the deflection yoke is mounted directly on the chassis. The elimination of the bulky brackets which usually support the yoke contributes to an over-all reduction in the weight of the receiver.



Fig. 2. The Crosley Model G-17TOMH With the Cabinet Partially Removed.

The end effect of the physical arrangement used in this receiver is to produce a unit of minimum size and weight for the picture tube employed. Its small size does not constitute the only advantage of this receiver from the standpoint of the servicetechnician. A removable rear panel provides access to the tubes; and because of the vertical placement of the chassis, all tubes are within easy reach. Replacement of the tubes in their respective sockets is facilitated by the fact that the tube sockets are within view. The tube complement

of the VHF version of this receiver consists of 15 tubes, including the picture tube.

When it becomes necessary to perform additional service on the receiver, the cabinet may be lifted from the base assembly to expose the chassis completely. See Fig. 3. This system is also convenient when it is desirable to clean the face of the picture tube.

A word of caution is in order at this point. In this receiver, one side of the AC line is connected to the chassis. This fact should be kept in mind when servicing this set so that shock hazards may be avoided, preferably by the use of an isolation transformer.

### Tuner

A turret type of tuner is used in the Crosley Chassis 426. This tuner provides selection of any one of the 12 VHF channels. The RF amplifier is a 6BC5 pentode providing high gain. The bias on this stage is controlled by the application of AGC voltage to the grid. The output of the RF amplifier is coupled to the grid of one triode section of a 6J6. This section is employed as the mixer; the other section of the 6J6 is the oscillator. The output of the mixer at the IF is coupled to the grid of a 6CB6 IF amplifier.

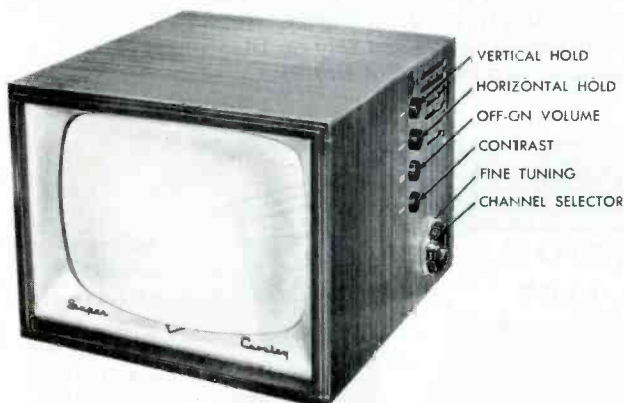

Fig. 1. The Crosley Model G-17TOMH Television Receiver.

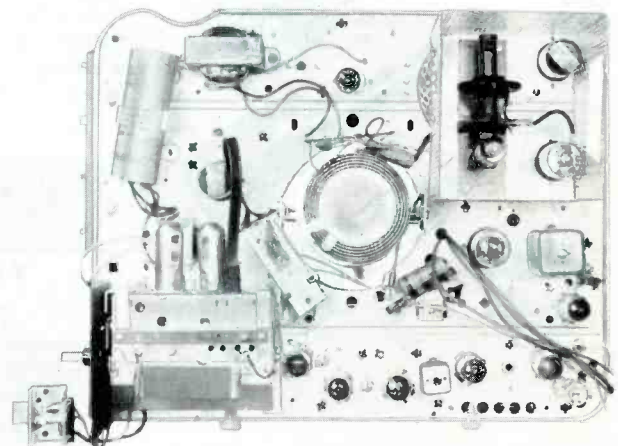

Fig. 3. The Crosley Chassis 426.

*"Trouble-Free"*

# BUSS FUSES

*can help you build*

## CUSTOMER SATISFACTION

Manufacturers and service organizations know from experience that BUSS fuses won't let them down. For over 39 years, under all service conditions, BUSS fuses have given dependable electrical protection.

Rigid quality control is the reason for "trouble-free" BUSS fuses. Every BUSS fuse normally used by the electronic industries is tested in a sensitive electronic device that rejects any fuse not properly constructed, correctly calibrated and right in all physical dimensions.

So for the finest possible electrical protection, turn with confidence to BUSS fuses. The fuse that can be relied on to protect when there is trouble in the circuit. The fuse that eliminates those needless blows, which otherwise could be so annoying to your customer.

And there is another reason it pays to standardize on BUSS fuses. You can simplify your buying, stock handling and records by using BUSS as the one source for fuses. The line is complete — standard type, dual-element (slow blowing), renewable and one-time types . . . in sizes from 1/500 ampere up.

Let BUSS fuses help protect your profits. Why take a chance on a part so small but so important as a fuse? Faulty fuses can cause endless trouble -- if your customer "kicks" there is likely to be a costly, time-wasting "call-back" or replacements. So rely on BUSS fuses . . . that are made to protect — not to blow.

**NEW Complete**

### TELEVISION FUSE LIST

- Shows proper fuse to use
- How fuse is mounted
- What fuse protects

**SEND TODAY FOR YOUR FREE COPY!**



Makers of a complete line of fuses for home, farm, commercial, electronic & industrial use.



UHF is also available in this series of Crosley receivers. Three additional controls are provided for operation of the UHF converter unit. These controls are the UHF channel selector, the fine tuning, and the VHF-UHF function switch. The converter portion consists of a 6T4 oscillator and a 6BK7A IF amplifier. A 1N82 crystal diode is used for mixing.

When the function switch is placed in the UHF position, voltage is applied to the plates of the tubes in the UHF converter. At the same time, the output of the converter is switched to the input of the VHF tuner. The system employs the double-conversion method in which the UHF signal is reduced to a VHF signal and amplified. Then it is reduced to the IF by the second conversion process in the VHF tuner section.

A rather unique method is used for obtaining filament voltage for the tubes in the converter. An auto-transformer placed across the AC line is provided with a tap for the filament line. This circuit is shown schematically in Fig. 4.

Limited coverage of the UHF channels is possible by installing strips in the VHF tuner rather than by using the UHF-tuner subchassis.

### Video IF Stages

The first two stages of IF amplification utilize 6CB6 pentodes. The gain of these two stages is controlled by the AGC voltage applied to their grids. The plate circuit of the second IF stage contains an absorption trap tuned to the sound carrier of 21.9 mc. Transformer coupling is used throughout the IF strip. The pentode section of a 6AM8 serves as the third amplifier with its output transformer coupled to the video detector.

The 6AM8 contains a diode section and a pentode section. Separate cathodes are provided for each section. Since this tube is relatively new, a base diagram is shown in Fig. 5A.

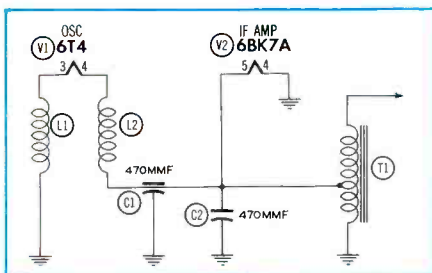

Fig. 4. A Schematic of the Filament String in the Crosley UHF-Converter Subchassis.

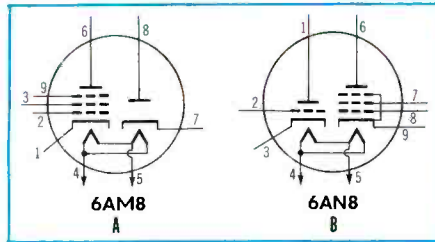

Fig. 5. Base Diagrams of the 6AM8 and the 6AN8.

### Video Detector and Amplifier

The video detector is the familiar diode type utilizing one section of the 6AM8. The signal from the IF strip is applied to the cathode. The plate of this tube is returned to ground through a 5.6K-ohm resistor. The voltage developed across this resistor is used as the AGC voltage. The level of this voltage will therefore be dependent upon the strength of the signal applied to the detector.

Video amplification is accomplished by the pentode section of a relatively new tube, the 6AN8. The 6AN8 contains a medium- $\mu$  triode and a sharp-cutoff pentode. The high transconductance of the pentode section makes it very suitable for application as the video amplifier. The triode section of this tube is used as the sync clipper in this receiver. Each section of the tube has a separate cathode. The base diagram of the 6AN8 appears in Fig. 5B.

The composite video signal in the output of the video-amplifier stage drives the cathode of the 17HP4 picture tube.

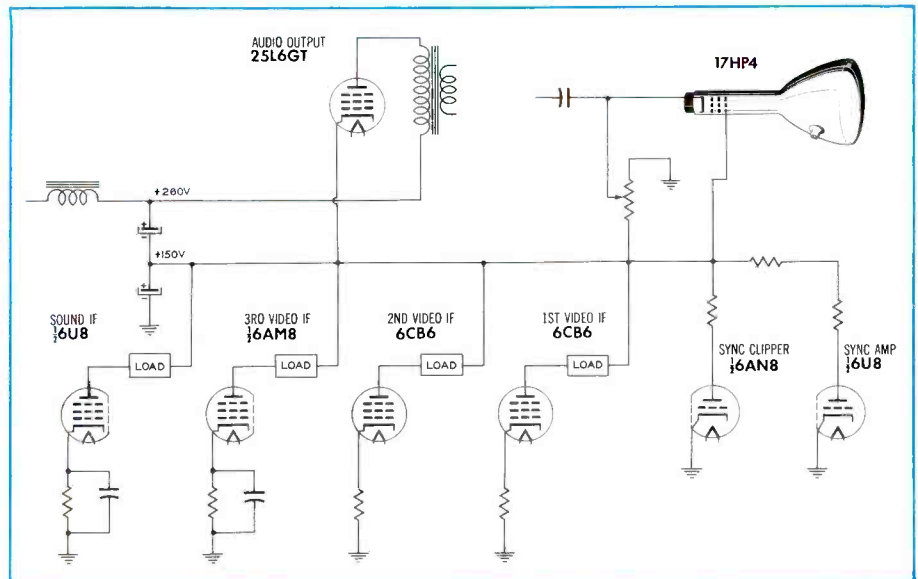

Fig. 6. Simplified Schematic of the Voltage-Distribution System Associated With the Audio-Output Tube in the Crosley Chassis 426.

### Sound System

A transformer in the plate of the video amplifier couples the 4.5-mc sound signal to the sound IF amplifier. The signal is then transformer coupled to a 6BN6 gated-beam discriminator. A buzz control is contained in the cathode circuit of the 6BN6. The resultant audio signal is fed to the output stage which utilizes a 25L6GT.

### Sync System

A composite video signal from the plate circuit of the video amplifier is fed to the grid of the sync clipper. The clipping action is such that only the sync pulses appear in the plate circuit of this stage. The sync pulses are fed to a sync amplifier by means of an RC coupling network. The output of the amplifier feeds sync pulses to the horizontal-sweep section and to the vertical-integrator network.

### Vertical-Sweep System

The pulses from the integrator are fed to the grid of the vertical-blocking oscillator. The vertical-hold control is connected from this grid to ground. The pulse from the blocking oscillator is directly coupled to the grid of the vertical-output tube. This stage contains a height control in the grid circuit and a linearity control in the cathode circuit. The height control is a five-megohm potentiometer with a one-megohm stop. The stop is provided in order to prevent reduction of the resistance to a value below one megohm. The sweep voltage in the plate circuit of the vertical-output tube is applied to the vertical-

\* \* Please turn to page 69 \* \*

"...and all I did was install a  
**WALSCO** antenna"

Buyers are getting wiser. The quality of *their* TV reception is *your* responsibility... and they'll hold you to it! For *your* protection, sell and install

WALSCO, the finest antennas ever built for VHF and UHF.

**WALSCO IMPERIAL CONICAL (all-channel VHF)**

Featuring the new, exclusive "Barrier Disc" Insulator to prevent shorts and maintain lasting high gain performance anywhere. Designed for color as well as black and white. Not affected by dirt, moisture, salt... will not rust. Stainless steel hardware prevents corrosion losses *permanently*. Pre-assembled... guaranteed 3 years!

Single Bay... only \$9.95 List. Also available in Dual and 4 Bay Stacks.

**WALSCO CORNER REFLECTOR (UHF)**

No other UHF antenna so effectively combines all three... (1) extra high gain; (2) all-channel reception; (3) sharp vertical and horizontal directivity. Features the hollow, unbreakable X-77 Insulator... silicone treated to shed dirt and moisture... not affected by extreme heat, cold or wind.

Single Bay... \$10.95 List. Also available in 2 and 4 Bay Stacks.

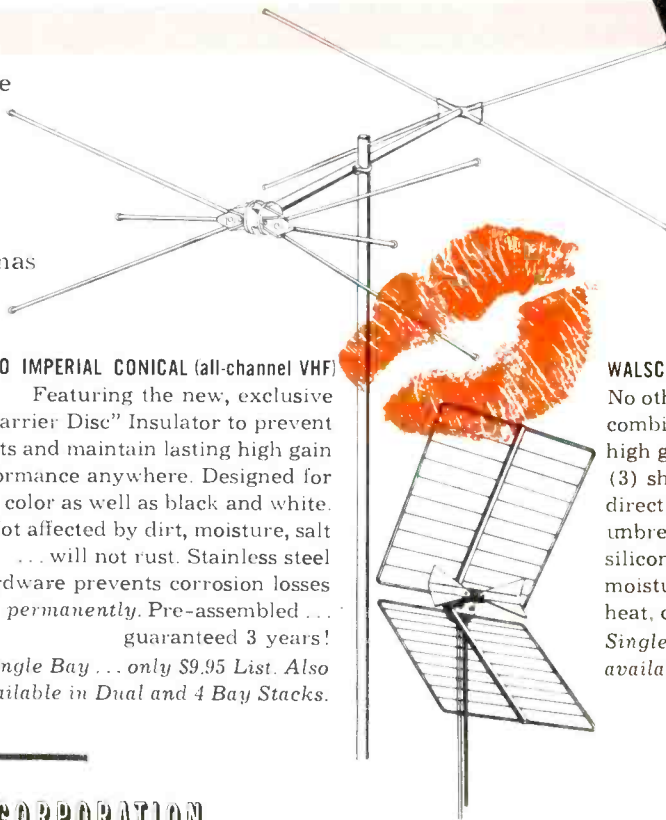

3602 Crenshaw Boulevard, Los Angeles 36, California

Branch: 315 West Walton, Chicago, Illinois

Overseas Distributor: Ad Auriema, Inc., 89 Broad St., New York 4, N.Y.

Canadian Factory Distributor: Atlas Radio Corp., Ltd., 560 King St. West, Toronto 2-B.

# In the Interest of ... Quicker Servicing

by HENRY A. CARTER

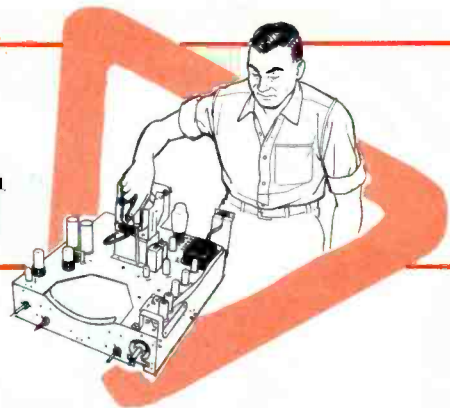

## Video Detectors

As a general rule, troubles originating in the video detector can be traced to that portion of the circuit without too much difficulty. This may be done in various ways, depending upon the symptom.

The symptom most often encountered in the case of video-detector trouble is complete loss of video; and if the set is an intercarrier type, the sound may also be lost. The trouble producing this symptom can quickly be located by employing the scope as a signal tracer. The procedure is to start at the driven element of the picture tube and to work toward the front end of the set until a signal is found. The last stage to show no signal is the one on which to concentrate attention.

When the trouble proves to be originating in the detector stage, it is always a good idea to substitute the diode before checking anything else. If the set employs a diode tube, the chances are that it may already have been checked prior to the signal-tracing operation. However, it will not hurt to try it again. Failures of components other than the diode are rare in the video-detector stage because of the low voltage encountered in this circuit. The only component of the circuit with a large voltage applied to it is usually the coupling capacitor (C2 in Fig. 1) from the plate of the last video IF amplifier.

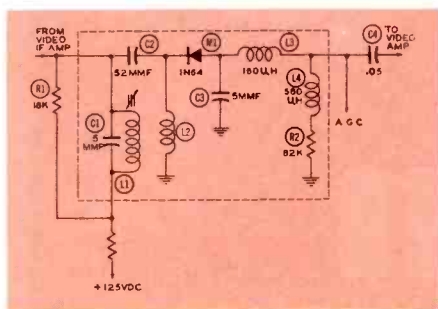

Fig. 1. Typical Video-Detector Circuit Using a Germanium Diode.

At this point, it may be interesting to take a typical video detector and find out what happens to the picture and sound as each component opens up or becomes shorted. The circuit that we will use for these tests employs a germanium diode and may be seen in Fig. 1. The various troubles and their associated symptoms are as follows:

**C1 Shorts.** The picture becomes weak and washed out. This symptom may not be detected on a strong signal, since the contrast control may be set to overcome it. On weak signals, however, improper operation will be obtained on any setting of the contrast control.

**C1 Opens.** Contrast in the picture is slightly reduced. This symptom may not be noticed, since it may be overcome by setting the contrast control.

**L1 Shorts.** The symptoms are the same as those listed for a shorted C1.

**L1 Opens.** The picture is washed out, and the sync is very weak.

**C2 Shorts.** Full plate voltage on the last IF stage is placed across L2, and either or both of the components L1 and L2 may burn out. The picture is very blurred.

**C2 Opens.** The picture contrast is reduced.

**L2 Shorts.** Complete loss of picture and sound results.

**L2 Opens.** The picture goes negative; the sound is unaffected.

**M1 Shorts.** The picture goes negative; no effect is noticeable in the sound.

**M1 Opens.** The video is lost; the sound is unaffected.

**C3 Shorts.** The video is lost; the sound level is reduced.

**C3 Opens.** The picture is faded; no effect is noticeable in the sound.

**L3 Shorts.** The picture loses detail noticeably because of poor high-frequency response; the sound is unaffected.

**L3 Opens.** The picture goes negative; the sound level is reduced.

**L4 Shorts.** The picture loses detail because of poor high-frequency response.

**L4 Opens.** The picture loses detail because of poor high-frequency response.

**R2 Opens.** The only noticeable effect is a reduced high-frequency response.

**C4 Shorts.** The raster goes black.

**C4 Opens.** The picture is lost, and the sound level is reduced.

**M1 Defective.** The picture goes negative; the sound is unaffected.

This series of tests shows one or two significant characteristics of the circuit in Fig. 1. Notice that in many instances of component failure the sound is not lost. In fact, in several cases it is not even seriously affected. The reason for this lies in the fact that the AGC circuit is connected to the video-detector output. The AGC line effectively acts as a

\* \* Please turn to page 63 \* \*

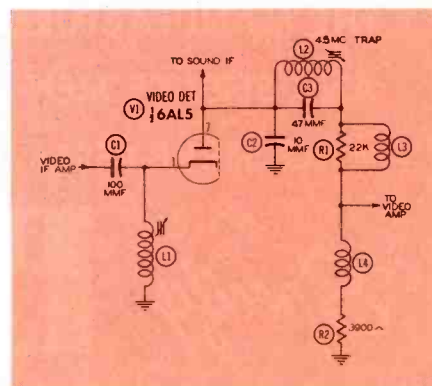
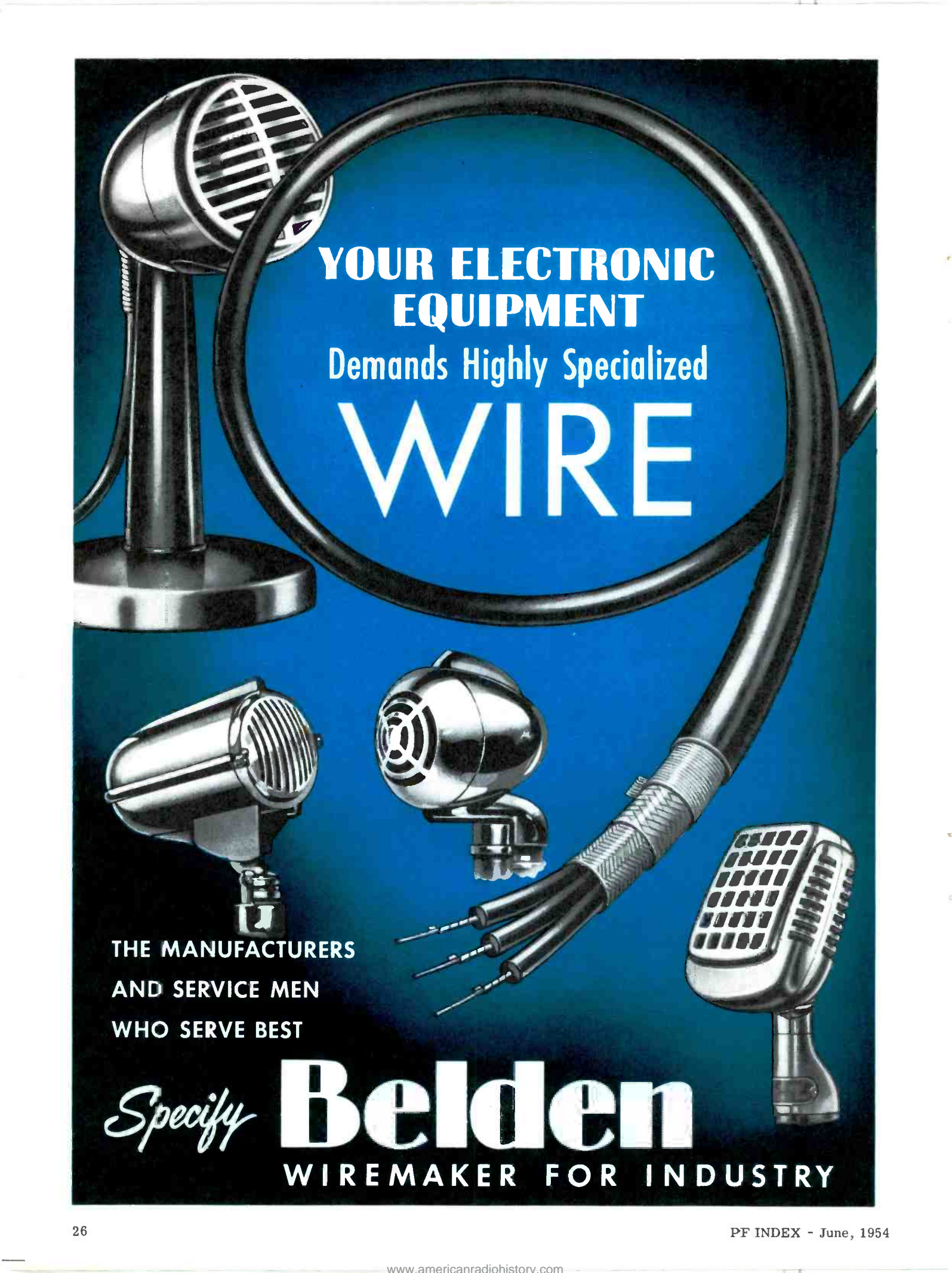

Fig. 2. Typical Video-Detector Circuit Employing a Vacuum Tube.



**YOUR ELECTRONIC  
EQUIPMENT**

**Demands Highly Specialized**

**WIRE**

**THE MANUFACTURERS  
AND SERVICE MEN  
WHO SERVE BEST**

*Specify*

**Belden**

**WIREMAKER FOR INDUSTRY**

# Audio-Facts

## A Small Power Supply Furnishing DC Filament Voltages As Well As Normal DC Plate Voltages

by **Robert B. Dunham**

Most audio enthusiasts, especially those who construct and assemble their equipment, are at some time or other plagued with hum developed in the low-level stages of their sound systems. Consequently, many of them have considered incorporating a DC heater supply in their systems to heat the filaments of the input and preamplifier tubes in order to eliminate the hum introduced by the AC ordinarily used.

Although many have convinced themselves that it would go a long way toward clearing up their hum troubles, they have hesitated to attempt the construction and use of a DC heater supply for several reasons. For one thing, the heating of tube filaments with AC has become such a well-established practice that the use of DC is sometimes thought of as being strange and maybe unorthodox.

Until recently, probably one of the main reasons for not using DC was the difficulty encountered in obtaining the right components with

which to construct the necessary supply. That situation has been changed by the present-day availability of a number of suitable transformers, capacitors, and selenium rectifiers.

The power supply (Figs. 1 and 2) to be described here was constructed on a standard 5-inch by 7-inch by 2-inch chassis and made up of what are commonly termed standard replacement parts. Therefore, it will serve as an example of how easily the problem of obtaining a DC heater supply can be solved.

The original model of this supply was designed and built to replace the power-supply section of the preamplifier-and-control unit described in Audio Facts in the PF INDEX No. 33. It was shown in use with the music system discussed in the Audio Facts column in the March 1954 issue of the PF INDEX. Commercial type capacitors were used in the earlier model, otherwise the circuit is identical to the one shown in Fig. 3.

Power transformer T1 (Stancor PC8417) with a center tapped 440-volt secondary rated at 50 ma, another rated at 25.2 volts at 500 ma, and a third supplying 6.3 volts AC at 600 ma is particularly suitable for this application.

Selenium rectifiers M1 and M2 are connected to the 440-volt secondary to form a full-wave rectifier circuit, as shown in Fig. 3. Full-wave rectification is desirable because the high frequency and low amplitude of the ripple in the rectified output is easy to filter.

The selenium rectifiers M1 and M2 shown in Figs. 1 and 3 are 16Y1 Seletron units each of which is rated at 260 volts AC input and 20 ma DC output. Each 16Y1 rectifier is in effect two 8Y1 units (130 volts AC input, 20 ma DC output) connected in series as a single unit to obtain an effective rating of 260 volts AC input and 20 ma DC output. In order to handle the input of 220 volts AC, two of the 8Y1 units (or two of any listed in the Parts List) can be connected in series and used as M1 with a second pair used as M2.

The output from the rectifier is fed through the 47-ohm surge resistor R1 to the filter composed of resistors R2 and R3 and capacitors C1 and C2. At the power-output socket, 250 volts DC are available when the pre-amplifier-and-control unit is connected and operating at a normal current drain of approximately 9 ma DC.

Two dual 20/20-mfd, 350-volt electrolytic capacitors C1 and C2 were selected for this power supply because of their physical size and availability in addition to their capacity and voltage rating. The two

\* \* Please turn to page 67 \* \*

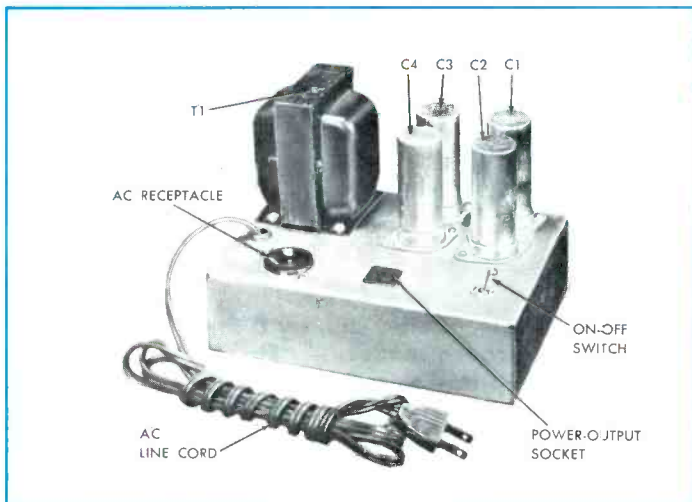

Fig. 1. Top View of Power Supply.

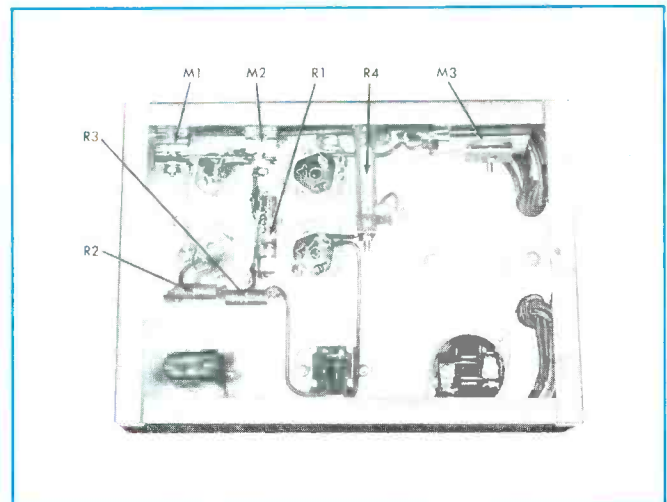
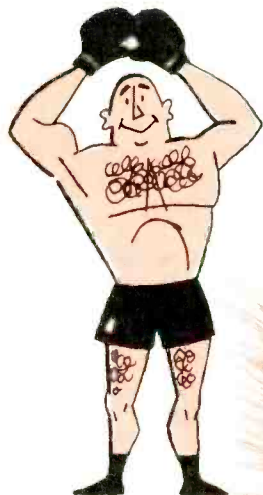

Fig. 2. Bottom View of Power Supply.

Taking On All Comers...

# "CHALLENGER"

# GRANCO'S NEW UHF CONVERTER



Just that! Challenges all other brand converters to any comparative test, anywhere, under similar conditions. Try the "Challenger" for these important points:

## 1 PERFORMANCE!

The finest picture quality and clarity. No other converter in its class offers all these features...

**AMPLIFICATION:** A complete additional stage of amplification for higher gain and perfect reception everywhere.

**COAXIAL TUNING:** No wiping contacts... no noise... highest signal-to-noise ratio... positive oscillator stability.



**PRESELECTION:** An absolute necessity for image and adjacent-channel rejection. The "Challenger" receives and amplifies only the desired signal.

MODEL SLU  
**\$24.95**  
LIST

## 2 OPERATION!

Smoothest and simplest, because:

**FINE TUNING:** High-ratio tuning system with fingertip control makes channel selection speedy and simple.

**EASY-TO-READ DIAL:** New exclusive semi-circular tuning dial with really legible channel designations.

**POWER-SELECTOR SWITCH:** Turns converter and set on and off. Convenience outlet at rear takes TV power cord.

## 3 LOOKS!

Exclusive new modern styling. The most compact converter ever designed. Only 6½" w. x 4½" h. x 4⅛" d. Available in rich mahogany or warm sand-tone plastic.

## 4 PRICE!

Sensibly profit-priced to sell! Only \$24.95 List! (\$27.95 in sand-tone). The greatest value in UHF converters today.

ASK YOUR DISTRIBUTOR...

Let him show you the Granco "Challenger." Better still, try it for yourself. Also see three other new Granco models — "Star," "Super" and "De Luxe" in three higher-priced classes. And don't miss the sensational "Hideaway" series! Literature on request.

*Granco*

**GRANCO PRODUCTS Inc.**

36-17 20th AVENUE, LONG ISLAND CITY 5, N. Y.



# Dollar and Sense Servicing

by | *John Markus*

*Editor-in-Chief, McGraw-Hill Radio Servicing Library*

**PAN-AMERICAN TV.** The possibility of network TV embracing North, South, and Central America along with the Caribbean Islands becomes more a reality with each new station going on the air south of the border. When that comes, television will truly have arrived. The potentialities for the future in South America are terrific, especially for those who speak Spanish. If you ever get the urge to take an adult study course in the evenings, we recommend this language.



**CARTOON.** Hagglund, in the January issue of *Electrical Merchandising*, shows two service technicians sitting glumly in a radio and TV repair shop, clock at 3 p. m., with the caption: "Guess this is one of those days when everything goes right."



**EYE OPENER.** A postwar car was offered free with each purchase of a 21-inch Raytheon TV set at \$550 by Bruno's Appliance and Furniture Center in Chicago. The attention-getting deal, promoted on a TV station as well as in newspapers, caused considerable comment both in and out of the trade. The cars, freshly polished and ready to be driven off the nearby used-car lot, were reportedly valued at around \$300 each. Announcements limited the deal to the first 300 purchases, causing one customer to drive in from the suburbs still in his pajamas, shouting, "Are there any left?" The Better Business Bureau investigated and gave the sale a clean bill of health. To many, it looked to be an ideal marriage of two tough markets — the big TV consoles and the used cars. But one question remained unanswered — were the customers buying TV or used cars?

**CANNED SPEAKERS.** Well under way is used of technical speeches recorded on magnetic tape, along with the appropriate set of slides for gatherings of engineers or service technicians in localities where it is not possible for the actual lecturer to be present. The lecturer delivers his talk once into the microphone of the tape recorder and uses verbal instructions or buzzer signals to call for the next slide, just as if he were delivering the actual speech. Tape and slides are then mailed out to arrive in time for the scheduled meeting.

Already the National Bureau of Standards has recorded a number of engineering lectures on tape. The Institute of Radio Engineers is actively interested in this technique as a means of getting the finest lecturers for its smaller sections and student groups. A file of available taped speeches is being maintained at the Institute's headquarters, 1 East 79th Street, New York City. Groups of service technicians desiring topics of a servicing nature can expedite the introduction of this technique in their field by contacting receiver manufacturers, asking when taped speeches will be available on a particular subject.

Sermons, too, are available on tape for churches without preachers. Copies of the Order of Service are sent with each tape in quantities sufficient to take care of the expected congregation. Instructions for the congregation go on the tape just as they would be given by an actual minister. These recorded tapes are available from the Evangelical Foundation, Inc., 1716 Spruce St., Philadelphia 3, Pa.



**ENGLAND.** Figures in England are now 2.75 million TV sets in use and yearly production of about 800,000 sets, mostly with small screens.

**TAPE RECORDS.** More than a million homes have tape machines, according to an item in *March Electronics*. This figure is in our opinion quite high (*Electrical Merchandising* reports 275,000 sales in 1953 and about 150,000 for 1952, the two biggest years for tape), but anyway the market for tape recorders is growing fast. If a million recorders were actually in use, they would be showing up in corresponding proportions to radios and TV sets in service shops; because recorders have tubes and other components that are just as vulnerable to failure as those in receivers.

Prerecorded tapes are emerging slowly, feeling out this market. Be assured that someday, when enough of the people demand it, record shops will carry reels of tape recordings on their shelves right along with the 78's, 45's, and LP's.



**COLOR LINE.** Watched color TV sets roll down the line at the big Metuchen, New Jersey, Westinghouse plant. Final test was most interesting because of the variety of color patterns they get while aligning and adjusting for perfect color registry and balance. The line is in true production; but it is running slowly with only 35 of its scheduled 115 assembly workers — a typical practice with any new model, to train workers so that they in turn can train others and gradually bring the line up to rated output and speed.

Time for assembling and testing one of these 15-inch sets came to 16 1/2 hours, as compared to 5 1/2 hours for black-and-white sets on adjacent lines. This production time will come down fast when things get rolling.

\* \* Please turn to page 69 \* \*

# Before you buy another antenna insist on seeing the

Bill Clark, Hawkeye Sales, Des Moines, Iowa  
takes the "look-test."

using JFD super JeT antenna

using antenna A



1. Four TV receivers of one brand, same model, same production run were set up. Technicians went over these sets to make sure they were identically aligned.
2. Three other leading high gain TV antennas were installed—each oriented for maximum performance. Each antenna was connected to a set by identical type lead-in.
3. Each receiver was tuned with infinite care to the same channel to make certain the reception was as good as possible. The picture is the proof—the result can be immediately seen—the JFD Super JeT outperforms all others.
4. The chart shows why the "Look-test" is your proof positive of sharper, clearer, more brilliant pictures . . . in Black and White or Color on all channels present and future.

JeT 213 (Single Bay) \$18.70, list  
JeT 213S (2-Bay) \$38.35, list

JeT 213S-5\* (2-Bay "Super Power Jet") \$39.95, list  
\* $\frac{1}{2}$  WAVE WIDE-STACKED for up to 2 db. extra gain.  
Complete with mast supported stacking transformer.

Insist on the genuine JFD "SUPERJET"



# "look-test" yourself

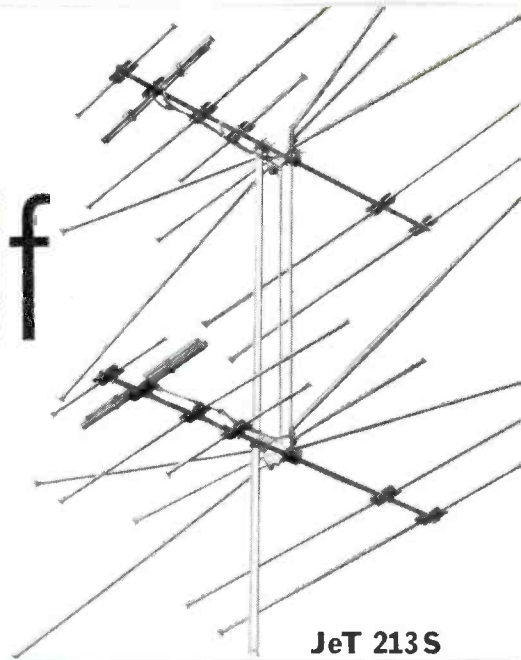

Here is your clinical proof that only the **JFD SUPERJET**

**TV antenna Out-Performs** all others on all channels

JeT 213S

using antenna B

using antenna C



## ANTENNA LIST

## CHANNELS

	2	3	4	5	6	7	8	9	10	11	12	13	
Competitor A Radar Screen with 3 dipoles (2-bay) Partly Pre-Assembled	\$42.36	4.5	4.3	7.3	7.0	7.0	10.00	10.75	11.5	11.7	11.0	11.5	11.6
Competitor B Radar Screen with 2 dipoles (2-bay) Not Assembled	\$34.95	0.75	3.25	4.5	3.5	3.5	6.0	7.0	6.5	7.75	8.0	7.5	6.0
Competitor C Bedspring (4-bay) Pre-Assembled	\$55.00	4.0	5.0	7.0	6.25	5.0	5.25	6.0	5.25	7.25	9.25	6.5	7.0
JFD Superjet Model JeT 213 S (2-bay) Pre-Assembled	\$38.35	6.5	7.5	9.5	8.5	8.5	11.0	11.0	12.0	12.0	11.25	11.75	12.0

DB GAIN



JFD Manufacturing Company,  
Brooklyn 4, N. Y.

World's largest manufacturer of TV antennas and accessories

Write for Bulletin #259



**Look for the Alcoa Aluminum Label**

# NOW

## THE ULTIMATE IN UHF CONVERTERS



### with Exclusive "Channelok" Circuit!

- Exclusive "Channelok" Circuit — Accepts Only Desired UHF Signal
- Lifetime Drift-Free Design — No Sliding Contacts
- Self-Powered — No Wiring to Borrow Power from Receiver
- Trouble-Free Tuning — Precision Micrometric Drive
- Universal Mounting — Top, Back, Side of Receiver

Now ITI brings you the finest conversion tuner on the market — the ITI Ultra-tuner — the *ultimate* in design, engineering, economy and dependability!

The Ultra-tuner provides the ideal solution to conversion problems in UHF areas. It *automatically* rejects other channels, VHF signals and all other sources of interference. Ghosts, smear, drift are problems of the past — optimum picture quality an everyday affair — with the easily tuned ITI Ultra-tuner.

If you're in a UHF area, this is the converter you should know about. See it at your jobber's today!

**\$18<sup>95</sup>**  
ONLY

For Catalog Sheet, Write



**INDUSTRIAL TELEVISION, INC.**

369 Lexington Avenue, Clifton, N. J.

# Television Sound IF Systems

(Continued from page 7)

If two tuned circuits are used, if they are tuned above and below the FM center frequency, and if they are connected to diodes in such a manner that their outputs oppose each other, then the useful portion of the curve is greatly extended and the response to amplitude variations is reduced.

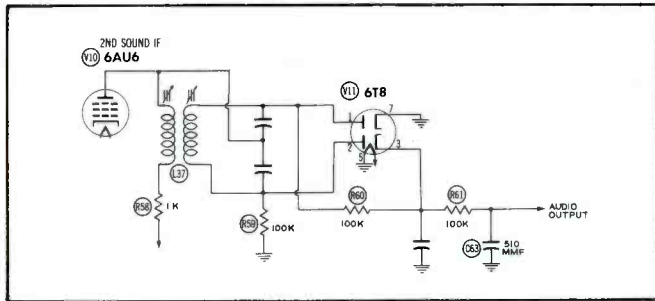

The resulting circuit, Fig. 10-12 is called a triple-tuned discriminator. This circuit is seldom encountered at present, since it has been replaced by some variation of the Foster-Seely discriminator which appears diagrammed in Fig. 10-13A.

## Foster-Seely Discriminator

Operation of the circuit may be explained as follows. The coupled, resonant circuits L1-C5 and L2-C4 are tuned to the incoming FM intermediate frequency. The center tap of L2 is effectively held at the same AC reference level as the plate side of L1 by means of C1, the reactance of which is relatively low at the intermediate frequency. The center tap of L2 is common to both diode circuits through R1. The voltage induced in L2 through L1 makes the ends of L2 of opposite polarity; therefore, the voltages applied to diodes 1 and 2 at resonance are of equal and opposite polarity, and the rectified voltages across R2 and R3 cancel in the output.

At resonance, the induced voltages across each half of L2 are 90

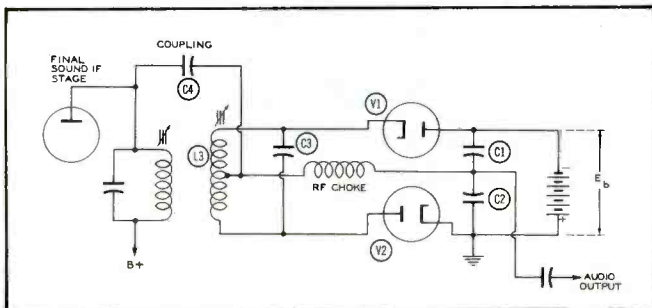
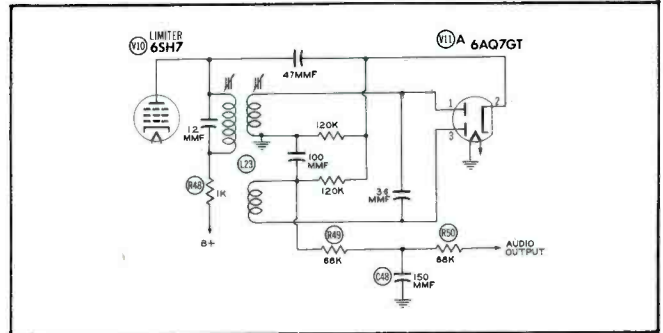
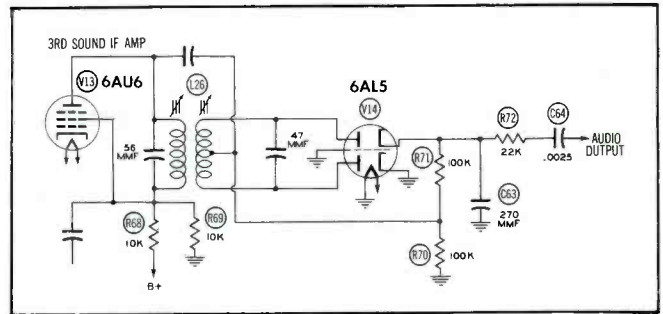

Fig. 10-15. Ratio-Detector Circuit Modified to Illustrate Principle of Operation.

Fig. 10-14. Variations of the Conventional Discriminator Circuit.



degrees behind or ahead of the voltage in L1. When the FM signal shifts above or below center frequency, the phase angle of the induced voltage departs an equal amount from 90 degrees but in opposite directions for each half of the secondary.

Note the vector diagrams in Figs. 10-13B, C, and D. In Fig. 10-13B, we have the example of signal resonance, with  $e_{s1}$  and  $e_{s2}$  at a 90-degree phase angle with  $e_p$ . The resultant voltages  $E_1$  and  $E_2$ , which are the vectorial sums of the voltages  $e_{s1}$  and  $e_{s2}$  with  $e_p$ , are equal and are applied to diodes 1 and 2 respectively. The resultant rectified voltages are equal but of opposite polarity; therefore, they cancel in the output.

In Fig. 10-13C, the signal is higher in frequency than at resonance, and the circuit L2-C4 is capacitive and  $e_{s1}$  and  $e_{s2}$  lag the position they originally occupied, as shown in Fig. 10-13B. The resultants  $E_1$  and  $E_2$  are unequal, and their difference will appear as a signal voltage in the output.

In Fig. 10-13D, the signal is lower in frequency than at resonance

and the tuned circuit L2-C4 is inductive, with  $e_{s1}$  and  $e_{s2}$  leading their original position, as shown in Fig. 10-13B. The resultants  $E_1$  and  $E_2$  are again unequal, but in opposite order, with their difference appearing as signal output.

It should be clear, then, that the output signal is the difference between rectified voltages across R2 and R3. If the difference is zero and the input signal doubles in magnitude, voltages across R2 and R3 double correspondingly and the difference remains at zero. This shows that the discriminator does not respond to amplitude modulation in the signal at the resonant frequency. At other frequencies  $E_1$  and  $E_2$  will be unequal, and their difference appears as signal output. If the input signal increases in amplitude,  $E_1$  and  $E_2$  increase in the same manner, their difference is also increased, and amplitude modulation has not been eliminated from the signal output. This illustrates the need for a limiter preceding the discriminator.

The values of C2 and C3 are such that the intermediate frequency is effectively bypassed around R2 and R3, but these values are not so large that the audio frequencies are affected.

Two variations of this basic circuit are shown in Figs. 10-14A and B. In each case, the circuit operation is essentially the same. In Fig. 10-14A, C63 substitutes for the two capacitors C2 and C3 of Fig. 10-13A. The remainder of the discriminator circuit is identical with Fig. 10-13A, although the schematic is drawn differently.

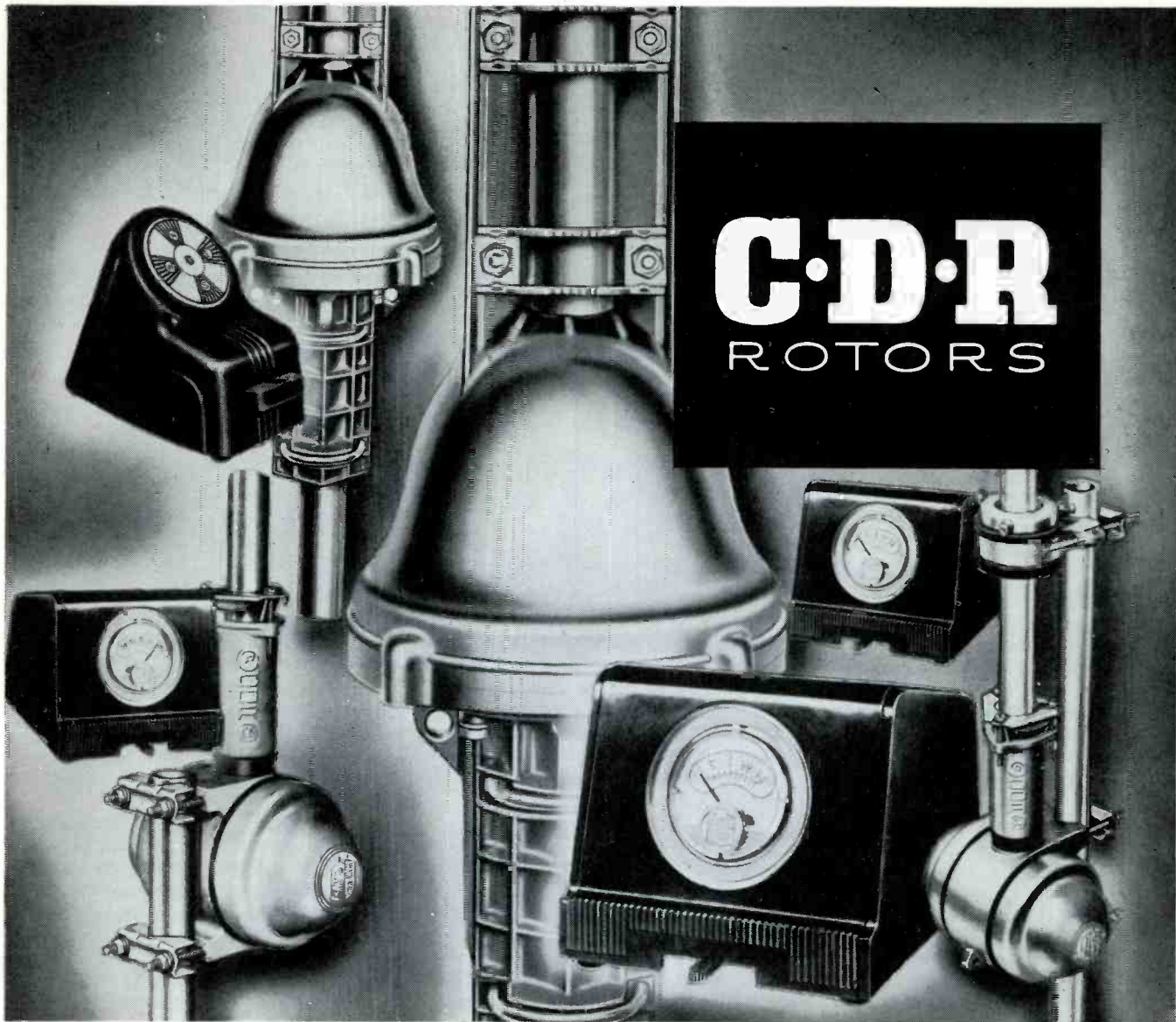

# C·D·R ROTORS

no other rotor offers **SO MUCH**

*a complete line*

**TR-2** the heavy duty rotor with compass control dial cabinet.

**TR-4** the heavy duty rotor with meter dial cabinet.

**TR-11** all purpose rotor with meter dial cabinet.

**TR-12** all purpose rotor for large TV antenna arrays with meter dial cabinet.

*widely promoted on TV*

widely promoted to consumers on TV... ALL CDR ROTORS are PRE-SOLD for you through an extensive campaign to millions every week exploiting the advantages of the CDR.

*completely merchandised*

completely merchandised... the easiest to sell... in addition to the TV spot coverage... there are newspaper mats, window streamers, envelope enclosures... and an animated point of sale display... all the tools you need to sell the BEST SELLING ROTOR!

**CORNELL-DUBILIER**  
SOUTH PLAINFIELD, N. J.



THE **RADIART** CORPORATION  
CLEVELAND 13, OHIO

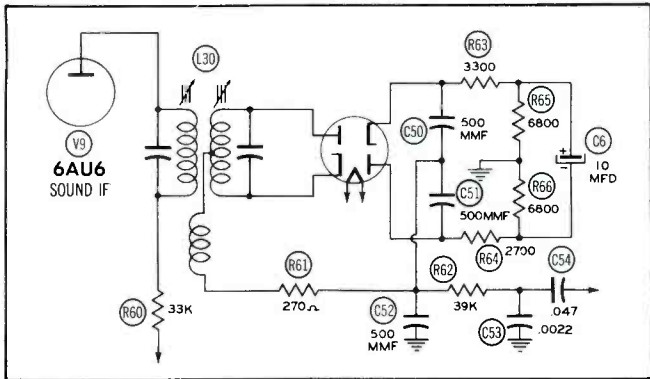
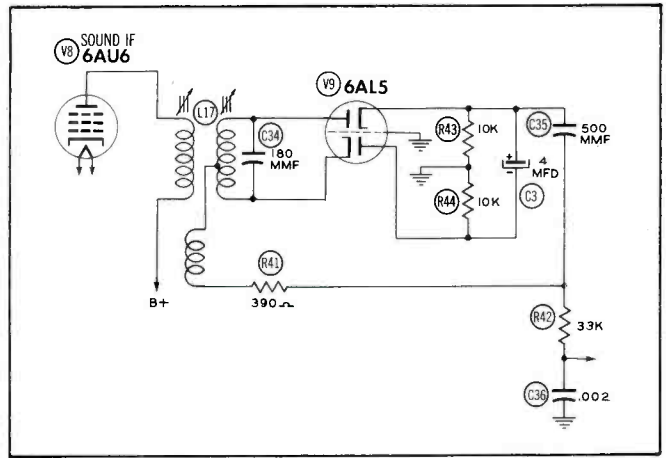
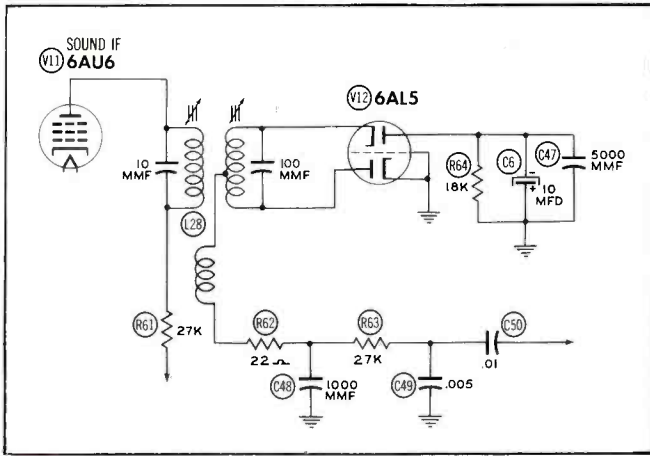

In Fig. 10-14B, there is no center tap on the secondary of the discriminator transformer. This point is established, however, by the junction of two capacitors in series which are placed across the secondary winding. When these capacitors are of equal value, the AC potential of the plate of V10 is effectively placed at the mid-point of the L37 secondary, as in the original discussion of discriminator theory. In some instances, these capacitors are of slightly different value to compensate for slight imbalance of other circuit components. Instead of R1 in Fig. 10-13A, an RF

choke may be used or both may be omitted entirely.

In Part I of this series, mention was made of the use of pre-emphasis at the transmitter, with compensating de-emphasis in the receiver to increase the signal-to-noise ratio in the higher audio frequencies. Standards of good engineering practice, as set forth by the FCC, require the use of a pre-emphasis network having a 75-microsecond time constant. The compensating de-emphasis network in the receiver therefore should also have

a 75-microsecond time constant. In practice, the actual value varies considerably and may be any value from 30 to 100 microseconds. R61 and C63 comprise this network in the example of Fig. 10-14B, and the time constant ( $R \times C$ ) in this case is 51 microseconds.

Fig. 10-14C shows one more variation of the discriminator, this one designed to utilize a duo-diode with common cathode.

### Ratio Detector

The most common form of FM detector at present is the ratio detector, and it is diagrammed in simplified form in Fig. 10-15. Its popularity is due to several advantages. A certain degree of amplitude limiting is inherent to its operation, reducing the need for limiter stages ahead of the detector; and, at the same time, the need for added amplification to operate the limiter stages is eliminated.

Fig. 10-15 is similar to Fig. 10-13A in several respects. However, the diodes are connected to the secondary in a different manner — a cathode and an anode are connected instead of both anodes as in the previous example. The diode load resistors have been replaced by a battery, and the audio output is taken off across C2.

The voltage developed across the series combination C1 and C2 is kept at a constant level by the battery (assuming little or no internal resistance). Each diode can be considered in effect as a variable resistance dependent upon the magnitude of the impressed signal voltage.

The signal voltage is applied to the diodes in the same manner as explained for the discriminator circuit of Fig. 10-13A; and the vector diagrams B, C, and D of the same figure also apply to the ratio detector as we have shown it. However, the sum of

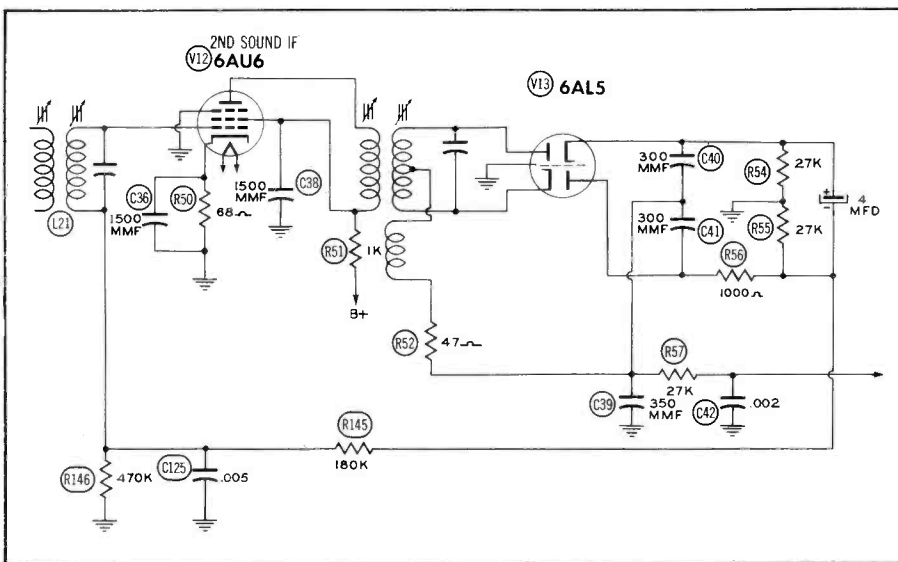

Fig. 10-17. Use of Ratio-Detector Load to Obtain AVC Voltage.

# Ready NOW!

## completely NEW STANCOR TV TRANSFORMER REPLACEMENT GUIDE

The new 1954 Stancor TV Replacement Guide and Catalog is a fully revised, up-to-the-minute listing of accurate transformer replacement data. Every recommendation has been rechecked against the latest information obtainable.

This Stancor reference lists over 6800 TV models and chassis of 115 manufacturers, including hard-to-locate information on "private label" sets.

To make your servicing easier, *virtually all flybacks, yokes and power transformers listed are exact replacements.* Where an exact replacement unit is not available, reference is made to the circuit or terminal changes required.



Stancor transformers are listed in Photofact Folders and Counterfacts.

## CHICAGO STANDARD TRANSFORMER CORPORATION

3584 Elston Avenue Chicago 18, Illinois

EXPORT SALES: Roburn Agencies, Inc., 39 Warren Street, New York 7, N. Y.



If you haven't received your copy, see your Stancor distributor, or write us directly.

## STANCOR-WILLIAMSON ULTRA-LINEAR HI-FI amplifier bulletin 479

Build your own ultra-linear hi-fi amplifier using Stancor high fidelity output transformer A-8072 (\$15.00 net). You can also use A-8072 to convert your present Williamson amplifier to ultra-linear operation. Bulletin 479, available FREE, contains performance curves, schematics, parts lists, chassis layouts and other helpful construction and conversion information.

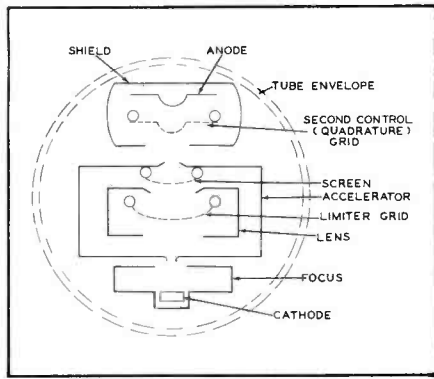

**Fig. 10-18. Diagram of Internal Structure of 6BN6 Gated-Beam Tube.**

the voltages  $E_1$  and  $E_2$  will always equal  $E_b$  (Fig. 10-15). As the signal varies on either side of the center frequency to which the transformer is tuned,  $E_1$  and  $E_2$  will vary in relation to each other; that is, their sum will be constant, but their ratio will change. This ratio appears across C2 and is taken off as audio output. An increase in amplitude of the input signal does not appear in the detector output because of the limiting effect of the battery. For this reason, the ratio detector does not require the use of a limiter in preceding stages.

In practice, a battery is not used as indicated. It would be necessary for the input signal to be great enough to overcome the battery potential before the diodes would conduct. Instead, a load resistor and a shunt capacitor are employed (R64 and C6 in Fig. 10-16A). The time constant is such that audio signals are bypassed, yet slow variations in carrier strength are followed. In this manner, the average value of the received carrier determines the magnitude of charge of C6.

With weak input signals, the diodes are still able to conduct; and with stronger signals, the higher

average value of charge on C6 permits an audio output signal of greater amplitude.

In Fig. 10-16A the tertiary winding of L28 (bottom winding in the schematic) is the means of transfer of the reference voltage from the primary. C1 of Fig. 10-15 has been omitted, and C2 is represented by C48. R62 is a current-limiting resistor to improve the AM rejection of the circuit. R63 and C49 make up the de-emphasis filter.

The circuit shown in Fig. 10-16A is called an unbalanced detector, because one end of the diode load resistor is grounded. A balanced type is shown in Fig. 10-16B. In this circuit, the mid-point of the load resistor is grounded.

Although the ratio detector has a built-in AM-rejection characteristic, there may still be undesirable AM signals passed through the system, especially when large signals are handled or when the system is unbalanced dynamically. R63 and R64 are used to obtain a more exact balance, as shown in Fig. 10-16C, where it will be noted that they are of unequal value. The sensitivity of the detector is slightly reduced by using this method. In some variations, R61 is made variable in order to serve as an adjustable balance control.

Some manufacturers use a small amount of limiting ahead of the ratio detector in order to gain some noise and amplitude rejection on large signals. AVC may be used to reduce the gain of the IF strip, in order to prevent unnecessarily large signals from reaching the detector. The AVC voltage may be obtained from the stabilizer capacitor in the detector load.

Fig. 10-17 illustrates the use of AVC obtained in the manner mentioned previously. The AVC voltage is taken off the negative end of C5, passes through the filter network comprised of R145 and C125, and is applied through the secondary of L21 to the grid of V12. R146 serves as the grid-return resistor and is part of a voltage-divider network, R145 and R146, which reduces the voltage from C5 the proper amount for application to the grid of V12. R56 is another example of a balancing resistor in a ratio-detector circuit.

### Gated-Beam Tube

An FM detector of more recent design than either the discriminator or ratio detector types involves the use of a 6BN6 tube, commonly referred to as a gated-beam tube. A diagram of the position and nature of the tube elements is shown in Fig. 10-18. The focus, lens, and shield structures are connected internally to the cathode. The electron stream emitted by the cathode is formed into a narrow beam by the focus structure and passes through the slot in the accelerator to approach the limiter grid. If this grid is sufficiently negative, no plate current will flow. As the grid is slowly made less negative, a critical value is reached at which time the plate current suddenly rises to a maximum value; and further increase of grid voltage in a positive direction will not result in increased plate current. This property of the tube enables it to perform a very effective limiting action.

The electron stream is refocused by the lens structure and by the slight curvatures of the limiter grid and the screen grid; and it passes on towards the quadrature grid and anode. If the quadrature grid is sufficiently negative, the plate current will still be cut off. The action of each grid may be likened to that of a gate. If either gate is closed (negative), the electron stream is cut off; and if both gates are open, the plate current cannot rise above a certain value no matter how positive the grids may go. Fig. 10-19 shows a circuit using a 6BN6 as the limiter-discriminator in a television receiver. The limiter grid connected to pin 2 is biased at zero volts. During negative half-cycles of sufficient amplitude, the beam is cut off. The resulting intermittent beam passes through the second accelerator and forms a varying space charge in front of the second control grid or quadrature grid connected to pin 6. Space-charge coupling (electrostatic induction) induces a current in the ground return of the quadrature grid and develops a voltage across the tuned quadrature

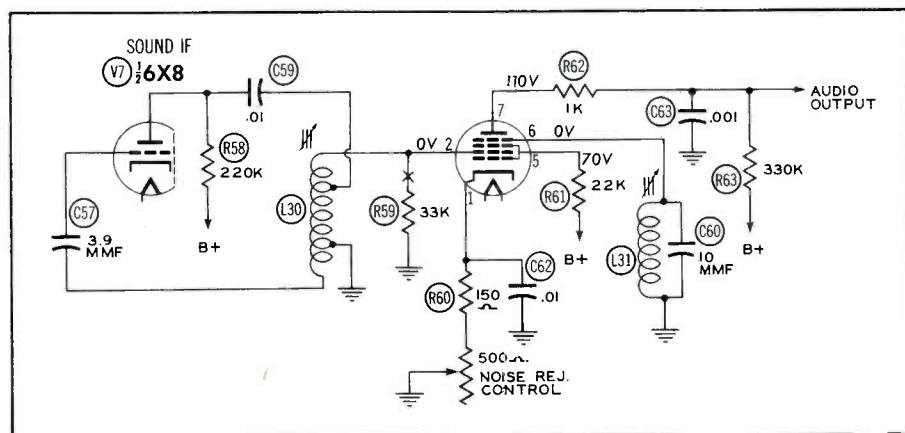

**Fig. 10-19. Partial Schematic Showing Use of 6BN6 Tube as an FM Limiter-Detector in a TV Receiver.**

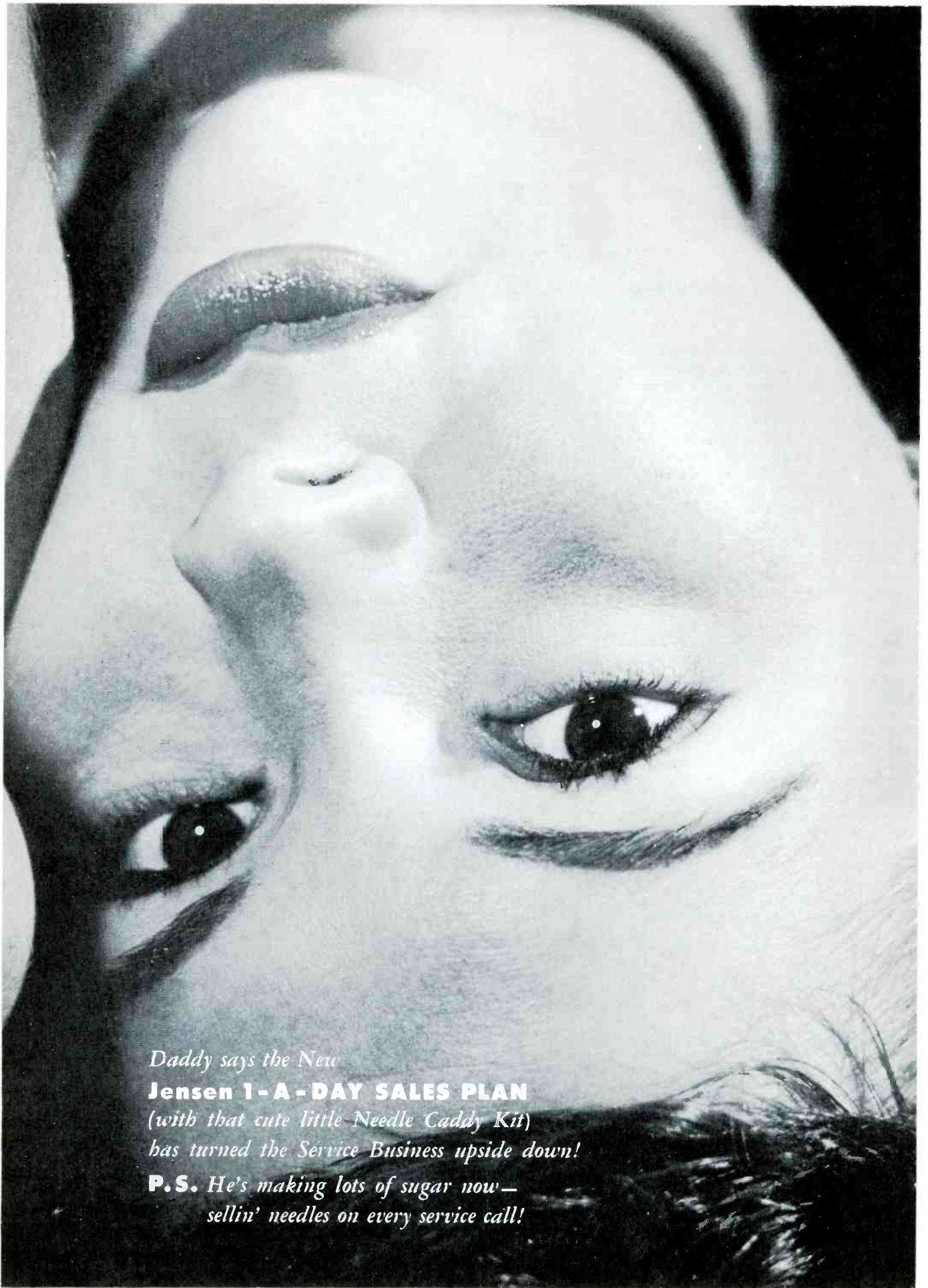

*Daddy says the New*  
**Jensen 1-A-DAY SALES PLAN**  
*(with that cute little Needle Caddy Kit)*  
*has turned the Service Business upside down!*  
**P.S.** *He's making lots of sugar now —*  
*sellin' needles on every service call!*



circuit composed of L31 and C60. When the quadrature circuit is at resonance with the incoming signal, the voltage across the circuit lags by approximately 90 degrees the voltage at the limiter grid. As the frequency varies from resonance, the quadrature voltage will lag more or less than 90 degrees.

In order to use the gate analogy further, we have two gates opening and closing periodically with the second lagging the first. The beam current starts with the opening of the second gate and ends with the closing of the first. Duration of the current flow depends upon the amount of lag

of the second gate, which amount in turn depends upon the variation of the signal input frequency. An audio-frequency variation corresponding to the frequency modulation in the signal is developed across the plate-load resistor R63 and is applied to the audio stages of the receiver. Normally this audio signal is sufficient to drive the output stage without further amplification.

C63 bypasses the intermediate frequency to ground. Normally, its value will be such that it also provides the correct amount of de-emphasis. R62 ranges in value from 300 to 1,000 ohms in most receivers.

It is referred to as the plate linearity resistor and develops a pulsed voltage which appears on the plate of the 6BN6. This voltage is coupled through the tube to the quadrature grid where it reinforces the voltage already induced there by space-charge coupling. The effect of this feedback voltage is to improve the AM-rejection characteristics of the circuit and to minimize distortion in the audio output. For best AM rejection, the tube should be operated at the correct bias point; and an adjustment, the noise-rejection control, is provided for that purpose.

Paul C. Smith

## Color TV Training Series

(Continued from page 11)

through glass than does light of longer wavelengths. Fig. 1-4 shows the relationship of the wavelengths and the colors of the light spectrum. The spectrum ranges from violet on the lower end to red on the upper end. In between fall blue, green, yellow, and orange. A total of six distinct colors are visible when passing white light through a prism. Since the colors of the spectrum pass gradually from one to the other, the theoretical number of colors becomes infinite. It has been determined that about 125 colors can be identified over the visible gamut. Fig. 1-5 shows the light spectrum in full color.

### How Color Appears to the Eye

We have shown how light possesses various wavelengths covering the visible spectrum and how the spectrum is divided into various colors. Even though the colors which make up a white light may be of equal intensities, the human eye does not perceive each color with equal efficiency. This fact is due in some way to the physical construction of the eye. It is believed that the cones of the retina respond to color stimuli and that each cone is terminated by three receptors. Each receptor is believed to respond to a different portion of the spectrum, with peaks occurring in the red, green, and blue regions, respectively. An average can be taken of the color response of a number of people, and a standard response for an average person can be derived. This standard response is shown in Fig. 1-5 and is called the luminosity curve for the standard observer.

An inspection of this luminosity curve will show that it is a plot of response versus wavelength. This is the same type of plot that is often used to describe the performance of a tuned resonant circuit in which maximum response occurs at the resonant frequency and response falls off on either side of resonance. With this in mind, we can look at the luminosity curve and see that maximum response occurs at a wavelength of approximately 555 millimicrons and that less response is indicated on either side of that point. From this information, one may see that the average person's eye is most sensitive to light of a yellowish-green color and is less sensitive to blue and red lights.

There are three color attributes which are used to describe any one color or to differentiate between several colors. These are: (1) hue, (2) saturation, and (3) brightness. Hue is a quality which is used to identify any color

under consideration, such as red, blue, or yellow. Saturation is a measure of the absence of dilution by white light and can be expressed with terms such as rich, deep, vivid, or pure. Brightness defines the amount of light energy which is contained within a given color.

We might consider an analogy between a color and a radiated radio wave. Hue, which defines the wavelength of the color, would be synonymous to frequency, which defines the wavelength of the radio wave. Saturation, which defines the purity of the color, would be synonymous to signal-to-noise ratio, which defines the purity of the radio wave. Brightness, which is governed by the amount of energy in the color, would be synonymous to amplitude, which defines the amount of energy in the radio wave.

Brightness is a characteristic of both white light and color, whereas hue and saturation are characteristic of color only.

Saturation and brightness are often visualized as identical or interrelated qualities of color, whereas they should be considered as separate qualities. It is possible to vary either one of these qualities without changing the other. We might cite an example using an instrument which is familiar to the service technician.

A service oscilloscope presents a green trace on the face of the tube; this trace can be varied in brightness from visual extinction to a maximum brightness by rotation of the intensity control. An observer can become confused by the fact that the green color appears to be greener at low-intensity levels than it is at higher intensities. This is often interpreted as an increase in saturation at the low-intensity level. Actually, however, neither the hue nor the saturation of the trace color can change since these qualities are determined by the chemical properties of the phosphor. The brightness of the

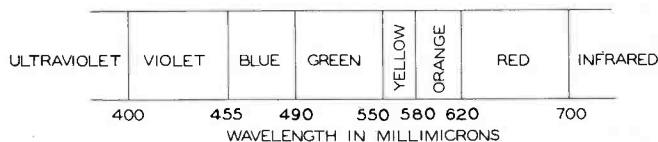

Fig. 1-4. Relationships Between Colors and Wavelengths in the Light Spectrum.

trace is the only variable when the intensity control is rotated. The deceiving change in saturation is due to a change in the color response of the eye at low-intensity levels and is often confusing to one who does not know the true reason for this illusion.

In the foregoing example, a case was cited wherein the brightness level was varied without changing the saturation. Conversely, the saturation of a given color can be changed without varying the brightness, providing certain requirements are met during the process.

In nature, however, a change in saturation is usually accompanied by a change in brightness. This is exemplified by the fact that a pastel color generally appears brighter than a saturated color of the same hue when they are directly lighted by the same source. By changing the lighting on the pastel color (such as by placing it in a shadow), one can decrease the brightness of the pastel color; and it is conceivable that both colors can be made to have the same brightness. Thus, two colors of the same hue but of different saturation can have equal brightness levels.

Any given color within limitations can be reproduced or matched by mixing three primary colors, as will be explained later. This applies to large areas of color only. Color vision for small objects or small areas is much simpler, because only two primary colors are needed to produce any hue. This is due to the fact that as the color area is reduced in size the various hues blend into one another until, for very small areas, every hue appears as gray. At this point, a change in hue is not apparent; only a change in brightness level can be seen.

Another aspect of color vision is closely related to the persistence of vision exhibited by the human eye. If two objects of different hues are placed side by side and are shuttled back and forth at a sufficiently rapid rate, the two hues will appear as a third hue. This is true for both large and small objects.

### **Color Mixture**

The production of color may be accomplished by either of two processes. When working with paint pigments, the subtractive process is employed. The other process of mixing colors is called the additive process. This is the process that is employed in color television. These two methods of producing color are rather different. It might be said that the additive process is just the reverse of the subtractive process.

The subtractive process is dependent upon incident light. Light falling upon a painted picture is reflected or absorbed. If a certain section of the picture is treated with a red pigment, the light which is reflected is predominantly in the red region of the spectrum and the section will appear red.

The additive process of color mixing used in color television employs colored lights for the production of colors. The colors in the additive process do not depend upon an incident light source. Self-luminous properties are characteristic of the additive colors. Phosphorescent signs which glow in the dark are good examples of this process. Cathode-ray tubes contain self-luminance properties, so it is only logical that the additive process would be employed in color television.

The three primaries for the additive process of color mixing are red, green, and blue. Two requirements for the primary colors are that each primary must be different, and that the combination of any two primaries must not be capable of producing the third. Red, green, and blue were chosen for the additive primaries because they fulfilled these requirements and because it was de-

termined that the greatest number of colors could be matched by the combination of these three colors.

Shown in Fig. 1-6 are the three additive primaries used in color television. Fig. 1-6A shows the primaries as three separate colored lights. Addition of the three colored lights is shown in Fig. 1-6B. When all three primaries are combined in a definite proportion, white is produced. Red and green combine to make yellow. The combination of red and blue produces magenta (bluish-red), while blue and green combine to make cyan (greenish-blue). Yellow, magenta, and cyan are the secondary colors that are the complements of blue, green, and red, respectively. When a secondary color is combined with its complementary primary, white is produced. For example, combining yellow with blue produces white. Cyan added to red results in white, and magenta plus green gives white. Carrying this one step further, the complementary colors when added together produce white. It should be mentioned that specific proportions of these colors must be used in order to produce white.

The foregoing points are shown diagrammatically in Fig. 1-7. From this diagram we can see that by mixing colors in certain proportions, we can obtain the following expressions:

Red + Green = Yellow,

Red + Blue = Magenta,

Blue + Green = Cyan,

Yellow + Blue = White,

Cyan + Red = White,

Magenta + Green = White,

Since yellow plus blue equals white and red plus green equals yellow,

then

Red + Green + Blue = White.

Since the addition of the three primaries can produce white, the addition of the correct proportions of the three complementaries which are made up of the three primaries can also produce white.

Therefore:

Cyan + Magenta + Yellow = White.

It is not necessary to overlap the primary colors in the additive process to produce a different color. Two sources of colors may be placed in close proximity to each other, and at a certain viewing distance the two colors will blend together and produce the new color. The eye actually performs the additive process. This is referred to as the juxtaposition of color sources. For example, if blue and green are positioned close to each other but not overlapping, the two colors will be blended by the eye and will be seen as cyan when viewed from a distance.

Each additive primary contributes a certain percentage of the brightness in the white which results from mixture. Green is the brightest of the three primaries, red is the second brightest, and blue is the dimmest. This has been determined through experimentation with the response of the eye. The eye responds more to green than to any of the other primary colors. With the total

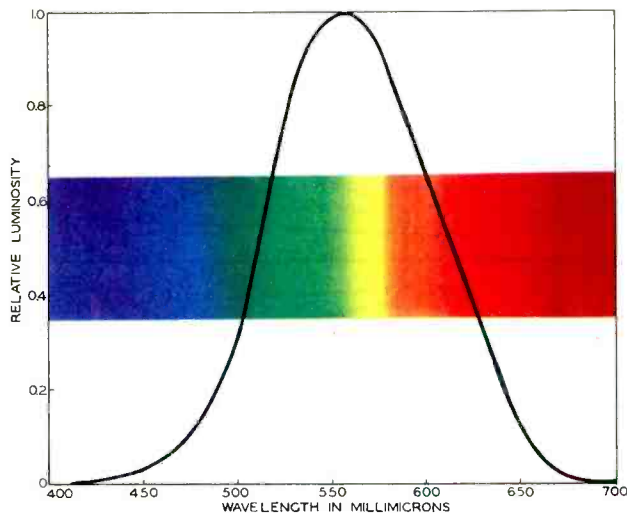

**Fig. 1-5. Luminosity Response of the Eye With Respect to the Colors of the Light Spectrum.**

brightness of white considered as unity, green contributes 59 per cent of the total, red 30 per cent, and blue 11 per cent. Therefore, when combining green with red we have a yellow with a brightness value of 89 per cent. Cyan has a brightness of 70 per cent. This results from 59 per cent of brightness from green and 11 per cent of brightness from blue. The third complementary color, magenta, has a brightness of 41 per cent. It obtains 30 per cent from red and 11 per cent from blue. Yellow contains the highest per cent of brightness of all of the primary colors and their complements, whereas blue contains the least amount of brightness. The order of brightness for each color is shown in Fig. 1-6B.

There are eight basic rules of colorimetry which apply to the process of color matching. These rules are stated along side of Chart I which contains an illustration applying to each rule. A knowledge of these rules is very helpful in understanding how matching of colors can be accomplished when using three primary colors.

### Color Specifications

Standards are necessary in all phases of industry. Imagine the great amount of confusion that would result in the television industry if certain standards of design and construction were not followed. A telecast conforming to one set of transmission specifications could not be received on a receiver designed for reception of a signal having different specifications. Similar difficulties would exist in the specification of colors if standards were not adopted. You can imagine the dismay of someone trying to describe over the telephone the color of a paint that is needed to match a particular color. Such terms as purple, purplish-red, or bluish-purple might be used, but they would certainly not be adequate. The result of such a nonstandardized match would probably be far removed from the original color.

Standards for the specification of color were adopted by the Commission Internationale de l'Éclairage (CIE) at a meeting in 1931. (The English translation of this French name is International Commission on Illumination.) These standards provide that the red primary shall correspond to a light of a wavelength of 700 millimicrons, green to a wavelength of 546.1 millimicrons, and blue to a wavelength of 435.8 millimicrons.

In the development of a color matching and specification system, extensive color matching tests on many

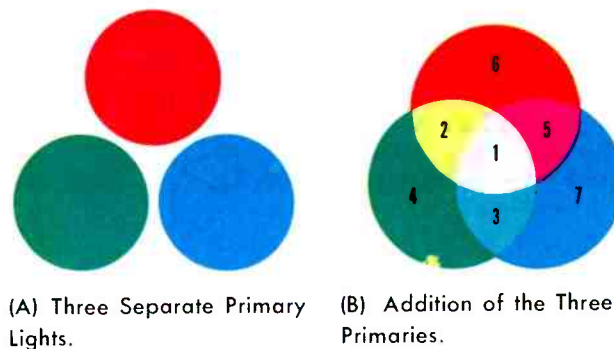

**Fig. 1-6. Additive Light Primaries.**

observers were conducted using a colorimeter. This is a device which incorporates a photoelectric screen and a series of filters and optical lenses. The method used in these color matching tests was as follows: one-half of the colorimeter screen was illuminated with a spectral hue from a standard source of white light. The hue which was to be matched by the observer was obtained by projecting the light from the standard source through a prism. The hue was selected by moving a plate with a very narrow slit into position so that only the desired hue was allowed to illuminate the colorimeter screen. The other half of the colorimeter screen was then illuminated selectively by the observer with spectral hues of the three additive primaries — red, green, and blue. By the use of independent controls, the energies contributed by each of the primaries were varied by the observer until a color match was thought to be obtained. Each observer was subjected to a series of tests which constituted attempts to match several selected colors. In order to establish an average which could be considered as that of a standard observer, many persons were used with each performing similar tests. The results of these tests are known as tristimulus values for color mixture curves and are illustrated in Fig. 1-8.

Tristimulus values are defined as the amounts of the primaries (red, green, and blue) that must be combined to effect a color match with all the different colors

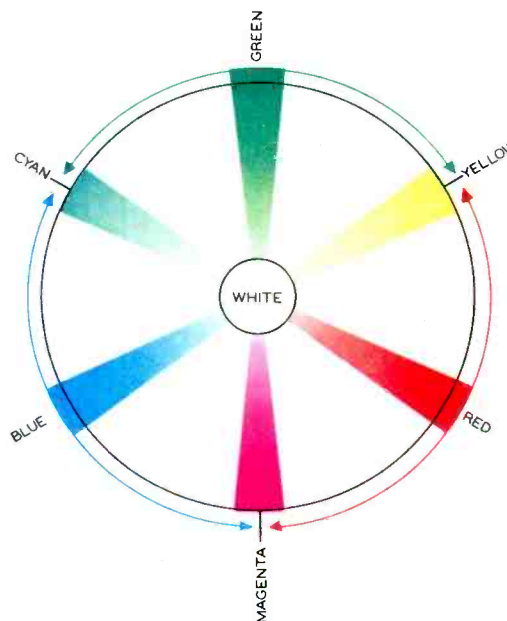

**Fig. 1-7. A Color Circle.**

### CHART I. Color Matching Rules.

1. Any color, with limitations, can be matched by a mixture of three colored lights.

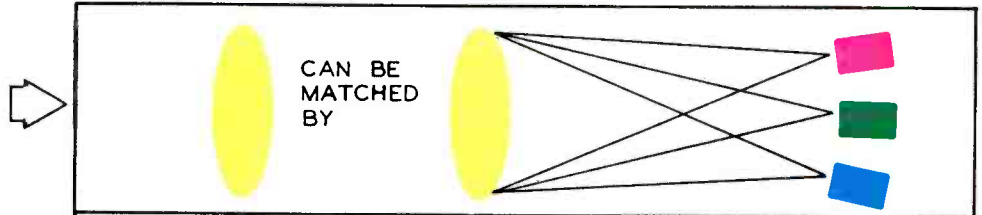

2. The individual colors which make up a mixture cannot be resolved by the eye.

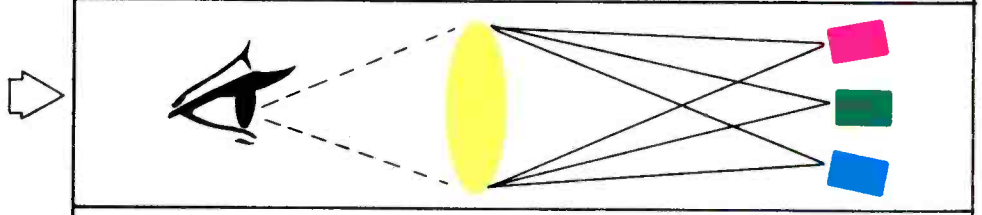

3. The total brightness of a mixture is equal to the sum of the individual brightnesses of all colors in the mixture.

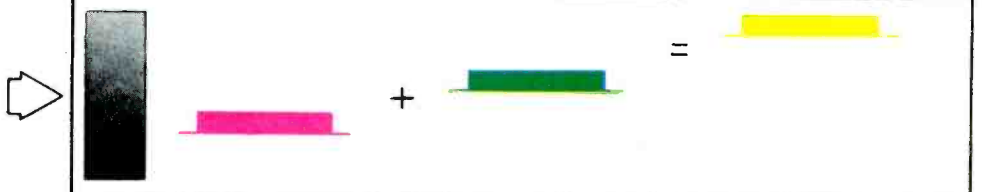

4. If a color match is obtained at one brightness level, the match will be maintained over a wide range of brightness levels. If the brightness of the color to be matched is doubled, a perfect color match will be maintained if the brightness of each color in the matching mixture is doubled.

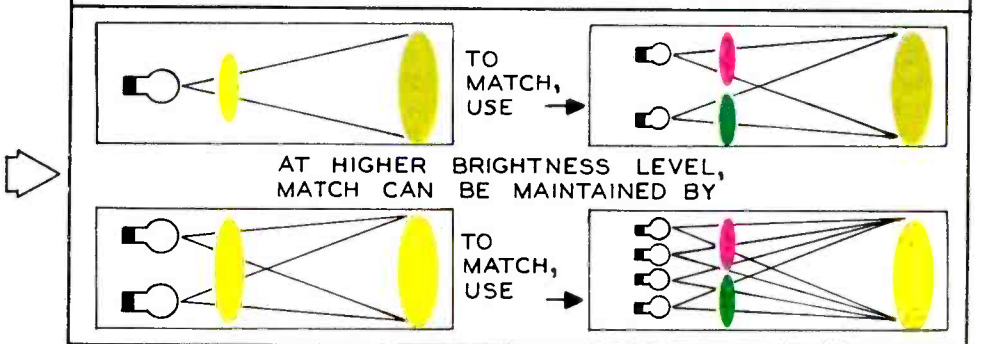

5. A color equation can be used to express the formation of a color match. If a color (C) is formed by adding M units of color (M), N units of color (N), and P units of color (P), the resulting mixture can be written:

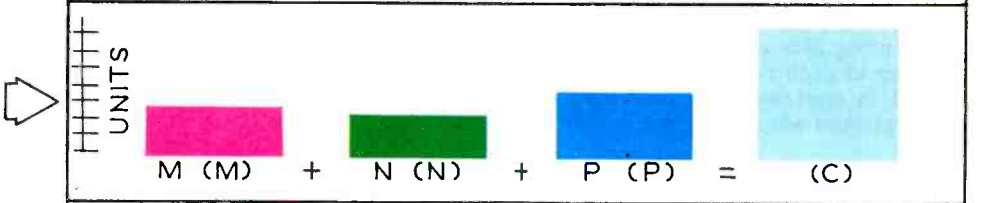

$$(C) = M(M) + N(N) + P(P).$$

6. Color matches obey the law of addition.

If  $(M) = (N)$   
and  $(P) = (Q)$   
then  $(M) + (P) = (N) + (Q)$ .

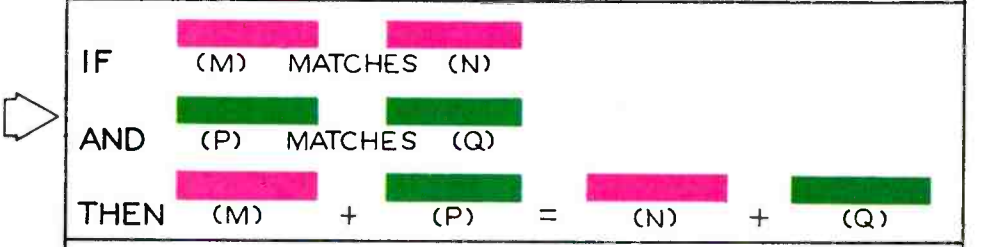

7. Color matches obey the law of subtraction.

If  $(M) + (P) = (N) + (Q)$   
and  $(P) = (Q)$   
then  $(M) = (N)$ .

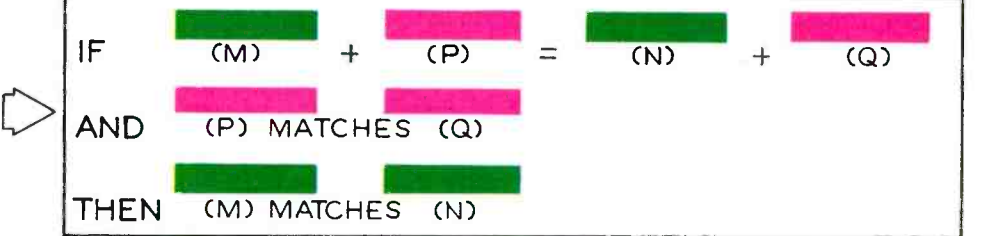

8. Color matches obey the transitive law.

If  $(M) = (N)$   
and  $(N) = (P)$   
then  $(M) = (P)$ .

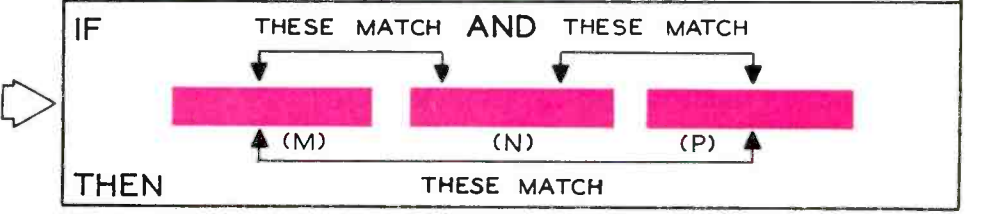

in the visible spectrum (400 millimicrons to 700 millimicrons). As an example of how this graph is used, let us select a color which has a wavelength of 520 millimicrons. The amount of the three spectral primaries needed to match this color can be read from the color mixture curves. From the graph it can be seen that approximately .09 of red, .09 of blue, and .7 of green are needed to correctly match the color that is specified as having a wavelength of 520 millimicrons.

The data contained in the color mixture curves is not very practical for the specification of all colors. These curves contain information that is required to determine the amounts of the spectral primaries that are needed to match any saturated spectral color. They do not provide information necessary for the matching of desaturated colors. Therefore, the need for a more useful means of specifying color is evident.

By the use of mathematical equations, the information contained in the color mixture curves has been converted to a graphical representation of color on a three-dimensional plane. The conversion equations used to derive the three-dimensional coordinate values  $x$ ,  $y$ , and  $z$  are the following:

$$x = \frac{\bar{x}}{\bar{x} + \bar{y} + \bar{z}} \quad (1)$$

$$y = \frac{\bar{y}}{\bar{x} + \bar{y} + \bar{z}} \quad (2)$$

$$z = \frac{\bar{z}}{\bar{x} + \bar{y} + \bar{z}} \quad (3)$$

where

$\bar{x}$  = values on the red color mixture curve,

$\bar{y}$  = values on the green color mixture curve,

$\bar{z}$  = values on the blue color mixture curve.

By taking values for  $\bar{x}$ ,  $\bar{y}$ , and  $\bar{z}$  from the color mixture curves at different wavelength intervals and solving for  $x$ ,  $y$ , and  $z$ , the results can be used to plot a three-dimensional color diagram.

Following are a few examples of these computations:

For a green color of 560 millimicrons, the values of  $\bar{x}$ ,  $\bar{y}$ , and  $\bar{z}$  (as taken from the graph shown in Fig. 1-8) are  $\bar{x} = .6$ ,  $\bar{y} = 1$ , and  $\bar{z} = 0$ . Substituting these values of  $\bar{x}$ ,  $\bar{y}$ , and  $\bar{z}$  into equations 1, 2, and 3, we obtain:

$$x = \frac{.6}{.6 + 1 + 0} = .375,$$

$$y = \frac{1}{.6 + 1 + 0} = .625,$$

$$z = \frac{0}{.6 + 1 + 0} = 0.$$

For a blue color of 480 millimicrons the values of  $\bar{x}$ ,  $\bar{y}$ , and  $\bar{z}$  (as taken from the graph of Fig. 1-8) are  $\bar{x} = .1$ ,

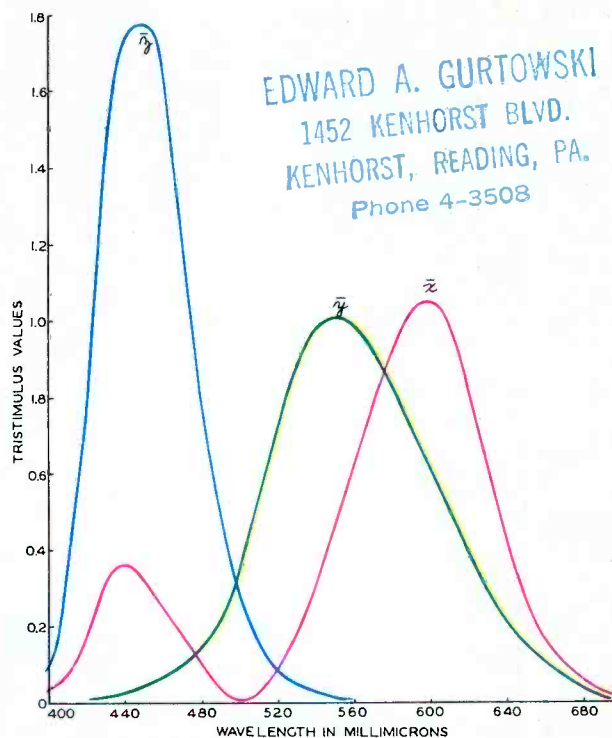

Fig. 1-8. Color-Mixture Curves.

$\bar{y} = .15$ ,  $\bar{z} = .78$ . Again substituting these values into equations 1, 2, and 3, we obtain:

$$x = \frac{.1}{.1 + .15 + .78} = .097,$$

$$y = \frac{.15}{.1 + .15 + .78} = .146,$$

$$z = \frac{.78}{.1 + .15 + .78} = .757,$$

$$.097 + .146 + .757 = 1.$$

For a red light of 600 millimicrons the values of  $\bar{x}$ ,  $\bar{y}$ , and  $\bar{z}$  are

$$\bar{x} = 1.06, \bar{y} = .62, \text{ and } \bar{z} = 0.$$

Solving, we obtain:

$$x = \frac{1.06}{1.06 + .62 + 0} = .63,$$

$$y = \frac{.62}{1.06 + .62 + 0} = .37,$$

$$z = \frac{0}{1.06 + .62 + 0} = 0.$$

If the procedure is repeated at regular intervals from 400 to 700 millimicrons, the results can be used to plot the curve shown in Fig. 1-9. This curve represents color in three dimensions and is referred to as the Maxwell triangle.

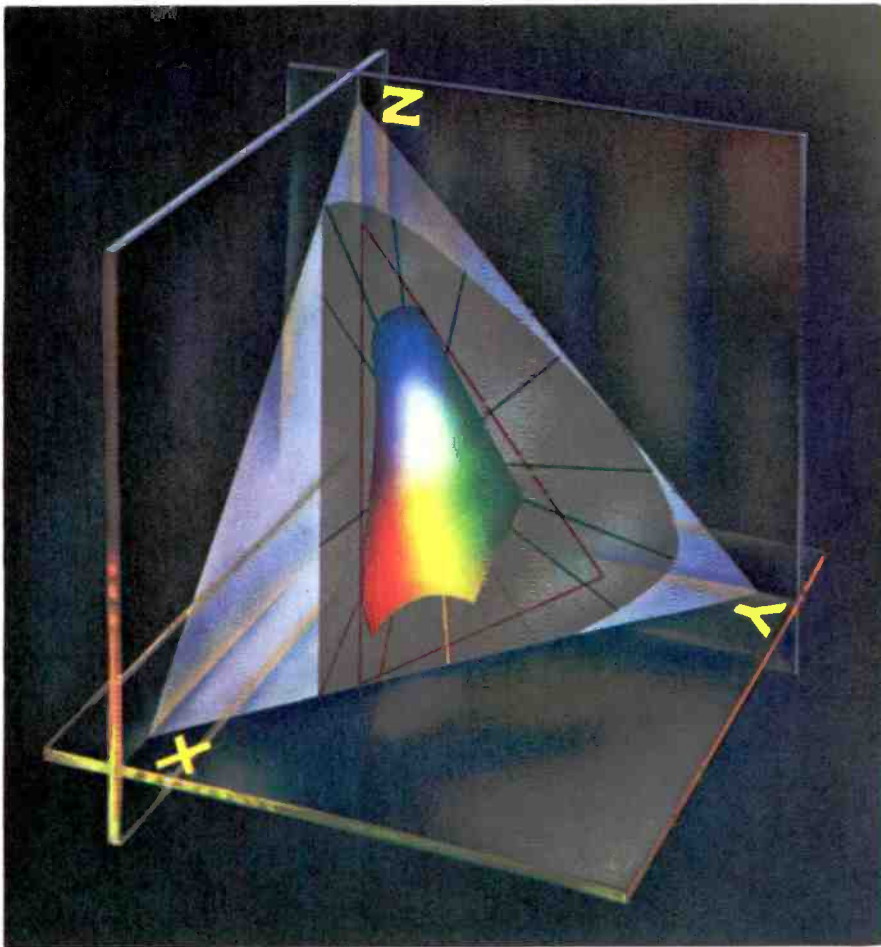

Fig. 1-9. The Maxwell Triangle.

By using the proper equations, the values obtained from the color-mixture curves can be converted to values of  $x$ ,  $y$ , and  $z$ . These values can then be plotted in terms of  $X$ ,  $Y$ , and  $Z$ ; the three-dimensional curve shown in Fig. 1-9 will result.

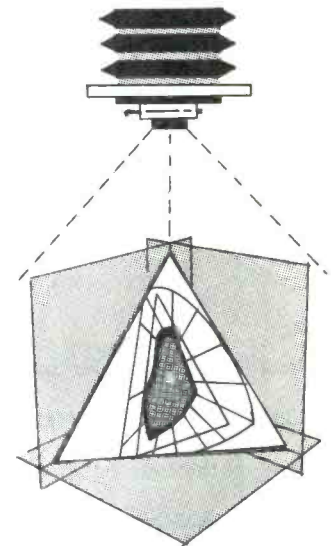
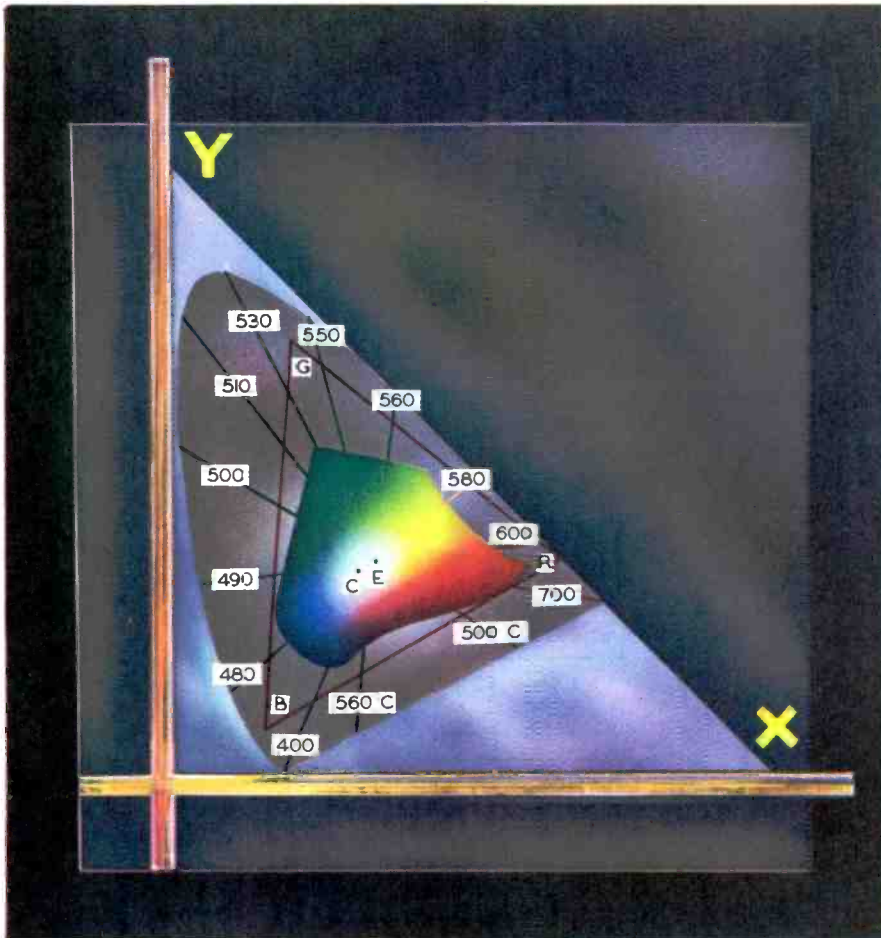

Fig. 1-10. The CIE Chromaticity Diagram and the NTSC Triangle.

The diagram is a result of the projection on the  $X$ - $Y$  plane of the three-dimensional curve shown in Fig. 1-9. This projection can be accomplished by photographing the structure with the camera in line with the  $Z$ -axis. To visualize how this is done, assume the camera position to be directly above the  $Z$ -axis. The resultant photograph will be that shown in Fig. 1-10.

The ratios shown in equations 1, 2, and 3 were set up so that the values for  $x$ ,  $y$ , and  $z$  at any wavelength would equal unity when added together. This means that at all times  $x + y + z = 1$ . This can be checked by adding together the results obtained in each example which was previously shown. For instance, in the first of the foregoing examples,  $x = .375$ ,  $y = .625$ , and  $z = 0$ . It can be seen from this that  $x + y + z = 1$ .

Since  $x + y + z = 1$ , a similar curve can be shown on a two-dimensional plane; and this curve constitutes a more useful diagram than that shown in Fig. 1-9. Any two of the quantities  $x$ ,  $y$ , and  $z$  are sufficient to specify a chromaticity. The third quantity can be found, since  $x + y + z = 1$ . By plotting only the values for  $x$  and  $y$  on the X-Y plane or by projecting the curve of Fig. 1-9 to the X-Y plane, the result is as shown in Fig. 1-10. The curve in this illustration is called the "CIE Chromaticity Diagram." The projection shown in Fig. 1-10 was accomplished by photographing the structure shown in Fig. 1-9 from above and on the Z-axis. This eliminated the dimension on the Z-axis and provided a proportionate diagram having only X and Y axes. The two-dimensional CIE chromaticity diagram shown in Fig. 1-10 is used extensively in the specification of color, since all colors contained within the locus of the CIE diagram can be specified in terms of X and Y.

If we examine the diagram in Fig. 1-10, we see that the horseshoe curve, which is known as the spectrum locus, is graduated into numerals ranging from 400 in the left-hand corner to 700 at the extreme right. These figures represent the wavelengths of the various colors in millimicrons; the blues (including violet) extend from approximately 400 to 490 millimicrons, the greens extend from approximately 490 to 550 millimicrons, the yellows extend from approximately 550 to 580 millimicrons, and the reds (including orange) extend from approximately 580 to 700 millimicrons.

Any point which is not actually on the spectrum locus but which lies within this diagram can be defined as some mixture of spectrum colors. Since white is such a mixture, it falls within this area.

It might be well to point out that there is another method of specifying colors near the white region. This method uses degrees Kelvin to designate a particular color. (Degrees in Kelvin equal degrees in Centigrade plus 273.) All of us have seen metal heated to various temperatures, and we have seen how it will change in color from a dull cherry red into a white as the temperature is increased. If we increase the temperature still further, the metal will take on a decidedly bluish cast. These colors can be shown on the chromaticity diagram if we draw an imaginary arc starting in the reddish region on the right side of the diagram and extending up through the orange into the white area and down toward the bluish region to the left. Such facts are of importance when we look at the three standard sources of light and how they were specified by the CIE. These three standard sources of light were chosen for measurement purposes; and they are known as illuminant A, illuminant B, and illuminant C.

Illuminant A was selected as a match in color to a conventional tungsten lamp. To achieve this, a tungsten filament was heated to approximately 2500 degrees Kelvin.

Illuminant B was selected to give an approximate match to direct sunlight and was achieved in the same manner as illuminant A, except that the tungsten filament was used with two prescribed liquid filters to give a color which matches 4800 degrees Kelvin.

Illuminant C gives a radiation which most nearly matches daylight. Again tungsten filaments were used with the filter solutions arranged so that they would produce a color of approximately 6500 degrees Kelvin. Illuminant C is the only one with which we need to be concerned. Because it is considered to be the most satisfactory from a viewing standpoint, it is the one which has been selected by the NTSC as the reference white for color television work. It is shown in the chromaticity diagram as point C.

With reference to white, one other term which we may encounter and with which we should be familiar is "equal energy white." This is shown on the chromaticity diagram as point E and can be described as a white composed of equal amounts of energy from the three primary colors of red, green, and blue.

Since saturation of color is defined as the degree of freedom from white, the spectrum colors which lie directly on the horseshoe curve can be said to be 100 per cent saturated because they contain zero amount of white. At point E, only white light is present; so it can be said to be zero per cent saturated. Various percentages of saturation fall along a straight line drawn between any point on the spectrum locus and point E. As we move toward point E, the saturation will be decreased; and conversely as we move toward the curve, the saturation will be increased. Thus, we can see that a 100 per cent saturated color is one that has 100 per cent purity or freedom from white and that a desaturated color is a color which contains some amount of white light.

Referring again to the chromaticity diagram in Fig. 1-10, we see that the bottom of the horseshoe curve has been completed with a straight line drawn from purplish-blue to red. Although this line completes the curve, it should not be considered in the same sense as the rest of the horseshoe. The reason for this is that the colors along this line cannot be assigned dominant wavelengths within the limits of the spectrum; therefore, these colors are known as nonspectral colors. They can, however, be expressed as the complements of some of the spectrum colors which fall directly on the horseshoe curve. A line from 500 millimicrons has been extended through white to the straight line, and the point of intersection is labeled 500C; or, in other words, the nonspectral color at this point is the complementary color of the bluish-green of a wavelength of 500 millimicrons. The same thing is true of the line that has been extended from a wavelength of 560 millimicrons; 560C is the complementary color of a yellowish-green with a wavelength of 560 millimicrons.

When primary colors were selected for color television work, it was found that these primaries must of necessity be limited by the color phosphors that were available for the picture tube. Fig. 1-10 shows the location of the actual primaries R, G, and B that are used in color television. These points represent the primaries selected by the NTSC and are the colors red, green, and blue. They define a triangle within the boundaries of the chromaticity diagram; the area within the triangle represents the range of colors that are obtainable when these primaries are used. In the NTSC triangle, red has a wavelength of approximately 610 millimicrons, green is approximately 540 millimicrons, and blue is approximately 470 millimicrons. At first glance, this triangle appears much smaller than the gamut of colors obtainable when ideal primaries are used. If we give Fig. 1-10 a closer inspection, however, we see that the NTSC primaries fall very close to the saturated colors on the chromaticity curve. The red primary, for example, is actually on the curve.

Fig. 1-10 also shows the colors obtainable from modern printing inks. It is apparent that the NTSC color triangle covers a considerably larger area than does the gamut of printing inks. It would seem from this that the colors which can be displayed in color television are entirely adequate.

### SUMMARY

In the foregoing discussion, there are many points which are particularly important toward an understanding of the color television system. It might be well to call the reader's attention to some of these points.

The characteristics of human vision are important in that the eye is the instrument which judges the quality of color reception. Human vision is a remarkable function, but it has certain deficiencies and irregularities which limit its effectiveness. An understanding of these limitations is extremely helpful to anyone engaged in color television work. Examples of these limitations are: the luminosity response of the eye to various colors, intensity and time thresholds, contrast limitations, and the visual-angle requirements. It was also pointed out that certain illusions occur particularly with respect to brightness and saturation changes.

Treatment has been given to the two types of light sources, direct and indirect. In addition, the constituent colors and wavelengths of the light spectrum have been investigated. The attributes of hue, saturation, and brightness were described; and their importance will become increasingly evident as we proceed into the study of the color television system.

The development of the chromaticity diagram was covered in some detail. There were two major reasons for this: (1) the diagram is based upon actual tests of human vision, and this fact lends authority to the data which it presents; and (2) the NTSC triangle which can be put to practical use in servicing work is based to a great extent upon the chromaticity diagram.

Since in the color television system the desired colors are produced by a mixing action, a thorough coverage of color-mixture rules has been presented. These rules are basic, and a knowledge of them will prove helpful in analyzing and adjusting color receivers.

Keeping in mind that an understanding of these important points will contribute much toward efficient color

TV servicing, the reader would do well to test his understanding of them. Perhaps a second reading of the discussion of colorimetry would be in order.

To test further the reader's knowledge of this subject, here are a few questions, the answers to which are presented in this discussion:

1. If a small area of red direct light is placed next to a small area of green direct light, what color is seen by eye?
2. What region of the visible spectrum appears brightest to the eye? Why?
3. What is meant by desaturation?
4. What are the relationships of all colors that lie on a line drawn on the chromaticity diagram from point E to any point on the spectrum locus?
5. What are the three NTSC primaries? What are the three secondary colors, and how are they produced?

C. P. OLIPHANT

### GLOSSARY

<b>BRIGHTNESS.</b> The attribute which makes an area appear to emit more or less light.	properties but which is given brightness by light from some outside source.
<b>CHROMATICITY.</b> Chroma; or the quality, state, or degree of having color.	<b>MILLIMICRON (mμ).</b> The unit used in specifying wavelengths of light energy; 1mμ = 10 <sup>-7</sup> cm.
<b>COMPLEMENTARY COLORS.</b> Designating or pertaining to either of a pair of contrasting colors or their energy stimuli which, when mixed in proper proportions, give white or a neutral color such as gray.	<b>NONSATURATED COLOR.</b> A color that is not pure; one that is mixed with its complementary color or with white.
<b>DIRECT LIGHT.</b> Light from a self-luminous object such as the sun or an incandescent lamp.	<b>PRIMARY COLORS.</b> Any of a set of colors from which all other colors may be regarded as derived; hence, any of a set of stimuli from which all colors may be evoked by mixture.
<b>EQUAL-ENERGY WHITE.</b> The light produced by a source radiating equal energy at all visible wavelengths.	<b>PURITY.</b> Freedom from mixture with white or with any other color.
<b>HUE.</b> The name of a color such as red, yellow, blue, or the like.	<b>SATURATED COLOR.</b> A color that is not mixed with its complementary color or with white.
<b>ILLUMINANT C.</b> The reference white of color television; light which most nearly matches average daylight.	<b>SATURATION.</b> The degree to which white light is absent in a particular color.
<b>INDIRECT LIGHT.</b> Light from an object which does not have self-luminous	<b>SECONDARY COLORS.</b> A color formed by mixing two primary colors in equal or equivalent quantities.



Patent Pending

**LIGHTNING ARRESTER**

JFD MANUFACTURING CO.  
BROOKLYN 4, NEW YORK

**ULTRA LOW LOSS DESIGNED FOR HIGHEST UHF GAIN**

DON'T RUIN your installation with a lightning arrester of high insertion loss. Install the arrester that's an asset instead of a liability to your UHF or VHF installation—the JFD "3-IN-1" with the ultra low loss compensating coil circuit. Thousands of installations prove the "3-IN-1" gives the lowest insertion loss of any arrester in use today. Patented strain-relief lips and patented saw-tooth washers are exclusive JFD extras at no extra cost.

Write for Form 210.

No. AT110 with hardware for wall or window sill.....\$1.50 list  
No. AT110S with UL approved stainless steel mounting strap.....\$1.75 list

U. S. Patent Nos. 2,654,857; D-159,330



**3** For UHF-VHF open wire



**1** For all UHF or VHF tubular twin leads

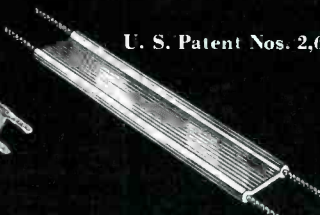

**2** For VHF flat twin leads



**You save more...  
...service better  
with **EMC**  
PRECISION INSTRUMENTS**

The top quality of EMC precision instruments has been proven by years of coast-to-coast tests performed both in the field and on the bench covering every servicing condition.

Exceptionally low prices on these quality instruments are made possible by combining every new engineering advance with EMC large volume production.

Convince yourself... check the features and prices of the two outstanding examples quoted below...

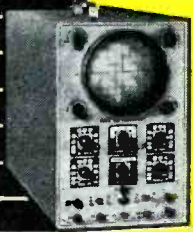

**NEW MODEL 600 OSCILLOSCOPE**

Compare these high quality features with scopes selling up to twice the price of the new model 600.

- Uses new 5 UP1 — 5" scope tube for sharp focusing and good intensity.
- Retrace blanking amplifier to eliminate confusion and give clearer pictures.
- Has built-in 60 cycle phasing control and sweep for TV servicing.
- Uses astigmatism control for better focusing.
- Provision for Z axis input or intensity modulation.
- Synchronization available on positive or negative phase of input voltage or from external source.
- Uses a 2 step compensated attenuator input.
- Has a 2 stage push-pull vertical amplifier with sensitivity of .02 volts per inch.
- Multivibrator sweep from 15 cycles to over 75 kilocycles.
- Direct connections to scope plates available.

New Model 600 (completely wired and tested)..... \$99.50

**MODEL 106  
VACUUM TUBE  
VOLTMETER**

Compare these high quality features with meters selling up to twice the price of Model 106.

- Completely electronic—meter cannot burn out
- Dual triodes balanced bridge circuit
- Zero center adjustment for TV and Fm alignment
- Uses 1% precision resistors for voltage multipliers
- Full scale deflection of 1½ volts for both AC-DC volts
- 1 meg. isolating resistor in probe
- Measures resistance in 5 ranges from .2 ohm to 100C megs.
- Space saving portable Bakelite case — 4¼" x 5¼" x 2⅞"

New Cost-Saving Prices... Lowest on market for wired and kit form.

Model 106, illustrated (Complete with all leads)..... \$35.90

Model 106, in kit form..... 23.90

RF and high voltage accessory probes available.



**EMC**  
ELECTRONIC MEASUREMENTS CORPORATION

280 Lafayette Street, New York 12, New York  
Export Dept., 303 W. 42nd St., N. Y. C.

Write department PF-6 for complete catalog.

**Horizontal AFC Circuits**

(Continued from page 15)

current at a steady value; the magnetic field of L1 collapses and reverses the voltage across L2, driving V2 to cutoff.

During the time the grid was positive, grid current was drawn, resulting in an accumulation of electrons on the grid side of capacitor C8. The oscillatory cycle does not repeat immediately because the charge on C8 is sufficient to hold the grid below cutoff for a lengthy time interval. The current flow during the discharge of C8 decreases exponentially until the voltage drop across R8 and R9 decreases to the cutoff level. It can be seen that the blocking oscillator produces brief bursts of energy at a rate which is governed by the time constant of the components in the grid circuit. In the oscillator circuit shown, the adjustable slug in the plate coil L1 is also effective in changing the frequency of operation.

The output waveform of the oscillator is the desired saw tooth. The forming capacitor C12 is connected between the plate circuit and the cathode of the oscillator, and its

charging cycle begins when the grid cuts off the plate current. The capacitor charges through resistor R12. The values of C12 and R12 are selected so that C12 will charge to a small percentage of the B+ voltage in one cycle of operations. This results in improved linearity. When the tube conducts, the forming capacitor is discharged. This action can best be seen by comparing waveform W7 with the other waveforms in Fig. 8-9. W4 is the waveform present on the grid of the oscillator, and W5 is the plate waveform.

On waveform W4, point 1 indicates the time at which the grid voltage reaches the cutoff level. Plate current starts to flow at this time, and waveform W5 shows that the plate voltage goes down. Point 2 is the time of maximum positive grid voltage (W4) and minimum plate voltage (W5). A series of damped oscillations occur until point 3. R10, which is placed across L1, is effective in damping out these oscillations. The grid is below cutoff, and capacitor C8 begins to discharge. Point 4 is the time at which the grid again reaches the cutoff point, and the cycle begins anew.

The foregoing explanation of the oscillator action and the photographs of the waveforms were all presented with the assumption that the tuned circuit composed of L3, C9, and R11 was not in the circuit or was shorted out. When the short is removed, the tuned circuit is in series with the plate circuit and it is shock excited into oscillation by the rapid changes in the plate current. The values of L3, C9, and R11 are such that the resonant frequency of the combination is slightly higher than the frequency of the blocking oscillator and that the voltage across the coil has the correct amplitude. In this way a sine wave of voltage is superimposed upon the plate supply voltage as well as upon the exponential discharge waveform which is present on the grid. Because of the sine wave, the tube approaches the conduction level more rapidly than before. This makes the oscillator much less susceptible to triggering by random noise pulses. The altered waveforms resulting from this sine wave are shown in Fig. 8-10. Note that the output waveform W7 in Fig. 8-10 is identical to the output waveform W7 in Fig. 8-9, indicating that the addition of L3 has no effect on the generated signal.

The adjustment of the variable core in coil L3 is a service adjustment which makes it possible to adjust the phasing of the sine-wave voltage with regard to the saw-tooth waveform of the oscillator. Normally, this slug is adjusted so that the peak of the sine

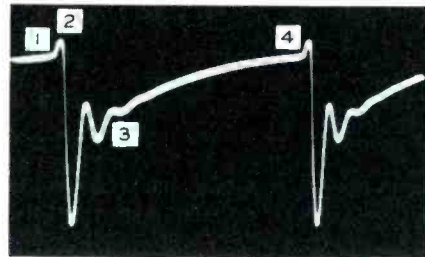

W4—Grid Waveform.

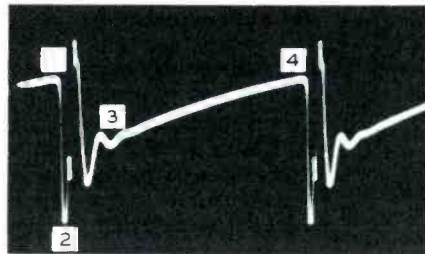

W5—Plate Waveform.

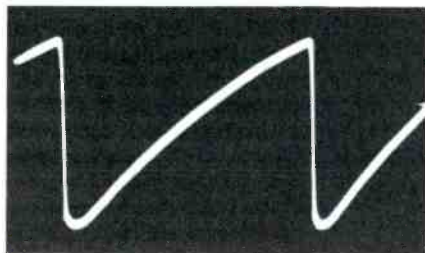

W7—Output Waveform.

**Fig. 8-9. Oscillator Waveforms With L3 Shorted.**

# MORE DEALERS ARE INSTALLING

## CHANNEL MASTER'S CHAMPION THAN ANY OTHER ANTENNA IN TELEVISION HISTORY!

All-channel reception: VHF & UHF



model no.  
325-2

HORIZONTAL POLAR PATTERNS  
Relative Voltage

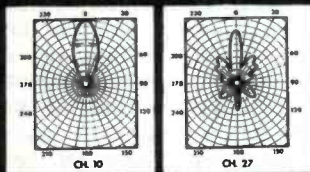

Gain  
(above tuned reference dipole)

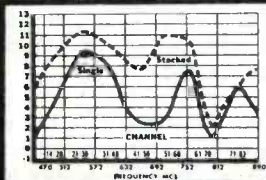
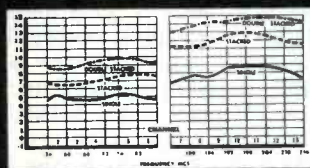

**ONLY THE CHAMPION** enjoys this overwhelming acceptance: over 300,000 already sold!

**ONLY THE CHAMPION** is powered by the unique "Tri-Pole," the triple-powered dipole system that provides fabulous VHF-UHF fringe area performance. 100% aluminum; rugged, exclusive alloy. Installs in a flash!

**ONLY THE CHAMPION** gives you this four-star promotion program:

- ★ **FREE newspaper ads**
- ★ **FREE TV film commercials**
- ★ **FREE colorful display material**
- ★ **FREE consumer literature**

See your Channel Master distributor for full details.

**The antenna America knows best!**

Introduced to millions through the editorial pages of their favorite magazines and newspapers, and on TV.

**DON'T BE MISLED BY "LOOK-ALIKES" . . .  
THERE'S ONLY ONE REAL CHAMPION!**

Model no. 325. Single bay; Model no. 325-4. Four bay; Model no. 325-6, Super Champ



**CHANNEL MASTER CORP.** ELLENVILLE, N. Y.

The World's Largest Manufacturer of Television Antennas

Copyright 1954 Channel Master Corp.

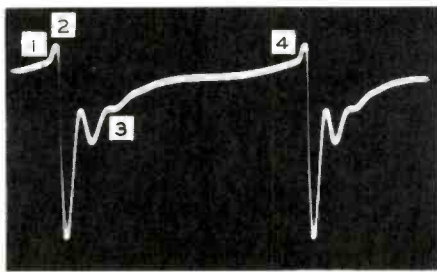

W4—Grid Waveform.

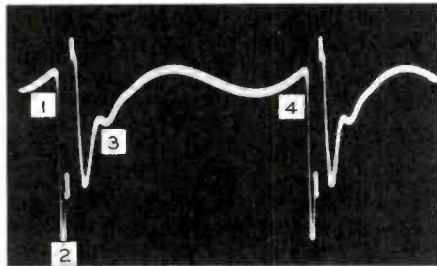

W5—Plate Waveform.

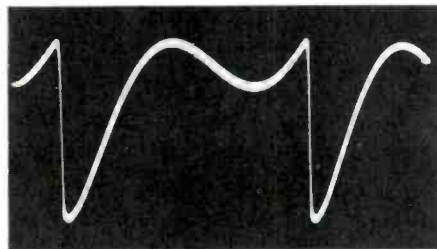

W6—Waveform at Terminal C of Oscillator Transformer.

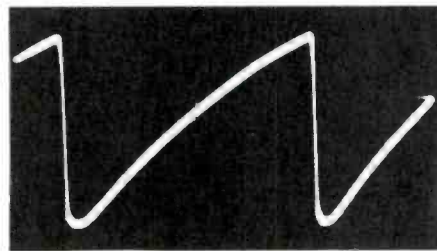

W7—Output Waveform.

**Fig. 8-10. Oscillator Waveforms With Sine-Wave Stabilization.**

wave is equal in amplitude to the peak of the saw tooth as seen on waveform W6 in Fig. 8-10. Fig. 8-11 shows

the waveforms which are obtained with the slug in the two possible maladjusted positions.

In part A of Fig. 8-11, the sine wave has the greater amplitude. This adjustment may cause the oscillator to double-trigger and results in a loss of horizontal sync. Part B of the same figure shows the opposite condition in which the saw tooth has the greater amplitude. An adjustment of this nature loses all the advantages of the sine-wave stabilization, and the oscillator becomes sensitive to noise impulses. When a receiver using the pulse-width control system is operated in an area where extreme noise is present, it is permissible to adjust L3 so that the peak of the sine wave is just slightly above the peak of the saw-tooth waveform. This provides some extra immunity to the noise.

The waveforms shown in Figs. 8-9, 8-10, and 8-11 were taken with the oscillator synchronized to a television signal. The adjustment of L3 must be made while the oscillator is synchronized. If L3 is adjusted with the oscillator in a free-running state, erratic operation will result.

There are many variations of this basic oscillator circuit in use. Several of these variations are shown in Fig. 8-12.

In part A of this figure, capacitor C8 is connected between one end of the grid coil and ground; it performs the same function as in the other circuits. An additional oscillator frequency control is provided in the form of a variable positive voltage in the grid circuit. This control varies the bias on the grid and sets the level at which conduction will occur. The tuned circuit of L3 and C9 is inserted in the cathode circuit instead of the plate circuit, but it performs the same function of superimposing the sine-wave voltage on the grid bias.

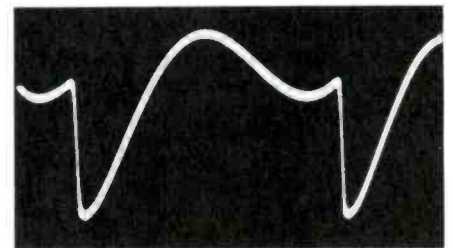

(A) Frequency Too Low.

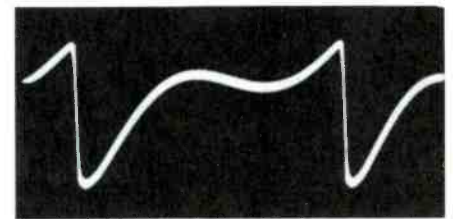

(B) Frequency Too High.

**Fig. 8-11. Waveforms Showing Misadjustment of Variable Core of L3.**

Part B of the same figure shows an oscillator circuit wherein sine-wave stabilization is not used, and the oscillator is controlled by the full voltage developed across C6 and C7 in the cathode circuit of the control tube. Resistor R7 is not used, and the charge on C6 and C7 develops the control voltage across R8. An additional frequency control is provided by the variable capacitor across R8.

The AFC or control tube exercises its control over the oscillator frequency by varying the grid voltage of the oscillator. After one oscillatory cycle has driven the grid to its maximum negative voltage, C8 will discharge to the cutoff level in a definite time interval. An increase in positive voltage on the cathode of the control tube can reduce the required discharge time and thus increase the oscillator frequency. A decrease in positive voltage on the cathode will lower the oscillator frequency by increasing the discharge time. Let us now consider the operation of the AFC tube

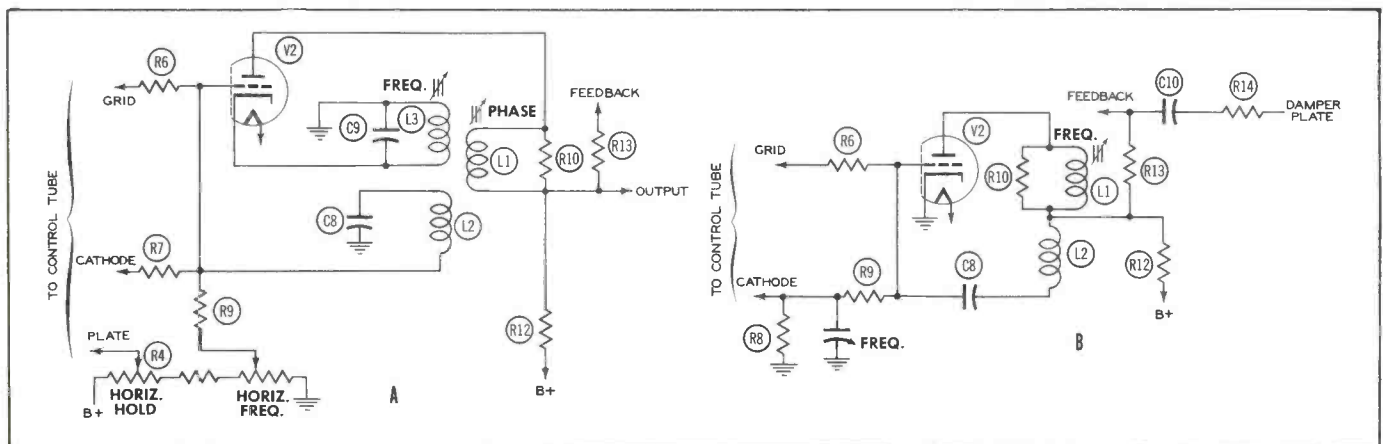

**Fig. 8-12. Two of the Many Variations of the Basic Oscillator Circuit.**

# Two Recognized Masters

Combined in perfect performance for the ultimate in

*high-fidelity  
reproduction*



## ASTATIC MODEL CAC-D-J CRYSTAL TURNOVER CARTRIDGE

THE MOST MASTERFUL performer among single needle, high fidelity crystal cartridges is Astatic's Model CAC-J, a result of collaboration between engineers of Astatic and Columbia Records Inc. How to project these same complete tonal values and absolute purity of reproduction into the design of a double needle, crystal turnover cartridge—without loss of perfection—seemed an insolvable engineering problem. But, pioneering in modern, high fidelity equipment proved as natural for Astatic engineers as their work in developing the first commercially produced crystal cartridges and microphones. The revolutionary new design of the Model CAC-D-J was the result. Combining two complete CAC-J Crystal Cartridge assemblies back to back, on a common plate, this unparalleled turnover unit eliminates interaction between needles and permits ideal output and response characteristics for each record type. Free of the limitations encountered in ordinary cartridge designs, the CAC-D-J has proved to be the most logical partner of the finest in high fidelity amplifiers, speakers and related equipment. When you want the very best, be sure to check this master of crystal cartridges.

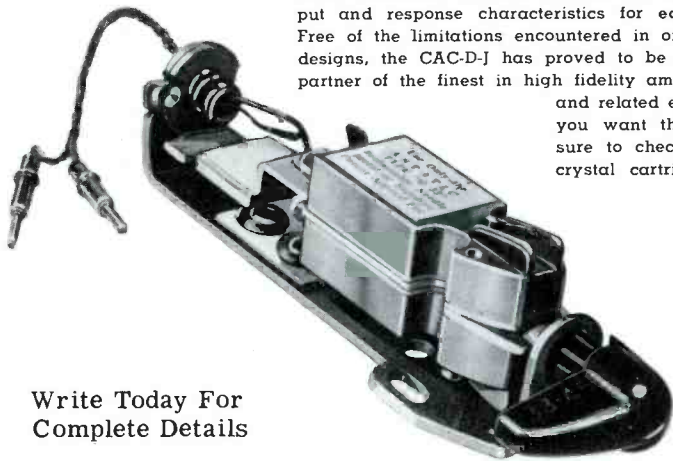
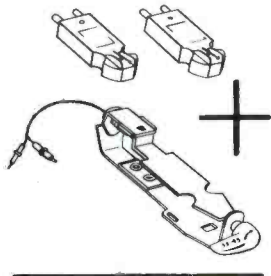

Write Today For  
Complete Details

KNOWN THE WORLD OVER  
FOR HIGHEST QUALITY  
AT LOWEST POSSIBLE COST

**THE**  
*Astatic*  
**CORPORATION**  
ASTATIC  
CONNEAUT, OHIO  
IN CANADA CANADIAN ASTATIC LTD. TORONTO, ONTARIO

**EXPORT**

**REPRESENTATIVE:** 401 Broadway, New York, N. Y. Cable Address: ASTATIC, New York

to see how these voltages are generated.

### AFC or Phase Comparator Tube.

The pulse-width system derives its name from the fact that its operation is based on the variable positioning of the sync pulse upon the peak of a waveform which is derived from the horizontal oscillator; the width of the pulse above the peak will vary with its position. Normal operation of the pulse-width system requires that three separate signals must be combined and impressed on the grid of the AFC tube, V1 on the schematic of Fig. 8-8. These three signals are: a saw-tooth waveform from the horizontal oscillator, a negative-going pulse from the horizontal-sweep output, and a positive-going sync pulse. The AFC tube compares the three signals and derives a DC voltage which then stabilizes the oscillator at the correct frequency and phase. (Actually, some modified circuits of this basis type are used without the pulse from the sweep output, since its only function is to shape the waveform on the grid of the control tube.)

To understand better the operation of the AFC tube, let us divide the input signal into its three component waveforms; but we will consider only two of these at the present time. The waveform W8, shown in Fig. 8-13, illustrates the voltage waveform derived from the output circuit; and waveform W8A is the resulting waveform after integration by resistor R14 and capacitors C10, C2, and C3. (Waveform W8A was obtained under no-signal conditions and with one end of the resistor R13 temporarily disconnected.)

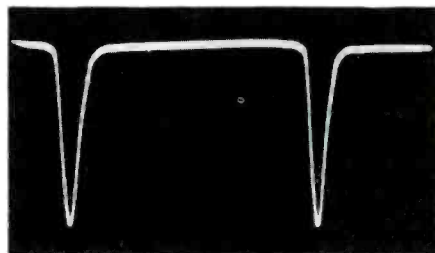

(A) Before Integration.

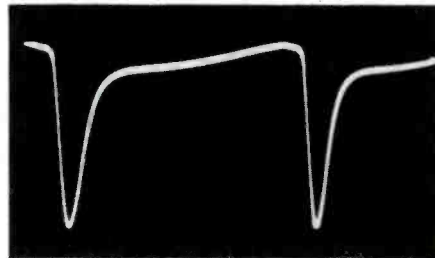

(B) After Integration.

**Fig. 8-13. Feedback Voltages From Horizontal-Output Circuit.**

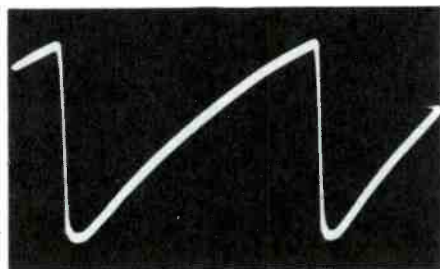

(A) Before Integration.

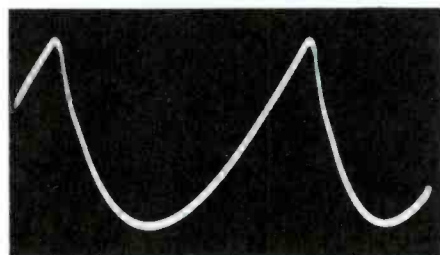

(B) After Integration.

**Fig. 8-14. Feedback Voltage From Oscillator Circuit.**

The photographs in Fig. 8-14 show waveform W7 which is the sawtooth output from the oscillator and waveform W7A which is the same signal after integration through R13, C2, and C3. (Waveform W7A was obtained under no-signal conditions and with one end of capacitor C10 temporarily disconnected.)

Since both W7A and W8A are derived either directly or indirectly from the horizontal oscillator, they will always have the same phase relationship to each other. Thus, they can be added together; the resultant waveform is shown as W2 in Fig. 8-15. (This photograph was obtained under no-signal conditions.) One requirement for this waveform is that the positive peak must have steep leading and trailing edges. The parabolic waveform W7A provides the steep leading edge, whereas the rapid negative-going portion of W8A provides the steep trailing edge.

Since the oscillator V2 is continuously in operation, a high negative voltage is developed on its grid. A portion of this negative voltage is applied to the grid of V1 through

resistor R6, which serves as a filter and an isolation resistor. This voltage is sufficient to bias V1 below cutoff when R4 is properly set. The composite waveform W2 does not have sufficient amplitude to cause plate current to flow in V1, as shown by waveform W2 in Fig. 8-16. When the sync pulse (which is shown as waveform W1 in Fig. 8-16) is added to the waveform W2 and the two have the same frequency and phase, the resulting waveform will appear as waveform W3. It can be seen that the amplitudes will add and V1 will be driven into conduction by the sync pulses. One fact not shown by waveform W3 is that only about one-half of the sync pulse appears on the peak of the waveform W2. The other half is situated on the trailing edge of the peak and is not visible.

Waveform W3 in Fig. 8-16 shows only one of the three possible phase relationships between W1 and W2. It is possible for the oscillator to operate either fast or slow, and it is the function of the AFC tube to compensate for this variation. When the oscillator is synchronized, the sync pulses appearing above the conduction level of V1 have a definite and constant width, as shown in part B of Fig. 8-17. This width will vary if the composite signal W2 were to vary in its phase relationship with W1. If the oscillator tends to run slower than normal, waveform W2 will be displaced to the right in comparison to W1; and that portion of the sync pulse above the conduction level will be wider. This is illustrated in part A of Fig. 8-17. If the oscillator tends to run fast, W2 will be displaced to the left and that portion of the sync pulse above the conduction level will be narrower, as shown in part C of Fig. 8-17. In either case the remainder of the sync pulse which is on the trailing edge of the peak will vary inversely as the width of the pulse on the top of the peak varies.

The width of the pulse which drives V1 into conduction will determine the length of time for which V1 will conduct. The wider pulse will cause conduction for a longer interval than will the narrower pulse. It is

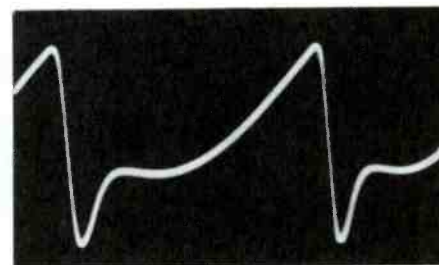
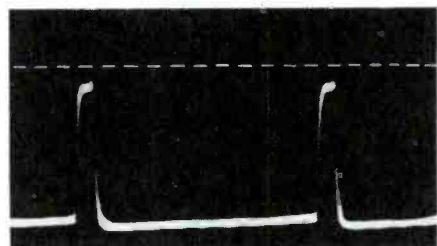

**Fig. 8-15. Composite Waveform Composed of W7A and W8A.**

this time of conduction of V1 which determines the amount and direction of the control exerted on the oscillator.

The plate current of V1 will charge capacitors C6 and C7 more or less, depending upon the length of time that V1 conducts. Resistors R7 and R8 form a voltage divider across C6 and C7; the voltage across the capacitors will be divided between the two resistors. Conduction of V1 produces a positive voltage which is fed to R8. The oscillator grid voltage, which is negative, is also fed to R8. The resultant voltage will affect the oscillator frequency. The positive voltage will change in value as the conduction of V1 increases or decreases because of the variation in the pulse width on the grid. When the oscillator is synchronized and in proper phase relationship, the voltage across R8 will be at its normal value. As before, if the oscillator were running slow, the pulse would be wide; V1 would conduct for a longer interval; and the control voltage would tend to go positive or less negative. A reduction in the negative grid voltage of the oscillator would result, and the oscillator frequency would increase. If the oscillator were already running fast, the foregoing sequence of events would be reversed, and the oscillator frequency would decrease.

The variable resistor R4 in the plate circuit of V1 is labeled the "Horizontal Hold Control." It provides a measure of control over the oscillator frequency because it can be adjusted to set the cutoff point of V1 and can thus determine the level to which C6 and C7 will charge during the conduction time of V1. Indirectly then, this control varies the range



(A) Sync Pulse.

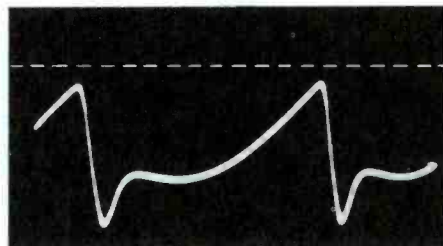

(B) Composite Waveform of W7A and W8A.

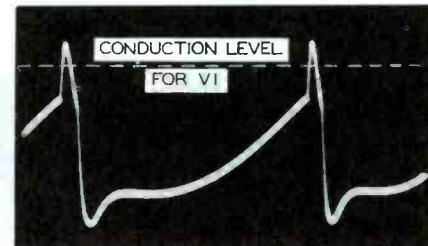

(C) Combination of Sync Pulse and Composite Waveform.

**Fig. 8-16. Signals Present on the Grid of the AFC Tube.**

INSURE CUSTOMER SATISFACTION . . .

**OHMITE®**



*Little Devil®*  
**COMPOSITION  
RESISTORS**

Provide an  
**EXTRA MARGIN  
OF SAFETY**

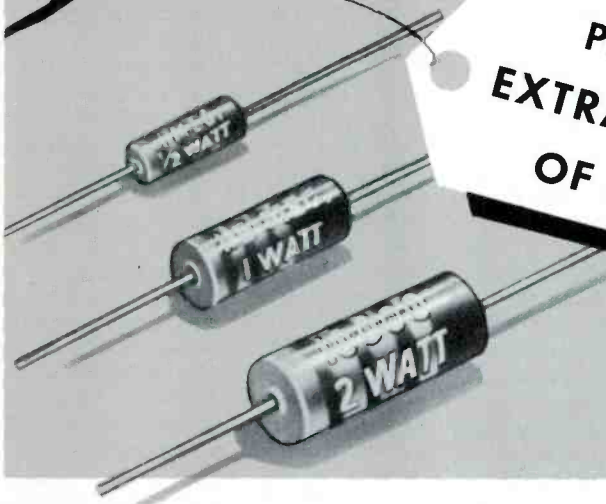

● You can eliminate "call-backs" and insure customer satisfaction by standardizing on Ohmite "Little Devil" composition resistors. These tiny units provide an *extra margin of safety* on your repair jobs. For example, they are rated at 70C instead of the usual 40C . . . and they meet all test requirements of MIL-R-11A, including salt water immersion and high humidity tests without wax impregnation. Ohmite "Little Devil" resistors are available in 1/2, 1, and 2-watt sizes ( $\pm 5\%$  or  $\pm 10\%$  tolerance) in all RETMA values. Order from your distributor, today.

Other Dependable  
OHMITE Products

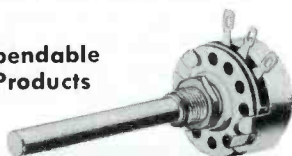

Type AB Noise-Free Potentiometers



BROWN DEVIL Wire-Wound Resistors

Be Right with  
**OHMITE®**

**DEPENDABLE RESISTANCE UNITS**



Write for  
Stock  
Catalog

OHMITE MANUFACTURING CO.  
3644 Howard Street, Skokie, Illinois  
(Suburb of Chicago)

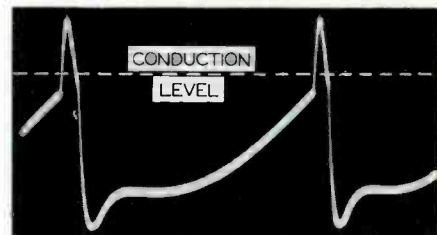

(A) Oscillator Slower Than Normal.

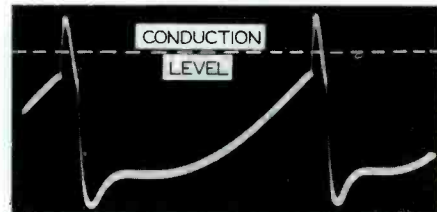

(B) Oscillator in Phase.

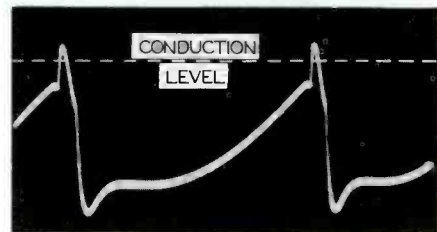

(C) Oscillator Faster Than Normal.

Fig. 8-17. AFC Grid Waveforms Showing Variations as Oscillator Phase Is Changed.

over which the control voltage that is developed across R8 will vary.

**Sync-Pulse Source.**

The pulse-width system, unlike the phase-detector system, requires only one polarity of the sync pulse; and therefore a sync phase-inverter stage is unnecessary. However, the sync-pulse signal for the pulse-width system must have a constant amplitude, and one or more sync-limiter stages are necessary. The positive sync pulse which is applied to the circuit chosen for illustration is taken from the plate circuit of a sync-amplifier stage.

**Trouble Shooting.**

This type of AFC circuit is extremely critical with regard to component values; hence, replacements should be carefully selected and particular attention should be given to temperature coefficients and tolerance ratings as well as values. Components most susceptible to failure include capacitors C1, C5, C8, C10, C12, and resistors R7, R8, R9, and R14. Capacitors C6 and C7 in the cathode circuit of V1 occasionally suffer a loss of capacitance, and this loss is usually evidenced by an appearance of jittering in the picture or unstable synchronization.

William E. Burke

# TV Colormath

(Continued from page 19)

equations 6 and 7 for amplitude values.) Note that the vector sum has a value of 0.877 for R - Y. The I and Q vectors shown in Fig. 8A are drawn along their respective phase angles.

For the B - Y component (Fig. 8A, section 2) the I vector goes negative by -0.27 (B - Y), while the Q vector is 0.41 (B - Y). The vector sum is 0.493 (B - Y).

Fig. 8B, section 3, shows the total as specified by FCC standards. Note that I and Q are in quadrature and that the color-difference components are also in quadrature. The R - Y and B - Y components have a simple 90- and 180-degree phase relationship with the reference color sync burst. "Narrow-band" color receivers utilize this arrangement by directly demodulating the color-difference components with comparatively simple circuits. "Wide-band" receivers utilizing full I bandwidth are more complicated, not so much because of the phase relationships but because of the more elaborate matrixer necessary and the facilities used to modify the effect of crosstalk caused by the I-signal vestigial sideband.

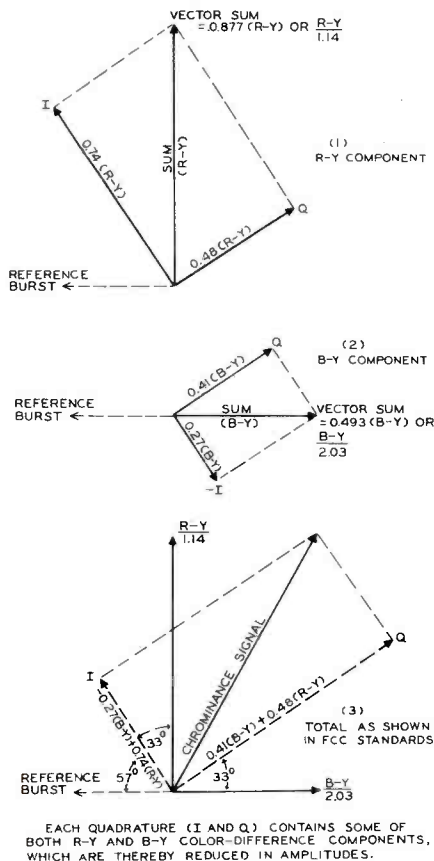

**Fig. 8B. Relationships of the R-Y and B-Y Vectors With Those of the I and Q Vectors.**

TABLE I

COLOR SYSTEM RELATIONSHIPS FOR PRIMARIES AND COMPLEMENTS

Transmitted Color	E <sub>G</sub>	E <sub>R</sub>	E <sub>B</sub>	E <sub>Y</sub>	G - Y	R - Y	B - Y	Q	I
Green	1	0	0	0.59	0.41	-0.59	-0.59	-0.525	-0.28
Yellow	1	1	0	0.89	0.11	0.11	-0.89	-0.31	+0.32
Red	0	1	0	0.3	-0.3	0.7	-0.3	+0.21	+0.60
Magenta	0	1	1	0.41	-0.41	0.59	0.59	+0.525	+0.28
Blue	0	0	1	0.11	-0.11	-0.11	0.89	+0.31	-0.32
Cyan	1	0	1	0.7	0.3	-0.7	0.3	-0.21	-0.60

E<sub>G</sub>, E<sub>R</sub>, and E<sub>B</sub> are the green, red, and blue voltages, respectively, of the camera channel. Thus, yellow equals green and red minus blue, magenta equals red and blue minus green, and cyan equals green and blue minus red.

The vectors shown in Fig. 8B indicate the relationships of only the chrominance information in terms of I and Q, as well as R - Y and B - Y. This relationship is not fixed, as witnessed by the fact pointed out previously that on television white, the sum of I and Q is zero, and the sum of R - Y and B - Y is zero. The vectors then collapse, and the chrominance signal is zero. The quadrature system may express any phase angle from 0 to 360 degrees.

The phase angles of the I-Q transmission primaries were chosen so that the I (wide-band) axis lies along the orange-cyan line of a chromaticity diagram.

Assume that the camera is scanning a highly saturated red surface at maximum brightness (Fig. 8C, section 1). We may trace the action as was done previously for white. The output of the gamma amplifiers will be one volt for red, zero for blue and green. (See Table I.) The luminance channel then has just 0.3 volt, the luminance level of the red signal. As shown by Fig. 8C, section 1, this results in an R - Y chrominance primary of 0.7 and a B - Y chrominance primary of -0.3. When put into transmission primaries, as previously discussed, R - Y becomes 0.614 at 90 degrees and B - Y becomes -0.148 (see Fig. 8C, section 2).

Note that the positive B - Y axis is taken as the reference of zero degrees; the color sync burst is designated as + 180 degrees. The vector sum of the red primary (Fig. 8C, section 3) is therefore 0.632 at 104 degrees. This amplitude is for maximum saturation. Mixture with white would simply reduce this amplitude. Contamination with any other hue would change the phase. Phase-angle accuracy must be held within ± 10 degrees.

Fig. 8D shows the formation of the red vector in terms of actual I-Q transmission primaries. Note that the I-Q matrixer at the transmission end proportions the R - Y and B - Y color-difference signals in amplitude. Then the I and Q modulators, which are driven by carriers in quadrature (Fig. 8A), contain the I and Q chrominance sidebands in quadrature.

Fig. 8E shows that simple amplitude relationships of the quadrature system may express any angle from zero to 360 degrees.

If we carry out the foregoing computation for all six major colors

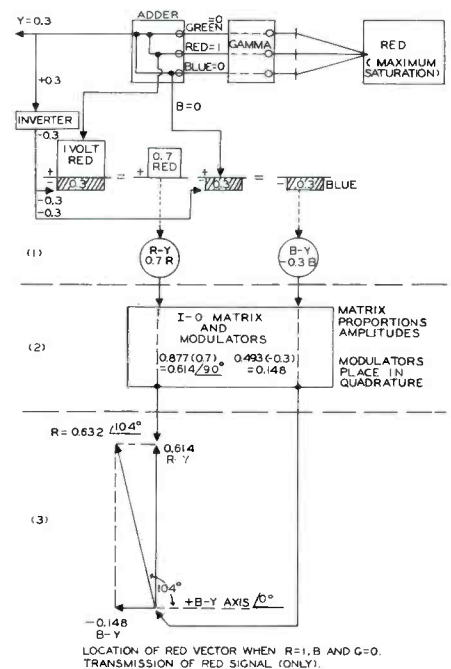

**Fig. 8C. Location of Red Vector for Transmission of Red Signal at Maximum Saturation.**

The *FIRST STEP* in

**HIGH  
FIDELITY**

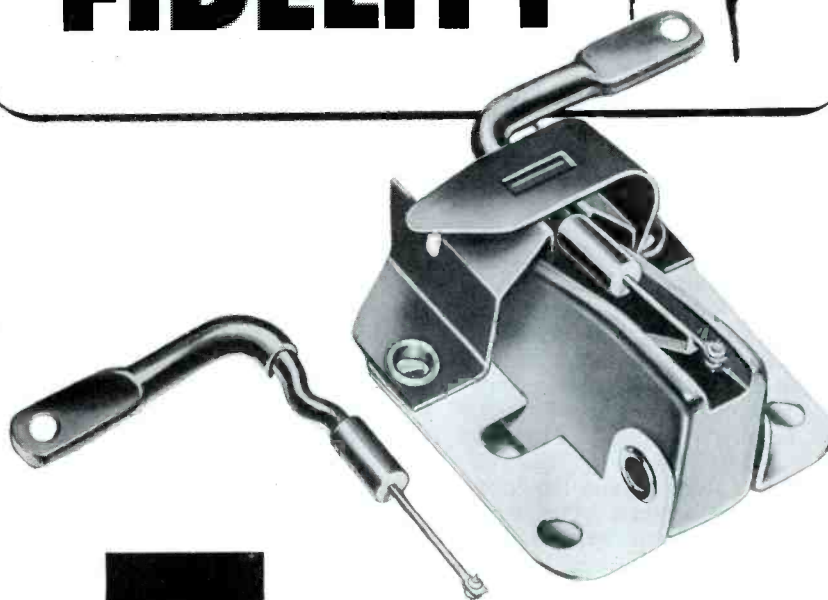

# TITONE

## CERAMIC CARTRIDGE

There is no wiser investment a phonograph owner can make than a TITONE ceramic cartridge.

Costing no more than ordinary "replacement" cartridges, TITONE gives a world of difference in results — an entirely new experience in true high-fidelity sound, no matter what the make of phonograph.

And only *two models* will replace most present-day installations!

**No other cartridge gives all these features!**

No preamplifier or equalizer needed • Unaffected by moisture or temperature • Wide frequency range • Outstanding response • High sensitivity • Low distortion • High compliance • No hum pickup • Superior tracking ability • Wide adaptability • Proper groove fit • Only needle rotates • Simple to replace

( Used by America's foremost manufacturers of high-fidelity phonographs, TITONE is an original discovery and development of the Sonotone laboratories. Literature available. )

ELECTRONIC APPLICATIONS DIVISION

**SONOTONE CORPORATION**

Elmsford, New York

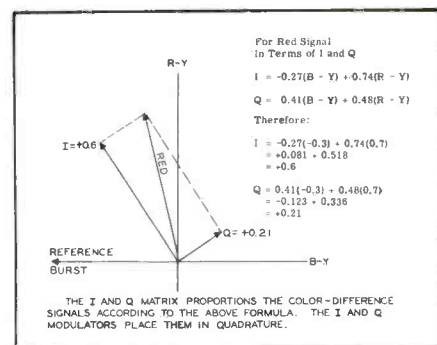

Fig. 8D. Formation of Red Vector in Terms of I and Q Transmission Primaries.

(three primaries and their complementary colors), we arrive at the following values:

COLOR	PHASE (θ)
B - Y	0°
Magenta	61°
R - Y	90°
Red	104°
Yellow	167°
Reference Burst	180°
Green	241°
Cyan	284°
Blue	347°

These relationships for maximum saturation conditions or maximum values of vector amplitudes are illustrated in polar form by Fig. 8F. Note that these amplitudes explain why the red and blue chrominance signals exceed luminance levels and extend into the sync region and why yellow extends beyond carrier cutoff. Also note that cyan is in quadrant 4 directly opposite red in quadrant 2; yellow is directly opposite blue; magenta is directly opposite green; and that these complementary colors have the same amplitude as the primaries opposite them. The amplitudes represented by Fig. 8F must be held within ±20 per cent for color fidelity. Further deviation results in both luminance and chrominance errors, since the ratio of the color carrier to the luminance carrier affects saturation information in colored areas.

We may place the respective color axes on the chromaticity diagram of Fig. 8G, if we assume an over-all linear system in which gamma = 1. Departure from linear gamma would be shown by curved lines. Note first the red-cyan axis. As the red vector collapses into illuminant C or white, the minus-red axis continues to cyan. Observe from Fig. 8F that cyan is



actually the vector sum of the green and blue components. This could be proved by completing the parallelogram, as was done in Fig. 8C. Thus, when the beam for the red phosphor is cut off and when the blue and green phosphors are excited by the amplitudes of Fig. 8F, cyan results. Follow the green-magenta axis of Fig. 8G, and note that as green goes through white, the minus-green axis projects to magenta along the red-blue axis. See also from Fig. 8F that magenta is actually the vector sum of red and blue. In this case, the green phosphor is not excited (minus green); and excitation of red and blue dots produces magenta. Yellow is the vector sum of red plus green minus blue. If the red, green, and blue vectors are added, the vectors collapse and the vector sum = 0; and white or illuminant C is contributed entirely by the luminance channel.

We realize from Fig. 8B that the I and Q transmission primaries are quadrature components containing the foregoing chrominance relationships. Fig. 8H places I and Q on their respective axes on the color triangle. The I axis (with Q = 0) is able to define colors along the orange-cyan line; the Q (with I = 0) is able to define colors along the yellow-green line to purple. The wide-band information (I signal) was chosen along this axis after careful field testing revealed the advantage in defining smaller color elements in this region. The yellow-green to purple color areas require less definition to produce satisfactory color areas. Frequencies up to 500 kc allow a definition of approximately 50 lines, and frequencies up to 1.3 mc (the I channel)

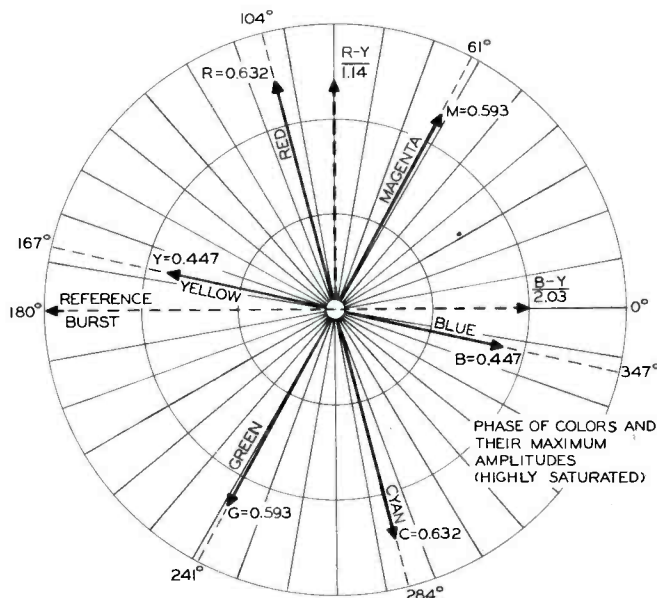

Fig. 8F. Polar Diagram Showing Phase and Maximum Amplitudes of Highly Saturated Colors.

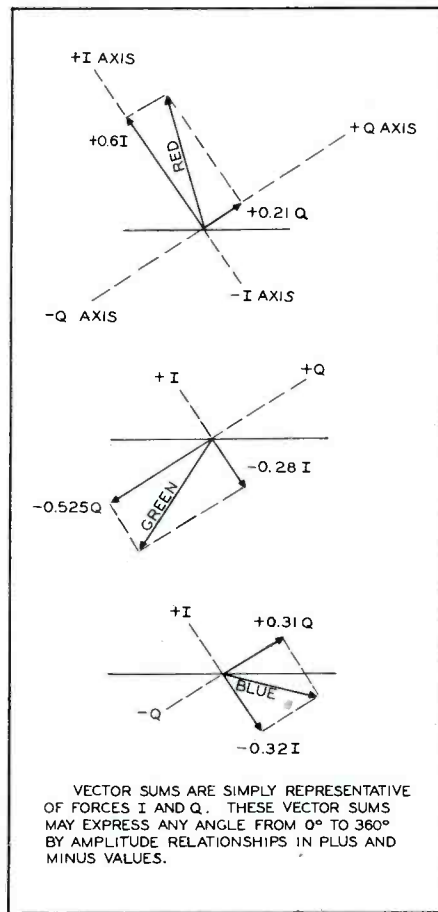

Fig. 8E. Location of Primary-Color Vectors Resulting From I and Q Forces.

allow approximately 140 lines resolution.

For convenience and for future reference, Table I tabulates color-system relationships for given hues.

Thus, we have a three-primary full-color system capable of four general sets of conditions:

1. The luminance voltage  $E_Y$  carries the fine detail of the smallest picture elements in monochrome.
2. If only  $E_Y$  and  $E_I$  are active, we have a two-primary orange-cyan system.
3. If only  $E_Y$  and  $E_Q$  are active, we have a two-primary yellow-green to purple system.
4. For  $E_Y$ ,  $E_I$ , and  $E_Q$ , we have the three-primary full-color system.

This arrangement is based upon the fact that chrominance information of very small areas is not distinguishable to the eye. The reader may prove this to himself by taking a large colored sheet of paper and cutting off a tiny portion. It will be noted that the hue is far less distinguishable. This holds more true for the yellow-purple gamut of colors than for the orange-cyan gamut, and it is the reason for allowing greater bandwidth or higher chrominance definition in the orange-cyan region. The luminance channel (4.18 mc) is capable of resolving elements of slightly less than 0.125 microseconds or 420 lines; thus, the main definition in color is carried by the Y channel in monochrome.

The balanced modulators indicated in Fig. 8A suppress the actual color carrier and radiate only the sidebands. The function is illustrated in Fig. 8I. Note from Fig. 8A that the I and Q carriers are the same

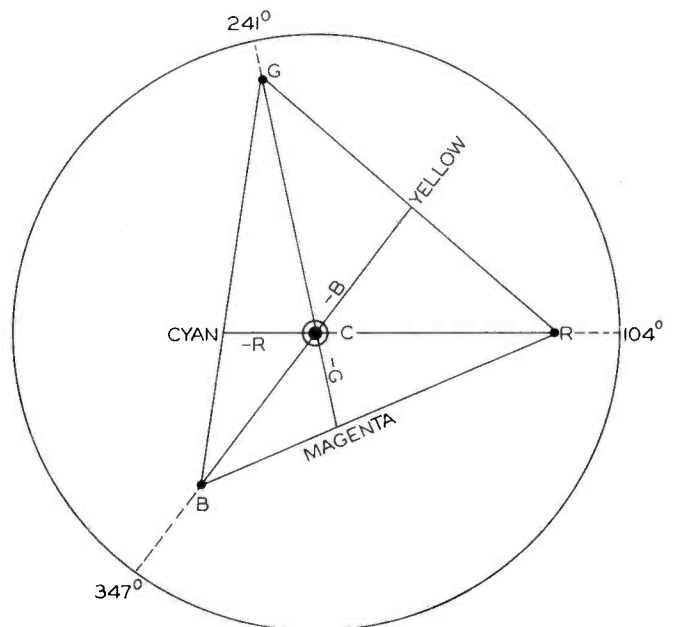

Fig. 8G. Location of Axes of Primary and Complementary Colors.

# ATR INTRODUCES



## The World's Finest Communication VIBRATORS

featuring:

- CERAMIC STACK SPACERS
- 1/4" DIAMETER POWER CONTACTS
- DRIVER-TYPE COIL CONSTRUCTION
- SPECIAL REED HINGE and WIRING
- POWER CAPABILITY UP TO 15 AMPERES

A COMPLETE LINE OF REPLACEMENT

### ATR VIBRATORS

FOR AUTOMOTIVE, HOUSEHOLD and  
TWO-WAY COMMUNICATION SETS

ATR VIBRATORS are proven units of the highest quality, engineered to perfection. They are backed by more than 23 years of vibrator design and research, development and manufacturing.

ATR pioneered in the vibrator field.



**FREE** - Just off the Press!  
1954 ATR VIBRATOR  
MASTER MANUAL

See your jobber or write factory today  
for complete information



**AMERICAN TELEVISION & RADIO Co.**

Quality Products Since 1931

SAINT PAUL 1, MINNESOTA - U. S. A.

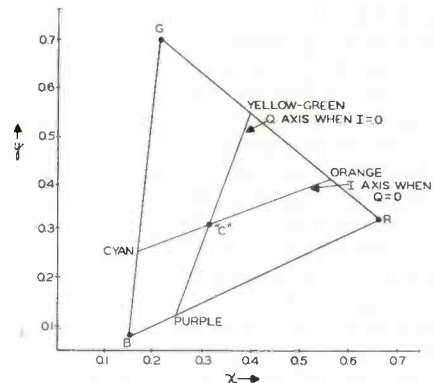

WITH BOTH I AND Q ACTIVE, THE ENTIRE GAMUT OF THE COLOR TRIANGLE MAY BE COVERED.

**Fig. 8H. Location of I and Q Axes on NTSC Triangle.**

frequency as the subcarrier sync burst, but they are in quadrature or 90 degrees apart in phase. From Fig. 8I, it is noted that the carriers, because they are introduced in the method indicated, cancel themselves in the push-pull output. When no chrominance video modulation is introduced, no sidebands result. With chrominance modulation, sidebands occur in the output. Actually, we have amplitude-modulated sidebands that are 90 degrees apart in phase. The receiver is so designed that it can separate the two pieces of information. From Fig. 8E, we know that the amplitudes will depend upon the degree of saturation of the instantaneous scanned point of color and that the phase angle relative to the sync burst is determined by the hue.

In the receiver, the sync burst is used to drive a local carrier oscillator that will therefore be in phase with the sync burst. Then by using synchronous demodulators properly phased from this local carrier, the two distinct bits of information from I and Q chrominance are utilized.

### Luminance and Chrominance Band Sharing

The word compatibility implies that conventional monochrome receivers already existing should be able to reproduce a color telecast in black and white. This immediately fixes a bandwidth for colorcasting at no more than the established 6-mc per television channel; therefore, the addition of the color information must be by a method that will not add to the required bandwidth.

The pickup tube in a monochrome camera is scanned at the line frequency of 15,750 cps. When the scanning beam snaps across the target at this frequency, the beam is changed in amplitude in accordance with the light-pattern charges of the focused image. The resultant rate or frequency of voltage change will al-

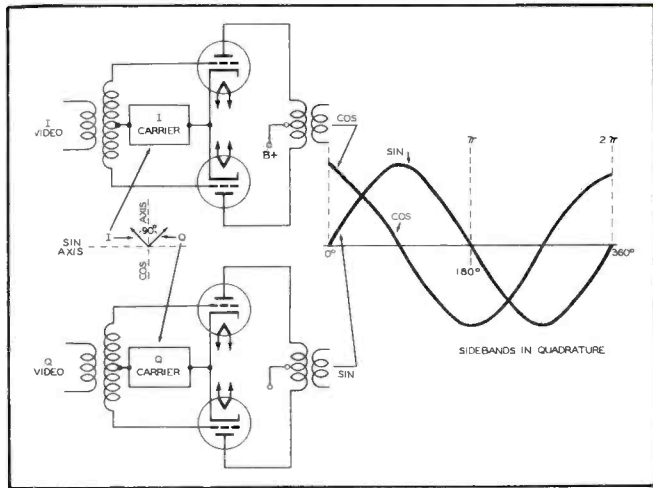
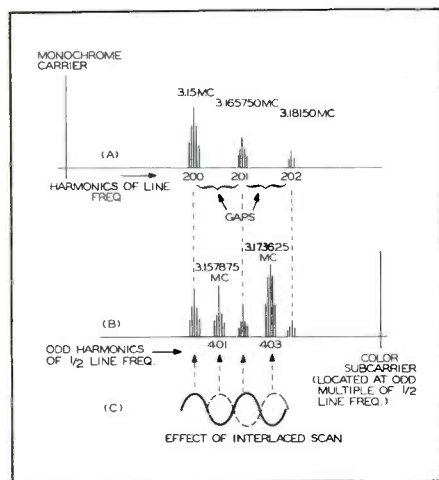

**Fig. 81. Balanced Modulators for I and Q Sideband Generation.**

ways be some multiple of the initial scanning rate of 15,750 cps. Therefore, the major signal components lie at some integral multiple of the line-scanning rate.

This is basically illustrated by fig. 9A, where only three of the harmonics and their frequencies are shown. These clusters of signal information decrease in amplitude as they get farther from the video carrier frequency for any given fine detail being transmitted. Gaps formed between these signal components contain no great amount of information at all.

These gaps occur at odd multiples of one-half the line frequency. Thus, if we generate a carrier at some odd multiple of one-half the line frequency, the subcarrier sidebands will lie in the gaps formed by harmonics of the line frequency. (See Fig. 9B.) This is one form of multiplexing used in certain communication systems, and it is termed "interleaving" in color TV systems. The color subcarrier is placed high in



**Fig. 9. (A) Energy Bursts at Harmonics of Horizontal Line Frequency. (B) Odd Harmonics of One-Half Horizontal Line Frequency. (C) Effect of Interlaced Scan.**

the band, and its maximum amplitude sidebands occur where the monochrome sidebands are small. As the sidebands get farther from the color carrier toward the monochrome carrier, they decrease in amplitude and produce a minimum effect in that region where the monochrome sidebands are larger.

Since there are an odd number of lines (525), this odd multiple of one-half line frequency is also an odd multiple of one-half the frame rate. A frame is composed of two interlaced fields. For each field (Fig. 9C), a point on each line that is made brighter by the color-carrier sidebands lies directly above the point on the succeeding line of the next field which is made darker. When the viewer is back far enough that the lines are not visible, this space integration taking place between lines cancels any brightness variations caused by the presence of the color sidebands in the composite signal. A time integration also occurs, since brightness variations in corresponding lines of successive frames will be 180 degrees out of phase,\* provided that the color sidebands fall exactly at odd multiples of one-half the frame frequencies. Since interference between the two carriers cancels, it is only necessary for the receiver to demodulate each signal with respect to its own carrier.

The foregoing is made clearer if we determine exactly what comprises a picture element. This also affords an insight of the effect of the relative bandwidths used for luminance and chrominance information.

\* Since the color frequency lies between the harmonics of the luminance sidebands and since during a frame it will pass through a whole number plus one-half a cycle (or an odd number of lines), the resulting lines of successive frames are one-half cycle or 180 degrees phased.

It is well-known that the resolution capabilities of any video system are dependent upon the highest frequencies that can be passed without undue attenuation or phase shift. Fig. 9D illustrates the possible resolution of a signal with bandwidth to 4 mc. The actual bandwidth for the Y channel is 4.18 mc; so the resolution should be at least this good in equipment approaching the ideal (insofar as system standards are concerned and not considering other practical limiting factors).

For a 4-mc signal, one cycle occurs in

$$\frac{1}{4 \text{ mc}} = 0.250 \mu \text{ sec.}$$

Consider that on the picture tube grid, a positive voltage swing increases brightness and a negative swing decreases brightness. With interlaced scanning, one cycle is equal to two picture elements. Thus, a frequency of 4 mc allows a picture element of

$$\frac{0.250 \mu \text{ sec}}{2} = 0.125 \mu \text{ sec.}$$

This is to be defined. (See Fig. 9D.)

With a scanning frequency of 15,750 cps, a complete scanned line occurs in

$$\frac{1}{15,750 \text{ cps}} = 63.5 \mu \text{ sec.}$$

Since this includes the H blanking time of 11 microseconds, the active line containing useful picture information is:

$$63.5 - 11 = 52.5 \mu \text{ sec.}$$

If an element is 0.125 microseconds, then 52.5 microseconds are

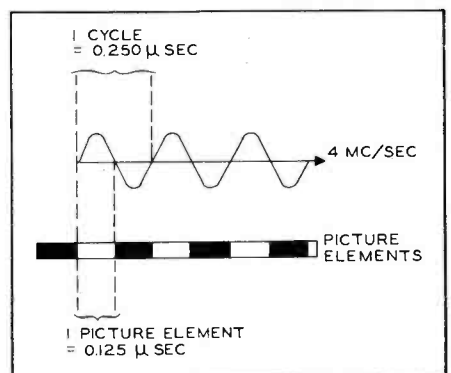

**Fig. 9D. Picture Elements of 4-Megacycle Bandwidth.**

made up of 420 picture elements per line:

$$\frac{52.5}{0.125} = 420.$$

We may define this signal as having a 420-line resolution.

The I channel has a bandwidth of 1.3 mc. This indicates that the highest frequency for maximum resolution is 1.3 mc. One cycle at this frequency occurs in

$$\frac{1}{1.3 \text{ mc}} = 0.76 \mu \text{ sec.}$$

Then one picture element is

$$\frac{0.76 \mu \text{ sec}}{2} = .38 \mu \text{ sec.}$$

Thus, across each active line, the number of picture elements is:

$$\frac{52.5}{0.38} = 140.$$

The Q channel has a bandwidth of 500 kc (0.5 mc). Following the foregoing procedure, we determine that a resolution of about 50 lines is possible.

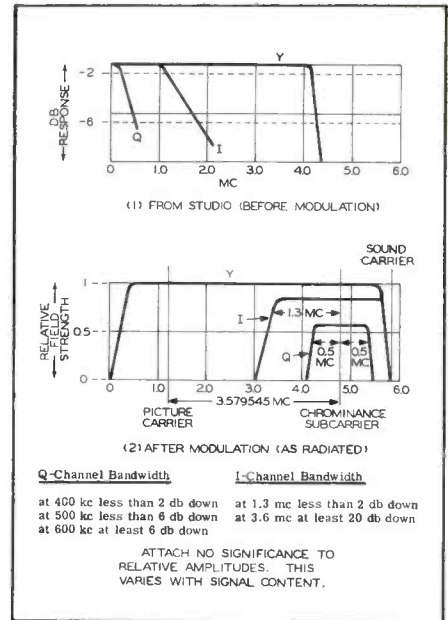

Fig. 9E. I, Q, and Y Signals Before and After Modulation.

This bears out the bandwidth factors previously discussed. The finest picture detail is carried in monochrome by the Y channel. Larger color areas are defined by the Y-channel signals, and still larger colored areas are defined by the Q channel. Narrow-band receivers using only the R - Y and B - Y color-difference signals up to 500 kc have relatively coarse definition of color. Wide-band color receivers utilizing I and Q demodulators have better definition in the orange-cyan region where it is most needed.

The actual frequency proportionment of the composite color system is shown by Fig. 9E. Fig. 9E, section 1, shows the signal as it emanates from the studio output line; and Fig. 9E, section 2, shows the signal in its ideal form as radiated from the transmitter.

The frequency of the chrominance subcarrier is 3.579545 mc. This is an odd multiple of half the line frequency for proper multiplexing or interleaving with the luminance carrier, as pointed out before. The choice of this frequency is such that it is not so high as to be unduly close to the sound carrier nor too close to the upper edge of the video band to restrict the necessary chrominance bandwidth. It is also not so low that conventional monochrome receivers will be visibly affected by chrominance information in nonlinear circuits. At frequencies above 3.5 mc, most conventional receivers attenuate from 10 to 25 or more db.

The chrominance subcarrier frequency was also chosen so that it

when it's a

# QUAM

*Adjust-a-Cone*<sup>®</sup>

## SPEAKER



you can

# SELL IT

and

# FORGET IT!

A FREE copy of the latest Quam Catalog, listing over 100 replacement speakers, is available from your distributor, or from the Quam-Nichols Company.

Quam Speakers just don't come back. Ask any serviceman or distributor who handles them. The patented Adjust-a-Cone suspension and the patented U-shaped coil pot, combined with Quam's advanced production and inspection procedures, are your assurance that every Quam Speaker is a trouble-free speaker.

ask for **QUAM** the quality line for all your speaker needs

**QUAM-NICHOLS COMPANY**  
234 EAST MARQUETTE RD. • CHICAGO 37, ILLINOIS

would result in minimum beat-frequency interference with the sound carrier. To achieve this, it is necessary for the chrominance carrier to be offset from the sound carrier so that the frequency interval is also an odd multiple.

The necessary choice of the chrominance subcarrier frequency has resulted in a slight change in actual line and frame frequencies from those of previous monochrome standards. To make the chrominance carrier frequency an odd multiple of half the line rate, the new line rate becomes 15,734.26 cps. This is a reduction of only 0.1 per cent and is well within the range of existing monochrome-receiver hold controls. The new field rate then is:

$$\frac{15,734.26}{2} = 59.94 \text{ cps.}$$

Transmitters can no longer use line-lock circuits to lock the field rate (which governs all synchronizing signals) to the power-line frequency (60 cps). The frequency of the color subcarrier is generated by a crystal oscillator, and counters are used to obtain a driving signal for the conventional sync generator, as shown by Fig. 8A.

The problem of reducing beat interference between the sound carrier and the chrominance subcarrier has also led to two additional changes in standards. The aural carrier power

is limited to 70 per cent of the peak visual power, and the aural carrier must be maintained at 4.5-mc separation from the picture carrier within  $\pm 1000$  cps.

The color-sync-burst frequency is 3.579545 mc and consists of 8 to 10 cycles at this frequency. Its average value coincides with the blanking level and extends in amplitude above and below this level by about one-half of the sync-pulse amplitude. Extension below blanking level has a tendency to brighten retrace lines. This is minimized by proper reference-black setup at the studio and by retrace blanking circuits in modern receivers.

HAROLD E. ENNES

## Shop Talk

(Continued from page 5)

Sound" we might have the following causes:

1. Aging tubes.
2. Low B+.
3. Defective germanium detector in intercarrier receivers.
4. Misalignment — sound or video IF systems.

If we were to add tally marks to the list, then item No. 1 might have eight such marks after it, item No. 3, three marks, and item No. 4, three marks. (This tabulation was taken from the records of one service organization.) This list would tell you that tubes were the most frequent causes of weak sound; and in the absence of any specific service information, these would be checked first. In this way, we put our past experience to work for us; and if the tabulation has been conscientiously maintained, this procedure will place the odds of finding trouble early in an analysis clearly in our favor. This is, after all, what we want. No service technician has any right to ask for anything more.

Noisy sound is another difficulty which we encountered from time to time, and here is a representative list of the reasons why a set might sound noisy:

1. Defective ratio-detector stabilizing capacitor.
2. Noisy volume control.
3. Intermittent voice-coil connection on speaker.

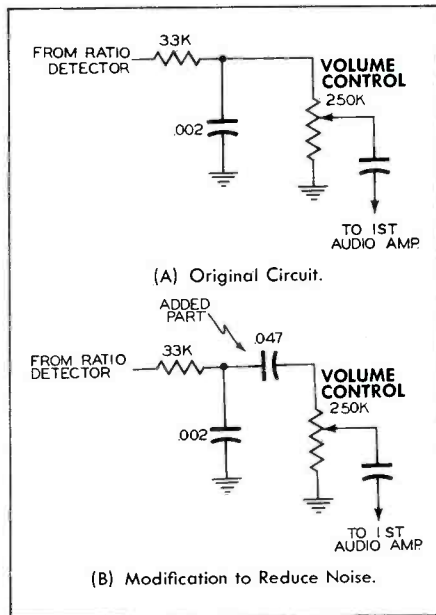

Fig. 1. Addition of .047-mfd Capacitor Eliminated Noise Stemming From the Direct Current Flowing Through the Volume Control.

4. Poor ground connection.
5. Direct current through volume control (poor design).
6. Stabilizing capacitor of ratio detector too low in value. (This is frequently the result of poor design.)
7. Cores loose in IF coils. (This trouble generally causes sharp changes in volume.)

The poor design notations at items Nos. 5 and 6 serve to call your attention either to a specific service note or to the fact that a component may test all right but still be the cause of the symptom. For example,

the circuit shown in Fig. 1A initially appeared on the manufacturer's original schematic and in the set. However, since a DC path existed through the volume-control circuit, direct current flowing in this circuit resulted in noisy volume-control action. By the addition of a .05-mfd capacitor (Fig. 1B), the DC path was broken and the trouble corrected. No component had to be replaced.

A similar situation existed in the case of item No. 6. By placing the words "Poor Design" or "Design Modification," the technician is alerted to the fact that he is dealing with a situation in which no component is defective; so no valuable time would be lost looking for one.

Another listing that we might have with respect to the sound system is "Noisy Sound With Picture Affected." The fact that the noise or other disturbance affected both sound and picture is an important distinction to make and is the reason this wording is shown so prominently in the table listing. Within this category we would find the following causes:

1. Internal arcing in the 500-mmf high-voltage filter capacitor. (There are noise streaks in the picture and a frying noise in the sound.)
2. Arcing in high-voltage system or at the picture tube. (An arcing or a sizzling sound from the set itself is accompanied by a crackling noise from the loudspeaker. The picture contains white or dark streaks or flashes of light.)
3. Circuit oscillating. (The picture fades in and out; the sound motorboats.)

4. Noisy tuner with poor contacts generally. (There is a crackling sound in the speaker, and there are white flashes in the picture. Use Lubriplate on the contact points.)

5. Ringing sound in the speaker; bars in the picture. (Check for a microphonic oscillator tube.)

In this group, both symptoms and causes are noted; and frequently the remedy is given, too. The latter is advisable when a specific remedy will correct the trouble, such as ap-

plying Lubriplate to the contact points of a noisy tuner.

In future columns, an attempt will be made to compile listings of other common defects that arise in television receivers so that service technicians may use these as the start or nucleus for a set of service lists as described in the foregoing discussion.

**Review** Messrs. M. Bettan and A. S. Price of Radio Merchandise Sales, Inc., discuss the problem of

antenna maintenance in an article entitled, "Maintenance of TV Antennas," which appeared in the March 1953 issue of Radio and Television News Magazine. This magazine is published monthly by the Ziff-Davis Publishing Company, 366 Madison Avenue, New York 17, N. Y. Yearly subscription rate is \$4.00 in the United States, its possessions, and Canada.

One of the aspects of television servicing which has received very little attention is servicing of the television antenna. For some reason, when a technician is called in to service a set with apparently poor sensitivity, the antenna is usually the last thing which he inspects. Even then, the inspection is frequently only cursory. He will check the tubes in the set, suspect the alignment, or wonder about aging components; and if the set cannot be brought back to a satisfactory operating level, he will recommend that it be taken to the shop for further work. Once the set is removed from the house, the antenna ceases to be a factor in its operation; and so any loss in antenna efficiency tends, in this way, to be overlooked.

The antenna is undeniably the most vulnerable of all the components in a television receiving system. In its exposed position it is subject to wind, soot, acid fumes (quite common in many cities), corrosion of its supporting structure, and the electrolytic action engendered by the combination of rain plus whatever minute metallic particles happen to exist at the particular locality. The corrosion, the soot, and the electrolysis do their work quietly or imperceptibly and pass unnoticed unless the antenna is inspected at close range. Wind is more dramatic, frequently skewing the structure off to one side, bending an element into some odd position, or in a fit of great violence leveling the array completely. Where the damage is complete, the effect on the receiver is sufficiently forceful to call immediate attention to the cause. These cases are usually corrected quickly. It is the slow, almost motionless day-to-day attrition that escapes attention; and in the long run, it is this deflection that does the most damage to receiver reception.

Inspection of an antenna should be carried out preferably every 12 to 15 months. These figures represent an average, however, and should be modified in the light of your own experience in your particular locality. Antennas situated near the oceans usually require more frequent inspections, whereas those arrays erected in the dry Southwest could go

# NEW INVENTION OUTMODES ALL PRESENT ANTENNAS!

**53 CLAIMS GRANTED IN 5 U.S. PATENTS ON NEW REVOLUTIONARY ANTENNA INVENTION!**

**NEW!**

**SUPER 60**

#2,585,670 #2,609,503 #2,625,655 #2,644,091 #2,661,423 others pending



The 9-position selector switch electronically rotates the antenna in a stationary position.

**COMPLETELY REVOLUTIONARY**

LIST PRICE  
**\$36.75**  
SEE YOUR  
JOBBER

- ★ GUARANTEED TO POSITIVELY OUTPERFORM ALL OTHER ANTENNAS (with or without rotor motors) on ALL UHF, and ALL VHF stations 2 thru 83 from ALL directions.
- ★ GUARANTEED to positively give you the CLEAREST, SHARPEST, most PERFECT GHOST-FREE pictures possible in both COLOR and black-white.

**MONEY BACK GUARANTEED TO RECEIVE ALL CHANNELS 2-83 FROM ALL DIRECTIONS AND POSITIVELY OUTPERFORM ALL OTHER ANTENNAS WITH OR WITHOUT A ROTORMOTOR**

**UP TO 10 TIMES MORE POWERFUL THAN ALL PRESENT CONVENTIONAL ANTENNAS!**

New, revolutionary antenna, while being up to 10 times more powerful than conventional antennas, is still able to receive all television and FM stations from all directions without a rotor motor of any kind. The electronic orientation switch used with a new type transmission line developed specifically for this extra powerful antenna now makes it possible to clearly receive stations heretofore considered out of range. It is now possible to put up just one antenna, use just one transmission line, pay for just one installation and receive the finest possible reception from the stations in and coming to your area regardless of their direction.

*If your Distributor or Dealer can't supply you... Contact us for the name of one who can*

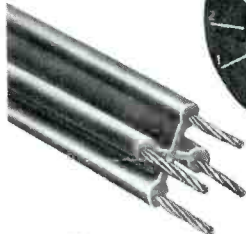

**NEW POLYMICALENE**  
4 CONDUCTOR TRANSMISSION LINE

**THIS IS ALL YOU NEED!**  
The price includes the complete antenna and the 9-position electronic orientation switch. The Air Dielectric Polymicalene Transmission Line is purchased as required for the individual installation.

**ONCE AND FOR ALL SOLVE YOUR ANTENNA PROBLEM**

# ALL CHANNEL ANTENNA CORP.

47-39 49th STREET, WOODSIDE 77, N. Y.

EXETER 2-1336

along for periods of 24 months or more without requiring any special attention. It all depends on the location and the conditions that prevail.

To do a thorough job of antenna inspection and maintenance involves a check of both its structure physically and its performance electrically. Under the former heading would come an inspection of the rigidity and sturdiness of the supporting structure, followed by an examination of the antenna elements themselves. Bolts and guy wires may require tightening, chimney straps may have to be changed, or antenna rods may have to be replaced or bent back into position. If the job of repair is extensive and a relatively simple and inexpensive array is employed, then it will often be cheaper to install a new unit rather than try to return the existing array to a usable condition. This can only be decided by the man doing the work.

When an array has been bent or twisted or merely rotated badly out of position, then a check should be made at the receiver to determine the best angular position of the antenna. A field-strength meter is frequently employed for this purpose, and it would be the sole judge if ghosts did not exist. Unfortunately they do, and the only really conclusive test is by actually viewing the resultant image on the screen.

At this point we might mention that it has been our experience that antenna position (on a horizontal plane) on a roof is not particularly critical in well over 90 per cent of the VHF installations. In other words, you get as good a picture at one point as you do at any other point. Hence, the antenna is usually mounted where it is most convenient — at the chimney, at a vent pipe, or on the parapet walls. Of primary importance is the antenna rotation, and then this is followed in importance by antenna height. More will be discussed on the latter point in a moment.

Once the larger physical components of an antenna and its supporting structure have been attended to, the next items to work on are the smaller hardware (washers, connectors, or soldering lugs), the associated insulators, and the signal take-off points. Broken insulators should be replaced; dirty ones should be wiped clean. Antenna rods should be wiped clear of any grime or soot that may be present. It is not necessary to sand them until the metallic surface once again shows through. Nearly all VHF arrays use aluminum, and the dark coating is a protective

aluminum oxide. So far as reception is concerned, this oxide is in no way harmful; and while removing it may please the customer more, it will not improve reception. Of course, in a short time another coating will take its place.

The various nuts and bolts and other hardware that are used in the antenna are generally made of steel plated with nickel or cadmium. If these parts show rust or corrosion, they are best replaced.

Carefully check the area about the signal take-off lugs. Tighten any loose connections, and replace all corroded parts. Soldered connections for transmission-line conductors are preferable to those in which the wire is simply twisted around the body of the contact screw and then held in place by the pressure of the screw head. The latter have a habit of working loose under the continual tugging of the line against the mast.

After all the hardware around the signal take-off lugs has been thoroughly cleaned or replaced, take an acrylic compound such as Krylon and spray it over the exposed surfaces. This will place a protective plastic coating over these surfaces and afford them more protection from the elements.

The remaining section of an antenna installation still to be examined is the lead-in line. A good grade of line should be usable for at least the normal life of the antenna and hence should not require replacement in the 12 to 15 months specified. There are a number of cheaper lines on the market, and these may require replacement because of drying out or cracking. If such replacement is undertaken, then it is suggested that one of the newer low-loss lines be employed. The attenuation of a flat twin lead rises considerably when the line is wet, either from rain or snow. On the other hand, the tubular twin lead has only a modest attenuation rise under the same conditions. It might also be well to keep in mind the requirements of UHF reception when replacing existing lines, even if no UHF station is currently in operation. There is a good chance one will appear within the next few years.

From time to time the technician will encounter a situation where the original antenna, even when properly rehabilitated, does not provide as much signal as the receiver needs for satisfactory operation. This may

**Built for SERVICE**

**PEP UP  
ANY SET...**

**with an RCA  
SPEAKER**



Look for this  
**GOLD LABEL...**

*Symbol* of superior  
**speaker performance**

RCA Gold Label Speakers have high sensitivity and excellent over-all response. That's why they make any set sound better... and why it's good business to use them exclusively in your replacement work. Sizes range from the miniature 2" x 3" to several 12" types.

Be sure to ask your RCA Distributor for a copy of the new RCA Speaker Catalog, Form No. 3F687. Contains all essential mechanical and electrical specifications on 22 PM and Field-Coil Types.



**RADIO CORPORATION of AMERICA**  
ELECTRONIC COMPONENTS CAMDEN, N.J.



536K Multimeter Kit \$12.90  
Wired \$14.90  
1000 ohms/volt

425K 5" Scope  
Kit \$44.95  
Wired \$79.95

470K 7" Push-Pull Scope  
KIT \$79.95. WIRED \$129.50.

**YOU BUILD**

**EICO**

**KITS  
IN ONE  
EVENING-**

**but they  
last a lifetime...  
and you  
save 50%**

**38 Kits and 42 Instruments —  
the Industry's most complete  
line of MATCHED  
TEST INSTRUMENTS**

**1/4 - million EICO In-**  
struments are now in use  
the world over! That's the  
proof of EICO's leader-  
ship in **Value**.

For latest precision engi-  
neering, finest compo-  
nents, smart professional  
appearance, lifetime per-  
formance and rock-bot-  
tom economy — see and  
**compare the EICO  
line at your Jobber  
before you buy any  
higher-priced equip-  
ment!** You'll agree with  
over 100,000 others that  
only EICO Kits and In-  
struments give you the in-  
dustry's greatest values  
at lowest cost.

Prices 5% higher on West Coast.



221K VTVM Kit \$25.95  
Wired \$39.95



565K Multimeter Kit \$24.95  
Wired \$29.95  
20,000 ohms/volt



377K  
Sine & Square Wave Audio Gen.  
Kit \$31.95. Wired \$49.95



360K Sweep Gen.  
Kit \$34.95. Wired \$49.95



1050K Battery Elm.  
Kit \$29.95. Wired \$38.95

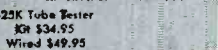

625K Tube Tester  
Kit \$34.95  
Wired \$49.95

Write NOW for FREE latest Catalog PI-6

**EICO**  
Laboratory Precision at lowest cost

©1954

**ELECTRONIC INSTRUMENT CO., Inc.**  
84 Withers Street, Brooklyn 11, N. Y.

be caused by an antenna which was initially inadequate so far as gain was concerned, or it may very well be that signal conditions at that location have been changed. This happens quite frequently in cities and is often the result of the erection of new buildings directly in the path of the signal.

A field-strength meter is one of the best ways of finding out just how much signal the antenna is providing the set. If you find that the antenna pickup is low, the need for a higher gain array is indicated. In weak signal areas, gain and directivity are of prime importance. Other features such as ease of installation, cost, and even bandwidth are frequently of secondary importance. The height of the antenna assumes greater significance when every microvolt of signal must be carefully garnered. In general, the higher the antenna the more signal it will intercept and forward to the receiver; however, signal strength does not increase linearly with height. Rather, it tends to go through a series of what might be termed "ups and downs." That is, the signal will increase for a distance and then start to decrease. After it passes through a low point, it will again commence to increase, the succeeding time reaching a higher peak than it achieved during the previous increase. After this second peak, further increase in height will result in signal reduction again, although the second low point will not be so low as the first minimum level. These ups and downs or variations will exist for a considerable distance up in the air, and it is important to pick a level where a peak rather than a dip exists.

For those who wonder about these signal variations, they are due to the combination of a direct signal from the transmitter together with a ground-reflected signal. The paths followed by these signals differ in length, with the result that at their point of interception they may possess different phases. Where the signals add, we have an increase; where they directly oppose each other, we have a decrease.

As the antenna goes higher and the transmission line gets longer, line attenuation rises and the cost of the supporting structure mounts. These factors will have to be weighed by the service technician and the best compromise chosen.

Milton S. Kiver



**Centralab**  
1600 V.D.C.W. Ceramic Disc  
**BUFFERS**

combine high capacity in minimum  
space with a high safety factor

**Totally unaffected by heat,  
humidity, or vibration**

Talk about ceramic capacitors being made to order for mobile applications—Centralab DD16's fill the bill on every count.

First of all, they're just right for size. They were originally designed for use in electric shavers, so you know they're small. And that's, one reason why they're so widely used as buffers in auto radios.

There are other reasons, also. Though DD16's are small in size, they're big in efficiency. They're 100% inspected and tested at twice rated working voltages. And they maintain high capacity and performance up to + 85° C. operation.

Yet, with all this, Centralab DD16's cost less than ordinary paper or mica capacitors of equal rating (35¢ list).

DD16's are conveniently packaged five per envelope, 25 units per carton. Keep a supply on hand for all your mobile needs. See your Centralab distributor.

Write for free copy of

**Bulletin 42-202**

**to CENTRALAB**

**A Division of**

**Globe-Union Inc.**

**942F E. Keefe Ave.**

**Milwaukee 1, Wisconsin**

**Centralab**



**NEW** Training Course  
**"BASIC RADIO MANUAL"**

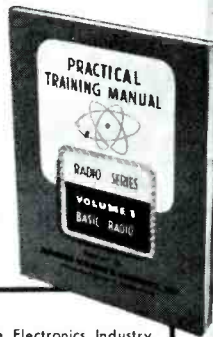

Developed with the cooperation of the Electronics Industry and the help and advice of hundreds of Radio Shop Instructors and educators.

The **BASIC RADIO MANUAL** is a comprehensive 248-page training guide, outlining step-by-step a 36-Lesson Course on Basic Radio, accompanied by a practical Shop Project section demonstrating theories in action (learning by actual doing). The table of contents which follows is the best index to the value of this planned guide for maximum effectiveness in Radio training...

**36-LESSON SECTION:** Basic Electricity • Technical Terms • Circuits & Symbols • Parts Identification • Ohm's Law • Kirchhoff's Voltage Law • Kirchhoff's Current Law • Watt's Law • Cells and Batteries • Magnetism • Electro-Magnetism • Relays • Meters • Meter Construction & Use • Use of Volt-Ohmmeter • Soldering Techniques • Capacitor Construction • Alternating Current • The Capacitor • Resistance-Capacitance • Electro-Magnetic Induction • Inductance, Impedance, etc. • Transformers • Pulsating DC • Vacuum Tube Construction • Vacuum Tube Characteristics • Grid Bias • Voltage & Current Measurements • Power Sources • Rectifiers • AC-DC Power Supply • Voltage Doublers • Transformer Type Power Supplies • Resonance • Oscillators • Principles of Radio Transmission and Reception.

**13-PROJECT SECTION:** Color Code • Circuit Symbols and Technical Terms • Ohm's Law Applications • Kirchhoff's Laws in Application • Soldering Practice • Capacitor Construction & Capacitive Reactance • Inductive Reactance • Vacuum Tube Construction • Tube Characteristics Curves • Crystal Receiver • Construction of AC-DC Power Supply • Construction AC Power Supply • Construction Audio Amplifier.

If you're interested in Radio self-study, or if you instruct in the subject, you'll want the **BASIC RADIO MANUAL**—the complete guide to effective Radio training.

ONLY \$500

**ORDER TODAY!**

**HOWARD W. SAMS & CO., INC.**

**ORDER THIS OUTSTANDING PRACTICAL BOOK FROM YOUR PHOTOFAC T DISTRIBUTOR**

**In the Interest of Quicker Servicing**

(Continued from page 25)

high-impedance path by which signal information can reach the input to the video-amplifier stage without going through the defective video-detector circuit. Since both picture carrier and sound carrier can take this path and since a degree of nonlinearity can exist in the amplification of the video amplifier, a 4.5-mc sound IF signal may be produced.

Another characteristic of this circuit is that in several instances of trouble the picture goes negative. This is caused by the loss of AGC voltage and the resultant overloading of stages ahead of the video detector.

Tests similar to those just described can be applied to other video-detector circuits. We chose a second circuit which employs one-half of a 6AL5 duo-diode, and it is shown in Fig. 2. The various troubles and their associated symptoms are as follows:

**C1 Shorts.** The entire plate voltage of the last video IF stage is placed across L1, and the ensuing current burns out this coil.

**C1 Opens.** The picture and sound are lost.

**L1 Shorts.** The picture and sound are lost.

**L1 Opens.** The picture and sound are lost.

**C2 Shorts.** The picture and sound are lost.

**C2 Opens.** No effect in the picture or sound is noticeable.

**C3 Shorts.** The picture shows evidence of a 4.5-mc pattern resembling interference.

**C3 Opens.** The effect is the same as that of a shorted C3.

**L2 Shorts.** The effect is the same as that of a shorted C3.

**L2 Opens.** The picture and sound are lost.

**L3 Shorts.** No effect in the picture or sound is noticeable.

**L3 Opens.** The picture is washed out; the sound is weak.

**R1 and L3 Both Open.** A loss of picture and sound occurs.

**L4 Shorts.** The picture loses detail because of poor high-frequency response.

**Built for SERVICE**

**Tired of Callbacks?**

Next time use **RCA HV Transformers**

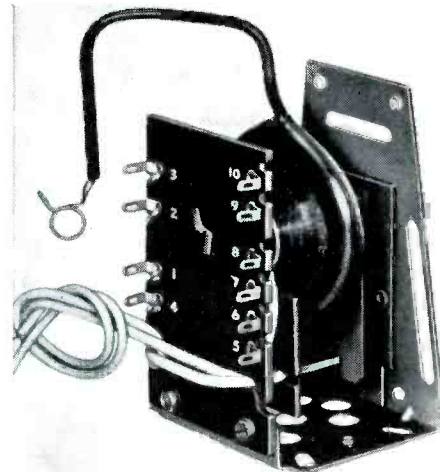

RCA Horizontal-Output and High-Voltage Transformers make life easy for thousands of servicemen... why not you?

Remember... RCA HV Transformers embody the design characteristics originally accepted as standards by the industry. That's why they're best fitted to restore original performance... and keep performing for years. There's a type for virtually all of your replacement needs:—

- 211T1 . . . . . Isolated-secondary type, 57°, 9 kv.
- 211T5 . . . . . Voltage-doubler type, 57°, 13.5 kv.
- 211T3 . . . . . Isolated-secondary type, 57°, 8.75 kv.
- 230T1 . . . . . Autotransformer type, 70°, 18 kv.
- 231T1 . . . . . "Universal," isolated-secondary type, 50° to 70°, 10-15 kv.
- 232T1 . . . . . "Universal," autotransformer type, 50° to 70°, 10-16 kv.
- 235T1 . . . . . Autotransformer type, 90°, 18 kv.

RCA HV Transformers are used as initial equipment by leading TV set manufacturers. You'll find them listed in **Photofacts and Counter Facts**.



**RADIO CORPORATION of AMERICA**  
 ELECTRONIC COMPONENTS CAMDEN, N. J.

# V-M HIGH FIDELITY RECORD CHANGER



Choice of  
More Servicemen  
.. leads in features  
that help you PROFIT

Specify the 935HF for high fidelity record changer conversion. Its many custom type quality features help you gain more profitable hi-fi sales and satisfied customers. Easy installation.

MODEL 935HF \$59.95\*  
MODEL 936HF \$69.95\*  
(with metal pan)

- 1 Exclusive, Precision-Formed Turntable—laminated, balanced to assure constant-speed operation.
- 2 Patented tri-o-matic® Spindle protects records. Records are gently lowered (not dropped) to spindle shelf.
- 3 Exclusive Die Cast Tone Arm of aluminum, is rigid and resonance-free. Balanced for exact adjustment to needle pressure.
- 4 Two Plug-in Tone Arm Heads (less cartridges) are included. Precision-fitted cast aluminum construction.
- 5 Muting Switch for absolute quiet during change cycle.
- 6 Exclusive V-M 45 Spindle permits automatic play of up to 14 large center-hole records.
- 7 Exclusive 4-Pole, 4-COIL Motor that eliminates the source of electronic hum and rumble.

## ADDITIONAL FEATURES

Completely jamproof mechanism. Complete automatic shut-off, plays all three speeds, all size records automatically. Gold base plate, burgundy accessories.

\*Slightly higher in the west  
UL Approved



the Voice of Music

Write for Specifications on V-M Model 935HF

**V-M CORPORATION**  
BENTON HARBOR 7, MICH.

WORLD'S LARGEST MANUFACTURER OF  
PHONOGRAPHS AND RECORD CHANGERS

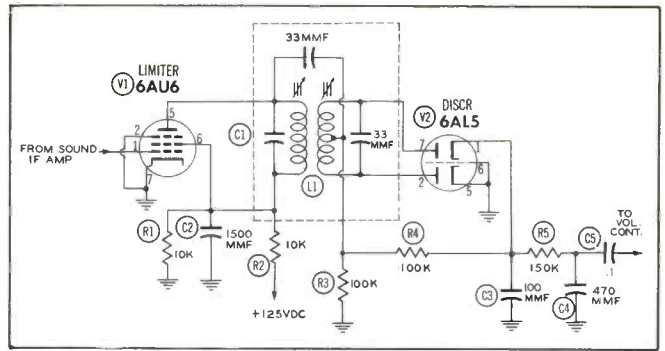

Fig. 3. Typical Sound Discriminator.

L4 Opens. A loss of picture and sound occurs; 60-cycle modulation is visible in the raster.

R2 Opens. The effect is the same as that of an open L4.

V1 Suffers Open Filament. A loss of picture and sound occurs.

The symptoms of component failure in the circuit of Fig. 2 are different in many respects from those in the circuit of Fig. 1. One of the chief reasons for this difference lies in the fact that the AGC voltage is not derived from the video detector. (The receiver uses a keyed AGC system.) As a result of this arrangement, a loss of sound accompanies a loss of picture in many instances of component failure in the detector. Another source of difference in symptoms is the fact that a germanium crystal can pass a reverse current flow to some extent and hence has a tendency to act as a capacitor, whereas the diode tube will not conduct a reverse current and thereby completely blocks an AC signal.

## Sound Discriminators

The sound discriminator is another circuit which does not give trouble too often, but when it does it can be a problem. The trouble that most often occurs in discriminators is that they get out of adjustment because components change in value with age. Changing characteristics in aging tubes also account for some of this trouble. We thought it might be interesting to do the same thing with a discriminator circuit that we did with the video detectors — to take a set using the circuit shown in Fig. 3, put into it various troubles, and see what the results would be. The troubles and their associated symptoms are as follows:

C2 Shorts. The audio is lost; R2 overheats.

C2 Opens. The audio is very weak, and some noise is noticeable.

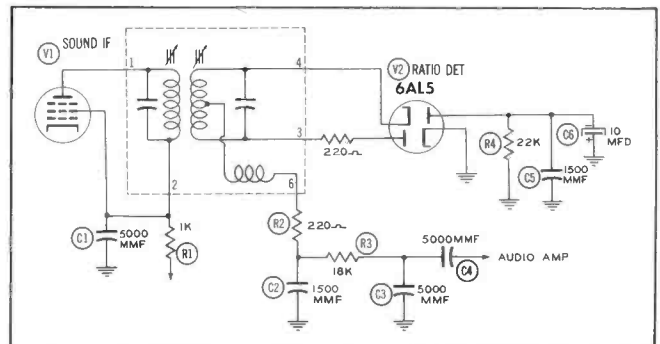

Fig. 4. Typical Ratio Detector.

R1 Opens. The volume increases slightly; noise is present in the sound.

R2 Opens. The audio is lost.

R3 Opens. The audio is garbled beyond recognition and is reduced in level.

R4 Opens. The audio is lost, but noise is very noticeable.

C3 Shorts. The audio is lost.

C3 Opens. The audio shows slight distortion.

R5 Opens. The audio is lost.

C4 Shorts. The audio is lost.

C4 Opens. The audio shows distortion, but it is almost unnoticeable.

C5 Shorts. The effect is not noticeable.

C5 Opens. The audio is lost.

The foregoing tests indicate that a component failure in the discriminator circuit will probably cause a complete loss of audio. This is true particularly of those components in the balanced portion of the circuit.

The components which are most prone to failure in this circuit are the discriminator transformer and the tube. Neither of these is included in the foregoing tests, so it should be stated that their failure will usually result in a complete loss of audio. As previously stated, however, the most likely trouble in discriminator circuits does not arise from component failure but rather from aging components which cause the circuit to drift out of alignment and need adjustments.

### Ratio Detectors

The ratio detector does not differ a great deal from the sound discriminator. For that reason, the problems that arise in the two circuits are very much alike. A study in the following list of troubles and symptoms in the ratio detector shown in Fig. 4 will quickly bear out this statement.

C1 Shorts. The audio is lost; R1 overheats and will probably burn out if the set is left on.

C1 Opens. The audio is lost.

R1 Opens. The audio is lost.

R2 Opens. The audio is lost.

C2 Shorts. The audio is lost.

C2 Opens. The volume level decreases.

R3 Opens. The audio is lost.

C3 Shorts. The audio is lost.

C3 Opens. The audio is lost.

C4 Shorts. No effect is noticeable in the audio output.

C4 Opens. The audio is lost.

R4 Opens. The audio is lost.

C5 Shorts. A large reduction in volume occurs.

C5 Opens. No effect is noticeable in the audio output.

C6 Shorts. The effect is the same as that caused by a shorted C5.

C6 Opens. No effect is noticeable in the audio output.

C5 and C6 Both Open. The audio output contains buzz and distortion.

In the case of failure in either the detector transformer or the tube, the probable result is a loss of audio output. The most likely trouble in ratio detectors is a drift in alignment caused by aging components or tubes.

### Test Socket Adapters

Fig. 5 shows three items which are believed to be definitely in the interest of quicker servicing and therefore should be mentioned in this column. They are socket adapters which provide access to the pins on tubes so that measurements can be taken from the top side of a chassis. The particular units shown in Fig. 5 are produced by the Pomona Electronics Company of Pomona, California. The sizes of the units in the photograph are for 7- and 9-pin miniature tubes and for 8-pin octal tubes. These units are designed to be inserted between the tube and its socket with the least possible effect on the operation of the circuit. In this way voltages can be measured without disrupting the operation of the set and without removing the chassis unnecessarily.

As a good example of the usefulness of these items, let us take the

**Built for SERVICE**

# LOW LOSS!

## Here's why...

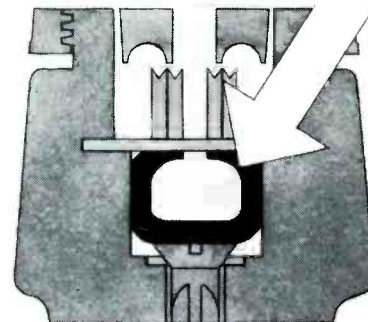

### RCA UHF LIGHTNING ARRESTERS

employ conductive-rubber resistive elements, molded in a special form to present low capacitance across the transmission-line conductors. The contacts are designed and positioned to provide minimum additional shunt capacitance. Result—low loss—only 1 db at 800 Mc!

234A1 Screw Type    235A1 Strap Type

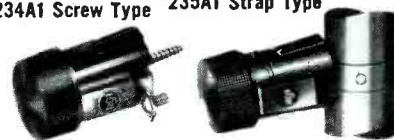

Accommodate Tubular, Oval, Foam and Jacketed UHF Lines. Positive-contact design. Standing-wave ratio approximately 2:1 at 800 Mc. Listed by Underwriter Laboratories, Inc.

### RCA VHF LIGHTNING ARRESTERS

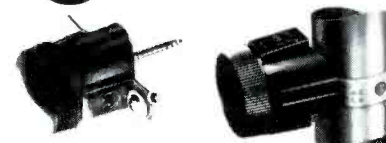

215X1 Screw Type    214X1 Strap Type

Low-loss, positive contact design. Weather resistant . . . continually dissipate static charges . . . do not unbalance line. Listed by Underwriter Laboratories, Inc.

### RCA TV SET COUPLERS

Aperiodic\*, positive-contact design. Permit operation of two or more TV sets from single antenna. No need to cut or splice twin lead.



Type 240A1

\*Improves Voltage-Standing-Wave-Ratio on the line.



**RADIO CORPORATION of AMERICA**  
ELECTRONIC COMPONENTS    CAMDEN, N.J.

**A SIGNAL GENERATOR  
OF QUALITY AND VERSATILITY  
THAT DEMANDS YOUR ATTENTION**

**RCP**

**"WIDE RANGE" SIGNAL GENERATOR**

ONLY \$67<sup>50</sup><sub>net</sub>

**706A**

Equivalent in performance to signal generators priced as high as \$125.00

**COMPARE THE VALUE**—compare the price! You will find that the RCP 706A Signal Generator feature for feature is the finest performer in its class.

**VERSATILITY:** Continuous coverage from 150 KC to 220 Mc. in 8 ranges. Six FUNDAMENTAL ranges cover up through 55 Megacycles.

**ACCURACY:** within 1% of calibration adjustment.

**STABILITY:** and constancy of calibration is assured by special electron-coupled circuit design, permeability adjusted coils and air trimmer capacitors.

**MODULATION:** 400 cycle sine wave audio oscillator with modulation continuously variable from 0% to 80%. Above 80% has no practical application. At this point tremendous distortion occurs in all signal generators. Unmodulated signal is available if desired.

**ATTENUATION:** Ladder type step attenuator consisting of a multiplier and fine attenuator control.

**AUDIO OSCILLATOR:** 400 cycles at 50 ohms output impedance is available for external use—terminals on panel.

Eight scales are clearly calibrated—continuous reading from 150 kilocycles to 220 megacycles. Planetary drive gives vernier tuning with no backlash. Tube complement—6BA6, 6SJ7, 6X4.

A high quality instrument in performance, construction and appearance. Size 16" x 9" x 7". Wt. 14 lbs. Complete with leads. ready for operation on 105-180 volts, 60 cycles.



Write for latest catalog to Dept. RE-5

**RADIO CITY PRODUCTS CO., INC.**



152 W. 25th Street  
New York 1, N.Y.

case of a blooming picture. Most of us know from experience that this trouble can stem from more than one source. One method of isolating the trouble to one or two sections of the receiver is by measuring the B+ voltage. This can be done very simply without removing the chassis. First, place a test socket adapter in the socket of the audio-output tube, and put the tube in the test socket. Then, measure the screen voltage, since this voltage is usually at or near the level of the B+ voltage. This measurement will tell you if the power supply is weak and if it is therefore causing the high voltage to become weak when the beam current in the picture tube is increased. If the B+

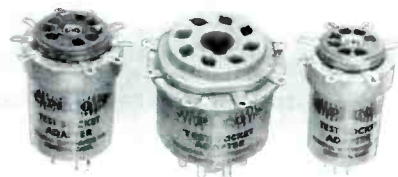

Fig. 5. Test Socket Adapters.

voltage is up to normal, however, you can concentrate your attention on the horizontal-output or high-voltage stages. The horizontal-output tube, the high-voltage rectifier, the damper, and the picture tube should be checked in that order.

The primary demand for the test socket adapters on the work bench is in the troubleshooting of tuners, because it is difficult to check operating voltages in most tuners without completely disassembling them and thereby disturbing their operation. Another bench use for these test socket adapters is that of measuring voltages on sockets which are so hidden by adjacent parts that it is almost impossible to get at the base lugs without tearing the set apart. For instance, some sets have deep chassis with wide terminal boards hiding the tube base connections.

Henry A. Carter

**CORRECTION**

In the installation procedure for the ELIM-A-TRACE unit described on page 85 of the May 1954 issue of the PF INDEX, step 2 should read as follows:

2. Remove the picture-tube socket.

We made a simple step quite difficult by leaving out the word "socket."

**High Stability RESISTORS  
IN RESIST-O-FILE CABINETS**

**"CARBOMITE"  
TYPE MC**

Arranged for stocking and dispensing handy assortment of resistors most popularly used in radio and television servicing. Five "Carbomite" type M resistors mounted on a 3 x 5 card and filed by RETMA numerical sequence for ready selection. RESIST-O-FILES arranged for 1/2 watt, 1 watt or 2 watt; all 10% tolerance. Refills are available from your distributor.

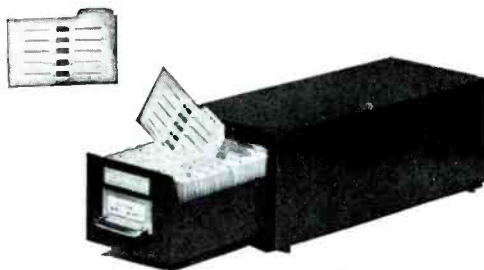

Code MC1/2, 1/2 watt consists of 200 resistors, 5 each with resistance values of: 10, 15, 22, 33, 47, 68, 100, 150, 220, 330, 470, 680, 1000, 1500, 2200, 3300, 4700, 6800, 10K, 15K, 22K, 33K, 47K, 68K, 150K, 220K, 330K, 680K, 1.5 Meg, 3.3 Meg, 4.7 Meg, 6.8 Meg and 10 Meg, and 10 each of: 100K, 470K and 1 Meg.

Code MC1, 1 watt consists of 200 resistors, the same values and quantities as MC1/2 assortment.

Code MC2, 2 watt consists of 150 resistors, 5 each with resistance values of: 10, 15, 22, 47, 68, 100, 150, 220, 330, 470, 680, 1000, 1500, 2200, 3300, 4700, 6800, 10K, 15K, 22K, 33K, 47K, 68K, 100K, 150K, 220K, 330K, 470K, 680K, and 1 Meg.

SEE OUR LOCAL DISTRIBUTOR

**CONTINENTAL CARBON, INC.**

13900 LORAIN AVE. CLEVELAND 11, OHIO



CLEARWATER 1-6500

## Audio Facts

(Continued from page 27)

sections of C1 were connected in parallel to obtain 40 mfd for the input filter capacitor. This application is not critical, and many suitable capacitors are available.

The 25.2-volt AC secondary of the power transformer is utilized in the DC heater supply section. A 25-volt AC, 300-ma DC, single-phase bridge type of selenium rectifier M3 operates very well in this circuit. The full-wave rectified output is also to be appreciated, because filtering requirements are held down to reasonable amounts of capacity.

Size and availability were factors considered when the two 500-mfd, 25-volt electrolytic filter capacitors were selected for the heater-supply section. These are also made in the tubular pigtail type. Dual 500/500-mfd, 25-volt capacitors are manufactured but are not available as regular catalog items.

A 25-ohm 10-watt adjustable resistor R4 provides for any needed adjustment in voltage applied to tube heaters. If by any chance the output voltage is too high, for instance, because of high line voltage, a 10-ohm resistor can be inserted into the circuit in series with R4 in order to allow the desired voltage to be covered.

The 6.3-volt secondary is not used in this unit. A logical use for it would be that of furnishing power to light the system's pilot light.

An AC receptacle controlled by the ON-OFF switch is always a convenient feature, because it allows the switch to control the AC power operating the rest of the equipment.

An S-304-AB Jones socket was used as the power-output connector because this type connector has been used for this service for some time. Any appropriate connector could be used instead.

The standard 5-inch by 7-inch by 2-inch chassis was used because it is so conventional and offered no complications in mounting or spacing of components.

There is probably no limit in the number of ways and places in which the components could be mounted, for they are not bulky or critical with regard to location. The complete supply could be constructed on the chassis of the preamplifier or on whatever piece of equipment to which it is supplying power. For example, the power supply of the

## PARTS LIST

### POWER TRANSFORMER

T1	Stancor PC 8417	Primary 117V AC	Secondary 1 449V AC @ 50 ma DC	Secondary 2 25.2V AC @ .5A	Secondary 3 6.3V AC @ .6A
----	-----------------	-----------------	--------------------------------	----------------------------	---------------------------

### CAPACITORS

Cap.	Volt.	Aerovox	Cornell-Dubilier	Mallory	Sprague	Sections connected in parallel for 40 mfd
C1	20	350	AFH2-37	B030	FP227	TVL-2626
	20	350	AFH2-37	B030	FP227	TVL-2626
C2A	20	350	AFH2-37	B030	FP227	TVL-2626
C2B	20	350	AFH2-37	B030	FP227	TVL-2626
C3	500	25	AFH-08	A0 12	WP057	TVL-1220
C4	500	25	AFH-08	A0 12	WP057	TVL-1220

### RESISTORS

R	Resistance	Watts	IRC	
R1	47Ω	1	BW1-47	Wire Wound
R2	2200Ω	1	BTA-2200	
R3	2200Ω	1	BTA-2200	
R4	25Ω	10	1 3/4AA-25	Adjustable

### SELENIUM RECTIFIERS

M	Seletron	Federal	Mallory	Sarkes-Tarzian	International
M1	(1) 16Y1 or (2) 8Y1	(2) 1159	(2) 8S20	(2) 35	(2) CR20
M2	(1) 16Y1 or (2) 8Y1	(2) 1159	(2) 8S20	(2) 35	(2) CR20
M3	P1B1S1C	1016		304 B	JD507G

### MISCELLANEOUS

1 Chassis, 5in. x 7in. x 2in.	1 AC Line Cord
1 Power-Output Socket	Misc. Hardware
1 AC Receptacle	Jones S-304-AB
1 Toggle Switch	Amphenol 61-MIP-61F

preamplifier-and-control unit described in PF INDEX No. 33 could be removed and this supply assembled on the chassis in its place.

Those who wish to use this power supply with the preamplifier can follow the partial schematic in Fig. 4 which indicates where the original power supply is to be dis-

connected, and Fig. 5 shows how this one is connected into the circuit.

The filament leads must be removed from the sockets, as shown in Fig. 4, and the filament circuit rewired in series parallel, as laid out in Fig. 5. This changes the heater requirements from 6.3 volts at 450 ma to 18.9 volts at 300 ma.

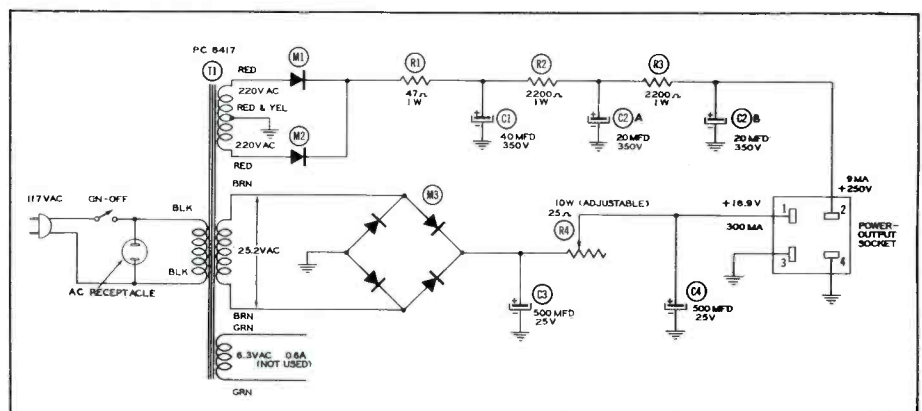
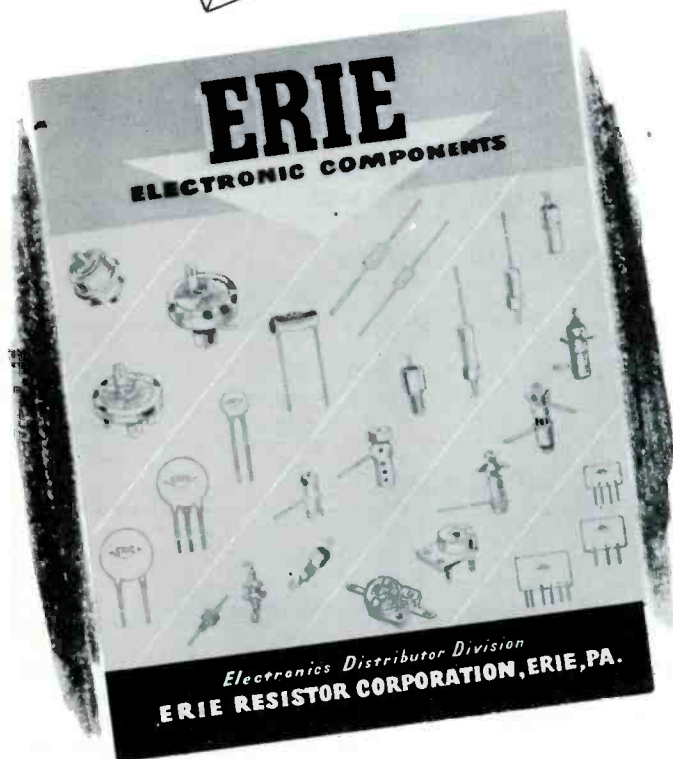

Fig. 3. Circuit Diagram of Power Supply.

# new ERIE "D-54" catalog



The new ERIE "D-54" Catalog includes descriptions of the new line of Temperature Compensating Tubular Ceramicons and Disc Ceramicons . . . plus the long-time ERIE Standard numbers and all items introduced since publication of our last catalog. Many items are illustrated.

Ask for it at your distributors, or  
Write Dept. D for your copy.

ERIE components are stocked by leading electronic distributors everywhere.

**ELECTRONICS DISTRIBUTOR DIVISION**  
**ERIE RESISTOR CORPORATION**  
Main Offices: ERIE, PA.  
Factories: ERIE, PA. • LONDON, ENGLAND • TRENTON, ONTARIO

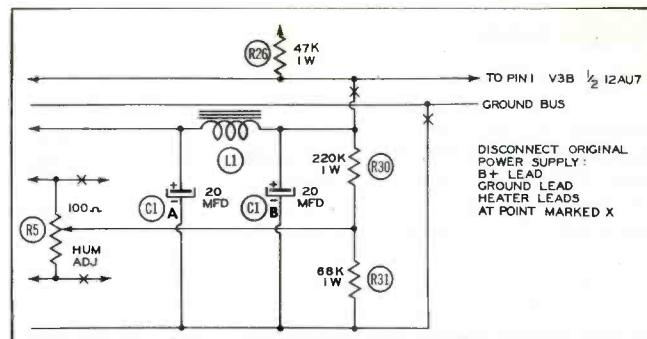

Fig. 4. Partial Schematic of Preamp and Control Unit Illustrating Where Original Power Supply Is Disconnected.

The B+ lead in the preamp is disconnected from the filter (L1, C1B, and R30 in the preamp) at the point indicated by an X in Fig. 4. The output of the new supply is then connected as shown in Fig. 5.

A Jones plug can be used to make the connections to the preamp, as shown in Fig. 5. If the supply is built in as part of the preamp, no connector is required.

The DC heater supply can be used with other tube arrangements, but voltage and current demands must be kept within normal limits.

The Triad Transformer Manufacturing Company supplies a transformer which can be used if a lower plate-supply voltage is permissible. It has no 6.3-volt secondary. The secondary to be used for the DC heater supply is tapped and allows flexibility in the selection of voltage output. Its specifications are:

Primary: 118 volts AC, 60 cps.

Secondary: 130 volts AC at 20 ma DC.

Secondary: 0 to 15, 22.5, and 30 volts AC at 600 ma rms.

This small power supply can be expected to give consistent and stable operation, because we have experienced no trouble whatsoever during the long period of time that we have had these units in actual use. There has been no failure of any component parts, although most of the operating time has been under unusually high line-voltage conditions.

A DC filament supply is worth while since, through its use, leads carrying 60 cps AC can be eliminated completely from inside the chassis involved. The fact that DC is used to heat the filaments of low-level stages in so much professional equipment is a good indication of its value.

Robert B. Dunham

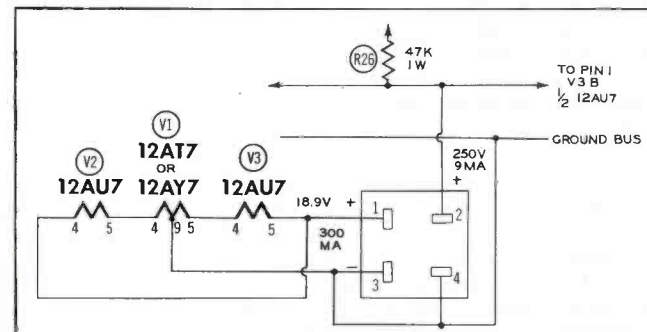

Fig. 5. Partial Schematic Showing How the New Power Supply Is Connected to the Preamp and Control Unit. Tube Filaments Are Connected in Series Parallel.

## Examining Design Features

(Continued from page 23)

deflection coils by means of an autotransformer.

### Horizontal-Sweep System

The horizontal-sweep section employs the familiar pulse-width system. The grid circuit of the horizontal AFC tube contains a horizontal-lock control to adjust the level of pulses that are applied to this stage. The plate voltage on this tube is adjusted by means of the horizontal-hold control. The horizontal-output tube is a 25BQ6.

### Power Supply

The low-voltage power supply utilizes two selenium-rectifier stacks in a voltage-doubler circuit. A pi-type filter is used. In order to conserve power and provide a more efficient system, several tubes are placed in series with the audio-output tube. A schematic of this system is shown in Fig. 6.

The filament string is connected in a series-parallel arrangement. A heater-current limiting resistor is placed in series with the string. This resistor has a negative temperature



Fig. 7. The Flush Wall Model 5P.

coefficient and has a resistance of 125 ohms when cold. At the normal operating temperature, the resistance decreases to a value of 43 ohms.



Fig. 8. The Flush Wall Radio Hinged Down for Tube Replacement.

## FLUSH WALL MODEL 5P

The Flush Wall Radio Company produces an AM radio which is designed for flush mounting in a wall. This unit is a five-tube AC-DC receiver enclosed in a steel case and is shown in Fig. 7.

Installations of this type frequently pose a servicing problem because of the inaccessibility of the units. This, however, is not the case with the Flush Wall radio. The chassis is hinged to the steel cabinet so that the removal of one screw in the front panel permits the chassis to be folded down. All tubes are exposed, and replacement becomes a simple matter. Fig. 8 illustrates the radio in this position.

If it becomes necessary to remove the receiver completely, the two screws securing the hinges to the steel cabinet are loosened. The line cord is removed from the socket located at the rear of the case, and the antenna is disconnected. The receiver is then removed from the enclosure.

DON R. HOWE

**NOT**  
**Making Hay While the Sun Shines!**

When you spend valuable job time looking for tools that hide like the famous needle in a haystack — you're losing money! With this XCELITE No. 127 Lockable Wall Set, you've got 3/16" thru 3/8" regular nut drivers

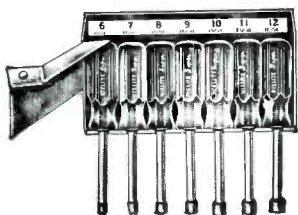

right where you want 'em! Tamper-proof! "Borrow"-proof! Color-Coded handles (now on ALL XCELITE nut drivers)!

Other quality XCELITE sets like this No. 127 to help you make hay while the sun shines! Ask your supplier!

**XCELITE, INCORPORATED**

(Formerly Park Metalware Co., Inc.)

DEPT. Q  
ORCHARD PARK, N. Y.

*For Originality*  
**LOOK TO XCELITE**

## Dollar and Sense Servicing

(Continued from page 29)

**PENNY MATCHING.** Whereas chances of winning at the game of penny matching are 50-50 over a long period of time, engineer D. W. Hagelbarger has built an electronic penny-matching robot that wins from 55 to 60 per cent of the rounds. Using intricate computer and electronic memory principles, the machine analyses certain patterns in a player's sequence of choice. As an example, if a player has won a round, played the same thing and won again, he may habitually change his choice for the third round. The machine keeps count of situations like these and, if such tendencies appear, plays in such a way as to win. When no patterns appear, the machine plays at random.

It appears to be difficult for a human being to make a strictly random choice of heads or tails, and it is still more difficult actually to beat the machine by leading it on to suspect a pattern and then by reversing the pattern.

Next, the engineers built a smaller machine with a different type of brain for determining when to play at random and when to assume a behavior pattern. Unable to decide mathematically which was the better, they hooked the two machines together and used a third machine as umpire for passing information back and forth. The robot game was allowed to run for several hours, to the accompaniment of side bets and cheering. The smaller machine, thinking faster with less brain, won out at 55 to 45. Fool's luck?

**TAPE NAME.** Winner in Tape Recording magazine's name contest for tape equivalents of record, recorder, and recording was Ken Maxwell of Longview, Texas. There were 600 entries. The three winning equivalent names will not be revealed, according to the publisher, because "no one came up with something that sounded catchy or that wasn't already in use." Now we don't feel so bad about having been completely unable to dream up a possibility.



**DEAD-ON-ARRIVALS.** When you take a TV set out of its sealed carton today in your shop or in a home, chances are about 85 out of a hundred that it'll work when hooked up to an antenna and plugged in. Five years ago these odds were 50-50 on the average, with some makes and models requiring practically 100 per cent repair or at least touch-up of adjustments by a service technician.

Customers have sensed this great improvement, for more and more of them are buying sets from discount houses and doing the installing themselves. This isn't as bad as it sounds for technicians, because these cus-

tomers feel they're a bit ahead of the game and are much more likely to pay a fair price for service when they do need it. It's the public that has always controlled the radio industry, so we might as well recognize their buying moods and take advantage of them, instead of griping about the discount houses.

There's little likelihood that manufacturers will be able to improve this dead-on-arrival situation any more, because the remaining trouble just can't be prevented economically at the factories if they are still to produce sets to sell as low as they now do. Half the troubles are miniature tubes that go bad mechanically or electrically during the trip from the factory to the shop or home. Pre-aging of tubes and more rigid factory tests before putting tubes into sets would catch some of the weaklings, but this practically doubles the cost of the tubes.

The other 7 1/2 per cent of in-the-carton troubles vary considerably. Poor sockets occasionally allow miniature tubes to pop out during shipment. Single-spring ion traps shift position. Components fail under vibration during transportation. Rosin joints open up. Parts shift so that leads touch and cause shorts. The cabinet gets

damaged when truckmen allow the carton to drop or roll off a truck. The pattern of defects shifts daily because so many are traced to human errors.

Chief reason for ability of sets to take it better in transit is the development of improved deflection-system mountings in the past few years. These are now able to hold the deflection yoke and focus coil or magnet in precisely the positions at which they were set in the factory.



**TALKING BIBLE.** To promote its new four-speed changer, the V-M Corporation is giving a 16 2/3-rpm talking-Bible record with each sale of its new model 121-A portable phonograph. Samples of these records were heard some time ago, with "whodunnits," poetry, drama, and famous books all coming through clearly. There's a battle blowing up between magnetic tape and these slow-speed discs for the talking-book business. Big money is involved with equally terrific returns to service technicians, if the public should swing over suddenly to talking books as a relaxing relief from tensions of television.

## Mr. Electronic Service Technician

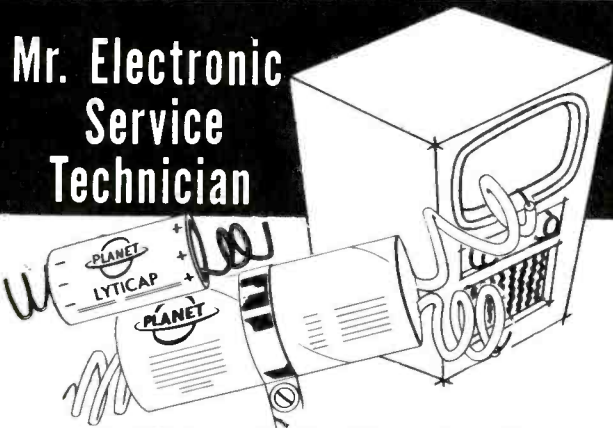

You have seen and will continue to see, in the chassis of TOP-NAME Radio and TV sets, an increasing number of Planet electrolytic capacitors — conspicuous because of their shiny red cardboard jackets. They are in those quality sets because components engineers have proven for themselves that PLANET condensers are "ENGINEERED FOR QUALITY".

You can take advantage of their findings by purchasing from your distributor Planet universal replacement types of the same high standard of quality. Ask for PLANET by name.

Write now for **"ENGINEERED FOR QUALITY"** latest FREE catalog. **GUARANTEED FOR ONE YEAR**

**PLANET** PLANET MANUFACTURING CORPORATION  
225 BELLEVILLE AVENUE  
BLOOMFIELD, N. J.

## New Low Price on Model 11 Equipto Cabinet



Larger production runs on the immensely popular Model 11 Equipto Small Parts Cabinet permit a substantial reduction in price without slightest change in quality. And look at these value-packed features—

- One-piece heavy gauge steel frame 34" x 13 3/4" x 12".
- Sturdy steel drawers that slide freely without swaying or sticking.
- Fully enclosed sides and bottom of drawers to prevent escape of parts.
- Adjustable dividers to separate each drawer into 3 compartments.
- Olive green baked enamel finish.

See your Equipto jobber or write us for complete catalog and prices.

# Equipto

Division of  
Aurora Equipment Company  
830 Prairie Avenue, Aurora, Illinois

Steel Shelving . . . . . Parts Bins . . . . . Drawer Units





# SUPERIOR'S NEW MODEL TV-40 C.R.T. TUBE TESTER



★ A complete picture tube tester for little more than the price of a "make-shift" adapter!!

★ Tests all magnetically deflected tubes . . . in the set . . . out of the set . . . in the carton!!

**SPECIFICATIONS:**

- Tests all magnetically deflected picture tubes from 7 inch to 30 inch types
- Tests for quality by the well established emission method. All readings on "Good-Bad" scale.
- Tests for inter-element shorts and leakages up to 5 megohms.
- Test for open elements.

**EASY TO USE:**

Simply insert line cord into any 110 volt A.C. outlet, then attach tester socket to tube base (Ion trap need not be on tube). Throw switch up for quality test . . . read direct on Good-Bad scale. Throw switch down for all leakage tests.

Model TV-40 C.R.T. Tube Tester comes absolutely complete—nothing else to buy. Housed in round cornered, molded bakelite case.

**\$15<sup>85</sup>** NET

**AT YOUR  
RADIO PARTS  
JOBBER**

Write Dept. PF-6 for catalog of complete line.



**SUPERIOR INSTRUMENTS CO.**  
2435 White Plains Road New York 67, N. Y.

## Notes on Test Equipment

(Continued from page 13)

ment of the beam-positioning magnets. R, G, and B indicate the red, green, and blue dots seen on the screen when the DC convergence control is improperly adjusted. Three hundred such groups of dots should be visible on the screen. A group near the center of the screen should be examined to see whether the dots form the points of an equilateral triangle. If that is the case, then adjustment of the DC convergence control should cause the dots to move through the path of the dotted arrows; and they should coincide at the intersection of the paths to form a white dot. If the red, green, and blue dots cannot be made to converge at a single point in this manner, then one or more of the three beam-positioning magnets should be adjusted for that condition.

A diagram of the relative positions of the color guns and the beam positioning magnets is shown in Fig. 3. The view is from the front of the color tube. The magnets are threaded throughout their entire length and are adjusted by turning them in or out. The greatest effect of any one magnet is upon the beam nearest it, but the other two beams are affected slightly. If the desired effect cannot be obtained, a magnet may be rotated end for end and tried in that position. The final adjustments should leave the magnets as far as possible from the neck of the tube while still obtaining satisfactory convergence.

When the DC convergence has been satisfactorily adjusted, the dynamic-convergence adjustments may be made. In effect, what is done is the superimposing of an AC voltage on the DC voltage already applied to the convergence grid of the color tube. Fig. 4 should explain why this is necessary. It can be seen that the distances the beams must travel to the shadow mask are not equal at all points of the screen, being appreciably greater at the outer margins than at the center. Therefore the angle of convergence must receive some compensation as the beams sweep near the outer margins of the screen.

Proper adjustment of the dynamic-convergence controls is indicated when optimum convergence is obtained at all points on the screen with a single setting of the DC convergence control. The vertical-dynamic-convergence amplitude control is first adjusted so that optimum convergence of the dots is the

## FIND THE RIGHT TV Yoke Capacitor IN A JIFFY!

**SPRAGUE** TV YOKE CAPACITOR  
REPLACEMENT KIT  
All Distributors  
EVERYWHERE, U. S. A.

Just try the different ceramics in this Sprague TV Yoke Capacitor Replacement Kit until you get a good picture. That's all there is to it! 36 famous Sprague Cera-Mite® Capacitors, in eight different values selected and proportioned on the basis of actual need, providing complete coverage of fractional values between 33 mmf and 82 mmf. The tiny ceramic discs fit any yoke assembly . . . stand up under the toughest service . . . are excellent replacements for any 2000 volt capacitor which may appear in original equipment. Complete instructions are on the face of the tough, paper-board card, conveniently punched for hanging over the service bench. Get yours now! Ask your distributor for Sprague Kit CK-1. Only \$12.60 List!

**SPRAGUE PRODUCTS COMPANY**  
Distributors' Division of the Sprague Electric Co.  
NORTH ADAMS, MASS.

## ATLAS RADIALS

FOR CHURCHES



FOR FACTORIES

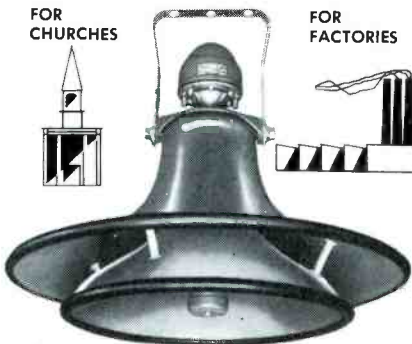

FOR TERMINALS



FOR CARNIVALS

With uniform 360° coverage, non-resonant construction, and 100% storm-proofing, ATLAS Radial Driver Unit Projectors often solve the most difficult sound problems—are excellent for reproduction of speech, chimes and music. For complete details on Radials and the famous ATLAS line of Public Address and Microphone Stand Equipment . . .

WRITE NOW for FREE Catalog 553



**ATLAS  
SOUND CORP.**

1448 39th St., Brooklyn 18, N. Y.  
In Canada: Atlas Radio Corp., Ltd., Toronto, Ont.

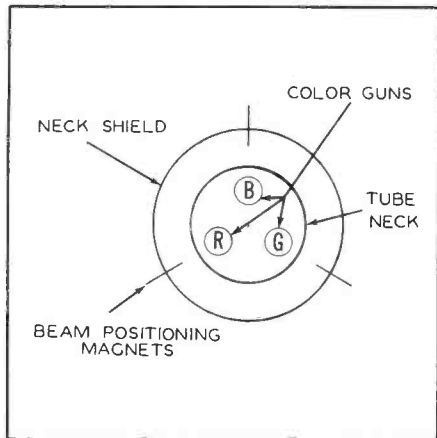

Fig. 3. Diagram Showing Relationship of Beam-Positioning Magnets to Color Guns.

same for groups near the top, center, and bottom of the screen. If necessary, the vertical-dynamic-convergence phase control should be adjusted for this condition. The dots should be kept in focus throughout the convergence adjustments by readjusting the focus control when necessary.

In like manner, the horizontal-dynamic-convergence amplitude control should be adjusted so that optimum convergence of the dots is the same at the right and left edges as well as at the center of the screen. If necessary, the horizontal-dynamic-convergence phase control should be adjusted for this condition.

The technician may find it just as easy to use the bar patterns from the generator when making the dynamic-convergence adjustments. When making the vertical convergence adjustments in this manner, the horizontal-bar pattern would be used and the adjustments made for the least amount of color fringing; when making the horizontal convergence adjustments the vertical-bar pattern would be used.

The convergence, focus, and color-purity controls are all more or

less interactive so that it may be necessary to make slight readjustments for color purity if the convergence adjustments have been extensive. This, in turn, may necessitate slight readjustments of the convergence controls.

The technician will probably find that all of these adjustments will require some time and patience at first; but after a few receivers have been adjusted and the effects of each control noted, a knack will soon be acquired.

#### Additional Data on Selenium Rectifier Testing

An article on selenium-rectifier testing appeared in this column in the April issue of the PF INDEX. In Table II (on page 75) listing selenium rectifiers and current ratings, Models 50 and 400 should be added to the Sarkes-Tarzian column, and Model 350 in the same column should read 350A.

#### New Handle for Simpson Model 260 VOM

The Simpson Electric Company of Chicago announced that their Model 260 volt-ohm-milliammeter will incorporate a new utility handle. This handle which carries the trade name "Adjust-A-Vue Handle," is strongly constructed of steel coated with the same tough Durez plastic used in the manufacture of the case. The smooth finish of the handle allows it to stay cleaner in service than other more porous materials. The technician may use the handle as a prop to adjust the instrument at any convenient viewing angle while servicing.

#### Amendments to Features of Jackson CRO-2 Oscilloscope

The Jackson Electrical Instrument Company has made some re-

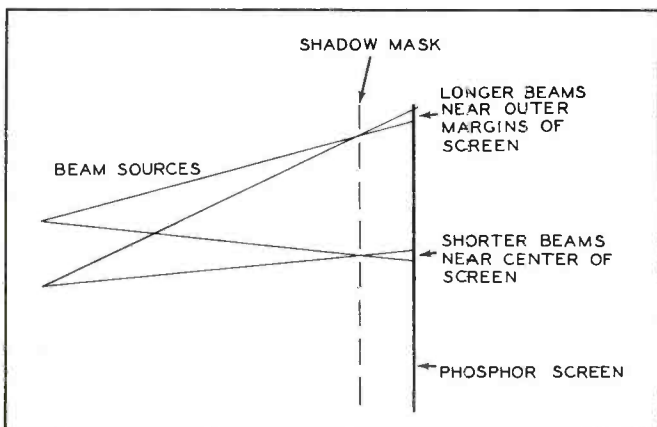
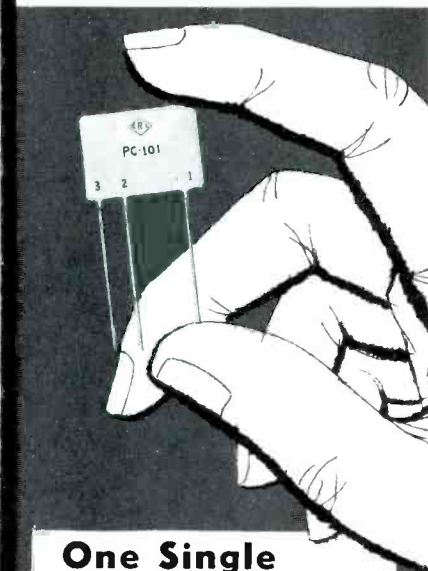

Fig. 4. Diagram Showing Need for Dynamic Convergence in a Shadow-Mask Color Tube.

**Saves service time!  
Reduces your  
investment in parts!**



**One Single  
Centralab  
Printed Electronic  
Circuit\***

**replaces several old-style  
individual components**

**And its stability assures long  
life . . . happier set-owners**

When you run up against one of the millions of old radio and TV sets that were built before PEC's were used, do you waste costly time trying to locate a shorted or intermittent component?

You don't have to—you can replace an entire section of an old-style circuit with a single PEC. And you can do it at a part-cost of as little as 36¢ to 81¢ net!

For example, if the trouble is in the vertical integrator of a TV set, you can replace the whole section with a vertical-integrator PEC plate. If the trouble is in the audio detector of a radio set, you can replace the entire section with an audio-detector PEC plate.

Why risk service "call-backs", by replacing only one old-style component? All the other parts are the same age—replace 'em all with one PEC.

New, revised Centralab Printed Electronic Circuit Guide No. 3 tells the whole story—and shows circuit schematics that help you install PEC's. \*Trademark

Write for your copy to CENTRALAB,  
A Division of Globe-Union Inc.  
942F E. Keefe Avenue, Milwaukee 1, Wis.

**Centralab**

A DIVISION OF GLOBE-UNION INC.  
Milwaukee 1, Wisconsin  
In Canada  
804 Mt. Pleasant Rd., Toronto 12, Ontario

Y-2854

# LOOK-ALIKES *won't do!*

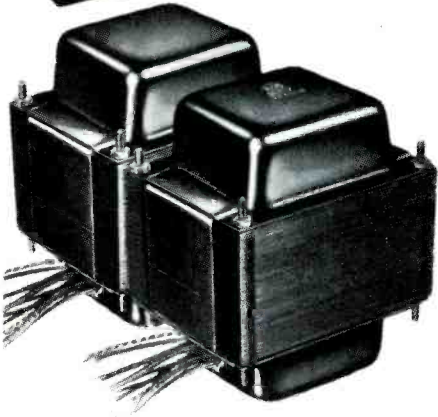

## To restore original performance in RCA Victor TV sets use genuine **RCA VICTOR** Service Parts

Remember . . . *only* genuine RCA Victor Service Parts are tailored to the chassis . . . both mechanically and electrically. They are the *only exact* replacements for RCA Victor television, radios, and phonographs.

You benefit these 5 ways when you use genuine RCA Victor Service Parts . . .

- Direct mechanical fit
- Exact circuit replacement
- Less installation time
- No need for extra parts
- Original performance assured

Be sure — use genuine RCA Victor Service Parts—and enjoy a more profitable service business.

Get a copy of the new RCA Victor TV Service Parts Guide (SP-2001) from your RCA Distributor today. Lists key parts for 249 RCA Victor TV receivers.



**RADIO CORPORATION of AMERICA**  
SERVICE PARTS HARRISON, N. J.

visions and additions to the features of the Model CRO-2 oscilloscope. The scope is still known as the Model CRO-2, but instruments having serial numbers of R5529 or higher incorporate the new features described in the following paragraphs.

A two-position toggle switch on the front panel provides for selection of a synchronization signal of either positive or negative polarity. On scopes of this model having serial numbers less than R5529, choice of sync polarity is obtained through the use of the polarity switch which also reverses the waveform polarity. This was explained in a previous article. Addition of the toggle switch allows the two functions to be obtained independently. The sync take-off point in the revised model is at the output of the first push-pull stage of the vertical amplifier.

Another new feature provides an expanded sweep for reviewing very small portions of a waveform. A combination rotary switch and control is provided on the front panel for selecting this function. With the control in full counterclockwise or OFF position, conventional sweep is obtained. When the control is rotated to the ON position, the sweep is expanded greatly and a further rotation of the control selects the desired portion of the sweep for viewing.

In order to extend the frequency response of the vertical amplifier at the high frequencies, some of the circuit components have been changed in value. The manufacturer states that with the scope in wideband position, the frequency response extends to 4.5 mc ± 1 db.

### Radio City Products Co., Model 123 Flybacker

The Model 123 Flybacker is designed for checking horizontal output or flyback transformers and deflection yokes in TV receivers. Provision is made for checks for shorts and continuity. The instrument is pictured in Fig. 5.

A short in one of the components mentioned can in most instances be very difficult to detect using a standard ohmmeter check. The change in over-all resistance when one turn of a transformer or yoke winding is shorted is too small to give an accurate indication on an ohmmeter. Yet one such shorted turn will cause the receiver to be inoperative, or the operation will be far from normal.



## you're on *easy street* with **PHOTOFACT** SCHEMATICS

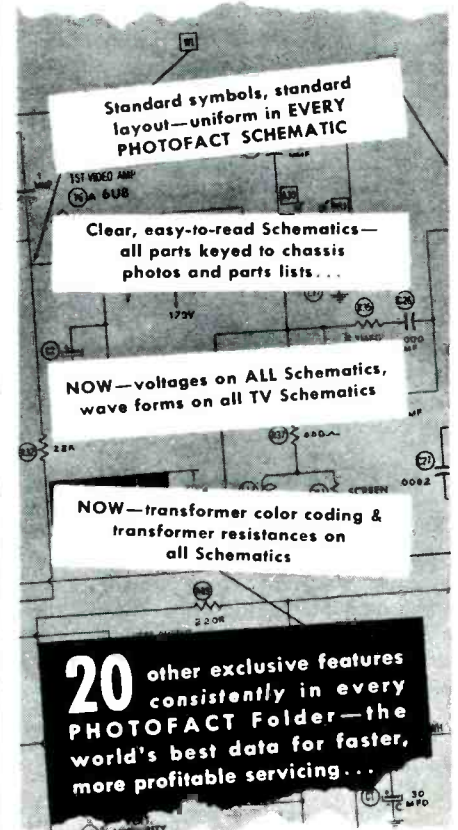

### NOW! GET THE PROOF FOR YOURSELF!

**FREE** We'll send you a Free Photofact TV Folder—just ask us for it!

Learn for yourself how PHOTOFACT pays for itself by earning bigger profits for you! We'll send you the proof—a FREE specimen PHOTOFACT TV Folder that shows all the features found consistently and *exclusively* ONLY in PHOTOFACT. Send for your FREE specimen TV Folder now. Examine it. Compare it. You'll see why PHOTOFACT belongs in your shop! And you'll want to ask your parts distributor about the pay-as-you-earn-plan. Only \$25 down brings you the entire PHOTOFACT Library. Write for FREE specimen TV Folder—learn now how to earn more!

HOWARD W. SAMS & CO., INC.  
2201 E. 46th St., Indianapolis 5, Ind.

**HOWARD W. SAMS & CO., INC.**

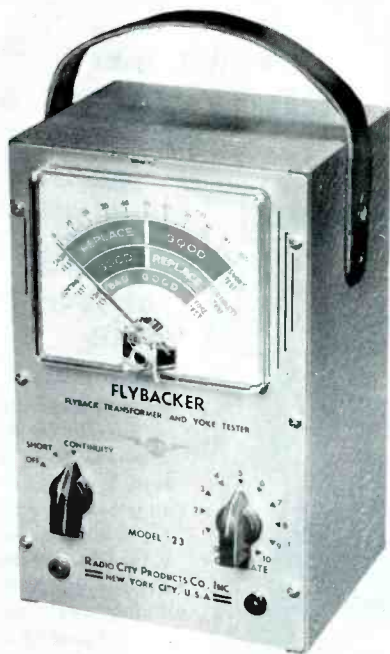

Fig. 5. RCP Model 123 Flyback Transformer and Yoke Tester.

Although the symptoms may lead the technician to suspect one of these components, he will not be certain until he has replaced the suspected part and the trouble is corrected as a result. The use of this instrument will eliminate that uncertainty, and time wasted in unnecessary replacement will be avoided.

In practice, the instrument is plugged into an AC outlet and turned on for a short warm-up period. Test leads are then inserted in their respective jacks, and the instrument is ready for use. The receiver is not in operation during tests. The instructions in the manual recommend that when checking flyback transformers, the plate connection to the horizontal-output tube should be removed, the high-voltage rectifier tube should be taken from its socket, and one end of the width coil should be disconnected from the flyback transformer. These precautions are to prevent unnecessary loading of the transformer during tests. When checking yokes, any shunting resistors should be removed from across the yoke windings.

Before connecting the flybacker to the circuit under test, the CALIBRATE control should be adjusted to set the meter pointer at CAL position on the scale. When checking low-impedance yokes, the pointer should be set at 85 instead.

The test leads are then connected to the circuit under test. When

checking flyback transformers for shorts, the leads should be placed across the primary of the transformer (the horizontal-output tube plate winding). Connection to some other, lower-impedance winding would probably cause the instrument to read in the REPLACE section of the meter scale. The TEST switch is turned to the SHORT position, and the meter will then indicate either REPLACE or GOOD on the SHORT TEST scale. If a GOOD reading is obtained, this indicates that no shorted turns are present; and a test for continuity should still be made. For continuity checks, the TEST switch is turned to CONTINUITY, and the test leads are placed across the windings to be checked. The meter is then read on the CONTINUITY test scale. The same continuity test can be applied to yoke windings, but the shorts test for yokes is read on the YOKE test scale instead of the SHORT test scale.

The Flybacker was checked recently in our laboratory on a variety of yokes and transformers and was found to give an accurate indication of their condition. A horizontal-output transformer known to be in good condition was checked for shorted turns, and the meter indication was GOOD. Then a single turn of wire was placed around the transformer winding, and the ends of the wire were shorted together to simulate a shorted turn such as might be encountered in servicing. The coupling of the shorted turn to the transformer was quite loose, yet the meter reading dropped to the REPLACE sector of the scale.

In addition to checking flyback transformers and yokes, the instrument will also check inductive windings on transformers, chokes, solenoids, relays, and the like, provided that the impedance of these units is not relatively low.

#### CURRENT RELEASES

##### Triplet Model 631

The Model 631 is a new Multi-Range meter now being marketed by the Triplet Electrical Instrument Co., of Bluffton, Ohio. This instrument is the same size as their Model 630, yet it incorporates a VTVM in addition to its functions as a volt-ohm-milliammeter. The instrument is illustrated in Fig. 6.

The Model 631 has a case made of lucite and is entirely self-contained, requiring no external connections for power. Power for its operation as a VTVM or ohmmeter is obtained from

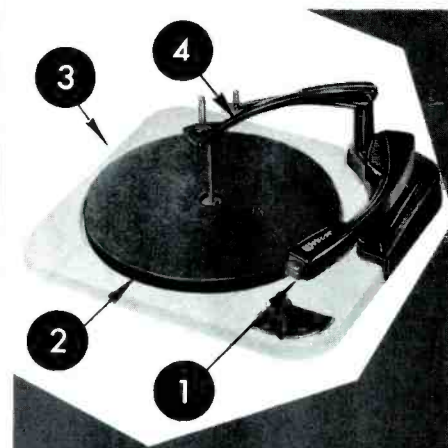

Webcor  
high-fidelity  
changers  
offer more!

In record changers it takes more than a good stylus (sapphire and diamond included) to give true high fidelity. It takes superior design, precision stamping and top quality metals. That's why Webcor Diskchangers are world renowned for TRUE high fidelity. Webcor gives you a combination of delicately designed, stamped or molded parts... all working together, smoothly, and quietly. Every Webcor changer part, from (1) the featherlight Balanced Tone Arm to the (2) super-flocked, slip-free turntable (3) powerful, constant speed, rumble-free motor and the (4) efficient, gentle changer, work together in 100% harmony. When you have a spare minute, examine the truly fine Webcor craftsmanship. Then make your next high-fidelity installation with a Webcor HF Diskchanger... from \$49.50 retail. Investigate Webcor today!

With Webcor changers you have a choice of two different sizes, three different colors, two pickups!

All music sounds better on a Webcor

**WEBCOR**

Chicago 39, Illinois

Cut  
control-  
replacement  
time and cost  
with



## Centralab Adashaft Radiohms

12 basic shaft types available from 3/8" to 10" in length, including auto types, insulating nylon, many others

Centralab's patented Adashaft design lets you (1) speed service; (2) give your customer both control and shaft for no more than the cost of an ordinary control.

The basic Adashaft control has a stub shaft you can use "as is" as a short, screwdriver-slotted unit. Or you can easily attach any of 12 basic shafts. Thus, you can have any resistance you want, including dual-tapped types — with any shaft. An instant, positive lock gives you a solid, well-aligned unit every time.

After adding the shaft you need, you can convert the unit to a switch type, with Centralab "Fastatch" type KB line switches.

Your Centralab distributor has Adashaft Controls in the popular model "B", 15/16" construction. Order from him.

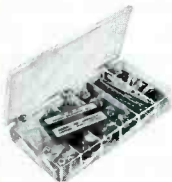

**Adashaft  
Kit No. AB-100**  
An assortment of 39 most popular controls, switches, shafts, shaft extensions, and couplers. In hinged-lid plastic box. \$13.38 net.

Write for free copy of

Bulletin 42-199

to CENTRALAB

A Division of

Globe-Union Inc.

986F E. Keefe Ave.

Milwaukee 1, Wisconsin

# Centralab



Fig. 6. Triplet Model 631 Multimeter.

internal batteries — one size-D flashlight battery and two 22 1/2-volt B batteries.

When operating as a VTVM, the input impedance is 11 megohms; as a DC voltmeter, the input impedance is 20,000 ohms per volt; and as an AC voltmeter, the input impedance is 5,000 ohms per volt.

DC volt ranges as a VTVM are 0 to 1.2, 6, 30, and 120 volts. As a VOM, the following ranges are provided:

DC volts: 0 to 3, 12, 60, 300, 1200 volts.

AC volts: 0 to 3, 12, 60, 300, 1200 volts.

DC ma: 0 to .060, 1.2, 12, 120, 1200 ma.

DC amps: 0 to 12 amps.

Ohms: x 1, x 10, x 1K, x 100K.

DB: -30 to +56.

One shielded lead is provided for VTVM readings, and a pair of test leads is provided for VOM use. DC and AC high-voltage probes are available for Model 631.

The condition of the internal batteries may be determined at any time by pressing a push button. This action permits a test of the batteries with the circuits in the meter.

Paul C. Smith

look for the  
Howard W. Sams  
"BOOK TREE"

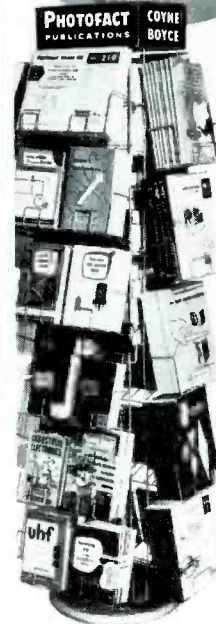

at your  
PARTS  
DISTRIBUTOR

Make it a habit to "browse" at the Howard W. Sams "Book Tree". You'll find it at your Parts Distributor. It's loaded with the time-saving, profit-making books you want and need. Keep ahead with these timely, practical publications that help you learn more and earn more daily.

### LOOK FOR THESE TITLES:

#### Television Books

"Telecasting Operations" .....	\$7.95
"Photofact Television Course" .....	3.00
"TV Servicing Short-Cuts" .....	1.50
"TV Test Instruments" .....	3.00
"UHF Converters" .....	1.00
"UHF Antennas" .....	1.50
"Television Antennas" .....	2.00
"Servicing TV in the Customer's Home" .....	1.50
"Making Money in TV Servicing" .....	1.25
"TV Tube Location Guide" Vols. 4, 3, 2, each .....	2.00
"TV Tube Location Guide" Vol. 1 .....	1.50

#### Audio Publications

"Recording & Reproduction of Sound" .....	\$7.95
"Audio Amplifiers" Vols. 4, 3, 2, each .....	3.95

#### Record Changer Manuals

"Automatic Changer Manual" Vols. 5, 4, 3, each .....	\$3.00
"Automatic Changer Manual" Vol. 2 .....	4.95

#### Handy Service Guides

"Radio Receiver Tube Replacement Guide" .....	\$1.25
"AM-FM Servicing Short-Cuts" .....	1.50
"Dial Cord Stringing Guide" Vols. 4, 3, 2, 1, each .....	1.00

#### Auto Radio Service Manuals

"Auto Radio Manual" Vols. 3, 2, each .....	\$3.00
"Auto Radio Manual" Vol. 1 .....	4.95

#### Communications Receivers

"Communications Receivers" Vols. 2, 1, each .....	\$3.00
---	--------

#### Coyne and Boyce Books

"Coyne TV Servicing Cyclopedias" .....	\$5.95
"Coyne Transistors" .....	1.50
"Coyne Practical TV Servicing" .....	4.25
"Coyne Latest Test Instruments" .....	3.25
"Coyne TV & Radio Handbook" .....	2.75
"Coyne Industrial Electronics" .....	3.75
"Boyce Video Handbook" .....	5.95
"Boyce Radio Handbook" .....	4.95

See these and dozens of other invaluable books on the Howard W. Sams "Book Tree"!

**HOWARD W. SAMS & CO., INC.**  
Indianapolis 5, Indiana

Look for these books —  
order them at your Parts Distributor

# STATUS OF TV BROADCAST OPERATIONS

## SUPPLEMENT No. 1

The following charts show the construction permits and stations which have come on the air during the period between January 1 and April 10, 1954. A third chart lists the stations that have discontinued operations and the construction permits that have been relinquished.

This supplemental data, when combined with the data presented in the February 1954 issue of the PF INDEX, presents a complete picture of the status of TV broadcast operations in the United States (including Alaska, Hawaii, and Puerto Rico).

### CONSTRUCTION PERMITS GRANTED FROM JANUARY 1 THROUGH APRIL 10, 1954

<b>ALABAMA</b> Montgomery WSFA-TV Ch. 12 Selma WSLA Ch. 8	<b>INDIANA</b> Indianapolis WISH-TV Ch. 8	<b>NEW JERSEY</b> Camden WKDN-TV Ch. 17	<b>OKLAHOMA (Continued)</b> Tulsa KSPG Ch. 17	<b>VERMONT</b> Montpelier WMVT Ch. 3
<b>ARKANSAS</b> El Dorado KRBB Ch. 10 Hot Springs KTVR Ch. 9	<b>IOWA</b> Sioux City KTIV Ch. 4	<b>NEW YORK</b> Buffalo --- Ch. 2 Carthage --- Ch. 7	<b>PENNSYLVANIA</b> Sharon WSHA Ch. 39	<b>VIRGINIA</b> *Newport News WACH-TV Ch. 33
<b>CALIFORNIA</b> El Centro KPIC-TV Ch. 16 Modesto KTRB-TV Ch. 14 Stockton KHOF Ch. 13	<b>KANSAS</b> Great Bend --- Ch. 2 Wichita KAKE-TV Ch. 10	<b>NORTH CAROLINA</b> Carolina Beach WTHT Ch. 3 Durham WTIK Ch. 11 Gastonia --- Ch. 48	<b>SOUTH CAROLINA</b> Charleston WUSN-TV Ch. 2	<b>WASHINGTON</b> Seattle --- Ch. 20 Spokane KREM-TV Ch. 2
<b>DISTRICT OF COLUMBIA</b> Washington WOOK-TV Ch. 50	<b>LOUISIANA</b> Baton Rouge WBRZ Ch. 2	<b>NORTH DAKOTA</b> Grand Forks KNOX-TV Ch. 10	<b>SOUTH DAKOTA</b> Rapid City KTLV Ch. 7	<b>WEST VIRGINIA</b> Charleston WCHS-TV Ch. 8 Clarksburg WBLK-TV Ch. 12
<b>FLORIDA</b> West Palm Beach WEAT-TV Ch. 12	<b>MICHIGAN</b> Marquette --- Ch. 6	<b>OHIO</b> *Dayton WIFE Ch. 22 Elyria WEOL-TV Ch. 31	<b>TENNESSEE</b> Chattanooga WDEF-TV Ch. 12	<b>WISCONSIN</b> Green Bay --- Ch. 5 Wausau WOSA-TV Ch. 16
<b>ILLINOIS</b> Chicago WOPA-TV Ch. 44	<b>MINNESOTA</b> Hibbing WHTV Ch. 10	<b>OKLAHOMA</b> Muskogee --- Ch. 8	<b>TEXAS</b> Corpus Christi KVDO Ch. 22 El Paso KELP-TV Ch. 13 Houston KTLJ Ch. 13 Tyler KLTV Ch. 7 *Tyler KETX Ch. 19	*Reverted from Operating Status to CP Status.

### STATIONS NOW ON THE AIR FROM JANUARY 1 THROUGH APRIL 10, 1954

<b>ARKANSAS</b> Little Rock KARK-TV Ch. 4	<b>INDIANA</b> Elkhart WSJV Ch. 52	<b>MONTANA</b> Great Falls KFBB-TV Ch. 5	<b>PENNSYLVANIA</b> Pittsburg WQED Ch. 13# Scranton WARM-TV Ch. 16	<b>WISCONSIN</b> Madison WHA-TV Ch. 21#
<b>CALIFORNIA</b> Fresno KBID-TV Ch. 53 San Francisco KQED Ch. 9# KSAN-TV Ch. 32	<b>MASSACHUSETTS</b> Adams WMGT Ch. 74	<b>NEW HAMPSHIRE</b> Manchester WMUR-TV Ch. 9	<b>RHODE ISLAND</b> Providence WNET Ch. 16	<b>WYOMING</b> Cheyenne KFBC-TV Ch. 5
<b>FLORIDA</b> Ft. Myers WINK-TV Ch. 11 Pensacola WEAR-TV Ch. 3	<b>MICHIGAN</b> Bay City WNEM-TV Ch. 5 East Lansing WKAR-TV Ch. 60#	<b>NEW YORK</b> Schenectady WTRI Ch. 35	<b>TEXAS</b> Beaumont KBMT Ch. 31	<b>HAWAII</b> Honolulu KULA-TV Ch. 4
<b>GEORGIA</b> Albany WALB-TV Ch. 10 Augusta WRDW-TV Ch. 12 Savannah WTOC-TV Ch. 11	<b>MINNESOTA</b> Duluth-Superior, Wis. KDAL-TV Ch. 3 WDSM-TV Ch. 6	<b>NORTH CAROLINA</b> Wilmington WMFD-TV Ch. 6	<b>VIRGINIA</b> Danville WBTM-TV Ch. 24	<b>PUERTO RICO</b> San Juan WAPA-TV Ch. 4 WKAQ-TV Ch. 2
	<b>MISSISSIPPI</b> Jackson WSLI-TV Ch. 12	<b>OREGON</b> Eugene KVAL-TV Ch. 13	<b>WEST VIRGINIA</b> Fairmont WJPB-TV Ch. 35	# Educational.

# STATUS OF TV BROADCAST OPERATIONS

(continued)

CP's RELINQUISHED AND STATIONS DISCONTINUING OPERATIONS FROM JANUARY 1 THROUGH APRIL 10, 1954					
<u>Relinquished</u>	LOUISIANA Alexandria KSPJ Ch. 62 Baton Rouge KHTV Ch. 40	NEW MEXICO Clovis KNEH Ch. 12	TENNESSEE Chattanooga WTVT Ch. 43	*St. Louis-Festus KACY Ch. 14	
CALIFORNIA San Bernardino KITO-TV Ch. 18 San Jose KVIE Ch. 48 Yuba City KAGR-TV Ch. 52	MICHIGAN Benton Harbor WHFB-TV Ch. 42	NEW YORK Poughkeepsie WEOK-TV Ch. 21 Watertown WWNY-TV Ch. 48	TEXAS Sherman KSHM Ch. 46	NEBRASKA *Lincoln KFOR-TV Ch. 10	
IDAHO Boise KTVI Ch. 9	MINNESOTA St. Paul WCOW-TV Ch. 17	NORTH CAROLINA Durham WCIG-TV Ch. 46 Mt. Airy WPAQ-TV Ch. 55	VIRGINIA Charlottesville WCHV-TV Ch. 64 Marion WMEV-TV Ch. 50	OHIO *Dayton WIFE Ch. 22	
INDIANA Marion WMRI-TV Ch. 29	MISSISSIPPI Gulfport WGCM-TV Ch. 56	OREGON Salem KPIC Ch. 24	Discontinuing Operations	TEXAS *Tyler KETX Ch. 19	
IOWA Cedar Rapids KEYC Ch. 20	MONTANA Billings KRHT Ch. 8 Great Falls KMON-TV Ch. 3	PENNSYLVANIA Lewistown WMRF-TV Ch. 38	ARKANSAS Little Rock KRTV Ch. 17	VIRGINIA *Newport News WACH-TV Ch. 33	
			MISSOURI Kansas City KCTY Ch. 25	WISCONSIN Oshkosh WOSH-TV Ch. 48	
				* Reverted to CP Status.	

FOR OVER

30  
YEARS

**EBY**

OF  
N. Y.



PRICE  
\$5.95  
NET

- SOCKETS (JAN APP)
- SHIELDS (JAN APP)
- BATTERY PLUGS
- PLUGS AND CONNECTORS
- RACK & PANEL CONNECTORS
- FUSE HOLDERS
- FUSE BLOCKS
- SUBMINIATURE SOCKETS
- TRANSISTOR SOCKETS
- UHF SOCKETS
- PRINTED CIRCUIT SOCKETS
- TURRET SOCKETS
- CRT SOCKETS
- HIGH VOLTAGE SOCKETS
- TEO CONTACT CLEANER
- TV HARNESSSES
- TV ANTENNA ACCESSORIES

## SUBMINIATURE POCKET TESTER

### SPECIFICATIONS:

- Low voltage tester (0-1000 volts) A.C., D.C.
- High voltage tester (50 K.V.)
- Signal tracer
- Audio Oscillator
- Condenser tester
- A.G.C. substitution voltage supply
- Visual output meter
- Continuity tester
- 3" x 4" x 1 1/4"

All EBY Products are fully stocked in New York for immediate delivery.

WRITE FOR CATALOG P

**SALES CO.**  
OF NEW YORK

130 LAFAYETTE STREET  
NEW YORK 13, N. Y.

**EBY**

## RADELCO HI-CHANNEL BROAD BAND YAGI

*Gives Clearer, Brighter*

TV PICTURES  
ON ALL 7  
HIGH BAND  
VHF CHANNELS



Ideal for areas having two or more high channel stations. Completely preassembled.

LIST

\$10<sup>20</sup>

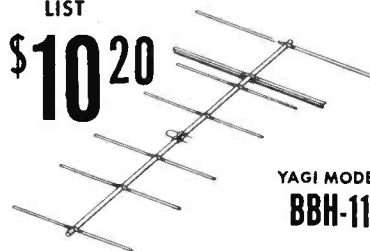

YAGI MODEL  
BBH-11

ORDER FROM YOUR  
NEAREST PARTS JOBBER



## RUB AWAY NOISE FROM TV TUNER!

with Superex  
**NEW TUNERASER**  
STICK 98¢  
NET

Removes tarnish and corrosion from all electrical contacts

Specially compounded to make turret contacts glow like new, this efficient Superex TUNERASER stick quickly, easily eliminates noise and intermitants from TV tuner. Simply rub on and watch tarnish and corrosion disappear. It's economical too! One stick lasts a year under normal use.

At Distributors Everywhere.

**SupereX** ELECTRONICS CO. successor to Grayburne  
23 Atherton St., Yonkers, N. Y.



Sarkes  
Tarzian<sup>INC.</sup>

RECTIFIER DIVISION ...

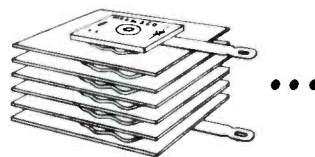

SELENIUM "Centre-Kooled" RECTIFIER

PATENTS NO. 2618692 & 2620384

PHONES 2-1435-6-7 • 415 NORTH COLLEGE AVENUE • BLOOMINGTON, INDIANA

EDWARD A. GURTOWSKI  
1452 KENHORST BLVD.  
KENHORST, READING, PA.  
Phone 4-3508

Precious Selenium

Dear Mr. Serviceman:

The President of the United States has recently stated that scarce materials vitally needed in time of emergency must be stockpiled.

Your cooperation is urgently needed in returning defective selenium rectifiers to your distributors so that selenium may be recovered and result in bringing you new rectifiers. Sarkes Tarzian, Inc. has authorized your distributor to pay you a fair scrap value price for your trouble. Thus you will profit by helping prevent a shortage of precious selenium.

Thank you again,

SARKES TARZIAN, INC.  
Rectifier Division

A handwritten signature in cursive script that reads "G. Eannarino".

G. Eannarino  
Director



INDEX TO ADVERTISERS  
June, 1954

Advertiser	Page No.
All Channel Antenna Corp.	60
American Phenolic Corp.	18
American Television & Radio Co.	56
Astatic Corp., The	50
Atlas Sound Corp.	72
Belden Mfg. Co.	26
Bussmann Mfg. Co.	22
CBS-Hytron	12
Centralab Div. Globe-Union, Inc.	62, 73, 76
Channel Master Corp.	48
Chicago Standard Trans. Corp.	36
Clarostat Mfg. Co., Inc.	10
Clear Beam Antenna Corp.	20
Continental Carbon, Inc.	66
DuMont Labs., Inc., Allen B.	4
Eby Sales Co.	78
Electronic Instrument Co., Inc. (EICO)	62
Electronic Meas. Corp.	47
Equito Div. Aurora Equipment Co.	70
Erie Resistor Corp.	68
Federal Telephone & Radio Co.	Insert
General Electric Co.	8
Granco Products, Inc.	28
Industrial Television, Inc.	32
International Resistance Co.	2nd Cover
Jensen Industries, Inc.	38
JFD Mfg. Co.	30 & 31, 46
Littlefuse, Inc.	4th Cover
Mallory & Co., Inc., P. R.	6
Merit Transformer Corp.	Insert
Ohmite Mfg. Co.	52
Planet Mfg. Corp.	70
Quam-Nichols Co.	58
Radelco Mfg. Co.	78
Radiart Corp.	34
Radio City Products Co., Inc.	66
Radio Corp. of America.	61, 63, 65, 74
Raytheon Mfg. Co.	16
Regency Div., I. D. E. A., Inc.	1
Sams & Co., Inc., Howard W.	63, 74, 76
Sonotone Corp. (Titone)	54
Sprague Products Co.	2, 72
Superex Electronics, Inc.	78
Superior Instruments Co.	72
Sylvania Electric Products Inc.	3rd Cover
Tarzian, Inc., Sarkes.	79
Triplett Electrical Instr. Co.	Insert
V-M Corporation.	64
Walsco Electronics Corp.	24
Ward Products Corp.	14
Webster-Chicago Corp.	75
Xcelite, Inc.	69

CONCERNING THE PRESENT AND FUTURE STATUS OF UHF

The subject of UHF has been kicked around quite a bit editorially in recent weeks. We have had our say about it in past issues, and for us to say more on the subject might be considered as undue emphasis on our part. However, there are a couple of items, which came to the attention of this writer just before going to press, that I think tend to clarify present conditions on the subject better than any additional words of ours.

The first item of interest concerns the formation of a UHF Policy Committee by the Radio-Electronics-Television Manufacturers Association (RETMA). Board Chairman Robert C. Sprague appointed the following members to serve:

- |                     |                                    |
|---------------------|------------------------------------|
| W. R. G. Baker -    | General Electric Co.               |
| Allen B. DuMont -   | Allen B. DuMont Laboratories, Inc. |
| E. G. Fossum -      | Stewart-Warner Electric Division   |
| Louis Hausman -     | CBS-Columbia                       |
| H. Leslie Hoffman - | Hoffman Radio Corp.                |
| A. V. Loughren -    | Hazeltine Electronics Corp.        |
| W. W. Watts -       | Radio Corp. of America             |

The president of RETMA, Glen McDaniel, was named to serve as Chairman of the Committee. The Committee will probably contribute importantly in connection with the pending investigation by the Senate Interstate and Foreign Commerce Committee of problems affecting UHF.

If there were any doubts remaining about a rough road ahead for UHF the action of the Senate Committee and RETMA would seem to eliminate them.

The second item which came to attention was the May 8 issue of Martin Codel's Television Digest, a weekly news service on happenings within the electronic industry. With Mr. Codel's kind permission, we are including excerpts from Page 2 of the subject issue, which apply to the UHF problem.

"15th STATION OFF AIR, 72nd CP RETURNED: You can expect quite a few more of today's 126 UHF stations to leave air next few months - - and perhaps a few more VHF. That is, unless some near-miracle occurs to alter the economic climate around many of them.

"We know of a dozen or more UHF stations struggling with fateful decisions - - but we add hastily that we know of many successful UHF operations. Latter go their way quietly, some even reluctant to tell their 'success stories' to upcoming Senate Committee hearings. But the limelight now seems to be on 'casualties.'

"Atlantic City's WFPG-TV (Ch. 46), second oldest UHF station, this week became latest casualty, following close on suspension of operations of WTAC-TV, Flint, Mich. (Ch. 16) and KFAZ, Monroe, La. (Ch. 43), both of which went off air May 1.

"To date, 15 stations have gone off air or announced they will go off - 12 of them UHF, 2 VHF - - not counting those which suspended and later returned. Twelve of the 15 left air since March 1, but only 5 surrendered their CPs - - the others hoping to return if conditions become more favorable.

"Total of 72 grantees have surrendered CPs since freeze - - 60 UHF, 12 VHF - including the 5 which were on air."

If these and similar reports do not convince all segments of the industry that a thoroughly cooperative approach is required on the part of networks, stations, receiver manufacturers, and retailers, then the prospects of an expanding television market throughout the country look black indeed.

- J. R. R.

While every precaution is taken to insure accuracy, we cannot guarantee against the possibility of an occasional change or omission in the preparation of this Index.

MERIT  
M  
M  
M  
M

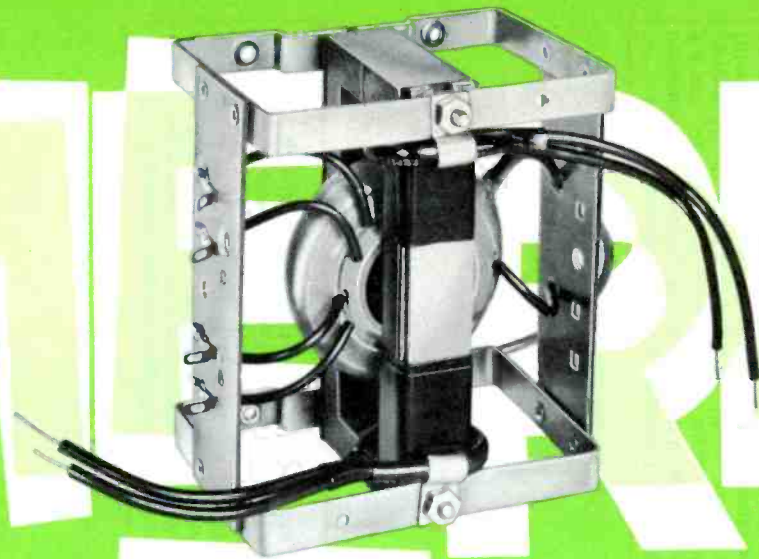

**MERIT**—the only transformer line designed exclusively for service—will be on the spot with exact replacements for color television.

Since 1947 Merit has made available to you a complete line of replacement transformers including such exact replacement requirements as Merit Model HVO-13 for Sylvania, Model HVO-16 for Philco and Model HVO-23 for Admiral.

Merit's three plants in Chicago, Hollywood, (Calif.) and Hollywood (Fla.) are geared to supply your replacement transformer needs when you need them wherever you are.

**WATCH MERIT FOR EXACT REPLACEMENT IN COLOR TV**

**AS IT HAS BEEN IN BLACK & WHITE TV SINCE 1947**



**MERIT COIL & TRANSFORMER CO.**  
4427 N. Clark Street, Chicago 40, Illinois

**LUMINANCE CHANNEL**

The luminance channel amplifies and properly delays the composite color signal which is available from the video detector. The output of this channel is the Y signal which is fed to the matrix. The Y or luminance signal is such that it produces only brightness variations on the screen. For black-and-white transmissions, only the Y channel furnishes a signal to the matrix.

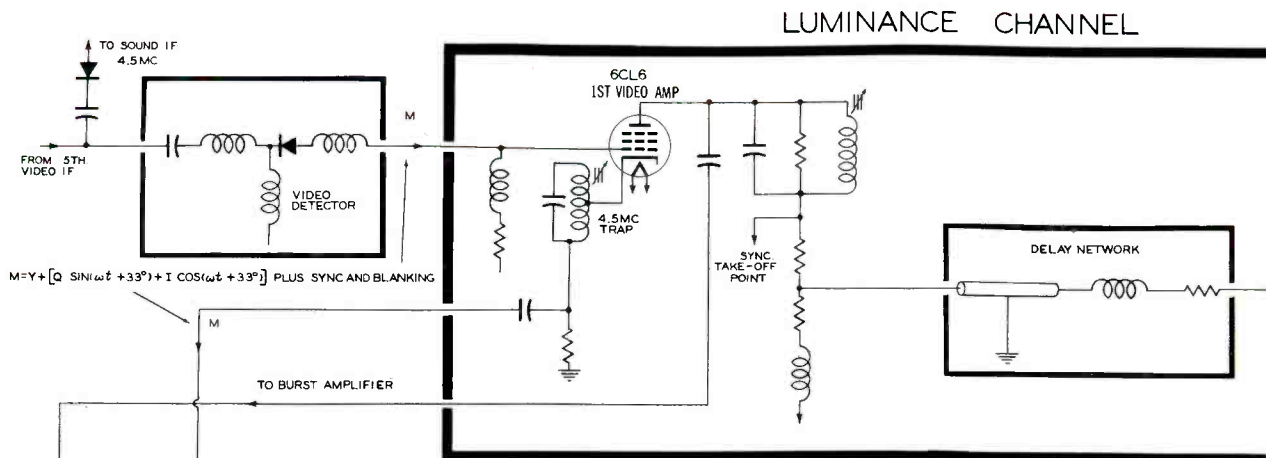

**CHROMINANCE CHANNEL**

The chrominance channel passes frequencies contained in the composite color signal between 2 and 4.4 mc. The take-off point for this signal is in the cathode circuit of the first video amplifier. After it is filtered, the signal is fed to the I and Q demodulators where it is demodulated by synchronous detector action. Two CW signals of the proper phase are fed to the demodulators in order to accomplish the detection. The outputs of these demodulators are minus-I and minus-Q signals which are then fed to phase splitters to produce plus and minus signals of both I and Q. These signals are coupled to the matrix where they are mixed in proper proportions with the Y signal.

A bias voltage from the color killer cuts off the bandpass amplifier during black-and-white reception.

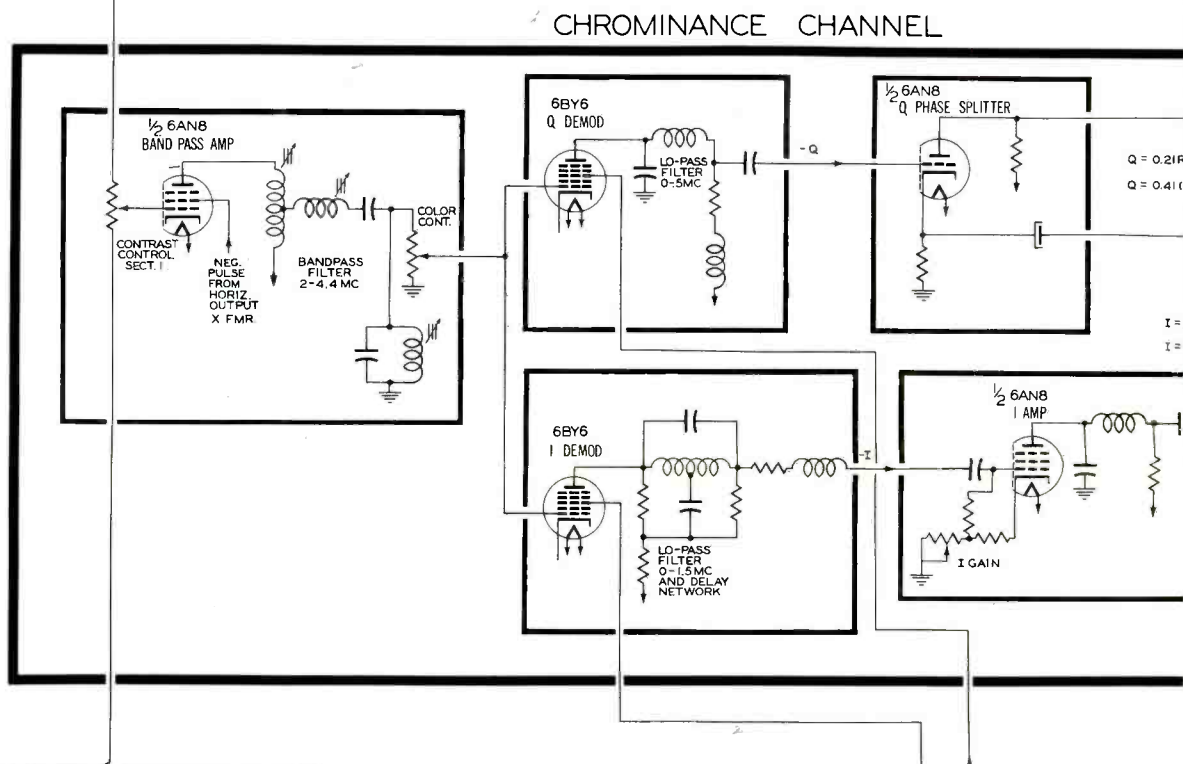

**COLOR KILLER**

The purpose of the color killer is to disable the chrominance channel during black-and-white reception. The operation of this stage is dependent upon a positive pulse from the horizontal-output transformer and upon a bias voltage from the phase detector. The voltage developed in the plate circuit of the color killer is coupled to the bandpass amplifier for biasing purposes. During color reception, the presence of the color burst results in a negative voltage being developed at the phase detector. This voltage biases the color killer to cutoff and thus permits normal operation of the bandpass amplifier.

During black-and-white reception, no color burst is present. The color killer conducts and produces a negative voltage in its plate circuit. This voltage cuts off the bandpass amplifier and disables the chrominance channel.

**COLOR KILLER**

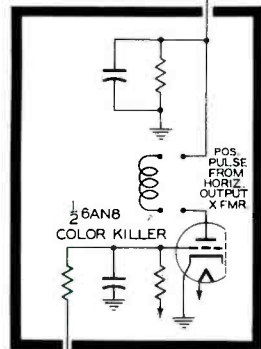

**COLOR SYNCHRONIZATION**

The purpose of the color-synchronizing section involves the generation of two CW signals which have a fixed relationship to the color-burst signal with respect to frequency and phase. These CW signals are fed to the I and Q demodulators for the purpose of demodulating the color signal.

The input signal consists of the composite color signal and is fed to a burst amplifier which, in combination with a keyer, allows only the color burst to pass. A 3.58-mc crystal oscillator is regulated by a phase detector and reactance tube combination so that it operates at the same frequency as the color burst and with a specific phase relationship to the burst. A quadrature amplifier and phase-shifting network then produce two 3.58-mc signals - one with a phase of -57 degrees with respect to the color burst, the other with a phase of -147 degrees.

**COLOR SYNCHRONIZATION**

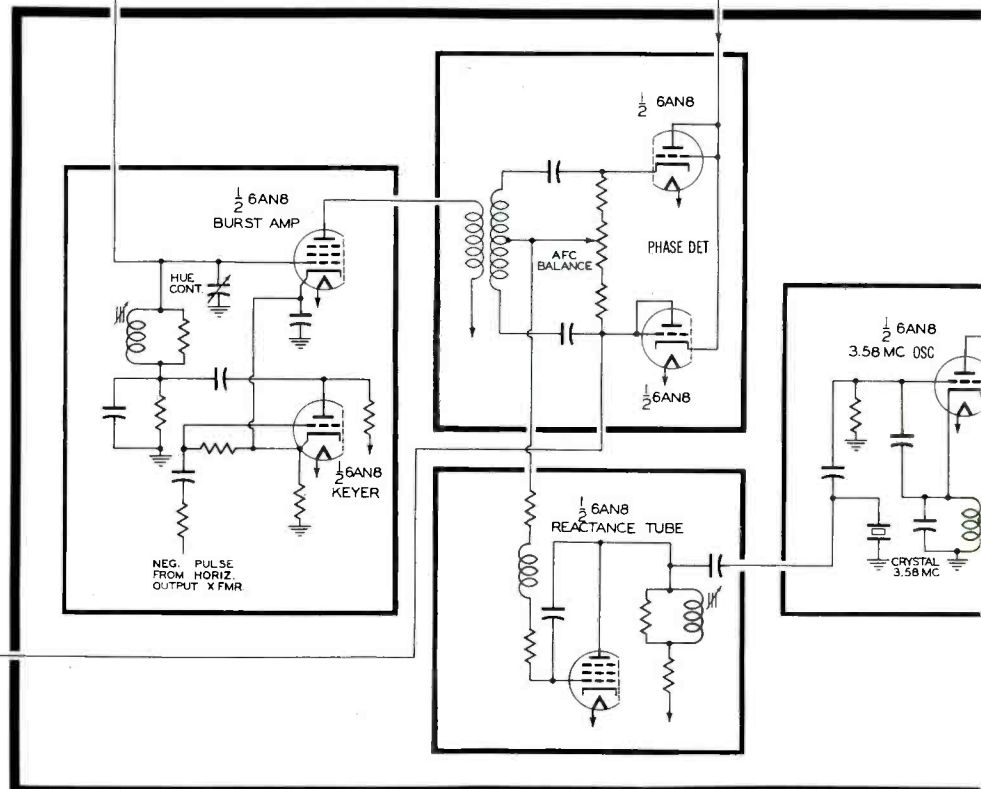

# COLORBLOCK Chart No. 1

## COLOR TRANSMISSION STANDARDS

1. Horizontal-scanning frequency = 15,734.264 cps.
2. Vertical-scanning frequency = 59.94 cps.
3. Color subcarrier and burst frequency = 3.579545 mc.
4. ERP of aural transmitter must not be less than 50% nor more than 70% of visual ERP.
5. Equations of signals involved in color transmission:

- (a)  $E_Y = 0.30E_R + 0.59E_G + 0.11E_B$
- (b)  $E_R - E_Y = 0.70E_R - 0.59E_G - 0.11E_B$
- (c)  $E_B - E_Y = -0.30E_R - 0.59E_G + 0.89E_B$
- (d)  $E_G - E_Y = -0.30E_R + 0.41E_G - 0.11E_B$  (not transmitted as such)
- (e)  $E_I = -0.27(E_B - E_Y) + 0.74(E_R - E_Y)$
- (f)  $E_I = 0.60E_R - 0.28E_G - 0.32E_B$
- (g)  $E_Q = 0.41(E_B - E_Y) + 0.48(E_R - E_Y)$
- (h)  $E_Q = 0.21E_R - 0.52E_G + 0.31E_B$
- (i)  $E_M = E_Y + [E_Q \sin(\omega t + 33^\circ) + E_I \cos(\omega t + 33^\circ)]$
- (j) For color-difference frequencies below 500 kc,  

$$E_M = E_Y + 1.14 \left[ \frac{1}{1.78} (E_B - E_Y) \sin \omega t + (E_R - E_Y) \cos \omega t \right]$$

6. Hue determines the phase of the color subcarrier.
7. Saturation determines the amplitude of the color subcarrier.

### 8. Frequency Distribution of the Color Signal

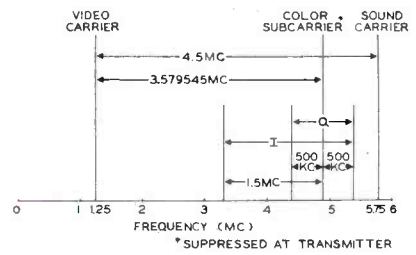

### 9. Color-Burst Specifications

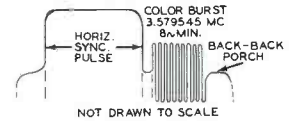

### 10. Color Phase Diagram

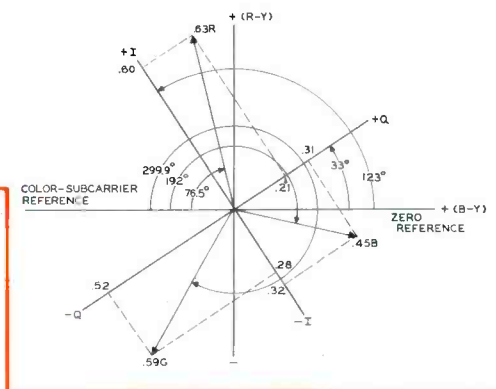

### MATRIX

The purpose of the matrix is to combine and amplify the Y, I, and Q signals in the proper proportions to produce three signals representative of the three color signals at the camera. These signals are applied to the three guns in the color picture tube and result in the reproduction of the desired color picture.

The inputs to the matrix consist of a Y signal and both plus and minus polarities of the I and Q signals. The gain of the green and blue channels in the matrix can be varied to provide proper balance in the three channels. DC restoration is provided in each channel.

### BEAM CONTROL

1. BEAM-POSITIONING MAGNETS orient individual beams so that they may be made to strike the shadow mask at the proper point and at the correct angle.
2. The PURIFYING COIL acts to align all three beams so that they strike their respective phosphor dots.
3. The FOCUS ELECTRODE in the gun structure is provided with AC and DC voltages which properly focus the beams at all points on the screen.
4. The CONVERGENCE ELECTRODE in the gun structure is provided with AC and DC voltages which properly converge the beams at all points on the shadow mask.
5. The FIELD NEUTRALIZING COIL and ANTI-MAGNETIC SHIELDS about the tube counteract the influence of external magnetic fields.

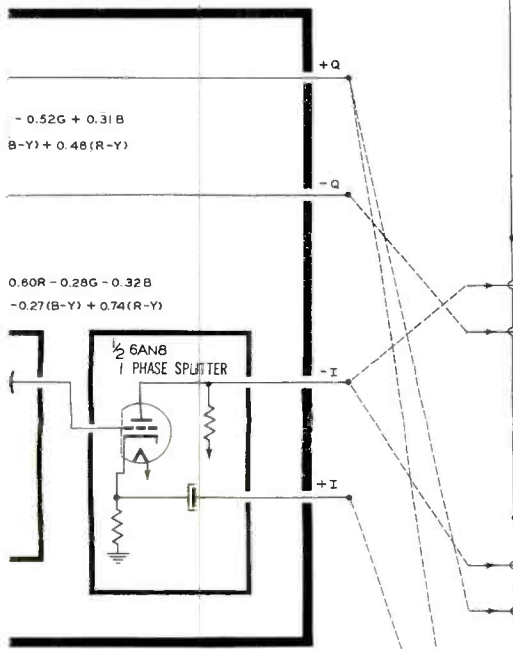
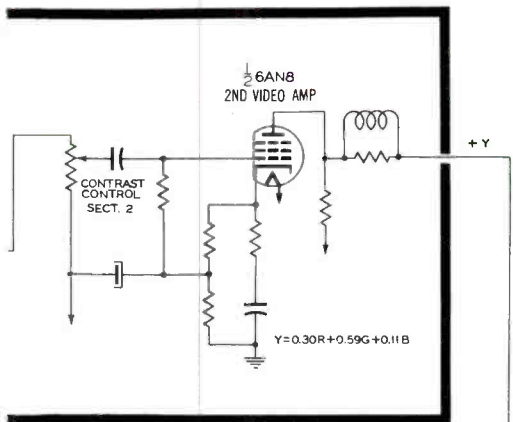

BURST - 147°  
URST - 57°

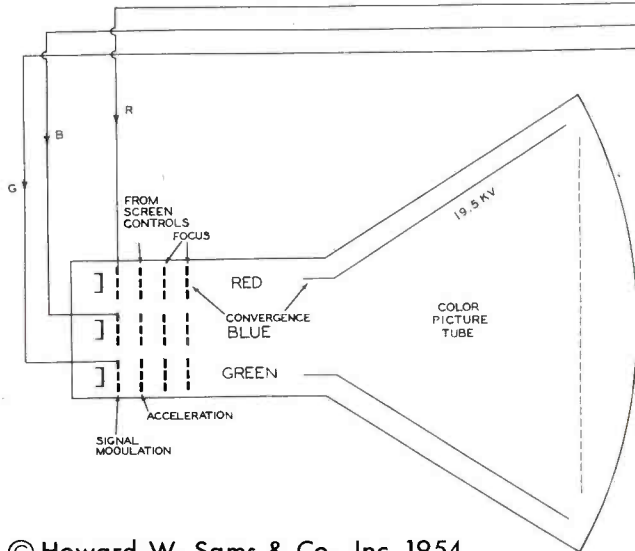
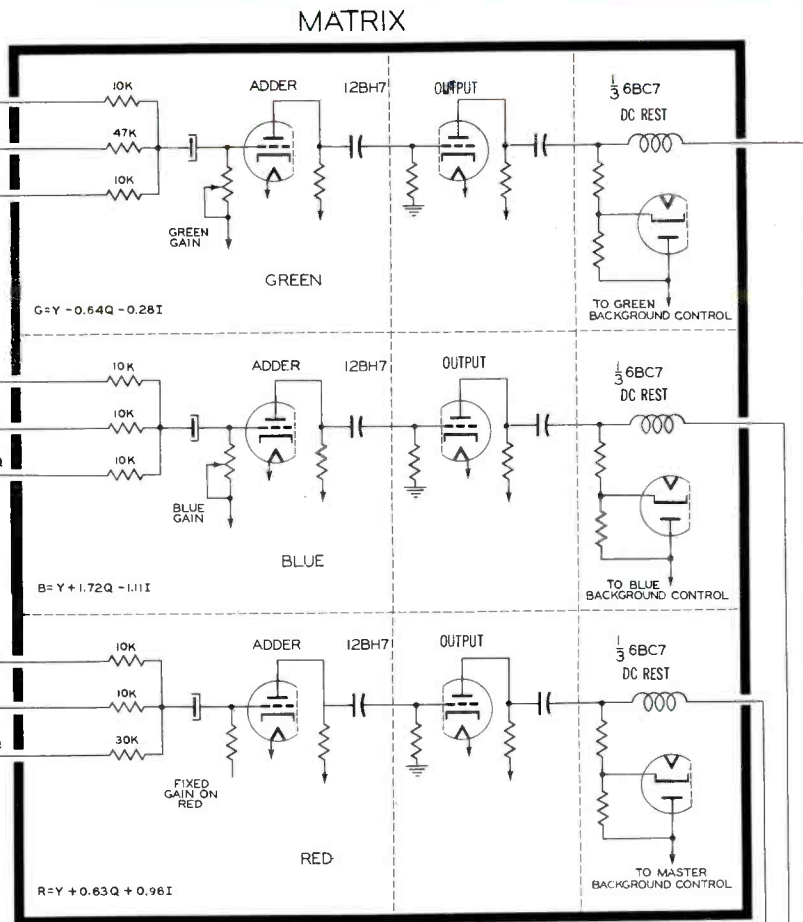
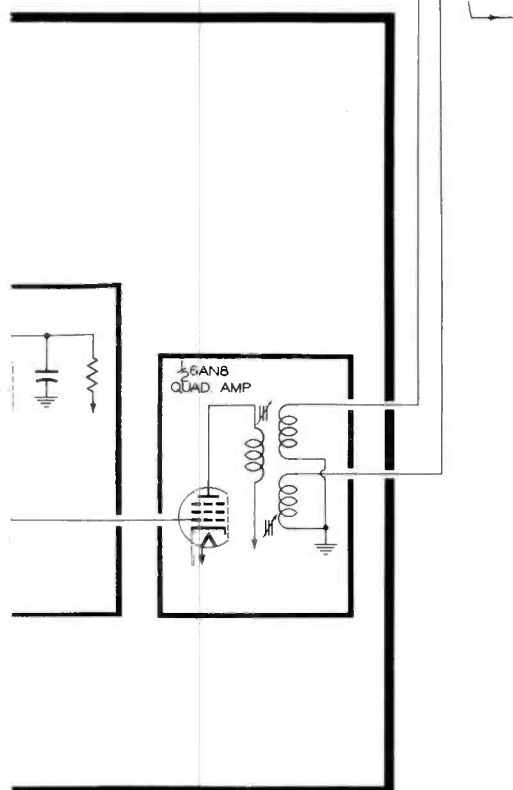

© Howard W. Sams & Co., Inc. 1954

## PHOTOFACT\* COLORBLOCK Reference Chart No. 1

A COLORBLOCK of a Receiver Which Demodulates on the I and Q Axes and Which Employs a 3.58-mc Crystal Oscillator and a Three-Gun Color Picture Tube.

Based on data submitted by Edwin N. Hauber, Arlington, Va.

PF INDEX, the Monthly REPORTER  
for the Electronic Service Industry—June, 1954.

# Performance! Profits! Packages!

GET THE BEST IN ALL 3 WITH THE NEW

## Federal SCS DIODES

GERMANIUM  
"SINGLE-CRYSTAL-STABILIZED"

Highest quality diodes for every replacement need...packed for economy buying...in the service industry's MOST USEFUL PACKAGE LINE!

Servicemen! Federal's "S-C-S" Germanium Diode Packaging Program is the hottest news in diode purchasing!

You get top performance and attractive profits in handy packages you can use for many practical purposes.

You can buy single units in cellophane-wrapped packages . . . you can buy 5-unit and 10-unit packages in the form of clear plastic cases with hinges and snap-lock. You can buy boxes of 50 single-unit packages . . . at a substantial saving!

### Look for "S-C-S" Diodes in Federal's Store Dispensers!

When you're shopping at your Federal Distributor - look for these two types of dispensers: (A) counter dispenser with single-, five- and ten-unit packages; (B) wall dispenser with single-unit packages. Serve yourself . . . save time! Watch for them in stores . . . in golden yellow and brilliant red!



**10-UNIT PACKAGE**  
—economy-size clear plastic hinged utility case.



**5-UNIT PACKAGE**  
—clear plastic hinged utility case.



**SINGLE-UNIT PACKAGE**  
—cellophane-wrapped.



**50-UNIT PACKAGE**  
—large-economy-size, combination dispenser-container . . . a real money-saver!



**CHECK** the quality and performance features of Federal's new design achievement in diodes! You'll agree that Federal is your best bet for profitable, customer-satisfying diode servicing!

## Federal Telephone and Radio Company

A Division of  
INTERNATIONAL TELEPHONE AND TELEGRAPH CORPORATION  
COMPONENTS DIVISION, 100 KINGSLAND ROAD, CLIFTON, N. J.  
In Canada:  
Federal Electric Manufacturing Company, Ltd., Montreal, P.Q.  
Export Distributors:  
International Standard Electric Corp., 67 Broad St., N. Y.

### Federal "S-C-S" Diodes ARE TOPS!

**SINGLE-CRYSTAL GERMANIUM**—the finest for reliable performance  
**MOISTURE-PROOF**—vacuum-sealed, all-ceramic construction  
**EVERY DIODE TESTED** for all characteristics  
**COMPLETELY INSULATED CASE**  
**POLARITY** clearly identified  
**HEAT SINKS** protect during soldering  
**SMALL SIZE** ( $\frac{1}{4}$ " diameter,  $\frac{1}{2}$ " long)  
**FLEXIBLE LEADS** for easy mounting  
**NO FILAMENT**—no heater power drain or hum  
**LOW SHUNT CAPACITY** (average 1 mmf.)  
**SELF-HEALING** for temporary overloads  
**NO CONTACT POTENTIAL**  
**WITHSTAND** adverse temperature and humidity cycling  
**INSURE** many thousands of hours of dependable performance

### PACKAGES YOU CAN USE!

Be sure to save Federal's 5-unit and 10-unit packages of clear plastic. They're hinged . . . they snap-lock . . . they open easily. Excellent for storing small parts . . . carrying in pocket or kit or filing in shop cabinets. They're a plus value you get with Federal quality-controlled "S-C-S" Diodes!

Ask your Federal Distributor or write to Dept. R-3118

When the profile of the Cadillac looked like this



It was understandable that the profile of a V.O.M. might look like this



But this is the profile of today's Cadillac



And if you buy a V.O.M. that is truly of today it will have a profile like this



## STREAMLINING signifies the difference!

In cars, streamlining symbolizes the tremendous advances in automotive engineering and performance. In fine test equipment, too, streamlining signifies the difference.

The flush switches, dials and jacks of the Smoothie make it easy to slip in your pocket, carrying case or tool kit, eliminate snag hazards on your bench.

But even more—the streamlining expresses externally the advanced internal design which makes the Triplett Model 630 as superior to the obsolete knobby bumpy-faced testers as the Cadillac of today is to the Cadillac of fifty years ago. These internal design features include such developments as selector switch of molded construction, completely enclosed; elimination of harness wiring, etc. Your most frequently used tester—your V.O.M.—should be the best—the one of which many thousands are in use in laboratories today—the Smoothie, Triplett Model 630 Volt-Ohm-Mil-Ammeter, \$39.50 net. Ask your parts jobber or write Triplett Electrical Instrument Company, Bluffton, Ohio.

Only Triplett offers you a ten day free trial on all test equipment.

# the SMOOTHIE

the only streamlined V.O.M. with a smooth face

TRIPLETT  
630

Volt-Ohm-Mil-Ammeter



When the profile of the Cadillac looked like this



It was understandable that the profile of a V.O.M. might look like this



But this is the profile of today's Cadillac



And if you buy a V.O.M. that is truly of today it will have a profile like this



## STREAMLINING signifies the difference!

In cars, streamlining symbolizes the tremendous advances in automotive engineering and performance. In fine test equipment, too, streamlining signifies the difference.

The flush switches, dials and jacks of the Smoothie make it easy to slip in your pocket, carrying case or tool kit, eliminate snag hazards on your bench.

But even more—the streamlining expresses externally the advanced internal design which makes the Triplet Model 630 as superior to the obsolete knobby bumpy-faced testers as the Cadillac of today is to the Cadillac of fifty years ago. These internal design features include such developments as selector switch of molded construction, completely enclosed; elimination of harness wiring, etc. Your most frequently used tester—your V.O.M.—should be the best—the one of which many thousands are in use in laboratories today—the Smoothie, Triplet Model 630 Volt-Ohm-Mil-Ammeter, \$39.50 net. Ask your parts jobber or write Triplet Electrical Instrument Company, Bluffton, Ohio.

Only Triplet offers you a ten day free trial on all test equipment.

# the SMOOTHIE

the only streamlined V.O.M. with a smooth face

TRIPLET

630

Volt-Ohm-Mil-Ammeter



# COLORBLOCK

## Chart No. 1

### COLOR TRANSMISSION STANDARDS

#### 8. Frequency Distribution of the Color Signal

1. Horizontal-scanning frequency = 15,734.264 cps.
2. Vertical-scanning frequency = 59.94 cps.
3. Color subcarrier and burst frequency = 3.579545 mc.
4. ERP of aural transmitter must not be less than 50% nor more than 70% of visual ERP.
5. Equations of signals involved in color transmission:

- (a)  $E_Y = 0.30E_R + 0.59E_G + 0.11E_B$
- (b)  $E_R - E_Y = 0.70E_R - 0.59E_G - 0.11E_B$
- (c)  $E_B - E_Y = -0.30E_R - 0.59E_G + 0.89E_B$
- (d)  $E_G - E_Y = -0.30E_R + 0.41E_G - 0.11E_B$  (not transmitted as such)
- (e)  $E_I = -0.27(E_B - E_Y) + 0.74(E_R - E_Y)$
- (f)  $E_Q = 0.60E_R - 0.28E_G - 0.32E_B$
- (g)  $E_Q = 0.41(E_B - E_Y) + 0.48(E_R - E_Y)$
- (h)  $E_Q = 0.21E_R - 0.52E_G + 0.31E_B$
- (i)  $E_M = E_Y + [E_Q \sin(\omega t + 33^\circ) + E_I \cos(\omega t + 33^\circ)]$
- (j) For color-difference frequencies below 500 kc,  

$$E_M = E_Y + \frac{1}{1.14} [1.78(E_B - E_Y) \sin \omega t + (E_R - E_Y) \cos \omega t]$$

6. Hue determines the phase of the color subcarrier.
7. Saturation determines the amplitude of the color subcarrier.

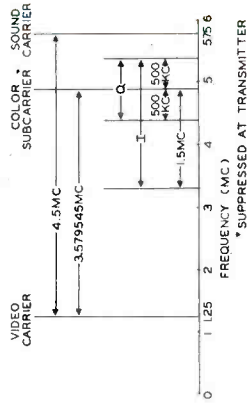

#### 9. Color-Burst Specifications

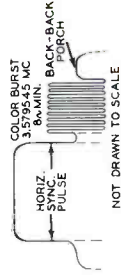

#### 10. Color Phase Diagram

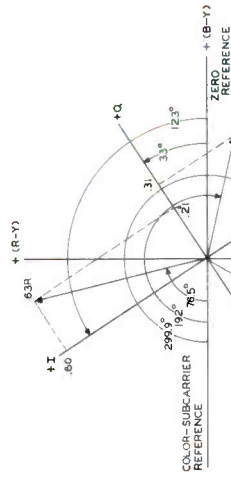

### MATRIX

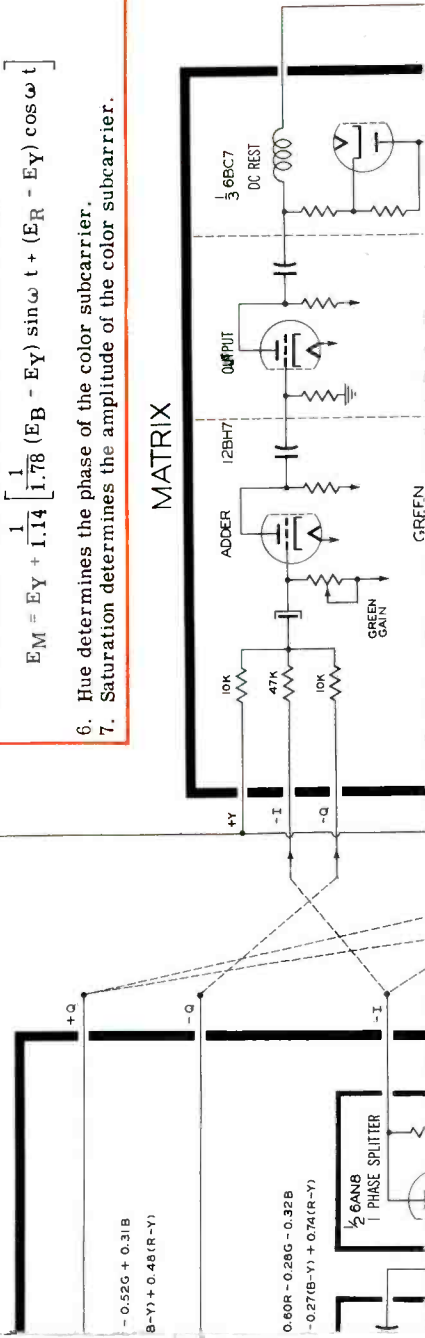
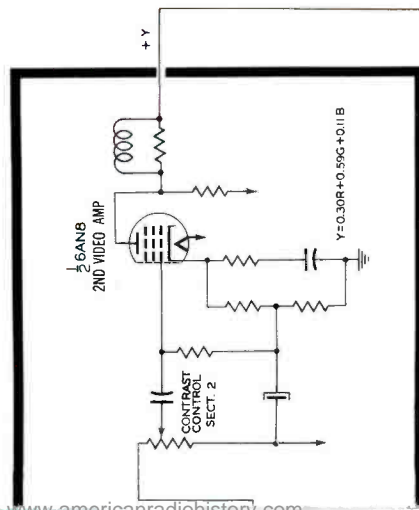

### MATRIX

The purpose of the matrix is to combine



LUMINANCE CHANNEL

The luminance channel amplifies and properly delays the composite color signal which is available from the video detector. The output of this channel is the Y signal which is fed to the matrix. The Y or luminance signal is such that it produces only brightness variations on the screen. For black-and-white transmissions, only the Y channel furnishes a signal to the matrix.

CHROMINANCE CHANNEL

The chrominance channel passes frequencies contained in the composite color signal between 2 and 4.4 mc. The take-off point for this signal is in the cathode circuit of the first video amplifier. After it is filtered, the signal is fed to the I and Q demodulators where it is demodulated by synchronous detector action. Two CW signals of the proper phase are fed to the demodulators in order to accomplish the detection. The outputs of these demodulators are minus-I and minus-Q signals which are then fed to phase splitters to produce plus and minus signals of both I and Q. These signals are coupled to the matrix where they are mixed in proper proportions with the Y signal.

A bias voltage from the color killer cuts off the bandpass amplifier during black-and-white reception.

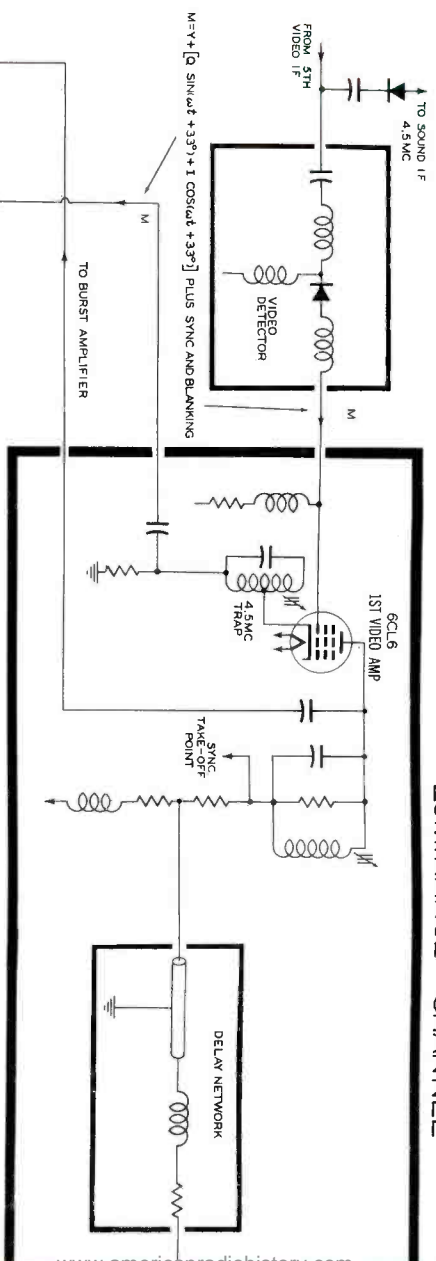

LUMINANCE CHANNEL

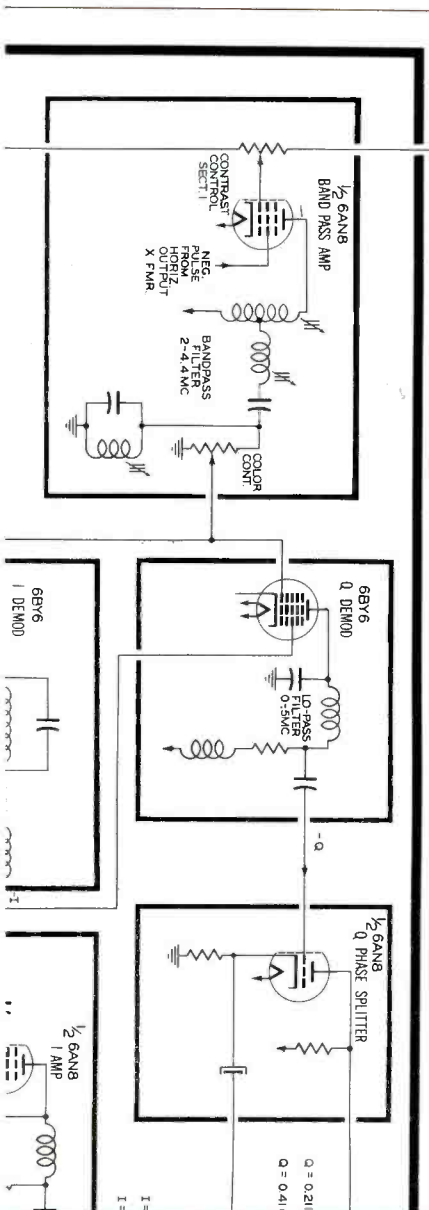

CHROMINANCE CHANNEL

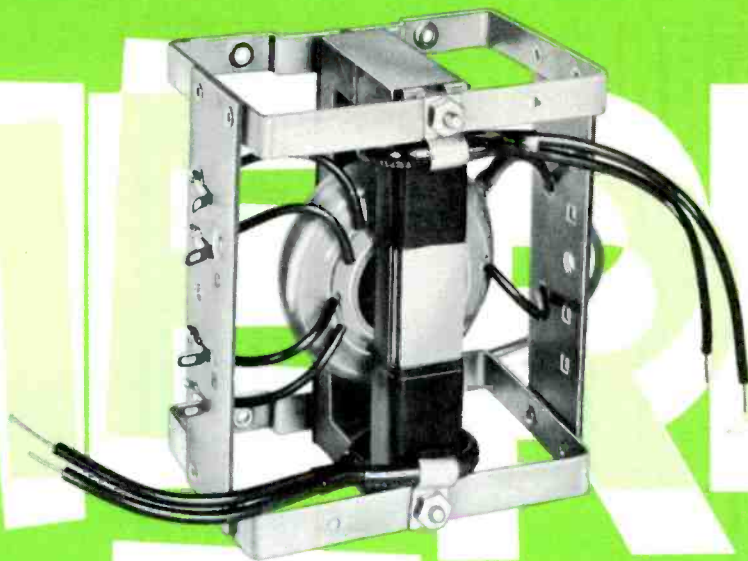

**WATCH MERIT FOR EXACT F**

**AS IT HA**

Burton brown advertising

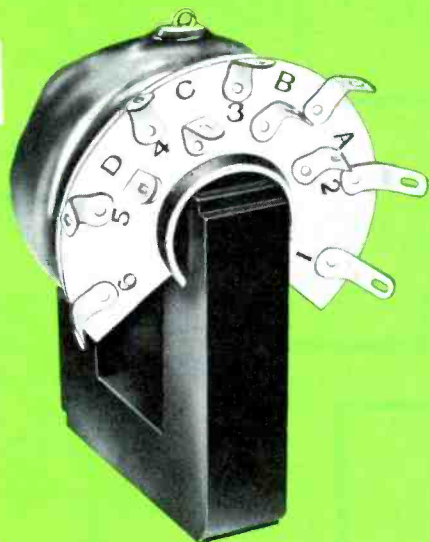

**MERIT**—the only transformer line designed exclusively for service—will be on the spot with exact replacements for color television.

Since 1947 Merit has made available to you a complete line of replacement transformers including such exact replacement requirements as Merit Model HVO-13 for Sylvania, Model HVO-16 for Philco and Model HVO-23 for Admiral.

Merit's three plants in Chicago, Hollywood, (Calif.) and Hollywood (Fla.) are geared to supply your replacement transformer needs when you need them wherever you are.

# REPLACEMENT IN COLOR TV S BEEN IN BLACK & WHITE TV SINCE 1947



**MERIT COIL & TRANSFORMER CO.**  
4427 N. Clark Street, Chicago 40, Illinois

## COLOR KILLER

The purpose of the color killer is to disable the chrominance channel during black-and-white reception. The operation of this stage is dependent upon a positive pulse from the horizontal-output transformer and upon a bias voltage from the phase detector. The voltage developed in the plate circuit of the color killer is coupled to the bandpass amplifier for biasing purposes. During color reception, the presence of the color burst results in a negative voltage being developed at the phase detector. This voltage biases the color killer to cutoff and thus permits normal operation of the band-pass amplifier.

During black-and-white reception, no color burst is present. The color killer conducts and produces a negative voltage in its plate circuit. This voltage cuts off the bandpass amplifier and disables the chrominance channel.

## COLOR SYNCHRONIZATION

The purpose of the color-synchronizing section involves the generation of two CW signals which have a fixed relationship to the color-burst signal with respect to frequency and phase. These CW signals are fed to the I and Q demodulators for the purpose of demodulating the color signal.

The input signal consists of the composite color signal and is fed to a burst amplifier which, in combination with a keyer, allows only the color burst to pass. A 3.58-mc crystal oscillator is regulated by a phase detector and reactance tube combination so that it operates at the same frequency as the color burst and with a specific phase relationship to the burst. A quadrature amplifier and phase-shifting network then produce two 3.58-mc signals — one with a phase of -57 degrees with respect to the color burst, the other with a phase of -147 degrees.

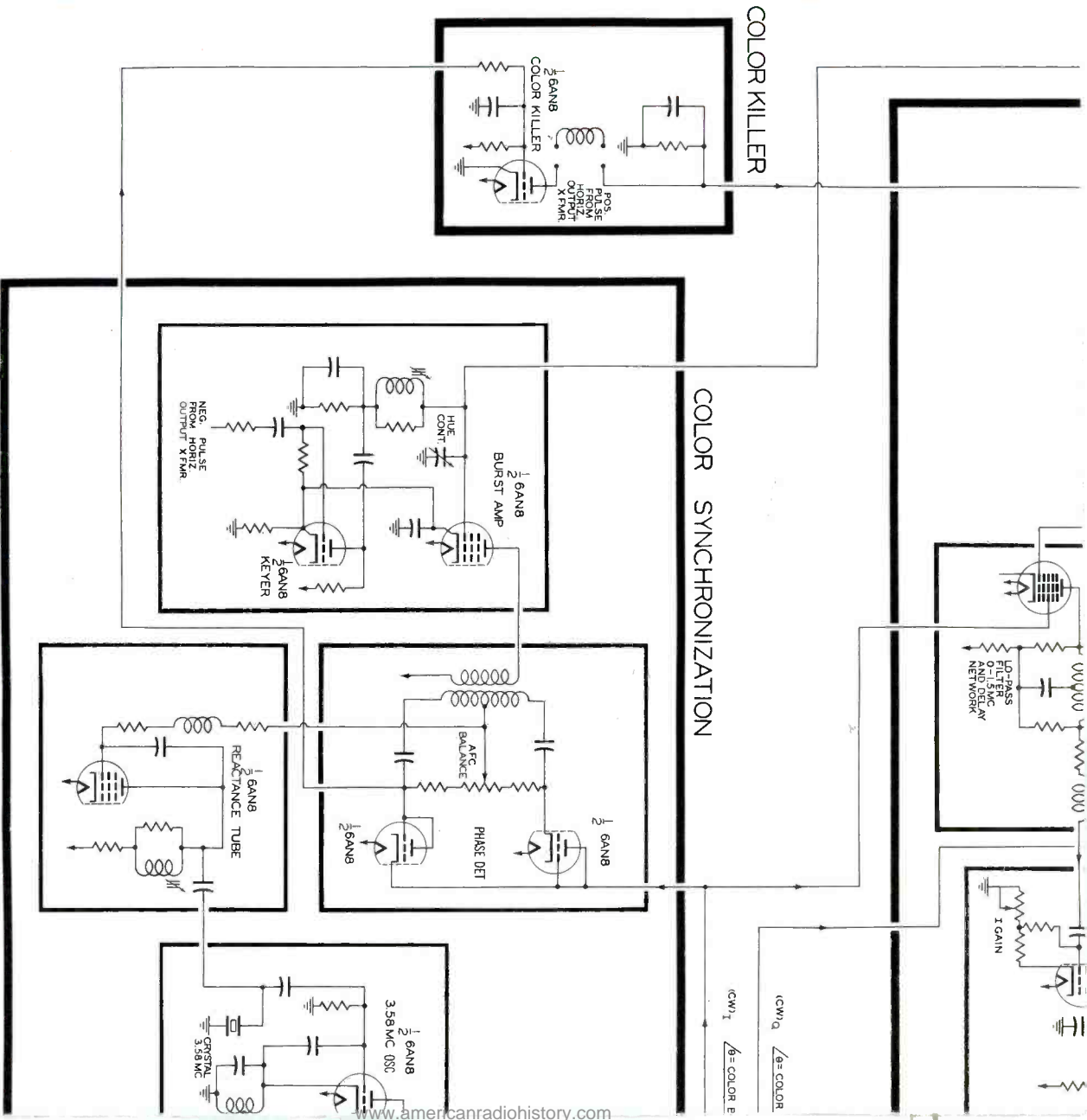

and amplify the Y, I, and Q signals in the proper proportions to produce three signals representative of the three color signals at the camera. These signals are applied to the three guns in the color picture tube and result in the reproduction of the desired color picture.

The inputs to the matrix consist of a Y signal and both plus and minus polarities of the I and Q signals. The gain of the green and blue channels in the matrix can be varied to provide proper balance in the three channels. DC restoration is provided in each channel.

### BEAM CONTROL

1. BEAM-POSITIONING MAGNETS orient individual beams so that they may be made to strike the shadow mask at the proper point and at the correct angle.
2. The PURIFYING COIL acts to align all three beams so that they strike their respective phosphor dots.
3. The FOCUS ELECTRODE in the gun structure is provided with AC and DC voltages which properly focus the beams at all points on the screen.
4. The CONVERGENCE ELECTRODE in the gun structure is provided with AC and DC voltages which properly converge the beams at all points on the shadow mask.
5. The FIELD NEUTRALIZING COIL and ANTI-MAGNETIC SHIELDS about the tube counteract the influence of external magnetic fields.

## PHOTOFACT\* COLORBLOCK Reference Chart No. 1

A COLORBLOCK of a Receiver Which Demodulates on the I and Q Axes and Which Employs a 3.58-mc Crystal Oscillator and a Three-Gun Color Picture Tube.

Based on data submitted by Edwin N. Hauber, Arlington, Va.

PF INDEX, the Monthly REPORTER  
for the Electronic Service Industry—June, 1954.

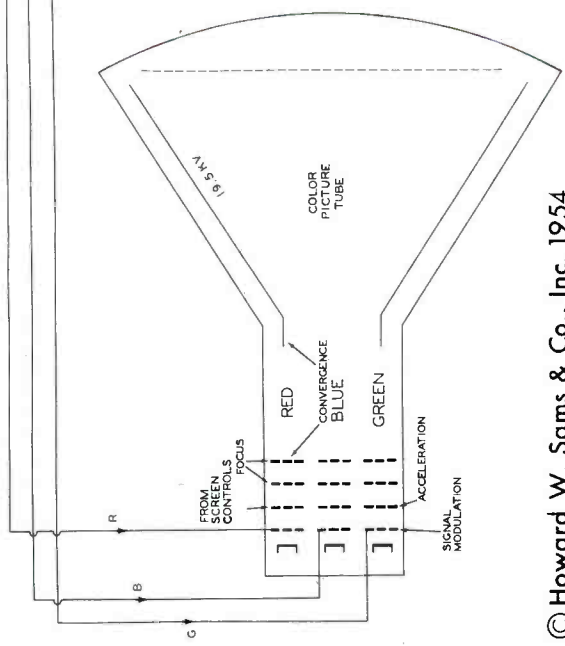
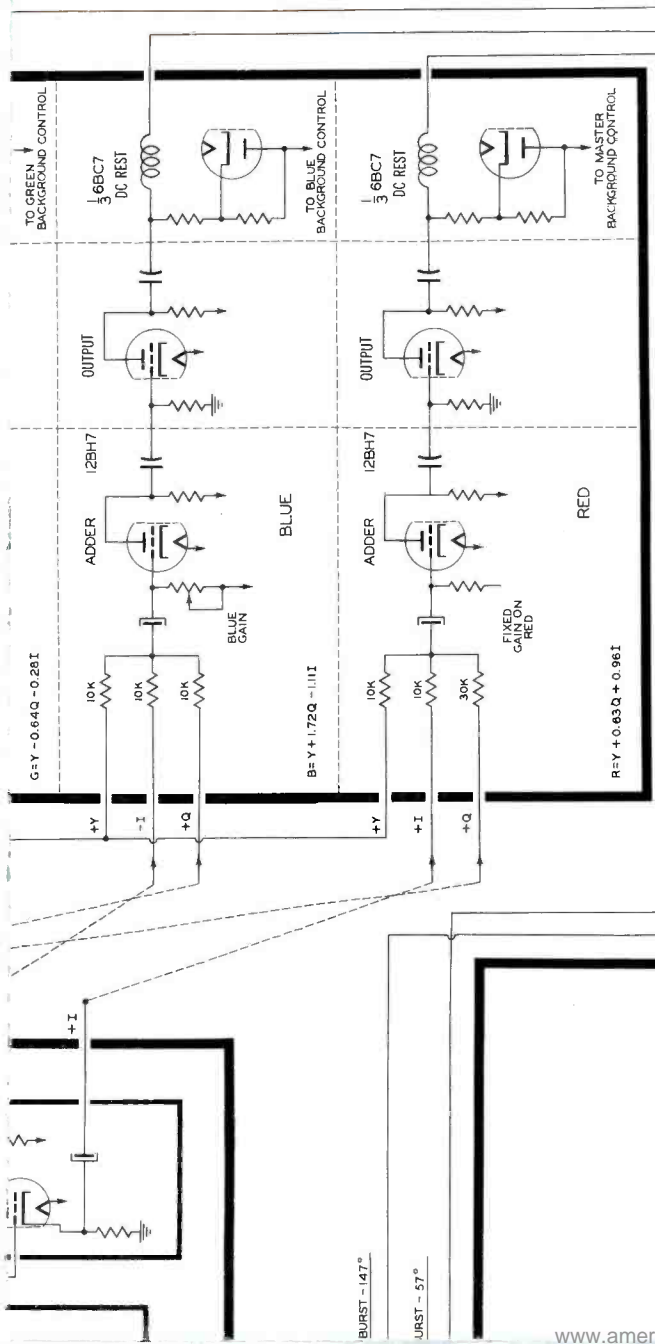

© Howard W. Sams & Co., Inc. 1954

# Performance! Profits! Packages!

## GET THE BEST IN ALL 3 WITH THE NEW

# Federal **S·C·S** GERMANIUM DIODES



**Highest quality diodes for every replacement need...packed for economy buying...in the service industry's MOST USEFUL PACKAGE LINE!**

Servicemen! Federal's "S-C-S" Germanium Diode Packaging Program is the hottest news in diode purchasing!

You get top performance and attractive profits in handy packages you can use for many practical purposes.

You can buy single units in cellophane-wrapped packages . . . you can buy 5-unit and 10-unit packages in the form of clear plastic cases with hinges and snap-lock. You can buy boxes of 50 single-unit packages . . . at a substantial saving!

### Look for "S-C-S" Diodes in Federal's Store Dispensers!

When you're shopping at your Federal Distributor — look for these two types of dispensers: (A) counter dispenser with single, five- and ten-unit packages; (B) wall dispenser with single-unit packages. Serve yourself . . . save time! Watch for them in stores . . . in golden yellow and brilliant red!

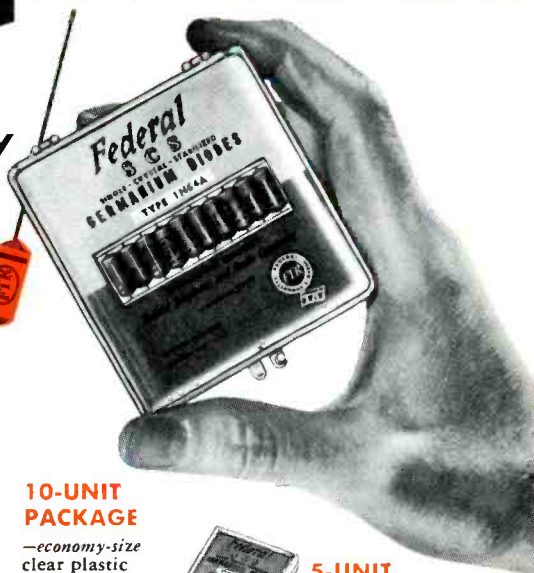
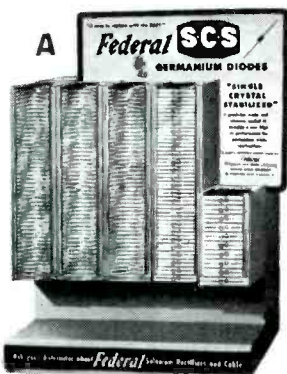

#### 10-UNIT PACKAGE

—economy-size clear plastic hinged utility case.

#### 5-UNIT PACKAGE

—clear plastic hinged utility case.



#### SINGLE-UNIT PACKAGE

—cellophane-wrapped.



#### 50-UNIT PACKAGE

—large-economy-size, combination dispenser-container . . . a real money-saver!



**CHECK** the quality and performance features of Federal's new design achievement in diodes! You'll agree that Federal is your best bet for profitable, customer-satisfying diode servicing!

# Federal Telephone and Radio Company

A Division of  
INTERNATIONAL TELEPHONE AND TELEGRAPH CORPORATION  
COMPONENTS DIVISION, 100 KINGSLAND ROAD, CLIFTON, N. J.  
In Canada:  
Federal Electric Manufacturing Company, Ltd., Montreal, P.Q.  
Export Distributors:  
International Standard Electric Corp., 67 Broad St., N. Y.

### Federal "S-C-S" Diodes ARE TOPS!

**SINGLE-CRYSTAL GERMANIUM**—the finest for reliable performance  
**MOISTURE-PROOF**—vacuum-sealed, all-ceramic construction  
**EVERY DIODE TESTED** for all characteristics  
**COMPLETELY INSULATED CASE**  
**POLARITY** clearly identified  
**HEAT SINKS** protect during soldering  
**SMALL SIZE**—(1/4" diameter, 1/2" long)  
**FLEXIBLE LEADS** for easy mounting  
**NO FILAMENT**—no heater power drain or hum  
**LOW SHUNT CAPACITY** (average 1 mmf.)  
**SELF-HEALING** for temporary overloads  
**NO CONTACT POTENTIAL**  
**WITHSTAND** adverse temperature and humidity cycling  
**INSURE** many thousands of hours of dependable performance

### PACKAGES YOU CAN USE!

Be sure to save Federal's 5-unit and 10-unit packages of clear plastic. They're hinged . . . they snap-lock . . . they open easily. Excellent for storing small parts . . . carrying in pocket or kit or filing in shop cabinets. They're a plus value you get with Federal quality-controlled "S-C-S" Diodes!

Ask your Federal Distributor or write to Dept. R-3118

Here's the most terrific Time and  
Trouble saver you've ever seen  
the **CLASSY CHASSIS CARRIER!**

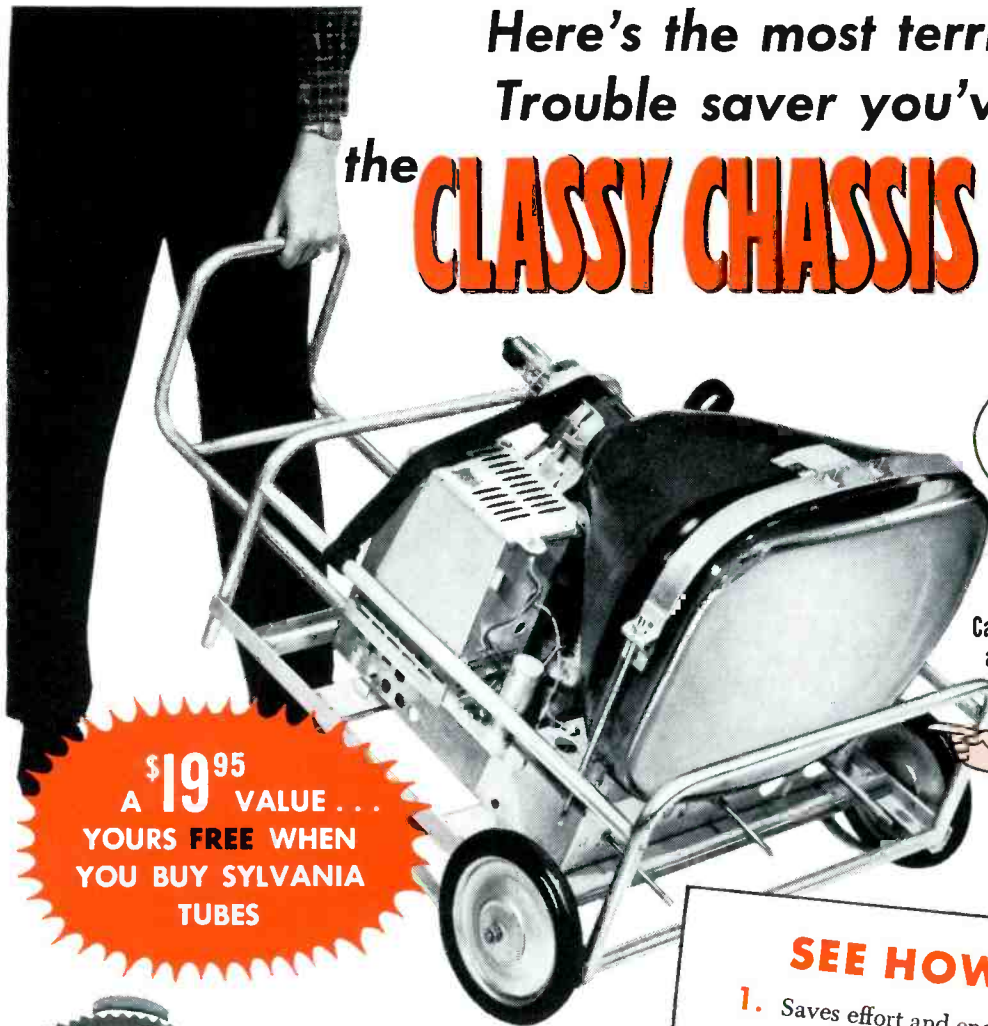

TAKES MOST OF  
THE LIFT AND LUG FROM  
TV REPAIR WORK!

Carries up to 27" tube  
and chassis easily!

**\$19<sup>95</sup>**  
A **VALUE . . .**  
**YOURS FREE WHEN**  
**YOU BUY SYLVANIA**  
**TUBES**



THE GREATEST  
WORK-SAVER EVER  
OFFERED TO SERVICE  
DEALERS!

- SEE HOW IT SAVES!**
1. Saves effort and energy . . . a breeze to wheel . . . a snap to carry!
  2. Saves extra steps and extra labor. Carries your TNT Kit . . . everything all at once.
  3. Saves valuable service time . . . permits more calls per day . . . you make more money.
  4. Prevents damage to tubes, wiring and set.
  5. Prevents damage to customers' furniture, woodwork and floors.

You'll say it's stupendous . . . the greatest and most valuable helper a TV Serviceman ever had!

An easy-wheeling, aluminum carrier that lets you move a heavy TV chassis (up to 27-inch tube) anywhere . . . with no lugging, no straining, no bumping. And no risk to tubes, floors, or polished surfaces. You save time, save money, save effort, and win renewed confidence from your customers.

**Yours FREE!**

This sensational work-saver now yours FREE with your purchases of Sylvania Tubes.

But don't delay! Offer expires August 31st. So, order your Sylvania Tubes and get your carrier reservation in NOW! Call your Sylvania Distributor for full details *today!*

SYLVANIA ELECTRIC  
PRODUCTS INC.  
1740 BROADWAY  
NEW YORK 19, N. Y.

**SYLVANIA**



In Canada:  
Sylvania Electric  
(Canada) Ltd.  
University Tower Bldg.  
St. Catherine St.  
Montreal, P. Q.

**LIGHTING • RADIO • ELECTRONICS • TELEVISION**

# LITTELFUSE

protects the **FIRST**  
*Admiral* color TV set



Burton Brown Advertising

**LITTELFUSE, Inc., Des Plaines, Illinois**