

# PICK-UPS

M A Y 1 9 4 2



Western Electric Radio Equipment Serves  
United Nations on Land, Sea and in the Air



# PICK-UPS

MAY, 1942

BEING A PERIODICAL DEVOTED TO DEVELOPMENT IN SOUND TRANSMISSION. PUBLISHED BY THE

**Western Electric**  
C O M P A N Y

195 Broadway : New York, N. Y.

C. G. STOLL . . . . . President  
H. B. GILMORE . . . . . Secretary  
G. B. PROUD . . . . . Treasurer

WILL WHITMORE, Editor

M. M. BEARD, VANCE HILLIARD  
Assistant Editors

Pick-Ups does not accept responsibility for quoted statements appearing in the magazine. Such statements reflect only the opinions of the person quoted.

Copyright, 1942  
by Western Electric Company, Incorporated

Photographs appearing on the cover were supplied by the Army and Navy Departments.

## THIS ISSUE

	Page
Western Electric War Production Zooming . . . . .	3
Western Electric War Job in Pictures . . . . .	4-9
How to Increase Tube Life . . . . .	10
WHN Goes 50 KW . . . . .	12
What's Happened to Rectifier Tube Costs? . . . . .	14
On an Island Built to Order WIOD Installs a 5 KW Transmitter . . . . .	15-17
W7INY, New York, N. Y. . . . .	18
Radio Goes to War . . . . .	20-21
Radio and Sound Equipment . . . . .	22
Is College Training in Broadcasting Worthwhile? . . . . .	24
Milestones in Radio Progress — Stabilized Feedback . . . . .	30
Western Electric Man Cited by Navy for Work at Pearl Harbor . . . . .	38

# What are we fighting for?

**T**HE VICTORY we're fighting for is to guarantee our way of life — the life we have known in the past — the broader, richer life we have visioned for the future. Inherent in this way of life is LIBERTY — liberty of thought, liberty of action.

The right to choose a vocation and to train oneself for that vocation is part of man's individual liberty. To those of us who have made that choice and are now carrying on the job selected it seems almost incredible that such liberty is threatened. BUT IT IS THREATENED — and only our complete victory will remove that threat.

One of the chief characteristics of a radio engineer is his love for his job. He thinks it — talks it — works at it even in off hours. The young man who has decided to make radio his vocation and is now in service is, among other things, fighting for the right to be a radio engineer some day. That in itself is worth fighting for.

When this war is won and we have removed every threat to our liberty of action, radio is going to be greater than our wildest dreams can make it now. No one knows just how far radio is going in the years of peace to come. Today, much is said about the future expansion of aviation and rightly so. But the instrument which will make aviation's further progress possible is radio. The vacuum tube is destined to become the outstanding controlling medium in our coming mechanistic world.

Let us remember, those of us who have made radio our vocation or plan to do so, that we are fighting for a new world of liberty and progress and adventure so breath-taking that not even the greatest minds of today can envision it. It's worth fighting for, this new world which begins the day peace is won.

★ ★ ★

**J**UST as many engineers, called to the colors, have for the time being given up their broadcasting jobs, so Western Electric, likewise called to the colors, has temporarily put aside most of its commercial broadcasting work and is devoting its huge manufacturing resources to military needs. These needs are tremendous. Radio

and sound power equipment for thousands of planes, thousands of tanks — for battleships, cruisers, destroyers, submarines, torpedo boats — for vast forces on land — must be supplied and supplied as quickly as is humanly possible.

New plants, new machinery, new employees by the hundreds, are helping to speed the Company's war production effort. To tell the whole story of how the job is being done would require many more pages than this magazine allows. Much of the work is necessarily shrouded in secrecy and must remain so until the war is over. However, some idea of the magnitude of operations, of the expert craftsmanship required in building each tiny unit, may be gleaned from the opening story and photographic review presented in this issue of PICK-UPS.

★ ★ ★

**R**EVERTING to Radio's future developments and all that future promises, brings up another important question. What is being done to train efficient staffs for broadcasting stations who will help build the great radio industry of tomorrow? In a survey of universities and colleges, networks and stations, PICK-UPS obtained some interesting facts and figures which show what is being done along these lines and what must still be done to insure broadcasting's success in days to come. Results of the survey will be found on Page 24.

★ ★ ★

**F**ROM the numerous letters we have received we know that many of PICK-UPS' readers have missed its more or less quarterly appearance since last May. The reason no issue has appeared since then is simply that we felt there was more important work to be done. Work on this present issue has been sandwiched in between jobs which had to be done. We hope there will be other issues from time to time, but if they do appear you may be sure the work involved will not have been carried on at the expense of anything more important to winning the war.

# Western Electric War Production ZOOMING



## Company Supplying Vast Quantities of Communications Equipment for Planes, Ships, Tanks and Ground Forces

**S**WITCHING from National Defense to war found the Western Electric Company swinging into production on a gigantic scale. For months past the manufacture and shipment of vital communications materials have been going forward with growing momentum. Plant facilities have been expanded, additional machinery installed, and new hands manipulating new tools are helping to step up the vast industrial war effort.

Months ago when the National Defense program went into effect plans were set in motion to safeguard buildings, machinery and products against possible sabotage and espionage. Now, with the declaration of war, these precautionary measures have been redoubled. In addition, preparations have been completed for a full black-out in the event of air attacks. At the first shrill warning brightly lighted buildings will become part of the eery darkness blanketing the surrounding areas. Many extra guards have augmented those previously assigned to patrol the grounds. Well armed—ready

for any emergency—they lend a real military air to the scene.

Few visitors are allowed within the gates and those who have reason to seek admittance must obtain special passes vouched for by certain company officials. It makes no difference who you are — a general in the army, Mayor LaGuardia, a typewriter repair man or a Western Electric employee from another location — all come under the same rigid regulations.

Before entering the grounds all persons must present credentials. As the guard at the gate scrutinizes you and your pass you feel ridiculously guilty. You know you are as innocent as a lamb, yet you have the dreadful suspicion that the ink in your fountain pen has suddenly turned to TNT. The old time courtesy is there, but the old-time open-house welcome has been packed away in moth balls.

When you finally reach the building to be visited, you find that a special badge is necessary to enter that inner sanctum — the manufacturing area. This badge bears a number which must

be checked off when you are checked out. Each employee has his own badge — a glossy disk — displaying his photograph and height.

Once inside the manufacturing shops you immediately realize that war time production is on in full swing. More turning wheels seem to be turning faster — more punch presses punching harder — more hammers pounding out their rhythmic choruses. Rows of wooden reels, wound with small cable roll toward the assembly lines. Tiers of long, dull, metal strips stand ready to be pressed and punched into shape. Sturdy little battery-operated trucks, painted bright orange, dart around the building claiming right of way with their shrill horns. Moving at a slower pace, heavily laden hand-trucks carrying cargoes of command set cases rumble by. Incoming raw materials — outgoing finished products flow in and out of the plant in a seemingly endless stream. The scene is one of perpetual motion — Western Electric on wheels. Spaces roomy not so long ago are piled

*(Continued on page 32)*



Training new employees is a big part of the Company's war job. Careful workmanship comes first — speed is added later. In this finger dexterity test small pins are placed in tiny holes



Another young student enters the Western Electric Vestibule School where he is given instruction in operating a drill press

Intent on her new war job this young woman is being shown the method of winding coils — the lesson is taught on a test board



Small parts from outside firms go through rigorous micro-projector tests before they are incorporated in assemblies





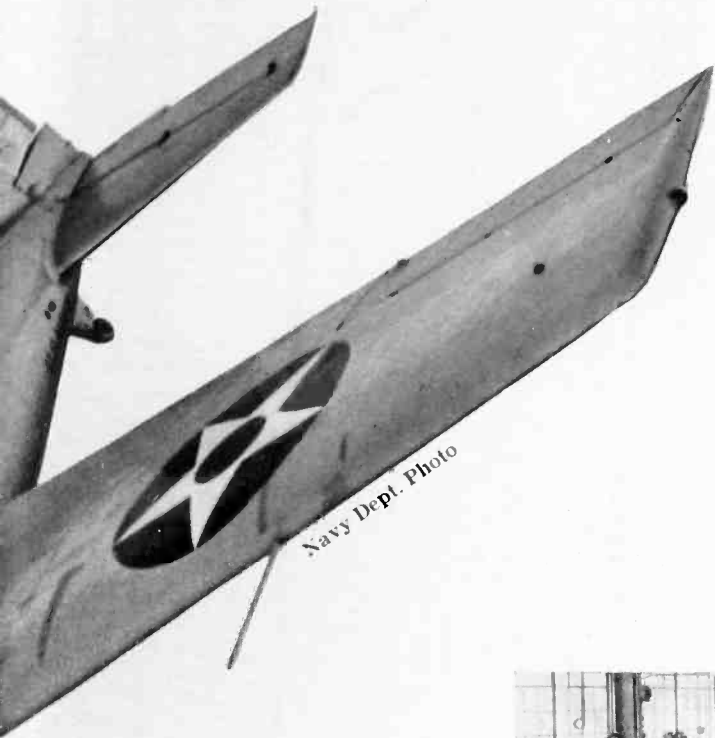

Rows of radio receivers for the Air Corps are being wired by these expert craftsmen



Tiny parts like pieces of a jigsaw puzzle rapidly grow into radio units for the U. S. Signal Corps

To supply America's mighty military machine with radio transmitters and receivers — voices and ears for fighting men and machines — is a big part of Western Electric's war job — these pages give a glimpse of how it is done

Radio chassis by the hundreds roll through the aisles of this Western Electric plant towards assembly rooms

As they assemble condensers which form part of the radio equipment for the Signal Corps these skilled workers know that precision as well as speed is the watchword

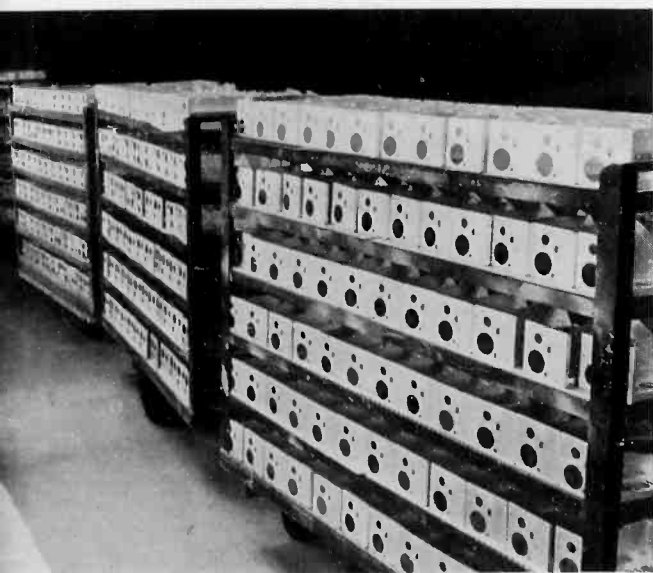

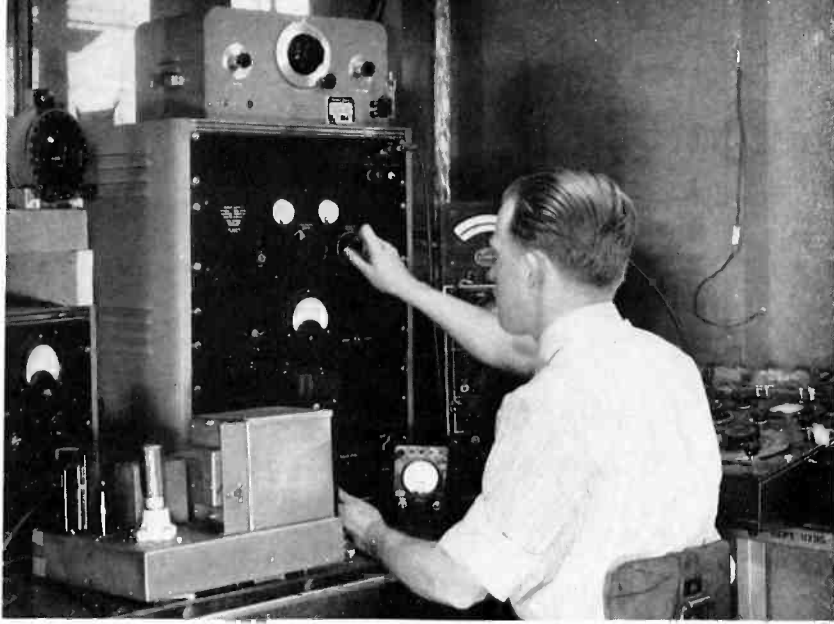

In a booth shielded from electrical interference radio equipment is tested



"Squeeze riveting" is an important operation in the manufacture of radio parts for Signal Corps equipment. The "Riveter" wears her identification badge



Before getting their enamel coatings these housings pass through dipping and shielding operations. Equipment will be installed on fighter planes.

KEEP 'EM ROLLING



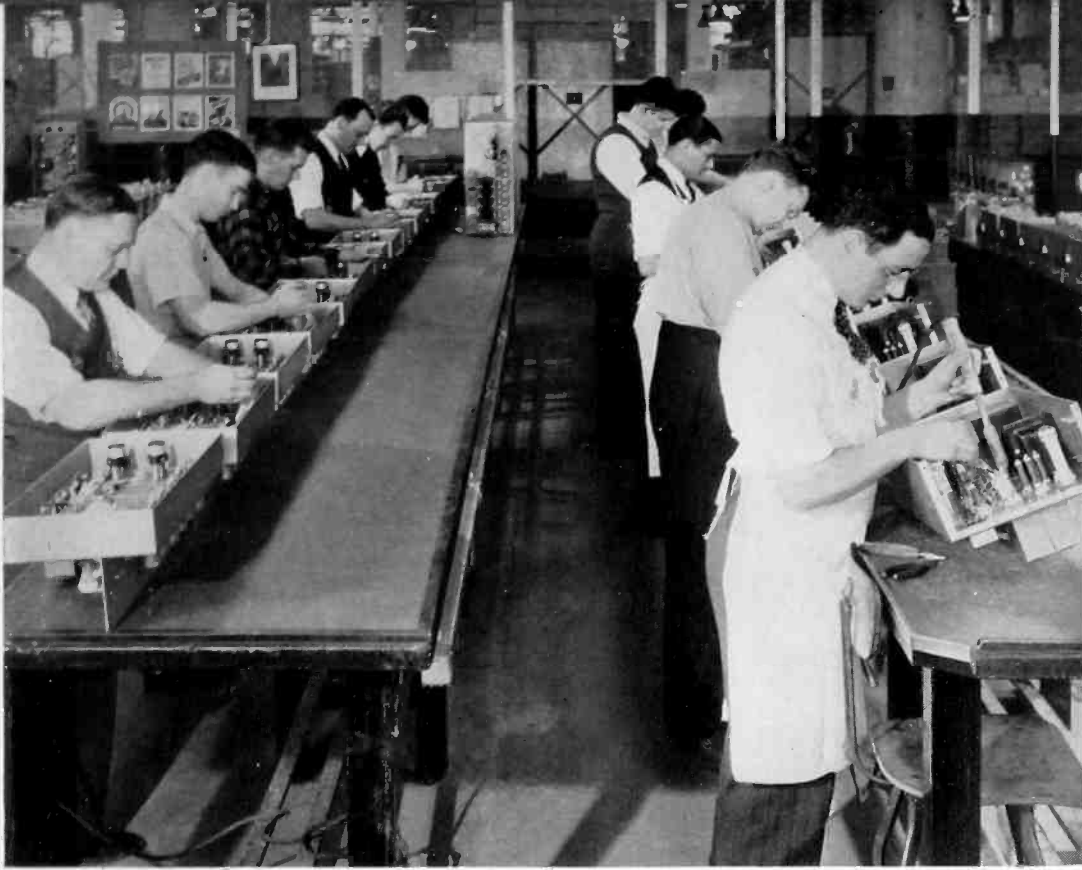

In tune with the crying need to "Keep 'em Rolling" fingers and machines are rolling vast quantities of communications equipment along assembly lines with increasing speed

Only highly skilled workers can perform the delicate job of wiring radio equipment

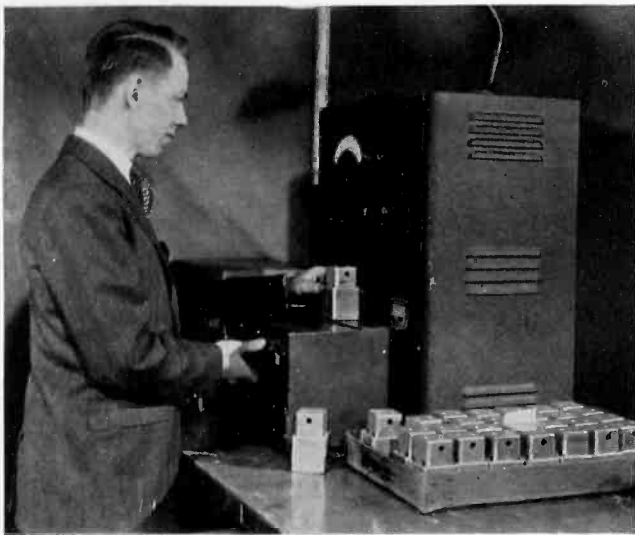

Shielded coils pass rigid tests before final assembly

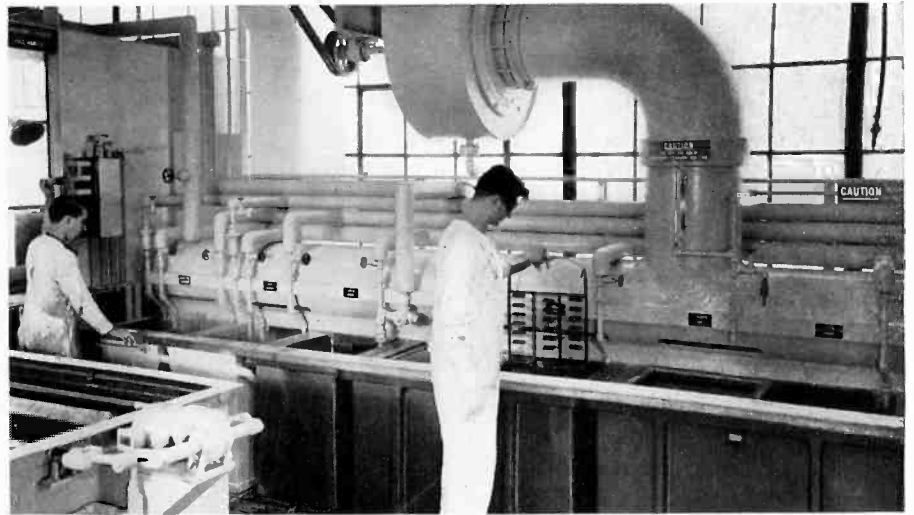

The operator at left pulls the switch that starts operations, while his co-worker dips radio parts. This is one of the new plating rooms in Western Electric plant

Two one-thousandths of an inch is the tolerance which this inspector allows on ceramic parts supplied by outside firms



Frameworks under construction which soon will house wired radio units







Height gauge and dial indicator implement the checking of radio parts to a tolerance within .0005 of an inch



A steady stream of crates and boxes filled with radio equipment are being loaded into freight cars that will carry them swiftly to their destinations

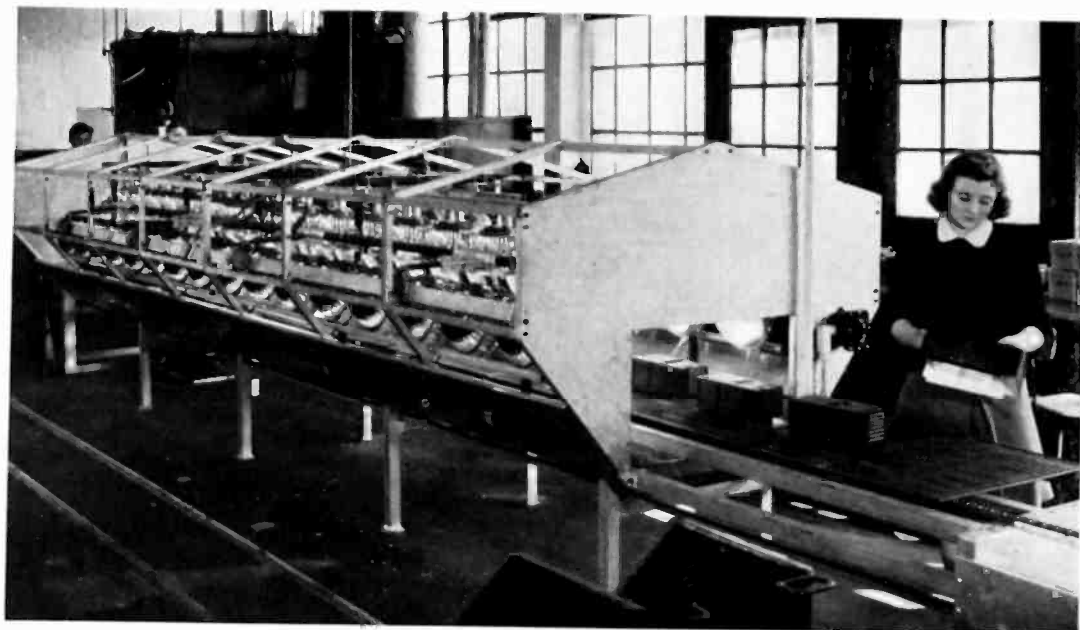

This infra-red ray tunnel chops 75 per cent off the time it ordinarily would take to bake the coating of wrinkle enamel on radio housings. The enamel is baked from the inside out

Thousands of Western Electric men and women turning out tons of radio, sound power equipment are helping to keep ships like these in the battle line

# KEEP 'EM FIGHTING

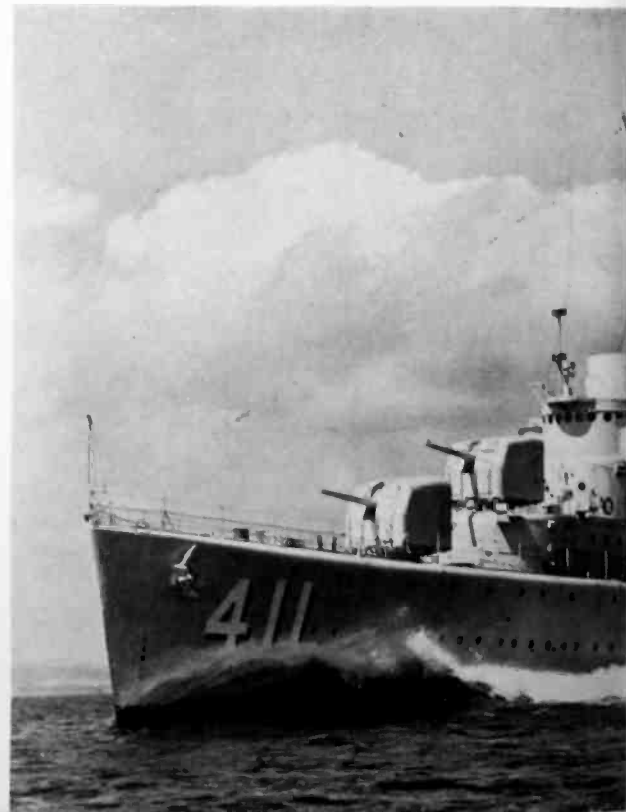



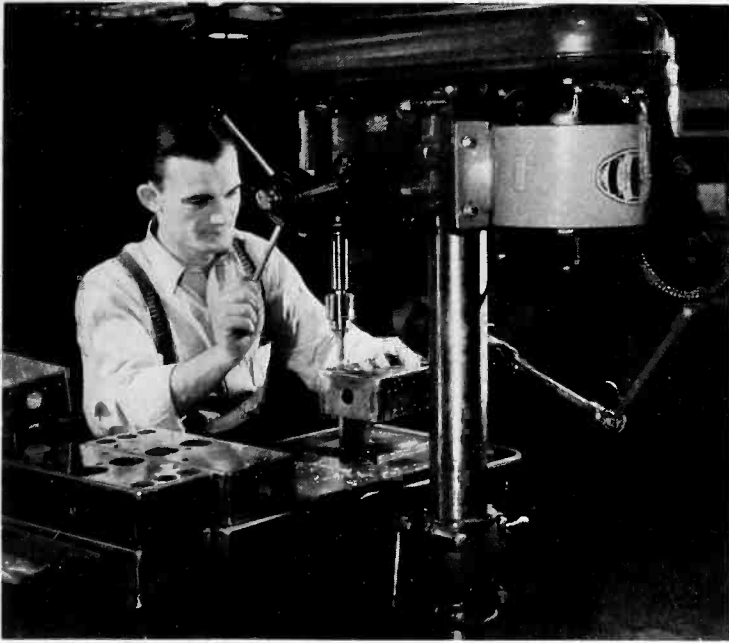

One of the country's millions of workers back of Uncle Sam's fighter and bomber planes is counterboring command set cases

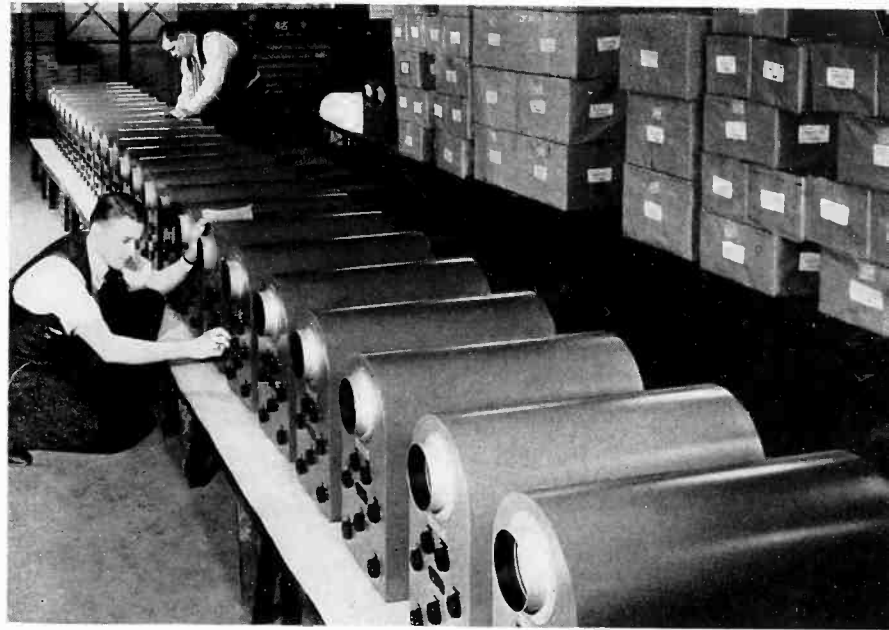

Vigilant inspection wages war against the slightest defect. In peace or war precision is an old Western Electric custom

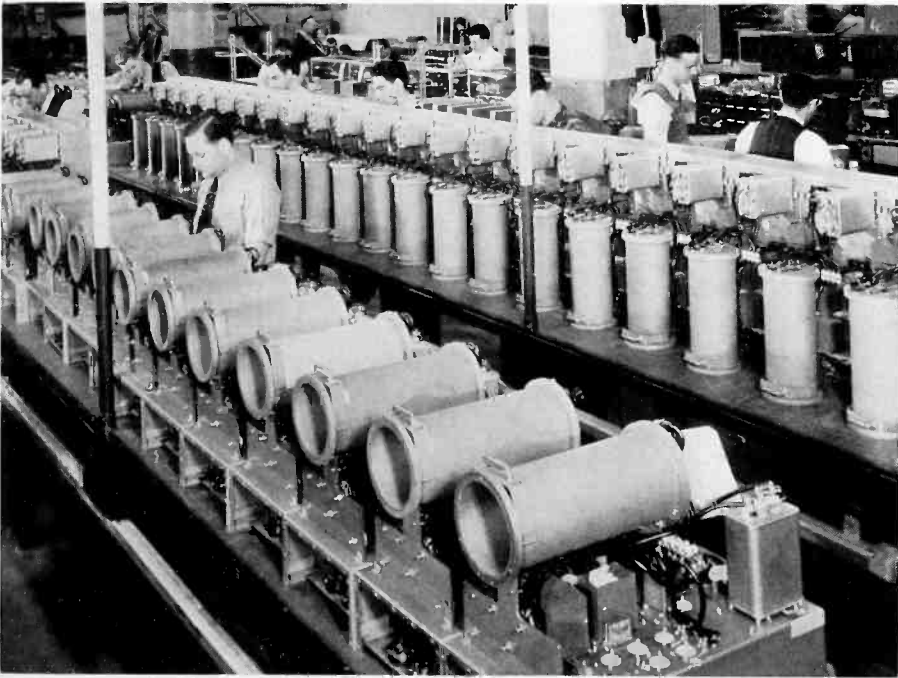

Long rows of radio units near the final steps on Western Electric assembly lines—soon they will be playing an important role in America's big battle



She's teaming up with Uncle Sam's flyers by engraving symbols on knobs of control panels

Photos Below, Navy Dept.

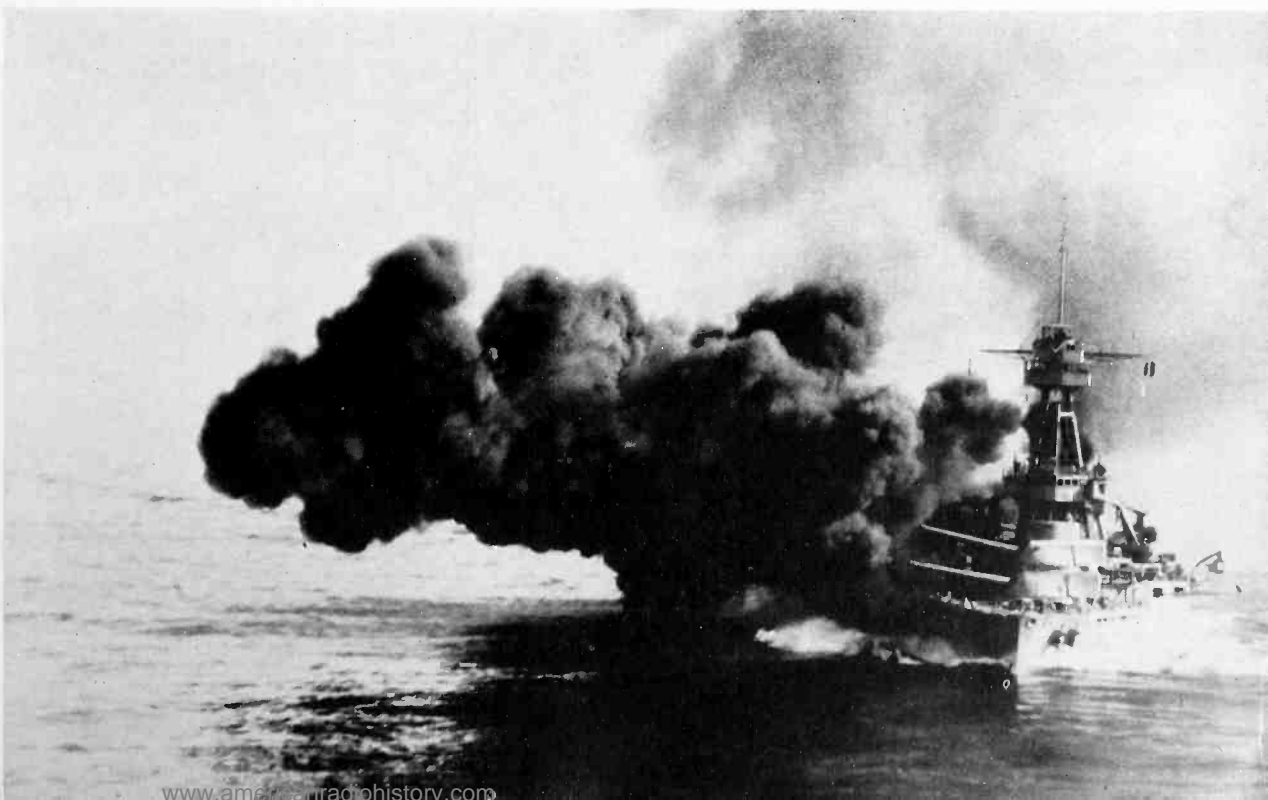

# How to Increase Tube Life

## War Shortages Call for Greater Efficiency in Operation of Vacuum Tubes to Prolong Life

(The methods of handling, storing and operating transmitter tubes and the inexpensive tube reconditioner described in Mr. Singer's article are being used successfully by WOR and its FM station W71NY.)

By **CHARLES H. SINGER**  
 Technical Supervisor  
 WOR—W71NY Transmitters

**V**ACUUM TUBES should always be treated with proper care and consideration. Today, this is essential, because war has produced a scarcity of raw materials and productive capacity for the manufacture of new tubes for commercial stations. Anything the broadcast engineer can do now to prolong tube life and still keep them operating at, or very near, peak efficiency will be a boon to his own station, the station's audience, and to the industry as a whole.

Most engineers are aware of the many factors that enter into tube life. The more important ones are:

1. Filament voltage
2. Plate voltage, residual gases
3. Fatigue of metal parts
4. Heating and cooling cycles
5. Efficiency of cooling system
6. Efficiency of transmitter, maintenance, and associated protective relays
7. Care of spares and tubes in storage

Proper precaution must be taken with each of these factors. Plotting a standard system of procedure for each will eliminate many of the abuses which may cause tubes to burn out or become inoperative long before their useful life is run.

### FILAMENT VOLTAGE

#### Tungsten Filament Tubes

When direct current is used for heating the filament, returns of the plate and grid circuits are usually connected to the positive filament terminal. Electron current return flow is through one side of the filament. If the polarity is left the same for any length of time, there will be a greater thinning of one side of the filament which can result in premature failure. Because of this, the polarity of these tubes should be reversed each week.

Correct filament voltage is of the greatest importance. The accompanying characteristic curves of a typical 10 kw triode used in a Class B linear transmitter show the important relationship between filament voltage and tube life. The rated filament voltage for this tube is 20 volts and its normal life expectancy is 13,500 hours. If filament voltage is reduced 5 per cent, filament life is doubled. Conversely, operating with a filament voltage 5 per cent above normal cuts its life nearly in half. At WOR by reducing filament voltage to 19½ volts, a reduction of 2½ per cent, the increase in life expectancy of the tube is 4,100 hours.

It follows that this reduced filament voltage will have some effect on electron emission. Modern transmitters provide a 22½ per cent increase in antenna current with full modulation, single frequency, when operated normally. Decreasing filament voltage will decrease this antenna current rise if the available filament emission is too low. The important point is — in time of

war should we sacrifice idealistic operation in order to gain longer tube life, provided it does not seriously impair listeners' reception?

A reduction in filament voltage of 5 per cent can be applied to transmitters with slight effect on peak power. In fact, peak currents equal to the total emission available may be drawn continuously without damage to the filament, if it is of the pure tungsten type. Reference to the tube manufacturer's charts will reveal data on available filament emission. On certain types, such as the Western Electric 298A, marked voltages for a fixed emission are supplied by the manufacturer.

When there is an excess amount of emission available from tungsten filament tubes, it is possible to insert dropping resistors in series with the filament leads and thus gain many hundreds of hours of additional life. In transmitters of the Western Electric 306A type, filament voltages of the second power amplifier should be dropped from 20 to 19 volts. All the emission of the tubes is definitely not needed, and tube life can be extended to approximately 30,000 hours with little or no effect on the peaks of modulation.

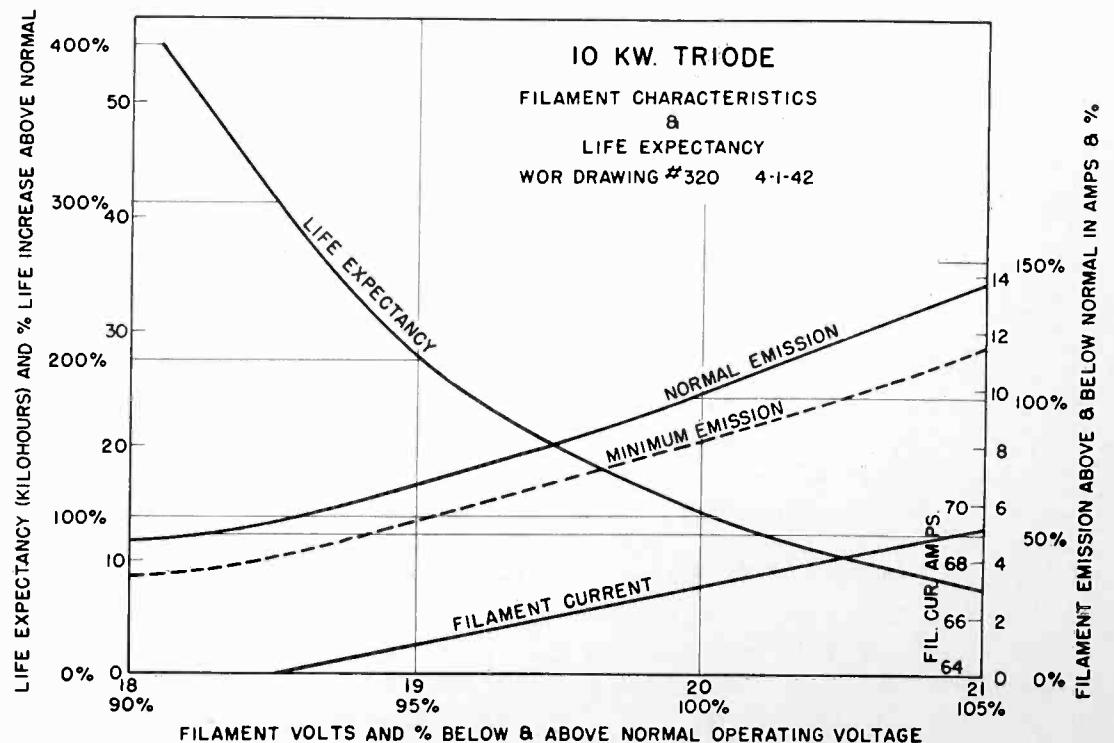



Increased transmitter distortion may result from decreased filament voltage. This should be given individual consideration, depending on the spare tubes on hand or available in times of emergency.

WOR finds it important to check the accuracy of filament and bias voltmeters each week, using a standard calibrated meter which reads voltage at the tube terminals. Zero adjustment of the filament voltmeter should be checked daily and a standard method should be used. This can be done by standing directly in front of the meter at a distance of three feet and adjusting the meter to zero. Thereafter, the meter should be read from exactly the same position.

### Thoriated Tungsten Filament Tubes

Tubes using this type of filament are being used in larger quantities than pure tungsten during these times and a severe shortage of productive capacity may result. Careful consideration should be given to filament temperature, to effect a proper balance between the loss and replacement of the thin layer of thorium on the filament surface. As a general rule, filament voltage should be kept to manufacturer's ratings, but in some cases it may be held slightly below this figure, depending on the peak currents drawn in the equipment. Manufacturers usually recommend that peak currents should be considerably less than the maximum which the filament is capable of emitting to insure long life.

A voltage check at the tube socket using a precision voltmeter is recommended each week. Gas in the tube will cause the thorium film to be carried off the filament at greater than normal rate. Proper bias and plate voltages must be maintained to prevent excess electrode dissipation. Plate voltage should be applied with care, taking the output capabilities of the tube into consideration.

In cases where a severe and prolonged overload has temporarily impaired the electronic emission of the filament, it can usually be restored to its normal condition by operating the filament at 30 per cent above normal voltage for a period of 10 minutes, followed by one or two hours of operation at normal voltage. During this rejuvenation, plate and grid voltages must be off.

### Thermionic Mercury Vapor Tubes

This tube usually operates high current with a low anode to cathode voltage drop. The oxide coated filament is designed to operate at a specific temperature. Sufficient time must be allowed for the filament to reach this temperature and also for mercury vapor pressure to become normal before the plate voltage is applied.

With good filament voltage regulation, a five minute preheat period will suffice. Filament voltage should be kept at the rated figure — never below. We believe it is good practice to operate one per cent above the rated voltage. We use a precision voltmeter to check voltages each week to get the longest service from these tubes.

### PLATE VOLTAGE, GASES

High plate voltage can seriously impair the emission of thoriated tungsten filaments, due to their sensitivity to positive ion bombardment. Residual molecules of gas, present in all tubes after evacuation, are ionized by collision with the electrons flowing to the plate. The resulting positive ions are attracted toward any element which is negative with respect to the anode. Those which strike the filament tend to destroy the thin film of thorium from which the high emission is derived. As the velocity of the ions increases at the higher plate voltages, injury to the thorium film is greater.

When adjusting emergency circuits, it is good practice to reduce plate voltage, either with a voltage control switch regulator or a series resistance in the plate circuit.

Gas in a tube is not necessarily the result of air leakage but is sometimes caused by the liberation of gas from the pores of the elements after the envelope is sealed and the tube conditioned for operation at high plate voltages.

Because of the care taken by manufacturers to remove gas before the tube is shipped, flash arcs seldom occur if the tube is put in service immediately. But with the long life of modern tubes, spares must remain on the shelf for extended periods. Those kept too long without being tested, are frequently found to be gassy when put in service.

Tubes operating at low voltages, such as required for receivers or low power amplifiers, are not generally af-

ected by gas. It is the larger, high voltage, high power tubes which tend to flash arc if allowed to remain inactive. At WOR we consider that three months of inactivity is too long a period.

Gassy conditions may also develop in a tube which has been operating in the transmitter for many thousands of hours. The exact cause of this is not clear, but the result can be seen in the continuous flash arcs which occur with the tube operating at its rated plate potential and power. However, if the tube is placed in a circuit of lower plate potential, it is definitely possible to get many more hours of service from it. This point should be considered carefully before any tube is discarded because of flash arcs.

A simple and successful method of treating gaseous tubes and instructions for building the necessary equipment will be covered later in this article.

### FATIGUE OF METALS

After long use, metal parts of tubes tend to evaporate, crystallize and become brittle. Severe shocks can cause damage which would never occur in a new tube. All tubes should be mounted and stored vertically and protected against mechanical shock or vibration. Failure to observe these precautions may cause filaments to break or cause misalignment of the elements. Water cooled rectifier and power amplifier tubes should remain in their sockets until they burn out, for the shock of removing has been known to cause serious damage.

### HEATING AND COOLING CYCLES

Alternate heating and cooling of tube elements when transmitters are started and stopped causes mechanical strains on filaments and electrode supports. Provision should be made to limit the initial filament current at starting. This can be done by inserting additional resistance in the filament circuit when voltage is first applied, or by using a transformer having sufficiently high reactance.

It is good practice to reduce filament voltage as low as possible when the filaments are lighted. Operate at minimum voltage for five minutes — then increase to normal operating voltage.

When closing down the transmitter, lower the filament voltage after

*(Continued on page 33)*

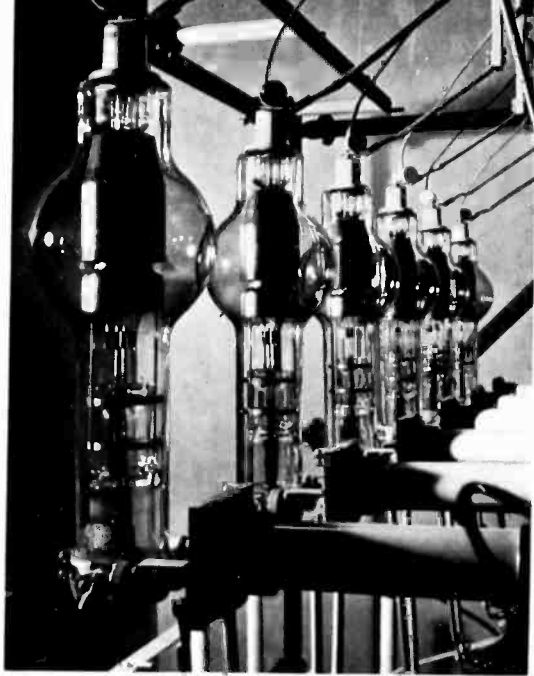

# WHN

New York, N. Y.

goes

# 50 KW



**W**HN's new 50 KW voice has been gathering in thousands of additional listeners since the powerful transmitter took to the air a few months ago. "That signal is a real audience go-getter," says a station official. "We're receiving enthusiastic reports from Canada, Minnesota, Maine, and all down the New England coast. Our programs are even being listed in some New England newspapers along with local stations." But the prize bouquet comes from a listener in Manchester, England, who pricked up his ears when he heard, "This is the nation's most powerful independent station, WHN, New York, . . . put your money in war savings and beat Hitler." The spot announcement had spanned 3000 miles on the regular broadcast band and had come in clear as a bell.

With such tributes as these, old-timer WHN starts a fresh chapter in a long and colorful history. Throughout the pages the name Western Electric appears again and again. Both pioneers in their own particular fields, they have been closely allied since the station made its initial bow in 1922. As in the case of earlier transmitters, the new system is Western Electric throughout including the old 1 KW now used as auxiliary equipment.

Long a landmark in the heart of New York's gay, glittering theatre district, WHN quite naturally locates the new transmitter building as being "six miles from 42nd Street and Broadway." Following these half dozen miles westward brings one to Rutherford, New Jersey, and in sight of the twin Blaw-Knox towers and modern building which houses the 50 KW voice. Con-

struction of the building and installation of the equipment is said to have moved along much more rapidly than most 50 KW projects in the country. In approximately seven months the job was completed — ground broken, building erected, equipment set up and the transmitter launched on the air.

With extra flood lights installed, local police on guard, doors and windows electrically locked and guns stored in the building, WHN's transmitter crew is all set to meet any threat of sabotage. Now on the air 21 hours a day, the station is ready to switch to a "round the clock" schedule should an emergency arise.

Today in the primary listening area some 14,000,000 radio fans have merely to tune their dials to 1050 kilocycles for the station's programs. Two decades ago the audience was adjusting earphones and cats' whiskers to pull WHN broadcasts out of the ether with uncertain success. The station started in Ridgewood, Queens, and was owned by a newspaper called the "Ridgewood Times." A year later it was bought by Marcus Loew's Booking Agency, the present owner.

During those post war days when night clubs were springing up like daisies and upper Broadway and its environs were known as the "Roaring Forties", two voices heard most frequently over WHN belonged to Perry Charles and Nils Thor Granlund (N. T. G.), the first announcers. Charles shouldered the added duties of publicity director, manager and all-round handy man. On nights when a performer failed to appear he would hurry down from the studios atop Loew's

State Theatre to the sidewalk, nab some passing vaudeville or movie headliner and whisk him up to the microphone.

Besides introducing his bevy of Follies beauties from the stage of the Silver Slipper, N.T.G., was, perhaps, best known for reciting Kipling's "Boots." The famous poem went out over the air so frequently that the audience must have known it by heart. Reason for the repetition was simple. It was the only piece N.T.G. could rattle off on the spur of the moment to fill in embarrassing silences. And so, when records ran out or while Charles combed the sidewalks of Broadway, "Boots" came to the rescue.

Recalling the names of some of those early stars who stood before WHN's microphone must bring a feeling of nostalgia to many a listener today. Ruby Keeler, Harry Richman, Phil Regan, Whispering Jack Smith, Van and Schenck were there, along with other big-time entertainers.

Being a local station and owned by an organization primarily interested in the motion picture industry, WHN made no particular effort to compete with stations having a national hook-up in the earlier years of operation. In 1932 it took a new lease on life and began expanding facilities. Since then the power has risen steadily from 500 to 1000 — 5000, and now to the 50,000 watt signal.

Although long familiar with the technique and performance of Western Electric equipment, WHN made an exhaustive investigation and study of various other 50 KW systems on the

*(Continued on page 36)*



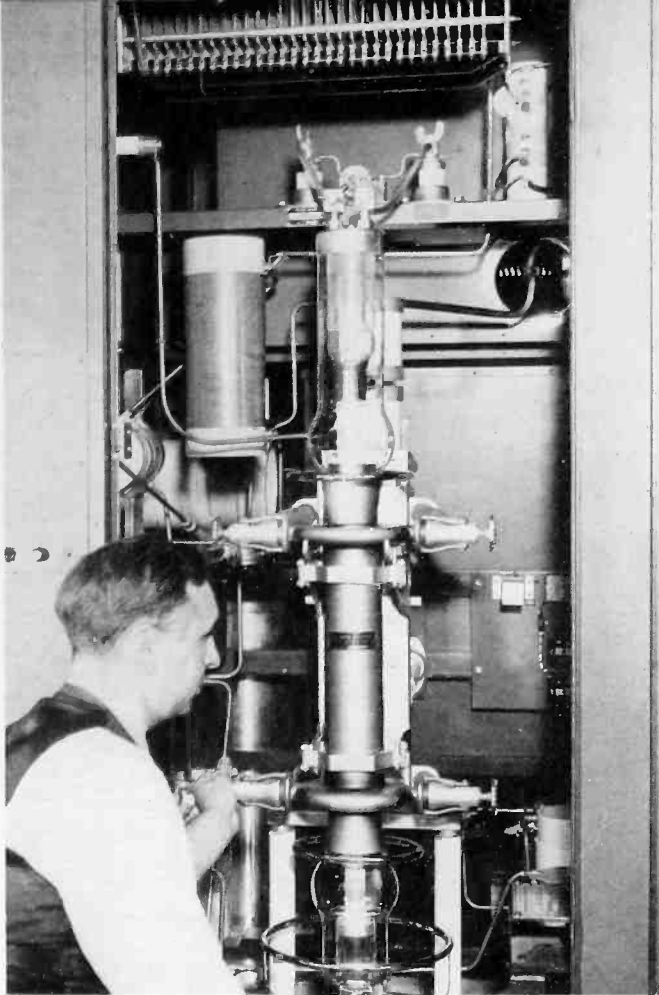

Engineer Grover W. Wizeman looks over the 298A 100 KW tube kept cool by a constant flow of distilled water

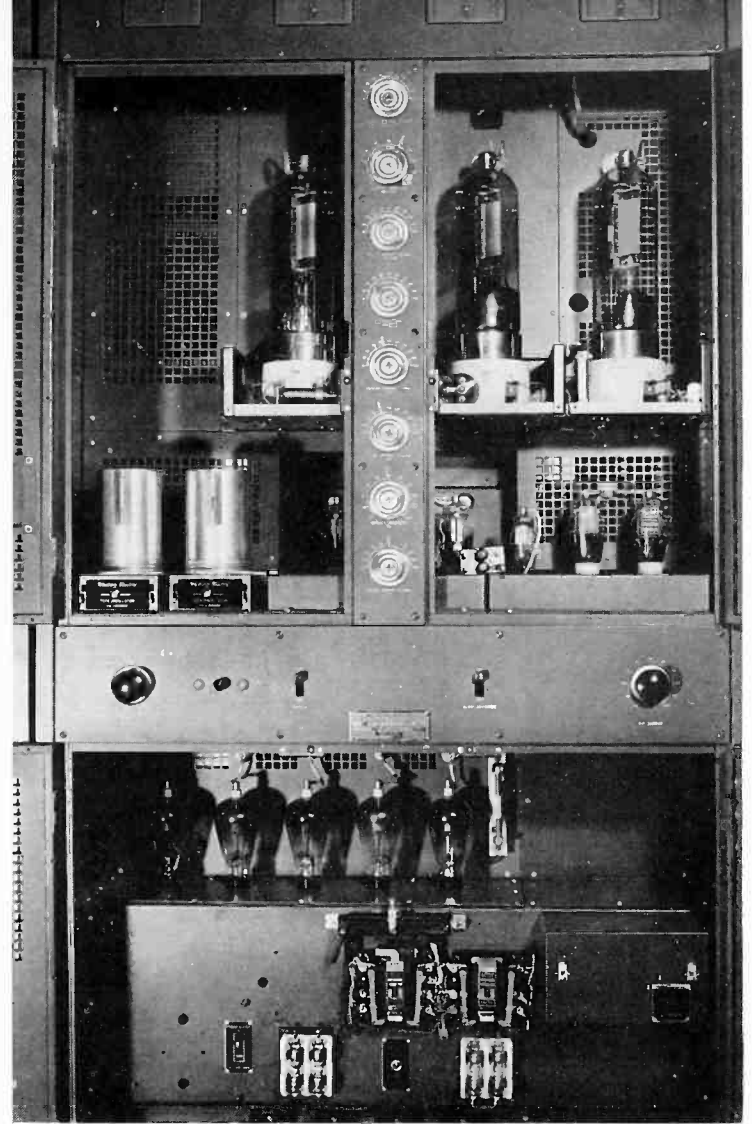

The oscillator amplifier unit containing two crystal oscillators. These maintain the assigned frequency of 1050 kilocycles

Line-up of WHN's transmitter panels showing (left to right) the 5 KW driver, 50 KW final amplifier and 1 KW auxiliary transmitter

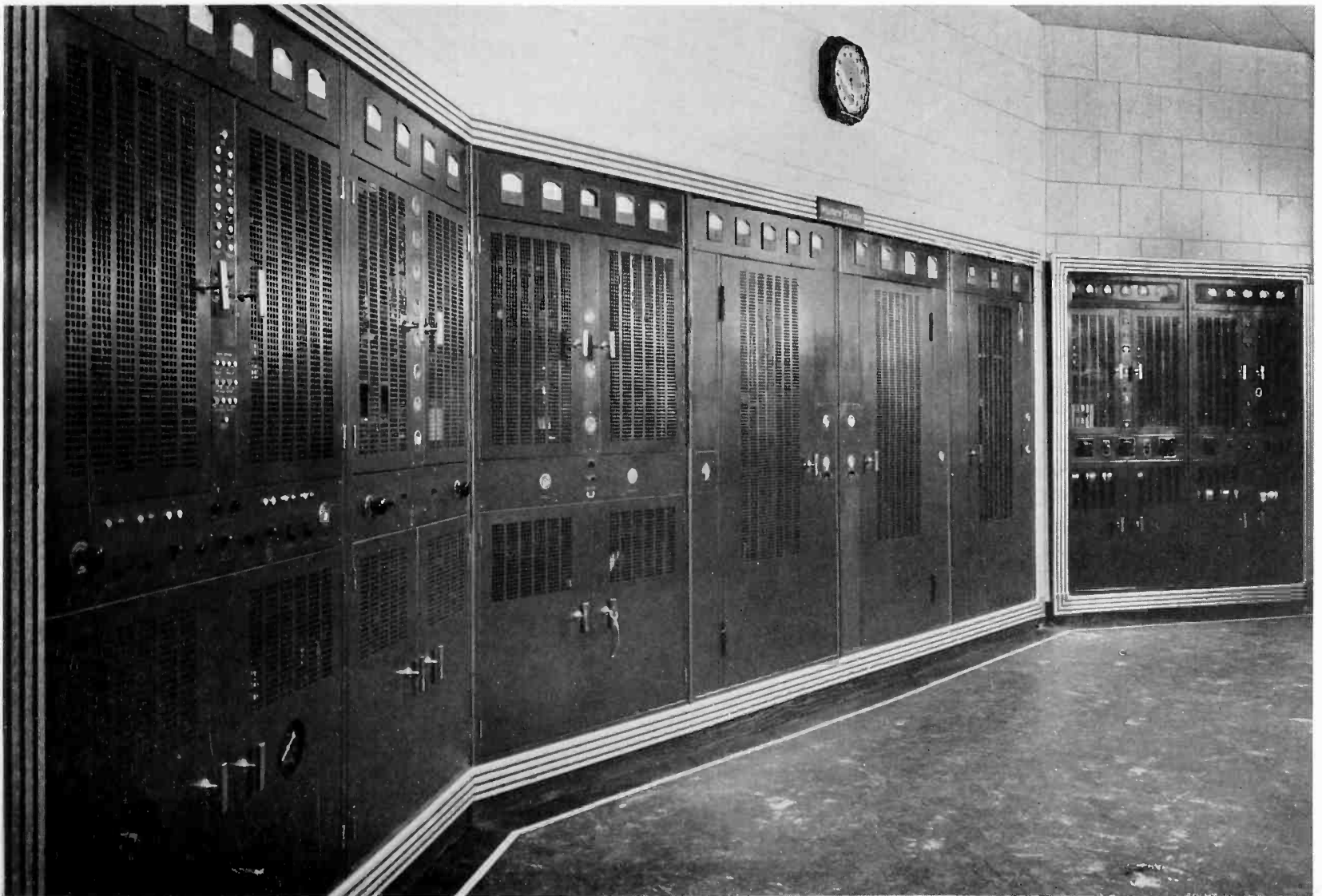

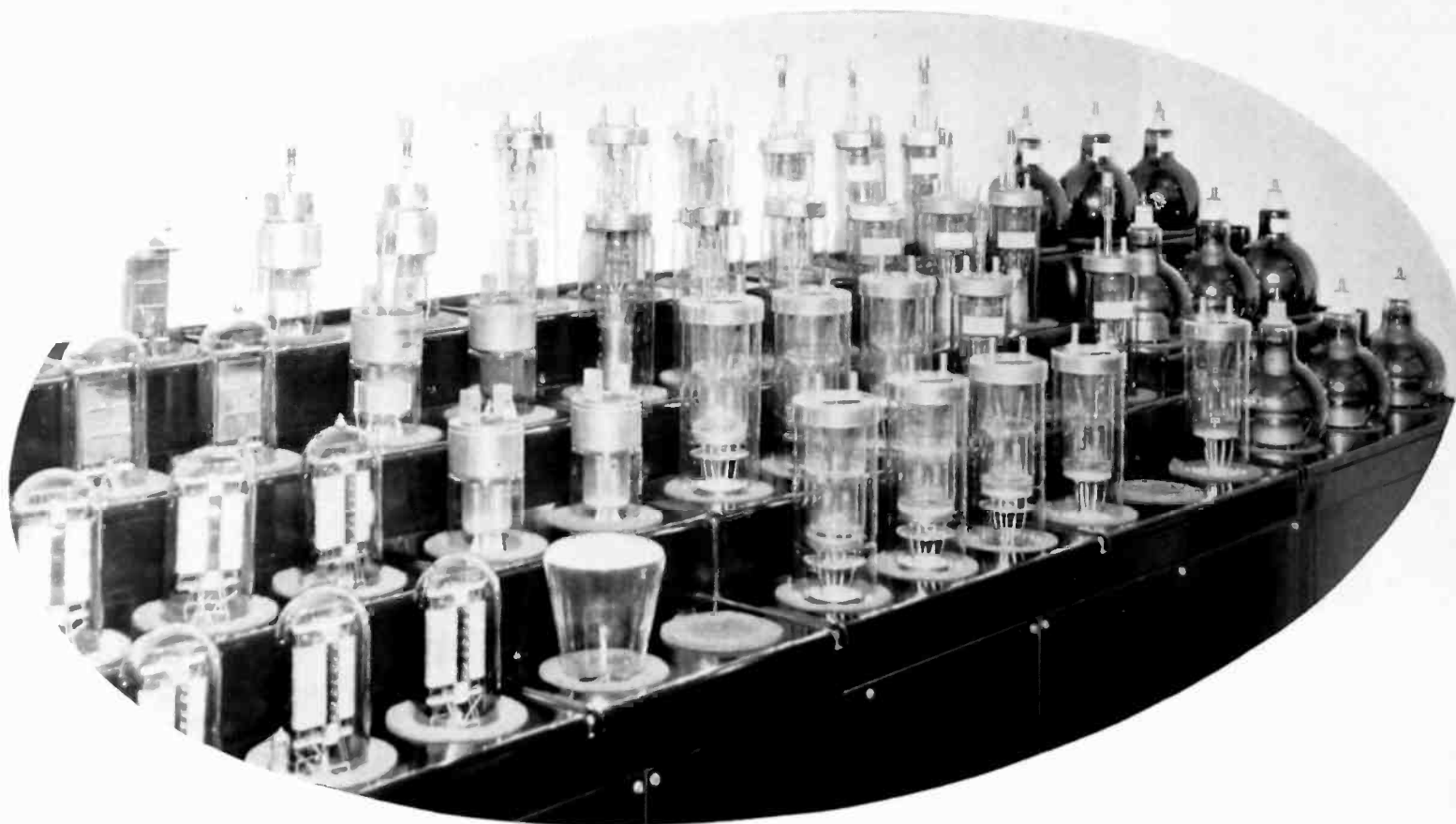

## What's Happened to Rectifier Tube Costs?

Research Cuts Tube-Hour Figures 90 Per Cent in Last Decade. Power Consumption Reduced; Efficiency Increased.

**N**EW DEVELOPMENTS in vacuum tubes—improved designs, ingenious applications, better manufacturing methods — are continually coming from Bell Telephone Laboratories and the Western Electric Tube Shop in New York City.

To make tubes which burn longer, are more efficient and cost less is the primary aim of the engineers and craftsmen who turn out these shiny glass bottles so vital to electrical communication. Some are so tiny that four fit nicely into an empty cigarette package — the two element cold cathode tube used as a telephone signal lamp is just that small — while others are massive shapes of glass and copper eight feet high and weighing 90 pounds. Tireless research into their characteristics and idiosyncracies by the Laboratories has resulted in many of the discoveries which make today's tubes so versatile and efficient.

Of the many dramatic stories connected with Western Electric tubes and transmitters, none should be more interesting to the dollars-and-cents minded broadcaster than the actual case

history showing how Bell Laboratories and Western Electric have added years to tube life and reduced their cost to a small fraction of that prevailing a few years ago. Rectifier tubes are a good example. In 1932 a 5 KW transmitter required three high vacuum rectifiers costing \$660. Mortality rates were high and the average life was then only two-thirds of a broadcasting year. Total annual bill for rectifiers—around \$1000. Today, a transmitter of the same power uses six of the improved 315A mercury vapor rectifiers which cost \$210 and last from three to four years. In less than a decade rectifier tube cost for a 5 KW station has been reduced from \$1000 to approximately \$60 a year, or better than 90 per cent. The same story holds true for 50 KW transmitters, where annual cost has been cut from \$3500 to about \$500.

Low power consumption is another economy feature of mercury vapor rectifiers. The change from vacuum to gas-filled tubes permitted a larger and more concentrated filament surface. By surrounding this with a bright metal heat shield open on the side fac-

ing the anode, less heat is lost by radiation and emission efficiency of the cathode increased several fold. When six 237A vacuum rectifiers are used in a 50 KW transmitter, cathode heating power required is 7300 watts, and roughly 20,000 watts is dissipated at the anodes. In contrast, six 266B mercury vapor rectifiers require 1260 watts for the cathode, dissipate only 350 watts at the anode, for an increase in power supply efficiency of from 83 to 98 per cent.

Experience of engineers and operators shows that rotation of mercury vapor tubes, so that spares and those in active service are periodically heated, is desirable in the interests of long life. Without this precaution there is danger of mercury getting under the active material on the filament during long periods of inactivity and injuring the emission capability.

Developments in the past few years have increased the length of service of high power water-cooled and air-blast-cooled tubes to more than twice their former life. In the case of water-cooled tubes using pure tungsten fila-

*(Continued on page 36)*



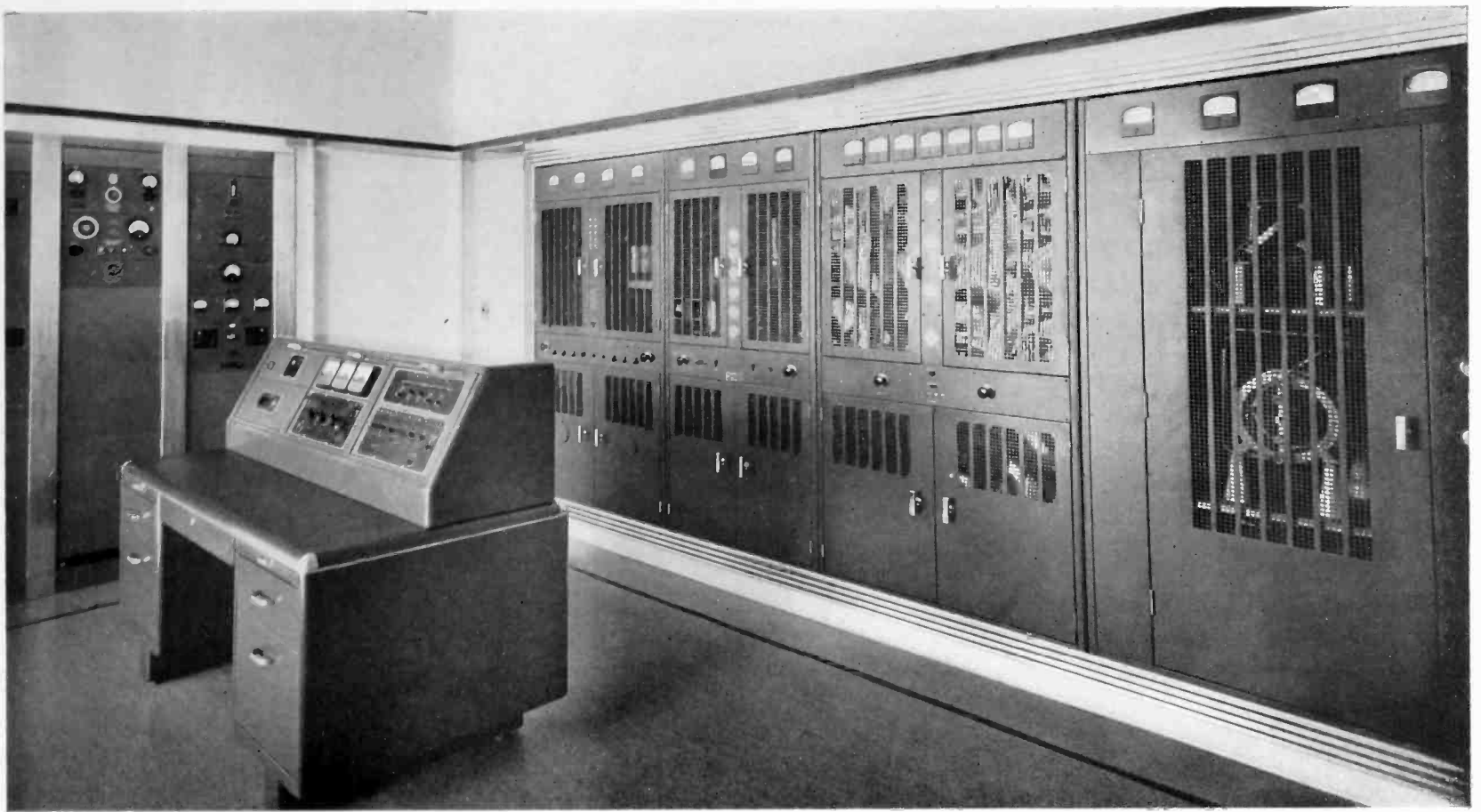

WIOD's Western Electric 5 KW transmitter. Associate equipment includes the 1126A Amplifier — new star performer in the broadcasting field.

## On an Island Built to Order WIOD Installs a 5 KW Transmitter

**B**UILDING a transmitter for an island is nothing particularly unusual. But when an island is built for a transmitter that's a "man-bites-dog" story, likely to flash into print in any newspaper. Such a story broke not so long ago down in Miami, Florida, when WIOD engineers planned and supervised the building of a little jewel of an isle in Biscayne Bay.

The spot of bay bottom purchased by the Isle of Dreams Broadcasting Company lies in the northern portion of the bay adjacent to the 79th Street Causeway. Since sea water is known to be the best conductor of radio waves, WIOD's new Western Electric 5 KW transmitter and directional antenna rest upon as fine a foundation as can be found in the country.

Talk to any of the engineers who fashioned the man-made island and they will tell you that to sink steel into solid bedrock beneath water is no mean engineering feat. After constructing a retaining sea wall, over 10,000 cubic yards of fill were dumped to form what is now known as Cameo Island. On the island an ultra-modern transmitter building was erected, embodying all the

beauty peculiar to Florida architecture, yet strong enough to withstand the gale force of tropical storms likely to whirl around the Caribbean area.

Looking more like a tropical home than a broadcasting station in its setting of palms and shrubs, the new WIOD transmitter building belies its newness and the fact that it has been recently completed on land which did not exist so long ago. The screw pines, oleanders and yuccas surrounding the structure seem to have sprung up as miraculously as the island itself.

The 320-foot Blaw-Knox towers of the directive antenna array were placed off-shore on foundations resting on the bedrock of the bay. Here is the perfect take-off for radiated signals — five times the former power, say the engineering experts.

The designing of this "seagoing" broadcasting station presented a number of difficult engineering problems, but the competent engineering staff, headed by M. C. Scott, Jr., did a job that will be recognized as one of the country's best.

The installation of the ground system, for instance, touched on an un-

usual angle in that the radials were "plowed in" with a boat. Altogether 240 radials — 120 from each tower — were attached to sash weights and dropped overboard.

Another unique feature arising from the station's island position is that the operators taking meter readings at the towers must wear life preservers. They don't claim to have become deep sea divers as yet, but they certainly have gone a bit nautical since the station set up housekeeping at this unusual location.

Practically 100 per cent Western Electric, the new transmitting system includes a 5 KW 405B-1 transmitter, 33 type control unit, 2A phase monitor and the 1126A program amplifier. This last named unit, although on the market but a comparatively short time, has already won a name for itself in the broadcasting field.

Organized in 1926, WIOD has been a recognized leader in the state of Florida since its inception. It was the first station in the State to raise power to 1000 watts and the first to bring listeners of this area a network program.

WIOD





# MIAMI



To build a foundation for WIOD's transmitter towers steel had to be sunk into solid bedrock beneath the waters of Biscayne Bay.

Upper right: Fishing? No indeed, they are plowing in radials — Engineer Fred Clark is about to toss one overboard attached to a sash weight. In this nautical manner 240 radials were laid.

Right: Scene behind the scenes in WIOD's new transmitter room showing set-up of Western Electric power supply equipment.

Left: The man-made isle in Biscayne Bay — it took 10,265 cubic yards of fill for the foundation. Miami skyline forms a backdrop.

Where the "Isle of Dreams Broadcasting Company" broadcasts from an Isle of Dreams — what a setting for the new 5 KW transmitter!

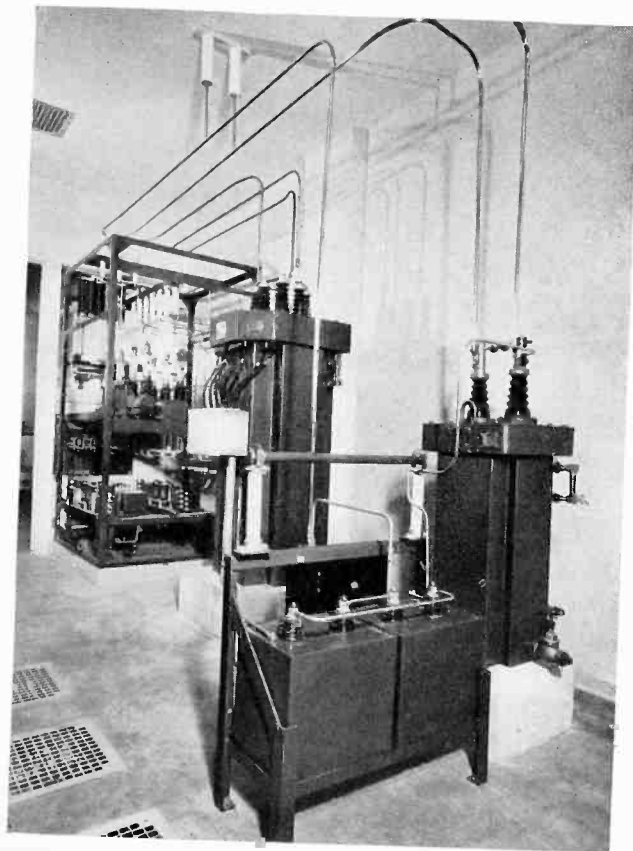





Joseph Waldschmitt, engineer, looks over the controls on the Western Electric 10 KW FM transmitter. A radically new type amplifier circuit makes the transmitter first of its kind to use a single tube in last amplifier stage



**T**HE DEDICATION of W71NY's new Western Electric FM transmitter, marks another triumphant step forward in broadcasting history. To WOR, owner of the new station, goes the honor of launching the first full-time commercial FM station in New York City. Six stations, forming the largest FM network to date carrying a single program, broadcast the opening ceremonies.

It is estimated that W71NY will be heard by owners of FM receivers in a radius of 52 miles from midtown Manhattan. The station has an assigned service area of 8,500 square miles on a frequency of 47.1 megacycles. On the air from 8 A.M. to 11:30 P.M. programs are especially designed to bring out the advantages and quality of FM broadcasting.

W71NY's debut climaxed more than two years of planning, experimenting and testing with FM transmission by WOR engineers in cooperation with Bell Telephone Laboratories experts who designed the equipment. Although the going proved extremely difficult FM development at this station is considered a record of speedy action. Plans took form back in the summer of 1939 when the first Western Electric 1000 watt FM unit known as W2XW1 was set up at Carteret, New Jersey. First test signals went on the air in February, 1940. Four months later with the call

## W71NY New York, N. Y.

letters changed to W2XOR the station moved to 444 Madison Avenue where a new Western Electric 1000 watt FM transmitter was installed. It was in the spring of 1941 that W71NY actually came into being.

WOR engineers who take particular pride in the new 10 KW FM voice, say that distortion at the transmitter is less than 1 per cent and that among broadcasting experts this is regarded as a spectacular technical achievement. There is no trace of noise at the carrier and the frequency stability is better than 1000 cycles.

The transmitter unit and the entire technical set-up are on the 42nd floor of the Madison Avenue building. A radically new type of amplifier circuit makes the transmitter the first of its kind to use a single tube in the last amplifier stage. "One tube—but what a tube!" is the way transmitter engineers speak of this baby giant. It weighs 55 pounds — one of the heaviest in radio usage today.

The most difficult problem to be

overcome in setting up the equipment was planning ways and means for hauling it to the 42nd floor. Since the elevator only goes to the 40th floor a combination of block-and-tackle and trap door contrivances were rigged up to help do the job. Despite this handicap several tons of equipment reached W71NY's rooftop quarters without a scratch.

In case of emergency the staff is prepared to continue operations for an extensive period right around the clock. Sleeping and housekeeping facilities including refrigerator, range and well stocked larder are all there in this unique penthouse. The entire layout is as spic and span and up-to-the-minute as a model apartment displayed on the pages of Good Housekeeping.

Other FM stations now operating Western Electric equipment are Don Lee's K45LA, in Los Angeles and the Moody Bible Institute W75C, Chicago. WHN will join the roster soon when W63NY is launched and W49PH, owned by the Pennsylvania Broadcasting Company is scheduled to follow along shortly.

Theodore C. Streibert, general manager and vice-president of WOR, contends that when FM gets into its stride, competition between the different local transmitters will bring about a program superiority race which will

(Continued on page 32)

This afternoon warm with moderate winds; tonight somewhat warmer than last night.  
Temperatures—Minimum, 45; Maximum, 74.  
(Detailed weather report on page 30.)

VOL. CIX—NO. 191—DAILY.

Published at Grand Central Station, New York, N. Y.

NEW YORK, WEDNESDAY, APRIL 16, 1942.

THREE CENTS

# U. S. PLANES BLAST 4 PHILIPPINE BASES HELD BY JAPANESE

## VALENTINE SHAKES UP PLAIN CLOTHES MEN

Stung to Act by Amen Exposure He Puts 113  
Back in Uniform—Rest Will Be  
Shifted in a Few Days.

## BASEBALL

AT PHILADELPHIA	B. R. C.
BROOKLYN	8 0 2 0 0 1 1 0 4 8 1
GIANTS	0 0 0 0 6 8 0 0 1 6 8 1
Riggs, Casey (7) and Sullivan, McGee, Adams (1), Melton (2) and Dandridge	
AT WASHINGTON	B. R. C.
YANKEES	0 0 0 3 4 0 0 2 0 9 13 0
WASHINGTON	1 0 0 0 2 0 0 0 0 3 11 0
Chandler and Dickey, Newsum, Euber (1), Masterson (1) and Early	

## U. S. HOLDS UP NORTH AFRICA SUPPLY SHIPS

2 Were Ready to Sail From  
New York for France

Led U. S. Bombers



## 4 ENEMY TRANSPORTS SUNK BY 13 BOMBERS

Other Ships, Docks and Aircraft Are  
in Raid—  
Struck.

123 WAR 126 WD WASHN D C 201 P APR 18 1942

THE EMPLOYEES OF WESTERN ELECTRIC CO--

TWO THOUSAND MILES ACROSS THE HOSTILE OPEN WATERS OF THE SOUTHWEST PACIFIC TO BOMB JAPANESE FORCES AGAIN AND AGAIN. THAT IS THE RECORD JUST ESTABLISHED BY A FLIGHT OF HEAVY AMERICAN BOMBERS. FAR FROM THEIR HOME BASES AND REFUELING AT SECRET FIELD, THESE PLANES STRUCK FOR TWO DAYS AT JAPANESE AIRDROMES, CONVOYS, SUPPLY DEPOTS, AND GROUND TROOPS. THEN THEY RESCUED TWENTY FIVE AMERICAN PILOTS FROM CORREGIDOR. THE PLANES THAT DID THIS JOB WERE FITTED WITH RADIO EQUIPMENT MADE BY YOU. WITHOUT YOUR SETS OUR MEN COULD NOT HAVE FOUND THEIR WAY TO THE ENEMY OVER VAST STRETCHES OF OPEN WATER. YOU PLAYED YOUR PART IN THIS ACHIEVEMENT. CONGRATULATIONS, AND KEEP IT UP.

OLMSTEAD -- MAJOR GENERAL -- SIGNAL CORPS

Stung in Brook 113 plain that w men in paveme The shake up departme gation at or Edw 271 plain patrol At the doner Val for a school where the that post in their d will be pl

Hous Wa Sub-com Plans

Washing committee vision today mande in sabotage w Concluding vestigation, U sued a long re of Governmen mg ship and had been give February 14, burned and ca Amering lib tionably start from a blow to life preserver, said his invest to disclose any intent on acts added that 16

In The S

Advertising Ne American...  
Sports...  
The Sun...  
Page 10...  
Page 11...  
Page 12...  
Page 13...  
Page 14...  
Page 15...  
Page 16...  
Page 17...  
Page 18...  
Page 19...  
Page 20...  
Page 21...  
Page 22...  
Page 23...  
Page 24...  
Page 25...  
Page 26...  
Page 27...  
Page 28...  
Page 29...  
Page 30...  
Page 31...  
Page 32...  
Page 33...  
Page 34...  
Page 35...  
Page 36...  
Page 37...  
Page 38...  
Page 39...  
Page 40...  
Page 41...  
Page 42...  
Page 43...  
Page 44...  
Page 45...  
Page 46...  
Page 47...  
Page 48...  
Page 49...  
Page 50...  
Page 51...  
Page 52...  
Page 53...  
Page 54...  
Page 55...  
Page 56...  
Page 57...  
Page 58...  
Page 59...  
Page 60...  
Page 61...  
Page 62...  
Page 63...  
Page 64...  
Page 65...  
Page 66...  
Page 67...  
Page 68...  
Page 69...  
Page 70...  
Page 71...  
Page 72...  
Page 73...  
Page 74...  
Page 75...  
Page 76...  
Page 77...  
Page 78...  
Page 79...  
Page 80...  
Page 81...  
Page 82...  
Page 83...  
Page 84...  
Page 85...  
Page 86...  
Page 87...  
Page 88...  
Page 89...  
Page 90...  
Page 91...  
Page 92...  
Page 93...  
Page 94...  
Page 95...  
Page 96...  
Page 97...  
Page 98...  
Page 99...  
Page 100...

On the white top there is a red panel which, when lighted up, spells out in red lights the legend "Mayor."

Mayor asserted with some emphasis Asks for Understanding. Speaking at a luncheon at the Yale Club in honor of Major-Gen. Robert M. Danford, retired, new head of the Mayor's own, the New York City Patrol Corps, Mr. LaGuardia pointed to the fact that his administration had been

Death came at 4:45 A. M., only twelve hours after the General had written a last column against his doctor's orders that he have complete rest. The booming-voiced Gen. Johnson was promoted from captain to brigadier-general in the first world war but he died without a commission. He broke with the New Deal and was one of the earliest supporters of Wendell L.

Continued on Page 35.

Continued on Page 35.

Continued on Page 35.

Continued on Page 35.

Continued on Page 35.

ers in Australia, American bombers...  
ing attacks on...  
ia, Cebu, Davao...  
nds on Monday...  
t...  
at its crew was...  
shipping, docks...  
ged. The flight...  
25' under the...  
Nichols Field...  
ere attacked...  
e transports at...  
ports and prob-...  
Japanese planes...  
nd; destroyed...  
Field near Ma...  
s, the announce-...  
assumably carry...

ustralia to Ma...  
400, to Cebu...  
iles south of...  
nd-trip range...  
tion was that...  
aps in Amer...  
s B-17s—the...  
trip readily

the following...  
ere destroyed...  
he Philippines...  
rt...  
e Raid...  
p attacked Da...  
at the planes...  
on the ships in...  
ing a number...  
which appeared...  
ts, but all of...  
ns ablaze...  
Down...  
nese seaplane...  
warship planes...  
beneath the...  
ng off," said...  
lled the bom...  
e phone...  
e that baby?"

to give you a...  
I put our big...  
ship into a dive...  
We were doing...  
some 300 miles an hour when we came level with the Jap to let the bomber shoot...  
"Our midship guns opened up and I saw pieces of fuselage tearing out of that Rising Sun Jap plane, which was less than 100 feet away." Also what looked like smoke, until I realized it was the rear gunner in the two-place Jap plane popping at us. I upped the throttles and told our rear gunner to cut loose. He did, cutting one wing off the enemy ship, which dived out of control."



**MORALE, ENTERTAINMENT** — Radio strengthens military, civilian morale with top notch variety programs. Stars such as Charlie McCarthy, Bob Hope (above) and the boys themselves in camp-shows link fighting forces with American homes.

**HISTORICAL EVENTS** — Millions hear history being made as Radio beams the voices of today's great leaders to far corners of the globe.



The President of the United States asks Congress for a declaration of war against Japan, Dec. 8, 1941. (Photos in this strip from Acme)

Through frequent scheduled broadcasts by President Roosevelt the whole world is kept informed of the progress of the war.

England's greatest figure comes to America and Radio sends his voice from the Capitol to every corner of the globe, Dec. 26, 1941.

**NEWS** — Radio's biggest job is feeding listeners war news and beating the Axis on short wave battle lines.



Today, the heart of a network is its news room. Pressure is intense here at NBC as latest bulletins pour in.

Elmer Davis, CBS, is typical of Radio's many news and military analysts who prepare and present latest war developments.

Broadcasting the truth to Axis dominated countries is powerful new weapon. In NBC's International Division programs are translated into eight languages.



# RADIO GOES TO WAR

The men of Radio gather for their first war-time convention of the National Association of Broadcasters, Cleveland, May 11-14, they look back at the tremendous job they have done since December 7, 1941, and ahead to the still bigger job confronting them. Here now Radio serves the people as the United Nations on the offensive in the global war for freedom.

the world



America eagerly awaited Donald Nelson's first Radio talk as he opened Victory Production Drive



General Douglas MacArthur's thrilling dash from Bataan to Australia was climaxed by Mutual's broadcast of the General's own words



Much of America's knowledge of enemy activities comes from such listening posts as this CBS short wave station



Typical of men who risk life to broadcast from fighting fronts is Cecil Brown (CBS) shown after escape from torpedoed Repulse

PROMOTION OF WAR — Radio gives time in spurring the nation to greater war effort with inspirational, informative, instructional programs



Dramatization of "Bill of Rights" (above), "This is War", "They Live Forever", "Army Hour", "Listen America" are stirring examples of America's War Cry over the air



Cooperating with OCD, Television, as well as regular broadcasts, stresses the importance of First Aid training, air raid precautions and fire fighting

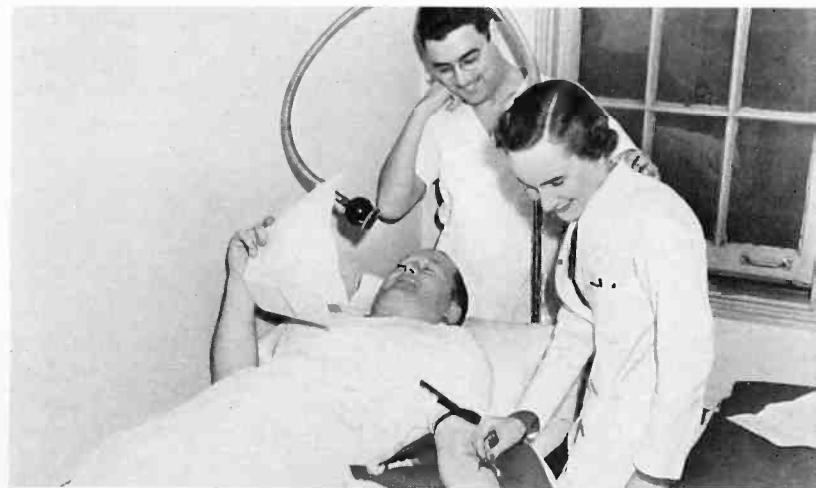

Inspiring listeners to join blood donors Dave Driscoll (WOR) broadcasts his reactions as he gives his pint

Such blackouts as this in lower Manhattan are in a large measure made possible by Radio's cooperation

(Photo from Acme)



# Radio and Sound Equipment

## 25A Speech Input Console

Western Electric has designed a two-channel speech input console which introduces several basically new ideas in speech input operation. Known as the 25A, the unit consists of the desk type console plus a small, auxiliary wall-mounted power supply unit. In spite of its compact size, the main unit houses two complete high quality main amplifier channels, capable of simultaneous operation on different programs without interference or crosstalk. It also contains preamplifier, mixer, switching, indicating, monitoring, cue feeding and other control apparatus. All of this equipment is arranged and coordinated to provide maximum flexibility and ease of operation.

When properly installed, the amplifier units and other circuit components will provide uniform, noise-free and distortionless transmission over the 50 to 15,000 cycle range. The 25A will

be found useful both in large and small installations. When a number of these units are used together to make up a system, a certain amount of master control coordinating equipment will be necessary for dispatching programs originating in the equipments and for serving them with cue program, communication facilities and the like.

An important feature of the new 25A is the small amount of installation effort required to place it in service. Use of the same type of equipment in all studio booths at a given location will aid uniform operation and make it unnecessary to change operating method with change in studio.

The wall-mounted power equipment contains the power supply units for plate and filament power to all vacuum tubes. Louvers are provided for ventilation and the equipment is mounted on a swinging frame which allows easy access for inspection and maintenance.

Built along the modern, streamline pattern that marks present day broadcasting products this 25A speech input console measures 49" long, 26½" deep, 35½" overall height above floor. Right: By swinging amplifier rack down below the front edge of table access to smaller amplifier parts and wiring is easily obtained

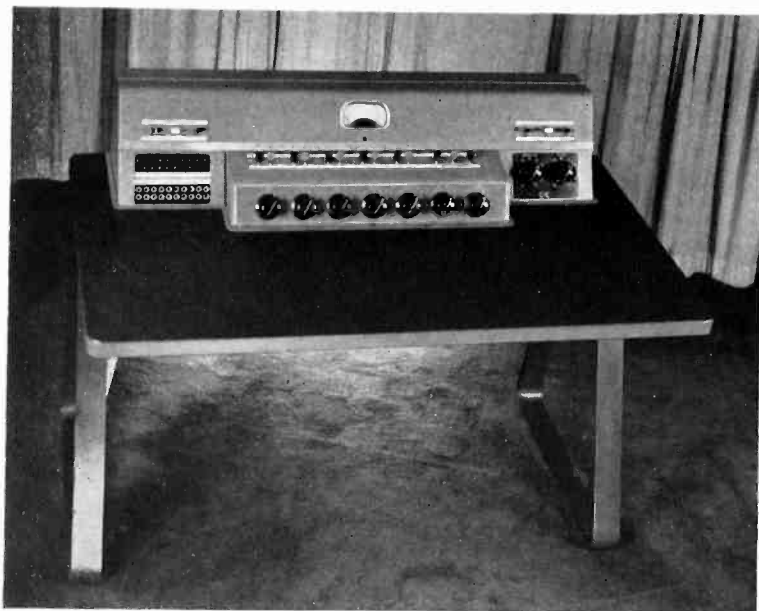

## SPECIAL FEATURES

1. Eight microphone or low level input circuits, four of which can be used simultaneously.
2. Four microphone preamplifiers.
3. Switching keys, for selecting either of two low level inputs for each preamplifier.
4. A remote line input circuit, with repeating coils.
5. Three remote line switching keys, for selecting any one of three lines, for monitor, or for program feed.
6. Patching jacks, for substituting four additional remote lines, on a line-for-line basis. Thus a total of seven input lines or trunks are available to the operator.
7. Five mixer potentiometers, for individual level adjustment on four microphone input circuits, and the line input circuit.
8. A five channel mixer circuit, with individual mixer transfer keys, for switching each of the five mixer potentiometers between the two main amplifier channels.
9. Two main amplifier channels capable of first grade simultaneous operation on separate programs.
10. Two master gain controls, one for adjusting the over-all level of each main channel.
11. Two output switching keys, allowing either of the two main channels to be fed to either of two outgoing lines.
12. Line isolation pad for each line, which serves to stabilize line impedance, and aids in maintaining high grade transmission.
13. A volume indicator, for visual monitoring of program level to the lines, with switching key for connecting to the output of either of the two main channels.
14. Jacks for individual head phone monitoring on each of the two main amplifier channels.
15. A monitor amplifier for aural monitoring, with the booth loudspeaker, of programs on the two main amplifier channels, on the incoming line circuits, or on an external cue feed circuit from master control; also for feeding cue program to the studio speaker and to the remote line circuits.
16. Monitor transfer key, giving the monitor amplifier input access to programs on either of the two main amplifier channels,

and to the cue transfer key.

**17.** Cue transfer key, for switching between the conditions of monitoring on the remote lines, receiving cue from master control, and feeding cue to the remote lines.

**18.** Gain control for monitor amplifier.

**19.** Loudspeaker cut-off relays, for the booth and two studio loudspeakers, with strapping board for interlock with microphone input keys to automatically prevent operation of loudspeaker in same room with a live microphone.

**20.** Contacts for closing control circuits to relays outside this equipment for operation of studio warning signs, buzzer cut-offs, and other auxiliaries.

**21.** A branching circuit, with gain control and channel switching key, for feeding a separate local amplifier system external to this equipment. This is useful for sound reinforcement in large audience studios and for similar applications.

**22.** A plate metering circuit with meter and rotary tap switch, for quickly checking individual plate currents of all amplifier tubes to determine that they are normal.

**23.** Power supply for operating loudspeaker cut-off relays.

**24.** Space for addition of 20 jacks, lamps or jack-sized keys as required for system control, and indicating circuits.

**25.** Adequate terminal facilities to accommodate incoming and outgoing line and program circuits and power supply feeds.

**26.** Talk-back control key for switching one microphone input circuit and the loudspeaker control circuits for talk-back from the control room into the associated studio.

## Sound System Units

Recent developments in the field of sound distribution have brought from Western Electric's Specialty Products Division several new products including three loud speaking telephone units, a loud speaking receiver, a crystal microphone and a loud speaking horn — designed to further improve the quality of voice and music reproduction and increase the range of amplification.

The loud speaking telephone units known as the 753A, 753B and 753C may be used for radio broadcasting as well as for public address and music reproduction systems. Due to its high frequency range (60 to 15,000 cycles) the A unit is suitable for reproducing both AM and FM broadcasts. The C unit covers a frequency range of 60 to 10,000 cycles while the B unit operates on a 60 to 6500 cycle range. With full speech power of a 25 watt amplifier, this loud speaking telephone equipment will reproduce an intensity level of 73 db above  $10^{-16}$  watt per square centimeter at a distance of 100 feet on the axis of the loud speaker. The coverage angle is substantially uniform with respect to both frequency and intensity over an angle of 90 de-

grees horizontally and 60 degrees vertically. The units are capable of handling speech or music with peak powers of 25 watts — impedance is 16 ohms.

The loud speaking receiver, coded 713A is for use in high quality sound systems employing two loud speakers. One of these is a low frequency unit. The other consists of the 713A coupled to a suitable horn such as the Western Electric 31A or 32A. With the former horn, the 713A receiver responds in the frequency range of 300 to 10,000 cycles; with the other horn its range of response is 500 to 10,000 cycles. When frequencies around and below the low-frequency cut-off of the horn with which it is used are sufficiently attenuated, the receiver is capable of handling the full undistorted output of a 25 watt amplifier producing speech or music. Voice coil impedance of the receiver at 1000 cycles is 16 ohms.

The new microphone (D-173069) is of the crystal type, designed particularly for announcing use with public address and group audiphone systems using the Western Electric D-151195 Amplifier. Response of the microphone is such that it will cover the range of 150 to 6000 cycles with the fidelity required in the public address field. Frequencies below 150 cycles have been purposely suppressed in order to discriminate against undesired noises which commonly occur at the lower frequencies. The instrument contains a bimorph rochelle salt crystal in which two crystal elements poled oppositely are cemented together rigidly and operate in flexure. In order to increase the efficiency of the microphone the crystals are connected in series.

The loud speaking horn (32A) is an exponential type for sound systems where wide angles of horizontal coverage are necessary. While designed primarily for use as a part of a high quality speaker system such as the Western Electric 753 type, the 32A Horn may also be used to advantage as an independent speaker — especially for announcing purposes or in installations where a high background noise level must be over-ridden. When used in conjunction with the Western Electric 722A or 713A receiver or an approved equivalent, the horn is capable of providing a substantially uniform coverage angle with respect to both frequency and intensity over a horizontal angle

(Continued on page 38)

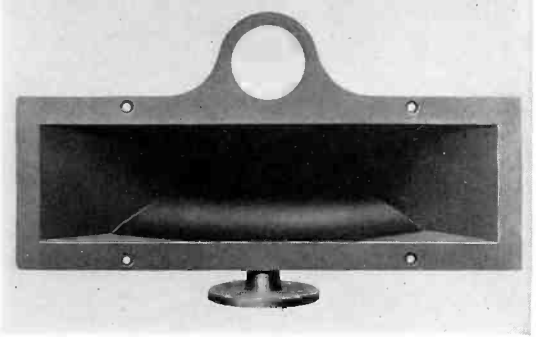

Loud speaking horn for sound systems where wide angles of horizontal coverage are needed



Crystal microphone for announcing use with public address and group audiphone systems



Loud speaking receiver for use in high quality sound systems which employ 2 loud speakers

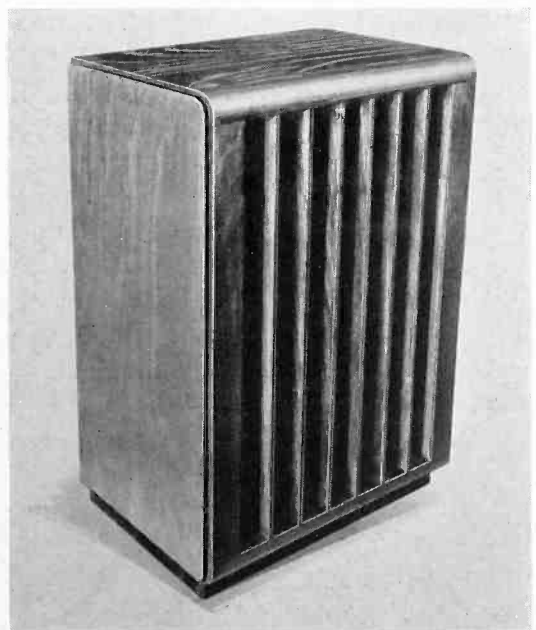

Loud speaking telephone unit for radio broadcasting, public address, music reproduction



"Let's put more punch in this script," says Professor Waldo Abbott, Director of Broadcasting, University of Michigan, as he checks work of students at writing conference. The University lists 50 graduates employed in commercial stations, 55 in work allied with radio



## Is College Training in Broadcasting Worthwhile?

Educators Say Yes; Some Broadcasters Skeptical — Industry's Need Is for Down-to-Earth Training in Salesmanship, Advertising, Station Management.

By M. M. BEARD

**T**HOUSANDS of eager young men and women are knocking on Broadcasting's door each year seeking jobs in one of the most fascinating and fastest growing industries the world has witnessed. NBC estimates that over 12,000 applied in person at their New York Headquarters during the first nine months of 1941. Columbia lists 2100 personal applications and over 10,000 letters for the same period. Untold numbers are contacting other networks and the 880 stations scattered throughout the country.

Masters and Bachelors degrees, high school diplomas plus a wide variety of talents, attributes and aptitudes are being proffered by these young hopefuls as the golden key to turn the lock. The "new idea" man — the choir singer — the dramatic society's leading lady — the school paper editor — the boy with the announcer's voice — the town players' coach — the cub reporter — the advertising whiz — the breezy office boy — all aspire to work behind the mike in one capacity or another. And upon the shoulders of those who are chosen will rest broadcasting's future.

Since the industry ranks as one of

the most important and influential enterprises in the country, the background, training and talent of the men and women who are to participate in building that future must necessarily be of vital concern to the 100,000,000 Americans who comprise the listening audience as well as to the industry itself.

How are these embryo broadcasters being prepared for the job?

Are colleges and universities offering adequate training facilities?

What are broadcasters themselves doing to train and build efficient staffs?

What chance of making the grade have the thousands of radio job seekers?

These are some of the questions PICK-UPS set out to answer through contacts with the broadcasting industry, with higher educational centers

This survey was completed just prior to the United States entry into war. Although college training and employment practices may have been altered to meet war needs we feel that the information presented here is still of interest and value to educators and broadcasters.

and by delving into various surveys and round table discussions touching on the subject.

Numerous educational leaders seem to agree that while students long have been able to prepare for law, banking, engineering, medicine and other professional careers, little has been done to equip them, under university training, for participation in radio broadcasting. Others still hold to the opinion that radio is not a profession and that there are not enough openings in the field to warrant setting up extensive radio curriculums. Some groups of broadcasting men are encouraging educators to stress radio training — others are against it or merely indifferent.

Franklin Dunham, of NBC's Educational Division, contends that a Bachelor's degree should be a prime necessity in any branch of broadcasting. Here is a brief review of the situation as he sees it. "Up to 1938 most of the courses in radio given in colleges and universities were announcing, radio writing and drama. This is not a very good record after 15 years of radio development in an industry utilizing something like

\$200,000,000 worth of attention but with no appreciable amount of actual vocational training being carried on. Three universities have started courses leading to a B.A., no university has yet offered a complete graduate course in radio but many now offer courses that may be credited toward a Masters degree". Mr. Dunham agrees that this is a big step forward. He also admits that there has been a lot of scepticism within the industry in regard to radio courses.

Another educational leader who has done extensive research work on the subject of radio as an occupation is Kenneth G. Bartlett, director of the Radio Workshop at Syracuse University. Mr. Bartlett takes the stand that while job competition is extremely sharp and employment opportunities limited there is a chance for newcomers. The industry is anxious to recruit young people with the right abilities and training he says, but it does put a premium on ideas and talent and it is not an easy road to fame and fortune. He advises a person interested in entering the field to get acquainted with the many branches of the work, see what part requires specialized training and then ask himself what phase interests him most. Broadcasting's trend, he says, is to use college trained men and women. He believes, however, that originality, personality, intelligence, judgment, mental flexibility and ability to guess the public's taste are more important than the mere holding of a degree.

Below: Spurred on by Professor Robert S. Emerson (extreme right) these New York University students get plenty of action into a comedy skit. Right: How to get the show off the air in the allotted time is a puzzler for these broadcasters at Kansas State College

According to latest statistics 383 colleges and universities out of approximately 1800 in the country are scheduling courses in radio exclusive of engineering. Only three offer a B.A. in a combined liberal arts and radio course. Twelve list graduate courses which may be applied to an M.A. Altogether 755 radio courses are being conducted in our halls of higher learning. Of these 230 deal with dramatics and speech; 120, general; 101, script writing; 97, program planning and production; 48, education by radio; 49, announcing; 40, advertising; 34, newscasting; 23, music; 7, management; 3 radio law; and 3 in radio sociology.

Many of the colleges offering courses have established radio workshops which generally serve a threefold purpose — as broadcasting outlet for the school — as training center for radio students — as a filter through which commercial stations pass along broadcasts of nonprofit groups.

According to Leonard Power, coordinator of research projects sponsored by the Federal Radio Education Committee, these workshops can only function properly if they are equipped and operated to meet the most exacting requirements for satisfactory production of high quality programs. Directors should be so experienced in broadcasting that their productive abilities are appreciated and valued by the station managers with whom they work.

Reports from numerous colleges show that their workshops are meeting these high standards — that their radio instructors and workshop directors have had wide commercial broadcasting experience. More than a few of these men

have been drawn from the networks and large stations.

At least 24 colleges are operating their own stations as distinct from colleges which broadcast programs through the facilities of commercial stations. Most of the college owned stations operate under educational licenses but a few are listed as commercial stations using sponsored programs.

The three colleges which went into action to remedy the lack of radio B.A.'s are New York University, Drake of Des Moines and Alabama. N.Y.U. and Alabama combine radio with liberal arts and science — Drake links it with liberal arts and business training. All three courses are designed to give students a broad liberal education with an introduction to radio technique, which according to broadcasting leaders, constitutes the best preparation for employment in the field.

N.Y.U.'s curriculum includes radio writing, speaking, use of music, announcing, planning and producing programs, station operation, legal relations, advertising, audience psychology and the educational uses of broadcasting. But students are prepared primarily for the field of program planning, writing and production. Liberal arts and science comprise three-quarters of the program — radio the balance.

The University of Alabama claims that radio there rates as high as chemistry, philosophy or Latin. More than 200 out of 5,500 students take courses in it and 60 concentrate on it as a major.

In 1934 Drake decided that radio was destined to become a most important field vocationally. Although their





Can colleges teach broadcasting? Well four of these Drake students have been employed by commercial stations as announcers and continuity writers. The other two are still in college

survey in other colleges did not encourage the "School of Radio" plan, Drake thought it worthwhile to pioneer and that year established a radio department. The plan has been to concentrate on the administrative angle of broadcasting. Classroom work is coordinated with the radio workshop which is responsible for planning and producing 500 broadcasts a year that go out over commercial stations, regional and national networks. The student radio staff is organized along the lines of a commercial station with a head program director, production director, continuity department head, music director, chief announcer, special events, sports, women's department, news, traffic, etc. Freshmen start as assistants and work up through most of the important phases of commercial station activities. They must meet commercial broadcasting standards since more than 90 per cent of the broadcasts are aired over commercial stations.

With very few exceptions, says Drake, their students have found better than average positions and most have had excellent records of advancement. Graduates have found employment in radio stations in 12 states. One is program director of a 50 KW station, another a commercial manager in an important station; others are news editors, continuity writers, announcers or with advertising agencies.

In 1932 Kansas State College turned attention to training students for the business phases of broadcasting.

Early students, nearly all of whom wanted to become actors or announcers, soon realized that there is plenty of interesting work to be done before the show can go on the air. Today, Kansas State's most important courses are writing, production, advertising, programming and research.

This college discovered an interesting side light which has cropped up during the past few years. Young women, graduating with degrees in Home Economics who have had some radio are in demand in the field of commercial home economics. Meat packers, millers, bakers, canners, manufacturers of kitchen appliances, etc., want women who have had training in continuity writing and radio research. Few graduates, says the college, go directly into radio advertising but many work from continuity, traffic or programming into sales promotion. Some are doing commercial radio research.

The University of Michigan, another radio-minded institution, lists 50 graduates employed in commercial stations and 55 engaged in fields intimately connected with radio. Waldo Abbott, Michigan's director of broadcasting, points with pride to the rapid progress made by a number of these former students. One is director of the Sports Reporting Staff for Yankee Network; another is a member of the production staff of CBS; a third has become assistant station manager for WHLS; and a young woman graduate is program director for the 50,000 watt WJR.

Ohio State University tells a somewhat different story. In 1939 the university put out feelers concerning a possible radio curriculum with a bachelors degree in the offing by conducting an interesting survey covering over 100 stations. Replies to questionnaires showed that 68 per cent of station executives gave preference to college graduates when hiring new employees — 59 per cent preferred graduates who had a good general education including radio courses — 17 per cent favored students with a college degree but not radio trained. Six times as many stations advised colleges to prepare graduates for a radio career as advised against it. The vote was 29 to 12 in favor of advising college women to follow radio as a career. One illuminating factor cropped up in the report that most stations seemed to want advertising training.

Getting down to the cold facts of actual radio job opportunities for college graduates, with or without radio training, Ohio State received something of a jolt when it learned through the survey that in 95 stations reporting the average annual rate of turnover was only eight per cent or one new employee hired for every 12 members on the staff. Using 1938 figures of 16,000 broadcasting employees in the country Ohio figured approximately 1,300 openings for new talent in the field each year or less than two jobs per station.

The survey resulted in a "No" verdict from Ohio authorities for the following reasons: number of positions to be filled not large enough at present; demand for radio trained college graduates not sufficiently heavy; setting up such a curriculum might offer too much encouragement to radio career minded students.

Ohio does however encourage elective radio courses whereby the student would have a major to fall back on should his radio opportunities not materialize. In other words "have two strings to your bow" is this university's advice. At a later round table discussion, J. Morrill, Vice President of Ohio State University in charge of Radio activities, further emphasized the stand taken by saying, "This radio business is a new and confusing field. I do not believe we should dignify it by calling it a profession or rush to set up curriculums. We should regard it simply as an interesting vocation — like aviation."

Evidently, the three universities



making the plunge for radio B.A.'s feel they have safeguarded their students from being left out on a jobless limb if broadcasting passes them by. The preponderance of liberal arts and science in the scheduled programs would seem to offer a well-rounded education fitting graduates for jobs in various other fields.

Now let's look at the picture as broadcasting sees it — both through the networks' eyes and those of the stations.

According to Ashton Dunn, personnel director of NBC, the network's headquarters hired approximately 450 new employees during 1941, not including pages and messengers. The general practice is to move up its own members or fill gaps in the ranks with experienced men from other stations — particularly higher-up jobs.

Junior positions are filled by pages and messengers who are carefully groomed to step into such openings as they occur. These young men, about 80 per cent college graduates, are originally selected because they have something special to offer NBC. They may have majored in advertising, electrical engineering, journalism, business organization or salesmanship. But radio training is by no means necessary. Besides acting as receptionists, messengers and guides, the young apprentices spend certain periods attending classes. The training, carried on for a two year period, includes station management and research work. Many of the recruits who cannot be absorbed into the staff find jobs in smaller stations eager for NBC's trained men.

Embryo announcers, chosen

through auditions, spend six months to a year learning pronunciation of musical and foreign terms, ad-libbing, delivery and showmanship. Staff script writers frequently are former free lancers who have sold their wares to the network.

The Columbia Broadcasting System follows a well established training practice inaugurated six years ago. The goal, says Joseph H. Burgess, Jr., personnel director, is the training of young college graduates in all phases of radio business. In the network's offices and studios they are given the broad experience so necessary to successful radio work before allowing them to specialize in the phase for which they have shown the greatest aptitude. Like NBC, trainees not absorbed by the network generally find positions in other stations or are grabbed up by advertising agencies. And like NBC, Columbia does not show particular interest in radio trained graduates. If they have it, well and good, but they must qualify in other respects. Columbia's pages and messengers are younger than NBC's — not college graduates — but they must continue higher education in off hours. Announcers' requirements are rigid, a college education or its equivalent; experience in two or more local stations, a voice and air personality distinguished without affectation; and an accent that cannot be identified with any particular section of the country.

Both Mr. Dunn and Mr. Burgess frankly admit that the chances for the great majority of radio job seekers are not good. Outstanding young people who have a definite and demonstrated

aptitude for some phase of broadcasting — young people who can produce new ideas — good ideas — are in great demand. Not only will these fortunate few find openings but their chances of advancement are excellent.

They urge applicants to seek work with smaller stations where they will attain the broad view of radio so necessary to future success. Says Mr. Burgess, "The young man who gets a job as receptionist in a 100 watt is likely to find himself writing a little continuity, a 50 word commercial for the local butcher or baker and some publicity copy. He may also look over the shoulder of a production man worried about getting the show off the air on time. This is the way to start a radio career." Columbia's all 'round training plan is an attempt to approximate small station experience.

WOR, key station for Mutual, holds to a definite policy of promoting from within the ranks. To make such promotions possible, great care is taken in the selection and advancement of assistant department heads and general station personnel. While the station does not demand college graduates it does draw on colleges for new members but rarely for specifically trained men.

WOR's J. R. Poppele, outstanding radio pioneer, feels that too many college courses stress production, script writing, acting and announcing to the detriment of such important functions as station management, advertising and promotion, and business administration. He feels there is a definite need for practical teaching by people actively engaged, or who have been engaged,

On come the sound effects — these Syracuse workshop broadcasters are taught to pick up the cue and start the "platter" on the split second.

Lucky applicants selected by NBC from thousands who seek jobs there attend classes in research and management while serving apprenticeship



in all phases of modern radio.

Personnel and employment practices in individual stations differ from those of the networks and vary according to the size, location and financial status of the organization. Consequently station managers may look at radio training and job opportunities from a different angle. To present their stand PICK-UPS conducted its own survey covering a cross-section of the country and including stations of all sizes — from 100 watts to 50 KW.

Results would indicate that a large majority definitely favor such training since 82 per cent of those replying give preference to applicants who have taken radio courses and have had college broadcasting experience, provided they qualify in other respects. The few who oppose the training do so on the grounds that commercial radio cannot be taught in the classroom. Approximately 50 per cent warn against turning out an over-supply of radio trained graduates. Many in favor of the training think that while the colleges are doing a helpful job there is still plenty of room for improvement. Such comments as "Too much time spent on non-commercial phases", "More selling technique for announcers", "Training too sketchy", "Should concentrate on business angle", came through in quantity.

Here are a few criticisms and suggestions passed along by station managers which may interest the educators.

"I hope the schools do not lose sight of the practical problems in running a radio station by concentrating on the artistry of the business. We can use five persons who can write a good solid commercial that sells to every one person who can write a good dramatic or variety script. We prefer an announcer who can sell to one with the 'perfect voice'. In short, we consider radio as more of a business than an art. If the colleges could give that kind of training they would be doing a real service to the radio stations."

"Colleges would do well to include courses which adapt the student to a down-to-earth, forthright salesmanship in their announcing and the instruction of the fundamentals in radio advertising."

"I think there is a need for courses in selling as applied to radio — radio accounting practices — station promotion and public relations and management."

"In the field of sales and sales promotion, we look to the advertising field or the field of advertising-selling to obtain a thoroughly experienced man. We find that we can quite readily make a good radio man out of a good advertising man, but it's sometimes quite difficult to make a radio man into a successful advertising man. Present day radio stations must have excellent advertising knowledge and understanding if they are going to succeed in the light of competition."

"I would be very glad to see more extensive training in colleges, with perhaps the broadcasting stations themselves participating to the extent of offering special summer work opportunities to students of that type. The industry needs all of the well-trained persons it can possibly acquire."

"The broadcasting industry must of course inject fresh ideas into its life stream. We know that the best production man in the United States may never have seen the inside of a broadcasting station. If the colleges send well-equipped people to us, they will find their way into the business."

"One discouraging factor in employing college trained personnel is their eagerness to make too much money too fast. However well trained they may be academically they must still adjust themselves to the peculiarities of the individual station operation and wait for the opportunity to move up, if, as and when they have demonstrated their ability to handle a more responsible job."

"I am not sure that the general run of colleges should make any concentrated attempt to train students toward the point of specialization which is required in major radio operations today. If we could have one or two really worth while radio schools of the standing and importance of some of the post graduate institutions such as the Harvard Business School, it might be a good start toward real radio training. Give likely students two years of concentration in a real radio college — with top-notch, experienced, practical radio men, and you would be pretty well bound to turn out some personnel which the industry needs today and will need more sorely in the near future."

Stations reporting to PICK-UPS hold out a more hopeful picture to radio job seekers than did those answering Ohio State's survey which

showed the low turnover rate of 8 per cent. PICK-UPS' figures give 17 per cent. Two factors have undoubtedly influenced this 100 per cent increase. The Ohio figures were compiled in 1939 and broadcasting has expanded since that time. Job turnover rates have been taking a more than normal rise since the defense program and selective service act were inaugurated.

Although the question of radio training — its bearing on radio job opportunities and on broadcasting's future — is still a controversial one among educators and broadcasters, information set forth in this article indicates that it is heading toward a satisfactory solution. Better planned curriculums — more efficiently operated workshops under the guidance of instructors with commercial broadcasting experience are being established in more colleges and universities.

Educators are concentrating more on the practical problems of running broadcasting stations and less on the artistry of radio than they did a few years back. While broadcasters still feel too little is being done along the lines of management, advertising and selling, station managers are opening their doors a little wider to radio trained graduates.

Both groups seem to agree that job competition is sharp and employment opportunities limited but that young people with real ability and proper training stand a fair chance of finding a place in the industry. They also are in accord in advising applicants to seek positions in smaller stations where they will attain the broad view of radio so necessary for future success.

If educators will continue to improve curriculums and at the same time limit enrollments so that the supply of graduates will more nearly balance the number of jobs available —

If broadcasters will establish closer contact with the colleges — if more of them will give radio trained graduates a chance to prove their worth —

If young people, long blinded by the glamour of radio, will open their eyes to the fact that few are chosen to act or announce before the mike and turn attention to other phases of broadcasting —

Then all three groups — educators, broadcasters and job seekers — will have gone a long way toward solving their own problems and those of broadcasting's future.



## KTAR Becomes Most Powerful Station in Arizona With a New Western Electric 5KW Transmitter

**B**OOSTING its signal from 1 to 5 KW with a new Western Electric transmitter, KTAR, key station for the Arizona Broadcasting System, became the most powerful broadcast unit in the Sunset State. The expansion program under which increased power took place includes the construction of a modernistic transmitter building, directional antenna system, 35 miles of wire ground system and complete remodelling and enlarging of studios and offices atop the Heard Building in downtown Phoenix.

"First" has been KTAR's byword these many years in Arizona annals. It was the first commercial station in the state, first full-time 1000 watter, first 5000 watter, first to become a network member. Then, too, under the call letters KFAD, back in 1922, it was one of the country's pioneers, sturdy enough to endure broadcasting's growing pains during the early years.

Outstanding among the station's many notable programs heard over

nation-wide hook-ups is the famous Easter Sunrise Service broadcast annually from the Shrine of the Ages — the Grand Canyon. From year to year high dignitaries of the Episcopal ministry have journeyed to the south rim of the Canyon to take part in these inspiring ceremonies. All phases of these broadcasts are either handled directly or supervised by KTAR's program and technical

departments. Time involved has meant days of patrol duty on forest service phone lines which hang from almost inaccessible points, to prevent the slightest possibility of line failure. Always the service is built around the central theme paralleling in some way the Grand Canyon itself. Each service represents a composite of three parts—the music, a five minute description of the actual sunrise and short sermon.

A strong advocate for teaming radio and education, KTAR and its affiliated stations are closely associated with the University of Arizona, from

*(Continued on page 38)*

The 5KW transmitter and associate equipment including turntables are Western Electric







# STABILIZED FEEDBACK

## for Radio Transmitters

Beginning with this issue, *Pick-Ups* will carry digests of articles on some phase of broadcast engineering. Each subject covered will represent an important step in radio's development of continuing interest to engineers.

### Stabilized Feedback

By H. S. BLACK  
Member, Technical Staff,  
Bell Telephone Laboratories

**F**EEDBACK is the action which may take place when a portion of the output of a transmission device, such as an amplifier, is returned to its input. The feedback can be either positive or negative, that is, in a direction either to increase or to decrease the amplification. Stabilized feedback employs the negative feedback principle in a new and revolutionary manner to actually control the properties and characteristics of wave transmission systems.

If to a typical vacuum tube amplifier fed from a source of input waves to be amplified, we add a suitable path for returning some of the output wave to the input, the waves appearing on the grid of the first tube come from these two circuit branches. Thus there are three waves to be considered in relation to the input side of the amplifier: the incoming or signal wave; the feedback wave; and the voltage wave on the first grid, which is the algebraic sum of the first two.

A primary consideration, of course, is whether the feedback wave is positive or negative. Both types of feedback have been utilized heretofore. The principal use of negative feedback has been, until the advent of stabilized feedback, in the "neutralization" of radio frequency amplifiers, to overcome the inherent tendency toward self-oscillation due to positive feedback through inductive or capacitive coupling of elements of the input and output circuits. These effects become more pronounced as the frequencies become

higher and are often of such a nature as to place a definite limit on the amount of amplification that can be utilized.

Negative feedback as heretofore commonly applied in radio frequency amplifiers has had as its purpose the reduction or cancellation of inherent positive feedback. If the negative feedback is increased from an infinitesimal amount in any given case, it reaches its optimum value in opposing positive feedback when it just equals the positive feedback. At that point the amplifier is a strictly unilateral circuit having no feedback, positive or negative.

In contrast to the use of negative feedback as discussed above, the stabilized feedback amplifier employs negative feedback in much larger amounts and for a different purpose. For stabilized feedback the negative feedback is increased to a value where it not only equals but greatly exceeds the amplitude of the wave that is effective on the first grid.

Thus a small wave effective on the grid controls a cycle of operations involving waves of much greater magnitude. Far from resulting in liability to self-oscillation, a technique has been discovered whereby the greater the negative feedback ratio the more exact is the correspondence in all respects between the output wave and the incoming wave, so that it may be said that the more complete is the control of the output wave by the incoming wave.

The following example will be helpful in illustrating how stabilized feedback in an amplifier improves the fidelity characteristics.

It is generally accepted that the amplified signal wave in the output of

an amplifier is accompanied by distortion produced in the tube, and as the signal output is increased, the percentage of distortion will increase.

In a simple system to which feedback can be applied but with no feedback wave, there is a given amount of output signal and a given amount of unwanted distortion. If, now, negative feedback is gradually introduced in increasing amount and at the same time the incoming signal is increased by an exactly corresponding amount, the voltage effective on the grid due to the signal alone remains unchanged, and, therefore, the signal output remains unchanged in amplitude. By virtue of the negative feedback, however, some of the distortion is being fed back to the grid in such sense as to reduce the distortion appearing in the output. The result is less distortion with no diminution in signal output, a new improvement in linearity of the circuit.

The apparatus for increasing the negatively fed-back wave might be visualized as an amplifier of variable gain. Likewise, the apparatus for producing a corresponding increase in the signal input may be thought of as an amplifier of variable gain. Since the coordinated changes assumed to take place in these two amplifiers are a simultaneous increase in their amplifications by exactly equal amounts, the next step is to visualize these two amplifiers as one and the same amplifier through which both the incoming signal and the feedback wave are transmitted. This amplifier can be pictured as introduced just ahead of the existing amplifier, but after the junction of the incoming and the feedback circuits.

Thus the distortion in a given cir-

cuit can be reduced relative to the signal by first adding a negative feedback and then adding to the total gain of the amplifier, still keeping the amplitude of the signal effective on the grid of the final tube the same as before and, consequently, the signal output the same. In other words, the gain in the amplifying path is increased but the increase is nullified by a negative feedback.

The more important transmission features obtained by the use of a stabilized feedback circuit are:

1. Improved stability of gain and amplification.
2. Improved modulation.
3. Improved linearity (gain independent of input).
4. Improved and stabilized impedances.
5. Improved phase shift.
6. Reduced phase distortion.
7. Reduced variation of gain with frequency.
8. Reduction of noise generated within the amplifier or from power supply circuits.
9. The possibility of delivering constant voltage or constant current to a varying load or output impedance.
10. Reduction in the susceptance of the circuit to external fields or interference.
11. Improvement in load carrying capacity.
12. Practicability of using less precise and hence usually cheaper circuit parts without sacrifice of performance or reliability.

## Stabilized Feedback for Radio Transmitters

By L. G. YOUNG

Radio Department, Bell Telephone Laboratories

VERY MUCH simplified schematic of a radio transmitter might be represented as shown in Figure 1, where a rectifier is connected to the final stage so that a portion of the output will be available for comparison with the input. For simplicity it may be assumed that the input is a single frequency, and under these conditions the input and output voltages could be represented as shown in the lower part of the illustration—the amplitude of the rectifier output being adjusted so that

## Bibliography

### Articles on Stabilized Feedback by Bell System Engineers

- REGENERATION THEORY by H. Nyquist  
*Bell System Technical Journal*; January, 1932; p. 126
- STABILIZED FEEDBACK AMPLIFIERS by H. S. Black  
*Electrical Engineering*; January, 1934 p. 114
- FEEDBACK AMPLIFIERS by H. S. Black  
*Bell Laboratories Record*; June, 1934; p. 290
- STABILIZED FEEDBACK by H. S. Black  
*Pick-Ups*; July, 1936; p. 12
- STABILIZED FEEDBACK FOR RADIO TRANSMITTERS by L. G. Young  
*Bell Laboratories Record*; February, 1937; p. 182
- STABILIZED FEEDBACK OSCILLATORS by G. H. Stevenson  
*Bell System Technical Journal*; July, 1938; p. 458
- THE APPLICATION OF NEGATIVE FEEDBACK TO FREQUENCY MODULATION SYSTEMS by J. G. Chaffee  
*Proceedings of the Institute of Radio Engineers*; May, 1939; p. 317  
*The Bell System Technical Journal*; July, 1939; p. 404
- FREQUENCY MODULATION — THEORY OF THE FEEDBACK RECEIVING CIRCUIT by John R. Carson  
*Bell System Technical Journal*; July, 1939; p. 395

the fundamental frequency has the same value as that of the input to the transmitter. This input voltage is marked  $E_g$ , and the corresponding output voltage of the rectifier, although

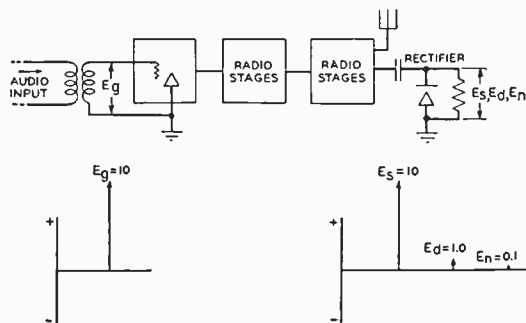

Fig. 1—In the output of a radio transmitter there are distortion and noise components in addition to the desired signal.

equal to it by adjustment, is marked  $E_s$  to indicate that in general it is different from that on the grid of the input stage.

Two other voltage vectors are indicated in the output—one,  $E_d$ , representing the distortion voltage, and the other  $E_n$ , representing the noise voltage that is generated within the transmitter itself.

Although  $E_d$  and  $E_n$  are practically always generated in the final stage of the transmitter, the effect is exactly the same as if these voltages were produced

at the grid of the first tube, and the rest of the transmitter were free from distortion and noise. Thus if equivalent voltages  $180^\circ$  out of phase could be introduced into the grid circuit of the first tube along with the signal voltage, the distortion and noise would be cancelled out and the transmitter would be perfect. The principle of stabilized feedback is thus to carry back to the input of the transmitter a portion of the output in reversed phase, so that the distorting elements in the output will be cancelled by similar but negative voltages.

Actually, of course, the full value of the distortion cannot be completely cancelled, for if it were there would be none of the distortion remaining in the output to be fed back. There must always remain a vestige of the distortion in the output that may be adjusted to the proper value and then fed back to the input.

The various relationships involved may be illustrated for the moment by considering the harmonic distortion alone, and assuming that without feedback the distortion was 10 per cent of the signal in amplitude, and that it is desired to reduce it to 1 per cent. This ratio of final to initial distortion defines the amount of feedback required. The distortion under feedback conditions will be equal to the original distortion plus the distortion fed back, which is in phase opposition to the original distortion, and thus the amount of distortion to be fed back will be equal to the difference between the original and final distortion. Thus, if the original distortion was 1 volt and the final distortion is to be one-tenth of that amount, or 0.1 volt, the amount of feedback will be  $-0.9$  volt, or nine times the final distortion and in opposite phase.

The feedback circuit, however, picks up not only the harmonic-distortion components but the noise and the signal components as well, and all will be reversed in phase and equal to nine times their final values in the output circuits. The purpose of feedback, however, is to reduce the noise and distortion without reducing the signal, but it is obvious that if a signal nine times the original and in opposite phase were fed back, the amplitude of the input signal would have to be changed in order to keep the output signal the same. In other words, the input signal

(Continued on page 36)

## Western Electric War Production Zooming

*(Continued from page 3)*

high with crates and boxes marked "Radio Tubes", "Command Sets", "Delicate Electrical Apparatus". Looking down from the fourth floor you see the giant crane dangle its chains over a cluster of cases — clutch one in its iron claws — swing it high in the air then trolley along to the end of the platform. Back and forth it glides — carrying tons of equipment which soon will follow other Western Electric war shipments rolling over the country by rail and truck.

A freight car switched into the plant from a nearby siding is being loaded with oblong crates and neat square boxes marked "Fragile" in bold black letters. As you watch men sealing the doors you wonder what secret devices have been packed away in the car and where it will travel. But new inventions and destinations, you learn, are zealously guarded by the few who know at the plant.

Leaving this area your guide escorts you on through other sections of the building. You must travel a round-about route since the various restricted areas are accessible only through certain stairways and doors. As you pass from one department to another special guards posted at numerous locations stop you to check on your badge. "Why are you here — where are you from?" they want to know. And you meekly tell all, heaving a little sigh for the happy days when you could walk through these same aisles without feeling like a case of smallpox. However, being heart and soul for the good old democratic way of life, momentary annoyances disappear and you are grateful to witness this example of American industry's vigilance.

During the tour you are told that Western Electric is purchasing much of its material and various parts from other suppliers, thus sharing Uncle Sam's orders and speeding up production. Approximately 40 per cent of the work has been sub-contracted — scattered among hundreds of firms. All incoming materials are carefully inspected and tested to make sure that specified standards have been maintained. Many new employees especially trained for the work have joined the forces to handle these preliminary checking and

testing operations. You see groups of men at their micro-projectors, microscopes and Q-meters determining the accuracy of the various parts. In keeping with Western Electric's precision workmanship tolerances allowed are extremely small — in some cases a plus or minus of only .0005 inch.

Back of a sign reading "Poisonous and injurious substances" you watch rows of operators, wearing goggles, heavy rubber gloves and floor length aprons, dipping aviation radio parts into bubbling chemical baths. Two men in nearby booths look as though they were all set for a gas attack, but the strange contrivance worn over nose and mouth, you are told, are not gas masks but respirators. The men are spraying enamel on metal housings and the respirators protect them from injurious fumes.

One of the most interesting manufacturing operations in the shop takes place in an infra-red ray tunnel used for baking enamel. Twenty feet long the tunnel contains 64 lamps which create a temperature of 425 degrees Fahrenheit in the metal. This bakes the enamel finish from the inside out as various radio parts travel through the enclosure on a slowly moving chain conveyor.

In a nearby section you notice a group of pretty girls engraving code letters and control and operating information on command set cases. How deftly they handle the big machines and how perfectly the neat white characters stand out on the enamel finish! Certainly Uncle Sam's flyers will have no difficulty in recognizing the insignia on their control knobs. Hundreds of girls are working on war equipment, you learn. Because of their tapering fingers, they can handle many of the more delicate manufacturing processes better than men whose hands are shorter and less dextrous.

Further along you stop before a row of furnaces, fascinated by the quick tongues of flame which dart out every few seconds from the deep crimson ovens. These operators, your guide explains, are tempering permanent magnets. Using long handled tools shaped like nut crackers they slide the pieces of steel on to the hot plates — flap them over like pancakes — haul them out red hot — drop them into an oil bath where they sink to the bottom of the tank with a prolonged sizzle.

Entering the wiring and assembly department you see row after row of

men and women earnestly engaged in drilling, riveting, soldering, wiring. Thousands of tiny parts like pieces of a jigsaw puzzle fall into place under the guidance of well-trained fingers. A mass of seemingly unrelated materials take form before your eyes. From one pair of hands to the next in line the units travel steadily down the long tables. Frameworks are erected, housings fitted, chassis wired, circuits tested and the finished products crated and hauled off to the loading platform — a continuous parade passing through the shops with clocklike precision.

In the course of the tour you discover that even your exclusive badge will not admit you to certain areas. All is hush-hush — and you reluctantly pass by with your curiosity completely unsatisfied. Even the men working in these particular sections do not know how or where the equipment they are building will be used by our armed forces. Blueprints, you learn, are guarded with the greatest precaution and locked away when not in actual use.

Throughout the trip you are impressed, as one always is who visits this plant, with the accuracy and durability of the craftsmanship. How priceless now the long years of Bell System research and development! How wise those laboratory experts who aim always for something better! Never in its history have Western Electric's high manufacturing standards assumed such importance. For this radio equipment is playing one of the most vital roles in America's great battle. On bombing and fighting planes, on tanks, on battleships, cruisers, destroyers and submarines and with the forces on land it must do a perfect job.

---

## W71 NY, New York, N. Y.

*(Continued from page 18)*

result in decided advantages to the audience and in quality rating for broadcasters. Mr. Streibert believes that it opens up the way to a new age of program specialization whereby stations will come under program topical headings. One FM station will be known for its symphonic music, another for swing and dance tunes, a third for news, and so on. According to Mr. Streibert this is not practical on AM although in a limited way some broadcasters have attempted it.



## How to Increase Tube Life

(Continued from page 11)

the plate voltage has been removed. Five minutes operation at lowered voltage will reduce thermal shock caused by sudden cooling. During operation, welding temperatures sometimes occur to wrench the filament out of shape.

Follow the above procedure for air cooled tubes also, but leave the blower on for a minute after the filament has been turned off.

If mercury vapor tubes are operated at ambient temperatures of 20° C. or lower, extra time is required on starting for the mercury vapor to reach a satisfactory pressure. For example, the manufacturer recommends the following for 266-B tubes.

For ambient temperature of 10° C. preheat 5 minutes

For ambient temperature of 5° C. preheat 10 minutes

For ambient temperature of 0° C. preheat 15 minutes

At WOR we have discontinued the practice of preheating mercury vapor tubes at half voltage as we believe that this poisons the tube.

Mercury vapor tubes on the shelf should be heated for one or two hours every *three months* to insure satisfactory operation when put into service. If allowed to remain inactive for a long period of time without treatment, they have been rendered useless by the mercury vapor diffusing slowly into the pores of the anode or cathode.

Tubes of this type should be kept in an upright position to prevent mercury splashing onto the anode and cathode. If this should occur, the tube must be preheated long enough to vaporize the mercury from the elements and condense it at the bottom of the tube. The lower end of the tube should be cooled by natural air circulation or by a thermostatically controlled blower to obtain proper condensation of the free mercury.

### COOLING SYSTEM EFFICIENCY

Accumulation of scale on water cooled tubes and in the water system should be avoided. Scale is a poor conductor of heat. When it forms on the anode, less heat is dissipated and the comparatively rough surface breaks up the smooth sheet of water flowing over

the plate, causing localized boiling. Overheating of the anode may result.

A piece of scale is often the cause of water whistles. Reflushing the water system through the storage tank during off-the-air periods will usually dislodge the scale from the tube and eliminate the whistle. Water whistles, as a sign of an overheated anode, have caused tube plate distortion, which makes it difficult to remove the tube from its socket. Therefore, the whistle should be used as a guide to proper maintenance.

In many stations it is the practice to remove tubes from their sockets after 1,000 to 5,000 hours of operation in order to remove scale and test the spares. There has been much discussion on the advisability of this procedure. We have found that some tubes can be removed easily after as long as 18,000 hours, while others with but 5,000 to 10,000 hours are difficult to remove because of scale. Experience has shown that after several thousand hours of operation, tubes are usually jarred when removed from their sockets, with occasional breaking of grid laterals. When these tubes are reinserted in their sockets, flash arcs result invariably. These flash arcs pit the filaments, removing some tungsten, which results in shorter life.

At WOR a tube is never taken out of its socket simply to test another tube. We have weighed the matter of scale accumulation versus jarring and flash arcs, and have chosen to put up with the scale as the lesser of two evils. By leaving tubes in their sockets, we find that the filaments open clean and do not short out the grid circuit. This keeps the transmitter on the air and allows replacement after shut down.

Since it is recommended that final amplifier tubes remain in their sockets until they burn out, methods must be devised for removing scale from tube plates and sludge from rubber hoses and other parts of the water system.

Sludge and residue in the system can be removed with tri-sodium phosphate, available in any paint store, or a commercial product known as "Oak-ite." After the water in the system has reached a temperature of 160° F., we remove two tubes, preferably from the second power amplifier stage, pour two pounds of the chemical into the sockets and dissolve with boiling water. Then we insert the tubes in their sock-

ets and flush the chemical solution through the system for one hour with filaments on and the water at approximately 140° F. This will remove an amazing amount of sludge and residue.

We make sure to again flush the system thoroughly with distilled water before final refilling. The amount of leakage current flowing before final filling will indicate how successful the flushing has been. The complete routine procedure used at WOR in cleaning the transmitter water system will be sent to any engineer upon request.

We find the following procedure is helpful in removing accumulated scale from a tube:

Mix a 20 per cent solution of muriatic acid by first pouring eight glasses of water into a stone crock, then slowly adding two glasses of acid. *Never pour water into the acid* as this will cause boiling and spattering and possible acid burns. Stir with a wooden stick and avoid inhaling the fumes. Fold a small rag into a three inch square and wet this in the solution. (In its diluted state the acid will not injure the hands.) Rub the rag gently over the scale on the tube. Repeat the operation until the tube is clean.

**Caution:** Do not clean above the clamping ring on the tube plate and do not drip acid on the glass seal. The bottom of the tube may be rested on the bottom of the crock, but hold the tube so the glass seal does not lie against the rim. When finished, be sure to wash the hands with warm water and soap.

### EFFICIENCY OF TRANSMITTER, MAINTENANCE, and ASSOCIATED PROTECTIVE RELAYS

Tube life can be increased by operating the various radio frequency stages at highest efficiency. Water flow relays and overload dc relays should be checked and adjusted at least twice a year. Contact points and relay bearings should be carefully maintained.

### CARE OF SPARES

Store all tubes where they will be free from mechanical shock and excessive vibration. Keep in a vertical position, with cushion rings for the larger tubes. Protect glass parts from scratches.

Clean and test all spare tubes periodically — this is the most important precaution. This precaution includes

looking at glass presses and seals for cracks.

## TUBE TREATMENT

The foregoing has described the methods to be used in operating, handling and storing tubes in order to get the longest possible service from them. But what can be done with tubes that develop faults even when all these precautions have been taken?

At WOR we have several special methods of treating tubes. They can be outlined as follows:

1. Tube Reconditioning:
  - a. Clean up gas in tubes with rated plate potentials above 8,000 volts.
  - b. Trace faults in both low and high voltage tubes.
2. Filament Aging:
  - a. Clean filament and grid surfaces and remove residual gas from tungsten filament air or water cooled tubes.
  - b. Condition thoriated tungsten amplifier and high vacuum rectifier tubes.
3. Filament Preheat Test
4. Test at Maximum Plate Voltage

## TUBE RECONDITIONER

A common problem confronting engineers is the tube which becomes gassy, either from shelf wear or during use in the transmitter. There are only three alternatives — discard the tube, return it to the manufacturer for adjustment, or treat it yourself. The first of these is expensive and unnecessary. In returning tubes to the manufacturer, packing and shipping is a problem, and there is a chance of damage to elements and glass parts. It is much better to invest one or two hundred dollars in a reconditioner which cleans up gaseous tubes in a few minutes, adds considerably to their life and thus saves many times its moderate cost in a few years.

The reconditioner treats effectively all types of tubes operating at plate potentials above 8,000 volts. It can be used also in tracing faults in lower voltage types. Spares can be tested to eliminate any chance of a faulty tube being placed in service and tubes which become gassy while in the

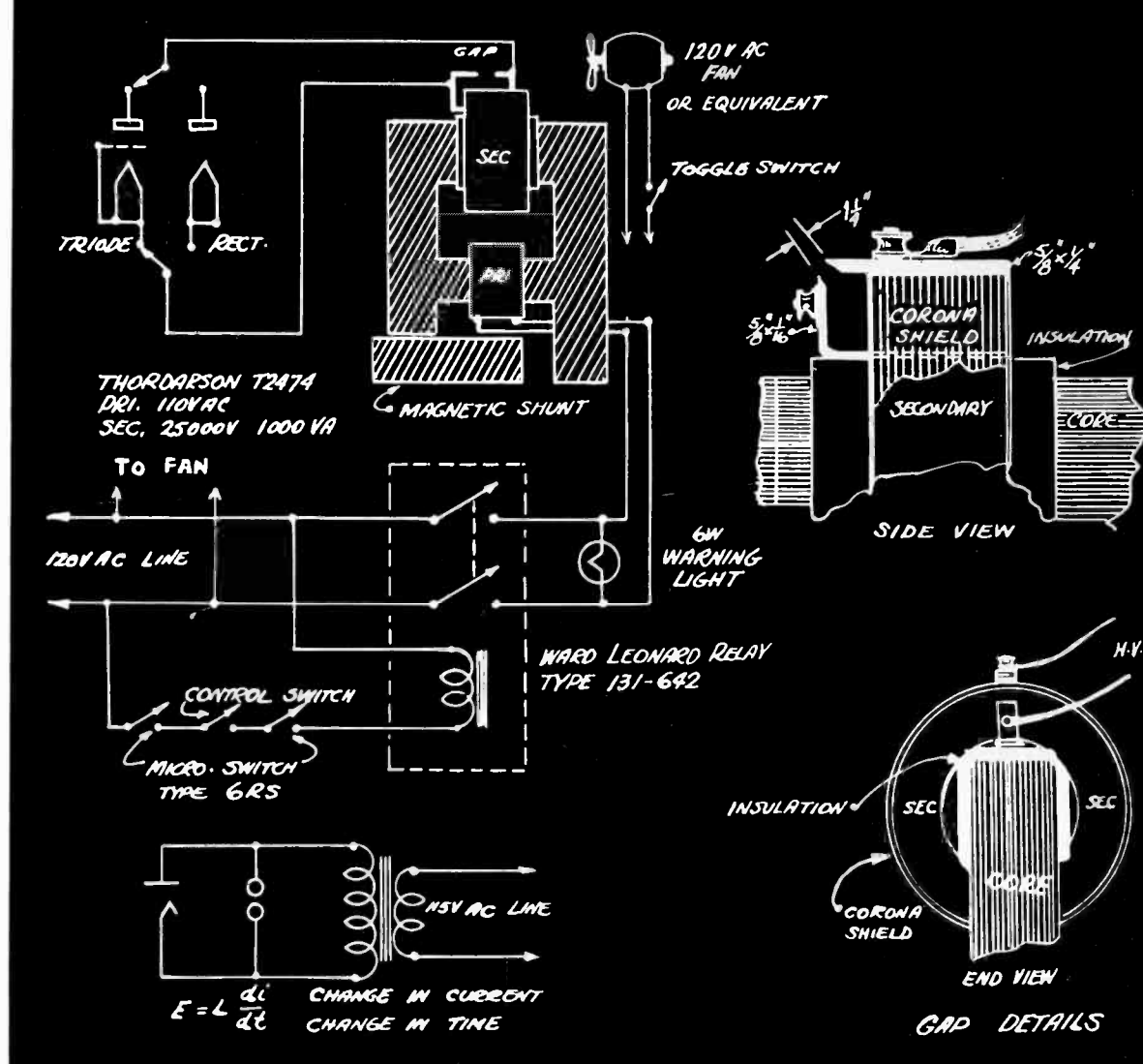

Schematic diagram of WOR's tube reconditioner, used for cleaning up gaseous tubes

transmitter can be cleaned up or "degassed" and returned to normal operation. Here is an example from our experience:

One of the Western Electric 342A water cooled tubes in the power amplifier of WOR's 50 KW transmitter developed a series of flash arcs after 5,000 hours of filament life. The auxiliary transmitter was switched into service, the tube in question was removed from the circuit and treated in the reconditioner. At the close of the broadcasting day the tube was returned to its original position in the transmitter.

It operated normally for 1,000 additional hours before it again developed the tendency to flash arc. It was removed, reconditioned and put back into service a second time. It continued to operate properly until it finally burned out at the ripe old age of 18,386 hours. This is but one of many cases of greatly increased tube life resulting from the use of our reconditioner.

When mercury vapor rectifiers haze up and cause occasional arc backs they can be treated in the same method. After treatment, if the haze disappears, the tube is ready to go back into service.

Construction of our unit is simple — a complete list of parts being shown on the accompanying schematic diagram. The transformer was purchased for about \$70.00 and the entire reconditioner was built for about \$100.00. The photograph on the following page may serve as a guide to the placement of the parts.

Operation of the reconditioner is as follows:

Alternating current, 115 to 120 volts, is applied to the primary winding of the transformer, which induces a high voltage in the secondary. This induced voltage is applied to the tube between filament and grid tied together and the anode. When gas ionization is present in the tube, the current in the secondary increases suddenly. The applied voltage drops momentarily, due to transformer reactance, which breaks the internal arc. The sudden change of current develops an e.m.f. of sufficient magnitude to break across the protective gap, thus indicating that the tube has flashed. The internal flashing of the ionized gas in the tube either cleans it up or reorients it on the electrode surface.\*

\*"The Thermionic Tube and Its Application" by Van der Bijl.

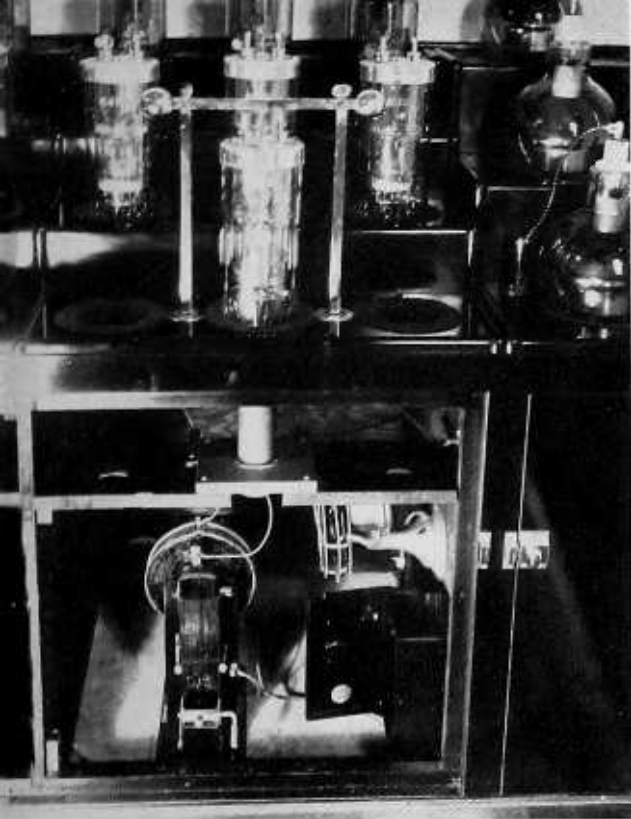

Interior view of WOR's tube reconditioner

As previously pointed out tubes may become gaseous through shelf wear or the residual gases, such as mercury vapor in the case of rectifier tubes, may redistribute themselves on the electrode surfaces. Should the potential difference between electrodes become large enough to cause a flash arc, the residual gas molecules are broken up into positively and negatively charged ions. The former are attracted to the cathode — the latter to the plate. The positive ions are momentarily absorbed in the negatively charged electrodes and the negative ions are absorbed in the positive electrodes. A chemical action may even take place.

In the reconditioner, the filament or grid may form either the negative or positive element, depending upon which half of the cycle the flash arc occurs, while the plate assumes the opposite charge. Since the filament is not lighted, no electrons, except from so-called field current or cold emission, can help form a breakdown path which results in a flash arc. Thus when a flash arc occurs with the filament off, it must be the result of conduction gases or metallic vapors which are the positively and negatively charged ions in the tube itself.

The ions are bombarded against the plate, grid and filament. They hit so hard that they may be absorbed in the elements themselves and can only be released again by excessive heating. Sometimes this gas is never released, and thus can do no harm.

In practice, this is the routine fol-

lowed at WOR in operating the equipment.

1. After checking to insure that the control switch is in the "OFF" position, carefully insert the tube in the socket. Be certain that the shorting bar across filament and grid terminals makes a good connection. In the case of high voltage rectifier tubes, be sure that filament leads are shorted.

2. Switch "ON" the fan in the transformer compartment.

3. Set the transformer in the low voltage position by putting the magnetic shunt all the way in, thus shortening the magnetic path of the lower leg of the transformer and by-passing a considerable portion of the flux.

4. Close the transformer compartment door, leave the tube room and turn the control switch to the "ON" position. If an arc sustains across the transformer gap, break it by snapping the control switch to the "OFF" position. Switch "ON" again and leave on low voltage for one minute.

5. Throw the switch to the "OFF" position. Go into the tube room and put the transformer in the high voltage position by placing the magnetic shunt all the way out which concentrates the magnetic path through the secondary of the transformer.

6. Leave the tube room and turn the control switch to the "ON" position. If an arc is formed across the gap, break it by throwing to the "OFF" position. Condition the tube on high voltage for 10 minutes after the last flash.

Best results will come from the reconditioning process if tubes are treated immediately before being inserted in the transmitter tube socket. If this is done no flash arcs or arc backs will occur during operation. At times the treatment of a stubborn case may take one or two hours. If the 10 minute treatment after the last flash does not clean up the condition, the tube has probably developed a leak which will cause trouble when put in service.

If the tube under test has a small amount of air in it, a pinkish color can be seen when the voltage is applied. This color is evident in mercury vapor tubes as well as in amplifier tubes, but is mixed with the blue color due to mercury vapor. If a tungsten filament type tube has a crack which lets it down to air, a yellowish smoke will appear in the tube when the filament is

lighted. This is a tungsten oxide formed from the filament burning in air.

We keep an accurate record of tube reconditioning on a special form. Space is provided for entering the serial number and type of tube, number of flash arcs observed on both low and high voltage, and time required for reconditioning. A condensed entry of this information is made in the log.

#### FILAMENT AGING

A second part of the reconditioning treatment which has been tried with some success consists of filament aging of thoriated tungsten filament tubes for 10 minutes with the filament voltage 30 per cent above normal, followed by one or two hours with normal filament voltage only — no plate voltage.

In order to age tungsten filaments of water cooled tubes, the tube must be placed in the transmitter socket with the standard water cooling conditions. The filament is lighted at the correct operating voltage as measured at the tube terminals. Lighting the filament at normal operating temperature tends to clear up residual gas and clean off the filament and grid surfaces. After one or two hours aging, the tube is ready to be tested in the transmitter under normal starting and operating conditions.

Even if your station has no reconditioner unit, we believe filament aging is still of some value. In a few instances the above treatment has been effective in reducing initial flashing during operation, even though the tube is again returned to the shelf for several weeks prior to being installed in regular service. It is recommended that spare tubes be conditioned by filament aging every three months to insure continuity of service. High vacuum rectifiers can be given the same treatment as amplifier tubes.

Unless a spare socket is available, this conditioning can be done during off hours when two tubes can be treated at the same time in the second power amplifier. In this way more than one spare is always conditioned and ready for use.

#### FILAMENT PREHEAT TEST

Due to long life, spare thermionic mercury vapor tubes usually remain on the shelf from 12 to 15 months. All mercury vapor tubes must be given a filament preheat test every three months for at least two or three hours



at the rated filament voltage. We have discontinued the old practice of preheating at one-half filament voltage. We feel it is better to be one or two per cent above the rated voltage than to fall below it.

In our transmitter we remove all rectifier tubes, install the spares and preheat for three hours. Then we test the circuit for operation under full load. Accurate records are kept of these preheat periods.

### TEST AT MAXIMUM PLATE VOLTAGE

If a mercury vapor tube fails to rectify without arc backs after the recommended preheating time, the following treatment may be beneficial.

A resistance bank of approximately 1 megohm (such as twenty 50,000 ohm, twenty watt resistance units) is inserted in series with the anode. The voltage is left on for at least one hour or until all visible mercury is removed from the anode. Air at room temperature should be blown on the lower end of the envelope during this treatment. The tube then is operated under standard conditions without the resistance for one or two hours.

## Stabilized Feedback

(Continued from page 31)

amplitude must be increased so that when combined with the feedback signal, the sum will just equal the original input.

Since the signal fed back in the example taken is minus nine times the output signal, the increased input signal must be ten times the original signal in order that the difference will give the same signal amplitude as existed before feedback was applied. If the original signal was 10 volts, the signal feedback will be minus 90 volts, and the increased input signal must be 100 volts so that the net final signal will be 10 volts, or 100 minus 90.

The amount the input signal must be increased under feedback conditions, or the ratio of input voltage without feedback to input voltage with feedback is numerically equal to the ratio of distortion voltage with feedback to distortion voltage without feedback, and for convenience is taken as the measure of feedback. The amount of feedback in db is thus twenty times the logarithm of the ratio either of the in-

put voltage without feedback to that with feedback, or of the final to initial distortion. In the example taken for illustration this ratio is 10, and thus there may be said to be 20 db of feedback.

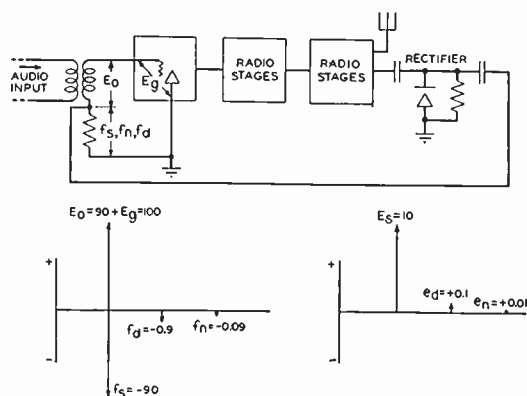

Fig. 2—Feedback returns to the input a portion of the output in reverse phase, and in this way cancels part of the output noise and distortion.

In Figure 2 is shown the same transmitter as in Figure 1, with the addition of the feedback circuit, and below it are the various voltages under feedback conditions. Small letters are used to indicate the reduced values of the noise and distortion voltages. The noise voltage with feedback, is in the same ratio to the original noise voltage as the distortion voltage with feedback is to the original distortion, all forms of distortion being reduced the same relative amount.

In practice, the phase difference between the input and feedback voltages can be made 180 degrees at one frequency only and the simple, ideal condition just depicted is not realized. It is the problem of the transmitter-circuit designer to control and manipulate the phase shifts and gains throughout the circuits involved so that the feedback and input voltages do not become in phase except at frequencies far removed from the transmitted band. The gain of the feedback loop at these frequencies where the voltages become in phase must be reduced to less than unity or singing will result. It is not always easy to apply feedback to a radio transmitter, but the results obtained with this arrangement cannot be achieved by any other known means as simple and economical.

## WHN Goes 50 KW

(Continued from page 12)

market when it was decided to boost the power. It is no mean job to size up all the factors involved in choosing a transmitter and the elaborate outlay of

associate apparatus — particularly a 50 KW system. Price, performance, maintenance, durability and innumerable other features must be weighed in the balance. Results of WHN's studies tipped the scales again in favor of Western Electric.

The equipment was installed under the supervision of Chief Engineer Paul W. Fuelling, who heads the following staff: Bernie Stahl, transmitter supervisor; William Brady, Frank Kearney, Gabe Rumble, Al Mahler, Grover Wizeman, Harold Kane, Carl Neuwirth, transmitter engineers; Edward Hopper, studio supervisor; Ike Cohen, Ben Lazarus, Otto Kornthauer, John Turner, Michael Ebert, Carl Young, Sanford Alper, William Durkin, Frank Anzalone, Meylert McIntire, Earl Gordon, Edward Greco, Arthur Olsen, Leon Wortman, studio engineers.

## What's Happened to Rectifier Tube Costs?

(Continued from page 14)

ments, broadcasting engineers can do their share to increase tube life by controlling filament voltage or temperature and thus retard evaporation rate of the tungsten. In this issue of PICK-UPS, Charles H. Singer, Technical Supervisor of Transmitters at WOR and its FM station W71NY, describes a simple, inexpensive conditioner which has added many hours of service to their air- and water-cooled tubes. This can be used to prolong the life of gaseous tubes, to detect faulty ones, to prevent flash arcs and to condition idle tubes before they are put into operation. Water-cooled high vacuum rectifiers such as the 222, 233 and 237 types can be treated in the same manner as amplifier tubes.

The most versatile of the newer tubes is the multi-purpose 357A (PICK-UPS, July 1939), with a rating of 350 watts plate dissipation and operating at full voltage up to 100 mc. The 357A, introduced for use in the high efficiency 1 KW AM broadcasting transmitter, has been added to the designs of Western Electric FM transmitters from 1 to 50 KW. Demand for these tubes has reached international proportions with an unprecedented volume of orders coming from outside the boundaries of the U. S. A. In the specialized and increasingly important field of the extremely high frequencies, Western Electric tubes are acknowledged leaders.

# THEY DO IT THIS WAY

How do you do it? Pick-Ups invites all engineers to send in items for this page.

## Adapting Vertical Pick-ups to Limited Space

When we installed two 9A re-producer assemblies recently, we were confronted with the problem of what to do with the two vertical pick-ups which the 9A's replaced. The only turntables with which they could be used were in a mobile sound truck, already equipped with two crystal low pressure pick-ups. However, the space available on this truck for mounting the vertical units was too small.

To fit the pick-ups into the limited space, several changes would have to be made. The overall length of each arm would have to be shortened and the arm axis moved up to keep the stylus pressure low. A special type of mounting would be necessary to obtain as long a radius of swing as possible and to maintain the head tangent with the groove at all diameters.

We went to work by stripping the arms down and shortening them two inches. The axis was then moved forward toward the head three inches and the new mounting checked for diameter tangency. It was found that an angle of 17 degrees would allow the head to track tangent at all diameters. A "V" cut was made on the inside of the arm just behind the connecting terminals and the arm was bent and soldered, making it as strong as it was originally. A substitute weight was placed on the completed arm to determine the amount needed for proper stylus pressure. We trimmed the original weight

to approximately the correct amount and then assembled the arm. To obtain perfect balance, the weight was shaved down with a fine file.

Because the pick-up output was quite small and required considerable amplification, any vibration originating in the machine would be picked up by the vertical head unless some suitable method could be found to absorb the vibration before it reached the arm. We solved this difficulty by mounting the arms on one inch felt pads.

We encountered an electrical problem caused by using both lateral and vertical pick-ups on the same truck, with only two faders available and no space for mounting others. In addition, we wanted to keep the equipment as flexible as possible and simple enough for an announcer to operate, if necessary. By adapting the equipment originally supplied with the vertical pick-ups and making a few minor changes, the trouble was eliminated. The faders were replaced by Daven 500/250 ladder pads having 30 steps and variable through 345 degrees.

The truck is mounted on large casters and can be moved around the studios at will. A line to the control room and an AC circuit are the only connections necessary. Contained in the truck are the necessary amplifiers, power supply, loud speaker, equalizers, fading and mixing systems, etc. It is used for sound effects, auditioning, preparing programs for sponsors and for presenting air shows. Operation since the installation of the vertical pick-ups has been very satisfactory. Not only did we

increase the value and usefulness of the sound truck, but we found a good place for two discarded vertical pick-ups.

BERNARD T. WILKENS, chief engineer  
WKBN, Youngstown, Ohio

## Portable Microphone Switching Panel

The accompanying diagram shows the panel we use here at KGFx to convert a four channel mixer into one capable of handling eight microphones, either individually or in pairs.

The switches were designed as shown, with the mike out of the circuit

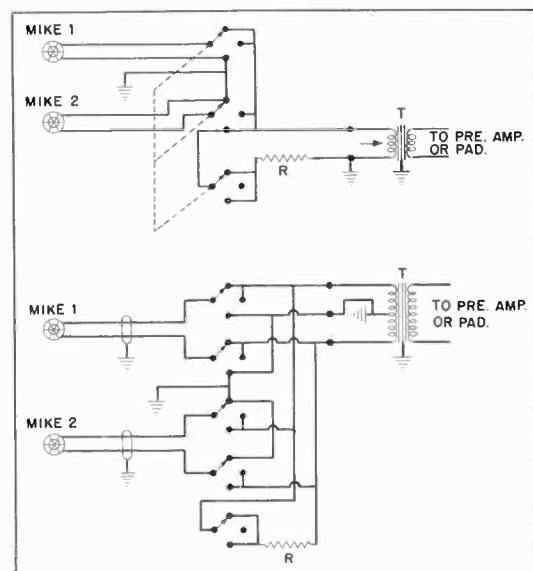

grounded. We thought switch clicks might occur when the gain was up but we have not encountered this difficulty, probably because static is kept drained off the mikes when out of circuit. The panel was put into use as soon as it was wired so we have had no opportunity to open the circuit and find out if this is actually the case.

The device is used in our studio and on remote jobs and it takes only a few minutes to connect the amplifier. Input and output terminals may be made to suit individual station needs.

3 pole triple throw switch for single wire shielded mike cable

Imp. Z of T = 1/2 mike Z

R = mike Z

5 pole triple throw switch for 2 wire shielded mike cable

Imp. Z of T = 1/2 mike Z

R = mike Z

One switch per mixer control

Switch position 1 = mike 1 on

Switch position 2 = both mikes on

Switch position 3 = mike 2 on

ROBERT H. DYE, chief engineer  
KGFx, Pierre, S. D.



PICK-UPS

# Western Electric Man Cited by Navy For Work at Pearl Harbor

**I**N A LETTER from the Chief of the Bureau of Ships, Navy Department, Burdett Packard Cottrell, Western Electric Specialty Products field engineer, has been cited for unusual "diligence and zeal" in the performance of his duties in connection with servicing installation of Western Electric equipment aboard naval vessels at Pearl Harbor during and following the Japanese attack of December 7, 1941. The letter quotes from the Pearl Harbor Navy Yard commandant's letter to Mr. Cottrell, commending him for services far above those normally required of civilians.

The text of the letter to Western Electric from the Chief of the Bureau of Ships is as follows:

NAVY DEPARTMENT  
BUREAU OF SHIPS  
WASHINGTON, D.C.

From: The Chief of the Bureau of Ships  
To : The Western Electric Company,  
Kearny, New Jersey  
VIA : The Inspector of Naval Material,  
New York

ATTENTION: Mr. F. R. Lack

SUBJECT: Appreciation for Diligence  
and Zeal in the Performance  
of Duty.

1. The Bureau of Ships is in receipt of a copy of a letter from the Commandant, Navy Yard Pearl Harbor, T. H., and addressed to Mr. B. P. Cottrell, special representative of the Western Electric Company. This letter is quoted herewith for your information:

"The Commandant notes that during the period from December 7, 1941, to December 13, 1941, you performed your duties at this Navy Yard in an exceptionally diligent and zealous manner and were on duty during that period a total of eighty-four (84) hours and forty-five (45) minutes.

The service which you rendered during the above period of time was highly necessary in the interest of the fighting efficiency of the Fleet.

The Commandant is pleased to commend you for the performance of

this duty which is considered to be over and above that normally required of civilian contract employees."

2. It afforded the Chief of the Bureau of Ships a great deal of pleasure to receive the above report. This example of good American spirit is typical of the manner in which Western Electric Company engineers have been undertaking their duties in connection with the installation and servicing of equipment in U. S. Naval vessels.

A. H. VanKeuren  
Chief of Bureau of Ships

Mr. Cottrell joined Electrical Research Products Inc. in 1929, as an installation engineer. He remained with ERPI until 1935, rising to the post of superintendent of operating planning at the Company's New York headquarters. Last year he took up his present duties with the Specialty Products Division. He is a graduate of the University of Arizona and has a Master of Science degree in Electrical Engineering from Massachusetts Institute of Technology. Mr. Cottrell makes his home in New York City.

## Radio and Sound Equipment

(Continued from page 23)

of 90 degrees and a vertical angle of 60 degrees.

In combination with a 722A receiver it will cover a frequency range from 500 to 6500 cycles. The loud speaker thus formed will handle the full undistorted output of a 25 watt amplifier when reproducing speech or music with frequencies around and below 500 cycles sufficiently attenuated and will provide an intensity level of approximately 76 db above  $10^{-16}$  watt per square centimeter at a distance of 100 feet on the axis of the horn. Combined with a 713A Receiver the new horn will cover a frequency range from 500 to 10,000 cycles. The loud speaker thus formed will handle the full undistorted output of a 25 watt amplifier when reproducing speech or music with frequencies around and below 500 cycles sufficiently attenuated and will

provide an intensity level approximately 78 db above  $10^{-16}$  watt per square centimeter at a distance of 100 feet on the axis of the horn.

## KTAR Most Powerful Station in Arizona

(Continued from page 29)

whose campus the Arizona Broadcasting Company originates five non-commercial programs weekly. Another aspect of the station's educational programming is KTAR's School of the Air which offers classes in English and Spanish.

Religious programs released by the station are headed by a five-time-a-week series called the Morning Devotional. These broadcasts are under the direct supervision of the Phoenix Ministerial Association. Each Sunday morning a half hour is set aside for a Mexican church service which is devoted to the work of Protestant churches of the Spanish speaking people in the state. This has been a popular KTAR feature for many years.

The antenna system is a directional array by means of which power can be concentrated or limited in desired directions. This type of system represents one of the latest advances in radio engineering and, according to KTAR, is the first installation of its kind in the Southwest.

Dozens of years of experience form the background of KTAR's well trained staff of employees which is headed by Dick Lewis, general manager. Lewis also directs operations of the Arizona Broadcasting System. Since 1920 when he started with the Arizona Republic as a newspaper carrier, Lewis has been associated with the Arizona Publishing Company or its affiliated institutions. In 1929 he joined the staff of KFAD, forerunner of KTAR, when the publishing company and the Electrical Equipment Company joined forces for the creation of KTAR.

Top members on his staff are Arthur C. Anderson, chief engineer; J. Howard Pyle, program director; J. R. Heath, commercial manager; B. R. Fulbright, office manager and Paul Giroux, musical director. An outstanding pioneer in commercial broadcasting, Anderson has directed the technical operations of the station since its inception in 1922.



**REMEMBER  
PEARL HARBOR  
V  
OUR ANSWER  
PRODUCTION!**

*Western Electric Company*

