

# Indiana Historical Radio Society

## BULLETIN

Vol. 12

June 1983

No. 2

### *The Symphony*





### OFFICERS

President \* \* \* \* \* Frank Heathcote  
 1235 North 3rd St., Logansport, IN 46947

Vice President \* \* \* \* \* Jerald Hueber  
 6316 Winnebago Ct., Ft. Wayne, IN 46815

Secretary \* \* \* \* \* Jim Fred  
 R1, Box 41, Culter, IN 46920

Treasurer \* \* \* \* \* Marshall Howenstein  
 2741 North Salisbury, West Lafayette, IN 47906

Editor \* \* \* \* \* Jim Fred  
 R1, Box 41, Culter, IN 46920

Historian Ed Taylor  
 245 N Oakland Ave., Indianapolis, IN 46201

### FOR SOCIETY INFORMATION WRITE TO:

- Vice President - For legal matters of the I H R S.
- Secretary - For general correspondence and membership applications.
- Treasurer - For membership payments and address changes. (1982 I H R S membership dues remain \$6.00.)
- Historian - For history of the I H R S and for donations of material for the Society Scrapbook.

Please use a Self Addressed Stamped Envelope when requesting information.

Reproduction of this Bulletin or its contents is prohibited unless authorized by the Indiana Historical Radio Society.

# Auburn! 1983

The recent IFRS-AWA Meet in Auburn, IN appeared to be a huge success. From the Friday evening program to the Saturday evening banquet there was enthusiastic participation. The Flea Market had probably the largest number of open trunks and buyers of recent years. The Stanley Johnson items that were auctioned (as well as other consignments) brought record prices. Del Barrett and Ross Smith did a fine job of coordinating the entire event along with this writer. Bob Seivers, Mr WOWO, was his usual delightful self as he presented the slides of the "Colorful West" during the banquet. Ross Smith presented some outstanding slide shows on Tubes and Radiolas. A total of 157 individuals registered for the meet with some from as far away as Puerto Rico, Florida and the east coast.

Don Johnston, Paul Gregg and Al Jochem were the judges for the old equipment contest with Jerry Hueber as chairman. Don Johnston won the Grebe trophy for "Best of Show" with his magnificent Magnaformer 9/8. The other contest winners were: (1) Crystal Sets-1st place to Ed Taylor for his Leon Lambert Crystal Set; 2nd place to Joe Willis for his Tecla; 3rd place to Peter Yanczer for his crystal mount board and crystal pencil radio. (2) Regenerative Receivers-1st place ribbon to Eric Von Grimmenstein for his CR-12; 2nd place to George Hausske for his Tuska 225; 3rd place to Joe Willis for his Economy British Set. (3) T R F Receivers-1st place to Nelson and Tammy Preble for their A K model 9; 2nd place to Fred Schultz for his Grebe Synchrophase; 3rd place to Nelson and Tammy Preble for their Erla 550. (4) Superhet Battery Receivers-1st place to Don Johnston for his

AUBURN MEET  
(Continued)

Magnaformer 9/8. (5) All other Receivers-  
1st place to Lee Hagey for his Lyradion  
Receiver; 2nd place to Frank Heathcote for  
his EKCO Receiver; 3rd place to Fred Schultz  
for his Emerson Book Receiver.

It is hoped that next years contest will be  
even more successful. More contestants are  
needed in the Old Equipment Contest when  
more catagories will be judged.

Nelson and Tammy Prebel conducted the Horn  
Speaker Contest. It was interesting to  
hear the old horns play again. Bob Waller  
captured the 1st place ribbon; Ed Taylor  
won 2nd place and Fred Prohl received 3rd  
place.

Jerry Hueber  
Meet Chairman



# CANNON CRAFT

HINT -  
LAYOUT 11" X 20" RECTANGLE  
LOCATE BLOCK IN CENTER -  
USE AS TEMPLATE TO LOCATE  
PARTS  
I USED 14 TURNS # 22  
MAGNET WIRE - 18" X 10"  
1 1/4" ON WIDTH.

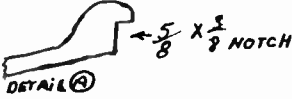
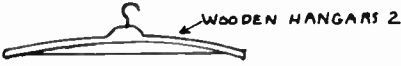

HARDWOOD BLOCK  
2 1/2" X 9" X 1"

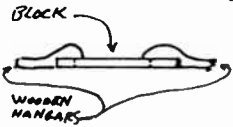
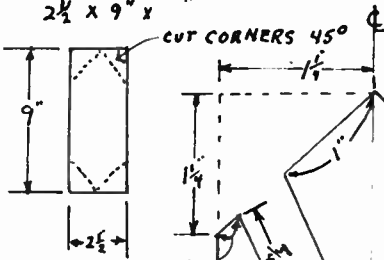

CUT NOTCHES FOR WIRE ON FLAT SIDE

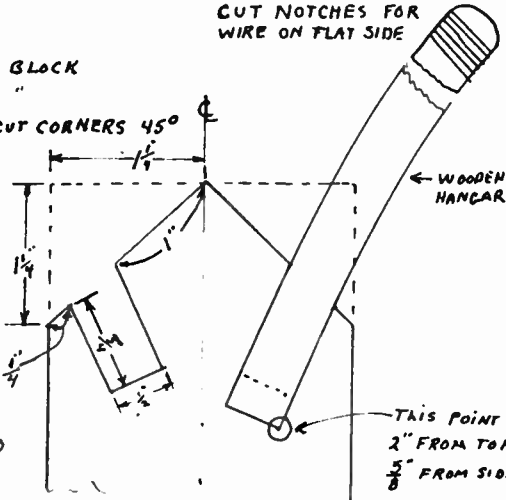

DRILL 3/8 ONE INCH DEEP ENLARGE TO 1/2" FOR DEPTH OF 5/8"

MAKE BASE TO SUIT NEEDS

DRILL 1/8 HOLES TO ACCEPT ANTENNA WIRE. THREAD WIRE THROUGH HOLES AND PEG TO KEEP ENDS FROM SLIPPING

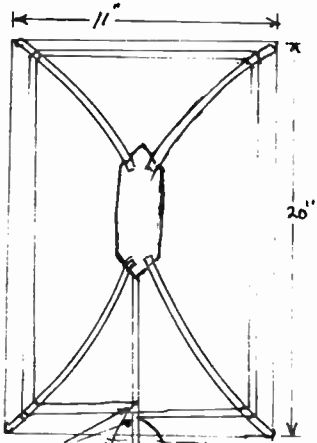
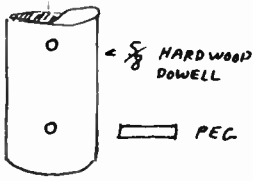

ANTENNA WIRE PEG

This Loop Antenna was designed and built by Rev. Robert Cannon, 11024 Manchester Rd., St. Louis, MO. It was submitted by Jerry Huber.



# AUCTION

As you may know our member, Stanley Johnson, passed away recently. There will be an auction sale of his collection. See the next page for time and place. Among the many items to be sold are the following.

Approx. 75 radios  
Nearly 75 horn, Drum, and Cone speakers, including 12 AK models H, L, M, E, F2 and a rare model R.  
2 IP 501's and IP 503 Loading unit  
DeForest Interpanel 3 tube receiver  
2 Federal model 61 receivers  
11 Atwater Kent breadboards  
Bunnell "Gold Bug" key  
Marconi "Bathtub" type SE86 key  
Five or more DeForest Tubular Audions  
Ferron Detector by Duck  
Rare Lyradion Receiver  
Sodium DR6 receiver  
12 cylinder phonographs and many parts  
12 Candlestick phones including a rare "Pot-belly" with long pole receiver.  
2 W. E. 7A amplifiers with tubes  
12 Crystal sets  
5 foot long phonograph horns  
15 Microphones  
His personal tube collection; consisting of 75 tubes made by Moorhead, Marconi, and DeForest  
10 or more Magnavox horns  
A number of separate drivers and parts  
A large assortment of Telegraph keys, Relays, and Sounders, including Bunnell 150, and others. Possibly 50 or more.

And many, many more items which space doesn't allow to be listed. The doors will open at 8:00 AM Saturday for inspection, with the sale to start at 10:00 AM

AUCTION

AUCTION

AUCTION

Place: Shiloh Reception Hall  
Carroll Road, Fort Wayne, Indiana

Date: June 11th and June 12th

See TRI-STATE TRADER for specifics

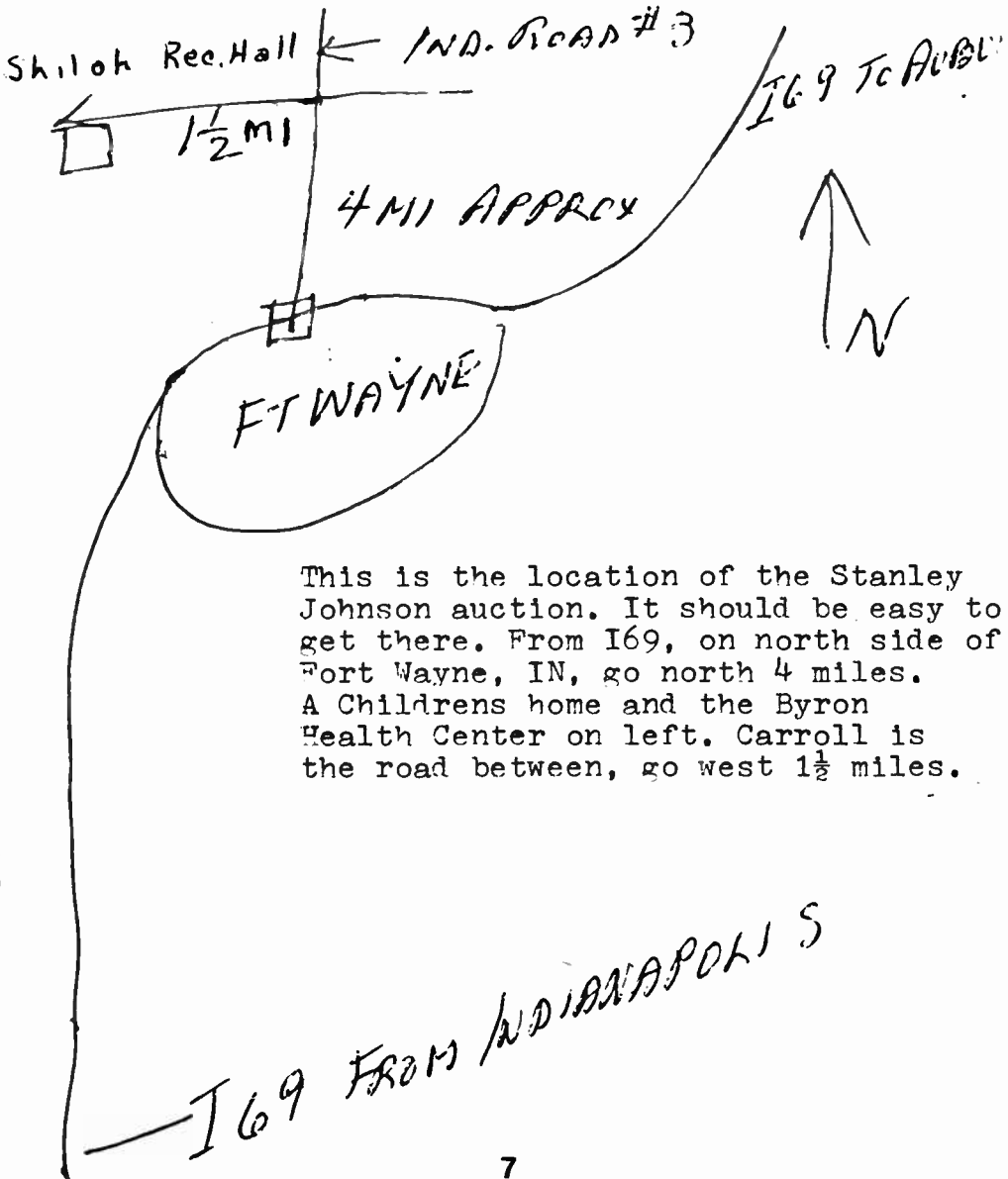

This is the location of the Stanley Johnson auction. It should be easy to get there. From I 69, on north side of Fort Wayne, IN, go north 4 miles. A Childrens home and the Byron Health Center on left. Carroll is the road between, go west  $1\frac{1}{2}$  miles.

# ELMCO

Back in the Dec. 1981 IHRS Bulletin I submitted catalog descriptions of some ELMCO (Electric Machine Corp., Indianapolis) apparatus. One of the complete receivers has now surfaced (I'd say "has been discovered" but of course it existed all along, in a Pennsylvania collection recently sold) and it is pictured here. Also, I found an ad for ELMCO equipment in RADIO magazine for June 1922, describing the individual units listed in the Dec. 1981 IHRS article, but not this one-tube receiver. Probably the receiver dates just a bit afterward.

There are minor differences between the actual set and the catalog illustration--an extra jack, post, and the relocated coil--but in general they are the same. I might note that the binding post nuts on my set are not original; I added some that closely matched the ones already there, but the catalog shows insulated caps. Inside, ELMCO used a large number of molded-composition parts, which look cheap but have stood up well with time. Both panels were originally identical when etched, and were drilled differently at assembly (they are aluminum, with etched black background).

I wonder what, if anything, the Electric Machine Corp. made before they got into radio?

Alan Douglas

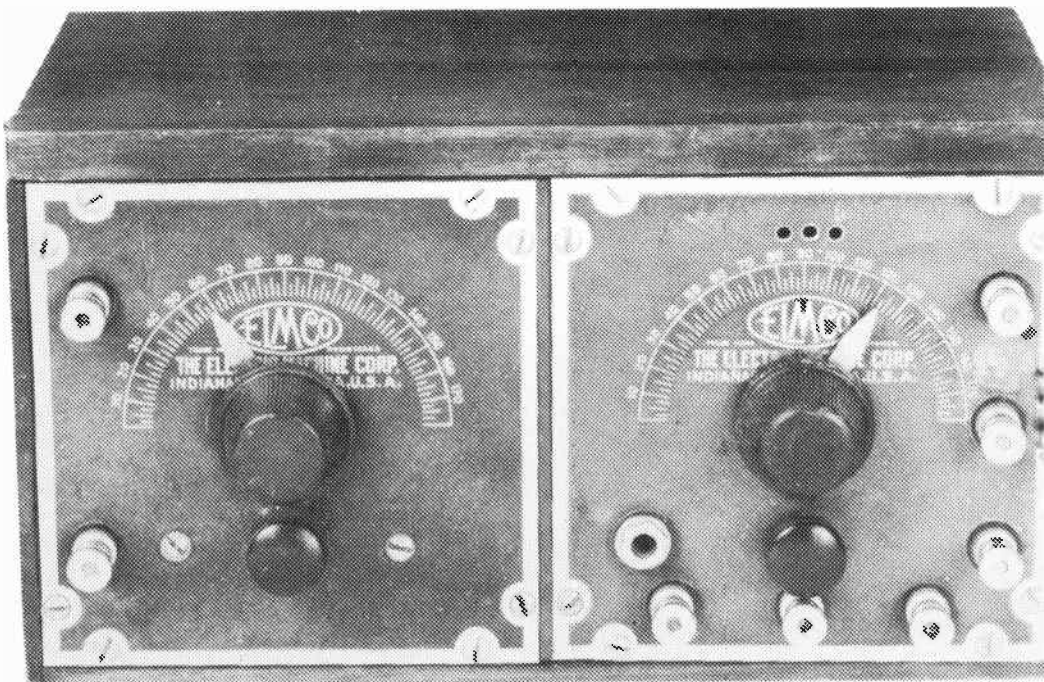



Remember this Classic Face?



This Cathedral Radio sparks Great memories of  
**MYSTERY THRILLERS!!**  
 -AND-  
**EXCITING EVENTS!**

... And the whole World was ours at the turn of a Knob...

This charm is captured in a beautiful rendering hand silk-screened on a 100% COTTON premium quality T-Shirts. Printed dark brown on Tan.  
 also available in Embroidery PATTERN or on Needlepoint Canvas  
 - WITH INSTRUCTIONS -

T-Shirts \$8.50 ea. + \$1.50 postage & handling  MED  LRG  X-L  
 MENS SIZES QTY QTY QTY  
 Needlepoint Canvas  \$20. + \$1.50 postage & handling  
 Embroidery PATTERN  \$8.50 + \$1.50 postage & handling   
 CALIFORNIA RESIDENTS ADD 6% STATE SALES TAX

Send to: *Lorraine Carole*  
 P.O. BOX 2661 VISUAL CONCERN  
 FORT MacARTHUR  
 SAN PEDRO, CALIFORNIA 90731

*Of Interest to our Members* 

Our President, Frank Heathcote, has proven again that "he who looks will be the one who finds". While coming home from the ARCA meet at South Charleston, W VA he stopped and bought a neon clock. When he got home he washed off the painted advertising and found that it was a PHILCO clock. How lucky can you get?

## RADIO COLLECTORS...

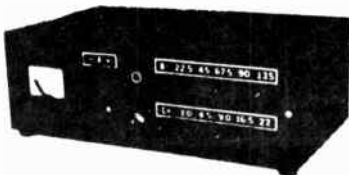

Gary Schneider has generously donated one of his solid-state power supplies to the IHRS. This well made battery eliminator has been tested on several receivers and lives up to it's excellent reputation.

Various A, B, and C voltages are available from the compact unit with plenty of power for up to 8 tubes. No hum was noticeable.

Gary has a kit of parts for radio collectors who want to build their own supply or he will furnish the unit completely assembled.

For more info send a SASE to:  
Gary B. Schneider, 9951 Sunrise Blvd.,  
#R-9, North Royalton, OH 44133.

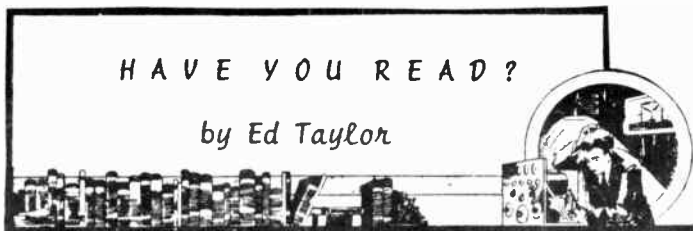

ANTIQUE RADIOS  
RESTORATION & PRICE GUIDE

by  
*David & Betty Johnson*

Should a lay person or antique dealer thumb through this book, they will be convinced that their 1940s console is an antique when in reality it is NOT. If a radio plugs in the wall it is not an antique even though it belonged to your grandmother. Most of the photographs are from 4 collections and seem to be of line operated sets of the 1930s, 1940s, and as late as the 1950s.

Technical restoration and radio theory aspects are a bit involved for the novice but the section on cabinet repairing and refinishing is excellent.

While most price guides are completely unrealistic, this one gives a better picture of old radio values. There are still several inconsistencies in pricing but this is most likely due to the narrow base of information on which the list was compiled.

Although this book contains some good information it could have been so much better if the authors had consulted a wider range of collectors and collections.

The book is primarily for recent radio enthusiasts who are just starting a collection of A.C. operated sets.

Available from: Wallace-Homestead Book Co., 1912 Grand Ave.  
Des Moines, IA 50305. Price: \$10.95 plus 75¢ postage.



# WLK

## Radio Broadcasting Station

2011 N. Alabama Street  
Indianapolis, Ind.

Radio Broadcasting Station W L K is situated on a small rise of ground in old Camp Morton, Indianapolis, Indiana. The antenna used is a six wire cage, flat top antenna one hundred twenty feet long and eighty feet in height. The antenna is directional east and west. The station is equipped with a sound proof room in which the broadcasting is done. W L K is owned and operated by Francis F. Hamilton, E. E.

The whole station equipment for broadcasting has been built by Mr. Hamilton in his experimental laboratory. The broadcasting first started in September, 1921, when there were only a few stations broadcasting entertainment. The call then used was 9ZJ. A ten watt set was used from September, 1921, until about April, 1922, when a one hundred watt set was completed. The demand for broadcasting in Indianapolis became very prominent about April, 1922, and Mr. Hamilton leased his station to L. S. Ayres and Co., a department store in Indianapolis.

The leasing of the station did not stop the experimental work and finally after much hard work at nights and Saturday afternoons a new five hundred watt set was completed and placed in operation October 12th, 1922. This set was built along entirely new lines in order to obtain the best possible modulation of antenna current with the least distortional effects. The new set uses four 250 watt tubes, two as oscillators and two as modulators. The antenna current normal at 360 meters is five amperes without any modulation. During modulation this current is increased considerably.

The generator voltage supplied to the transmitter is 3,500 volts normal for best modulation effects. The filaments are lighted from 230 volts A. C. stepped down by a stepdown transformer to the required voltage.

In reality W L K is a grown-up amateur station and is operated with the good old amateur spirit behind it. Early in the game W L K broadcasted only three nights a week because Mr. Hamilton felt that too much broadcasting was not good ethics and along this very line W L K has continued and made its wonderful career of entertaining the Hoosiers. Broadcasting must be of the highest type and not overdone. W L K has never paid for its programs as they are furnished free by Indianapolis artists.

In order to obtain artists without pay Mr. Hamilton, in conjunction with L. S. Ayres & Co., have formed a small three-cornered partnership with the Indianapolis News, who furnishes publicity for the local talent that appears on W L K's programs. The station is termed The News-Ayres-Hamilton Broadcasting Station.

To much cannot be said of Mrs. Hamilton, who has been the program manager, helping Mr. Hamilton in his work of broadcasting. Needless to say the success of the station has been due to the programs and this is where Mrs. Hamilton has shared in the sport of radio broadcasting.

The expense of the station is taken care of by Mr. Hamilton and the L. S. Ayres & Co. An operator is on duty most all day and every night to send out weather reports and daytime mechanical concerts.

Since the installation of so many broadcasting sets W L K has temporarily suspended broadcasting except on two nights a week in order to let the Indianapolis concert fans listen to other stations. This leaves only Sunday and Tuesday nights now for W L K to be in the air with musical and educational concerts.

Mr. Hamilton feels, as he has always felt, that the highest type of entertainment must be broadcast and it is with this in mind that a Tuesday evening educational course is conducted. Only the highest class music and talks should be sent out to the unseen audience.

Letters and cards are always appreciated and solicited by Mr. Hamilton, especially those asking for certain kinds of entertainment. W L K is tendering an unselfish service which it hopes to improve if conditions remain so that it can be done.

Weather reports are sent every morning except Sunday at 11:30 C. S. T. and again in the evening at 10:00 P. M. C. S. T., Sunday included.

### Transmitting Schedule.

Every day except Sunday—

11:00-11:30 A. M., music.

11:30, weather reports.

12:00-12:30 P. M., music.

2:00-2:30 P. M., music and market reports (except Saturday afternoon).

3:00-3:30 P. M., music.

5:00-5:30 P. M., code practice and athletic game results.

Sunday and Tuesday, 8:30-10:00 P. M.:

High class educational and musical concerts.

Wednesday afternoon: 2:30, crop reports.

HISTORIAN *Ed Taylor*

# Tech Tips

## PRESERVING THE ORIGINAL ELECTROLYTIC CAN

For those radios having part numbers as well as brand names stamped on top of the wet electrolytic filter capacitors which you wish to retain and at the same time replace the faulty capacitor, which is usually dry, here is the method I used. These were mounted above chassis (above ground), which permitted easy removal of the positive end with the aid of a 1" hole saw. Clean out the can thoroughly, use soap and water, removing any electrolyte or other plate material. You may need to ream out the hole to make it larger for the insertion of a dry electrolytic or to match the hole with the can's beveled edge.

Now it is ready to rebuild. Stuff some material (I used paper) down in the can to take up space and serve as a filler. If this was a single 8 mfd capacitor, insert a dry electrolytic 8 mfd (Mallory TC71C) inside the can with the positive lead pointing out the center of the opening and the negative lead bent 180 degrees to come out the same opening in close proximity to the edge of the can, but not touching. Stuff material around the new capacitor to keep it centered and in place about  $3/8$ " to  $1/2$ " from the surface. For a double 8 mfd can, place two dry electrolytics in the can by tying the negative leads together, lengthen the leads and above all, identify them as to which two are positive with one negative as they emerge from the opening.

For the final touch, heat some sealing wax in a small short can (cat food can works well) and pour into the opening, making sure your leads are where you want them and identified, fill until level with the top of the can. Just before the seal becomes too hard, etch your initials into the wax for that personal touch.



# The Two-Slide Tuner and the Bulb

**N**EXT to the single-slide tuner, the two-slide tuner is probably in greater use among owners of crystal sets than any other one piece of apparatus. The only reason that there are more single-slide tuners is probably because the single-slide coil is cheaper, but the difference in price should not figure in the choice because the double-slide tuner is undoubtedly much more selective on a crystal and is also much more selective and much more efficient when the crystal set is changed to a bulb set. With this article are shown the usual "schematic" diagram for connecting a two-slide tuner to a bulb, and also the same diagram converted into picture form for the benefit of those who do not understand how to read radio symbols.

This hook-up, like others which have gone before in this series, can be used with any of the tubes on the market. It is necessary only to use the proper A and B battery voltage to suit the tube and to be sure that the rheostat has the correct resistance recommended by the manufacturer.

All two-slide tuners are not exactly like the one shown in the illustration. But they all have two sliders with binding posts that connect to the sliders and most of them have some method or other for making a connection to each extreme end of the wire wound around the form. If yours does not happen to have these end connections, it is a perfectly easy matter to scrape off some of the insulation on the last wire on each end and solder the connection wire to it.

Here we have the aerial lead-in joining one extreme end of the coil—in this instance it is shown going to the end farther away from you as you look at the illustration. This same extreme end of the coil is wired over to the grid condenser and grid leak and that in turn is wired over to the grid connection of the socket. One of the sliders is then connected by means of its binding post to your ground wire which should run to your cold water spigot or a bright spot scraped on the radiator or to some other place where the electrical currents can easily find their way into the earth. It will not be difficult to establish a ground.

The other slider is connected by a wire running over to the positive filament connection on the tube socket.

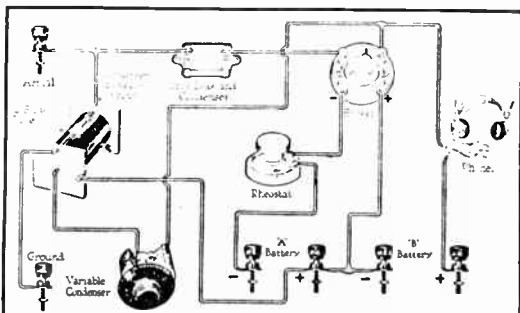

PICTURE FORM OF THE CONNECTION OF A TWO-SLIDE TUNER WITH A BULB

The other extreme end of the coil—the one shown nearest you in the illustration—is connected to one side of a variable condenser and this condenser may be either twenty-three plates or forty-three

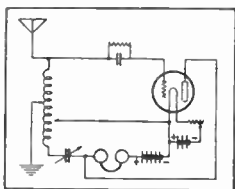

DIAGRAM OF HOOK-UP

plates, although the forty-three plate size is much better in this particular hook-up if you happen to have one. Do not forget, however, that it is not worth while buying a forty-three plate condenser for this particular purpose, because later on when you

change your set over to one of the modern hook-ups you will find that there are very few of these new circuits that use a variable condenser of that size.

The rest of the connections are very easy and can quite readily be followed by whichever one of the diagrams you use.

The tuning on this set is very simple and anyone can master it in a very short time.

Most of the main tuning will be done by the variable condenser. This will give a rough adjustment of the wave

length, although there may be some "mushing" of the signals when brought in by the variable condenser alone.

The next thing to adjust then is the slider which connects to the positive filament side of the socket. A point will soon be found where the signals will clear up nicely and that is where this slider should be left.

The other slider—the one which connects to the ground terminal—is used more for volume control and for tuning out interfering stations.

The fewer turns of wire there are between this ground slider and the aerial connection on the coil the more selective the tuning will be and the better will it eliminate interference, but it will also probably reduce the volume of the signals.

Still you must not expect to have both volume and selectivity in this particular hook-up, because you will not get these two very desirable features combined until we come to the somewhat more elaborate sets.

This hook-up will be found a very satisfactory one. It can easily be amplified later by inserting the primary of the amplifying transformer in the place shown here for the head phones and connecting

that transformer in the usual manner to the next tube. Later on will be given a diagram for an amplifying unit which will have two binding posts which merely connect up to the phone binding posts in this and other hook-ups which we are discussing now. In this way, it will be possible for readers to use their present outfits until they feel that they want to go into louder signals and then they can build the separate unit, connect the two units together and have goodioud speaker volume on broadcasting stations within a reasonable distance of their homes.

## Ask Our Radio Editor

**O**UR radio editor, Mr. Henry M. Neely, will answer at once and by mail all radio questions that COUNTRY GENTLEMAN readers may ask. In handling or having big sets and little ones, in remedying their troubles—he will help you out.

RADIO EDITOR  
THE COUNTRY GENTLEMAN  
PHILADELPHIA, PENNSYLVANIA

# Hit it anywhere!

## MAGNETITE RADIO-CRYSTAL

The most sensitive Crystal Detector on the world market. Unaffected by handling or moisture and will render efficient service indefinitely. Price 50 cents at ALL DEALERS—or mailed direct. GUARANTEED by

GIBBONS-DUSTIN RADIO MFG. CO.

OWNERS AND NATIONAL DISTRIBUTORS

518 WEST 9TH STREET

LOS ANGELES, CALIF., U. S. A.

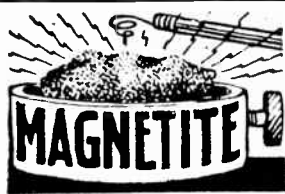

# ★ ★ RADIOADS ★ ★

WANTED: A set of four or five Pilot Wasp 5 prong Detector, plug-in coils with Loop-Top handles and 2 Pilot Audios. Ross Smith, 1133 Strong Ave., Elkhart, IN 46514.

WANTED: Pre-1945 National Radio Co. equipment, especially RBL, RAO, NC-100, and NC-10X receivers. Paul Greeg, 725 College Way, Carmel, IN 46032. Phone 317-846-3094 evenings.

WANTED: "Ship" cone speakers, Mickey Mouse radio, and Radio advertising. Have trades or will buy. A. R. Nolf, 620 Auburn Crescent, Burlington, Ontario, Can. L7L5B2.

WANTED: Old or unusual telegraph keys or bugs. Any early telegraph instruments and or test equipment. Also need coils for Grebe CR-18. Gil Schlehman, 335 Indianapolis, Downers Grove, IL 60515.

WANTED: WD-11 and brass base 01A tubes. George H. Fathauer, 1550 N. Bel Air, Mesa, AZ 85201. Phone 602-964-6920.

WANTED: Information, address, and phone number of Mr. Johnson, of Anderson IN, who had a display at the Indianapolis meeting on Feb. 26. Also wanted to contact the owner of a Crosley "4-29" W/X12 tube seen at the Auburn meet. C. E. Strand, Fairmount, IN 46928. Phone 317-948-3014.

WILL THE COLLECTOR that purchased four VT/24-864 tubes from me at Auburn and left without paying for them please contact me. James Fred, R 1, Box 41, Cutler, IN 46920.

RADIOADS  
(Continued)

FOR SALE: Replacement Dials for Philco radios. Four types fit models 33B, 84B, 93B, and 37-84. P. N. 27-5100 and 27-5031 are \$6.50 each pp. P. N. 27-5168 and 27-5210 are \$7.50 each pp. Peter F. Yanczer, 835 Bricken Pl., Warson Woods, MO 63122.

FROM THE MAIL BAG

I HAVE a Super Zenith model 28 radio, serial no. 227782. It is in excellent working condition and still has the original finish.

I am interested in selling this collectible to the highest bidder. If you are interested in this radio please write me at R 2, Box 98M, Gulf Breeze, FL 32561 Or call me at 904-932-9831, Michael McVoy.

TECH TIPS  
(Continued)

The innards are concealed and sealed for that professional look. Now you have the new electrolytic can-type capacitor retaining the original look, ready for reinstallation.

Submitted by Frank Campbell

ANOTHER "QUICK" TIP !

For gluing loose tube bases, use Dura Super Glue 3 (or equivalent). Make a fast ring of glue around the base and glass and pressure the two together immediately. Hold for 20 seconds for a permanent bond. Don't get your fingers in the glue or you will have a permanently attached tube that can only be removed by applying acetone.

Submitted by Ross Smith

# ARCA MEET 1983

Several members of IHRS enjoyed the eleventh annual Antique Radio Club of America Meet held at the South Charleston, W VA Ramada Inn on May 12, 13, and 14th. The West Virginia Chapter went all out to entertain us with true southern hospitality. Excellent two day tours of the area were arranged, which included two Glass Plants plus tours to the Pioneer Museum for all three days.

A three-day Flea Market, an auction on Friday afternoon and a very interesting twelve category "Old Radio" Contest brought out some very rare and most interesting old time radio equipment.

Saturday night's Banquet program included a most interesting interview with the pioneer radio announcer Hugh McPherson by Herb Morrison. The subject was the story of the first field recording of a news event, which turned out to be the dirigible Hindenburg disaster of 1937. The West Virginia Committee is to be commended for their most ambitious efforts, resulting in a most enjoyable Meet.

Ross Smith



# EARLY TV AT PURDUE "U"

The development of the cathode ray tube by Prof. Roscoe George of Purdue Univ. laid the ground work for the TV receiver of today. An extension of the cathode ray technology was the development of early TV at Purdue.

On December 31, 1931 the first TV program was broadcast from station W9XG located on a hill on the east side of the Purdue stadium.

Regular programming started on March 29, 1932. Your reporter was invited to see one of the broadcasts. It was a cartoon movie of Felix The Cat run through a regular movie projector and transmitted by means of a spinning disc. Although there were probably no more than five receiving sets in all of Indiana, reception was reported from Chicago and as far away as the state of Maine.

Purdue research engineers continued to make fundamental improvements under the sponsorship of RCA until World War II when the program was terminated. The station was listed in the Government Call Book as a visual broadcasting station. It was licensed to broadcast from 2750 to 2850 KC with a power input to the antenna of 1500 watts. The tower and its base building were removed when the stadium was expanded in the "60s".

Submitted by Marshall Howenstein





# IHRS SUMMER MEET

The next meeting of the Indiana Historical Radio Society will be held July 23, 1983 at the Riverside Park in Logansport IN.

Vans, pick up trucks, and car trunks will open for a session of buying and selling around 9:00 AM. There will be several contest categories with winners picked by popular vote. Categories are:

1. 2 tube sets, AC or DC
2. Celluloid radios
3. Foreign radios

At noon there will be a carry-in dinner with all sorts of goodies.

We need a Host for our Fall Meet. Come on! here is a chance for some IHRS member to make themselves a Hero. Provide us with a meeting place for our fall meeting.

EXTRA!

EXTRA!

EXTRA!

As a special treat for the children, Grandchildren, and yes for the members our President has arranged for the Carousel to be running during our meeting.

---

---

## MEET DR. TAYLOR

On May 2, 1983 IHRS Historian Ed Taylor was awarded his Doctor of Science in Electrical Engineering degree from the Sussex College of Technology in England.

The subject of Dr. Taylor's thesis was the mechanically scanned, solid-state television system he developed and which he demonstrated to IHRS members on February 28, 1981.

## *In Memory of — Someone Else*

We were saddened this month to learn of the death of one of the Society's most valuable members, Someone Else. The vacancy left by Someone's death will be difficult to fill. Else did more than a normal person's share of the work. Whenever leadership was mentioned, this person was looked to for guidance and results: "Let Someone Else work with that group."

Whenever there was committee work to be done, project to work on, or a meeting to attend, one name was at the top of everyone's list, "Let Someone Else do it." Someone Else was a wonderful person, but one person can only do so much and unfortunately everyone expected too much of Someone Else. Now Someone Else is gone! Who will do all the things Someone Else did? When you are asked to get involved in your Society do so. Remember, we can't depend on Someone Else any more.

Courtesy of  
ISA Signal Sources

