

Jan 1954

# **RADIO & TELEVISION DATA** *for* **RADIOTRICIANS\* & TELETRICIANS\***

(\*Registered U. S. Patent Office)

*Prepared as a Service*  
*Especially for Members of the*  
**NATIONAL RADIO INSTITUTE ALUMNI ASSOCIATION**  
*Washington 9, D. C.*

Compiled by John H. Battison,  
Director of Education, National Radio Institute

Reprinted from  
TELE-TECH and TELEVISION RETAILING  
Copyrighted 1953 (all rights reserved) by  
CALDWELL-CLEMENTS, INC.  
480 Lexington Ave.  
New York 17, N. Y.

# The Inside Story About

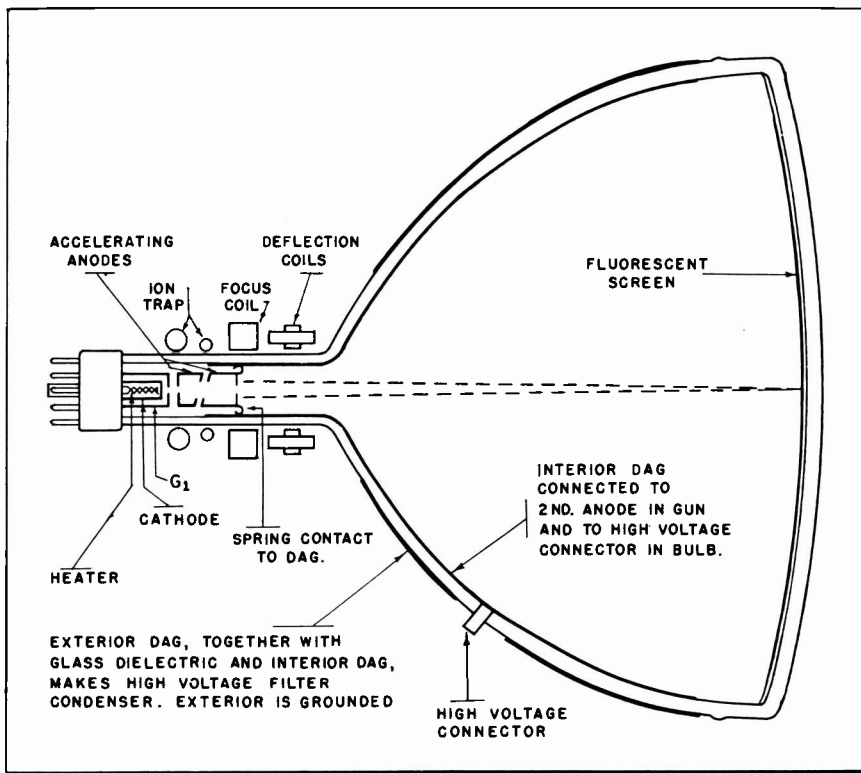

## Answering the Serviceman's Questions Concerning CRT's. How They Are Made, Renecked, Reworked, Reactivated, etc. Facts to Consider in Buy- ing and Selling Tubes for Replacement.

by Edward A. Campbell

● The business end of a TV set—and the largest and most expensive single component in it—is the picture tube. Dealers and set-owners alike have lavished a lot of concern on “the big tube,” since its failure could mean a large outlay of money—to the dealer if the set were under contract, and to the set-owner if the receiver were out of warranty and not under contract. For the first two or three years of TV, these fears seemed somewhat groundless, for the failures were more or less infrequent. During the recent two or three years, however, more and more tubes are reaching old age, and the number of failures has greatly increased.

In order to combat the HCL with respect to picture tubes, there has been a flurry of activity in the fields of re-building, reactivating, brightening, etc.

While attempting to weigh the pros and cons of these various techniques, and to learn to interpret the condition

of picture tubes as potential good or bad actors in the TV set, the retailer has been exposed to a welter of facts, half-truths, misconceptions, and in some cases, fictions.

The editors also hope to clear up some of the misconceptions, and to properly label opinions, theories and half-truths, to distinguish them from facts.

In order to properly cover the subject, we must first explain and define the processes which go into the making of the tubes.

In order to shorten this explanation, and at the same time show it in the clearest possible fashion, we have presented it in picture form on the next two pages. We have shown 20 stages in the making of high quality picture tubes, but actually there are many more steps—those shown are only among the most significant.

For instance, there are many steps to

the making of the gun which we didn't have room to show: the manufacture of the individual elements, the coating of the cathode, test of the cathode's emissive qualities, assembly of the gun parts on glass bead or styrene supports, the sealing of the gun to the glass stem and the testing of the metal-to-glass seal, clearing the gun of impurities, etc.

You will notice in the picture story a lot of large and expensive machinery and many painstaking quality control tests and inspections. Picture tubes are large and heavy products (especially now that most production is devoted to 21's) and the mass production of uniform high quality tubes cannot be performed with a shoe-string operation.

### Quality Controls Important

Tubes can be—and once were—made by hand. But mechanization under careful control insures that one tube will be just like the next one, and that pre-set standards of quality and long life will be met.

Each test and inspection is important, and many tubes are rejected because they do not come up to snuff. For instance, in the initial bulb inspection, there is a maximum permissible amount of bubbles and blisters in the faceplate—and the industry has established higher standards now than we had three years ago when tubes were smaller. Screen inspection is vital because a non-uniformity of coating thickness or of baking will produce bands or areas of lighter or darker color which will be very objectionable when in use. Air conditioning in the plant is important to keep impurities out of the bulb after it has been washed—and absolutely pure, distilled, de-ionized water is important in the washing for the same reason. Careful control of baking and cooling temperatures is necessary, not only to prevent bulbs from breaking in the oven, but also to prevent the development of stresses in the glass which would cause breakage during the exhaust process. Proper activation of the cathode and adequate aging are necessary in order to insure adequate emission and long life under actual use. There are some tubes which have been successfully reactivated which were successful because they weren't properly activated in the first place. Such tubes would go soft early in their lives.

But so much for the manufacturing processes—suffice it to say that there are no shortcuts to the making of good picture tubes.

Picture tube manufacture starts with the glass or glass-metal blank or bottle—and thereby hangs a tale. The contention of the rebuilders is that there is nothing old in a rebuilt except the bottle, and glass lasts a long time.

# Television Picture Tubes



← **1** Picture tube manufacture starts with the empty bulb, envelope or "blank." Glass blanks are supplied to the tube maker by glass companies such as Corning and Kimble. First of many quality control tests and inspections is examination of the blank under a strong light for bubbles or other imperfections.—RCA



In another part of the plant, assembly of **2** → the gun is performed—guns and bulbs will come together later in the process. Here complete guns (foreground) are being mounted on glass stems (to the right of the operator) containing leads for each tube element.—Haydu

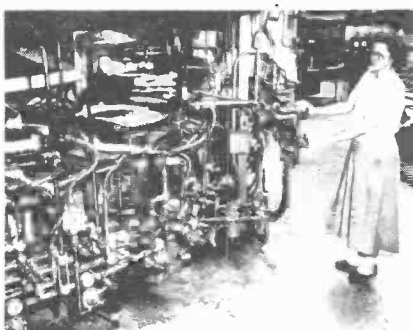

← **3** Metal cone tubes are usually assembled in the tube plant (as opposed to glass, which are received complete from the glass manufacturer). Here the glass faceplate is being fused onto the metal cone. The glass neck has been similarly fired onto the other end of the cone.—RCA

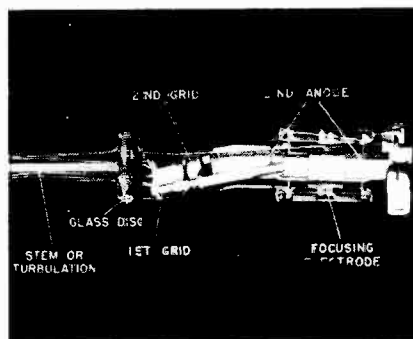

Close-ups of the gun after mounting on the **4** → stem. The glass disc through which the leads go to the gun will later be sealed (by heat) into the neck of the tube. The tubulation at the left will then be used to exhaust the tube. This is an electrostatic focus "bent gun."—DuMont

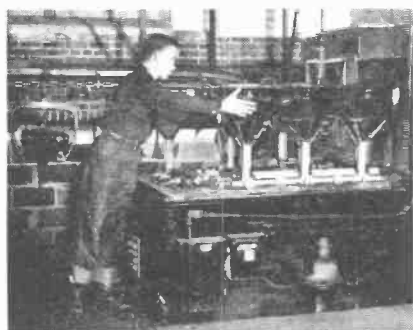

← **5** After inspection, bulbs are carefully washed with distilled, de-ionized water and strong chemical solutions. Here automatic conveyor takes bulbs into machine at right, where solutions will be sprayed up inside. After washing, the bulb is thoroughly dried.—National Union



Purity, uniformity and precise control are **6** → important in the preparation of the phosphors which will make the screen inside the tube face. Here stainless steel vats and pipes with welded joints are used in an immaculate solution room. Small firms buy ready-mixed "slurry."—Sylvania

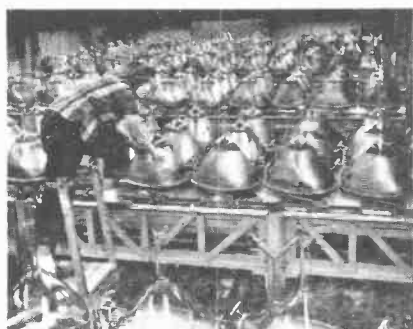

← **7** To make screen, phosphors are poured in bulb onto a "cushion" of pure water and allowed to settle. A binder in the solution makes it adhere. Bulbs are shown moving slowly along on huge settling conveyor in vibration-free, temperature and humidity controlled room.—RCA

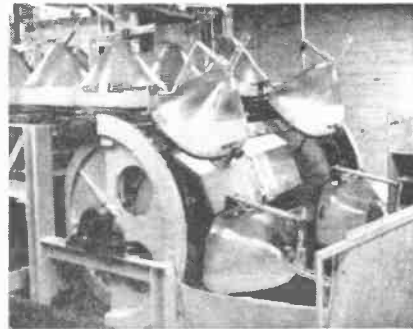

At the end of the settling conveyor, bulbs **8** → are very slowly decanted so as not to disturb screen which has been deposited. Cloudy water is washed out of neck, and then tube is dried with gentle warm air stream.—DuMont



← **9** Next screens are inspected for uniform coating and for flaws under ultra-violet light which makes them fluoresce. Here screens are dried on way to inspector by a tube inside neck which blows warm air while bulbs move along on dollies.—Sylvania

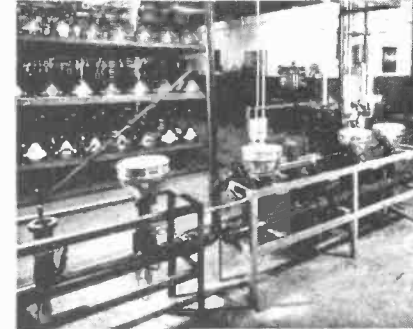

Aluminized tubes require special handling. **10** → After normal screen settling and drying, hot aluminum is evaporated onto back of screen and inside funnel while tube is evacuated. Bulb is then opened and goes through steps 14-18 (next page) like any other tube.—Rauland

# The Inside Story About

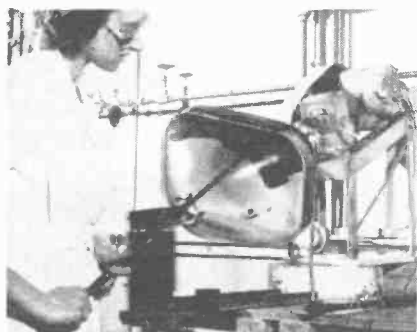

← **11** All metal and glass bulbs (except aluminized) are given an interior conductive coating of aquadag. Some firms float this graphite solution up into tube, most paint it by hand while tube is spinning, as in this photo. Dag contacts 2nd anode button.—General Electric

In this long, gas-fired oven, bulbs are **12** → heated to bake the screen and aquadag and bake out impurities. In the long tunnel, bulbs are gradually brought up to a high temperature and then gradually cooled so they can be handled when they come out.—National Union



← **13** This is the entrance to a different type of oven (strips in background are to hold heat in). Process is the same as step 12, except that the oven is larger, allowing several tubes abreast to go in all at once.—RCA

Baked tubes are given another screen in- **14** → spection and then go to the rotary machine in the background, where guns are sealed in. Gun is mounted on a jig, bulb neck is slipped over it, then gas jets seal the disc shown in step 4 to the neck of the bulb. Finished bulbs in foreground are ready for connection to the exhaust pump.—Thomas Electronics

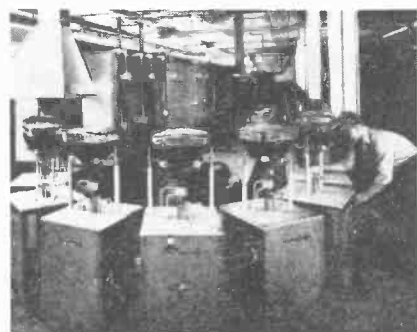
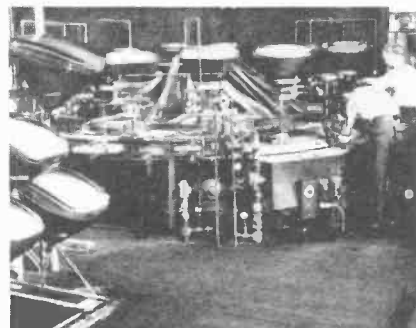

← **15** Individual exhaust dollies take bulbs into another oven where tubes are evacuated while heat drives gasses out of glass and gun. Filament voltage is applied to activate cathode, and RF heater (around neck) explodes a capsule of "getter" material which will further absorb gasses during life of tube.—Hytron

Coming out of exhaust oven, glass stem or **16** → tubulation is simultaneously sealed up and snipped off, removing the tube from the exhaust pump. This is known as "tip off." Bulb is actually a vacuum tube now, complete except for base.—National Union

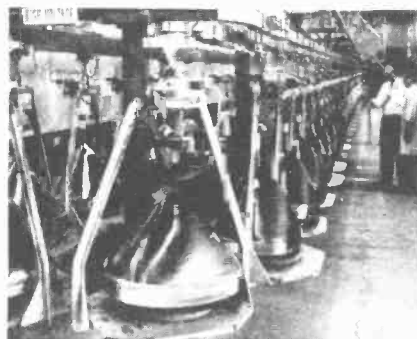
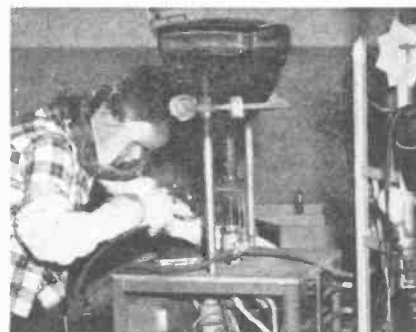

← **17** Next, tube base is soldered and cemented on, and then tube goes on these aging conveyors, where "accelerated" (higher than normal) voltages are applied to all elements to "set" cathode emission and age tube. A high voltage spark is applied to clear gun of impurities.—Sylvania

Tube is given an actual operating test, **18** → covering spot focus and centering, brightness, color and operation with a real video signal. Shown here is the giant, metal-cone, 90-degree deflection 30-inch tube.—DuMont

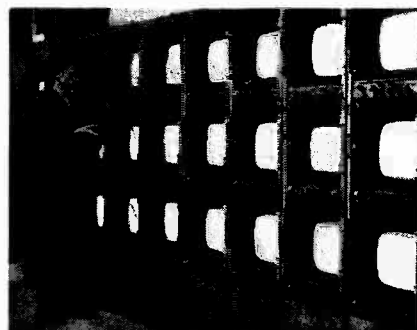
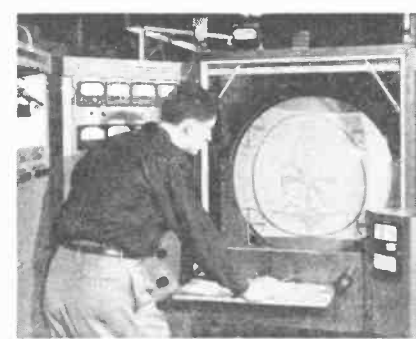

← **19** In most plants a certain percentage of tubes are withdrawn from production for various types of "life test." Some are on "accelerated" life (higher voltages), some are switched on and off periodically to simulate actual use, some have just a raster, some a pattern.—General Electric

After step 18, tubes in normal production **20** → are put into storage for a while and then given another final test. The exteriors have been sprayed with dag, the type number stamped on, the faces polished, and then they are boxed. Here they are getting the final test before packaging.—General Electric



# Television Picture Tubes

Before going into further details, we must define the term "rebuilt." We have investigated the field, and find (not to our surprise) that there is no hard and fast definition of that word.

We do find the word's meaning pretty well established by other uses, however. For instance, we have rebuilt vacuum cleaners, rebuilt typewriters, rebuilt carburetors and even rebuilt TV sets. But did you ever hear of a rebuilt bottle of "coke"? In other words, "rebuilt" usually conveys the idea of "re-conditioned." If the contention we mentioned above were correct—namely, that there is nothing old in a "rebuilt" except the bottle—then the term "rebuilt" would obviously be a misnomer, just as it couldn't apply to "coke" in a re-used bottle. There are certain instances, however, where "rebuilt" could apply, as we will show later.

Here are some of the processes we have found in practice and how we would classify them: (1) In making glass blanks at the glass factory, some necks get broken, and the glass company puts new necks on before shipping the blanks to the tube maker. (2) In the making of tubes, some necks get broken, and new neck sections must be brazed on (at the tube factory); (3) In the making of tubes, some are rejected for one reason or other and are washed out and made over; (4) Some manufacturers of new tubes allow a trade-in allowance on "duds." The glass from the duds is re-used in the making of new tubes; (5) Some firms only make tubes from re-used bulbs, for the replacement market. These tubes are made the same way as are new ones, from the washed bottle onward, except that in some cases the firm does not have the full complement of equipment or trained personnel as do the larger tube makers. In a few cases, we have seen some tubes of this category sent out with the name of the original manufacturer still on them; (6) There are some firms who open the neck of a dud, repair the gun, and re-exhaust without washing and re-screening; (7) There are some firms who re-activate or spark bad tubes.

We would classify these types as follows: Types 1 & 2: re-necked; types 3, 4 and 5: re-worked tubes; type 6: rebuilt tubes, and type 7, reactivated. Thus, we apply the term "rebuilt" only to tubes which have been re-conditioned, and not to tubes in which everything inside is new. As a matter of fact, many tube makers do not even go along with a word like "re-worked" (where everything inside is new) or any word with "re-" in it, since that implies that there is something inferior about the tube, when actually all their tubes must meet the same standards.

Why have we classified 3, 4 and 5 all the same way? Are they of equal merit? In some ways, yes, and in some

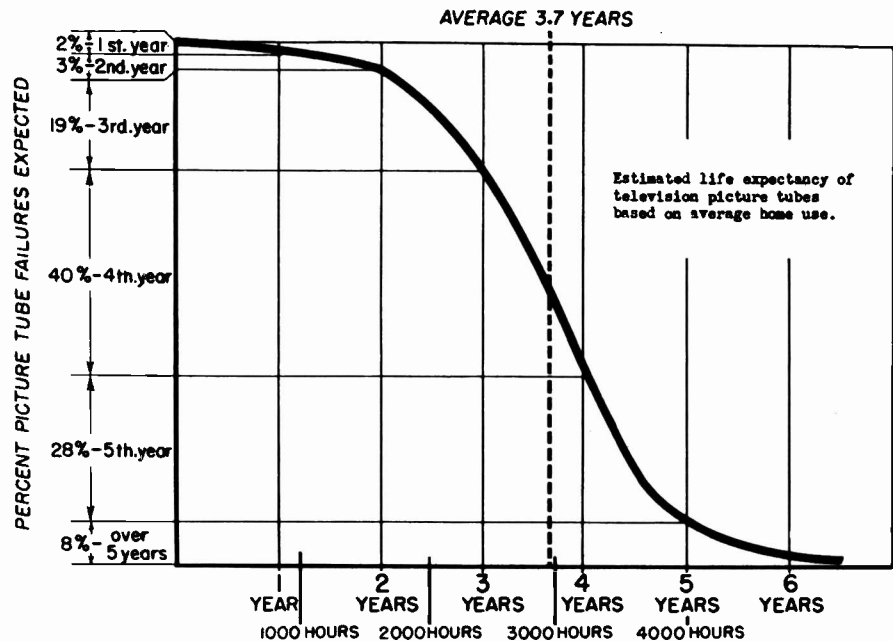

ways no. We find that most of the larger manufacturers, under certain conditions, do not distinguish between new and re-used glass. These conditions are that the re-used glass must have no deep scratches on the face, no scratches or bruises at all on the part of the funnel nearest the face, must conform to current industry specs on bubbles and blisters, must have no raster burns—must, in other words, be just as good as new glass.

Glass does not fatigue or weaken with age. It is, however, highly sensitive to scratches and bruises. The main trouble with a dud is that it is liable to have been mistreated, whereas a new tube is not. The only way you can be sure about the glass in the tube is to buy a brand which has a long reputation for quality, high standards and lots of know-how.

What about raster burns? Not all tubes get burns or discoloration on the face—but they can, especially if they have been in use a couple of years or more, and are 16-inch or larger tubes which operate at high 2nd anode voltages. A manufacturer with high standards would simply reject a bulb which had a raster burn.

How about a type 5 re-worked tube (from the firm which only makes replacement tubes with re-used blanks)? Does it have the same quality gun and screen as a good new tube? Was it as carefully screened, baked, sealed, exhausted, aged, tested? You'll have to depend on your knowledge of the manufacturer and his reputation in order to answer those questions. If you want to take a chance, it's your money. Or is it your customer's?

How can you tell whether a tube was re-worked without removing the name of the original manufacturer? Very

easily. If you only buy the original manufacturer's tubes from an authorized distributor of those tubes, you can be sure that he knows where he got them from.

Is it true that a re-worked tube has an *advantage* over a new one because the gasses normally given off in the life of the tube have been used up? No. Many gasses come from the gun, and a new gun would start the process all over again. In addition, old glass will start giving up gasses again if a tube is opened up and then re-evacuated.

Must a tube get a new screen once it's been opened? If the tube is opened suddenly, the inrush of air will blow the screen off, or at least parts of it. It is possible to control the inrush of air very carefully in order not to blow off the screen. But then you get dust, dirt and impurities in the bulb which cannot be washed out without washing off the screen. Most big manufacturers would consider this more trouble than its worth, even if there were no hazards.

Can tubes be reactivated? There are no statistics on this subject, but most authorities consulted seem to feel that at best this works in less than 1/3 of the cases, where the trouble is low emission. And even then, experience seems to show that the "success" is short-lived. If a tube's emission is so low that a satisfactory picture cannot be obtained, the tube is "over the hill," so to speak, and most expedients merely put off the inevitable. Naturally, expedients of this type wouldn't help if the filament were open (or any other element, for that matter) or if there were a dead short in the gun.

To sum up the case for and against rebuilt tubes, we believe that if we were

(Continued on following page)

# Improved Tri-Color TV Picture Tube

Chromatic Television Labs. has recently demonstrated an improved tri-color TV picture tube—the Chromatron—also known as the Lawrence tube. The tube's good resolution and excellent color fidelity proved to be comparable to, or better than, other types demonstrated to date. Unfortunately, facilities available for the demonstration limited the showing to standard color slides, which were made by Eastman Kodak for NTSC.

The single-gun, 22-in. tube, shown in Figs. 1 and 2, has a rectangular color face, 18.5 in. diagonally. Developmental work is also proceeding on a three-gun tube. In either case, dimensions, deflection components and deflection angle requirements of 70° to 90° are all similar to standard black-and-white tubes. Chromatic claims that the Chromatron utilizes 85% of the total electrons available, as compared to 14% possible with mask type units.

Cost for mass-produced tubes is expected to run about twice the amount for equivalent black-and-white types. On an individual sample basis, the metal-coned Chromatrons are presently being sold to laboratories for \$500 each.

The recent demonstration of the single-gun tube employed the CBS color system, but it is not limited to any one system. It is possible to obtain very bright pictures with single-gun time-

Fig. 1: Front view shows 18.5-in. color face

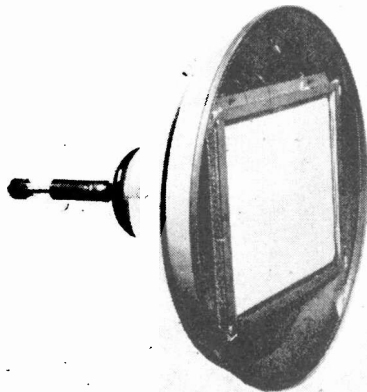

shared operation. Information received at press time indicates that further progress has been made in displaying NTSC signals on the single-gun tube using 3.6 mc switching and keying circuits for the color modulation. This advance is expected to be shown to the industry around the middle of Feb. 1953.

The tube of Fig. 1 contains 1000 vertical color phosphor strips with 500 grid wires. Still better performance should result from one developmental type which utilizes 1600 vertical strips, each 10 mils wide, and 20-mil wire spacing. One result of these narrow strips is a 300-line resolution.

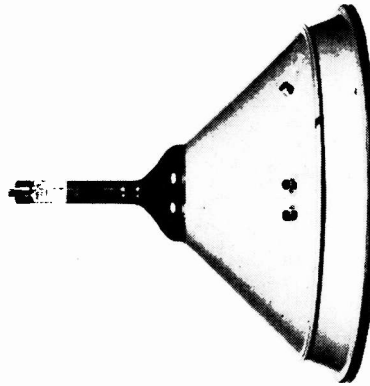

Fig. 2: Chromatron is built with metal cone

To review the operation of the Chromatron briefly, Fig. 3 shows how the electron beams in a three-gun tube pass through the color control grid and strike their respective red, green and blue phosphors. In the single-gun tube, Fig. 4, one electron beam passes through the double grid to strike the green phosphor strip. As the beam scans across one line, the potential on the grid wires is varied at proper time intervals in such a way that the electron beam is deflected slightly to impinge upon the red or blue strips, as desired.

It is of interest to note that the main horizontal deflection system (not shown) can cause the beam to scan

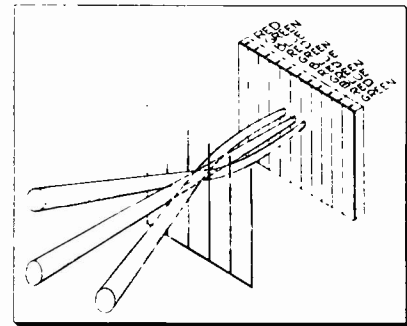
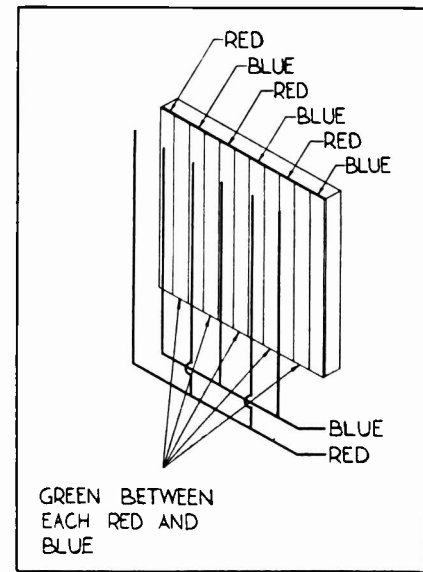

Fig. 3: Three-gun electron beams through grid

across the wires and phosphor strips at any angle to the wires, and still produce an excellent picture. The only thing that changes as the scan is changed from perpendicular through parallel to the wires, is that the basic picture element structure changes from line- to diamond- to checkerboard-shape. Since preferred element shape is in large measure a subjective reaction, more extensive personal reaction tests are planned.

Fig. 4: Grid structure for single-gun tube



## TV Picture Tubes

(Continued from preceding page)

asked, "Which is better, a new or a rebuilt tube?" we would have to ask: What do you mean by "rebuilt"? Who made it? How did they do it? And so forth. Since in most cases the purchaser is unable to find answers for all these questions, he is faced with the alternatives of taking a chance on something he doesn't know, or sticking with something which has always been reliable.

We have dwelled at length in this article on the processes which go into tube manufacture and the necessity for them in order to get across the point that this is not something to "take a

chance on." If a reliable tube manufacturer offers a tube with a weld mark on the neck, it is not a rebuilt, and not necessarily a re-worked tube. On the other hand, if such a manufacturer reuses glass in making tubes, it is not incontrovertible evidence that all re-worked tubes are reliable. It is not even true that all tubes which are sold as rebuilt are actually re-worked from the bare glass up, as we pointed out above. From this point, the decision is up to the reader, but we believe that the answer should be fairly obvious.

## SHOP HINT

### Soldering Iron Stand

An extra soldering iron stand that takes up very little space can be made

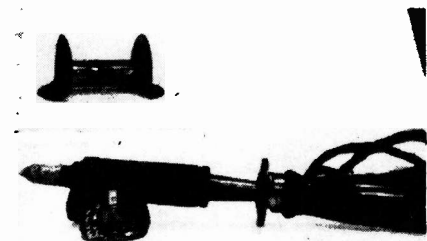

out of an empty solder spool by bending the ears flat, as shown. Harvey Miller, Box 6, Danboro, Penna.

# Sound, No Raster

## Fast Troubleshooting Procedure for Home Repair of Sets with Above Symptom

By Peter Orne

• This article is primarily concerned with the servicing of the television receiver in the customer's home when the symptom is *good sound, no raster*. In the preliminary check, all controls that the customer might have misadjusted should be turned through their range and effects noted. Special attention should be given to rarely-used switches that may accidentally have been turned. This applies particularly to the FM-TV switch on DuMont sets and the back panel phono-TV switch on many Philco and some RCA Victor models.

Care should be taken with the brightness and the drive controls if no raster is visible. These controls should be first turned through their entire range, then left in about the center of their range. In the case of the brightness control, mid-setting it is a precaution to prevent damage to the CRT if the ion magnet should be incorrectly positioned. It takes only a minute or so of operation with full brightness and incorrectly-set magnet to make the CRT gassy, or to burn a hole in the gun structure. In the case of the drive control, excessive drive may damage the horizontal output tube, the output transformer, or other components in this circuit.

It is important not to attempt readjustment of the ion magnet any sooner than is absolutely necessary. If the ion magnet has been reset and the trouble turns out to be elsewhere, the magnet may be out of position long enough to permit damage to the CRT before the serviceman remembers to readjust it.

### Misadjusted Ion Magnet

Some symptoms definitely indicate a misadjusted ion magnet. In Rauland tubes, and in some rebuilt tubes, the aperture plate in the first anode is coated with a green phosphor to facilitate the ion magnet adjustment. If the phosphor glows when the brightness control is turned up, it indicates that the electron beam is hitting the first anode instead of passing through the aperture to the screen. In other CRT's the presence of

a bright bluish glow at one or two points on the neck of the tube indicates that the electron beam is hitting the neck, due to ion magnet misadjustment. In these two cases, immediate resetting of the ion magnet is indicated. In other cases, resetting should be deferred while likelier sources of trouble are checked.

The first logical test procedure is the inspection of the CRT filament. If the filament of the CRT is not lit, the trouble can only be a bad CRT or defective

CRT replacement is therefore advisable if the supply voltages have been found normal. As far as the filament supply is concerned, the vast majority of sets use a filament winding on the power transformer. In most sets there is one filament winding for all the tubes except the rectifiers. If this winding is defective, the many unlit tube filaments present will point to the trouble. If the CRT is the only tube not lit, the trouble can lie in its socket or socket wiring.

### CRT Unlit Due to Short

There are a number of sets where there is a separate winding for the CRT and damper tube, because their cathodes are at B+ potential and the cathode-to-filament potential must be kept low. In these sets, the filaments of the damper and CRT are returned to B+. A short in the damper circuit, or a shorted tube, may be responsible for the CRT not lighting. In some Emerson models the power amplifier is connected to the separate filament line referred to, since its cathode is at B+ potential in these sets. This special filament winding is apt to give trouble, since the transformer insulation may not be adequate. Incidentally, if such a separate winding is defective, it is generally more economical to install a small filament transformer than to replace the power transformer. The filament transformer should, if not internally well insulated, be mounted in such a way that it is insulated from chassis.

There are a number of sets with a transformerless power supply, in which the filaments are in series-parallel. Trouble in the filament circuit, such as bad ballast tubes or resistors, shorted filament bypass condensers, open filament chokes, tubes with open filaments or internal shorts, can cause the CRT to light dimly or not at all.

If the CRT filament lighting is normal, the next logical check is for high voltage at the CRT connector. The best way to make such a check is, of course, by using a high-voltage probe. The second best method lies in the use of a  
(Continued on following page)

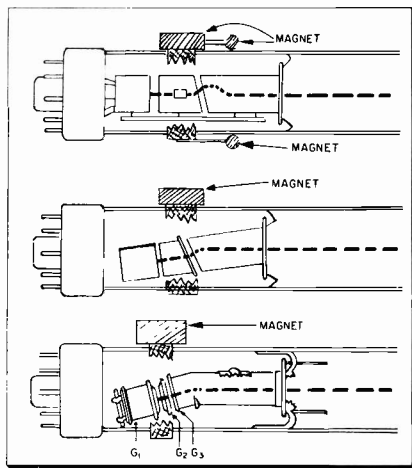

Fig. 1 A) Straight gun. The axis of the gun is the same as that of the tube neck. B) Tilt gun. The gun's axis is tilted approximately 3 degrees from the axis of the CRT neck. C) Bent gun. The 1st anode (G<sub>1</sub>) has a bend of app. 5°. Tubes employing tilted and bent guns use a single ion magnet; a double ion magnet is employed in CRT's with straight guns. (Courtesy, Capehart)

filament supply. The normal procedure with any bad tube would be to replace it, but since a good deal of mechanical labor is involved in the case of a CRT replacement, it is preferable to make certain first that the tube is really bad.

Measuring the CRT filament resistance (after removing the CRT socket) is the next logical step. If the filament resistance reads normal, the power supply becomes suspect. Note, however, that it is possible for the filament to read normal on the meter when cold and open-circuit when power is applied.

## SHOP HINTS

### Prolonging "Mike" Life

Moisture often gets inside crystal microphones (even though they are sealed against it) damaging the crystal element, with resultant loss of sensitivity and frequency response. When this happens, place the "mike" for twenty-four hours in a clean, dry airtight can containing one pound of fresh silica gel, and it will behave like new, with the beneficial effects lasting a long time. Harry J. Miller, 607 Wynnewood Road, Phila. 31, Pa.

### Safety Trick

Whenever a hole is drilled in an appliance or its containing cabinet, the possibility is always present that the drill chuck may dent or otherwise mar the surface when the drill breaks through. To insure against this hazard, slide a rubber grommet over the bit and up to the chuck, to act as a buffer and cushion the blow. Edward Mayover, 1501 N. 61st Street, Phila. 31, Pa.

### Preventing Capacitor Damage

Considerable damage to condensers may be caused by the heat of a soldering iron, especially where short leads are to be soldered. To reduce the amount of heat that reaches the condenser, grip the bare wire between it and the iron with a pair of pliers. This will divert most of the heat into the jaws of the pliers, but will not prevent or delay soldering, nor will the heat injure the condenser. Harry J. Miller, 607 Wynnewood Road, Philadelphia 31, Pa.

# Trouble-Shooting Methods

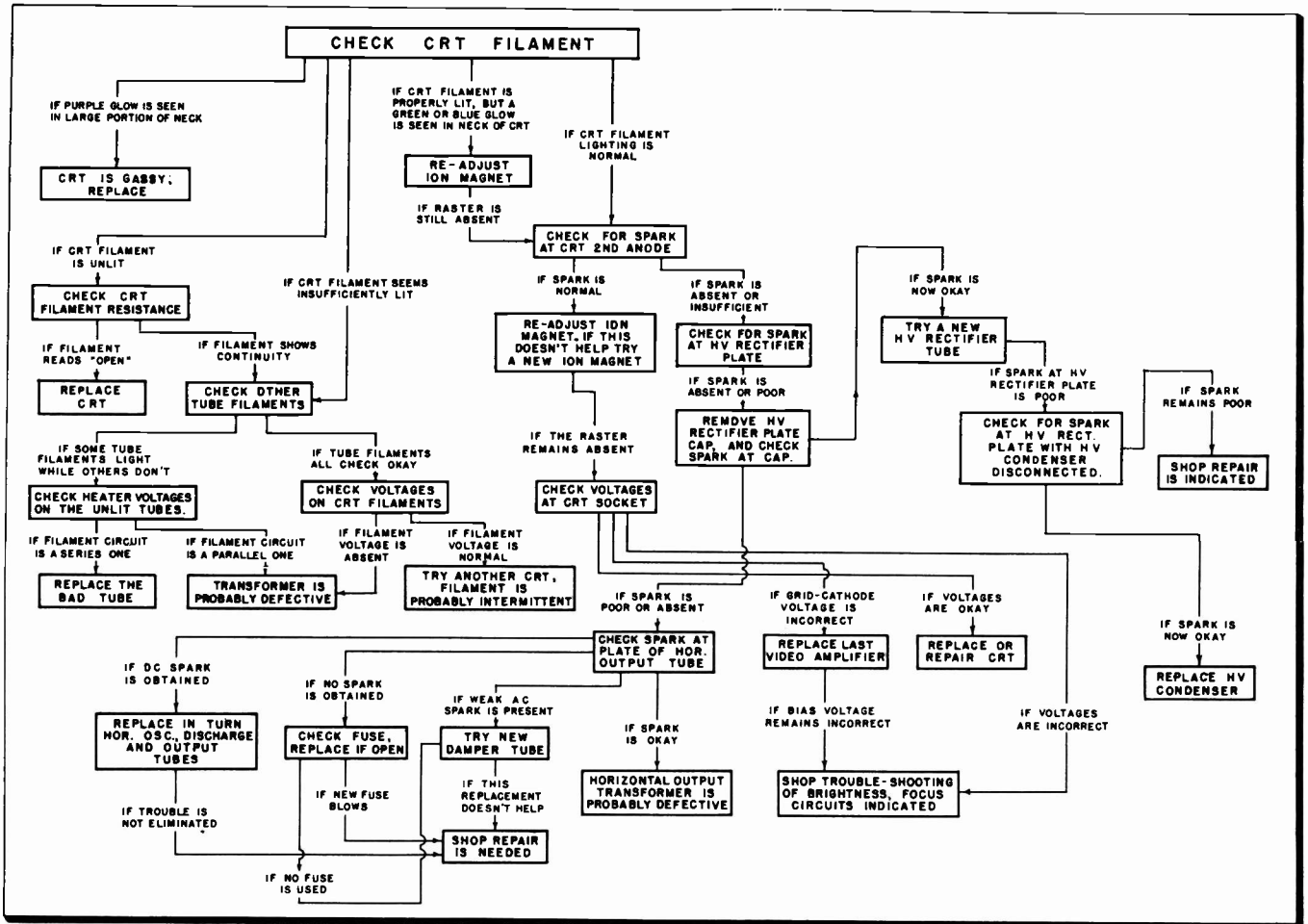

Chart of suggested troubleshooting procedures when symptom is good sound, no raster.

(Continued from preceding page)

calibrated spark-tester which is commercially available or can be constructed in the shop. Lacking either of these service instruments, a spark drawn between the high-voltage lead and the CRT connector can be judged for voltage by its length. With some practice this can be done with fair accuracy. The high-voltage lead should never be sparked to chassis. If the set contains a high-voltage circuit fuse, the latter will blow; in a set without a fuse, damage to the rectifier or transformer or other component in the high voltage circuit can result from such a practice.

It is important to remember that if the CRT is not drawing current for any reason, it will hold a charge, and no spark can be drawn to the high-voltage lead. The procedure in checking by the spark method is therefore as follows: With the set off, the high-voltage lead is disconnected from the CRT, the set turned on, and the lead brought near the CRT connector. If no spark or only a small one is obtained, the CRT is discharged to ground with a piece of wire.

The wire should be connected to ground first to prevent getting a shock. The high-voltage lead is then sparked to the CRT again. If a normal spark is now obtained, the trouble lies in either the ion magnet setting, the supply voltages at the CRT socket, or the cathode-ray tube itself. The ion magnet can now be readjusted, with the brightness control turned three-quarters up. If rotating and moving the ion magnet back and forth does not produce the raster, the adjustment can be tried rapidly with the brightness setting at maximum. If no raster is obtained even now, the brightness is turned down immediately, to the center position of the pot. The brightness must not be left fully up for more than one minute, without a raster.

If ion magnet readjustment doesn't help, a known good magnet should be substituted, especially on sets that are old and have lost their brightness gradually. The correct ion magnet for the tube can be determined by checking the shape of the CRT's electron gun (See fig. 1). A bent gun and an angled gun require a single ion magnet. Straight guns with the elements cut at an angle use double ion magnets. When the lat-

ter type unit is employed, the larger magnet is placed nearer to the CRT socket.

If adjustment or replacement of the ion magnet fails to fix the receiver, the voltages at the CRT socket should be checked. Since the base connections on magnetically-focused and deflected tubes are standard, it pays to memorize them (fig. 2). Electrostatic focus and self-focus tubes do not add too many complications; their base connections can be remembered readily too. Electrostatically-deflected tubes have high voltages at their sockets that cannot be measured with ordinary voltmeters. Since leaky condensers in the high voltage section are the most usual fault, and the sets are small and light, the best procedure is to take them to the shop for servicing.

In magnetically-deflected sets the CRT socket is removed and the voltages are checked with respect to cathode. The bias should vary with the setting of the brightness control, usually from -80V at cut-off to almost zero volts at full brightness. If little or no variation is found, the set usually needs major repair and should be taken to the shop. An exception to this statement is found



# for Sound, No Raster

in the case of receivers using a direct-coupled video amplifier circuit. A bad video amplifier tube in such sets can cause incorrect bias voltage at the CRT. It is therefore a good idea to change the last video amplifier tube and check the voltages again, when the CRT bias is found to be wrong. If the first anode or electrostatic focus voltage is incorrect, the trouble is usually a shorted condenser or possibly a bad focus pot, and shop repair is indicated. If the CRT voltages are correct and vary normally, the CRT is defective (see fig. 3).

The reason that the CRT voltages are checked with the CRT disconnected is that an internally-shortened CRT will cause incorrect readings. The CRT may be checked for short or leakage in these cases with one of the new test-and-re-activation devices. On some of these, a high voltage is available for burning off the short, thus repairing the tube. (Such a procedure has its pros and cons . . . we do not necessarily endorse it. —Ed.) If no such instrument is available, CRT replacement becomes necessary.

Keep in mind that, with the tube disconnected, the voltages are measured when the CRT is not under normal load. The possibility that circuit trouble may be present even when CRT socket voltages read okay should not be overlooked. For example, the focus voltage may read normal yet there might be a resistor in the circuit which has increased in value, causing the voltage to go very low when the CRT is connected.

Going back—if the spark at the CRT is low or completely absent, remove the high-voltage cage and check the spark at the HV rectifier cap. This is an AC spark and can not be measured satisfactorily with a meter even when a high-voltage probe is available. Special

spark, once made, can be pulled out to more than twice its original length, unlike a DC spark which makes and breaks at about the same point.

The spark voltage can also be judged by drawing the arc to a screwdriver with an insulated handle. The same tool should always be used since the length of the spark varies radically with a change in the material of the handle. The spark should never be drawn to chassis for the reason mentioned previously (possibility of either burning out the fuse, or damaging tubes or components, mainly the horizontal output transformer).

If a normal spark can be obtained at the HV rectifier cap, but not at the CRT anode, the trouble is in the rectifier tube or circuit. The HV rectifier should be replaced first, which may repair the set. If it doesn't, the trouble may be a short or leakage in the HV filter condenser, an open or increase in value in the HV filter resistor, or a defective high-voltage lead.

It is a simple matter to check the high-voltage condenser (when one is present). If the set will operate with the condenser disconnected, the condenser should be replaced. (The condenser should not be left off permanently—the HV regulation will be impaired and the brightness decreased, if it is omitted). If there is no high voltage at the CRT with the condenser removed, shop repair is advisable, due to the difficulty of reaching the high-voltage rectifier socket.

If insufficient or no spark is obtained at the rectifier, the cap should be removed from the tube and the spark tried again to the lead. The reason for this is that a short in the cathode circuit of the rectifier may provide sufficient loading to prevent the normal spark at the

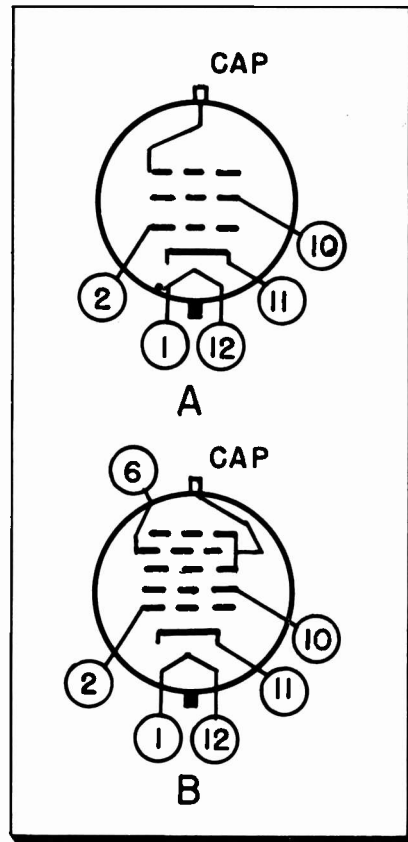

Fig. 2 A) Standard basing diagram for magnetically-deflected cathode-ray tubes that are magnetically-focused, self-focused or automatically-focused. B) Standard basing diagram for magnetically-deflected and electrostatically-focused cathode-ray tubes.

ond tube's cap is removed. Half the normal voltage will then appear at the CRT connector. The defect is hard to find when the resistor reads normal on the ohm meter but breaks down under voltage. The unit is usually a carbon film resistor, two megohms with 10,000-volt breakdown rating. It can be replaced with the original part or with four 500,000 ohm resistors connected in series. The solder joints of the series resistors should be made round and smooth to prevent corona discharge.

In the vast majority of receivers the kickback power supply is used. In these sets, we must check the horizontal sweep section if no spark is obtained at the rectifier cap. The most popular output tubes, the 6BQ6, the 6BG6, and the 6CD6, have plate caps and the spark test can be used again. The spark should be about one third the length expected at the rectifier. If the output tube is a 6AU5 or 6BD5, the plate is at the socket and this test becomes inconvenient. The alternate procedure used then is to listen for the characteristic whistle of the horizontal sweep. It will be easier to hear this by listening for the change in pitch when the hori-

(Continued on page 45)

Element	Pin #	Voltage	Remarks
Filament	1, 12	6.3 A.C.	Filament current .6 Amp.
Cathode	11	0	CRT DC voltages are taken to cathode
Grid	2	0 to -80V	Full brightness to cut-off
1st Anode	10	300V	
Focus anode	6	-50 to 300	17H, L, R, TP4; 20HP4; 21FP4; 24BP4; 27AP4
Focus anode	6	3,000 to 4,000	14GP4; 17G, FP4; 20FP4; 20GP4
High voltage	cap	8,000 to 16,000	Varies with size, about 800V per inch
High voltage	cap	25000V	Projection tubes and 30 inch tube

Fig. 3—Chart listing normal voltages to be expected at CRT.

calibration for the meter would be required, since the voltage is in pulse, not sine-wave form, and the frequency is 15,750 cycles with high harmonic content beyond the range of most shop instruments.

A calibrated spark tester may be used for this HV test, with the voltage measured at the point at which the spark makes. This is important, since the

plate. If a spark of normal length is obtained at the lead, the trouble is in the rectifier cathode circuit.

In the case of voltage-doubler circuits, the most frequent component, next to tubes, that causes trouble is the resistor from the cathode of the first tube to the plate of the second. If this resistor is defective, the spark at the plate of the first tube may be normal when the sec-

# Check List of

If You Overlook Likely Sources of Trouble When

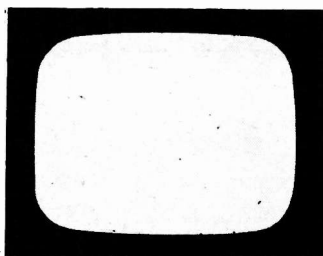

1—Normal raster

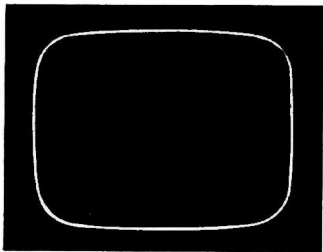

2—No raster, screen dark

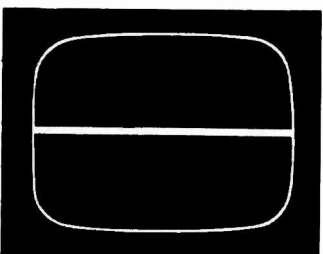

3—Vertical deflection absent

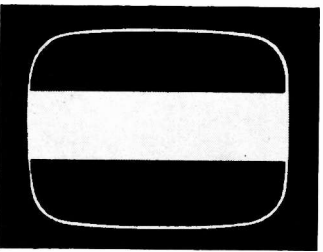

4—Insufficient raster height

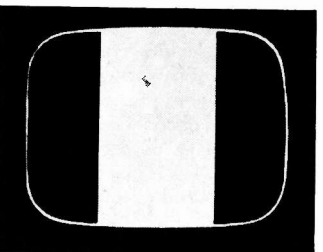

5—Insufficient raster width

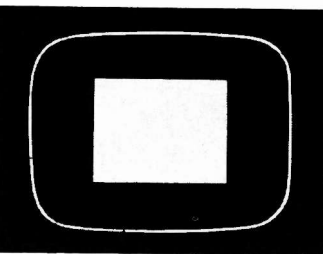

6—Insufficient height and width

GENERAL TROUBLE	PRIMARY SYMPTOM	ASSOCIATED SYMPTOMS	POSSIBLE CAUSES OF THE TROUBLE
DEAD SET	No Raster or Sound.	Tubes don't light.	Line Cord Plug doesn't make good contact in Outlet. Defective Outlet. Interlock Connector defect, or Contacts poor. Line Cord or Plug defective. Off-On Switch NG. Fuse in Low-Voltage Rect. Circuit open. Open Primary in Power or Isolation Transformer.
		Some Tubes light, others don't.	Open Tube Filament (in Sets with Series-Parallel Tube Filament Hook-ups). TV-FM-Phono Switch (in Combination Sets) in wrong setting, or defective.
	All Tubes Light.	Low-Voltage Rect. Tube Defective. Short or Open in "B" Line.	
VERTICAL DEFLECTION ABSENT or INSUFFICIENT	Bright Hor. Line on Screen, No Raster.	Unlit CRT →	Brightness Control Setting incorrect. Fuse in HV Section open. Ion Magnet improperly set or defective; wrong Ion Magnet. CRT 2nd Anode Lead defective, or making poor contact. CRT or CRT Filament Supply defective. CRT Socket defective, or making poor contact with CRT. Yoke Plug loose or disconnected. Bad contacts on TV-Phono Switch. Defect in HV Rect., Hor. Output, Damper, Discharge, Hor. Osc. Tube or Circuit. HV Transformer Section defective. Open Resistor in Filament Circuit of HV Rect. Leaky Coupling Capacitor in Hor. Deflection Circuits. Hor. Output Transformer defective, or wrong type. Improper Voltages on CRT Elements (Excessive CRT Bias, etc.) Grounded Hor. Yoke Winding. Defective Sync Discriminator or Horizontal Osc. Control Tube or Circuit. Shorted or Leaky HV Filter Capacitor. Open HV Filter Resistor. Incorrect Drive Control Setting. CRT defective.
			Height Control Setting incorrect. Vertical Osc. Tube or Circuit defective. Vertical Output Tube or Circuit defective. Vertical Osc. Transformer open or shorted. Vertical Output Transformer open or shorted. Vertical Yoke Coils open or shorted. Defective Vertical Hold, Size or Linearity Control.
	Raster Collapses in Vertical Direction Intermittently.	Vertical Osc. or Amp. Tube defective (particularly 6BL7GT). Condenser across Secondary of Vert. Output Trans. shorts intermittently. Vertical Output Transformer defective. Poor connections at Terminals in Vert. Osc. and Amp. Circuits.	
HORIZONTAL DEFLECTION ABSENT or INSUFFICIENT	Bright Vert. Line on Screen.		Height Control Setting incorrect. Vertical Output Tube or Circuit defective. Vertical Osc. Tube or Circuit defective. Coupling Capacitor between Vert. Osc. & Amp. leaky. Vertical Osc. Charge-Discharge Capacitor leaky. Shorted Turns in Vert. Output Transformer Primary.
	Raster Height Insufficient.	Vertical Non-Linearity often Present.	Height Control defective.
	Raster Width Insufficient.	Horizontal Non-Linearity may be present.	Open in Horizontal Yoke or Yoke Circuit. Defective Horizontal Output Tube.
RASTER SIZE INCORRECT (HEIGHT AND WIDTH IMPROPER)	Raster Size Below Normal.	Focus may be improper. → Size reduced at least 1/8" on top, bottom and sides. Focus control provides optimum focus at extreme setting, or possibly doesn't go through proper focus at all.	Horizontal Drive Adjustment incorrect. Width Adjustment incorrect. "B" Supply Voltage below normal. Horiz. Output Transformer defective. Horizontal Osc., Discharge, Damper, Hor. Amp. Tube or Circuit defective. Increase in Hor. Output Transformer Air-Gap due to insufficient tightening of the Screw Bolt between Outer Supporting Plates of this Transformer. Broken Slug inside Linearity Coil or Size Control Coil. AC Line Voltage too low. Height and Width Adjustments improper. "B" Voltage below normal. CRT defective (presence of gas may decrease the tube's deflection sensitivity). Sweep Amplifier Tubes weak. Weak Low-Voltage Rectifier.
	Raster size excessive. Pix too large for mask.	Brightness below normal. → Raster increases in size, decreases in brightness, possibly defocuses, as brightness or contrast setting is advanced.	Height and width adjustments incorrect. High voltage below normal. Defective HV Rectifier Tube. HV Filter Resistor has increased in value.

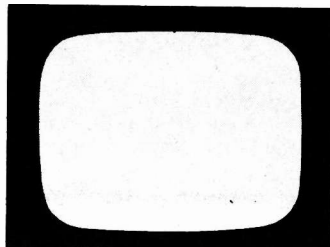

7—Vertical non-linearity at end of sweep

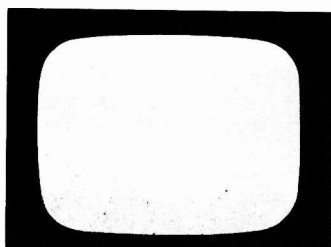

8—Vertical non-linearity at beginning of sweep

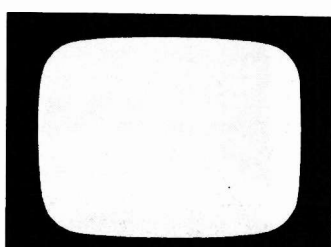

9—Horizontal non-linearity at end of sweep

# Raster Defects

*the Pressure is on, Keep This Chart Handy*

GENERAL TROUBLE	PRIMARY SYMPTOM	ASSOCIATED SYMPTOMS	POSSIBLE CAUSES OF THE TROUBLE
RASTER ILLUMINATION IMPROPER	Brightness insufficient.	Insufficient width, poor Hor. Linearity. Raster size normal. Pix size excessive. → Raster size below normal. → Blue haze may be seen in CRT.	Horizontal Drive, Size or Linearity Control Setting improper. Horizontal Output Tube defective. Damper Tube defective. Increase in HV Filter Resistor. Open or Leaky HV Filter Capacitor. HV Rect. Tube or Circuit defective. "B" Voltage below normal (due to weak rectifier tube or circuit trouble). CRT weak. CRT bias excessive; or other CRT element voltages are improper. Ion Magnet improperly positioned or defective.
	Brightness excessive.	Brightness control has no effect.	CRT defective. Trouble in CRT circuit (open in brightness control, if latter is in CRT grid circuit; shorted or leaky coupling condenser between video amp and CRT).
	1 or 2 thick black horizontal bars in Raster (Hum).	Hum may be present in sound; Raster's horizontal sides may be wavy.	Open or Partially-Open Condenser in "B" Supply. Cathode-Heater Leakage in Video Amp, Video Detector, CRT; or in Video 1F, Front-End Tubes.
	Horizontal white bar at bottom of Raster.		Vertical Osc. or Output Tube defective. Low line voltage. Low "B" voltage (Rectifier Tube weak or defect in circuit). Shorted or leaky Cathode Bypass Condenser in Vertical Output Stage.
	Vertical white bar at left or right-hand edge of Raster		Horizontal Drive Setting incorrect. Horizontal Linearity Setting incorrect. Horizontal Output Tube or Circuit defective. Damper Tube or Circuit defective.
	Vertical white line near center of Raster.		Horizontal Drive Setting incorrect.
	Vertical lines at left-hand side of Raster.		Parasitic oscillation in Hor. Output or Damper Circuits, due to defect in tube. Open in Resistor or Condenser across one of the Hor. Yoke Windings. Units may have wrong value. Horizontal Drive Setting incorrect. Damper Tube or Circuit defective. Open "Boost" Capacitor in Damper Circuit.
	Vertical bars on right-hand side of Raster.		Horizontal Oscillator, Output or Damper Tube defective.
	Light and dark vertical bars in Raster.	Horizontal Linearity improper.	Damper or Horizontal Output Tube or Circuit defective. Horizontal Drive Setting improper.
RASTER FOCUS IMPERFECT	Proper focus cannot be obtained.	Focus control has no effect.	Open or Shorted Turns in Focus Coil. Component defect present that is causing current drain through Focus Pot to be excessive or insufficient. Short or open in Focus Pot. CRT gassy or otherwise defective. Defect in CRT Socket. Ion Magnet improperly set or defective. Focus Magnet not properly located or centered. Wrong or defective Focus Magnet present. HV improper. Magnetic Centering Device (on Electrostatically-Deflected Tubes) 180° out of position.
RASTER SHAPE INCORRECT	Raster's hor. sides are wavy with contrast setting low.		Cathode-Heater leakage in Sweep Amp. or Sync Tubes.
	Trapezoidal or Non-Symmetrical Raster.		Shorted Turns in Deflection Yoke. Short in Yoke Shunt Capacitor. Improper adjustment of Focus or Ion Magnet. Defective Focus Magnet.
	Shadowed or Rounded Corners on Raster.	Brightness normal. → Brightness insufficient. →	Deflection Yoke too far back on CRT neck. Centering Adjustment incorrect. Ion Magnet Setting improper. Ion Magnet Setting improper.
	Distorted Raster.		CRT too close to Speaker.
	"Xmas-tree" effect in Raster.		AFC Tube defective. AFC Adjustments improper.
RASTER NOT CENTERED			Deflection Yoke Setting incorrect. Centering Magnets improperly positioned. Defective CRT. Defective Ion Magnet.
RASTER LOOKS "ROUGH"			Parasitic Osc. in Horizontal Amp. due to defect in latter. Horizontal Amp. Plate Cap Connection poor.

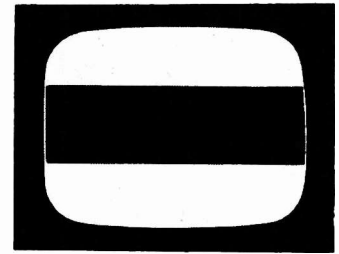

18—Non-uniform raster illumination due to hum

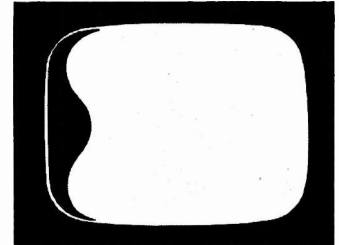

17—Wavy side in (decentered) raster due to hum

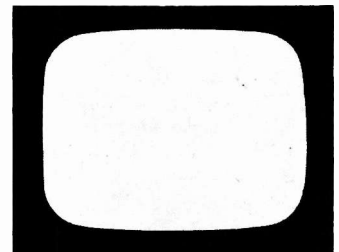

16—Vertical bars in raster

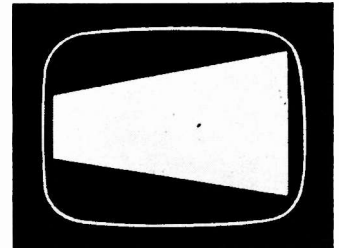

15—Trapezoidal raster caused by fault in vertical yoke circuit

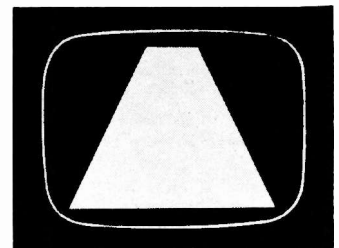

14—Trapezoidal raster due to fault horizontal yoke circuit

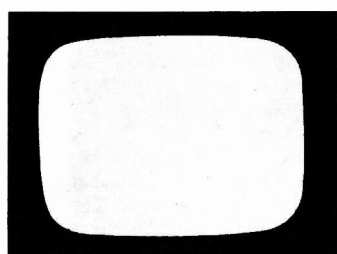

10—Horizontal non-linearity at beginning of sweep

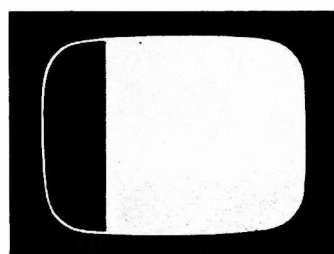

11—Raster decentered horizontally

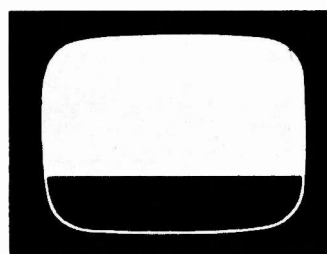

12—Raster decentered vertically

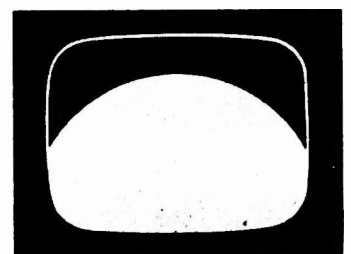

13—Shadowed corners in raster

# Dynamic Cathode-Ray

Why a Simple Emission-Type of a CRT is Inadequate.

• Technicians not infrequently make incorrect diagnoses of the condition of a cathode-ray tube. Incorrect interpretation of the readings obtained with emission-type CRT checkers is often responsible. We can cite as an example the case where a CRT performs with no brilliance, due to a fault in the socket—say, an open cathode connection. The technician checks the operating voltages on the CRT and finds them normal. The picture tube itself is then checked. An emission reading of *low* is obtained. The technician concludes that the CRT is the source of the trouble, replaces it, then finds he is back where he started from.

In another instance, he may check a CRT that tests *good* on an emission

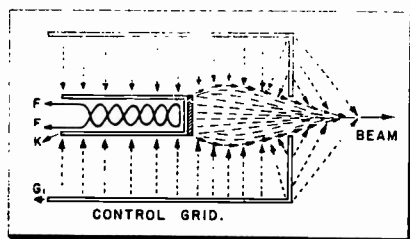

Fig. 1—CRT cathode-grid section (much enlarged).

check, but is actually *poor* in set operation.

What is obviously needed is a cathode-ray tube test under *dynamic*, or operating conditions. This article describes a way of making such a check.

Examine Fig. 1. This is the cathode-grid section of the CRT enlarged. Instead of the simple conception of a cathode releasing electrons through a grid peep-hole we find a complex network of electrostatic forces acting upon the electron beam. The geometry of the individual gun structure, the degree of evacuation of gas and the chemical composition of the gun elements affects the degree of control exercised by the grid on the electron beam.

## Grid Control

The washed-out 'flat' picture associated with a faulty picture tube is less a problem of insufficient screen excitation than it is *faulty control* over the excitation available. Yet little attention is normally paid to the quality of grid control, the emphasis being placed on 'how much current.'

The quality of grid control is a difficult factor to determine over a wide range of operation. It is quite simple, however, to measure it at the point of greatest significance—at cut-off. Mathematically speaking, the degree of change

of light or grid-control at high brightness settings is slight. For example, a bias change of 15 to 20 V may be needed to effect a 2:1 change in brightness at a high brightness setting. At a lower brightness setting, however, a bias change of only 6 V may be needed to effect the same 2:1 variation in brightness. Just above cut-off, a 2:1 ratio in brightness can be accomplished with a variation of only ½ volt . . . control thus varying logarithmically as cut-off is approached. This is carried to the point of exact cut-off where a 2:1 ratio of brightness can be accomplished at a voltage increment hardly measureable on shop instruments.

This indicates that for analysis of maximum control action of the grid upon the electron beam we have but to measure the cut-off point of the picture tube under discussion.

## Cut-off Voltage Measurement

This is quite practical in the field. Ambient light is removed by drawing the blinds, then the brightness control is rotated until screen brightness is extinguished. At this point measure the  $G_1$  to K voltage and you have the *cut-off voltage*.

There is a definite relationship between cut-off and emission. Picture tubes having a low cut-off (i.e. . . . requiring a low negative voltage on the grid to extinguish the beam) will give

tube with the low emission reading. The emission readings of tubes that provide the same brightness may thus be considerably different. The high cut-off tube might easily have a measured emission twice or three times that of the lower cut-off tube, and still perform no better than the latter.

## Grading CRT's

By properly relating cut-off and measured emission, an exact qualitative figure of merit may be achieved to definitely grade any picture tube. For example, take a 10BP4 whose cut-off voltage is measured at 30 volts. If the cathode emission is measured at 0.1 ma. the tube is *poor*. If the emission is 0.2 ma. the tube is *fair*. If beam current goes to 0.3 ma. the tube is *good*. When the measured emission of such a tube is 0.4 ma. the tube is *very good*. If you can get 0.5 ma. (500 microamps) of beam current the tube may be properly classified as approaching *excellent*.

To make a CRT dynamic analysis, proceed as follows (a VTVM should be used for all voltage checks):

(1.) Measure (using the appropriate AC scale) the filament voltage of the operating picture tube. The nominal 6.3 volts may vary up to 10% under actual load. A variation of 20% or more is abnormal. Variation of 2 or more volts between load and no-load conditions of the picture tube filament indicates poor

Cut-off voltage	Emission in MILLIAMPERES									
	.100	.200	.300	.400	.600	.800	1.000	1.300	1.600	1.900
30v	POOR	FAIR	GOOD	VERY GOOD	EXCEL.	EXCEL.	EXCEL.	EXCEL.	EXCEL.	EXCEL.
40v	VERY POOR	POOR	FAIR	GOOD	VERY GOOD	EXCEL.	EXCEL.	EXCEL.	EXCEL.	EXCEL.
50v	VERY POOR	VERY POOR	POOR	FAIR	GOOD	VERY GOOD	EXCEL.	EXCEL.	EXCEL.	EXCEL.
60v	VERY POOR	VERY POOR	POOR	POOR	FAIR	GOOD	VERY GOOD	EXCEL.	EXCEL.	EXCEL.
70v	VERY POOR	VERY POOR	POOR	POOR	FAIR	GOOD	GOOD	VERY GOOD	EXCEL.	EXCEL.
80v	VERY POOR	VERY POOR	POOR	POOR	POOR	FAIR	GOOD	GOOD	VERY GOOD	EXCEL.

(COURTESY OF ELECTRONIC BEAM CORP.)

Fig. 3—Table relating CRT cutoff voltage and emission.

a low emission reading (in a CRT checker) even though the cathode is giving *normal emission* for that tube. Yet, such a "low emission" tube may operate perfectly in a TV set.

A second tube, having a *higher* cut-off will give a much higher emission reading, even though its performance may be no better than the low cut-off

regulation. This filament check is always indicated when the normal filament light cannot be readily seen in the picture tube neck.

(2.) Measure CRT emission as follows: (Make temporary hook-up as shown in fig. 2.) 1—Connect positive terminal of VTVM to CRT cathode. 2—Connect CRT cathode to CRT  $G_1$ . 3—

# Tube Analysis

## More Accurate Method of Locating Defective Picture Tubes.

Open  $G_1$  circuit from CRT socket to set. Leave  $G_2$  circuit alone. (It may be assumed that regular B+ is being applied to  $G_2$  terminal.) 4—Lift off the anode lead from the CRT. Leave it hanging, where it cannot arc to chassis. 5—Open CRT cathode return to chassis. Connect the chassis side of the cathode lead to negative terminal of VTVM. 6—Hook up a 1,000 ohm resistor across VTVM terminals. 7—Turn the set on.

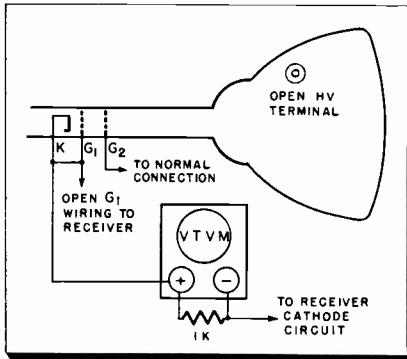

Fig. 2—Connections for CRT emission test.

Using the lowest DC voltage scale on the VTVM, read the voltage developed, but call it *milliamperes*. Thus, if the scale shows 0.76 volts, call it 0.76 mils (760 microamps). In this case, the tube would show 0.76 milliamperes of cathode emission under test.

### Experimental CRT Checker

Considering this in further detail: By removing the anode lead, we've eliminated that element from the circuit. Tying the control grid to the cathode eliminates this grid's action—which leaves in the test circuit only the cathode and  $G_2$ .

The VTVM measures the voltage drop across the 1000 ohm resistor. By Ohm's Law,  $E = IR$ . When the resistor is 1000 ohms, the formula is  $E = 1000 \times I$ . Now, since  $I$  is in amperes,  $1000 \times I =$  milliamperes. Therefore  $E$  (in volts) =  $I$  (in MA). For every volt, then, there will be 1 MA flowing in the CRT circuit. Thus we get the true current reading with a voltmeter.

We now have an experimental CRT checker, with which we can measure picture tube emission between cathode and  $G_2$ . Of course that emission reading is meaningless unless we have standards to compare it with. The chart in fig. 3 provides such standards.

To make a dynamic check of a cathode-ray tube, its emission should first be determined, as described above. Its

cut-off bias should next be measured. To do so, proceed as follows:

With the picture tube operating normally, lower the blinds and turn off all room lights. Now, watching the raster (without signal) vary the brightness control until the screen goes completely dark. The control setting is now at cut-off. With the VTVM, measure the voltage between  $G_1$  and cathode. Mark this down as *cut-off voltage*. It will, of course, be negative.

By inspecting the chart, it can now be readily determined in which category the tube falls. Let's consider some sample cases. Suppose a tube has an emission of .3 MA, and a cut-off voltage of  $-30$ . These two ratings intersect in a box labeled GOOD. If a tube with the same emission had a cut-off of  $-80$  V, it would fall into the box labeled POOR.

### G<sub>1</sub> Correlation Factor

If it is desired to avoid cutting into the circuits of the receiver to get the required readings, a simple inexpensive adaptor can be made up, much like the analyzer adaptors used in old-time radio testers, in using which a tube was removed from the set, the adaptor inserted in its place, and the tube plugged into the adaptor.

The need for making the measurements described, as well as adaptor rig-up, can be dispensed with by using one of the commercial CRT checkers available that is capable of making such a dynamic CRT analysis.

The table shown in fig. 3 was set up for tubes with a  $G_2$  voltage of 300. If the  $G_2$  voltage of the CRT under test is other than 300 V, the table in fig. 4 will have to be consulted. Find the  $G_2$  voltage closest to the one actually present in the left-hand column of the table and note the *Correction Factor K* inserted next to this voltage. The *cut-off voltage and emission current of the CRT under test should both be multiplied by the K value*. The table in fig. 3 is then used, as before, to evaluate the condition of the CRT.

### Sample Analysis

Let's illustrate the procedure, assuming a tube with a  $G_2$  voltage of 335 V. Inspecting Table B, we find that the listed  $G_2$  voltage closest to 335 V is 325 V. The Correction Factor  $K$  for this voltage value is .95. Now, suppose that the measured CRT emission averages .4 MA, and the cut-off voltage is 60 V. Multiplying each of these two values by the .95 Correction Factor changes them to .38 MA and 57 V, respectively. Since .38 MA is much closer to .4 than it

is to .3, we start at the top of the .4 MA column (Table C) and move down vertically. 57 V falls between 50 and 60 V—the tube is therefore between *fair* and *poor*, and nearer to *poor* than to *fair*. If the final current value had been .35 MA, we would have determined the tube's "dynamic merit" at .3 MA, then found what it was at .4 MA. Its actual "dynamic merit" would have been about midway between the two.

(EDITOR'S NOTE: Several cathode-ray tube engineers have added some *ifs*, *ands*, and *buts* to the writer's basic thesis that "if two tubes have the same cathode emission, the one with the lower cut-off bias is the better tube.")

The engineers say: "Of two picture tubes having the same emission, the

Table B  
CUT-OFF VOLTAGE  
Correction Factor K

$G_2$ voltage	K
150	2.0
175	1.6
200	1.5
225	1.3
250	1.2
275	1.1
300	1.0
325	0.95
350	0.85
375	0.80
400	0.75
425	0.70
450	0.65

(COURTESY OF ELECTRONIC BEAM CORP.)

Fig. 4—Correcting for different  $G_2$  voltages.

one with low cut-off bias has higher modulation sensitivity and is therefore better on weak signals, but is limited in light output capability; the one with the high cutoff bias requires more grid drive, but when adequate signal is available, greater light output will be obtained. Any appreciable drop in emission and consequent reduction in brightness will be more noticeable in a high cutoff tube than in a low cutoff tube.")

# What to Expect in

## Changes Ahead. 1N60 Video Detector, Direct-Coupled Video Amplifier, Intercarrier Sound, and Exceptionally Well-Designed AGC and Sync Circuits Will Probably Be Used in Sets Intended for UHF Reception.

video amplifiers and intercarrier sound operation.

### High Forward Conductance

**Video Detector:** The germanium diode 1N60 is particularly suited to video detector application because of its high forward conductance, its low intrinsic capacitance and high back resistance (allowing good wideband operation).

**Direct-Coupled Video Amplifier:** Of all video amplifiers thus far used, that type which is direct-coupled to a negatively-polarized second detector can

The block diagram indicates that the AGC, the synchronizing circuits, i-f amplifier and, of course, the tuner require modification or new design.

**AGC:** The AGC system should be the best possible since fading can be more severe on UHF than on our present television channels. For example, due to the sharper shadow regions—less diffusion of the wave front around obstacles—airplane flutter can produce larger ratios of signal strength change. Some keyed automatic gain control circuits may improve the stability of the background and brightness level for both rapid and

With 2000 UHF stations possibly coming into operation in the not-so-distant future, the TV technician should acquaint himself with UHF-inspired changes in receiver design that are being made or contemplated.

The first basic question that might be considered is: what chief factors will affect the over-all design of sets intended to receive UHF signals?

It is known that the signal voltages at the receiver terminals will be lower than on VHF for similar transmitted powers and distances from the transmitter, yet the operating frequencies are such as to make good radio frequency amplifier design quite difficult. Measurements made from the Empire State Building on 910 mc in 1947; by G. H. Brown in Washington in 1948; and numerous field surveys of the Bridgeport Station show that for the same fringe area reception as on 60 mc, from 100 to 1,000 times the effective radiated power is required. Also, the noise factors of typical r-f amplifier circuits become worse as the operating frequency increases.

Hence, particular emphasis is immediately placed upon careful design of the input circuits of the receiver.

What, if any, demands will UHF make on other sections of the receiver? This question will be answered by discussing the overall design of a combined or composite U and V receiver.

### Unchanged Functions

The standards approved for UHF transmission are the same as for VHF. Hence, there are many sections of a combination UHF and VHF television receiver whether for monochrome or color whose design will be unaffected by the new frequency allocations.

In Fig. 1, those sections which do not require change are shown in dotted outline. Because of the standardization with VHF above mentioned, the video detector, the video amplifier, horizontal AFC, deflection circuits, sound system and supply voltage sources need no basic changes. However, there may be advantages in using a germanium diode, such as the type 1N60, for the video detector. It may also be of interest to discuss the characteristics of direct-coupled

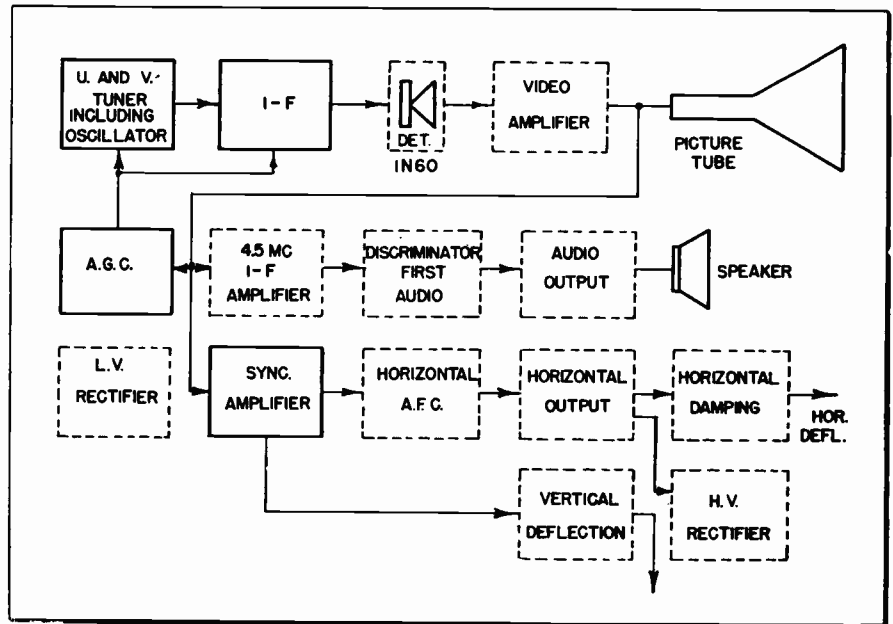

Fig. 1—Sections not requiring change in new UHF and VHF receivers are shown in dotted-lines.

best provide reduction in the amplitude of incoming noise pulses, so that the synchronizing amplifier receives a smaller range of undesired voltages. Such direct-coupled video amplifiers provide a definite improvement in the contrast range of the reproduced picture. Also, the low video frequency response is excellent since there is no phase shift even at DC. It is to be noted that these characteristics of DC-coupled video amplifiers are independent of the use or non-use of AGC.

**Intercarrier Sound:** As has so often been mentioned before, the intercarrier sound system can give ease of tuning combined perhaps with less audio noise between channels. This is quite important on UHF where the great number of channels and the wide spaces between those which are active in a given location will make tuning difficult.

slow variations of the signal amplitude.

**Synchronizing Circuits:** These should also be of the best possible design to reduce the effects of rapidly fluctuating signals and such interference as may occur due to cross-modulation. Cross-modulation may occur more readily at UHF due to the poorer discrimination against nearby channels by the limited number of tuned radio frequency circuits, and can produce additional synchronizing pulses with incorrect time delay.

**The I-F Amplifier:** The intermediate frequency is, in part, chosen for:

- the best image rejection,
  - minimum power in the beat frequencies between harmonics of the i-f and the incoming signal,
  - minimum local oscillator radiation.
- These three requirements call for a much higher frequency than has been

# UHF-VHF Receiver Circuits

used in the past; yet the frequency has to be made as low as is feasible in order to provide:

- d. low noise factor,
- e. good gain for a given number of stages, and
- f. avoid regeneration on the low channels of the VHF band. That is, if the intermediate frequency approaches the region of 54 mc, it would be very difficult to avoid regeneration when tuned to channel 2.

It is to be noted, that going from an i-f frequency below channel 2 to one in the region of 120 mc degrades the noise factor of the i-f amplifier by at least 2 db. Also, an intermediate frequency higher than channel 2 can lead to difficulties in mixer and local oscillator design for the VHF portion of the combined V and U receiver. Hence, it seems that the choice of the i-f amplifier for complete U and V tuners should be in the frequency range as close to channel 2 as is consistent with reasonable freedom from regeneration.

The intermediate frequency proposed by the RTMA—41.25 for sound, 45.75 for the i-f picture carrier—is a reasonable choice. The frequency ranges chosen lie in a part of the spectrum where very few and only low-power radio transmitters operate (with the exception of some—we hope temporary—police transmitters). Other characteristics of the i-f amplifier will be discussed later.

## UHF Tuning Section

Due to the large number of channels possible between 470 and 890 mc (70) as compared with the twelve of the present band, there are various schools of thought regarding the mechanical operation of the tuner.

It may be of interest to classify possible mechanical designs under three headings, shown in Table 1.

- a. Continuously tunable—examples of this are DuMont, RCA, and Mallory.
- b. Semi-Continuous—what may be called a "band-spread" type, in which a switch chooses various zones of the UHF band and a dial actually tunes in the channels in each zone.
- c. Selector Switching—where a choice of perhaps any six up to eleven UHF channels may be pre-set and then are tunable along with 7 or less VHF channels by the same selector switching as we have on the majority of VHF receivers.

Continuous tuning has many advocates since it is possible to choose any of the 70 possible channels between 470 and 890 mc, despite the fact that there are no locations planned where even 50% of these channels will be within a useful radius. (Example: the whole state of Pennsylvania with only 48 UHF proposed station allocations, whereas there are 70 channels to be tuned.) Con-

**TABLE I**  
**UHF TUNER CLASSIFICATIONS**

**A—Continuous Tuning with Oscillator at Fundamental Frequency**

**B—Rotary Switch for Sectional L and C Change with "Band Spread" by Capacity Tuning.**

**C—Rotary Switch with VHF Oscillator and Crystal Harmonic Generator. Usually of Turret Type with Pre-Set Channels.**

### Methods of Tuning

1. Movable Core—Variable L and C
2. "Butterfly"—Cylinder or Ring
3. Sliding Contact

tinuous tuning from 470 to 890 mc requires a precision mechanism and dial to enable sufficiently accurate tuning for best picture and sound. The most desirable system, perhaps, would provide selection by means of pre-set channel positions similar to the method used in the majority of present day VHF receivers. However, when the number of channels reaches 70, it is impractical to have this many fixed positions on one switch.

Plans are underway for tuners which may give 18 to 20 of mixed VHF and UHF channels chosen to suit the particular locality. This becomes entirely practical when the local oscillator operates in the VHF region and the UHF mixer operates with an equivalent local oscillator signal obtained from harmonics of the local oscillator. Surprisingly large harmonic powers are available from conventional VHF tube sources, e.g. one section of a 6J6 oscillator, by using a germanium or silicon diode as the harmonic generator. Of various types, the 1N34, 1N34A and 1N82 appear to be the most satisfactory, producing powers of 60 milliwatts at 500 mc and 30 milliwatts at 900 mc. This arrange-

ment, in combination with the new silicon diode, type 1N82 (used as a mixer), provides a very stable-frequency harmonic oscillator-mixer combination.

## Tuner Electrical Design

It may be of interest to summarize the basic sections of UHF tuners by dividing them into two groups:

- a. The fundamental oscillator continuously tunable type,
- b. harmonic generation of the local oscillator frequencies, possibly together with selector switch tuning.

Fig. 2 shows the block diagram for these two basic groupings.

Both types require a high-pass filter between the antenna and the first UHF tuned circuit, to reduce interference from VHF, FM, short-wave and broadcast stations. Such a high-pass filter cuts off, or should cut off as sharply as possible below 450 mc. Next is the radio-frequency circuit, preferably double-tuned, so as to carefully match the antenna to the input impedance of the r-f amplifier tube or the mixer. Following this, there should be a radio-frequency amplifier tube with its output tuned circuit coupled to the mixer. Next, the mixer crystal with the output i-f circuit and the local oscillator with or without the harmonic generating crystal and tuned circuit. Both the r-f and mixer tuned circuits should provide as high a discrimination against nearby local television channels as possible in order to avoid cross-modulation. Then, the image selectivity will also be adequate.

A first stage of good quality radio frequency amplification is most desirable: (1) to reduce the local oscillator coupling to the antenna; (2) to improve as far as possible, the noise factor, thereby increasing the useful range of the transmitter; (3) provide increased image rejection and, also; (4) reduce cross-modulation at the mixer.

Suitable r-f amplifier tubes at acceptable prices are, however, not presently available.

## I-F Amplifier; Antenna

If no r-f amplifier is to be included; and so far no commercial tuner covering the whole UHF range (470-890 mc) has an r-f stage—then it is particularly important to have a quiet first stage of intermediate frequency amplification. This stage should have the lowest possible noise factor to make full use of a silicon mixer, since the i-f voltage at the output of the mixer is lower than the r-f signal voltage applied to it.

The antenna is carefully matched to the transmission line to obtain the best overall noise factor. Any tube fluctuation noise transferred to the first tuned circuit together with thermal noise in this circuit is thus absorbed by the an-

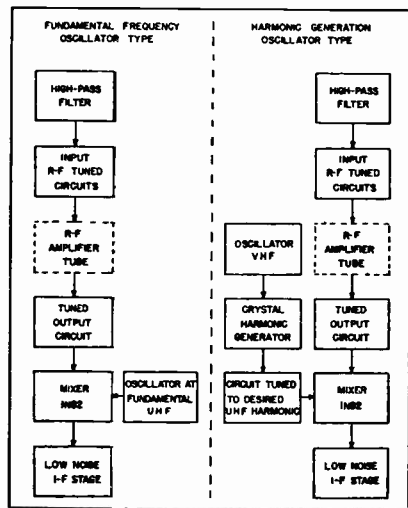

Fig. 2—Two groupings that represent basic divisions of UHF tuners.

(Continued on page 46)

# UHF Reception on VHF

## Description and Analysis of Mallory Converter, Raytheon

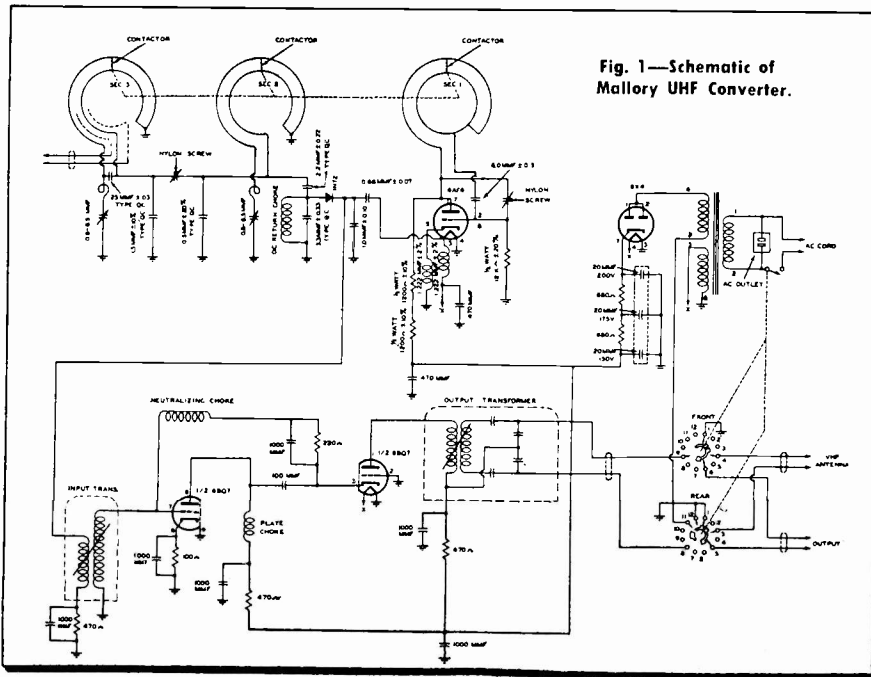

Fig. 1—Schematic of Mallory UHF Converter.

A representative converter circuit is shown in fig. 1. The first preselector circuit, redrawn into simpler form, is shown in fig. 2A. (The second preselector circuit is the input to the mixer.) The circuit may be redrawn once more, using symbols more familiar to the ser-

viceman (fig. 2B). Note that this first tuned network is grounded at both ends—i.e., at  $G_2$  and at  $G_1$ . This brings up the question, how can signals be developed across the two coils, if they are short-circuited?

The answer is, the short is effective only at relatively low frequencies, and is intended to eliminate or reduce low-frequency interference and oscillator radiation. For UHF signals, sufficient inductive reactance is present in the circuit, in spite of the grounds at both ends, to permit UHF voltages to be developed here.

Tuning is continuous, and is achieved in this, as well as in the mixer and oscillator circuits, by rotating the shorting bar back and forth, thus varying the amount of inductive reactance present in the circuit.

The inner concentric conductor is connected back onto itself, to avoid an undesired resonance, or suck-out, at approximately 780 MC (fig. 2C). The transmission line is capacitively-coupled to the preselector tuning inductor by the proper placement of two small arcs of silver ribbon on the back side of this inductor. The equivalent circuit present is shown in fig. 3.

The transmission line is applied to each inductor section through a capacitance labeled  $C_1$ . The two condensers labeled  $2C_1$  represent the capacitances present between the conducting sections

Fig. 4—A) Schematic of Raytheon UHF Tuner. B) Pictorial sketch of Raytheon UHF Tuner. Note drive-gear meshing of VHF and UHF tuning units.

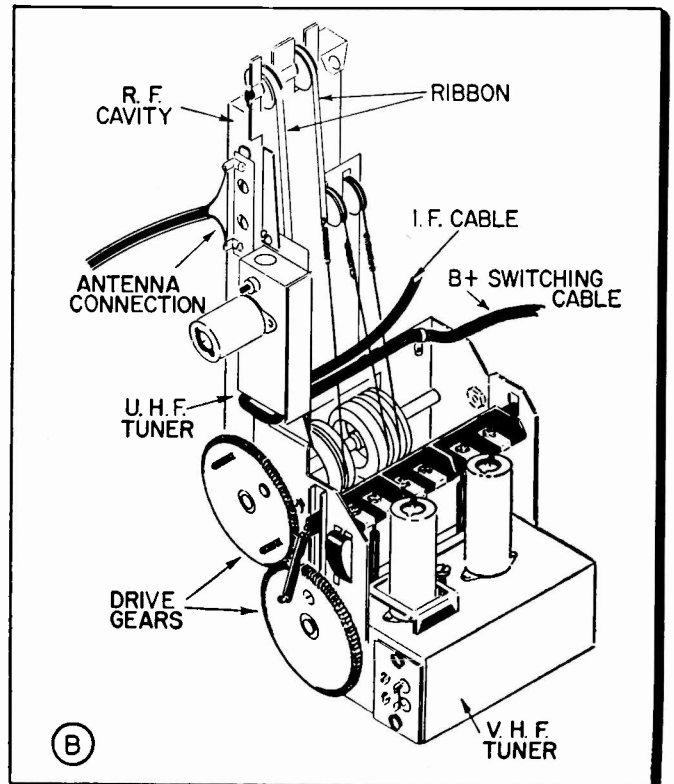
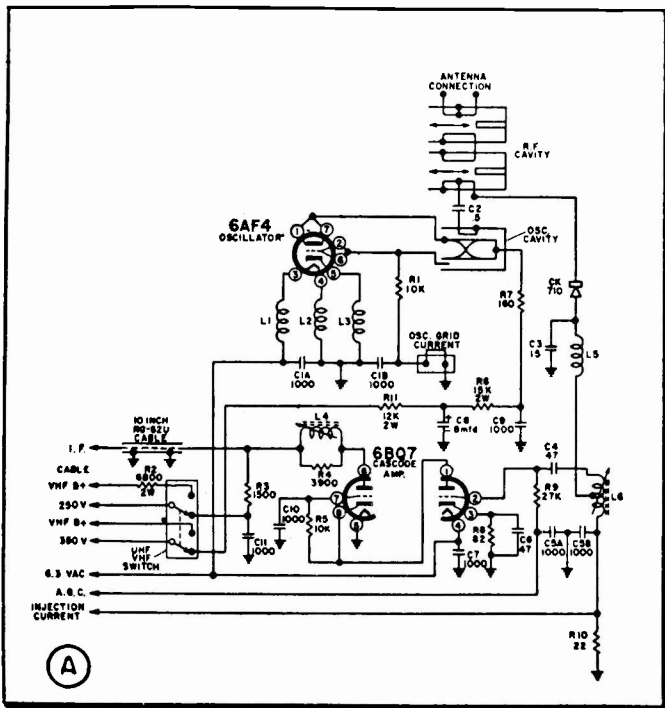



# Television Receivers

## Tuner and Stromberg-Carlson Television Converter

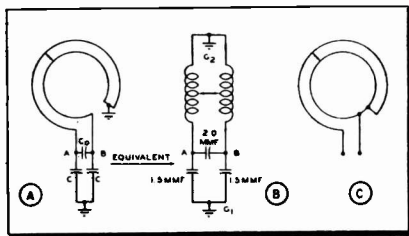

Fig. 2—A) First preselector circuit of schematic shown in fig 1. B) Circuit redrawn into more conventional form. C) Inner concentric conductor in oscillator circuit is connected back onto itself, to avoid undesired resonance effects at approximately 780 MC.

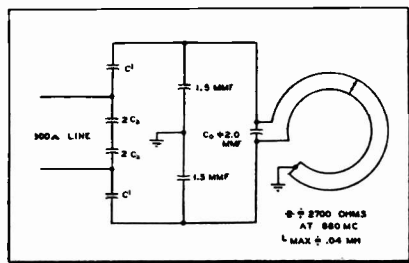

Fig. 3—Equivalent input circuit of Mallory UHF Converter. 300Ω line connects to antenna.

of the line. The circuit arrangement provides an impedance step-up that permits the low impedance of the antenna and the transmission line to be matched to the higher impedance of the preselector tuned circuit. The low impedance input of the line, in other words, is kept from loading down the preselector tuned circuit by the isolating effect of the two  $C_1$  condensers.

The tuner has three sections, to tune the first preselector, mixer and oscillator circuits.

The oscillator output voltage is developed across the oscillator cathode coil, and is fed into the mixer by means of the heater-to-cathode capacitance present in the oscillator tube—an arrangement which will no doubt seem unfamiliar to many servicemen. It is used because it readily provides the very small capacitance desired—about 2.7 mmfd. A very small capacitance is needed between the mixer and oscillator circuits to better isolate the one from the other, and prevent undesired reactions between the two.

Suitable condensers are inserted before and after the mixer crystal, to match its impedance to the RF circuit that precedes it, and the first IF circuit that follows it. The output of the mixer is fed through a double-tuned transformer into a cascode (low-noise) IF amplifier. The amplifier consists of a triode input tube with a very small cathode bias, coupled to a grounded-grid output tube.

Neutralization is used, since triodes are inherently unstable when operated as amplifiers at high frequencies. Feedback from the output to the input of the first triode through a neutralizing choke opposes the in-phase or regenerative feedback that tends to occur between plate and grid in this tube. The grounded grid in the second triode provides a shielding effect that makes neutralization of this amplifier section unnecessary. Neutralization makes it possible to get more gain out of the IF amplifier, and thus improve the signal-noise ratio, without driving the amplifier into regeneration.

The bandpass of the IF circuit is approximately 12 MC at the half-power points on the response curve. The output transformer of the IF amplifier section feeds through the switch into the low-impedance antenna input circuit of the VHF receiver. An unusual amount of filtering and decoupling is employed, to keep RF voltages out of the power supply.

A UHF tuner schematic is shown in

fig. 4A. The physical appearance of the tuner is indicated in fig. 4B. It is installed in the VHF receiver as follows:

A drive gear is mounted on the VHF tuner. The UHF tuner is then mounted over the VHF unit by means of four mounting screws. The IF and B+ switching cables are suitably connected under the chassis, a few wiring changes are made, and the UHF-VHF switch is installed at the rear of the cabinet.

The drive-gear meshing of the UHF and VHF tuning units permits the set owner to adjust both units by means of the same knob.

The unfamiliar symbols shown under the words *antenna connection* (fig. 4A) represent a double-tuned coaxial line. The line is basically a quarter wave length tuned stub, shorted at one end. The inductance of this stub (as well as the stub used in the second preselector circuit) is varied by means of a ribbon that moves across it. The ribbons are attached to the dial cord and pulley and change the inductive reactance of the

(Continued on page 45)

Fig. 5—Stromberg-Carlson UHF TV Converter. Separate VHF and UHF antennas may be used.

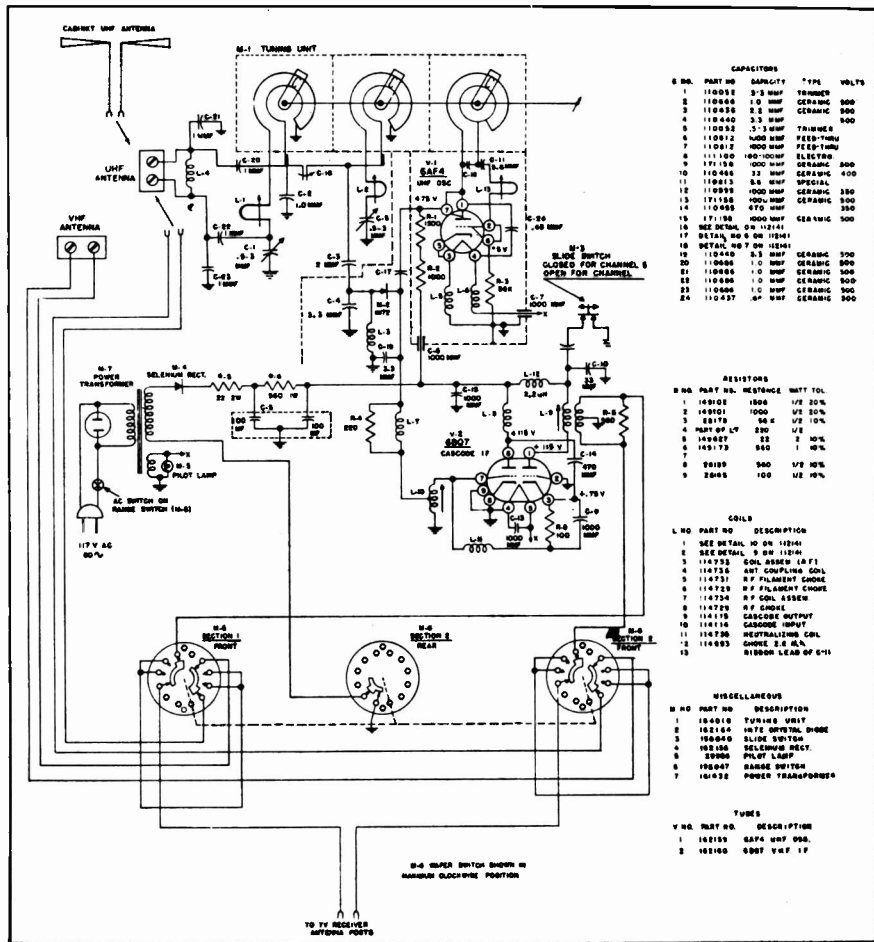

# Keyed AGC Circuits

## Shortcomings of Simple and Delayed AGC Systems; Need

By Solomon Heller  
Technical Editor  
Television Retailing

● To better understand keyed AGC, we should consider why such a system is needed—or what defects in simple and delayed AGC systems made a different form of AGC desirable.

Both simple and delayed AGC systems have relatively slow rates of response. That is, the time constant of the AGC condenser and resistor is relatively long. This is an undesirable, but unavoidable feature of these systems, as we shall soon see. Let us first review briefly why the time constant is long. Then we can consider the undesirable effects that can be attributed to this characteristic.

The AGC condenser, in simple and delayed systems, is charged by the horizontal sync pulses to approximately the peak level of these pulses. An AGC voltage is consequently produced that remains unchanged as long as the video carrier and horizontal sync pulse levels remain constant. When the carrier tends to change in amplitude, the horizontal sync pulse levels change correspondingly, causing the AGC condenser's charge to rise or fall. The resultant change in the AGC voltage bucks the carrier's tendency to alter in amplitude, keeping it substantially at its former level.

### RC Time of AGC Condenser

The discharge time of the AGC condenser and resistor is relatively long with respect to the interval between horizontal sync pulses. If the time constant is made too long, the AGC system will not respond quickly enough to momentary changes in carrier amplitude brought about by fading, or slow changes in supply voltages, and these changes will therefore affect reception. If the time constant is too short, the AGC voltage will be affected by low-frequency video signals, chiefly the long-duration, low-frequency vertical sync pulses. When such signals are coming in, the AGC system will feed a small portion of them back to the controlled stages, causing the amplitude of these signals to be improperly reproduced with respect to the rest of the composite video signal. Unstable vertical synchronization, improper background shading and other troubles tend to result.

Now, although the discharge time of the AGC condenser is relatively long, its charging time is much shorter.

Short-duration incoming noise pulses are therefore enabled to charge up the fast-charging AGC condenser. These noise pulses take a much longer time to leak off (since the resistance in the discharge path of the AGC condenser is much greater than the resistance in its charge path). The charge on the AGC condenser produced by the noise pulse therefore remains for some time, and the increased AGC bias that results reduces the video detector's video and sync signal output.

The sync signals, which must be of the proper amplitude to produce good holding action even with noise absent, will be reduced in strength at a time when it is especially desirable that they be strong—i.e., in the presence of noise. An impairment of synchronization will therefore tend to occur.

The reader may inquire, why not increase the charging time of the AGC condenser and resistor and get rid of this trouble? The answer is, the charge time must not be increased very much—if it is, the AGC condenser will not charge to the peak of the sync pulse in the time allotted to it, and an accurate AGC response to changes in the strength of the incoming composite video signal will not be possible.

A small increase in charge time may be made. In some circuits, such an increase is obtained by the insertion of a

resistor in series with the cathode of the AGC rectifier (see fig. 1A). In another method used to minimize noise, a filter is inserted into the AGC network, as shown in fig. 1B.

A basic defect of simple and delayed AGC systems, then, is their susceptibility to noise. A second basic defect of these systems lies in their inability to counteract rapid changes in carrier amplitude, such as those caused by low-flying airplanes.

When an airplane cuts in between a TV transmitter and a receiver (see

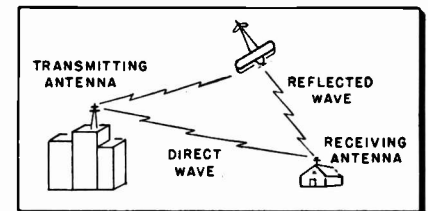

Fig. 2—Reflection of a transmitted signal from an airplane in motion may cause two signals varying in phase to be received at receiving antenna.

fig. 2), signal reflections from the airplane merge with the direct-transmitted signal. Since the airplane is in constant motion, the phase of the reflected signal is constantly changing with respect to the unreflected one. The two signals will, in consequence, sometimes aid, and at other times buck each other, in varying degrees, causing the net amplitude of the merging signals at the receiver antenna to vary from instant to instant. This flutter is too rapid in frequency to be counteracted by a slow-acting simple or delayed AGC system, and undesired symptoms, such as fluctuations in picture contrast and impairment of synchronization, therefore result.

### Action of AGC Keying Tube

An AGC circuit is evidently needed that can respond to fast changes in the amplitude of the carrier, and is not very susceptible to noise. Such characteristics are present in a keyed AGC circuit (see fig. 3).

V-305, the AGC keying tube, is cut off except when horizontal sync pulses are present at its input. Such a condition is attained by placing its plate at DC ground potential, and tying the cathode to a point about 150 V positive towards ground, making the plate negative to cathode. Horizontal flyback pulses tapped off across the width control are fed through C-428 to the plate

Fig. 1—A) Reducing noise response of AGC rectifier by inserting resistor (R-1) in charging path of AGC condenser. B) Noise reduction by means of filter.

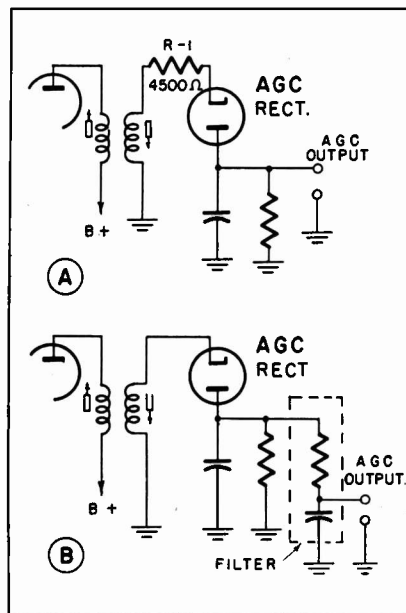

# in TV Receivers

## for Keyed AGC; How Keyed AGC Works; Analysis of Typical Circuits

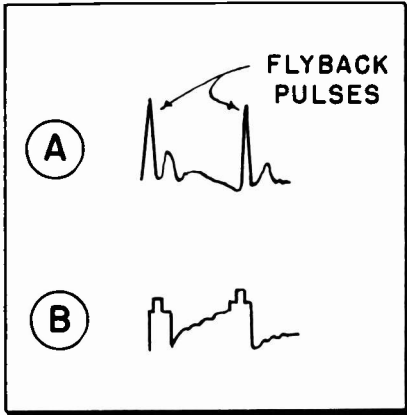

Fig. 4—A) Positive-going flyback pulses at plate of AGC tube. B) Positive-going composite video signal at grid of AGC tube.

of V-305. These pulses, which are generated by the horizontal amplifier during retrace time, are sufficiently positive to cause the instantaneous voltage present at the plate of V-305 to exceed the cathode voltage, and thus permit conduction. Conduction takes place, then, when positive-going flyback pulses are at the plate of V-305, and positive-going horizontal sync pulses are at its grid (see fig. 4).

The control grid of V-305 is biased by the flow of plate current from the video amplifier—V-306—through R-318. The bias of V-305 is close to cut-off except when the horizontal sync pulse is present. The positive-going horizontal sync pulse developed in the plate circuit of the video amplifier, and the grid circuit of V-305, decreases the bias of V-305 very considerably, assisting at the grid, the conduction that the flyback pulse is promoting at the plate. During the rest of the horizontal cycle (the interval between horizontal sync pulses), a large negative grid-bias is present that helps keep V-305 cut off.

At the control grid, or input to V-305, the composite video signal is present. No part of this signal is, however, permitted to pass through the tube and produce an AGC voltage except the horizontal sync pulse. The advantage of this arrangement lies in its exclusion of the noise associated with video signals from the AGC line.

The AGC voltage is developed by the flow of current through R-437, R-436, R-435 and R-434. Since AGC current flows only during horizontal sync pulse time, or for about 5% of the time of one horizontal cycle, the noise associated with the remaining 95% of the cycle is eliminated. The AGC system's suscepti-

bility to noise is therefore very radically reduced.

Another of the advantages of this circuit lies in its fast response. The time constant of the AGC condenser and resistor is very small—about two-thousandths of a second—which makes it possible for the AGC system to buck fast changes in carrier amplitude, such as those produced by airplane reflections.

The reason that the time constant can be made so low lies in the fact that the AGC rectifier no longer has to filter out video signals and vertical sync pulses—the rectifier does not conduct when these signals are present at its input. In simple and delayed AGC system, on the other hand, these signals are present at the output of the rectifier, and have to be filtered out by using a sufficiently large AGC condenser, which means a long AGC time constant, and a slow-acting circuit.

### Filtering the AGC Voltage

The keyed AGC circuit has to filter out only the horizontal sync pulses. For this purpose, the fast time constant present is quite suitable. The reason that the horizontal sync pulses must be filtered out (in all AGC systems) is that the AGC voltage is based on a relatively large number of horizontal sync pulses, not individual pulses themselves. If the AGC time constant was so short that individual horizontal sync pulses were able to change the AGC voltage, the latter would not be a pure DC voltage, but would contain

a horizontal sync pulse ripple. The feedback of such an improperly-filtered AGC voltage to the controlled stages would tend to impair horizontal synchronization, and introduce other troubles as well.

The use of a string of resistors, instead of one resistor, in the plate circuit of V-305 is for the sake of supplying an AGC voltage to the RF amplifier different from that applied to the controlled video IF amplifiers. Some of the resistors, in conjunction with their associated condensers, are employed to filter the flyback pulses out of the AGC line.

The composite video signal applied at the grid of the keyed AGC tube is not only positive-going—its DC level has been restored as well. All the sync pulses therefore line up at the same level, and as long as the video carrier remains constant, the AGC voltage produced by V-305 will remain the same. When the amplitude of the video carrier tends to change, the sync pulse level of the composite video signal will change with it, affecting the bias and conduction of the AGC rectifier proportionately, and causing the AGC output voltage to buck the change.

Let us say, for example, that the video carrier tends to increase. The grid signal input to V-305 will increase, the horizontal sync pulse level will rise, and V-305 will conduct more. The AGC output voltage will therefore increase, and the gain of the controlled stages will drop, tending to maintain the video carrier at its former level.

Fig. 3—Representative keyed AGC circuit, used in Admiral 24D1, 24E1, 24F1, 24G1, and 24H1

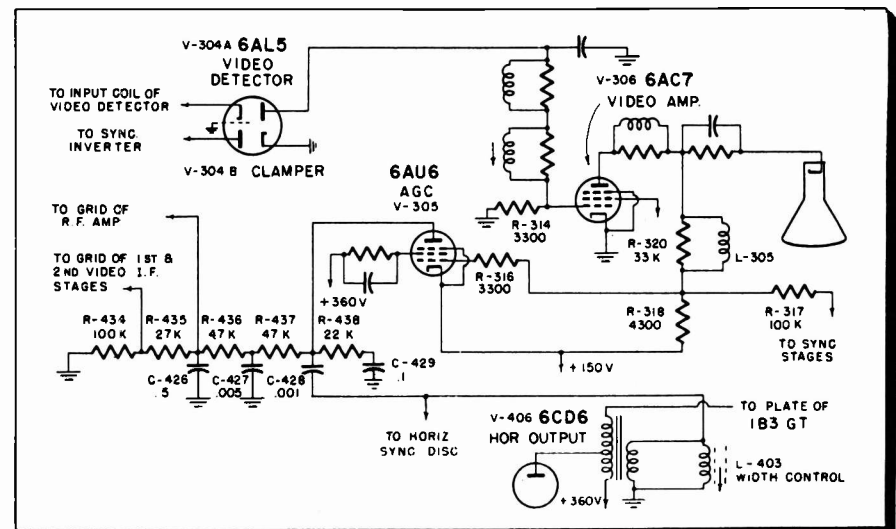

# Servicing Keyed AGC

## Representative Troubles in Typical Circuits.

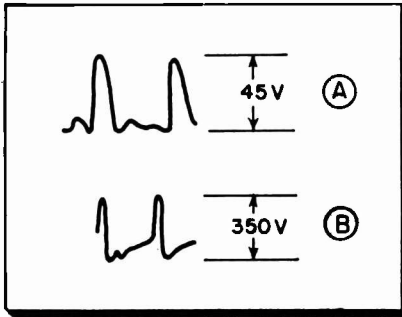

Fig. 2. (A) Hor sync waveform at AGC tube grid. (B) Flyback waveform, AGC tube plate.

We outlined the operation of the keyed AGC circuit shown in fig. 1.

Troubleshooting in this circuit will be facilitated if a scope is available. When the circuit is operating normally, the composite video signal will be seen at the grid of V-305. If the scope frequency setting is advanced to fifteen or thirty thousand cycles, horizontal sync pulses should be observed (see fig. 2A). Their normal peak-to-peak amplitude in this circuit is 45 V.

A 350 V peak-to-peak flyback pulse waveform resembling the one shown in fig. 2B should be seen on the scope screen when the scope leads are connected between the plate of the AGC keyer and ground.

Defects in the AGC circuit, or in other circuits that affect the AGC circuit, can kill both picture and sound. A defective video amplifier, for example, can eliminate the sound signal. With the video amplifier operating normally, its plate current produces a voltage drop across R-318 (as well as other resistors in series with R-318) that makes the grid of the AGC tube 130 V positive to ground. The cathode of the AGC tube is 150 V positive to ground. The bias of V-305 is therefore -20 V.

If the video amplifier becomes inoper-

ative, and its plate current stops flowing, it will no longer produce a voltage drop across R-318. The upper end of R-318 will therefore be as positive as its lower end, instead of being less positive, as it is under normal conditions. The grid voltage of V-305 will therefore also be more positive. The excessive conduction of V-305 that results will produce an excessive AGC voltage that will cut off the RF amplifier as well as the controlled video IF stages.

Since the sound signal is taken off at the plate of the 2nd video IF amplifier, it will be more readily eliminated by a rise in AGC voltage than if it were removed at the mixer plate. The picture will also be killed, when the sound is cut off.

Faced by such symptoms, in a receiver of this type, the alert serviceman will try substituting a new video amplifier, as well as front-end and 1st video IF tubes, before he starts more elaborate circuit tests.

If the AGC circuit becomes completely inoperative (due, say, to a defective AGC tube) the sound volume will increase, while the picture disappears. This rather surprising circuit characteristic may be analyzed as follows:

Video amplifier V-306 is direct-coupled to video detector V-304A. The grid return resistor of V-306 is R-314. R-314 is also the load resistor for V-304. Therefore the bias of video amplifier V-306 is determined by the voltage de-

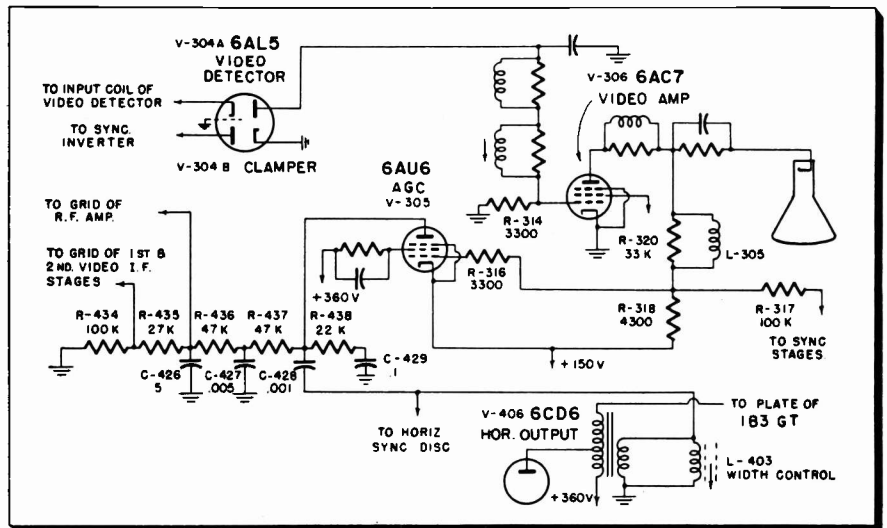
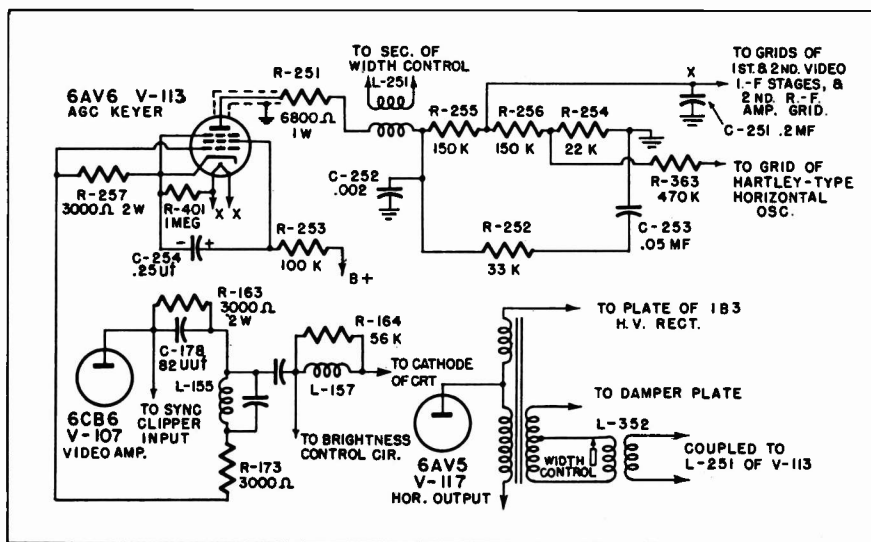

Fig. 1. (above) Representative keyed AGC circuit, used in Admiral 24D1, 24E1, 24F1, 24G1 and 24H1. Fig. 3. (below) Keyed AGC circuit used in GE Models 17C110 and 17C111.

veloped across R-314. This voltage depends on the current through R-314, which in turn, depends on the signal input to the video detector. If the signal input to V-304 becomes excessive—as it will when the AGC bias is lost—the video amplifier bias developed across R-314 may become so negative that V-306 is cut off, killing the picture.

At the same time, the loss of AGC bias in the RF amplifier and 1st video IF stages will increase the sound signal level. Therefore, if the sound volume seems above normal, and the picture is absent, a quick replacement of the AGC tube would seem the best-advised servicing procedure, when a receiver containing the circuit described is encountered.

In fig. 3, the keyed AGC circuit used in GE models 17C110 and 17C111 is shown. The flyback pulse is coupled to the AGC keyer through a transformer, instead of a condenser, as in the previous circuit. The grid of the Hartley-type oscillator employed to generate the horizontal deflection voltage is attached through R-363 to the AGC line. This



# Circuits in TV Sets

Symptoms They Produce. Trouble-shooting Procedures.

connection is probably made to stabilize the AGC circuit action.

C-252, R-252 and C-253 filter out the flyback pulses from the AGC line. The plate lead of V-113 is shielded, probably to prevent induction of the high-amplitude flyback pulse into nearby circuits. In other respects, the circuit is similar to the preceding one.

To check whether the AGC circuit is operating, V-113's grid may be shorted to cathode, and the AGC bias produced between point X and ground measured. This bias should be -30 V or more. If it is, the keyer and horizontal deflection system are probably working OK.

The grid is shorted to eliminate the video signal input applied to the keyer. The possibility of trouble in the stages preceding the keyer is thus isolated. If the AGC voltage measured with the grid shorted to cathode is normal, but is not normal when the grid is unshorted, trouble in the video amplifier or some stage preceding it is indicated. Trouble in the grid circuit of the keyer is also a possibility.

When the AGC circuit is inoperative, negative pictures are likely to result, due to the overloading of various receiver stages. One of the more obscure things to check for in such a case is a defect in the width control. When the flyback pulses at the plate of the keyer are missing, or have insufficient amplitude, an open, partial short or complete short may be present in either the width control, or the winding coupled to it. Resistance checks with the width control primary and secondary disconnected will verify whether any defect is present here.

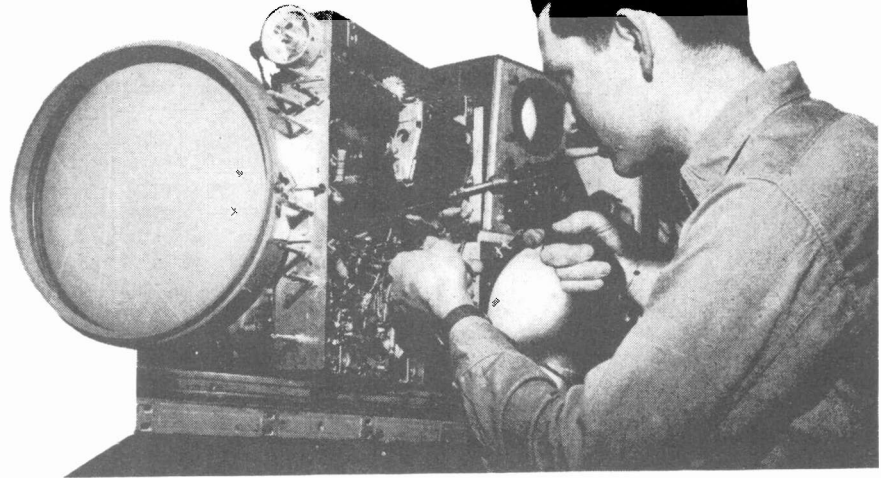

Scope tests at different points in the AGC line will reveal the trouble when flyback pulses are not being filtered out of the AGC feed-line. The 15,750-cycle pulses will be measurably apparent on the scope screen in such a case, instead of being absent.

Other defects, foreign to simple and delayed AGC circuits, but quite chummy with the keyed AGC network we have been describing, may be cited.

Distorted picture and sound, due to damping tube trouble is one of them. The AGC tube's AC plate voltage is taken off across the width control, which is in the damper circuit. If the damper tube becomes gassy, the irregular, highly non-linear conduction that it produces will change the voltage waveform appearing across the width control. Since this voltage is fed to the AGC tube's plate, the AC plate voltage of V-305 will be incorrectly shaped,

constantly changing at an irregular rate, and incorrect in amplitude. The AGC-controlled stages will therefore be fed an improper control voltage, possibly causing distortion in both picture and sound.

Proper operation of the keyed AGC circuit requires that the horizontal sweep be in synchronism with the incoming composite video signal. Under such conditions, the flyback pulse appears at the plate of V-305 at the same time that the horizontal sync pulse appears at the grid, and conduction for a very short interval, within fairly precise time limits, results.

When the horizontal sweep is not in synchronism with the incoming signal, however, plate and grid pulses on V-305 will no longer be in step, and the AGC tube may conduct at times other than the correct intervals, causing the AGC bias to vary rapidly, instead of remaining stable.

Improper AGC bias can therefore be the result of a fault in the horizontal deflection system of the receiver, particularly the horizontal AFC circuits. The obvious conclusion is, make sure that horizontal synchronization is ok, before trouble-shooting the AGC circuit proper. Say for instance that the sound signal is imperfect, and horizontal synchronization is also poor. Knowing the circuit, the serviceman would correct the horizontal sync trouble before he works on the sound symptom, because he knows that the sync trouble can be the daddy of the sound defect, via the AGC system.

A third keyed AGC circuit is shown in fig. 4. In this circuit, delayed and keyed AGC features are combined. The AGC amplifier is highly biased in the presence of weak incoming signals, and is practically cut off, in spite of the flyback pulses at the plate. The only negative AGC bias developed is due to the conduction of V-105B, the delay tube. The plate of this tube is fed to a posi-

(Continued on page 46)

Fig. 4. Keyed AGC circuit used in Crosley Models 511-447MU, 5L-459MU, CH321-4.

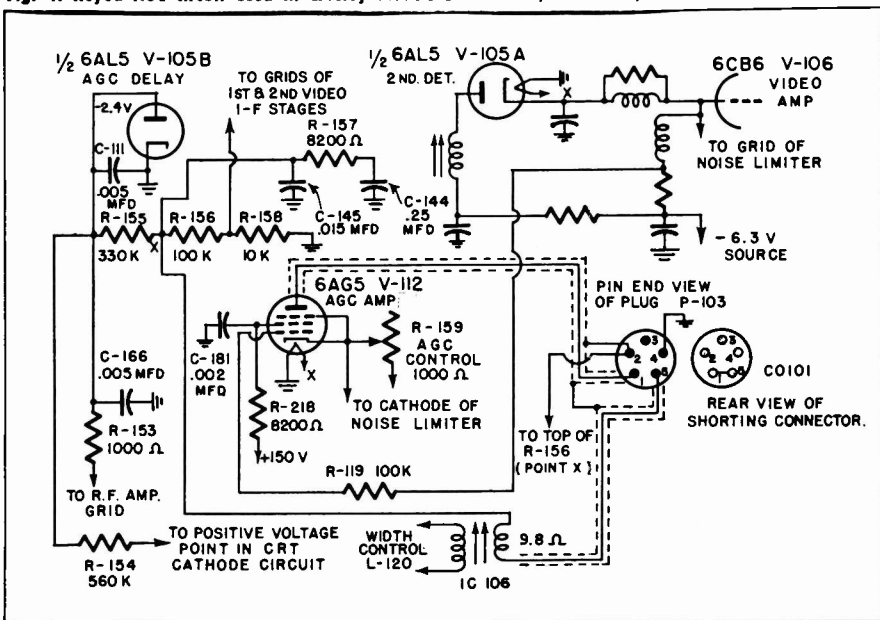

# Cascode Amplifiers

## Development of the Low-Noise, High-Gain Circuit. Triodes vs Pentodes in

• The cascode amplifier is becoming a standard feature of VHF and UHF television tuners. This circuit is a series-arrangement of two triodes, the first of which is operated as a grounded-cathode RF amplifier, the second as a grounded-grid RF amplifier. Readers who do not "dig" these terms will be supplied with an electronic pick and shovel later on in this article. An understanding of the operation of cascode tuners is essential to the technician, since he may have to service them. Your editor has not yet seen a clear and thorough analysis, from the serviceman's point of view, of how a cascode amplifier works. This article will provide, or attempt to provide, such an analysis.

Before we wade into the swamps of cascode theory, we should inspect our maps—i.e., review some preliminary considerations. One of the basic demands made of children and RF amplifiers is that they introduce as little noise as possible. The reason for this (in the case of RF amplifiers) is that the signal/noise ratio of the TV receiver is established primarily in the first tube. The minimum signal that the TV receiver can do business with depends on the amount of noise introduced in this stage. The larger the noise level here, the greater must be the signal amplitude to override it. Improving the signal/noise ratio—i.e., minimizing the noise introduced in the first tube—is therefore as advantageous

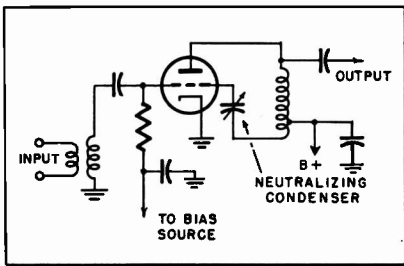

Fig. 1—Grounded-cathode RF amplifier. In some cases, a cathode bias resistor and bypass condenser are also present.

as increasing the power output of the TV transmitter, and far less expensive—at least to the transmitter people.

From the standpoint of minimizing noise, use of a triode as an RF amplifier would seem preferable to the employment of a pentode. This is true because the random division of cathode current in a pentode between plate and screen produces a shot-noise effect about three to five times greater than it would be if the screen were attached to the plate, and the tube functioned as a triode. This undesired noise is called *partition noise*.

Now triodes, although they have the virtues of introducing little noise compared to pentodes, tend to be unstable when used as high-frequency amplifiers. This is due to the large amount of feedback between plate and grid in these tubes. Some form of neutralization is therefore required when a triode is used in a conventional circuit as an RF amplifier, to prevent oscillation. Even with neutralization, how-

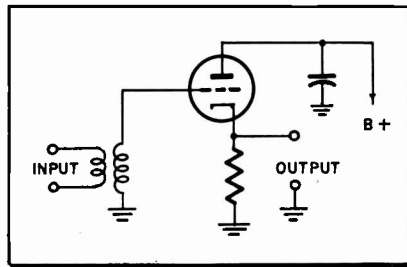

Fig. 2—Grounded-plate, or cathode-follower circuit. Gain of the stage is close to 1, except where the cathode or load resistor is very low (considerably less than 4000 ohms), in which case the gain drops substantially below 1.

ever, triodes tend to be unstable, and this fact limited their use in TV tuners (prior to the introduction of the cascode amplifier). Pentodes were most often used instead, because they were more stable, particularly in tuned input circuits, and did not require neutralization (the shielding effect of the screen grid in a pentode reduces the plate-to-grid capacitance very greatly).

Midnight oil—or the daytime equivalent thereof—continued to be expended by engineers on the problem of getting a triode to behave better. To more readily understand how the triode was finally made acceptable to the polite society of the TV front end, we should review the different ways in which a triode can be used for RF amplification.

A triode can be employed in one of the following 3 ways as an RF amplifier: 1—grounded-cathode amplifier. 2—grounded-plate stage. 3—grounded-grid amplifier. For any given tube, approximately the same noise factor will be introduced in all three set-ups.

The grounded-cathode circuit (fig. 1) derives its name from the fact that cathode of the tube is at AC ground potential (by connection direct to chassis, or through a cathode bypass condenser to chassis). This circuit can brag of high gain. When it is used as the second of two RF amplifiers, it doesn't load the first one down, (except under special circumstances) because its input impedance is high. However, its requirement of a neutralization ad-

justment which generally turns out to be critical and unstable in conventional high-frequency circuits has kept it sitting on the bench.

The grounded-plate amplifier (fig. 2) is a cathode-follower circuit. Its maximum gain is 1, so it has about as much right to be called an amplifier as a janitor has to be called an engineer. Since this circuit usually introduces a loss, rather than a gain, it is only useful in special applications where gain is not vital. It can be included out, as the saying goes, as far as RF amplification is concerned.

In the grounded-grid amplifier (fig. 3) the grounded grid shields the plate from the cathode in just the same fashion that the screen grid of a pentode shields the plate from the control grid. A triode set up in this way will operate without going into oscillation, since the input and output circuits are effectively isolated from each other. A disadvantage of the grounded-grid system, if it is used by itself for RF amplification, lies in the fact that the AC plate current of the tube flows through the source of the input signal, loading down the source and reducing

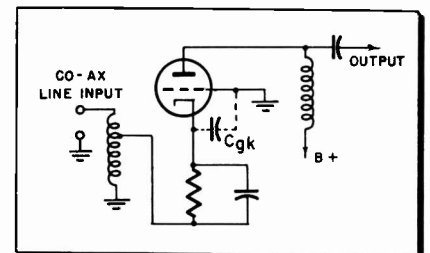

Fig. 3—Grounded-grid amplifier. The cathode-to-grid capacitance ( $C_{gk}$ ) shunts the input circuit. The input impedance (across the input terminals) is very low in this circuit.

the gain. Another disadvantage is that the very low input impedance varies inversely as the transconductance of the tube. When the transconductance changes—due, say, to a variation in the AGC bias applied to the RF amplifier—the input impedance changes with it; the matching of this impedance to the transmission line and antenna is therefore upset, tending to cause reflections and loss of signal.

Now that the subject of triode amplifier set-ups has been reviewed, we can go on to the cascode amplifier. The cascode amplifier (fig. 4) consists of two triodes which, in combination, provide the amplification of a single pentode; the stability of a pentode; and the low noise factor of the first triode. Quite a package, especially as the two triodes may be provided by a single dual-triode tube. Reception in fringe

# in TV Front Ends

## RF Stages. Grounded-Cathode, Grounded-Grid and Grounded-Plate Circuits

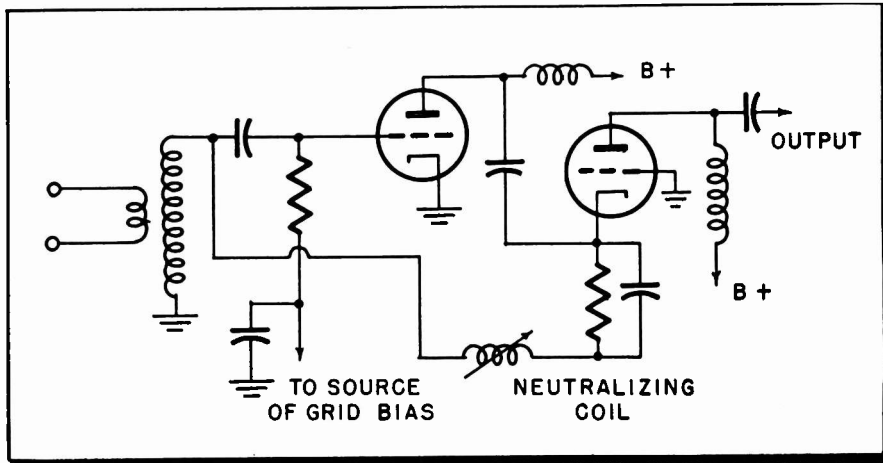

Fig. 4—An early non-commercial cascode amplifier (used in an experimental tuner).

areas can be considerably improved by the use of a cascode RF amplifier.

The second stage of the cascode amplifier is a triode like the first, because the signal/noise ratio is, to an appreciable extent, affected by the noise generated in the second stage of the receiver; it is therefore desirable to make the noise level in this stage as low as possible.

Two triodes can be connected in cascode in any of nine possible ways. The set-up shown in fig. 4 was chosen, because it provided optimum noise factor, stability and gain. The reader will probably recognize that the system comprises a grounded-cathode triode followed by a grounded-grid triode.

Neutralization of the first triode is effected by feeding an out-of-phase signal from the cathode circuit of the second tube to the grid of the first tube, through a neutralizing coil. The grounded-grid second triode requires no neutralization.

The heavy loading of the first triode by the second one (due to the connection of the first triode's plate circuit across the second triode's low-impedance cathode circuit) reduces the first one's gain to a point where feedback dangers are reduced; use of a neutralizing coil further helps to eliminate the possibility of feedback. Thus a grounded-cathode triode with a fairly good gain can be used for RF amplification—something which couldn't be done when the grounded-cathode triode performed in a solo role. The second triode not only keeps the first one behaving like a lady—it also contributes to the gain of the system.

The circuit shown is an early one, and could not be used in commercial TV tuners, because it would have required the switching in of a different neutralizing coil for each channel (due to the frequency-sensitive characteristic of this coil). A later version of the

cascode tuner is the *direct-coupled driven grounded-grid circuit*, illustrated in fig. 5. This cascode amplifier circuit is used in the front ends of "21" series Admiral receivers and other late model sets.

This circuit provides a number of advantages. First, the direct-coupling (signal current of the first tube flows through the second tube as well) permits several coupling network components to be eliminated. The distributed capacitance to ground at the output of the first triode, and the input to the second one is thus reduced, increasing the gain of the system at the lower channels. (The circuit capacitance can be tuned by means of a series coil to increase the gain on the higher channels.) Second, direct-coupling, by extending the cut-off of the character-

istic curve, reduces the danger of cross-modulation by around 800%. AGC bias is applied to the first triode to also help avoid cross-modulation. This fuss over cross-modulation is made because a sharp cut-off tube, instead of a remote cut-off one is used, and such a tube is apt to be as chummy with cross-modulation as a chassis is with its cabinet. (A remote cut-off tube isn't employed to avoid the problem because the signal/noise ratio obtained with it would be lower than with a sharp cut-off tube.)

The double-triode used in the cascode amplifier circuit is generally a 6BQ7 or 6BK7. This new tube type has a very high transconductance, which provides a good signal/noise ratio. Its input conductance—which depends primarily on its input capacitance—is very low, resulting in a relatively small shunting of the antenna. A good voltage gain in the antenna input circuit is thus obtained.

The damping resistor in shunt with the grid coil of the first triode prevents excessive changes in bandwidth and input impedance that would tend to result from variations in AGC bias. The resistor also keeps the termination of the transmission line fairly constant from channel to channel, preventing the setting up of standing waves in the line. L101B, the antenna coil secondary, resonates with the inter-electrode and stray capacitance of the first triode's input circuit, in series with C102, a variable trimmer. AGC bias is applied through a resistor which, in conjunction with C115, acts as a

(Continued on page 47)

Fig. 5—Cascode tuner used in Admiral 21W1 and 21Y1 chassis. A shield is present between the two sections of the tube. Voltages indicated are measured with the 6BK7-Q7 tube removed from its socket. In the most recent version of this circuit, the bias network ratio of the grounded-grid stage has been changed to further remote the tube cutoff, and the grounded-grid (as well as the grounded-cathode) stage has been capacitatively neutralized.

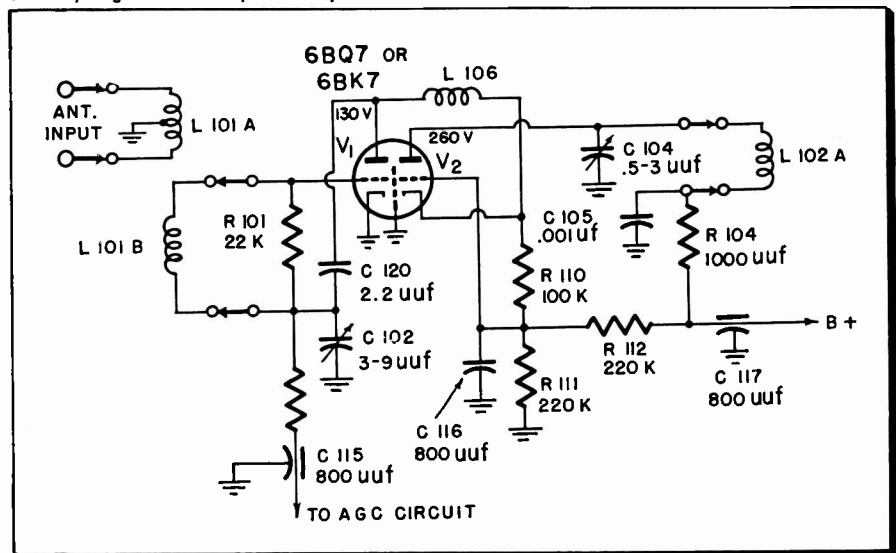

# Troubleshooting Hints On

Case Histories from the Service Bench on Difficult or Unusual Set Failures

## Locating Short in Auto Radio Power Supply

The fuse in a battery eliminator blew when an auto receiver was connected to it. Since fuse-blowing was not the complaint cited by the set owner, another fuse was inserted, and the set was tried out once more. The second fuse promptly joined its buddy.

The battery eliminator was checked while disconnected from the set (after a third fuse had been inserted in it). Its terminal voltage was correct.

The resistance of the set's "A" power supply wire (see fig. 1) to ground was then checked. The reading was  $\frac{1}{2}$  ohm. This seemed too low.

All the tubes were removed from their sockets. The pilot light was taken out of its holder; and the speaker field leads disconnected from the 6 V DC feed line. The resistance reading now measured between the "A" wire and ground was 18 ohms, which seemed a reasonable total for the chokes and coils remaining in the circuit.

The tubes were then replaced one at a time, with the ohmmeter left connected between the "A" lead and ground. The resistance reading dropped as each tube was inserted, but reasonably so. Ditto for the insertion of the pilot light. When the speaker field "hot" wire was re-connected, however, the resistance measured by the meter dropped sharply to  $\frac{1}{2}$  ohm.

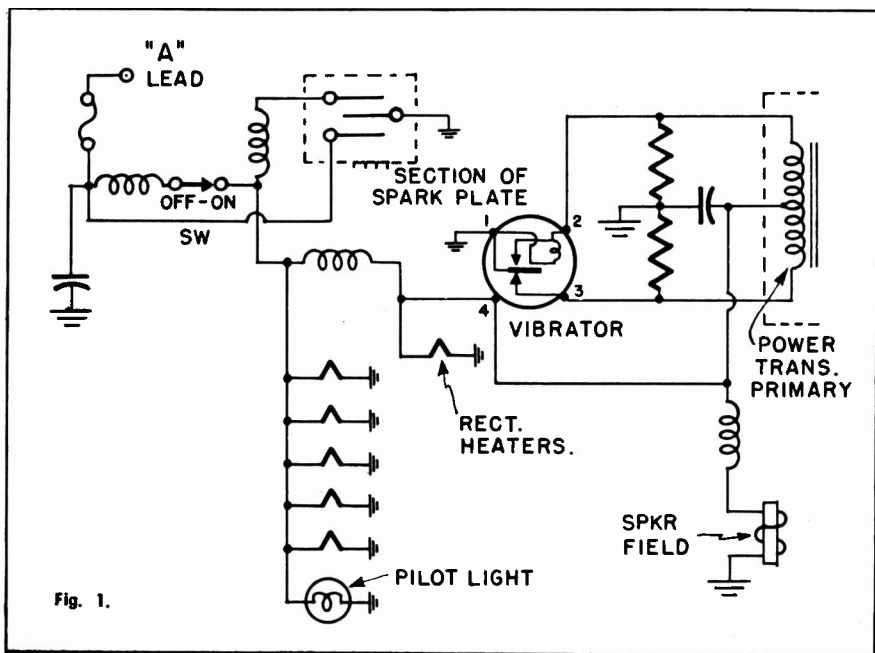

Fig. 1.

A visual inspection of the lead showed it was shorted to ground at the point of its origin—i.e., the tube socket terminal to which it was connected. The short was possibly due to excessive strain on the wire, when the speaker assembly was removed from the receiver case.

Removal of the short restored the set to its original state of disrepair. Location of an intermittent tube a short time later brought the receiver to normal operation.

## Clicking Noises on GE Model 51 5F

Clicking sounds were audible in this radio receiver from time to time. A loose socket connection was suspected, for this reason: Removing a tube from its socket and reinserting it again quickly, causes a click to be heard. Conversely, when a click is heard, isn't it likely that a tube is being, in effect, removed and reinserted into its socket, due to a loose connection?

Conventional tube-wiggling tests did not help in localizing the trouble. Tape was wound over a pair of long-nose pliers to insulate them, and various wires and components on the different sockets were then tugged at. When one particular component lead was tugged, a click resulted.

Special-type sockets are used in this GE set, with component connections brought to special connectors above the

chassis, and a socket cover mounted over these connectors. The cover on this one suspect socket unit was removed by bending in two lugs which held it in position. A connection that looked as if it might be cold-jointed was noticeable. It was carefully resoldered. No further clicks were heard.

## Using 1,000-Ohm-Per-Volt Meter

High-resistance and vacuum-tube type voltmeters are widely used in servicing TV and FM receivers, and necessarily so. What about the orphaned

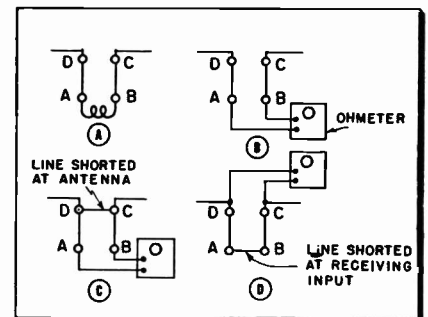

Fig. 2—Using 1000-ohm-per-volt voltohmmeter to check antenna system. a) Normal connection of antenna and line to receiver input. b) Receiver input disconnected. Checking line for short-circuit. c) Checking line for open-circuit. d) Checking line for open with ohmmeter attached at antenna side of the line.

1000-per-volt voltohmmeter, though—can't it be used for anything in TV servicing?

An excellent use for it is in checking antenna systems. It is small enough to be highly portable, and needs no power, like a VTVM. It can be used just as well on a roof, as in a house, to check for an open or short in a transmission line (see fig. 2).

## Providing Elbow Room in the TV Front End

When trying to get into the front end of a TV receiver, to make resistance or voltage checks, or perform some repair, look for a removable plate on the chassis near the front end, before you try to disassemble the latter. Some receivers have such a plate. When it has been unscrewed and swung aside, components in the front-end section become more accessible.

In cases where a turret-type tuner is present, removal of a suitable number of strips will make almost any front-end unit easy to get at.



# TV / Radio Sets

Show the Way to Speedier Repair Work

## Brightness Control Trouble

The picture illumination could not be reduced to zero by manipulating the brightness control, on this Regal TV receiver employing a 630 chassis. Similarly, with the contrast setting at minimum, the raster could not be darkened by turning the brightness down. The picture looked out of focus. It couldn't be made sharp by adjusting the focus control.

Trouble in the brightness control circuit was suspected. To localize it, the CRT was disconnected from its socket, and the voltages from CRT cathode connection to ground, and grid connection to ground, were measured at the socket.

The cathode-to-ground voltage was zero. The grid-to-ground voltage was about +10 V. Rotation of the brilliance control while the voltages were being measured didn't appreciably change these readings. A positive grid bias of 10 V was thus present at all brightness control settings. Normally, the bias should go from a negative maximum of 40, 50 or possibly even 100 V, to 0 V, or a very small positive voltage.

A leaky coupling condenser going to the grid of the CRT was suspected. C-141 in fig. 3 was checked, but showed no signs of a leak. C-142, the condenser in the input to the DC restorer was then checked, since it could also be causing the symptoms present. This condenser showed a 200-megohm leak when resistance-checked while cold. With C-142 disconnected (at its "cold" side), the voltage measured from its open side to ground read only  $+1/2$  V; when C-142 was connected across its source of voltage, however, its leakage current increased, and it transferred a much more positive voltage to the grid of the CRT.

Set operation was restored to normal when C-142 was replaced.

## Shocking News

Servicemen who don't judge books by their covers, should not gauge an insulation merely by its thickness. Thickly-insulated wires are sometimes judged to be capable of talking back to high voltage, and used as emergency HV connectors. When the serviceman touches the outside of the wire—intentionally or inadvertently—is he surprised!

There was a case where a long, thick wire was carelessly placed on a shelf overhanging the work-bench. One (insulated) end of the wire came into contact with "hot" surface of a metal-

type cathode-ray tube. The other (insulated) end brushed lovingly against the serviceman's ear. The serviceman's remarks on that occasion were quite interesting, especially as he had one hand on the chassis, and had never been properly introduced to 15 KV before.

## Arcing OZ4

The B+ voltage in an auto radio was normal for a while, then dropped down to a very low value. No short-circuits could be found by resistance checks.

A new metal OZ4 was substituted. The same symptoms appeared. Furthermore, the new tube's emission read very low on the tube tester, after it had been in the set a short time.

A glass OZ4 was substituted for the metal one, so the insides of the tube could be watched, and power was applied for a very short time. When arcing was noted, power was immediately turned off. By arcing, we mean that

the gas glow in the tube was unusually bright, and the area of glow was irregularly shaped.

It was reasoned that the tube might be conducting in both directions, instead of in one direction alone, due to excessive inverse voltage. An opening in one of the buffer condensers was the logical fault to suspect, since such an opening would greatly increase the inverse voltage peaks between plate and cathode of the rectifier. The two buffer condensers present were therefore replaced by new, identical units. No symptoms were present after this.

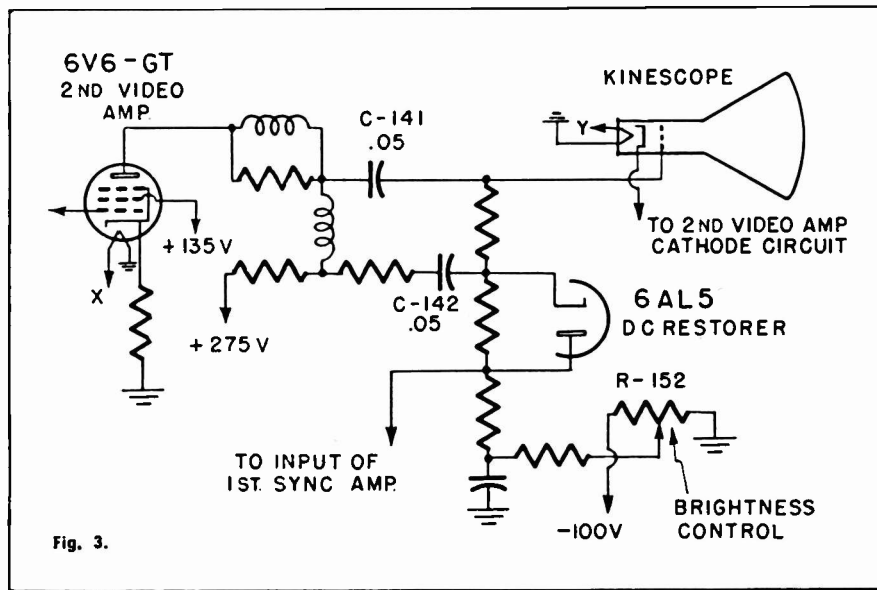

# Noise-Elimination Circuits

## General Theory of Noise Inverters. Inverter Circuit

By Solomon Heller  
Technical Editor  
Television Retailing

This article is based on data supplied by J. M. Miller, Jr., chief engineer, Bendix Radio, Division of Bendix Aviation Corp. The noise inverter circuit described in the article was developed by G. L. Haugen in the Bendix laboratory.

• Difficulties of maintaining synchronization in the presence of noise pulses—particularly when the incoming signal is weak—have led to the introduction of special noise-reducing circuits. These have been variously referred to as noise cancellers, noise inverters, etc. Their function is to improve the signal-noise ratio for vertical and horizontal sync signals. We are going to analyze a representative group of such circuits in this series of articles.

The noise inverter used in the new Bendix T14 chassis is shown in fig. 1. Before we analyze it in detail a brief consideration of the theory of noise inverters may prove helpful.

Noise is undesired in sync circuits because it will, when its amplitude is large with respect to the sync pulses, tend to produce incorrect triggering of the deflection oscillators. Now, it has been found that heavy impulse noise does not impair the operation of conventional sync circuits as long as the noise is inverted in polarity. If noise associated with, and appreciably larger than, the sync pulses is separated from the latter and turned upside down, it will be negative-going, when the sync pulses are positive-going. Such noise pulses will, in consequence, be made different from the sync pulses in one very im-

portant respect—polarity. They will therefore no longer be able to bamboozle the sync circuits into treating them as sync pulses. A noise inverter performs such an inverting (as well as amplifying) operation on noise pulses.

In a simple clipper circuit, excessively large noise pulses are merely limited in amplitude to the level of the sync tips (see fig. 2). Noise left after clipper action will still have the same polarity and amplitude as the sync pulses, and may therefore produce incorrect deflection oscillator triggering. In this respect, a noise inverter circuit is superior to a conventional noise-clipping circuit. It should be noted that noise inverters (as well as conventional clippers) have no effect, unfortunately, on noise that is smaller in amplitude than the sync tip level.

The noise pulses to be inverted should have a source which does not limit their amplitude, since they must be large enough, when they reach the sync separator input, to more than cancel their oppositely-polarized replicas that are present there (see figs. 3, 4). (This fact also explains the need for amplification in the noise-inverting circuit). It is also desirable that the sync signals come from a source which does limit in the vicinity of the sync-tip level, to obtain the benefits of the noise reduction inherent in such limiting. It is therefore customary in most noise inverter circuits to use the video detector as a signal source for the noise inverter.

There is an important disadvantage to connecting the noise inverter into the video detector output circuit,

namely, additional capacitance is unavoidably introduced here, tending to impair the receiver's gain and high-frequency response. This disadvantage is overcome in the Bendix circuit by using the (unbypassed) screen grid of the video amplifier (instead of the video detector output circuit) as the signal source.

The inverted noise is fed to the sync separator only, since it would be undesirable to have it reach the picture tube, where it would appear as white noise, instead of the more usual and less conspicuous black noise.

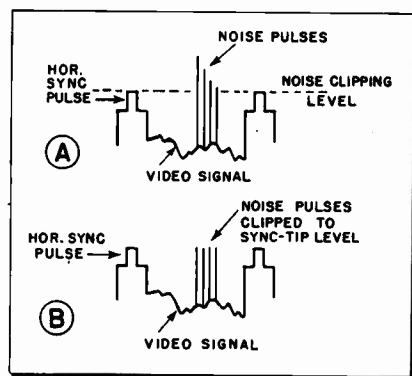

Fig. 2—Effect of simple clipper circuit on excessively large noise pulses.

Let's consider the action of the Bendix T14 noise inverter in detail. The inverter consists of a hi-mu twin triode and its associated circuit (fig. 1). Most of the screen-grid current of video amplifier V13 flows through V14A to the 155 V B+ point (for reasons to be explained soon). A much smaller part of the screen current flows through R65, which is in parallel with V14A. The impedance of V14A in parallel with R65 is very low. Consequently, the voltage changes across this impedance will be very small, when screen current variations due to signal changes occur. No screen bypass condenser is therefore needed; such a condenser is required only when the presence of a large screen dropping resistor tends to introduce substantial screen-grid voltage variations (degeneration). The incorporation of a video amplifier screen bypass condenser would, in fact, interfere with the circuit action, since it would short out or attenuate the screen signal that is fed to V14B.

The video amplifier tube is normally near cutoff on sync tips, since its control grid connects through L7 to the video detector output, and the DC negative voltage put out by the detector is maximum at sync pulse time. When a noise pulse appreciably larger than the sync tips enter the video detector, the

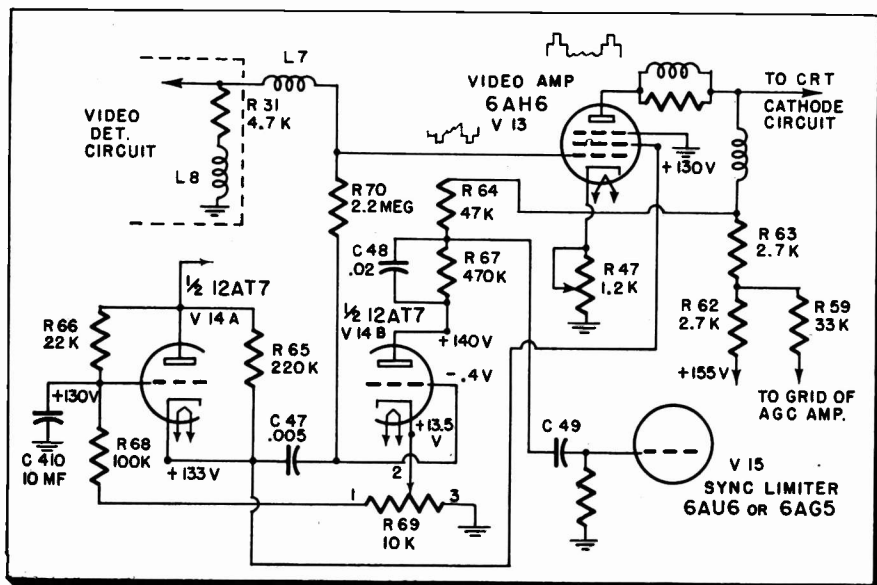

Fig. 1—Noise inverter circuit, Bendix T14 chassis. V14A and V14B comprise the noise inverter. Arrow leading from V14A plate goes to a +155 V terminal.

# in the TV Sync Stages

## Used in Bendix T14 Chassis.

large resultant negative grid voltage cuts the video amplifier off.

Before we consider further what happens when the video amplifier cuts off, let's investigate some of the things that are going on while it is functioning normally. R65, the screen dropping resistor for V13 (the video amplifier) is connected in parallel with V14A, the first noise inverter triode. Since V14A normally conducts (in the absence of excessively-large noise pulses) its plate-to-cathode impedance acts like a

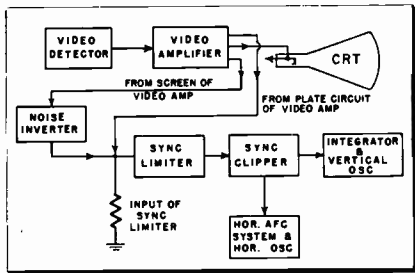

Fig. 3—Block diagram of noise inverter and associated circuits in Bendix T14 chassis.

resistor in parallel with R65. V13 thus has, in effect, two screen dropping resistors. Its screen voltage at any moment will depend on how much voltage is being dissipated across these two resistors in parallel at that moment. The greater the voltage used up across the resistors, the less will be left from the 155 V supply to feed the screen.

Now, the screen voltage constantly tends to change, since the screen is not bypassed to ground for video signals. Such (degenerative) changes would reduce the output of the video amplifier, if they were permitted to take place. They are prevented from occurring by the action of V14A.

When the video signal tends to increase the screen current and thus lower the screen voltage, the cathode voltage of V14A will be lowered the same amount, since the V14A cathode is connected to the V13 screen. When the cathode voltage of V14A drops, or goes *less positive*, it is the same as saying that the cathode is going *more negative*. V14A therefore conducts more. Its plate-to-cathode resistance *decreases* in consequence. The total resistance of V14A in parallel with R65 therefore decreases, tending to produce a lower voltage drop across the network, and thus tending to *increase* the V13 screen voltage. V14A's action thus opposes the tendency of this screen voltage to go down. A similar but reverse action occurs when the V13 screen voltage tends to go up. V14A's plate resistance increases at this time, producing a larger drop across V14A and

R65 in parallel, tending to pull the screen voltage *down*, the same amount it tended to go *up*. The video amplifier's screen voltage is thus kept substantially constant in the absence of large noise pulses. Consequently, the video and sync signals transferred to the cathode of V14A, and to the grid of V14B (through C47) have negligible amplitudes. These (positive-going) video and sync signals are not sufficiently large to drive the grid bias of V14B low enough to bring the latter out of cutoff (V14B is normally beyond cut-off because of its low plate voltage and high cathode bias).

Now, when a large noise pulse comes along, the video amplifier cuts off, and its screen (as well as plate) voltage rises to the value of the +155 V supply. V14A also cuts off at this time, since the cessation of video amplifier screen current through V14A brings the cathode and plate of V14A to the same potential, causing conduction in this tube to stop. The screen voltage of the video amplifier abruptly rises at this time from approximately 133 V to the B+ voltage of 155 V.

This sudden increase in voltage constitutes a pulse, which is developed across R65, and fed through C47 to the grid of V14B. V14B is normally so biased by the proper setting of potentiometer R69 that it is slightly beyond cutoff when the tips of the sync pulses appear at its input. In the presence of a noise pulse large enough to cut the video amplifier off, the positive voltage pulse that is produced across R65 in the manner just described, is large enough

to drive V14B into conduction.

When V14B conducts, the noise pulse present at its input is amplified and inverted. The large negative (inverted) noise pulse developed at its output (across R64) is fed through C49 to the grid of the sync separator, V15. No sync or video signals come to V15 by way of V14B—these latter signals are applied to V15 only by way of the video amplifier, through R64.

The large negative noise pulse at the V15 input cancels the positive-going but otherwise identical noise pulse that is fed to the V15 input through R64. Some negative-going noise voltage is left over, but is not harmful, since only noise of the same polarity as the sync pulses can upset the sweep oscillators.

The setting of R69 is important. If R69 is set so that the bias on V14B is too low, the inverter may respond to and invert the sync pulses, thus preventing proper synchronization and causing an erratic jumping of the picture. If the bias is made too great, the noise inverter will fail to function on noise pulses that are only moderately larger than the sync tips, permitting these pulses to get through to the sync circuits and impair synchronization. The correct setting of R69 is one where the bias of V14B is placed sufficiently beyond cutoff so that this tube does not quite invert the sync pulses when the set is operating in sync.

The problem of "lockout" must be taken into account when a noise inverter circuit is employed in a receiver using a keyed AGC system. "Lockout"

(Continued on page 48)

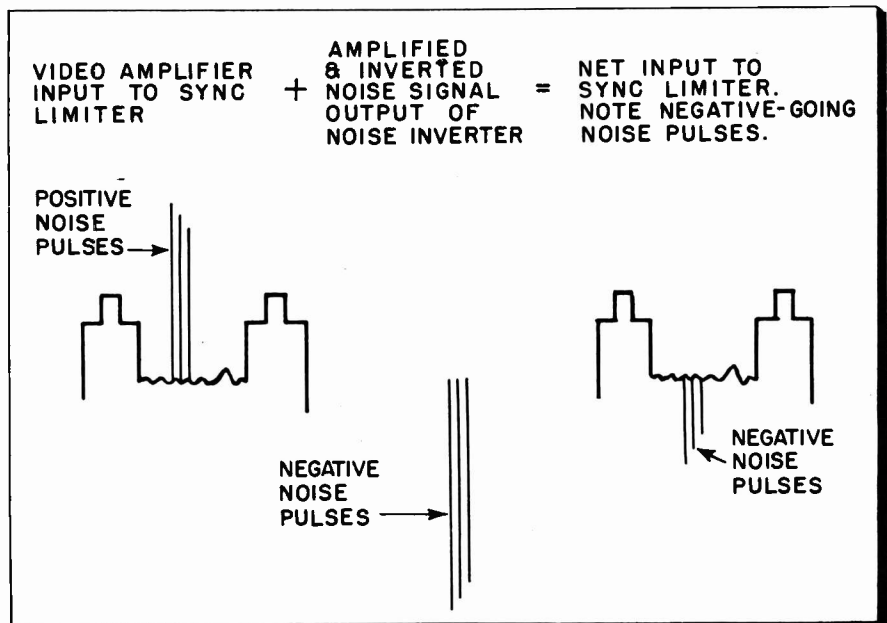

Fig. 4—Effect of mixing positive and negative noise pulses at input to sync limiter.

# Sync Noise Elimination in

## Philco TV-90 Noise Inverter

The noise inverter used in the Philco TV-90 receiver is so closely linked with the gated AGC system employed (see fig. 1), that both circuits will be described in detail.

The AGC gate tube, V13, functions like other keyed AGC tubes. A regulated source of grid bias is supplied to V13 by attaching its grid into the series-connected video amplifier—1st sound IF circuit. The composite video signal fed to the V13 grid is direct-coupled from the plate of video amplifier V7A.

video signal is also fed to the grid of the noise inverter (through C601).

The noise inverter is designed to conduct only when large noise pulses are present at its input. At other times, it is cut off. To obtain these conditions, the noise inverter is operated at a low value of plate voltage and high bias. R607 and R608 make up a voltage divider in the inverter plate circuit that reduces its plate voltage to the desired level of approximately 34V. A voltage divider in the cathode cir-

cuit—the noise inverter remains cut off (due to its low plate voltage and high bias). The composite video signal applied to its input is positive-going. Noise which can prematurely trigger the sweep oscillators is also positive-going. When video, sync and noise pulses are normal in size, they do not have the requisite amplitude to drive the grid of the inverter positive enough to produce conduction. A harmful noise pulse, however—i.e., a noise pulse whose polarity is the same as that of the sync pulses, but whose amplitude is much greater—will reduce the bias on the inverter enough to permit conduction.

When the noise inverter conducts, the noise pulse that drove it to this drastic step is amplified and inverted, and appears in the plate circuit in negative form. The noise inverter output is fed to the grid of the sync separator, where it mixes with the composite video and noise signal that is fed to this point from video amplifier V7A (See Fig. 2). The large negative-going noise signals from the inverter are more than sufficient to cancel the smaller positive-going noise signals from the video amplifier. In this way noise whose polarity is the same as that of the sync pulses is eliminated.

To prevent the noise inverter from conducting during sync pulse time (an undesired condition that would cause inverted sync pulses to be applied to the sync separator, upsetting synchronization) a circuit called a *gated leveler* is employed. The tube used—V14A—is  $\frac{1}{2}$  of a 12AU7. The circuit operation may be described as follows:

When the receiver is first turned on, there is no DC voltage present between grid and ground of the noise inverter. Video and sync signals are transferred through C601 to the grid of the in-

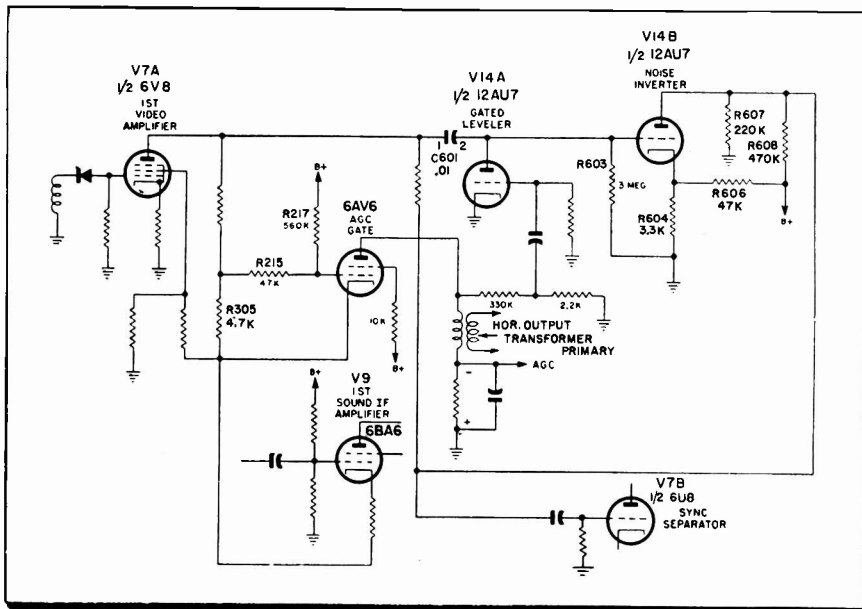

Fig. 1—Simplified schematic of noise inverter, AGC and associated circuits in Philco TV-90 chassis. Although the 6AV6 AGC gate tube is referred to as V13 throughout the article, its designation as V13 in the sketch was inadvertently omitted. (based on a Philco sketch)

A 10K resistor is connected into the screen grid circuit of V13. This resistor is protective in function. If it weren't present and the 1st sound IF tube became defective (open filament, or cathode emission failure) the bias on the AGC gate tube would be greatly reduced or eliminated, permitting it to conduct heavily. In between sync pulses, when no pulse voltage is applied to the V13 plate, excessive current would flow through the video amplifier and the screen circuit of V13. The 10K resistor limits such a current (when failure of the 1st sound IF tube tends to produce it), protecting the circuit components. In other respects, the circuit is so similar to other keyed AGC circuits we have already described that it doesn't seem to warrant further discussion.

Some composite video signal is taken off in the plate circuit of V7A and fed to V7B, the sync separator. This is  $\frac{1}{2}$  of a 6U8 tube. Composite

circuit—R606 in series with R604—places a voltage of approximately 6.6 V between cathode and ground.

When normal-sized video, sync and noise signals are present at its input,

Fig. 2—Block diagram of noise inverter, AGC and associated circuits in Philco TV-90. (based on a Philco sketch)

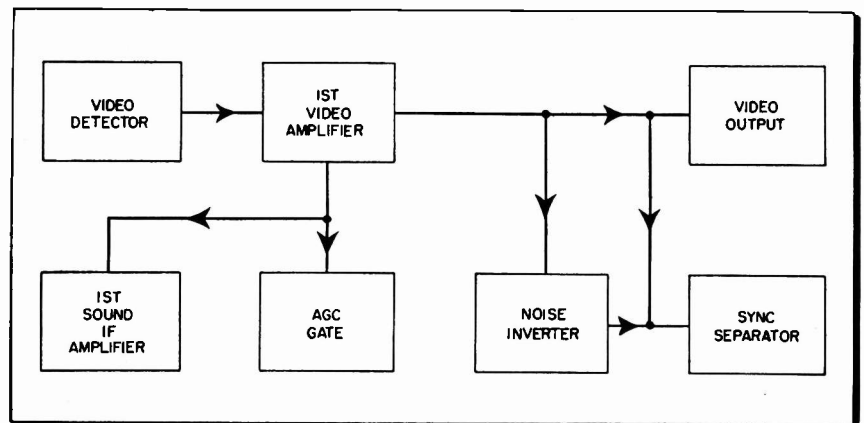

# TV Receivers

## and AGC Gate Circuits Analyzed.

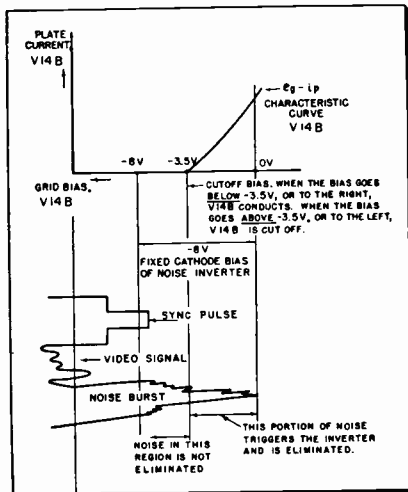

Fig. 3—Explanation by means of characteristic curve sketch of how noise several volts in excess of the sync tips triggers the noise inverter and is eliminated.

verter. These signals vary above and below the DC zero voltage level, but do not cause an appreciable DC voltage to be developed—that is, not for the first few cycles of incoming signal.

The positive swings of the incoming signal cause the plate of V14A to become positive with respect to the cathode, and conduction takes place in this tube. Electrons flow into plate 2 of C601 (and leave plate 1), charging the condenser. When the sync tip has passed, these electrons begin to leak off through R603 to ground. A negative voltage is thus developed between plate and ground of V14A. Since the cathode is grounded, the plate-to-ground voltage is the same as the cathode-to-ground voltage.

After several cycles, the charge on C601 has increased until it is approximately equal to the level of the sync pulses. The negative plate voltage of V14A is consequently much larger than the positive peaks of incoming video signals. V14A therefore cuts off in the presence of video information,

Fig. 4—Circuit conditions in the video amplifier, if the AGC gate tube was not connected into the latter's plate circuit, would permit a 15-volt separation between the sync tips and the B level. (based on a Philco sketch)

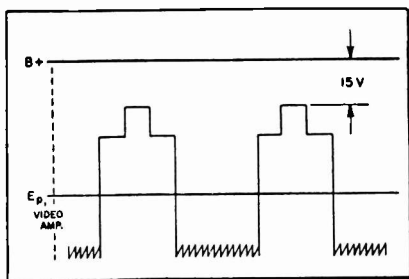

since these positive signals do not have enough amplitude to overcome V14A's negative plate voltage.

In between sync pulses, a small amount of C601's charge leaks off; the relatively long time constant of C601 and R603 does not permit much of the charge to be dissipated, so most of the V14A's negative plate voltage is retained, and the tube remains non-conducting at these times. The positive sync tips are slightly larger in amplitude than the negative plate voltage of V14A, since some of this voltage is lost through C601's discharge; conduction therefore takes place in V14A during sync-tip time, and a pulse of current flows that stops when the small charge that C601 has lost in the interval between sync tips has been replenished.

Across R603, thus, a negative voltage is continuously present; it is substan-

supplied with noise pulses of sufficiently large amplitude, since the negative noise pulse it delivers must be more than large enough to cancel its positive noise pulse counterpart at the sync separator input. A special voltage divider network has been incorporated into the grid circuit of V13, the AGC gate tube, to insure this. Before we discuss the need for this divider, and the manner in which it operates, we should first consider what would happen if it weren't present.

When the receiver is first turned on, no AGC voltage exists, since it takes a certain length of time for this voltage to develop. The above-normal receiver gain present during this interval causes an excessively large signal to be developed in the video detector output; the large negative DC voltage that is, in consequence, applied to the 1st video amplifier grid cuts the video

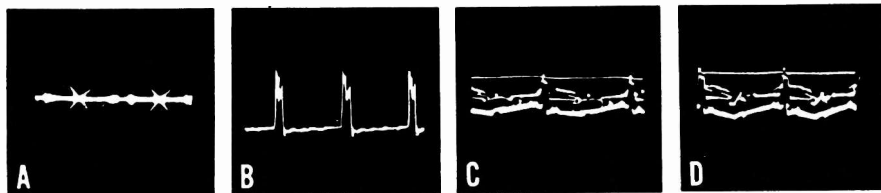

Fig. 5—Waveforms and their amplitudes in noise inverter and AGC circuits of the Philco TV-90.

A) Noise inverter cathode (pin 8). Waveshape and its amplitude vary with noise. B) Gate-pulse plug (pin 4). Waveform is 500 V peak-to-peak; frequency, 15,750 CPS. C) AGC gate grid (pin 1). 22 V peak-to-peak, 60 CPS. D) Noise inverter plate, junction of R605, C602 and C603 (fig. 6). 23 V peak-to-peak, 15,750 CPS. (courtesy Philco)

tially a DC voltage, and its amplitude is approximately equal to that of the sync tips.

Now the noise inverter tube has a fixed cathode bias of approximately 8 V. The cutoff voltage of the tube is approximately 3.5 V. This means that the tube is 4.5 V beyond cutoff. Grid signals developed across R603 must, to produce conduction, overcome the 4.5 V negative bias developed in V14B's cathode circuit, as well as the negative voltage built up in its grid circuit (across R603). Only incoming noise pulses that are a number of volts larger than the sync tips (see fig. 3) can overcome the sum of these two bias voltages. Such large noise pulses will trigger the inverter, and cause it to operate.

The question may crop up, what happens to noise pulses that are larger than the sync pulses, but not large enough to trigger the inverter? According to Philco engineers, this condition rarely occurs; even if it should, the sync separator has a certain immunity to such relatively low-amplitude noise, and therefore sync stability will not be impaired by it.

The noise inverter circuit must be

amplifier off. Plate current cessation in this tube causes its plate voltage to rise to the B level. The AGC gate tube grid, which is connected into the video amplifier plate circuit, is thus also brought to the B voltage level.

The cathode of the AGC gate tube has a fixed voltage of 125 V. This volt-

(Continued on page 46)

Fig. 6—Test points referred to in text, are shown in these portions of the actual schematic of the Philco TV-90.

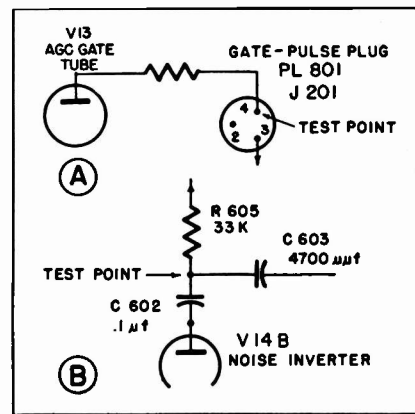

# Page from an Engineer's Notebook

## UHF-TV Frequencies & Wavelengths

Compiled by J. M. De Bell Jr., W. Budd and M. Casey, Allen B. DuMont Labs. Inc., Clifton, N. J.

Channel Number	Visual Frequency Carrier	Aural Frequency Carrier	Wavelength		Channel Number	Visual Frequency Carrier	Aural Frequency Carrier	Wavelength	
			Centimeters	Inches				Centimeters	Inches
14	471.25		63.660	25.063	49	681.25		44.037	17.337
		475.75	63.058	24.826			685.75	43.748	17.224
15	477.25		62.860	24.748	50	687.25		43.652	17.186
		481.75	62.273	24.517			691.75	43.368	17.074
16	483.25		62.079	24.441	51	693.25		43.274	17.037
		487.75	61.506	24.215			697.75	42.995	16.927
17	489.25		61.318	24.141	52	699.25		42.903	16.891
		493.75	60.759	23.921			703.75	42.629	16.783
18	495.25		60.575	23.848	53	705.25		42.538	16.747
			60.030	23.634			709.75	42.268	16.641
19	501.25		59.850	23.563	54	711.25		42.179	16.606
		505.75	59.318	23.354			715.75	41.914	16.502
20	507.25		59.142	23.284	55	717.25		41.826	16.468
		511.75	58.622	23.080			721.75	41.566	16.365
21	513.25		58.451	23.012	56	723.25		41.479	16.330
		517.75	57.943	22.812			727.75	41.223	16.230
22	519.25		57.778	22.747	57	729.25		41.138	16.196
		523.75	57.279	22.551			733.75	40.886	16.097
23	525.25		57.116	22.487	58	735.25		40.802	16.064
		529.75	56.630	22.295			739.75	40.554	15.966
24	531.25		56.471	22.233	59	741.25		40.472	15.934
		535.75	55.996	22.046			745.75	40.228	15.838
25	537.25		55.840	21.984	60	747.25		40.147	15.806
		541.75	55.376	21.802			751.75	39.907	15.711
26	543.25		55.223	21.741	61	753.25		39.827	15.680
		547.75	54.770	21.563			757.75	39.591	15.587
27	549.25		54.620	21.504	62	759.25		39.513	15.556
		553.75	54.176	21.329			763.75	39.280	15.465
28	555.25		54.030	21.272	63	765.25		39.203	15.434
		559.75	53.595	21.100			769.75	38.974	15.344
29	561.25		53.452	21.044	64	771.25		38.898	15.314
		565.75	53.027	20.877			775.75	38.672	15.225
30	567.25		52.887	20.822	65	777.25		38.598	15.196
		571.75	52.470	20.657			781.75	38.375	15.108
31	573.25		52.333	20.604	66	783.25		38.302	15.080
		577.75	51.926	20.443			787.75	38.083	14.993
32	579.25		51.791	20.390	67	789.25		38.011	14.965
		583.75	51.392	20.233			793.75	37.779	14.874
33	585.25		51.260	20.181	68	795.25		37.724	14.852
		589.75	50.869	20.027			799.75	37.512	14.769
34	591.25		50.740	19.976	69	801.25		37.441	14.741
		595.75	50.357	19.826			805.75	37.232	14.658
35	597.25		50.230	19.776	70	807.25		37.163	14.631
		601.75	49.855	19.628			811.75	36.957	14.550
36	603.25		49.731	19.579	71	813.25		36.889	14.523
		607.75	49.362	19.434			817.75	36.686	14.443
37	609.25		49.241	19.386	72	819.25		36.619	14.417
		613.75	48.880	19.244			823.75	36.419	14.338
38	615.25		48.761	19.197	73	825.25		36.353	14.312
		619.75	48.407	19.058			829.75	36.155	14.234
39	621.25		48.290	19.012	74	831.25		36.090	14.209
		625.75	47.942	18.875			835.75	35.896	14.132
40	627.25		47.828	18.830	75	837.25		35.832	14.107
		631.75	47.487	18.696			841.75	35.640	14.031
41	633.25		47.375	18.652	76	843.25		35.577	14.007
		637.75	47.040	18.520			847.75	35.388	13.932
42	639.25		46.930	18.476	77	849.25		35.325	13.907
		643.75	46.602	18.347			853.75	35.139	13.834
43	640		46.475	18.455	78	855.25		35.077	13.810
	645.25		46.494	18.305			859.75	34.894	13.738
44	651.25		46.172	18.178	79	861.25		34.833	13.714
		655.75	46.065	18.136			865.75	34.652	13.643
45	657.25		45.749	18.011	80	867.25		34.592	13.619
		661.75	45.645	17.970			871.75	34.414	13.549
46	633.25		45.334	17.848	81	873.25		34.354	13.525
		667.75	45.232	17.808			877.75	34.178	13.456
47	669.25		44.927	17.688	82	879.25		34.120	13.433
		673.75	44.826	17.648			883.75	33.946	13.365
48	675.25		44.527	17.530	83	885.25		33.889	13.342
		679.75	44.428	17.491			889.75	33.717	13.274
			44.134	17.376	900			33.333	13.123
					920			32.609	12.838
					940			31.915	12.565
					960			31.250	12.303

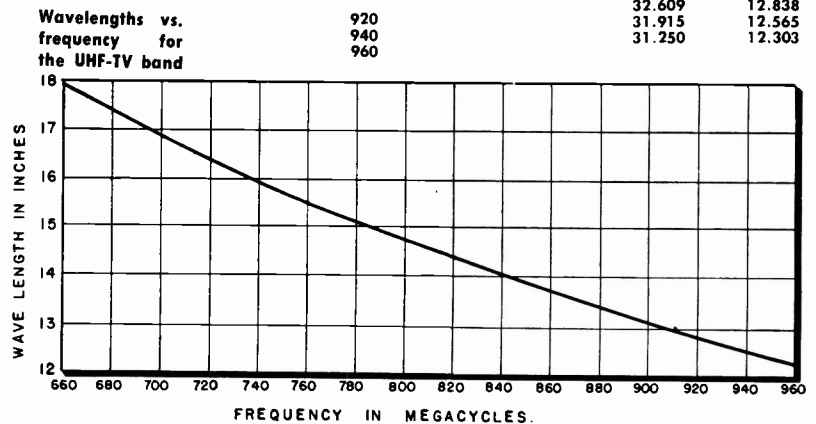
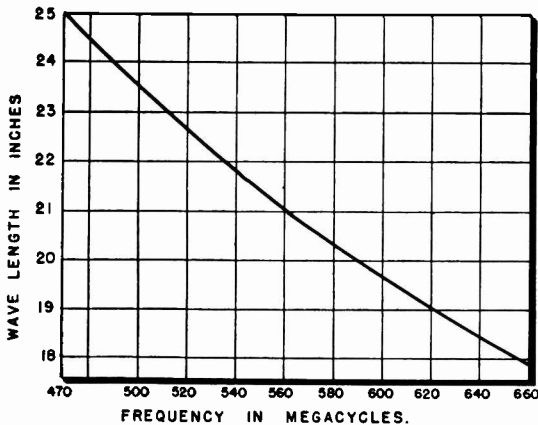

# Eidophor Projector for Theatre TV

**New system employs unique light valve principle to produce large-screen pictures approaching the quality of motion pictures**

A new system for large screen color TV projection—Eidophor—has recently been introduced in the U. S. by Twentieth Century-Fox Film Corp. Essentially of the same size and shape as conventional motion picture projectors, the device provides ample illumination to satisfy the needs of even the largest theatres. See Fig. 1.

Credit for the discovery of the novel principle used in the system belongs to Dr. Fritz Fischer of Switzerland's Federal Institute of Technology, who died suddenly in 1947. The development of the basic black-and-white system, initiated 12 years ago, has been carried out by Dr. Hugo Thiemann of the Swiss Institute and Dr. Edgar Gretener A. G. of Zurich.

Twentieth Century-Fox, which holds the world-wide rights for the manufacture and distribution of the projectors, has adapted Eidophor for color through its joint efforts with CBS. Engineering development by Twentieth Century-Fox has been under the direction of Earl I. Sponable, co-inventor of the sound-on-film process currently used throughout the motion picture industry.

## Operating Technique

Operation of the Eidophor system is illustrated in Fig. 2. Light from the arc lamp (1) passes through the aperture plate (2), color wheel (3), condenser lens (4) and strikes the mirror bar system (5). This plane mirror is tilted at 45° to the direction of this initial light beam, and has open slits between and about as wide as the parallel mirror bars. Consequently, half of the light passes through (5) and is lost, while the other half is reflected down on the spherical mirror (7). Assuming for the moment that the thin oil surface, or Eidophor liquid, covering (7) is not disturbed, the incident light on area (8) will be reflected back to the parallel mirror bars of (5) and on to (1) along the same path as the original incident beam. On the other hand, if the liquid surface is deformed by an electron beam from gun (6), the light impinging on (7) will be deflected so that the reflected beam does not strike the mirror bars

## HOW GOOD IS EIDOPHOR PICTURE QUALITY?

A recent demonstration using a 525-line raster, 8 MC bandwidth and field-sequential color projected on a 15 x 11.5 ft. screen, gave the editors of TELE-TECH the following impressions:

- Overall quality was splendid and approached that of best motion picture projection.
- Brightness was about equal to motion pictures.
- Definition was excellent.
- Color fidelity was very good, with only slight color "hangover" which would not normally be noticed by lay observers.
- Contrast ratio of 1:200 was quite adequate.

of (5) but rather passes through the slits and then through the projected lens (10), to the directing mirror (11), onto the theatre screen (12).

Definition is determined by the number of mirror bars, which project parallel lines of light on area

(Continued on page 45)

Fig. 1: Eidophor system comprises: (1) Projector; (2) Projection light beam hood; (3) Color wheel; (4) Auxiliary services, vacuum pump and cooling system; (5) Projection lamp; (6) TV receiver circuits

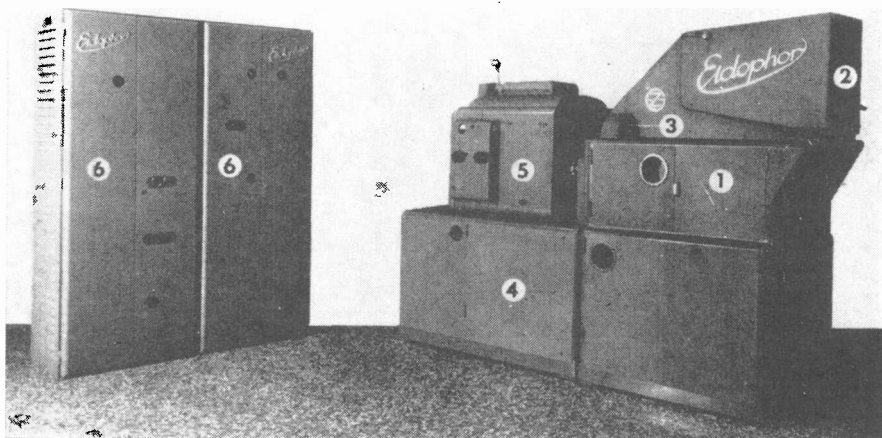
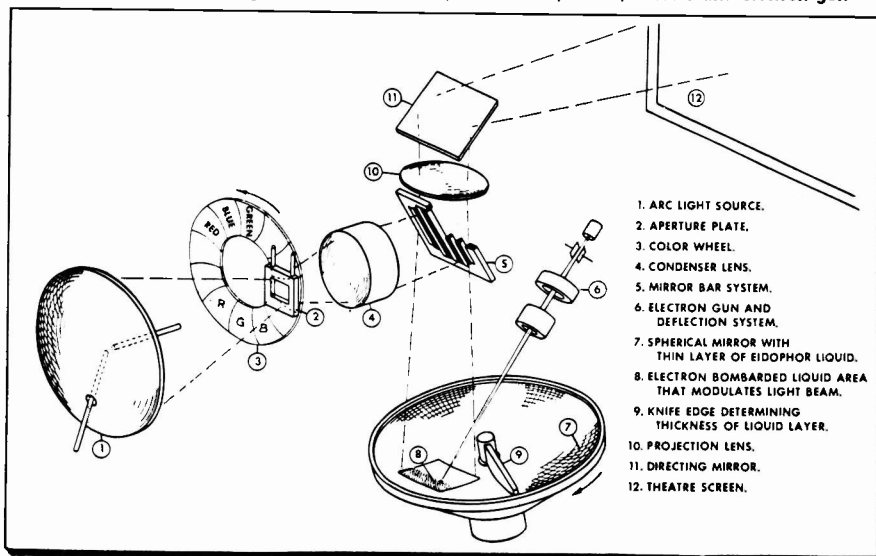

Fig. 2: Operational diagram shows arc source, color wheel, lenses, mirrors and electron gun



# Lightning Protection

Common grounds, parallel conducting paths, and damage from high current surges. Protection of

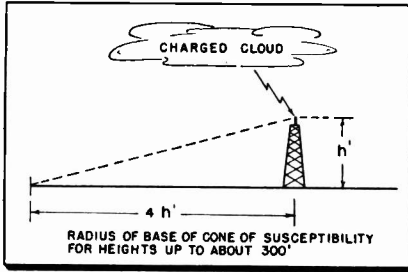

Fig. 1: Probable annual incidence of lightning strokes (I) to a radio tower. Computation:  $I = \text{Annual no. thunderstorm days (D)} \times \text{Stroke factor (S)} \times \text{Susceptible area (A)}$ . Example:  $D = 35$ ,  $S = 0.28$ ,  $h = 250$  ft.,  $A = 16\pi h^2 = 0.113$  sq. mi.  $I = 35 \times 0.28 \times 0.113 = 1.1$  strokes.

By **D. W. BODLE**,  
Bell Telephone Laboratories  
195 Broadway, New York 7, N. Y.

**E**QUIPMENT in fixed stations of a mobile radio system is susceptible to damage from lightning strokes to either the antennas or the connecting power and land communication facilities unless special protection is provided. The problem, however, is not alone one of protecting the station equipment but consideration must also be given to the protection of the connecting facilities to insure their continuity of service.

Fixed stations located in rural areas present a more difficult lightning protection problem than the urban installations, but the protection practices employed in each case are basically the same. Stations in sparsely settled areas are generally more exposed not only to strokes to the antennas but also to destructive surges that enter the station equipment and tower lighting circuits from the connecting power and communication facilities. These connecting facilities are usually of aerial construction and as a rule are not as well grounded as in more built-up sections. In urban areas several factors tend to reduce the incidence of lightning trouble such as other high structures that divert strokes from the antenna, and water mains, gas pipes and other underground metallic structures which provide good station grounding. The connecting

facilities in urban areas are frequently underground and have adequate conductivity to dissipate heavy stroke currents.

## Lightning Damage

Lightning strokes directly to antennas are not uncommon. The grounded structure type of antenna does not require protection, but with the coaxial type a discharge gap between the "whip" and the "skirt," or some form of  $\frac{1}{4}$  wave shorting stub connected to the coaxial lead-in close to the base of the antenna, should be provided to prevent arcing between the inner and outer conductors. Such a shorted stub, tuned to  $\frac{1}{4}$  of the wavelength of the station's operating frequency, will not attenuate normal transmission appreciably, but will introduce a considerable loss to spurious signals such as lightning surges. The coaxial lead-ins commonly used on poles and towers have relatively high dielectric strength. Therefore, arcing is more likely to occur at the equipment end of the lead-in in the patching line or in radio equipment.

For example,  $\frac{3}{8}$  in. diameter air dielectric line has the lowest breakdown strength of the lines customarily used and will withstand a surge potential of about 7000 peak. The  $\frac{1}{8}$  in. diameter line and the solid dielectric lines will withstand materially higher voltages. A discharge gap in the antenna will divert a large portion of the stroke current to the coaxial "outer" and the voltage between the inner and outer conductors at the antenna will be that of the arc drop in the gap. However, as the current flows down the outer conductor to ground, the gap drop is supplemented by another potential that builds up between the inner and outer conductors. This voltage is approximately equal to the product of the resistance of the coaxial outer and the surge current flowing in it and is maximum at the terminal end of the line. When the coaxial outer is paralleled by other conducting paths such as a metallic tower structure or a wire when the line is supported on a wooden pole, the combined conductivity is usually enough to hold the voltage between the inner and outer conductors to

Fig. 2: Station grounding arrangement used by Bell System for one-story building with separate tower

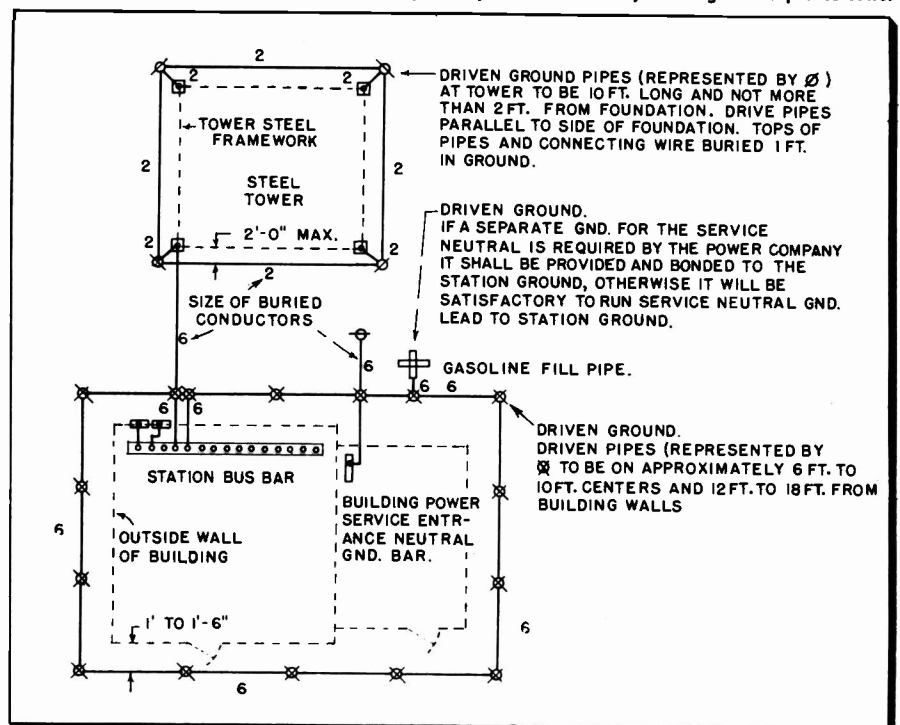



# for Fixed Radio Stations

**discharge gaps provide three important means for avoiding equipment connecting facilities must also be considered to preserve continuity of service**

below the breakdown strength of the line and the connected equipment.

In addition to the problem of dielectric failure, stroke currents subject coaxial lines to magnetic forces directed radially inward which tend to crush the line. The likelihood of crushing may be substantially reduced by providing parallel conducting paths as discussed later, thereby reducing the current in the coaxial "outer."

Surge voltages may also appear between the conductors and conduit of the tower lighting circuit by virtue of stroke current in the conduit. However, it is unlikely that insulation breakdown or lamp damage will occur except on very large stroke currents because of the conductivity of the metallic conduit and other conducting paths in parallel with it.

Sizeable surge currents in the antenna structure may result from a stroke to ground relatively close to the tower. However, the resultant voltage will, in general, be of lower magnitude than those caused by direct strokes to the antenna or tower and do not constitute a serious protection problem.

## Exposure to Direct Strokes

Strokes directly to the station grounding system are unlikely for the buried wire of the grounding system will usually be within the cone of protection of the tower.

The power and communication facilities serving stations in rural areas are usually exposed to direct lightning strokes and also to lightning surges from the rise-in-potential of grounds at other points on the systems such as in customers premises, flash over from guys, etc. Field investigations have established that surges of such origin may damage station equipment and tower lighting. Since rural power lines are generally not as well grounded as urban lines and also the communication circuits may be more exposed, these facilities in themselves present a considerable protection problem to insure continuity of service.

The results of recent field measurements indicate that the annual

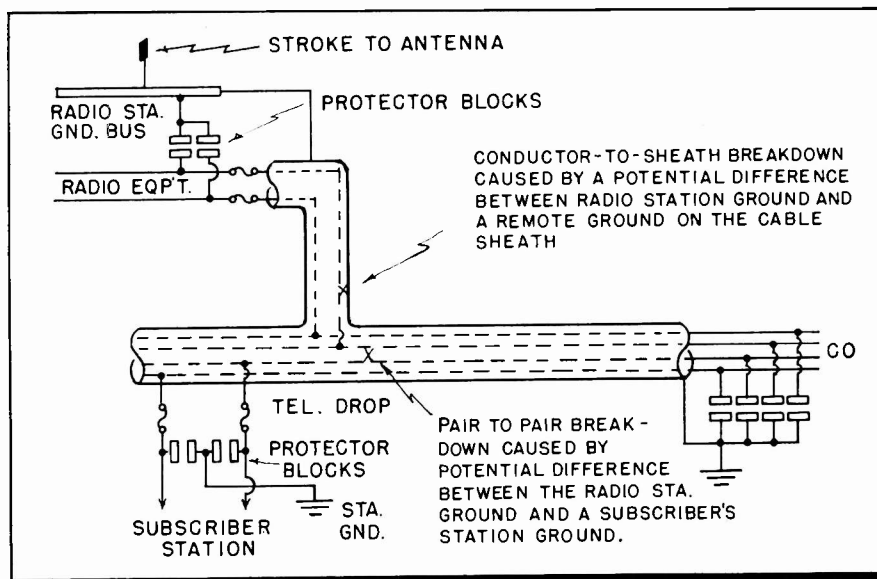

Fig. 3: Failure in telephone cables serving radio station with standard lightning protection only

incidence of strokes to ground is about 9/sq. mi. in areas having 30 to 35 thunderstorm days per year as shown on an Alexander isoceraunic map. In areas having 50 to 60 thunderstorm days annually the incidence of strokes to ground is in the order of 20/sq. mi. A radio antenna, however, is not just an exposed point, but is susceptible to strokes that would normally strike the earth within a considerable area around it. The probable annual rate of strokes to a radio antenna 250 ft. high in an area having 35 thunderstorm days annually is in the order of one stroke per year (Fig. 1). This approximation is based on the assumption that there are no objects such as tall buildings, trees or power lines projecting through the cone of protection of the tower. The presence of such projecting objects will divert strokes from the tower and lower its stroke incidence. Because a tower is located on a hill it may not necessarily have a higher stroke incidence, especially if there are other hills in the vicinity; however, the stroke incidence may be somewhat higher if it is on an isolated hill or the approach of the storms is over lower altitude terrain.

Magnetic link measurements secured during a period of approximately two years on a 250 ft. metal

antenna tower located in an area having 40 thunderstorm days per year indicate that the tower sustained four direct strokes. The following table gives the magnitude of stroke currents recorded:

Measuring Period	Peak Amp. to Gnd. Tower	Coax. Line
July-Dec. '49	9100	200
Jan.-Dec. '50	7700	1900
Jan.-Dec. '50	38000	6000
Jan.-Aug. '51	19000	200

During the period of these measurements it appears that the incidence of strokes to the tower was between one and two per year, which is in good agreement with the theoretical case previously discussed. In a period of one year the station was off the air several times during lightning storms because of tube filament damage and operation of fuses in the radio power supply circuits. Coincident with failure of radio equipment, lamps in the tower lighting burned out and the commercial power line serving the station was disabled on several occasions for periods ranging from 20 min. to 12 hours. Since the instances of station trouble exceeded the number of direct strokes to the tower, it appears that some lightning surges entered the station over the connecting facilities. After some modi-

# LIGHTNING PROTECTION (Continued)

fication of the existing protection and the addition of arresters on the branch circuits, lightning troubles at this station are no longer a problem.

## Protection Methods

The following protection methods have been successfully employed in the protection of land based stations:

1. Apply common grounding to all equipment, metallic structural members and facilities entering a station.
2. Provide a discharge gap in the antenna or a  $\frac{1}{4}$  wave shorting stub in the coaxial lead-in cable close to the antenna.
3. Provide a conducting path in parallel with the coaxial line to reduce voltage between inner and outer conductors.
4. Install lightning arresters on the secondary service leads and lower voltage protectors on branch circuits feeding electronic equipment.
5. Provide discharge gaps on the communication circuits to equalize potentials and conduct surge currents to ground. In cable areas when conditions are severe, additional protection may be secured through the use of higher dielectric cable or conductors in parallel with the cable sheath.
6. For stations without standby facilities install adequate power line protection to help insure continuity of service.

Public metallic water pipes provide adequate grounding from a protection standpoint, but in locations where this means of grounding is not available it is necessary to construct a station ground system. Experience indicates that when setting up the requirements for a "made" ground it is preferable to

specify only the dimensions of the buried network and its general configuration rather than its resistance value. Because of the wide variations in soil conditions, the cost of securing a ground of specified resistance may be unduly high and the money can be more profitably spent on supplementary protection on the connecting power and telephone lines.

Common grounding will reduce potential differences between the various metal components of the station. It is well therefore to provide a station ground bus to facilitate the common grounding of such things as the arresters on the power and communication circuits, the outer conductors of coaxial lines, conduit, equipment cases, gas and oil pipes, plumbing and metallic members of the building structure. The antenna tower, if metal, should be connected to the station ground. The tower conduit and coaxial cable outer conductor should be securely bonded to the tower at the top and bottom and also at frequent intervals in a manner to provide good electrical connection. Fig. 2 shows a characteristic station grounding arrangement employed by the Bell System.

Some antennas have incorporated in their design a star shaped discharge gap having an operating value of about 4000 peak v. to prevent flash-over in the coaxial line and connected circuits. A star gap has proven to be an effective protection device. However, it appears that in some recent antenna designs employing multiple arrays, the star gaps are being omitted because of mechanical complications. This makes it necessary to substitute other methods of protection such as the  $\frac{1}{4}$  wavelength shorting stub installed at the base of the antenna. Surge

measurements using a 52 ohm solid dielectric line and a current wave of  $6 \times 15 \mu\text{sec}$  (peak current attained in  $6 \mu\text{sec}$ , decaying to  $\frac{1}{2}$  peak value in  $15 \mu\text{sec}$ ) indicate that a  $\frac{1}{4}$  wavelength shorting stub is a satisfactory alternative. The following table gives a comparison of the residual voltage across the load termination for various surge currents applied to the antenna whip.

Surge Current Pk Amp.	Without Gap or Stub	With Gap	With 11 in. Stub	With 55 in. Stub
1000	9000	190	240	310
5000	*	800	1200	1550
10000	*	1600	2400	3100

\* Above breakdown of coaxial connectors.

The desirability of some form of antenna protection is quite apparent, for without it the voltage across the load would be in the order of 9000 v./1000 amp. surge current. The star gap gave a reduction in voltage across the load termination in the order of 50 to 1 compared with about 35 to 1 with the stub. The gap is therefore preferable to the stub when it is practical to incorporate such a gap in the antenna design.

## Susceptibility to Crushing

Small diameter air dielectric line is particularly susceptible to crushing, so it is desirable to provide a parallel conducting path to divert an appreciable amount of surge current from the outer conductor. When the line is supported on a metal tower, frequent bonding to the structure will provide sufficient parallel conductivity to prevent crushing of the coaxial outer. With lines supported on wooden poles, a conductor should be fastened to the side of the pole opposite the line and bonded to the coaxial outer at both the top and bottom of the pole. Since the division of the current is determined chiefly by the self impedances of the conductor and the coaxial line, copper

Fig. 4: (L) Impedance of power conduit helps protect equipment

Fig. 5: (R) Power circuit without interconnected neutrals or bridging gap

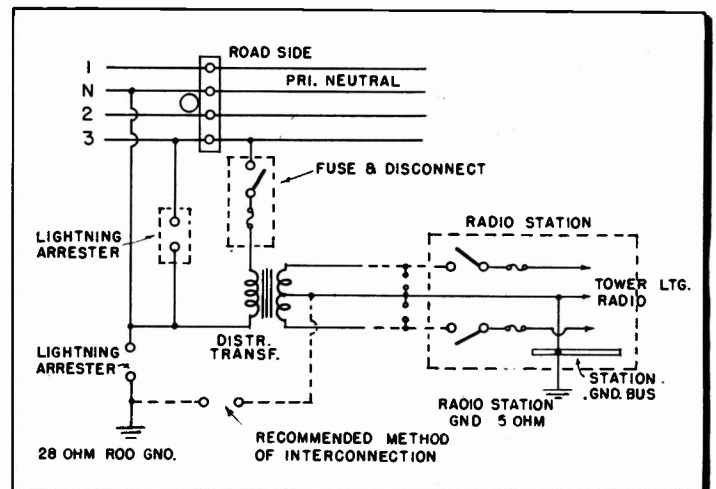
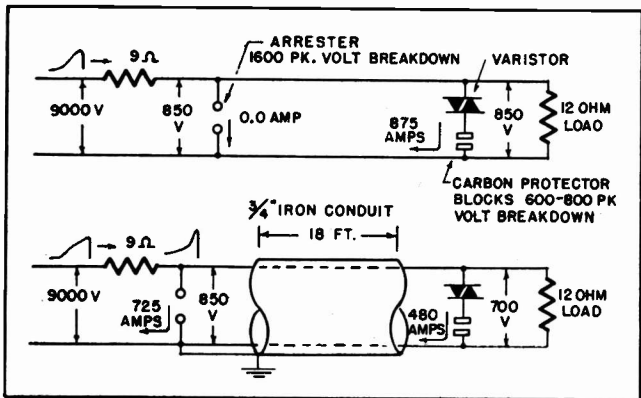

## Lightning Protection

wire as small as No. 10 gauge has been used successfully for paralleling purposes. In general, the surge current divides about equally between the line and the parallel conductor and crushing is unlikely to occur except with unusually heavy surge currents.

With the smaller size lines or when the distance between the tower and the station is relatively long, it may be desirable to run the line in metallic conduit. At the tower end, the conduit and the coaxial outer conductor should be commonly bonded to the tower structure and in the building the conduit and coaxial outer should be connected to the station ground bus. The conduit, in addition to giving mechanical support, provides additional conductivity in parallel with the coaxial line, materially reducing the possibility of crushing. However, there have been field reports of lines being crushed by water freezing in such conduit runs so precautions should be taken to prevent the accumulation of water in them.

### Land Communication Facilities

Remotely controlled fixed stations are common in a mobile system and consequently the land communication facilities are a vital link in the service. These stations are frequently in isolated locations where the antenna and connecting facilities are highly exposed to lightning. When the communication circuits are brought in by open wire, the protection problem is somewhat less than when small size cable is used. Although open wire will withstand relatively high lightning potentials, protection must be provided to equalize potentials where such circuits enter the station or connect with cable. At the station, all conductors should be connected to the station ground through discharge gaps. When open wire connects with cable, it is well at that point to provide a discharge gap between the sheath and each conductor in the cable. In addition to the gaps, grounding of the sheath at the junction will increase the protection and is particularly desirable in the case of small diameter cables having high sheath resistance.

An open wire line on jointly-used poles with a multi-grounded neutral power line having an operating voltage above 2900 v. rms to ground should be provided with gaps having a breakdown of about 3000 v. rms (.030 in. gap) connected between each open wire conductor and the multi-grounded neutral at intervals

of about  $\frac{1}{2}$  mi. In the case of ungrounded and delta systems, since a low resistance neutral is not available for grounding purposes, it becomes necessary to construct protector grounds of sufficiently low resistance so that the voltage drops across these grounds during a power contact will not exceed about 3000 v. rms. However, the cost of constructing these grounds, which may be

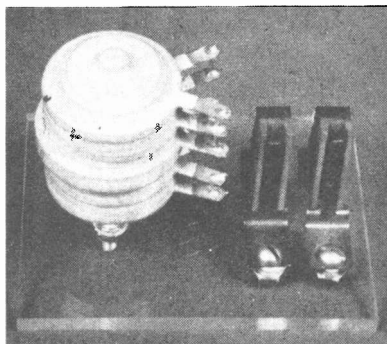

Fig. 6: Two-section varistor assembly and two carbon block discharge gaps provide for low voltage circuits

quite high, is a factor in considering the use of this type of protection. These gaps serve two purposes: first, they limit the voltage across telephone protectors located at other points; and second, they assist in the rapid de-energization of the power line by providing a low resistance path to ground for faulty current.

The protection of small size cable presents a greater problem as it is vulnerable to lightning damage from a rise-in-potential of the radio station ground and also from strokes directly to the cable and associated plant. Current from direct strokes to the antenna will divide between the station ground, the power line and the telephone line in inverse proportion to their surge impedances. As shown in Fig. 3, current entering the station ground will produce a potential with respect to a remote ground such as the protector ground at a subscriber station, and this difference in potential may cause pair to pair trouble. Furthermore, current in the sheath resulting from a heavy stroke to the antenna may cause dielectric failure between the core conductors and the sheath.

It is necessary, therefore, to limit these potentials with discharge gaps connected between the sheath and all cable conductors entering the station. The sheath should be connected to the station ground as discussed previously in the section on common grounding. This will equalize potentials at the station, but with long runs of small diameter cable, it is often necessary to provide equalization at intermediate points. It has been found in practice that adequate protection will generally be provided

by applying discharge gaps to all cable conductors at intervals of about  $\frac{1}{4}$  mi. between the station and a point where the surge current in the sheath has been substantially reduced by shunt paths to ground. Some latitude is permissible in the selection of these equalization points and preference should be given to locations where favorable grounding conditions exist. When a cable is supported on poles with a multi-grounded neutral power system, bonding of the sheath to the common neutral is in most cases more desirable than a made ground. Such interconnection provides additional grounding paths for lightning currents in either system. In situations where the exposure is particularly great and the earth resistivity is high, it may be necessary to use higher dielectric cable or parallel the sheath with wires installed aerially or buried under the cable to reduce the sheath current and thereby the resultant core-sheath voltage.

### Power Line Surges

The equipment and tower lighting in stations served by overhead power lines are vulnerable to damage from lightning surges originating on the power system. Experience indicates that in suburban and rural areas, the probability of trouble from this source is sufficient to justify the application of special protection on the service conductors and the branch circuits. The installation of secondary circuit power arresters (1.6-1.8 kv. operating potential) installed on the service conductors either at the weather head or service cabinet have provided satisfactory protection for the miscellaneous power and lighting equipment customarily operated on branch circuits.

With an underground power service in either iron conduit or employing steel clad cable, it is often desirable to install a distribution type arrester (about 3.0 kv. breakdown) on the secondary conductors at the power pole. The ground lead of the arrester should be connected to the conduit or cable sheath and at the station the conduit or sheath should be bonded to the common building ground. This arrangement utilizes the impedance introduced by the metallic covering over the service conductors to reduce the duty on the station arresters and materially raise the level of protection.

Secondary circuit arresters operating at 1800 peak v. will not adequately protect radio equipment. Therefore, a low voltage protector operating at 600-800 peak v. has been used extensively in the Bell System

(Continued on page 48)

# Servicing Vibrators

## Maintenance of Synchronous and Non-Synchronous Types Through

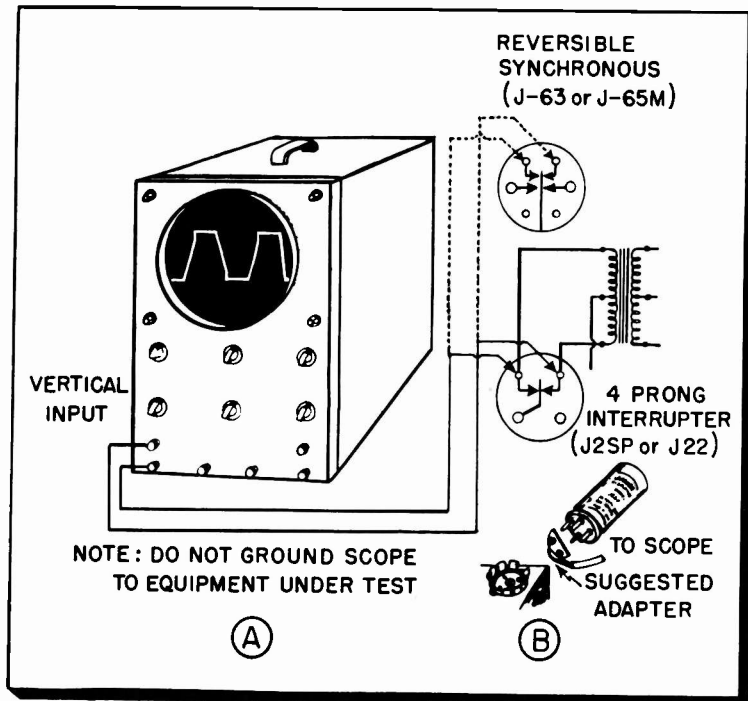

Fig. 1—A) Vibrator connections to oscilloscope. B) Adapter set-up.

• The oscilloscope is a valuable tool in the proper maintenance of vibrators and vibrator power supplies. The understanding and interpretation of the operating waveform of a vibrator will give the servicer important information on the vibrator and its associated components. "The picture tells the story."

The oscilloscope employed may be any standard type having an internal sweep circuit. The vibrator waveform is best observed across the primary contacts of the vibrator. These primary contacts are connected to the vertical input of the scope. This connection applies to both general types of vibrators, the interrupter (non-synchronous) and the synchronous. Fig. 1A is a pictorial diagram that shows the circuit hook-up to be made in each case; two common types of auto-radio vibrators are assumed. The proper primary contact connection to other types of vibrators can be ascertained by referring to a suitable vibrator replacement guide.

To simplify the testing of units during operation, a thin adaptor can be readily constructed, as shown in Fig. 1B, with correctly attached leads inserted between the vibrator and socket.

The following oscilloscope adjust-

ments are made, previous to an inspection of the waveforms:

1—The vibrator contact connections are applied to the vertical input of the oscilloscope, and the vibrator power supply turned on.

2—The "synchronization selector" knob on the scope is set to "internal."

3—The sweep frequency range control is set to approximately 30-100 CPS.

4—Initially, the "sync" control should be at zero setting.

5—The "fine frequency" sweep control should be adjusted until two full square waveforms are stopped on the screen.

6—The "sync" control should be advanced until the waveform is stationary on the screen. The final setting is normally at a low level—15% or lower.

### Advantages of Waveform Tests

Variation of all other controls to center and focus the waveforms can be made to suit the operator.

A few general comments re waveform analysis may be in order, before we make the analysis proper. Through waveform analysis, it is possible to ascertain the general condition of vibrator-powered equipment. More specifically, we can:

1—Anticipate the remaining life of a vibrator in service.

2—Ascertain the cause of excessive "hash" noise in the receiver, and determine whether it is due to the vibrator, or some other component.

3—Check new vibrators for proper operation.

4—Detect bad buffers or shorted transformers.

5—Observe excessive secondary or load currents.

6—Determine the cause of poor output voltage, localizing it to the vibrator, or its associated power supply, or the rest of the receiver.

### Variations in Waveforms

The service engineer must remember that the vibrator is an electro-mechanical device of considerable complexity. Each individual unit in proper operation will show some variation in waveform from the ideals illustrated in fig. 2 and 3. This individuality must be kept in mind when interpreting waveforms. Experience will permit the proper interpretation of vibrator waveforms.

Fig. 2, sketches A-E, illustrate the waveforms obtained in an interrupter or non-synchronous type vibrator. This type of vibrator has contacts operating at the primary low voltage only. Rectification is achieved by other means (than vibrator action). Steady load conditions were maintained during the tests, as indicated by the waveforms.

### Normal Waveform

Waveform 2A shows no bounce during contact closures. The broken lines on the diagonal are indicative of good buffer action. A new vibrator with proper buffer will show these breaks under test. As contacts wear, the contact closure is reduced, and the buffer closure will increase, tending to produce a solid line (instead of a broken one).

2B is an illustration of a condition called *single-stepping*. Single-stepping indicates a poor starting action. A vibrator that shows single-stepping on starting voltages of 5.5 V or more is either defective or worn. In service it will fail in a short period through fuse-blowing or poor output. Proper vibrator operation requires full reed-contact operation.

2C shows *contact bounce*. The waveform indicates a worn vibrator, in the case of a used unit. The service result will be lower output voltage and a very high "hash" level.

An extreme bounce like the one

# With the Oscilloscope

## 'Scope Waveform Checks. Normal and Abnormal Wave Shapes.

shown in 2C should not be thought of as the result only of dirty contacts—such a condition is occasionally found in a new component, and is due to poor vibrator adjustment. Dirty contacts generally show up as very small-amplitude bounces in the contact waveform. A short period of operation will normally correct this condition when it occurs in a new vibrator.

### Unbalanced Closure; Arcing

The *unbalanced closure* indicated in 2D is the result of poor adjustment or, in some instances, a bad buffer. Try another vibrator in the circuit, to find out whether or not the original one is defective. If the trouble lies in the vibrator, the unit may give partial service, but is a poor risk. This is the typical vibrator that "sticks" after short service.

2E indicates arcing at contacts. The trouble can lie either in the vibrator or its associated circuit. Try another vibrator to pin down the source of the fault. If the waveform becomes normal, the original vibrator is defective; if it

served across the primary contacts show this secondary contact operation in the form of a small voltage drop when the contacts connect the load. (See fig. 3A).

3A is the ideal wave, and shows no bounce during contact closure. The peaks or horns at the beginning and end of each closure are the secondary rectifier contacts closing later and opening sooner than the associated primary contacts. Note the same broken buffer closure line characteristic of interrupter vibrators. As the vibrator wears, the line becomes longer, and manifests decreasing break. This ideal waveform shows perfect timing of contacts, which results in high output and low "hash" level.

### Secondary Spacing

3B shows a condition known as *wide secondary spacing*. The secondary contacts close later, and open sooner, than they normally do. The condition results in lowered voltage output, and a higher level of "hash." Service failure of the unit will not ordinarily occur as a result of this defect. The lower output voltage and "hash" level should be judged for acceptability.

3C represents a condition known as *close secondary spacing*. This condition will result in contact arcing and fuse-blowing in vibrator operation. A synchronous vibrator that produces waveforms lacking horns or tips should be removed from service.

### Care in Interpretation

Care should be taken in interpreting the condition present when this waveform appears for a synchronous vibrator. If the secondary load is off (i.e., the set is not warmed up) or circuit trouble is present, the waveform obtained may resemble the one characteristic of a normally-functioning interrupter vibrator. The trouble in such a case can be localized by substituting a vibrator in known good condition for the one present, and noting results.

3D—*secondary contact bounce*—illustrates a fault that will result in lower voltage output and high "hash" level. In a vibrator with service, the waveform is an indication of imminent failure due to too low voltage output. The condition is normally caused by reduced secondary contact pressure due to wear. Care should be exercised that small-amplitude ripple, produced by dirty contacts in some new units, is not interpreted as true contact bounce.

3E—*primary contact bounce*—indicates a condition that will result in the

same operating problems as secondary contact bounce.

The following general maintenance notes may prove helpful. A good vibrator for six-volt equipment is designed and tested for the following standards of performance:

1—Low voltage starting—i.e., 5 V or lower.

2—Good waveform at nominal six

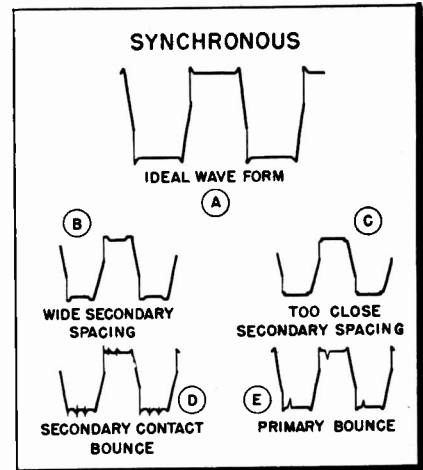

Fig. 3—Normal and abnormal waveforms for synchronous vibrator.

volts, indicating high voltage output and low generated "hash" level.

3—Operation at over-voltage for normal mechanical performance, and, in synchronous units, absence of arcing.

The technician can use these measures of performance as a guide to vibrator condition. New units can be tested for good performance before insertion. Contact dirt, from shelf life and oxidation, can be observed and run off before placing the component in service.

### Dating Vibrators

Vibrators should be marked with "date in service" for correct measure of performance. With this data on the unit, hours of service can be readily calculated. Good maintenance for vibrators involves observation of the waveform of the unit in service, when the associated equipment is undergoing bench tests. It is possible to anticipate vibrator failure from normal wearing out through service life data and waveform analysis.

Removal of a vibrator in the last twenty-five per cent of its normal life is far less expensive than its replacement when it fails completely, since a separate maintenance job will be necessary at such a time. (From a booklet published by the James Vibrapower Company.)

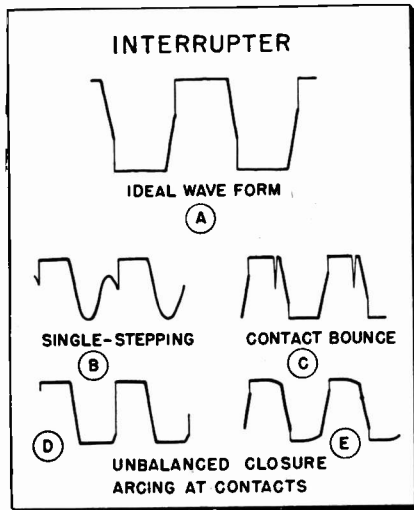

Fig. 2—Normal and abnormal vibrator waveforms for non-synchronous vibrator.

remains abnormal, a component in the associated circuit is to blame.

If circuit trouble is indicated, check the buffer first, then the rectifier, filter and external circuit. If the fault has been traced to the vibrator, the unit should be discarded.

The synchronous-type vibrator has both primary contacts at low voltage and secondary contacts at high voltage. The second set of contacts close slightly after the primary ones, and provide output rectification. The waveform ob-

# Servicing Phono Equipment

**Fine Grooves Plus Light Weight Pickups Make These Critters Very**

• No one will question the fact that many substantial benefits have accrued to the phonograph record user since the introduction of microgroove records—both 45's and 33's. Not only has the consumer been provided with more compact and more durable records, and with more playing time for less money, but also a general upgrading in the quality of recordings is making available greater tonal range, greater dynamic range and less distortion.

The assimilation of the new types has not been without its discomfites, however, both to the user and to the dealer who sells him instruments, records and service.

This is partly due to the fact that we are, in general, dealing with much more delicate equipment, as well as a delicate medium.

A great deal of the trouble can be overcome by educating the user on the little tricks and techniques necessary for living in harmony with his record player. There are also some maintenance demands on the user, which we shall come to.

## Gram-Ounce Equivalents

1 gram	—	.035 oz.
(metric)		(av.)
6 grams	—	.21 oz.
		(about 1/5 oz.)
7 grams	—	.245 oz.
		(about 1/4 oz.)
15 grams	—	.525 oz.
		(about 1/2 oz.)
22 grams	—	.77 oz.
		(about 3/4 oz.)
28.35 grams	—	one oz.

First, there are some facts about which the serviceman needs to be reminded. Some of these things seem small and obvious. But we have discovered from talks in the field and from letters from our readers that many of these small and obvious things are being overlooked.

It seems that in all too many cases the technician working on a complaint plunges immediately into the service notes and starts losing his mind over pawls and pinions and cams, change cycles, set down points, etc., when all along the trouble might be something as simple as a worn needle. It's something akin to tearing a circuit apart

without first checking the tube (which happens to the best of us every now and then).

To get down to cases, one of the most common complaints with microgroove players is groove-skipping and "skating" of the tone arm across the record. When the pickup or needle pressure is properly adjusted to the 6 or 7 grams recommended by the manufacturer, it is truly "as light as a feather." If you doubt this try holding your finger down on a needle pressure gauge so that it stays at seven grams (without resting your hand on anything). Incidentally, if you don't have a needle pressure gauge, you can't do a thorough job on microgroove players and changers . . . but we'll go into this more in a minute.

It might be pertinent at this point to mention why the needle pressure is so light on LP's. In reducing the needle tip radius to 1/3 of the size of 78's (namely from .003 in. to .001 in.), we have reduced the area of the tip to 1/9 (because the area varies as the square of the radius). The pressure per square inch is therefore increased to 9 times what it was on 78's. In other words, in order to obtain a pressure per square inch *no greater* than it was on 78's, we must reduce the needle pressure to 1/9 of what it was on 78's.

Referring back to a pre-LP parts catalog, we find needle pressures of one ounce to 3 ounces, with the average about 2 ounces (56.7 grams). One-ninth of this would be 6.3 grams. Actually, the pressure per square inch on a 6 gram needle is in the neighborhood of 440,000 pounds!

At any rate, even though the pressure per square inch is very high, the 6 gram pressure on the almost infinitesimal .001 tip is very light. As a result, it is relatively easy to cause groove-skipping.

### Groove Skipping and Skating

For instance, shutting a slide drawer, or putting a new record on the changer while one is playing are sufficient to cause the needle to jump. If the turntable is not full-floating on springs, and if it is not level, groove-jumping can result if the pitch is toward the center. This is one of the first things you would want to check, as a matter of fact.

Accumulation of dirt on the needle as a result of tracking can permit the needle to skate. Like drawer-slamming and record changing, this is one of the things you must educate the customer about, since this "fuzz" can collect during the playing of one record. This seems to be especially true if (1) no static eliminator has been used on the

record, or (2) if static eliminator has just been applied and this is the first run, or (3) if the static eliminator has been on a long time and has lost its usefulness.

Static eliminator, incidentally, is something the writer recommends highly to keep records clean, and consequently quiet.

### Trouble From Worn Needle

As for the "fuzz," the customer should get in the habit of attending to it regularly. The writer keeps a small piece of rubber sponge (used to apply static eliminator) handy to the changer, and uses it effectively to brush off the fuzz without danger to the needle. On magnetic cartridges with closely spaced pole pieces, it is a good idea to clean out the pole pieces once in a while, too. One of these days, no doubt, some changer manufacturer will incorporate a little brush on the side of the changer so that the needle rubs past it during the change cycle. Such a "gimmick" can already be observed on the Seaburg "45" juke boxes, which have two such brushes (since the tone arm plays on both top and bottom of the turntable) which are contacted every time a change cycle occurs.

Worn needles will often skip and skate easily. Up until recently, it was difficult to determine if a 1 mil needle was worn except by replacing it. But now, with the flurry of microscopes, a scientific inspection of the point is simple. We believe that every dealer who handles needles (and this should mean every dealer who handles phonographs and/or records) should try to obtain a microscope. In most cases, you can arrange this with your needle supplier, but failing this, you'll find you can obtain one quite reasonably from an optical supply house, some camera stores, and of course, the ubiquitous pawnshop. Bring a needle with you to assure yourself that the power is sufficient for the purpose.

The microscope test is probably one of the most potent merchandising tools yet developed to sell the consumer on the need for a new needle, since it is evident from the appearance of the point under magnification that deterioration of the record grooves can be occurring long before distortion is audible. It is also a powerful selling point for diamond points, since careful watching for needle wear on the less expensive tips will show how often they need replacement.

Not only can a worn needle cause groove skipping, but as mentioned above, it can cause excessive record

# for Microgroove Discs

**Sensitive; Checking Obvious Points First Often Reveals Trouble**

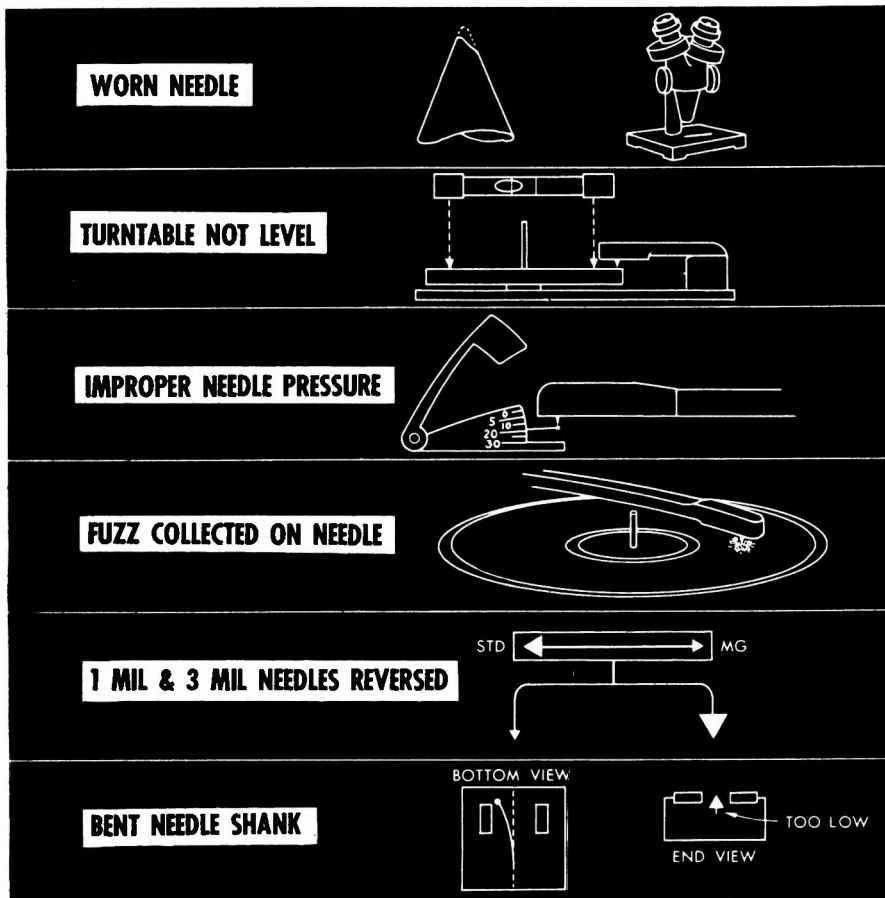

wear and deterioration, and it can cause the needle to get "hung up" in a groove. Both groove-skipping and "stuck" needles can cause irreparable damage to a record, so that the same thing happens every time the needle gets to that point in playing.

In addition to these things, a bad needle can cause distorted sound. Just as we suggested record changer repairs be stalled off until all the small, obvious details are checked, we would also suggest that any examination of the audio circuits in back of the pickup be stalled off until the needle is examined.

Other needle troubles that can give rise to customer complaints are (1): the wrong needle tip may be in use. This could be caused on initial installation of the equipment, or by a subsequent needle change (especially if done by the customer). Not all microgroove needles are marked with a red dot, and it is impossible to tell the size by eye. Consequently, installation instructions of the needle manufacturer (and his color coding, if any) must be closely observed. In this same connection, the

needle may have been improperly or incompletely seated, especially if installed by the customer.

(2) On GE type cartridges, the shank of the stylus may be bent over toward one of the pole pieces, or (3) the needle tip may have become pushed down too far between the pole pieces. These troubles can be corrected by a hand with a light touch. The writer has used a straight pin as a prying tool to effect these corrections (which have sometimes been necessary on new needles).

On conventional type needles with relatively long, delicate shanks, the shank can become bent so that the tip does not ride squarely on the record. It is relatively difficult to correct this unless you have a new needle as a model to work from.

Needle pressure can be too light, which would aggravate skipping, or it can be too heavy, which will accelerate both needle and record wear. Three changers which the writer checked recently *all* ran over 10 grams, with a maximum of 15 grams. Reducing the pressure to a figure somewhat closer

to the design center necessitated an orientation program with the users (who were not hitherto accustomed to the necessity of treating their changer so gingerly) but improved results, and will no doubt increase the life of the needles considerably. In this connection, it probably doesn't pay to be too precise, or that is what many servicemen feel with whom we have discussed the subject. In other words, 6 grams may be OK for the hi-fi fan who wants to have the ultimate in his equipment and is prepared to take a little trouble with it. But for the non-technical customer who would prefer to have his equipment "fool proof," 8-10 grams is probably a better compromise.

Troubles due to variations in the records can be even more troublesome on light weight pickups than with the old type. Slipping is not uncommon with the smaller records, causing an objectionable wow. Non-standard thicknesses and run-out grooves (to cycle the changer) can also cause trouble. Records which are particularly thin and light can fail to fall down properly from the record shelf. As for slipping, the writer has one clear Vinylite 10" long-playing record which will not play without slipping whether it is the only record on the turntable, or whether it is on top of some others. To correct slipping, the author has found it helpful to put a paper jacket from a 7-inch record underneath the trouble-making record.

This, again, comes under the heading of customer education. And while you're about it, anything you can say to exhort the customer to take good care of his microgroove records will be greatly appreciated in the long run. We have already mentioned the use of a static eliminator. In addition, records should be immediately returned to their jackets after use, to prevent picking up dust, dirt and small particles. Also, it's a good idea to flex the jacket a little, so that the record isn't scraped on the way in. Customers should be warned to try to keep their fingers off the playing surface. Another good idea, we believe, is to discourage them from amusing themselves by playing long-play records at higher speed, or 78's at a slower speed. The latter, with a 3 mil point, will have greatly increased weight on it, since the pickup spends a much longer time riding around the grooves and "rests" longer in one spot.

Attention to the small details of levelling; the right needle, proper needle installation, etc. will pay off in better consumer "public relations" and reorders as a result of word of mouth advertising.

# Recording Binaural

**Use of LP discs having two recorded bands offers a very compatible and practical binaural record system. Great new market potential indicated for record player manufacturers.**



Author viewing binaural cut in process on special recording lathe

**By EMORY COOK**  
*Cook Laboratories*  
*Stamford, Conn.*

**I**F the advantages and potential wide sales appeal of binaural sound are to be exercised, the realm of disc-recording, where cost and compatibility factors with existing standards are favorable, offers great possibilities. Let us then review the several ways in which a synchronized double track in disc can be produced:

1. A binaural recording can be made on opposite sides of a disc, playing back both sides simultaneously. This method is not very practical however, because stampers cannot possibly be centered and aligned in the press in the necessary rotational accuracy, and a wholesale redesign of playback turntables would be necessary.

2. Interleaved grooves are another theoretically possible means of binaural disc recording. This method however is costly to record and to playback and further, a great deal of special equipment would be necessitated.

3. A single sideband carrier system has been proposed, but the limi-

tations of this method are such that the frequency range of each "ear" is restricted to a low value that could not be considered acceptable from a fidelity standpoint.

4. To date then, it appears that by far the most compatible and practical system is that of placing two recorded bands on the same side of an LP disc as diagrammed in Fig. 5

As with ordinary recording equipment, the cutting styli move on a radius,—from outside in. Therefore existing recording equipment is easily modified to perform the mastering function. The playback arms may be integrated into a single arm containing two cartridges side by side as shown in Fig. 1.

## **Compatibility**

The confusion of multiple standards has already shaken up the record industry once or twice and another upheaval would probably be impossible. Therefore, both the binaural record and its playback means must be interchangeable with exist-

ing standards. Due to the halving of available elapsed time with two channels, the 12-in LP is a natural starting point. With a normal 12 minutes of binaural playing time and a possible maximum of 14-15 minutes, most musical requirements can be met. The method described here produces a record which can be played (one "ear" at a time) on existing equipment, and the binaural reproducing system will likewise play regular records by simply blocking one of the cartridges up off the record.

## **Accurate Radial Relation**

In Fig. 5 is shown the schematic arrangement for playing back the record of Fig. 4. Within the limits of travel in arc of the arm across the narrow band of grooves a high degree of accuracy of radial relation of playback points is obtained. In the practical case the positive error is made to equal to the negative error in terms of wavelengths,—at 1000 cps for instance. The maximum error then measures to be of the order of magnitude of 0.01-in. along the groove longitudinally at the middle of the record corresponding to less than a wavelength at 1000 cps along the groove. The purist might say here that we cannot tolerate a phase error of 180° in the range of maximum directional sensitivity of the human ear, but this is not true, and it is not a matter of "toleration" anyway unless we confine our remarks to the use of earphones as a listening medium. As a matter of fact, earphones can be given no consideration at all commercially. If we think in terms of spaced loudspeakers in a room then a full wavelength error at 1000 cycles can be thought of as corresponding to a motion forward or backward of one of the loudspeakers of about one foot, or a corresponding random motion of the listener in the room (such as turning the head) while the music is playing which is easily possible, in fact probable, without getting up from the chair.



# Sound on Discs

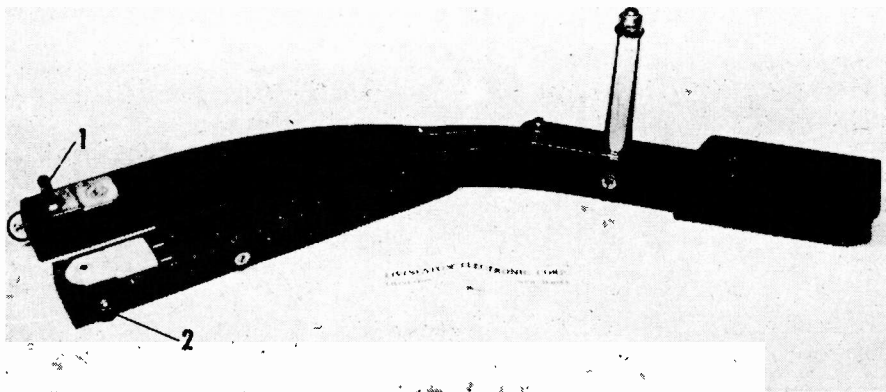

Fig. 1: Close-up of dual cartridge playback arm as manufactured by Livingston Electronic Corp., Livingston, N. Y. (1) and (2) are adjustment screws

A typical modified arm would display a dimension of  $10\frac{1}{2}$ -in. from pivot to farthest stylus, an offset angle of  $27.5^\circ$  and the standard spacing of  $1\frac{1}{8}$ -in. The fractional spacing is chosen rather than decimals to facilitate the rough adjustment by using a standard inch rule, where the points will fall into the indentations at the specified dimension.

The radial error is not much affected by the length of the arm, and short 12 in. turntable arms are candidates for conversion.

In order to permit equal tracking pressure of each point of contact, at least one and preferably both of the cartridges must be individually pivoted for the vertical plane, although of course, if one is tempted to put up with the inconvenience, two separate arms may be operated.

## Random Production Errors

No record is produced which is actually on center. The magnitude of the combined error in good commercial practice can hardly be reduced under .010-.015-in. The staggered method of interleaved grooves can not operate satisfactorily because of the centering problem alone, since there is a large angle subtended between the two points of pickup. However, the radial method is the least susceptible, in fact practically immune to centering errors such as normally encountered. But there is another and more insidious danger to watch against. In establishing a  $1\frac{1}{8}$ -in. dimension between points of pickup we must allow a tolerance.

Not only is it quite unthinkable to be able to align recording heads and styli on a lathe to .001-in. tolerance

for each and every master, but the metal parts, especially stampers used to mold pressings are basically 0.032-in. copper as regards mechanical strength. In the modern fast cycle press and in handling they become stretched, so that  $1\frac{1}{8}$ -in. may become distorted around the circle. Furthermore, non-uniform cooling of pressings just removed will produce a small eccentric shrinkage on one side of the record and not the other. All these errors are of course capable of being cumulative to the effect of at least 0.015-in., and therefore we must have a mutual "lost motion" in the  $1\frac{1}{8}$ -in. spacing figure of  $\pm .015$ -in. or thereabouts. However, since the record is started with pickups dropped in the spiralling lead-in groove, this does not mean that we shall have trouble

getting into the correct grooves; it merely means instead that there is to be a "free" lateral motion of one cartridge with respect to the other. However, the business of "loose pivots," i.e., rattles, in vertically pivoted arms is well known to produce non-linear effects at some mid-frequency. The answer to the problem is the packing of the pivot points with viscous damping, so that the compliance of the cartridge needle is two or three times higher than the viscous compliance for frequencies at and below the undamped lateral resonance.

In bringing binaural into focus as a practical medium, the cost factor is particularly important. A first reaction might be that the cost would be almost doubled but this is not the case. Binaurally, power output per channel can be *less than half* that of an equivalent monaural channel for the same apparent loudness.

## Using Twin Triodes

With the use of twin triodes the basic amplifier design may be doubled up (as in push-pull) without much additional cost. Since we certainly need no more than half the output power "per ear" the power supply is the same. The twin cathode, screens and plate supplies may be by-passed through common capacitors, since a moderate amount of crosstalk between channels is permissible. The only serious added cost will be that of the second output transformer, and means for reducing even that appear to be forthcoming.

In the "minimum" design of Fig. 2, there are only 16 one- or half-watt resistors, 4 audio capacitors and 4 tubes not including power supply

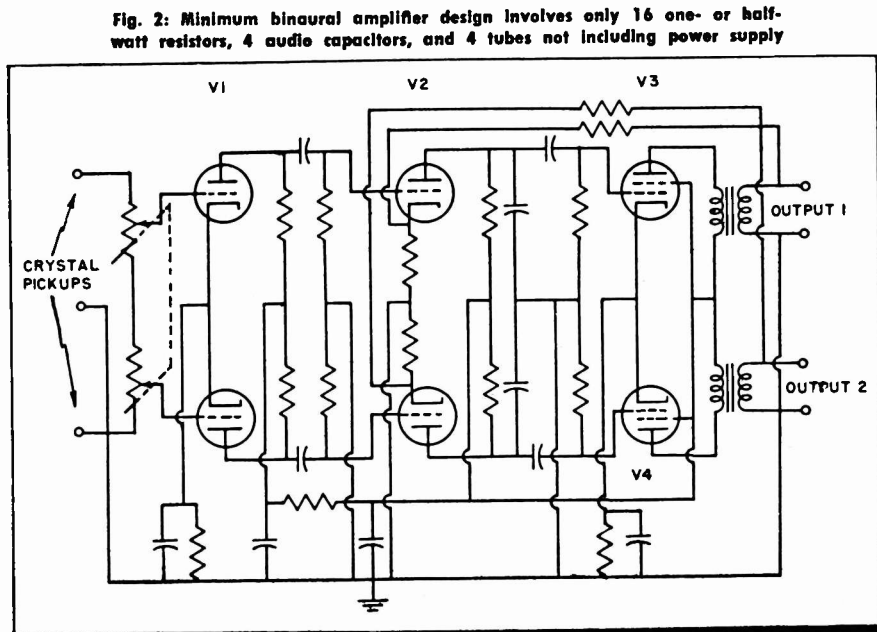

Fig. 2: Minimum binaural amplifier design involves only 16 one- or half-watt resistors, 4 audio capacitors, and 4 tubes not including power supply

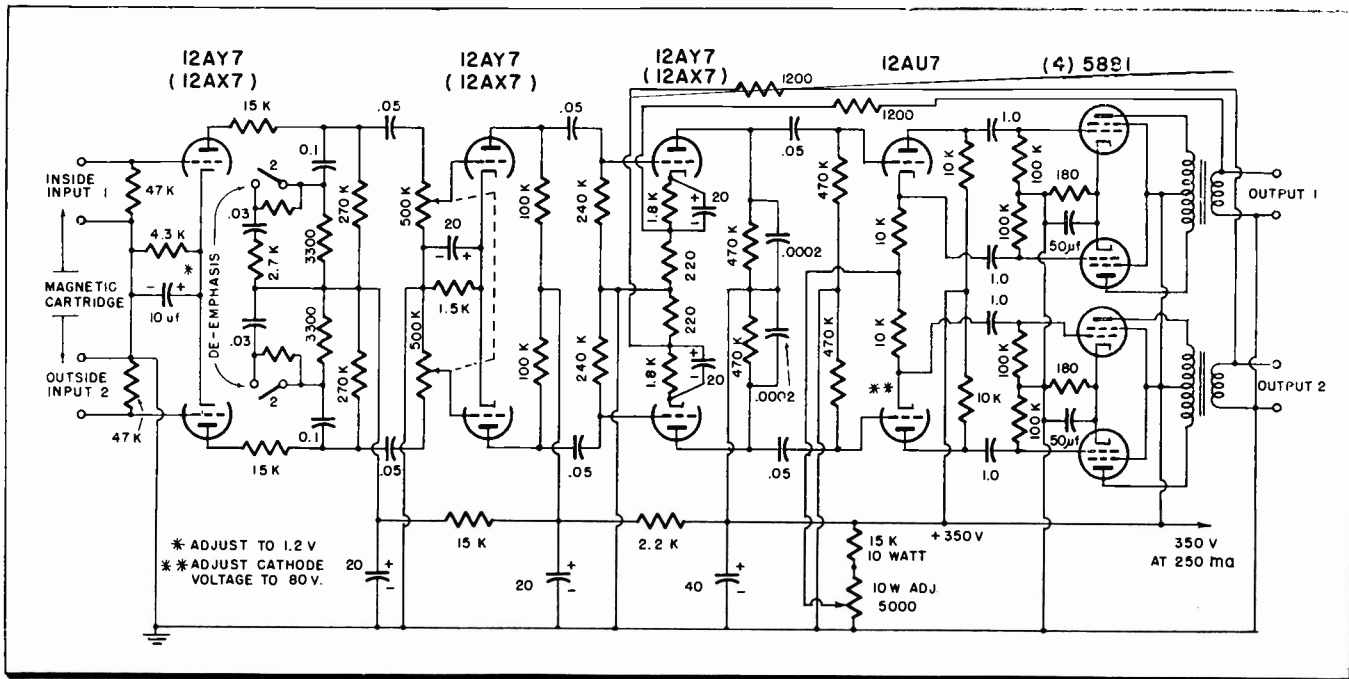

Fig. 3: Complete schematic of high quality binaural amplifying system. Power supply is separate unit

tubes, not including the power supply. No more decoupling or filtering is necessary than with a regular amplifier. The A-B comparison between binaural and monaural on such a minimum system with corresponding small speakers is perfectly astounding, probably because the cheaper monaural systems are so unsatisfactory in themselves. Yet it is hard to see where such an amplifier could cost more than a few dollars extra.

The opposite extreme would be something along the line of Fig. 3, where provision for magnetic cartridges is made, together with phase-splitting so that each output is balanced. Again the increased cost over that of a straight "push-pull" design is very nominal, if one is to

compare it with a regular amplifier using four output tubes as a cost reference.

For equalizing the effective high frequency response of the channels in the room a condenser may be introduced across one or the other of the 220 ohm feedback re-introduction points in the 3rd stage of Fig. 3.

**Test & Alignment**

In addition to the necessity for an adjustment to permit re-setting the 1 1/16-in. dimension should cartridges be changed, there must also be a "fore and aft" adjustment provided so that there is no time delay error between channels,—so that they operate on the same radius. A means for locating to the required accuracy

of 0.01-in. this longitudinal adjustment can be supplied through use of a test record signal. The Cook Series 30 test record is intended as a temporary standard, and in order to be palatable to non-technical users employs a slowly ticking clock as the source. The clock is fed into both channels in parallel simultaneously, in order to provide a synthetic binaural signal. When played on a binaural arm into a binaural reproducing system which has been adjusted for equal gain per "ear," the cartridges in the arm may be adjusted until the clock sound in the room appears to be neither to the right nor to the left, but dead-center. In order to prevent insofar as possible inadvertent errors, the record

Fig. 4: (Left) Photo of binaural tone arm playing back binaural disc. Fig. 5: (Right) Diagram showing how binaural arm is pivoted

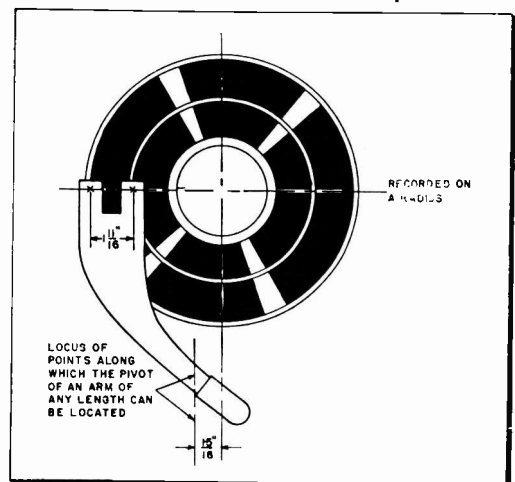

## Binaural Sound

is made not in the 12-in. size, but as a 10-in. disc, where the diameter of start of the test grooves corresponds closely to a zero point in the radial error cycle.

No better method than cut-and-try has been discovered yet for cutter alignment on the recording lathe, and such alignment then has to be done in conjunction with a playback turntable whose adjustment has been made on the basis of the Series 30 record as a standard.

The difference in frequency response between inner and outer diameters of pressings is a subject which is well explored and about which much has been written. Additional pre-emphasis is often and may here be applied at inner diameters to compensate somewhat in advance for translation loss. Unfortunately, there is an engineering proclivity toward making hard and fast rules for "shop practice," to cover all such points as diameter equalization and reference pre-emphasis. The trouble is that rules do not take into account the varying character of program material. The method which is satisfactory for a piano — velocity microphone pickup is not applicable to a bright orchestral picked up with a wide-range condenser. With material which is originally bright there is a severe limit on the amount of effective pre-equalization. Fortunately in a binaural system the two channels are not necessarily matched for frequency response, and in Fig. 3 it will be found that in the de-emphasis circuit (plate) of the first stage of the "inside" channel a 2.7K resistor is used to leave pre-emphasis in effect above about 3300 cps.

A general development probably not too far away is the "half-mil" point which can only be associated with cartridges having extremely low motional impedance. When such cartridges become available in manufacture, the inside-outside range and distortion of LP's in general will be vastly improved, and the binaural translation loss factor will be negligible. As for present practice, it has been found generally acceptable to maintain approximately a 50  $\mu$ s (3300 cps turnover) differential between inner and outer binaural bands in the original recording. Depending upon the program material the outside band might be 50 or 100  $\mu$ s pre-emphasis, and the inner band 100  $\mu$ s or 100  $\mu$ s + 50  $\mu$ s, correspondingly.

Assuming that binaural recordings are pressed in high grade plastic, the most serious surface

noise will be that of ticks and pops. Such noise here, however, will take on a random left-right character and as such is distinctly objectionable because of the directional effect. Hence the recorded level must not be lowered in an attempt to permit full "curve" equalization of bright original material.

When experimental recordings were made using 6-in. microphone spacing and earphone playback, phasing was of course necessary. But contrary to what might at first be expected, phasing of playback speak-



Fig. 6: Close-up of binaural recording shows the two bands of grooves

ers is unnecessary for material recorded indoors (rather than outdoors.) With any spacing of microphones in excess of ear spacing, phase becomes random in view of the acoustics of both the original room and the playback room. However, in playing back material which was recorded in the open, with no confining walls, phasing may well become desirable, especially if the acoustical environment of the playback speakers is on the "dead" side.

By now, most of us are well aware of the fact that a real distinction exists between standard monaural and binaural systems. Any comparison is unfair at the start because the two media are not comparable on any real basis. The extension of the aural medium by addition of dimension, direction and perspective is important not only for vitalizing the musical catalogs we are building but also for extending useful repertoire into fields such as plays and other documents, where the third dimension communicates enough additional information to make the difference between failure and success.

Of commercial necessity we have had to rule out earphones as the playback mechanism, albeit their rigorous binaural nature. We thus descend into a morass of conjecture relating to position of loud speakers, acoustical reflection characteristics of side and back walls, shape of room, etc., all applied to the room in which playback occurs. Here none but the broadest rules may be drawn since even mass-produced living

rooms are decorated and carpeted differently.

In the case of standardization of recording characteristic curves a basic truth was finally recognized, wherein it is obviously both ineffectual and impossible to standardize the recording curve. What we try to standardize is the playback curve only. Thus in developing techniques for binaural recording insofar as microphone placement is concerned, the basic truth must always be kept in mind—that playback (on the average) will take place using 2 speakers separated perhaps 12-15 ft. against a wall in a room of corresponding size and fairly random acoustics.

As binaural disc as a medium develops, there will no doubt be a great deal of expert activity in the realm of "where to put the microphone" and "studio acoustics," and there will be many interim pet theories expounded. Without a conclusive amount of experience at this point, we can only suggest a few directions in which not to go. For instance, the business of about-facing the band on stage and playing into microphones in opposite corners of the stage wings is extraordinarily unnatural in effect. Wall reflections abuse the reality, and treatment of the walls to inhibit reflections pulls the teeth out of the binaural head. The bright synthetic modern studio acoustic appears definitely out from the binaural standpoint. In general, any studio or hall which has been treated with the idea in mind of creating an "even" frequency distribution of energy per square foot,—the "mix 'em up" philosophy,—is lowest on the binaural scale.

And the one unhappy malpractice which has been in vogue for 20 years of broadcast and recording,—that of the small and odd-shaped, acoustically odd and unnatural control room is absolutely fatal for producing binaural. Note is taken of various broadcast and recording company executives who, for very good reasons, insist on listening to their records in an audition room about the size and shape of an "average" living room with similar acoustics. Yet the records are produced and balanced in a studio control room which is about as far away as one could get from the living room prototype, both in size, shape, proportion, acoustics, and relative position in the room of loud-speaker and listener.

For binaural records, it would be better in these control rooms that earphones be used, for making binaural productions will probably become much more of an art than the regular monaural ever was.

# Page from an Engineer's Notebook

## Parallel - Paired Resistance Values

By CHARLES F. WHITE, Electronic Scientist, Naval Research Laboratory, Washington 25, D. C.

Several excellent nomographs exist for the determination of the value of paralleled resistances but for everyday convenience a simple tabulation proves most satisfactory.

The table gives the nominal resistance

for the paralleled combination of two standard  $\pm 5\%$  (gold band) RMA value resistors. This series includes the values in the  $\pm 10\%$  and  $\pm 20\%$  series.

The values for two resistors in the same decade for two resistors in adja-

cent decades are given. Because of the tolerance on the values of the resistors being paired, the actual value obtained physically may deviate by the same tolerance from the tabulated values.

$\downarrow R_1 \downarrow$	100	110	120	130	150	160	180	200	220	240	270	300	330	360	390	430	470	510	560	620	680	750	820	910	1000	$\downarrow R_1 \downarrow$
100	50	52	55	57	60	62	64	67	69	71	73	75	77	78	80	81	82	84	85	86	87	88	89	90	91	100
110	52	55	57	60	63	65	68	71	73	75	78	80	83	84	86	88	89	90	92	93	95	96	97	98	99	110
120	55	57	60	62	67	69	72	75	78	80	83	86	88	90	92	94	96	97	99	101	102	103	105	106	107	120
130	57	60	62	65	70	72	75	79	82	84	88	91	93	96	98	100	102	104	106	107	109	111	112	114	115	130
150	60	63	67	70	75	77	82	86	89	92	96	100	103	106	108	111	114	116	118	121	123	125	127	129	130	150
160	62	65	69	72	77	80	85	89	93	96	100	104	108	111	113	117	119	122	124	127	130	132	134	136	138	160
180	64	68	72	75	82	85	90	95	99	103	108	113	116	120	123	127	130	133	136	140	142	145	148	150	153	180
200	67	71	75	79	86	89	95	100	105	109	115	120	125	129	132	137	140	144	147	151	156	158	161	164	167	200
220	69	73	78	82	89	93	99	105	110	115	121	127	132	137	141	146	150	154	158	162	166	170	173	177	180	220
240	71	75	80	84	92	96	103	109	115	120	127	133	139	144	149	154	159	163	168	173	177	182	186	190	194	240
270	73	78	83	88	96	100	108	115	121	127	135	142	149	154	160	166	171	177	182	188	193	199	203	208	213	270
300	75	80	86	91	100	104	113	120	127	133	142	150	157	164	170	177	183	189	195	202	208	214	220	226	231	300
330	77	83	88	93	103	108	116	125	132	139	149	157	165	172	179	187	194	200	208	215	222	229	235	242	248	330
360	78	84	90	96	106	111	120	129	137	144	154	164	172	180	187	196	204	211	219	228	235	243	250	259	265	360
390	80	86	92	98	108	113	123	132	141	149	160	170	179	187	195	205	213	221	230	239	248	257	264	273	281	390
430	81	88	94	100	111	117	127	137	146	154	166	177	187	196	205	215	225	233	243	254	263	273	282	292	301	430
470	82	89	96	102	114	119	130	140	150	159	171	183	194	204	213	225	235	245	256	267	278	289	299	310	320	470
510	84	90	97	104	116	122	133	144	154	163	177	189	200	211	221	233	245	255	267	279	291	304	314	327	338	510
560	85	92	99	106	118	124	136	147	158	168	182	195	208	219	230	243	256	267	280	294	307	321	333	347	359	560
620	86	93	101	107	121	127	140	151	162	173	188	202	215	228	239	254	267	279	294	310	324	339	353	369	383	620
680	87	95	102	109	123	130	142	156	166	177	193	208	222	235	248	263	278	291	307	324	340	357	372	389	405	680
750	88	96	103	111	125	132	145	158	170	182	199	214	229	243	257	273	289	304	321	339	357	375	392	411	429	750
820	89	97	105	112	127	134	148	161	173	186	203	220	235	250	264	282	299	314	333	353	372	392	410	431	451	820
910	90	98	106	114	129	136	150	164	177	190	208	226	242	258	273	292	310	327	347	369	389	411	431	455	476	910
1000	91	99	107	115	130	138	153	167	180	194	213	231	248	265	281	301	320	338	359	383	405	429	451	476	500	1000
1100	92	100	108	116	132	140	155	169	183	197	217	236	254	271	288	309	329	348	371	397	420	445	470	498	524	1100
1200	92	101	109	117	133	141	157	171	186	200	220	240	259	277	294	317	338	358	382	409	434	462	487	518	545	1200
1300	93	101	110	118	134	142	158	173	188	203	224	244	263	282	300	323	345	366	391	420	446	476	503	535	565	1300
1500	94	102	111	120	136	145	161	176	192	207	229	250	270	290	310	334	358	381	408	439	468	500	530	566	600	1500
1600	94	103	112	120	137	145	162	178	193	209	231	253	274	294	314	339	363	387	415	447	477	511	542	580	615	1600
1800	95	104	112	121	138	147	164	180	196	212	235	257	279	300	321	347	373	397	427	461	491	529	563	604	643	1800
2000	95	104	113	122	140	148	165	182	198	214	238	261	283	305	324	354	381	405	438	473	507	545	582	625	667	2000
2200	96	105	114	123	140	149	166	183	200	216	240	264	287	309	331	360	387	414	446	484	519	559	597	644	688	2200
2400	96	105	114	123	141	150	167	185	202	218	243	267	290	313	335	365	393	421	454	493	530	571	611	660	706	2400
2700	96	106	115	124	142	151	169	186	203	220	245	270	294	318	341	371	400	429	464	504	543	587	629	681	730	2700
3000	97	106	115	125	143	152	170	188	205	222	248	273	297	321	345	376	406	436	472	514	554	600	644	698	850	3000
3300	97	106	116	125	143	153	171	189	206	224	250	275	300	325	349	380	411	442	479	522	564	611	657	713	767	3300
3600	97	107	116	125	144	153	171	189	207	225	251	277	302	327	352	384	416	447	485	529	572	621	668	726	783	3600
3900	98	107	116	126	144	153	172	190	208	226	253	279	304	330	355	387	419	451	490	535	579	629	678	738	796	3900
4300	98	107	117	126	145	154	173	191	209	227	254	280	306	332	358	391	424	456	495	542	587	639	689	751	811	4300
4700	98	107	117	127	145	155	173	192	210	228	255	282	308	334	360	394	427	460	500	548	594	647	698	762	825	4700
5100	98	108	117	127	146	155	174	192	211	229	256	283	310	336	362	397	430	464	505	553	600	654	706	772	836	5100
5600	98	108	117	127	146	156	174	193	212	230	258	285	312	338	365	399	434	467	509	558	606	661	715	783	848	5600
6200	98	108	118	127	146	156	175	194	212	231	259	286	313	340	367	402	437	471	514	564	613	669	724	794	851	6200
6800	99	108	118	128	147	156	175	194	213	232	260	287	315	342	369	404	440	474	517	568	618	675	732	803	872	6800
7500	99	108	118	128	147	157	176	194	214	233	261	289	316	344	371	407	442	478	521	573	623	682	737	811	882	7500
8200	99	109	118	128	147	157	176	195	214	233	261	289	317	345	372	409	445	480	524	576	628	687	745	819	891	8200
9100	99	109	118	128	148	157	177	196	215	234	262	290	318	346	374	411	447	483	528	580	633	693	752	827	901	9100
10,000	99	109	119	128	148	157	177	196	215	234	263	291	319	347	375	412	449	485	530	584	637	698	758	834	909	10,000
$\uparrow R_1 \uparrow$	100	110	120	130	150	160	180	200	220	240	270	300	330	360	390	430	470	510	560	620	680	750	820	910	1000	$\uparrow R_1 \uparrow$

## Eidophor

(Continued from page 31)

(8). The larger the number of bars, the greater is the number of raster elements in a horizontal line. The system should be capable of more than 1000 of these elements per line, which meets all requirements for the time being. The possible number of horizontal sweep lines crossing the parallel light lines perpendicularly which may be included in a raster is almost unlimited, the system having operated satisfactorily at 392, 525, 625, and 729 lines.

Therefore, to project an image on the theatre screen, it is necessary that the output of a TV camera be fed to the electron gun to cause the electron beam to deform the Eidophor liquid in a proper manner which corresponds, element for element, to the original scene viewed. The fact that the liquid deformations retain the image, from which the light is reflected caused the inventor to give it the name Eidophor, derived from Greek sources, meaning image bearer.

### Eidophor Liquid

Examination of the criteria governing the Eidophor liquid indicates that the charges deposited thereon should cause the liquid deformations to remain for one picture period, but to decay rapidly after the period is over. The oil is made conductive to make the deposited charges decay according to an exponential time function. The storage time of the picture is controlled by selecting a liquid of proper conductivity, surface tension and viscosity.

The Eidophor liquid constantly carries an average negative charge which exerts a mechanical force on the liquid. If the liquid film were left to itself, it would eventually be pushed out of area (8). To prevent this, the spherical mirror (7) is slowly rotated to renew the image carrier. A radial knife edge (9) allows the passage of a quantity of the liquid, which has a consistency similar to honey, necessary for the production of the picture carrier.

The liquid and electron gun are placed in a vacuum. In order to keep the pressure to about  $10^{-5}$  to  $10^{-4}$  mm Hg, a continuously operating oil diffusion pump is mounted on the projector. A very low vapor pressure is a prime requirement for the liquid. Furthermore, it must be transparent to prevent any influence on the color of the picture. Since the deformations are dependent on the viscosity, which in turn depends on temperature, a refrigeration unit is

used to assure constant temperature and picture results. Most important, because the system is very sensitive to even the smallest inhomogeneities (maximum liquid deformations are only a few thousandths of an mm), assembly must be accomplished without allowing any foreign particles to enter the optical system, particularly on the oil surface of the spherical mirror.

Unlike ordinary cathode ray tubes, which employ amplitude modulation, Eidophor uses a kind of velocity modulation. To produce the picture raster, 17-kv electrons from a tungsten cathode deposit a periodic distribution of charge along every picture line, the magnitude of this charge being proportional to the brightness of every picture point. The electrons are confined to a constant intensity beam of rectangular cross-section (width 10 to 20% of height), whose height is the width of one picture line. Since the beam intensity is constant at 70  $\mu$ a, variations in charge density deposited on the Eidophor liquid are made by modulating the writing speed. That is, the greater the speed, the less charge deposited to deform the oil, and the less the light is deflected to pass through the mirror slits.

The modulation is produced by superimposing a constant frequency ac voltage on the line sweep voltage. Raster element dimensions are determined by the frequency of this superimposed voltage, while the density of the charge deposited is controlled by the amplitude. Modulation velocity potentials of the order of 1 volt are introduced through separate plates.

The results of a recent U. S. theatre demonstration of the projector indicates that one prime advantage of Eidophor is its ability to produce a high definition color picture of comfortable brilliance. In this showing, a 525-line raster and 8 mc bandwidth were used with the CBS field-sequential color system. The projected picture of the live studio pick-up was bright (about 40 lux in the highlights), had good contrast (1:200), and generally was of excellent quality, almost comparable with color motion pictures. It was noted that Eidophor is also adaptable to a simultaneous color system.

The fine results obtainable with the presently developed model appear to warrant early introduction into American theatres. Work is progressing to improve the projector and to develop an associated film system which will take advantage of several desirable qualities in motion pictures which are not realized in conventional filmed TV programs intended for home reception.

## Sound, No Raster

(Continued from page 9)

zontal hold is varied. If the 15,750-cycle whistle is heard, it means that the horizontal oscillator output tube and transformer are all working. (The whistle comes from the vibration of the horizontal amplifier tube and output transformer). If no spark is present at the HV rectifier plate cap, and whistle is heard, the auto-transformer section of the horizontal output transformer is probably open. In a few sets there is a coupling condenser between the primary and the high voltage secondary that can be at fault also. In any case shop repair is indicated. If the spark is very short but can be pulled out, that is, if we get an insufficient AC spark, the trouble is in the damping circuit. The damping tube should be replaced; if the trouble persists, a shop repair is indicated.

There may be no spark at all at the plate of the horizontal output tube. In that case the trouble may again be in the damping circuit; but before going through the tests just made, the set should be checked for an open fuse in the high-voltage section. This is usually a quarter-ampere, 250-volt fuse located either in the cage, or wired in underneath the chassis. This fuse should be checked and if found open replaced. If the set now works, it should be operated for at least 15 minutes. If the set keeps on working, the customer should be warned that the repair may only be temporary. A thorough shop check is advisable; if the fuse blows again, such a check becomes imperative. In the shop, the easiest method to locate the fault is to short out the fuse and let the smoke indicate the trouble. The set must, of course, not be left unattended. If the spark at the output tube is a DC spark, that is, if it is blue rather than purple and can be pulled out, the horizontal sweep section is defective. This is also the case if no whistle is heard. The horizontal oscillator, the discharge tube and the output tube should then be changed in turn. If the trouble is not cured, an oscilloscope will be of great help in locating the defect

## UHF on VHF TV's

(Continued from page 17)

stubs across which they move. The effect is similar to the resonating of a piece of twin-lead line at different frequencies, if its length is varied.

Two coaxial stubs, one for each pre-selector circuit, is employed. The advantages of using this type of tuned circuit include high selectivity, uniform bandwidth, and good shielding against oscillator-radiated signals.

The 6AF4 oscillator uses a section of parallel-wire transmission line for its tuned circuit. The line is shorted at one end. A moveable shorting bar moves across the line, varying its tuning.

The symbols indicate that inductive or link coupling is used between the antenna and first preselector circuit; also between the first preselector and the

second one (mixer input circuit). Coupling between the oscillator and mixer is capacitative.

The cascade first IF amplifier is tuned to a center frequency of 25 MC, and has a broad bandwidth (app. 7 MC). Coupling from the cascade first IF amplifier section to the VHF input is through a ten-inch length of coaxial cable.

Oscillator grid current, rather than grid voltage, is measured in this circuit (as well as in other UHF oscillator circuits). A suitable terminal is provided for opening the UHF oscillator grid circuit at its ground side. When the current flowing in this circuit has been measured with a sensitive enough milliammeter, the grid voltage may be obtained by multiplying the current figure (in amps) by the grid resistance (in ohms). The oscillator grid voltage is not measured directly because the voltmeter, even when it uses a shielded and isolated probe, and is vacuum-tube in type, is apt to detune the oscillator when it is connected at the grid.

Another converter circuit (Stromberg-Carlson UHF Television Converter) is shown in fig. 5. Space limitations and economy factors make the use of a selenium rectifier preferable to a vacuum tube. A power transformer is employed to eliminate the setting up of hum potentials between the converter and the TV receiver. The transformer also isolates the chassis from the line, preventing the chassis from being "hot."

The filaments of the converter's tubes remain on during both VHF and UHF reception; B+ voltages are, however, removed from the converter's filter condenser during VHF operation by a switch in the ground return of the power transformer secondary.

Provision for connecting in a separate UHF antenna has been made at the rear of the chassis.

The converter may be operated on either channel 5 or 6, provided that the channel selected is not occupied by a local station. A switch at the back of the converter chassis makes the desired choice, shifting the tuning of the first IF stage by 6 MC. Since the bandwidth of the pre-selector circuits is 12 MC, the switch from one channel to the other can be made without losing tracking or cutting sidebands.

The tuning units in the antenna and mixer circuits use inductive-type padding to obtain the correct tuning range. The padding is obtained by making the two conductors in the antenna tuning section, and one conductor in the mixer tuning section, extend  $\frac{3}{8}$  of an inch beyond the tuning unit. The 300-ohm balanced line is coupled through an ungrounded loop into the extended section of the tuning unit.

To help obtain the desired 12 MC bandwidth over the entire UHF band, a combination of capacitative and inductive coupling is employed between the antenna and mixer tuned circuits.

In the oscillator section, a series trimmer helps establish the low-frequency end of the tuning range. The extent of the tuning range, as well as the upper limit of this range, is determined by a series trimmer inductance made up of the grid and plate leads. Varying the

spacing of these leads regulates the adjustment of this inductance.

To avoid "holes" in the bandpass, resistors are used in place of chokes in the plate and grid return circuits. Dissimilar chokes are used in each heater leg for the same reason.

The oscillator tube socket is a special low-capacitance type used to minimize the effect of the grid-to-plate socket capacitance on the tuned circuit. "Warm-up" oscillator drift is minimized by use of minimum plate voltage. Oscillator radiation is reduced not only by complete and careful shielding, but by using a low value of oscillator plate voltage.

The pre-amplifier, or 1st IF amplifier, is cascade in type. The output triode of the double-triode 6BQ7 has a 6 MC bandwidth. A switch on the rear of the chassis selects the desired VHF channel. For reasons of economy, the switch employed is a simple slide unit that regulates the amount of capacitance in series with the B+ end of coil L-9, and thus controls the latter's tuning.

The secondary of L-9 is balanced to ground, to eliminate the pick-up of interference that might occur if a single-ended input to the VHF receiver was used.

## Servicing AGC

(Continued from page 21)

tive point in the brightness control circuit. The positive voltage fed to the plate is changed to a negative one by the conduction of the delay tube.

-2.4 V is fed to the AGC-controlled RF amplifier in the presence of weak signals. Approximately 0 volts is fed to the controlled video IF stages at this time. (Practically all of the -2.4 V AGC voltage is used up across R-155 and R-156, very little remaining across R-158 to be fed back to the video IF stages.) Thus, some negative voltage is developed and fed to the RF stage, but practically no AGC voltage is supplied to the video IF stages, when weak signals are coming in.

In the presence of medium and strong signals, the positive signal voltage fed to the grid of the AGC amplifier overcomes the negative cut-off bias, and the tube conducts, producing an AGC voltage.

If the AGC delay tube becomes defective, weak signals may not be satisfactorily received, since the reduced bias of the RF amplifier may cause enough signal to be transferred to the AGC amplifier to prematurely bring it out of cut-off and produce an AGC bias at the grids of the controlled video IF stages.

An AGC threshold control is present. It is adjusted with weak signals coming in, and is set to a point where the receiver just begins to overload when the contrast control is advanced to maximum.

Servicing of this circuit is similar to that of the other circuits discussed. A scope can be used to check plate and grid waveforms. If these waveforms are absent, incorrect in amplitude or imperfectly shaped, the circuit points between plate and grid and the source of

each waveform can be scope-checked, to help find the source of the trouble.

When scope tests are inconclusive, DC voltage and resistance tests will prove helpful.

## UHF-VHF Circuits

(Continued from page 15)

tenna (actually radiated), avoiding standing waves of input circuit noise at the first tuned circuit.

Thus far we have discussed some of the requirements of composite VHF and UHF receivers. Let us now consider UHF reception on standard VHF receivers.

### Converter Design Considerations

Of necessity, a UHF converter must operate with a different intermediate frequency than that of the associated VHF receiver, otherwise it would be necessary to make actual wiring changes in the VHF receiver.

Utilization of the double superheterodyne principle is forced upon all designers of UHF converter units in order that the output signal may operate into one of the standard VHF channels. The choice of the channel could be fairly broad, extending from channel 2 to channel 13. This choice determines the frequency of the pre-i-f (or VHF) amplifier; the latter, incidentally, provides separation between the UHF mixer and the VHF receiver, as well as signal amplification.

It has been found that there is an optimum range of frequencies for this pre-i-f amplifier. The frequency must be less than  $\frac{1}{2}$  of the lowest UHF channel, or the spurious responses from harmonics of the local oscillator may be quite serious. This places the maximum usable i-f frequency below channel 7, and, for the vast majority of conventional VHF receivers, leaves the highest frequency choice as channels 5 or 6, or 76 to 88 mc. As you know, it is necessary to have a choice of two channels so that in a given location, the VHF receiver may be switched to the one, either 5 or 6, which has the lowest VHF interference.

Due to the simultaneous use of two local oscillators, one in the converter, the other in the VHF receiver, very careful shielding of the converter assembly is essential to reduce interference possible from the harmonics of one local oscillator beating with the harmonics of the other, together with harmonics of the intermediate frequencies. In addition, a high-pass filter at the input to the tuner section and a low-pass filter at the pre-i-f output of the converter are desirable.

## Sync Stages

(Continued from page 29)

age depends on the ratio of the plate resistances of the 1st video amplifier and the 1st sound IF tube, since these tubes are connected in series, and the gate tube cathode is connected into this series line at a point between the two tubes.

With its cathode at +125 V and its grid at B+ potential, V13 conducts heavily, developing an AGC voltage in its output circuit. The gain of the receiver is consequently reduced; the 1st video amplifier comes out of cutoff, and plate current flows through it, reducing its plate voltage, and consequently making V13's grid less positive. V13 now conducts less, and the AGC voltage does not increase as much in this interval as in the preceding one. The action continues until the point of stabilization is reached. At this equilibrium point, the AGC gate tube is operating with its bias just above cutoff.

Under these conditions, the sync tips of the composite video signal fall 15 V below the B level (see fig. 4). Noise pulses with an amplitude of 15 V in excess of the sync tips can therefore be developed in the plate circuit of the video amplifier. (Negative noise pulse peaks at the input of the video amplifier cannot drive the plate voltage above the B level; this level therefore constitutes the upper ceiling for noise pulses.)

This is the state of affairs that would exist if the AGC gate tube was not connected into the video amplifier. Its presence in the circuit, however, changes matters. The cutoff level of the AGC gate tube is a negative 5 V. In other words, if a 5 V. drop appeared across R305, and R215 and R217 were absent (with the upper end of R305 connected to the V13 grid), the AGC gate tube would cut off—an undesired condition, since the receiver would overload in consequence.

Now, the larger the negative-going sync pulse input applied to the 1st video amplifier, the greater becomes the negative bias of the amplifier, and the smaller is the voltage drop across R305. To avoid more than a 5 V. drop across R305, the sync pulse to the video amplifier would have to be so large that the sync pulse output in the plate circuit would fall only five volts below the B level. Noise pulses only five volts greater in amplitude than the sync tips could, in consequence, be developed in the 1st video amplifier output.

The sync pulses must be reduced 10 V further below the B level, to allow noise pulses to exceed them sufficiently in the 1st video amplifier plate circuit. Now, the level of the sync pulses in this circuit is determined by the input to the video amplifier; this is, in turn, determined by the gain of the AGC-controlled stages. By suitably adjusting the level at which the AGC gate tube conducts, the distance from the sync tips to the B level can be made correct.

The result desired is achieved by inserting the R215-R217 voltage divider into the grid circuit of V13. A ten volt drop occurs across R215. This ten volt drop (which tends to make the V13 grid ten volts more positive) is in series with the five volt drop across R305, as far as the V13 grid is concerned. A total negative voltage of almost 15 V. may now be developed across R305, without cutting V13 off and upsetting receiver

operation, since the 10V positive voltage across R215 will buck the (app.) fifteen negative volts developed across R305, reducing the net bias applied to V13 to -5 V (the maximum it is meant to handle). Noise pulses approximately 15 V in excess of the sync pulses can now be developed in the 1st video amplifier plate circuit, and fed to the gated leveller.

In troubleshooting the inverter, a scope is very useful. Connect the scope vertical input between cathode and ground of the inverter. Noise pulses should be seen (fig. 5A), if the circuit is functioning normally, and appreciable noise pulses are associated with the incoming signal. If no noise signals are seen at the cathode, but the contrast of video information on the CRT screen seems normal, try another noise inverter tube. If the noise signals still do not appear at the cathode, volt-ohmmeter checks in the circuit should rapidly locate the trouble.

For a check of the AGC gate circuit, inspect the waveform at pin 4 of the gate-pulse plug (see figs. 5b, 6). This waveform should be an approximately 500 V peak-to-peak pulse with a frequency of 15,750 cycles. The waveform on the grid of V13 (fig. 5c) should be the composite video signal, approximately 22 V in amplitude, checked with the scope frequency setting at 60 cycles.

When trouble is to be isolated in the AGC gate circuit, the remainder of the receiver may be made to function normally by applying a fixed bias to the AGC bus of approximately -7.5 V. Voltage tests can then be accurately made. Keep in mind that the gate tube derives its bias from the voltage divider made up of the 1st video amplifier and 1st sound IF amplifier connected in series. Trouble in either of these circuits can cause the wrong bias to be delivered to V13, upsetting its operation, as well as that of the circuits associated with it.

## Cascode Circuits

(Continued from page 23)

decoupling network. C120 is a small neutralizing condenser.

Interestingly enough, feedback in this stage is employed, not to prevent regeneration, but to boost the gain. The plate impedance of the first tube is essentially capacitative, causing feedback to be *degenerative* in nature (compared with the *regenerative* feedback that would tend to occur in such a tube if a tuned plate circuit were present). If this degenerative plate-to-grid feedback were not counteracted, reduced gain would result, lowering the signal/noise ratio.

C116 puts the grid of the second triode at RF ground potential—a necessary condition for grounded-grid operation. Since the two triodes are in series across the B supply (see fig. 6), the cathode of the second triode (V-2) is positive to ground—125V positive, to be more specific. The grid of V-2 must similarly be positive, although less positive than the cathode, for

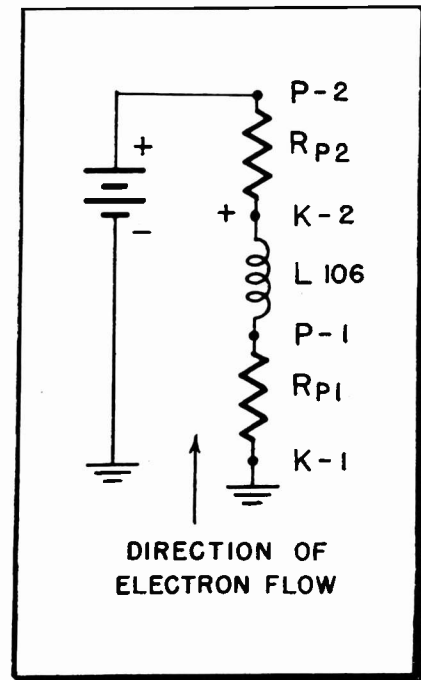

Fig. 6—Simplified, equivalent circuit of the two triodes shown in fig. 5. K-1, R<sub>P1</sub> and P-1 are, respectively, the cathode, plate resistance and plate of the first triode; K-2, R<sub>P2</sub> and P-2 are the cathode, plate resistance and plate, respectively, of the second triode. Note that the cathode of the second triode is positive to ground.

proper biasing. Voltage-dividing components R111 and R112 cause a positive voltage to be established for V-2's grid that makes it negative to its cathode by the necessary voltage.

An AGC voltage is applied not only to V-1, but to V-2 as well. If the AGC voltage of V-1 tends to go up, the plate current of both tubes tends to go down (since the same plate current flows through both). The plate resistance of both is thus effectively greater. A larger plate-to-cathode voltage is now developed across the larger plate resistance of V-2. Since V-2's grid voltage is fixed by the ratio of R111 and R112, the increase in cathode voltage increases its grid-to-cathode voltage, increasing the bias. Thus, AGC is effective at V-2 as well as V-1, preventing overloading when strong signals are coming in.

R110 is inserted between cathode and grid of V-2 to reduce the effect of—i.e., “delay”—the AGC applied to V-2 at low signal levels. It is desirable to keep the AGC voltage minimum when the signal input is low, to avoid a reduction of the signal-noise ratio. When the AGC voltage tends to boost the bias of V-2 by increasing V-2's cathode voltage, current flows between V-2's grid (less positive or more negative point) to V-1's cathode (more positive point). This current flows through R111, causing the grid (to ground) voltage of V-2 to go *more positive*. The tendency of the AGC voltage to make the grid go *more negative* is thus partially counteracted. R110 has little effect at high signal levels.

# Noise Eliminator

(Continued from page 27)

arises when the set is out of horizontal synchronism. The keyed AGC system cannot function correctly in such a case. Adequate AGC bias is not developed, and excessive signal may consequently be applied to the video amplifier. The sync pulses at the input to the noise inverter may be large enough under such circumstances to trigger V14B, causing the sync pulses to be inverted, and thus preventing them from pulling the set into synchronism. To prevent such an undesired action, anti-lockout components are inserted into the circuit.

C48 and R67 form part of the anti-lockout system. When the receiver is out of sync, V14B conducts during sync pulse time, and C48 tends to be charged up by the vertical sync pulses, since these are of sufficiently long duration to do the job. The voltage developed across C48 reduces the plate voltage applied to V14B, as it is opposite in polarity to the B voltage applied to the plate.

The plate voltage is reduced so much, in fact, that V14B stops conducting, and therefore ceases to invert sync. V14B will start to conduct again as soon as enough of the charge present on C48 has leaked off (through R67) to raise the plate voltage to the conduction level. Due to the relatively long time constant of C48 and R67, however, enough time is taken by C48's discharge to permit the receiver to come into sync. When it does so, the sync pulses will no longer be large enough to improperly trigger V14B, since the AGC voltage will be high enough to prevent such an action.

## Anti-Lockout Measures

Another anti-lockout measure is provided by connecting R70 between the video detector output and V14B control grid. The negative DC voltage output of the detector becomes quite large when the receiver is out of sync, since the AGC system is not biasing the IF controlled stages properly. This large negative bias, when fed back to the V14B grid, will help prevent it from conducting on sync pulses, and thus locking the receiver out. When the set is functioning normally, the negative DC voltage output of the detector is too low to interfere with V14B's operation.

A third anti-lockout measure consists of using such values for C47 and R70, that their time constant will be correct. This can be explained as follows: V14B tends to conduct on sync pulses when the set is out of sync, as described previously. The large-amplitude, long-duration, positive-going vertical sync pulses present at the grid tend to cause grid current to flow. If the C47-R70 time constant is right, the grid current flow will rapidly build up a charge on C47 that will leak off slowly. This charge will maintain a negative voltage between the grid of V14B and ground that will bias V14B back. The increased negative bias on V14B (due to grid current flow, long R70-C47 time constant,

and connection of the V14B grid to the video detector output) as well as the reduced V14B plate voltage (due to the long time constant of C48 and R67) quickly cuts V14B off when it starts to conduct on sync pulses, eliminating the possibility of lockout.

Some readers may wonder if a transfer of negative noise pulses through R64 to video amplifier plate resistor R63 may not occur, with undesirable consequences—i.e., production of white noise, as well as attenuation of any positive-going video signals present at the time. The answer is that negative noise voltages are so greatly attenuated by R64, that they are insufficient to overcome the black (positive) noise put out by the video amplifier. In other words, the CRT scanning spot is black when noise is present, just as it would be if no noise inverter were used in the set.

## Lightning Protection

(Continued from page 35)

on 120 v. ac branch circuits to protect low rated electronic equipment. This protector consists of a .600 in. carbon block discharge gap in series with a silicon carbide varistor.

Fig. 6 shows a two-section varistor assembly and two carbon block discharge gaps which will provide low voltage protection for two 120 v. branch circuits. These components may be arranged in various ways to facilitate mounting in the radio cabinet. The varistor prevents 60 cycle power-follow and the small resistance introduced by it materially extends the life of the gap. These low voltage branch circuit protectors should be installed in the radio equipment cabinet on the line side of the fuses.

In this location the device will not only protect the equipment from dielectric breakdown, but will reduce the possibility of equipment fuse operation on surges.

It is also recommended that time delay type fuses or circuit breakers be substituted for the branch circuit power fuses on circuits equipped with the low voltage varistor protector. Tests indicate that a higher level of protection will be secured if there are at least several feet of iron conduit between the service entrance and the location of the low voltage protector. Considerable benefit can be derived from the impedance introduced from such conduit as shown in Fig. 5.

The power protection just discussed is intended primarily for the protection of the station equipment. At locations where no provision is made for standby power service, it is desirable to consider the adequacy of the protection on the power line itself. The multi-grounded neutral

power circuit usually provides a low resistance path to earth on the neutral and in combination with the station ground provides a grounding system that can be of considerable mutual benefit. Power systems, however, which do not provide some path for surge current between primary and secondary neutrals are more likely to be damaged by lightning. As a result of a stroke to either the power line or the station, a potential will appear between the primary and secondary windings of the distribution transformer serving the station that may damage the windings and interrupt service.

Fig. 5 shows a particular power connection at a radio station where the distribution transformer was damaged by lightning. It may be noted that interchange of surge current between the station ground and power primary neutral grounds would create arcing in the transformer. Interconnection between primary and secondary neutrals or between the primary arrester ground and the secondary neutral is desirable. In the case shown in Fig. 5, interconnection may be by means of a discharge gap between the primary arrester ground and the secondary neutral as shown in the figure.

The problem of protecting the fixed stations of a mobile radio system from service interruptions due to lightning is not confined to the station equipment and the antenna system, but consideration must also be given to the connecting power and land communication facilities. The protection methods discussed have been successfully employed in Bell System radio installations and many of the arrangements will also provide satisfactory protection for other types of equipment.

Associated with the technical solution of a protection problem is the matter of cost. The amount of protection applied should be determined through a consideration of the probable savings in plant damage expense and the value placed upon continuity of service.

## SHOP HINT

### Record-Changer Service

When a record-changer is serviced outside the receiver cabinet, and the female motor plug connector to the line is not available, try the cheater cord of a TV receiver on for size. It often fits. The male end of the cheater goes, of course, to the AC power outlet.—Sol Sukenick, 5160 Arbor Street, Phila. 20, Pa.