

Theodore E. Rose
Editor

J. F. Thompson
Associate Editor

J. B. Straughn
Technical Editor

L. L. Menne
Editor Emeritus

NRI NEWS

VOL. 18, No. 12

December-January, 1959-60

Published every other month by the National Radio Institute, 3939 Wisconsin Ave., N.W., Washington 16, D. C. Subscription \$1.00 a year. Printed in U.S.A. Second class postage paid at Washington, D. C.

Thomas Hull of N. Y. Is President-Elect NRIAA for 1960

Page 27

COLOR TV—What's it Doing?

We might say the answer to this question depends on who's talking. Herbert Riegelman, General Manager of the General Electric TV Receiver Department says: "Color TV's potential at its present level of technological development is of such questionable consequences and of such great risk to our distributor and dealer organization, we do not feel justified in jeopardizing our monochrome position simply to be able to say that we are in the color TV business . . . color TV is not off the ground."

But we also have Jack S. Beldon, Vice Pres. and General Manager, RCA Victor Home Instruments who says: "Every indication points to a thriving market in color TV as well as black and white." *Electronic Technician.*

Transistor Receivers Their Troubles and Remedies

By

J. B. Straughn

Chief, NRI Consultation Service

Let's explore the differences, from a servicing viewpoint, between the transistor receiver and the AC-DC or three-way portable tube receiver. If of recent origin, both types of sets will often use etched or printed circuitry. If you are unfamiliar with the repair of etched circuit equipment, refer to the article on this subject in the October-November issue of the *NEWS*. A limited supply of reprints is available.

Unlike tubes, transistors are often soldered into the circuit although some receivers use special sockets into which the transistor leads are inserted. Contrary to public opinion, transistors do fail and when suspected they must be removed for testing in a transistor checker, or by substitution of a new transistor.

The actual difficulties encountered in transistor sets are, in general, the same as those in tube receivers. Power supply difficulties

(Page two please)

The Season's Greetings

WITH BEST WISHES FOR THE NEW YEAR



J. E. SMITH and N. R. I. STAFF

Transistor Receivers

are quite different because the transistor set uses a single low voltage battery while the three-way portable operates from the power line or uses an A battery for filament supply and a B battery to furnish power to the plates and screens.

If the A battery voltage drops only a small amount the tube receiver will be dead. Transistor sets, on the other hand, are generally designed to operate down to $\frac{1}{2}$ of the original battery voltage. However, low voltages in a transistor set can cause various troubles and full supply voltage must be used when servicing. More on this later.

Because both the input and output impedance of a transistor stage is low, there will be no stray AC pick-up. Because of this and, since transistor sets do not operate from the power line, hum is not a problem. Other symptoms however are familiar to anyone who has serviced tube receivers. Both types of sets use the super-heterodyne circuit. Thus in a transistor receiver you will find an antenna, usually of the loop-stick variety, which is tuned by one section of the tuning capacitor. The signal across this resonant circuit is applied to the input of the mixer stage.

More often than not a single transistor works as a combination mixer oscillator, although, like some tube receivers, a separate oscillator stage is sometimes used. Special cut plates on the oscillator section of the tuning capacitor are a rarity. Like the very old tube receivers, the rf and oscillator sections of the gang are usually identical in shape. In most cases the oscillator section may be somewhat smaller (have less plates) but the plates of the two sections will have the same shape. This means that tracking of the mixer and oscillator circuits is accomplished by a low frequency oscillator adjustment. In tube receivers this was done with a padder capacitor. Transistor sets invariably use powdered

iron oscillator cores and the core position in the coil is adjusted at the low frequency end of the dial. This serves the same purpose as a padder capacitor and insures proper tracking over the broadcast band.

The output of the mixer is fed into the i-f amplifier which is tuned to the predetermined i-f frequency. As in a tube receiver, 455-kc is most often used for the intermediate frequency. It is seldom that a modern tube broadcast receiver will use more than a single i-f amplifier stage. Transistor sets commonly use two i-f stages although some employ only one stage. A two-stage i-f amplifier will have three i-f transformers while a single stage will use two transformers (an input and an output.)

The i-f amplifier will feed into the second detector which strips the modulation from the i-f carrier. In tube receivers a diode section in the first af tube is ordinarily used as the second detector. In a transistor set the second detector is usually a germanium diode—sometimes, but it is rare, a transistor is used for this purpose.

In both tube and transistor sets, the volume control is generally used as the diode load resistor, across which the avc voltage is developed. In a tube receiver the volume control has a high impedance, its dc resistance being anywhere from 250,000 ohms to 2 megohms. In a transistor set the volume control resistance may lie between 1500 ohms and 10,000 ohms. In a tube receiver you will hear a buzz in the speaker if you touch the slider of the volume control. Due to the low impedance of the transistor volume control, nothing will be heard if you touch its terminals.

A tube set will almost invariably use a first af stage. In a transistor set the second detector diode load (volume control) may be coupled directly into the power output stage and from there to the loudspeaker. In the larger transistor sets, or where one stage of i-f amplification is used, there will be a stage of audio amplification between the volume control and power output stage.

In the audio system either R-C or transformer coupling will be used between audio stages. Transformers are always used in portable sets to match the speaker voice coil to the output transistor.

Because of the low input and output impedance of the stages in a transistor receiver, electrolytic capacitors are used in
(Page four please)

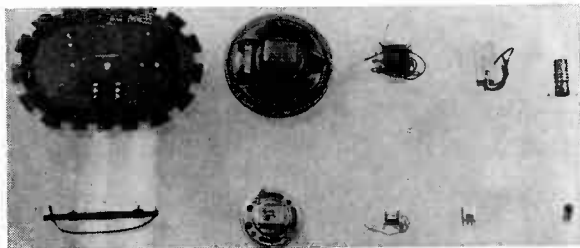
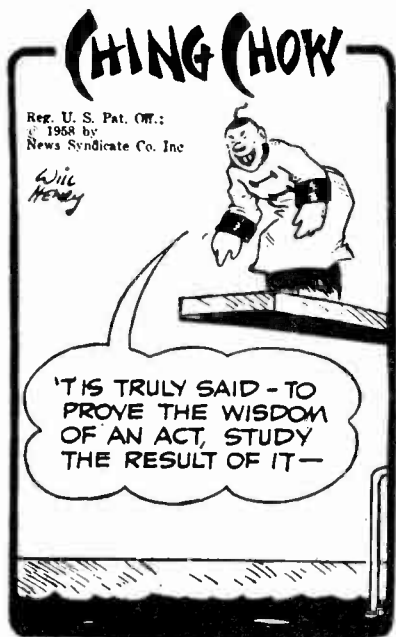

Fig. 1. Shown above, as a means of comparison, are some typical parts found in a tube-type receiver, top row, and a transistor receiver, bottom row. These parts are, left to right, antenna, speaker, audio output transformer, i-f transformer, and oscillator coil.



— n r i —

“The man who knows how will always have his job; the man who knows why will be his boss!”

—National Business Publications

— n r i —

Who Sent This Payment?

American Express Money Order CH-202, 219,278 for \$8 dated October 17, 1959 and stamped “1516 FITCH FURN” (probably the place where it was bought).

The money order reached us in a National Radio Institute student return envelope postmarked “Indianapolis, Indiana, October 19, 1959” The sender failed to identify himself in any way—he neglected to write his name on the money order, or enclose any identification. There was no name or address on the envelope.

We’d like very much to credit this \$8 to the account of the student who sent it. He’ll probably be very annoyed when his next statement fails to show that credit. But until we get some word from the student to identify himself, it will be a *mystery payment*.

Please—whoever sent this money order—write *at once* and tell us.

The Biggest Day of Your Life

Most people want to do big things. They dream of the day when their real powers will blossom forth in all their glory, and something big will be done.

The great trouble about waiting to do the big things is, the years are piling up and nothing is being done.

The day is not far away when one’s powers to accomplish will be unequal to one’s ambitions, and the dream will remain a dream—unfilled and unattained. To sit by the dead embers of unrealized dreams is poor comfort for the years to come, and a sad commentary upon one’s record of aspirations and achievements.

The big things can be done by most of us who dream in terms of successful accomplishment.

How? It doesn’t take a prophet to disclose the secret. Just ordinary sense and understanding of life will point the way to achievement—DO IT TODAY.

Do the little things that lie in our way that must be done—do them NOW, for the little things well done are the foundations of the bigger things we crave to do. Success is but the accumulation of little things faithfully done.

Today is the most momentous day in your history—it will not come back. Give tomorrow a chance by doing today’s work today. IT’S YOUR BIGGEST DAY.

— n r i —

Index

Article	Page
Transistor Receivers, Troubles and Remedies	1
Modern Substitution Boxes	5
Christmas Suggestions	16
Introducing Two All-New NRI Professional Instruments	20
Hi-Fi Corner	25
NRI Alumni News	27
Directory of Local Chapters	31

Transistor Receivers

(Continued)

coupling networks. The familiar electrolytics however, are not suitable. Their leakage currents are so large that the bias on each stage would have to be individually adjusted to compensate for the leakage of the particular capacitor used. Instead, tantalum electrolytics are employed. These capacitors have low leakage current in addition to being physically very small. Their leakage resistance will usually be as high as that of a good paper or ceramic by-pass.

Of all the parts used in a transistor set only the resistors will be of the same size as those in the receivers. Fig. 1 shows a number of parts used in tube receivers and their counterparts found in transistor sets.

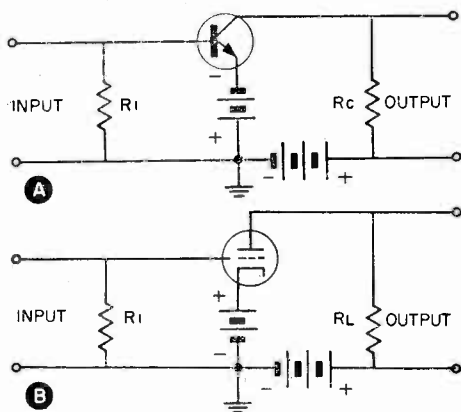

Figure 2a

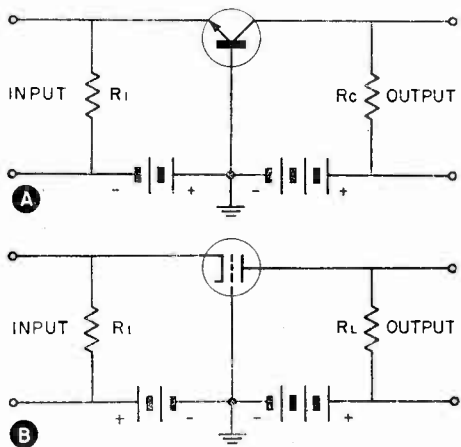

Figure 2b

To service a transistor receiver you should be familiar with the operation of the various stages. You should also be able to identify the input and output of each stage by looking at the schematic. The three types of circuits you will encounter with their tube counterparts are shown in Fig. 2. You must also understand the biasing methods employed in all stages.

To quickly service any receiver you will find it extremely helpful to have a copy of the service information. This will contain a schematic and, in many cases, a pictorial of the etched circuitry showing the location of parts. Typical operating voltages are given as well as alignment information and basing data on the transistors which will enable you to locate the collector, emitter and base leads of each transistor. These correspond to the plate, cathode and control grid of a triode tube. You must be able to identify these points for voltage and continuity tests and for connection points in making defective stage localization tests.

While there is little standardization as yet in the basing of transistors the usual base layouts are shown in Fig. 3.

The same type of component troubles occur in both tube and transistor receivers with the exception of the tubes and transistors. You will find that oscillator and loop coils open up and also develop shorted turns or absorb moisture, thus reducing the coil Q. Transformers of the audio and i-f variety develop similar troubles. Re-

(Page 14 please)

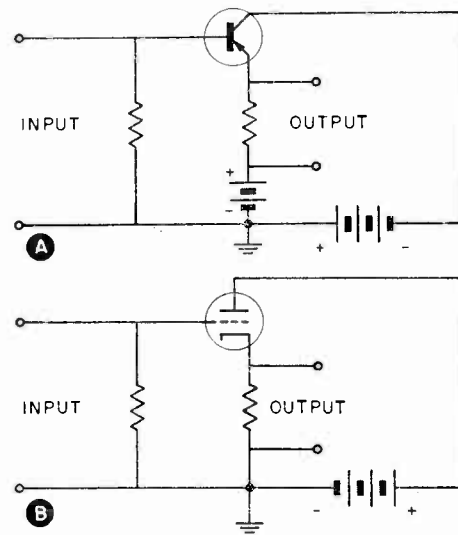

Figure 2c

Modern Substitution Boxes

Reprinted by courtesy of Cornell-Dubilier Electric Corp.

THE SUBSTITUTION BOX has a long history of usefulness in electronics. The resistor box came first and was followed quickly by the capacitor box. They took their cue from the resistance and capacitance decade boxes of the laboratory. Approximately one generation of technicians has used those two units. From time to time, substitution boxes of other types were devised by experimenters for their own purposes and were publicized but not commercialized.

There are two ways of using a substitution box: In troubleshooting, it can be substituted for a damaged or missing component (and this is how it got its name); or in circuit development work, it can be used to determine the best value for a component. In the first instance, use of

is provided. One type of substitution box provides separate types of components. Examples of this kind are diode and transistor boxes.

The progress of modern electronic bench work is speeded by substitution boxes of many sorts, some of which are not yet familiar to all technicians. Components of virtually every kind, and networks as well, are switched in these modern boxes. It is interesting to note that transistor substitution boxes have provided the first example of active-component switching. (Vacuum tubes seem to have been neglected in this technique, perhaps for the reason that the tube is an easily-substituted plug-in component itself. Not all of the modern substitution boxes have been exploited commercially.



Substitution-Box Philosophy

In order successfully and economically to apply the principle of component substitution, the basic philosophy of the substitution box must be considered. The box principles remain substantially the same regardless of the type of component that is switched.

In any substitution box, the components are accessible electrically through either separate terminals (such as binding posts or panel jacks) or through a rotary selector switch. The advantage of a switch is that its use obviates shifting leads externally. However, separate panel terminals for the components are desirable when current levels are too high for a small switch, or when the stray capacitance of a switch would be troublesome.

the substitution box allows the equipment under test to be restored immediately to operation so that tests may be made. In the second instance, use of the box obviates many calculations or the soldering and unsoldering of many separate trial components.

The mathematical theory of switching might be invoked to analyze the substitution box and to determine its optimum arrangement. However, this approach is beyond the scope of this article, since most of our readers lack the necessary mathematical background. Instead, the principal configurations of substitution boxes will be shown. These illustrations will serve to answer the question as to how many ways are available for connecting the components inside a substitution box and which is the best way. The principal configurations of substitutions will serve to answer the question as to how many ways are available for connecting the components inside a substitution box and which is the best way. The principal configurations are shown in Figures 1, 2, and 3 and are dis-

The utility of the substitution box is due to its adjustable nature. Usually it provides various values of a component in steps obtainable either through a selector switch or a series of terminals. In some instances, however, such as potentiometer or variable capacitor boxes, continuous variation, as well as step-type selection,

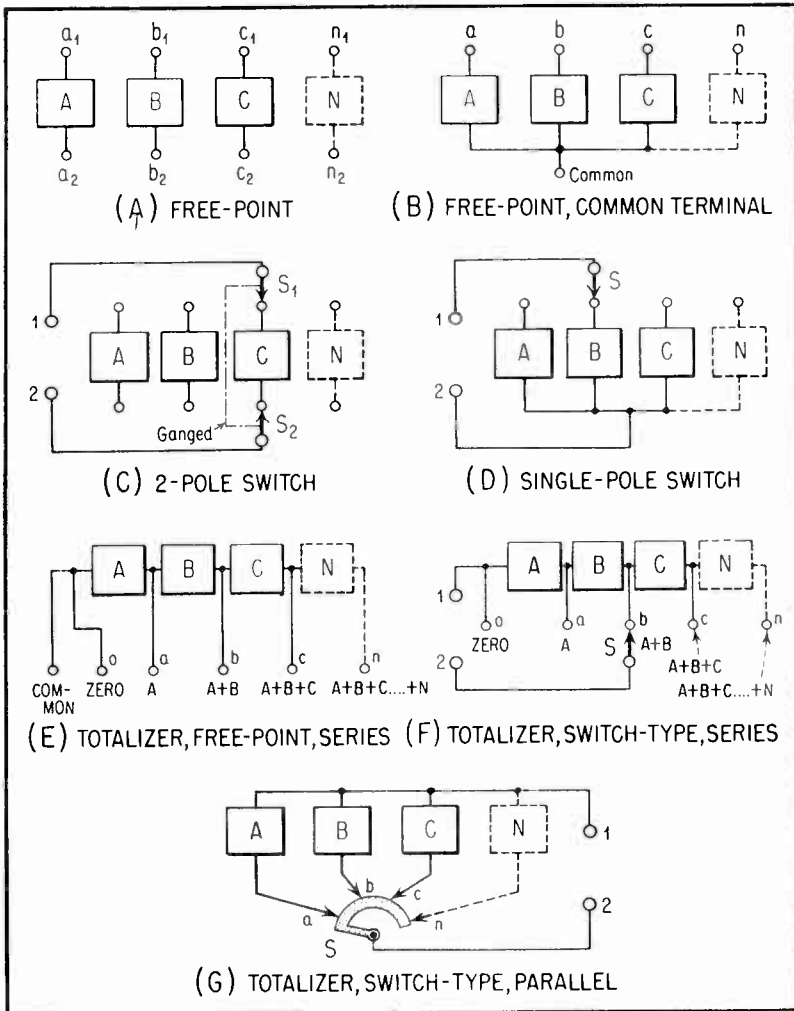

Fig. 1. 2-Terminal Configurations.

cussed in the following paragraphs. In each example, components are represented by blocks, each having the proper number of terminals. The number of components may be extended up to any desired practical limit. The block labelled N represents the nth component in such a series.

2-Terminal Configurations. Examples of 2-terminal units are capacitors, resistors, inductors, diodes, rectifiers, varistors, thermistors, rheostats, varactors, and choke coils. In addition to these single components, two or more such components may be connected in series or parallel to form a network and each such assembly would have two terminals. Figure 1 shows the methods of connecting 2-terminal components.

When both terminals of a component must be separately available, 1(A) or 1(C) may be used. In figure 1(A), the components are connected between two rows of panel terminals, a_1, n_1 , and a_2, n_2 . External connections are made directly to these terminals. In Figure 1(C), a 2-pole switch (S_1S_2) is provided for selecting the pairs of component terminals. External connections are made to a single pair of panel terminals (1 and 2).

In many instances, both terminals of each component need not be available separately. Here, one lead of each component may be connected to a single COMMON terminal on the panel, and the opposite leads to separate terminals, as shown in Figure 1(B). The saving in panel terminals af-

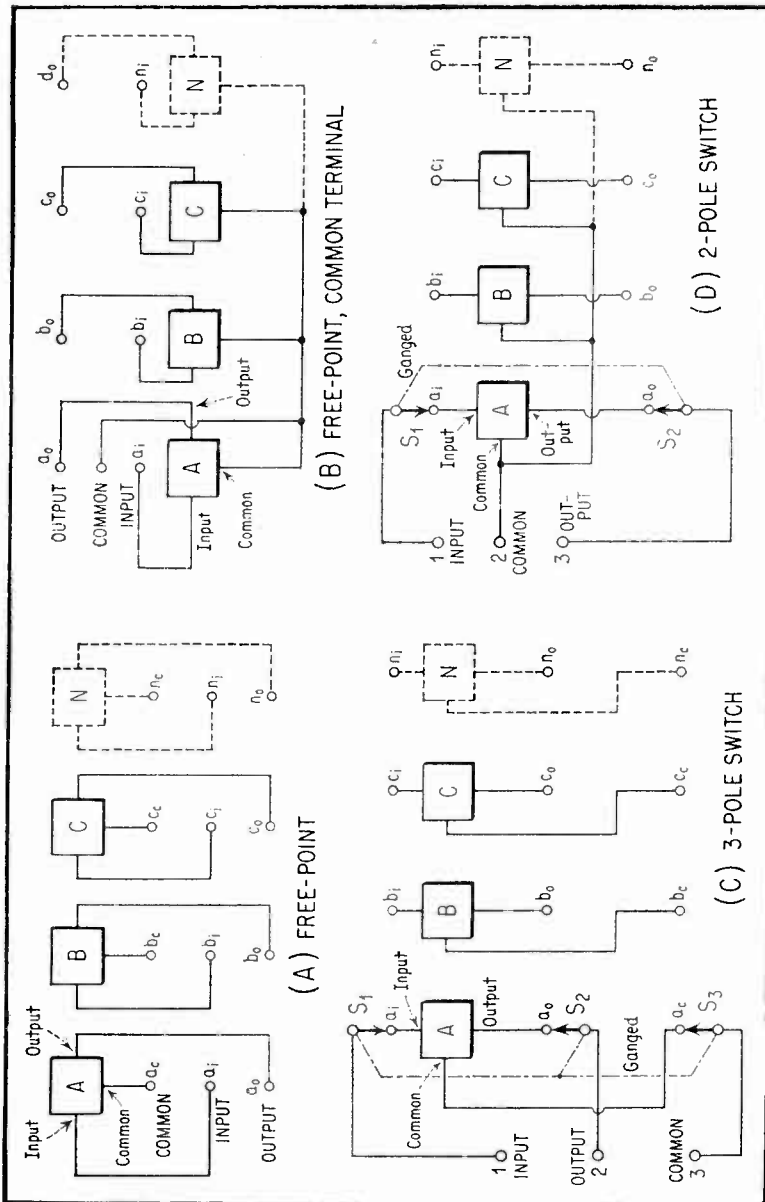

Fig. 2. 3-Terminal Configurations.

forded by this arrangement is equal to $n-1$, where n is the number of 2-terminal components. The number of terminals required is $n+1$. (Compare this with $2n$ for Figure 1A).

When one lead of each component may be connected to a single COMMON terminal on the panel, simplicity is obtained also in the switching circuit. Thus, in

figure 1(D) the selector switch has only a single pole, resulting in simplified wiring and often in smaller size and lower cost.

When it is desired to add the values of the components in the substitution box, the arrangements shown in Figures 1(E), 1(F), and 1(G) are available. Figures 1(E) and 1(F) show the schemes commonly em-

ployed in resistance decide boxes (resistors are added in series), while 1(G) shows the scheme for a capacitance decide box (capacitors are added in parallel). The free-point method of connecting the series components to panel terminals is shown in Figure 1(E) while a switch-type circuit for the series components is shown in Figure 1(F). A short-circuiting switch (S) is required for the parallel-type of totalizer (Figure 1(G)). The switch is shown in the position in which its shorting sector is connecting together all of the components. The total (A + B + C . . . + N) therefore is available at Terminals 1 and 2.

3-Terminal Configurations. Examples of 3-terminal units are transistors, resistor T-networks, capacitor T-networks, potentiometers, voltage dividers, and attenuators. Additionally, there are many simple component combinations having an input, output, and common terminal which may be incorporated into substitution boxes. These include filters, special-purpose RC and RL combinations, pi networks, resonant circuits, signal peakers, and notch circuits.

Figure 2 shows the principal methods of connecting 3-terminal units in a substitution box. When all three terminals must be accessible externally, 2(A) or 2(C) is

available. The free-point scheme (Figure 2A) requires $3n$ panel binding posts or jacks, where n is the number of components. These terminals are arranged in three rows: a_0 to n_0 for the input, a_1 to n_1 for the output, and a_n to n_n for the COMMON terminal of each component. When internal switching is permissible and all three terminals must be accessible externally, a 3-pole switch ($S_1S_2S_3$) is required, as shown in Figure 2(C).

When the common terminals of the 3-terminal units may be connected together, the simplified schemes shown in Figures 2(B) and 2(D) are available. In the free-point arrangement (Figure 2B), the number of 3-terminal units. This is a saving of $n-1$ over the number of terminals required by the full-free point arrangement (Figure 2A). The panel terminals are arranged in two rows (a_1 to n_1 for the input, and a_0 to n_0 for the output). A single COMMON terminal on the panel is connected to the common terminal of each component. In the switch arrangement (Figure 2D), a 2-pole switch (S_1S_2) takes the place of the 3-pole switch required in Figure 2(C).

4-Terminal Configurations. Examples of 4-terminal units are transformers, saturable reactors, H and O attenuators and bridge circuits. In most 4-terminal circuits,

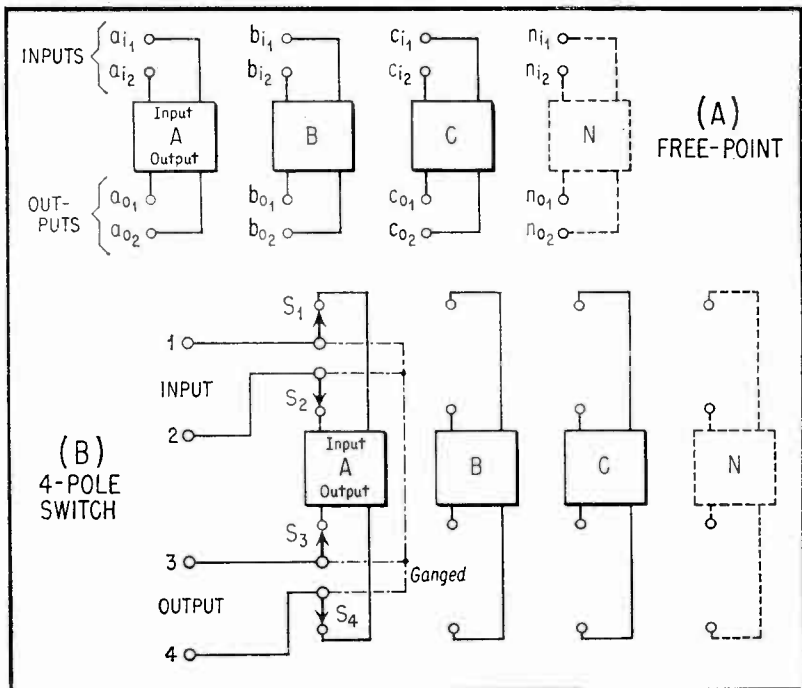

Fig. 3. 4-Terminal Configurations.

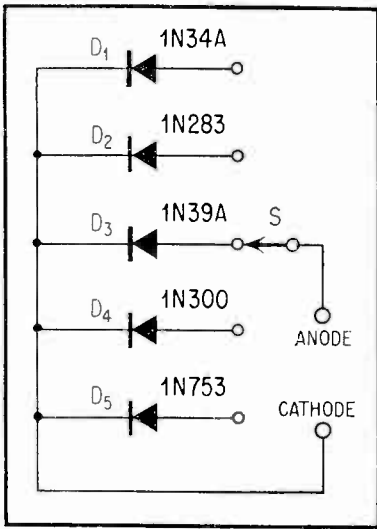

Fig. 4. Diode Box.

the input and output sections must be separated. This leaves no choice except to provide external access to both input and output terminals.

Figure 3 shows the principal methods of connecting 4-terminal units in a substitution box. When the input and output terminals must be accessible separately, the free-point circuit of Figure 3(A) is available. The 16 required terminals are arranged in two rows on the panel. (Terminals a_{11} , and A_{12} and a_{02} to n_{01} and n_{02} for the outputs). When internal switching is permissible, the circuit of Figure 3(B) is available. Here, the 4-terminal units (A, B, C . . . N) are selected with a 4-pole switch ($S_1S_2S_3S_4$). Only four panel terminals (1 and 2 for the input; 3 and 4 for the output) are needed.

Sometimes, one input terminal (or one output terminal) of each component can be grounded. This is not true often enough, however, to justify running a common line inside the substitution box and eliminating one row of terminals in Figure 3(A) or one switch pole in Figure 3(B). Similarly, it is possible in some applications to ground one input terminal and one output terminal of a 4-terminal device such as a transformer. But it is not advisable to make permanent common connections inside a substitution box containing 4-terminal components, since this will greatly limit the flexibility of the unit. The arrangements shown in Figure 3 therefore are the simplest for this type of box.

Practical Applications

This section describes the circuit details of several substitution boxes other than the familiar capacitor and resistor types. The usefulness of these boxes in circuit development and trouble-shooting will be apparent to the engineer and technician. These boxes and others may be used in combination for special applications.

The values given for components are those which have been found most useful by the Editors. Other values may be substituted for greater utility in boxes built for individual applications.

Diode Box. See Figure 4. This substitution box has been designed to supply a choice between five of the principal types of crystal diodes; general-purpose (D_1), high-conduc-tance (D_2), high-back-voltage (D_3), silicon (D_4), and zener (D_5).

Diode D_1 (1N34A) is a standard, general-purpose unit. The important characteristic of D_2 (1N283) is its forward current of 200 ma at 1 volt. The reverse operating

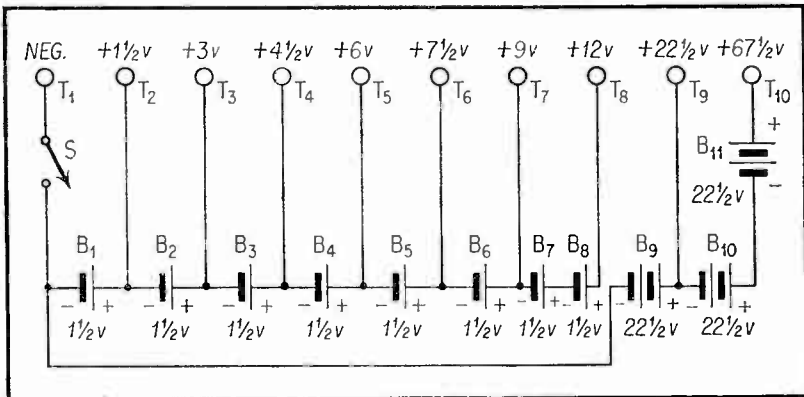

Fig. 5. Battery Box.

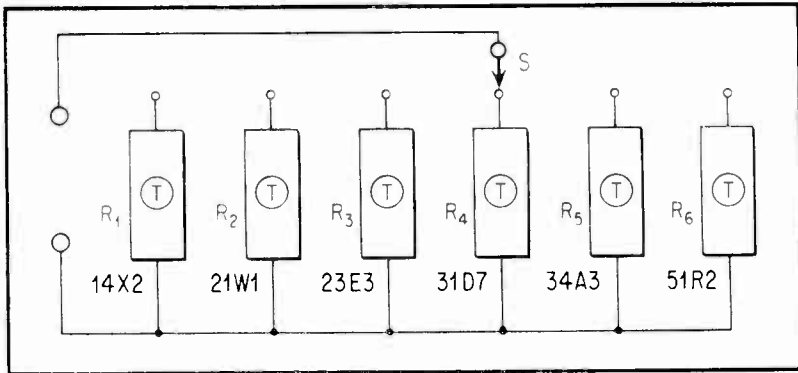

Fig. 6. Thermistor Box.

voltage of D_3 (1N39A) is 200 v. The silicon unit, D_4 (1N300) passes a reverse current of only 0.001 microampere at $-10v$. Diode D_5 (1N753) is a zener reference unit for 6.2-volt operation.

For specific applications, diodes of other types may be used in place of those specified in Figure 4. Also, a greater number of diodes may be employed.

Battery Box. This unit, shown in Figure 5, is a d-c power supply as well as a voltage substitution box. Because two or more voltages often are required separately at the same time, the free-point type of circuit (with Output Terminals T_1 to T_{10}) is employed instead of a switching scheme. Nine voltages between $1\frac{1}{2}$ v and $67\frac{1}{2}$ v are supplied. Various other voltage values may be obtained between the positive terminals. For example, 45 v may be obtained between T_9 and T_{10} .

The batteries are small in size and the unit accordingly may be built in a medium-sized chassis box. B_1 and B_8 are $1\frac{1}{2}$ -volt, Size-D flashlight cells. B_9 , B_{10} and B_{11}

are $22\frac{1}{2}$ -volt B-batteries (such as Burgess Type K-15).

Switch S opens or closes the circuit for any voltage taken between the NEGATIVE terminal and any other terminal.

The voltages specified in Figure 5 will satisfy most demands for bias and reference voltage substitution and for d-c supply for tube and transistor circuits.

Thermistor Box. See Figure 6. Six representative thermistors are arranged for selection by the single-pole rotary switch, S. These thermistors have the following nominal resistance values within $\pm 10\%$: R_1 38Ω , R_2 100Ω , R_3 310Ω , and R_6 $100,000\Omega$. All are Veco units; the manufacturer's type numbers appear in Figure 6.

The selected thermistors provide a wide range of uses in control circuits and stabilization networks. However, types having other resistances and temperature characteristics may be substituted for the one shown. Also, more than six may be employed if a wider selection is desired.

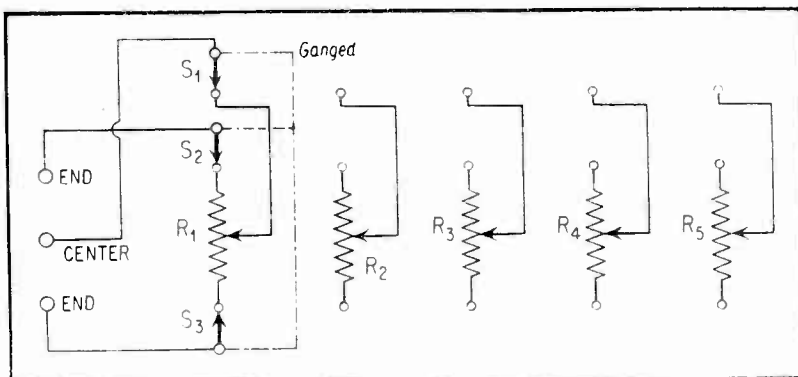

Fig. 7. Potentiometer Box.

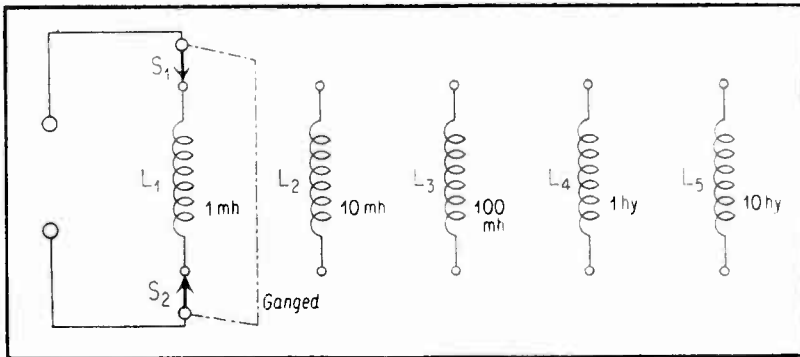

Fig. 8. Inductor Box.

Potentiometer Box. See Figure 7. This box has been found useful both in potentiometer and theostat substitution and in the bench assembly of special circuits such as bridges. Five potentiometers are shown, since this number usually is the maximum which may be mounted in a small box with direct-reading resistance dials. The potentiometers are selected by means of a 3-pole rotary switch, $S_1S_2S_3$.

The potentiometers in a low-range box should have the following resistance values: R_1 5K, R_2 10K, R_3 20K, and R_4 100K. Those in a high-range box should be: R_1 250K, R_2 500K, R_3 1 meg, R_4 5 meg, and R_5 10 meg.

Inductor Box. See Figure 8. A choice of five inductors (L_1 to L_5) is given, but more inductors might be added. For high Q and minimum interaction between coils, toroids are employed, except for L_1 which is a 1mh pi-wound r-f choke (National R-300). The U.T.C. toroids are: L_2 10mh, Type MQB-1; L_3 , 100 mh, Type MQE-7; L_4 , 1hy, Type MQA-12; and L_5 , 10 hy, Type MQA-17.

In order to disconnect both ends of unused coils from the circuit, a 2-pole rotary switch, S_1S_2 , is employed.

Variable Capacitor Box. See Figure 9. This box permits a tuning range between approximately 50 uufd and 920 uufd. The 2-pole, 4-position, rotary selector switch (S_1S_2) in Position 1 selects the 50-uufd unit, C_1 . In Position 2, the 100-uufd unit, C_2 , is selected. In Position 3, one 460-uufd section of the dual capacitor, C_3C_4 , is selected. In Position 4, the two sections of C_3C_4 are connected in parallel to give 920 uufd.

The capacitor dials may be made direct-reading in micro-microfarads. All wiring inside the box must be rigid and as short as possible.

Transistor Box. See Figure 10. Here, for the first time is a substitution box containing active elements. Five transistors are provided for a selection of useful characteristics from low-frequency audio performance to high radio-frequency operation.

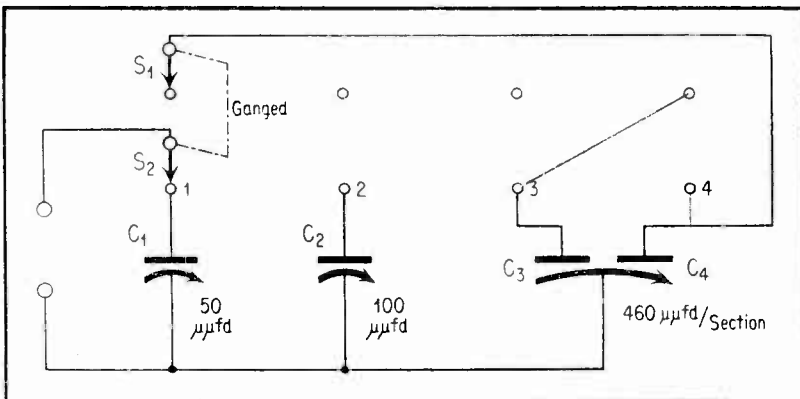

Fig. 9. Variable Capacitor Box.

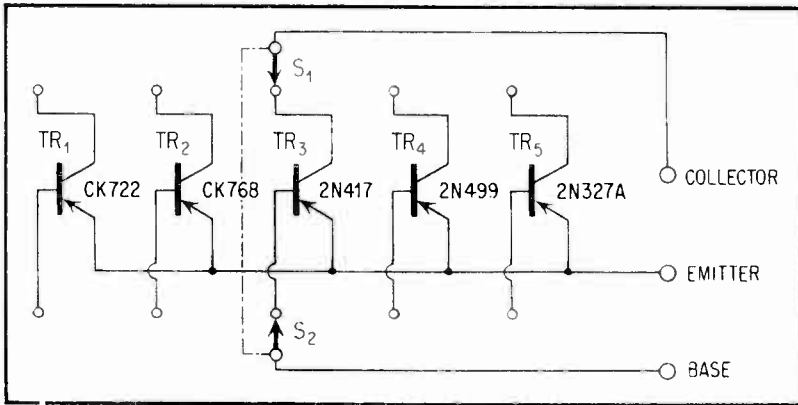

Fig. 10. Transistor Box.

While transistor types may be chosen according to particular demands of the user, the assortment shown in Figure 5 will cover most practical applications. TR₁ is a Raytheon CK722 general-purpose audio unit, TR₂ Raytheon CK768 af-if, TR₃ Raytheon 2N417 20-Mc cutoff, TR₄ Philco 2N499 250-Mc cutoff, and TR₅ Raytheon 2N327A silicon general-purpose. All wiring inside the transistor box must be kept rigid and as short as possible. The emitters are connected together and to the EMITTER terminal post. The collectors are selected by Section S₁, and the bases by Section S₂ of the 2-pole, 5-position, rotary switch, S₁-S₂. If a power transistor is included, the switch must have contacts heavy enough to carry the high direct current, and a heat sink must be provided for the power transistor.

Quartz Crystal Box. See Figure 11. This box is invaluable as the frequency-shifting element of an experimental crystal oscillator. It also will provide a selected crystal for selective filter development.

Ten crystals (X₁ to X₁₀) are indicated and may be chosen in frequency to suit the requirements of the user. At least four should be low-frequency crystals (e.g., 50, 100, 455, and 500 kc) for standardization and i-f filter work.

A short-circuiting type, single-pole, ceramic selector switch (S) is employed. This switch short-circuits and connects to the COMMON terminal all crystals except the one in use. A suitable switch of this type is Centralab Type 2000.

All wiring inside the crystal box must be short and rigid.

Transformer Box. See Figure 12. In this box, both the primaries and secondaries of the transformers are switched simultaneously by the 4-pole rotary selector switch, S₁S₂S₃S₄.

The transformer types may be chosen to satisfy the user's requirements which, of course, vary considerably among techni-

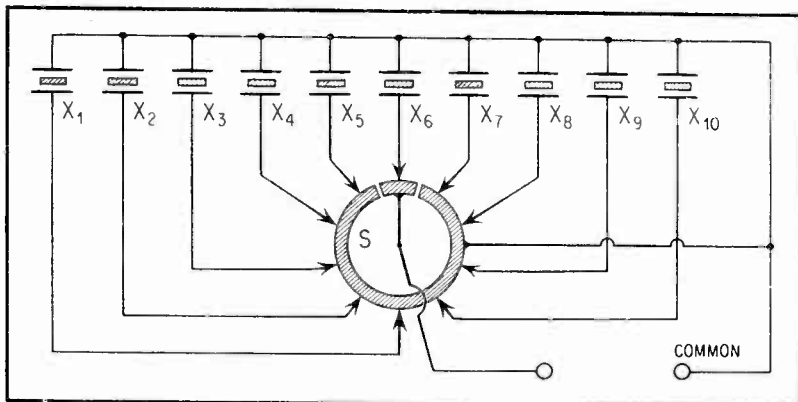

Fig. 11. Quartz Crystal Box.

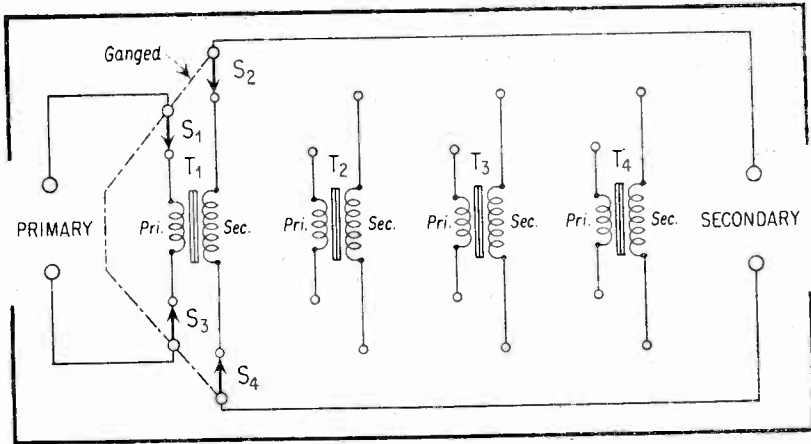

Fig. 12. Transformer Box.

cians. In order to minimize interaction between the units, only well-shielded transformers should be used in a substitution box. Unshielded units may be employed with somewhat less success, if they are mounted as far apart as possible and with their cores at right angles.

In order to minimize contact sparking, which eventually will ruin the selector switch, the power should be shut off in circuits before switching transformers in the substitution box.

RC-Network Box. Entire special-purpose networks may be switched in substitution boxes with the ease of switching single components. This is particularly true of resistance-capacitance networks, since they suffer very little from interaction and ac-

cordingly may be mounted close together in a box.

Figure 13 shows an example. Here, parallel-T null networks are switched. Each network may be set to a desired frequency notch by adjusting its R and C components. ($R_1, R_2, R_3, C_1, C_2, C_3$).

The common (ground-return) terminals of the networks are connected together and to the low OUTPUT terminal post. The input terminals are selected by Section C_1 , and the output terminals by Section S_2 of the 2-pole rotary switch, S_1-S_2 .

Additional Uses

Many other possible substitution boxes will suggest themselves to the alert tech-

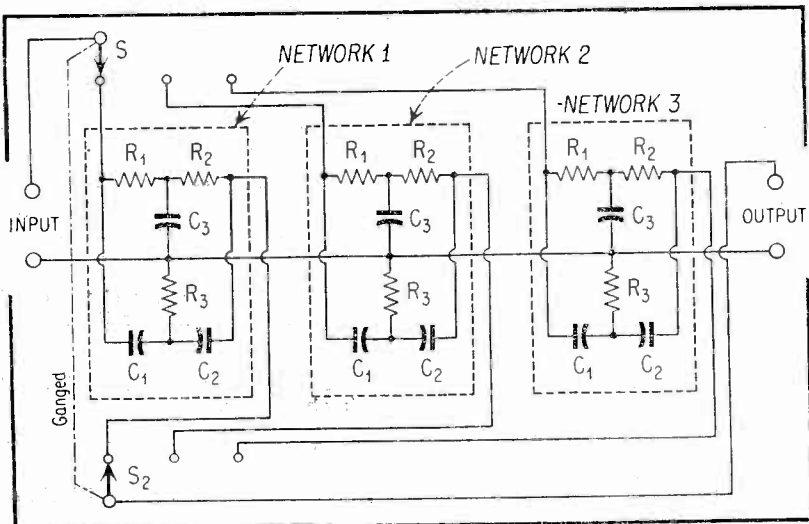

Fig. 13. Null Network Box.

nician. Some examples are L-pad, T-pad, simple T-networks, bridged-T networks, semiconductor rectifiers, and Thyrite varistors.

Combinations of substitution boxes can save the busy experimenter a great deal

— n r i —

Transistor Receivers

(From page four)

sistors change in value and open. Paper bypass capacitors develop leakage, may short or become open. Electrolytics can short, become leaky, open, or have a high power factor. Loudspeaker cones dry out and their voice coils may get off center. Tuning capacitors may short, volume controls may become noisy. Etched circuit boards may develop cracks in the foil and poorly soldered connections may start acting up. Batteries can develop high internal rf-af resistance and thus provide undesired coupling between stages.

Because very low operating voltages are used in transistorized receivers, breakdowns in capacitors are rather rare. Changes in resistance values are more

of time ordinarily spent in soldering and unsoldering trial components. When considering a new substitution box, however, study the basic configurations given in Figures 1, 2, and 3 are discussed in the early part of this article, in order to determine the best arrangement for the box.

— n r i —

often due to failure to take proper precautions in soldering rather than due to heat caused by excess current flow.

Tubes, as you know, develop leakage and shorts between electrodes, become gassy, or lose cathode emission. Transistors, on the other hand, never suffer from gas but may break down internally, or an open can develop between a lead and the base, emitter or collector. Overheating due to incorrect bias, or, in some cases, aging can change the characteristics to the point where the transistor will not work satisfactorily.

So far we have covered the main differences you will encounter in servicing transistor sets. Now let's look at the symptoms you will be called upon to correct and their common causes. Note particularly that hum is not a problem.

In servicing a transistor set certain defects commonly occur. These may or may not always result in the same troubles. However, check each item and possible defect in the list below. This will often save much time. Should the trouble persist then make use of the list of symptoms and their causes.

Always check:

The battery to see if it is weak, dead, or is connected with the wrong polarity. Do not perform any service work with a weak battery in use. Always try another known to be good, or an eliminator.

Inspect for rosin joints and poorly soldered connections. If you are suspicious, heat the joint and completely melt the solder, particularly in printed circuits.

Defective loop antenna; check continuity and look to see if the Ferrite core is broken.

Defective i-f transformer, check continuity with ohmmeter.

Defective oscillator coil; check continuity.

Open earphone jack; check with ohmmeter.

There are also other defects which com-

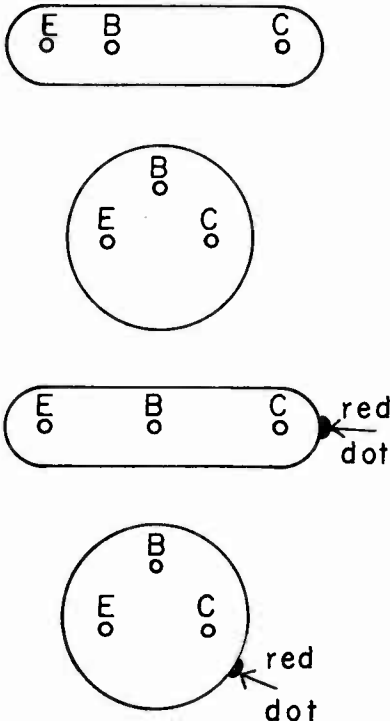

Figure 3

monly occur but they may be time consuming to check and are generally tied in with symptoms. They need not be checked unless there is some reason to definitely suspect their presence.

In servicing a transistor set do not remove and replace transistors when the set is on. All leads of the transistor may not make or break contact at the same time and the resulting current surges may ruin the transistor.

Before using an ohmmeter, disconnect the batteries and remove the transistors or cut through the foil to isolate parts. If this is not done ohmmeter measurements will have no meaning.

When servicing transistor sets at the bench, do the work on a large bath towel or an old piece of rug. This will prevent small screws and other pieces of hardware from bouncing off the bench on to the floor where they cannot be found. Keep several small boxes, not easily upset, to hold small parts and one large enough to hold these boxes, the receiver and its cabinet.

Refer to the manufacturer's Instruction Manual whenever possible as you will find many useful hints on the particular set you are servicing. Instructions on removing receivers from their cabinets are particularly useful until you gain experience. In many cases the dial knobs *screw* off instead of pulling off. Some have center inserts which are unscrewed and removed, permitting the dial to be pulled off. Do not use force in trying to pull off knobs as you normally would in a larger type set.

Symptoms and Probable Cause

DEAD RECEIVER

Weak battery.
Dead stage.
Rosin joint in a signal circuit.
Earphone Plug open.
Resistor changed in value.
Capacitor leaky or shorted.
Capacitor open.
Voice coil of loudspeaker open.
Open oscillator coil.
Open i-f transformer.
Open loop or broken core.
Loop leads shorting to chassis or circuits.
Incorrect voltages on transistors.
Defective transistors.
Use a localization procedure.

DEAD AND NOISY

Weak battery.
Defective local oscillator.
Volume control defective.

Localize to a stage by shorting collector loads.

WEAK RECEIVER

Weak battery.
Rosin joints in signal or supply circuits.
Loop open.
Capacitors leaky.
Capacitors open.
Defective diode crystal.
Incorrect forward bias on a transistor.
Defective transistor.
Alignment required.
Use a localization procedure.

RECEIVER HAS LOW AUDIO GAIN

This symptom falls under the heading of a weak receiver in that the volume is low. In this case, however, both distant and local stations will be received at low volume, indicating that the rf-if section has enough sensitivity to pick up distant stations. With the condition of low audio gain, the signal may also be distorted. Look for:

Weak battery.
Rosin joints and poorly soldered connections in the audio section, particularly at the volume control.
Defective audio transformers.
Open coupling capacitors.
Resistors open due to poor connections.
Leaky bypass and filter capacitors.
Incorrect operating voltages on transistors.
Defective transistors.

(Page 22 please)



"There's nothing wrong with it. I want you to make something go wrong with it!"

Christmas Suggestions

This issue of NRI News and the October-November issue (pages 16-17) feature a complete catalog of items available through your Supply Division. As a final reminder, be sure to place Christmas orders early and avoid the disappointment of delayed shipments. Should you have any specific questions about a particular instrument, time-payment arrangements, etc., please feel free to write us for further information. Order by letter or coupon—page 19.



Weller Model
8100K
Soldering Kit
\$5.95

Contains 100-watt Weller "Junior" Soldering Gun, soldering aid, brush, roll of rosin-core solder. The ideal gift. A \$7.95 value for only \$5.95 postpaid.

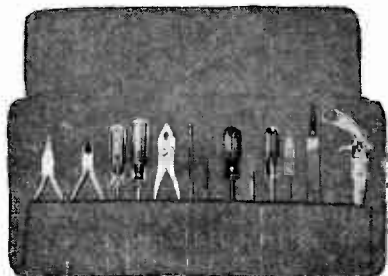

Professional Tool Kit—\$10.95

A real money-saving value. Thirteen carefully selected, top quality tools—not inexpensive store counter specials. If purchased separately, the same tools would run \$14.00 or more at dealer's net prices. Recommended for NRI experiments; all Radio-TV service work. Yours thru the NRI Supply Division for only \$10.95.—we pay the postage.

Cabinet for
your NRI
VTVM
\$4.00



Sturdy aluminum; gray baked-on wrinkle finish; brushed finish chrome handle. Protect your VTVM and improve appearance. Quick installation; exact fit. All necessary screws included. \$4.00 postpaid.

Ungar Soldering Pencils

Ideal for printed circuit work. Requires practically no maintenance. Time saving; heats to soldering temperature in a few seconds. Comfortable—handle is always temperate. Interchangeable heating units with easily replaceable tips.

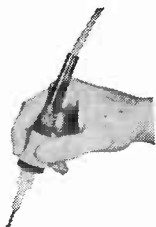

Junior Kit includes handle with cord, one 37½ watt heating unit and one package of ten tips. List price \$5.00 NRI student price \$3.98 postpaid.

Senior Kit has handle with cord, three heating units (47½, 37½, and 23½ watt) and package of 10 tips. List price \$9.25, NRI student price \$7.40 postpaid.

Shopmate ¾" Electric Drill

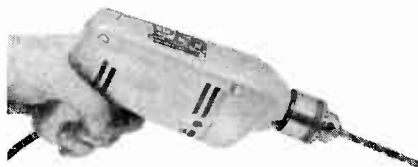

Save over \$8.00 on this exceptional ¾" drill. (Retail for \$26.95). Has the power, low speed, and ideal size for Radio-TV work. Takes bits from 1/16" to a full ¾". Shipped complete with rubber covered handle that attaches to either side of drill for safe, two-hand operation. Genuine geared chuck with key. Weight 3 lbs. Length 9"; height 6". Price includes postage. \$18.50.

Drake Soldering Iron



Made by the well-known Drake Electric Works. Rated at 60 watts, 110-120 volts. ¼" pyramid tip. Perfect for experiments—service work. Complete with stand. \$3.75.

**Cabinet for
your NRI
Radio
\$4.95**

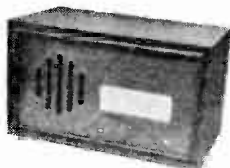

Designed especially for the NRI Radio receiver. Modern appearance; greatly improved tone. Front is well-seasoned Philippine Mahogany plywood; White Gum sides, top, and bottom. Sanded smooth. Shipped knocked-down. Easy—fun to assemble and add your own finish to match room decor. Just \$4.95, postpaid.

Replacement Parts Kits



A wide assortment of the most needed replacement parts for Radio-TV service work. Standard Parts Kit would run over \$50.00 at dealer's net prices. Includes condensers, resistors, rectifiers, transformers, oscillator coils, pilot lamps, volume controls, electrolytics, dial repair kit, speaker cement and solvent, line cords, plus seven of the most commonly needed replacement tubes. Fresh, first quality, name-brand parts—not surplus. Priced to save and earn you money. Choice of two kits.

Standard Kit price \$29.95 including heavy gage steel tool box. Weight—12 lbs. Shipped express collect.

Economy Kit price \$19.95 including heavy gage steel tool box. (Does not include speaker cement and solvent, volume control assortment, rectifiers, or tubes.) Weight 11 lbs. Shipped express collect.

Model W VTVM TV Probe



Extend range of your Model W VTVM to 30,000 volts for DC measurements in TV circuits. Fits right over standard test lead probe. Nothing to remove, no screws to tighten. SAFE—easy to use. Complete instructions included. \$5.50 complete including postage.

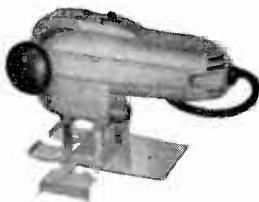

**Shopmate
Jig Saw
Model 2100**

Cuts practically *anything!* 2" x 4" wood or 1/2" steel in seconds. Does work of rip saw, jig saw, cross cut, scroll, coping, hack, band, and keyhole saw. Safe to use, easy to handle. Powerful 1/4 horsepower makes its own starting hole on inside cuts. Outstanding features include built-in light, angle adjustment cuts up to 45° bevels, rip fence and 8-circle guide, auxiliary handle—attaches to either side. Shipped complete with blades. Nationally advertised price is \$29.95. NRI price—\$21.00 including postage.

**Use Handy Order
Blank—Page 19**

**Argos
Tube
Caddies**



The easy orderly way to store tubes or carry tubes and tools on service calls. Just the thing for spare-time servicing. Choice of two caddies. Popular Carry-All Caddy built of sturdy 5/8" plywood covered with tough, luggage-type pyroxilin fabric. Size 21" x 15" x 8". Capacity 262 tubes. Price \$13.95.

Junior Tube Caddy. Size 15 1/2" x 12 1/2" x 8". Holds 143 tubes. \$9.95.

**Weller
Models
D-440 and
D-550
Soldering
Guns**



Model D-440, dual heat, rated at 100-150 watts. List price \$14.90. NRI price \$10.73 postpaid. Model D-550, dual heat, rated at 200-250 watts. Heavy duty. List price \$16.25. NRI price \$11.71, postpaid.

NRI Professional Model 250

5-Inch Wide-Band Oscilloscope

Specifications

Vertical sensitivity: .023 VRMS after internal calibration is adjusted.
 Frequency response: Flat from 13 CPS to 2.5 mc. Down .05DB at 11 CPS. Down 1.5 DB at 3.58 mc. Down 3.5 DB at 4.5 mc.
 Horizontal sensitivity: 1.0 VRS.
 Frequency response: Flat from 20 CPS to 90 kc. Down .8 DB at 12CPS. Down 3 DB at 250 kc.
 Uses 11 tubes including dual types giving equivalent of 19.
 Rise time: .05 ms.
 Sweep frequency: 10 CPS to 500 kc.
 Push-pull on-off switch.
 Operates from 110-120 volts, 60 cycle only.

IMPRESSIVE CABINET AND PANEL

Sturdy aluminum cabinet finished in handsome black wrinkle. Dimensions 9 $\frac{3}{4}$ " x 13 $\frac{3}{4}$ " x 15 $\frac{1}{2}$ ". Brushed aluminum panel with deep etched black lettering. Red and black control knobs. "5-way" binding posts. Strong carrying handle and rubber feet on bottom of cabinet to prevent inarring. Added features that give you professional appearance and operation. Overall shipping weight, 23 lbs.

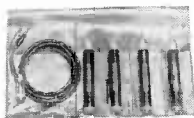

PROFESSIONAL PROBE SET AVAILABLE AT EXTRA COST

Even though most scope observations and tests can be made with ordinary test leads, special probes are necessary to get maximum use from this instrument.

This DeLuxe Probe Set, designed exclusively for use with the Model 250, includes complete instructions, sturdy roll-up carrying case, shielded cable and these probes. 1. High impedance, low capacity probe. 2. Crystal demodulator probe. 3. Resistive isolating probe and 4. Shielded direct probe. Price complete—only \$14.95.



Speedex fully automatic Wirestripper. Delayed return action. A real time-saver. Well built. \$4.95 postpaid.

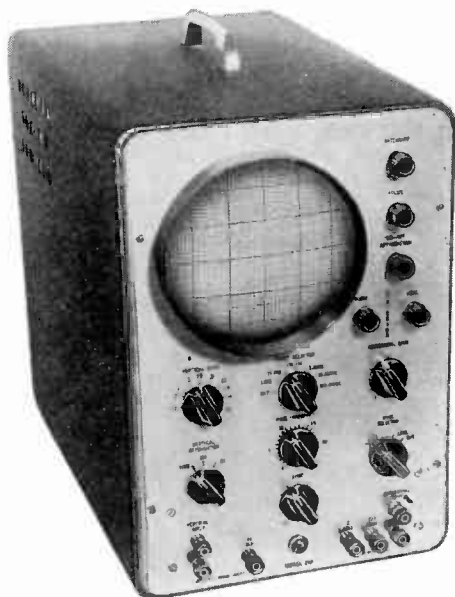

Kit—\$89.50
Assembled—\$139.50

NRI DESIGNED for your complete satisfaction. For color, black-white TV servicing; AM-FM and transistor radios; high fidelity; industrial Electronics.

HIGH SENSITIVITY—.023 (RMS) volts per inch; but not noisy.

READ PEAK-TO-PEAK VOLTAGES directly. No calculations required.

RUGGED CONSTRUCTION; built to last. Truly professional appearance.

WIDE BAND RESPONSE. No wave distortion transients. Actually shows 3.58 color burst.

USES PHASE INVERTER TUBES in horizontal and vertical push-pull output stages.

SYNCS AND LOCKS EASILY—with positive action—on any TV receiver signal. Traces TV signals; locates defective sync circuits.

ACCURATELY MEASURES RIPPLE OUTPUT of any power supply. Check auto radio vibrators dynamically.

VERTICAL AMP RESPONSE—flat 13 cps to 2.5 mc down 1.5 db at 3.58 mc.

SWEEP RANGE—10 cycles to 500 kc. Uses special NRI linearity circuit.

PLENTY OF BRIGHTNESS. No need to turn off or dim lights to see trace. 2400 volts on CRT.

PERFECT FOR SQUARE WAVE ANALYSIS and FM-TV alignment with a sweep generator.

QUALITY COMPONENTS THROUGHOUT. Standard 90-day EIA parts and labor warranty.

AVAILABLE ON LOW MONTHLY TERMS. Uses two printed circuits, clear instructions, easy to build.

B&K Model 1075 Television Analyst

UNIQUE NEW SIGNAL INJECTION TECH-
NIQUE. Saves Trouble-Shooting Time and Work



\$254.75

(Note: The Model 1075 is not a "beginner's" instrument. It is a practical instrument for the experienced TV technician and well-advanced student only.)

FEATURES

R.F. Supplies complete r.f. and i.f. signals with video and audio modulation to quickly troubleshoot each stage in each of the sections of the TV receiver. Enables you to check the r.f. sensitivity and AGC settings of TV receivers.

VIDEO Reproduces a complete test pattern on the screen of the TV picture tube and injects signals into each video stage of the receiver for fast, visual trouble-shooting and correction—anywhere, anytime. Easy to check bandwidth, resolution, shading and contrast capabilities of the TV set.

SYNC Provides composite signal, positive and negative.

AUDIO Provides a 4.5 mc sound channel, FM modulated with approximately 25 kc deviation. Injection of the 400 cycle tone signal simplifies trouble-shooting of the audio section.

COLOR Enables you to trouble-shoot and signal trace color circuits in color TV sets. Generates white dot and crosshatch patterns on TV screen for convergence adjustments.

Generates full color rainbow pattern of orange, red, magenta, blue, cyan, green to test color sync circuits, check range of hue control, etc.

SET ADJUSTMENT to Check and adjust the vertical and horizontal linearity, size and aspect ratio of television receivers.

Other Applications: Picture source to demonstrate the performance of TV receivers. Advertising display of pictures and sound message on TV screens. Transmitter for video and audio paging systems. Checking the performance antenna systems.

Shipped express collect. Weight 38 lbs.

Model O Filament Tester

Completely self-contained. Quick checks receiver and TV picture tubes for filament continuity. Uses two long-life pen light cells. A real time saver on servicing jobs. Has built-in pin straighteners and also checks fuses, pilot lamps. Easily carried in jacket; size: 1" x 3½" x 5¾". Handsomely styled, custom made case, brushed aluminum panel with black lettering. Complete instructions printed on back. The ideal "extra" Christmas gift priced at only \$5.50, postpaid, complete with batteries.



ORDER BLANK

National Radio Institute Supply Div.
3939 Wisconsin Ave.
Washington 16, D. C.

Send me the following item(s):

I enclose \$..... (check or money order).

- Weller 8100K Soldering Kit\$ 5.95
- NRI VTVM Cabinet\$ 4.00
- Junior Ungar Soldering Kit\$ 3.98
- Senior Ungar Soldering Kit\$ 7.40
- Professional Tool Kit\$ 10.95
- Shopmate ¾" Electric Drill\$ 18.50
- Drake Soldering Iron\$ 3.75
- NRI Radio Cabinet\$ 4.95
- Economy Parts Kit\$ 19.95
- Standard Parts Kit\$ 29.95
- Model W VTVM TV Probe\$ 5.50
- Shopmate Jig Saw\$ 21.00
- Argos Carry-All Tube Caddy\$ 13.95
- Argos Junior Tube Caddy\$ 9.95
- Weller Model D-440 Gun\$ 10.73
- Weller Model D-550 Gun\$ 11.71
- Model 250 Oscilloscope Kit\$ 89.50
- Assembled Model 250
Oscilloscope\$139.50
- Oscilloscope Probe Set\$ 14.95
- B&K Model 1075 TV Analyst\$254.75
- Speedex Wirestripper\$ 4.95
- Series String Filament Tester\$ 5.50
- Tell me how I can buy the equipment I
have checked on monthly terms. (Items priced
over \$16.00 only)

Name

Student No.

Address

City Zone State

Express Office

If you live in Washington, D. C. add 2% D. C.
Sales Tax.

Yours—for the first time - - -

a choice of three NRI Professional multi-purpose meters

ON SERVICE CALLS, customers much prefer having their receivers serviced in the home where possible and practical. There are probably a number of reasons for this—two are: the thought of missing favorite programs for an extended period—and—automatically associating “taking the set to the shop” with a steep repair bill.

If the trouble is not due to defective tubes, the usual procedure is to make voltage and resistance measurements to localize the source of failure. Then, service the receiver or at least give the customer an estimate.

Here, successful service technicians find a portable “multi-range” meter is a real convenience—cuts down on time per job—means increased profits. In addition to complete portability and compact size, a multi-range meter has another important advantage over a VTVM—you can measure voltage between any two points in a receiver—not from various points to the chassis or B—.

THE NRI Supply Division now gives you a choice of three Professional quality instruments to fit any budget and need. Each provides you with an ideal combination of features, ranges, and functions most wanted for Electronic circuit checking for bench-work or service calls.

NEW Model 48

VOM WITH MIRRORED-SCALE
20,000 ohms per volt DC
with DC polarity reversing switch
5,00 ohms per volt AC
wide-band frequency response

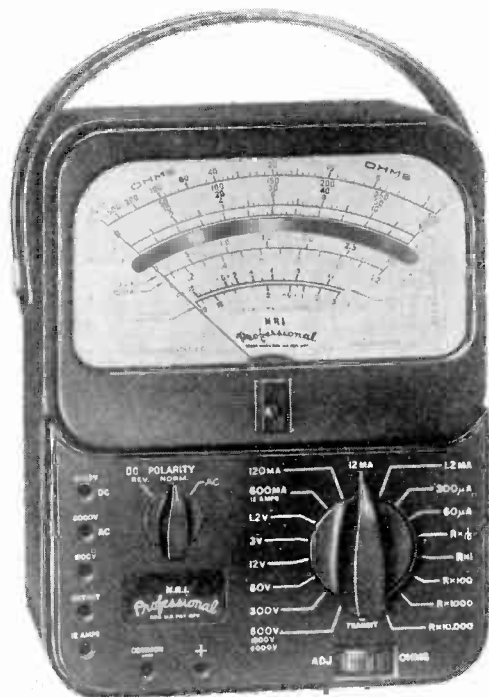

FEATURES

- * **More Ranges:** The Model 48 has 59 . . . which starts lower and go higher than other instruments of its size and type.
- * **An Extra Low Resistance Range:** 2 ohms at center scale.
- * **An Extra Low Voltage Range:** 1.2 v. full scale. AC and DC.
- * **An Extended Low Current Range:** a 60 microamp first DC range.
- * **An Extra Large 5¼" Meter** with polished mirrored-scale.
- * **DC Polarity Reversing Switch.**
- * **Wide Frequency Response AC and DB Ranges.** Flat from 15 cps to 100 Kc plus or minus 1 DB.
- * **“Transit” Switch Position.** Protects meter during transportation.
- * **Solid Brass Banana-Type Jacks and Plugs.**
- * **Custom-Molded Phenolic Case and Panel.**

SPECIFICATIONS

- * **8 DC Voltage Ranges:** 20,000 ohms-per-volt (Neg. and Pos. Reading) 0-1.2-3-12-60-300-600-1200 6000 volts.
- * **8 AC and Output Voltage Ranges:** 5000 ohms-per-volt. Built-in 600 V. blocking capacitor. 0-1.2-3-12-60-300-600-1200-6000 volts.
- * **7 DC Current Ranges:** (Neg. and Pos. reading) 0-60-300 ma. 0-1.2-12-120-600 ma. 0-12 amps.
- * **5 Resistance Ranges:** self-contained batteries. 0-200-2000-200,000 ohms. 0-2-20 meg-ohms.
- * **8 Wide Frequency Response Decibel Ranges:** from -20 to plus 77 DB. 0 DB = 1 mw., 600 ohms.
- * **Rugged 50 Microamperes meter plus-minus 2% accuracy.**
- * **1% Multipliers and Shunts.**
Size: 5½" x 7" 3½"

MODEL 48 complete with batteries, test leads, and manual.

\$42.95
plus postage

NEW Model 47

Pocket-Size, High-Sensitivity V-O-M
20,000 OHMS PER VOLT DC
5,000 OHMS PER VOLT AC

The Model 110 is a rugged, pocket-sized test set, with full-sized instrument performance, ranges and readability.

6 DC Voltage Ranges: 20,000 OHMS PER VOLT. **6 AC Voltage Ranges:** 5000 OHMS PER VOLT 0-1.5-6-30-150 600 3000 volts AC and DC.
5 DC Current Ranges: 0-60-600 microamp 0-6-60-600 MA. **3 Resistance Ranges:** 0 2000-200,-000 ohms. 0-20 megohms. **6 Decibel Ranges:** -2 to plus 71 DB; 0 DB = 1 Mw, 600 ohms.
Wide-Vision, 3 1/2 Inch. Rugged Meter. 50 microamperes sensitivity, plus or minus 2% accuracy. **1% Multipliers and Shunts.** **Low Resistance Banana-Type Jacks and Plugs.** **Size:** 1-11/16" x 3 1/2" x 5 3/8". **MODEL 47** complete with test leads, batteries and manual.

\$32.95
 plus postage

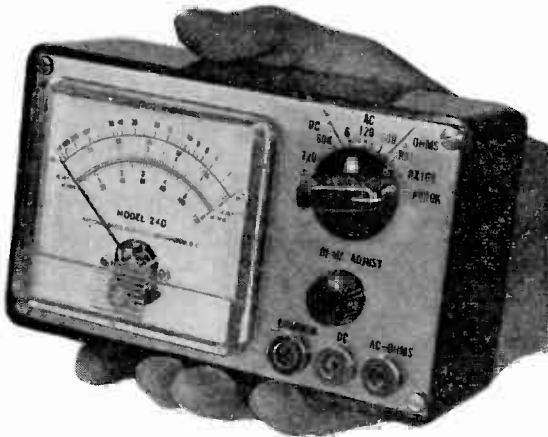
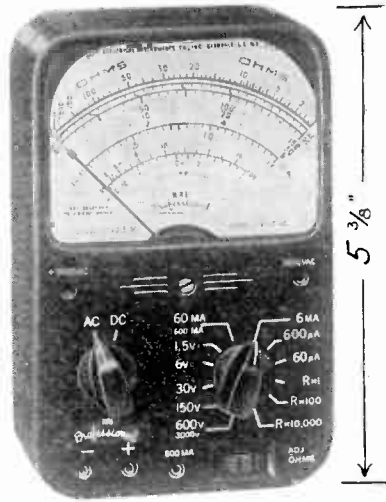

Model 240 V-O Kit

Takes less than an hour to assemble —pocket the savings. Quality components throughout. Rugged 3 1/2" 50 microamper plus minus 2% meter. Sensitivity: 20,000 ohms-per-volt DC.

DC Ranges: 0-6-120-600.

AC Ranges: 0-6-120-600.

Ohmmeter Ranges: 0-1000 (can estimate 1/2 ohm) 0-100,000 ohms, 0-10 megohms.

Shipped complete with batteries and assembly - operating instructions. Size: 3 3/4" x 6 3/4" x 2".

\$16.95
 plus postage

USE THIS CHART TO FIGURE PARCEL POST CHARGES

	Local Wash., D. C.	Zones 1 & 2, up to 150 ml.	Zone 3, 150 to 300 ml.	Zone 4, 300 to 600 ml.	Zone 5, 600 to 1000 ml.	Zone 6, 1000 to 1400 ml.	Zone 7, 1400 to 1800 ml.	Zone 8, Over 1800 ml.
Model 48 VOM	.24	.39	.44	.52	.63	.76	.91	1.05
Model 47 VOM or Model 240 VO	.21	.31	.34	.38	.45	.52	.61	.69

Optional High-Voltage TV Probe for Model 47, Model 48, Model 240.

\$5.50

Extends D range to 30,000 volts. S A F E. Easy to use. Instructions included.

ORDER COUPON

National Radio Institute Supply Division
 3939 Wisconsin Ave.
 Washington 16, D. C.

I enclose \$_____ cost of equipment I have checked below plus \$_____ postage. Ship the equipment to me at once. (See above chart for postage to your zone)

- Model 47 VOM with manual, test leads, batteries \$32.95
 - Model 48 VOM with manual, test leads, batteries \$42.95
 - Model 240 V-O Kit with manual, test leads, batteries \$16.95
 - High Voltage TV Probe for instrument I have checked \$5.50
- Tell me how I can buy this equipment on monthly terms.

Name Student No.

Address City State

If you live in Washington, D. C., add 2% D. C. Sales Tax.

Transistor Receivers

(From page 15)

Defective loudspeaker.
Use a localization procedure.

RECEIVER HAS LOW RF-IF GAIN

This is characterized by normal reception of strong local stations but weak or no reception when tuning for weaker stations. Check the following:

Realignment required.
Defective transistor in mixer-oscillator or in i-f stage.
Defective diode detector crystal.
Defective overload (AVC) diode crystal.
Incorrect operating voltages on mixer or i-f transistors. Particularly check the base-emitter voltages. Lower than normal forward emitter bias voltage reduces sensitivity.
Leaky bypass capacitors.
Defective loop.
Rosin joints or poorly soldered connections.
Incorrect type replacement transistor.
Diode detector reversed by other servicemen.
Installing in cabinet disturbs adjustment of capacitor trimmers—seal position of screw heads with nail polish.
Localize to a section or stage with Scope, Signal Generator or Signal Tracer.

RECEIVER MUFFLED OR DISTORTED

Natural overloading — volume control turned too high.
Weak battery.
Defective transistor.
Incorrect operating voltage on a transistor; check particularly the emitter-collector and emitter base. In the latter case, low voltage in the first audio transistor will cause distortion.
Resistor changed in value.
Defective detector and overload diode crystals.
Defective audio transformers.
Loudspeaker cone torn.
Metal particles in loudspeaker voice coil gap.
Reflex circuit—distortion natural at low volume levels.

RECEIVER SQUEALS AND HOWLS

Nearby TV set operating.
Rosin joint or poorly soldered connection in "common ground" circuit. (This is circuit that connects to low rf potential end of collector supply battery.) Jumper required between mounting lugs of tuning ca-

pacitor gang and if transformer shields.
Weak battery.
Riveted connections on printed circuit board defective—solder rivets to printed wiring at point of contact.
Low capacity filter capacitors.
High resistance connection at electrolytic capacitor terminals.
Excessive strength of oscillator signal try new transistor and/or shunt-oscillator tuned circuit with a 1-megohm resistor.
Transistor in rf-if section has excessive gain. Try another transistor of same type and realign.
Wrong type transistor used in rf-if stages.

INTERMITTENT RECEPTION

Defective battery—connect meter across battery to see if voltage changes when set becomes intermittent. If it does, try a new battery and repeat check.
Rosin joints and poorly soldered connections.
Cracks in printed wiring of circuit board.

Equipment for Transistor Servicing. The equipment required for this type of work is found in most TV-Radio shops. Other items worth having are:

A pencil soldering iron.
A small pair of tweezers.
A gooseneck lamp to throw light on the work and to "see" through printed boards.
A tuned signal tracer.
A variable voltage auto radio battery eliminator.
A multigrange milliammeter or a VTVM with a 100-ohm resistor.
A supply of diagrams such as Howard Sams.
A scope such as the NRI Model 250.
A magnifying glass to locate hairline cracks in printed circuits.

A few 8-mfd, 14-mfd and 100-mfd, 15-volt tantalum capacitors.
A supply of 1/16" diameter 60/40 solder (60% tin—40% lead).
Piece of carpet or large towel for bench top.

For hi-fi work an audio signal generator, a square wave generator and a scope such as the NRI Model 250 are required.

Stage Localization Techniques. The methods used in servicing tube receivers will work just as well in transistor sets with one exception. The circuit disturbance test cannot be used on a transistor set because no disturbance results when you touch the input of the various stages.

You can, however, signal trace with a

Be not afraid of going slow Be afraid of standing still.

tuned signal tracer or with a scope. You can employ stage blocking techniques, shorting the various output loads to kill noisy signals. You can use an af-if signal generator for signal injection tests.

In all cases you must be able to identify the input and the output of each stage. Three possible circuit configurations are used as shown in Fig. 2. The common emitter which corresponds to the grounded cathode amplifier is almost universally used in all stages. With this amplifier the input element is the base which corresponds to the control grid in a vacuum tube. The point from which signals are taken is the collector which has the same electrical position in the circuit as the plate of a tube.

On occasion you will find a common base amplifier. Then the emitter is the input element and the collector the output. Very seldom will you find a transistor used in a common collector circuit. When you do, the base is the input and the emitter the output. In all cases the emitter will connect to one side of the battery through a resistor. This side of the battery whether it be + or - corresponds to B- in a tube receiver and the ground lead of the signal generator, signal tracer or CRO should be connected to this point when servicing. Usually, but not always, this point in the schematic is identified by a ground symbol and any point shown as being grounded, such as the tuning capacitor frame can be used for test connection purposes.

Voltage Measurements. In transistor receivers voltage measurements are always made with the volume control turned all the way up and the dial set to a point where no signals are received. The first measurement is on the battery. If it is low by as much as 10%, either use a new battery or battery eliminator while servicing. If the eliminator voltage cannot be reduced to the right value before the set is connected, load the output of the eliminator with resistors until the correct voltage can be obtained. One or two (in parallel) 10-ohm, 25-watt resistors should do the job. If you decide to use a battery, measure the total current drain with the new battery before you start servicing. If the current is greater than the maximum shown in the service literature, it is quite likely the battery will run down before you can repair the receiver. This is why most servicemen prefer to have an eliminator handy. You can measure the current with a milliammeter (use highest range first) or you can connect a 100-ohm resistor in series with either lead and measure the voltage drop across it. The current in ma is equal to the voltage reading plus one decimal place. For example, 1.5 volts = 15-ma and .23 volts = 2.3-ma, etc.

With normal supply voltage you can proceed to take measurements at the transistor terminals, comparing them to those given in the service measurements. The important measurements are the emitter to collector and emitter to base voltages. In a normal circuit the emitter to collector voltage will be somewhat less than the full supply voltage. This voltage is a measure of the reverse bias on the collector. With PNP transistors, the collector will be negative with respect to the emitter. With NPN transistors the collector will be positive with respect to the emitter. The emitter to base voltage is a measure of the forward emitter bias. It will be quite small, on the order of a few hundredths of a volt. With PNP, the emitter will be positive while with an NPN, the emitter will be negative with respect to the base. The schematic will enable you to identify NPN and PNP transistors. In the PNP the arrow on the emitter symbol points toward the base. On the NPN symbol, the arrow points away from the base symbol.

If the collector voltage is too low, check the forward bias on the emitter. Excessive bias will result in excessive emitter-collector current and a larger than normal voltage drop across the collector load. If the collector and emitter are at essentially the same potential, the transistor is shorted.

Excess voltage indicates insufficient bias on the emitter-base or a broken lead inside the transistor.

Always measure the total load current and compare it to the manufacturer's recommended value. Excessive current probably indicates a defective transistor. By removing the transistors one at a time and noting the effect on the total current drain, you can tell if any transistor is drawing current and if the current is excessive. When removing or replacing a transistor, the set should be turned off. It is easy to remove transistors that plug into sockets. When the transistors are soldered in place, open the connections to the collector and emitter. In a printed circuit, use a sharp knife to cut through the foil near the connections. Flow solder over the cuts to restore normal operation. Again observe the

Help Fight TB



Use Christmas Seals

precautions of turning the set off when cutting the leads and when restoring them.

Ohmmeter Measurements. As with a tube receiver, the battery must be disconnected when checking the circuits and parts with an ohmmeter. You must be on the lookout for conductive paths through the transistors and second detector diode. Where possible, unplug the transistors or cut the foil leads to all emitters and collectors as well as one lead to the second detector crystal. Then you can make point to point resistance measurements using the schematic as your guide. If you wish to check individual parts that are shunted by parts that may conduct, cut through the foil to one lead of the part to be tested. This will prevent a false reading through some parallel connected part. In each case flow solder over the cut when you have completed your tests.

Checking the Local Oscillator. In a tube receiver a check of the dc voltage across the oscillator grid resistor will show if the oscillator is working. In a transistor no dc voltage is automatically developed in the oscillator circuit.

To see if the oscillator is working, you can measure the ac tank voltage directly across the oscillator section of the tuning capacitor. For this purpose, you can use:

The NRI Model W VTVM.
The NRI Model 250 Oscilloscope.
The NRI Model 35 Signal Tracer.

You can indirectly check the oscillator by picking up its radiated signal on a nearby receiver. You can feed the unmodulated rf signal on the NRI Model 90 signal generator, tuned to the oscillator frequency of the set, into the oscillator circuit. If stations are then received, the oscillator is dead.

If you find a dead oscillator stage, check the coil continuity with your ohmmeter, and go over all connections with a hot soldering iron to boil out rosin joints. Check the dc operating voltages on the transistor and finally try a new oscillator coil and a new transistor.

In making signal injection tests your signal generator must have a low impedance output and you must be able to reduce the output to a very low value to prevent overloading. In addition the output of the signal generator must feed through a series blocking capacitor to avoid changing dc operating voltages when signals are fed into the various stages. The NRI Model 90 signal generator fills all requirements.

To get an idea of the amount of signal

being fed into the receiver, keep the output at the voice coil below 5 milliwatts for small receivers and below 50 milliwatts for larger sets. The following voice coil voltages will enable you to gauge the output power in the voice coil.

5 milliwatts
3.2 ω voice coil = .13 ω VAC
16 ω voice coil = .28 ω VAC
50 milliwatts
3.2 ω voice coil = .4 ω VAC
16 ω voice coil = .89 ω VAC

The voice coil impedance is roughly equal to 1.5 times the dc resistance. Unsolder one voice coil lead to check its resistance.

When aligning, keep the signal generator at or below the above values. This will prevent overloading.

Replacing Transistors. Whenever possible use the same type (number) transistors for replacement purposes. When one transistor of a push-pull out circuit is defective, replace both using a matched pair. This is the way push-pull output transistors are sold and most wholesalers will not break a package to sell a single transistor of this type. When the transistors plug into sockets, cut the leads of the replacements to the same length as the originals so the new transistors will fit snugly in their sockets.

If the transistors are to be soldered in place make the connections one at a time being certain the base, emitter and collector are soldered to the proper points. Always hold the lead between the soldered connection and the transistor with long nose pliers. The heat will then be absorbed by the pliers and will not reach the transistor. This is also the method to use when installing germanium diodes.

If you substitute a different type number, the replacement must be designed for the same purpose as the original. Use an NPN for an NPN and a PNP for a PNP. The results in i-f and first af stages will be quite satisfactory.

Difficulty may or may not be encountered in mixer and rf circuits.

When you install a duplicate transistor check the operating voltages, changing the value of the bias resistors if the voltages are considerably off and the gain is too high or too low. Generally the original parts values will be satisfactory.

As you gain experience, you will learn many short cuts and will find that in many

ways transistor receivers are easier to service than tube sets. Get all the experience you can because transistorized TV receivers

are definitely on their way and without experience today's TV expert will be in for a rough time.

HI FI CORNER

by John G. Dodgson

THIS MONTH: ODDS AND ENDS

Poll. The recent request for suggested NRI News articles (see page 31, August-September issue) showed a substantial interest in hi-fi among students & graduates.

There just wasn't space to break down this large field. However, if there are any particular items you would like to have covered in this column, drop me a line. Please address it to my attention—you can be sure I'll do my best to cover the most popular suggestions.

Three Channel Stereo

The most recent trend in Stereo is a third or center channel. There is good reason for it.

Stereo sounds best when the speakers are at least 8 to 12 feet apart. Unfortunately, due to recording techniques, this can cause a "hole in the middle" on some records. (Improper speaker phasing does this, too.) To eliminate the "hole in the middle," a third channel can be utilized in that position. This is not a new technique but was used in some deluxe stereo tape installations a few years ago. Paul Klipsch (of Klipschorn fame) delivered a paper on the subject at the 1957 Audio Engineering Society Convention.

Now, it might, at first, seem rather silly to go to the expense and trouble of setting up separated or two channel sound and then filling up the middle. However, as Klipsch found and stated, "a surprise occurred;" the center channel was perfectly real and not just a simulated effect to fill up a hole in space. Sounds remembered as arising in the center of the stage occurred there; one ceased to hear sounds from the 3 speakers but actually sensed a spread across the curtain of sound."

This third channel is fed a signal from both "outside" channels; thus any two channel source, stereo tape or stereo disc, can provide this center channel. Since it is not a true separate channel the term "phantom" is sometimes applied. Incidentally, this center channel system discussed here should not be confused with

the CBS (Heath), Stephens Stereodot, Weathers Harmony, and other similar systems where only one of the speakers carries bass and the others carry treble. In this center channel system all three speakers carry both bass and treble.

The signal fed to the center channel can be an additive mixture of sound from the left (A) and right (B) channels, called A + B; or it can be the "difference" between channels or A - B.

When identical amplifiers and speakers are used in both the left and right channels the A - B method is the simplest and least expensive method to use. A typical set up is shown in Fig. 1. Note that the center speaker is connected between the 4 ohm tapes of both power amplifiers.

Some problems can occur with this set-up. First the signal fed to the center will only be the "difference signal" when both channels are perfectly balanced—from the cartridge to the speaker. This seldom happens so there will always be some output from the center—even on monophonic records. This is OK providing there isn't too much output. Best results are achieved when the center channel is down 3 DB to 6 DB as compared to the outer channels.

Should the center speaker be more efficient than A and B, excessive output will completely destroy the stereo effect. Connecting an L or T pad to the speaker is

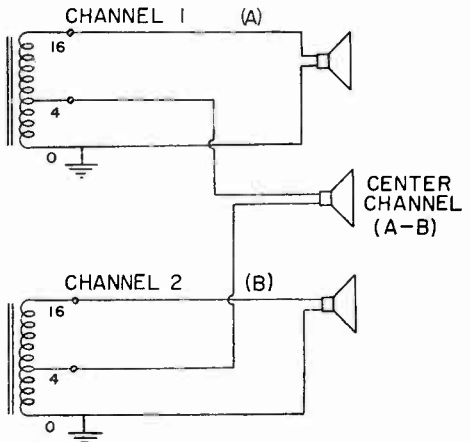

Fig. 1. Center channel obtained by the A - B method.

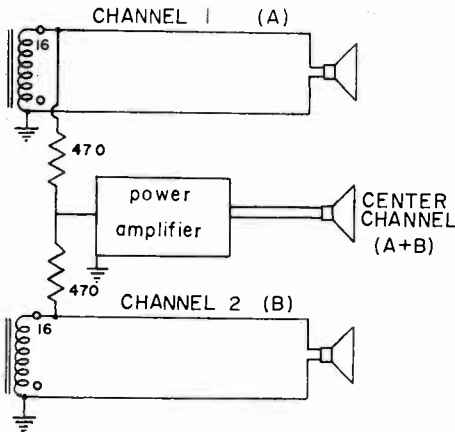

Fig. 2. Center channel obtained by the A + B method.

not a solution since this will reduce damping and increase transient distortion.

Connecting the outer channels together through the center speaker causes some crosstalk although the attenuation is still about 25-30 DB. Connecting the A and B transformers together can sometimes cause instability. This can usually be eliminated by strapping together the "common" or O impedance taps of the A and B output transformers with No. 14 or heavier wire.

All in all, A - B is tricky, but when it works out it is quite an improvement. If you have the room (at least 12 feet) to spread out the A and B speakers, try the A - B center channel—all you need is another speaker. If you are using 4 ohm speakers for A and B channels you can't use this A - B system since crosstalk would be excessive. A and B speakers of 8 ohm impedance would be OK. If A and B speakers are 16 ohms the 8 ohm taps can be used for the center A - B speaker.

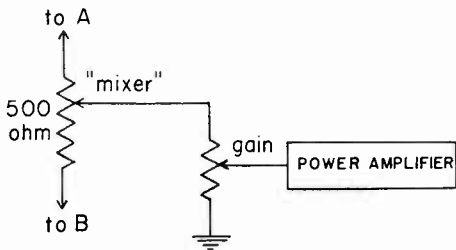

Fig. 3. A special mixer circuit for the A + B center channel.

The more sophisticated and expensive center system is the A + B. As shown in Fig. 2, another amplifier is needed besides the speaker. Any power amplifier will do so long as it has a sensitivity of about 1 volt for full output. Since the center channel should be -3 to -6 DB with respect to the A and B channels very little power is needed. Even with inefficient acoustic suspension type speakers, a 10 or 12 watt amplifier would be satisfactory.

The advantage of this system is that the level of the center channel is controlled and it permits output with a monophonic source. The resistors shown in Fig. 2 can be replaced with a potentiometer as shown in Fig. 3. This "mixer" control will permit varying the content of the center channel. By simply moving the slider toward A or B the center sound can be predominately A or B. Thus the center speaker need not be placed exactly between the A and B speakers to achieve perfect balance.

Crosstalk attenuation using the circuit of Figures 2 and 3 exceeds 35 DB and there is little chance of instability problems.

I was called on recently to supervise a stereo conversion of a very high quality monophonic system. The only possible place in the room to place the second channel speaker was about 17 feet away from the first—resulting in the listeners sitting in the middle. The "ping-pong" effect on stereo was terrible. To eliminate this "hole in the middle" (it could be better described as a cavern), we first tried the A - B system of Fig. 1 using two high quality 8" speaker systems for the center. This was satisfactory for stereo but monophonic reproduction was, of course, unaffected and was actually too annoying to be used at all. To eliminate this we next tried the A + B circuit of Fig. 2 using the mixer circuit of Fig. 3 which I devised for this installation. The result is the best stereo and mono reproduction I've heard yet.

In conclusion: the best possible stereo at the present time is very wide separation of the left and right channels with a center channel filling up the resulting "hole in the middle."

This is much superior to a closer positioning of the speakers to eliminate "the hole in the middle."

Notes: Fig. 1: center channel speaker impedance is not critical.

Fig. 3: connections from the "mixer" control should be to any taps on the output transformers. The "mixer" control can be any value from 500 ohms to 100K ohms.

NRI ALUMNI NEWS



Howard Smith	President
F. Earl Oliver	Vice President
Jules Cohen	Vice President
William Fox	Vice President
Joseph Stocker	Vice President
Theodore E. Rose	Executive Sect.

Thomas Hull of New York is President-Elect of NRI Alumni Association for 1960

**Two Incumbent Vice-Presidents Returned
To Office; Two New Ones Elected**



Thomas Hull

The votes are in, the tallying has been completed and Thomas Hull of New York has emerged as the President-Elect of the NRIAA for 1960!

Hull won handily, but his opponent, Jules Cohen, Secretary of the Philadelphia Camden Chapter, also made a good showing. It would be well to keep Cohen in mind as a future presidential prospect.

Two incumbent Vice-Presidents were returned to office: F. Earl Oliver of the Detroit Chapter and Howard Smith of the

Springfield (Mass.) Chapter. Both Oliver and Smith are former presidents who have repeatedly been re-elected as vice-presidents. John Babcock, of the Minneapolis-St. Paul Chapter, the retiring president who will finish his term on December 31, was elected to a vice-presidency for 1960. Returns from New York constituted a change from the past several years. William Fox of the New York Chapter seemed to have a strangle hold as a vice-president representing this area. But this year the vote was split fairly evenly between him and Frank Catalano, also of the New York City Chapter. As a result Roland Tomlinson of the San Francisco Chapter came in as the winner. With this line-up, three major sections of the country are represented by vice-presidents: the Northeast, the Mid-West, and the Pacific Coast.

When Thomas Hull takes office as President on January 1, it will not be for the first time. He was president in 1955, was also elected to a vice-presidency for the two previous years.

Hull was born in 1902 in Liverpool, England, emigrated to the U. S. in 1906. After leaving high school at the end of his third year to help support his family, he later graduated from a night school course at the New York Electrical School. He was employed by the New York Telephone Company in 1923 and is still with them. Since 1942 he has worked the graveyard shift from midnight to 8:00 A.M., covering the east side of Manhattan as emergency repairman.

He was married in 1933, has two daughters and three grandchildren. Graduating from NRI in 1949, he has since conducted a Radio-TV service business from his home. He has held various offices in the New York City Chapter, including the Chairmanship, and is one of the chapter's ablest and most experienced speakers on Radio-TV servicing.

The NRI Alumni Association is fortunate to have a man of Thomas Hull's background and experience to serve as President for the coming year.

HAGERSTOWN (CUMBERLAND VALLEY) CHAPTER members were intensely interested in a lecture delivered by J. B. Straughn of the NRI Instruction Staff, who accompanied Executive Secretary Ted Rose on the latter's annual visit to the chapter. Mr. Straughn gave a talk on the use of the oscilloscope in Radio-TV servicing and employed the new NRI Model 250 Oscilloscope to demonstrate his lecture. Members' comments after the meeting were that the new scope was tops—one of the best-designed instruments introduced by NRI.

The next meeting was devoted to a general discussion of current electronic topics. The chapter's annual banquet has been postponed until a later date.

SOUTHEASTERN MASSACHUSETTS CHAPTER as a surprise to Ted Rose, Executive Secretary of the NRI AA, on the occasion of his annual visit to the Chapter, held the meeting at White's Restaurant, Westport, Mass., instead of at its regular meeting place. A delicious buffet lunch of chicken, turkey and lobster rolls with all the trimmings was part of the evening's program. This was followed by a question-and-answer and discussion period. The members attending agreed that it was a very pleasant evening.

At the previous meeting, two members brought in their problem sets to be analyzed. All the members proceeded to ask the necessary trouble-shooting questions about the sets and the questions were recorded on the black-board along with the probable causes. Checks were made and explained until the trouble was found. Temporary substitutions were installed and the set was operated to satisfy every member that it was okay, whereupon the more experienced members entered into a detailed discussion. The members who brought in the sets were then to repair them at home.

Two new members who have recently joined the Chapter are Wayne Legge, South Easton, Mass., and Manuel Velloza, Fall River, Mass. Welcome to the Chapter, gentlemen.

PHILADELPHIA-CAMDEN CHAPTER is pleased with the large number of members attending its meetings this fall. At one meeting there were as many as seventy members present. This meeting featured Jack Alschuler of the B & K Manufacturing Company and George Conneen, Phila-

delphia Sales Representative, who gave an excellent demonstration of the B & K Television Analyser. The members were greatly impressed with this fine demonstration. Mr. Alschuler and Mr. Conneen also distributed fifty books among the attending members. This was not enough to go around, of course, but they later mailed the books to those members who did not get one at the meeting.

As we go to press plans have been made for representatives of Motorola to deliver talks and demonstrations at an up-coming meeting and at subsequent meetings representatives from Zenith to deliver talks on transistor Radios and still another representative from Philco for demonstrations on Philco Portable TV receivers. And of course the Chapter's own Harvey Morris generously devotes what time he can to delivering talks and demonstrations on TV trouble-shooting. These talks by Harvey Morris are very popular with the members.

The following have recently been admitted to membership in the Chapter: Joseph Schaller, Elmer Lamond, and James Middleton, all of Philadelphia; Romeo Buono, Fort Washington, Pa., and Bernard McGuigan, Mantua, N. J. A cordial welcome to these new members!

MINNEAPOLIS-ST. PAUL (TWIN CITY) CHAPTER'S former chairman, John Berka, a full-time Radio-TV serviceman of wide experience, spoke on the value of some of the Radio-TV trade magazines and how they can help in service work. PF Reporter and similar magazines were discussed.

At another meeting John Berka gave the members a good review lecture on the problems and procedures used in servicing TV tuners. To illustrate his lecture he brought along two tuners for the members to inspect, pointed out the components that usually fail and how to replace them.

The chapter held its annual member-and-wife banquet at the Venetian Inn in St. Paul. The banquet was a big success in every way. The steaks were delicious (Executive Secretary Ted Rose can testify to the excellence of these Western steaks). Following the banquet, the group adjourned to Paul Donatelli's home where they were treated to a showing of slides of John Berka's trip through Yellowstone National Park. Everyone thoroughly enjoyed the evening.

The conclusion of each meeting of the

Getting an idea should be like sitting down on a pin; it should make you jump up and do things.

E. L. Simpson in Good Business

chapter is followed by an informal social period at which members get together for a discussion of their problems over coffee and doughnuts. The members voted to purchase an automatic coffee urn to facilitate the brewing of the quantities of coffee needed for this purpose.

PITTSBURGH CHAPTER has welcomed new members Dennis Tomaszewski and Frank Murray to its ranks. Pleased to number you among the members of the Chapter, gentlemen.

Howard Tate delivered a talk on the use of the oscilloscope in Radio-TV Servicing. Chairman Thomas Schnader gave a demonstration of trouble-shooting procedure on a defective TV receiver, and Frank Skolnik spoke on the subject of licensing Radio-TV technicians. All of these were fine talks.

Another excellent talk was made by guest speaker Edward Gaiden, factory representative for Motorola. Mr. Gaiden's talk was devoted to printed circuits. The members found this lecture so interesting and practical that at the following meeting Chairman Thomas Schnader suggested the possibility of another visit by Mr. Gaiden as a guest speaker.

LOS ANGELES CHAPTER is now settled in its new headquarters in the rear of Secretary Earle Allen's home. The address is 11523½ S. Broadway. The members are very happy over having found such suitable headquarters, which will be used not only for meetings but also as a workshop.

In setting up the new headquarters Earl Dycus made a donation toward the chapter's expenses; Earle Allen likewise donated toward these expenses and also tools; Mike Raftis contributed an extension cord; Eugene De Caussin gave a workbench and two soldering irons; Kenneth Williams donated his NRI transmitter; William Edwards contributed a table; and C. M. Sparks, a new member, made the chapter the gift of an oscilloscope. The chapter also has a VTVM and a signal generator for use at the meetings. The chapter is indeed off to a good start in its new headquarters.

Lee Chavez started a training program for the members, in connection with which Julio Solis brought in two radio receivers for the members to put their NRI training to work on. Earl Dycus and Earle Allen also brought in two TV receivers in both of which the trouble was located and repaired.

In addition to C. M. Sparks, Morris Cotton and Joseph Cisternino are the most recent

additions to the membership of the chapter and they are very welcome.

NEW YORK CITY CHAPTER continues to give its members enjoyable and educational evenings on its meeting nights.

At recent meetings the members heard from Charles Frankiewicz on his TV experiences and problems he encountered, and how he solved them.

Ralph Pincus still talks on ham operations, explaining all about equipment used and how some of the circuits operate.

Tom Hull gave an excellent lecture on AGC circuits, explaining about the clamper action and how it works. At another meeting he explained how high-pass and low-pass filters work. His latest lecture covered many points of information on how to locate the trouble in dead radio receivers.

SAN FRANCISCO CHAPTER'S Chairman J. Arthur Radsdale gave a fine talk in which he explained the operation of a simple transistor timer. To illustrate his talk he used three blackboard schematic diagrams of the transistor timer. The diagrams were those given in the article "Simple Transistor Timer" in the October issue of Radio-Electronics magazine. This was a very interesting lecture.

The newest member to join the Chapter is Mr. R. K. Martin. A cordial welcome to you, Mr. Martin.

The chapter has been currently featuring a dog session at its meetings, to which members can bring their tough Radio-TV servicing problems to be discussed and solved. This of course is one of the most important advantages of membership in a local chapter of the NRI Alumni Association.

DETROIT CHAPTER has adopted the suggestion that its members drop a postcard to the secretary informing the chapter on the type of program that interests them most so that plans can be made for upcoming meetings. This should help the chapter in arranging programs on subjects that the members want.

The chapter generally holds its annual Fall Stag Party at the Chry-Moto Club in Windsor. But because the club was not available, the party was held this year at the chapter's regular meeting place. A tasty shrimp-and-fish supper was served, also cold cuts, cheese, olives, pickles, etc. The feature of the evening was three excellent sound color movies



Members of Flint Chapter getting acquainted with visitors from Detroit Chapter. In foreground, Chairman Bill Neumann talking to Ted Rose.

shown by Leo Blevins. The first one was about Florida, the second was a vaudeville sketch, and the third a travel film on Hawaii. These were all interesting and entertaining but the one on Hawaii was an exceptionally fine and interesting film. There was no time left for the customary penny-ante poker game but the members were glad to forego the poker game in order to see these excellent films.

The next day a group of members drove up to Flint to attend the meeting of the Flint Chapter as guests. See the report on the Flint Chapter.

FLINT (SAGINAW VALLEY) CHAPTER extended a gracious welcome to Executive Secretary Ted Rose upon his visit to the chapter. J. B. Straughn of the NRI Instruction Staff was scheduled to deliver a lecture on the use of the oscilloscope in Radio-TV servicing and to demonstrate the new NRI model 250 Oscilloscope at this meeting. The members were understandably disappointed that Mr. Straughn was unable to make the trip due to illness. Ted Rose promised, however, not only that he himself expected to make regular annual visits to the chapter here-



Talking things over at a Flint Chapter meeting. Facing camera, former chairman Warren Williamson discussing a problem with Aaron Triplett, in whose attractive and well-equipped Radio-TV Sales & Service Shop the meetings are held,

after but also that he would make every effort to bring Mr. Straughn with him on his next visit.

The following members of the Detroit Chapter were also present at this meeting as guests: John Nagy, Earl Oliver, John Stanische, Ellsworth Umbreit, Prince Bray, Asa Belton, and Jim Kelley.

After the business meeting John Nagy, Earl Oliver and Ted Rose addressed the assembled members, then Aaron Triplett displayed and gave a short talk on the B&K Television Analyst. The rest of the meeting was devoted to socializing among the members of the chapter and their guests, during which cold drinks were served. Both the chapter members and the guests spent a very pleasant evening.

MILWAUKEE CHAPTER was pleased to admit Constantine Duvaleris as its newest member. Right away he demonstrated his desire to cooperate in the activities of the chapter by volunteering to assemble the NRI Model 240 Volt-Ohmmeter Kit donated to the chapter by National Headquarters, the assembled instrument to be kept for chapter use.

The chapter has resumed its talks and discussions on the problems involved in TV servicing.

NEW ORLEANS CHAPTER was treated to a preview and discussion of the 1960 models of Westinghouse Radio and TV receivers by Mr. Milton Kennedy, representative of the Westinghouse Service Department.

CHICAGO CHAPTER has re-elected its current slate of officers to serve for 1960. They are: Charles Teresi, Chairman; Frank Dominski, Secretary; and Morris Lerner, Treasurer.

Chairman Teresi outlined a plan to have members become acquainted with some of the test equipment they have but with which they are not too familiar, to enable them to put it to full use. It was decided to start with the oscilloscope. The always cooperative and able Walter Nicely volunteered to demonstrate the scope and he continued with this demonstration into the next meeting. He showed the members the features of his own scope which he built some time ago. Minas Anabian had a set in which the FM portion was giving him trouble and Walter Nicely analyzed the set and explained to him where to look for the trouble.

To NRI students and graduates in the Evanston and Oak Park areas: because you are such close neighbors, the Chicago Chapter extends a particularly cordial invitation to you to come to its meetings and get acquainted with the members so that all may benefit by this association. See the Directory of Local Chapters for information on time and meeting place.

SPRINGFIELD (MASS.) CHAPTER members were enthusiastic about a trip they made through a tube rebuilding plant. As guests of Mr. Gerald Rogers, owner of New England Electronics Components, Inc., they were conducted through the plant by Mr. Rogers and Mr. Pinks, Chief Engineer. The members were shown the process of cleaning and re-necking of old tubes in preparation for rebuilding, the cleaning of old and new glass, the settling of fluorescent material, then on through the various processes of inserting electron guns, evacuating, basing, heat treating, activating, etc., and all that goes into the making of picture tubes.



Springfield Chapter members on their tour through New England Electronics Components, Inc., tube rebuilding plant. Arnold Wilder inspects neck of finished tube.

This very interesting tour was made possible by Robert Lyman, an honorary member of the chapter, who unfortunately was unable to be present but was represented by Mr. Fred Tuohey, a member of the Soundco Staff.

The chapter recently admitted John T. Parks, Ware, Mass., to membership. Our congratulations, John.

— n r i —

Flying High—Voltage

Although he didn't know it, Benjamin Franklin came very close to death when he flew his kite in a thunderstorm. A Russian scientist is said to have been electrocuted while trying to duplicate Franklin's feat.

Directory of Local Chapters

Local chapters of the NRI Alumni Association cordially welcome visits from all NRI students and graduates as guests or prospective members. For more information contact the Chairman of the chapter you would like to visit or consider joining.

BALTIMORE CHAPTER meets 8:00 P.M., second Tuesday of each month, 100 N. Paca St., Baltimore. Chairman: Joseph Dolivka, 717 N. Montford Ave., Baltimore, Md.

CHICAGO CHAPTER meets 8:00 P.M., second and fourth Wednesday of each month, 666 Lakeshore Dr., West Entrance, 33rd Floor, Chicago. Chairman: Charles Teresi, 3001 N. Norica, Chicago, Ill.

DETROIT CHAPTER meets 8:00 P.M., second and fourth Friday of each month, St. Andrews Hall, 431 E. Congress St., Detroit. Chairman: John Nagy, 1406 Euclid, Lincoln Park, Mich.

FLINT (SAGINAW VALLEY) CHAPTER meets 7:30 P.M., second Saturday of each month, 3149 Richfield, Flint. Chairman: William Neuman, 1613 S. Kiesel, Bay City, Mich.

HAGERSTOWN (CUMBERLAND VALLEY) CHAPTER meets 7:30 P.M., second Thursday of each month, North Hagerstown Senior High School, Hagerstown, Md. Chairman: Reginald Ankeney, 138 Main St., Clear Spring, Md.

LOS ANGELES CHAPTER meets 8:00 P.M., second Friday of each month, 11523½ S. Broadway, Los Angeles. Chairman: Thomas McMullen, 1002 W. 187th Pl., Gardena, Calif.

MILWAUKEE CHAPTER meets 8:00 P.M., third Monday of each month, Radio-TV Store & Shop of S. J. Petrich, 5901 W. Vliet St., Milwaukee. Chairman: Philip Rinke, RFD 3, Box 356, Pewaukee, Wis.

MINNEAPOLIS-ST. PAUL (TWIN CITY) CHAPTER meets 8:00 P.M., second Thursday of each month, Walt Berbee's Radio-TV Shop, 915 St. Clair St., St. Paul. Chairman: Walter Berbee, 328 E. Co. Rd., A-2, St. Paul, Minn.

NEW ORLEANS CHAPTER meets 8:00 P.M., second Tuesday of each month, home of Louis Grossman, 2229 Napoleon Ave., New Orleans. Chairman: Herman Blackford, 5301 Tchoupitoulas St., New Orleans, La.

NEW YORK CITY CHAPTER meets 8:30 P.M., first and third Thursday of each month, St. Marks Community Center 12 St. Marks Pl., New York City. Chairman: Edward McAdams, 3430 Irwin Ave., New York 63, N. Y.

PHILADELPHIA-CAMDEN CHAPTER meets 8:00 P.M., second and fourth Monday of each month, Knights of Columbus Hall, Tulip & Tyson Sts., Philadelphia. Chairman: John Pirrung, 2923 Longshore Ave., Philadelphia, Pa.

PITTSBURGH CHAPTER meets 8:00 P.M., first Thursday of each month, 134 Market Pl., Pittsburgh. Chairman: Thomas D. Schnader, R. D. 3, Irwin, Pa.

SAN FRANCISCO CHAPTER meets 8:00 P.M., first Wednesday of each month, 147 Albion St., San Francisco. Chairman: J. Arthur Ragsdale, 1526 27th Ave., San Francisco, Calif.

SOUTHEASTERN MASSACHUSETTS CHAPTER meets 8:00 P.M., last Wednesday of each month, home of Chairman John Alves, 57 Allen Blvd., Swansea, Mass.

SPRINGFIELD (MASS.) CHAPTER meets 7:00 P.M., first Friday of each month, U. S. Army Hdqts. Building, 50 East St., Springfield, and on Saturday following the third Friday of each month at a member's shop. Chairman: Rupert McLellan, 233 Grove St., Chicopee Falls, Mass.

NRI NEWS

3939 Wisconsin Ave.
Washington, D. C.

Forwarding Postage Guaranteed

Mr. Lester N. Rodgers
3 Water St.
Christiana, Penna.

E30-D332-G

4A

Second-class mail
privileges authorized
at Washington, D. C.