

# National RADIO-TV NEWS



## IN THIS ISSUE

Adding Short Wave to the 7W Receiver

How Amplification is Obtained with a Transistor

Build a Low-Cost Hi-Fi Amplifier

April-May  
1958

VOL. 18  
No. 2



---

---

## THE STEPS THAT COUNT

Once there were two oil well drillers who started wells next to each other on their own claims. One went to 3840 feet—found nothing—gave it up as a failure. The other drilled to 3856 feet—only 16 feet further—brought in a 10,000 barrel gusher.

When asked the secret of his success, a famous man once said, “When others slowed down, I worked all the harder.”

It always seems to hold true that the bit of extra effort—willingness to go a step further—draws a distinct line between success and a commonplace existence.

Success lies just around the corner—tomorrow; next month; next year. But it smiles only on those who will “push” themselves the few extra steps to reach it.

J. E. Smith  
Founder

# NATIONAL RADIO-TV NEWS

Theodore E. Rose, *Editor*  
J. F. Thompson, *Associate Editor*  
J. B. Straughn, *Technical Editor*  
L. L. Menne, *Editor Emeritus*

Published every other month by the National Radio Institute, 3939 Wisconsin Ave., N.W., Washington 16, D. C.  
Subscription, \$1.00 a year. Printed in U. S. A. Second-class mail privileges authorized at Washington, D. C.

## ADDING SHORT WAVE RECEPTION TO THE 5-TUBE 7W RECEIVER

By T. Carswell  
NRI Consultant

The 5-tube 7W receiver is quite familiar to those of you who have completed Kit 7W in the current Radio-Television Servicing series of kits.

This kit was primarily designed to provide experience in assembly and wiring of electronic circuits and to give you practical service experience with a typical receiver. In addition, the completed assembly, if proper care is taken in the construction, provides excellent broadcast reception in any part of the country. The results obtained with this receiver are comparable to those of any commercial model receiver of the same type. When this unit is housed in the attractive cabinet available from NRI, it makes a welcome addition to any household.

Due to increased interest in both domestic and foreign short wave reception, numerous inquiries have been received for information about modifying this receiver for use on the short wave bands. Although the original radio was not designed for this purpose, the addition of such a band is not a difficult undertaking. Such a conversion has now been made at the Institute. The completed receiver provides both short wave and broadcast reception, with very good sensitivity

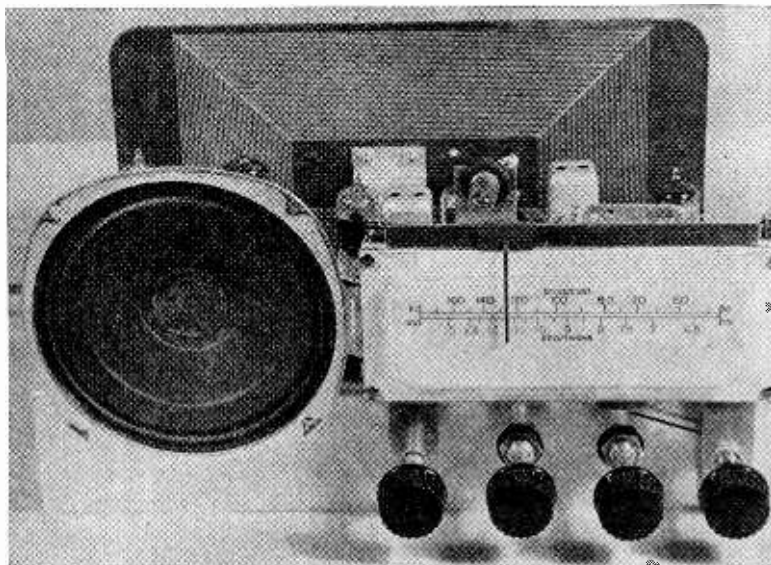

Figure 1. Front view of modified 7W receiver. Notice the four controls in place of the original two. From left to right they are—volume, tone, waveband switch, and tuning. The new dial scale is calibrated for both the broadcast and short wave bands.

and stability that is equal to normal requirements. This project should not prove at all difficult for the advanced student, and can normally be completed in a single evening if all the necessary components are on hand.

In addition to modifying this receiver for a short wave band, an inverse feedback circuit has been added in the audio amplifier. By feeding an out of phase signal back into one of the audio amplifier stages, any sound distortion that is present is greatly reduced. Of course, this results in improved sound quality. This same type of feedback circuit is employed in many high quality audio amplifiers.

A further refinement is a continuously variable tone control. Since individual tastes vary considerably, this added feature should be highly desirable in this receiver. All components employed in these modifications are standard and are available from most Radio-TV parts supply dealers. The total financial cost is small, and the added listening enjoyment will be immeasurable.

A view of the modified 7W receiver is shown in Fig. 1. Notice that there are now four control knobs in place of the original two. Reading from left to right, they are—volume-on-off switch; tone; short wave-broadcast switch; tuning. Notice also that the original dial scale has been replaced with one which has both the broadcast and short wave bands listed. A full size reproduction of this scale is shown in Fig. 7.

Before starting this project, all components shown in the parts list at the end of this article should be on hand. Otherwise, you will be unnecessarily delayed as you progress with your work. In addition to the necessary electronic components, you must have a supply of hookup wire, solder, small bolts and nuts, and the usual tools, including a small soldering iron. As each step in the assembly is completed, it is a good idea to check these points on your schematic diagram so that any wiring errors can be avoided.

By referring to Fig. 2, you will notice that a pair of insulated mounting lugs have been added on the top of the receiver chassis. These mounting lugs serve as tie points in the audio feedback circuit and the antenna circuit. These are the first components to be mounted. Fasten one of the mounting lugs on the top bracket of the speaker frame by means of a 6-32 bolt and nut. Have the insulated lug nearest the rear of the chassis. The other mounting lug must be fastened as shown on the side of the tuning condenser assembly. Examination of the frame of this condenser will show that there are three threaded mounting holes on the side of the condenser facing the nearest end of the chassis. The top rear hole is employed to mount the

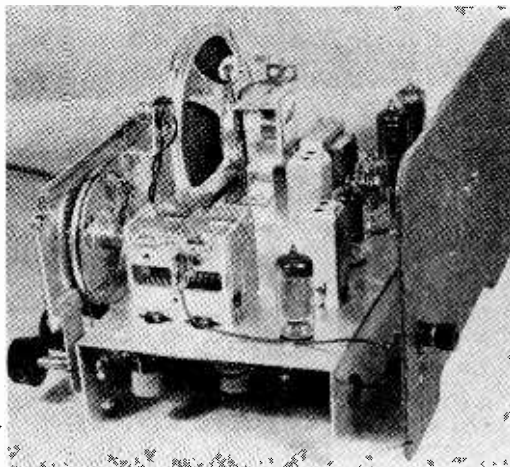

Figure 2. The mounting positions for the feedback resistor, shortwave antenna coupling condenser, and the external antenna connection are shown. The insulated mounting lugs are fastened to the top of the speaker and on the side of the tuning condenser. The external antenna connector is fastened through the original rivet on the loop antenna board.

other insulated tie point. Be sure to use a 6-32 bolt that is not long enough to short the tuning condenser. Mount this strip with the insulated lug on the bottom facing the chassis.

Again referring to Fig. 2, you will find a binding post mounted on the insulated portion of the loop antenna. In order to properly mount this binding post, you must carefully drill out the center of the large rivet that connects to the single turn of wire around the outside of the loop itself. This is necessary in order that the 6-32 bolt on the binding post will pass through this hole. After the hole is of the proper size, mount the binding post as shown, with a soldering lug placed under the mounting nut on the inside of the loop antenna board. Have the lug placed so that the connecting hole is closest to the outer edge of the antenna board.

Connect the 220 ohm,  $\frac{1}{2}$ -watt resistor between the mounting lug and the voice coil connection as shown in Fig. 2. Connect one of the 25-mmf condensers between the insulated mounting lug and the top connection of the rear tuning condenser as shown in the same illustration. The 220 ohm resistor forms a part of the inverse feedback network, while the 25-mmf condenser serves as the antenna coupler for the short wave band. Connect a length of insulated hookup wire between the other end of the 25-mmf condenser and the soldering lug on the antenna binding post.

Let's now refer to Fig. 3. You will notice that a number of wiring changes have been made in the ground circuits for the mixer and i-f stages. The original ground lead on the center shield pin of the mixer has been removed. Also, the leads between terminal 2 and all other ground points have been taken out. In order to provide the most direct connections, a length of tinned buss wire is formed as shown and soldered between the center shield connections of the mixer stage and the second detector stage. It is essential that good electrical connections be made on each of these center shields.

When the buss ground wire is securely fastened in place, connect B-wires to the buss as shown, between the broadcast oscillator coil, terminal 2, and the center shield on the i-f socket, using short bare lengths of hookup wire. These connections must be as short as possible.

The other soldering lug in your parts list must be mounted between the mixer tube socket and chassis, using the bolt through hole F. After bending the lug at right angles to the chassis, .01-mfd ceramic disc condenser is fastened between this lug and the center pin of the mixer tube socket. Since this condenser serves as an rf by-pass, these leads must also be kept extremely short.

The next step in the assembly is to mount the tone control potentiometer and the short wave-broadcast switch. Drill  $\frac{3}{8}$ -inch holes for the pot and switch, spacing them equally between the tuning shaft and the volume control shaft. Mount the assemblies as shown in Fig. 3. You will notice that there are some unused connecting lugs on the wave band switch. This is due to the fact that a 3-pole, 2-position switch assembly was not available. Instead, a 3-pole, 4-position switch had to be employed. Therefore, the remaining two switch positions are not used. In the modified receiver here at the Institute, the switch positions in the counter clockwise position of the switch were employed. Therefore, when the switch is

turned to either of the positions toward the maximum clockwise direction, the circuit is inoperative.

In order to complete the wiring for both bands in the mixer circuit, you must next construct the extra coils necessary for the short wave band. These coils are constructed on standard  $\frac{3}{8}$ -inch forms which were obtained from used rf coil assemblies. If none of these forms are to be found in your used parts, any radio service shop would probably be able to supply you at little or no cost. However, they must be of the correct diameter.

Complete coil data is shown in Feb. 6. The antenna coil consists of a single untapped winding of thirteen turns, No. 22 enameled wire. It must be close-wound tightly on the form so that the completed coil is securely anchored. If a small drill is not available, a sharp ice pick or large needle is satisfactory for punching the holes through the coil form at the beginning and end of the winding.

The same type form is used for the oscillator coil. However, this assembly has a total of 12  $\frac{1}{2}$  turns of the same type wire, with a tap provided two turns from the bottom of the coil. In order to obtain this tap, it is easier to wind the 2-turn coil first, then start the larger winding through the same hole in the coil form. Make sure that the wire ends are carefully scraped of all enamel and securely soldered to the connecting lugs.

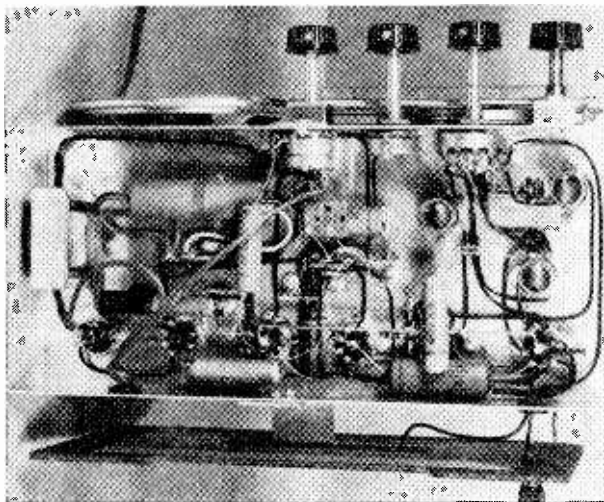

Figure 3. An underchassis view of the receiver showing the B-buss wire connection between the mixer and second detector sockets. Carefully note the short ground leads from the coils to the buss wire. Notice also that the AVC lead from the loop antenna now connects to the wave-band switch.

After the coils have been completed, both assemblies should be thoroughly coated with a good coil dope so that the windings will not be affected by moisture. In addition, this will prevent any shifting of the windings which will affect the calibration of the receiver. Of course, make sure that the coil dope does not run down over the soldering lugs.

Four new mounting holes will now have to be drilled in order to secure the short wave coils in place. Again referring to Fig. 3, mount the coils as



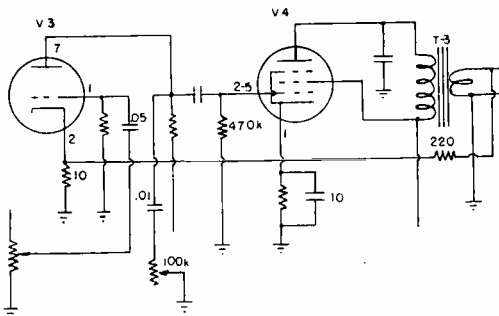

Figure 5. A number of circuit changes have been made in the audio section of the receiver. These modifications provide a variable tone control, in addition to an improvement in sound quality.

through. The original metal dial plate is removed from its mounting on the chassis and the new scale and cardboard backing are cemented in place on the reverse side of the metal scale. This will avoid any damage to the broadcast scale that is now embossed on the plate.

The most satisfactory means for obtaining the new dial face is to carefully trace Fig. 7 (page 8) onto another sheet of plain paper, or a thin piece of cardboard. For the sake of appearance, separate colors may be used to separate the broadcast and short wave scales. For example, the broadcast calibration may be marked in black ink, and the short wave marked in red ink. If a cabinet is used to house the receiver, corresponding dots should be marked on the front panel of the cabinet by the wave band knob so that the proper band will be indicated when the knob is turned from one position to the other.

Basically, the tuning of the receiver for short wave reception is the same as that for the broadcast band. However, due to the much higher frequency of operation, the tuning is far more critical. Extreme care must be used when tuning through the short wave bands, as even powerful stations can easily be passed over if the tuning dial is turned rapidly.

As you tune across the short wave dial, you

## ELECTRONIC BRAIN—?

One housewife remarked to another:  
*"I got to thinking the other day—you know how it is when the television set isn't working."*

NYC Chapter

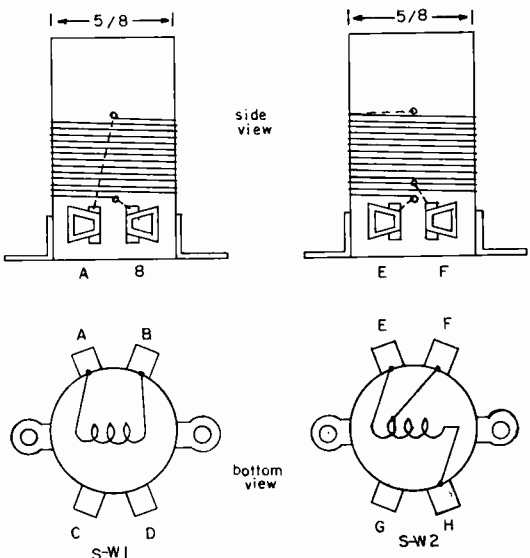

Figure 6. Complete coil data for the shortwave bands. The coil forms must be  $\frac{5}{8}$ -inch diameter. The wire used is #22 enamel covered. The antenna coil consists of 13-turns, while the oscillator coil is  $12\frac{1}{2}$ -turns with a tap placed 2-turns from the bottom of the winding.

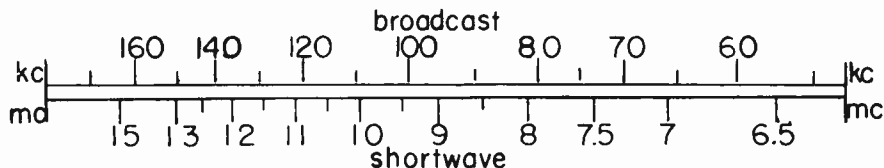

Figure 7. This is a full-size reproduction of the new dial scale for the completed receiver. This may be cut out and glued on a thin piece of black cardboard and fastened to the original metal dial scale.

#### ADDITIONAL PARTS FOR MODIFICATION

- 1 .01-mfd ceramic disc condenser
- 1 .01-mfd paper condenser
- 1 .05-mfd paper condenser
- 2 25-mmf tubular mica condensers
- 1 10-mfd, 25-volt electrolytic condenser
- 1 10-ohm, 1/2-watt resistor
- 1 220-ohm, 1/2-watt resistor
- 1 470K-ohm, 1/2-watt resistor
- 1 100K-ohm pot
- 1 3-pole, 2-position rotary switch, shorting type
- 1 antenna binding post
- 2 5/8-inch diameter coil forms
- 1 5-foot length #22 enamel wire
- 1 6-inch length tinned buss wire
- 3 single insulated lug mounting strips
- 2 soldering lugs

### New High Perveance Beam Power Tube Introduced by RCA for Commercial and Amateur Equipment

A New high-perveance beam power tube with high power gain has been introduced by the RCA Electron Tube Division—type RCA-7094.

This compact tube is designed for use as radio-frequency (rf) power amplifier, oscillator, audio frequency (af) power amplifier, and modulator in commercial and amateur equipment.

In continuous-wave service, the 7094 can be operated with 500 watts input (intermittent commercial and amateur service) at frequencies up to 60 Mc and with reduced input up to 175 Mc. It has a maximum plate dissipation of 125 watts (ICAS) in modulator and CW service.

Because of its high power gain, the new tube can be operated with relatively low plate voltage to give large power output with small driving power. Of particular interest is the use of the 7094 as a linear rf power amplifier. In class AB<sub>1</sub>, single sideband, suppressed carrier service with single-tone modulation, this new tube is capable of giving a maximum signal useful power output of approximately 250 watts when operated at 60Mc, under ICAS conditions with a plate voltage of 2000 volts.



WIDE VARIETY of hi-fi components available to hobbyists and music lovers is shown by this complete grouping of products in line of just one company—General Electric. G. E. believes it has the broadcast components line in the industry. Front, center, are 23 different styli, nine different cartridges. Right front are rumble and record filter and two tone arms; left front are two preamplifiers. Center is 20-watt amplifier. To rear left are six different speakers (three wide-range, a dual coaxial, woofer, and tweeter) and audio crossover network. At rear are equipment cabinet and 12-inch and eight-inch speaker enclosures. G. E. has been in hi-fi components business since introduction of its magnetic variable reluctance cartridge in 1946.

*If a man can afford to sit down and wait for a golden opportunity—he doesn't need it!*



# HOW AMPLIFICATION IS OBTAINED WITH A TRANSISTOR\*

By J. B. STRAUGHN  
Chief, NRI Consultation Service

Many students, and old timers, who thoroughly understand the operation of the vacuum tube are just as thoroughly confused by transistor action.

This sad state of affairs is the result of attempting to think of transistor operation in the light of their tube knowledge and by the fact that most transistor theory has come from the mind of the research engineer directly, without the necessary transition to the type of thinking done by the technician. In this article we will attempt to bring out the facts which you, as a technician, must know in order to see how amplification with a transistor takes place. Here we will not attempt to give a complete story of the inner workings of the transistor or of all transistor amplifiers, but we will try to show what makes amplification possible.

Our prime purpose is to tell how a transistor gives an increased signal voltage and an increase in signal power.

First let's consider a few known basic facts about voltage, current, and power.

Voltage is equal to current x resistance. If the current remains constant and the resistance is increased, the voltage drop across the resistance is increased.

Power is equal to current x current x resistance. If the current remains constant and the resistance is increased, the power present in the resistor is increased.

Ohms law tells you that if the current remains constant and the resistance is increased the source voltage must increase. With a transistor this fact is side stepped and as you will

---

\*Written especially for those who have learned how amplification can be obtained with a vacuum tube, and who have a good understanding of Ohm's Law.

see, we accomplish this desirable result without increasing the *original* source voltage.

If we can switch a current from a low resistance circuit into a high resistance circuit without an appreciable change in the value of the current, we will automatically get an increase in voltage and an increase in power. This is just what is done in one type of transistor amplifier. To show how this seemingly impossible fact is possible it will be necessary to review current and see what it is and how it flows through a circuit.

In a metallic conductor such as copper you know that the current consists of a movement of free electrons through the wire. The technician generally thinks that moving electrons are current. Actually the current is a moving charge, which is part of the electron. Current does not necessarily have to be a movement of electrons. In a gassy vacuum tube we have positive charges (an ion with a missing electron) moving from positive to negative. This too represents a flow of current, and if the ion current bridges the gap between two metallic objects kept at a difference in potential by an external circuit, the number of electrons that will flow in the external circuit assuming the voltage is quite high, is governed entirely by the number of ions that bridge the space between the conductors rather than the exact value of the applied voltage. If we had some way of injecting these ions into the gap between the conductors we could control the current in the external circuit.

The production of ions in a vacuum is a rather haphazard affair and cannot be controlled. However, a different situation exists in certain semiconductors, particularly specially prepared germanium. Two types of germanium are used, one which has positive charge carriers and one which has negative charge carriers.

In a germanium diode, as in any rectifier, we can get a large current flow when voltage of the correct polarity is applied, the positive and negative charge carriers working together. If the voltage is reversed no current will flow because a small area of the two materials forming the junction of the diode are swept clear of current conductors. These conductors or carriers are free electrons and holes. A hole is the equivalent of a gas ion—a germanium atom with a missing electron.

This atom cannot float around in the germanium crystal structure like a gas ion. What happens is that a "fixed" electron from another atom may jump into the hole and the atom from which this electron was attracted now has a hole in its structure. Thus the hole position will move through the germanium towards the negative side of the external circuit, passing

electrons towards the positive side of the circuit during its drift. The hole will cease to exist on reaching the negative side of the circuit, but a new hole will be formed at the positive side of the crystal and the process will be repeated. When the applied voltage is of the wrong polarity (reversed bias), to permit current flow, the holes are repelled from the junction as are the free electrons, so there is nothing to carry current from one of the diode materials to the other.

However the reversed voltage across this diode is "raring to go" and wants to push current around the circuit, but the complete path is

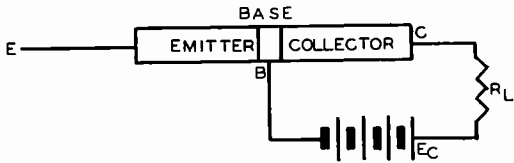

Figure 1. A transistor in block form. The emitter and the collector are made of germanium which contain negative carriers (free electrons) and is therefore called N material. The base is made of material containing positive carriers (holes) and is for that reason called P material. The base is only a few thousandths of an inch thick. When the materials are arranged in this manner the resulting transistor is called a NPN type.

blocked by the non conductive region which is barren of current carriers.

It is possible to inject or emit a controlled number of current carriers into this barren region and then current will flow through the external circuit and through all of the parts in this circuit. Because the external voltage is high it can sustain any practical current that is injected into the barren region. If current carriers for 5 ma are injected then 5 ma flows in the external circuit. If 20 ma worth of carriers are injected then 20 ma will flow. Let's see how these controlled current carriers can be emitted into the carrier-free area of a transistor.

A typical transistor in block form is shown in Fig. 1. There are three leads from the transistor, the emitter lead E, the base lead B, and the collector lead C. The collector and base are reverse biased and the junction of the base and collector have been swept clean of current conductors. For this reason no current flows through load resistor  $R_L$ , and the collector is hungry for current carriers.

In Fig. 2 we have completed the emitter circuit by connecting a small resistor and battery between the emitter and the base. The emitter and base are biased in a forward direction so electrons flow from the negative

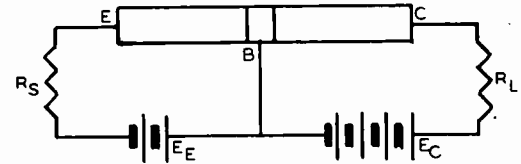

Figure 2. Here the emitter is biased in a forward direction and since current carriers are available at the junction of the emitter and the base current can flow from the emitter into the base.

terminal of  $E_B$  through  $R_B$ , and into the emitter. You might expect an equal number of electrons to flow out of the base and back to  $E_B$ . This however does not occur. The base is made of material so thin as to be porous; and when current carriers are injected into it by the emitter, these carriers are snapped up (collected) by the collector, flow through load resistor  $R_L$ , source  $E_C$  and are then returned to  $E_B$ .

An important point is that changing the value of  $R_L$  will have little effect on the current flowing through it. Because of this  $R_L$  may have a much higher resistance than  $R_B$ . Therefore since the current through  $R_L$  is essentially the same as the current through  $R_B$ , the voltage and power across  $R_L$  is greater than the voltage and power across  $R_B$ .

If we replace  $R_B$  with an ac signal source such as a microphone the signal voltage will alternately add to and subtract from the bias voltage  $E_B$ . This will vary the emitter current, the injection of current carriers into the base, and the voltage across  $R_L$ . Thus the transistor will provide amplification.

The internal action of a transistor is a study in itself as are the various circuits which can be used. In every case, however, current carriers which complete a potentially high current circuit are emitted into the collector and essentially the same current flows in a circuit with more resistance than the source. As a result a gain in voltage and power occurs.

Details of the interior working of transistors and transistor circuitry will be found in the regular lessons of the NRI Servicing course.

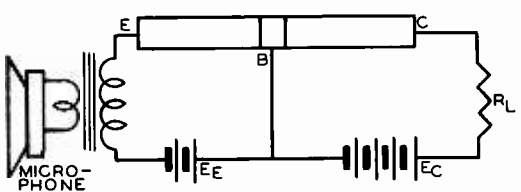

Figure 3. Signal currents from the low resistance microphone transformer will flow through the high resistance load  $R_L$  producing a large signal voltage.



J. G. Dodgson

The amplifier described in this article, although designed for a low cost high fidelity system, is actually quite similar to many high cost high-fidelity amplifiers. The main difference is that certain costly components used in premium amplifiers were replaced with less expensive components in this amplifier. For example, the main saving is in the output transformer. 24-Watt replacement type output transformer was used which costs approximately \$2, whereas premium amplifier output transformers generally cost from \$15 to \$40. A smaller and less expensive power transformer was chosen for the unit keeping the power output of the amplifier down to about 7 Watts. Incidentally, this is more than enough power for most small H.F. systems since the speakers used in such systems seldom have power ratings over 6-8 watts.

A substantial saving was accomplished by not providing a magnetic cartridge preamplifier since low cost high fidelity systems almost always use one of the less expensive high fidelity ceramic cartridges in the phonograph.

The other circuitry in the unit, however, resembles premium amplifiers closely. For example, the tone control circuit is of the Baxandall feedback type used in the most expensive amplifiers.

One interesting feature of this amplifier is that it can be considered to be a progressive type since certain parts can be changed to improve the quality without upsetting the other circuitry. The power transformer high voltage secondary has a current rating of 70 ma. At any time, this power transformer can be replaced with one having a secondary current rating of 90 or 120 ma. and by merely removing the 500-ohm resistor (R24) increase the plate voltage the amplifier output will be boosted to 10 to 12 Watts.

# HOW TO BUILD A LOW COST HI FI AMPLIFIER

By J. G. DODGSON

NRI Consultant

No other circuit changes are necessary to provide this increase in power. Similarly, the inexpensive output transformer could be replaced at any time with a high fidelity output transformer with no circuit changes other than the values of feedback resistor R15 and condenser C8. If desired, the ceramic cartridge in the phonograph could be replaced with a better magnetic-type cartridge and then a separate preamplifier could be purchased and merely plugged into the input jack of this amplifier without any circuit changes. More about this later.

Despite the low cost of the unit, and especially the output transformer, surprisingly good results are obtained. Frequency response is flat within 1 db. from 50 cycles to 15,000 cycles and is only 2 db. down at 20,000 cycles. Due to the relatively low primary inductance of the output transformer, the response falls off rather sharply below 50 cycles, but yet is only 5db. down at 20 cycles (remember that the ear can just about hear a 3 db. change of sound level).

The hum and noise from the unit are inaudible at normal playing levels. Even with the gain control turned fully on and the bass and treble controls turned to full boost, the hum and noise level are acceptably low. In fact, the hum level is inaudible 3 or 4 feet from the speaker under this extreme condition.

The bass and treble controls in the unit provide approximately 12 db. of either boost or reduction at 50 and 10,000 cycles respectively. Since the gain control is connected at the input of the unit, it is not possible to unintentionally overload the input stage. With the gain control turned fully clockwise, the amplifier requires only .14 volts for full output. This is more than adequate gain since the ceramic cartridges, for which it was designed, have an average output of .5 volts. The power amplifier itself requires approximately 1.7 volts for full output. It can be used, of course, with any preamplifier than can

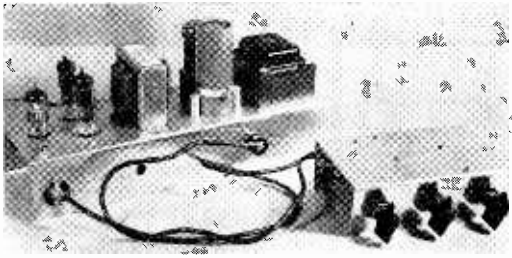

Fig. 1. Side view of the amplifier and preamplifier chassis.

supply this output or with a tuner, providing the tuner has its own volume control.

As seen in Figures 1 and 2, the amplifier and preamplifier were built on separate chassis which were made from sheet aluminum. This aluminum is available in large sheets from many radio jobbers or the Reynolds "Do It Yourself" type aluminum sold at most hardware stores can be used. It is also possible to purchase standard radio chassis bases from radio wholesalers for the amplifier and preamplifier.

The amplifier described here is built on a chassis 12 inches long, 4 inches wide, with 2 inch sides while the preamplifier chassis is 6 inches long, 4 inches wide, and also has 2 inch sides. As can be seen in the illustration, no attempt was made to miniaturize the units and plenty of room is left to spare in both units for the substitution of other parts in the future. This also provides adequate ventilation.

Of course, it is not necessary to build the system on two separate chassis. This was done since eventually the equipment will be placed in a phonograph cabinet and it will be more convenient to have it on two separate chassis. If, however, the unit is built on one chassis it is essential that the 12AX7 input tube be kept as far away as possible from the power transformer to prevent hum pickup. In this case the use of a shielded type tube socket for the 12AX7 is recommended.

With the amplifier built on two separate chassis it is necessary to use a cable to supply power to the preamplifier chassis as well as to use a separate audio cable to couple the output signal of the preamplifier to the input of the power amplifier. Standard plugs and cables are available at most radio

wholesalers. Although the author was able to obtain a 4-prong socket and its corresponding 4-prong plug for the power cable any type of plug and socket can be used if they provide for at least 4 prongs. To prevent hum pickup, the audio output signal of the preamplifier must be fed through a separate shielded cable to the power amplifier.

If a standard chassis base are used, it will not be possible to obtain the exact sizes mentioned above—which is one reason the author made his own. However, satisfactory sizes are available. The power amplifier can be built on an open-end chassis  $1\frac{1}{2}$ " x 11" x 7" such as Bud type CB-997 and the preamplifier can be built on a  $1\frac{1}{2}$ " x 7" x 5" Bud CB-30. Similiar sizes are also available in ICA chassis bases.

As the experienced "do-it yourself" in electronics knows, there are many tricks of the trade that can help in building equipment such as this amplifier. Naturally, there are also some pitfalls that can cause grief.

The first step is to gather the material—the sheet aluminum or chassis bases, and all the electronic components and hardware. Then obtain a piece of paper large enough to cover each chassis. This is to be used as template. Brown wrapping paper is fine for this—if none is handy, cut up a large paper bag. Then cut the paper to the same size as the chassis including the sides of the chassis.

Next, sit down with all of the parts and the paper and arrange the parts on the paper just as you will place them on the chassis. By doing this it is possible to place all of the parts in their most convenient positions. It is not possible, of course, to obtain a perfect layout by doing this since you are working with a two dimensional piece of paper while the chassis construction itself will be three dimensional. However, very satisfactory results can be obtained by using this method. The paper itself

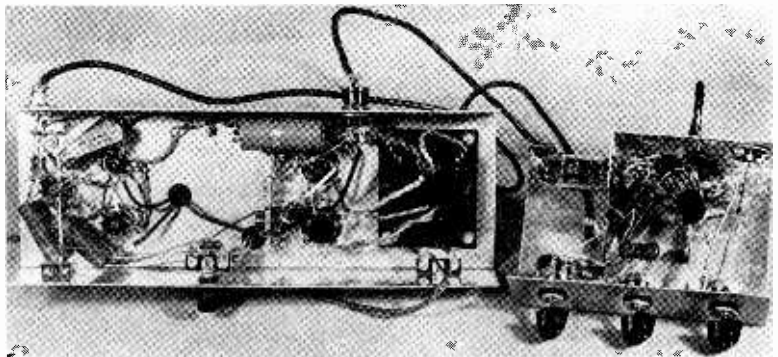

Fig. 2. Bottom view of the amplifier and preamplifier chassis.

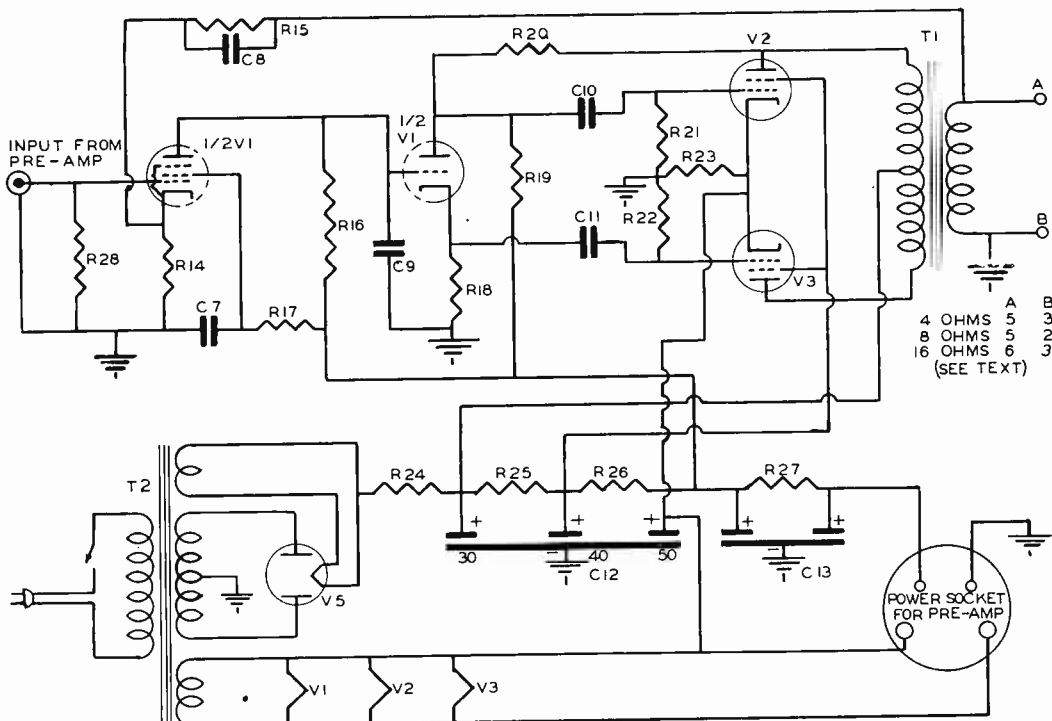

Fig. 3. Schematic diagram of the power amplifier and power supply.

can be marked with pencil for the holes that are to be drilled and then the paper can be taped to the chassis and the holes drilled through the paper and the chassis.

After the layout is decided upon, the next step is to prepare the chassis.

If sheet aluminum is used to make the chassis, you have the choice of cutting the chassis before it is bent or bending it before it is cut. It is easier to cut the chassis before it is bent but this makes it harder to get a good bend. It is up to the builder as to which he prefers to do first.

There are a great number of specialized tools that simplify making chassis. Unfortunately, such tools are not usually available to the ordinary man since they are expensive and are seldom used. Small chassis can be nicely bent in a vice or even on a table top with the help of several pieces of hardwood. The wood should be as long as the chassis, of any thickness over 1/2 inch, and three or four inches wide. Two such pieces of wood can be inserted in the vise horizontally and the chassis placed between the pieces of wood. A third piece of wood of the

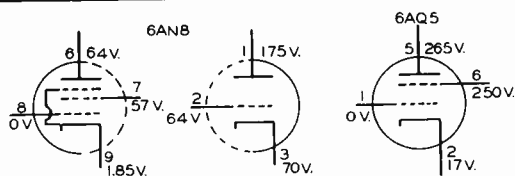

same size can then be used to bend the chassis or it can be bent by hand. After the initial bending, the bend itself can be better formed by hammering it with a rubber mallet. An ordinary hammer can be used if a piece of wood is placed over the chassis and the wood is hit with the hammer—this prevents marring the chassis.

Large holes in a chassis such as for a power transformer can be cut with a key hole saw by first drilling holes to start the saw or the hole can be cut with a chisel and hammer. Tube socket holes are normally cut with chassis punches which are available from most radio wholesalers. The holes can also be cut with a drill and reamer. Turning out a fine production quality chassis does require some amount of mechanical skill. However, even the rankest novice can produce a satisfactory chassis with a little planning and patience.

Although no special layout is required for the

power amplifier and power supply section, the one used by the author is a well tested layout employed by a great number of commercial amplifier manufacturers. The first pentode stage in the power amplifier has high gain and it is therefore essential to wire it neatly. In fact, to reduce hum pickup and other such problems it is important that the entire power amplifier be built neatly. Notice that the filament wiring is tightly twisted—this is essential. All hookup wire and resistor and condenser leads should be cut as short as practical and you should carefully tin each lead before it is soldered in place. Notice that a buss bar is connected from the ground side of the input jack to a terminal strip on the opposite side of the chassis. All ground connections in the 6AN8 and 6AQ5 tube stages are brought to this buss bar to eliminate the possibility of a ground loop. All of the grounds in the power supply section are also made at one point—a ground lug on the 5Y3 tube socket. The single ground connection in the power supply is not essential but a single ground connection in the power amplifier section should be used. A piece of buss bar is not necessary—any terminal could be used but the buss bar is convenient.

After building the power amplifier and the power supply section, it should be tested separately. Before applying power to the unit an ohmmeter check should be made from the 5Y3 tube filament to ground. Since there are no bleeder resistors in the power supply a reading of 500,000 ohms or higher should be obtained depending on the exact leakage resistance of the electrolytic filter condensers. Any reading below this should be checked out. An extremely low reading would probably indicate an error in wiring or a ground caused by excess solder running down from a terminal to chassis or bridging the gap between two terminals.

Notice that one side of the filament winding is shown connected to the cathodes of the 6AQ5 output tubes. This places a positive bias on the filament supply to keep down the hum level by minimizing heater to cathode leakage. In the particular amplifier built by the author, it didn't matter which side of the filament supply was connected to the cathodes. However, sometimes connecting one side will reduce the hum more than connecting the other side. This should be tried after the preamplifier is built. Due to the high signal level in the power amplifier unit, this bias connection may not make any audible difference until the preamplifier is in use.

Should the ohmmeter check prove satisfactory, power can be applied to the unit. Before doing this, however, connect the loudspeaker voice coil to the output transformer. Be sure that one side of the output transformer secondary is connected to ground. As indicated in the schematic

diagram, different taps are used in the output transformer to match any voice coil load impedance.

A speaker connected to the output terminals should reproduce almost no audible hum two or three feet away. If excessive hum is encountered, check the wiring and soldering and be sure the electrolytic condensers are in good condition. Further checks can be made by measuring the operating voltages and comparing them to those shown below Fig. 4. Due to variations in parts values and line voltage, a variation of 20% can be expected.

The method of mounting the tube makes the layout of the preamplifier a little unusual. Of course, the tube need not be installed this way at all. It can be mounted on top of the chassis or on the back (with the socket lugs facing the backs of the potentiometers). If the socket is mounted as shown be sure to wire the filament first. Then wire the lugs near the back of the chassis. It is also more convenient to wire all of the resistors first and to wire in the larger coupling capacitors last.

It is important to keep the wiring neat and to use a common ground point. Remember that the preamplifier contains high gain, low level stages and a slight amount of hum picked up by the wiring will be greatly amplified. Notice the buss bar connected to the chassis at the phonograph input jack is used for all ground connections. The filament wires must be tightly twisted. Be sure to keep all hookup wire and resistor and condenser leads as short as possible and to tin each lead before soldering.

After the preamplifier unit is built check it for possible shorts and correct wiring with an ohmmeter, using the schematic in Fig. 4 for reference, before connecting it to the amplifier chassis. If these checks prove satisfactory, turn off the power amplifier section and then plug the preamplifier power cable and audio cable into the amplifier chassis socket. Then turn on the power and check the B+ in the preamplifier chassis. If B+ is not obtained or if the tube does not light up, check the wiring to the power socket in the amplifier chassis as well as the plug at the end of the power cable from the preamplifier chassis. A loose connection at either of these points is the usual cause of such trouble.

Should B+ be obtained in the preamplifier chassis and the tube light up, temporarily ground the input jack with a piece of wire and turn the volume, bass, treble controls fully clockwise. Hum and noise should then be slightly audible right at the speaker and should disappear four or five feet away from the speaker. The noise should actually be higher than the hum level. Incidentally, if the filament supply is not connected to the 6AQ5 cathodes in the

amplifier chassis, a loud hum may be obtained. Try connecting first one side of the filament supply to the cathode and then the other and use the one that gives the lowest hum. As mentioned before, you may not notice any difference.

Should the hum still persist, check all of the ground connections and make certain that a single ground point was used in both the pre-amplifier chassis and the power amplifier chassis. A loose or poorly soldered connection is probably the most common cause of hum. It is also possible that the 12AX7 input tube has slightly higher cathode to heater leakage than normal—try another tube. You might also try another 6AN8 tube in the power amplifier chassis.

The effectiveness of the tone controls will depend on the remaining sections of the high fidelity system. For example, if a loudspeaker is used that cuts off abruptly above 7000 or 8000 cycles then the treble control action will not be as noticeable as with a fuller range system that extends, say, to 15,000 cycles. The same, of course, applies to the bass control.

As mentioned previously, some of the parts can be changed in this unit to improve the system. A Crest type PF 16 power transformer was used. If this is not available a Stancor type PC-8408 can be used. The output transformer is a Merit type A-2905.

The power transformer has a high voltage secondary rating of 800 volts center tapped with a current rating of 70 Ma. To obtain more power output from the unit, the transformer can be replaced with one having a high voltage secondary rating from 700 to 900 volts with a current rating from 90 Ma. to 120 Ma. When this is done the 500 ohm resistor R24 should be removed or changed according to the limits of the power transformer. This resistor is used solely to reduce the plate and screen voltages of the 6AQ5 tubes and thereby limit the power drain on the transformer to prevent overloading it. The current drain can easily be measured by inserting a milliammeter IN SERIES with the B+ line at the 5Y3 tube socket or the voltage can be measured across the 500 ohm series resistor and Ohms Law used to compute the current drain. For example, if a 90 Mil. transformer is installed, the 500 ohm resistor would need to be reduced in value. Connect the meter to check the current drain on

the transformer and reduce the resistor until the current drain reaches about 80 to 85 milliamperes with the preamplifier connected to the power amplifier chassis but with no signal input. Then, check the current drain with a signal input from a phonograph or tuner. The current should not rise above 90 mils. If it does, increase the series resistor.

The power transformer should also have a 5-volt, 2-ampere winding for the 5Y3 tube and a 6.3 volt winding with a current rating of 1.65 amperes or more. The filament current ratings do not change no matter which type power transformer is chosen.

Notice in the diagram the different taps on the transformer needed to provide different impedances according to the speaker impedance used with the system. Be sure that the indicated terminal is connected to ground as shown in the diagram or the feedback will become positive and will cause oscillation. If oscillation does occur, reverse the connections to the secondary

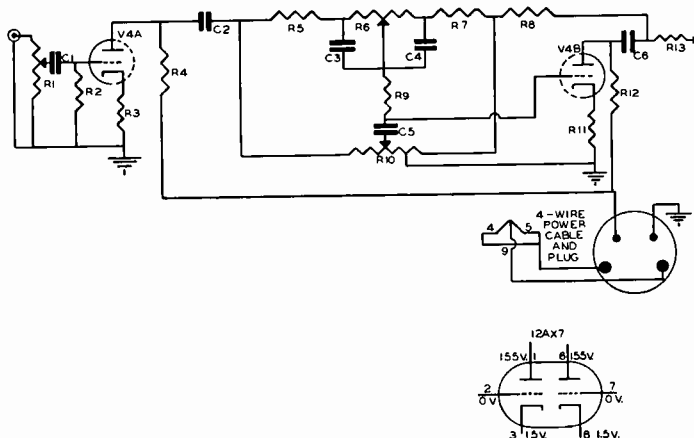

Fig. 4. Schematic diagram of the pre-amplifier.

winding of the output transformer. It is possible for a transformer winding to be wound backwards once in a while. Incidentally, the author tried all impedances from 4 ohms to 16 ohms and tests with a square wave generator and oscilloscope showed that the feedback did not need to be changed when going from one impedance to another.

By the way, the bass control specified in the article was not available when the author built the unit although it was listed in the catalogs. This is a ½ megohm linear taper potentiometer with a center tap. If it is not available, a 1 megohm linear taper potentiometer can be used

(Continued on page 18)

# NRI PROFESSIONAL MODEL 70 TUBE TESTER

—A Favorite With NRI Men Everywhere

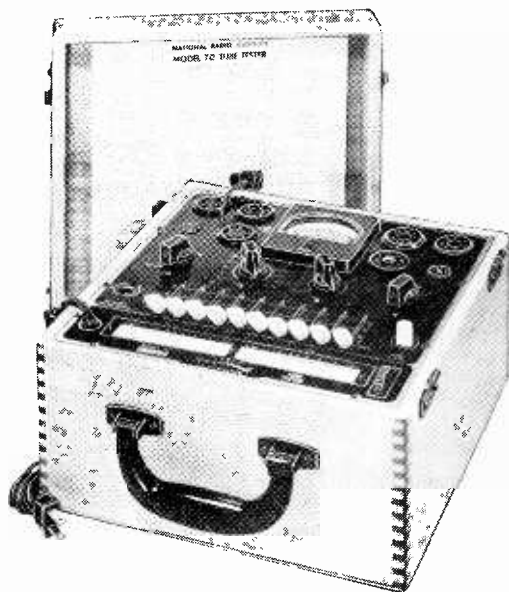

STILL  
ONLY **\$49.75**

## TV Picture Tube Adapter

OPTIONAL ACCESSORY



May be used with all NRI Professional Tube Testers, Models 66 through 70. (Not usable with NRI Model 1185.) This Adapter enables you to test a Television picture tube in a receiver, or in the original factory carton. The test includes a cathode emission check and a check for shorts between the various elements in the tube. There are certain comparatively infrequent troubles in picture tubes which an Adapter will not detect. It is, nevertheless, a popular and useful accessory.

Only **\$4.98**

Complete with instructions. Shipped parcel post, prepaid. Order blank on page 17.

Page Sixteen

## CHECK THESE SPECIFICATIONS

**Employs Standardized RETMA Emission Test Circuit**—Ten separate four-position tube element switches make tube prong connections flexible—take care of future electrode connections.

**Eight Tube Test Sockets**—Tests 4, 5, 6, 7, and 7L prong tubes; plus octal, loctal, 7-prong miniature; and 9-prong miniature tubes.

**Tests Electric Eye and Gaseous Rectifiers.**

**Sixteen filament Voltages**—0.75, 1.5, 2, 2.5, 3.3, 4.2, 5, 6.3, 7.5, 12.6, 18.9, 25, 35, 50, 70, and 110 volts; filament voltages for all receiving tubes.

**Double Jeweled D'Arsonval Meter Movement**—Three inch;  $\pm 2$  accuracy.

**Short and Leakage Test**—Between all elements while tube is "hot."

**Value Test**—Reads directly BAD, ?, or GOOD. Meter is calibrated for comparison tests. Separate "diode" scale.

**Manual Line Voltage Adjustment**—uses test meter as a voltmeter.

**Separate Tests for Multi-function Tubes**—Individual tests for each diode in full-wave rectifiers. Separate checks on each section of multiple tubes.

**Filament Continuity Test and Open Element Test.**

**Handsome Professional Looking Harwood Case**—Beautiful natural grain, clear lacquer finish. Glued lock-corner construction. Size:  $10\frac{1}{4}$ " x  $10\frac{1}{4}$ " x  $6\frac{1}{4}$ ". 14 gauge, etched aluminum panel, black enamel field.

**Actual Weight**—11 pounds. Shipping weight 13 pounds.

**Power Requirements**—50-60 cycle, 110, 120 volts A.C. required. (Cannot be operated on D.C. or 25 cycle A.C.)

**High Speed, Double Window Roll Chart.**

**Standard 90 day, RETMA Parts & Labor Warranty.**

**Detailed Instruction Manual**—Included with each tube tester.

(Use convenient order blank on page 17)



# NRI PROFESSIONAL MODEL 89 SIGNAL GENERATOR

—For AM-FM-TV Alignment And Trouble-Shooting



**OUTSTANDING  
BUY AT \$45.00**

## TEN STAR FEATURES

- ★ Designed for Rapid, Easy Alignment of Receivers
- ★ Gives Greater Accuracy in Alignment
- ★ Wide Frequency Coverage
- ★ Six Carefully Chosen Frequency Bands
- ★ Quickly Isolates a Defective Stage
- ★ Checks Audio Amplifiers with Ease
- ★ Single Coaxial Output Jack with Detachable Coaxial Lead
- ★ Coarse and Fine Attenuation
- ★ Reliable Marker for Use with TV Sweep Generator
- ★ Complete Instruction Manual

## SPECIFICATIONS

**Power Requirements:** 50-60 cycle, 110-120 volts A.C. required.

**3 Vacuum Tubes Included:** 1—6BE6; 1—6SN7; and 1—5Y3.

**Frequency Coverage 170 Kc. to 60 Mc.**

- Band A; 170 Kc. to 550 Kc.
- Band B; 550 Kc. to 1600 Kc.
- Band C; 1.6 Mc. to 5 Mc.
- Band D; 5 Mc. to 15 Mc.
- Band TV1; 15 Mc. to 30 Mc.
- Band TV2; 30 Mc. to 60Mc.

**Planetary drive tuning condenser**—eliminates back-lash, ratio 6:1.

**Permeability-tuned R.F. Coils**—on all six bands. Highly stable ceramic trimmers used on all bands. All coils not in use are automatically shorted.

**Three Types of Signals Available:** Unmodulated R. F., Amplitude Modulated R. F., and 400 Cycle A. F.

**Coarse and Fine Attenuation.**

**Flexible Coaxial Output Cable**—with Amphenol connector.

**Actual Weight:** 12 lbs. **Shipping Weight:** 15 lbs.

**Sturdy Maroon Crackle Finish Case:** Size 12" x 8 1/4" x 10 1/4"; handsomely etched aluminum panel.

**Shipped Complete with Instruction Manual.**

## —ORDER BLANK—

**National Radio Institute, Supply Division**  
3939 Wisconsin Ave.  
Washington 16, D. C.

I enclose \$. . . . . (money order, check, or bank draft). Send me the following material:

- NRI Model 70 Tube Tester—\$49.75
- Picture Tube Adapter for Model 70—\$4.98
- NRI Model 89 Signal Generator—\$45.00
- Tell me how I can buy this equipment on easy terms.

Name . . . . . Stu. No. . . . .

Address . . . . .

City . . . . . Zone . . . . . State . . . . .

Express Office . . . . .

(If you live in Washington, D. C., add 2% for D. C. Sales Tax)

(Continued from page 15)

by connecting a 470,000 ohm resistor to each outside terminal and then the free end of the resistors connected together and to ground.

It would, of course, not be possible to completely review all of the different types of equipment suitable for use with this amplifier. However, the following suggestions may help you. Remember that a low cost amplifier naturally belongs with these similar inexpensive components.

#### Turntables and Changers.

Dollar for dollar, the best buy in quality is very probably the Garrard Model TMK for about \$32. For those preferring an automatic changer, a Webcor or Garrard is recommended. Some good buys can often be obtained in the imported Collaro or Monarch changers at local wholesalers or from mail order houses.

**Phono cartridges.** As previously mentioned, the input of the preamplifier was specially designed to match the high fidelity type ceramic cartridges used in most low cost H.F. systems. This specifically includes the Electro-Voice Models 84 and 86 and the Sonotone series 3. Both of these are very good cartridges with the Electro-

Voice a little better than the Sonotone but costing a bit more.

**Speakers and Enclosures.** To keep down the cost of the system it is best to limit the speaker size to 8 inches. A very good buy, used by the author, is the Philips Norelco (about \$11). For top quality the J. B. Lansing D-208 is recommended but it costs about \$28.

All of the above speakers can be improved by adding a small inexpensive tweeter such as the Lafayette SK-87 or HK-3. An elaborate crossover network is not necessary. A 2 Mfd to 6 mfd paper capacitor in series with the tweeter is usually quite satisfactory.

The speaker enclosure is just about as important as the speaker itself. The Karlson 8K kit enclosure is highly recommended. There are a great many other enclosure kits of the R-J, bass-reflex, and corner horn type available that

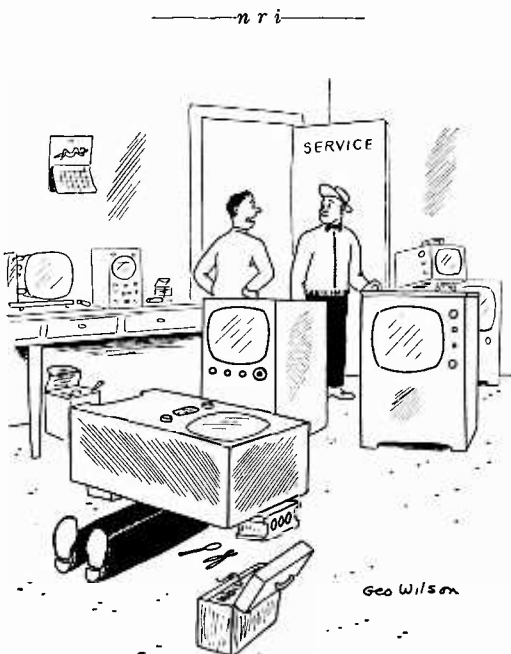

"About that auto mechanic you hired...."

## PARTS LIST

V1	6AN8
V2, V3	6AQ5
V4	12AX7
V5	5Y3
T1	Output Transformer Merit A-2905 (see text)
T2	Power Transformer Stancor PC-8408 (see text)

All resistors 1/2 watt, 10%, unless otherwise noted

R1	3 Meg pot. Audio Taper
R2, R21, R22, R28	470K
R3, R11, R14	2.2K
R4, R12	100K
R5, R7, R8	68K
R6	1 Meg pot. linear taper
R10	.5 meg. pot. linear taper, center-tapped
R13	33K
R15	10K
R16	220K
R17, R20	1M
R18, R19	51K, 5%
R23	310, 7 watt
R24	500, 5 watt
R25	4.7K, 1 watt
R26, R27	4.7K
C1	.25 MFD, 200V
C2, C6, C7	.1 MFD, 200V
C3, C4	.003 MFD, Disc
C5	100 MMF, Mica or ceramic
C8	200 MMF, Mica or ceramic
C9	390 MMF, Mica or ceramic
C10, C11	.1 MFD, 400V
C12	30-40-50/450-350-25, Sprague TVL 3723
C13	8-8 MFD, 450V

can be successfully used.

Incidentally the above opinions of specific components are solely the author's and do not necessarily reflect the opinion of National Radio Institute. The list is not intended to be considered complete but rather indicates only the components personally tested and examined by the author.

Footnote: The components mentioned in this article are available from your local wholesaler or from these mail-order houses:

Allied Radio Corp., 100 N. Western Ave., Chicago 80, Ill.

Lafayette Radio, 165-08 Liberty Ave., Jamaica 33, N. Y.

— n r i —

— n r i —

## LIVE TRANS-ATLANTIC TV

Live TV programming across the Atlantic may become a reality in 1959. Plans are to relay signals across the Atlantic land masses using sixty foot antennas. Pictures can now be sent 200 miles. Stretching this an additional 100 miles is all that is needed to span the remote ocean land masses.

— n r i —

— n r i —

## A New Slant On Vacuum Tube Amplifiers

*reprinted from the October-November 1955, issue  
of National Radio-TV News by popular request.*

THE statement that a tube amplifies a signal is often puzzling to beginners. Old-timers have heard and thought of it so often that they have just accepted amplification as a fact.

What does an ordinary dictionary say about the word "amplify"? It says, among other things, that to amplify is to enlarge or to expand. That's where the trouble comes in. A signal is just a varying voltage. How can we make a voltage larger or how can it be expanded? The answer is, that this cannot be done? A tube does not take a signal and stretch it in some mysterious way. With a tube we actually make a new signal larger than the original. The original signal is used only as a pattern. Since the new signal is an enlarged duplicate of the original it is the commonly accepted practice to say the original signal has been amplified. Actually it is all right to say and even eventually think this as long as you have a clear idea of the real operation of a tube.

Let's see how we can make a big signal, using a little one as a pattern. Amplification can be explained in terms of resistance, current, and voltage that are no more difficult to understand than Ohm's Law. To understand this we will have to explore a few simple circuits, but you will find this well worthwhile.

A simple battery and resistor circuit is shown in Fig. 1. It consists of a 90-volt battery we have marked B for purposes of identification, a resistor marked R, connecting wires and a voltmeter. The full B

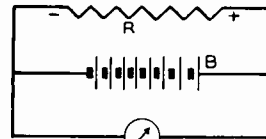

Fig. 1.

battery voltage of 90 volts is applied across R, causing current to flow.

Now for purposes of our story only, let's suppose we can break resistor R exactly in half—so exactly in half that the resistance of each half will be equal. Now let's splice the two ends together with a piece of wire and put the unit back in the simple circuit as shown in Fig. 2A. Next let's re-draw the circuit slightly as shown in 2B. The two circuits are identical—we have just made a slight change in the physical position of the resistor symbols. Actually there is no difference, as far as current flow is concerned, between Fig. 2B and Fig. 1. The total resistance is the same and the 90-volt B supply is applied across the resistors.

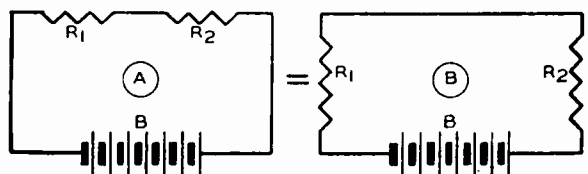

Fig. 2.

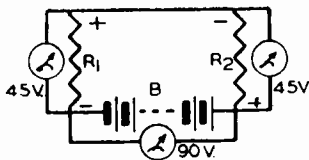

Fig. 3.

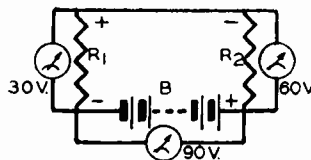

Fig. 4.

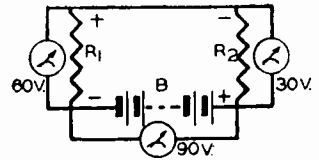

Fig. 5.

In Fig. 3 let's connect a voltmeter across the B battery which still reads 90 volts and which is the voltage across resistors R1 and R2. Next let's put voltmeters across R1 and R2. What will they read? Originally resistor R in Fig. 1 had 90 volts across it and this same voltage is across both R1 and R2. However, only half of the B supply voltage will appear across each resistor because each resistor is only half as large as R in Fig. 1. Consequently, each voltmeter reads 45 volts. This seems natural but there is a very important fact involved. This fact is that we have caused the source voltage to divide between R1 and R2.

In reading the meters in Fig. 3 note that the one across the source reads 90 volts. The readings on the other two meters have dropped to 45 volts each. For this reason we call the readings across R1 and R2 **VOLTAGE DROPS** to distinguish them from the source voltage. In other words, a voltage drop is just that part of the source voltage used in sending current through a part in a complete circuit. One other point of which you will be aware, if you have finished the fifth lesson in your course, is that in a complete circuit the voltage drops when added together always exactly equal the source voltage.

Now after this slight side trip let's get back to our circuit with the divided resistor.

If, instead of breaking the resistor in half, we broke it so that one was two-thirds of the original and the other one-third, we would have the condition shown in Fig. 4. Here R1 is one-third of R in Fig. 1 and R2 is two-thirds of R. This means that R2 is twice as large as R1. As you would expect, R2 has twice as much voltage drop across it as R1. This is shown by the voltmeters. Note that the voltages across R1 and R2 added together equal the source voltage.

The values of R1 and R2 have been reversed in Fig. 5 and there is now 60 volts across R1 and 30 volts across R2. A further point of interest is the polarity of the voltages across R1 and R2. These may be found with the meter test lead polarity, reversing the test leads if necessary to make the meters read upscale. However, it's easy to figure polarity if you know the direction of electron flow. Here is the rule which always holds true: *The end of a RESISTOR or PART at which electrons enter is always negative with respect to the end at which they leave.* Remem-

ber electrons flow out of the negative terminal of a *source*, through the circuit and back to the positive *source* terminal. This rule has led to the common misstatement that the current flowing through a part causes the voltage drop across it. Actually the current flow is the result of the voltage drop but since both always occur together it is all right to say the current produces the voltage drop as long as you really know what happens.

Now that we have taken our second side trip to straighten out your ideas, let's get back again to Fig. 5. You can see from Figs. 4 and 5 that the voltage will divide between the resistors in proportion to their resistance value. This means that if one of the resistors is twice the size of the other it will have twice as much voltage drop across it. If R1 in Fig. 5 is one-fifth the size of R2 there will be one-fifth of the source voltage across R1 and four-fifths of the source voltage across R2.

Going a step further, let's substitute a variable resistor for R1 as we have done in Fig. 6. As we vary the value of R1 the voltage across R2 will vary, going up and down as R1 changes in value. A signal voltage goes up and down as it varies in value. This means that if we could vary the resistance of R1 in the same manner as the signal voltage varies we would have a similar variation in voltage across R2. In other words, we would have manufactured or created a signal voltage across R2. Of course it's not possible to vary the value of R1 even ten times a second, corresponding to a 10-cycle audio signal, which is a very low frequency indeed. However, the principle is sound. All that we need is a device that varies in resistance in accordance with the variation in a signal voltage. Then we can make signals bigger than the original and use the original signal voltage as a pattern.

Let's see how this can be done with a tube. The most elementary tube is the diode, so named because it has two electrodes. These are the *plate* which, when made positive, attracts electrons from the cathode. Electrons will flow from one to the other without any physical connection because the tube is evacuated. The cathode is made of materials rich in free electrons. When heat is applied to the cathode (by means of an electrically heated wire, called a filament, and encircled by the cathode) the electrons in the cathode material speed up in their movements

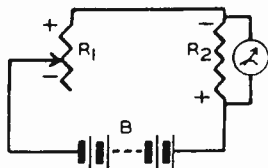

Fig. 6.

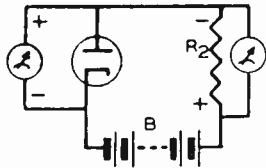

Fig. 7.

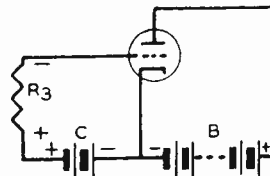

Fig. 8.

around their atoms. If enough heat is furnished electrons will leap right out of the cathode and into the vacuum. We could say that they have been boiled out. These electrons are attracted to the positively charged plate and stream across to it. The electrons lost by the cathode are replaced by those arriving from the negative side of the cathode to plate voltage supply.

By increasing the voltage, more electrons will flow to the plate. If the voltage is reduced the current flow decreases. In other words, the cathode-plate path in the tube has resistance and acts much like a resistor. As a matter of fact we can replace resistor R1 in Fig. 5 with a diode tube and the B supply voltage will divide between the tube and R2 as shown in Fig. 7. The cathode is negative with respect to the plate because electrons enter the cathode (from B-) and leave the plate. We have now replaced the fixed resistor in our voltage divider system with a diode tube.

It only remains to get some means of varying the resistance of the cathode-plate path in the tube and we can then make signal voltages appear across R2.

**The Grid.** The addition of another electrode in the tube called a grid makes it possible to use signal voltages to vary the cathode-to-plate resistance. We now have three electrodes in the tube—the cathode, the plate and the grid. This tube is called a triode, because it contains three electrodes.

Let us see what the grid can accomplish. First we will connect a low dc voltage source between the grid and cathode, omitting the larger supply voltage to the plate as shown in Fig. 8. The battery in the grid circuit is marked C to distinguish

it from B battery. The grid consists of parallel spaced wires, somewhat as shown in Fig. 8, all electrically connected together.

To show what happens, the grid by itself is illustrated in Fig. 9. Being quite close to the cathode the small positive charge on the grid has more pulling power on the electrons than does the higher plate voltage in Fig. 7. The electrons rush toward the grid. A very small percentage score a direct hit and land on the grid wires. By far the greatest number miss their mark so to speak, and pass right through the grid wires. The grid promptly attracts them back and since their speed has not had time to build up they finally land on the grid. All electrons which land on the grid wires flow through R3 and back to +C. The C supply voltage divides between R3 and the cathode-grid path in the tube.

Now we will reverse the connections to the C battery as shown in Fig. 10. This makes the grid negative with respect to the cathode and no electrons are forced through the tube and R3 by the C battery. Since there is no electron flow through R3 and through the tube there is no *voltage drop* across R3 and no voltage drop across R3. *All of the C voltage* is applied across the grid and the cathode, making the grid negative with respect to the cathode.

Fig. 11 shows what happens in the tube. The electrons have enough speed when they leave the cathode to travel an appreciable distance from the cathode. They are repelled by the negative charge on the grid and none can land on it. The electrons traveling in a path which would normally pass between the grid wires are also turned back.

With the grid still negative let's connect up the

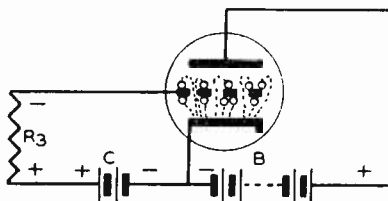

Fig. 9.

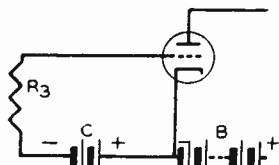

Fig. 10.

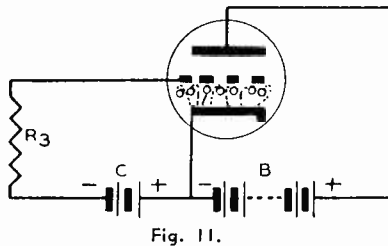

Fig. 11.

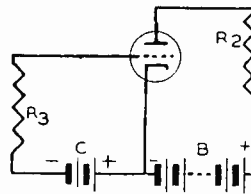

Fig. 12.

plate circuit as shown in Fig. 12. The grid still has a repelling effect on the electrons, turning many back to the cathode. However, the attractive force from the plate acts through the spaces between the grid wires and some electrons are drawn over to the plate. The action of the grid is shown in Fig. 13. If the grid is made more negative with respect to the cathode, fewer electrons reach the plate and if the grid is made sufficiently negative no electrons can pass and we say the plate current is cut off. Thus, varying the grid-to-cathode voltage varies the cathode-to-plate resistance in the tube and consequently the voltage drop across R2. The grid is usually kept at a negative potential so it will not steal electrons that would ordinarily reach the plate.

If we apply a signal voltage, say from a microphone, across grid resistor R3 in Fig. 14, the microphone voltage will alternately add to and subtract from the C battery voltage. Thus the grid-to-cathode voltage will become alternately more negative and less negative. When the grid is more negative the tube resistance goes up and the voltage drop across R2 decreases. When the grid is made less negative the tube resistance decreases and the drop across R2 increases. By dividing the B supply in this manner between the tube and R2 we make a signal voltage appear across R2. Since the signal across R2 is greater than that across R3 we say that the signal has been amplified.

Because the grid is so much closer to the cathode than the plate it has, volt for volt, more effect on the passage of electrons through the tube than the plate voltage. As a matter of fact, a voltage change of 1 volt on the grid may cause

a voltage change of 12 volts across R2. In this case we would say that the amplification or gain of the stage is 12 times. With some tubes a stage gain of over 100 times may be readily obtained.

Before closing this article there are one or two more points about amplifier tube circuits which can be cleared up. Often letters are received asking why the electrons from the negative terminal of the B battery are not attracted to the positive terminal of the C battery. Remember that if electrons enter the positive terminal of a battery an equal number must leave the negative terminal. The C battery connects to an open circuit and electrons cannot get off the grid and go to the plate. For this reason no electrons flow from B- to C+. The electrons from B- all go to the cathode, across to the plate, through R2 and back to B+.

Let's go back to fundamentals again and see how the C battery can be eliminated. In Fig. 15 we have three resistors across the B battery, R1 corresponding to the plate-cathode path in the tube, R2 to the plate resistor, and a small resistor marked R. The polarity of the voltage drops indicated by the meters is shown. Note carefully that point 1 is negative with respect to points 2, 3 and 4. Point 2 is negative with respect to points 3 and 4 but is positive as far as point 1 is concerned.

Now let's replace R1 with the cathode-plate of a triode tube as shown in Fig. 16. Again point 1 is negative with respect to points 2, 3 and 4. However, grid resistor R3 connects to point 1 and since no electrons flow from the cathode to the grid none flow through resistor R3. There-

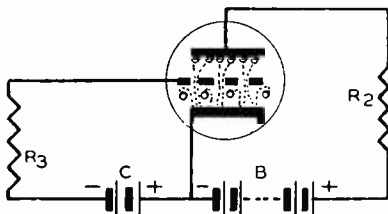

Fig. 13.

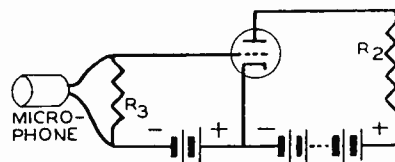

Fig. 14.

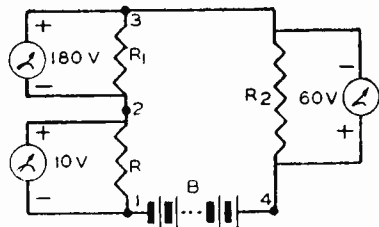

Fig. 15.

fore the grid is at the same potential as point 1 and is also negative with respect to point 2 (the cathode). For this reason there is no need to use a C battery to make the grid negative with respect to the cathode. The voltage across R can be held constant, even though the voltage across the tube and across R2 varies, by connecting a condenser across R2. The way the condenser does this job, however, is not a part of this story.

When signals are applied to R3 by the microphone electrons do flow through R3 but not through the cathode-grid path. The microphone

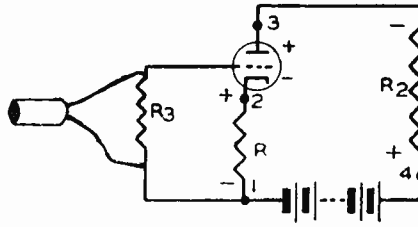

Fig. 16.

voltage across R3 adds to and subtracts from the steady grid cathode voltage, varies the tube resistance and hence the voltage division between the tube and R2.

This is not the complete story of tubes by any means but here's hoping it clears some things up for you and makes more advanced ideas easier to grasp. Vacuum tube circuits and their functions are often easier to understand if you reduce them to their simple equivalent circuits as we have done here.

— n r i —

— n r i —

## Pure-Picture Color TV Monitor Introduced

A "pure-picture" 21-inch television monitor which promises unprecedented quality-control of color programming in broadcast and closed-circuit operations was announced by the Broadcast and TV Equipment Department of the Radio Corporation of America.

The monitor is described (TM-21) as a major engineering development which provides broadcasters with a new high standard for testing and evaluating the performance of station color studio and transmitting equipment. The TM-21, now in production, is priced at \$3,650.

Engineered for the ultra-high quality, stability, and uniformity required in color-broadcast and closed-circuit operations, the 21-inch monitor reproduces faithfully all information contained in a compatible color picture. It presents the scene exactly as the camera sees it, and facilitates pinpointing elements of the overall TV system which may need adjustment.

As a reference standard for evaluating the color-fidelity of the complete TV broadcast system, the TM-21 monitor provides precision checks of color registration, color balance, shading, deflection and transmission system transients, effects of pedestal adjustments, as well as camera deflection linearity, chrome level, and phase or hue adjustments.

This RCA development, it is said, represents the best available standard against which color performance can be evaluated. In addition to improving the quality of color programming and increasing the operating economy and efficiency of station equipment, the monitor serves as an excellent medium for presenting programs for analysis by clients and program staffs.

The monitor may be used for monitoring color-picture quality of color-camera chains, switching systems, master control, and transmitting control.

Its technical advances include: feedback stabilization throughout; kinescope protection from loss of horizontal deflection or video overdrive, and regulated voltages for stability. Other features are: automatic wide-band operation during monochrome picture intervals; automatic brightness tracking for color balance, and non-interacting convergence circuits.

Designed for ultra-simple initial adjustment, without the aid of an oscilloscope, the monitor provides a built-in test switch which reduces set-up time to minutes, and a screen-grid selector switch for quick viewing of primary colors. Once set, monitor adjustments remain fixed over long time periods.

# RCA PRODUCES ITS TWO BILLIONTH ELECTRON TUBE

The Radio Corporation of America's two billionth electron tube came off an assembly line at the company's Harrison, N. J. plant, it was recently announced by President John L. Burns.

It was an RCA traveling-wave tube designed for use in classified electronic equipment for the Armed Forces. The tube was shipped to RCA's West Coast Defense Electronic Products plant at Los Angeles where it will form the "heart" of a new defensive system being built for the U. S. Navy.

Mr. Burns said that in twenty-eight years of tube making, RCA has produced enough entertainment-type receiving tubes and picture tubes to equip 17½ million TV sets and 300 million radios. The rest of the two billion total consisted of various special receiving-type industrial tubes, power tubes, and tubes for television cameras, oscilloscopes and microwave equipment.

"The Radio Corporation of America is proud to be the first electronic company in the world to manufacture two billion tubes," Mr. Burns said. "The electron tube is a basic component of all the equipment upon which our industry has grown. Through its ability to generate, detect and strengthen electrical signals, the tube makes possible virtually every form of modern communications and home entertainment, as well as the complex electronic systems for business, industry and defense. It is significant that about 25 per cent of the tube industry's sales volume is accounted for by defense operations. Notable progress has been made over the years in extending tube applications, and it is reasonable to expect even wider uses for tubes in areas awaiting research and development in the Space Age."

Besides Mr. Burns, other RCA executives who watched as Roman Wasilewski of Lyndhurst, N. J., took optical pyrometer readings on the traveling-wave tube were W. W. Watts, Executive Vice President, Electronic Components, and D. Y. Smith, Vice President and General Manager, Electron Tube Division. The tube, complete with focusing magnet, measures 14½ inches in length, 1½ inches in diameter and weighs a pound and a half. When in operation, it produces a beam of electrons which interacts with a guided electromagnetic wave to produce ampli-

fication of signals at ultra-high frequencies. Various types of these tubes have brought about new techniques for ground and airborne radar, height finders, missile control systems, microwave communications equipment and for counter-measures equipment.

Mr. Smith explained that the RCA Electron Tube Division buys goods and services from some 3,000 suppliers, the majority of whom are comparatively small businesses.

"In manufacturing the 17½ million television picture tubes made to date," he pointed out, "we required more than 150,000 tons of glass which went into the formation of the envelopes. We also used thousands of tons of stainless steel; 1,500 miles of tungsten wire; and 14,000 miles of nickel and copper wire.

"In 1919, when RCA was formed, most tubes were manufactured by electric lamp companies because they had the necessary exhaust facilities and techniques. During its early years, RCA served as a sales agent for other firms making radio tubes. Then, in 1930, the company acquired its own manufacturing facilities.

"A total of 17 million tubes was manufactured by the company in 1934. As the demand for radio receivers increased, tube production began to soar. In 1934 the tube industry manufactured 63 million units and seven years later the total jumped to 136 million. The spectacular popularity of television after 1946 was largely responsible for another important record achieved by the company on June 7, 1949, when RCA's one-millionth TV picture tube was produced. During 1958, the tube industry expects to manufacture about 500 million units. For nearly two decades, the bulk of RCA's tube production was in home entertainment types. With the increasing use of electronic equipment by commercial and industrial firms, RCA has expanded its line of tubes to provide the necessary types for the new equipment. Today, the Electron Tube Division markets more than 800 different types, ranging in price from less than 50 cents to over \$20,000."

Electron tubes are made at RCA plants in Harrison and Woodbridge, N. J., Cincinnati, Ohio, Lancaster, Penna., and Marion and Indianapolis, Ind.

— n r i —

— n r i —

*Marcus Aurelius: "Let not your mind run on what you lack as much as on what you have. Of the things you have, select the best; and then reflect how eagerly they would have been sought if you did not have them."*





# NRI. ALUMNI NEWS

Howard Smith	President
F. Earl Oliver	Vice Pres
Jules Cohen	Vice Pres
William Fox	Vice Pres
Joseph Stocker	Vice Pres
Theodore E. Rose	Executive Secretary

## Chapter Chatter

**Los Angeles Chapter's** Chairman **Joseph Stocker** at a recent meeting brought in his NRI Television receiver and a scope for demonstration purposes. Participating in the demonstration, **Joe Stocker, Tom McMullen** and **Maurice Lerner** went through the video I-F, Video AMP, horizontal and vertical sweep circuits to show the members present the correct scope patterns. This was an interesting demonstration, one of real practical value.

Although the Chapter was established only last fall, it has made good progress in getting organized and the members have become acquainted with each other to the point where they have developed the necessary collective spirit. The members are constantly improving the programs for conducting meetings to the best advantage of the membership.

Here is an opportunity for NRI students and graduates in the area to join a new and growing



A meeting of the Los Angeles Chapter. The officers seated at the table are, left to right: Thomas McMullen, Secretary; Joseph Stocker, Chairman; and Clarence Adams, Treasurer.

Local Chapter of the NRI Alumni Association. All students and graduates will be welcome. The meetings are held at 8 P.M. on the second Friday of each month at St. Joseph's Catholic School Hall, 1220 S. Los Angeles St. For further information get in touch with Chairman **Joseph Stocker**, 208 E. Pico Blvd., Los Angeles.

**New Orleans Chapter**, as reported in the last issue of National Radio-TV News, is featuring a series of lectures by Mr. **Milton Kennedy**, recently an instructor in electronics for the U. S. Army. Mr. Kennedy informed the members that he is well acquainted with NRI, has known about it for years. He has been associated with electronics since 1942. He is thoroughly grounded in theory but emphasizes the practical side of Radio-TV Servicing.

In his first lecture of the series Mr. Kennedy asked members whether they would like general discussions of TV trouble-shooting methods. The members indicated that they were definitely in favor of this and Mr. Kennedy has proceeded along these lines. The lectures are interspersed with question-and-answer discussions between members and Mr. Kennedy, which add much to highlight the points brought up by Mr. Kennedy. He feels that it is important to discuss service problems raised by the members themselves, so that in this way he can give practical help to the individual members. Mr. Kennedy also stressed the importance of the Radio-TV serviceman continuing to study, not only in order to keep up to date with advances and developments but also because the Radio-TV serviceman can't learn too much about his subject.

Mr. Kennedy looks at Radio-TV service problems from the serviceman's point of view, and talks in the serviceman's language in discussing them. Because of his thorough grasp of theory, his long experience and his emphasis on the practical aspects of Radio-TV Servicing, Mr. Kennedy's lectures are proving to be extremely valuable and helpful to the members of the

Chapter.

All NRI students and graduates in the New Orleans area are cordially invited to attend these lectures and will be missing an unusual opportunity if they do not do so.

The officers elected to serve the Chapter for the current year are **Patrick Boudreaux**, Chairman; **Walter Berrigan**, Vice-Chairman; **Louis Grossman**, Secretary; and **Octave Jumonville**, Treasurer.

Meetings are held at 8 P.M. on the second Tuesday of each month at the home of Secretary **Louis Grossman**, 2229 Napoleon Avenue. For more information about the meetings get in touch either with the Secretary or with Chairman **Patrick Boudreaux**, 1015 Race Street, New Orleans.

**Southeastern Massachusetts Chapter** reports its slate of officers to serve during 1958 as follows: **Michael Lesiak**, Chairman; **Walter Adamiec**, Vice-Chairman; **Ernest McKay**, Secretary; **William Wade, Jr.**, Treasurer; **John Pritchard** and **Arthur Hubert**, Financial Committee.

Vice-Chairman **Walter Adamiec** brought in an early NRI Television receiver to use for a demonstration during which stagger-tuned alignment was discussed. This same TV receiver will be the subject of various other discussions and demonstrations at future meetings, for which Vice-Chairman **Walter Adamiec** was designated as Program Chairman.

The Chapter meets on the first Monday of each month in the DAV Hall in Fall River, at 8 P.M. NRI students and graduates in the area are welcome to attend the meetings either as guests or prospective members. Get in touch with Chairman **Michael Lesiak**, 20 Cooper Street, Taunton, or Secretary **Ernest McKay**, 16 Austin Court, New Bedford.

**Detroit Chapter** mourns the passing of one of its oldest and most loyal members, **Max Ludke**, who was fatally injured in an automobile accident. Max will be sorely missed.

The Chapter has informed National Headquarters that the officers elected to serve for 1958 are: **John Nagy**, Chairman; **James Kelley**, Vice-Chairman; **Ellsworth Umbreit**, Recording Secretary; **Milton Oliver**, Assistant Secretary; **Earl Oliver**, Treasurer; **John Stanish** and **Asa Belton**, Financial Committee. **Charles Mills**, Sergeant-At-Arms; and **Prince Bray**, Librarian.

Vice-Chairman **James Kelley** has been giving a series of talks and demonstrations on transistor theory and practice, using a 10-circuit transistor lab kit which he purchased. These talks were excellent and were much appreciated

by the members.

Treasurer **Earl Oliver** and Secretary **Ellsworth Umbreit** have agreed to undertake a series of talks and demonstrations on troubleshooting TV receivers, stage by stage, using a one-circuit panel board that can be attached to a TV receiver so that components can be quickly changed. These talks and demonstrations should prove interesting and valuable.

A committee has already been named to make plans for the Twenty-Fifth Detroit Chapter Anniversary Party to be held in October. The committee consists of **Charles Mills**, Chairman, **Earl Oliver**, and **John Stanish**.

All NRI students and graduates in the Detroit area are cordially invited to attend the Chapter's meetings. The chapter meets on the second and fourth Friday of each month, 8 P.M., at St. Andrews Hall, 431 East Congress Street, Detroit. For more information contact Chairman **John Nagy**, 1406 Euclid, Lincoln Park, or Secretary **Ellsworth Umbreit**, 12523 Racine Ave., Detroit.

**Milwaukee Chapter** recently admitted Graduate **Ralph Lassen** of Milwaukee to membership and he was given a cordial welcome.

**Mr. Lassen** entered into the spirit of the Chapter right away and began contributing to its meetings immediately. He, together with Vice-Chairman **Slavko Petrich**, led an open discussion on TV prices and charges to customers, and in general, how to handle customers. This is, of course, a large subject and an important one—one that all Radio-TV servicemen would do well to learn all they can about.

At another meeting **Mr. Lassen** raised the question of the relationship between electron flow



Officers of the Milwaukee Chapter. Left to right: Augusto Piechowski, Sergeant-at-arms; Philip Rinke, Chairman; Louis Spomer, Treasurer; Erwin Kapheim, Secretary; Slavko Petrich, Vice-Chairman.

versus current flow in a TV receiver. In the general discussion which followed, Vice-Chairman **Slavko Petrich** gave an enlightening black-board demonstration of the current flow and



Past Chairman (now Secretary) Erwin Kapheim of the Milwaukee Chapter addressing a meeting of the Chapter.

electron flow in a TV circuit. Bringing up problems of this kind for solution at meetings is one of the most valuable advantages of membership in a local chapter of the NRI Alumni Association.

The Milwaukee Chapter will welcome all NRI students and graduates in its area to its meetings. The Chapter meets on the third Monday of each month at the Radio-TV Store and Shop of **S. J. Petrich**, 5901 W. Vliet St., Milwaukee. The Chairman is **Phillip Rinke**, RFD 3, Box 356, Pewaukee. The Secretary is **Erwin Kapheim**, 3525 N. Fourth Street, Milwaukee.

**New York City Chapter** has been pleased to welcome the many new members admitted to membership at the past few meetings. Students and graduates come for a visit, see what is going on, and stay to become a member. This is proof that the meetings are of value—are interesting and informative. The Chapter's own members deliver lectures and demonstrations so well that there is never a dull moment at any of the meetings.

Among recent speakers were **John Maxwell** who, upon a return from the "sunny south" gave a brief outline of how Radio and TV shops operate in Florida. **Tom Hull**, with the assistance of **Edward Chin** and **John Maxwell**, worked on the Chapter's new TV set. Acting on suggestions from the floor, they restored both the picture and sound. **James Eaddy** told of his experiences with a bad picture tube and explained how to use a 5-inch test tube for best results.

Attendance at one meeting suffered as a result of illness among the members, but **James Eaddy** and **Frank Catalano** stepped in and got things

going. **Jim**, with some very able assistance from the floor, corrected the picture trouble on a TV set, then **Frank** replaced an IF transformer in the sound track, which corrected the sound trouble.

The first meeting in February was devoted primarily to horizontal oscillator circuits. **Tom Hull** gave a lecture on the subject and answered questions from the floor. **Cres Gomez**, the Chapter's distinguished member who was recently nominated for a National Public Service Award, related some of his experiences with this circuit.

To add a touch of humor, **Secretary Dave Spitzer** came up with something new. A copy of the first edition of the "Funny Bone," a leaflet of jokes and wit, was offered to each member and guest present. It looks like the idea caught on and put the fellows in a friendlier and happier frame of mind. More editions of the "Funny Bone" are planned.

Out-of-town NRI men visiting in New York are cordially invited to attend a meeting as guests. The Chapter also urges students and graduates in the area to come in and get acquainted. Meetings are held on the first and third Thursday of each month at 12 St. Marks Place, New York City. Contact **Chairman Edward McAdams**, 3430 Irwin Ave., New York City or **Secretary Dave Spitzer**, 2052 81st St., Brooklyn, New York.

**Philadelphia-Camden Chapter** reports the admission of still more new members: Graduate **Nelson Taylor**, Philadelphia; Student **W. E. Gallagher**, Lansdowne, Pa.; Student **Larry McNulty**, Levittown, Pa. A hearty welcome to these new members!

As far as chapter programs and activities are concerned, the biggest news from the Philadelphia-Camden Chapter is that they have obtained the plans for a TV Dynamic Board from **Lyman Brown**, Technical Director of the Springfield, Mass., Chapter and have assigned a four-man committee to lay the ground work for the Board—work out the chassis, layout, components, and undertake whatever else is necessary for the assembly of the board. Chapter members are chipping in to defray the expense of constructing the board and they are all anxious to get ahead with it. Although construction of such a TV Dynamic Board will require a lot of time and work, it should prove to be one of the most rewarding projects undertaken by the Chapter.

In the meantime Chapter Member **Harvey Morris** is continuing his excellent lectures on alignment procedures. The members are enthusiastic about Harvey's talks, and well they should be, for they can learn a great deal from Harvey.

The Chapter makes a feature of having repre-

representatives of local Radio-TV distributors as guest speakers at its meetings. Secretary **Jules Cohen** has been very successful in getting these speakers. Due to recent changes in the distributorships in the Philadelphia-Camden area, it has lately been difficult to arrange for these speakers at the meetings. But Secretary **Jules Cohen** can be depended upon to handle this problem so that the Chapter can enjoy the advantages of having these speakers at its meetings.

NRI students and graduates in the Philadelphia-Camden area who are not members of the Chapter are nevertheless cordially invited to attend meetings either as guests or prospective members. Meetings are held at 8 P.M. on the second and fourth Monday of each month at the Knights of Columbus Hall, Tulip and Tyson Streets, Philadelphia. For more information write or telephone Secretary **Jules Cohen**, 7124 Souder Street, Philadelphia.

**Pittsburgh Chapter** reports its officers for the current year as follows: **Frank Skolnik**, Chairman; **William Lundy**, Vice-Chairman; **Kenneth Shipley**, Secretary; **Earl Uhl**, Treasurer; **Larry Steyer**, **Sylvester Steyer**, and **William Roberts**, Executive Committee.

The Chapter has for sometime been considering the construction of a dynamic demonstrator. Much thought and discussion has taken place as

to whether this should be a radio or a TV dynamic demonstrator. Chairman **Frank Skolnik** led the discussion in favor of a radio dynamic demonstrator. The decision was finally taken to build a radio dynamic demonstrator first, then later on consider the possibility of undertaking a TV dynamic demonstrator.

At the same meeting Secretary **Kenneth Shipley** gave a short but enlightening talk on spurious harmonics.

The major part of the subsequent meeting was devoted to beginning the actual construction of a dynamic radio demonstrator. Messrs. **Lundy**, **Schnader** and **Svidre** were the guiding lights of the endeavor, with several other members contributing their assistance as needed.

The Pittsburgh Chapter meets at 8 P.M. on the first Thursday of each month at 134 Market Place, Pittsburgh. All NRI students and graduates in the area are cordially invited to attend the meetings. For more information write or telephone Chairman **Frank Skolnik**, 932 Spring Garden Ave., Pittsburgh.

**Hagerstown (Cumberland Valley) Chapter** held a social at the home of Chapter Member **Reginald Ankeney** in Clear Spring, Maryland. This was a stag party—good beer—good food—and plenty of both. Everyone had a very enjoyable time.



Officers of the Pittsburgh Chapter for 1958. Seated left to right: Frank Skolnik, William Lundy, Kenneth Shipley, Earl Uhl. Standing: William Roberts, Larry Steyer, Sylvester Steyer.

All of last year's officers were re-elected to serve for the current year: **John Pearl**, Chairman; **Harry Straub**, Vice-Chairman; **Edwin Kemp**, Secretary; and **Robert Saum**, Treasurer.

At one meeting Chairman **John Pearl**, who is a teacher of electronics at the North Hagerstown High School, spoke on electron tubes. Another meeting was devoted to a general discussion of new electronic developments and similar topics of interest to members.

The Chapter is considering ways and means of holding a Hi-Fi demonstration at one of its forthcoming meetings. Such a demonstration should prove very interesting to the members.

NRI students in the Cumberland Valley will be welcomed as guests at the meetings. All those interested in doing so should contact Secretary **Edwin Kemp**, 618 Sunset Ave., Hagerstown, Md.

**Flint (Saginaw Valley) Chapter** reports that the officers elected to serve for 1958 are: **William Neuman**, Chairman; **Aaron Triplett**, Vice-Chairman; **George Hinman**, Secretary; and **Clyde Morrisett**, Treasurer. Warmest congratulations to these new officers.

A meeting was held at Vice-Chairman **Aaron Triplett's** repair shop. Using his equipment and a set he was servicing, a scope demonstration was given. Past-Chairman **Warren Willimson** explained the scope hook-up, traced the signal from antenna to the video detector, and explained stage gain and difference in wave shape. This demonstration was so well received by the members present that more such instructional meetings are planned for the future.

The Chapter is also considering the purchase of a complete Radio-TV Test Panel.

The Chapter extends a cordial invitation to all NRI students and graduates in the Saginaw Valley area to attend meetings as guests or prospective members. The Chapter meets at 7:30 PM at Vice-Chairman's **Aaron Triplett's** Radio-TV Shop, 2538 Wolcott, Flint. For further in-



Augusto Lorenzatti, Harold Broughton and Chairman Rupert McClellan tackling a TV set at Springfield Chapter's special meeting.

formation contact Vice-Chairman **Aaron Triplett** or Chairman **William Neuman**, 1613 Kiesel, Bay City.

**Springfield (Mass.) Chapter Chairman Rupert McClellan**, when he took office and outlined his plans for meetings, indicated that his most important plan called for an occasional special meeting to be held on a Saturday night at the shop of either **Technical Advisor Lyman Brown** or **Secretary Howard Smith**. The purpose of this plan is to give those members who work night-shifts in factories an opportunity to attend a meeting, since their work prevents them from being present at the regular Friday night meetings.

In line with **Chairman McClellan's** plan, the first such special meeting was held at the shop of **Technical Advisor Lyman Brown**. At this meeting, two TV sets were repaired by those attending. The second one was a real dog and was not completed but enough so that all members present grasped the idea of how to finish it. The attending members were so pleased with the results of this trial meeting that the Chapter is going to hold more such special meetings.

NRI students and graduates in the Springfield area are cordially invited to attend not only these special meetings but also the regular

meetings. The regular meetings are held at 7:00 P.M. on the first and third Friday of each month at U. S. Army Headquarters Building, 50 East

St., Springfield. For further information contact Secretary Howard Smith, 53 Bangor St., Springfield, Mass.

— n r i —

— n r i —

# Promptness Makes More and Better Friends

By

DR. JAMES F. BENDER, DIRECTOR

THE NATIONAL INSTITUTE FOR HUMAN RELATIONS

*copyrighted, all rights reserved*

THEY began to call him "the late Mr. Jones" while he was still in his twenties. You see, he was seldom on time for an appointment. The poor fellow lived breathlessly, rushing around, missing the boat, and with more apologies on his tongue than a goose has feathers.

Strangers might have guessed, "There goes a busy fellow." But in truth, he was about as busy as an eight-day clock lacking a main spring. All his huffing and puffing didn't add up to promptness. For time had made him a slave—kept him sweating on a treadmill.

And that was the reason why Jones' human relations missed fire: *He never got in the habit of being prompt.* He never learned how to turn the tables—to make time a slave.

This business of being prompt—whether at home or on the job—is a corner-stone of good human relations. Go down a list of men and women you like best, and arrange them according to their promptness. Nine time out of ten, the leading lady (or man) is the one who never keeps you waiting.

And so, if you would build better human relations, get in the habit of being prompt. Like a miser, budget your hours and minutes, particularly those that involve friends, relatives, and co-workers. And as the habit grows, your credit

rating, your popularity, and your workmanship—all climb heavenward.

Have you ever noticed that people who are prompt have an air of strength and composure about them? They're not easily thrown off base. They know there is time enough. Down deep within them they have developed a sense of keeping in step with time. They have discovered a rhythm in life.

When you discover this rhythm, people shower you with increased responsibilities, and these have rewards in tow. And the secret of being prompt is not hard to find. All we have to do is say to ourselves "From now on, I'm going to be prompt." Keeping that promise faithfully for two or three weeks, in all our family and outside relationships, ordinarily wears a groove into which our schedules fit nicely. The groove may need a bit of lubrication from time to time, and this is easily supplied with a renewal of the promise. It really isn't difficult at all.

More than two centuries ago a father wrote to his son at college these priceless words of advice—jewels of wisdom for those who wish to improve their human relations—"Know the value of promptness: and snatch, seize and enjoy every moment of time. No idleness, no laziness, no procrastination: never put off till tomorrow what you can do today."

## INDEX

Article	Page
Editorial .....	2
Adding Short Wave Reception to the 5-Tube 7W Receiver .....	3
How Amplification Is Obtained With A Transistor .....	9
How to Build a Low-Cost, Hi-Fi Amplifier	11
NRI Professional Tube Tester and Signal Generator .....	17
A New Slant on Vacuum Tube Amplifiers .....	19
NRI Alumni News, Chapter Chatter .....	25
Here and There Among Alumni Members	31

## COVER PHOTO

Our sincere thanks to Graduate Lewis M. D. Grainger for sending along this excellent photo of his well-organized, neat, service shop. Mr. Grainger writes:

"I have operated a full time business of my own for the past year, and have been a Philco dealer during that time. I have built up a worthwhile and profitable business through your training. When I go into a home to service Radio or a TV receiver and let it be known I am an NRI graduate, the customers are always put at ease, and show every indication that they have complete confidence in my ability to service their set in an intelligent manner, receive prompt efficient service and fair treatment. I also find that by acquiring the needed up to date testing equipment through the school and at the worthwhile saving realized, I can service the set with promptness, and efficiency which pleases the customer and saves me money."

Lewis M. D. Grainger  
Route #1  
Glenn-Allen, Va.

— n r i —

## STEREO TAPES

Stereo tapes are coming up fast in the hi-fidelity field. In 1957, stereo recorders accounted for one-half of the national recorder sales. 75% of all recorded tapes sold to customers were stereo. Stereo tapes are expected to hit 90% of the tape market this year. By 1960, it is predicted 3,000,000 tape recorders will be in use in the U.S. These estimates are by the Magnetic Recording Industry Association.

# HERE AND THERE AMONG ALUMNI MEMBERS

Graduate John J. Kondrach, Newark, N. J. reports he is now a Field Service Engineer for the Weston Electrical Instrument Corp. He finds the work extremely interesting and credits his NRI training for giving him his start. Best wishes for continued success, John!

James R. Jacobs recently accepted a position as full time salesman for the Specialty Distributing Co., wholesale Radio and TV receivers, located in Chattanooga, Tennessee. Before making his move, he was a TV technician in Shelbyville, Tenn. Knowing the technical aspects thoroughly of each items he sells is undoubtedly a "must."

Sgt. Robert W. Eskew writes his Radio Television Servicing course qualified him for micro-wave radio repair school at Ft. Monmouth, N. J. Graduated in the upper third of his class. Is now assistant chief at an east coast micro-wave relay station.

One of NRI's "old timers," 1924 Graduate Gregorio V. Bonilla sends us an excellent resume of his work in Communications during the past 33 odd years. Since 1926, he has been with RCA Communications Inc., located in Manila; now holds the title of Engineer in Charge for the receiving station there.

Robert Ciochi, San Luis Obispo, California, is now making plans to open his own part-time TV, hi-fi business. Says that his radio-TV hobby has developed into an extra curricular activity, both profitable and fun. His regular job is Radio Dispatcher Clerk with the California Highway Patrol.

Communications Graduate Robert B. Butler holds a first-class Radiotelephone ticket. This proved extremely helpful in obtaining a position with Philco as a TechRep field engineer. Mr. Butler makes his home in Syracuse, N. Y.

A Graduate of three NRI courses, John F. Piatt works at the Edwards Air Force base flight test center in aircraft instrumentation and telemetering. John spends his spare time installing FM hi-fi systems for his neighbors in the Lancaster, California area.

# NATIONAL RADIO-TV NEWS

3939 Wisconsin Ave., N.W.

Washington 16, D. C.

Second-class mail  
privileges authorized  
at Washington, D. C.

Mr Francis H Fingato  
1653 California St  
Denver 2 Colo

25236-G

4A