

NATIONAL RADIO NEWS

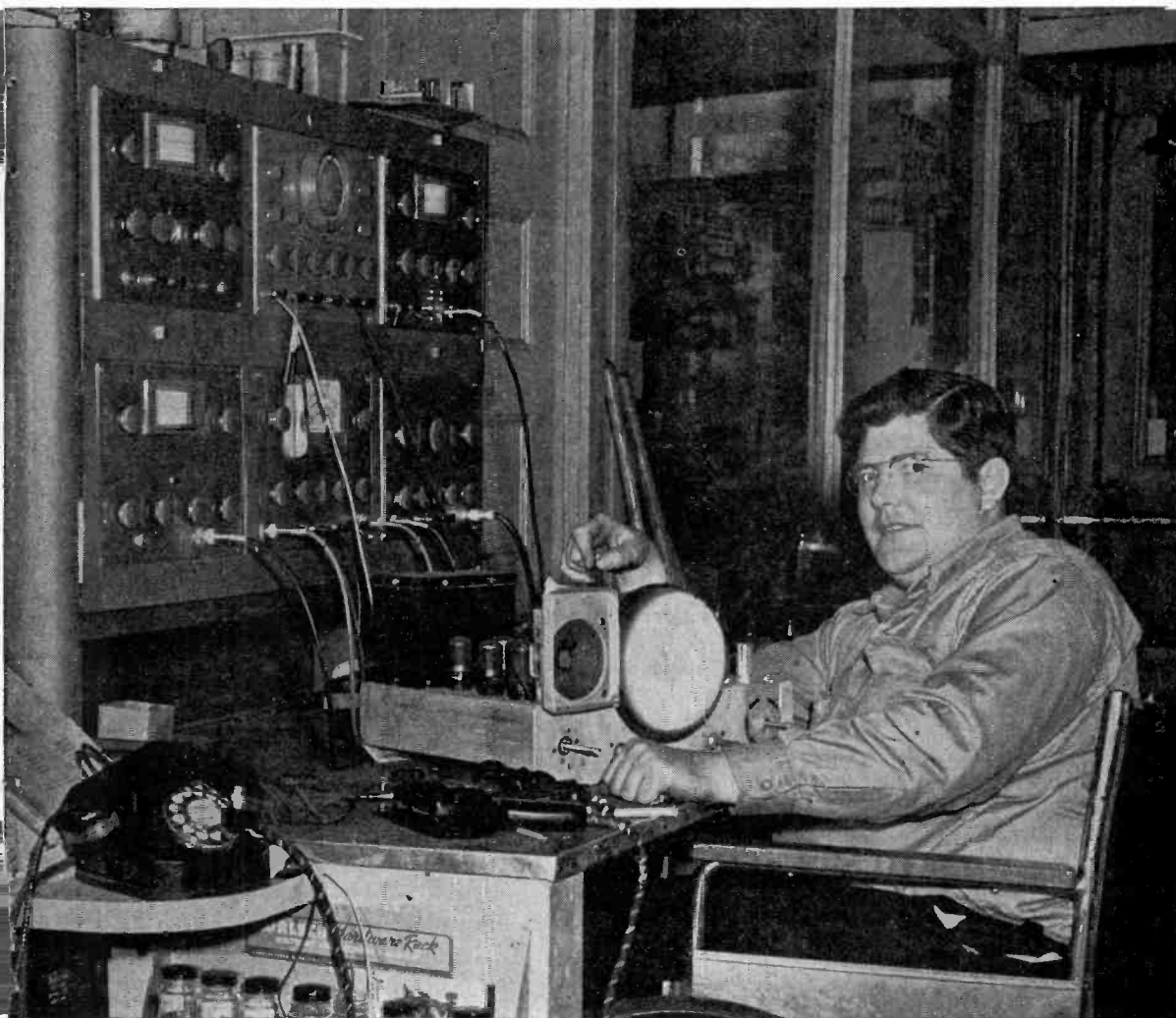

IN THIS ISSUE

Building a Small Public Address System

Interpretation of TV Test Patterns

Alumni Association News

Feb.-Mar.
1950

VOL. 14
No. 1



Doing Our Part

To increase *your* earning power was one of the reasons why you decided to enroll with NRI. You are willing to devote your spare time to the study of Radio and Television both because you like it, and because you know that increasing your knowledge can mean better living for you and your family, better education for your children, and a host of other desirable things. Thus, increasing your earning power benefits you *directly*.

But what of things which money cannot buy—*freedom, religious liberty, your right to open your business wherever and whenever you please—blessings which we enjoy as American Citizens. Will concentrating your efforts on accumulating security for yourself and your family help to preserve these precious things? I feel that it will, because a citizen who does not wish to be dominated by his government should be financially independent of his government. Thus, your self-sufficiency attained through acquiring technical training is a big step in helping to preserve American ideals, but is it enough?*

Being an American Citizen means owing your allegiance at all times to your country. Millions of us have learned the meaning of this in times of war, but, and perhaps more important, what can we contribute in times of peace? Because the United States has a government resting “on the people,” you and I, as ordinary fellows, must keep informed about the political trends of our government if we are to do our part in *safeguarding* and *improving* those principles which benefit *each* of us *every* day. This is quite a challenge. It calls for the expression of *your own* carefully formed opinions—at the polls, in your lodge or church, or in letters to your Congressmen. I hope that you will strive every day toward becoming a better citizen as well as a better technician.

J. E. Smith, President

BUILDING A SMALL PUBLIC ADDRESS SYSTEM

By LOUIS E. GARNER, JR.

NRI Consultant



Louis E. Garner, Jr.

A SMALL, inexpensive, and easily built public address system is shown in Fig. 1. Two speakers mounted in wall baffles, a small microphone, and a 15 watt amplifier comprise the complete system. A system this size can easily handle an audience up to about 2000 persons or an outdoor area coverage up to about 10,000 square feet (depending on outside noise levels).

The amplifier has provision not only for a microphone input but also for a phonograph and both can be used simultaneously with individual control of volume on either. Electronic mixing is used so there is no interaction between the microphone and phonograph gain controls. A simple, but effective, tone control circuit is incorporated permitting the operator to attenuate the "high's" when desired.

Advanced students, who are able to build equipment from a schematic diagram, and graduates should have little or no trouble in building this unit. However, the work should not be undertaken by beginning students or those not able to wire from a schematic diagram without detailed instructions. If you are a beginner, it is better to wait until you have progressed further with your course. As you study more advanced lessons, progress with your experimental work, and gain more experience, you will soon find yourself in a position where you can build an amplifier like this one.

This complete amplifier system may be used by the serviceman for work in a shop, to play music throughout a small store, or as a rental unit for lectures, small clubs, and meetings. When the service technician has a small P.A. system available, he can often pick up extra money by

renting it to other individuals or to clubs and business concerns.

This P.A. system can be built for a total cost of from \$60 to \$80, depending upon how many parts you have available in your "junk box," and the quality of the individual components employed. As an example, a microphone can be purchased which costs more than the complete amplifier system. Similarly, expensive loudspeakers can be used. However, for P.A. work, expensive high fidelity components are seldom employed.

Construction of an amplifier system of this type, unless the builder has a number of the parts already available, is likely to cost more than the purchase of a commercially built unit. In general, this is true whenever mass-produced electronic units are considered. Small receivers, amplifiers, and similar mass-produced units, can almost always be purchased cheaper than the total cost of the parts purchased individually.

Reduction in cost can be obtained by purchasing one of the excellent commercially available "kits" from which an amplifier can be built. Most large wholesale radio supply houses can furnish kits for building amplifiers (as well as other pieces of electronic equipment) in addition to furnishing the individual parts for the construction of the unit described herein.

Therefore, if cost is a factor, you should certainly purchase either a commercially available amplifier or a commercially available kit if you need a small P.A. system. On the other hand, if you like to build things yourself for the experience and for the fun, or if you have the major parts available, then you should certainly get a "kick"



Fig. 1.

out of building the amplifier described in this article.

The "heart" of a public address system is the amplifier. Although the complete system is shown in Figure 1, the amplifier alone, with its top cover removed, is shown in Figure 2. A bottom view of the amplifier, showing the wiring, is given in Figure 3. Finally, the complete schematic diagram is given in Figure 4.

Circuit Description

The microphone is connected across load resistor R_1 and the signal appearing here is amplified by the 6SJ7 pentode preamplifier. The amplified signal appearing across R_4 is fed through condenser C_4 to the microphone volume control R_6 .

At the same time, a signal from a phonograph pickup can be fed across R_7 , which acts as the phono gain control, to the grid of the second section of the 6SN7 dual triode mixer.

The microphone and phono signals are further amplified by the 6SN7 and the two signals combined in the plate circuit of this stage through isolating resistors R_9 and R_{10} . The resulting signal is fed to the grid of the final voltage amplifier through condenser C_5 . Condenser C_6 , in conjunction with variable resistor R_{16} , acts as a conventional "losser" type tone control.

The signal is amplified further by the first section of the 6SN7 and the amplified signal appears across R_{18} . This signal is coupled through condenser C_7 to the grid of one of the 6V6 push-pull

amplifiers. At the same time, part of this signal is fed back through C_8 and appears across variable resistor R_{17} . This resistor is used to adjust the input signal to the second section of the 6SN7 so that the signal appearing across R_{19} is equal to that appearing across R_{18} and the second 6V6 power amplifier tube will receive the same amount of signal drive as the first.

The two 6V6 tubes together act as a push-pull power amplifier and output transformer T_2 is used to match these two tubes to the loudspeakers.

Bias is provided for all three voltage amplifier tubes by means of cathode resistors. For the output stage, however, variable resistor R_{22} in the power supply is used to provide fixed bias.

Decoupling networks consisting of R_5 and C_{2A} , and R_{13} and C_{2B} are used to prevent interaction between stages. A conventional full-wave rectifier AC type power supply is provided. Filtering is accomplished by means of choke CH_1 and electrolytic filter condensers C_{11A} and C_{11B} . Condenser C_{12} is used across bias resistor R_{22} to by-pass any AC signals here.

This circuit has two features not generally found in inexpensive P.A. amplifier circuits. One is the use of electronic mixing for the mike and phono inputs. The other is the use of a variable control for adjusting the feed-back of the phase-inverter amplifier (R_{17}). The use of such an adjustment permits the drive to the push-pull amplifier to be balanced exactly.

Construction

The lay-out used for the amplifier shown in the illustrations is given in Figure 5. Dimensions are not given since these will vary depending upon the exact type of amplifier foundation or chassis used by the builder, and upon the exact sizes of the parts employed. Lay-out dimensions are not available from NRI, and the builder should make his own layout in accordance with standard practice. Generally speaking, layout is not critical in a public address amplifier. There are, however, certain general rules you should remember.

First, the output transformer should not be located near the input amplifier nor too near the power transformer. If located too close to the input, there may be over-all feedback, resulting in oscillation with certain settings of the gain control. If located too close to the power transformer, there may be a certain amount of hum induced in the transformer.

Grid and plate leads should be kept as short as is possible for the layout chosen. In no case should grid leads be run any distance across the chassis. The layout chosen should be such that the length of grid leads is little more than the size of the coupling condenser or part used for coupling. If necessary to run a signal lead or grid lead more than an inch or so, the lead should be shielded.

The length of screen grid leads, cathode leads, and B+ or filament leads, is not too important. However, filament leads should be kept away from grid terminals of the tubes and the arrangement of the wiring should be such that there is minimum coupling between filament leads and any grid leads.

In making your own layout, be sure to provide adequate spacing around the electrolytic filter condensers to insure sufficient ventilation so these condensers will not become unduly warm. Excessive heat will shorten an electrolytic condenser's life considerably.

The exact order of wiring is unimportant. It is best, however, to study each stage carefully to see if it is necessary to install parts in a special order. Occasionally, it is necessary to install one part over another in order to keep the leads short. Where such a step is necessary, a careful

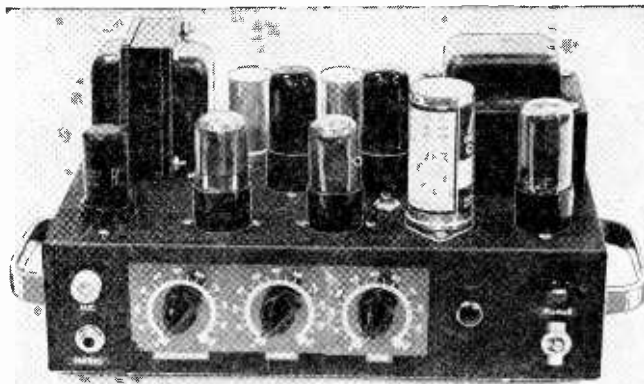

Fig. 2.

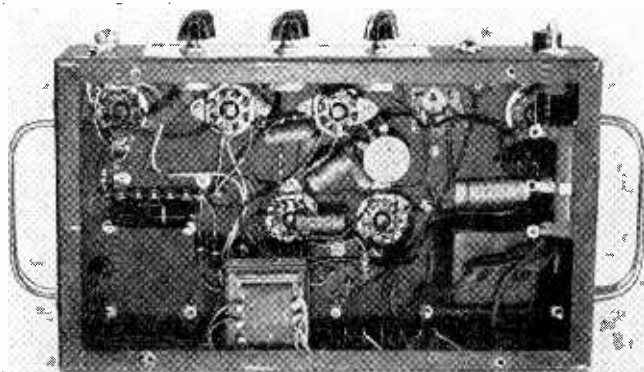

Fig. 3.

study of the chassis and the circuit beforehand may help you to avoid difficulties. Personally, I like to actually lay the parts on the chassis in their proper place, rearranging the parts slightly to give a better visualization of the final appearance before actually wiring the parts into place.

As can be seen in Fig. 3, conventional "point-to-point" wiring was followed. That is, the leads and parts are connected directly between terminals, and special mounting boards are not used for small parts.

In wiring an amplifier, I usually wire the primary and the filament circuits first, connecting the high voltage leads to the plates of the rectifier tube, but not connecting the filter components. After wiring the primary circuit and the filament circuits, I usually plug in all the tubes and turn the amplifier on to see that all tubes light. This test serves a dual purpose—it serves as a check on the wiring completed thus far and also serves as a check on the condition of the tubes and

power transformer. This is particularly valuable where used parts are employed.

Of course, before installing a used power transformer or used tubes, any test that you can easily give the parts should be made. An ohmmeter check is often good but does not always indicate how a part will stand up in operation.

In wiring the amplifier, a screw-type terminal strip was provided for the output. Spade lugs are used on the speaker leads and connections made in a conventional manner. This was done so that one, two, or more speakers may be used as desired or so that some other device might be connected to the output.

If you intend to use your amplifier primarily for public address work, where both speakers will probably be connected at all times, then it is preferable to use sockets of some sort, either octal sockets or ordinary two connector receptacles, with plugs mounted on the speaker leads. This permits more rapid installation of the P.A. system and avoids the necessity for carrying a small screwdriver with you.

Using Substitute Parts

While the cost of this P.A. system will easily exceed that of a commercially built system if all the parts are purchased individually by the constructor, a considerable savings might be experienced if the builder already has parts in his possession that can be used.

This is particularly true as far as major component parts such as the power transformer, filter choke, output transformer, filter condensers, tubes, and chassis are concerned.

It is not necessary to use a commercial "amplifier foundation." An ordinary chassis may be used if desired. In fact, an old receiver chassis may be used provided it is large enough for the parts to be installed and provided a reasonably "clean" layout can be achieved.

Any power transformer that approximately meets the specifications given may be used. A power transformer larger than that specified may also be used and will operate somewhat cooler. From a general viewpoint, a power transformer from an 8 tube (or larger) receiver using 6.3 volt tubes may be used. If you have such a transformer available, you can identify the various windings quite easily. Use an ohmmeter to measure the resistance of the different windings and to identify the various leads. The winding with the highest DC resistance is the high voltage secondary winding. That with the next highest value of DC resistance is the primary winding and the two windings with the lowest resistance are the filament windings. Once you identify the primary winding, this can be connected to a line

PARTS LIST

1. Chassis or amplifier foundation (Bud number CA-1751, 12"x7"x9" foundation used at NRI).
2. Bottom plate for foundation.

Electrical Parts (referring to the schematic diagram of figure 4):

- R1—4.7 megohms, 1/2 watt.
- R2—820 ohms, 1 watt.
- R3—470,000 ohms, 1/2 watt.
- R4—100,000 ohms, 1/2 watt.
- R5—27,000 ohms, 1 watt.
- R6—1 megohm potentiometer (microphone gain control).
- R7—1 megohm potentiometer (phono gain control).
- R8—1500 ohm, 1 watt.
- R9, R10—1 megohm, 1/2 watt.
- R11, R12—270,000 ohms, 1/2 watt.
- R13—10,000 ohms, 1 watt.
- R14—1 megohm, 1/2 watt.
- R15—2200 ohms, 1 watt.
- R16—50,000 ohm potentiometer (tone control).
- R17—1 megohm potentiometer (phase inverter control) screwdriver adjusted.
- R18, R19—100,000 ohms, 1/2 watt.
- R20, R21—470,000 ohms, 1/2 watt.
- R22—400 ohm, 25 watt adjustable resistor.
- C1A, C1B—20 mfd., 25 volt dual electrolytic.
- C2A, C2B—10 mfd., 450 volt dual electrolytic.
- C3—.06 mfd., 600 volt paper condenser.
- C4, C5, C7, C8—.01 mfd., 600 volt paper condenser.
- C6, C10—.005 mfd., 600 volt paper condenser.
- C11A, C11B—40 mfd., 450 volt dual electrolytic.
- C12—50 mfd., 50 volt electrolytic condenser.
- CH1—10 henry, 150 ma. filter choke (Merit No. C-3180 used at NRI).
- T1—power transformer: 350-350 volts at 120 ma; 5 volts at 3a; 6.3 volts center tapped at approximately 5a. (Merit No. P-2953 used at NRI).
- T2—Universal output transformer (Merit No. A-2904 used at NRI).
- SW1—single pole single throw toggle switch.
- Tubes: 1—6SJ7; 2—6SN7; 2—6V6; 1—5Y3.
- Miscellaneous:** 6 octal tube sockets, closed circuit jack, microphone receptacle, pilot lamp jewel, bracket and bulb, terminal strips, machine screws, nuts, extractor fuse post and 2 ampere fuse, wire, solder, knobs, etc.
- Accessories:** 2—8" PM loudspeakers mounted in wall baffles, with 50 feet of two conductor line cord attached to each.
- 1—crystal microphone with cord and microphone connector.

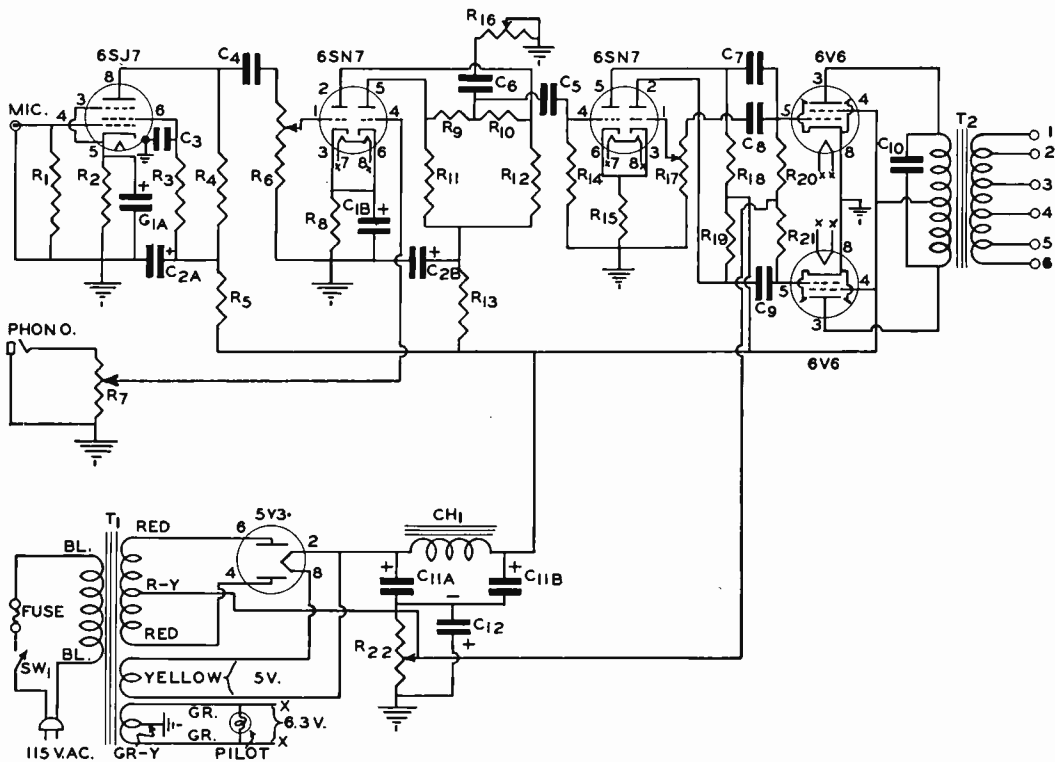

Fig. 4.

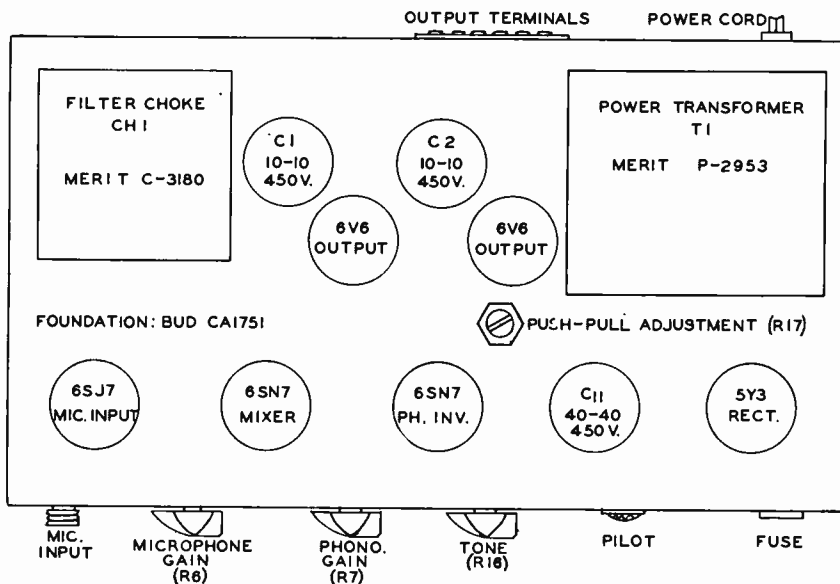

Fig. 5.

cord and the transformer plugged in. You can then use an AC voltmeter to identify the voltage available from the filament windings. Do *not* attempt to measure the voltage available from the high voltage winding.

It is not necessary to use the output transformer specified and any output transformer designed to match push-pull pentodes to a loudspeaker voice coil may be employed. If preferred, a transformer designed to match push-pull pentode amplifiers to a 500 ohm line may be used, but it is then necessary to use a matching transformer at the loudspeaker. Generally speaking, such a step will not be necessary unless extremely long lines are to be run between the loudspeakers and the amplifiers.

If you do not have the proper filter choke available, a small power transformer, from a 4, 5 or 6 tube AC receiver may be used instead. Use the high voltage winding as the filter choke leads and tape up the other leads from the transformer. The filter condenser values are not critical, but the capacities should be somewhere between 30 and 50 mfd. in the power supply circuit. As far as the decoupling circuits are concerned, any value between 10 and 40 mfd. is satisfactory (C_{2A} and C_{2B}).

As far as the cathode by-pass condensers are concerned, only 10 to 25 mfd. at 25 volts are required (C_{1A} and C_{1B}). However, if you have a condenser with a higher working voltage available, this may be used. In the amplifier built at NRI, a dual 10 mfd., 450 volt electrolytic condenser was used, even though such a high working voltage was not required in the circuit. A general rule to remember is to use a filter condenser with a capacity at least equal to the specified value and with a working voltage equal to or higher than that specified.

As far as the tubes are concerned, it is recommended that the specified tubes be used for the voltage amplifiers. In place of the 6V6 tubes, however, either 6K6 or 6F6 tubes may be employed. With 6K6 tubes, somewhat less power output will be obtained. With 6F6 tubes, somewhat greater power output will be obtained. In place of the 5Y3 rectifier, a 5U4 or type 80 tube may be used. A type 80 tube, of course, will require a different socket.

Coupling condenser values are not critical and any value up to .05 mfd. will work satisfactorily. In fact, the larger the size of the coupling condensers used, the better the low frequency response of the amplifier.

If one megohm controls are not available for R_6 , R_{17} , and R_7 , then .5 megohm controls may be used instead.

Resistor values, except for cathode resistors, are

not especially critical and resistors with a coded value within 20% of the values given are satisfactory. The resistors used may, in addition, have a 20% tolerance.

The only large wattage resistor used is R_{22} . Although a 25 watt adjustable resistor is specified, this may be a 50 watt if you happen to have one available. The resistance may be any value between 300 and 500 ohms.

Instead of the two 8" p.m. speakers specified, any size loudspeakers may be used. A single 10" or 12" speaker may be used if desired. However, if the maximum power of the amplifier is to be used in any specific application, then at least two 8" speakers or 1—12" speaker should be employed. For test purposes, a 5" p.m. speaker is satisfactory.

A toggle switch need not be used unless available. An ordinary control switch on the back of the tone control may be used instead. Similarly, the pilot light need not be used if cost is a factor.

Thus, by using substitute parts, and by eliminating the "frills" such as the pilot light, and the use of a commercial foundation unit, it is possible to cheapen the construction cost considerably. If the builder happens to have a few of the major components available, it is possible to build the amplifier for under ten dollars.

"Dressing Up" the Amplifier

To provide the commercially built "finished" appearance, it is preferable to use a commercial amplifier foundation consisting of a chassis and cover. Knobs are provided for each of the controls and these knobs should be all alike. An extractor type fuse post and a pilot light jewel are used.

For the dials and for the titles, either commercially available dial and name plates may be employed or "decals" such as are used on this NRI built amplifier may be employed. The decals can be purchased in sets from most local supply houses and most mail order supply houses. The cost is comparatively low. There are several brands of decal sets available. The exact method used in applying the decals will depend on the type you purchase. For those used at NRI, the decal was first cut to size, dipped in water, then allowed to soak on the workbench for about a minute. The surface where the decal was to be applied was cleaned and moistened and the decal simply slid off the backing paper on to the chassis. After this step, a soft rag was used to press out the water and to smooth the decal down so as to remove water from underneath and to remove air bubbles. After all decals were installed, the chassis was put aside and allowed to dry overnight.

By using a commercially available foundation and using decals for "decorating" the amplifier, a unit can be built that is hard to distinguish from a commercially built job.

Amplifier Adjustment

Once you have completed the wiring of the amplifier, connect a test loudspeaker to the proper output terminals. If you use a universal output transformer, refer to the instruction sheet supplied with the transformer to determine which terminals to use to match your particular loudspeaker.

Connect a DC voltmeter from the adjustable tap of R_{22} to ground, with the positive lead of the voltmeter connected to the chassis. Plug the amplifier in, turn it on and allow a few seconds for "warm-up." Adjust the tap on R_{22} until approximately 20 volts are measured. This value is not critical and any value between 20 and 25 volts is satisfactory. This adjusts the bias on the output push-pull amplifiers.

Now, supply a steady signal of some sort to the input of the amplifier and turn the gain control up slightly. This signal may be supplied either to the phono input or the microphone input. It can be an ordinary hum signal or can be an audio signal from a signal generator such as the NRI Professional Model 88. In any case, it should be a steady note of some sort.

With the steady audio signal supplied, use an AC output meter to measure the voltage between the grid of the upper push-pull amplifier tube and ground. (Referring to the diagram in Fig. 4.)

If you do not have an output meter, simply use an AC voltmeter with a .5 mfd., 600 volt condenser connected in series with one lead.

Now, transfer the lead to the grid of the lower push-pull amplifier and adjust R_{17} until an AC voltage is read here equal to that measured on the other grid.

Transfer the probe back to the first grid to see if the signal voltage is changed. If so, again transfer the probe back to the lower grid and readjust R_{17} . Two or three adjustments in this manner should insure that the drive to the individual push-pull tubes is equal.

"Phasing" the loudspeakers: If two speakers (or more) are connected to an amplifier at the same time, precautionary steps must be taken to insure that the sound coming from the individual speakers reinforces rather than cancels. That is, if the cone of one speaker moves "out" on a particular sound peak, the cone of the other speaker should move in the same direction.



Connecting the loudspeakers so that this happens is commonly called "phasing the loudspeakers." This job can be easily done if the loudspeakers used are all the same kind and manufacture. Simply connect the terminals of the speakers to corresponding terminals on the amplifier. Where a speaker cord is left connected to the loudspeaker, identify one of the wires so that you can always be sure to properly connect

the loudspeaker to the amplifier. In the case of the system built here at NRI, a small piece of black scotch tape was wrapped around one of the spade lug terminals on each of the speaker connecting leads. The terminals with the black tape are always connected together and the two plain terminals are always connected together.

If you are using speakers of different manufacture, you can determine the proper connections by using a small flashlight battery. Connect the battery across the voice coil terminals and watch the direction in which the cone moves. Determine the polarity which causes the other speaker (or speakers) to move in the same direction. The terminals identified in this manner are the corresponding terminals and should be connected together when the speakers are connected to the amplifier.

A high impedance microphone, preferably an inexpensive crystal "mike" should be used with this amplifier. For the phonograph, use any standard player or changer with a medium or high level output.

Application

A small P.A. system, such as this one, may be used in many different applications by the service technician. First, it can be sold to anyone needing such a system such as a club, business firm, church, or similar group. If selling the system, the price to charge depends upon the cost of building the system, the time required, and whether or not the system is sold "installed." The price also varies with locality due to varying labor charges in different parts of the country.

Occasionally, a club, church, or other group may not wish to buy an amplifier system but may simply wish to rent the system for an evening or for a day or so. In this case, the charge will depend upon whether the operator must be present to manipulate the gain controls or whether the system can simply be turned over to the renter for a few days or for the evening. If the system is to be rented for an evening, an average charge is from fifteen to twenty-five dollars, depending upon whether it is necessary to install the system or whether it can be simply turned over to the group, letting them install the system themselves. If it is necessary for an operator

to be with the equipment to adjust the gain for different speakers, fade in the phonograph, etc., then the charge will run between \$25 and \$50 for an evening. There may be some variation from the figures quoted above in different parts of the country, depending upon local conditions.

A small P.A. system such as this one may also be permanently installed in a manufacturing concern, in a store, or in a similar location. It may be used either for paging and making announcements or, in a store, might be used for playing phonograph music during the day. Simply connect a record changer rather than an ordinary phonograph to the "phono" input. The speakers can be permanently mounted on the wall at different points in the store.

More than two speakers can be used with the system if desired in an application of this type. As additional speakers are used, the power delivered to each speaker is reduced, of course. However, where a low level of sound is desired, as in the case of background music, this is not too important. As many as six or eight speakers may be connected to the amplifier.

When connecting additional loudspeakers to the amplifier, it will be necessary to select different output terminals so as to insure a proper impedance match. Assuming that the speakers used are all of the same type, simply divide the impedance of an individual speaker by the number of speakers used to determine which output terminals are employed. As an example, if four loudspeakers are used, each with a voice coil impedance of 8 ohms, then the total impedance is two ohms. The output terminals selected should be those that will match the output tubes to a 2 ohm load. The correct terminals will be found in the instruction sheet supplied with the transformer.

If you do not know the voice coil impedance of the speakers, a good "rule of thumb" to follow in determining the value is to measure the voice coil DC resistance with an ohmmeter and multiply this value by 1.5.

Thus, the service technician cannot only obtain a good deal of enjoyment from building a small amplifier system, but may use the system to increase his earning capacity.

n r i

Industry News Briefs

Sales of cathode ray tubes for Television receivers during the first nine months of 1949 were nearly double the value of such sales during the entire year 1948, according to the Radio Manufacturers Association. Picture tube sales totaled 2,129,210 units valued at \$62,525,446 in the first three quarters of 1949, compared with 1,309,176

units valued at \$33,459,554 for all of 1948. 65% of the picture tubes sold to set manufacturers in the period were 12 inches or larger, whereas in 1948* tubes of this size represented only 6% of sales to manufacturers, the RMA reported.

The first transcontinental television transmissions from Los Angeles to New York probably will travel through San Francisco and eastward across the Rockies and corn belt into Chicago, the Los Angeles Chamber of Commerce was told by Ernest H. Schreiber, Pacific Telephone and Telegraph Company, at a meeting of the C. of C. TV Committee recently. When such service will start is still an unanswerable question, Mr. Schreiber added. A coaxial cable already extends between Los Angeles and New York, but from St. Louis to Los Angeles it is being used only for telephone message circuits. A Los Angeles to San Francisco link is set for next year and "extensions undoubtedly will be made from this initial west coast network. As the enthusiasm mounts here (in Los Angeles) and throughout the nation, the goal of a coast to coast network will be achieved."

J. M. Smith (son of the President of NRI Recently prepared a one-hundred page bibliography of Television between the years 1946 and 1949. This was done as a project of the Educational Committee of Television Broadcasters Ass'n.

n r i

Coin Operated Television



The above illustrates an experimental coin-operated TV set. Built by General Electric, the project is being carried on experimentally in Hoboken, N. J. Each booth set operates as a "slave" to a master receiver. A coin mechanism collects five cents for each three minutes of viewing.



Student's Bench

Here is a picture of the neat bench built by Joseph J. Ebert of Richmond Hill, N. Y. Among other things it shows the NRI Tester and the NRI superheterodyne receiver built by Mr. Ebert. The cabinet is also the work of Mr. Ebert following design and instructions in a recent issue of NR News. The little lady with the mischievous eye is his daughter. Mr. Ebert says: "It is difficult to explain the joy I received when I plugged in the set and it began to play."

Oh! Oh!—and here is the P.S. "The picture with my little girl was taken before the tester was dropped from the working bench."

— n r i —

Following is a letter received from student J. E. Hamilton, Palo Alto, Calif.

Regarding report statement number two for Demonstration Kit 1-RK-1, I find it difficult for me to agree that solder, when hardened, is a dull white color.

After conducting experiments which usurped some fifteen linear feet of assorted resin core, acid core (not used on equipment), and plain (no core at all) solder, in an effort to find something that would come out white, I find it still looks silver to me.

I tried matching various globules of hardened solder against: a—white paper, b—the *white* keys on the piano (I'm not that color blind), and c—the bathtub (not on Saturday night). It still turned out silver for my dough.

I also questioned my wife who, under duress, admits to possible *shade* blindness. Her reaction

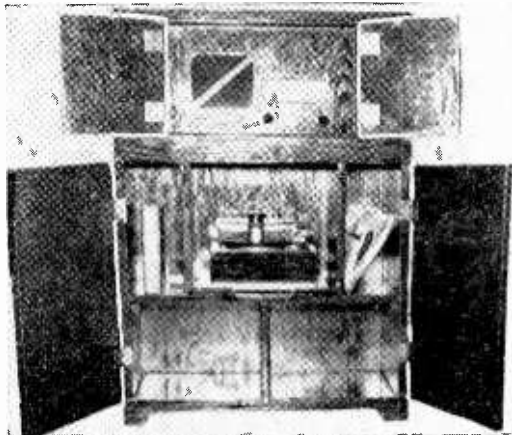

Student's Version of NRI Receiver

"I am enclosing a picture of the radio-phonograph combination I have made using the NRI radio built with experimental parts you sent me. I thought this might be of interest to other students and give them an idea as to how they might put their radio to use.

"I made the radio cabinet out of 1" x 12" white pine and $\frac{3}{4}$ " plywood; using the white pine for the top, sides, and interior shelves and the plywood for the doors. The size of the cabinet is 24" wide and 33" high. I installed the radio in the top section and wired a Phono-jack through the first audio tube with a switch so you can change from radio to phonograph by turning the switch.

"I purchased an RCA Victor 45 RPM record changer and installed this in the section immediately below the radio with shelves for storing records to each side and below. I finished the cabinet with mahogany stain and then applied two coats clear varnish.

"The record changer can be purchased for \$12.95 and it cost approximately \$25.00 for the material to build the cabinet, which can be built without the aid of any power tools.

"I receive a great deal of enjoyment working with radio during my spare time."

DARELL S. SMITH,
Lima, Ohio.

was, and I quote: "Just the color of that Silver Fox I saw up town today! This 'Fox,' priced as I have started pricing things lately, at a mere eight hundred and seventy assorted vacuum tubes and one and one-eighth coils of number twenty solid tinned pushback wire."

The Social Impact of Television

The social impact of television may be greater than the social impact of the atomic bomb, E. Finley Carter, vice president in charge of engineering for Sylvania Electric Products, Inc., told a meeting of the members of the American Association for the Advancement of Science.

"SINCE the advent of the atomic bomb," Carter said, "there has been increasing evidence of an awakened sense of social responsibility on the part of scientists. Much has been said about the bomb and its effect upon society. But it may be that its social impact will not be as profound as will be that of television."

Carter stressed the popular presentation of scientific personalities to the public as a force tending to isolate scientists and engineers from social obligations by saying, "The scientist, like the cleric, has too often been typified by movies, as well as by some business men and industrialists, as a long-haired dreamer. This is partly a satisfying defense mechanism which often salves peoples' egos to make oddities of those who are versed in the things that they do not understand.

"However, the label has been earned by those who have allowed the cold logic of precise mathematical expressions or physical formulae to crowd out an understanding of the human equations associated with the society in which we live.

"Paradoxical as it may seem, television may encourage a cool aloofness to human society by causing one to withdraw into the confines of his own home, or it can make him a citizen of the world through arousing finer emotions and broadening fields of interest. It is my opinion that the latter influence can prevail and that, we can study, through television, the needs and interests of society at large and so develop a keener sense of our own social responsibility."

This will not happen, Carter warned, without effort by men and women in scientific and engineering fields with vision to see beyond immediate dollar profits. "Nothing can destroy our present social system quicker than the exploitation of men and products for monetary gain alone. Where the product has the social significance of television, the moral responsibility is great.

"It behooves those of us who prize our free enterprise system," Carter stated, "to take stock of where we are going and to apply our knowledge and our vision toward the direction of the use of new developments to make a better society.

"The scientist and engineer, because of the increasing technical complexities of our civilization," Carter continued, "must be prepared to accept more active leadership in business and political fields." He said that this trend has already begun and is reflected in a survey made by the Massachusetts Institute of Technology which revealed that more than six hundred of the Institute's graduates are corporation presidents. Television, he predicted, will increase the need and opportunity of engineers and scientists to serve through business leadership.

He concluded his address by saying that man can and must be master rather than a slave of his scientific and engineering creations but he warned that the balance can be easily tipped in the direction of making man the slave. "The secret," he said, "lies in learning to know people and in getting them to understand each other and to work together. That alone can make a harmonious and progressive society. Television can be both an incentive and a means for accomplishing this."

Still Smaller Midget Electrolytics

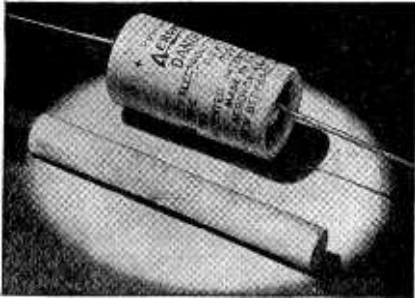

In keeping with the trend towards still more compact radio-electronic assemblies, Aerovox research now comes up with the latest Type PRS midget-can electrolytic capacitors in new reduced sizes. This fact is dramatized in the accompanying illustration showing an Aerovox Type PRS 450 volt 8 mfd. Dandee alongside a regular size cigarette. This new Dandee measures only 13/16" in diameter by 1 1/2" long!

These smaller metal-can electrolytics are available in single-section ratings from 25-700 D.C.W., 4 to 100 mfd., and again from 25 to 450 volts D.C.W., 8-8 to 100-100 mfd., dual-section units. In the high-capacitance low-voltage series the DandeEs are available in voltage ratings from 6 to 25 D.C.W., 100 to 2000 mfd. Recent refinements in the electrolytic capacitor art account for the reduced size of these Dandee electrolytics offered by Aerovox Corporation of New Bedford, Mass.

— n r i —

Folks Are Funny That Way

Strangely enough the folks most apt to lend a hand to you
Are those who are already rushed with countless things to do.
And should bad luck befall you and misfortune smack you prone,
The ones who'll help you most are those with troubles of their own.
The folks whose sunny slant on life helps heal its smarts and stings
Are often those who know first-hand the seamy side of things;
And he was right, it seems, who said that life is what you make it.
It's not so much what happens, as the way in which you take it.

— n r i —

Professor: "What happens when the human body is immersed in water?"
Co-ed: "The telephone rings."

Our Cover Photograph

Here is a success story which will provide inspiration for anyone who may doubt his ability to succeed in the radio servicing profession. Graduate George Ott, Jr., of Meadville, Pennsylvania was chosen as the subject for this issue's cover photograph. Approximately ten years ago, at the age of twenty-four, Graduate Ott lost the use of both his legs. For many months he was confined to his bed, and was forced to undergo a series of operations in order that he might enjoy the freedom of movement afforded by a wheel chair. Ott enrolled with NRI on December 23, 1943. Since that time his record has been one of steady progress—a record which might well be envied by many of us who are not handicapped in any way. Here is the story as Graduate Ott tells it:

"I was injured and am crippled so that I am not able to walk. However, I am doing fine in Radio and Television. If I can learn and earn money in the Radio and Television service field in my condition, there is no reason why any able bodied person can't do the same. Also, Radio and Television should be wide open for the disabled of the past war.

"I have just included in my new shop the RCA Test bench, complete. I also still have my bench which is equipped with Precision equipment. I have another complete bench fixed up for auto radio repair.

"We have just taken on Montgomery Ward's Television service and installation. Have this along with two other local furniture dealers and our own sales.

"We have a stock of approximately \$3500. We do not build our business on the merchandise we sell. We sell service—we have found it pays! At service you can get big, plenty big, and still stay small. I am new at radio (only five years as of now), but I have made myself felt in this whole area because I have a better understanding of radio than the average radio man (thanks to NRI) and now on TV I have a big jump on most of them.

"I have another NRI student, Nicholas J. Mulchin, working for me. He is studying under the GI Bill. We have been doing a lot of Television service—everything from 7 inch to 16 inch sets. We are also doing a wonderful job on sound. During the county fair season in this area, we are kept busy moving our equipment around. I have made the sound installation for a drive-in theatre, and have installed over 50% of the sound systems used in our local clubs.

"Still get along with the wheel chair. Now have my own car and drive it myself. It has a special built-in trottle and air brakes. For all this I thank NRI." Very sincerely yours, **George Ott, Jr., Meadville, Pennsylvania.**

Interpretation of TV Test Patterns

By WILLIAM F. DUNN

NRI Consultant



William F. Dunn

THE TV receiver is unique in that when a defect occurs, it displays symptoms which, to the alert serviceman, point to the cause of the defect. No other piece of electronic equipment indicates so clearly the nature of the defect.

Many servicemen make use of the test pattern in judging the performance of the receiver; it's probably the best indication of the receiver's performance. Practically any defect that will be encountered in the picture, sync, or sweep circuits will show in some way. By learning the effect of the common defects on the test pattern and by learning exactly what information the test pattern may convey, the serviceman can be sure that each set is in peak operating condition when it is returned to its owner.

There are a large number of test patterns in use by the various stations. However, the test patterns shown in Figures 1 and 2, or slight modifications of these patterns, are used by a large number of stations.

By studying these patterns and the information they convey, a great deal of useful data may be assembled. In cases where the local TV stations do not use one of the two patterns shown, the chances are that information on the test pattern employed may be obtained by contacting the station. The information that may be given by the test pattern will be discussed later.

Perhaps the most common or widely known uses of the test pattern are in focusing, centering and adjusting the linearity of the receiver. These are rather obvious uses of the test pattern, but still it would be well worth while discussing these uses of the pattern before going into some of the less familiar details. The test pattern is invaluable to the serviceman in making linearity adjustments.

Improper Focus

Many TV receivers have the focus adjustment on the back of the chassis. It must be set for best over-all focus by the serviceman. The effect of improper focus is shown in Fig. 3.

Notice that the entire picture is blurred. This can usually be corrected quite simply by adjusting the focus control. The control should be adjusted for best or sharpest focus while watching the narrow end of the vertical wedge. The focus should then be checked on the narrow edge of the horizontal wedge. If best focus on

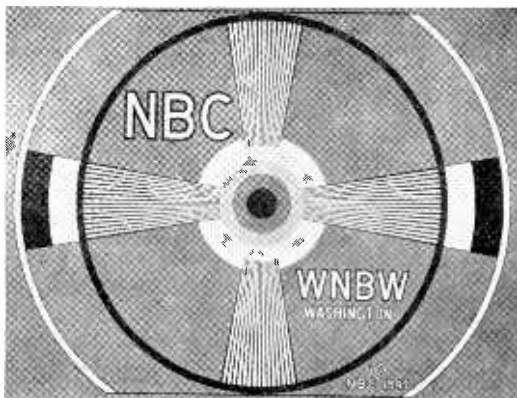

Courtesy of NBC

Fig. 1. Normal NBC Test Pattern.

both the horizontal and vertical wedge is obtained at the same setting of the focus control, we know the spot is round, whereas if best focus on the two wedges is obtained with two different settings of the control, the spot is not round. This may simply be due to improper positioning of the focus coil and/or the ion trap magnet. If this is the case, it can be corrected by readjusting their position.

In some cases, when the spot (end of the electron beam) is not round, it is due to the fact that the aperture in the second anode disc is not round. When the ion trap magnet is improperly adjusted the electron beam may bombard one side of the opening. The mass of the electrons is small, but there will be so many striking the disc at a very high velocity that they can burn away a portion of the side of the aperture. Once this hole has been burned so that it is no longer round, it will be impossible to focus the electron beam to a round spot.

It will frequently be impossible to obtain a good over-all focus. In other words, it may be possible to obtain a good sharp focus at the center of the pattern, but the outer edges of the pattern may be blurred. If the focus control is readjusted, the outer edges can be brought into focus, but this will result in the center of the pattern becoming slightly blurred. This lack of over-all focus is usually due to the tube construction rather than a defect in the receiver and the serviceman should recognize the fact that there is nothing that can be done to correct

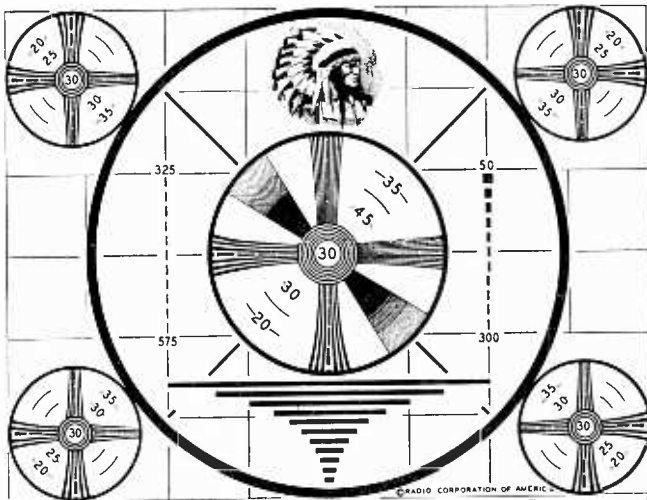
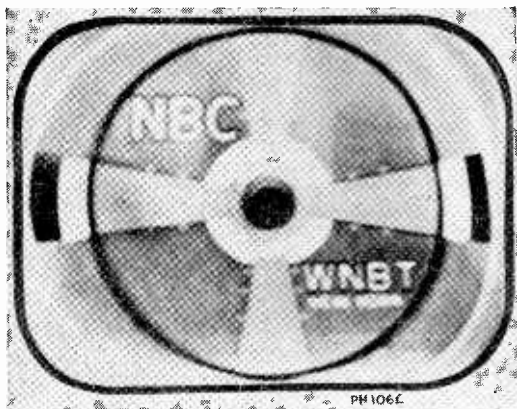

Fig. 2. The RCA Indianhead Test Pattern.

this difficulty. Actually, the blurring is not too noticeable and when a program is being viewed usually will not be objectionable.

Poor Linearity

A horizontally elongated picture such as shown in Fig. 4 usually indicates improper setting of the horizontal drive, width, or horizontal linearity controls. The three controls must be adjusted together in order to obtain a linear picture. Frequently the linearity and width controls will not have too much effect on the picture, but if all of the components in the horizontal sweep are in good condition, they will usually have sufficient effect to make it possible to control



Courtesy of RCA

Fig. 3. Appearance of test pattern showing incorrect focus adjustment.

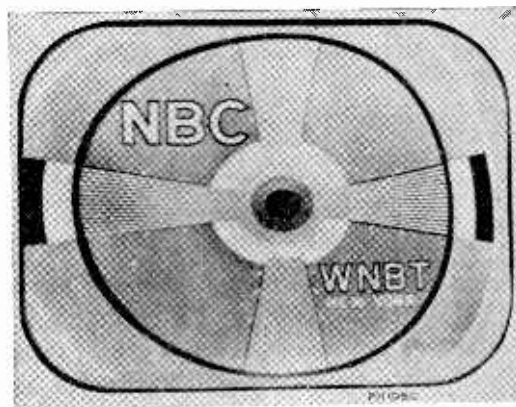

Courtesy of RCA

Fig. 4. Horizontal linearity control incorrectly adjusted.

the linearity of the picture reasonably well.

If adjustment of these controls fails to correct this trouble, it's probably due to failure or a change in value of some component in the horizontal deflection circuit. Perhaps the most common offender is the horizontal output tube, and therefore when this trouble is encountered, a new tube should be tried. The service information on the TV receiver usually gives additional information on this type of trouble and how to correct it.

Poor vertical linearity produces the same effect except the distortion appears in the vertical direction. It is usually due to improper setting of the height and vertical linearity controls. If adjusting these controls fails to clear up the trouble, as in the case of poor horizontal linearity, the trouble is due to some defect in the vertical sweep circuit.

On some receivers it is impossible to obtain a perfectly linear picture. It should be recognized in these cases that the design of the set is such that only reasonably good linearity may be obtained and certain imperfections must be accepted. In addition, the TV transmitter frequently may be the cause of poor linearity. By examining the patterns on several stations (in locations where more than one station is operating) the test patterns may be compared. Certain variations in the linearity may be noticed. In this instance the linearity may be adjusted for a compromise on all of the stations or it may be adjusted on one of the stations that is considered the most reliable and the one most likely to be transmitting a linear picture.

Positioning and Size

The test pattern may be used to check the positioning and the size of the picture. The positioning and size controls should be adjusted together so the size of the picture is slightly larger than the mask and so the picture is properly centered.

The picture should be slightly larger than the mask in order to conceal variations in the positioning of the picture. Variations will occur in the positioning of the picture due to variations from station to station. If the picture is adjusted so that it is just large enough, the variations in picture positioning will be objectionable. A border may appear on one side of the picture, but if the picture is deliberately made larger than normal, this change in picture positioning will be unnoticeable. On the other hand, this must not be carried too far or a portion of the picture will be lost.

Poor Interlace

Poor interlace may be detected by examining

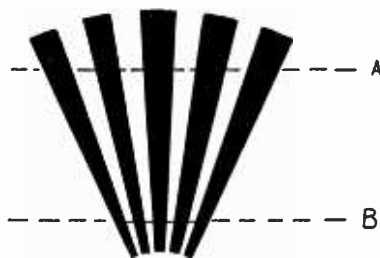

Fig. 5. Simplified drawing of the vertical wedge in a test pattern.

the narrow ends of the horizontal wedges of Fig. 1. A wavy effect indicates improper interlace. This may frequently be due to improper vertical sync; adjustment of the vertical hold control may clear up the trouble. On some receivers, particularly the low price seven-inch sets, this trouble is always present. It is basically due to compromises in the receiver design and there is nothing practical that the serviceman can do, because it would be impractical to attempt to redesign the receiver.

The Video Signal

Before going into additional uses of the test pattern, let us review the manner in which the TV picture is produced. The picture is made up of a series of horizontal lines across the face of the picture tube. These horizontal lines are produced by the horizontal sweep circuits. The vertical sweep moves each line slightly below the previous one so a raster will be produced. The horizontal lines are interlaced so that the odd numbered lines are produced and then the even lines placed in between them. The picture is produced by applying a video signal to the grid of the picture tube. This will cause the beam current to vary causing the illumination to vary over the face of the picture tube. By synchronizing the sweep circuits of the TV receiver with the TV transmitter, the video signal applied to the grid of the picture tube will reproduce the original scene.

The video signal is frequently distorted by the TV receiver. The signal consists of frequencies as low as 5 cycles per second and as high as 4 megacycles per second. Obviously this places some very exacting requirements on the TV receiver. Any loss of signal at the high or low frequencies is apparent in the picture as also is any phase shift in the signals.

Fig. 5 shows a portion of one vertical wedge of a typical test pattern. The wedge consists of a series of vertical lines. As the electron beam is swept across the face of the picture tube, a video signal must be applied to the grid of the picture tube that will cut off the beam current and keep it cut off as the beam sweeps across the line.

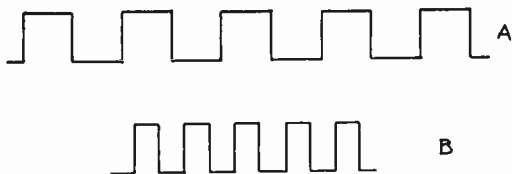

Fig. 6A. Video signal required to produce the portion of the wedge at line A in Fig. 5.

Fig. 6B. Video signal required to produce the portion of the wedge at line B in Fig. 5.

Actually, it will take the beam comparatively little time to cross the line. The main requirement of the signal is to be able to cut off the beam current almost instantly and then to permit the beam current to start flowing just as quickly as the line has been crossed. The signal that must be applied to the grid of the tube at line A to produce the desired wedge is shown in Fig. 6(A).

Notice that for each line there must be a video signal. The signal is such that it must rise rapidly to its maximum value. Then it must remain at this level as the beam sweeps across the line and then drop rapidly to zero. The closer together the lines the higher the rate at which these signals must occur. This means that the receiver must be capable of passing a higher frequency signal to reproduce the vertical wedge near the center of the test pattern than at the top.

Examining Fig. 5, we see that the lines in the vertical wedge converge towards the bottom of the wedge. This means that in order to reproduce this portion of the wedge, the signals will be spaced much closer together in order to reproduce the wedge at line B. In a set having poor high frequency response, the wedge may be clear at the top of the patterns and become somewhat blurred or completely indistinguishable towards the center. The test patterns may be used to determine the actual frequency at which the response of the set falls off. This use of the test pattern will be discussed later.

The examples shown in Fig. 6 represent fairly simple video signals. As might be expected, the signal is far more complicated in most cases. Fig. 7 shows one line of the RCA Indian Head Test Pattern at the point indicated. It can be seen that the video signal in this case is not a simple signal as was illustrated in Fig. 6.

Actually the video signal may be far more complex than Fig. 7 in the case where an actual picture rather than a simple portion of a test pattern is being reproduced.

Definition

The definition or resolution (the two terms are used interchangeably) is the ability of the TV receiver to define or bring out clearly the fine details in the picture. If the receiver has good definition it will reproduce the small details clearly, but if the definition is poor the fine detail in the picture will be fuzzy or blurred or perhaps even completely lacking.

When discussing resolution, we refer to the horizontal and vertical resolution. The two are not the same, the definition from top to bottom, which is the vertical definition, is usually somewhat better than the horizontal resolution. We shall now see what affects the resolution and what defect poor resolution in one direction may indicate.

Vertical Resolution

The vertical resolution determines the number of horizontal lines that can be resolved. It depends primarily on how sharp the electron beam can be focused. The band width of the receiver will have no effect on vertical resolution. It is simply the ability of the receiver to define a given number of lines from the top to the bottom of the picture.

There are a total of 525 horizontal lines in each frame. This standard is set by the FCC. However, this does not mean that there will be this many lines in the picture because a number of lines will be lost during the vertical blanking period. Actually the total number of horizontal lines available would be only 490. Therefore, providing the electron beam could be focused to a small enough spot, we could not obtain a vertical resolution of better than 490 lines. The resolution is usually somewhat less than this figure shows.

The actual vertical resolution may be determined by a careful examination of the horizontal wedges. Fig. 8 shows how the dots and rings are used to determine the resolution. If the horizontal wedge were clearly defined up to the outer portion of the white ring, the vertical resolution would be 300 lines. If the wedge was repro-

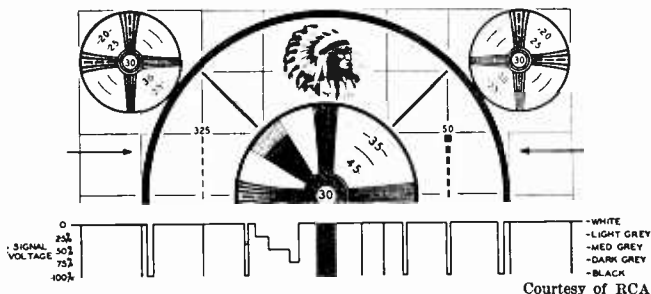

Fig. 7. Wave form of the video signal along one line of this test pattern. (Arrows indicate portion of test pattern illustrated.)

duced all the way to the center, the vertical resolution would be better than 325 lines.

The Indian Head Test pattern also shows the resolution. The last zero has been dropped to keep the lettering on the pattern to a minimum. To determine the vertical resolution, determine how far the horizontal wedge is defined and remember to add the zero to the figure obtained from the test pattern.

As mentioned previously, the vertical resolution depends primarily on the spot size—poor vertical resolution will therefore be encountered if the beam cannot be properly focused due to some defect in the picture tube or due to improper positioning of the focus coil or ion trap magnet. In addition, incorrect current flow through the focus coil will produce this effect.

Horizontal Resolution

Since the vertical resolution depends on spot size, as might be expected, little or no trouble is experienced due to poor vertical resolution. However, the horizontal resolution is affected by both the spot size and also the band width of the receiver. Since there are many defects that can reduce the receiver bandwidth, poor horizontal resolution is quite common.

The horizontal resolution in lines is the number of lines that can be produced in three-quarters of the usable length of the horizontal scanning line. It is determined by examining the vertical wedges. A set that has poor horizontal resolution usually can define the vertical wedge at the top and bottom because the lines making up the wedge are spaced a reasonable distance apart. Reproducing these lines does not require any great band width in the receiver. However, as the lines move in towards the center, they come closer together. The closer to the center, the greater the number of lines the set must be capable of reproducing. A receiver that can define the lines all the way to the center has good horizontal resolution. This is the ideal condition and while it cannot be achieved in many sets, the closer to it the better.

In Fig. 8, the numerals on the top vertical wedge indicate the number of horizontal lines that may be resolved. To reproduce the vertical lines at the top of the wedge, the set must have a horizontal resolution of at least 150 lines. If the lines are reproduced down to the first dot, the resolution is 200 lines. It can be seen that the horizontal resolution may be determined by noting how far towards the center the lines in the vertical wedge are reproduced.



Fig. 8. A normal test pattern showing calibration.

Courtesy of NBC

Since the horizontal resolution depends primarily on the receiver bandwidth (assuming that the beam can be properly focused to a small spot) it would be advantageous to express the resolution in terms of receiver bandwidth.

One complete horizontal line will take 63.5 microseconds. Deducting 10.2 microseconds which is the horizontal blanking time, the usable portion of the horizontal sweep is 53.3 microseconds. Since we are interested in only $\frac{3}{4}$ of the usable length of the line, the length of sweep we are interested in will take 40 microseconds. From this information, we can convert the resolution in lines into bandwidth in megacycles.

In 40 microseconds, a one megacycle signal would produce 40 cycles. Each cycle could produce two dots or lines, one black and one white or a total of 80 lines. Similarly a 2 megacycle signal will produce 160 lines, 3 megacycle 340 lines, etc. Therefore, if we have the horizontal resolution expressed in lines, we can convert it to receiver bandwidth in megacycles by dividing the number of lines by 80. In Fig. 8, the figures on the lower vertical wedge have been converted as just described to represent the receiver bandwidth in megacycles. Actually the top and bottom vertical wedges yield identical information expressed either in lines or megacycles.

When the test pattern is similar to the one shown in Fig. 2, the horizontal resolution is first determined in lines and then it may be converted by dividing by 80.

As previously mentioned, poor horizontal definition is usually due to insufficient bandwidth.

The trouble is frequently improper alignment. The alignment may have been correct when the receiver left the factory, but some tuned circuits may have drifted somewhat because of aging of parts in the tuned circuits. If the receiver alignment is touched up using a sweep signal generator and an oscilloscope, this difficulty can be overcome.

Some of the lower priced TV sets are incapable of defining the vertical wedge all the way to the center. This is because the manufacturer has had to make some sacrifice in bandwidth in order to obtain enough gain in the set. The serviceman should recognize this fact and avoid spending needless time on the set trying to improve the definition.

Poor definition may also be due to a defect in the video amplifier. If the video amplifier is incapable of passing the high frequency video signals, it will be impossible to obtain good definition regardless of the bandwidth of the i.f. amplifier. Defective components, such as peaking coils, will cut down the response of the video amplifier.

Low Frequency Defects

Normally the horizontal wedge will be as dark as the vertical wedge. However, if the horizontal wedge is light as compared to the vertical wedge, it indicates that the receiver has poor low frequency response.

When the same condition exists and it is accompanied by a smearing of large elements of the picture, such as the letters in Fig. 9, we have poor low frequency response and also a phase shift at the lower frequencies. This may be due to a defective peaking coil or an open coupling condenser.

A phase shift at the lower video frequencies also produces such effects as the "X-ray effect." This is a smearing of long horizontal objects in the picture. When an object is placed in front of a horizontal object, such as a person standing in front of a mantel, it is possible to see the mantel behind the person giving the effect of an X-ray peering through the person, hence the name, the X-ray effect.

Regeneration in the I.F. Stages

If there is any tendency towards oscillation in the i.f. amplifier, it will show up in the vertical wedge. It has the appearance of a number of fine dark horizontal lines streaking across the vertical wedge. The point at which they cross the vertical wedge indicates the frequency at which the regeneration is occurring. In receivers in which stagger tuning is used, it is frequently possible to pick out the stage in which the regeneration is occurring.



NRI TV Lab Photo

Fig. 9. Poor low frequency response and phase shift.

There are many other defects that produce characteristic indications in the test pattern. However the various defects mentioned are the most common and the information given on these defects should be helpful to the serviceman.

— n r i —

A painter was decorating the ceiling of a room in an asylum when an inmate approached. "Hey you," said the inmate. "Have you a good hold on that brush?" "Yes," said the painter. "Why?" "Well, hang on tight, brother. I'm going to move the ladder."

— n r i —

A woman went to buy a drinking trough for her dog, and the shopkeeper asked her if she would like one with the inscription, "For the Dog." "It doesn't really matter," she replied. "My husband never drinks water, and the dog can't read."

| TELEVISION BOX SCORE | |
|---------------------------------|-----|
| Stations Operating | 98 |
| Construction Permits Granted | 11 |
| Applications Pending | 349 |
| (As of Jan. 1, 1950) | |

How to Get Along With Others

DR. JAMES F. BENDER, DIRECTOR

The National Institute for Human Relations

Copyrighted—all rights reserved

A good companion usually tells good stories. He follows the ten commandments of a good story-teller and thus increases his popularity:

1. **Make the story your own.** If you put it into your own words, transpose a phrase here, add one there, it takes on your personality. Printed stories often need your drastic editing.
2. **Don't be the first to laugh at your own jokes.** All of us have had to smile grudgingly at the speaker who laughs too soon at his own stories.
3. **Don't tell a story until you really like it.** Unless you think it is funny, you will have a hard time to sell it to others.
4. **Work for surprise.** Laughter is release from nervous tension built up throughout the story. If you defer the point to the very last word, tension reaches the laughing point at the best time.
5. **Master at least one dialect.** You may become a specialist in Irish stories. If so, you will want to make them click with a brogue. Good story-tellers often become competent in many dialects, like Peter Donald of radio fame.
6. **Make it conversational.** Mere recital is wooden, but live conversation, direct and in a selection of language geared to the characters, is sure-fire. If the story involves more than one person, change your voice and position to identify the various characters.
7. **Overlearn your stories.** Know them so well that you won't muff them, for a mangled joke falls hard.
8. **Don't tell too many.** Always leave your circle with the wish to hear more. A good story-teller has to guard against the temptation of virtuosity. Two or three first-rate stories pay better dividends than six or seven that may bore your circle.
9. **Tell one on yourself.** One of the best ways to captivate an audience is to get them to laugh at you. This gives them a feeling of superiority. It's good psychology.
10. **Change your stories now and then.** Good stories travel so rapidly these days that they soon become hackneyed. An excellent story has a life-span about as long as a juke-box song. A good story-teller therefore changes his repertoire several times a year.

Finally, remember that a good story-teller never hurts the feelings of his companions. The best stories are wholesome.

Installing Three-way Switches

By LEO M. CONNER

NRI Consultant

THE control of a light from two positions is often desirable. This is particularly true where the light is at the head of a stairway or in the center of a long hall. It is also desirable on occasions to control the ceiling light in a room from two different doors.

Where this type of control is used, three-way switches are required at the control points. A three-way switch is basically a single pole-double throw switch and if you keep this fact in mind while you are looking at diagrams you will have no trouble in visualizing the action.

Fig. 1 shows a simple circuit drawn in conventional circuit diagram form. With the switches in the positions shown the lamp will be on. The circuit is from the source to the center connection of S_1 , through the switch arm to the contact, through wire B to the contact of S_2 , through the switch arm to the center connection of S_2 , from the center connection to the lamp, through the lamp and back through wire W to the source.

Now suppose S_2 is thrown to the down position. Fig. 2 shows the circuit for this condition. The lamp will be off because there is no complete circuit but throwing S_1 down or S_2 up will complete the circuit and the lamp will light.

There is no "no contact" position in a three-way switch—the switch is always closed but the circuit may be completed by throwing either switch because of the method of connection.

Now let us see how a practical control circuit would be installed.

The first step is to decide where the lamp and switches will be located. Then find out where the

closest "hot" line is located. You may use a "hot" line near one switch or a line near the lamp, it makes no difference. (A "hot line" is a circuit which is always energized, to which you can connect this additional lighting circuit.)

Now investigate and determine the path the wire will need to follow between the "hot" line and the switch or lamp and the path the wire will have to follow between the switches. Measure, or estimate, these distances and the distance between the lamp and the closest switch.

The material necessary is:

- 2—3 way switches
- 2—switch boxes
- 2—switch cover plates
- 1—ceiling or wall outlet box (4")
- 1—fixture
- 6—BX connectors

Enough type 14-3 armored cable is needed to reach between the two switch boxes. (This is three number 14 wires in a single armored cable.)

Enough type 14-2 armored cable is needed to reach from the "hot" line to either one switch box or the lamp outlet box and enough 14-2 cable to reach from the lamp box to the nearest switch box.

Let us assume, for example, that a lamp is desired at the head of a stairway. First locate the exact position of the lamp and hold the center of the 4" box over this point. Now carefully mark around the box with a pencil allowing about $\frac{1}{8}$ " margin all around. If the ceiling is made of lath and plaster, carefully cut the plaster out using a sharp chisel. Do not try to remove large chunks but carefully cut along the mark all the way

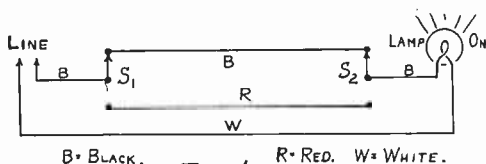

FIG. 1.

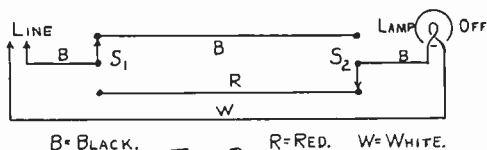
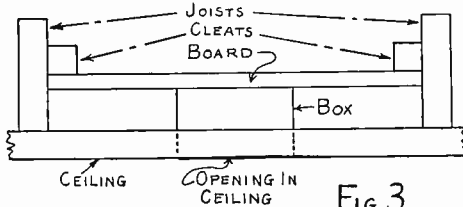

FIG. 2.

around the box outline. Keep going around this line until you have cut down to the lath. Then a few light taps with a hammer in the center of the hole will loosen the plaster so that it can be pulled down.

Next cut through the lath following the hole outline. Wood lath, gypsum lath and the so-called "wall board" may be cut with a "keyhole" saw. Metal lath can be cut with a pair of heavy diagonal cutter pliers or tin snips.

If there is a floor above the opening it will be necessary to open up a space, directly over the



opening, about 5" wide and as long as the spacing between the joists.

A board is then cut so that it is a snug fit between the joists. This board can be any width from three inches on up to the width of the opening in the floor. Next lay the board over the opening in the ceiling so that the center of the board is over the center of the hole. Place the box in the hole and then carefully mark through two of the holes in the bottom of the box. Remove the box and board and fasten the box to the board using wood screws and positioning the box according to the marks on the board. Next two "cleats" should be nailed to the board on the side opposite the box so that the board can be nailed to the joists. Fig. 3 shows how the assembly should be placed. Before permanently fastening the board in place, remove two of the "knockouts" in the box. There are holes punched in the sides of the box so that only a small section of metal holds the "knockout" in place. A sharp blow on the side opposite the solid section will "start" the plug and it may then be removed by twisting with a pair of pliers.

Now remove the locknuts from two of the BX connectors and insert the connectors in the openings of the box. Run the locknuts up and then pull them tight after making certain that the screws which grip the cable can be reached after the box is in place.

The switch box opening should be cut next. The type of wall surface will determine how this should be done.

There are six types of wall covering in common

use; wood lath and plaster, rock lath and plaster, metal lath and plaster, gypsum board, plywood and knotty pine. It is very important that you know the type of wall so that the boxes can be securely fastened in place.

The wall surface is supported by "studding" which, in most cases, is made up of 2×4 's spaced 16 inches on center. This means that the centers of the 2×4 's are 16 inches apart and that there is slightly more than 14 inches of space between the studs. Keep this fact in mind when you choose the location of the switch boxes. Quite often it is possible to locate a stud by examining the baseboard because the baseboard is nailed to the studs and if you can see the nail heads in the baseboard you can assume that they are driven into studs.

Allow about two inches between the edge of the stud and the side of the box nearest the stud and mark the outline of the box. About an eighth of an inch should be allowed for a margin.

After marking, cut through the plaster, if used, for about one inch along each side mark at the center of the space and then carefully remove the plaster from this section. This will show the type of lath used. If it is any type other than wood, finish cutting out the opening and cut the lath out to the same size. If it is wood lath, then expose the complete lath nearest the center of the hole you have marked. Then place the box so that the center of the box is over the center of the exposed lath and re-mark the hole if the location has changed. Cut out the plaster and lath to the new marks.

Now carefully examine the switch box and you will notice metal "ears" fastened at each end with machine screws. There are slots in these ears that make it possible to adjust the position so that the front of the box can be made flush with the wall surface. Set the "ears" in the position shown in Fig. 4. Now place the box in the opening and mark around the ears. Cut out the plaster back to the lath so that the ears can be fastened to the lath with wood screws later on.

Adjust the position of the ears until the front of the box is flush with the wall surface when the ear is pressed back against the lath. If it is not possible to do this, then turn the clamps around and position them so that the box is recessed slightly.

Each end of the switch box should have knockouts in it and the next thing is to knock out both end knockouts in one of the boxes and one end knockout in the other box.

If the wall has any other type of lath, the box cannot be fastened with screws. A patented sheet-metal fastener, known as an Austin "Holdit" is available for holding the box in position. Fig. 5

- shows the outline of this type of fastener. Its use will be described later.

Assuming that you have the ceiling box in place and the openings for the wall boxes cut, you are now ready to run the cable.

Armored cable or "BX" has a spirally wound metal covering so that the cable is fairly flexible. There are a series of spiral ridges, or convolutions, for the length of the cable. In order to strip the metal covering from the wire you use a "hack saw" to cut through a convolution about 8 inches from the end of the wire. Then break the armor and slip it off. The same method is used for either the two or three wire cable. When the armor is removed, the wires will be exposed although they will be wrapped in paper. There may be a small tinned bare wire outside the paper. If so, bend the the bare wire back over the armor and cut off all but about one inch.

When using armored cable, insulated bushings are required to prevent shorts or grounds to the cable. These are known as fiber bushings, "red heads," or red bushings. The bushing is split so that it can be slipped around the wire. It should be forced between the armor and the wire and pushed up so that the shoulder on the bushing is tight against the end of the armor.

After preparing the ends of the two wire cable, feed it down the wall to the switch opening. It probably will be necessary to drill or bore a hole in the "top plate" in order to get the wire down inside the wall. The opening in the wall is large enough to insert your hand and grasp the wire in order to pull it through the opening. Pull enough wire through so that about two inches of the armor is outside the hole. Run the two-wire cable to the ceiling box and cut the cable allowing for an 8 inch "tail" at the box. Remove 8 inches of armor as described above, insert a bushing and then start the end of the wire into one of the connectors. Push the wire in until the end of the bushing is against the inside edge of the connector and the cable end is under the screw. Then tighten the screw on the connector.

Now take a short piece of friction tape and wrap it around the white wire in the box for identification later.

The three-wire cable should now be run between the two switch boxes. In some cases it may be necessary to remove a baseboard and drill through studs in order to get between the proper set of studs. In other cases it might be easier to go into the attic and then drop down between the proper studs or it might be easier to drop down into the basement or under the house. This will need to be decided by the conditions at the place where the work is being done.

Leave 8 inch "tails" on the ends of the three-wire

cable and insert the bushings. Where support is needed, the cable should be held in place by BX staples or approved clamps. Do not use nails.

Next put connectors on each end of the cable. Make certain that the cable is pushed well up into the connector before tightening the screw. Remove the locknuts from the connectors and then start the tails of the wire in the knockout. Push the box into the opening and, if you work carefully, you will be able to work the box into position. Grasp the wire in the lower hole and pull it out until the threads on the connector are inside the box and then start the locknut. Pull it up tight. The upper wire should be pulled into

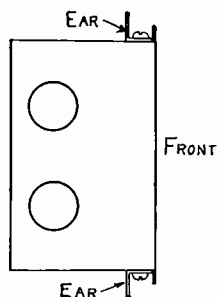

FIG. 4.

position and the locknut put on the connector and pulled tight.

This box is now ready to fasten into the wall. If the wall has wood lath use $\frac{5}{8}$ " wood screws and if it is rock lath, or metal lath use two metal "Holdits." See Fig. 5. One end of the "Holdit" should be started into the hole alongside the box. Then hold the bottom "ear" with a pair of long nose pliers. Push the "Holdit" up and back and when the bottom end is inside the hole, start pulling down and forward. In this manner the top "ear" will be brought out through the opening. The box should be held back firmly and the ears on the "Holdit" pulled as far forward as possible. The ears should then be bent around the edge of the box and back into the box. Do this on both sides. Fig. 6 shows how the box is held in place.

If the wall surface is plywood or "knotty" pine, the box is held in place with wood screws.

One switch box should now have a single three-wire cable in it, the other switch box should have one three-wire cable and one two-wire cable and the box for the fixture should have one two-wire cable in it at this time.

Start at the box with the two cables and remove the paper covering from the wires. This will ex-

pose red, white and black wires in the three-wire cable and black and white wires in the two-wire cable.

Remove about 4 inches of insulation from each of the two *white wires*. Twist these wires tightly together, using a "running splice," for about two inches and cut off the surplus. Now bend the twisted wire back on itself so as to get the sharp

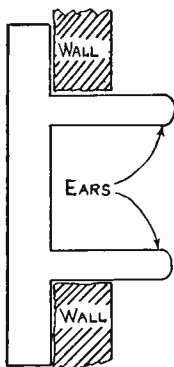

SHEET METAL "HOLDIT." TWO ARE USED FOR EACH WALL OUTLET. METAL EARS ARE BENT OVER EDGE OF OUTLET BOX, SO THE BOX WILL NOT PULL OUT OF THE WALL. FIG. 5.

ends away from the end of the wire. Solder the splice and then tape it carefully using rubber tape and then cover the rubber tape with friction tape. Be sure this wire is covered completely as it will be "hot" at all times. After taping push these two wires well back into the box.

Now locate the common screw terminal on one of the three-way switches. Remove about 4 inches of insulation from the black wire that is in the *two-wire* cable and connect this wire under the common connection screw. Cut off the excess wire. This leaves one red wire and one black wire that are not connected. Connect the red wire under one of the remaining screws on the switch—it makes no difference which one—and then connect the black wire under the other screw.

Use the two 6-32 machine screws that come with the switch to fasten the switch in the box and then put the cover plate on the switch.

The switch box with the single three-wire cable should be connected next. The white wire should be connected to the common screw, the red wire to one of the remaining screws and the black wire to the third screw. Fasten the switch into the box and put the cover in place.

Now you are ready to run a "hot" line to the

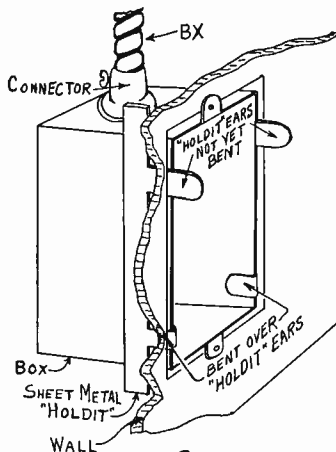

FIG. 6.

light outlet. This may be picked up at the most convenient point. It would be best to cut off the current at the point where it enters the house before working on this part of the job.

After you have decided where you are going to pick up the "hot" line, prepare the end of a two-wire cable the same as for the previous work. Let the fixture down at the outlet which you are going to use as a source of power for your new circuit and remove a knockout from the box. Install the new wire and tighten the clamp on the armor. Now run the cable to the new fixture box and, after removing the armor, insert the wire into the remaining knockout in this box.

There should now be two black wires, one white wire with tape on it, and one plain white wire in this box. Locate the white wire with tape on it and pull it down. The black wire in the same cable with this wire should be pushed back against the ceiling to get it out of the way. Pull the black wire from the "hot" line down and splice it to the taped white wire. Solder and tape the splice and push the wire back up in the box. This leaves one white wire and one black wire.

Now examine your fixture. If it has wire leads, one of the leads will be "identified"—that is, it will be white, or a white wire with a tracer. This wire should be connected to the outer shell of the new fixture's socket. This lead is then spliced to the white wire (going to "hot line"), soldered, taped and pushed up in the box. The remaining wire from the fixture should then be spliced, soldered and taped to the black wire. The fixture should then be attached to the ceiling outlet box using the material supplied with it. If your fixture has screw connections, the white wire should go under the white screw and the black wire under the brass screw.

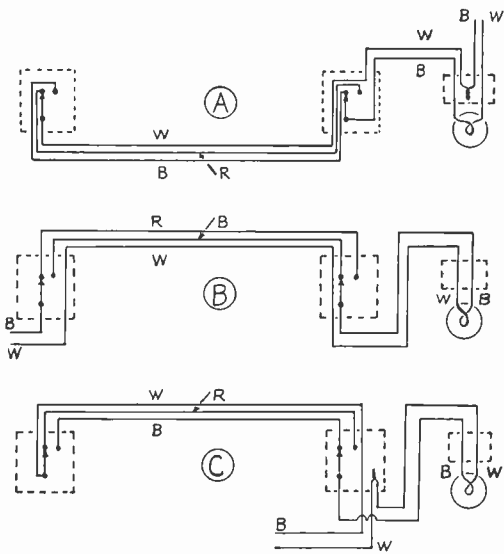

FIG. 7.
 A = HOT LINE AT FIXTURE
 B = HOT LINE AT FAR SWITCH
 C = HOT LINE AT NEAR SWITCH

You are now ready to tap into the line. Be sure the power is off before you start. Locate the white wires in the box from which you intend to get power and splice the new white wire in with these wires. You will likely find one white wire connected in with a group of black wires. This is OK and the white wire is the switch "loop." Connect the new black wire in with these wires, tape the leads and put the fixture back in place. The job is now finished. The method described is in accordance with the National Electrical Wiring Code.

There are a number of methods that may be used to cover different situations. A wiring diagram of the circuit described in the preceding paragraphs is shown in Fig 7A. The switches are in an "on" position. Figs. 7B and 7C show alternate methods of feeding power to the circuit. Use the one method best suited to your purpose.

— n r i —

"For want of self-restraint, many men engage all their lives in fighting difficulties of their own making; while others—who may be much less gifted—make their way and achieve success by simple patience, industry and self-control."

—Samuel Smiles.

— n r i —

A wise man's prayer: May I never be caught talking when I should be listening.

— n r i —

The sermons you hear always seem to fit someone else to a T.



America's Way

Every March the American Red Cross goes to the people of this country for support of its program. This program entails responsibilities decreed by federal statute, responsibilities of national and international scope that continue both in war and peace.

The response of the people is voluntary. It is for each individual to decide how much he can give of his time and his money to assist in carrying out these responsibilities. No one says what the individual must do.

Yet the people—in the little towns, in the rural districts, in the big cities—accept the challenge year after year and voluntarily make the Red Cross responsibilities their business. They take pride in shouldering their neighbors' burdens when the sudden hurricane, the forest fire, the flash flood sweep away homes and possessions. No one tells them they *must* help. They respond to the needs of their fellows in the pioneer spirit of helpfulness that is their heritage.

The response of Americans, not only at fund raising time but throughout the year, to every part of the Red Cross program—blood, safety, service to veterans and the armed forces and their families, nursing, disaster, international activities, and other services—is never failing.

The men in industries and professions, the women in homes and in the business world, the boys and girls in schools and colleges make up the American Red Cross and work THROUGH it, give THROUGH it, with no sense of compulsion.

This is America's way.

— n r i —

New Layout for Back Page Of NR News

No, we didn't get mixed up and set part of the last page of *NR News* upside down, NRI has a new, automatic addressing machine which will greatly speed the mailing of your copy. However, the magazine must be inserted into the machine in a certain way for automatic addressing.

General Electric Reports on Electronics

The following is a year-end statement by Dr. W. R. G. Baker, a Vice President of the General Electric Company and General Manager of its Electronics Department with headquarters at Electronics Park, Syracuse, N. Y. It reviews the general electronics market ahead for 1950, and some G.E. accomplishments of 1949 in this field.

The electronics industry, spurred on by the tremendous sales potential ahead for television and encouraged by a substantial market for radio and radio-phonographs, will set new sales records in 1950. Although television and radio set the pace, fertile markets are being developed elsewhere for other electronic devices in industry and the public services.

TV Receivers

Television dominates the electronics business. The public will spend over \$800,000,000 for TV receivers in 1950, plus \$60,000,000 for installations. To support this demand, the industry is setting its production sights for 3,500,000 receivers—a 30 per cent increase over 1949. Roughly half of these receivers will be table models. The trend will be toward production of more sets with larger picture tubes (12 and 16 inch).

At the end of 1950, television programs will be available to 65 per cent of the American people. Expansion of network facilities, new programming techniques, and the entrance of more advertising dollars in this field will bring over-all improvement in TV entertainment and education.

General Electric, concentrating its television development and manufacture at Electronics Park in Syracuse, N. Y., expects eighty per cent of its receiver business will come from TV set sales in 1950. Models will be priced, styled and engineered with features that will keep pace with consumer requirements.

Color and UHF

Much has been said and written about color and the use of ultra-high frequencies in television. When these feature applications are commercialized by the Federal Communications Commission, General Electric will be ready to supply receivers incorporating these features, UHF adapters where necessary for conversion of present sets, and equipment for the broadcast industry. **In my opinion, color TV will not be available on a national scale for at least five years. UHF will**

develop much faster. It has been said before, but bears repeating, that **the public can buy present-day sets without fear of obsolescence.**

TV Stations

It is difficult to estimate the number of new TV stations that will go on the air in 1950 because of the current FCC freeze on new construction permits. The industry expects the freeze to end sometime in the coming year, but anything more would be guesswork. Ninety-eight VHF (very-high frequency) stations were on the air commercially at the end of 1949. Eleven more VHF stations with construction permits will begin operations in 1950. It is unlikely that any UHF (ultra-high frequency) stations will be on the air commercially in the coming year. One year after the freeze is lifted we estimate 53 additional VHF stations will begin operations, plus an unknown quantity of UHF transmitters. Looking ahead to the end of 1951 I believe the nation will have a total of 300 TV stations.

General Electric at Syracuse is engaged in all phases of TV station equipment development and manufacture. During 1949 the company supplied transmitters and allied apparatus to stations in many metropolitan centers, including the first Italian station at Turin, and the first South American station at Rio de Janeiro. It built the world's highest-gain TV antenna for Station WHAS-TV in Louisville, Ky. Among TV studio developments, G.E. added an electronic viewfinder to its camera to accommodate lower lighting levels and increased sensitivity in the camera's image orthicon tube.

AM and FM Stations

The strength of consumer demand for small radios and radio-phonograph combinations during the last quarter of 1949 surprised many people in the industry. In general, production orders on the factory for combinations had been drastically cut and manufacture of other models trimmed. This added up in the last quarter to comparatively short supply, spirited consumer demand, and

with stocks in manufacturers' inventory and dealers' stores at the lowest level since the war ended.

Forecasts indicate a market in 1950 for over 9,000,000 radio receivers of all types, with a retail value in excess of \$350,000,000. There are countless communities which cannot expect television next year or in five years—perhaps never in the foreseeable future—with whom radio must remain the major and exclusive service. Here, too, the phonograph is a necessity for many hours of leisure. The consumer desire for this type of entertainment will be further stimulated by phonographs now available for playing all types of records, and by continued improvement in the quality of reproduction.

Tubes

The 1950 market for radio and television receiving tubes of all types is estimated at \$175,000,000 at the manufacturers' level. The industry will make roughly 190,000,000 tubes for these applications. This includes about 4,000,000 picture tubes for initial equipment, replacement business and inventory and 186,000,000 other types. The market for transmitting and associated tubes is estimated at \$25,000,000, and at \$10,000,000 for industrial tubes at manufacturers' level.

General Electric continued active development in all phases of this field during 1949, and laid plans for expansion of facilities, especially for picture tubes, in 1950. A new picture tube plant at Electronics Park, to be completed and in full production in the first quarter, will give the company the most modern tube engineering and manufacturing facilities in the world. Over 152,000 square feet of production space will be devoted to this important TV set component. This will be in addition to the company's manufacturing facilities for television picture tubes at Buffalo, N. Y., for receiving tubes at Owensboro, Ky., Tell City and Huntingburg, Ind., and transmitting and industrial tubes at Schenectady, N. Y.

The first G.E. metal-cone picture tubes were introduced in 1949 and requirements are being met for 8½, 12 and 16-inch sizes. Use of the aluminized screen continued and has been supplemented by a dark faceplate.

Germanium diodes, used in many TV receivers, have evolved from a highly specialized device into a standard component, being manufactured by General Electric with high-speed manufacturing techniques. A new UHF (ultra high frequency) germanium diode also was introduced during 1949.

Another new G.E. tube, called the gated-beam receiving tube, opens up an entirely new field of design possibilities, helping to reduce cost.

Two-Way Radio

In other fields of electronic activity, two-way land-mobile radio communications has grown into a sizable business. The market in 1950 is estimated at \$25,000,000. Police departments will spend \$5,500,000 for this equipment; public and REA utilities \$6,700,000; taxicab companies \$2,250,000, and forest conservation agencies \$1,025,000. The petroleum and heavy construction industries, highway maintenance and fire departments, lumber organizations and others will round out the additional orders for the year.

General Electric is a pioneer in this field with experience going back to the early thirties. To meet expanded needs in the industry, General Electric in 1949 developed and shipped new 25-50 megacycle equipment. This was the first so-called "narrow band" equipment and was designed to conserve channel space so necessary to fill the requirements of the industry as outlined by FCC.

Radar

Primary use for commercial radar during 1949 continued to be in the marine field. About 1000 licenses have been granted by FCC since the war for radar on all types of vessels from ocean-going liners to inland craft. At the present rate of growth, 340 vessels will obtain licenses to operate radar in 1950.

General Electric also pioneered this field, having developed the first commercial marine radar in 1945. During 1949 the company initiated a new concept for this industry. Called the Bi-focal Electronic Navigator, this development permits the skipper to study both near and far objects simultaneously. This is done with two cathode-ray scopes, one held at a constant range of two miles, and the other variable from ½ to 40 miles.

The company started production in 1949 of 27 airport surveillance radar systems for the Civil Aeronautics Administration. First installation is expected in the second half of 1950 and several more will be made before the end of the year. These devices, when installed at airports, will give traffic controllers a complete picture of all airplanes within 30 miles, regardless of weather conditions. The equipment incorporates moving target indication which allows the operator to eliminate all objectional radar reflections due to stationary targets or severe rainstorms. A remoting system is also used which allows the radar set to be located as far as two miles from the control tower.

Government Business

The government market for electronics equipment in 1950 is estimated at \$300,000,000. General Electric is active in this field, with most of the equipment supplied of a classified nature.



N.R.I. ALUMNI NEWS

Harvey W. Morris President
F. Earl Oliver Vice Pres.
Alexander M. Remer Vice Pres.
Oliver B. Hill Vice Pres.
Claude Longstreet Vice Pres.
Louis L. Menne Executive Secretary



HARVEY W. MORRIS, 1950 PRESIDENT, NRI ALUMNI ASSOCIATION

Mr. Morris has been a member of the NRI Alumni Association for many years. He has served several terms as Chairman in Phila-Camden Chapter. He also has been a National Vice President for several years. Mr. Morris is a Television serviceman for a large distributor in Philadelphia.

Chapter Chatter



Here we are, making the rounds of our local NRI Alumni Chapters for the first time during the year of 1950. Although we are unable to give full reports of all of our local chapter activities, we are giving you some of the outstanding news. Activities so far this year have been very beneficial to local chapter members. We want to remind all NRI students and graduates who live in the vicinity of our local chapters that they are welcome to visit meetings, and to become associated with these local chapters. For further information, you should contact the secretary of the chapter which you wish to attend. Getting on with the report:

Detroit Chapter

We are proud to list our officers, elected recently, who will serve us during the year of 1950. They are: Chairman, Clarence McMasters; Assistant Chairman, Elwood Baumgarth; Secretary, Harry R. Stephens; Treasurer, F. Earl Oliver; and Librarian, Floyd Buehler. Our Financial Committee for the coming year consists of Steve Novosel, and Alex Nikora. We were also very pleased that our NRI Alumni Association has again chosen F. Earl Oliver to serve as a National Vice President. He has been one of our most faithful and helpful members for many years.

We are planning a social get together soon in the home of our newly elected President, Clarence McMasters, who lives in Amherstburg, Ontario, Canada. This should be a real treat for all of us.

Our "Service Forum" is a great success. Past-Chairman Bob Mains officiates at the blackboard, and F. Earl Oliver handles the test equipment. All members participate in the diagnosis of trouble.

We feel that the "Service Forum" is best adapted to the interests of our varied membership of students, graduates, part time and full time Radio and Television servicemen. A series of Television lectures are also in progress.

We are planning talks in the future on new types of test equipment and new types of merchandise.

We meet at 21 Henry Street, at Woodward, on the second and fourth Fridays of each month.

HARRY R. STEPHENS, Secretary,
5910 Grayton, Detroit 24, Mich.

Baltimore Chapter

Our new officers for the year of 1950 are: Chairman, Elmer Shue; Vice Chairman, J. C. Newton; Secretary, Thomas Kelly; Treasurer, F. J. Orban; Librarian, H. C. Voelkel; and Sergeant at

Arms, Thomas Clark. We feel that under the leadership of this very capable group of men we are going to make considerable progress during the coming year.

We have already changed our schedule of meeting nights so that we meet on each Tuesday night, with the exception of the first Tuesday in the month. We use the second and fourth Tuesdays of the month for our regular business meetings. The third (and the fifth, if there is one) Tuesday is used for a general get-together where members can discuss Radio and Television problems, and where beginners may ask our more experienced members about their Radio and Television problems.

We have nearly completed construction of our new test bench, and we hope soon to be able to purchase a complete line of test instruments for our chapter. With the addition of laboratory work, and perhaps refreshments occasionally, we expect to attract a larger membership. We also plan to purchase an FM-AM dynamic demonstrator.

We have enjoyed some excellent talks on Television by our able lecturer, Mr. Whitt. Other discussions during the past few weeks have largely involved planning our new test bench and laboratory work.

Remember that meetings are held regularly, each Tuesday night, except the first Tuesday in the month, at 745 West Baltimore Street, in Red Man's Hall.

THOMAS KELLY, Secretary,
1414 Mt. Royal Avenue,
Baltimore 17, Maryland.

New York Chapter

Our recent elections resulted in retaining our entire slate of officers for the coming year. This means that faithful Bert Wappler was reelected as Chairman; Alex Remer, Vice-Chairman; L. J. Kunert, Secretary-Treasurer; and Frank Zimmer, Assistant-Secretary-Treasurer. These officers meet regularly in the capacity of an Executive Committee in addition to attending our regular meetings.

We have enjoyed a very fine series of lectures by our capable member, Ralph H. Baer. Plans are afoot for a continuation of these lectures, espe-

cially on the Use of The Oscilloscope, by James Newbeck.

Meetings are held on the first and third Thursday of each month, at St. Mark's Community Center, 12 St. Mark's Place, between Second and Third Avenues, in New York City.

LOUIS J. KUNERT, Secretary,
539 Seaford Avenue,
Massapequa, New York.

Phila-Camden Chapter

We are enjoying the fellowship of several new members. They are: Fred Serganti, Henry Whelan, William J. Notte, Charles Frietag, Fred Mascavics, Raymond DuMont, Ernest Graeser, and Richard Stephan.

Our Vice Chairman, and also National President, Harvey Morris, is continuing his excellent instruction on Television theory and servicing techniques. Our meetings are picking up in tempo. We also plan to have representatives from a Radio manufacturing company and also from an

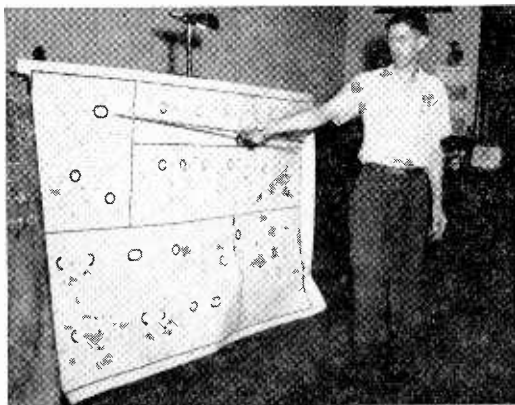

The National Alumni President, and Vice Chairman of the Philadelphia-Camden Chapter, delivering a lecture on Television Receiver Theory at a recent local chapter meeting. Members will be particularly interested in the large size schematic diagram shown in the photograph, which greatly aids in such lectures.

instrument company for future lectures. Members frequently bring in defective Radio receivers for diagnosis and repair.

Our meetings are on the second and fourth Mondays of each month, at 4510 Frankford Avenue, in Philadelphia.

ROBERT L. HONNEN, Secretary,
132 S. 58th Street,
Philadelphia 39, Penna.

Chicago Chapter

Our attention has centered on nominations and election of officers for the coming year. Election results were as follows: Harry Andresen, Chairman; Charles C. Mead, Secretary; Clark Adamson, Treasurer; Frank Yurek, Sergeant at Arms; and Louis Brodhage, Librarian. The past year has been one of progress for Chicago Chapter. We have more than doubled our membership, and greatly improved our meeting quarters. Many activities are scheduled for the coming year which will benefit all of our members.

At one of our recent meetings, Louis Brodhage delivered a splendid lecture on Superheterodyne Receiver Diagrams. One of our lectures scheduled for a coming meeting is "Characteristics of Diode Tubes and AVC Circuits." We also plan on movies.

We hope to go places during 1950, particularly in grooming our members for Television service. We hold regular meetings once a month, on the second Wednesday, in Room 1745, Merchandise Mart, 666 North Lake Shore Drive. Entrance is through the West door.

CHARLES C. MEAD, Secretary,
666 N. Lake Shore Drive, Rm. 227,
Chicago 11, Illinois.

— n r i —

Red Cross Blood Program. At the end of the first year and a half of its operation the Red Cross Blood program had 28 regional blood centers with 32 attached mobile units serving population areas totaling 40,000,000 persons. It is expected that 15 more regional centers will be established during the fiscal year. It is anticipated that by the end of the fiscal year blood collected from voluntary donors will have been distributed to nearly 2,000 hospitals.

General George C. Marshall, President of the American Red Cross, "now turns his wisdom, experience and great heart to guide the official humanitarian arm of the military forces and the nation's foremost disaster and welfare agency." —*New York Herald Tribune.*

American Red Cross Motor Service clocked up more than 9,000,000 miles last year on assignments for hospitalized servicemen, veterans, military personnel, and civilians, including crippled children and adults, transporting disaster workers and supplies, assisting in the Red Cross blood program and in other Red Cross work.

In 72 disasters affecting 32 states during the fiscal year ending June 30, 1949, 1,572 nurses served in Red Cross disaster relief operations. Duties included recruitment of nurses, staffing of emergency shelters and emergency medical stations, home visits to the ill and injured disaster victims, and supplementing hospital nursing staffs.



Here And There Among Alumni Members

Once again, through these columns, we thank our many members who sent us holiday cards, calendars and other tokens of friend-

ship. It is very pleasant to know we are remembered by many members in so many places.

— n r i —

Samuel S. Tucker, of Norfolk, Va., has real plans for the future. He now earns from \$25 to \$40 a week working spare time in an established Radio shop. All this extra money goes into a special bank account. Graduate Tucker plans to use his earnings to open a full time radio shop. This is the type of plan or dream that has started many a successful man on his way.

— n r i —

Graduate Bill J. Fair, Cave Springs, Ark., reports success on the 2nd class radiotelephone exam. He plans to take the exam for first class soon.

— n r i —

Charley Harvard of Joliet, Ill., is going into full time Radio servicing. His new shop is under construction and Charley can hardly wait to move in. He has outgrown his present small shop where he started on a spare time basis. That's the way to do it—build up gradually.

— n r i —

Graduate Chester C. Short, of Altoona, Florida, says he is doing especially well in Radio work, although, as he states, he's located way out in the sticks. Says success is due to NRI training, fair prices, and honest service.

— n r i —

Carl Samol of Coytesville, N. J., is assistant bench technician doing television alignment and trouble shooting for Bergen-Passaic Electronics, Inc. They service all makes of television receivers specializing in Dumont. Also important, Mr. Samol was married last June.

— n r i —

Alumnus Bert Salisbury, who owns his own servicing business in Vallejo, Calif., writes "We are in Television up to our ears. Sure glad of what I have learned from NRI."

— n r i —

B. R. Brink of Michigan City, Indiana, is an Engineer of established standing. Has a B.S. degree. Took NRI training to gain a working knowledge of electronics to aid him in fulfilling his duties as an engineer. Says he got what he wanted and finds Radio an interesting hobby.

— n r i —

Graduate Alfred J. Girard, Shrewsbury, Mass., has been a studio engineer for WAAB for some time. He is now with Television Station WNAC, Boston, Mass.

We were sorry to learn that Lou Kunert of New York Chapter lost his mother just before Christmas. She had not been well for some time. Our sympathies to Mr. Kunert and members of his family.

— n r i —

Here is a G.I. who is making good. Bart Hynes of Neshanic, N. J., is working for Western Union Telegraph Co., as a Radio maintenance man on their Micro-wave Radio Relay System. Good salary. We like to get these reports.

— n r i —

Richard P. Hatchett of Oklahoma City, Okla., is a Minister who works on radios as a hobby and a part time job. Graduated in 1941—still finds NRI a great help.

— n r i —

W. P. Searcy, Jr., of New Orleans, La., holds first class radiotelegraph, first class radiotelephone, and Class A amateur licenses. He has sailed for the past three years as a Chief Radio Officer, and is now employed by WDSU-TV as an Audio Engineer on the Microwave Relay Unit. Hams can find him on 75, 20, and 10 meters—his call letters are W5LV.

— n r i —

Edwin R. Hall of Yermo, Calif., is servicing Juke Boxes, Slot and Pin Ball machines. Judging from what Mr. Hall says, these people pay good salaries.

— n r i —

W9HDX is the new amateur call of Alumnus Ralph B. Stoll, Oshkosh, Wisconsin. Stoll says he gets a great deal of satisfaction and enjoyment from his hobby.

— n r i —

Willard Lay of Kingwood, W. Va., is doing nicely. His Radio servicing business has been his sole source of income for the past nine years. The population of his town is about 2,000, but he also draws a lot of business from out of town. Contented and happy is Willard Lay.

— n r i —

Graduate Delbert L. Breedlove is now attending a radio school in Tyler, Texas. He has his first-class radiotelephone license and amateur license, call letters W5QHD. He has also been in charge of one of the local stations in Tyler.

— n r i —

Graduate Karl I. Johnson paid a quick visit to NRI recently. He has been moving around the country so rapidly that we have trouble keeping up with him. A few months ago, he was employed by the RCA Service Co., in Chicago, and for a while represented the Chicago organization in New York City, then transferred back to Chicago. Now Johnson is in business for himself—the Export-Import business. Calls the firm the "International Nu-Products Co.," and is located here in Washington, D. C. Naturally new Radio and Electronic products are a specialty.

NATIONAL



NEWS

FROM N.R.I. TRAINING HEADQUARTERS

Vol. 14 February-March, 1950 No. 1

Published every other month in the interest of the students and Alumni Association of the

NATIONAL RADIO INSTITUTE
Washington 9 D. C.

The Official Organ of the N. R. I. Alumni Association.
Editorial and Business Office, 16th & You Sts., N. W.,
Washington 9. D. C.

L. L. MENNE, EDITOR
J. B. STRAUGHN, TECHNICAL EDITOR

NATIONAL RADIO NEWS accepts no paid advertising. Articles referring to products of manufacturers, wholesalers, etc., are included for readers' information only, and we assume no responsibility for these companies or their products.

Index

| Article | Page |
|--|------|
| Editorial | 2 |
| Building a Small Public Address System | 3 |
| The Social Impact of Television | 12 |
| Our Cover Photo | 13 |
| Interpretation of TV Test Patterns | 14 |
| How to Get Along With Others | 20 |
| Installing Three-Way Switches | 21 |
| NRI Alumni Association News | 28 |
| Chapter Chatter | 29 |
| Here and There Among Alumni Members | 31 |

Printed in U.S.A.

4

25236

Mr. Francis H. Ringado
611 17th St.
Denver 2, Colo.

For:

NATIONAL RADIO NEWS
16th & U Sts., N.W., Washington 9, D. C.

Sec. 36.44, P. L. & R.
U. S. POSTAGE
1c PAID
Washington, D. C.
Permit No. 7052