

NATIONAL RADIO NEWS



Capacity Relay
See Page 15

Aug-Sept.
1948

IN THIS ISSUE
Magnetic Recording
Building a Capacity Relay
Alumni Association News

VOL. 13
No. 4



Make Decisions

It is a very fine thing to have an "open mind." But it is a fine thing *ONLY* if you have the ability to make a *decision* after considering all sides of a question.

Failure to make a decision after reasonable consideration of all facts will quickly mark a man as being unfit for any position of responsibility.

So practice making clear cut, well thought out decisions.

Not all your decisions will be correct. No one is perfect. But if you get the habit of making decisions, experience will develop your judgment to a point where more and more of your decisions will be right.

J. E. SMITH, *President.*

Magnetic Recording

By WILLARD R. MOODY

NRI Consultant

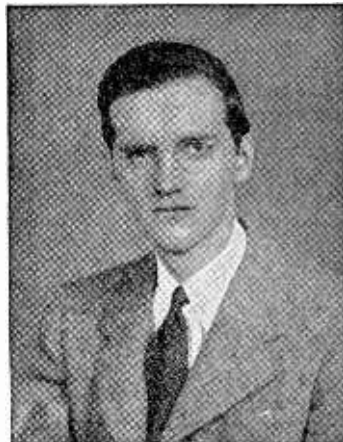

Willard R. Moody

MAGNETIC recording deals with the storage of signals, in a magnetic form, in a wire or tape having semi-permanent properties.

Probably, you will encounter a *wire* recorder at some time in servicing, or be called upon to explain the operation. The *tape* recorder uses similar principles but a tape instead of wire retains the recording. In either case, if desired, the original recording may be "wiped out" with no damage to the wire. The wire can be used over and over again, as many times as desired, to record new material and eliminate the old.

Programs as long as an hour in length can be put on the wire but most recordings will be considerably shorter. The commercial applications are numerous. In the home there is a definite entertainment value and also the asset of making it possible to record events of sentimental importance, birthday or wedding celebrations, etc.

The alert radio serviceman and dealer will be awake to the sales and servicing possibilities of magnetic recording equipment. This is being proved by public interest, the publication of numerous articles on magnetic recording and the production of the equipment, in quantity, by numerous manufacturers in the magnetic recording field.

The tape type may be used in a broadcasting station but does not seem to be as popular as the wire variety for use by the general public. Therefore, we'll be more concerned, here, with the wire version.

The magnetic recorder may be complete in itself, with mike, amplifier, and loudspeaker. Or, it may be a foundation unit designed to be fitted into a receiver circuit by a skilled engineer. Third, it may be a system designed to work with

a receiver, but completely engineered and capable of being installed by the average technician.

The foundation unit, alone, is not recommended for connection to an amplifier or receiver. The problems involved are too complex for the average technician. This foundation unit consists of the turntable, pickup head and motor assembly. It requires engineering into a complete receiver or amplifier circuit.

Students and graduates should purchase the Webster 78, or equivalent, for connection to a receiver or an amplifier—not a foundation unit alone.

The methods used in connecting this equipment will be described later on.

In using equipment of this kind it should be remembered that while the fidelity will be good and comparable to that obtained with an ordinary disk recorder of the home variety, it will not equal a high fidelity receiver or broadcast type disk recorder.

The operation of the equipment is far less critical than disk recording and there are no disk shavings to be brushed off.

A knowledge of fundamental electrical and radio principles is essential to the servicing of electronic equipment and the magnetic recorder particularly is no exception.

Basic ideas. The principle of magnetic recording was first invented by Valdemar Poulsen, a Danish scientist, in 1898 and the public first introduced to this new art in 1900 when Poulsen demonstrated his "Telegraphone" at the Paris Exposition of that year.

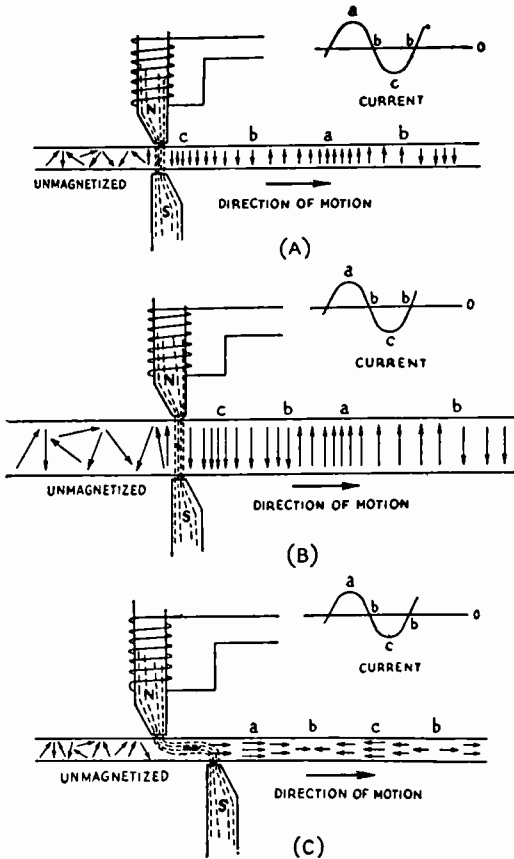

Fig. 1—Sketch illustrating three methods of magnetizing tape or wire. (A) perpendicular, (B) transverse and (C) longitudinal. In (A) the edge view of the tape (shown viewed from the top) is greatly exaggerated.

Courtesy of Webster, Chicago, Ill.

As its name implies, magnetic recording consists of impressing on a suitable medium a magnetic force which will leave a record on that medium. If the amplitude of this magnetic force varies in unison with the speech or music, there will be a similar variation in the recording medium. Poulson, and numerous investigators since his time, have generally used two fundamental types of mediums for magnetic recording—steel tape or steel wire.

When using a tape, any of three methods may be used for magnetic recording—perpendicular, transverse, or longitudinal. Simple diagrams, illustrating each of these three methods, are shown in Fig. 1.

In Fig. 1-A, the perpendicular method of magnetization is shown. It may be seen that the two magnetic poles are so placed in relation to the

tape that the tape is magnetized with lines perpendicular to both the flat faces of the tape and to its direction of motion. Since the flux in these poles is in phase with the current in the coils, the magnetizing force exerted on the tape is in phase with the current in the coils. If the amplitude of this current varies in unison with speech or music, the force exerted on the tape will vary likewise.

Since the steel tape is magnetic, the tiny molecular particles in the tape, represented by the arrows, will line up with this magnetizing force. Furthermore, as the tape passes out of the field between the poles a large number of these molecular particles will remain lined up. *It is this property of a magnetic material of retaining some of its magnetism after removal of the magnetizing force that makes magnetic recording possible.* The bunching of the arrows is used to indicate the relative strength of the magnetism left in the tape. The arrows are bunched close together at a spot which was passing the poles at the instant that the flux in the poles, and therefore a current in the coils, was passing through a maximum either above or below the zero axis. The arrows will be pointing downward at points along the tape where the current was below the zero axis, and in an upward direction at points where the current was above the zero axis. The letters A, B and C represent corresponding conditions for the current and the magnetism in the tape.

Transverse recording, shown in Fig. 1-B, is exactly the same as perpendicular recording except that the magnetizing force is exerted parallel to the flat face of the tape, although still perpendicular to the direction of motion.

Longitudinal recording, shown in Fig. 1-C, differs from the previous two methods in that the magnetizing force is directed parallel to the direction of motion. Thus the magnetic pattern is left as indicated. This is accomplished by displacing the pole slightly, as shown in the same sketch.

When using wire as a recording medium, longitudinal recording is the only successful method that can be used since otherwise the wire would have to be prevented from turning on its axis to prevent distortion when the record is being played back. For instance, if the wire turned through 180 degrees, arrows which should be pointing upward would be pointing downward. It is practically impossible to prevent wire from turning, although this is relatively simple with a flat tape.

Playback. After a record has been impressed upon the wire or tape, the process must be reversed to reproduce the record. That is, the magnetic impressions left on it must be used to produce electric impulses which can be amplified and eventually used to excite a loudspeaker. For-

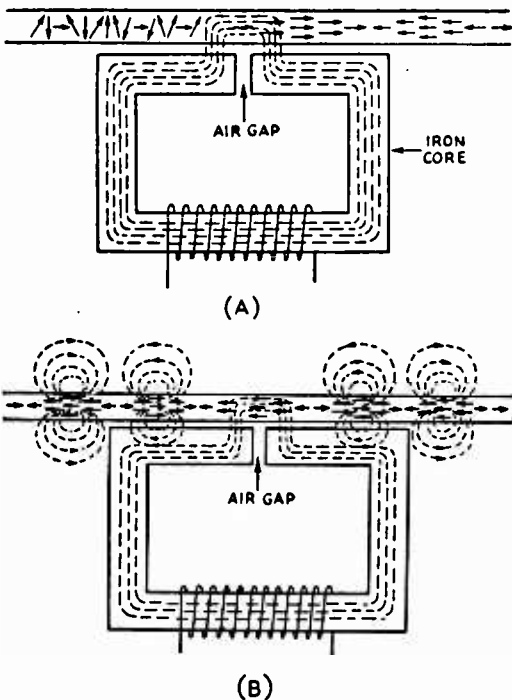

Fig. 2—Diagram showing magnetic paths, (A) in recording and (B) in playback.

Courtesy of Webster, Chicago, Ill.

tunately, in some cases, the same magnetic structure used for recording may also be used for playback. In the wire recorder, a type of recording head may be used which can be employed also for playback purposes. A diagram illustrating the principles of both recording and playback with this type of head is shown in Fig. 2. As may be seen from Fig. 2-A, during recording the current in the coils sets up a flux in the iron core which follows the core until it comes to the air gap. Magnetic flux likes to follow the path of least resistance, and since it is much easier for it to travel in iron or steel than in air, it travels around the air gap, through the steel wire and back into the core. Thus the wire is magnetized longitudinally.

During playback, the previously magnetized wire has flux lines, which are magnetic force lines, surrounding it as shown in Fig. 2-B. When molecular magnets of the tape are passing in the air gap, the flux lines find it much easier to travel over the longer path around through the iron core rather than through the air gap which offers greater reluctance to the passage of magnetic lines. Consequently, they pass through the core, as shown. These lines must necessarily "link"

the core and thus an electrical voltage is induced in the coil. The resulting voltage may then be amplified by means of an ordinary audio amplifier and used to excite a loudspeaker.

The basic recorder principle. Having explained the basic principle involved in magnetic recording, a complete system may now be shown. Fig. 3 shows a block diagram of such a system. During recording the switch is turned to the "record" position, marked R. The following sequence of events takes place. Sound impulses are picked up by the microphone, converted into electrical impulses, fed into the amplifier, amplified, fed into the recording head, converted into magnetic

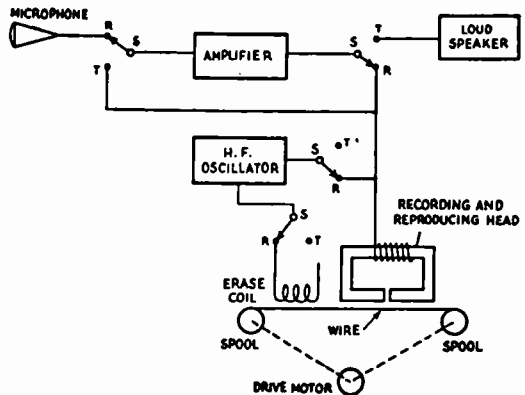

Fig. 3—Block diagram of a wire-recorder system.

Courtesy of Webster, Chicago, Ill.

impulses, and then impressed on the wire.

During playback, the switch is turned to the transcribed position, marked T. The magnetized wire passing through the head now sets up magnetic impulses in the cores. These are amplified by the same amplifier used for recording, and then fed to the loudspeaker which converts them into sound impulses.

During both the recording and playback processes the drive motor is used to turn the reels which unwind the wire from one reel, pass it through the head, and wind it up on the other reel.

Before the recording can be played back, it is necessary to rewind it on the first reel. Otherwise the speech or music would come out backwards which would sound very weird. This is the only processing necessary after recording.

The high frequency oscillator shown in Fig. 3 is connected to the recording head during recording. The purpose of this oscillator is to reduce distortion which would otherwise be present. The actual functioning of this oscillator is beyond the scope of this discussion, but by using it a much

Tube Voltages								
Tube	Pin	Switch In Record Pos.	Switch In Playback Pos.					
6X5	2	3.1	3.1	R-1	Carbon Resistor 1000 Ohms ½ Watt			
	3	340	335	R-2	Carbon Resistor 100000 Ohms ½ Watt			
	5	340	335	R-3	Carbon Resistor 47000 Ohms ½ Watt			
	7	3.1	3.1	R-5, R-7	Carbon Resistor 220000 Ohms ½ Watt			
	8	370	360	R-6	Carbon Resistor 39000 Ohms ½ Watt			
6V6	2	3.1	3.1	R-8	Carbon Resistor 4.7 Megohms ½ Watt			
	3	320	300	R-9, R-12	Carbon Resistor 68000 Ohms ½ Watt			
	4	320	300	R-10, R-13	Carbon Resistor 820 Ohms ½ Watt			
	5	-.43	...	R-11	Carbon Resistor 270 Ohms 1 Watt			
	7	3.1	3.1	R-14	Carbon Control 1 Megohm			
6J5	8	11.0	13.5	R-15	Carbon Control 50000 Ohms			
	2	3.1	3.1	R-16	Carbon Resistor 1 Megohm±5% ½ Watt			
	3	150	135	R-17	Carbon Resistor 270000 Ohms ½ Watt			
	7	3.1	3.1	R-18	Carbon Resistor 220000 Ohms±5% ½ Watt			
	8	4.2	4.2	R-19	Carbon Resistor 22000 Ohms ½ Watt			
6SJ7	2	3.1	3.1	C-1	Paper Condenser .001 Mfd 600 Volts			
	5	.25	.25	C-2	Paper Condenser .02 Mfd 400 Volts			
	6	14	13	C-3	Paper Condenser 1.0 Mfd 200 Volts			
	7	3.1	3.1	C-4	Paper Condenser .0001 Mfd 600 Volts			
	8	75-150	65-150	C-5, C-8, C-11	Paper Condenser .05 Mfd 400 Volts			
NOTES: 1. All voltages measured with line voltage of 117 volts at 60 cycles with volume control in full counter-clockwise and tone control in full clockwise positions. 2. All voltages shown are measured to ground (chassis). 3. Voltages shown in <i>ITALICS</i> are A.C. Voltages, all others are D.C. 4. A.C. voltages are measured with a rectifier type instrument the sensitivity of which is at least 1000 ohms per volt. 5. D.C. Voltages are measured with a D.C. type Vacuum Tube voltmeter. 6. Voltages should be as shown plus or minus 10 percent.			C-6	Paper Condenser .0001 Mfd 600 Volts				
			C-7	Mica Condenser .002 Mfd 600 Volts				
			C-9	Paper Condenser .01 Mfd 400 Volts				
			C-10	Shielded Condenser .01 Mfd 100 Volts				
			C-12	Paper Condenser .002 Mfd 600 Volts				
			C-13	Paper Condenser .5 Mfd 400 Volts				
			EC-1	Electrolytic Condenser -2 Section- 25 Mfd 450 Volts				
				15 Mfd 350 Volts				
			EC-2	Electrolytic Condenser -1 Section- 10 Mfd 25 Volts				
			EC-3	Electrolytic Condenser -3 Section- 15 Mfd 350 Volts				
				15 Mfd 250 Volts				
				40 Mfd 24 Volts				
						NOTE: All Resistor Values are ± 10% unless otherwise specified.		

Figure 6. Webster Model 80 Wire Recorder Parts List.

Courtesy of Webster, Chicago, Ill.

The wire used is only 1/1000 of an inch in diameter, comparable to a human hair. Because of its small size, approximately two miles (11,500 feet) can be wound on a spool only 3¼" in diameter and 1¼" thick. This length of wire is satisfactory for a recording of speech lasting a little over an hour. This illustrates one advantage of wire over tape, and that a given length of recording will occupy less volume than tape. Another advantage is that the wire may easily be cut in sections spliced in for "dubbing-in" if desired. The splicing is accomplished simply by annealing the ends to be spliced with a match or lighted cigarette and tying a simple knot.

We shall examine typical commercial designs, such as the Webster 80 Wire Recorder shown in Fig. 4.

The circuit diagram of the Webster 80 is shown in Fig. 5 and parts list in Fig. 6. The operating voltages, useful servicing data, are also shown in Fig. 6.

Basically, this is a circuit of a high gain, low power amplifier. The circuit also makes provision for the use of the 6V6 as a supersonic oscillator to "erase" recorded sound stored in the wire.

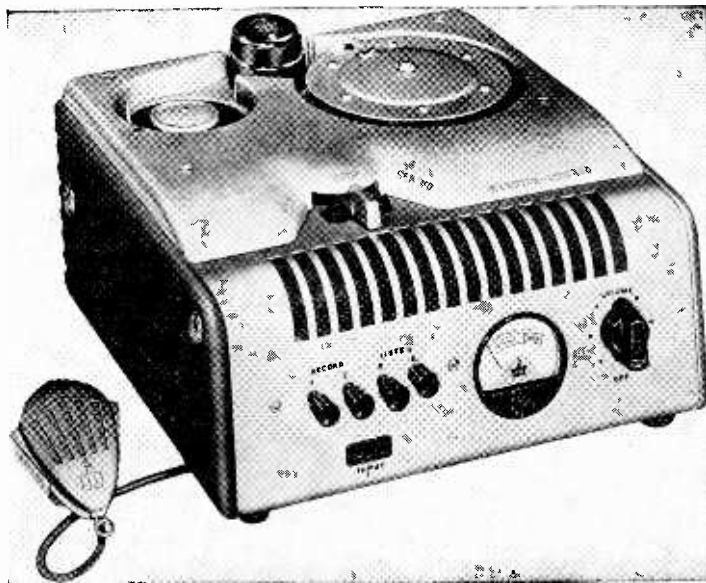

Courtesy of Webster, Chicago, Ill.

Figure 7. The Webster Model 78 Wire Recorder.

control in series with C-8.

If a record player is connected to 1-3 of the input jack, the 6SJ7 pre-amplifier is eliminated since its high gain is unnecessary with a signal source of that type. The output of a receiver's diode detector could also, if desired, be fed into 1-3.

On "listen," the signal voltage developed by the magnetic head appears between 2 and ground and is applied through the connecting lead (white) and R-9, C-1, to C-6. This voltage is then applied to the input of the 6SJ7 through C-10 and is amplified as described previously. The signal is reproduced by the loudspeaker or may be fed into the input of an audio amplifier by means of the output jack at the lower right of the diagram.

Servicing. The servicing of the equipment will be similar to that required for the maintenance of any standard low power amplifier or the audio system of a modern radio receiver. The complete factory manual, of course, should be consulted if the repairs needed are serious and extensive in nature. A copy may be obtained from your radio distributor or directly from Webster—Chicago, 5610 Bloomington Avenue, Chicago, 39, Illinois.

Another instrument in which students and graduates have shown a great deal of interest is the Webster 78 Wire Recorder illustrated in Fig. 7. The schematic diagram is shown in Fig. 8.

Four tubes are used in the recorder, 6AT6 pre-amplifier, 6AU6 voltage amplifier, 6AR5 high frequency audio oscillator and, in the power supply, a 6X4 full-wave rectifier. A detailed analysis of the circuit is unnecessary but we shall study the circuit later. Let's see how this equipment is used.

It is important that the operating instructions be read carefully before it is attempted to operate the equipment. This is true whether you are an experienced sound technician or a beginner. These instructions are furnished with the recorder.

To Make A Recording

1. Push the "Record 1" button on the recorder. (Use button "Record 2" to record direct from the

The mike is a high impedance crystal type and is plugged into the input jack on the lower left of the control panel, near the volume control.

This jack assembly has contacts marked 1, 2, 3, on the diagram in Fig. 5. The number 1 contact is grounded and so is the shielding of the mike cable, for stability and freedom from noise and oscillation. The low level mike signal voltage is across terminals 1-2 and is applied through the switch to C-10 and the input of the 6SJ7.

This tube then amplifies the signal which is fed through C-2 and the volume control, R-14, to the 6J5 grid. This tube further amplifies the signal and feeds it through C-3 and the switch to R-13 and the grid of the 6V6.

The switch, however, is shown in the "erase" position and the 6V6 is functioning as an oscillator. This position would be changed to "listen" for the 6V6 then drives the loudspeaker through the output transformer and switch 32P041.

On "record" the signal is applied through switch 32P040 to C-6 and the 6J5 signal voltage is applied through R-9, C-1 to terminal 2 of the record-playback head. The presence of C-6 results in a certain amount of de-emphasis of the "highs" to compensate for the recording characteristic of the instrument, including mike and recording head. However, control over the tone can be exercised by R-15 which is a simple shunt type

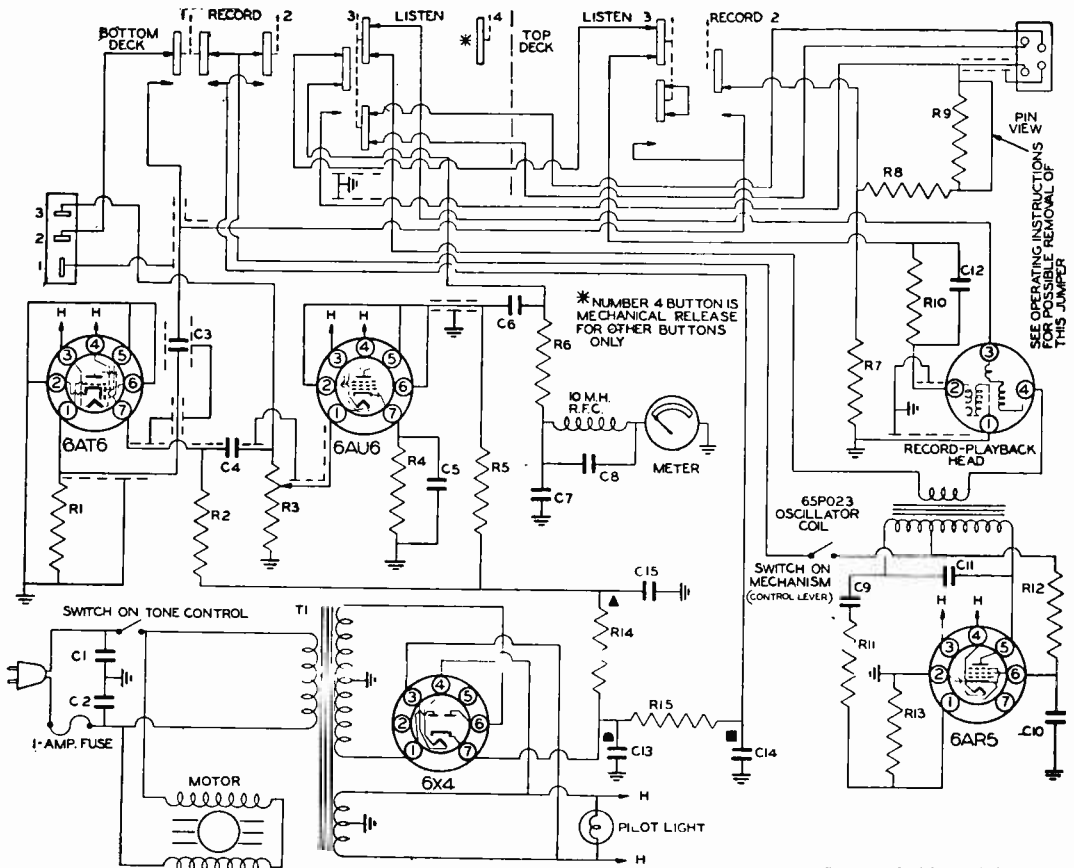

SEE OPERATING INSTRUCTIONS FOR POSSIBLE REMOVAL OF THIS JUMPER

Fig. 8. Schematic and Parts List of Webster Model 78 Wire Recorder.

Courtesy of Webster, Chicago, Ill.

PARTS LIST

R1	Carbon Resistor	4.7 Megohms	1/2 Watt	C1	Molded Condenser	.05 Mfd.	400 Volts
R2	Carbon Resistor	470,000 Ohms	1/2 Watt	C2	Molded Condenser	.05 Mfd.	400 Volts
R3	Carbon Resistor	1 Megohm		C3	Shielded Condenser	.01 Mfd.	
R4	Carbon Resistor	1,000 Ohms	1/2 Watt	C4	Paper Condenser	.02 Mfd.	400 Volts
R5	Carbon Resistor	39,000 Ohms	1/2 Watt	C5	Electrolytic Condenser	10. Mfd.	25 Volts
R6	Carbon Resistor	16,000 Ohms $\pm 5\%$	1/2 Watt	C6	Paper Condenser	.5 Mfd.	400 Volts
R7	Carbon Resistor	220,000 Ohms	1/2 Watt	C7	Paper Condenser	.002 Mfd.	600 Volts
R8	Carbon Resistor	4.7 Megohms	1/2 Watt	C8	Paper Condenser	.002 Mfd.	600 Volts
R9	Carbon Resistor	4.7 Megohms	1/2 Watt	C9	Paper Condenser	.002 Mfd.	600 Volts
R10	Carbon Resistor	68,000 Ohms	1/2 Watt	C10	Paper Condenser	.002 Mfd.	600 Volts
R11	Carbon Resistor	3,900 Ohms	1/2 Watt	C11	Molded Condenser	.002 Mfd.	600 Volts $\pm 20\%$
R12	Carbon Resistor	22,000 Ohms	1 Watt	C12	Paper Condenser	.001 Mfd.	600 Volts
R13	Carbon Resistor	68,000 Ohms	1/2 Watt				
R14	Carbon Resistor	15,000 Ohms	1/2 Watt				
R15	Carbon Resistor	1,000 Ohms	2 Watt				
All resistor values are $\pm 10\%$ unless otherwise specified.							
C13	Electrolytic Condenser	20. Mfd.	450 Volts				
C14	Electrolytic Condenser	10. Mfd.	450 Volts				
C15	Electrolytic Condenser	10. Mfd.	350 Volts				

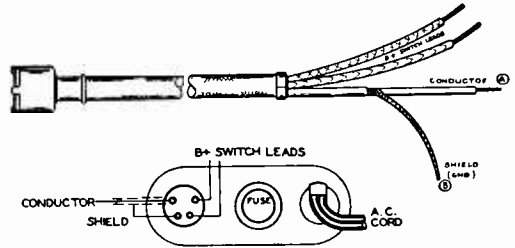
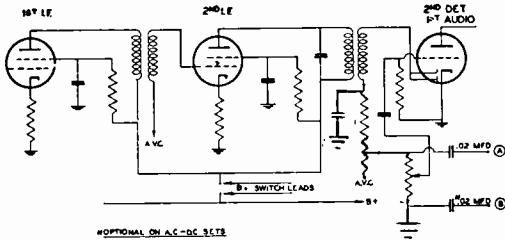

Figure 9

radio after the connections described later have been made).

2. Move the "Run-Rewind" control lever to the "run" position.
3. Advance the volume control for proper recording level and make the recording. (Additional information on this will be given later.)
4. Move the control lever to "stop" at the end of the recording.
5. Move the control lever to "rewind." At the end of the rewind cycle, quickly move the control lever to "stop."

To Play Back A Recording

1. Connect the Model 78 to your radio receiver or amplifier as shown in Fig. 9.
2. Raise the head as for recording.
3. Route the wire.
4. Push the "listen 3" button.
5. Advance the recorder volume control and the radio volume control for enjoyable listening.
6. Adjust the radio tone control to suit your preference.
7. Move the control lever to "stop" at the end of the play back.
8. Move the control lever to "rewind." At the end of the rewind cycle, quickly move the control lever to "stop."

We have studied the functional operation of the equipment, but before it can be used it must be connected to an audio amplifier. The necessary connection arrangements will now be discussed.

Connections

A four foot cable is provided for connecting the Model 78 to a radio receiver. It is recommended that this cord be left intact, if possible, in order

to make future rearrangements of the wire recorder and receiver possible without undue inconvenience.

Connect the cord to the receiver as indicated in Fig. 9. The circuit shown does not describe any particular radio receiver but is typical of modern circuits. The .02-mfd. condenser marked with an asterisk is usually necessary on a.c.-d.c. receivers.

Some radio receivers deliver a stronger audio signal to the audio amplifier input than others. Failure to compensate for this would overload the 6AT6 input of the wire recorder and cause distortion which cannot be detected by the volume level indicator.

Therefore, after the preliminary installation, make a test recording. When recording, the volume level needle should not reach the red portion of the dial on the loud sounds until the volume control is advanced to at least "one o'clock," considering the volume control pointer as the hour hand of a clock. If distortion is present during play-back, or if a lower volume control setting is necessary to avoid "over recording," do the following:

1. Remove the cover from the recorder mechanism by removing the two mounting screws in each side.
2. Cut the jumper which is connected across the 4.7 megohm resistor of the input voltage bleeder network. This jumper is shown by means of an arrow in Fig. 10. This will double the value of the dropping resistor and compensate for the stronger signal.

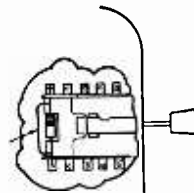

Figure 10

3. Make another test recording to be certain that distortion is not present.

Although the circuit diagrams fully explain the few connections necessary to install the Model 78, the connections should be made by a qualified service technician.

Connecting to a Public Address type Amplifier and Speaker

Solder one end of a length of microphone cable to the terminals of the extra female cinch plug furnished with the equipment. Connect the other end of the cable to the phono input of the public address amplifier. Ignore the other two terminals of the output plug.

The Controls and What they Do

The Control Lever. This lever shifts the motor and associated drive wheels to engage the take-up spool drum or the supply spool drum, whichever is desired. This winds the wire from one spool to the other across the groove of the recording head. At the same time the recording head moves up and down to wind the wire evenly on the spool or drum. The wire runs at a speed of approximately two feet per second in the "run" position and about seven times this speed in the "rewind" position. Either the forward or rewind cycle may be interrupted at any time by moving the control lever to the "stop" position.

This lever also actuates a set of brakes to prevent the wire from running loosely or too fast and stalling. For this reason it is not advisable to attempt to add a foot pedal switch or other means of remote control.

Input Socket. This socket has three contacts. No. 1—The vertical contact in Fig. 8—is the common ground connection. No. 2 or the middle horizontal contact is for microphone input. It connects the microphone to the grid of the 6AT6 pre-amplifier for low level inputs. No. 3—top horizontal contact—connects a crystal phono pickup to the first grid of the 6AU6 inter-stage amplifier for high level inputs.

The Volume Level Indicator. Turn the volume control to the right until the meter just reaches the red or "overload" part of the scale on the loud sounds. Do not increase the volume during low level parts of a recording even though the meter needle temporarily drops to the small red part of the scale or the full dynamic range of the original program will not be reproduced. Most of the average recording will be made with the meter needle near the center of the green or normal area.

The Push Button Controls. When the button marked "Record 1" is depressed, terminals 1 and 2 of the input socket are connected across the

input of the 6AT6 pre-amplifier tube. Any microphone with an output of —50 db or better may be used across these terminals. This push button may be considered as "record-microphone."

Push button "Record 2" connects the shielded lead of the four wire cord across the input voltage divider network of the recorder. Depressing this button automatically connects the radio receiver or the pickup of a radio-phonograph combination to the input of the wire recorder when all other connections have been made. This button may be considered as "Record-Radio" or as "Record-Phono" in the case of a radio-phono combination.

Button "Listen 3" connects the output of the recorder to the output plug. The output voltage may be fed to the audio amplifier of a radio receiver through the shielded cord or to the phono input of a public address type amplifier and speaker by means of the extra female cinch plug and a length of microphone cable. If the cord assembly is attached to a radio receiver, the B+ circuit is opened and the plate voltage is removed from the i.f. stages to eliminate any interference from a radio signal. This button may be considered as "Play Back."

Button "Listen 4" is for normal radio receiver operation. Depressing it removes the recorder circuit entirely from the radio or amplifier circuit.

No special precautions are necessary. Pushing the wrong button cannot damage the recorder, the radio or the external amplifier and speaker. However, only one button should be pushed at a time.

Operating Tips

Recording on New Spool of Wire. Before making a recording on a new spool of wire it is advisable to run the entire spool through the recorder once and rewind it. This is advisable for two reasons. First, the wire will then be wound on the spool in direct relation to the rise and fall of the recording head. This is called phasing. Second, the rewound spool will be somewhat more loosely wound and the free end may "tuck in" more securely. This operation may be performed with the "Record-Listen" switch in either position.

Caution: Do not attempt to use a one-hour spool of wire until you are experienced in the use of the fifteen minute and thirty minute spools and the controls of your recorder.

Before using a one-hour spool of wire be sure that:

1. The groove of the recording head is clean. Use carbon tetrachloride and a brush or cloth to clean it.

2. The brakes are properly adjusted. The wire should not run or wind loosely especially during rewind.

3. Wire winds evenly on the supply spool during rewind.

Do not record more than sixty minutes on any one spool. Save any excess wire on a spool for future use and rewind only the actual recording. Rewinding more than sixty-one minutes of wire on a single spool may cause the excess to spill over and part of the recording may be lost.

Microphone technique. The ability to get the best results with a microphone improves with practice. The microphone is held far enough from the mouth to permit the volume control to be at least "one o'clock" without over-recording when recording a normal speaking voice as in public address work.

Some people pronounce "b's" and "p's" with an explosive puff which overloads the microphone; others speak sharp, clear sibilants which are over-accentuated when the recording is played back. In such cases, or in recording whistling, the microphone should be held sideways so that it is at right angles to the mouth.

Since there are many variations in individual speech, it is advisable to make a few practice recordings to discover the best microphone distance and volume setting for perfect recording. The usual tendency is to talk too loudly and too close to the microphone.

For recording musical instruments or singing where the microphone may be several feet from the source of sound, it should be remembered that room echoes will seriously affect the quality of the recording. This is important. That is why sound studios and radio broadcast studios are specially treated to keep such echoes from reaching the microphone.

The MN-35 microphone supplied with the recorder has excellent frequency characteristics and high sensitivity. Its output is rated at -52 db.

When recording groups, non-directional characteristics will result from placing the microphone on its back on a soft pad (to absorb unwanted jars and vibrations). Rather large groups can be recorded successfully.

When recording speeches or programs in an auditorium equipped with a good public address system, better results and convenient recording conditions may often be obtained by placing the microphone in front of one of the loudspeakers instead of trying to record directly at the speakers stand.

Most problems associated with microphone placement and microphone technique are those encountered by the average public address technician. Each installation is different. Only experience will enable you to quickly analyze a new set of conditions and correctly place the microphone. However, you can learn in your own home the most frequently encountered recording conditions. Special problems can best be solved on the spot.

The volume level indicator is as useful in making a good recording as an exposure meter in taking good pictures. Use it carefully as explained previously.

Important. Clean the Recording Head. Dirt and grime gradually accumulate in the groove of the recording head, causing the wire to stick and produce "wild" and spotty recordings and play back. Clean the groove from time to time with carbon tetrachloride and a folded or small stiff brush. While the cloth is saturated with carbon tet, remove the top from the mechanism and clean the brake drums and idler wheels.

Erasing a Recording. As the wire passes across the recording head with the control lever set to "Run" and either of the "Record" buttons depressed, the wires demagnetize by the action of the erase coil just before it reaches the recording coil, both coils being incorporated in the dual purpose head. Therefore, recording is always done on demagnetized wire.

If the microphone or other signal source is not plugged in, or if the volume control is turned off, the wire will be erased and no recording will remain. This feature of magnetic recording makes it possible to erase a word or phrase in a voice recording, and, if desired, insert a new word or phrase in its place.

A wire may be used for thousands of successive recordings or a complete spool may be erased without putting any other sound on the wire.

It is sometimes possible, by turning the volume control too far to the right, to magnetize the wire to such a degree that the recording cannot be erased by normal means. Recordings made under these circumstances may not be clear but would be distorted due to the over-magnetization of the wire. The wire conditioner No. WC286, available from a dealer handling the Webster products, will erase any unwanted previous recording.

When Wire Runs Off Spool. Try to avoid running the wire completely off the supply spool on to the drum. Stop the recording or play back with a few turns of wire remaining on the supply spool, thereby eliminating the necessity of re-threading the wire on the spool. If the wire does run off the spool, re-thread the wire onto the

spool, with the label side up, wrapping a few turns of wire around the loose end as though you were winding the cord around a top.

To Avoid Spilled Wire. Do not disconnect the power cord from the Model 78 or from a wall socket when the unit is in operation. Avoid placing the power cord where it may be accidentally disconnected. If the wire runs entirely off the take-up drum onto the supply spool, move the complete "control lever" to the "stop" position immediately.

Loose brakes, especially on the take-up drum during the rewind cycle, will permit the wire to run loosely and possibly spill or snarl. The brakes should be tight enough to keep the wire taut, but not tight enough to slow up the speed of the rewind.

Splicing wire. If it is desired to remove or insert a section for editing reasons, or if the wire is accidentally broken, the ends may be spliced by tying them together with a simple knot. Pull the knot tight and cut off the loose ends close to the splice. The knot will pull across the recorder head without catching.

Typical commercial wire recorder designs have been shown and discussed and while others of different makes may differ somewhat in the details, the basic principles will remain the same and there often will be a similarity between circuits of different recorders just as there is a similarity in the basic circuits used in different radio receivers.

Magnetic recording is something that bids fair to become increasingly popular in the succeeding years and you should become thoroughly acquainted with it.

— n r i —

A man's real limitations are not the things he wants to do, but cannot; they are the things he ought to do, but does not.

—The Kodak Magazine.

— n r i —

Suggestions on Buying Test Equipment

Letters from Students and Graduates often tell us of buying test equipment that is either too inferior to be useful, or the other extreme, more elaborate and expensive than is necessary. Write to L. L. Menne, Director of the NRI Supply Division, for free information and impartial advice on the instrument you are considering, or for general test equipment information. Free Test Equipment Data Sheets are available upon request.

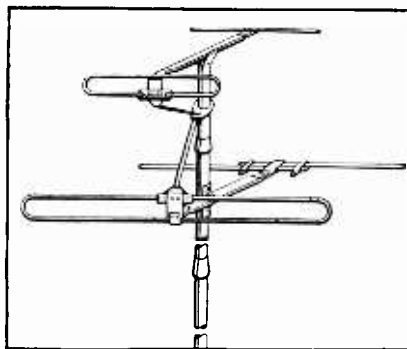

High and Low Band Television Antenna

To provide proper reception of all thirteen television channels, the Taco Cat No. 465 High and Low Band Television Antenna is announced by Technical Appliance Corporation of Sherburne, New York.

This latest television antenna comprises a low-frequency folded dipole and reflector assembly surmounted by a smaller high-frequency folded dipole and reflector assembly, both being mounted on a sectional aluminum tubular mast and connected together by a quarter-wave connecting link. The combined rig features (1) Ease and simplicity of assembly; (2) Rigidity and practical mounting features; (3) A matching network insuring top performance under all conditions; and (4) a construction permitting the orientation of the high and the low band antenna independent of each other. While the first three features are found in every Taco antenna, the fourth is unusual yet is highly desirable with the growing number of television transmitters. Since reflections or "ghosts" may vary with frequency, location and surroundings, different orientation may be necessary even where the transmitting antennae are located adjacent to each other.

As is the case with all Taco television and FM antennae, this Type 465 comes in a compact carton, ready to be assembled by any one using just pliers and screwdriver for tools.

— n r i —

Don't

Don't grumble, don't bluster,
Don't dream, and don't shirk.
Don't think of your worries;
Just think of your work.
The worries will vanish.
The work will be done.
No man sees his shadow
Who faces the sun.

SUCCESSFUL SPARE-TIME BUSINESS

Uses NRI Professional Test Instruments

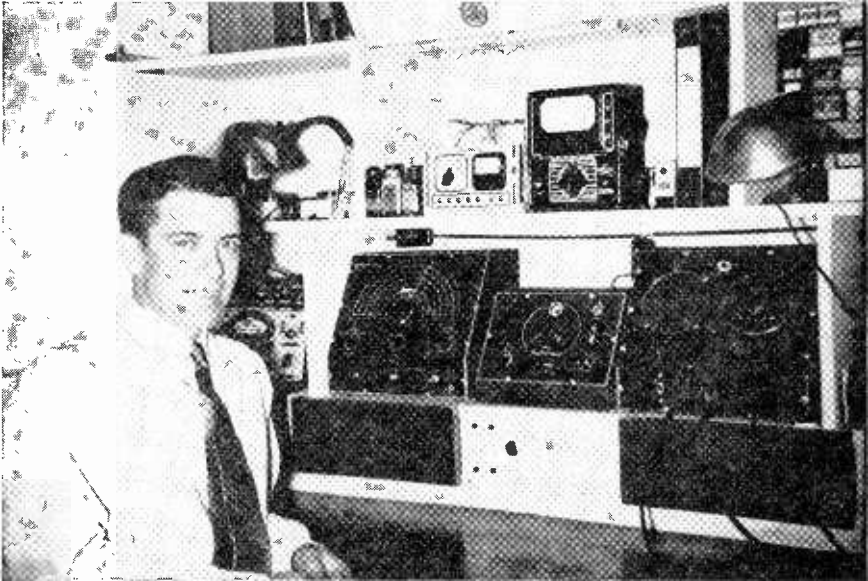

The above photograph shows Graduate Rene C. Hequet and his Radio bench. Notice his NRI Tester and Model 44 NRI Professional Volt-Ohm-Mil-Ammeter on the top shelf. On the lower shelf, from left to right, is the Model 88 NRI Professional Signal Generator, the Model 112 NRI Professional Resistor-Condenser Tester, and the Model 33 NRI Professional Signal Tracer.

Dear Mr. Smith:

Thanks to the NRI and its staff for the clear, interesting and sure way they teach Radio.

Please note the complete NRI test instruments, including the NRI tester furnished with your lessons. The test equipment is fine and good looking. I also built the test bench myself, from plans you sent me.

I'm for the NRI all the way through. Am doing

spare-time repairing and get more work than I can handle, and I haven't done any advertising. One satisfied customer just tells another about the good work he got, and it just keeps on coming.

I average \$10 per week easy. Thanks a million.

Very truly yours,

RENE C. HEQUET,
Kankakee, Illinois.

Building and Using a Hand Capacity Relay

By LOUIS E. GARNER, JR.

NRI Consultant



Louis E. Garner, Jr.

OUR COVER PHOTO: A practical application of the capacity relay attracted considerable attention when installed in a show window of Goodman's Electrical Store, Silver Spring, Maryland.

EDITOR'S NOTE: We wish to thank NRI Graduate James Boyett of Greenwood, Mississippi for suggesting a basic circuit around which the unit described in this article was designed.

While the device described in the following article is comparatively simple, it is recommended that only graduates and more advanced students undertake its construction and use. The basic circuit, of course, is straightforward and layout is not particularly critical—however, if trouble is encountered, correction of the defect may lead to a "cut-and-try" method which is likely to prove discouraging to a beginner.

RADIO servicemen, experimenters, and students, often wish to work with electronic devices other than conventional radio receivers and audio amplifiers. Some of the other types of electronic devices which can be easily built by the average service technician also have valuable practical applications. One of the most interesting is the Capacity Operated Relay.

Capacity relays, as they are more often called, find wide application in industry as burglar alarm devices and as control devices for some types of industrial processes. Considerable development work has been carried out on capacity relays and there are some commercial units available which employ as many tubes as a large radio receiver and with circuits even more complex.

The unit to be described in this article, however, is fairly simple, using only two tubes, and with a limited sensitivity. By employing stages of amplification and additional tubes, it is possible to make capacity relays so sensitive that a person approaching within several feet of the thin wire will cause the unit to operate. Naturally, such extremely sensitive commercial units as these are quite expensive and use fairly complex circuits.

What is a capacity relay?

Exactly what the name implies—it is an electronic device, with an ordinary relay incorporated as part of the device. The entire unit is designed to operate the relay, closing or opening a switch, when a change in capacity is obtained. A change in capacity might be caused by a body approaching a wire or metal plate.

Since it is not necessary to actually touch or trip a switch, to break a light beam, or actually come in contact with any connection, such a device has wide application—the application being limited primarily by the sensitivity of the particular unit being used and by the imagination of the engineer or technician using the unit.

The principle of operation of a capacity relay is quite simple. Basically, the unit consists of nothing more than an oscillator, relay, and power supply. The oscillator is so designed that a change in capacity to ground will cause the in-

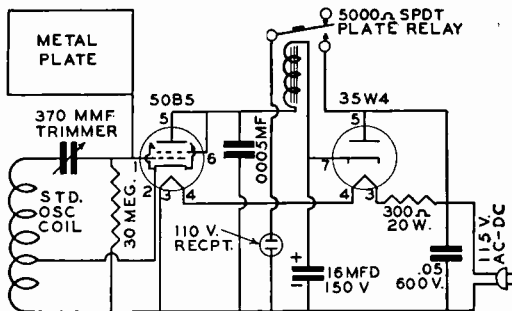

Fig. 1. Schematic of capacity relay.

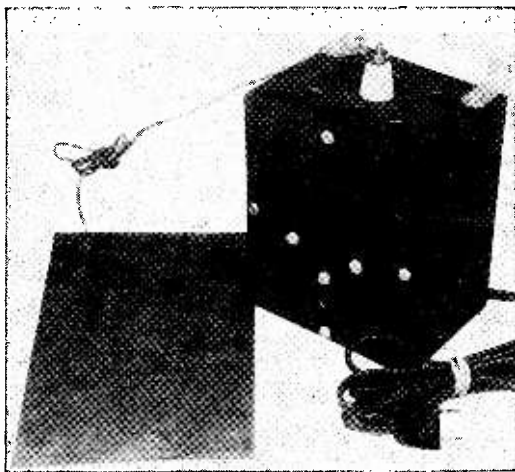

Fig. 2. The complete unit.

tensity of oscillation to change (and usually the frequency), thus causing the current in the plate circuit of the oscillator tube to either increase or decrease. By using a sensitive relay and adjusting it carefully, this increase or decrease in plate current can be used to close (or open) the relay, closing contacts and supplying current to some other circuit.

Almost any electrically operated device can be in the controlled circuit—electric lamps, alarm bells, an electric train for display (or any other electrically operated display piece), etc. The device described in this article is designed primarily for the operation of a store window display.

Description of Capacity Relay

The schematic diagram for a capacity operated relay is given in Fig. 1. Let us analyze, briefly, its operation.

First, we note that two tubes are used—a beam power amplifier tube and a half-wave rectifier tube. The filaments are connected in series and a filament dropping resistor is used. A conventional half-wave rectifier circuit is used so that the unit can be operated on either an a.c. or d.c. line. The beam power tube is triode connected, the screen grid and plate being connected together. As can be seen by referring to the schematic diagram, the tube is connected as a conventional oscillator. A sensitive relay is in the plate circuit of the oscillator tube. This relay can be adjusted to just open under normal conditions and to close when a change in oscillation intensity occurs. When the relay closes, power can be drawn from the receptacle shown.

The intensity of oscillation is determined by the adjustment of the 370 mmf. trimmer condenser and the capacity between the metal plate and earth. That is, the relationship of these two capacities forms a capacity voltage divider so that the actual a.c. voltage applied to the grid depends on the proportional relationship between these two capacities. By changing the capacity between the metal plate and ground—by placing your hand near the metal plate—a change in intensity of oscillation is obtained so the relay will operate. When the added capacity is removed, the oscillator functions normally and the relay opens.

The operating frequency of this particular unit is 2800 kc.—but the operating frequency is not critical and will depend, to a large extent, upon the exact type of oscillator coil used, upon the distributed capacities in the wiring, etc.

A somewhat larger than normal line dropping resistor is used to operate the tube filaments at less than normal voltage. This provides increased tube life which is desirable in any electronic device designed for continuous use.

Construction of the Capacity Relay

Standard parts are used throughout. Layout is not particularly critical, although too much change in distributed capacities may require a certain amount of experimentation to obtain optimum operation. If, in the particular model you build, you find that operation is not obtained, experiment with the value of the 30 megohm grid resistor, and try different size trimmer condensers in the grid circuit of the oscillator tube.

The entire unit has been built in a standard 3 x 4 x 5 metal box. The lead to the capacity plate is brought out from the box through a stand-off feed-through insulator. A standard receptacle has been placed on the side of the box for plugging in the control device. Ventilation holes have been provided in the box to keep the parts cool. The trimmer condenser is adjusted through a small hole in the front of the box.

Mounting brackets have been provided in the experimental model for easy mounting below a store window.

The complete unit, ready for installation, is illustrated in Fig. 2.

Although the wiring seems somewhat difficult due to the compact construction as illustrated in Fig. 3, such is not the case. Actually, the chassis plate is mounted to the front panel which is removable as shown in Fig. 4, allowing easy access to the various parts so that wiring is comparatively simple. All parts are mounted on the small sub-chassis visible in Fig. 4 except the relay itself and the plug-in receptacle which are mounted to the shell of the metal box.

The total cost of parts for building the unit, at net prices, should not exceed \$8 to \$10 (not including labor). All parts are standard but it is recommended that the same type relay be used as was used in the original model.

For your convenience, a detailed list of parts follows. Where possible, the original manufacturer's type number is also given.

Feed-through insulator.

Cabinet—Bud type CU-728, 3 x 4 x 5 standard metal box.

Relay—Potter and Brumfield type LP5, SPDT, 5000 ohm coil.

Receptacle (for line cord) Amphenol type 61-F. Two miniature sockets.

Oscillator coil.

370 mmf. trimmer condenser.

16 mfd., 150 volt tubular electrolytic condenser.

300 ohm, 20 watt wire wound resistor.

30 megohm resistor (three 10 megohm $\frac{1}{2}$ watt resistors in series).

.0005 mfd., 600 volt paper condenser.

.05 mfd. 600 volt paper condenser.

35W4 miniature tube.

50B5 miniature tube.

Line cord.

Miscellaneous parts—wire, solder, screws, metal plate, small chassis, etc.

The oscillator coil is a conventional broadcast band tapped oscillator coil—designed for use in a 6SA7 or 12SA7 oscillator circuit. Such a coil can be purchased from any radio distributor or wholesaler and no special type number or manufacturer's name is necessary. Use an ohmmeter to identify the tap on the coil and wire the coil in the circuit exactly as shown in the schematic diagram (Fig. 1).

The details of the metal capacity plate are given in Fig. 5—these are the approximate dimensions of the plate shown in the illustrations. However, these dimensions are not critical—considerable variation is permissible and operation will still be achieved. The material used in the model is

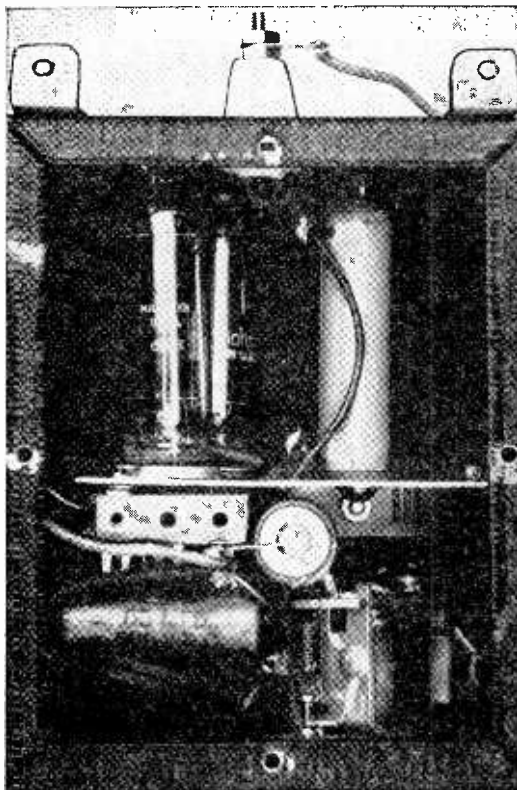

Fig. 3. Illustrates compact construction.

simply thin sheet copper which was cut in the rectangular shape with a pair of ordinary "snippers." Any other metal might be used—tin, steel, aluminum, brass, etc.

A piece of very thin tinfoil or lead-foil might also be used provided good contact can be made to the metal. Copper was chosen since it happened to be available and because it is quite easy to cut and it is quite easy to solder a connection to it. A flexible lead is soldered to the copper and run to the feed-through insulator on the capacity relay unit. The length of this lead is not too critical but it should not be made extremely long since it adds capacity and thus reduces the sensitivity of the unit.

The small chassis can be made from a piece of scrap sheet metal of suitable size. The exact size is not critical, as long as major parts can be easily mounted. Position of parts on the chassis is also not critical and the builder may use any convenient layout.

The first model of the relay was built "bread-

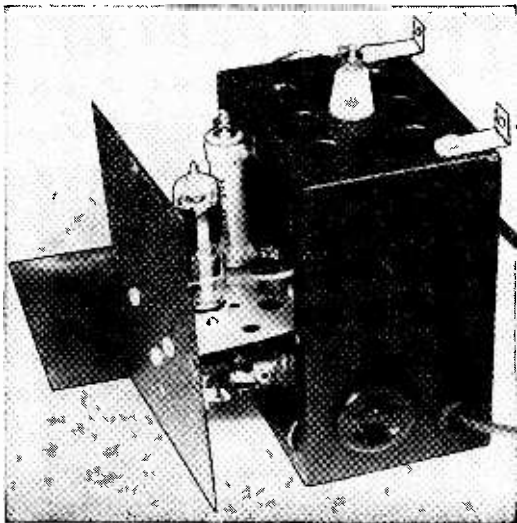

Fig. 4. Front panel and chassis one unit.

board fashion" — that is, the individual parts were soldered together to form the circuit and the tube sockets and other large parts were mounted on a piece of wooden board. This type of construction is desirable where experimentation is to be carried out—parts values changed, adjustments made, etc.

Since it was found that layout is not extremely critical, the unit might be built in any convenient metal case or cabinet or even in a wooden box if desirable. Be sure, however, that you provide ventilation holes if you enclose the unit. The 20 watt wire wound resistor, and the vacuum tubes themselves, get quite hot. Unless ventilation is allowed, the heat may accumulate within the case and cause other parts to be damaged.

Adjusting the Capacity Relay

Once the unit has been wired and assembled, your first move should be to plug in the unit and allow time for the filaments to heat. It will take somewhat longer than normal for the cathode to begin emitting due to the reduced operating voltages used on the tube filaments. Once the tubes have had time to heat properly, adjust the 370 micro-microfarad trimmer condenser until the relay closes. It may become necessary to adjust the tension spring on the relay—a small adjustment nut is provided on the relay for this purpose.

Adjust both the trimmer condenser and the adjustment nut on the relay until the relay just barely closes. Then change the adjustment on

the trimmer condenser until the relay just opens. Place your hand close to the metal plate (with-in one-quarter inch). The relay should close. If it does not, actually touch the metal plate with your hand.

In this case the relay should definitely be closed with a decided "click." If you find that the relay does not close, or that it vibrates in position, it indicates that further adjustment of the trimmer condenser and adjustment nut are necessary.

Even though layout is not extremely critical in this model, it may become necessary to change the size of the grid resistor of the 50P5 oscillator stage in order to get optimum operation with different parts. That is, there is a certain tolerance on all commercial parts and a slightly different oscillator coil may require adjustment in the value of this resistor. If optimum operation is not obtained at first, try experimenting with the value of this grid resistor. The other parts in the set (plate bypass condenser, filter condenser, etc.) are not critical.

Once you have adjusted the trimmer condenser, made changes in the value of the grid resistor if necessary, and adjusted the relay for optimum operation, you are ready to try the unit out.

Mount the capacity plate to a piece of glass or to a window, using strips of Scotch tape.

Plug in a floor lamp or some similar electrically operated device to the receptacle provided on the unit.

Now, bring your hand close against the opposite side of the glass so that the glass is between your hand and the capacity plate. As you press your hand close to the glass, the relay should trip, turning on the electrical device plugged into the receptacle. If not, it indicates that further adjustment of the trimmer condenser and relay is necessary. In other words, whenever you make an installation of the unit, and change the position of the lead-wire from the capacity plate to the relay unit or change the length of this wire, it is sometimes necessary to re-adjust the trimmer condenser and the relay tension spring.

Once you have the unit operating properly, and are able to turn an electrical device on by bringing your hand close to the glass and turn it off by moving your hand away from the glass, you are ready to set the unit up for other types of experimental work.

This unit, of course, has limited sensitivity since no amplification is provided. The limited sensitivity, in this unit, is desirable, since its main purpose is for display work. There are other uses too, which we will mention.

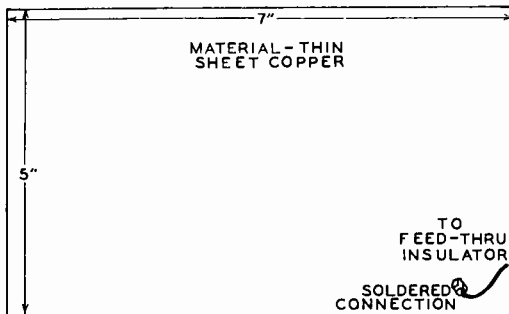

Fig. 5. Details of capacity plate.

Using the Capacity Relay

As an experiment, the original capacity relay model was installed in a local radio store. The metal plate was mounted in the store window with a sign between it and the window. Since the device was installed near Hallowe'en, electric lights were installed in several "pumpkin heads." These electric lights were connected to the capacity relay. A prospective customer would come to the store window, glance in at the displays, notice the small sign and metal plate.

When they placed their hand against the glass in front of the metal plate, the pumpkins would light—as the hand was moved away, the lights would go out. This provided quite an interesting display. The unit was left to operate continuously for a period of several weeks and attracted considerable attention in the neighborhood (which naturally led to more repair work and sales). This was about the simplest type of display that could be made.

Another type of display which could just as easily be made is illustrated in Fig. 6. An electric train power transformer is plugged into the unit so that it can be turned on and off by the action of the relay.

Customers can then make the electric train start and stop in the store window without touching any switches or controls. When the hand is placed against the window, the relay closes, supplying power to the train so that it moves around the track. When the hand is moved away from the window, the train stops.

Such a display attracts the attention both of children and adults. If there are a number of small children in the neighborhood, who may operate the device an excessive amount, as often happens, then the metal plate itself can simply be mounted higher on the window.

One good method is to make the metal plate itself a sign—painting it white or some other

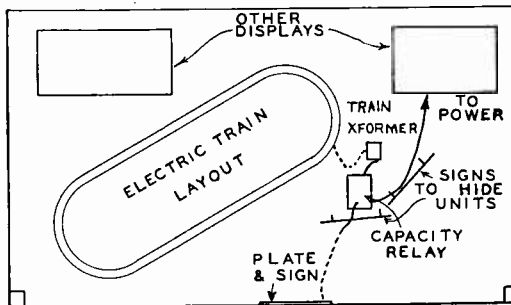

Fig. 6. Suggested electric train display.

light color and then having your message lettered on it.

A typical message follows:

**PLACE YOUR HAND HERE TO OPERATE
THE MYSTERY TRAIN**

There are a number of other displays which might be arranged. For example, a radio or television set might be mounted inside of a large partially enclosed box so that the interior is dark and the set could not be seen easily from the street. Lights could be arranged within the box which would flash on when the hand is placed near the metal plate.

A receiver, with the back cover removed, could be mounted on a slow moving turntable, controlled by the relay. As your hand is placed near the relay, the receiver would slowly turn around, allowing you to see the "insides."

Any electrically operated device can be easily controlled by the relay, so that a large number of displays could be arranged. It would even be possible to have several relays and plates controlling different devices in the same window.

Of course, the use of the capacity relay control of store displays is not restricted to radio and appliance stores alone. Such displays are particularly effective in large department stores, with a different electrically operated display in each window, and each controlled by a capacity relay.

Attention getting displays of this type form one of the best kinds of advertising since the prospective customer more or less "participates" in the action as he is able to control the display by placing his hand near the plate.

Therefore, the radio technician or serviceman may be able to make considerable additional money by building the units and installing them in local retail stores.

Naturally, the type of display would be suited to the store or to the general display in the particular window (of a department store). As an example, for a real estate office, a model house might be mounted on a turntable, with the back open. By placing your hand near the plate, the house can be made to turn slowly so that the interior can be seen from the back, with a display of doll furniture to give the appearance of a small furnished home. There is practically no limit to the variety of displays that might be arranged—the only restriction being the imagination of the person developing the display, the allowable cost of the display, and the availability of material necessary for constructing the display.

Nor is the use as a display control mechanism the only use to which the capacity relay can be put. For example, the metal plate might be mounted on a counter in the store. A sign could be placed on the plate as follows:

“Place Your Hand Here For Service”

The relay could be used to control an electric buzzer or bell at the rear of the store.

In this manner, if a customer should enter the store and no one is at the front counter, he could place his hand on the counter and get the attention of the manager or of a clerk.

The capacity relay can also be used at parties to control various “stunts.” The metal plate, being quite thin, could easily be laid under a tablecloth or thin magazine. Then someone sitting at the same table could cause various effects by simply placing his hand over the plate without leaving the table or removing his hands from the table top.

Here again, the variety of “stunts” that might be used are limited only by the imagination of the person making the installation.

Summary

The capacity relay is simply an oscillator whose intensity of oscillation is controlled by a change in capacity. This, in turn, is used to operate a relay, turning on (or off) electrical devices. It can be used for display work, performing “stunts,” or in similar applications. Extremely sensitive models, with amplifiers, can be used as burglar alarms but the model described in this article is designed primarily for display work.

The cost is comparatively low due to the simplicity of the circuits involved so that servicemen or technicians can make additional money by building the units and installing them in local stores. They can also be used, with considerable success, as attention getting devices in a radio or appliance store.

No pictorial diagram or detailed step-by-step instructions for building the unit have been prepared so that anyone attempting the construction should be familiar with conventional wiring techniques and should be able to build the unit by following the schematic diagram. As was mentioned at the beginning of the article, it is recommended that the work be undertaken only by more advanced students and graduates (unless the builder has had previous radio experience).

The ways of merchandising the capacity relay are as varied as the uses to which it can be put—it might be sold outright, sold, but an extra charge made for installation and adjustment, or might be rented on a weekly basis to interested stores or users.

In general, even if the commercial possibilities of the unit are not utilized, considerable enjoyment can be obtained by experimenting with the device.

Standard parts are used in the construction and should be obtained from your local wholesale distributor or from one of the large wholesale radio supply houses. **NRI CANNOT SUPPLY PARTS FOR BUILDING THIS UNIT!**

— n r i —

TELEVISION BOX SCORE

Stations Operating	28
Construction Permits Granted	78
Applications Pending	285

(AS OF JULY 5, 1948)

TELEVISION NEWS

by H. L. Emerson

Receiver production constantly increasing. Those manufacturers associated with RMA announced a total of over fifty thousand television receivers manufactured during the month of May, 1948. Total output for the first five months of the year amounted to 214,543 and total production since the end of the war now exceeds 400,000. (This does not include receivers manufactured by companies unaffiliated with RMA.)

Television soon to serve 40,000,000 people. According to a recent estimate by Arthur A. Brandt, General Sales Manager at General Electric's Electronics Plant, Syracuse, New York, Television will serve more than 40,000,000 people in the 140 principal U. S. markets within the next five years, and will develop into a \$600,000,000 receiver sales business at retail value at that time.

\$8 annual tax on London Television. The transmitter at Alexandria Place, in London, reaches approximately 50,000 receivers within a radius of forty miles. This transmitter is completely controlled by the Labor Government. So far Television is limited to the London area. An annual tax of \$8 per set has been paid on 39,000 receivers, and an additional 11,000 are believed to be operating in contempt of the tax collector.

Rapid expansion of Television stations predicted. If you have followed the "Television Box-Score" in the last two issues of this magazine, you will notice a steady increase in the number of stations operating and the number of construction permits granted. It is predicted that by midsummer of 1952, there will be a minimum of ninety Television stations in operation, if present plans materialize.

Coast-to-coast video network. According to Frank E. Mullen, NBC Executive Vice-President, a coast-to-coast video network will be in operation by 1950 from New York to Hollywood. By that time a West Coast network is also to have begun operation.

Convention Hall—Philadelphia. Sideline slants on Convention activities published in daily newspapers irritated Television people considerably. Reference was made in several papers about the "heat from Television lights." A press release was issued by the General Television Pool Committee advising newspaper men that the highly sensitive TV image orthicons did not need more than normal lighting. The heat stemmed from klieg lights erected by the film newsreel camera men—it was reported.

Trouble from TV receiver radiation. Receiver radiation may be one of the hurdles to good Television reception as the number of sets in use increases. Principal offenders will probably be some of the low price TV sets which are now being sold in quantities.

TV Channel No. 1 discontinued. The FCC has deleted Television Channel No. 1 (44-50 mc.) and assigned this channel to non-government fixed and mobile services. The band between 72 and 76 mcs. has also been allotted to the fixed services on condition that no interference will be caused to Television.

Tallest structure in New England. The new Television tower for Station WBZ-TV Boston is the tallest man-made structure in New England. The tower is 572 feet, on top of which is an 84 foot mast carrying both TV and FM antennas.

Zenith phone vision. According to Commander E. F. MacDonald, Jr., Zenith plans to have sets on the market this year which will receive both free and phone vision TV programs. Cost of the PV unit is to add approximately \$10 to the retail price of the set.

Westinghouse Stratovision. During political activities in Philadelphia, Television was successfully relayed to a plane flying over Pittsburgh, Pa. The programs were received as far as 200 miles farther west, and were also picked up in Washington, D. C.

More Brilliance from new TV tube. A new 10 inch direct-view television picture tube which gives approximately twice the light and improves image detail and contrast has been developed by General Electric. It employs an aluminum-backed fluorescent screen. The aluminum backing acts as a mirror which prevents loss of light and stray reflections inside the tube. The aluminum is vaporized inside the tube during manufacture and forms a reflector about eight-millionths of an inch thick.

Are you in Television? Even though TV is expanding with unbelievable rapidity, it is still relatively new to many of us. If you are working or experimenting in video, we would like to hear from you. Just tell us briefly what you are doing in this field. Address letters to: The Editor, NR News, 16th and U Sts., N.W., Washington, 9, D. C.

a radio in every room



a radio for everyone!

With power-packed advertising and selling, Hartford dealers in two weeks chalked up a 250% increase in sales as compared with the control city of Providence. The campaign was sponsored by the Radio Manufacturers Association.

The average radio serviceman or dealer is not very sales minded, but modern selling techniques are necessary in conducting a successful business. With this progressive viewpoint in mind, we have made available to NR News readers, in the succeeding article, material that should prove not only informative and timely but of great practical value in radio sales and service promotion.

The Editor of NR News is indebted to the publishers of Sales Management, the magazine which originally printed this article and from whom permission was obtained for reprinting portions of the article for the benefit of NR News readers. The illustrations also are through courtesy of Sales Management.

Strong Local Promotion Zooms Radio Sales in Hartford Test

HOW can individual radio dealers increase their sales? Can improved merchandising techniques and a new selling approach help the radio dealer sell more sets?

These questions are answered in the results of the two weeks Radio Manufacturers Association "Test Saturation" campaign in the Hartford, Conn., trading area.

The test was the first of its kind in the billion-dollar radio industry, and the verdict of leaders in the industry is that it is the most successful promotion in its history. The final record of the

campaign computed from data submitted by 108 dealers from two cities, Hartford where the campaign was undertaken and Providence where no special promotion took place—showed Hartford dealers outsold Providence dealers more than two and a half to one. The score was 2,505 sales for Hartford, 979 for Providence.

"This is not only an outstanding record, but it is also interesting to note that results showed that there was a corresponding increase in the unit sale of radio-phonograph combinations. It has opened new vistas to radio merchandising," says Stanley H. Manson, chairman of the Advertising

Here's the Pay-Off

"Furthermore, the importance of this campaign does not stop with the sales record. It provides proof that there is a new market for radios which still remains to be tapped," Mr. Manson points out.

"The significance of this campaign is best indicated by the dealers themselves who say that the campaign not only improved their sales records during the test period, but also gave them new sales techniques which could be used to increase their business the year 'round.

"The record set during the campaign, together with the unqualified endorsement of methods used, establishes a firm foundation of fact on which the radio industry can move forward boldly in developing expanded markets for radios. These markets until recently have existed in theory. The Hartford Test Campaign has proved them obtainable with the latest sales techniques."

RMA, on a national scale, had been using with great success the double-barreled theme "A Radio for Every Room—a Radio for Everyone." The basic idea was essentially personalized selling. Mother has her own table model radio in the kitchen; Sis, a combination set in her room; Johnny, a portable in the rumpus room; Dad, a car or chair-side radio—and of course, the family radio is the console in the living room.

Using this theme, the radio dealer could make multiple sales. It provided a method of expanding a market which might soon present a problem, since 93% of all homes in America own one radio.

With this in mind, RMA asked their public relations and merchandising counsellors, the Fred Eldean Organization, to test the new selling approach at the local level in one city.

From a test of this kind, it was believed, a successful pattern could be made available for other communities or individual dealers to follow and thereby increase their sales.

Hartford was selected as the most typical city for a two-week test. Providence, R. I., was chosen as the control city, because weather conditions, trading area and population in the two cities are almost identical. It was arranged that during

	HARTFORD	PROVIDENCE
	(With two weeks of intensive promotion)	(Same two weeks, but no special promotion)
Number of stores reporting	108	108
Total sales reported (No.)	2,505	979
Sales (No.) first week	1,102	502
Sales (No.) second week	1,403	477
Average sales per store during campaign	23.19	9.06
Consoles sold during campaign	344	219
Other sets sold during campaign	2,161	760
Stores reporting no sales during campaign	4	14

the two-week test period in Hartford there would be no special activities planned for Providence. In that city it would be "business as usual."

All details had been carefully planned in advance. The Mayor of Hartford was there to greet the dealers. Representatives from the local newspapers, together with photographers, covered the meeting. Lee Pettit, representing the RMA Radio-In-Every-Room Committee, pointed out that the test would demonstrate the active interest and effective help which it was the aim of radio manufacturers to give to radio dealers.

As tangible evidence of this support, all dealers were given kits which included:

1. Two streamers dramatizing the Radio-In-Every Room, Radio for Everyone theme for window displays.
2. Two counter cards with the same theme and artwork, also for window displays.
3. Salesmen's leaflet, titled "What's In It For Me?"
4. Questionnaires to be filled in by customers—these to provide a prospect list.
5. A chart to enable the buyer to record sales during the test period.

The dealer meeting had been a success, but . . .

there would be a lapse of two weeks between that time and when the test campaign was scheduled to begin. To avoid loss of enthusiasm, these steps were taken:

A series of promotional pieces reached dealers every few days.

During all this time plans for publicity were carefully laid:

NEWSPAPERS—A 1,000-word interior decorations article was scheduled to break in the Sunday magazine of *The Hartford Courant*.

A women's page feature article was scheduled to break during the second week of the campaign in *The Hartford Times*.

BROADCASTING STATIONS—All stations in the Hartford area received individual 15-30 and 50-second spot announcements for use during the two-week test period. Special programs were planned and 12 scripts supplied for half-hour shows.

Then came Sunday, the day the Hartford Spring Radio Showing was scheduled to break.

When Mr. and Mrs. Hartford awoke that Sunday morning, they read about the Hartford Spring Radio Showing in the local newspapers, heard about it on the air, saw it dramatized in store windows.

And during the two-week test:

WINDOW DISPLAYS—Almost every store in Hartford had interpreted the twin theme and used it in window displays. Large stores used lavish displays. G. Fox had a three-foot doll's house with streamers from each room to an actual radio for that spot in the home. Moran's Furniture Store had a 12-foot blowup of the RMA poster to greet motorists as they entered New Britain. Smaller stores utilized the posters and streamers in effective and varied ways.

ADVERTISING—During the two-week period almost all advertisements were keyed to the personal possession theme.

Interesting is the fact that the RMA spent no money on newspaper or radio advertising. All retailers paid for their own advertising. All six local radio stations cooperated in programming to bring in the decorative features of the new designs in radio sets. Local newspapers cooperated in running full-page, illustrated articles.



Courtesy of Sales Management Magazine

LEST THEY FORGET . . .

the Henry Moran & Sons furniture store placed new portable radios throughout the luggage department.

The results?

Hartford made 2½ times as many sales as Providence during the same period. The test showed conclusively that with a new selling approach dealers could sell more radio sets. Dealers in the Hartford area are not only pleased with the results, but they point out that what pleased them most is the fact that they now have an idea which can improve their businesses not only for two weeks, but for 52 weeks of the year.

— n r i —

Crooked Game

Pistol Pete was in the middle of one of those historic western poker games that continued for days, or until all of the shirts were gone. Finally, at the end of the first day, Pete arose from his chair, pulled out his gun, and announced to the players:
"This game is crooked. Joe there ain't playing the hand I dealt him."

EVERYBODY GETS THE BLUES

By

Dr. James F. Bender, Director

The National Institute for Human Relations

Copyrighted, all rights reserved

ARE there times when nobody loves you? When everybody hates you? When you guess you'll go eat worms? Then don't be discouraged, because you are in the same boat with everybody else.

It's the nature of our emotions to swing high, swing low. Professor Rex B. Hersey of the University of Pennsylvania, pioneer in the study of the rhythmic swing of the emotions, based his conclusions on a large number of workers he observed and tested over a period of an entire year. *Not one of the workers escaped ups and downs of temperament.*

Out of all the research and observation some very helpful applications are now available. For once we know the swings our emotional pendulum takes, we can keep our clock of human relations in better order. So the first thing to do is to study the frequency of your ups and downs.

Do you feel elated every two weeks, or five or seven? We vary greatly in the spacing of mood swings. But we are alike in that they recur in the lives of all of us.

You too can plot the curves of your emotions, just as Professor Hersey did when he studied the workers. At the side of a piece of graph paper you write at regular intervals: Super-happy, Happy, Cheerful, Interested, Mildly pleasant, Neutral, Mildly unpleasant, Peevish, Angry, Disturbed, Sad, Apprehensive, Worried. Then on the bottom, starting at the left, number the days—each line representing a day. Every day put a dot opposite the mood that applies best. Do this for two or three months and then connect all the dots. You will then have a valuable clue to your personality. For the waving lines will show you how your temperament fluctuates.

When you are riding the crest of a wave, your energy is boundless, even difficult tasks seem easy, and all's right with the world. When you

descend into a valley you are irritable, indifferent, and people annoy you. Seclusion is what you want, and failures drive you to deep worry.

Once you know what's coming emotionally, you can trim your sails accordingly. During the peaks, that's the time to set about your difficult tasks, lay your large plans. It's the time when you make the best host or hostess. If you want your bridge party to be a success, plan it for the "uptake."

When you are low, do the things that require you to be alone. If you have routine or tedious work to do save it if possible, for such periods. Keeping busy at something, no matter how simple it is to do, helps you to work out of the "trough." The low periods are useful to criticize your grand plans, too.

Professor Hersey recommends as the best part of the total cycle the portion that hovers around *neutral plus*. That is where you do your best work, come to the sanest conclusions, and can look on the world and your associates with the steadiest eye.

Once you study yourself, you are also in a good position to analyze the moods of your wife or husband or boss. When she is in the dumps, that is a good time to bring flowers or a box of candy. When he is in the worried phase, that is the poorest time to broach the prospects of a new fur coat.

When we hear people say, "He's a good psychologist" (about someone on the job), they probably have in the back of their minds the same discovery made by Professor Hersey. If you know when to expect your mood cycles you can act accordingly—and to the welfare of yourself and others. And this is a valuable discovery that everyone will want to make whether he has to go to the trouble of plotting his moods or not.

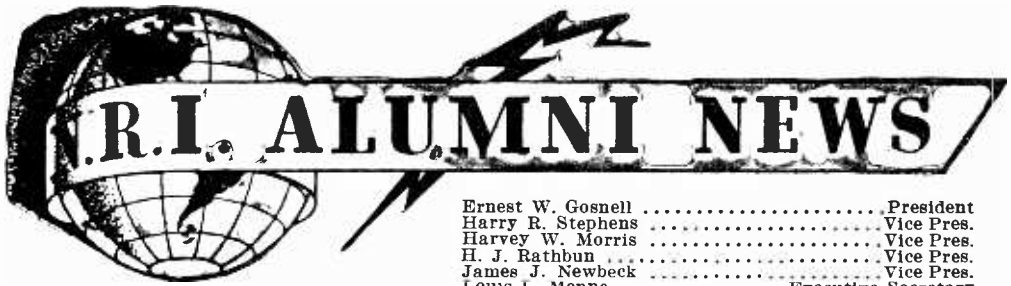

Ernest W. Gosnell	President
Harry R. Stephens	Vice Pres.
Harvey W. Morris	Vice Pres.
H. J. Rathbun	Vice Pres.
James J. Newbeck	Vice Pres.
Louis L. Menne	Executive Secretary

NOMINATIONS FOR 1949

THERE is a well-known poem the first few lines of which run along like this:

*"Around the corner I have a friend,
In this great city that has no end,
But days go by and weeks rush on
And before I know it a year is gone.*

*But I never see my old friend's face
For life is a swift and terrible race."*—

Time does indeed rush on. Here again it is time to hold our annual election. This election will take form during the month of October. The final day for voting will be October 25.

It is now necessary to call for nominations. The names of the nominees will be published in the October-November issue of NR NEWS. That, of course, is our next issue.

Five officers are to be elected. They are a President and four Vice Presidents.

When you joined the Alumni Association you were sent a copy of our Constitution. However, you may have misplaced it and just to refreshen your memory we quote from Article VI of the Constitution, as follows:

1. The election of the President and the Vice President shall be by ballot.

2. The President shall be eligible for re-election only after expiration of at least one year following his existing term of office, and when not a candidate for President, may be a candidate for any other office. Other officers may be candidates to succeed themselves, or for any other, but not more than one, elective office in the Association.

3. The election of officers shall be held in October

of each year, on the day designated by the Executive Secretary, but not later than the twenty-fifth of the said month.

4. The Executive Secretary shall advise Members by letter, or through the columns of the National Radio News, on or before August first of each year that names of all nominees shall be filed in his office not later than August twenty-fifth following.

5. Each Member shall be entitled to submit, in writing, one nomination for each office, and the two nominees receiving the highest number of votes shall be the nominees for the office for which nominated.

6. The Executive Secretary, before placing any name on the ballot, shall communicate with each nominee, to ascertain his acceptance of the office, if elected. If such tentative acceptance is withheld, the eligible nominee having the next highest number of votes shall be the nominee for that office.

7. The Executive Secretary, on or before October first of each year, shall furnish Members a ballot listing the names of the nominees for each office.

8. No Member shall be entitled to vote if he is in arrears in the payment of dues.

9. Ballots, properly executed and valid according to the instructions plainly printed thereon, shall be returned to the Executive Secretary on or before midnight of October twenty-fifth of each year.

10. The Executive Secretary shall designate three Election Tellers from the staff of the Institute, who shall count the ballots and certify the re-

sults, together with the return of the ballots, to the Executive Secretary.

11. In the event of a tie vote for any office, the Executive Secretary shall cast the deciding ballot.

12. The nominee receiving the greater number of votes for the office for which nominated shall be declared by the Executive Secretary to be elected to that office, and notice of such election shall be forwarded in sufficient time, prior to January one, to permit such elected officer to enter upon the duties of said office on that date.

The ballot will be found on pages 27 and 28. The polls for nominations will close August 25. This will give us five days in which to count the votes and announce the nominees in the October-November issue which goes to the printer on September 1. Balloting on the nominees will then take place and the successful candidates will be announced in the December-January issue of NATIONAL RADIO NEWS in time to take office on January 1, 1949.

One of our most conscientious Presidents, Mr. Ernest W. Gosnell of Baltimore will, on January 1, relinquish the office to his successor. No man ever wore the mantle of President more proudly than does Mr. Gosnell. We spent several very interesting evenings in the home of Mr. Gosnell. One could picture the great American family. A fond father, a devoted wife, and bright happy young folks including several grandchildren. It was comforting to visit with these good people. Ernest Gosnell typifies the true American father.

In order that our members may have a list of candidates to choose from we are submitting some names of members located in various parts of the country. These are submitted merely to be of assistance. See below and pages 28 and 29.

We have only two recommendations. We suggest that Harry Andresen of Chicago is in line for serious consideration for President. Another loyal Alumnus is Charles H. Mills, a charter member of Detroit Chapter. Mr. Mills would make an excellent Vice President and certainly deserves the honor.

— n r i —

Nomination Suggestions

Gorden E. DeRamus, Selma, Ala.
Don Smelley, Cottondale, Ala.
H. E. Nichols, Bisbee, Ariz.
Edgar E. Joiner, El Dorado, Ark.
A. R. Waller, Keo, Ark.
Oliver B. Hill, Burbank, Calif.
Jos. E. Stocker, Los Angeles, Calif.
Herbert Garvin, Los Angeles, Calif.

(Page 28, please)

Nominations

All Alumni Association Members are requested to fill in this Ballot and return it promptly to National Headquarters. This is your opportunity to select the men you want to head your association. Turn this page—the other side is arranged for your selections.

After the ballots are returned to National Headquarters, they will be checked carefully and *the two men having the highest number of votes* for each office will be nominated as candidates for the 1949 election. The election will be conducted in the next issue of NATIONAL RADIO NEWS.

The President cannot be a candidate to succeed himself, but you may nominate him for Vice-President if you wish. You may, however, nominate all Vice-Presidents who are now serving, to succeed themselves, or select entirely new ones. It's up to you—select any men you wish as long as they are MEMBERS IN GOOD STANDING OF THE NRI ALUMNI ASSOCIATION. Be sure to give the city and state of your selections to prevent any misunderstanding.

The offices of Secretary and Executive Secretary have been combined. The Executive Secretary is appointed by the Board of Trustees and is no longer an elective office. Vote only for a President and four Vice-Presidents.

Detach this slip carefully from your NATIONAL RADIO NEWS so as not to damage the book. Tear off the slip at the dotted line, fill it out carefully, sign it, and return it immediately to L. L. Menne, Executive Secretary, NRI Alumni Association, 16th and U Sts., N.W., Washington 9, D. C.

The 1949 nomination is a very important one. Choose carefully the men you desire to handle the reins of the Alumni Association for the coming year. Let's all do our part to help the staff handling the elections, by submitting ballots early. Polls for nominations close August 25, 1948.

Nomination Ballot

L. L. MENNE, *Executive Secretary*,
NRI Alumni Association,
16th and You Sts., N.W.,
Washington 9, D. C.

I am submitting this Nomination Ballot for my choice of candidates for the coming election. The men below are those whom I would like to see elected officers for the year 1949.

MY CHOICE FOR PRESIDENT IS

.....
City State

MY CHOICE FOR FOUR VICE PRESIDENTS IS

1.

City State

2.

City State

3.

City State

4.

City State

Your Signature

Address

City State

Student Number

Nomination Suggestions

(Continued from page 27)

P. A. Abelt, Denver, Colo.
A. H. Wilson, Leadville, Colo.
W. R. Haberlin, Bridgeport, Conn.
David McKendrick, Devon, Conn.
Joseph Snyder, Danbury, Conn.
Jesse O. Starr, Darien, Conn.
Wm. F. Speakman, Wilmington, Del.
Jos. Certesio, So. Wilmington, Del.
J. J. Jenkins, Washington, D. C.
Robert E. Many, Washington, D. C.
Charles W. Hoffman, Washington, D. C.
Wm. G. Spathelf, Washington, D. C.
Glen G. Garrett, Bonifay, Fla.
Austin L. Hatch, Ft. Lauderdale, Fla.
Stephen J. Petruff, Miami, Fla.
W. P. Collins, Pensacola, Fla.
Chas. W. Hardigree, Macon, Ga.
R. R. Wallace, Ben Hill, Ga.
Joseph Bingham, Twin Falls, Idaho.
Arvil H. King, Montpelier, Idaho.
Lloyd Immel, Chicago, Ill.
Robert Reid, Evanston, Ill.
Fred J. Haskell, Waukegan, Ill.
Harry Andersen, Chicago, Ill.
Harold Bailey, Peoria, Ill.
Lowell Long, Geneva, Ind.
Chase E. Brown, Indianapolis, Ind.
Russell Tomlinson, Marion, Ind.
H. E. McCosh, Charles City, Iowa.
E. C. Hirschler, Clarinda, Iowa.
Erney Cunningham, Olathe, Kans.
Wm. B. Martin, Kansas City, Kans.
K. M. King, Wichita, Kans.
Wm. S. Nichols, Cynthiana, Ky.
E. V. Hess, Louisville, Ky.
L. H. Ober, Alexandria, La.
Lawrence Merz, New Orleans, La.
Walter Dinsmore, Machias, Maine.
Harold Davis, Auburn, Maine.
Ralph E. Loke, Calais, Maine.
H. J. Rathbun, Baltimore, Md.
J. B. Gough, Baltimore, Md.
Samuel Robinson, Hagerstown, Md.
G. O. Spicer, Hyattsville, Md.
Laurence E. Grant, Belmont, Mass.
Louis Crestin, Boston, Mass.
A. Singleton, Chicopee, Mass.
Omer Lapointe, Salem, Mass.
Robert Swanbum, Duluth, Minn.
Arthur J. Haugen, Harmony, Minn.
A. R. Stewart, Staples, Minn.
F. Earl Oliver, Detroit, Mich.
Chas. H. Mills, Detroit, Mich.
Harry R. Stephens, Detroit, Mich.
Floyd Buehler, Detroit, Mich.
Al Fisher, Clarksburg, Miss.

Robert Harrison, West Point, Miss.
C. S. Burkhart, Kansas City, Mo.
A. Campbell, St. Louis, Mo.
C. W. Wichmann, Inverness, Mont.
Carl M. Darner, Sweet Grass, Mont.
V. S. Capes, Fairmont, Nebr.
Albert C. Christensen, Sidney, Nebr.
C. D. Parker, Lovelock, Nev.
Emmitt R. Towers, Ely, Nev.
Clarence N. George, Dover, N. H.
E. Everett Darby, Woodsville, N. H.
J. A. Stegmaier, Arlington, N. J.
Delbert Delanoy, Weehawken, N. J.
Claude W. Longstreet, Westfield, N. J.
O. B. Miller, Albuquerque, N. Mex.
George Baum, Hagerman, N. Mex.
Aurelius Schumacher, Buffalo, N. Y.
Alfred R. Guiles, Corinth, N. Y.
James J. Newbeck, New York, N. Y.
L. J. Kunert, Jamaica, L. I., N. Y.
Charles W. Dussing, Syracuse, N. Y.
Henry M. Gort, Richmond Hill, L. I., N. Y.
Irvin Gardner, Saratoga, N. C.
Max J. Silvers, Raleigh, N. C.
Arvid Bye, Spring Brook, N. Dak.
Jacob J. Knaak, Cleveland, Ohio.
H. F. Leeper, Canton, Ohio.
Chas. H. Shipman, E. Cleveland, Ohio.
Byron Kiser, Fremont, Ohio.
Pat Thompson, Oklahoma City, Okla.
Emil Domas, Dale, Oreg.
H. M. Pruner, Newport, Oreg.
Harvey Morris, Philadelphia, Pa.
Elmer E. Hartzell, Allentown, Pa.
Chas. J. Fehn, Philadelphia, Pa.
William Dyson, Pawtucket, R. I.
James F. Barton, Greer, S. C.
Joel J. Lawson, Aberdeen, S. Dak.
Chester Warren, Lead, S. Dak.
Argil Barnes, Jonesboro, Tenn.
J. H. Crowley, Jr., Memphis, Tenn.
Dan Droemer, Ft. Ringgold, Texas.
Richard Mallard, Dallas, Texas.
W. L. Davis, Provo, Utah.
Clyde Kiebach, Arlington, Va.
A. P. Caldwell, Buchanan, Va.
T. E. Ellis, Richmond, Va.
Walter Leland, Orleans, Vt.
H. L. Larson, Seattle, Wash.
Alfred Stanley, Spokane, Wash.
G. Blomberg, Aberdeen, Wash.
G. McCollum, Spencer, W. Va.
Wm. Wiesmann, Fort Atkinson, Wisc.
J. C. Duncan, Duncan, Wyo.
Robert Kirkham, Calgary, Alta., Canada.
M. Martin, New Westminster, B. C., Canada.
E. D. Smith, Winnipeg, Man., Canada.
Ernest Earle, St. John, N. B., Canada.
Russell Burhoe, Woodstock, N. B., Canada.
Donald Swan, Springhill, N. S., Canada.
G. C. Gunning, Smith's Falls, Ont., Canada.
E. Bergeron, Sherbrooke, P. Q., Canada.
Thos. Crook, Saskatoon, Sask., Canada.

Chapter Chatter

Our members tells us they like this style of reporting so we will try it again this issue. . . . Let us start with Baltimore Chapter. Some of the larger Chapters better look to their laurels. Percy Marsh as Chairman and Arthur F. Lutz as Secretary, assisted by a staff of capable officers, make a team hard to beat. . . . A recent visitor was Mr. Emile Swanson of Woodbine, Maryland. We are always very glad to have visitors. . . . A tip of the hat from members of Baltimore Chapter to the Editor for the nice pictures in the last issue of the NEWS. . . . Let's see, Carl Strupp and Albert Klein were two of our speakers. Vice President Rathbun also made a fine talk on Second Detectors. . . . Another visitor, this time Robert Coverston. . . . The idea of asking a question to be discussed at the following meeting is working out splendidly. Here is an example. One question: "In a commercial receiver, how would you determine whether the I.F. would be above or below the incoming frequency and how would you correct it?" Mr. Stokes lead this discussion . . . very interesting . . . we also had a lengthy discussion on the installation of TV and FM antennas. . . . Following the example of Detroit Chapter we now are wearing lapel buttons for identification purposes. This is a good idea. Easy to get acquainted and helps to remember names.

Over to New York Chapter now . . . any time they have less than fifty-five in attendance they think they are having a bad night. Signed up seven new members one night. All were introduced by Chairman Bert Wappler . . . Eugene Williams spoke on Television repairing. . . . Always a very interesting speaker. . . . William Fox gave us a humorous talk on a television receiver he bought. Had the fellows in stitches telling about all of his troubles. . . . Dick Patten gave a splendid talk on "Finding Trouble in the Oscillator Section of the Receiver." For this talk Dick used our Demonstration Board. Always ready and always good, Dick Patten is a great asset to our Chapter.

At a more recent meeting Joel Robinson gave us a nice talk. His subject was "The Radio Serviceman and House Wiring." . . . William Fox again spoke on Television. This was followed by Ralph Georg who gave us a wonderful talk on "High Voltage." Our usual practice is to have an informal discussion after each talk. The speaker answers any questions which are put to him by our members. . . . Another shining light is Edward Cooper, one of our newer members, who spoke on a Signal Tracer he built. We look forward to hearing more from this interesting member. . . . Vice Chairman Alex Remer usually conducts our Question and Answer forum. Always does a swell job. Sometimes is assisted by Frank



Members of Detroit Chapter, with their ladies, had a great time at their annual dinner party, held June 16th. Here they are at the banquet table in the beautiful Elmwood Hotel in Windsor, Ont., Canada, just across the river from Detroit.

Detroit Chapter Annual Party

On June 16 Detroit Chapter held its annual dinner party at the Elmwood Hotel in Windsor, Ontario, Canada. These affairs are always an outstanding event in the year's activity of Detroit Chapter. As usual the party was a complete success in all respects.

After a very delicious steak dinner the program got under way with some interesting introductory remarks by Chairman F. Earl Oliver. In turn he introduced the Master of Ceremonies, Mr. Harold E. Chase. Always at his best in a situation of this kind, Mr. Chase kept everyone entertained with his witty remarks and stories.

Mr. Chase then presented Mr. L. L. Menne, Executive Secretary of the National Radio Institute Alumni Association, who was our guest. Mr. Menne spoke on the activities of the Alumni Association. Near the close of his remarks, we met some very serious competition from an orchestra in the main dining room. Came the voice of another M. C. to announce that it was Show Time. And, sure enough, when the doors were pulled back there were the show girls, the actors, the ventriloquist, the dancers to entertain us for a good hour.

Following this, we returned to our own program

Page Thirty

and began the drawing for prizes. These prizes were donated by members of the Chapter and local radio supply houses. Prizes were a combination lunch maker and coffee maker, and a toaster for the ladies. These were won by Mrs. Patz and Mrs. Kacel. For the men, there was a book "The Oscillator at Work," donated by Harry Stephens and won by Larry Upham, another book "FM Transmission and Reception," donated by Chairman F. E. Oliver, another F.M.-Rider, donated by Floyd Buehler. The Oliver prize was won by Mr. Patz and the Buehler prize was won by Mr. Grajek. Other prizes were a soldering iron donated by Radio Supply and Engineering Company and won by Mr. Shutock, a book "Rider's Automatic Record Changers and Records," drawn by Mr. Kacel, and Rider's Volume 16, which was drawn by Mr. Clarence McMaster.

There was plenty to eat, plenty to drink and excellent music for dancing. Great thanks is given to the officers and committee members who made this party such a fine affair. Of special mention is Chairman Oliver, Vice Chairman Mills, Secretary Stephens, Assistant Secretary Upham, and Librarian Floyd Buehler. Particular mention should be given to our Canadian members, Jack Hasen and Clarence McMaster who did the spade work in making arrangements at the Elmwood Hotel and who arranged for maps

and windshield stickers for complete directions. Mr. Hasen and Mr. McMaster then stationed themselves at the far end of the Windsor Tunnel in Canada to see that all understood directions and that those who might be in need of a ride would be accommodated.

Returning from the party by automobile, Mrs. Oliver, Earl Oliver and Milton Oliver, insisted that Menne be taken for a boat ride. Menne however declined the invitation and insisted upon being taken to his hotel. Swimming around in the Detroit River in pitch darkness is one of the things Menne does not do well.

Detroit Chapter is in recess for the summer. Regular meetings will be resumed in September and announcements regarding dates and program will be made in the next issue of NR News.

Chapter Chatter

(Continued from page 29)

Zablocki and Peter Sales.

As this issue goes to press we are planning a social meeting. More about this to be reported later. . . . Our members decided to hold our meetings right through the summer. Why interrupt a good thing?

In Philadelphia, Harvey Morris, Chairman and a National Vice President, continues to do his very fine job. Harvey is giving us a series of talks on Television . . . very good and have boosted our attendance. Our Chairman is quite an authority on Television. . . . Morris Segal has taken over the job of Financial Secretary in place of Milton Devac whose work makes it quite difficult for him to attend meetings regularly. Segal is doing a good job. . . . The old dependables, Norman Kraft, Charles Fehn, John McCafferty, and Robert Meili should get special mention. . . . They never miss a meeting.

During July and August we are holding only one meeting—the first of the month. We decided to suspend our second meeting but beginning in September we will go back to the two meetings a month. Fine spirit in Philadelphia. Always glad to have visitors.

A report of the dinner party held by Detroit Chapter is given elsewhere in this issue. It was one of the best ever. Attendance, however, was not quite up to expectations, perhaps because it is quite some distance to Windsor for many of our members. We look forward to these annual parties and work very hard to make them a success. Next year we may try something a little different . . . we have something in mind which may appeal to more of our members. Planning a year in advance . . . that's Detroit Chapter for you. A little something now about our meetings.

Chairman Earl Oliver conducts the service forum and, as usual, does a fine job. Max Ludtke set up the cokes. . . . One of our old timers, Jack Hasen, attended our last meeting. Says Mrs. Hasen, who has been quite ill, is improving and Jack hopes to be with us regularly before very long. . . . New members admitted were Anthony Biondo and Kenneth L. Kacel. . . . By the way an orchid each to Chairman F. Earl Oliver, Harold E. Chase, who acted as master of ceremonies at the party and did a swell job, and committee members Charles H. Mills, Harry R. Stephens, Larry Upham, Leonard Winkelman, Clarence McMaster, and Floyd Buehler, for a splendid job in connection with the party. Also to the musicians whose names we need not mention.

At our last meeting we had a sound motion picture as the feature attraction . . . very good . . . Robert N. Jones was admitted as a new member. . . . No meetings during July and August. Watch for important announcement regarding big meetings to open our Fall season beginning September. This announcement will appear in the next issue of NR News.

Now to Chicago . . . where Albert Horvath holds forth as Chairman. Horvath has succeeded Lloyd Immel, who resigned because he was unable to attend meetings. Night work. Good man, Mr. Horvath. . . . Fellows are very anxious to build a Television kit. Scouting around to see which is the best to buy. Tipped off by Menne to sit tight for awhile. . . . NRI may have some interesting information on the subject before many months. . . . Fred Korn taking a lively interest in our Chapter affairs. . . . Attendance is increasing. The boys are plugging to nominate Harry Andresen for National President for 1949.

Until next month . . . good luck and keep smiling.

Local Chapter Meetings

NEW YORK—Meet at 8:15 P.M. on 1st and 3rd Thursday of each month at St. Mark's Community Center, 12 St. Mark's Place—between 2nd & 3rd Ave., New York City.

PHILADELPHIA—Meet at 8:15 P.M. on 2nd and 4th Monday of each month at 4510 Frankford Ave. (third floor). (No 2nd meeting in August.)

BALTIMORE—Meet at 8:15 P.M. on 2nd and 4th Tuesday of each month at 745 West Baltimore St.

DETROIT—Meet at 8:15 P.M. on 2nd and 4th Friday of each month at Electronics Institute, 21 Henry St., corner Woodward (fourth floor). (No meetings in August.)

CHICAGO—Meet at 8:15 P.M. on 2nd Wednesday of each month at 2759 So. Pulaski Road.

NATIONAL RADIO NEWS

FROM N. R. I. TRAINING HEADQUARTERS

Vol. 13 August-September, 1948 No. 4

Published every other month in the interest of the students
and Alumni Association of the

NATIONAL RADIO INSTITUTE
Washington 9, D. C.

The Official Organ of the N. R. I. Alumni Association.
Editorial and Business Office, 16th & You Sts., N. W.,
Washington 9, D. C.

L. L. MENNE, EDITOR
J. B. STRAUGHN, TECHNICAL EDITOR

NATIONAL RADIO NEWS accepts no paid advertising. Articles referring to products of manufacturers, wholesalers, etc., are included for readers' information only, and we assume no responsibility for these companies or their products.

Index

Article	Page
Editorial	2
Magnetic Recording	3
Building and Using a Hand Capacity Relay	15
Television News	21
Strong Local Promotion Zooms Radio Sales in Hartford Test	22
Everybody Gets the Blues	25
NRI Alumni Association News— 1949 Nominations	26
Nomination Ballot	28
Chapter Chatter	29

Printed in U.S.A.

NATIONAL RADIO NEWS
16th & U Sts., N.W., Washington 9, D. C.
Published every other month by
National Radio Institute

For:

Mr. Harold R. Rueth
RFD 3
Jefferson, Wis.

226 YE 42

2A

U. S. POSTAGE
1c PAID
Washington, D. C.
Permit No. 7052