

NATIONAL RADIO NEWS



June-July
1948

IN THIS ISSUE
Antennas for FM and Television
Diagnosing Receiver Troubles
Alumni Association News

VOL. 13
No. 3



ASK WHY

The ability to observe *intelligently*—to learn—to gain information—depends greatly upon your willingness to ask **WHY**.

Don't simply take things for granted. Get in the habit of asking other people **WHY**. And most important of all, *ask yourself* **WHY**—then find out the answers!

Be a *student* for the rest of your life—be a person who seeks knowledge—be a person who *wants to know*—be a man who *asks* **WHY**!

Thomas Edison became rich and famous because he was curious about the *reasons* for this and the *reasons* for that. He asked himself and others **WHY**. Alexander Graham Bell was able to invent the telephone, because he asked **WHY**. Marconi discovered much about Radio because he had the habit of asking **WHY**.

And so I advise you—a man who wants to know more and more about Radio—to develop the lifetime habit of asking **WHY**. This will contribute much to your eventual success.

J. E. SMITH.

Antennas for FM and Television

by
By J. A. DOWIE
Chief Instructor



J. A. Dowie

THE purpose of this article is to present information concerning modern FM and TV (Frequency Modulation and Television) antennas and their installation. The fundamental principles are covered in the NRI Course and will not be reviewed here in detail but some basic theory will be given.

Perhaps the most important factor to consider

in any discussion of antennas is the frequency of operation. The new FM band extends from 88 to 108 megacycles. The Television Channels are depicted in Fig. 1. The lowest frequency involved is 44 mc. (megacycles) and the highest is 216 mc. which is an exceptionally wide range of frequencies. To secure efficient antenna operation over such a wide range is very difficult but commercial designs offer reasonably good results.

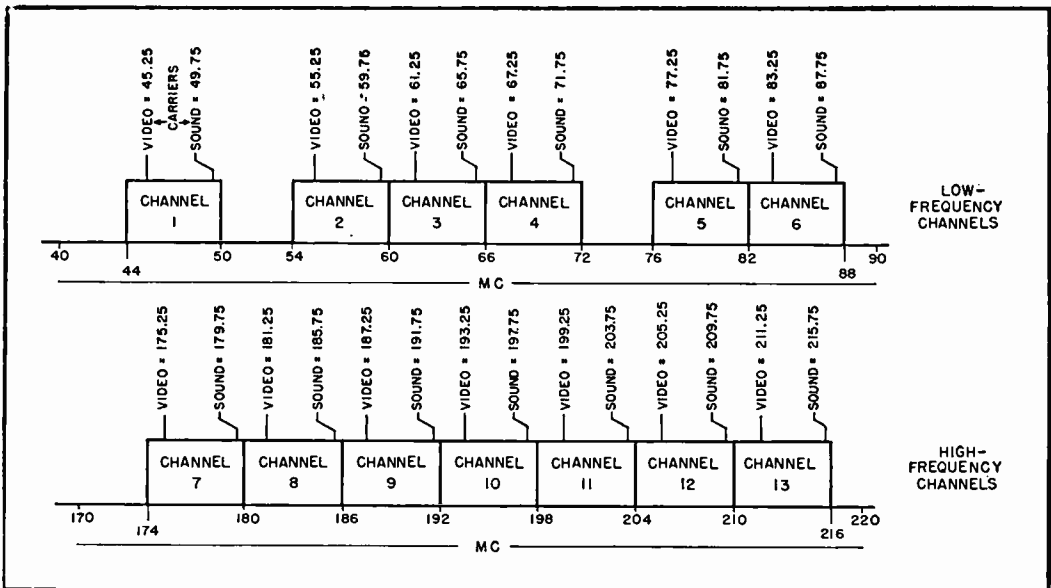

Courtesy of SERVICE Magazine

Fig. 1. Allocation of TV Channels.

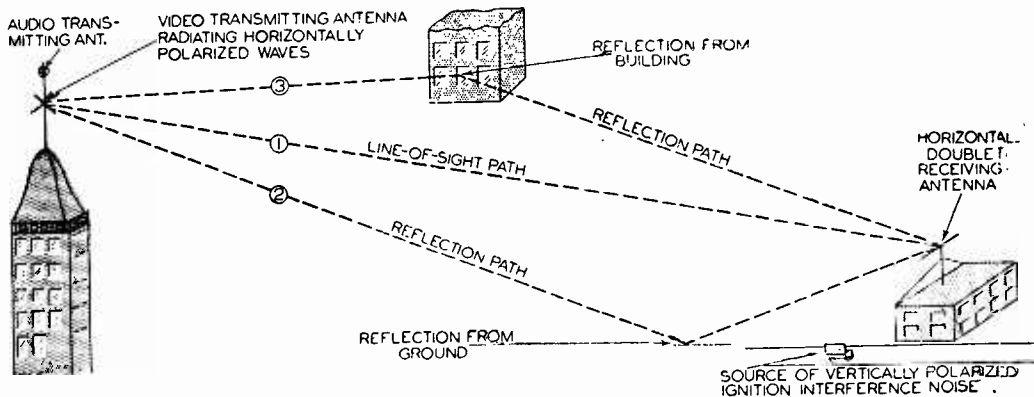

Fig. 2. Possible paths for reception of VHF signals.

When the frequency is very high (VHF, very high frequency, applies to the 30-300 mc. range) the radio waves behave like light waves. That is, they tend to travel in straight paths and do not bend readily. Also, like light waves, these VHF waves can be reflected. This is illustrated by Fig. 2. For good results, the receiving and transmitting antennas should be within sight of each other, or nearly so, and when such a path is obtained the reception is "line-of-sight."

When multiple paths exist the lengths of the paths are not alike, and time differences exist between the waves arriving at the receiving element—the signals are out of phase. In FM the result may be distortion apparent to the ear. In TV reception, visual distortion—apparent to the eye—occurs.

For maximum range, the television transmitting and receiving antennas should be as high as possible. This is why many TV Transmitter antennas are located on mountain tops, on hill-tops or at the tops of tall office buildings in cities.

At the receiver, the antenna is mounted on the roof of the building and as high as practicable. In residential sections a height of from 30' to 40' above the ground or 10' to 20' above the roof is, in most cases, satisfactory.

Antenna Elements

On the AM broadcast band, a short piece of wire or a loop antenna may be sufficient, under favorable circumstances, to permit reasonably good reception. On FM and TV frequencies, however, the story is quite different. The outside antenna is a necessity for high quality reception as a general rule. In some very unusual locations, a loop or short piece of wire may be sufficient for FM reception.

Page Four

The Dipole

About the simplest antenna you could visualize would be an ordinary, straight piece of wire. However, its length must bear some definite relationship to the wavelength of the signal. If we make the antenna a half wavelength long, it will be an efficient device for picking up radio waves. (A standard half-wave dipole is shown in Fig. 3.) The next step is to transfer the energy in the antenna to the set. If we split the $\frac{1}{2}$ wave antenna into two sections by cutting it in the middle, each section will be a $\frac{1}{4}$ wave long. The impedance at the center of the antenna will now be approximately 72 ohms, permitting a convenient match to a 72 ohm transmission line.

The 72 ohm figure holds only for the resonant condition, when the signal frequency is such that the wavelength of the radio wave is twice that of the antenna, or when the antenna is a $\frac{1}{2}$ wavelength.

Above or below this resonant frequency, the center impedance of the antenna is a capacitive or inductive reactance, as any resonant circuit, and there is not an impedance match to the input of the transmission line. When this happens, there is a loss of efficiency.

The transmission line has the job of conveying the signal power from the antenna to the input circuit of the set. For minimum losses, the line should be as short as possible.

The impedance mismatch at the center of a dipole antenna can be reduced over a wider frequency range by using a folded dipole. This sort of antenna is shown in Fig. 4, as compared to the ordinary dipole in Fig. 3. The folded dipole is somewhat similar in appearance to an ordinary dipole and is really two dipoles in series. The center impedance is 2 squared or 4 times the

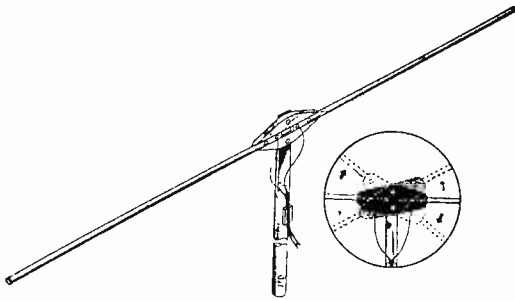

Courtesy of J.F.D. MFG. CO.

Fig. 3. Single element dipole antenna for the 44 to 88 Mc. band of frequencies.

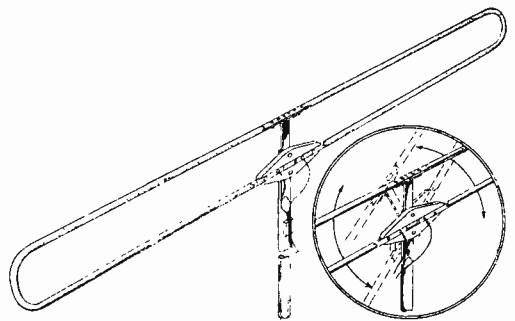

Courtesy of J.F.D. MFG. CO.

Fig. 4. Folded dipole—44 to 108 Mc. and TV channels 1 thru 6. For areas where reception is not up to maximum strength and where it is desired to get broad band response.

impedance of a $\frac{1}{2}$ wave dipole or $4 \times 72 = 288 = 300$ ohms approximately. This figure permits a convenient match to a high-efficiency, low-loss transmission line of the 300 ohm type. This line has the appearance of a flat ribbon, consisting of two conductors, insulated, forming the edges of the ribbon strip and insulation between the conductors.

To secure greater gain and directivity, where weak signals and undesired reflections are a problem, a dipole with reflector or a folded dipole with reflector, may be used. Antennas of this kind are shown in Fig. 5 and Fig. 6. When the signal has been picked up, some means of conveying it to the receiver is required. The usual method is to use an r.f. transmission line.

Transmission Lines

If we take an ordinary horizontal antenna and

run a single wire from a point on the antenna to the set, as in Fig. 7, the earth will form one part of the transmission path and we will have an unbalanced, crude form of transmission line. Further an impedance match can only be obtained at a single frequency and the operation of the antenna system is very critical on V.H.F. Every inch of the vertical line may pick up interference.

Using a two wire line, as in Fig. 8, we secure much better efficiency and reduced noise pickup. This line may be an open type separated by air insulation and supported at regular intervals by insulators. However, it's difficult to install if an open wire type. The parallel line supported by insulation is more commonly used and is available in standard impedances of 72, 100, 150 and 300 ohms.

The surge impedance of the line is the square root of the L/C ratio, where L is the inductance

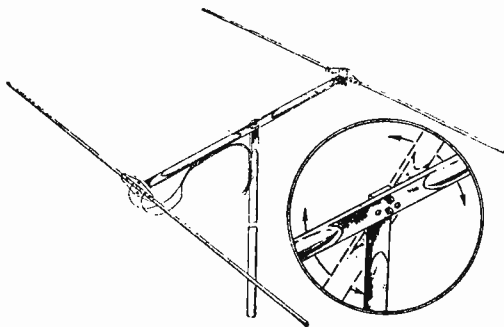

Courtesy of J.F.D. MFG. CO.

Fig. 5. Dipole with reflector—44-108 Mc. and TV channels 1 thru 6. For areas where a good signal is available but directivity is necessary because of noise conditions or ghost effects.

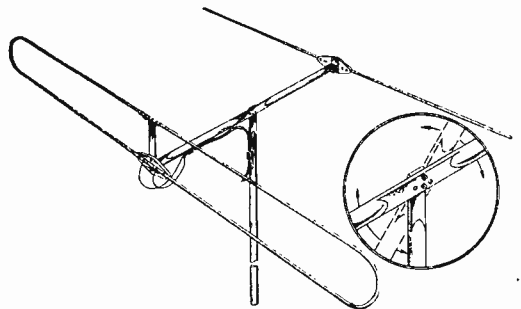

Courtesy of J.F.D. MFG. CO.

Fig. 6. Folded dipole with reflector—44-108 Mc. and TV channels 1 thru 6. For areas where maximum signal is not obtainable and where directivity is necessary because of noise conditions. Elimination of ghost effects and broad band are obtained with this array.

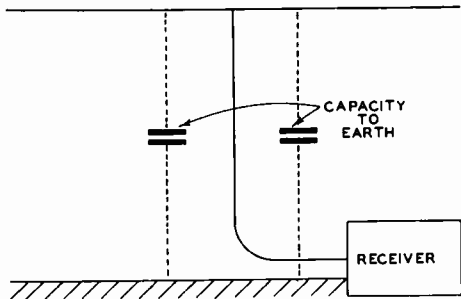

Fig. 7.

per unit length and C the capacitance per unit length of line.

As the conductors are brought closer together, the capacitance is increased and the surge impedance is reduced. Moving the conductors further apart, the capacitance is reduced and the line impedance (Z) rises. Therefore, when you examine transmission lines you will find that the high Z lines have wide spacing between conductors and the low Z lines have conductors close to each other. The high Z line carries a smaller current for an equal amount of power in comparison with the low Z type since $I = E/Z$. As the conductor losses are $P = I^2 R$, the use of a higher impedance permits thinner conductors which can be handled with greater ease than bulky, heavy cable.

As the conductors are spaced a greater distance apart, however, line balance becomes more critical. Phase differences may exist as a radio wave cuts across the line. This is shown in Fig. 8. Keeping the spacing small in comparison with a $\frac{1}{2}$ wavelength, therefore, is important.

Further, as the signal line current is reduced the signal/noise current ratio is reduced and there is a practical limit to the line Z value for this reason. As a matter of fact, in some critical installations it may be necessary to go to a low Z line to minimize the effects of interference.

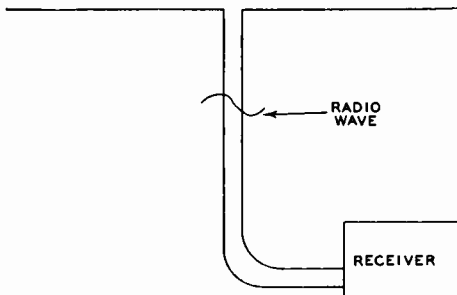

Fig. 8.

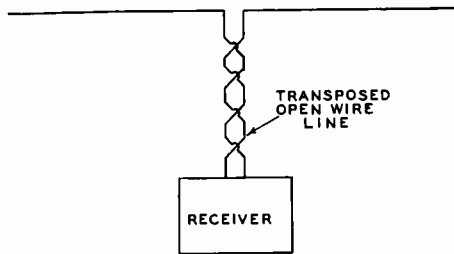

Fig. 9.

The Transposed Line

We have mentioned unbalance in the line due to the phase difference characteristic. By transposition, the effect can be made negligible. This is shown in Fig. 9. At one time such antenna lines were used widely by amateurs but due to the difficulty of construction and installation they have lost much of their popularity. Special transposition blocks were required.

A simpler means of getting the same effect, with a low Z cable, is to use a twisted pair line separated by material insulation instead of air. This is shown in Fig. 10. The cable is flexible, easily handled and easily installed.

Using the modern 300 ohm ribbon line, a similar effect may be gained by using a twisting action and turning the line something like a corkscrew, as shown in Fig. 11. About one turn per foot is recommended.

The co-axial type of line is relatively expensive but has the great virtues of low noise pickup and high efficiency. This type of line is not available in high Z values. It is shown in Fig. 12. It is flexible and easily installed.

If a 300 ohm dipole is to be matched to a 100 ohm co-axial line and a 300 ohm receiver input circuit, the arrangement shown in Fig. 13 may

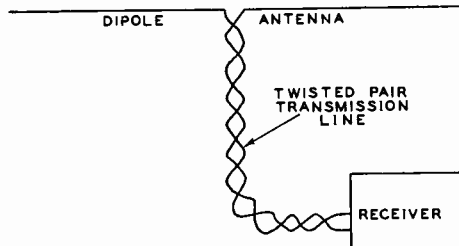

Fig. 10.

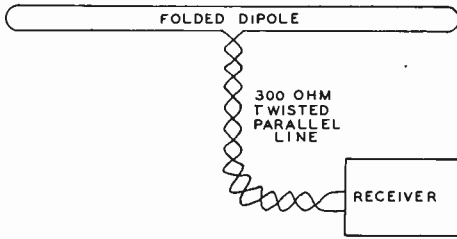

Fig. 11.

be used. However, because of the losses in the resistors, this antenna system should be used only where the field strengths of the stations are relatively high.

An alternative arrangement that may be used with fair success is illustrated in Fig. 14. The center Z of the antenna, 300 ohms, is matched approximately by the two lines since $2 \times 100 = 200$. If 150 ohm co-axial cable is used, a closer match, $2 \times 150 = 300$, is obtained. (Impedances that are resistive and in series are additive in value.) Such a line system will have less noise pickup than an ordinary high Z line.

We have reviewed some of the fundamentals of antenna and transmission line operation. We may now consider some of the practical aspects of FM and TV installation work.

INSTALLATIONS

Installations may be divided into two principal classes: home and business. The home installation is made for a single set. The business installation, for a radio dealer, may involve several sets or, if in some public place, such as a tavern, may require only one set.

The home may be in a suburban area and private or apartment house, or it may be in a city district where high level interference is troublesome. Each location has its own special prob-

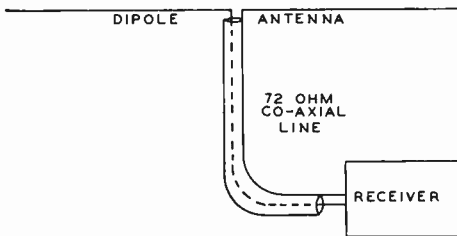
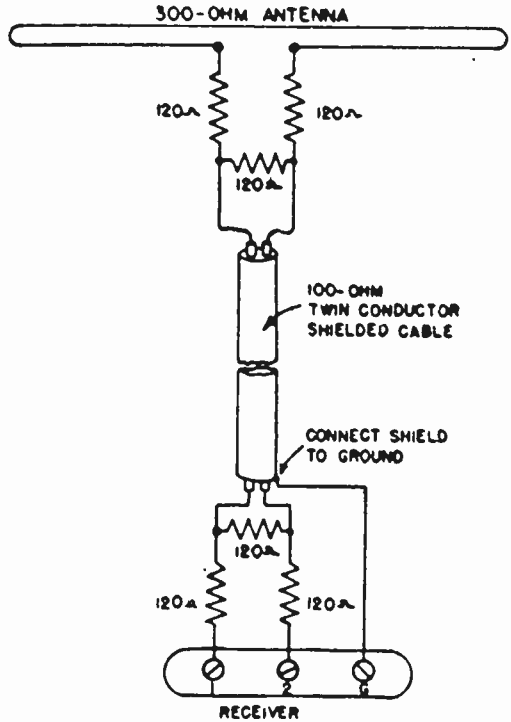

Fig. 12.



Courtesy of SERVICE Magazine

Fig. 13. TV Receiver connections for 100 ohm shielded cable.

lems that must be individually met and overcome.

FM Antennas

In some cases, the FM receiver will function fairly well with nothing more for signal pickup than its own built-in loop. However, this is the exception rather than the rule and to secure really good, noise-free and distortion-free reception, a good outside antenna is a necessity. Usually, the $\frac{1}{2}$ wave dipole will do the job.

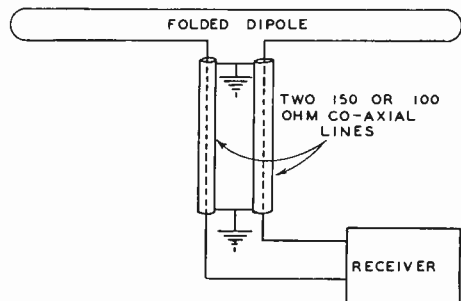

Fig. 14.

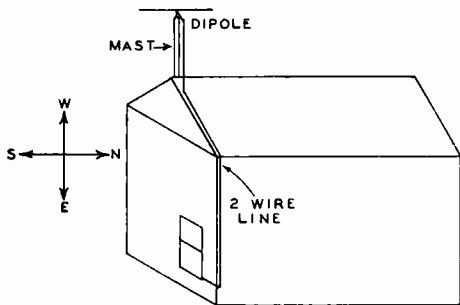

Fig. 15.

The first step in doing the work is to survey the location. The length of transmission line should be kept to a minimum for low losses. If the transmitter is in an East or West direction away from the receiver location, run the horizontal pickup element, the dipole, North and South as the best pickup is broadside to the antenna.

Auto ignition interference may be troublesome, so strive for height. In Fig. 15, the dipole is located near the front of the house and the transmission line is run at right angles to the horizontal element for at least $\frac{1}{4}$ of the length of the dipole. The pickup in Fig. 15 is for East and West. Using a small pocket compass and a map of the city, the work will be facilitated but experimenting with different antenna positions is the usual procedure.

If we wish we may substitute the folded dipole for the single $\frac{1}{2}$ wave element and get somewhat better signal pickup and efficiency. To increase the directivity, a dipole or folded dipole with reflector may be used. A top view is shown in Fig. 16. The maximum pickup is from the West. An unidirectional antenna of this kind would be helpful in eliminating noise signals from the East, or out of phase FM waves arriving from that direction which might cause distortion and weak reception.

The reflector is a wire or rod about 10% longer than the dipole and about $\frac{1}{4}$ wave behind it. A director is about 90% of the length of the dipole and $\frac{1}{4}$ wave in front of the dipole. For increased gain and directivity in critical locations and a uni-directional pickup pattern, we may use a multi-element antenna system employing the director, dipole, and reflector. An antenna of this description is shown in Fig. 17.

If we wanted the maximum pickup from the East, we would simply rotate the entire system 180 degrees so that the director would be facing East.

The transmission line may be held to the side of the house with suitable stand-off insulators. The

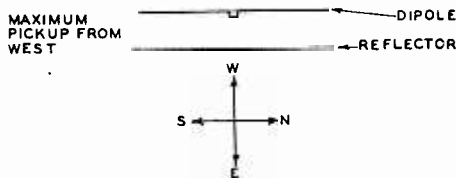

Fig. 16.

line should not be allowed to swing and sway too much in the wind if noise and poor reception are to be avoided.

As the commercial antennas are furnished with detailed assembly and mounting instructions, accompanied by drawings or photographs, we don't feel the need to go into these details here.

In an office building or apartment house in a city, the same general principles would apply. The antenna pickup element must have the proper geographical location, must be horizontal, and as high above the roof as possible. Keep this element away from metal objects or other antennas which would distort the directivity pattern of the antenna system.

TV Antennas

What has been said with respect to FM antennas applies in double measure to the TV antenna system. The same general principles are used but the TV antenna is far more critical. One reason is that TV video transmission is by amplitude modulation although the sound is FM. The sight program signals, therefore, are particularly susceptible to noise interference and to secure good pictures strong signals are essential. In many cases, where a simple dipole antenna would suffice for FM, the television set may require the more elaborate antenna array consisting of a dipole with reflector or dipole with director and reflector. So-called stacked arrays, consisting of a pair of dipole elements, with corresponding directors and reflectors may be used for longer than normal distance pickup or in particularly difficult locations where an ordinary antenna system would fail to do the job.

TV Installations

The television installation work may be relatively simple and easy or complex and difficult, according to receiving conditions and the location of the antenna with respect to the transmitter location. Usually, good results can be expected under line-of-sight conditions. The maximum distance is approximately shown by this formula:

$$d = 1.23 (\sqrt{H_T} + \sqrt{H_R})$$

where d =miles

H_T =height of the transmitting antenna

H_R =height of the receiving antenna

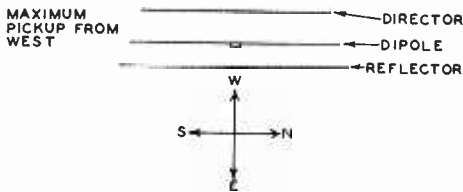

Fig. 17.

However, an approximate graph which eliminates the need for calculations is shown in Fig. 18. The distance in miles is shown at the base and elevation of the transmitting antenna in the left column. For a height of 200 ft., a range of 20 miles is obtained, etc.

While the receiving and transmitting antenna heights are not correlated, the graph gives a simple picture of range as related to height. Moreover, the transmitting antenna is usually higher than the receiving antenna.

Suburban Jobs

The suburban installation is characterized by two important factors: (1) distance from the transmitter; (2) relative freedom from ghosts due to reflections of adjacent antennas, tall buildings or metal structures.

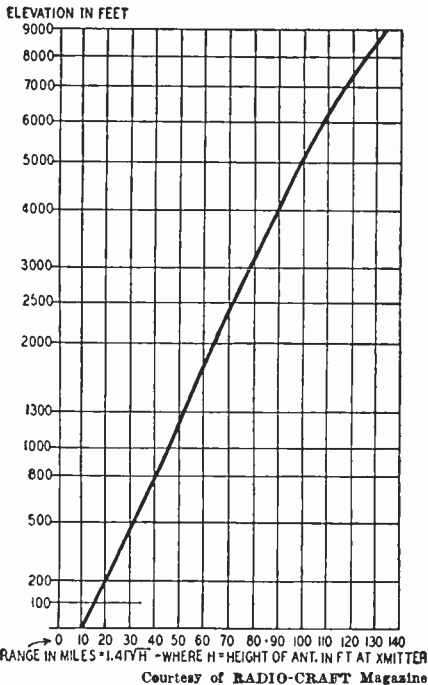

Fig. 18. Chart shows range versus antenna height.

The first of these factors influences field strength at the television receiving antenna. However, if the transmitter power is adequate for good service this factor is minimized. Usually, a half-wave dipole will be satisfactory. Its length should be at right angles to the direction of the transmitter and to find the correct position a map of the city and surrounding country may be used. A compass will be helpful in determining directions. If the transmitter lies east or west of the receiver, point the antenna north and south. If the transmitter is north or south of the receiver, point the antenna east and west. To get good results, directions should be determined accurately.

As a final check, assuming a TVA station is on the air at the time the installation is made, experimentally adjust the antenna for maximum signal strength as shown by increased clarity of the picture on the television receiver screen.

To get maximum pickup, strive for height of the receiving antenna. A special mounting arrangement such as that shown in Fig. 19, the SHUR Antenna Mount, would be particularly advantageous.

The half-wave dipole may be perfectly all right for reception from a single TV station operating at the resonant frequency of the antenna and for reception on channels near this resonant frequency (See Fig. 1) but where multi-channel operation and broad band response are desired, the folded dipole is better. Further, as this type has a center impedance of 300 ohms, it matches standard 300 ohm transmission line cable which is convenient to handle, relatively inexpensive and easy to install.

When a dipole is used and the receiver has a 300 ohm input, a quarter-wave line may be used

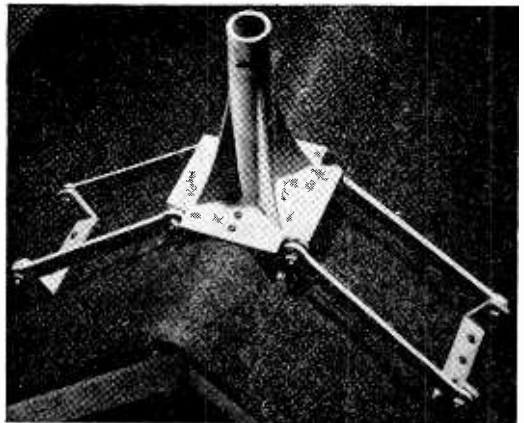

Courtesy of SHUR-ANTENNA MOUNT, Inc.
Fig. 19.

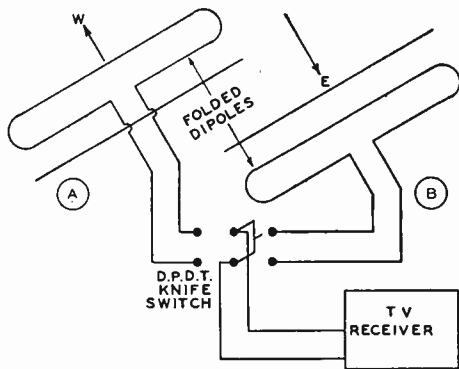

Fig. 20.

to get an impedance match but the theory involved is a little complicated and will not be given here. It is covered in the NRI Course. Antenna manufacturers also offer this information in data sheets distributors can supply.

The average, busy serviceman, however, has no time nor inclination to reach for a slide rule and do a lot of fussing with formulas and antenna matching schemes and adjustments.

Fortunately, TV antennas to meet every antenna situation likely to be encountered can be purchased due to the wide variety of the manufactured products.

Where, in the suburban area, the field strength is not high enough to give good results using an ordinary dipole, or folded dipole, either of these antennas fitted with a reflector or combination of director and reflector may be used.

The dipole with reflector is shown in Fig. 5 and the folded dipole with reflector in Fig. 6. The antenna, in any event, should be chosen to cover the channels of interest to the TV set owner.

When a reflector is used the antenna pattern becomes unidirectional. If the antenna could be rotated by special machinery under the control of the set operator, the direction of maximum pickup could be changed at will, but this method would cost a great amount of money and it is not used in practical TV installations.

Instead, an alternative technique is to use two such antennas and two transmission lines. This is shown in Fig. 20. Antenna A picks up signals from the west, B from the east. If two ordinary folded dipoles or simple half-wave dipoles are used, one may be pointed north and south, the other east and west to obtain a multidirectional effect, or may be oriented in any other desired manner.

When the antenna lead is brought into the home, ordinary window strip connectors should not be

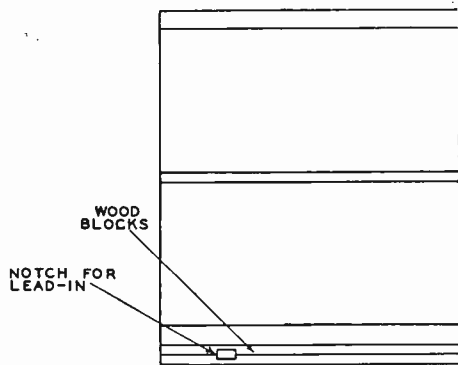

Fig. 21.

used. It would be possible to make up a small block of wood as shown in Fig. 21, consisting of two pieces which lift apart with a space to pass through the cable. Merely clamping down on the cable as it comes over the sill would be very poor practice.

A method of mounting a lightning arrester is shown in Fig. 22. The cable is split with a sharp knife and pulled apart for a few inches. The insulation is removed at the contact points and the necessary connections then are made.

When the antenna center impedance is 75 ohms, as it is for a half-wave type, and the line is a 300 ohm type such as shown in Fig. 22, a $\frac{1}{4}$ wave line may be used to get an impedance match. The surge impedance of this line is $Z = \sqrt{Z_1 Z_2}$ where $Z_1 = 75$ ohms, $Z_2 = 300$ ohms. Then, $Z = 150$ ohms approximately. A piece of 150 ohm coaxial cable or an equivalent line could be used to get the match. This is shown in Fig. 23.

We have considered suburban problems and now may turn our attention to the more complex and difficult city installations.

City Installations

Installations of TV antennas in cities are characterized by the following important factors:

1. High field strengths and multiple reflections or "ghosts."
2. Proximity of the TV antenna to other antennas and metal structures with attendant distortion of antenna pickup patterns and loss of signal strength.
3. Difficulty of installation and use of long transmission lines due to nature of the installation with resultant losses that may necessitate using high gain arrays.
4. Blocking of the line-of-sight path and consequent dependence upon echo or reflection signals for reception.

The high field strength is a distinct advantage in securing good pictures in areas where high noise

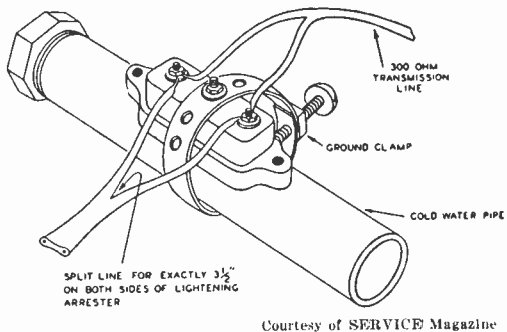

Courtesy of SERVICE Magazine

Fig. 22.

levels prevail. In cities, elevated railways, automobiles, electric motors, medical equipment and many other sources interfere with television reception. A better than average TV antenna is a necessity in such circumstances.

An antenna of this kind, a high gain type, is the Amphenol Folded Dipole-Model 114-005 shown in Fig. 24. This antenna is a highly directional type and covers the 54-88 mc. and 174-216 mc. ranges. Its application is particularly useful both in areas of low signal strength where its added gain results in a brighter picture and in areas of high signal strength where its highly directional pattern eliminates "ghosts" due to multipath pick-up. It is supplied with a 5 foot mast, mounting bracket, guy clamp, and 75 feet of Amphenol No. 14-056 300 ohm low-loss Twin-Lead transmission line cable. This impedance value matches the input impedance of most television receivers.

Ghost images are the result of reflected signals (See Fig. 2) arriving from directions which differ from that of the direct signal of the transmitter. Their appearance on the picture tube is due to insufficient directivity of the antenna.

The Amphenol Model 114-005 television antenna consists of two broad-banded folded dipoles and reflectors with a common transmission line. The unique design of this antenna permits the large folded dipole to be used also as a reflector for the small folded dipole on the 174-216 megacycle band. The antenna is designed to provide a good impedance match over the entire frequency range without the use of fre-

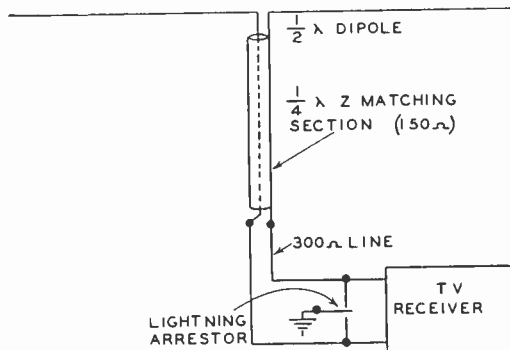

Fig. 23.

quency sensitive matching transformers.

The pick-up patterns are substantially unidirectional, and maintain the high front-to-back and front-to-side ratios over the entire band. Thus, this antenna design will eliminate the need of individual antennas cut for each channel or band.

The antenna elements and supports are ruggedly constructed of aluminum tubing and aluminum alloy castings, while the 5 foot mast is of steel tubing. This design is such that it will withstand high winds and ice loading. It is easily assembled with ordinary tools and is supplied with guy clamp and mounting flange. All points are at d.c. ground potential and lightning protection is ob-



Courtesy of RADIO-CRAFT Magazine

One ghost signal causes objectionable picture distortion.



Courtesy of RADIO-CRAFT Magazine

Two ghost signals cause serious picture distortion.

tained by grounding the mast.

The swivel mounting plate and guy clamp permit installation on practically every type of roof. The 5 foot mast permits installation of the antenna well in the clear to prevent distortion of the pick-up pattern by the close presence of surrounding objects. Since it is essential for line balance to keep the transmission lines spaced from the supporting mast, the antenna is supplied with two Amphenol number 66-909 stand-off insulators. Additional stand-off insulators are furnished to support the transmission line from the mast to the receiver.

General Procedures

Usually, the folded dipole with reflector will be satisfactory. However, its installation may require some careful work and in certain cases a more elaborate antenna will be necessary.

When difficulties are encountered, this does not necessarily mean that an elaborate type of receiving antenna must be substituted for the simple variety immediately, because in many cases the existing antenna is improperly sited, improperly oriented, or both, and further testing of antenna positions, experimentally, may correct the trouble.

Elimination of Ghosts

The first logical step in eliminating ghost reception is to make certain that the existing antenna is sited and oriented to obtain the best possible

reception at the particular location. At least two technicians, or servicemen, are needed to make a satisfactory television installation.

The following standard procedure is used to site and orient properly any type of television antenna. One man, holding a pole upon which is mounted the antenna, is located on the roof of the house or building. The portable antenna is connected to the television receiver by a lead-in which is loose and long enough to reach any location on the roof. A second man is located at the picture tube of the receiver to observe comparative signal strengths of the direct image and any ghost images. Some means of direct communication, such as Navy type sound powered telephones, or an intercommunicator, is used between the two men. *Tests are conducted while the desired television station is on the air.*

With the antenna held horizontally and broadside to the direction of the station, the man on the roof explores various possible antenna sites, while the observer at the set notes comparative signal strengths for each of the various roof locations.

If two television stations are to be received with the same antenna, the entire procedure is duplicated for each station and a suitable average or compromise location is selected as the best site for two-channel reception. A similar process is used for three and four channel reception. Elaborate work of this kind, of course, is done only at extra expense which must be borne by the customer.

However, antennas designed for multi-channel operation, such as folded dipoles, are susceptible to ghosts, since they lack sufficient directivity.

When the best site has been determined, the antenna is temporarily mounted so that it can be rotated. Again, using the two man coordination system, the antenna is revolved while changes in the received image are observed at the image tube. These effects are reported by the observer to the antenna installer by means of an intercommunicator or telephone system. Some ghost effects will disappear and reappear as the antenna is rotated. The object of this search is to locate a bearing position of the antenna which provides maximum strength for the direct wave, and the least interference due to

Wave reflections. At such a bearing position, the antenna is fixed in place and is then considered to be properly sited and oriented. For multi-station pickup, a compromise may be necessary or two separate antennas may be required.

Usually, but not always, objectionable ghost effects are greatly minimized or completely eliminated by the above procedure.

If, with the antenna properly installed and with all other components of the system functioning normally, ghosts still appear on the television screen, a more directional antenna is required for ghost-free reception.

Ghost effects are unwanted for normal television reception but the consistent appearance of ghosts on the picture screen during the installation can be utilized to good advantage, since the images provide considerable information concerning the nature and origin of the reflected waves. This information is obtained directly from the picture tube of the set, without additional analyzing equipment. (Experience is largely necessary to interpret properly the observed images.) Once determined, the information is used in selecting the proper type of directional antenna to block or eliminate the ghost signals.

When the direct image and the reflected image are well separated on the picture screen, we have an indication of signals converging at the antenna from two widely different directions. The unwanted signal usually can be eliminated effectively using an antenna of slightly increased directivity.

If the direct image and reflected image are displaced by a slight amount, or are so close together they cause a blurry effect, the indication is the out-of-phase signals are arriving at the antenna from almost the same direction, and an extremely directional antenna will then be required to separate the desired from the undesired signals.

When the intensity of the ghost image is weak in comparison with the direct image, the reflected signal is more easily blocked with a simple directional antenna. *When the intensity of the ghost image is stronger than the direct image it is sometimes possible to orient the antenna with respect to the reflected signal—rather than the direct signal—if the direct signal can be blocked satisfactorily so as to prevent interference with the desired (reflected) signal.*

By turning or rotating the antenna at the roof site while observing the comparative strength or intensity of the direct and reflected images,

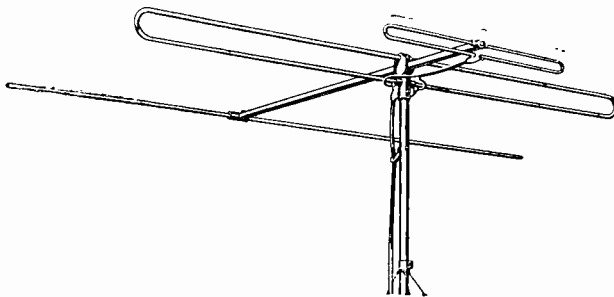

Courtesy of AMERICAN PHENOLIC CORP.

Fig. 24. Folded dipole television antenna.

it is often possible to identify the true bearing or direction of the source of the reflected waves—such as buildings, tanks, etc. When the source of trouble is known, it is often easier to deal with its effects. This and other information can be determined directly from the picture tube, regardless of the type of antenna, provided the antenna has been properly sited according to the general installation procedure.

When a more directional antenna is required for ghost-free reception, this previously determined site may prove adequate for the new antenna as well. However, this roof location is not necessarily the best site for all types of television antennas.

There is no ideal antenna suitable for all kinds of television installations because of the specific directional requirements of the individual nature of each location. In general the best antenna is the simplest and most economical antenna which provides ghost-free reception for a particular location.

It is conventional practice to use the light-weight dipole as the initial step in all new television installations. Later, if necessary, the special types of antennas may be installed.

Your own personal experience, obtained in doing this work, will be your best guide in planning installations in your locality. Be sure to familiarize yourself with the locations of transmitters serving your area and to be wary of guaranteeing results until after your preliminary survey shows the results are in fact obtainable.

— n r i —

TV Production 118,029 Sets In First Quarter, 1948

Total 1947 Production	178,571
January, 1948	30,001
February, 1948	35,889
March, 1948	52,139
Total	296,600

Is NR News Reaching You in Good Shape?

The last three issues of NR NEWS were mailed with the addresses on the back cover. In other words, they were not inserted in envelopes. You probably wondered why we made the change.

The cost of envelopes, such as we used for mailing NR NEWS has gone up tremendously. In fact the cost is so high it is almost prohibitive to use envelopes for this purpose. In line with many other publishers we decided to mail NR NEWS without an envelope.

Occasionally a copy of the NEWS will be damaged, torn or badly soiled. That's to be expected, considering the thousands we mail. If you should get a copy in damaged condition we will gladly replace it upon request.

Please keep in mind that if we had our preference in the matter we most certainly would use envelopes. However, because of the paper shortage and high costs, these are times when we must resort to expedients of all kinds in order to meet new situations.

L. L. MENNE, *Editor*

— n r i —

Second Edition of "Reference Data For Radio Engineers" Now Available Through Publisher

NRI students, well advanced in the course, and graduates who want to design their own circuits will find much valuable information in *Reference Data for Radio Engineers*, a Radio handbook, including formulas for the practical design of radio equipment. This handbook should be of particular interest to NRI men interested in Communication circuits. The second edition is improved and expanded over the original. The only way to get this book is to send \$2 direct to the Federal Telephone and Radio Corporation, Publication Department, 67 Broad Street, New York 4, New York.

— n r i —

The Joy of Being Editor

Getting out this magazine is no picnic.
If we print jokes people say we are silly;
If we don't they say we are too serious;
If we clip things from other magazines
We are too lazy to write them ourselves;
If we don't we are too fond of our own stuff.
If we don't print contributions, we don't appreciate true genius;
If we do print them the magazine is filled with junk.

Page Fourteen

If we make a change in the other person's write-up we are too critical.
If we don't we are asleep.
Now like as not someone will say,
We swiped this from some other magazine—
WE DID.

— n r i —

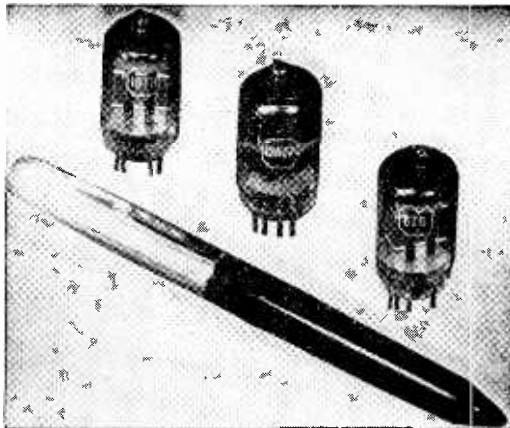

New G-E Miniature Receiving Tubes

Three new nine-pin miniature tubes, types 6T8, 19T8, and 12AT7, have been developed especially for FM and Television receivers.

These new miniatures are only seven-eighths of an inch wide and two and three-sixteenths inches high.

The 12AT7 is a twin triode, which can be used as a grounded-grid RF amplifier or as a converter at frequencies up to 300 mcs. A center-tapped heater permits either 6.3 volt or 12.6 volt heater supply. The 6T8 and 19T8 each contain three high-permeance diodes and a high-mu triode in one envelope. One diode has a separate cathode connection. These tubes are designed for use as combined AM and FM detectors and AF amplifiers.

Further information on the new tubes for FM and Television receivers may be obtained from the Tube Division, G-E Electronics Department, Schenectady, N. Y.

Note: Men contemplating the purchase of a tube tester will be interested in knowing that the new NRI Professional Tube Tester now has a test socket for testing these new type nine-prong miniature tubes. For more information write: L. L. Menne, Director Supply Division, NRI, 16th and U Sts., N. W., Washington 9, D. C.

SERVICING WIRE RECORDERS

By THEODORE WROBLEWSKI, Engineering Department Colonial Radio Corporation

Reprinted through the courtesy of "Sylvania News."

Wire recorders are becoming quite popular and we believe many of you will be getting service calls on them soon. This article by an engineer who has done considerable design work on wire recorders will give you confidence in working on any of these that come in for repair.

THE art of magnetic recording is approximately fifty years old. However, it took the recent war to add enough impetus to make the present home recorders possible.

A wire recorder consists basically of two units, one is the mechanical part which spools the wire from reel to reel, and the second is the electrical part which consists of the recording head and its associate amplifiers. In treating the subject, we will first review the "drive" or mechanism and then discuss the amplifier and recording head.

Several methods of spooling wire have been devised but in any system there are certain basic requirements. Some of these are as follows:

1. The wire must pass over the recording head at a uniform speed free from erratic or sudden changes.
2. The wire must pass over the play-back head at the same speed at which the record was made.
3. The wire must be under uniform tension.
4. The wire must be wound onto the spools and uniformly spaced with the turns side by side to allow it to unwind properly without snarling.
5. A method for rewinding the wire is required. In addition to the above, the system must include a method for stopping the spools at high rates of rewind speed without breaking the wire and an automatic stop must be provided to stop the machine when the wire comes to the end of the spool.

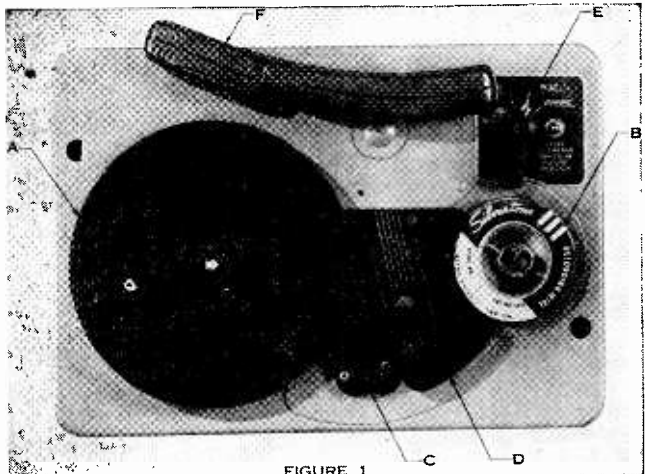

FIGURE 1

Courtesy of SYLVANIA NEWS

Several home-type recorders have recently been placed on the market, but this discussion will mainly deal with the model recently introduced by Sears Roebuck & Company.

Mechanical Features

Figure 1 is a top view of the mechanism. This consists of (a) a large spool (turntable) which has an inside groove diameter of approximately $5 \frac{13}{16}$ " (b) a supply spool (c) head (d) automatic switch (e) main control (f) tone arm. Turntable B diameter was chosen such that it turns 78 RPM in order to permit the user to have the additional feature of a record player. The supply spool is a band type of spool which presses onto the hub. The recording head oscillates up and down to level wind the wire on the take-up and supply spools. The automatic

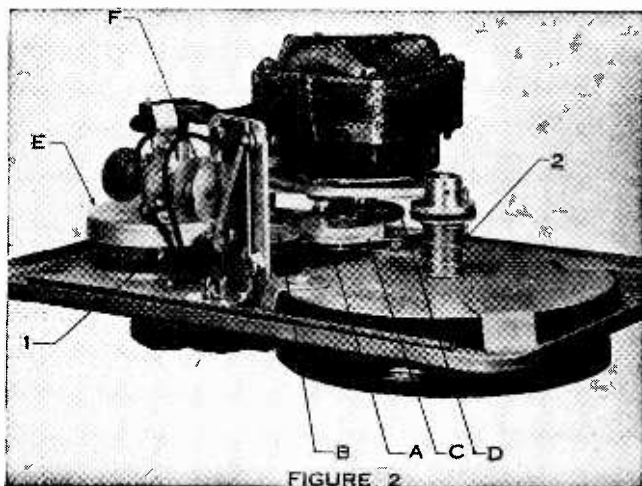

Courtesy of SYLVANIA NEWS

switch shuts the machine off when the wire comes to the end of the spool. The main control switch has four positions: (1) record, (2) play-back, (3) rewind, and (4) off. Tone arm as used for playing records.

Figure 2 is the bottom view of the mechanism. As can be seen from the pulley arrangement, the motor drives a pulley which in turn drives on the rim of the turntable similar to a record player. When the mechanism is switched to "off" or "playing," the idler (a) engages between the motor shaft and turntable thus acting as a brake. In going from rewind to stop or play, the springs (1) and (2) provide proper tension during the play or rewind to give proper winding onto the spool and tension as the wire passes over the head. Idlers b, c, and d engage drum, (e) in the rewind process. Item (f) is the level wind mechanism which is geared from the supply spool. This oscillates the head up and down to give the required number of turns of wire per layer onto the supply spool. The above description covers the basic mechanism. Naturally there will be variations of the parts from time to time. Other mechanisms are on the market which have other types of drives but the problems are quite similar.

The Play-Back Head

The heart of a wire recorder perhaps is the magnetic recording and play-back head. This consists of two coils which can be wound on separate laminations or on a common one as shown in Figure 3. The functions of these coils are: (1) Brase coil to provide enough energy to erase a signal on the wire, and provide the proper supersonic bias for proper recording. The bias is primarily used to raise the recording head

to a linear portion of the wire hysteresis curve. (2) The record coil provides the required magnetization which is impressed onto the wire. For play-back the record coil is generally used to pick up the signal from the wire. Essentially, in recording, the varying input signal varies the amount of magnetization on the wire. This variation of magnetization of the wire in play-back induces voltage in the play-back coil which in turn is amplified and provides the necessary signal for listening. As shown in Figure 3, when the wire passes over the erase or record coil it passes over a small gap. The wire effectively short circuits the magnetic circuit and is thus magnetized in the process. In general, the erase gap is on the order of five to ten times as great as the record gap. The gap distance for the record circuit is approximately one to two mils. (.001"—.002").

The gap width in the record coil determines the frequency response for the head and wire. Generally speaking, a larger gap gives more lows but less highs, therefore, an optimum value is generally picked.

Response Curves

If proper bias is applied to the recording head and the head is connected to an amplifier which has a flat response and a constant current signal source is used, the play-back voltage will look as in Figure 4A. It will be observed that the response curve as shown is lacking in "lows" and "highs." As a result it is necessary to emphasize the "lows" and "highs" in either the record process or play-back process, or both. A common method is to emphasize on record so that the record amplifier has a response curve as shown in Figure 4B. Combining the two curves the result is shown in overall response curve in Figure 4C. This final response curve is that which is required for good listening. The overall response curve in play-back can be varied by conventional methods of boosting the highs or lows as desired.

The wire used for recording on a Sears recorder is a stainless steel wire with a .004" diameter. It passes over the head during the record and play-back process at approximately 2' per second. The wire, if broken, can be tied together with a square knot and the loose ends trimmed off with an ordinary pair of scissors. A knot will pass over the head without any trouble.

Servicing Suggestions

In servicing wire recorders of any type, several

simple points should be checked which we will list as follows:

A. Mechanical.

1. No loose parts.
2. No varying friction or "drag" in the mechanism to make the wire tension change.
3. All adjustments set so that no loose windings develop and the wire is properly wound.
4. Brakes set properly.
- 5 Head oscillates to wind the wire uniformly.

B. Electrical.

- 1.No opens or shorts in the recording head.
2. Check bias for frequency and voltage.
3. Check recording current.
4. Check rest of amplifier in normal way.
5. Make sure the wire rests properly in the groove of the recording hand.

It is impractical here to give recording currents and bias voltage because there are so many different heads available and in use. The same is true for bias frequency although this is generally between 25 and 40 Kc.

In recording on wire normal recording precautions common to all types of recording must be followed, such as microphone placement, acoustics, monitoring for proper level. One of the things to watch in wire recording is not to overload the wire, that is, to make sure your recording level is properly adjusted. If too much signal is impressed on the wire, it will sound distorted at play-back and it will be difficult to erase the wire completely. Incomplete erasure will have a signal in the background which will be noticeable on subsequent recordings, especially on soft passages. This will sound similar to an interfering distant radio station on the same band in an ordinary home radio. Oftentimes several passages of the wire over the erase head will completely erase even an over-recorded signal. In most wire recorders erasing is accomplished while recording. The wire passes over the erase head first and is prepared for recording so it is possible to record right over a previous recording. In order to erase a portion of a recording

RECORD AND PLAY BACK HEAD

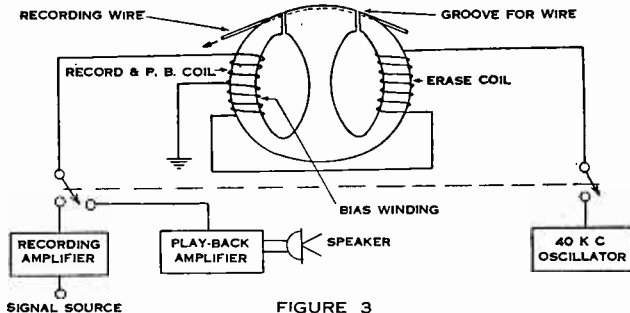

FIGURE 3

Courtesy of SYLVANIA NEWS

simply turn the input signal control to zero (0) and record. This will automatically erase without recording.

In magnetic recordings it is also important to get enough signal on the wire because the output of the play-back head is on the order of one (1) millivolt for normal recording. Unless enough signal is available a very high gain amplifier will be necessary. In some cases enough level will

FIGURE 4

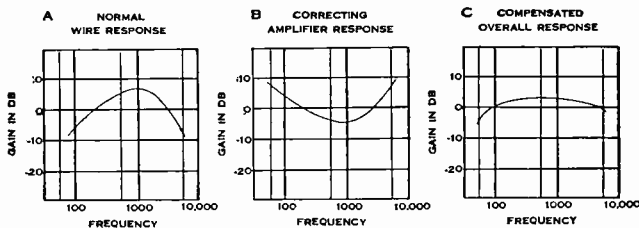

Courtesy of SYLVANIA NEWS

not be available with present recorders if the recorded signal is too low.

A wire recording may be kept and played back thousands of times without any increase in noise or loss in signal level. Also the number of new recordings on the same piece of wire is unlimited.

In handling a wire recorder, normal precautions must be followed and for "live" recordings proper microphone placement and room acoustics are essential. If simple precautions are followed, it is possible to attain a very high quality of recording on these simple devices known as wire recorders.

— n r i —

A recent survey indicates 65 Television stations to go on the air in 1948.

OUR COVER PHOTO

The Service Center of Graduate Roscoe J. Bailey

We are proud to hear of the achievement of Graduate Bailey. His story of constant progress and overcoming difficulties should prove an inspiration to all of us.



Graduate Roscoe J. Bailey.

Dear Mr. Smith:

At the age of nine years I had the misfortune of losing my left hand. Even so I often feel the misfortune is not so great as I find very few things that I cannot do. I attended Weston High School, where I was captain of their undefeated wrestling team. I won the title of Tri-State Champion of West Virginia, Maryland, Virginia and District of Columbia in 1934.

After graduation from high school I attended West Virginia Wesleyan College, Buckhannon, W. Va. I entered Glenville State Teachers College and received my degree in Physical Education and Public School Administration.

I then accepted the principalship of one of our city grade schools. From there I was sent to Weston High as head of the Physical Education Department in 1942. I decided I must find a hobby which would distract my mind from teaching during my hours away from school. All my life I have been interested in radios and experimented with them whenever the opportunity presented itself. At the outbreak of the war, I became interested in earnest and decided to make radio my hobby. I enrolled with the National Radio Institute and have always been glad that I did.

After finishing my course with NRI, I taught radio in the high school in addition to Physical Education. Radio was added to the curriculum to help prepare some of the boys for the service. I am proud to say many of them secured and held good positions in the signal corps.

At the close of the war I decided to enter the
Page Eighteen

radio repair business, since I was more interested in radio than in teaching. October 1, 1945, I opened my shop in one side of my garage. Within a year my business had grown so that I needed more room. On February 1, 1947, I opened for business in my present location.

Salesmen have told me I have the most attractive service center in West Virginia. Our service department brings in around \$3,000 per year. I do the service work myself and most of the time have a man in the field doing installation jobs. I am now preparing to take my FCC examination for first class Radio Telephone License. My hours away from my business are filled with taking care of the remote broadcast for our local station.

I am very proud of the reputation I have built in my dealings with the public and of the confidence people have in my judgment.

Of course I cannot take all the credit for my success. I owe a great deal to all the fine people, especially my Mother, who have influenced my life. Not merely for money have I determined to be successful, because the satisfaction of being a good cog in the great machinery of life cannot be counted in dollars and cents.

Thanks to the National Radio Institute for the splendid training I received. I can do fast, thorough, dependable radio repair.

Sincerely yours,
Roscoe J. Bailey,
Weston, West Virginia



J. B. Straughn

Developing the Ability To Diagnose Receiver Troubles

By J. B. STRAUGHN

NRI Supervisor of Training

JOHNNY JONES the service ham, grabbed his meters and worked them fine, He tested this and he tested that; the trimmers he failed to align. The time grew short, the Boss did snort: "What kind of a guy have I hired?" The end of the day brought one relief, for Johnny, poor fellow, was fired.

The ability to locate quickly the cause of trouble in a defective receiving set marks the difference between an expert serviceman and a screw-driver mechanic. Too many servicemen, fellows who have been in the field for years, still test each and every part in a defective receiver until the bad one has been found. Such men are lucky to complete three or four jobs a day, working steadily at the bench.

The expert approaches a defective receiver in an entirely different manner. He does not start out by blindly testing parts, nor is he tied down to one or two servicing techniques. He knows them all and chooses for each type of complaint the one which will give him useful information, the kind of information he needs to diagnose the trouble.

First, he considers the receiver which is to be repaired. Sets coming in for servicing may be divided into two classes; those which are dead (do not play), and those which play improperly, that is, they have distortion, hum, oscillation, are weak, intermittent, etc.

In the case of a dead receiver, it is first inspected for surface defects: to see if the tubes all light, if the antenna and ground connections are in-

tact, if smoke is coming from the chassis, if the tube top caps are in place, and if the speaker is plugged in. Should everything be apparently O.K. a circuit disturbance test is made, working back from the power tube to the input of the set. In ninety-nine times out of one hundred this will isolate the defective stage. From here on the procedure employed depends entirely upon the individual serviceman. After checking the condition of the tubes, he may measure the operating voltages of the dead stage, point to point, or he may check electrode circuits for continuity with an ohmmeter. I usually use an ohmmeter because in a dead receiver some part in a voltage supply circuit has generally broken down and may easily be located by checking between points which reveals useful information. A voltmeter could just as well be used, but after finding the electrode which lacks voltage it will be necessary to check the circuit with an ohmmeter anyway. Why waste time?



Using this method, a serviceman can locate the cause of trouble in the average dead receiver in ten minutes or so. Correction of the defect may take longer, depending on his skill with tools, the nature of the defect, and how cleverly the manufacturer has hidden the bad part away under shield cans, etc.

Naturally this does not complete the service job, for the rest of the tubes must be checked and the set operated for at least an hour to see if any other defects develop. If you work in a large shop an assistant can do this, even to the installation of the new part, making you, the expert, a sort of glorified diagnostician.

Perhaps all this sounds too easy and the time too short, but I know that most experts will agree that a dead receiver is "duck soup" to the serviceman. Let us spend a little time with a dead receiver.

Suppose that the typical AC-operated super-heterodyne (Figure 1) is dead, and to make matters easy let's suppose that condenser C_5 has broken down, burning out resistor R_2 . An inspection for surface defects reveals nothing so we start a circuit disturbance test.

We withdraw and replace tube VT_4 ; a click can be heard in the speaker. We touch the top cap of tube VT_3 (volume control all the way on during these tests); a shrill buzz is heard in the speaker showing that the set is alive from this point on. We touch the top cap of VT_2 ; this may not produce a click even if the stage is operating. If no click is heard, we remove and replace the top cap connector which causes a click if a signal can pass through the stage. We repeat this procedure on VT_1 .

Bearing in mind that C_5 and R_2 are defective, will a click be heard when the top cap of VT_1 tube is removed and replaced? Think hard, for this is the fact upon which our diagnosis is based. The answer is that a click will be heard, and this fact, coupled with lack of reception, points to oscillator failure.

I would look for causes of oscillator failure since ninety-nine times out of one hundred the diagnosis would be correct. The hundredth time a signal killing defect, such as an open antenna coil or shorted tuning condenser, will exist between the VT_1 input (top cap and cathode) and the signal source which is the antenna.

Now if you don't understand why this click on VT_1 comes through even with a dead oscillator you couldn't figure out the trouble. The reason follows: When there is a sudden change in current through a resonant circuit, oscillations are set up in the circuit at the resonant frequency. They only last momentarily, quickly dying out. The fact that the strength of the oscillations is not constant means that the signal produced in this manner is modulated, and when detected, can be heard. The technical name for this action is shock excitation.

When the top cap of VT_1 is removed and replaced, the plate current changes sharply and sets up a modulated I.F. signal in the I.F. amplifier which goes through the receiver circuits just like a program from a transmitter. The effect is comparable to that obtained when the output of an I.F. signal generator is fed in the input of VT_1 . It is worthy of note that

the defect in parts C_5 and R_2 , while removing voltage from the oscillator anode grid, does not prevent plate current from flowing. If it did, no click would be heard when removing and replacing the top cap of VT_1 , and the trouble would simply be isolated to the VT_1 and its associated circuits instead of to a particular circuit.

Since we have diagnosed the trouble as a dead oscillator, what shall we do now? We can verify the diagnosis, or we can check for causes of oscillator failure. Therefore, we must know how to check the oscillator. One infallible check for oscillation is to measure the d.c. voltage across R_1 with a high resistance voltmeter. No voltage—no oscillation.

We are satisfied that the oscillator doesn't work, so we look at the diagram. What makes the oscillator work? Here is the downfall of the screw-driver mechanic. He—sad to say—has no idea why or how the oscillator works; "it just do" and that's that! Shades of Marconi! If he doesn't know how or why it works, is it possible for him to determine why it won't work or what could stop it from working? No sir, it is not possible, so score one hundred points for a *theoretical* understanding of oscillators. Remember any kind of defect is possible in this circuit and we must have some idea of what we want to find. Look at the parts value. R_1 is supposed to be a 56,000-ohm resistor. We check it with an ohmmeter and find it to be 45,000 ohms. Have we found the trouble and shall we put in another resistor? No, because such a change in the value of the oscillator grid resistor will not make the oscillator dead. How do we know that? Ah, ha! Score one hundred for practical experience. I have changed the value of many oscillator grid resistors at one time or another just to see what would happen. If the value is too low, the oscillator stops completely; if almost too low, it stops at low frequencies (the set works on the high frequency end of the dial only) and if too high, the oscillator blocks, working intermittently and giving a chopped up reproduction on all stations.



Look again at the diagram and see what parts are most likely to break down. It is those parts that have a high voltage across them or that carry considerable current. These are the plate winding of L_3 , condenser C_5 , and resistor R_2 . Trouble in any of them would remove plate voltage from the oscillator and would most certainly stop it from working. If you wish, confirm your suspicion by measuring for voltage between socket terminal 4 of VT_1 and the chassis.

Lack of voltage shows the trouble and we now proceed to check its cause. We remove VT_1 , turn off the set, put one ohmmeter probe through

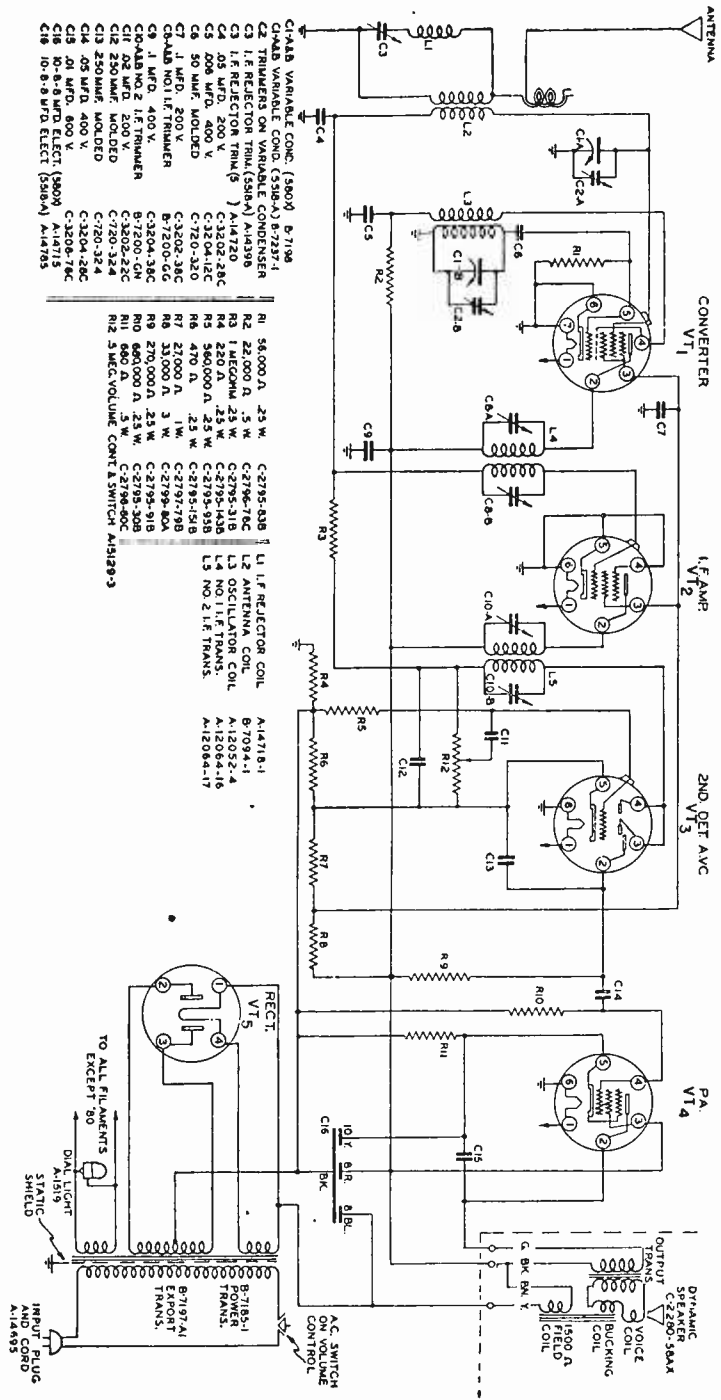

Fig. 1. Typical A.C. operated superheterodyne receiver.

socket hole 4, the other through hole 2. We should measure about 20,000 ohms, the approximate value of R_2 . L_3 is only a few ohms so its value won't register in comparison to that of R_2 . We don't get continuity so we know the circuit is open. The circuit disturbance test proved that there was voltage on socket terminal 2, placing the defect in either L_3 or R_2 . The resistor is checked first and we find it to be open, L_3 is checked, just in case, and it proves to be intact.

Should we immediately replace R_2 and turn on the set? The diagram shows the presence of C_5 and if it is broken down, R_2 would pass excess current and burn out so we first check C_5 , and, sure enough, it is broken down. We replace it and the job is done.

Wait a minute! The parts list calls for a 400-volt condenser and we don't have a 400-volt condenser. Well, we'll use a 600-volt condenser for it won't break down as easily as one rated at 400 volts. We check over our stock of parts and find many 600-volt condensers—.1 mfd., .05 mfd., and .01 mfd., but no .006 mfd.—what to do?

First, why is C_5 there anyway, and what is the theory of its operation? C_5 is a by-pass condenser and serves to keep the end of L_3 at R.F. ground potential. We realize that increasing the capacity of a condenser reduces its reactance and makes it a better bypass and therefore we know that increasing the capacity of C_5 will have no ill effects. We grab the .01 mfd. 600-volt condenser, the soldering iron, the resistor, and with a deft flip of the wrist complete the job and thus bring peace and music back to the home of our typical receiver.

The improperly playing receiver is a horse of another color. There is no easy and definite procedure which will show up the defect quickly. The expert, however, is not stumped. He will check a few definite parts, then lo and behold—he has the bad one in a relatively short time. When he checks a certain part he is not doing so aimlessly, neither is he playing a hunch. He has catalogued the defect by its symptoms and knows what parts or circuits in the receiver could cause such trouble. This does not mean he has had previous experience with the same trouble in that particular set. He is simply applying cause and effect reasoning. He knows what can and what can't cause the trouble so he checks possible causes in the order of their likelihood.

With improperly operating sets a schematic is useful. Simply look at the schematic and figure out the trouble, then locate the part and check it with instruments or by substitution.

If a receiver hums, study first of all the filter system on the schematic. If electrolytic condensers are used, check them, either by substitution or with an R-C Tester. Is the choke tuned; if so, what is the condition of its shunting condenser? Is a hum-bucking coil used in series with the voice coil and could the connections have been reversed? Your eyes should next swing to the electrode supply circuits of the tubes, to see if resistance-capacitance filters are employed; if present, check them. If the schematic shows the A.F. amplifier to have potentially high gain, try new tubes even though the present ones check O.K. as cathode to heater might not show up on the tube tester. Then you might see if the positions of the control grid leads have any effect on the hum by moving them around to different positions.

In an oscillating receiver your eyes will first be drawn to the by-pass and output filter condensers, then you might see a bleeder resistor which, if open, could increase the screen voltages to the point where oscillation could occur.



Does the set distort? If so, at high volume control setting or at low settings? If at low setting excessive bias on some tube is indicated while at a high setting the bias on some tube is too low. The schematic shows what could cause this so these points are checked first. You further know that distortion is due to some tube working off the straight part of

its curve; perhaps the plate voltage on the first A.F. is too low and if there is a resistive-capacitative filter you check the condenser for excess leakage. Sufficient leakage to lower the plate voltage of the tube to the point of distortion would not affect the other B voltages due to the series filter resistor, so you have to know what to check.

We are called in on a dead Sparton 601-B (Figure 2). An inspection for surface defects with the set turned on shows that the tubes and pilot lamp fail to light. On turning the set off, we could check with an ohmmeter each section of the series filament circuit, or we could test the tubes in a tube tester. Suppose we find that the section of the rectifier tube filament shunted by the pilot lamp, and the pilot lamp is burned out. In case of any other tube filament failure, we would just replace the tube and try the set. In this case, however, examine the diagram closely. We see that the lamp shunts part of the filament of the 35Z5GT. Also, the plate is connected to this filament tap, so plate current flows through the pilot light and filament section in addition to the filament current.

This accounts for the pilot light being bright when the set is first turned on, then getting

**SCHEMATIC DIAGRAM
SPARTON SUPERHETERODYNE MODEL 601-B
INTERMEDIATE FREQUENCY 456 K.C.**

R.F. CONVERTER 125K7GT
L.F. AMP 125K7GT
2ND DET & AVC 125Q7GT
P.A. 351L6GT

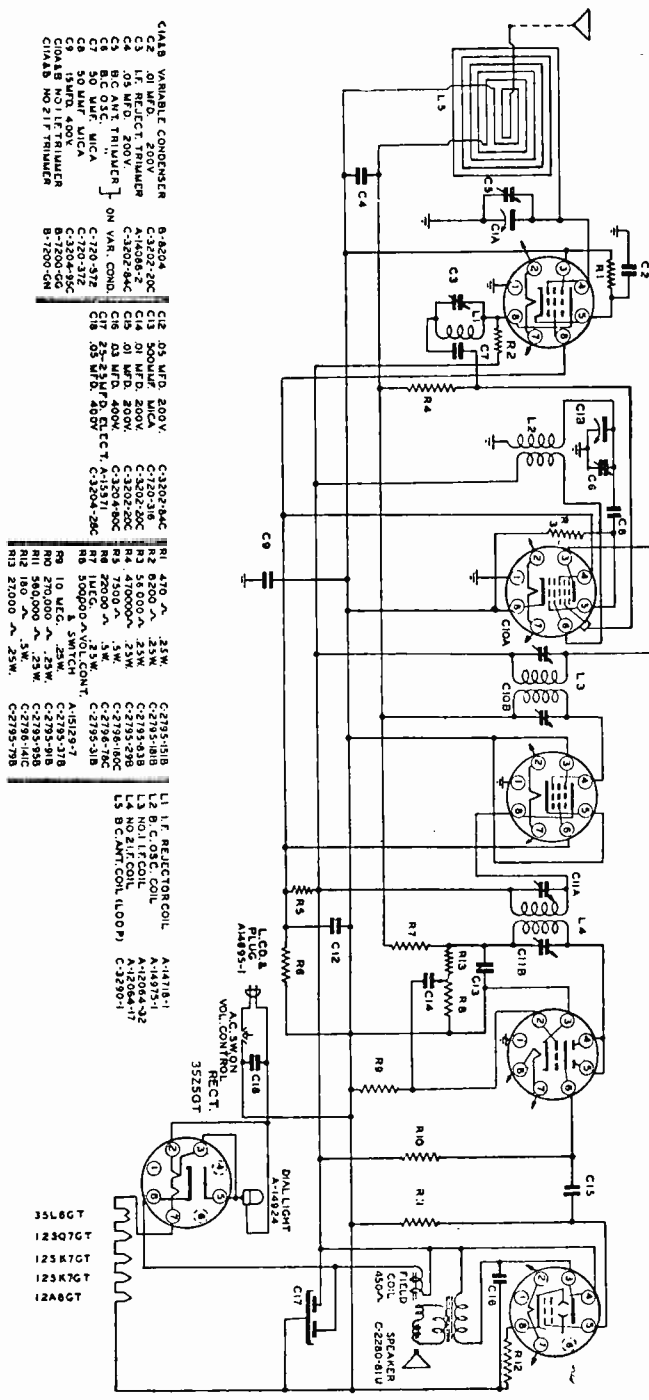

Fig. 2

- | | | | | | | | | | | | | |
|--------|------------------------|---------------|-----|----------------|------------|-----|-----------------|------------|------------|----|------------------------|------------|
| C1A15 | VARIABLE CONDENSER | B-8204 | C12 | .05 MFD. 200V. | C3202-84C | R1 | 470 Ω | .25W. | C2735-918 | L1 | H.F. REFLECTOR COIL | A-14178-1 |
| C2 | .01 MFD. 200V. | C-3202-20C | C13 | 500MUF. MICA | C120-716 | R2 | 820 Ω | .25W. | C2735-918 | L2 | H.F. REFLECTOR COIL | A-14178-1 |
| C3 | .05 MFD. 200V. | C-3202-84C | C14 | .01 MFD. 200V. | C-3202-20C | R3 | 150 Ω | .25W. | C2735-918 | L3 | H.F. REFLECTOR COIL | A-14178-1 |
| C4 | .05 MFD. 200V. | C-3202-84C | C15 | .01 MFD. 200V. | C-3202-20C | R4 | 41000 Ω | .25W. | C2735-918 | L4 | NO. 2 I.F. COIL | A-12064-32 |
| C5 | B.C. ANT. TRIPLIFIER } | ON VAR. COND. | C16 | .03 MFD. 400V. | C-3204-80C | R5 | 7500 Ω | .5W. | C2735-918 | L5 | B.C. ANT. COIL (L100P) | C-3290-1 |
| C6 | B.C. ANT. TRIPLIFIER } | ON VAR. COND. | C17 | .25 MFD. 400V. | A-1351-28C | R6 | 7500 Ω | .5W. | C2735-918 | | | |
| C7 | B.C. ANT. TRIPLIFIER } | ON VAR. COND. | C18 | .25 MFD. 400V. | A-1351-28C | R7 | 50000 Ω | VOL. CONT. | C2735-918 | | | |
| C8 | 30 MUF. MICA | C-320-37Z | | | | R8 | 2200 Ω | .5W. | C2735-918 | | | |
| C9 | 15 MFD. 400V. | C-3204-85C | | | | R9 | 10 MFD. 250V. | SWITCH | A-15128-17 | | | |
| C10A15 | NO. 2 I.F. TRIPLIFIER | C-3204-85C | | | | R10 | 270000 Ω | .25W. | C2735-918 | | | |
| C10A15 | NO. 2 I.F. TRIPLIFIER | C-3204-85C | | | | R11 | 580000 Ω | .25W. | C2735-918 | | | |
| C10A15 | NO. 2 I.F. TRIPLIFIER | C-3204-85C | | | | R12 | 180 Ω | .5W. | C2735-918 | | | |
| C10A15 | NO. 2 I.F. TRIPLIFIER | C-3204-85C | | | | R13 | 21000 Ω | .25W. | C2735-918 | | | |

dim and finally lighting normally when the set works properly. When the set starts, the tube filaments are cold and have low resistance. Fairly high current flows through the lamp making it quite bright. As the tubes heat up, the filament resistance increases allowing less current to pass through the lamp and dimming its light. When the tube filaments get hot the heat is transferred to the cathodes, they start emitting electrons and current is drawn from the rectifier. Hence, the plate current flow serves to bring the pilot light back to normal brilliancy.

If too much current is drawn from the rectifier this would cause the lamp and filament section to burn out. Do the tubes in the set do this? Possibly, if shorted, and we will remember to check for this later if we don't find the trouble elsewhere. The trouble could have been just a surge condition, or could be a short circuit in the B supply. The most likely reason is broken down filter condensers for they could cause excess drain on the rectifier and they are a probable weak point in any set, because they have a high voltage across them. Also, practical experience gained from observation of many receivers tells us this.

Before going to the trouble of locating the condensers and unsoldering their leads for an ohmmeter tester, let's make another test. Check the resistance across the output of the rectifier and see if it is normal. First, between what points shall we check? Between the rectifier cathode (terminal 8 of the tube socket) and the set side of the on-off switch. These points are readily located and the measurement made, an almost zero resistance reading showing the presence of a short. We then proceed to check the condensers, and finding the input section of C_{17} bad, we replace it.

Suppose on the other hand we obtain an ohmmeter reading of 30,000 ohms when making our test—is anything wrong? Look at the diagram and trace the path through which the ohmmeter current flows, adding up the resistance values. Starting at the cathode we go through the speaker field (450 ohms), R_5 (7500 ohms), and R_6 (22,000 ohms). This makes a total of about 30,000 ohms so nothing is wrong here and the filter condensers are not shorted. We therefore check the tubes and may find a short in the 35L-6GT which only shows up when the tube is hot as it is when checked in a tube tester. If we fail to find any trouble, it may have been the surge condition mentioned before. We must now replace the tube and pilot lamp to be sure. If everything is normal, we need not worry further as this surge condition is rare, being due to some power line voltage change at the moment the set was warming up in the home of the owner.

Now we are confronted with the toughest problem a serviceman must face. The A.C. Superheterodyne is intermittent (referring again to Fig. 1). We verify the complaint at the customer's home, carefully check his aerial-ground-lightning arrestor system and depart for the shop after assuring the customer we will phone him as soon as the trouble has been isolated.

At the shop we place the set in operation and make an inspection for surface defects, then connect a high resistance D.C. voltmeter across the diode load resistor (volume control R_{12}). The voltmeter will deflect an amount depending on the diode current of VT_3 . If the signal reaching VT_3 decreases it will be indicated on the meter. We let the set play and go about our other shop work and soon the intermittent occurs, the signal dropping to just a whisper.

On examining the voltmeter we find that its reading is just about the same as before, proving that the signal is still reaching the diode plates and is being rectified. The trouble therefore is between the volume control and the loudspeaker.



We concentrate on this section of the receiver, pulling on leads and wiggling parts to see if we can bring back the volume. In between wiggles and pulls the set suddenly snaps back by itself and before we can catch our breath it cuts off again!

We continue to pull and wiggle and through carelessness our long-nose pliers which we are using short the positive terminal of condenser C_{16} to the chassis. We jerk back the pliers and the set starts to play. Now what? Have we found the trouble? Is this condenser bad? The set cuts out again and we momentarily short the condenser, the set immediately coming back to life. Definitely we have found something, but what? Can we conceive of any kind of trouble in this condenser which would cause intermittent reception of this type? The condenser is in the B supply circuit of all the tubes and therefore it is not breaking down because this would make the stages ahead of VT_3 inoperative. We doubt if the condenser is opening up, but we check it by unsoldering its B+ lead. As we thought, the intermittent action is not affected.

It is obvious, however, that the sudden removal of B supply voltage has taken the stress off the defective part thus allowing it to heal itself. Let's look at the diagram and see which parts would most likely be affected. We can at once eliminate current supply parts since a defect in them would cause terrific noise and that is not the complaint. This leads us to the signal circuits and almost without hesitation to coupling condenser C_{14} . We

try wiggling this condenser and the set cuts off. Another wiggle and it comes back on. There is evidently a poor contact between one of the condenser lugs and the foil of which the condenser is wound. To complete the job we install another .05-mfd. condenser rated at 600 volts. The set is then played an hour or two just to be sure there isn't another intermittent part.

We have traced through the typical repair of an intermittent receiver. The part about shorting the filter condenser is *not* to be followed in jobs of this sort. It was introduced as being an accident because no serviceman would intentionally short the output of a receiver power pack. Such a short could damage other parts in the receiver. However, many servicemen have made such accidental shorts and have been puzzled and wasted time due to the effects we have described. You now know that it does not mean the part which was shorted was at fault and it could conceivably be in any of the A.F. signal circuits.

By this time you have a fair idea of the powers of deduction possessed by an expert. You perhaps wonder, "will I ever be like that?" and "can I ever learn to diagnose defective receivers?" The answer is YES both times and it will not be hard to gain this ability. Thousands of NRI men have it and they got it through diligent study of radio fundamentals (theory) and by gaining practical experience.

To be a service expert you must have theory, and for your theory to be of any value, you must know how to use it. To get your theory you must study your text books with the idea of understanding them. It is not enough to simply read the books and get the answers to the test questions. You should learn and understand something new each time you complete a study lesson. This also applies to your experimental outfits—profit from them by thinking about what you are doing. It is not enough blindly to make a specified change in a circuit and answer the report statement. Analyze in your own mind just what has occurred, in the circuit and the reason for the answer you make. Do all this and you are beginning to get somewhere.

Book learning *by itself* is not sufficient to give you this knowledge. Nowhere else does the old saying "knowledge and practice go hand in hand" hold so true. I can write an article about distortion and describe the causes and effects, but the written word cannot tell you how distortion *sounds* so you will recognize this symptom is an improperly operating receiver. Then, too, I can tell you that non-linearity will cause distortion—just so many words, but once you place an improper bias on an amplifier tube causing the negative swings of the signal to be amplified less than the positive swings, you will know what non-

linearity means in an amplifier and won't forget how it sounds.

This is how NRI has solved your problem of gaining practical experience: Get a second-hand A.C. superheterodyne which is in working condition, with at least five tubes. An all-wave receiver is not necessary but try to get a standard brand receiver such as Philco, General Electric, RCA or other well-known makes. If you do not have A.C. power, use a 6-volt receiver or an auto radio since they will give you the same experience as may be gained with an A.C. set.

This receiver is to be used as your experimental set and you are to dissect it just like a student doctor would a dead body. You, however, have the advantage of the medical student in that your receiver is alive and kicking and you can get first hand information on its reaction to different illnesses and accidents. These troubles are to be introduced into the receiver by you and you are to note the effect on the sound of leaky condensers, open filters, burned out (open) resistors, etc.



When you get your receiver, write to us giving its make, model number, and the type numbers marked on the tubes used in it and the fact that the receiver is to be used for training purposes. We will be glad to send you a diagram.

This is the only easy and sure way of getting started. Some men try to do service work with no experience to back them up and while they may succeed, it's a long hard road full of disappointments, so take my advice and follow a logical systematic method which will lead you quickly and surely to your goal of being an expert serviceman.

Although theory and the NRI plan will give you the ability to diagnose and repair defective receivers it will not let you decide which of a given number of parts is most likely to cause trouble. For example, in the A.C. Superheterodyne, an overload on VT₅ would cause its plates to become red hot. This could be caused by a breakdown in the filter condensers, a grounded B+ lead, a short between the screen and cathode of VT₄, or a short between the filament winding of VT₅ and the grounded static shield of the power transformer. What would you look for first? I would look for broken down filter condensers, then a shorted B+ lead, then a shorted tube, and last a defective power transformer. I have never encountered a transformer defective in such a manner and would check it only as a last resort simply because the schematic shows it could cause trouble.

As a beginner you have no means of getting first-hand information of this sort. You must get your

experience second hand. Reference Book, 14X-1, which you receive early in your course, is full of probable causes of different types of defects. Study this book and try to visualize the reasons why the listed causes will result in the described defects. It is an excellent policy to refer to this book when you encounter some unfamiliar receiver symptoms.

Another excellent source of second-hand experience are the service notes, published in many of the popular radio magazines. As a matter of fact the true value of these notes lies in the fact that they tell you: Filter condensers are often defective, coupling condensers can cause intermittent reception and distortion, volume controls eventually get noisy, and so on. The original purpose of service notes was to list weak points in receivers, but sets are built better nowadays and weak points in a complete line seldom develop. Therefore service notes should be viewed as individual defects which might not again be encountered in the specified model. But



read them and use them by remembering that a leaky coupling condenser in an Atwater Kent will cause distortion just as quickly in a Grunow.

All service notes are not authentic. Johnny Jones made famous in verse at the beginning of this story, has a superhet (similar to that shown in Fig. 1) which distorts and, to his everlasting dishonor, finds that shorting R_6 in the voltage divider eliminates the distortion. So a service note is born, and all the other Johnny Joneses make a mental note to correct distortion by shorting resistors.

Now you, one day if not now, reason: Resistor R_6 is the bias resistor for VT_3 . If shorting it out removes distortion, there is too much voltage across it. This is due either to a change in value of the resistor or to excess current through it. The resistor value is correct so those parts which, if bad in a certain way, could cause excess current are checked for such trouble. Resistor R_7 is checked to see if it has decreased in value as is R_8 and we check for leakage in condenser C_{13} .

The moral is to take service notes with a grain of salt, and to forget about them if you can see that they are unreasonable.

New Subjects to be Covered in License Exams

After July 1, 1948, men taking the FCC examination for a 1st class radiotelephone license will be examined on supplemental material not covered in the July 1, 1939 "Study Guide and Reference Material for Commercial Radio Operator Examinations." Many of the questions on the new supplemental material covered will deal with FM and Television.

As rapidly as supplements to this Study Guide can be prepared they will be available without cost at field examination offices of the FCC and from the FCC, Washington 25, D. C. Persons requesting supplements by mail should indicate the examination elements they wish to study.

— n r i —

Several Radio and TV Positions Open

One of the largest department stores in Washington, D. C., is greatly expanding its Radio and Television service facilities. This store is in need of thoroughly trained and experienced technicians.

Several excellent supervisory positions may also be open for men with exceptional technical qualifications and experience in handling men.

NRI men interested in more information should write to L. L. Menne, Director Graduate Service Dept., NRI, 16th and U Sts., N. W., Washington 9, D. C. Your name will be referred to the above concern and they will send you an application form.

— n r i —

TELEVISION BOX SCORE

Stations Operating	22
Construction Permits Granted	71
Applications Pending	229

(AS OF MAY 13)



N.R.I. ALUMNI NEWS

Ernest W. Gosnell	President
Harry R. Stephens	Vice Pres.
Harvey W. Morris	Vice Pres.
H. J. Rathbun	Vice Pres.
James J. Newbeck	Vice Pres.
Louis L. Menne	Executive Secretary

A WORD OR TWO FROM THE PRESIDENT OF THE NATIONAL RADIO INSTITUTE ALUMNI ASSOCIATION

I am very much gratified with the fine reports I receive from Headquarters regarding the progress of the NRI Alumni Association. We are moving forward on all fronts.

It is a very significant fact that our Alumni Association has gained in membership every single year since it was organized in the fall of 1929. At that time we started with seventy-five charter members. At the present time our membership is approximately 7800. During the past twelve months we have made a gain of about one thousand members.

Mind you, this has been a natural growth. We have made no intensive membership drives. When a student completes the NRI Course and is duly graduated he is invited to join the NRI Alumni Association. The great majority of our graduates take advantage of the invitation. Some put the matter off. Perhaps they lay the letter aside. Later many of these join the Alumni. Beyond this simple invitation we have not urged our graduates to join the Alumni and I think, therefore, our record is a remarkable one in loyalty to our organization.

The National Radio Institute Alumni Association is a distinct and unique association. True, it is an organization of Radio servicemen and we are all primarily interested in things pertaining to Radio developments. However, we have a deeper tie than that. We are all graduates of the National Radio Institute and we are eligible for membership in this fine organization because we have qualified for this privilege. Of course only graduates of the National Radio Institute

may become members of our Alumni Association.

I have been a member of the NRIAA since I graduated in 1937. I have always been happy to take an active part in the work of the organization. I have seen it grow and I have grown with it. I am proud—very proud of the office I hold this year. Being elected President of the NRI Alumni Association was one of the great events in my life.

I get very fine reports, through Headquarters, of the proceedings at local Chapters in Chicago, Detroit, New York, Philadelphia, and my own Chapter in Baltimore. I served Baltimore Chapter as Chairman for five consecutive years and during all that time I never missed a single meeting. That speaks well for the good fellowship we find at these get-togethers. I always have and still look forward to each succeeding meeting where I may spend a few hours in interesting discussions with other members regarding the great field of Radio.

I send my greetings to all members of our Association. I repeat, I am immensely flattered because of having been elevated to the Presidency of this organization. The confidence of our members is greatly appreciated by me. I am happy to say that this year, like all previous years, is another big one in the annals of the NRI Alumni Association. My very best wishes to all members.

Fraternally yours,
E. W. GOSNELL,
President, N.R.I.A.A.

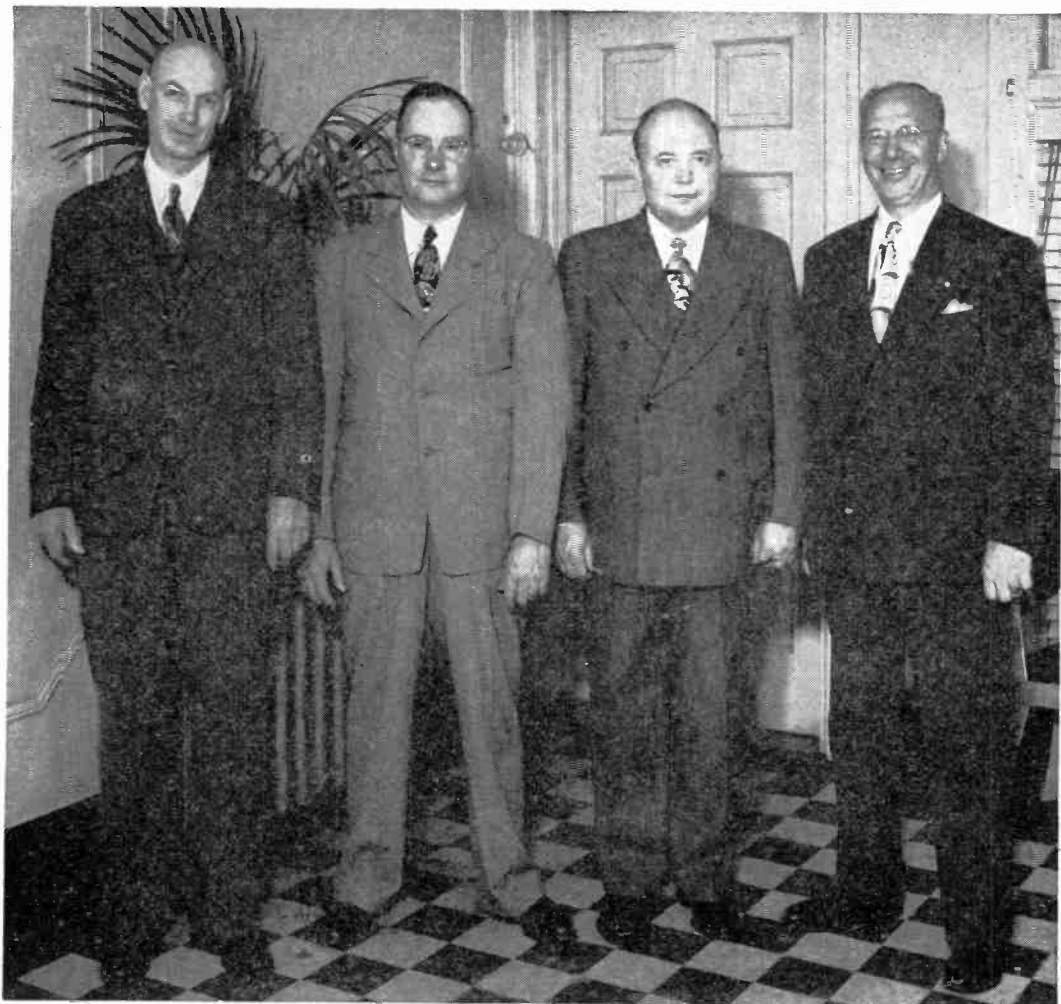

H. J. Rathbun, Vice President; Ernest W. Gosnell, President; Clarence Stokes, President in 1940; and L. L. Menne, Executive Secretary of the NRI Alumni Association, get together at a meeting of Baltimore Chapter, April 27, 1948.

CHAPTER CHATTER

As we go to press we have just returned from a visit to Baltimore Chapter where we attended their semi-annual party . . . held at a very swanky place known as Baker's . . . fine attendance, good food and music . . . see photo in this issue. President Gosnell was very much in evidence as was also Vice President H. J. Rathbun . . . a special guest and a very welcome one was Clarence

Stokes formerly of Philadelphia but now stationed at Middle River, Maryland. He is a past president of the NRI Alumni Association. Made a nice little talk.

Chairman Marsh doing a fine job, ably assisted by Secretary Arthur F. Lutz . . . good meetings last several months. A fine talk by Clifford M.

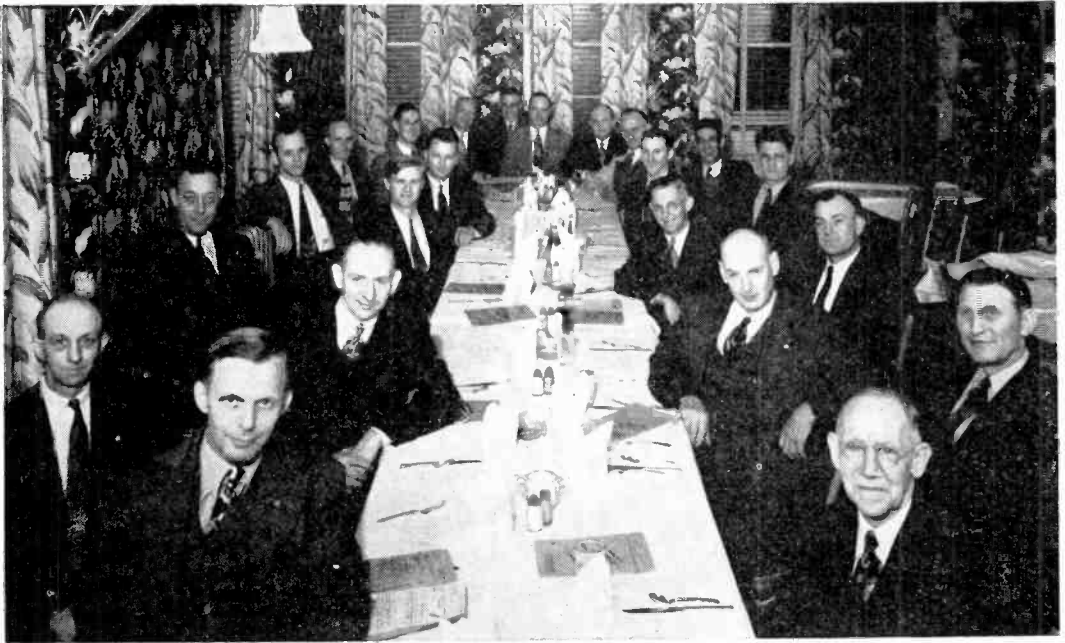

After a short business meeting on the night of April 27th, members of Baltimore Chapter adjourned to one of Baltimore's famous eating places for a dinner and some fun. Here they are just getting started. The modest fellow stooping down way in the back is Chairman Percy E. Marsh.

Whitt on "Inside the Vacuum Tube"! Nicely illustrated on the blackboard.

Interesting discussion afterward. Mr. Butler, another of our members gave a splendid talk on the 'Scope he is building. Went into great detail and it was all interesting and educational. . . . Teaser questions are put forth by Mr. Whitt, Mr. Butler, Mr. Clark, Mr. Rathbun, Mr. Gosnell and other members. The question is asked at a meeting and the answers are turned in at a following meeting. This leads to a very interesting forum discussion and is working very nicely.

New members are Philip Scholtes and Elmer Maben. Mr. Maben was a member some time ago but had to drop out. We are very happy to have him back with us. Franklin Almony, a student, paid us a visit. Always glad to have visitors. . . . Rathbun is very cheery about his NRI Professional Radio Tube Tester. Likes it very much. Rathbun, by the way, is specializing in Television. He is taking some postgraduate work. A real live wire, that fellow. . . . At another meeting Mr. Kelly and Mr. Strupp were the speakers. John R. Klatter joined our chapter on that occasion.

During the illness of our chairman, Alumni

President Gosnell took over. At the same time, in the absence of the Secretary, our charter member John B. Gough stepped into the breach. . . . With everything going nicely in Baltimore let's turn to Philadelphia.

In the city of Brotherly Love the Chairman is Harvey Morris who is also our National Vice President. He tells us that John Biaselli, a member of Philadelphia Chapter of long standing and now a Staff Sergeant in the Marines, is a frequent visitor at Philadelphia Chapter. Being stationed near Philadelphia he attends meetings quite regularly. He is an expert radioman and does an excellent job of lecturing especially when accompanied by a blackboard description. . . . Financial Secretary Ray Hamilton had a change in his hours requiring him to work nights. . . . Milton DeVac volunteered to take over the job and was unanimously elected. If you do not have automobile insurance better see Milton. He has an interesting proposition which he will be glad to present to any one who will listen. . . . Chairman Morris, wanting to know more about Television, has taken a job with a Philco distributor as a Television serviceman. Works as a troubleshooter in the shop. Was surprised when his shop supervisor, Mr. John Iula showed him his NRI Alumni card.



Thanks to member Fred Korn we finally got a picture of Chicago Chapter. Here it is with the group crowded around some of their equipment. Fine bunch of fellows.

Now to the big city of New York where things continue to move along beautifully. A great crowd there. . . . Fifty to sixty at a meeting is just an average attendance. Often goes much higher. Here are some of the speakers and subjects. Antosh on Servicing Tips, Richard Patten on Signal Paths, Ralph Georg on A.B.C., Alex Remer on Power Packs, Antoine Corse on Polarities. Mr. Corse is a graduate of NRI, but because he is unable to attend meetings regularly is not a member of our chapter. However, he is going to join very soon, we hope.

Other speakers and subjects, Robert Weiner on Common Sense in Radio Servicing. Peter Guzy on Polarity, Alexander Brack on Distortion in the Output Stage, Eugene Williams on Television. . . . Frank Zimmer conducted a new type of quiz program. Joel Robinson spoke on Television. William Fox gave one of his interesting talks on his Radio experiences. . . . In fact most of these speakers have talked on several occasions since our last report. They are all very popular with our members and are greatly responsible for the very fine attendance we continue to have.

Page Thirty

Chairman Wappler and Secretary Kunert doing their usual fine job. Executive Committee meeting regularly to plan programs. Everything is done by program in New York. Things are thought out far in advance. That is why there is never a dull meeting. Never a time when there is a lapse. Always someone prepared and ready to do his job. . . . If you live in the New York area and are not a member of the Chapter, whether student or graduate, drop in on the fellows some meeting night. You will receive a cordial welcome.

All the way back to Chicago where we have been getting some fine reports from Secretary Brodhage and from a very active member, Fred Korn. Finally got a photograph but the secretary explains that only part of those who are active in the Chapter are shown in the photograph. No announcement was made that the photograph would be taken. An interesting looking group nevertheless. Some interesting discussions on F.M. . . . former Chairman Bognar met with a serious accident. Almost lost two fingers but coming along nicely. Should stick to radio and leave table saws alone.



Detroit Chapter in session. Earl Oliver in front foreground (right). The nonchalant gentleman in the white shirt is Floyd Buehler. Notice the lapel buttons to identify members by name. A fine way to know one another more quickly.

Chairman Oliver of Detroit Chapter gets some special attention from John Nagy and Ralph Favor of KLA Laboratories. Mr. Nagy is a member of Detroit Chapter. He and Mr. Favor spoke to the members on Recorders.

Mr. Hill of Supreme Instruments Corporation was one of our speakers. We are very grateful to Mr. Hill for his fine talk. Our own Albert Horvath spoke on the a.c.-d.c. power supply units. . . . Chairman Immel busy as a bee and doing very nicely. New officers elected to fill vacancies are H a r r y Andresen, Librarian and Steve Bognar, Sergeant at Arms. Louis Brodhage was re-elected Secretary. Still meeting at 2759 South Pulaski Road, which is entirely satisfactory except we are somewhat crowded when we have a good attendance.

members liked it very much. Floyd also spoke on F.M. antennas. . . . Would make a swell National Officer . . . that man Buehler.

A service forum was conducted by Chairman Earl Oliver. Two radios were brought in for repair. Earl did the work explaining each step as he proceeded.



Our usual method of servicing a set before the members was for them to crowd around and watch the actual servicing. This time we departed from the usual procedure. The test instruments were elevated above the table so everyone could see them easily. Also, instead of crowding the table everyone was told to remain seated but to draw their chairs up as close as possible. This proved very much superior to our old way and everyone derived genuine benefit. . . .

Over Lake Michigan now to Detroit. Swell reports from Chairman Oliver and Secretary Stephens. Messrs. Harrje, Kettimon and Laszlo of Philco gave a very fine demonstration and talk on the record player with beamolite pickup. Mr. Laszlo proceeded to assemble a changer and the other gentlemen explained the operations and gave interesting highlights on the various units. They also gave an interesting demonstration of the popular '46 slot type record changers and many good service pointers were given.

Another meeting of Detroit Chapter. Guest speakers were Messrs. Harrje, Kettimon, and Laszlo of Philco. Here two of the gentlemen are demonstrating a record player with beamolite pickup.

Thanks to Floyd Buehler for furnishing the cokes at one meeting. A new Television Studio and Transmitter is being installed in the building where we hold our meetings. Very impressive. And now the big news is left for last mention. Our annual meeting and party will be held on June 16. The committee is hard at work. . . . At this writing it looks as though we will go to Windsor where the committee has just the right spot in mind. That's all for now!

Floyd Buehler frequently is one of our speakers. Oddly enough a favorite talk is on the slide rule. Did not sound like a very popular subject but the

NATIONAL RADIO NEWS

FROM N.R.I. TRAINING HEADQUARTERS

Vol. 13 June-July, 1948 No. 3

Published every other month in the interest of the students and Alumni Association of the

NATIONAL RADIO INSTITUTE
Washington 9, D. C.

The Official Organ of the N. R. I. Alumni Association.
Editorial and Business Office, 16th & You Sts., N. W.,
Washington 9, D. C.

L. L. MENNE, EDITOR
J. B. STRAUGHN, TECHNICAL EDITOR

NATIONAL RADIO NEWS accepts no paid advertising. Articles referring to products of manufacturers, wholesalers, etc., are included for readers' information only, and we assume no responsibility for these companies or their products.

Index

Article	Page
Editorial	2
Antennas for FM and Television	3
Servicing Wire Recorders	15
Everybody Gets the Blues	18
Our Cover Photo	19
Developing the Ability to Diagnose Receiver Troubles	20
NRI Alumni Association News	27
Chapter Chatter	28

Printed in U.S.A.

POSTMASTER: If addressee has removed, notify sender on FORM 3547 postage for which is guaranteed.

NATIONAL RADIO NEWS
16th & U Sts., N.W., Washington 9, D. C.

Published every other month by
National Radio Institute
RETURN POSTAGE GUARANTEED

For:

Mr. Harold R. Rueth
RFD 3
Jefferson, Wis.

226 YE 42

2A

U. S. POSTAGE
1c PAID
Washington, D. C.
Permit No. 7052