

# NATIONAL RADIO NEWS

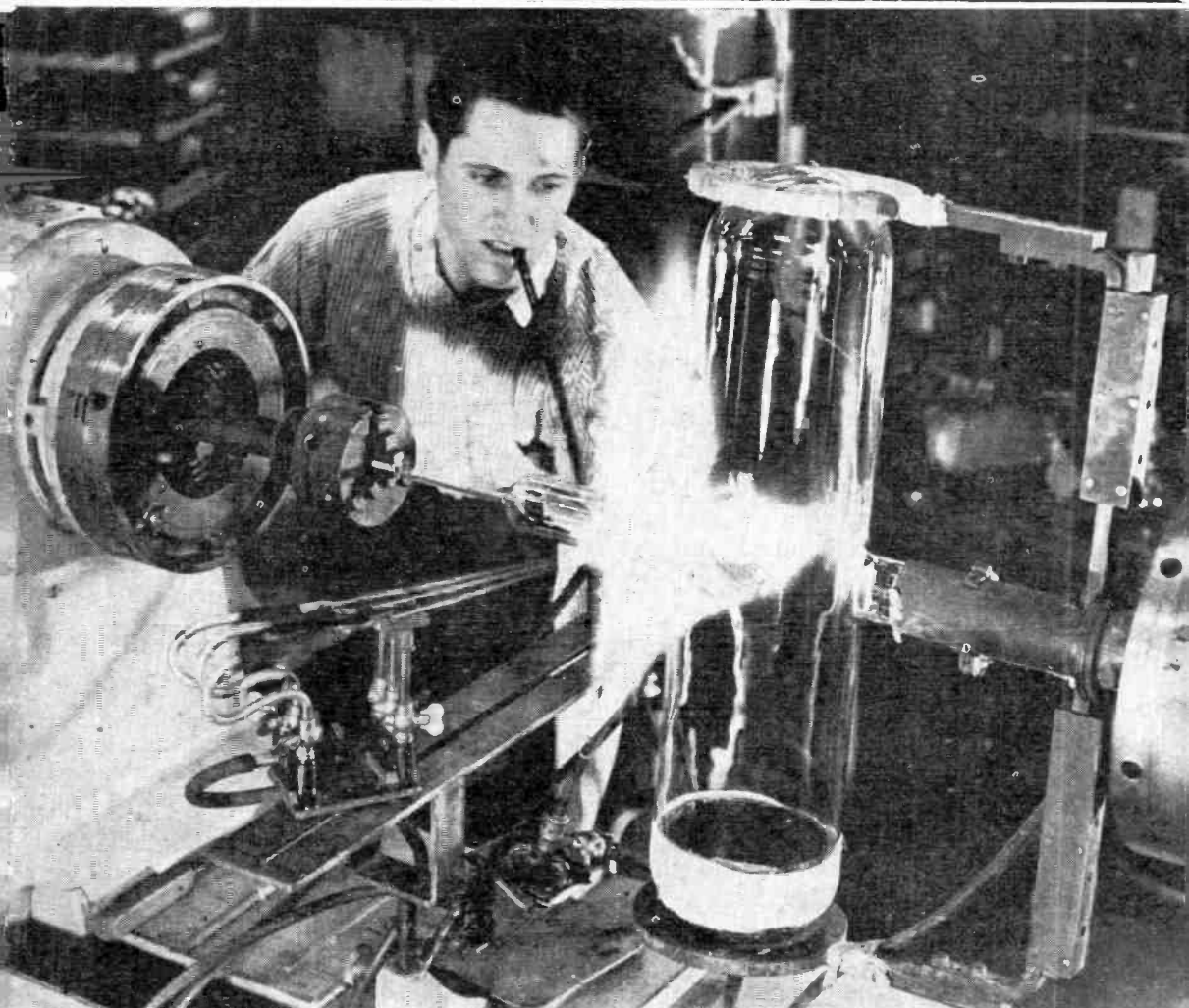

## IN THIS ISSUE

Crystal Pickups

How to Test Resistors and Condensers

Alumni Association News

Apr.-May  
1947

VOL. 12  
No. 8



---

---

## JOT IT DOWN

Every man is ambitious. Every man wants to develop his mind. The great trouble with most of us is that we study hard but we do not do it systematically. We do not pause often enough or long enough in our reading to affix impressions upon our minds. We rely too much upon memory instead of stopping occasionally to make notes.

Robert Louis Stevenson carried two books with him always—one to read and the other to write in.

Keep a note-book. Jot down in it each idea, each thought you want to retain. The mere act of making a note tends to fix the thought permanently on our minds. Writing clarifies thinking and aids in concentrating on a subject.

Learning is essentially a process of transferring to the mind that which you read. But no mind can fully absorb everything in a text-book even when read several times in the ordinary manner. To read a text-book is one thing; to study a text-book is something entirely different. Each passage has one or more important facts; locate these, and jot them down in condensed form in your note-book. The act of condensing an idea into a few of your own words, then writing these words will invariably fix the idea in your own mind, there to stay for all time.

Memory is fickle—never rely entirely upon it for the preservation of important ideas. Try writing out things you want to remember; try this for a while, and see how much easier it becomes to master what you read.

E. R. HAAS, Executive Vice-President.

# Crystal Pick ups

by

J. K. Poff

Astatic Corp.

## A Discussion of Crystal Reproducing Cartridges, Their Theory and Application

*"Copyright, 1946, The Astatic Corporation; Reprinted by Permission"*

SINCE the early 1930's, electric phonographs and radio phonograph combinations for home use have appeared on the market in ever increasing quantities; and performance has been steadily improved through the years, to the degree that reproduction of recorded sound today is indeed pleasant.

The success of these devices is due largely to the development and improvement of pickup cartridges, using crystal elements of Rochelle Salt (Sodium Potassium Tartrate). Use of this substance has resulted in improvements such as decreased needle pressure, higher output voltage and wider frequency response. It is no longer necessary to employ an expensive pre-amplifier and complicated equalizer in conjunction with a phonograph pickup in order to obtain satisfactory reproduction of records. The voltage developed by cartridges of this type is sufficient to enable them to perform satisfactorily with ordinary low-gain types of amplifiers.

The comparatively low cost of crystal phonograph cartridges, together with their other advantages, has allowed radio and phonograph manufacturers to produce equipment for home use, priced well within the means of almost everyone. Cartridges are made with a wide variety of characteristics to suit various applications, see Fig. 1.

Maintaining this equipment has become a very profitable endeavor for many radio servicemen. There are many others, however, who have shied

away from this phase of service work for various reasons, not the least of which is a feeling that they do not understand it. This is unfortunate since there is really nothing too complicated about it.

It is felt that a few facts concerning the operation, application and care of crystal cartridges presented here might be helpful.

### Principle of Operation

In 1880, the famous Madame Curie, working with her husband, discovered that certain crystals would develop electrical charges on their surfaces when subjected to mechanical stresses. These electrical charges became known as piezoelectricity (electricity developed due to pressure or torsion). This is the principle upon which a crystal pickup cartridge functions.

The needle following the groove of a record upon which sound has been recorded, is vibrated in proportion to the amplitude of the recorded sound (Fig. 2). This vibration is imparted to the crystal element through a needle chuck or torque wire assembly. The illustrations in Fig. 3 show side by side, the construction of a low needle pressure type cartridge and of a conventional removable needle type cartridge.

In both, a torsional crystal element (twister) is used and is so mounted that the needle vibration imparts torsional forces to the crystal element. The motion of the vibration system is

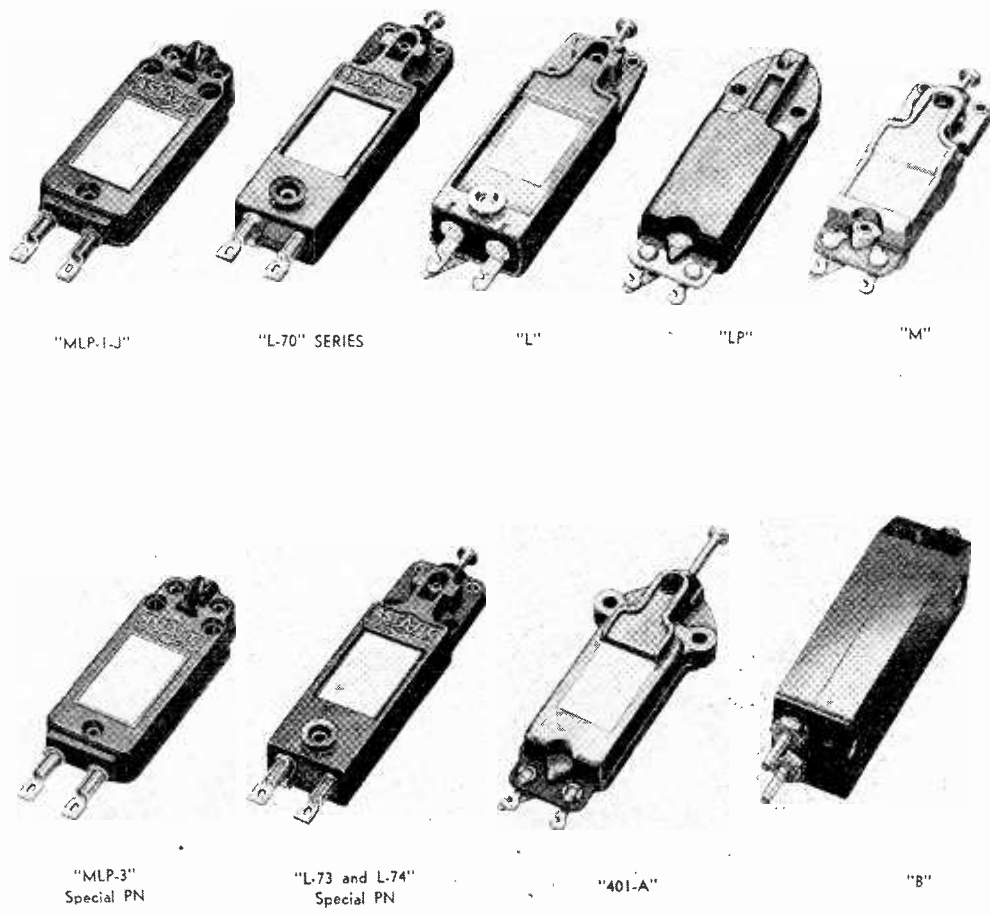

Fig. 1. The complete Astatic line of crystal cartridges designed to meet the needs of a wide variety of applications.

almost entirely absorbed by the twisting of the torque wire in the low pressure cartridges, and by the flexing of the coupling rubber in the conventional type, so that the crystal, practically speaking, does not vibrate. However, the flexing of the torque wire, or coupling rubber, applies forces to the crystal directly proportional to the needle motion and the crystal generates voltages corresponding to these forces. Various types of rubber and other damping materials such as viscoloid, etc., are used for controlling output voltage, frequency response, and other performance characteristics.

**Application**

Crystal cartridges are made in a great number

of styles with a wide variety of electrical characteristics in order to accommodate a multitude of various applications.

The size, shape, and required needle pressure of the cartridge have a great deal to do with the styling of the pickup arm. The output voltage and frequency range of the cartridge are factors taken into consideration by equipment manufacturers when they are designing the amplifier and speaker combination with which the cartridge is to be used. Much time is spent on the circuit design of an amplifier, and a crystal cartridge used for reproduction of records becomes one of the basic components of the amplifier input circuit.

We all know that components of any circuit can-

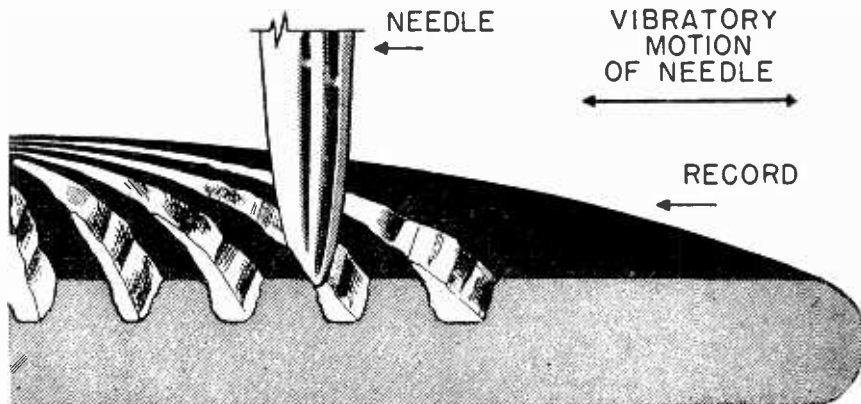

Fig. 2. A greatly enlarged view of a record and needle, showing the needle following the record grooves. The needle is vibrated in proportion to the amplitude of the recorded sound.

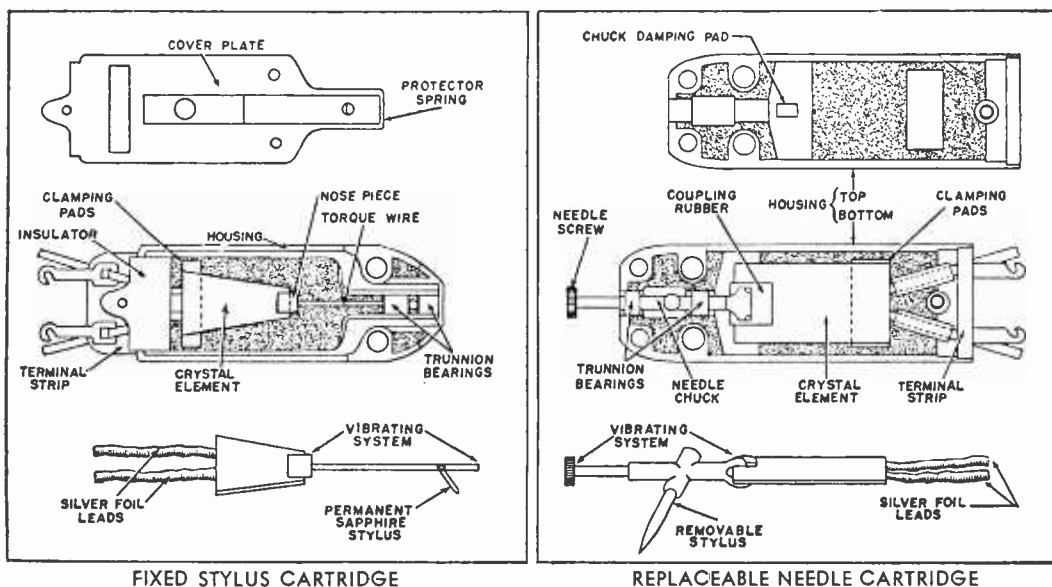

Fig. 3. The cartridge at the left is the low pressure type with permanent needle. The cartridge at the right is the conventional type with a replaceable needle.

not be replaced with any but those of like characteristics without disturbing the circuit balance and changing its performance. When it becomes necessary to replace a crystal phonograph cartridge, this should be done with an exact substitute or duplicate of the original for best results.

Crystal replacement cartridges are manufactured with characteristics exactly like those of the original equipment cartridges. Cases have come to our attention where original units were re-

placed with others having different electrical characteristics with the object in mind of improving performance. The results in some of these cases were very unsatisfactory. Many times people have written in condemning certain types of cartridges and have gone to great lengths explaining why they do not like a particular model. When the truth was learned in many of these cases, it was found that the original cartridge had been replaced and that the one then being used was, in most cases, entirely inadequate

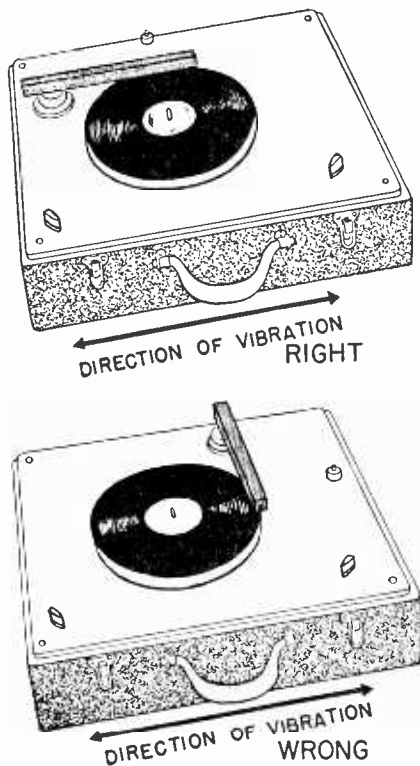

Fig. 4. Method of mounting pickup to minimize the effects of vibration. The pickup arm should be parallel to the direction of vibration.

for use with their equipment.

Take for example the fellow who, possessing a fairly good, late model, pre-war receiver with a record-changer attachment, decided he wanted to improve the performance of his equipment by replacing the original cartridge with a more recently developed model. The output voltage of his original cartridge was approximately 2.5 volts at 100 cps. The cutoff frequency of this cartridge was approximately 4000 cps and the needle pressure was  $2\frac{3}{4}$  ounces. The cartridge which was selected to replace the original had an output voltage of 1.0 volt, a needle pressure of one ounce, and a greatly extended frequency range, cutting off at 10,000 cps. When the cartridge was installed, the pickup arm was counterbalanced for one-ounce needle pressure. This caused considerable trouble with the record changer trip mechanism since it was designed to operate at the greater needle pressure required by the original cartridge. A decided loss in output was noticed (which was due to the decreased output voltage)

and because the audio-amplifier of the receiver had insufficient gain, the volume could not be adjusted satisfactorily.

In addition, the amplifier was not capable of handling the same frequency range as the new cartridge and, therefore, the results of this installation proved very unsatisfactory. Satisfactory reproduction was again obtained when a replacement cartridge exactly like the original was again installed.

There have been cases where servicemen, thinking to better the performance of a client's phonograph, have substituted a higher output, wider range cartridge for a low output, medium range cartridge. These installations likewise proved unsatisfactory, introducing such disagreeable factors as distortion, acoustical feed-back and tracking difficulties. Satisfactory performance was again restored when an exact replacement cartridge was installed.

As has been previously stated, much time is spent designing the amplifier and speaker combination and much thought given to the choice of a suitable cartridge for use with the completed equipment. It is strongly advocated, therefore, that, when it becomes necessary, crystal cartridges be replaced with exact replacements or substitutes recommended by either the equipment manufacturer or the cartridge manufacturer.

Many people prefer to have their record reproducing systems assembled with components of their own choosing, with the idea in mind of obtaining something not quite so commercial and more suitable to their individual taste. Servicemen are often called upon to express their opinions and make recommendations regarding these components. Before recommending a pickup or cartridge for use with such a system, it should first be determined just what kind of record reproduction is desired. This is very important, since everyone has individual taste, insofar as this is concerned. Some people prefer classical music (the so-called "long-haired" type), others like "boogie-woogie." Some want a booming bass while others desire a high-pitched response. The pickup or cartridge should then be selected, taking these preferences into account, and not because the serviceman happens to prefer one type or model above another.

The technical specifications of pickups and cartridges should be consulted prior to making selections or recommendations. Information concerning output voltage, needle pressure and frequency range is of particular interest and value. Selection of the proper pickup, and accurate installation thereof, will determine to a great extent the type of reproduction which may be obtained.

Care should be exercised when installing a pickup arm to make sure that the motorboard is per-

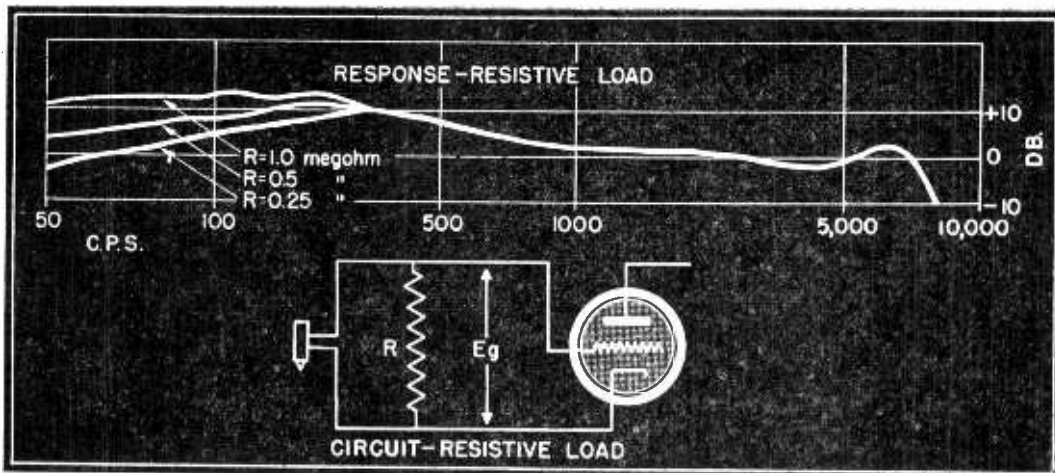

Fig. 5. Method used to connect a crystal pickup to an input stage. The curve above shows the effects upon the response of changes in the value of 'R'. Decreasing the resistance decreases the low frequency response.

fectly level and that the pickup is mounted squarely; otherwise, the needle will not properly "ride" the record grooves, causing excessive needle and record wear.

If the amplifier, with which the pickup is to be used, is of the high gain, high output type and it is necessary that the volume be kept at a high level, it may be advisable to install the pickup and turntable mechanism in a compartment or cabinet, separate from the speaker, in order to prevent feedback.

Certain types of turntable motors may cause a considerable amount of vibration with regard to the turntable, which may produce a disagreeable rumbling noise.

Before installing a pickup on the motorboard of a turntable using such a motor, the direction of maximum vibration should first be determined. The pickup arm should then be installed so that it is parallel with the vibrating motion (See Fig. 4). Observance of this precaution will do much toward preventing this rumbling.

#### Equalizers, Circuits, and Their Use

It is sometimes advisable and often necessary, due to the many individual tastes involved, that an equalizer be employed in the input circuit of an amplifier, in series with the phonograph pickup, in order that the response of the pickup be entirely satisfactory to the listener. This is especially true with radio receivers or amplifiers which were not originally designed for phonograph operation.

An understanding of the proper application of

equalizers would be of great help to the serviceman called in for consultation and advice by the listener whose equipment does not have enough low frequency or sufficient high frequency response to suit him. As we stated before, everyone has individual taste insofar as tonal response is concerned. The serviceman's understanding of the application of equalizers, his ability to effect changes, make necessary recommendations, or otherwise help the user to obtain the desired results, will prove invaluable.

Circuits shown here are standard circuits and are used and recommended by many engineers. It is possible by properly applying these circuits to vary the frequency response of a crystal pickup in order to meet many requirements.

Crystal pickup cartridges are high impedance devices and should therefore be connected across a high resistance load, the usual value employed being 0.5 megohms. By decreasing this value, the low frequency response of a pickup cartridge may be decreased, while increasing the value will increase the low frequency response of the cartridge (See Fig. 5). However, if this value is made either too high or too low, the bass and treble balance of the cartridge may be upset and the overall performance unsatisfactory. For best results with average crystal cartridges, this value must be kept between 0.25 megohm and 1.0 megohm.

With the value of load resistance being adjusted for optimum low frequency response (optimum, in this case, being that which is most satisfying to the individual listener), the pickup may be

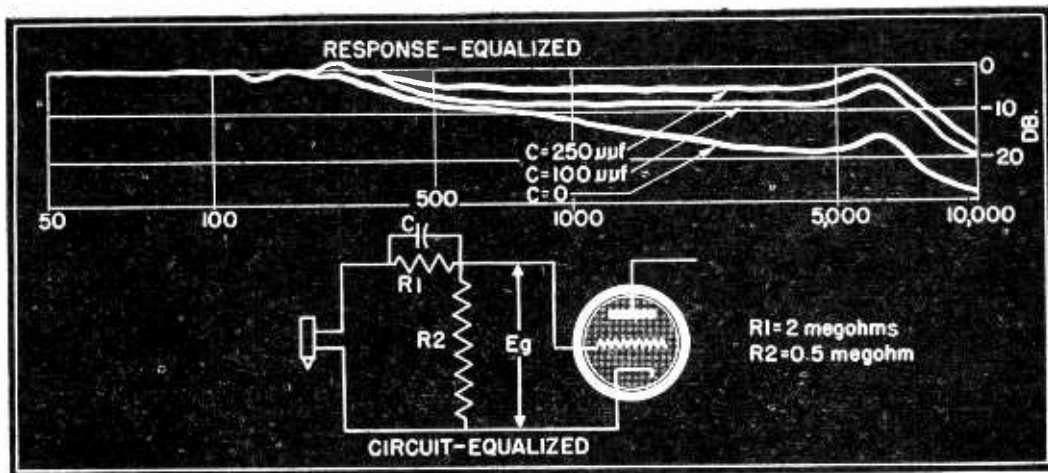

Fig. 6. In this circuit an equalizer has been added. The capacitance  $C$  affects the high frequencies while the resistances  $R-1$  and  $R-2$  primarily affect the base response. The curve shows the effect of various values at  $C$ .

further compensated by using the equalizer circuit shown in Fig. 6. The value of capacitance to be used is usually between 50 uuf. and 500 uuf., depending on the amount of high frequency response desired.  $R-1$  may be between 1.0 megohm and 5.0 megohms. When the sum total value of  $R-1$  and  $R-2$  is 2.0 megohms, maximum bass response is obtained. Any further increase in value of  $R-1$  has no further effect on the low frequency response of most cartridges. Further increase in the value of  $R-1$  does, however, minimize the effects of increased temperatures on the low frequency response. As the temperature increases, the low frequency response of the cartridge has a tendency to decrease slightly; and if a condition exists where the operating temperature varies between normal room temperature (approximately 70° F.) and 100° F., to 110° F., it may be advisable to employ a higher value of resistance for  $R-1$ .

It should be noted that as the value of  $R-1$  is increased, the value of capacitance should be decreased proportionately. Another important fact to remember is that when a circuit is equalized, there is necessarily a reduction in output of the cartridge, and, therefore, it may be that increasing the value of  $R-1$  will not allow sufficient excitation voltage to reach the input tube grid to enable the amplifier to deliver its full rated power output. If this is the case, it is best that the sum total values of  $R-1$  and  $R-2$  be held to 2 megohms or less.

By using a slightly more elaborate circuit, such as shown in Fig. 7, both high and low frequency response may be varied independently. Switch No. 1 is used to control low frequency response,

and switch No. 2 is used to control the high frequency response.

#### Temperature and Humidity Effects

Crystal devices using Rochelle Salt crystal elements function best at temperatures between 70° and 80° F. when the relative humidity is approximately 50 percent. They are very much like human beings in that wherever humans can live comfortably, the crystal element will function normally and have a very long life span.

The piezoelectric limitations of Rochelle Salt crystal pickup cartridges are between -40° F. and +120° F. If exposed to temperatures above 120° F., the crystal will lose its piezoelectric activity permanently.

Plenty of ventilation should be provided around the phonograph or radio cabinet in order that the temperature around the pickup be kept at the lowest possible value. Pickup cartridges and other crystal devices should not be stored near heaters or radiators, nor should they be displayed in store windows or show cases where bright sunlight is apt to shine. When leads are being soldered to the cartridge terminals during installation or service, the soldering iron should *not* be applied for a longer period of time than necessary to make a solid joint. Terminals are well tinned during manufacture; and if the leads are also well tinned before connection is made it is only necessary that the soldering iron be applied to the joint long enough to "flow" the solder. It is important that these facts be kept in mind since the nearer to normal temperatures (70°-80° F.) the crystal can be stored or oper-



ated the longer will be its useful life.

In extremely dry climates, crystal pickups have a tendency to become dehydrated (loss of natural moisture) when subjected to high temperatures. Once a crystal becomes dehydrated, nothing can be done to restore it to normalcy.

In climates where the temperature and relative humidity are extremely high, crystal cartridges have a tendency to take on excess moisture. A simple desiccator, such as is shown in Fig. 8, may be used as an aid in controlling this hydration. If the crystal cartridge, when not in use, is stored in the desiccator, the excess moisture will be removed from the crystal element, thus helping to prolong the useful life of the cartridge.

### Testing Pickup Cartridges

Accurate testing of all the types of pickup cartridges requires a specialized type of equipment and a special kind of skill or knowledge on the part of the operator. Interpretation of the results of the test to determine whether the unit is satisfactory calls for a knowledge of average characteristics and tolerances for that particular type of unit. Facilities such as these are not often found outside the cartridge manufacturer's plant; and it is usually impossible to conduct a thorough test anywhere except at the factory. A simple listening test may, however, be conducted by the radio serviceman or technician which will serve to determine whether the unit is operative or defective beyond question.

There is usually available a turntable and an amplifier with speaker to which the unit may

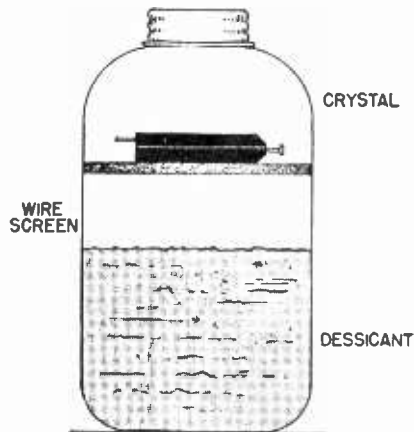

Fig. 8. A crystal cartridge may be stored in this way in humid climates to prolong its life. The desiccator consists of a jar with a piece of ordinary wire screen fitted into it to hold the cartridge above the desiccant liquid. The top should close tightly.

be connected. Cartridges may be coupled to the amplifier through short leads having clips to connect to the cartridge terminals. The cartridge may then be held in the fingers to play the record. A special motorboard with mounting holes drilled to accommodate each of the various types of pickup arms will simplify this test. If there is any doubt at all about the condition of the cartridge, it is best that it be returned to the factory for complete inspection and test.

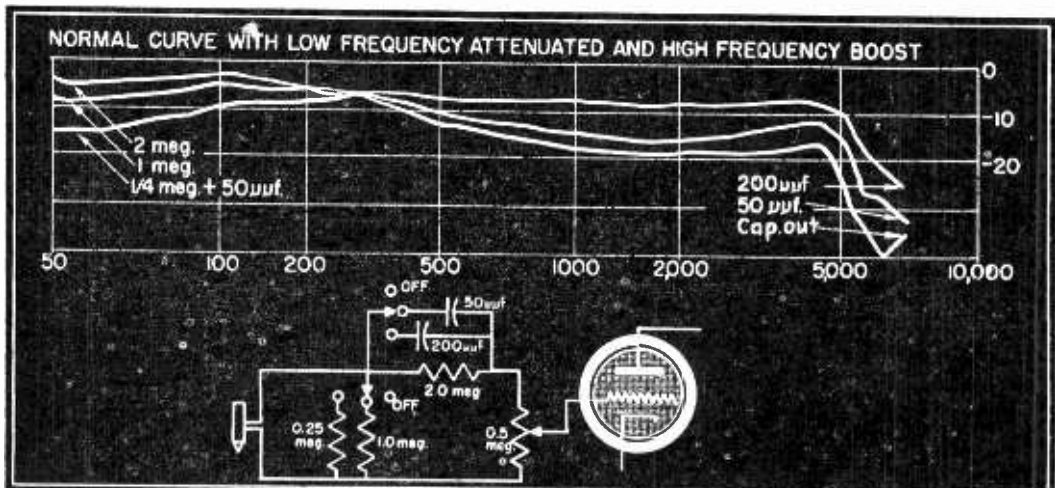

Fig. 7. This circuit permits independent variation of the high and low frequency response. The curve shows the response with various combinations of resistance and capacitance.

All Illustrations by Courtesy of Radio Maintenance Magazine

# A Miniature Selenium Rectifier For Home Receivers

**M**ARKEDLY improving the performance of home receivers and completely trouble-free, the new miniature selenium rectifier stack, developed by Federal Telephone and Radio Corporation, Newark, N. J., means more "customer satisfaction" plus increased profits to the up-to-the-minute serviceman. One of the first advancements made in home radios since the end of the war, this stack can replace all conventional rectifier tubes, is simple to install, and is guaranteed to outlive the receiver, thereby ensuring a minimum of power supply failures.

With many rectifier tubes still hard to get, this latest Federal development should provide a "shot in the arm" for the alert radio repairmen for it has such excellent selling points as instantaneous starting for both AC and DC, less heat (hence longer battery life in portables), trouble-free power supply operation, pilot light failures reduced to a minimum, and more audio output (in 35Z5 circuits).

Selenium rectifiers have been used in electronic circuits for many years but, due to their relatively high cost and large space factor, were not used in home receiver rectifier circuits. How-

ever, by virtue of a new process developed by Federal, this cost and space factor has been reduced to the point where use of the miniature selenium rectifier is entirely practical.

The rectifier stack has two distinct poles, positive



Fig. 2

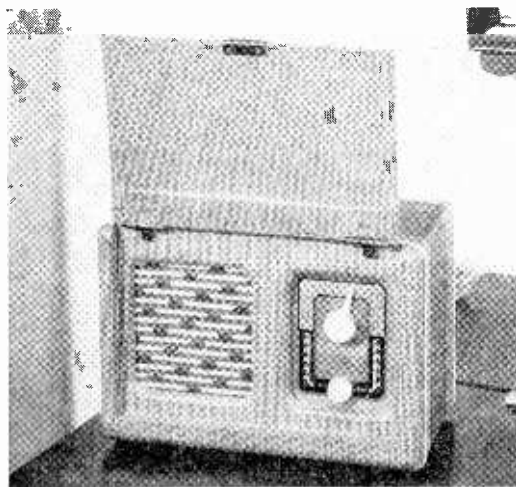

Fig. 1

and negative, corresponding to the plate and cathode of the vacuum tube and can be inserted into the circuit as such. The positive side, denoted by a + sign, is equivalent to the cathode while the negative side functions as the plate. Soldering the stack into the set in this manner constitutes the entire replacement operation unless the filament of the tube was linked to other parts of the circuit, in which case a resistor is used to replace the rectifier tube filament.

Installation of Federal's miniature #403D2625 selenium rectifier can be made right in the customer's home. The set shown in Fig. 1 is a typical three-way portable using a 117Z6 rectifier. As is evident from the original schematic of the power supply (Fig. 5A), the filament of this tube is not interlocked with any other component in the set. Therefore it is only necessary to insert the stack into the circuit as outlined in the previous paragraph. Solder the positive side on pin 4 (cathode), the negative side on pin 5 (plate), and the installation is over.

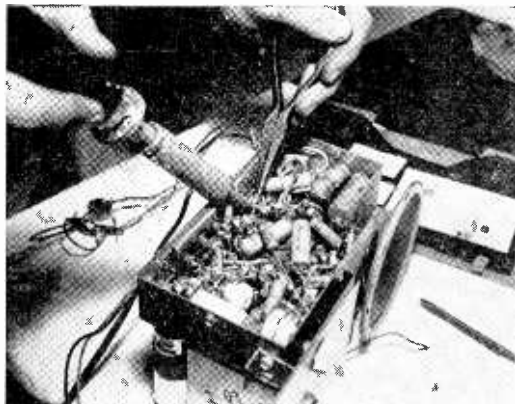

Fig. 3

Only four tools are required to perform the entire 7-minute operation—a soldering iron, screw driver, socket wrench, and a pair of long nose pliers. First the chassis is withdrawn from the cabinet and the tube is removed from the socket. Extension leads are then soldered on the rectifier stack. It is recommended that the positive lead be covered with red wire so as to distinguish it from the negative lead, which is usually made yellow or black (Fig. 2).

It should be pointed out that whenever possible the stack should be installed underneath the chassis. However, in this case, as is the case with many portables, although the stack is only  $1\frac{1}{4}'' \times 1\frac{1}{4}'' \times 11/16''$ , it did not fit underneath the chassis. It was inserted from above in the space that was formerly occupied by the tube. Therefore some type of protective covering should be provided.

Fig. 3 shows the leads which were drawn through the center of the tube socket being soldered to

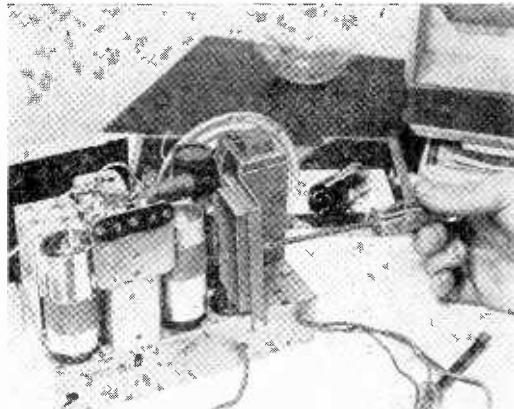

Fig. 4

the appropriate pins, the red lead on pin 4 and the yellow one on pin 5, when a type 117Z6 rectifier is used. The set is then turned on and if the rectifier has been installed correctly, it should start operating immediately.

After installation of the rectifier, check the tube filament voltages. If they are too high for normal tube operation, insert a 27 ohm resistor in the line just before the rectifier to bring the operating voltage of the filament string back to normal.

Finally a protective covering, which is supplied with the rectifier, is placed around the stack and tightened to the chassis with a screw and nut (Fig. 4). The chassis is then put back in cabinet and the job is done.

Three operational improvements have been achieved with the installation of this rectifier. In the first place since rectification now occurs immediately, the set operates as soon as it is

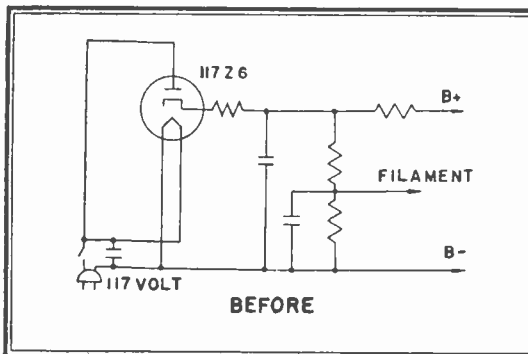

Fig. 5A

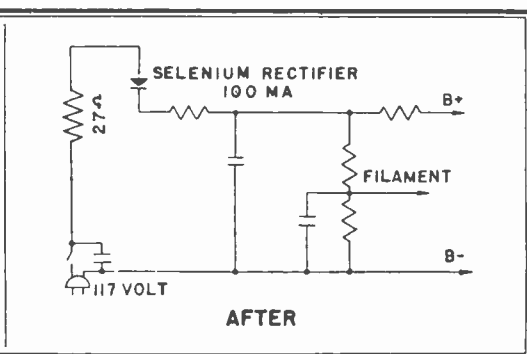

Fig. 5B

turned on in contrast to the rectifier filament warm-up period wait previously required. Secondly, in view of the low internal impedance and high efficiency of the stack, the ambient temperature of the set is reduced by approximately 35° F, meaning increased battery life in portables. Finally the long life of the selenium rectifier means that power supply troubles have been reduced to a minimum.

Federal has developed replacement sheets covering every possible power supply used in home receivers, which give specific, easy-to-follow instructions, on what steps are necessary to install this rectifier. These sheets are available to all servicemen and can be obtained by writing to:

Federal Telephone and Radio Corp.  
200 Mt. Pleasant Ave., Newark, N. J.

If you write the above company about such work, be sure to identify your receiver. State make and model number, and the number and types of tubes used in the set.

Many Radio Jobbers now have suitable Selenium rectifiers in stock.

— n r i —

## Our Cover Photo

ANCIENT ART IN MODERN TUBE MANUFACTURE . . . The ancient art of glass blowing is practiced as G-E employee Warren McDonald blows glass to attach the arm to a large transmitting tube made by the Tube Division of the General Electric Company's Electronics Department at Schenectady, N. Y. The glass worker is attaching the grid-connection arm to the glass envelope of a 100-kw water-cooled transmitting tube.

This blowing operation forms the glass seal and keeps up the air pressure in the tube. Here the camera "captures" the oxygen and hydrogen flames as they seal the union.

— n r i —

"There is a widespread, continuing need for the multiple services afforded by the American Red Cross to our people, soldier and civilian alike. The tasks of the American Red Cross did not end with the war's conclusion. In some fields they have increased in number and complexity. The indispensable services which this organization has extended to our troops at home and abroad, and to patients in service and veterans' hospitals, have received the unstinted praise and appreciation of Americans in all walks of life. I earnestly hope that the public will respond generously during the 1947 Red Cross campaign."

DWIGHT D. EISENHOWER.

Page Twelve



## Electronic Baby Tender

In this era of expensive baby sitters who can't always be found even when needed, the magic of electronics is solving the problem in one apartment house in Syracuse, N. Y.

Robert J. Leichter, an engineer in the General Electric electronics plant, rigged up what he calls an "electronic baby tender." This allows him and his wife Madelyn to leave their first-floor apartment and play bridge evenings with friends on the third floor or elsewhere in the building—yet still hear practically every movement of little 19-months-old Joan Marie in her crib downstairs.

Leichter's problem was solved by using a remote speaker at one end of a 100-foot electric cord and connecting the other to an amplifier and speaker.

When the Leichters visit Robert J. Brown and his wife on the third floor for an evening's bridge, they place the remote speaker (Speaker shown in insert, lower left) next to the baby's crib and string the wire up through the hallway to Brown's apartment.

The amplifier-speaker is plugged in a nearby power outlet, then is placed next to the card table so the bridge foursome can hear any cries or unnecessary disturbances in the baby's crib. Leichter's device is sensitive enough to pick up the baby's breathing.

The novel device may also be used as a two-way communications system. If the baby cries out during the evening, Leichter or his wife calms her by talking into the speaker near the card table. They admit the system occasionally fails to put little Joan Marie back to sleep or keep her quiet—in which case they can always trot down and "take over" personally.

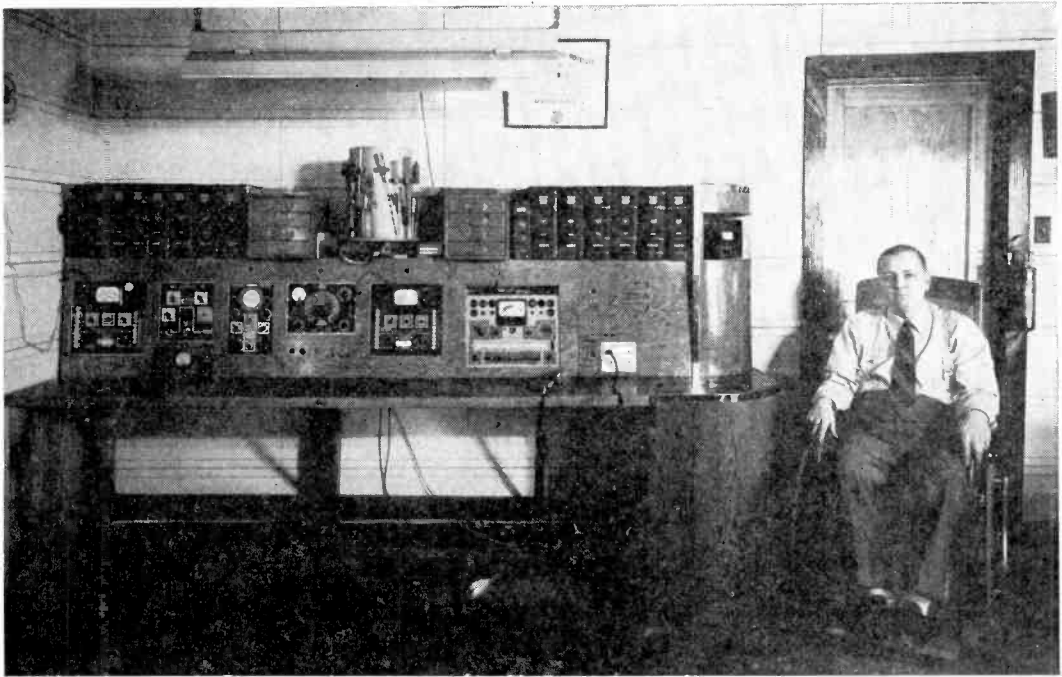

## STUDYVIN'S Radio Sales and Service

*Dear Mr. Smith:*

Although I have been unable to even stand on my feet for nearly 10 years and am in a wheelchair continually, I figure I have serviced approximately 6000 radios since Pearl Harbor. I am not bragging, just saying that it can be done, even though a person is physically handicapped.

We draw work regularly over a territory about 60 miles in all directions. We have grown in ten years from nothing to one of the largest Service Establishments in the Southeast part of Missouri and still hope to go forward. We attribute it largely to staying on the job and giving our customer's set the same service we would expect if we had our own set in the shop. We have a Motto in our shop which says, "A Square Deal to Every Customer."

I have my certificate of Registration with NRI here before me. It is dated February 8, 1935. Of course I would be forced to say that I knew nothing whatever about Radio until starting the NRI Course, and that first payment of \$2.50 was very hard to raise.

As my health was very poor, I didn't progress very well with my studies, and completed the

Course in somewhere around two years. I was handicapped on account of not having test equipment, making many of the various pieces of equipment in the Course of Instruction. You see I had lost my health and was worse than on the bottom. Since then, hard work and a determination to overcome difficulties has crowned our efforts with a small measure of success, as we have without question one of the largest repair Institutions in the Southeast part of Missouri. We are now beginning to branch out into the selling field.

To the young man who has ambition enough to stay with a hard job I suggest Radio Servicing, for I know money can be made at it. Our service methods are very different than most shops. We give any radio a complete going over. When that is done we give a ninety-day service guarantee. We make no extra charge if the set comes back for labor, charging only for any old part which may have gone out, replacing new parts which we replaced before free of charge. This honest service policy has paid rich dividends.

Yours Very Truly,  
ARLEY STUDYVIN,  
DeSoto, MISSOURI.

Page Fifteen

# How to Test Resistors and Condensers

BY LOUIS E. GARNER, JR.

Laboratory Instructor



Louis E. Garner, Jr.

**R**ESISTORS and condensers comprise the major portion of fixed components in radio receivers and defects in these cause the majority of troubles in sets (excluding troubles due to bad tubes). It therefore becomes necessary for the serviceman to be familiar with the troubles that can occur in these two components, their effect on reception and the proper techniques and methods to employ in testing these parts to determine defects.

Major defects in sets (such as burnt out power transformers, or tubes burning out rapidly) may be caused by a defect in a relatively inexpensive and easily replaceable part (such as a shorted condenser or a resistor which has changed in value).

Distortion, intermittent reception, hum and oscillation may all be caused by either bad condensers or resistors. A set may even go completely dead due to a fifteen or twenty cent part going bad.

General servicing techniques which you learn in your NRI Course will enable you to find the defective stage in a receiver fairly quickly, but it then becomes necessary to locate the defective part.

Study and experience will enable you to recognize the major troubles caused by bad resistors or condensers and to place your finger on the bad part after one or two simple tests. Replacement of that part will fix the set, but if the serviceman puts an unconditional guarantee on his work, it behooves him to test the majority of condensers and resistors in a set and replace

any which are not up to standard. This is to protect himself against losing time and money and possibly a customer on "comebacks." Unconditional 30 to 90 day guarantees are good practice because they build up customers' good will and attract new business. The best advertisement is a satisfied customer. To get and keep customers, you must be able to do good work, and do it quickly enough to assure yourself reasonable compensation for your time. In order to do this efficiently, you should not only know how to find the trouble in a set, but what will cause that trouble and what defects may occur so that cause-to-effect reasoning may be employed as part of your technique. Let us review some of the ways resistors and condensers may become defective.

A resistor may go bad by opening, in which case it acts as an open circuit, and by changing value. Overloading may cause a carbon resistor to open or change value; it may cause wire wound resistors to burn out. Mechanical strain can cause resistors to open and may cause wirewounds to change value—developing poor contact where the lugs are pressed into the resistance wire. Wire wound resistors may change value or short by having the insulation break down and adjacent turns of the resistance wire short together.

Condensers can develop similar troubles, plus a few that belong exclusively to condensers. They may open—one of the leads pulling loose; they may short due to dielectric breaking down; they may change value—due to aging or overloading. In addition, condensers may develop leakage, a partial breakdown in the dielectric which,

while not acting as a complete short, will cause the condenser to act as if there were a resistor in parallel with it, and high power factor—a condition which occurs most frequently in electrolytics and causes the condenser to act as if there were a resistor in series with it. These defects in components can cause many types of improper reception, depending on the exact nature of the defect, and the location of the parts in the set.

Practically all of the common complaints in radios may be caused by defects in resistors and condensers, and it would be impossible to list in a single article every possible trouble caused by bad resistors and condensers. Tables A and B illustrate some of the major troubles caused by bad resistors and condensers and may be referred to as needed—note, however, that these do not cover every possible trouble, nor can all the troubles mentioned be caused *only* by bad resistors or condensers. Further information on causes of receiver complaints will be found in the NRI Course.

In table A common resistors encountered in sets are listed in the first column, the defects they may develop in the second column, and the effect on the set in the third column. It is well to notice the many different troubles that such a simple defect as an open screen resistor can cause, and the importance of testing these parts to determine trouble.

Table B is analogous to table A but common condensers are listed in the first column, the usual type in the 2nd column, defects in the 3rd column and the possible effect on the receiver in the 4th column.

These tables will aid to some extent in locating the defective stage, but you should rely primarily on conventional testing methods which you learn in your NRI Course. After the defective stage is located, you may then apply specific test methods to locate the particular part. Here the tables will be of greater value. Testing the parts themselves and replacing the bad ones is the final step. Let us review methods for testing parts.

Resistors are the easiest to test with equipment commonly available and will be discussed first. Visual inspection of a set will give a good indication—if a resistor is damaged or appears to have been overheated—it is usually fairly safe to assume its value has changed and it may even be open. A mechanical test may be given to see if the leads have pulled loose. Burnt resistors and those with loose leads should be replaced as a matter of course.

A better test, however, is to use the ohmmeter of a multimeter such as the NRI Professional Volt-Ohm-Mil-Ammeter, Model 44, now being

manufactured and which will be available soon. (See Fig. 1.) Measure the actual value of the resistor as compared to the recommended value in the receiver diagram. For safety's sake, and to protect your meter, the power should be turned off by removing the plug from the power socket and all filter condensers discharged by shorting +B to -B with a screw driver. One side of the resistor being checked should be disconnected to avoid incorrect readings due to other parts being in parallel with the resistor. The ohmmeter test probes are touched to the resistor leads and its ohmic value will be read on the meter.

#### Resistors Can Be Checked For Continuity With A Voltmeter

A voltmeter may be used for checking your screen and plate resistors. If there is no plate or screen voltage—the resistor is open. (Assuming, of

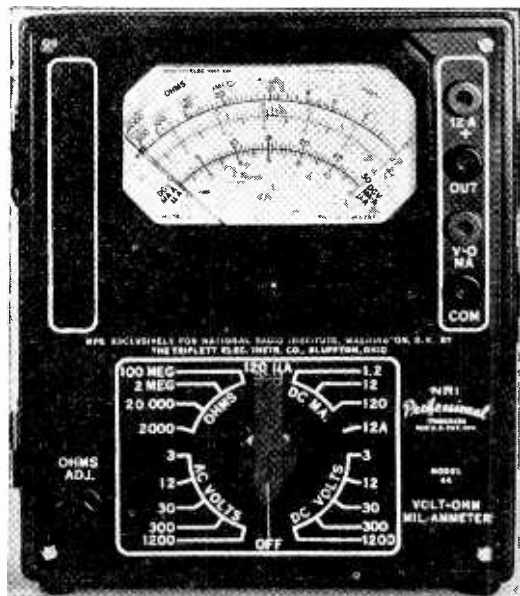

Fig. 1. A reproduction of the NRI Professional Volt-Ohm-Mil-Ammeter, Model 44. This instrument is now being manufactured for NRI, but a shortage of parts has delayed deliveries. Although none are now available, we are hopeful that some may be received soon.

course, that the power supply is working.) Be careful in making this test, however, for if the screen or plate resistor is of high value, then the drop due to loading by the meter may cause a reading to be low. A high resistance voltmeter (such as the NRI Model 44) should be used for

## TABLE A: RESISTOR TROUBLES

RESISTOR	DEFECT	EFFECT ON RECEIVER
Ballast or Line Dropping R	Open	Tubes don't light.
"	Short	Tubes glow excessively bright—burn out rapidly—may cause line fuse to blow.
"	Change Value	Tubes light too bright or not enough—depending on change; may cause signal to be weak—distortion.
Bleeder Resistor	Open	Cause screen or plate voltages to rise excessively—oscillation—possible breakdown of filter condensers.
"	Short	Low screen or plate voltage—heavy drain on power supply—may burn out rectifier tube or transformer or screen resistor—no signal.
"	Change Value	Either of above—depending on change—distortion—oscillation, weak signals, no reception.
Filter Resistor—sometimes used in place of choke.	Open	No B + voltage—set dead, input filter condenser breaks down.
"	Short	Hum—high B + voltage—distortion.
"	Change Value	Either or above—in less degree—depending on type of change and how much.
Plate Resistor	Open	No plate voltage on stage—set dead.
"	Short	Little stage gain, output signal weak, unusually high plate voltage.
"	Change Value	Either of above, including distortion.
Screen Resistor	Open	No screen voltage—set may be dead or signal weak and/or distorted.
"	Short	High screen voltage—may ruin tube—cause oscillation—distort signal.
"	Change Value	Either of above.
Cathode Resistor	Open	Set usually dead—cathode voltage may rise excessively—breaking down cathode by-pass condenser—distortion.
"	Short	Distortion—incorrect bias on tube—may introduce oscillation and motorboating.
"	Change Value	Either of above—degree depending on type change and amount.
Grid Resistor	Open	Motorboating—may cause set to go dead—if of high value may only cause distortion and hum.
"	Short	Kills signal at that stage—usually causes set to go dead.
"	Change Value	Either of above.
Diode Load	Open	Set may be dead or highly distorted.
"	Short	Kills signal.
"	Change Value	Either of above.



## TABLE B: CONDENSER TROUBLES

CONDENSER	USUAL TYPE	DEFECT	EFFECT ON RECEIVER
Line (117 v.a.c)	Paper	Open	Noise, hum.
"	"	Short	Blows line fuses.
"	"	Change Value	Usually little effect unless change is considerable.
Filter Condenser	Elect.	Open	Hum—distortion—if input condenser, low B+ voltage.
"	"	Short	Heavy drain on power supply—set dead—may ruin rectifier tube and burn out power Xformer.
"	"	Change Value	Hum—distortion—change in B+ voltage.
"	"	High Power Factor	Hum—distortion—lower B+ voltage.
"	"	Leakage	Low plate voltage—signal weak.
Output Tube Plate By-Pass	Paper	Open	"Tinny" sound due to harmonic distortion—set may oscillate.
"	"	Short	No plate voltage—output transformer may burn out—set dead.
"	"	Change Value	Decrease—similar to open. Increase—high notes lost—set "booms."
"	"	Leakage	Low plate voltage—signal weak.
Screen By-Pass	A.F.-Paper R.F.-Paper or Mica	Open	Oscillation—hum—distortion.
"	"	Short	No screen voltage—signal weak or set dead, screen supply resistor burns out.
"	"	Change Value	Oscillation—distortion—depends on change.
"	"	Leakage	Low screen voltage—signal weak or distorted.
Cathode By-Pass	A.F.-Elect. R.F.-Paper	Open	Degeneration—stage gain reduced—if common to two r.f. tubes oscillation results.
"	"	Short	Distortion—Incorrect grid bias.
"	"	Change Value	Increase—Little change. Decrease—Low notes lost—degeneration.
"	A.F.-Elect.	High Power Factor	Similar effect to value decrease.
"	R.F.-Paper	Leakage	Similar to short—some leakage is tolerable here.
Coupling Condenser	A.F.-Paper R.F.-Paper or Mica	Open	Set dead—very weak.
"	"	Short	Set dead—or heavy distortion—may damage tube or overload power supply.
"	"	Change Value	Increase—may cause oscillation. Decrease—signal weak.
"	"	Leakage	Distortion—in a.c.-d.c. receivers may damage rectifier tube—output tube may become gassy.

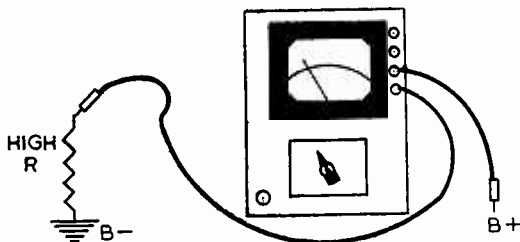

Fig. 2

this purpose. To reduce chances of error use as high a range as possible.

High value resistance such as grid resistors (10-20 megohms) may be checked for continuity by the method shown in Fig. 2. This method, while not giving an accurate value check, will test the continuity. If a voltage reading is obtained, there is continuity, if not, the circuit is open. The resistor should be disconnected from the grid of the tube when making this test.

It is often important, in checking resistors, to know accurately the ohmic value to within a fairly close tolerance. This is particularly true in certain voltage divider circuits, bass boost circuits, resistance phase inverters, and in certain FM and television circuits. In a case like this, the ohmmeter accuracy is not sufficient, and it becomes necessary to check the resistors on a bridge of some sort. A bridge is also useful in checking resistors whose value falls in the crowded section of the ohmmeter scale, where reading with accuracy is difficult.

The NRI Professional Model RC-111 tester is a combination resistor and condenser bridge and is ideally suited for this purpose, giving good accuracy on all ranges. (See Fig. 3.)

When using a bridge to check resistors, it is still necessary to disconnect one side of the resistor from the circuit, however, and it is advisable to remove all voltage from the set.

When using the RC-111, the leads from the resistance capacitance jacks are connected across the resistor, the range ("multiply by") switch set, and the central knob rotated for maximum eye opening. The reading on the dial is multiplied by the factor shown by the "multiply by" switch to obtain the ohms value. If the eye cannot be made to open, other settings of the range switch are tried. Should the value of the resistor be known approximately (that is, in the hundreds, thousands, or millions of ohms), the range switch may be set immediately.

The RC-111 tester is extremely valuable in testing condensers, too, and its use will be discussed after conventional testing methods are reviewed.

Electrolytic condensers usually fail more often than any other type. This can be due to drying out of electrolytic, or a breakdown of the dielectric by overloading. Electrolytic condensers which are not fully formed or which have been setting on a shelf for some time are also likely to go bad in service unless they are first formed. "Forming" an electrolytic consists of building up the dielectric, which consists of little bubbles of gas, by applying an increasing voltage up to the working voltage of the condenser and allowing this voltage to remain on the condenser until condenser leakage becomes normal.

Electrolytic condensers can change value, break down and become leaky or shorted, or develop high power factor.

A leaky or shorted electrolytic condenser will manifest itself in various ways, depending on its location in the circuit. (Refer to table B.)

Disconnecting one side of the condenser (after removing power) and shorting it out to remove a possible charge will prepare it for testing with an ohmmeter. Check the leakage resistance, allowing the reading to become as high as possible. (The meter will flick toward zero ohms and slowly go back to a high resistance reading.) If the reading is low, try reversing the ohmmeter leads to be sure polarity is right. (Since the electrolytic has polarity and a battery is used in an ohmmeter, it is necessary to get the polarity right, i. e. positive to positive). In order to get the correct reading on the Model 44 and the majority of multimeters—the red lead (*positive*) goes to the *negative* side of the condenser, and the black lead to the positive condenser terminal.) A reasonably high range should be used—say  $R \times 1000$  ohms—and if the leakage resistance measures more than 100,000 ohms it is reasonably safe to assume that the electrolytic is all right as far as leakage is concerned.

It is important to note, however, that this measured leakage resistance is not necessarily the value when operated at its working voltage—no simple way is available to make such a test with a multimeter but the RC-111 tester has provision for checking the leakage of electrolytics at their rated working voltage. Provision is also made for forming electrolytics, while leaving the rest of the tester available for checking capacity value and power factor or making resistance measurements.

Electrolytics may develop high power factor as well as leakage and act as if they had a resistor in series with them. This will cause the set symptoms shown in table B. There is no direct way to check for power factor without using an instrument such as the RC-111 tester.

If a condenser is suspected of having high power factor, or of having lost most of its capacity,



Fig. 3. This is a reproduction of the NRI Professional R-C Tester, Model III. These instruments are now in stock at NRI and available in limited quantity.

a substitution test can be made while the set is operating. You simply take a condenser known to be good and of the same rated capacity and working voltage (or higher) than the suspected condenser and place it in parallel with the condenser in the set—making sure of the polarity and being careful not to touch the bare leads with your fingers. If this corrects or partially corrects the complaint—the condenser should be replaced.

This method, while good, is dependent upon the set being in operative or partially operative condition. If the set is not working at all, you must rely on a tester like the RC-111 to check for low capacity and high power factor accurately, although an approximate measure of capacity of a condenser is given with the ohmmeter when you are checking leakage. The speed with which the pointer flicks toward zero ohms and the length of time it takes to reach a fixed reading will give some indication—the faster the meter flicks and the longer it takes to reach a stable reading, the larger is the capacity. This is only an approximate method, however, and the time will vary considerably with different ohmmeters, for the same capacity. Capacity power factors will also affect this test so that a bridge check is the preferred method.

Paper condensers will develop troubles similar to those encountered with electrolytics, but seldom develop high power factor. Their primary troubles are leakage, open, intermittently open, and changed value.

Leakage in paper condensers usually is on a

considerably higher order than in electrolytics. Even 20 or 30 megohms leakage in a coupling condenser may lead to distortion. Resistance values higher than this are quite difficult to measure with the average ohmmeter and you must rely on some other method to check leakage. The method used for checking high resistances may be used—see Fig. 4, in which a reading on the voltmeter indicates leakage. The meter range employed should be great enough to measure the B supply voltage directly (at the start) because C might be shorted. If the condenser is not shorted you can switch to a low range. Any reading even on the lowest volt-meter range indicates leakage.

If the condenser to be tested is the coupling condenser in a set (see Fig. 5, condenser C.) you may simply disconnect it at point X and measure the DC voltage from the condenser lead to ground while the set is operating. If any DC voltage is indicated, the condenser should be replaced. This test, however, requires that the power supply be operating and you must still rely on a tester like the RC-111 if the set is completely dead.

Paper condensers which change value and lose capacity or become open due to aging may affect reception considerably, the exact effect depending on their location in the set. (Refer to table B.)

An open condenser or one which has lost capacity may be tested by the substitution method previously mentioned; i.e., placing a known good condenser across it while the set is operating. This is an effective test for by-pass condensers and for most coupling condensers, but there are a few critical circuits where the condenser value

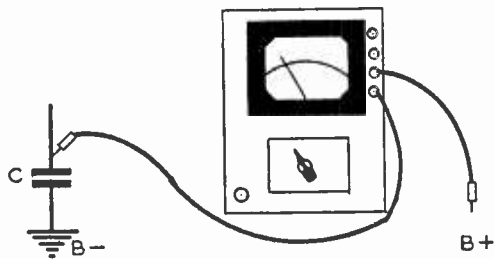

Fig. 4

must be fairly close to the value called for in the circuit diagram for good operation. As you gain experience and progress with your studies you will be able to see which condensers are critical as to value and act accordingly. This substitution test has the same limitations as previously mentioned, i.e., the set must be partially working.

Intermittently open condensers cause the major-

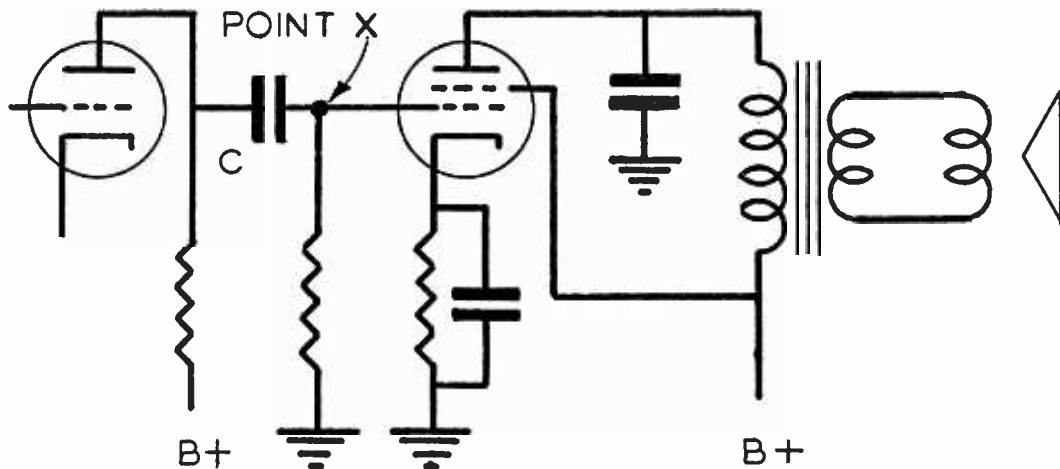

Fig. 5

ity of "intermittents." These condensers are occasionally hard to find, but in most cases can be found by the application of basic principles.

It is assumed, of course, that the set is operating, but that the complaint is intermittent operation. You then take a pair of pliers and wiggle each condenser. When you find one which will cause the set to stop operating, and which can be made to cause intermittent reception by wiggling, the condenser should be replaced. This "brute force" method is also applicable to finding loose connections and other causes of intermittent operation. It is, though simple, the best available test for this type of trouble.

This resumé of various testing methods may best be concluded by summarizing the material covered.

We have reviewed the basic defects that can occur in resistors and condensers and how these defects will affect radio reception. Tables A and B itemize these defects and their effect. The basic test procedures used by experienced Radiotricians have been outlined for making the various tests on these parts, and the RC-111 tester has been mentioned as an instrument capable of making accurate measurements of resistance and capacity with provisions for making many tests that can be made in no other way. It is well to note here that an instrument such as the RC-111 tester is of value not only in test and repair of radio sets but is especially valuable in making estimates. A rapid check for leaky condensers and those with high power factor and including the replacement of those in the estimated cost of repairing a set will often mean the difference between a satisfied and a dissatisfied customer,

between good and bad reputation, and between profit and loss.

In general, the radioman who prepares himself by study and work, and who conscientiously uses the equipment and techniques available to him, especially those specialized pieces of test equipment which speed up work considerably and at the same time improve the quality of the work, will find himself in a position to make a success of radio servicing as a business.

For further information on the NRI Professional Instruments mentioned in this article, write to Director, Supply Division, National Radio Institute, 16th and U Streets, N. W., Washington 9, D. C.

— n r i —

## IT HAPPENS EVERY MONTH

Perhaps you are among the writers of 41 letters or lessons received WITHOUT SIGNATURE OR ADDRESS during the month of February.

Perhaps you wanted information in a hurry and sent the inquiry by air mail—unsigned—from as far as Fairbanks, Alaska, or by regular mail from our own postal zone in Washington, D. C.

Perhaps you are wondering why you do not get a reply to your request for further information.

**DID YOU SIGN YOUR NAME AND STUDENT NUMBER BEFORE MAILING YOUR LETTER OR LESSON?**

# NEWS OF THE RADIO WORLD

BY

*H. L. Emerson*

**Television rights** for the 1947 home games of the New York Giants have been sold to NBC for \$50,000. A new technique, involving the use of from four to six television cameras, will be employed. CBS has exclusive video rights to the Brooklyn Dodgers games this year and DuMont to those of the New York Yankees.

**Thirty thousand cars** in the United States have already been outfitted with two-way mobile radio telephones—according to the Society of Automotive Engineers.

**General Electric** has developed a new, 15 pound electronic device for telemetering samples from 28 recording devices in the instrument section of a V-2 rocket. The information is transmitted to the ground from the 3800 mile-an-hour missile, and permanently recorded on film. Small in size—the device is enclosed in two metal cans, 4 inches in diameter, the one 12 and the other 15 inches long. Ten vacuum tubes are used.

**A capsule-size phototube**, baby brother of the phototubes which open doors at your approach, turn on drinking fountains when you bend down to drink, and operate animated electric signs, has been introduced by the RCA Tube Department. About the size of a .22 caliber long rifle cartridge, the new electron tube, designated RCA-1P42, is the smallest phototube ever offered commercially.

**Special television receiving licenses** are forecast for Canadians by Mr. Gordon Olive, Chief Engineer of Canadian Broadcasting Corporation. CBC has planned five television stations in Canada, the first to be located in Montreal.

**Before the war** there were approximately 60,000 licensed "hams." This figure has now risen swiftly to 75,000. If the present rate of new applications reaching the FCC continues, a total of around 100,000 licensed radio amateurs will be "on the air" two years from now.

**A new electronic fire alarm** uses a photocell which is sensitive to the ultra-violet rays emitted by flames. A special filter makes the photocell insensitive to ordinary light, though it reacts to a fire in a few seconds. Heat-operated fire alarms usually require several minutes before the alarm is cut off.

**A new "Radio Paging" service** has been licensed

on an experimental basis by the Federal Communications Commission. In New York, The Telephone Answering Service has received permission from F.C.C. to erect a high-frequency transmitter in order to establish a radio message service. Messages, as a result, may be sent to persons sitting at a ball park, theater, etc. Subscribers to the service would receive a small portable receiver upon entering a theater, as an illustration, and listen for a code number by bringing the set to the ear. The receiver, about one and a half times the size of a package of cigarettes, would be audible only to the subscriber.

**Billboard Television** is being studied by a large New England outdoor advertising concern. Present billboards are at a disadvantage because copy cannot be changed readily. Television technique would make them literally up-to-the minute.

**Two-way Radio** for passenger buses is to be installed in the Chicago area. A communication company will place equipment in coaches of several bus lines to permit contact between the terminal and buses within a radius of about 75 miles.

**The new auto Radio plant** of RCA Victor has started production in Chicago. It is the first plant in the country devoted exclusively to the manufacture of automobile radios and is RCA's first factory in the Chicago area. The new plant, with 160,000 square feet of space, an expected personnel of 700 employees, will eventually be a completely self-sustaining factory for the manufacture of radios for the automobile industry.

**Singing Commercials** are indirectly banned from the Argentinian ether waves. Unable to discriminate against the singing as opposed to the spoken commercial, the Argentinian version of the F.C.C. simply clamped down a rule against all recorded commercials. Without recordings, singing commercials are impractical.

**The DuMont Electronic Viewfinder** is a feature of new DuMont Television cameras. With it, the operator can meet changing conditions instantly, countering excessive light, focusing continuously, centering and framing his pictures independently of a mechanically controlled optical system. With this new equipment, he can obtain the iris control needed for field pickups of high quality. No adjustment is required for the telephoto lens.

# ELECTRIC GUITARS



Fig. 1. Photo through the courtesy of The Amperite Company, 561 Broadway, N. Y., N. Y.

Students have shown an interest in electric guitars and as a result some information on the subject is presented here to meet the demand for technical data.

Fig. 1 shows a typical electric guitar pickup, attached to a guitar. This is the Amperite "Kontak" mike. Essentially, it is a pressure operated contact mike, of the dynamic type. The musical vibrations are transmitted to the pickup which transforms the sounds into electrical signals.

The signal voltage is applied to the input circuit of an audio amplifier. This is illustrated in block diagram fashion in Fig. 2. As we can see, the audio amplifier feeds into a loudspeaker which reproduces the original sound, but with much greater intensity.

Special audio amplifiers designed expressly for electric guitar service are commercially available. Typical is the Gibson EH-150 shown in Fig. 3. Because of the fact that voice announcements often are necessary in practical work (where the guitar is used for public entertainment, in a nightclub, restaurant, etc.), it has provisions for voice mike operation. That is, operation of a

mike that is used to pick up the voice of a singer or announcer.

In Fig. 3 a crystal high impedance mike may be plugged into the microphone jack. The crystal mike is usually fitted with a shielded cable. The end of the cable is fitted to a plug which is inserted in the microphone jack.

In a similar way, the Kontak mike may be connected to the amplifier. The Kontak mike plug is inserted in one of the "instruments" jacks. Two such mikes may be plugged into this amplifier.

Because of the fact that the voice mike delivers less voltage than the guitar mike, additional



Fig. 2

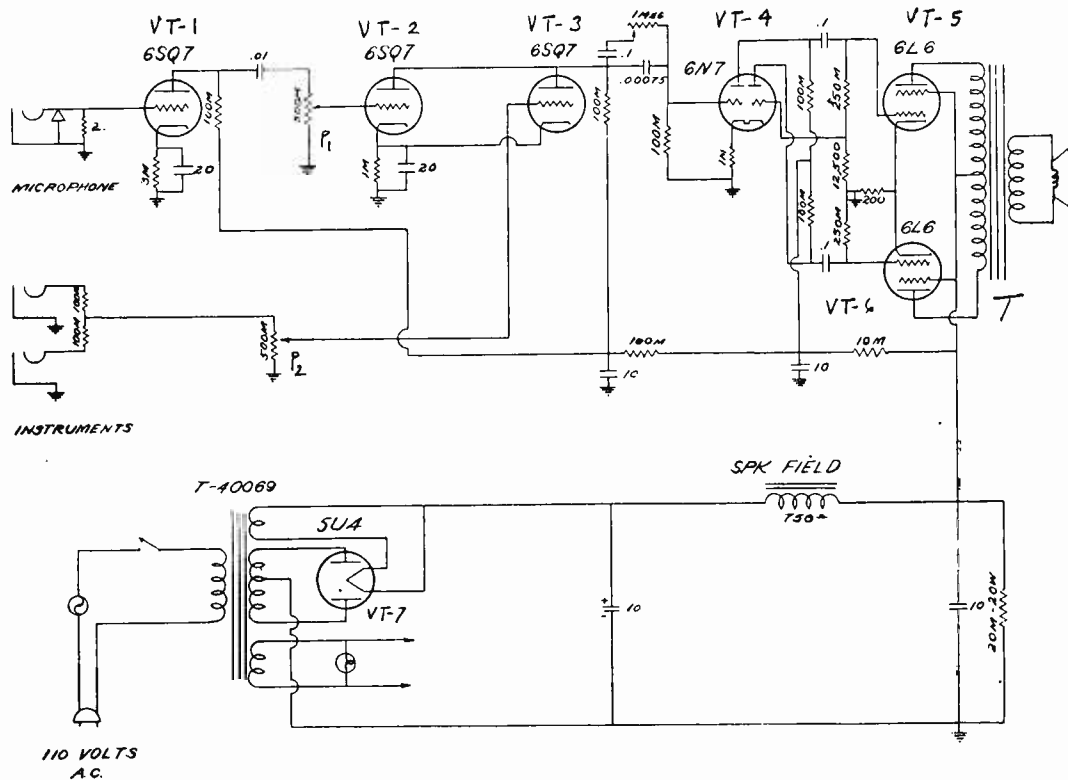

Fig. 3. Circuit diagram of a typical electric guitar amplifier. The Gibson EH-150 is manufactured by Gibson, Inc., Kalamazoo, Mich.

amplification is necessary. Hence, an additional 6SQ7 audio amplifier is used for voice mike operation.

The output of the mike pre-amplifier is fed to the 500,000 ohm potentiometer in the grid circuit of VT-2. Potentiometer  $P_1$  controls the voice mike level and  $P_2$  controls the guitar level. The output of VT-2 and VT-3 is fed to VT-4 which is a 6N7 functioning as a voltage amplifier and phase inverter.

The signal is fed from the plates of VT-2 and VT-3 to the 6N7 grid through a .00075 mfd. condenser and through the parallel circuit consisting of the .1 mfd. condenser in series with the 1 megohm variable resistor. When the 1 megohm control is adjusted to its maximum resistance value, the tone is high pitched, since the signal must pass through the .00075 mfd. condenser. As this condenser is small in value, it passes the "highs" but attenuates the "lows."

The tone may be "deepened" by reducing the resistance in series with the .1 mfd. condenser. The condenser then becomes more effective as a shunt across the .00075 mfd. unit and the circuit passes the "lows" with less attenuation.

The VT-4 stage drives the 6L6 tubes which are in push-pull class A in the output stage. These tubes furnish signal power to the loudspeaker through output transformer T. The loudspeaker then reproduces the sound.

Power for operation of the plates and screens of the various tubes in the amplifier is supplied by the heavy duty 5U4 rectifier tube.

The tone quality of an amplifier of this kind is quite good. As adequate reserve power is available due to the use of powerful 6L6 tubes, bass peaks can easily be handled. Also, because the amplifier is usually operated at less than rated output, hum and distortion are reduced.

# A Live Wire NRI Man Now With A Live Wire Firm

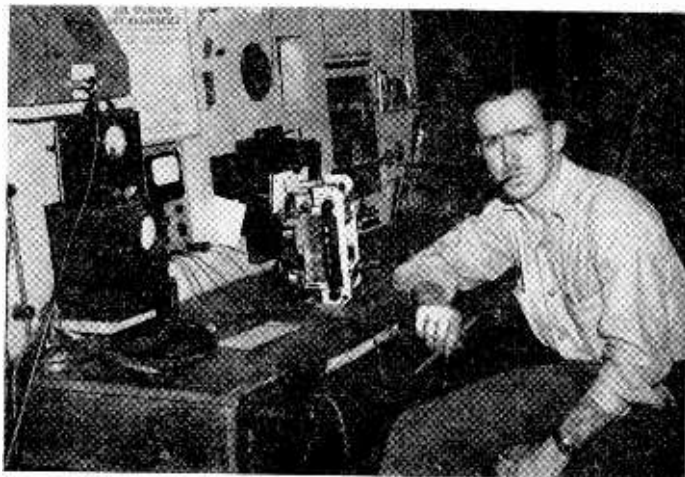

E. E. Baldwin at his bench

*Dear Mr. Smith:*

After discharge from the Navy, I started my own business. I did O.K., but have now closed my shop to accept my present job which pays still better.\*

I easily passed the amateur license test, and now possess a fine 100 watt station, WRUG. It is a dandy hobby and one meets some mighty nice fellows on the airwaves. YL's too!

We have the Harvard (Neb.) Radio Club, with Keith Stevens (An NRI man), Paul Gardner, and Hank Miller as full members. Small, but lots of fun.

Art Sigel, one of the owners of "Radio-Electronics" has both a commercial and amateur ticket. Walt Tiffles and myself have tickets, making three hams in the business.

I am employed by the firm called "Radio-Electronics," of Hastings, Nebr. Needless to say, it is a great pleasure working for such a modern, progressive firm. We sell Victor, Decca, Capitol, and Columbia records. Have four private, air-conditioned booths to aid listeners in selecting their favorite records. Appliances handled by this firm include G.E., R.C.A., Crosley, Sonora, and others. We sell, rent, and install P.A. systems and intercoms.

An interesting sideline is professional recording. We make records for anyone, using all modern equipment.

Advertising includes an all-request program "Musical Grab-Bag," over station KHAS, Hast-

Page Twenty-six

ings, Nebr., daily from 10:30 P.M. 'till midnight. People must stay up that late, for we get over 1500 requests per month.

Now for the service end! Our aim is *quality first*. We handle about five hundred sets per month, including maintenance of the local police and commercial F.M. systems. We also have the Crosley warranty authorization, and serve 200 Crosley dealers in Nebraska and surrounding states. The Crosley Corp. has recommended us for our work.

Most of my equipment has been acquired since the end of the war. In the upper left is a home-made signal tracer, and in the center a home-built signal generator, covering both A.M. and F.M. Panel includes test speaker to match any radio, and in the hole there is now an intercom to the next bench, as well as to the sales counter.

As my employers say—"It's not the pretty equipment, but the knowledge and experience that really counts." NRI helped me to get that and I recommend the Course to anyone *honestly* wanting to learn radio. I took both the Servicing and Communications course, and both were very good.

Extra information on our store appears in December, 1946, issue of "Radio and Television Retailing." Look for big things from the firm "Radio-Electronics." While I only work there, I've a big interest in the business and know it's going places.

Yours for continued success,  
E. E. BALDWIN,  
Harvard, Nebraska.





# N.R.I. ALUMNI NEWS

Frank Zimmer .....	President
Ernest W. Gosnell .....	Vice-Pres.
Harry R. Stephens .....	Vice-Pres.
Chas. J. Fehn .....	Vice-Pres.
Harry Andresen .....	Vice-Pres.
Earl Merryman .....	Secretary
Louis L. Menne .....	Executive Secretary

## NEW CONSTITUTION AND BY-LAWS IS ADOPTED BY OVERWHELMING MAJORITY

More Than 99% Vote For Approval

THE National Radio Institute Alumni Association has a new Constitution and By-Laws. The members have approved it by a vast majority.

The interest in the question of adopting or not adopting the proposed Constitution and By-Laws was very gratifying to our Alumni Officers. The matter has had long and careful consideration and we are glad to have so many of our members approve our efforts to clarify a number of points either not covered at all or not clearly stated in our former Constitution and By-Laws.

More than a year ago it was decided that something would have to be done to bring our Constitution and By-Laws up to date. The matter was discussed with Alumni members whenever the opportunity presented itself. It was discussed at Alumni Chapter meetings, it was written and rewritten. It was then submitted to legal counsel for careful study and examination.

Next it was set in print and submitted to each member together with a ballot for him to vote "yes" or "no" on its adoption.

A total of 3721 members cast their votes. Of this number 3673 voted in favor of adopting the constitution and 34 voted not to adopt it. Un-

fortunately 14 ballots were disqualified because the voters either failed to sign the ballot or failed to mark their vote, "yes" or "no."

According to the old Constitution and By-Laws, if 75% or more of those voting are in favor of a proposed amendment to the Constitution the proposal shall be declared adopted. The results of our voting show 3673 of a total vote of 3707 in favor. This is slightly more than 99%. Therefore the new Constitution and By-Laws are officially adopted as of midnight March 15, 1947 when the polls were closed.

This new Constitution and By-Laws now in effect enables us to better administer the affairs of the NRI Alumni Association. The old Constitution and By-Laws was adopted in November, 1929 at the time the NRI Alumni Association was organized. It served us very well for all these years but, like other things, it needed bringing up to date to meet current conditions. That was our reason for asking for a new Constitution and By-Laws.

Once again we want to thank our members for their sincere interest in this proposal. The changes were very necessary and will enable us to handle our affairs in a more efficient manner. We have taken another forward step.

## New York Chapter

We have just purchased a new RCA Demonstrator Board and hope that this attraction will help increase attendance.

At our February 13 meeting, James J. Newbeck gave a fine talk on the circuit used in the "Demonstrator." All of the members present were well satisfied with this new piece of apparatus, and we expect to get a lot of use from it. "Dynamic Jimmy" continued his talk on the same subject at the following meeting.

At a recent meeting our National President, Frank Zimmer, gave a very inspirational talk. We are all happy that Frank has been elected. Not a finer fellow could hold the highest office in our great organization. At the following meeting we held a little "social" in honor of President Zimmer. As he always is doing, Frank bestowed honor on someone else by introducing August Wagner and Lou Kunert as the two oldest members of our Chapter. (We hope to supply photos of this social event for the next issue of NR News.)

Alex Remer has been giving a series of lectures on electricity. This fellow Remer is developing into a fine speaker, and his lectures were very good. At our last meeting he conducted a Radio Quiz, which proved very popular.

The "Question and Answer Forum," conducted by our Vice-Chairman Pete Peterson, continues as one of the most looked forward to events of each meeting. Pete always passes out good information, and is so entertaining.

To give credit where credit is surely due, still more appreciation is due to Jimmy Newbeck, for, in two other meetings, he delivered excellent talks on "The Theory of Detectors." His talks are always great—so thorough and easy to understand.

Member Phillip Spampinato has developed a new kind of cradle for use in aligning receivers with loop antennas. By the way, both Spampinato and Morris Friedman are in need of cradles—of another type. (Proud Fathers!)

George Hirsh has been succeeded on our Executive Committee by Richard Patten. We thank Mr. Hirsh for a grand job and hope he will soon be able to attend regularly again.

Attendance has been good, averaging over fifty present, except at one of the last meetings. Due to the heavy snow storm, our attendance dropped to forty. "Richard" Patten "opened the door" by jumping in at the last moment and speaking on "Extending the Range of D.C. Meters." Eugene Williams, scheduled to speak on that subject was "snowed in." The same night William Fox gave an outstanding discourse on his radio servicing experiences.

Page Twenty-eight

The Executive Committee plans a mailing campaign to let the fellows know about the new Demonstration Board. This should help further increase our attendance. We set aside the first and third Thursday of each month for our meetings at St. Mark's Community Center, 12 St. Mark's Place—between 2nd and 3rd avenues, New York City. Time 8:15 P.M.

LOUIS J. KUNERT, *Secretary*  
145—20 Ferndale Avenue  
Jamaica 4, New York.

— n r i —

## Phila.-Camden Chapter

Since our last report we have installed our 1947 officers and are well settled in our new meeting place.

Highlighting one of our recent meetings was a talk by our new Chairman, Harvey Morris. Harvey is known to us as "The Wizard" on repairing radios. We are adopting Harvey's suggestion to review one lesson of the NRI Course at each meeting, commencing with Lesson 5, on Resistors. With the aid of schematics on the blackboard, we expect to go places in 1947.

We sincerely urge all members to attend, and all students and graduates to come and join in with us. Just get off the Frankford "El" at Orthodox St., and walk a few steps to No. 4510 Frankford Ave., 3rd floor. Meetings are regularly held on the second and fourth Monday of each month. A swell crowd awaits you in a swell meeting hall.

CLIFFORD N. HILL, *Recording Secretary*  
1317 N. Alden Street  
Philadelphia 31, Penna.

— n r i —

## Detroit Chapter

So that our Chapter's progress and expansion may continue, we are already busy deciding on speakers and programs for the 1947-1948 season. Prospects for membership enlargement seem unusually good. Chairman Earl Oliver is doing a grand job. A full and interesting program awaits all NRI Students and Graduates in this area who are not yet attending our meetings.

Plans for our annual big party for June 18 are nearing completion. All members should keep this date in mind and plan to attend.

Some excellent films have added greatly to recent meetings. "The World's Largest Electrical Shop"; "The Life of Thomas A. Edison"; and Parts 1 and 2 of "Excursions in Science" were among films shown at two meetings. At a following meeting Parts 3, 4 and 5 of "Excursions in Science" were shown. The five reels on "Excursions in Science" were furnished to us through the courtesy of the General Electric Corporation.

Chapter member Robert Mains delivered an excellent talk on "The Oscilloscope" several meetings ago. We are always interested in discussions of modern equipment and its use, and appreciate his fine talk.

Four new members have joined our ranks. They are: Frank Caballero, Walter E. Crafton, Stanley G. Hasler, and Harold T. Boring.

We are indeed proud of our new meeting place at 21 Henry Street, corner Woodward Avenue (second floor). Attendance of all NRI men is invited. Remember the date—first and third Fridays of each month.

HARRY R. STEPHENS, *Secretary*  
5910 Grayton Road  
Detroit 24, Mich.

— n r i —

### **Peter J. Dunn Dies Suddenly**

From Vice President E. W. Gosnell comes the sad news that our beloved friend Pete Dunn died on February 12, 1947, from a heart attack. He was 54 years of age. He was found in his quarters in San Francisco, where for some years he had been doing government work. Burial was in Baltimore.

To know Pete was to like him. His was a pleasing personality. He was very popular with our Alumni members.

Pete Dunn was President of the NRI Alumni Association from 1935 to 1939. He also served several years as Vice President. After serving four consecutive terms as President it was Pete who advocated an amendment to our Constitution and By-Laws limiting the term of office for the President to one year. Always thoroughly interested in our Alumni Association, Pete agreed that it was only fair to give other faithful workers the opportunity to move up. That was Pete Dunn. Always loyal—never selfish about anything.

We had been looking forward to his return to Baltimore and our Chapter there, for which he did so much, as a Charter member and as Chairman for several years.

We will miss Pete Dunn. He extended a helping hand to hundreds of fellows in his day. He was a regular fellow—a right guy.

## **Baltimore Chapter**

We are very proud of our Past Chairman Ernest W. Gosnell for having been reelected Vice-President of the National Alumni Association for 1947. It was also nice to have Mr. Gosnell install our new officers for 1947. Discussions at this same meeting included "F.M. and A.M."; "Crystals"; and "New Types of Refrigeration."

Greatly adding to the interest of another meeting were two reels of movies entitled "On the Air" and "Electronic Tubes at Work." Mr. Butler, one of our members, is employed by Westinghouse, and made arrangements for the loan of these two films from that firm. We appreciated this a lot, and were also glad to have Mr. William Parnell, of Westinghouse, with us as Mr. Butler's guest. Another visitor was Mr. George McDaniel an NRI Student from Washington, D. C.

Four new members have been accepted for membership in our Chapter. They are: Charles W. Hundermark, Albert E. Klein, John Loinesak, F. M. Martin. We greet these new members and hope they will find much in Baltimore Chapter that is interesting. Two other NRI men, Samuel P. Chalfont and Norman McClelland, visited one of our recent meetings. We look forward to these two men finding our meetings of sufficient interest to join us. We are proud of our Chapter member, Mr. Whitt, who gave a very good talk at the last meeting. His subject was "Average Peak and Effective Voltages." He proved very capable, and brought forth considerable interest and discussion.

By the time this issue of NR News goes to press, we will have had our Semi-Annual party, which is scheduled for March 11. We are looking forward to having most of our members present, as well as any friends from National Headquarters who are able to attend. Plans include a regular business meeting at Redman's Hall, and adjournment to Baker's Tavern at Broadway and Oliver Street.

It is with great regret that we record in our minutes the death of Mr. Peter J. Dunn, Charter Member and the first Chairman of Baltimore Chapter, as well as Past President and Past Vice-President of NRIAA. "Pete," as he was fondly called, was always active in his Chapter and our Association. We have set aside a page in our Minutes Book as a tribute to his unflinching interest.

Our meetings are held on the second and fourth Tuesday of each month at Redman's Hall, 745 W. Baltimore Street, in Baltimore.

P. E. Marsh, Recording Secretary  
Box 2556, Arlington Sta.  
Baltimore 15, Maryland

# A Message From Our 1947 Alumni President

## Frank Zimmer

### NRIAA - 1947

To be chosen for any office in our organization is certainly a compliment. But to be elected for the highest post in our organization is indeed a most generous vote of confidence.

In proudly, happily and, of course, thankfully accepting this office permit me to express the wish that every member, particularly those connected with local chapters, put their shoulders to the wheel with me during the year 1947 in an effort to considerably further our Alumni Association as an organization and members as individuals.

To those who are members of Chapters, I would like to say that by helping your fellow members in every possible way, an increase in membership in your chapter is bound to result. To those in the great majority who do not have chapter affiliations I ask that they cooperate in every possible way toward helping their fellow members and radio men wherever they may find them.

The National Radio Institute has been a blessing to many of us. It has given us a means by which we were able to acquire a complete understanding of radio principles through the privilege of studying in our own homes. Many of us, who were not in position to attend resident schools, otherwise would have been denied this great opportunity to learn radio and engage in the work on a full-time or part-time basis.

Our Alumni Association now has a membership of more than 6500. This growth is not due to the efforts of any one man or any small group of men. It is a natural development because of

an increasing number of graduates of the National Radio Institute. The foundation upon which this organization was buildied is so sound we were bound to experience a rapid growth.

However, no little credit for the expansion of our organization is due those who guide the affairs of our Alumni Association at headquarters in Washington.

At this time let me urge those, who still have the thrill of graduating, to apply themselves diligently to the study of their lessons. Let nothing interfere with your plan and program to study your lessons on a systematic basis so that you are making steady progress towards your goal—receiving your diploma. In my experience I have known NRI students who have completed one-half or three-quarters of the course and then felt they knew enough about radio so as to make it unnecessary to do the remaining lessons. These men started doing spare-time radio work and found themselves so busy, in their imagination, that they could not devote the necessary time to the study of the lessons. That is a serious mistake. Nothing should interfere with your study program. Let me urge that as forcefully as I can. Go on to your reward which is to graduate and then join the NRI Alumni Association and be one of us.

Again . . . with gratitude in my heart for your confidence in me, let me ask every member of the Alumni Association to remain enthusiastic and cooperative in every way whenever possible to lend a hand toward making 1947 another grand achievement year in the field of radio.



Frank Zimmer



## Here And There Among Alumni Members

Carl E. Stauth, owner and operator of "Radio and Electric Service," Corydon, Indiana, has an interesting sideline from his regular business. He has been re-conditioning small, five-tube sets and then mounting the chassis in twenty-one-inch arm-chair type cabinets. He has fifty-three of these receivers out to date, and makes a nice profit on each one.

Graduate George W. Millington, has a spare-time Radio business going full blast. Millington is from Balboa, Canal Zone.

Alumnus R. M. Miles is going places in the radio service business under the name of "Miles Repair Shop," located in Loyal, Wisconsin. He has just constructed a new building and owns \$4,000 worth of equipment besides \$2,000 in stock. Fixes almost anything electrical.

Now with the Westinghouse Electric Supply Company of Raleigh, North Carolina, Mr. Wiley M. Bryan is getting along wonderfully. He speaks of a possible promotion to take over the Radio Sales Department.

David J. Collier, of Perry, New York, has spent the winter in a house trailer in Oregon. We'll bet he's glad spring is finally here!

Baltimore Chapter member, C. M. White, has just received his first-class' phone ticket. Congratulations!

A Canadian veteran of the RCAF, Mr. Harvey Girard, has re-joined the service with his original rank. He is now engaged in radar landing research, which sounds plenty technical.

Graduate Theodore Klett, formerly with Station WWSK, in Northern Vermont, has accepted a position as Engineer-Announcer for a broadcasting station in Southern Georgia. We hope you like it down South.

We were sorry to hear the news that Alumnus Donald B. Nickerson, Kennedyville, Maryland, was accidentally killed on February 23, 1946. Mr. Nickerson will be missed by many friends.

"Elaine" is the name of the new daughter at the Fritz G. Fischers, in Minnedosa, Man., Canada. Elaine weighed six pounds and two ounces at birth.

We're glad to hear about Andrew Curtis' new position as Radio Service Manager for the Butterworth Furniture Co. of Hopewell, Va.

Leslie Sparks, Irondale, Alabama, has an interesting job with Southern Bell Telephone Company in their Mobile Radio Telephone division. Sounds like a swell opportunity.

We received an interesting letter from Elliam Grimshaw, of North Andover, Mass. He included a photograph of a home-made electric guitar and amplifier which he has constructed.

From Albuquerque, N. Mexico, Mr. O. B. Miller is now with Radio Station KOAT, as an operator-engineer.

Mr. Hoyte Moore, first Vice-President of the NRI Alumni Association—elected in 1929 at the time the Alumni Association was founded, has just been re-elected as Senator to represent Marion County in the Indiana State Legislature.

After finishing a six-year "cruise" in the Navy, Graduate George Deroko, of Central Village, Connecticut, has now started a spare-time Radio business. Here's wishing you success.

Another NRI man entering the broadcasting field is Stanley C. Leek, Jr., an Ex-Navy Radio Technician. He is with Station WASL, Annapolis, Maryland.

F. Stuart Godfrey reports that "Godfrey's Radio Service", St. Johns, Michigan, is doing very well. His letter mentions that another NRI Alumnus, William Mueller, is now working with him. Incidentally, Mueller has a "ham rig" ready to go on the air.

Recently discharged from the Army, Ralph S. Harrison, Barnesville, Ohio, has resumed business under the name of "Harrison Radio Laboratory." He services home receivers, auto sets, police and emergency equipment. Harrison also has an amateur station, call W8FYV.

Wilbert Baumgardner of Hubbard, Ohio, tells us that besides having a good spare-time Radio service business, he is a Lieutenant in the Civil Air Patrol, and has his own plane equipped with a General Electric two-way Radio. He plans on an amateur ticket soon.

Graduate A. B. Carraway, formerly of Sopchoppy, Fla., has now expanded his Radio servicing business by establishing a new \$10,000 Radio Sales and Service Store in Port St. Joe, Fla. He still operates his other store in Sopchoppy.

Good news from F. G. Sealy, Vacaville, Calif. He now has a permanent Civil Service status as Assistant Foreman, U. S. Air Corps. Radio Maintenance, at an AAF base in Fairfield, Calif.

## Chicago Chapter

We feel confident that our Chapter is headed for real accomplishment during coming months. Cooperation and interest of members is increasing with each meeting.

New officers elected for 1947 are:

Chairman ..... Steve Boguar  
 Secretary ..... Louis Brodhage  
 Treasurer ..... Lloyd Immel  
 Sergeant at Arms ..... E. Nelson  
 Librarian ..... Art Freres

Our former Chairman, Harry Andresen, held this responsible post for several years, and guided our Chapter through the turbulent war years. This year Harry insisted on making room for new talent. His resignation was regretfully accepted, and all members wish to extend their thanks for the assistance Harry has given. We're glad to be able to count on him for future advice.

At the present we are able to hold only one meeting each month—on the second Wednesday in the month. We want very much to set up a definite two meetings-per-month schedule, but, until a better meeting place is found, we must go along as we now are. All suggestions for a more suitable store or hall will be appreciated.

Meeting activities have included several "specials." Harry Andresen conducted one, a half-hour radio quiz. Our new treasurer, Mr. Lloyd Immel, gave a very worthwhile talk on "Home Radios, Their Ailments and Cures." Several "sick" radios were brought to meetings and sent home "cured."

Until further notice, meetings will continue at 2759 S. Pulaski Road, on the second Wednesday of the month, at 8:15 P. M. NRI men in our area are always welcome.

L. Brodhage, Secretary  
 4820 N. Kedzie Ave.  
 Chicago 2, Illinois

## The Mailbag!

For years we set aside a page in NR News for letters to the Editor. We called the page "The Mailbag." It was very popular.

We want to resume this page. Your comments and suggestions regarding our feature articles will be very welcome. Do you like the articles? Feel free to express any criticism. We want *your* views. Constructive criticism is helpful. We appreciate compliments, but the Editor does not want a pat on the back unless you think he deserves it. What he does want is your frank judgment regarding the type of articles we print. Do you understand them? Are they instructive, informative, beneficial? How can they be improved? What would *you* prefer? Come on, let's have it straight from the shoulder. You can help us help you! Address letters: Editor, NATIONAL RADIO NEWS, 16th and U Sts., N.W., Wash., 9, D. C.



FROM N.R.I. TRAINING HEADQUARTERS

Vol. 12

April-May, 1947

No. 8

Published every other month in the interest of the students and Alumni Association of the

NATIONAL RADIO INSTITUTE  
 Washington 9, D. C.

The Official Organ of the N. R. I. Alumni Association.  
 Editorial and Business Office, 16th & You Sts., N. W.,  
 Washington 9, D. C.

L. L. MENNE, EDITOR  
 J. B. STRAUGHN, TECHNICAL EDITOR

NATIONAL RADIO NEWS accepts no paid advertising. Articles referring to products of manufacturers, wholesalers, etc., are included for readers' information only, and we assume no responsibility for these companies or their products.

## Index

Article	Page
Editorial .....	2
Crystal Pickups .....	3
A Miniature Selenium Rectifier for Home Receivers .....	10
Our Cover Photo .....	12
Service Sheet .....	13
How to Test Resistors and Condensers .....	16
News of the Radio World .....	23
Electric Guitars .....	24
Alumni Constitution Adopted .....	27
Alumni Chapter News .....	28
Message from Alumni President .....	30
Here and There Among Alumni Members ..	31