

# NATIONAL RADIO NEWS



## IN THIS ISSUE

How to Remove The Chassis From Cabinets

Basic Principles in Resistance Measurements

Alumni Association News

APR.-MAY  
1946

VOL. 12  
NO. 2



## INITIATIVE

The man who does only the routine tasks, the ordinary jobs in his profession, always waiting for the other fellow to take the lead, can expect only moderate returns for his labors. He who is continually on the alert to grasp each new opportunity—gets the greatest profits. The immediate financial returns from work in a new and specialized branch of your profession may not be great, but the reputation which you gain for progressiveness will soon result in more profitable routine jobs. It all boils down to these simple facts—you must do out-of-the-ordinary things, stand above the crowd in some way, to attract favorable attention. People remember you first for the unusual, then for your ability to do ordinary work well.

J. E. SMITH, *President.*

# How to Remove the Chassis from Cabinets

By Don E. Quade

NRI Instruction Department



Don E. Quade

**A**LMOST every time you repair a radio, you will have to remove the chassis from the cabinet to locate and replace the defective part. In some receivers (particularly small portables), you must even do so to remove the tubes for testing. Now, removing a chassis may seem to be a simple job—yet, even when you know how, “pulling” the chassis can easily take longer than the actual repair!

In this article, I shall give you practical hints on how to remove the chassis rapidly. Study this information carefully—it will help you to service *faster and better*.

## General Procedures For Removing The Chassis

There are three types of cabinets: the midget, which includes the portable; the table model, a receiver of medium size that is set on a table or bench; and the console, a big cabinet that stands on the floor and may also include a phonograph. I will take up each type in turn. But, before I do, let's learn some general procedures that apply to all three.

Before you attempt to remove or reinstall a chassis, *always unplug the receiver power cord from the power outlet to prevent the possibility of shock*. Then take a few minutes to look over the receiver and study its arrangement. Usually, the fastenings will be simple.

As your first step, remove the control knobs. (These knobs fit on the ends of the control shafts which come from the chassis through the front panel of the cabinet.) The exact method of re-

moval depends on the fastening; some knobs have set screws; others are held on by friction springs. Just pull off the latter type. Further examination will show whether you must remove push buttons, dial pointers, etc.

Next, turn the cabinet around and look for speaker cables, power wires, antennas, etc., that have to be disconnected. Sometimes you will find it more convenient to disconnect these after the chassis has been wholly or partly removed from the cabinet. Some receivers have back covers or loop antennas that must be removed.

Next, locate the chassis fastenings. There should be screws or bolts holding the chassis in the cabinet, and sometimes shipping bolts or clamps used to protect the receiver in transport from the factory may still be in place. (On the other hand, a serviceman previously there may have left off the securing bolts, so be sure never to tilt a cabinet until you are certain that the chassis is securely fastened in it.) Most sets have a straightforward arrangement of two to four screws or bolts, but some have “hidden” screws. Sets with inclined tuning dials, or those in period style console cabinets, sometimes have extra screws holding the tuning mechanism in place.

Once you have located the fastenings, remove them and lift the chassis out of the cabinet. If it sticks, *do not force it*. Pull and lift cautiously to learn where it is being held. Many sets stand on rubber “feet” or blocks, which are used to reduce vibration. These blocks may stick, particularly when placed in counter-sunk holes, and will have to be pulled or pried loose.

Let's sum up the steps I have mentioned in removing a chassis:

1. Unplug power cord.
2. Remove control knobs.
3. Remove push-button knobs *if necessary*.
4. Remove dial pointer, dial scale, or dial cord connection to pointer *if necessary*.
5. Remove back cover or loop antenna *if in the way*.
6. Disconnect speaker cable, antenna and ground leads, phonograph cables, etc., *when necessary*.
7. Remove chassis bolts and take out chassis.

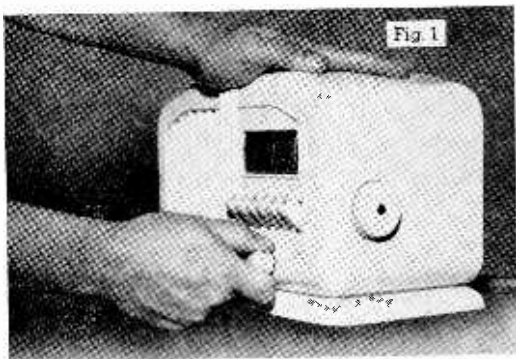

Now, we'll see how these steps apply to specific models. Remember that the *methods* I discuss will apply to *any similar case*, whether the cabinet is a midget, table, or console type. Thus, I may describe the removal of a certain type of knob under "midget sets," but this would apply to similar knobs on any set. Also remember that I am describing only representative types—I could not possibly cover them all.

#### Removing A Midget Chassis

Fig. 1 shows a midget receiver in a plastic cabinet. This universal a.c.-d.c. set has a manual tuning knob or wheel on the right-hand side. The knob on the front is the volume control and ON-OFF switch. Push buttons for automatic tuning are above this knob.

The first step in removing the chassis is to take off the knobs. This will allow the shafts to slip out of their cabinet holes when the chassis is removed.

There are three methods of fastening control knobs to shafts. There may be a set screw in the side of the knob which, when tightened, bites into the shaft; the knob may be held on simply by friction; or, as is the case with the tuning knob in Fig. 1, a screw may pass through the knob and into the end of the shaft.

To remove a knob held by a screw, simply loosen or remove the screw, and pull off the knob. If

no screw is used, then the knob is held on by friction. **TO REMOVE ANY FRICTION TYPE OF KNOB, JUST GRASP IT FIRMLY AND PULL IT OFF.** Hold the cabinet with the other hand, as illustrated in Fig. 1.

Now remove the main turning knob which projects from the side of the cabinet in the set shown in Fig. 1. A screwdriver is the only tool required. On many sets of this kind, releasing this knob also releases the locking mechanism for the push buttons. The push buttons will then probably get out of adjustment and will have to be reset.

As you take each part off the cabinet, put it in a small box so that it will not be lost, and you won't have to waste time looking for it when you reassemble the receiver.

Next, remove the back cover, if one is used. In most cases four screws will hold the back in place on the cabinet. If a wooden cabinet and wooden back are used, a number of wood screws may pass through the back into the edges of the cabinet. However, in my example, snap fasteners are used instead of screws. They pass through holes in the back and snap into the holes provided in the cabinet. Fig. 2 shows how you can pry out these snap fasteners with a screwdriver blade.

After the back cover is loose, tilt it back to see if a loop is mounted on it. If one is, it will be

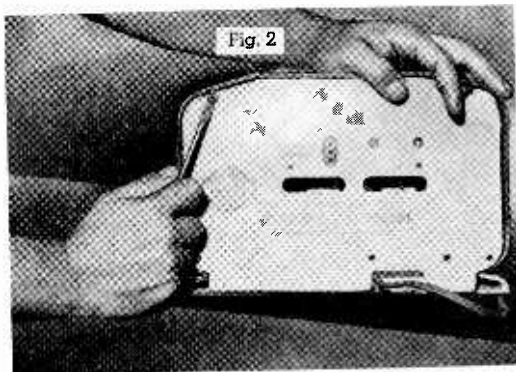

wired to the chassis, and you must be careful not to break the connecting leads. Sometimes you can leave the loop attached to the chassis, sometimes you'll have to disconnect it—but you should never rip it loose.

Examine the back of the chassis to see how it is held in the cabinet. In my example, the mounting bolts pass through the bottom of the cabinet into the chassis (see Fig. 3.) Here, the cabinet has been turned on its back so that the mounting bolts can be removed with a screwdriver. (Some-

times hex-head bolts are used; remove this type with a socket wrench.) Take out the lower bolts first, allowing the chassis to hang from the upper ones. If you take out the upper bolts first, the chassis will tend to twist in the cabinet and may jam.

Notice on the bottom of the cabinet, the chart giving the positions of the tubes and the make and model number of the receiver. In some cases, you will find a complete wiring diagram on the bottom of the cabinet.

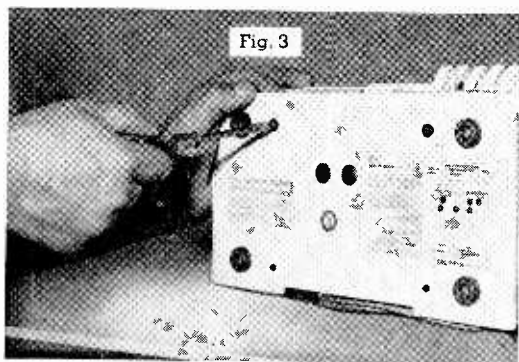

Fig. 3

As you take out the last mounting bolt, put your hand under the back of the cabinet. Hold the chassis up to prevent it from dropping out of the cabinet. Next, place the cabinet right side up with the back toward you. Hold the cabinet with one hand while you pull the chassis out with the other. Pull on a coil can or some other rigidly mounted part that won't be crushed or damaged.

Fig. 4 shows the chassis out of the cabinet and ready to be serviced. The numbers stamped on the front chassis wall are inspection numbers which do not identify the chassis. The model number of this receiver is on the label on the bottom of the cabinet.

The set shown in Fig. 4 has the speaker mounted right on the chassis, so it does not remain in the cabinet. This is generally true in midgets; however, in large receivers, the chassis and the speaker are mechanically separate and are connected electrically with a cable.

In Fig. 4 the hardware (knobs, snap fasteners, and screws) have been grouped together on the workbench so that you can see them. Remember that, on an actual job, you'd put each part in a container as you took it off.

The push buttons on the set pictured did not have to be removed, but in some receivers, like the one shown in Fig. 5A, it is necessary to remove the push buttons before the chassis can be taken from the cabinet. The push buttons shown in

Fig. 4 could be pulled off if necessary, but those in Fig. 5A have to be unscrewed in order to remove them, as shown in Fig. 5B. In each case a preliminary examination will show you what must be done, and how to do it.

The midget shown in Fig. 5B is somewhat different from the one in Figs. 1 to 4. Instead of screws through the bottom of the cabinet, the chassis is held in place by the bolt marked *C* in Fig. 5B and by another one on the opposite end of the chassis. Also, it does not have a back cover, but it does have a loop. This loop can be removed to make it possible to remove tubes for testing without pulling out the chassis. The loop is held on by two screws. If the chassis is to be taken out for servicing, the loop can remain in place. In still another type of midget, the tuning dial pointer slips over a shaft that protrudes through the front of the cabinet. The pointer is held in place by friction and must be pulled off before you take the chassis out of the cabinet. You will find many variations like this—be sure to watch for them.

#### Removing A Table-Model Chassis

Table-model receivers are larger than midgets, but are in cabinets designed to be placed on tables or shelves. Remove the control knobs first. If you find a set screw holding a knob, rotate the knob to make sure there aren't two screws—some *early receivers* used them.

Next, turn the cabinet on its side and *loosen* the four mounting bolts as shown in Fig. 6. Don't

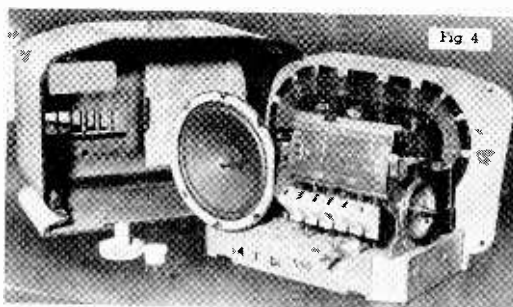

Fig. 4

take them out completely—if you do, the heavy chassis may fall over inside the cabinet, and some parts may be damaged.

After the mounting bolts are loosened, set the cabinet upright on the workbench with one edge of the cabinet sticking out over the edge of the bench, as shown in Fig. 7. Remove the mounting bolt thus exposed, then repeat the process to remove the other mounting bolts.

Next, grasp the power transformer (or some other large, firmly mounted part), and pull the

chassis out of the cabinet (Fig. 8). If you look closely at this figure, you can see the cable that connects the loudspeaker and the chassis. If the cable is long enough, you may not have to remove the speaker from the cabinet. *If you wish, you can unplug the speaker cable, but be sure you NEVER turn on the set with its speaker disconnected.* On this set, the connecting plug is mounted on the speaker; sometimes you will find it on the back, the side, or the top of the chassis. Some sets have no plug in the speaker cable.

When the cable is not long enough to let you take the chassis out of the cabinet and work on it readily, the loudspeaker must be removed. To remove the loudspeaker, loosen the nuts around the back of the speaker rim with a socket wrench. Hold the speaker in place with your hand while taking off the last nut. Then, grasping the magnet frame, pull it straight back, and place it face down on the workbench on a clean piece of paper.

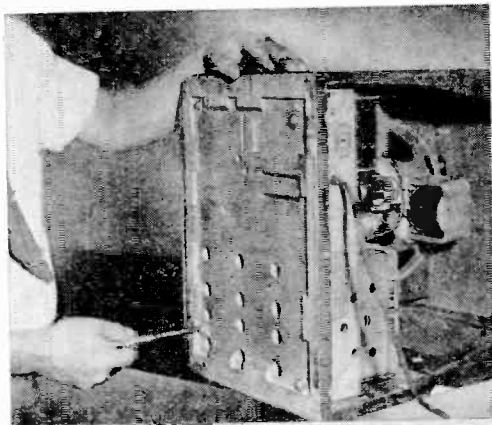

Fig 6



Fig 7

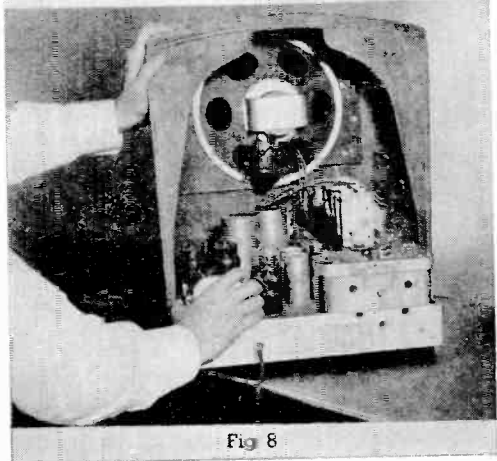

Fig 8

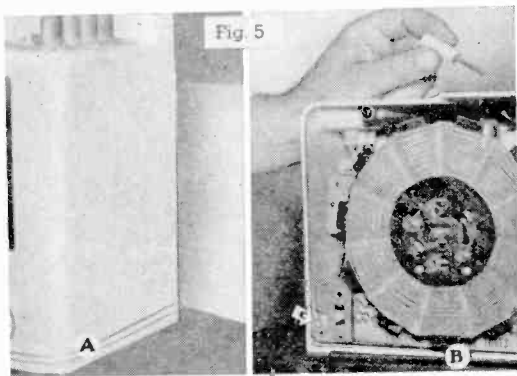

Fig 5

Be careful not to puncture the speaker cone by putting it on some sharp object.

When you reinstall the speaker, be very careful to line up the holes in the speaker rim with the proper mounting bolts. Carelessness in reinstalling the speaker will allow the mounting bolts to punch holes in the speaker cone. If the cable is short, turn the speaker so that the cable will be long enough to reach from set to speaker when both are reinstalled. If the output transformer is mounted on the speaker, be sure it is placed so that it will clear all chassis parts when the chassis is slipped in place.

#### Removing A Console Chassis

Fig. 9 shows part of the front of a console receiver. All knobs must be removed. These knobs are usually of the friction type. In this particular case, the knob is stuck and will not come off easily, so a serviceman has folded a handkerchief and slipped it under the knob. By pulling on the ends of the handkerchief, he can remove

the knob without trouble. This is a good trick to remember—you'll find it handy time and time again.

On this model, the dial pointer must be removed.

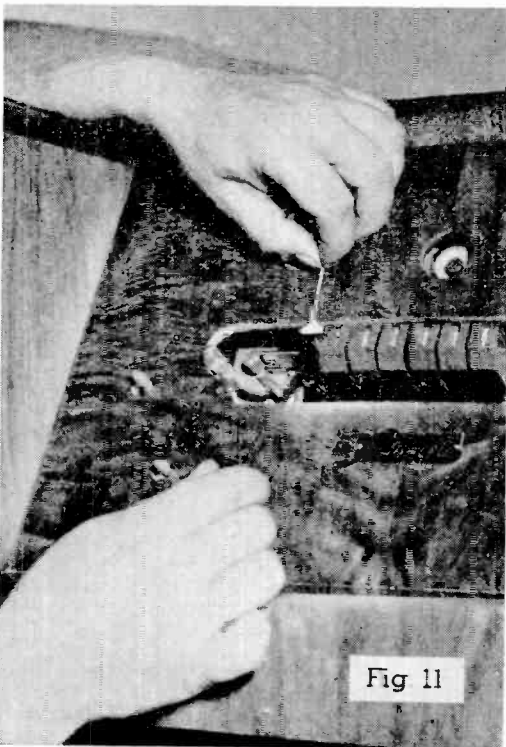
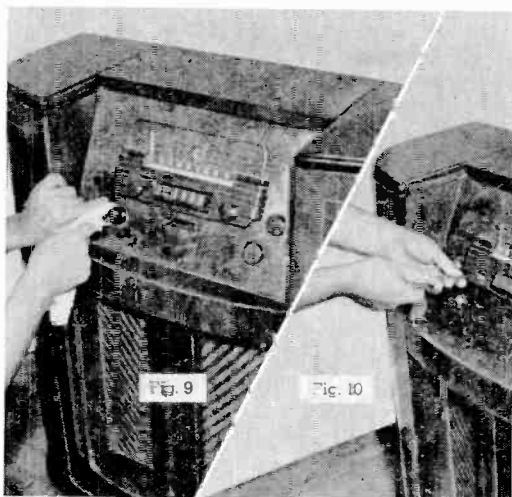

Its operating mechanism protrudes through a slot cut in the cabinet. Fig. 10 shows how the dial scale is removed so that the dial pointer may be disconnected from the chassis tuning mechanism. The scale is held in place by four wood screws. (Watch for Phillips screws here; these require the use of a small Phillips screw-driver.) When these screws have been removed, slip off the dial scale, and, as shown in Fig. 11, remove the dial pointer by loosening the screw that holds it at its bottom. The dial pointer will be bent or broken if you pull out the chassis without removing the pointer first.

Fig. 12 shows a back view of the chassis. The speaker is in a compartment below the chassis. So is the loop antenna, which is inside the cardboard form that surrounds the speaker. Cable leads pass from the speaker and the loop through

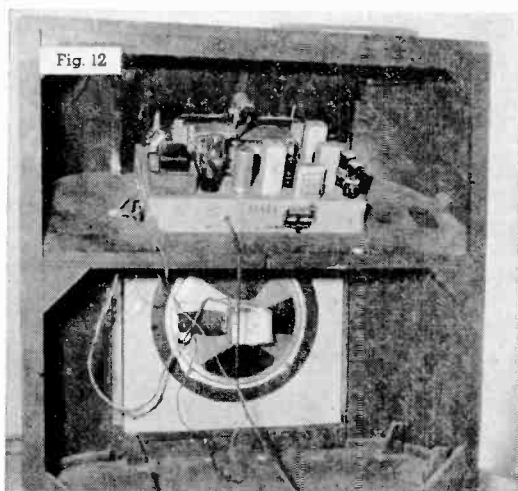

holes in the chassis mounting-board and plug into jacks on the left-hand side of the chassis. *Never cut a cable that passes through a hole in the cabinet.* You will always find a plug at one end of the cable. Disconnect such plugs, making careful note of where each goes.

Now take out the bolts holding the chassis to the wooden shelf. You'll probably have to lie on the floor so that you can see the bolts and get a large screwdriver into them, as shown in Fig. 13. Before the last bolt is completely removed, put your hand on the back of the chassis so that it can't slide down the inclined shelf and fall on you or the floor. Fig. 14 shows the chassis being slid out of the cabinet.

In a few receivers, you will find that the dial is mounted on the chassis and also is screwed to the front of the cabinet to give it greater rigidity. If, when you start to pull the chassis

out of the cabinet, you find that it is being held, don't just pull harder. Stop and see what's holding it. If the dial is screwed to the cabinet, remove the screws.

Notice the tools and parts left on top of the cabinet in Fig. 14. This is something that should never be done, for the top of the cabinet may be scratched, and no housewife is going to like the idea even if the cabinet isn't damaged. It is best to replace all tools in the toolbox as soon as you are finished with them, and to place knobs and screws in a container (a small jar, can, or box carried in your tool kit).

Installing a chassis of this kind is much easier than taking it out, because generally you don't have to lie down on the floor. You can tell from the old dust marks or press marks just how the chassis was placed originally in the cabinet, and when you have it exactly in place, you can easily start the chassis mounting bolts with your hand and finish up with a screwdriver. By feeling with your fingers, you can slip the screwdriver blade into the screw head slot without much trouble.

In some receivers, the control knobs stick up through the top of the cabinet. In this instance, the chassis may be mounted on a baseboard, as

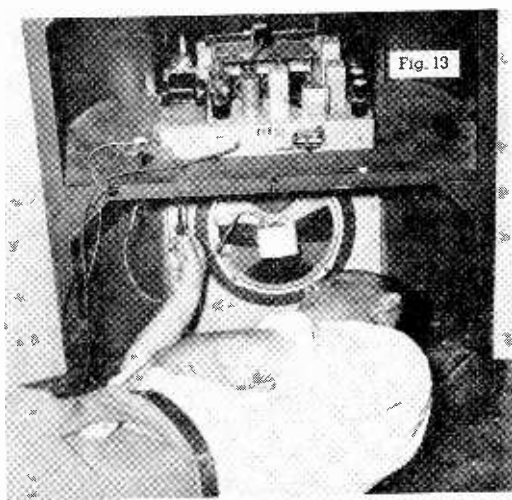

shown in Fig. 15. This baseboard will be screwed to the front of the cabinet. Loosen the screws A-B-C-D-E-F one at a time, taking out first those that are hardest to reach. These are usually the ones in the top. Hold the chassis with one hand or put books or blocks under it to hold it in place while you take out the last screws. Lift the chassis out of the cabinet. You can then lay the chassis on its back or on its side and take out the

bolts that fasten the mounting board to the bottom of the chassis.

Fig. 16 shows a side view of the chassis designed for many uses. It can be used as a small public address system by plugging a microphone into the jack provided for this purpose, or it can be used to amplify the output of an electrically-operated phonograph. Note the number of jacks and sockets for the various attachments. You will not always find a label pasted on the chassis indicating the use of each jack. It's a good idea to look first, and, if there is no label, to mark with a pencil on the side of the chassis the position occupied by each plug you remove. Then you



will have no trouble in getting the right plug back in the right jack.

Of course, if you can look at the side of the chassis when you are ready to put back the plugs, you won't have much trouble, since the plug pins generally are arranged in such a way that they will fit only into the proper jacks. If you can't see the jacks, however, you may do considerable fumbling around before you get the right plugs into the right jacks, so a sketch of some sort will save you time.

In a few receivers, you will find that the leads from the phonograph motor are soldered inside the receiver chassis instead of being plugged into a socket (look for a plug at the motor). When there is no plug, these leads must be cut before you can take the chassis out of the cabinet. Be sure that the receiver is disconnected from the power line before you try to cut these leads with your side cutters. It's best to stagger the cuts on the two wires, as shown in Fig. 17A, instead of cutting them both at the same place.



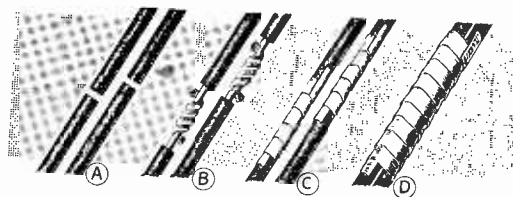
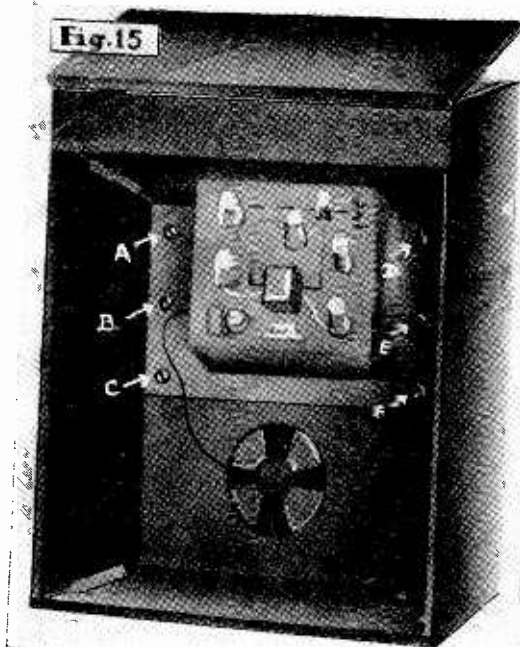

Fig. 17

you have completed a service job—one of which you can well be proud.

— n r i —

## Our Cover

### Motorola "Handie Talkie" Aids In Hunt For Escaped Prisoners

The "Handie Talkie," originated and developed by the Galvin Mfg. Corporation, makers of Motorola Radios, proved an invaluable instrument in fighting a fast-moving, fluid war. The "Handie Talkie," a tiny two-way radio small enough to be carried in a man's hand, was the communications link for our front-line fighting forces all over the world.

The value of the "Handie Talkie" in peacetime is graphically illustrated in the photograph on our cover. Here, the "Handie Talkie" is being used to tighten the net around a group of convicts who escaped from the Prison Farm at Bordentown, New Jersey. The convicts stole a guard's car after slugging him, and travelled until a blowout forced them to abandon the vehicle. George Ireland (center) who saw the escaped convicts leave the car and head for the woods, is relaying the information to Lt. John C. Doyle (right) of the Trenton, New Jersey Police. Trooper A. W. Geran (left) is sending the report to the entire posse via his "Handie Talkie." In this manner all members of the searching party are kept up to date on the latest developments.

— n r i —

"The February-March issue of your NATIONAL RADIO NEWS was a great help to me; particularly, the articles by Mr. Straghan, Mr. Moody and Mr. Conner, which were written so that the student, not merely the graduate, could understand. It was a pleasure to read Mr. Moody's article and not get "lost" once, and at the same time learn so much about the "Fundamentals of Filament Circuits." I hope that you will keep up the good work and give the student some more articles like these."

H. W. Bomser  
1080 Ocean View Avenue  
Brighton Beach, Brooklyn, N. Y.

Page Nine

When you reassemble the receiver, strip the insulation off these four wires, reconnect them with twist connections (Fig. 17B), solder the joints, and cover the joints with tape (Figs. 17C and 17D).

After you have made your repairs and the chassis is now ready for replacing into the cabinet, reverse the steps I covered in the removal of the chassis. After doing so, polish the outside of the cabinet carefully, with a good grade of furniture polish, and the receiver can now be returned to its owner. Connect it to its antenna and ground, plug in the power cord, and

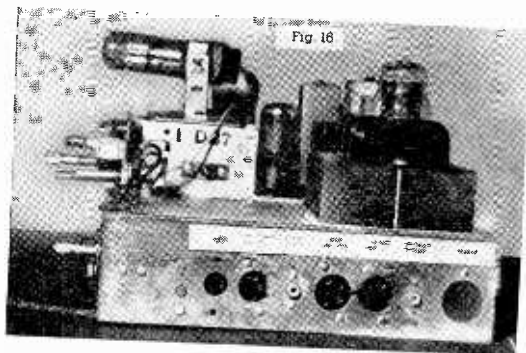

# Kinks and Short Cuts

By Don Looney.

"So *that's* the way you get around that job which caused me no end of worrying!"

Sam Hathaway greeted me with this ejaculation which expressed a satisfied feeling that he had learned something new after I had remounted a repaired I. F. transformer can, in what appeared to him, a surprisingly short period of time.

Several times previously I have been greeted in the laboratory with the above or similar statement when all that I did was to apply some simple "knack" which to me seemed so obvious that I thought everyone should have done likewise or better.

"Well, it is simple, isn't it?" I countered when he made his opening remark. "You would have figured it out for yourself soon enough, I am sure. Why, everyone does that unconsciously when needed."

"Yes, it is simple," was Sam's answer. "But I didn't think of it and Bill Gregory didn't do any better than I because he tried the same as I did. Why don't you describe it in the NATIONAL RADIO NEWS?"

Sam Hathaway's last remark was the beginning of this article. I'll describe some of the "kinks" which I have used at various times in radio servicing and in the laboratory with the hope that others may profit and perhaps tell us of some of their own methods for doing these or similar jobs in a better way.

The particular "kink" which started this article was in regard to replacing the mounting screws in the two holes in the base rim of an intermediate frequency transformer which fastened to the chassis, down among a maze of closely fitting parts and wires. The problem was to quickly get the screws with their lockwashers into the threaded holes in the chassis, without these screws repeatedly rolling away, thus avoiding much loss of time and also avoiding a bad case of "Nerves."

First, I simply held the I. F. can in my left hand, out in the open. Then I placed a lockwasher over one hole in the rim of the I. F. can. Next, I inserted the screw through the lockwasher and into the hole in the rim. I did likewise with the other lockwasher and screw. Figure 1 illustrates the arrangement of these parts. Then I carefully guided the can downward among the maze of parts until one tip of one screw barely touched the chassis right over the threaded hole but I was

careful to hold the can at a very slight angle so the other screw would not touch the chassis and be pushed out of its hole and roll away while working with the first screw. Now I picked up the screwdriver and gave the first screw one or two turns, just enough to get it started into its threaded hole in the chassis. I next did likewise with the second screw while still holding the can far enough above the chassis until the point of the screw was started properly in its threaded hole. Then I could release the hold I retained on the can with my left hand and the rest of the job of tightening the screws was easy.

Sam commented that he had tried the job "the hard way" by first putting the I. F. can in place and then "trying" to wiggle the point of the screw into the lockwasher and threaded hole with the help of pliers and a screwdriver, while gravity did everything to the head of the screw to keep the head from being raised higher than the point. Then I told Sam that if he wanted or had to first put the rim of the can down on the chassis, he could use another "kink" which I have often used successfully. I'll describe it now.

Put the part down where it belongs. Then take a piece of bare No. 24 wire about a foot in length.

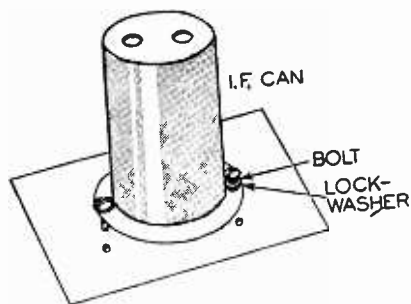

Fig. 1

Bend a loop at one end of it. Insert the screw loosely, with its lockwasher attached, into this loop. Refer to Figure 2. Then bend an angle in the wire near the head of the screw so the remaining length of wire will serve as a handle for lowering the screw, with its head up and its point down, and guiding it downward among the maze of wires and parts. You can now guide the point readily toward its threaded hole and then apply the screwdriver. As soon as the threads have caught, pull out the wire.

# in Radio Servicing

NRI Consultant

The use of the wire for a guide reminds me of another simple "kink" for placing and starting nuts on the threads of a screw which has its point facing upward or sideways but located also among a maze of wires so the nut cannot be started with your fingers. Refer to Figure 3. In this case hold a straight piece of bare wire with the fingers of your right hand, then slip the point of this wire through the nut and then through the lockwasher which are held together with the fingers of your left hand. With your right hand guide the point of the wire downward against the point of the screw. Let the lockwasher and nut drop out of your left hand fingers. These parts will now fall into position against the point of the screw. Transfer the upper end of the wire to your left hand. With the aid of the blade of a screwdriver "kick" the nut on the threads. A few spins of the nut will soon cause its threads to catch on the threads of the screw. The wire then can be removed and the job finished with the aid of a socket-type wrench or a pair of pliers.

On other occasions for starting screws and small nuts in seemingly inaccessible places I have used stick substances, such as pitch or quick-drying "rubber cement" applied to the blade of a screwdriver or to the inside of a socket wrench.

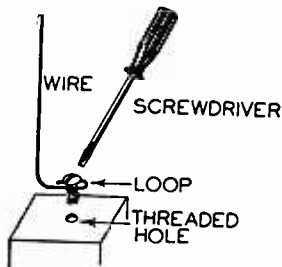

Fig. 2

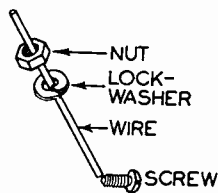

Fig. 3

Automobile tire-cement, or the cement for patching and gluing the diaphragms of loudspeakers serve nicely for this purpose. Dip the blade of the screwdriver lightly into the cement, expose this coating of cement to the air for a short while until the solvent evaporates, or speed up the drying process by blowing your breath on the coating. Then stick the screw or nut to the prepared driver and guide it into position.

The above "kink" was the indirect result of a suggestion made to me many years ago for making home-made screwdrivers for starting screws,

long before I used or even heard of commercial types of "hold-fast" screwdrivers. The man who made the suggestion told me to fashion screwdriver blades on the eraser ends of pencils with the aid of a razor blade. The "rubber blade" purposely was made a trifle wider than the slot in the head of a screw. This allowed the "blade" to be forced into the slot and grip its sides. The idea was effective until the rubber blade became smooth and worn. On one occasion a tube of rubber cement was handy and I processed the smooth rubber blade. Then I extended the idea to processing metal blades and the inside of socket wrenches. I mention this original idea in event that you find rubber cement or commercial type hold-fast screwdrivers are not handy.

Incidentally, when socket wrenches are missing, you will find that rubber cement applied to the eraser end of a pencil is very effective for starting the larger nuts. This is due to the extra friction obtained between the rubber eraser and the face of the nut. Of course, in this case the job is finished with the aid of pliers.

While speaking about screws I am reminded of the wooden cabinets and loudspeaker frames which are held together with wood screws. Frequently you might attempt to drive these screws into new or tight fitting holes in hard wood where much effort is needed or where the screws are damaged unless soap is applied to the threads of the screws. Simply moisten the bar of soap with water, rub the threads across the soap and use the prepared screw. You will wonder probably if this screw fits tight enough because so little effort is needed now to turn it. However, the same holding power is present while you have simply made your work easier with the aid of lubrication with soap.

Soap applied to the runways of windows, desk or shop drawers, or other sliding objects such as slide rule guides will overcome friction. Soap applied to a nail, when driven into hard wood with a hammer, also will make a seemingly impossible or tedious job an easy one.

Yes, a serviceman does occasionally use nails and a hammer, when fitting up or improving his shop. He may find that the head of the hammer slips off of the head of the nail or tends to bend the nail when hammering. Nine times out of ten it is due to the head of the hammer being too smooth—rub the striking face of the head of the hammer a few times on a concrete or brick surface. Yes, it's simple but it works.

While fitting or cleaning up the shop, I wonder how many servicemen dust their analyzers and

occasionally find that their meter needles temporarily have gone haywire and apparently cannot be reset to zero, making them wonder if the meter was accidentally burned out, or accumulated foreign matter during the cleaning process. If it happens to you, relieve your dire thoughts and suspect that the friction of rubbing the cleaning cloth over the glass face has temporarily placed a static charge of electricity on the glass which pulls the needle away from its normal zero setting. Simply open your mouth wide and gently blow a breath of warm moist air against the glass to dispel the static charge held on the cool dry surface of the glass. Many meters of recent design use special glass which cannot accumulate such a charge.

But perhaps your meter has actually accumulated dust inside the case of the meter which makes the needle stick or move with an erratic motion. You are confident that you can do a ticklish job of cleaning. Yes, you carefully take the cover from the meter and then realize how delicately adjusted is the needle—you want to try moving the needle with your ever increasingly clumsy fingers. Your reason tells you correctly that it is better to refrain from touching the needle. Here you can again make good use of your breath, this time opening your lips only slightly to emit a steady but well directed shaft of moving cool air against the needle. The needle will respond readily unless obstructed and there is no danger of bending or breaking the delicate parts, even when an obstruction is there.

During this time of inspecting the meter you may find that one of the delicately soldered joints needs resoldering. Again you realize that the regular service soldering iron is entirely inadequate for this job because the tip is much too large. In this case make a coil of four or five turns of bare No. 12 copper wire which fits snugly around the copper tip of the regular soldering iron. Then bend this piece of copper wire at right angles near the point of the regular copper tip in order to make a new but smaller tip which extends about half of an inch beyond the regular tip. This is shown in Figure 4. File this new tip slightly flat so it will retain solder readily. Then heat the iron, carefully tinning the new tip and also applying solder along that portion of it which comes closely in contact with the original.

When working with this smaller tip you can solder the smallest wires which you will ever encounter in the repair of radio receivers and testing instruments. However, it is well to realize that the smallness of the tip and the distance with which it is located from the source of heat will tend to keep it much cooler than the point of the original tip, unless you carefully see to it that heat is properly conducted toward this small tip.

Heat has a tendency to rise. Therefore, keep the

tip up by lowering the handle of the iron when more heat is needed.

This brings up several other servicing "kinks" while using the regular service soldering iron.

How often have I seen servicemen holding a soldering iron with its tip hanging downward while waiting patiently and often impatiently for it to reach the proper soldering temperature, then cussing because the *handle* gets hot while the *tip* fails to reach the desired degree of heat. Eventually the tip gets *almost* hot enough then they start their job, still holding the tip downward. Naturally, their job is slow and tedious. Often the job is unsatisfactory all because they are not aware that heat rises.

Of course, the remedy again is simple. *Keep the tip raised to obtain maximum heat in the quickest time at the tip.*

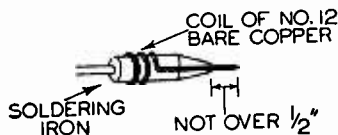

Fig. 4

Also learn to rely on the *changes of color* in heated metals to tell you when you are ready to *begin and stop* soldering. These colors serve as thermometers to the experienced serviceman. They conserve their time and efforts.

For example, you can tell from the changing colors of copper when the tip of a soldering iron is too cold, or too hot, and also when it has reached the proper degree of heat by viewing a cleaned copper surface of the tip at a point which is not tinned. Stroke a single sweep of a file lightly over the copper tip. If this cleaned surface remains at a bright *copper color*, the tip is *too cold*. But if this cleaned surface immediately changes color and turns from bright copper to *purple* you can be assured that the *proper* temperature has been reached.

If the copper tip turns *cherry red* or "*red hot*" then the tip is *too hot*. A tip which is *too hot* is just as bad as *too cold* because you can't make solder stick properly. It just can't be done, so don't waste time trying.

It is well to test your iron in this manner before attempting to solder any kind of joint, from the simplest joint to a heavy or bulky connection, where the right amount of heat is needed always to do a job quickly and thoroughly.

Relying on the color of metals to determine their degree of heat also is useful for letting a serviceman know just when solder has melted and also

(Page 24, please)

# Radioautobiography of H. B. Matthews

*The following story originally appeared in the magazine, Radio Maintenance, and is reproduced here through the kind permission of the Editor of that publication. It is of interest to us because it refers to an NRI graduate.*

**B**RIEF, but to the point, is this story from H. B. Matthews, of Houston, Texas. His story is like that of many who have entered radio from other fields, and found it to their liking. Matthews says:

"I was a stationary engineer, but during the worst of the depression I was no longer a stationary engineer—I was out of work and could get none. Worse than that, I was really down and out, unable to pay my rent or buy groceries. One Sunday, I saw the advertisement of a rather well known radio institute. That determined me. I took their course, receiving my diploma in two years; then I started my radio work, six years ago.

"Just out of the hospital, flat broke, with no money and no stock, I started in radio . . .

Now I have this shop, and a man working for me. I have about \$3,000 in stock and I have bought three houses and six lots which are about three-fourths paid for, with sufficient rent from them to pay out the balance if the radio work can not do it. But it does not look as though they will have to pay for themselves—radio work keeps on and on. I can do the work, I feel fine and weigh about 200 pounds, and I try to please the people.

"In achieving what success I have in the radio servicing business, I have tried to put the people first, then equipment and parts, and then my own interests. I have found that if you know your business and give good service you will be busy all the time."

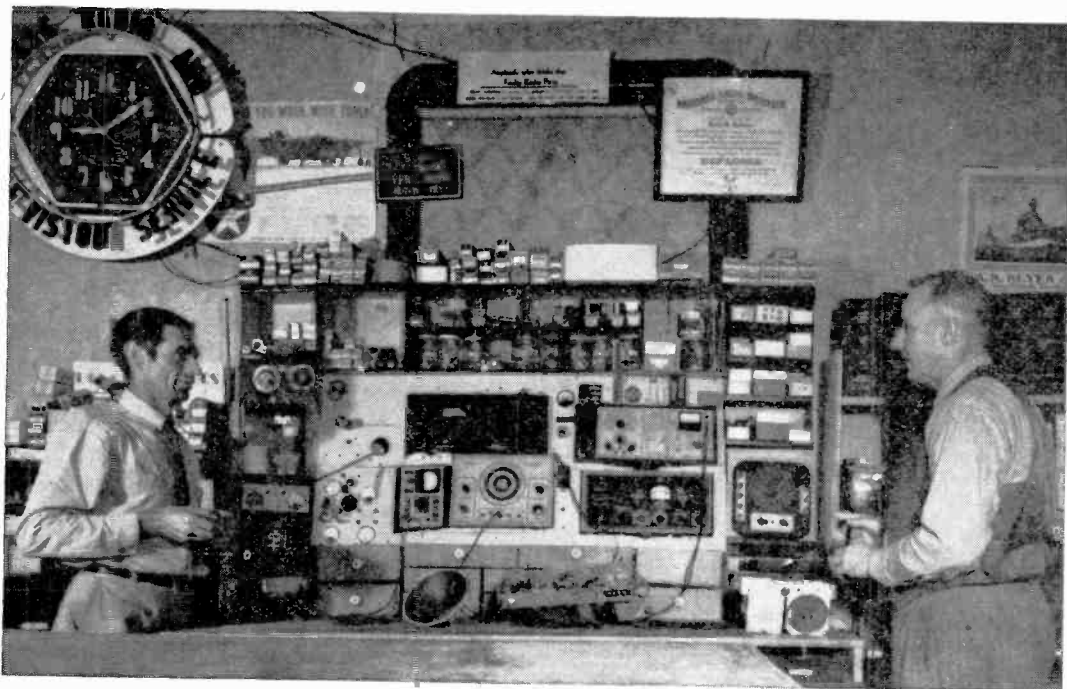

# Basic Principles in Resistance Measurements

By Willard Moody  
NRI Consultant



Willard Moody

**A**N electric current flows when we have a source of voltage and continuity in a circuit. In Fig. 1, a simple circuit is illustrated. The flashlight bulb lights when the circuit connection is made and the current from the battery passes through the lamp filament.

*If we open the circuit, no current flows and the bulb does not light up.*



Fig. 1

by connecting headphones to a battery system as shown in Fig. 3.

When the test prods are touched to a low resistance circuit a loud click will be heard. If the circuit resistance is much higher in value, the click will be correspondingly weaker. Accordingly, the intensity of the click permits us to judge, very roughly, if the circuit resistance is

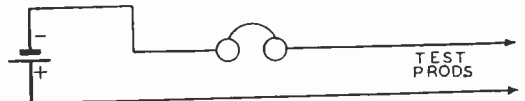

Fig. 3

The fact that we have continuity is indicated by the bulb lighting up. If, now, we wish to test an external circuit for continuity we may use the arrangement shown in Fig. 2. Naturally, the sensitivity of a circuit of this kind is quite limited. If we connect an extremely high value of resistance across the test prods, not enough current will flow to light the bulb.

We can use a more sensitive circuit, if we wish,

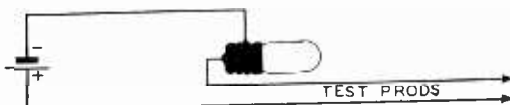

Fig. 2

high or low. We have no definite means of determining the resistance value, however, and we may find it desirable in modern work to use a meter with a calibrated ohm's scale.

An alternative method of checking the circuit resistance ( $R_x$ ) would be to use a current meter with an accurately calibrated scale and a known source of voltage. Then, by Ohm's law, with which we are familiar, the value of resistance

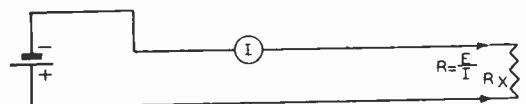

Fig. 4

would be simply the voltage divided by the current reading of the meter. This is illustrated in Fig. 4. But suppose the value of resistance was extremely low. Then, there would be no protective resistance in the circuit to limit the amount of current that would flow in the meter. Because of this, the meter might be burned out. To avoid burning out the instrument we may use a protective series resistance ( $R$ ) in the circuit. This arrangement is shown in Fig. 5. Now, our current meter becomes in effect a simple voltmeter.

If the meter is an 0-1 milliamper type the full scale current will be .001 ampere. Then, assum-

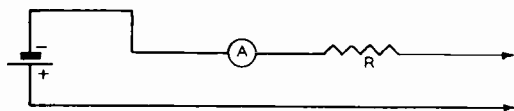

Fig. 5

ing that the meter circuit resistance is negligible, the amount of resistance required in the circuit would be 1.5 divided by .001 or 1500 ohms.

When the test prods, now, are shorted together, a full scale deflection is obtained on the meter, showing zero resistance.

Now the test probes shown in Fig. 5 may be connected across a circuit to check its resistance.

If the circuit resistance being checked is 1500 ohms, one-half of the voltage drop in the circuit will develop across the internal resistance and the meter will read half-scale.

This permits us to judge, approximately, what the circuit resistance is when we make a test.

If we wish, now, we may calibrate the meter by

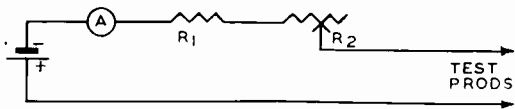

Fig. 6

taking a number of known resistance values, writing down those values and, opposite them, the meter deflections obtained. An ohmmeter of this kind is simple and easy to use. However, it has some disadvantages. If the cell voltage drops, no longer shall we obtain a convenient full scale deflection. The amount of resistance

in the circuit of Fig. 5 is fixed. We can overcome this disadvantage by using an adjustable circuit resistance as shown in Fig. 6. Here,  $R_2$  is a fixed resistor and is adjustable. Therefore, even though the cell potential does drop we will still be able to use the circuit efficiently. The meter does not burn out when  $R_2$  is set at zero resistance value because protective resistance  $R_1$  is still in the circuit.

Practical factory made ohmmeters which servicemen use may be relatively complicated in circuit design and construction, in comparison with this simple circuit. It would not be practical to build the circuit in Fig. 6 as it would not check all resistance values found in receivers. It is shown here to aid you in understanding how continuity tests are made.

Now, let's see just how we could use an ohmmeter for making practical servicing tests.

*Checking an r.f. coil.* In Fig. 7, a typical r.f. coil which could be an antenna transformer, is shown. This transformer has a primary and a secondary. You may check the primary and secondary for continuity by applying the ohmmeter to terminals 1 and 2, and to terminals 3 and 4. In both tests, an indication on the meter



Fig. 7

should be obtained, showing that the coil is intact and not burned out.

In some a.c.-d.c. receivers, the primary of the antenna transformer is isolated from the antenna by means of a series blocking condenser. In sets of that type, the circuit arrangement may be similar to that of Fig. 8. The series condenser, C, may be mounted directly on the antenna transformer. In testing the primary and secondary we would not measure the resistance between terminal 4 and any of the other terminals but we would check it between 1 and 2, and 3 and 2. Note that there is a common connection to point 2 in the circuit.

#### I.F. Transformers

A typical i.f. transformer circuit is shown in Fig. 9. In order to check the primary, we test for resistance between terminals 1 and 2; for the secondary between 3 and 4.

Note, however, in this circuit that we have trimmer condensers across the coils. To isolate a condenser from the circuit, for test purposes, we may disconnect one lead to the condenser. Then, the condenser itself may be checked for a short circuit. If we had a short circuit or excessive leakage in a condenser, normal tuned circuit action would not be obtained.

### Audio Transformers

In Fig. 10 a typical iron-core audio transformer is shown. Here, again, to check continuity of

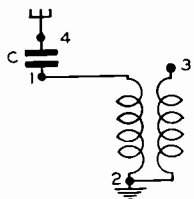

Fig. 8

the windings we may apply the ohmmeter to terminals 1 and 2, and 3 and 4. We should get an indication between the pairs of terminals. However, we should get no indication or only an indication of extremely high resistance between terminals 1 and 3, or 2 and 4.

If terminals 1-2 connect to the primary, the resistance between 1 and 2 may be much lower than that between 3 and 4. The secondary of the transformer, assuming the transformer is one having a step-up turns ratio, will have a higher resistance.

An exception to this would be the step down output transformer of a receiver. In the output transformer, the primary circuit resistance may range from 100 ohms to as high as 500 or 600

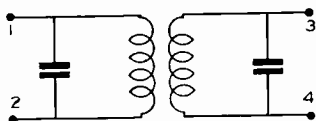

Fig. 9

ohms. This would be the resistance between terminals 1 and 2. The resistance across terminals 3 and 4, of such a transformer, might be extremely low, well below 1 ohm.

The fact that the resistances are different permits distinguishing the windings and identifying them.

In many modern radio receivers, small, simple carbon resistors are used. Resistors of this type

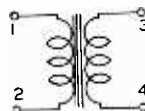

Fig. 10

may readily be checked with an ohmmeter. A typical set-up is shown in Fig. 11. The resistor is tested by applying the ohmmeter directly to the resistor pig tail leads. Wire-wound resistors are also checked by applying the ohmmeter directly to the resistor terminals. The resistance values, commonly, are given in schematic circuit diagrams of radio receivers and it would be worthwhile for you to refer to the diagram of the receiver while making such tests.

**Paper Condenser.** In Fig. 12 the application of the ohmmeter to a paper condenser is shown. Condensers normally should pass signal currents or a.c. currents but not d.c. currents. The amount of current passed by the paper condensers should be very small. This means that the leakage re-

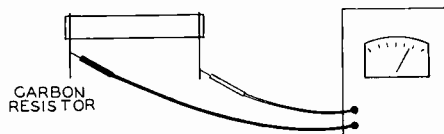

Fig. 11

sistance is particularly important and the grid condensers should have very high leakage resistances, higher than 20 megohms. In plate return and screen return circuits, the leakage resistances are less critical and values above 5 or 10 megohms are permissible.

### Electrolytic Condensers

A paper condenser does not have polarity. An electrolytic condenser must be connected properly with respect to polarity. In testing an electrolytic with an ohmmeter, take two measurements. After the first measurement reverse your test leads. The highest resistance measurement is the correct one. Once you learn which ohm-



meter probe must be connected to the positive condenser terminal to give the highest resistance reading only this one test will be necessary. The test probe going to the positive battery terminal inside the ohmmeter is the one which should connect to the positive condenser terminal. If the ohmmeter is part of a multi-meter the positive ohmmeter lead is in *most* instruments the black test lead. The test circuit is shown in Fig. 13.

Usually, if the condenser is in good condition the leakage will be higher than 100,000 ohms.

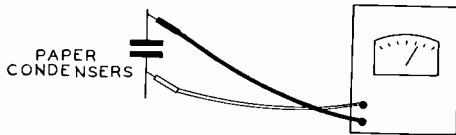

Fig. 12

It may be as high as 2 or 3 megohms, depending on the condition and design of the condenser.

By making a number of tests on condensers definitely known to be good, of various capacitance values and voltage ratings, you can secure a better understanding of what indications should be obtained on *your* ohmmeter.

#### Tube Filaments

The filament of a tube may be checked for continuity with any continuity indicator that does not cause an excessive amount of current to flow

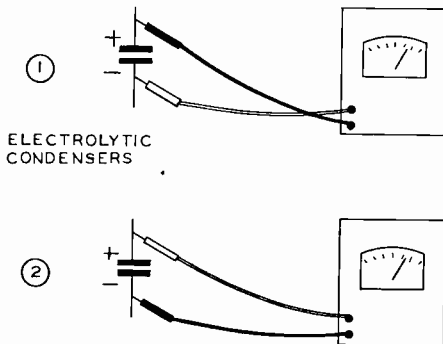

Fig. 13

through the filament. For example, a simple headphone test unit may be used for checking continuity. The flashlight bulb and battery sys-

tem would not be very suitable for checking filament circuit continuity because the test current might burn out the tube filament. An ohmmeter could be used efficiently.

Identify the filament prongs of a tube by referring to a tube chart. Some tube prongs are easily identified. For example, the type 80 has two large filament prongs which can easily be distinguished from the two small prongs on the tube base. The two large prongs are the filament prongs. The type 27 has a 5 prong base. The two prongs which are closest together are the filament prongs.

Tubes such as the 26, 71A, 45, etc., having 4 prong bases have filament prongs that are easily identified. As you practice making such measurements, you will become familiar with the filament connections of the most commonly encountered tubes and will have no difficulty whatever in applying the ohmmeter or continuity tester to the filament prongs.

#### Filter Choke

The filter choke is an iron-core inductance. The inductance has resistance and continuity. It may



Fig. 14

be tested, as shown in Fig. 14, by applying the ohmmeter or continuity indicator's test prods directly to the terminals or leads of the choke.

#### Pilot Light

The application of an ohmmeter to a pilot lamp is shown in Fig. 15. The screw portion of the bulb forms one electrode or terminal and the small insulated metal at the center of the base forms the other electrode. When the filament is intact and the lamp is in usable condition the ohmmeter shows continuity.

If the lamp has burned out, no indication of continuity is obtained.

Ordinary electric light bulbs may be checked in a similar way for continuity.

#### Volume Controls

In Fig. 16 a typical potentiometer volume control is shown. This control might have a resist-

ance of 8,000 to 100,000 ohms in an antenna-C bias circuit or 250,000 ohms to 2 megohm in an audio grid circuit or diode second detector circuit.

In checking the control we may measure the resistance between terminals 1 and 3. These are the two end terminals. Resistance values should be close to the values indicated by the manufacturer on the circuit diagram. Also, we should have a smooth variation in resistance as the control shaft is adjusted. We may check that variation by connecting an ohmmeter to terminals 1 and 2. When the arm of the control is set close to terminal 1 a zero resistance indication should be obtained. As we move the arm closer to



Fig. 15

terminal 3, the resistance between terminals 1 and 2 rises.

In other words, we progress from the zero resistance value to a much higher value as indicated above.

If we find that the ohmmeter needle kicks and jumps as the shaft of the control is adjusted, the control is probably the cause of the noise in the receiver and should be replaced. Then, we may try a new control in the radio and observe the effect on performance.

#### Checking Resistances in a Typical A.C.-D.C. Receiver

In Fig. 17, the Emerson BA-199 receiver is shown in schematic diagram form.

The filament circuit of the set may be checked for continuity with an ohmmeter. As an illustration, placing the ohmmeter across C11 would normally result in a resistance indication equal to the value of resistance used in the ballast tube. That is, the effective circuit resistance between terminals 3 and 7 would be indicated. The resistances of the tube filaments, when cold, are very low—practically zero.

If an indication was not obtained with ohmmeter connected across C11 but was obtained with the ohmmeter connected between terminal 7 of the ballast tube and the chassis, we would know that the filament of each tube is in good

condition but the resistance in the circuit between terminals 3 and 7 is not normal. That might be due to an open in the 3-8 or 7-8 sections of the ballast tube. Assuming the pilot lamp were not burned out, a resistance would be indicated between terminal 7 and 8 even though the shunt resistance section connected across the pilot lamp were burned out.

If a resistance indication is obtained when the ohmmeter is placed across the 6C6 filament terminals but is not obtained across the 6D6 filament terminals, it's likely the 6D6 tube is burned out and the 6C6 has a filament in working condition.

Other, simple tests will occur to you with reference to the filament circuit.

The grid circuit of the 6D6, 6C6 and 25L6 tubes may be checked with an ohmmeter. A simple method of connecting the ohmmeter to the 6D6 is to touch one test prod to the top cap of the tube and the other to the chassis. Then, the secondary of the antenna transformer, T1, is checked for continuity. An open grid circuit would prevent normal gain from being obtained in the r.f. stage. In a similar way, the 6C6 grid circuit may be checked. Touch the top cap of the tube and the chassis with the test prods. Touch one test prod to pin terminal No. 5 of the 25L6 socket and the other test prod to the chassis to check the value of R7 and grid circuit continuity in the output stage.

The cathode circuits, similarly, may be systematically tested. Put one ohmmeter test prod on the chassis and the other ohmmeter test prod

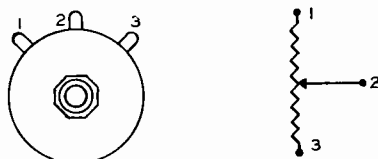

Fig. 16

on the 6C6, 6D6 and 25L6 cathodes to check respectively R<sub>2</sub>, R<sub>1</sub>, R<sub>4</sub> and R<sub>8</sub>. Whether or not C12 is short circuited, can be checked by connecting the ohmmeter between the rectifier cathode and ground. If the condenser is shorted, a very low resistance will be indicated.

In checking the plate circuits, usually we check for continuity between each plate and the rectifier B+ output connection. In this set, an a.c.

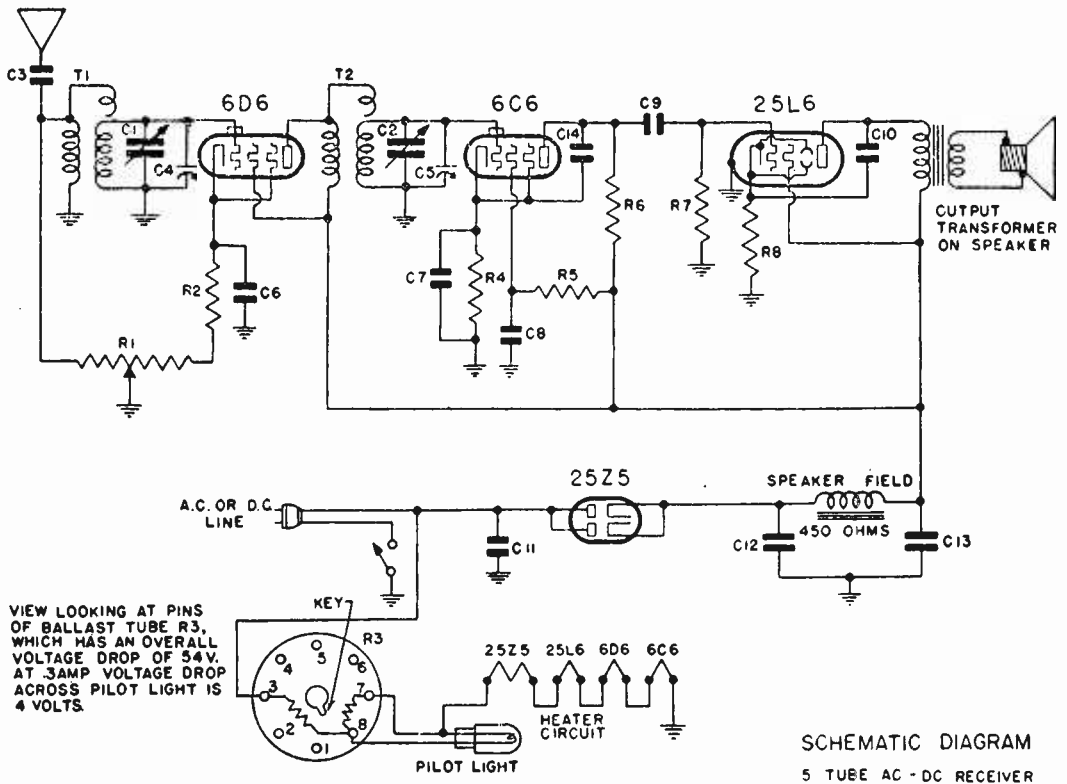

Fig. 17—Emerson BA-199

d.c. receiver, a cathode B+ connection to the rectifier tube is used. Therefore, we may put one ohmmeter test prod on the rectifier cathode connection of the 25Z5 and the other ohmmeter test prod on the plates of the 6D6, 6C6 and 25L6 tubes to check plate circuit continuity of the various stages. Doing this with respect to the 6D6, we should get a rather low resistance of the order of 450 ohms. The resistance of the primary of T<sub>2</sub> is small, negligible in comparison with 450 ohms. The R value between the 6D6 plate, therefore, and the rectifier cathode should be approximately 450 ohms. The resistance of R<sub>6</sub>, on the other hand, is appreciable, 500,000 ohms. Therefore, we should obtain a resistance of approximately 500,000 ohms when measuring between the 6C6 plate and rectifier cathode circuit. The value of 450 ohms is small compared with 500,000 and may be disregarded for this test. Between the 25L6 plate and the rectifier cathode a resistance equal to the primary resistance of the output transformer plus the speaker field resistance

should be indicated. Assuming a primary output transformer resistance of 100 ohms, and adding this value of 450 ohms, the resistance value would be approximately 550 ohms.

If we did not obtain an indication of continuity or proper resistance value, we would look for trouble in the plate circuit which did not show normal continuity and resistance. A very high resistance indication or no indication at all when the 6D6 plate circuit is tested would point most probably to an open in the primary of T<sub>2</sub>. If we obtained a resistance between the plate of the 6D6 and the screen of the 25L6, but no resistance indication between the 25L6 screen and the rectifier cathode, very likely the speaker field would be open.

If no indication of continuity is obtained between the plate and screen of the 25L6, the trouble very probably would be an open in the primary of the output transformer.

The voice coil of the loudspeaker may be checked for continuity. Putting an ohmmeter across the voice coil while the coil is connected to the secondary of the output transformer would not permit determining whether or not the voice coil was open. Note the low shunt resistance of the secondary of the output transformer in parallel with the voice coil. Therefore, to check the voice coil we must disconnect one lead and then apply the ohmmeter directly to the voice coil terminals.

The resistance and continuity tests of the circuits of an a.c.-d.c. receiver have been described. Now let's see how an a.c. receiver may be tested.

#### An A.C. Radio Receiver, Emerson BL-200

In this receiver the filaments are connected in parallel, with the exception of the 80 rectifier filament which is isolated from the remaining filaments. (Fig. 18.)

In order to check the amplifier tubes for filament circuit continuity, it is necessary to remove each tube from its socket and to apply the ohmmeter directly to the tube filament terminals or prongs. Also, a similar test is necessary to check the filament of the 80 rectifier tube.

The pilot lamp may be tested by removing it from its socket and applying the ohmmeter test prods directly to the pilot lamp electrodes.

If the pilot lamp socket is suspected of being defective, the socket may be temporarily disconnected from the circuit and then the continuity of the pilot lamp circuit can be checked directly by applying the ohmmeter to the pilot lamp wires.

In many cases, a continuity test is not required at all. Visual inspection may indicate whether or not the tube filaments are burned out since if the filaments are in good condition they will be lit. Also, the pilot lamp obviously will light if it has continuity and if the correct voltage is applied to it.

If all of the tube filaments light with the exception of one, say the 6A7, we would look for trouble primarily in the 6A7 circuit. A defective socket or a loosely fitting tube in the socket could cause the trouble.

The grid circuits of the 6A7, 6D6, 6Q7G and 41 tubes may be checked by putting one ohmmeter test prod on the chassis, the other on the 6A7 top cap, 6D6 top cap, 6Q7G top cap and, for the 41, pin terminal 4. Between the 6A7 top cap and chassis there will be the resistance of the secondary of T1 and of resistors R8, R9 and R10. These resistance values will add up. There will also

be a resistance path from the grid return of the 6A7 through R3 and R4. The values of R3 and R4 add up. The circuit consisting of R3 and R4 is in parallel with the series circuit of R8, R9 and R10. Therefore, the resistance between the grid return of the 6A7 and chassis will be less than the sum of R8, R9 and R10. If we wish, we may measure the secondary resistance of T1 by putting one ohmmeter test prod on the 6A7 top cap and the other ohmmeter test prod at the junction point of C11 and the secondary of T1. A simple and effective means of checking with one measurement the secondaries, of T1 and T3, is to put the ohmmeter test prods on the top caps of the 6A7 and 6D6 tubes.

The resistance measured between the top cap of the 6Q7G and ground should be the sum of R5 and R10. The resistance measured between the 41 grid and ground or chassis should be the sum of R7, R9 and R10. That is, the approximate resistance should be the sum of the resistance values mentioned. There will be a certain amount of shunting due to R9, R8, R3 and R4 which are in series, this series network being in shunt with R10. The effect will be slight, but we should appreciate it.

If we wish, we may check the individual resistance values by disconnecting wires and applying the ohmmeter directly to resistor terminals.

The cathode circuits of the various tubes may be checked by putting one ohmmeter test prod on the chassis and the other on each amplifier tube cathode. There should be a very low or zero resistance indication since the cathodes are all grounded.

The plate circuits may be checked by putting one ohmmeter test prod on one rectifier filament terminal and the other ohmmeter test prod on each amplifier tube plate. Between the 6A7 plate and the rectifier filament we measure the primary circuit resistance of transformer T3. This may be quite low in value, in typical sets ranging from 10 ohms to as much as 30 ohms. A similar value of resistance would be indicated when the primary of T4 is checked. One ohmmeter test prod is put on the 6D6 plate, the other on the rectifier filament. Between the 6Q7G plate and the rectifier filament we measure the value of R6. In this receiver it happens to be 250,000 ohms. In other sets it might range from 100,000 ohms to as much as 1 megohm, depending on the circuit design. Between the output tube (41) plate and the rectifier filament we measure the primary resistance of the output transformer. This value may range from 100 to 600 ohms, depending on the transformer design.

The rectifier plate circuit can be checked (receiver power off!) by putting the ohmmeter test

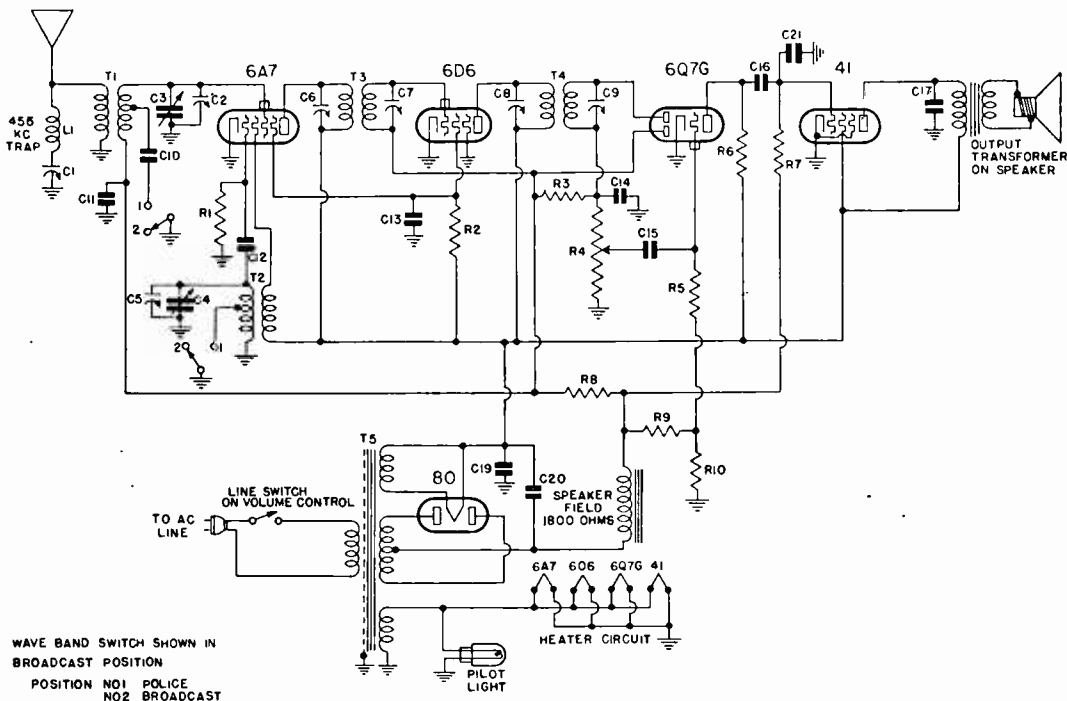

Fig. 18—Emerson BL-200

prods directly on the rectifier plate pin terminals. The resistance of the high voltage winding of the power transformer then will be checked. Approximately one-half of this value should be measured between each rectifier plate and the center tap. Then, from the center tap of the high voltage winding to the junction point of R8 and R9 we measure the speaker field resistance of 1800 ohms. Between the junction point of R8 and R9 and the chassis we should measure, approximately, the sum of the resistances of R9 and R10. These values are fairly low.

In this receiver R9 has a value of 290 ohms, R10, 35 ohms.

Resistance measurements help us to locate troubles in radio receivers. As an illustration, an open in R10 would prevent normal voltages being applied to the amplifier tubes of the radio. The set would not function. An open in the primary of the output transformer would prevent application of plate potential to the 41. An open in any of the other plate circuits would prevent the application of normal plate voltages.

Servicemen make frequent use of ohmmeter measurements for rapid point to point analysis of the condition of a receiver. You should become familiar with the technique of making resistance measurements, and interpreting your measurements.

One way of doing this is to practice resistance tests on receivers which you know to be in good condition, after making any initial repairs that may be required. In other words, don't pass up an opportunity to check the circuits of a receiver with an ohmmeter even though the set may be in good condition. The knowledge that you gain will prove helpful, later on, in servicing other sets.

— n r i —

She: "Sometimes my father takes things apart to see why they don't go."

He: "So what?"

She: "So you'd better go."

## Kinks and Short Cuts

(From page 12)

when solder has cooled to the point where it has "set," or changed to the solid state.

For example, melted solder has a bright shiny appearance which resembles mercury.

When melted solder cools to the point where it "sets," it changes its color and turns *white*. This change is *very pronounced*. You will learn to use it as a "stop signal," meaning that you will stop holding a tension on the soldered wires to keep them from moving until you are sure of having a solid connection.

Yes, these wires must be kept from moving. This is quite a problem in some instances where two or more wires are being soldered together. Of course, one or two wires often can be held readily with pliers against a terminal without running into trouble. However, if the ends of the wires refuse to stay in place, the simplest thing to do is to tie them together temporarily with a bare piece of No. 24 copper wire. Usually, you can remove this extra wire after the joint has been soldered but there is no harm in leaving it as a permanent part of the joint if you also have soldered it in place. Simply cut off the extra ends.

Frequently you may wish to remove solder from an eyelet or from the tip of a vacuum tube base. This can be done very easily by heating the part thoroughly and then *quickly* snapping the part which contains the eyelet. This rapid movement of snapping the part throws the solder out. Some practice may be required and often the procedure must be repeated several times until all of the solder has been dispelled. The "kink" is unsuccessful only if you wait too long between the time the heat is removed and the time that the part is snapped. The least trouble is experienced with larger parts where plenty of heat can be retained to keep the solder in a molten state within the eyelet.

Figure 5 shows a handy gadget made of wire and attached to a soldering iron which serves for a simple but effective stand. This wire stand is a time saver because it is permanently attached to the soldering iron and, therefore, it is ready for safely placing the heated iron anywhere on the workbench.

Specified dimensions are not important. Neither is the kind and size of wire of real importance. However, the approximate dimensions listed in the sketch will serve as a guide when making it, while it is suggested that aluminum or iron wire is chosen in preference to copper. This preference of the former kinds of wire will let the bottom of the stand remain absolutely cool although copper wire also can be touched with the hand without danger of scorching it.

Let us say you select a piece of No. 14 or No. 12 iron wire. The length can be seven inches or more. Bend this wire so you have about two inches at its center. Form a triangle by bringing the ends together, giving them a single twist, which will let this twisted joint be about one-half of an inch above the midpoint in the base. Then form the ends into a circle which fits around the metal handle, giving it another twist to hold it on the handle. This circular portion of the stand should fit loosely so the stand can swing freely. This will allow the base of the stand always to fall toward the bottom and, therefore, always be ready for placing it on the workbench.

If you need further elevation of the tip of the soldering iron, simply pull on the base which will give you greater clearance between it and the twisted joint, thus accomplishing your purpose.

Occasionally you may be required to remove enamel insulation from a wire or cable which

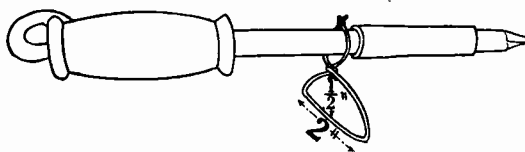

Fig. 5

consists of several strands insulated with enamel. Of course, you could scrape this enamel with a knife and accomplish a satisfactory job. However, this work can be done very easily if the enamel wire is heated in the flame of an alcohol torch. You will notice that the alcohol flame consists of two cones, one cone within the other. The inner cone of flame is decidedly blue while the outer cone contains a yellowish tint. Hold the enamel wire *within* but at the *tip* of the inner blue cone of the flame until the wire becomes red hot. No other place will do the job well. Then quickly remove the heated wire from the flame and plunge it into liquid alcohol. The tip of the inner cone is void of oxygen and, therefore, removes the enamel and oxide from the wire, while plunging the wire into the alcohol prevents tarnishing during the cooling process. Therefore, the wires which are prepared in this manner can be soldered without trouble resulting from tarnished surfaces and nicked wires.

If you do scrape enamel or other insulation from a wire, be sure that you do not scar or nick the wire. The slightest nick in a wire will weaken it to the extent where it will break if you bend it more than two or three times. However, if such nicks are absent, the wire can be bent an innumerable number of times.

In order to prevent making nicks in a wire while scraping, I recommend that you use the *back* edge of your knife. Not only does it prevent these troublesome nicks but it also saves the cutting

edge of the blade for purposes where a sharp blade is of greater importance.

Knives apparently are easily lost in a shop. I have never discovered just where or how they disappear, but I do know from experience that it is a difficult thing to keep a good knife on hand. I have often solved my problem by making my own knife from the broken blade of a hacksaw. Simply grind the edge of the saw on an emery wheel. This sharpened blade can be used without attaching an extra handle. However, I find it more convenient to form a handle by laying two thin sticks along the blade, and then wrapping the entire assembly with one or two layers of friction tape.

You may be interested in placing the stickiest side of the tape nearest the smoothest surface which happens to be the blade in this case. You may need to know which is the stickiest side. Grasp the tape between the thumb and forefinger, then separate them. You will soon find out now which is the stickiest side, because this side will remain clinging to either the thumb or forefinger.

Taping wires and soldered connections will be done very neatly in the average case of radio servicing if you will use tape which is about three-eighths of an inch wide. Most commercial tape is double this width. Therefore, if you will tear this standard tape in half, lengthwise, you will accomplish your purpose.

Tape attached at the ends of braided wires and lampeord will prevent the braid from unraveling and becoming unsightly. The narrow width of tape described above also is effective for this purpose. However, I prefer to make a neater and cleaner job by using a good grade of string or sewing thread of the variety used ordinarily for sewing on buttons. This string is placed over the end of the braid and tied with an *invisible knot*. Figure 6 shows the details for making this invisible knot. Notice that you first form a loop of the string which is laid lengthwise along the braided wire. Then take the longest or No. 6 end of this loop and wind it in a circular manner around the braid which also covers the two ends, No. 1 and No. 3, continuing to wind the string *toward* the loop at No. 2 until half an inch or more is covered. Then insert the longer No. 6 end of the string into the No. 2 loop, pulling on the other or shorter No. 1 free end in order to decrease the size of the loop and thus draw the longer No. 6 end *under* the wrapping. You will find then that you have only the No. 1 and No. 6 ends showing at each end of the wrapping. Cut these ends close to the wrapping and the ends will become invisible, with the knot underneath.

When installing aerials, you will have to uncoil the wire which you have purchased for this purpose. It should be and *can be* uncoiled easily so the finished job is free of kinks and coils. No

doubt you are aware that if you draw the wire from either the inside or the outside of the coil, you will have a spiral wire. However, if you draw the wire from the *outside* of the coil for three turns, then turn the coil all the way over and release three more turns, these coils will be in *opposite* formation and, therefore automatically unwind the original coils. By repeating this process of turning the coil all the way over for every three turns which are released, the entire length of wire will be free from coils.

Occasionally you may need a short threaded bolt or screw although a long one only is available. The natural thing to do is to cut the bolt to the required length with a saw, or probably with a pair of pliers. However, the average serviceman may have trouble in getting a nut to fit the threads after this much of the job has been completed. The reason is that the first turn of the cut portion of the thread has been damaged and distorted on the bolt, so the threads in the nut can not take hold.

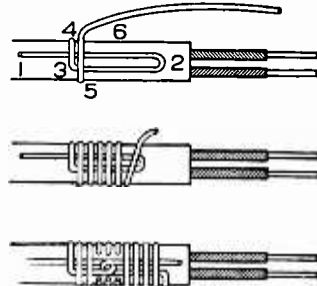
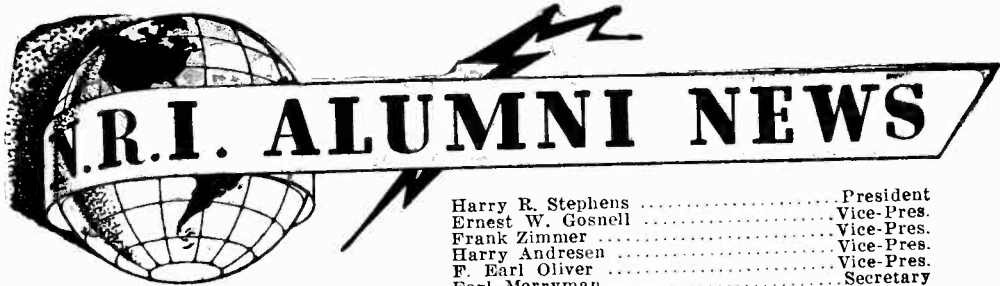

Fig. 6

In order to prevent trouble of this kind, place a nut on the screw *before* the screw is cut. After the cut has been finished, *remove* the nut. This process will restore the damaged thread because the nut will readily force any projection out of the way while it is being removed. Then, when the nut is replaced in actual use, it can be put on without trouble.

Fastening toggle switches, volume controls and potentiometers to the panels of a receiver often can be done better without the aid of pliers and wrenches. This will avoid scarring the panel or the retaining nuts on the front of the panels and make a neat appearance. The thing to do is to first put on the nut in the regular way with your fingers and then tighten this nut by *turning the device itself from the back of the panel*. Due to the larger diameter of the part itself, very little pressure exerted here with your fingers will have greater effect than pressure applied with a wrench or pliers at the nut on the front of the panel. Therefore, simply tightening the part with the aid of your fingers will make a neater and tighter job than using mechanical aids.



Harry R. Stephens .....	President
Ernest W. Gosnell .....	Vice-Pres.
Frank Zimmer .....	Vice-Pres.
Harry Andresen .....	Vice-Pres.
F. Earl Oliver .....	Secretary
Earl Merryman .....	Executive Secretary
Louis L. Menne .....	

# OFFICERS OF THE NRI ALUMNI ASSOCIATION



**EARL A. MERRYMAN**  
Secretary



**HARRY R. STEPHENS**  
President



**LOUIS L. MENNE**  
Executive Sec'y



**F. EARL OLIVER**  
Vice President



**ERNEST W. GOSNELL**  
Vice President



**HARRY ANDRESEN**  
Vice President



**FRANK ZIMMER**  
Vice President



## New York Chapter

Following is a running report of proceedings at New York Chapter meetings.

Pete Peterson opened the Suggestion Box and answered all questions. At this meeting Frank Zimmer, National Vice President and a product of New York Chapter, gave us quite a talk. After the meeting Frank Zimmer entertained us as his guests in celebration of his election. Forty-nine were present at this meeting.

We held our election and all officers were re-elected for another term. It was a real tribute to these men who have done such a fine job for New York Chapter during the past year.

James Newbeck began his series of talks on Frequency Modulation. These talks continued for several meetings but were interrupted when Jimmie Newbeck was taken to the hospital because of illness. He is now back home and will soon meet with us again.

Andrew Antosh spoke on some of his radio experiences. It was an interesting home-spun talk. He was followed by our good friend, William Fox, who gave us a talk on the humorous side of Radio.

A new member of our Executive Committee is Alexander Remer who has been a member of our Chapter for quite some time and has been very active.

About a year ago our members decided to present a gift to the outstanding member of the year. This decision was left to the Executive Committee. It was a difficult decision to make and after a lengthy discussion we decided it would be necessary to give two gifts instead of one. Chairman Wappler made quite a speech in presenting the gifts to Eugene Williams who received a condenser testing box and George Woodward who received a complete set of tubes for an ac-dc receiver. These members deserved this honor.

Lawrence Jordan is the most recent war veteran to be back with us and Ralph Baer is expected home soon.

Meetings on the first and third Thursday of each month at St. Mark's Community Center, 12 St. Mark's Place, between 2nd and 3rd Aves., New York City.

LOUIS J. KUNERT, *Secretary*.

— n r i —

"If you want knowledge, you must toil for it; if food, you must toil for it; and if pleasure, you must toil for it. Toil is the law. Pleasure comes through toil, and not by self-indulgence and indolence. When one gets to love work, his life is a happy one."

JOHN RUSKIN.

## Detroit Chapter

We have purchased a 16mm sound projector and amplifier. Harry Stephens, Harold Chase and Chairman James Quinn acted as a committee and after a complete demonstration decided that the projector and amplifier was just the thing for Chapter meetings. Chase is familiar with projectors having formerly been an operator so at once we have the equipment and an expert to operate it. The machine can be used as a public address system with microphone and record player input.

Because of the new equipment and excellent screen, which we also purchased, we have been seeing some very nice pictures at our meetings. Our Chairman is arranging for additional pictures. All of them will demonstrate some operation related to radio. This visual education feature of our meetings is very popular.

Two new members are Duncan Jacques and John Bray.

Mr. Henry Rissi who is a noted Detroit serviceman and also an honorary member of Detroit Chapter, varied the usual procedure by having each member ask a question which he answered. There were 34 present at this meeting and it was indeed a very interesting session. The questions and answers brought out a lot of good points.

It has been decided to hold an open forum meeting for thirty minutes before the regular meeting at 8:30 P.M. to discuss one lesson of the fundamental NRI course. It is hoped to cover about seventeen lessons during the present year. This will be a refresher course for graduates and most certainly will prove beneficial to newer students. It is a great opportunity for students to get the benefit of the experience of older radio men.

It should be mentioned that some very fine films for our projector were contributed by Engelman's Visual Education Service, 701 W. Warren Ave., Detroit.

Chairman Jim Quinn is putting a lot of punch into his work and our sessions are very interesting.

We meet at John Stanish's place, 2500 Jos. Campau Street in Detroit on the first and third Friday of each month. The undersigned will be glad to send notices to any NRI man in this territory who would like to attend meetings. Address —13103 Stoepel Ave., Detroit 4, Mich.

VAL GUYTON, *Secretary*.

— n r i —

"There has never been a man in our history who led a life of ease whose name is worth remembering."

THEODORE ROOSEVELT.

# NEW YORK CHAPTER AT PLAY



"I'll attend the meeting. Bring out the caviar, and champagne," wrote Chief Dowie in jest, and that is exactly what he got with Peterson doing the honors.



Lou Kunert and Bert Wappler stand by while Charley Fehn, 1945 Alumni President, speaks. Fehn made the trip from Philadelphia.



Some of the good looking members of New York Chapter. More than 100 were present at this meeting.

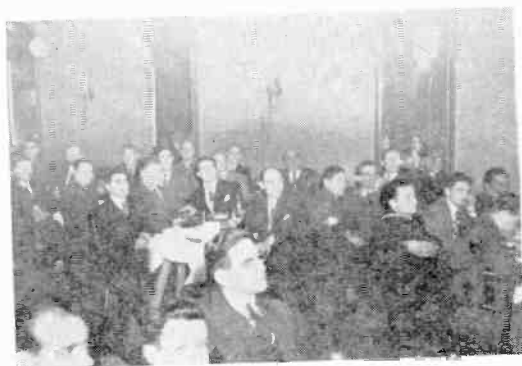

Another group, apparently intensely interested in the proceedings. A large picture of the entire group, unfortunately did not develop.



Lou Kunert, J. B. Straughn, Frank Zimmer, Lou Menne, Bert Weppler, J. A. Dowie, and Pete Peterson in close "harmony."



That irrepressible quintet of live-wires—Kunert, Wappler, Krause, Zimmer and Peterson were always doing something. Never a dull moment in New York Chapter.



Chief Instructor J. A. Dowie, guest of honor, at the microphone.



Frank Zimmer, one of our Vice Presidents, delivers a very inspiring talk.



Lou Menne, Executive Secretary, letting himself go and enjoying himself immensely.



Bert Wappler, popular Chairman of New York Chapter, whose energy seems to know no bounds.

## Chicago Chapter

We have been meeting at our new headquarters in the Garfield Park Administration Building (The Golden Dome), 100 North Central Park Ave.

Mr. Curtis Willard and Mr. Allen Johnson, Engineers with the Webster Co. of Chicago gave us a two hour talk and demonstration on Record Changers. This was a very interesting meeting.

Officers for the current year are as follows: Chairman: Harry Andresen, 3317 N. Albany Ave.; Secretary: Harry Coltun, 1225 W. Lunt Ave.; Treasurer: Steve Boguar, 4443 W. Cortez St.; Librarian: Lloyd Immel, 2306 W. 51st St.; Sgt.-at-Arms: J. Wiesmeyer, 141 Roberts Ave., Melrose Park, Ill.

We are delighted to see a number of former members back with us after returning from military service. Mr. Clark Adamson, our former Treasurer, and Chas. Cada, also a former office holder, are two in the group. Mighty glad to have these good workers back in the Chapter.

Our ever reliable friend, Mr. Milton Coleman of Radolek Co., is frequently present at our meetings and always contributes something worthwhile in the way of practical radio information. He also has been very liberal in making donations of some useful radio items which we raffle off as a door prize.

If you live in this area and are interested in attending meetings we shall be glad to have you send your name and address to the Chairman or Secretary as listed above.

HARRY COLTUN, *Secretary.*

## Baltimore Chapter

Our new Chairman, Mr. A. J. Rathbun, who is a thoroughly capable radio serviceman, is giving us some mighty fine meetings. He knows what we want and he comes prepared to give it to us. Vice President E. W. Gosnell meets with us regularly and contributes what he can to give spice to the proceedings.

Our Vice Chairman, Mr. Larry Arthur, gave us a talk on the Cathode-Ray Tube. Chairman Rathbun talked on the action and principles of the Magic Eye. After each talk the members are requested to ask questions and we then have a lively informal session.

It surely behooves any NRI student or graduate in this vicinity to pay us a visit and join our Chapter. He surely will be helped along with his knowledge of radio and as a member he will meet a fine bunch of fellows. There is much in

fraternizing with fellows who are interested in the same line of endeavor.

Meetings are held on the second and fourth Tuesday of each month at Redmen's Hall, 745 West Baltimore St., at 8:15 P.M.

PERCY MARSH, *Secretary.*

— n r i —

## Phila-Camden Chapter

Meeting regularly at our headquarters in the Post Office Building, 4706 Comly Street, Philadelphia, on the first and third Thursday of each month.

We have a committee at work for the purpose of adding some testing equipment. It is our policy to have as many actual demonstrations as possible—to do real radio service work so that our members can acquire a professional technique.

Philadelphia Chapter is going along very nicely. Students and graduates in this area should keep our meeting dates in mind and take advantage of the opportunity to meet with us. All NRI men are welcome.

F. ARMSTRONG, *Secretary.*

— n r i —

## A Message from the Alumni President

TO ALL ALUMNI MEMBERS:

First, may I please express my deep appreciation for the honor bestowed on me by the members of the National Radio Institute Alumni Association in electing me as President for the year 1946. My sincere appreciation also to the many Detroit Chapter members and to our retiring President, Mr. Charles J. Fehn.

To me, it has been an honor to be a member of the Alumni Association, and now to be its President I am doubly honored. I sincerely hope that I can justify your choice in some way which will benefit the Association.

The N.R.I.A.A. has a number of fine chapters, and all graduates (and students also), who are located in the vicinity of one of the chapters should be sure to join and reap the benefits. You owe it to yourself, if only for the good *you* can get out of it. There is a lot of real fraternal spirit shown at these chapter meetings, so if you don't join you are missing plenty.

I wish to extend my sincere best wishes to the National Officers, the Local Chapter Officers and to all members everywhere. I will welcome letters from any who care to write. Address me at 5910 Grayton Road, Detroit 24, Michigan.

Sincerely yours,

HARRY R. STEPHENS, *President*  
NRI Alumni Association.



## Here And There Among Alumni Members

H. C. Wenzel, who operates Wenzel's Radio Service, 224 Main St., Windsor Locks, Conn., is in need of the services of a good

Radioman to take care of the increase in business.

— n r i —

*Earl R. Holmes is employed in the service department of A. K. Sutton, Inc., Charlotte, N. C. He is Assistant Service Manager and is ready to step up to Manager.*

— n r i —

Raymond G. Brown of New York City is a musician by profession and does very well at it financially. He is doing Radio servicing work in his spare time and has plans for opening his own full time Radio business in the future.

— n r i —

*Raymond N. Clark is Assistant Engineer at Radio Station KRLH, Midland, Texas. There is a young man who is going places in Radio. Has lots of get-ahead.*

— n r i —

Owen W. Brown works for Farnsworth Television and Radio Corporation, Marion, Indiana, in the Test Equipment Engineering Department.

— n r i —

*A big vote of thanks to John Stanish, former Chairman of Detroit Chapter and former National Vice President, who provides meeting headquarters for Detroit Chapter, rent free. John has donated this space for many years and we want him to know how much we appreciate his fine fraternal spirit.*

— n r i —

William Crawford of Bellaire, Ohio, recently completed the NRI Course and is planning to go into the Radio Service business, after working for twenty-one years at the Willow Grove Mine. Good luck!

— n r i —

*W. Edmonson of Piermont, New York did a part time Radio business while Chief of Police. His Radio business developed so well he resigned as Police Chief to give all his time to his Radio store. His Radio earnings have doubled those of his previous position.*

— n r i —

Harry Katz is patiently waiting for his Navy discharge to go back to his job on the engineering staff of WINX, here in Washington, a position for which he gives credit to NRI training. Mr. Katz has a Radiotelephone first-class license.

*Stewart Godfrey of St. Johns, Michigan, a very recent graduate, contracted Polio in September, 1942 and is still confined to a wheel chair. Notwithstanding his physical handicap he is doing a splendid Radio business. He believes in advertising and knows how to put a sales message on paper. His motto "Early to bed, early to rise, work like ——— and advertise!"*

— n r i —

Pete Baumert of Youngstown, Ohio is now affiliated with Ben's Modern Appliances, Inc. Sent us a photo showing their seven Radio technicians. Of these, three are NRI men. They do an enormous volume. In the last nine months, they have repaired approximately 3500 radios.

— n r i —

*Walter Strahlendorf owns and operates Walter's Radio Sales and Service, West Hamilton, Ont., Canada. He left the old country only 15 years ago. Up to the time he was forty years of age he worked very hard in factories. He decided to do something about it. Took up Radio and for the last two years he has had his own business which is steadily growing.*

— n r i —

James Newbeck, who is the business partner of Pete Peterson, both very active in New York Chapter, while on his way to their store one morning a few weeks ago, collapsed in the subway and was rushed to a hospital. Was operated on immediately for a perforated ulcer. Quite low for awhile but, at last reports, he was on the road to recovery.

— n r i —

*Terence S. Yon, c/o T. J. Yon and Sons, P. O. Box 80, Umtali, S. Rhodesia, S. Africa is doing a very nice Radio business. He is a very enthusiastic Alumni member and would like to correspond with fellow members in Africa.*

— n r i —

Harry Andresen, Vice President of the Alumni Association this year and also Chairman of Chicago Chapter was unable to attend a meeting because of illness. It was the first meeting he has missed in five years. Mighty good record.

— n r i —

*Back in Washington, D. C., and enjoying good health again is Earl Merryman, our very popular Alumni Secretary. Earl asked the Editor to see that his thanks are extended to all Alumni members for reelecting him Secretary for the seventeenth consecutive time. Earl is very proud of his office as Secretary of the Alumni. What we want Earl to know is that we are the proud ones—proud to have a fine Radio man with a grand war record, back home and just about fully recovered from his war disability. We know that all Alumni members wish you the best of everything, Secretary Earl Merryman.*

## Allied Releases, 1946 "Buying Guide"

Allied Radio Corporation, Chicago, announces the release of a new 1946 catalog, "Everything in Radio and Electronics." Allied's first post-war catalog includes over 10,000 parts, test units, batteries, radios and phonographs, public address and intercommunication equipment, recorders and accessories, communications receivers, kits, record changers, phonograph motors, tools, and a large variety of other items in the electronics field for the radio serviceman.

This 1946 catalog is available free on request from Allied Radio Corporation 833 West Jackson Boulevard, Chicago 7, Illinois. Write direct to Allied for this catalog, not to NRI.

— n r i —

## Antenna Data Brought Up To Date

Antenna systems properly geared to new and old radio sets alike, as well as to those FM, Facsimile and Television Receivers now beginning to appear on the post-war market, are included in the 1946 Taco Catalog just released by Technical Appliance Corporation.

The catalog describes, illustrates and lists various noise-reducing and multiple antenna systems, a new store-demonstrating antenna system, transmission lines, couplers, and a variety of dipoles, thereby covering the entire known range of reception needs. A copy of this catalog may be had by writing to Technical Appliance Corp., 46-06 De Long Street, Flushing, N. Y.

— n r i —

## Experience!



Sure I remember I was young once—wadda you think I'm chasing him home for?

Page Thirty-two

# NATIONAL RADIO NEWS

FROM N. R. I. TRAINING HEADQUARTERS

Vol. 12

April-May, 1946

No. 2

Published every other month in the interest of the students and Alumni Association of the

NATIONAL RADIO INSTITUTE  
Washington 9, D. C.

The Official Organ of the N. R. I. Alumni Association  
Editorial and Business Office, 16th & You Sts., N. W.,  
Washington 9, D. C.

L. L. MENNE, EDITOR

J. B. STRAUGHN, TECHNICAL EDITOR

NATIONAL RADIO NEWS accepts no paid advertising. Articles referring to products of manufacturers, wholesalers, etc., are included for readers' information only, and we assume no responsibility for these companies or their products.

## Index

Article	Page
Initiative . . . . .	2
How to Remove the Chassis from the Cabinet . . . . .	3
Kinks and Short Cuts in Radio Servicing . . . . .	10
Service Sheet—Ward's Airline . . . . .	13
Radioautobiography . . . . .	15
Basic Principles in Resistance Measurements . . . . .	16
Officers of NRI Alumni Association . . . . .	26
Chapter News . . . . .	27
New York Chapter at Play . . . . .	28
Here and There Among Alumni Members . . . . .	31