



- A Venture Into CB Moonlighting
- 1976 Hugo Gernsback Awards
- More About Servicing Record Changers
- More Adventures in TV Servicing



journal
September/October 1976

Keep in touch...
wherever you are

...with the
first
portable
radio
with
built-in
TV!



...from **JVC**

This super-compact three-band FM/AM/PSB radio with built-in TV won't let you miss anything that's happening—anywhere it's happening. News, music, sports, weather reports, fire and police calls—all are right there at the flick of a switch.

It's not just a radio—not just a TV

The JVC 3050 is really two sets in one. It's an FM/AM/Public Service Band radio with a big five-inch wide-range speaker, with separate bass and treble controls for custom-tailoring the sound. And it's a sensitive all-channel vhf-uhf TV set, bringing you a bright, clear, sharp picture on its optically-tinted, three-inch diagonal picture tube.

Works wherever you are

Weighing less than eight pounds, this versatile little entertainment center can be powered four ways—on ac with the power pack supplied, or with the adapter cord included for car/boat/plane use. And you can enjoy up to eight hours of TV on six regular D-cells—or up to twelve hours with a Nicad rechargeable battery pack. So don't delay—use the order blank at the back of the Journal to order your JVC 3050 today!

- High sensitivity and selectivity with IC and ceramic filters
- Extrasensitive vhf/uhf tuner section with varactor diode
- Full-fidelity five-inch speaker for rich, full sound reproduction
- Independent bass and treble controls tailor sound to your taste
- Jacks for connecting tape recorder, earphone, or optional timer
- Two-way meter indicates battery power level and radio signal reception
- Switchable dial light for night tuning
- AGC circuit helps eliminate fuzziness, instability, and noise
- Personal-size optically-tinted three-inch diagonal picture tube
- Telescoping antenna
- Double-duty carrying handle and TV stand
- Four-way power—AC (with power adapter), D-cells, car cord for boat/car/plane, and Nicad rechargeable battery pack (optional)
- 10" high by 8-7/8" wide by 4-1/8" deep. 7.7 pounds.

Only **\$199⁹⁵**

Plus \$2.50 shipping
and insurance

Stock No. EN305

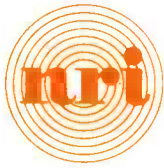

journal

September/October 1976
Volume 34, No.5



<i>Harold Kinley</i>	2	A VENTURE INTO CB MOONLIGHTING
	8	THE 1976 HUGO GERNSBACK AWARDS
<i>Harold Pierce</i>	9	MORE ABOUT SERVICING RECORD CHANGERS
<i>J. B. Straughn</i>	11	MORE ADVENTURES IN TV SERVICING
<i>Ted Beach</i>	19	HAM NEWS
	24	NRI HONORS PROGRAM AWARDS
<i>Tom Nolan</i>	26	ALUMNI NEWS

EDITOR AND PUBLISHER
William F. Dunn

TECHNICAL EDITOR
Ted Beach

MANAGING EDITOR
Tom Beadling

EDITORIAL ASSISTANT
Mildred Duncan

STAFF ARTISTS
Bill Massey
Arthur Susser
Ernie Blaine

In this issue, NRI grad Harold Kinley tells us how he turned on to CB moonlighting, NRI grad Harold Pierce adds a bit on servicing record changers, and longtime Journal mainstay J. B. Straughn gives us some more of his fascinating insights in his continuing anthology of TV servicing case histories.

The NRI Journal is published bimonthly by the National Radio Institute, a division of the McGraw-Hill Continuing Education Center, 3939 Wisconsin Avenue, Washington, D.C. 20016. The subscription price is two dollars yearly or 35 cents per single copy. Second-class postage is paid at Washington, D.C.

a
venture
into

CB

Moonlighting



Harold Kinley C.E.T.

We were pleasantly surprised to receive the following article from NRI graduate Kinley (Class of '76, Complete Communications Course, with high honors), who wasted little time in putting his NRI training to work for him. Besides his growing CB servicing operation, Mr. Kinley is employed by the South Carolina State Commission of Forestry and is in charge of all two-way communications equipment in his district.

Although I had been working in the communications field for several years, I had never really done any appreciable amount of moonlighting work until I began my spare-time CB servicing business this year.

Because I live in a rural area which lacks any sort of CB servicing facilities, I had for some time been receiving requests to repair CB equipment. These I had rejected, pleading lack of servicing equipment. However, under pressure

from the inflation which besets us all, I finally decided to take the gamble by using my income tax refund and rebate to establish a moonlight CB service shop in my garage.

I began with the bare necessities, and at first I reinvested nearly all my profits in remodeling my garage/shop and in stocking up on replacement parts.

To begin with, I already owned a Conar scope, a Conar vtvm, a Heathkit vom, and a transistor-checker I had built to work with my scope. I decided that the basic units of test equipment I still needed to purchase were (1) a frequency counter, (2) a good signal generator, (3) a multipurpose transceiver tester, and (4) a good battery eliminator. I also needed some service information, and for this purpose I purchased a complete set of Sams CB radio manuals.

For the frequency counter, I chose a Heathkit IB1100, which was well-suited for this type of work.

For the signal generator I purchased a Heathkit IG42 laboratory generator. I found that the output of the IG42 could not be controlled down to a low level at 27 MHz because of rf leakage past the attenuators. However, I found that by tuning the generator to a subharmonic of 27 MHz (9 MHz) I could obtain a low-level output of 27 MHz. After

making some comparisons on several radios in good working order, I learned where to set the output level on the generator for checking the approximate sensitivity of receivers.

For the multipurpose transceiver tester I chose the E. F. Johnson transceiver tester. This tester serves as an rf wattmeter, a percent modulation meter, an swr meter, a relative field-strength meter, a crystal checker, and a dummy load.

It also contains an rf signal generator on the CB band, the frequency being determined by an external crystal. The rf signal can also be modulated by a 1000-Hz audio generator which is built into the unit. The tester is compact and portable and has worked out very well for me.

For the battery eliminator I bought the Eico Model 1060S, which has faithfully served many long hours on the test bench. I also built a dummy load in a Bud minibox using eleven 560-ohm 1-watt carbon resistors in parallel. I also made provisions on the "load box" for feeding the 27-MHz output signal from the dummy load to the vertical plates of my Conar scope. In addition, I made provisions for feeding a signal to the frequency counter for checking channel frequencies. The schematic for the load box is shown in Figure 1.

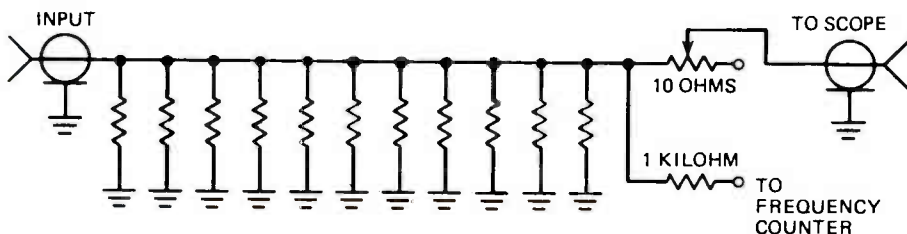

FIGURE 1. THIS DUMMY LOAD CONSISTS OF ELEVEN 560-OHM RESISTORS IN PARALLEL. THE VARIABLE RESISTOR IS USED TO CONTROL THE AMPLITUDE OF THE SIGNAL FED TO THE VERTICAL PLATES OF THE SCOPE. THE 1-KILOHM RESISTOR IS USED TO FEED THE FREQUENCY COUNTER. THE ENTIRE UNIT IS CONSTRUCTED IN A BUD MINIBOX.

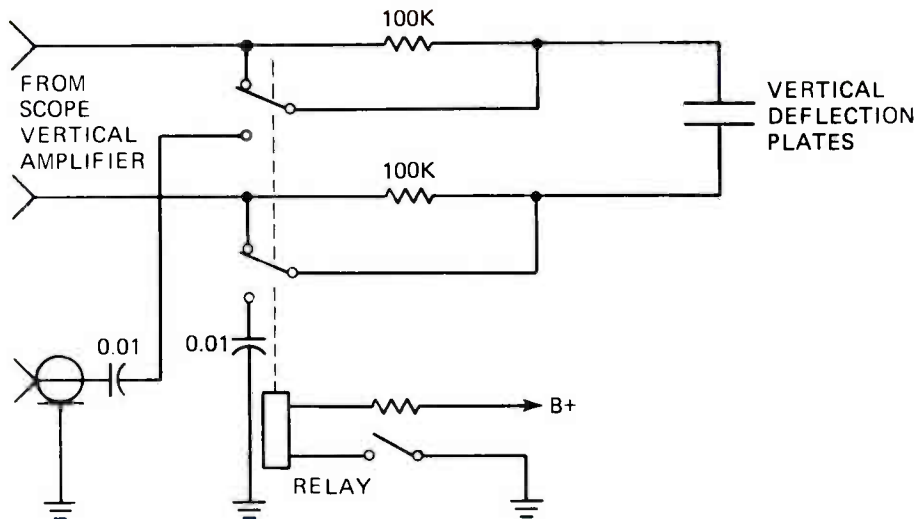

FIGURE 2. A PARTIAL SCHEMATIC SHOWING THE MODIFICATION MADE TO MY CONAR SCOPE TO GIVE ME ACCESS TO THE VERTICAL PLATES FOR VIEWING THE 27-MHZ CB OUTPUT SIGNAL AND ITS MODULATION ENVELOPE. THE 100-KILOHM RESISTORS ALLOW THE SCOPE'S VERTICAL CENTERING CONTROLS TO OPERATE WITH THE VERTICAL AMPLIFIER SWITCHED OUT OF THE CIRCUIT. I SUPPOSE THAT A DOUBLE-POLE SINGLE-THROW SWITCH COULD HAVE BEEN USED INSTEAD OF THE RELAY, BUT I USED THE RELAY TO KEEP THE LEADS FROM THE VERTICAL AMPLIFIER AS SHORT AS POSSIBLE.

I also made a modification to my Conar scope which gives me access to the vertical plates in order to observe the modulation pattern. I could not run the 27-MHz signal of a CB set through the vertical amplifier of the scope because the vertical amplifier in this type of service scope doesn't have the bandwidth for passing a 27-MHz signal through its vertical amplifier.

However, with the signal fed directly to the vertical plates the 27-MHz signal and its modulation envelope can be observed on the scope. The modification to the scope is shown in Figure 2. The SO239 coaxial socket is installed on the front panel of the scope, as is the relay switch.

With this assembly of test equipment (see Figure 3) I felt ready to begin my moonlighting.

From the beginning I made it a habit

to check out mobile sets in the vehicle before removing the set to the workbench. Many times this quick check reveals antenna trouble, and had I not made a check the customer would have driven off with the trouble.

Most users of CBs install their own antennas and often do it incorrectly before bringing the job to me. I often find that the installer did not make the hole large enough to keep the whip from shorting to the body of the vehicle. I also often find improperly installed coax connectors, ground connections, and "floating" shields.

As far as the radios themselves are concerned, I have run into quite a variety of troubles. I'll describe some of the more common ones here.

One common complaint is that the set blows fuses. This occurs most commonly when the set is inadvertently hooked up



FIGURE 3. (L. TO R. ON SHELF) HEATHKIT IB1100 FREQUENCY COUNTER, CONAR MODEL 211 VTVM, HEATHKIT IG42 SIGNAL GENERATOR, JOHNSON TRANSCEIVER TESTER, HEATHKIT MODEL MM1 MULTIMETER, AND JOHNSON 123A CB TRANSCEIVER. (L. TO R. ON BENCH TOP) CONAR MODEL 250 OSCILLOSCOPE, EICO MODEL 1060S BATTERY ELIMINATOR, AND NIKOLTRONIX CB ANALYZER.

with the polarity reversed. Some of the large trucks have positive-ground batteries which require the connections to the radio to be reversed. On these, the fused line would go to the ground and the unfused line would go to the ungrounded side of the battery.

Most sets with two power leads can be hooked up as either positive or negative ground, because the common ground in the radio is dc-isolated from the chassis ground. Sets which have only one power lead are usually negative ground only unless a polarity-reversing switch is provided on the set.

Most radios have a "polarity protection" diode, as shown in Figure 4. This diode is forward-biased when the polarity is wrong and the high forward current causes the fuse to blow, thus protecting the radio from extensive damage. Fairly

often the protection diode shorts when the polarity is reversed because of the high current flow. When this happens, the diode must be replaced.

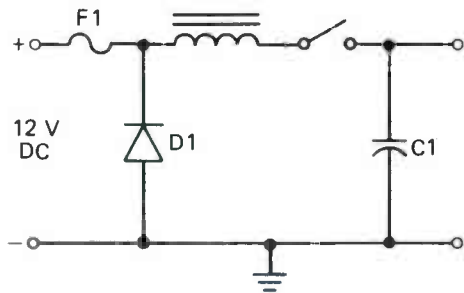

FIGURE 4. PARTIAL SCHEMATIC SHOWING THE POLARITY DIODE AND THE LARGE ELECTROLYTIC CAPACITOR WHICH EXPLODED WHEN THE POLARITY WAS REVERSED.

I have seen a case where the radio had been hooked up backwards, the protection diode conducted and blew the fuse, the fuse was then bypassed, and the radio reconnected backwards again. This time the diode overheated and opened up, and then the surge of reversed polarity voltage literally blew up the large electrolytic filter capacitor. So whenever someone brings in a radio that is blowing fuses, I first suspect the protection diode.

Another very common trouble is defective microphone cartridges, especially the ceramic type. For some reason, I have found the little Johnson ceramic microphone cartridges to give the most trouble. If the modulation is low or distorted but the radio receives loud and clear, I usually replace the mike cartridge first thing, and in most cases this is all that is needed.

I try to keep some of the Johnson cartridges in stock because the turnover is high. I tried to use some less expensive cartridges but they did not have sufficient output, so now I use only the Johnson replacement cartridges. The dynamic cartridges are apparently much more durable than the ceramics, because so far I've run across only two or three bad ones.

Fairly often a set comes in the shop with the complaint that it receives fine but doesn't transmit. The first thing I do is check the power output with my transceiver tester.

If the meter gives little or no indication, I turn on my own CB set and place it near the set under test, with both sets on the same channel. Next I key the set under test to see if my set will pick up a signal from the defective set. If my set receives a signal from the defective set, this tells me that the oscillators are functioning. The trouble is probably in the rf driver or output stage. It usually turns out to be a bad transistor in one of these stages.

On several occasions I have found the synthesis oscillator transistor to be defective. When this happens, the set will not

transmit or receive because the synthesis oscillator is common to both the transmitter and receiver.

Also, another point to keep in mind about sets using frequency synthesis is that when one crystal goes bad, several channels are affected. The affected channels could be four channels apart or could be four consecutive channels. My experience has shown that the higher-frequency crystals give the most trouble.

Microphone cords are also a frequent source of trouble. Usually there is just one broken wire in the microphone cord, and most often the break is near the point where the cord enters the microphone. The break can often cause the trouble to be intermittent and cause very erratic operation.

A broken wire in the cord can cause loss of receiver audio, loss of modulation, or inability to key the transmitter. There are other possible symptoms, but these are the most common. When I suspect a broken wire in the microphone cord, I grasp the cord near the microphone and wiggle it in all directions while checking for the symptom. I also do this near the plug or near the point where the cord enters the radio. The cure is to cut the entire cord and reconnect it to the microphone or the plug.

I should point out that my setup is good for servicing AM CB sets only. I haven't had a great demand for service on the single-sideband sets as yet. When the demand justifies it, I will probably purchase single-sideband test equipment. I would need a good peak-reading wattmeter and an ssb signal generator.

I recently purchased a 23-channel crystal-controlled generator. This eliminates the necessity of having to set the variable frequency generator with the frequency counter, which can be very time-consuming when you want to check several channels.

The Dynascan Corporation has recently come out with a CB Servicemaster



FIGURE 5. CHECKING POWER SUPPLY RIPPLE IN JOHNSON 223 TRANSCEIVER USING OSCILLOSCOPE.

and CB Servicecenter. These instruments can check both ssb and am CB sets. I am glad to see these new additions to the CB test equipment line, as they are much needed and long overdue.

In this article I have tried to relate briefly how I started CB moonlighting and some of the more typical troubles I have encountered. I am well pleased with the response I have received in my spare-time CB servicing business.

If you are in the communications electronics field or have knowledge in this area, and are feeling the inflation pinch or just want to try your hand at establishing your very own business, you may also want to give some consideration to CB moonlighting. (Remember, you must have at least a Second Class license to perform such servicing by yourself.)

If you do, the very best of luck to you . . . and I'll "CB-ing" you!

Heart Disease.

You can live without it.

Give Heart Fund 
American Heart Association

The

1976

Hugo Gernsback Award Winners

NRI is proud to announce the winners of the 1976 Hugo Gernsback Award. Since 1971, NRI has cooperated with Radio-Electronics Magazine in making this annual scholarship award of \$125 to a deserving student currently enrolled in NRI. The award is applied toward furthering the selected student's education in electronics. Runners-up receive gifts of electronic equipment through the generosity of RCA Electronic Components. NRI is one of eight home-study electronics schools chosen to perpetuate the scholarship, established by Radio-Electronics in memoriam to Hugo Gernsback, its founder and a notable pioneer in electronics.

Americans have always prided themselves in their ability to overcome adversity, and it is therefore perhaps appropriate in this Bicentennial year that our winner of the Hugo Gernsback Award is Bob Bartlett of Walton, New York.

Bob, who was born and raised in Walton and graduated from high school there, had successfully operated his own dairy farm for eight years when, in 1968, he was struck down by Hodgkin's disease.

Bob, who is married and has a family of four, was forced to undergo a difficult series of cobalt treatments for his illness. Then, his career as an independent dairy farmer at an end, he began to attend the State University of New York at Delhi in order to earn an AAS degree in Agricultural Engineering.

One of the courses required for his degree happened to be a general physics course, and it was there, almost by accident, that Bob's consuming interest in the world of electronics was born. His new-found enthusiasm led him to enroll in NRI's Master Color TV Course in 1972.

Soon Bob began repairing radios and television receivers, largely for pleasure and to gain experience, and in little more than a year his pastime had burgeoned into a full-time business.

Bob's illness dealt him another blow last year, when he was forced to undergo surgery and chemotherapy, but it didn't keep him down for long.

Today, Bob is back at his old stand, the electronics shop he built in what was once the dairy barn, and enjoying his work tremendously.

Our second prize winner, Joseph M. Kelley, also discovered his talent for electronics in an unusual way. Joseph, who is 32 and a native of Weston, West Virginia, joined the Army at an early age and was stationed in Europe.

Like many of his generation, he found himself at loose ends after his discharge, and spent several years wandering the North American continent. Joseph worked variously as a car salesman, bartender, factory worker, deep-sea diver's helper, and construction worker, but without finding anything really satisfactory or likely to lend direction or stability to his life.

Almost inevitably, perhaps, Joseph eventually found himself serving a sentence in the Huttonsville (West Virginia) Correctional Center. And there, strangely enough, he discovered his aptitude for an enduring career in electronics.

At the Center, Joseph acquired over 1000 hours training in electricity, radio, and electronics, maintaining an A average throughout. He enrolled in the NRI Color TV Course, completing most of it in ten months, also maintaining an A average. In addition, he helped service the Center's TV system and various types of electronic equipment for his fellow inmates.

On the basis of his outstanding work at the Center and in his NRI course, Joseph is presently on a work-release program in Grafton, West Virginia, and plans to purchase a television servicing

business upon his final release.

Our third prize winner is Richard R. Porter, Jr. of Whitesboro, New York. Richard, presently a high school senior, found his interest in electronics at an early age, purchasing his first electronic kit when he was twelve.

Richard enrolled with NRI when he was sixteen, and plans to use his NRI training to help him work his way through college (either Rensselaer Polytech or Clarkson Tech) by servicing TV receivers and stereos.

We here at NRI are most pleased to offer our congratulations to all of our 1976 Gernsback Award winners, and are glad that NRI could play a small part in helping them find their rewarding careers in the fascinating world of electronics.

More About Servicing Record Changers

Edward Pierce

Top-flight NRI graduate Edward Pierce (Class of '74) of Baltimore's Audio Systems Repair has very kindly sent us the following addendum to our previous article on Servicing Record Changers (NRI Journal, May/June 1976), and we are pleased to send it along to you. Our thanks to graduate Pierce.

Two of the main reasons record changers are brought in for repairs are (1) that the unit will not reject but otherwise plays okay, and (2) the unit stops during the change cycle but otherwise plays okay. Repairs for each of these problems are quite easy, as follows:

WILL NOT REJECT

- 1 Spin the platter to be certain the unit is fully cycled.
- 2 Remove the platter. It is held on by a C-clip or O-ring around the spindle shaft.
- 3 Remove the change cycle drive gear. This large gear assembly is usually on the righthand side, near the tone arm, and is held on by one C-clip.
- 4 On the outside edge of this assembly is a two-piece trigger assembly. Each piece is held on with a C-clip. Remove

both. These pieces become seized due to lubrication failure and must be thoroughly cleaned with degreaser. Also clean the shaft which holds them on the gear.

- 5 After cleaning, apply light-weight machine oil to the shaft and re-assemble the two trippers. Oil again lightly.
- 6 Clean the shaft for the gear assembly.
- 7 Apply light grease to this shaft.
- 8 Turn the gear assembly over and lightly grease the grooved track. This drives the tone arm.
- 9 Replace the gear assembly.
- 10 Replace the platter and cycle the unit manually several times.

STOPS DURING CHANGE CYCLE

- 1 Spin the platter to be certain the unit is fully cycled.
- 2 Remove the platter.

The problem is caused by any one or a combination of the following: (1) Glazing

of the motor drive pulley, (2) hardening of the idler, (3) lubricants on the idler and motor pulley, or (4) bad motor. We will correct for (1), (2), and (3), thereby leaving (4) as default.

- 3 Using 400 or 600 grit emery, slightly roughen the motor pulley. This should be done with vertical strokes and *not* by spinning the pulley. Do each step individually. Afterward, use cleaning solvent to clean and degrease the pulley.
- 4 Using 250-400 grit emery, roughen the idler. Unless it was oil-saturated, this will also remove lubricants. It may need replacing. Use your own judgement.
- 5 Replace the platter and cycle the unit several times. A strobe disc helps to indicate slowdowns.
- 6 If the unit still does not cycle, visually check the motor during the cycle process. It probably stops. If so, it will have to be replaced with a new (or rebuilt) motor.

Ninety percent of all turntable troubles I get for repair are for one of the above two problems.



Thanks to you, I still have a home.

For over 30 years, Smokey has been asking you to be careful with fire.

During that time, you've helped cut the number of careless fires in half.

So from Smokey Bear and all of us who live in the forest, thanks for listening. And keep up the good work.



Ad
Council

A Public Service of This Magazine
& The Advertising Council

More Adventures in TV Servicing

J.B. Straughn

PANASONIC MODEL TR-519

This all-transistor black-and-white receiver came in with the complaint that it would only receive one station, Channel 12 from Montgomery, considered to be a strong local.

I confirmed the complaint, noting that the set had both an rf and i-f (or regular) agc adjustment. I tried turning both through their range, but with no effect. I decided that there was probably a defect in the vhf tuner and proceeded to prove this to my satisfaction by using my substitute vhf tuner, which brought the set alive and permitted reception of the usual uhf stations in this vicinity with the set uhf tuner plugged into my substitute tuner.

I removed the vhf tuner and sent it to the United Tuner Repair Company in Atlanta (this is where I got my substitute tuner) for repair. It came back with a bill including two transistors. Obviously if both transistors in the tuner were at fault,

this was the reason why only one station was received.

With the overhauled tuner installed, I fired up the set and got only Channel 12. I sent the tuner back with a nasty note and it came back with the observation that the tuner was okay and to adjust the rf agc to 2.5 volts. I now felt that a schematic was required so I got a Sams manual, located the tuner rf agc source (see Figure 1), and measured it. I obtained a reading of 11.25 volts, which of course was the reason for only one station coming in.

I then measured the base, emitter, and collector voltages. The base and emitter were okay except that they were reversed from the schematic. I figured that the schematic must be at fault and that the base should be lower than the emitter. The collector was just about the same as the emitter voltage.

The next time I visited the wholesaler I got a replacement for the rf agc transistor, although I felt the trouble might

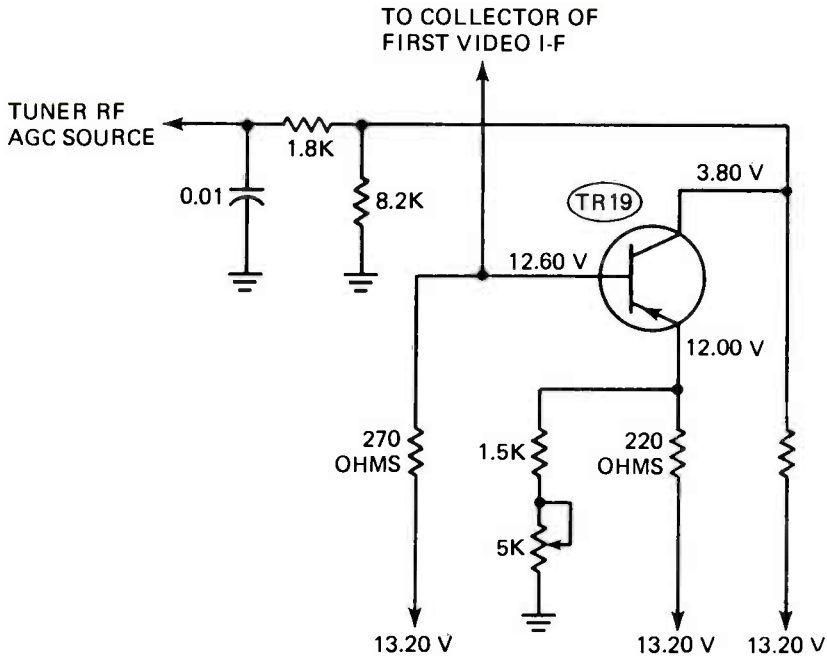

FIGURE 1. RF AGC CIRCUIT CONTROLLED BY THE REGULAR AGC ACTING THROUGH THE FIRST VIDEO I-F AMPLIFIER TRANSISTOR.

be due to a rosin joint at the collector. It looked like it.

When I got ready to install the new transistor, I grasped it with two fingers and proceeded to heat the leads and work them out of the printed circuit board. There was a resistor next to the transistor which had not cooled off and burned my fingers, so I stopped for the time being.

The leads had been heated enough to burn out most of the rosin so I fired the set up. Lo and behold, it now had plenty of sensitivity and would pick up as expected, including uhf. The collector was now down to 4 volts. While measuring at this point, the voltage suddenly jumped up to 11.25 volts and the sensitivity was lost.

By messing around, I found that if the collector was momentarily grounded the trouble would disappear. I went over the joints again and the set played for several hours before acting up again.

This was too much, so I let the set cool off and completed removal of the transistor and installation of its replacement. I had no more trouble and charged the customer \$31.

I guess the transistors in the tuner were on the shaky side or they would not have been replaced. My trusty substitute tuner let me down for once because it does not use agc and it would be impractical to take an agc voltage from the TV receiver. I knew about this, but think I would follow the same procedure and not make a habit of taking rf agc measurements. This may be because I don't get too many all-transistor sets for repairs. In tube receivers, separate agc systems are not used for front-end (rf) agc and i-f agc. The voltages are different but originate from a single source.

I will admit that after finishing up with the receiver I felt that I should have stayed in bed that day!

BRADFORD (MODEL NUMBER UNKNOWN)

This is an ancient 23-inch black-and-white receiver using a wired chassis instead of a printed circuit board. The set was dead when received. I quickly found that there was a surge resistor in series with the low-voltage diode which was open. I tacked in a 5.7-ohm replacement using clip leads.

The set would now come on but all that appeared was a horizontal line. A look at the tube lineup on the back cover showed that the vertical sweep consisted of a 6FQ7 and a 12W6, the latter being the vertical power output. The 12W6 tested weak and the 6FQ7 was dead. I had never heard of a 12W6 but I had a 6FQ7 in stock.

With the 6FQ7 replaced, the vertical sweep appeared but the raster was compressed both vertically and horizontally. The horizontal output tube was a 12DQ6, which I did not have in stock. When I went to town on Saturday I bought a 12DQ6 and a pair of 6FQ7s. Neither of the two wholesalers had a 12W6 or a substitute.

The following week I had occasion to go to town and to my surprise was able to pick up the 12W6 from the remaining wholesaler. I also got a new damper tube, since the original was weak. With the new tubes installed the raster was properly filled up, and I could see that the customer had operated the set for some time with the vertical not working because there was a horizontal line burned on the picture tube face.

The picture wasn't too bad and when the customer came by on Sunday morning he said he didn't mind the burn. I told him to come back later, as I hadn't finished soldering the surge resistor in place. I could have done this in a few minutes, but I wanted time to thoroughly check the receiver out.

I was lucky because the vertical would

not hold and the picture would roll after the set warmed up. I had no diagram of the set and if it had used a printed circuit I might have turned down the repair. However, all parts were visible from the bottom of the chassis and it was easy to see the socket terminal connections.

I started disconnecting capacitors one at a time and checking them with my ohmmeter. They were all okay except for one plastic-encased unit. The value was not stamped on the case, just a color code as follows: orange, orange, red, white, yellow. I knew the orange, orange, red meant 3300 but did not think this was a 0.0033- μf capacitor because when checking the old unit with the ohmmeter the initial charging current was considerably greater than that of a marked 3300 (0.0033) I had in stock.

What to do? I didn't want to start putting in different sized capacitors in the hope of hitting the right value. I went to my stock of Sams manuals and looked over the Bradford group to see if I could come up with a set using a 6FQ7 as part of the vertical sweep. I was lucky as I found a model BWGE-56721A using an 8FQ7 in this circuit. The only difference between the 6FQ7 and 8FQ7 is in the filament voltage and current. The set also used a 10CW5 as the vertical output instead of a 12W6.

The circuit is shown in Figure 2. The capacitor in question is C36, shown as having a value of 0.0047 μf . I had a 0.0047- μf capacitor, and when checking it with my ohmmeter I found it has about the same initial charging current as the orange, orange, red unit. (I just have plain forgotten how to read this capacitor color code!)

I checked out the circuit and found it just about identical with the schematic with the omission of C34. I had one with a working voltage of 1.6 kv, so I inserted it in the circuit along with the 0.0047- μf unit, soldered the surge resistor in place, and put the chassis back in the cabinet.

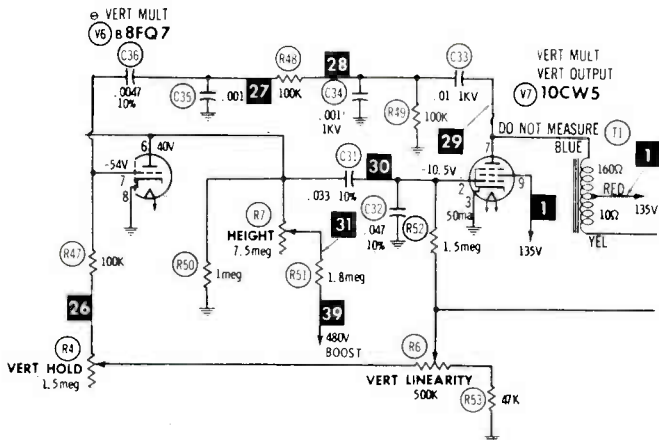

Courtesy Howard W. Sams

FIGURE 2. VERTICAL CIRCUIT OF BWGE-56721A.

After messing around with the linearity and size controls I was able to get a good raster which the hold control would make roll either up or down, and would lock in place. As a matter of fact, I was real pleased with the set. I charged the customer \$28.90 for the job and he was satisfied.

I could have done a much faster job if I had been able to read the color code of that capacitor, or if I had had a capacitor tester to measure the value of the old unit.

RCA COLOR SET CHASSIS CTC 24A

I was not at home when this set came in but my wife had written on the tag that there was no sound or picture. The back was off the set and the cheater cord had been taken off the back cover. It was apparent someone had been inside. For this reason I decided to check all tubes before starting work. I noted that a couple of tubes were missing, the video output and horizontal output tubes. Also, someone had substituted another tube for the 3A3 high-voltage tube.

It was a good thing I decided to check

all tubes, because out of the 21 tubes, including the missing ones, a total of 15 new tubes were needed. Since they came to \$92.95, I called the customer before going further and explained that these tubes would have to be installed before I could see if there was anything else wrong with the set.

I asked her what shop had been working on the set before I got it and she said that it had not been in a shop but that a local serviceman had "looked" at it. No, she hadn't been present when the looking took place. She said the set had been playing and showing color with a fair picture before it went dead.

Since there were six 6GH8 tubes showing cathode-to-heater leakage, I didn't see how this was possible, but I didn't say anything. The 6GH8 tubes are used in the color system and if the 6GH8 chroma reference oscillator had cathode (pin 7 or pin 8) to heater leakage there would have been no color.

I went to the wholesaler and bought a flock of tubes because I did not have all those required in stock. I put them in the set and fired it up. It had sound but no raster. My neon bulb on the end of the fiber rod lit up half-heartedly when

brought near the top cap lead of the 6JE6 horizontal output tube but did not give the bright glow which would have been normal. With the set on, I was able to measure the screen and grid drive voltages on the 6JE6 and found -45 volts on the grid (pin 2), which was close enough.

There was only 120 volts on the screen where the diagram called for 145 volts. This meant that the tube was drawing excess screen current. The tube envelope did not seem to get too hot so the plate current was not excessive. In most cases excessive plate current (due, for example, to shorted turns in the flyback transformer) will cause the tube to get red hot (you can see it) in short order. With normal drive, screen voltage, and no overheating, this to me indicated trouble in the boost voltage.

The thing that first came in mind was the boost rectifier because there it was on the schematic. To do any checking here I had to remove the chassis because all parts in the boost circuit were on the bottom of the chassis. Since all chassis bolts were missing (they had not been put back after prior removal) the job was easy.

I disconnected the speaker leads, removed the yoke and convergence plugs, the high-voltage anode lead, and the picture-tube socket and started to unplug the degaussing coil. The degaussing coil plug was not there, although its socket was in the side of the chassis.

I looked for the coil and found to my dismay that the shield for the picture tube, under which the degaussing coil is held, was also missing! I called the owner and asked her to check back with the former serviceman to see what had happened. This guy disclaimed all knowledge of the shield or coil. I told the customer I would try and see if the set would work without the shield and coil and if necessary would try and get a used one—new ones are not available as far as I know.

None of this would have anything to

do with lack of a raster, so I went ahead and removed the knobs and loosened the three screws holding the tuner panel to the front of the cabinet. This lets you slide the bracket up and then pull the tuner and bracket out of the cabinet. The shield of the tuner is made so it can be bolted to the rear chassis wall, enabling you to take the chassis and tuner out as one piece. I did this, and after removing the cabinet and picture tube I set the chassis on end on my work desk.

I quickly located the boost rectifier. It checked okay with my ohmmeter, but this test has little value with a high-voltage diode when the ohmmeter voltage source is only 1.5 volts. If in doubt you must try another diode. I was not in any doubt as a new diode would cost me around \$12! I at once decided the trouble must be elsewhere.

I started making some point-to-point resistance checks with the Sams manual. I soon found that the resistance from the cathode, pin 9 of the damper, to the chassis was about 40,000 ohms instead of the 2.9 megohms called for (see Figure 3). While I was at the tube socket I found the resistance from the plate, pin 2 or 7 (they tie together), to the chassis was the same. Then I measured the resistance from the plate to cathode of the damper and found it to be about 15 ohms, which of course was all the way out of the ball park.

I visually traced everything around on the schematic to see what could have broken down. After some false starts I came to C92 and C93. C92 was easier to get at so I removed it from the circuit. It checked a dead short with the ohmmeter. I had another 0.022- μ f 600-volt capacitor so I installed it.

After getting the cabinet and picture tube up on my desk, which is too small, I put the chassis in the cabinet and then discovered a dangling lead coming from the bracket holding the tuners and controls. This must have pulled loose when I

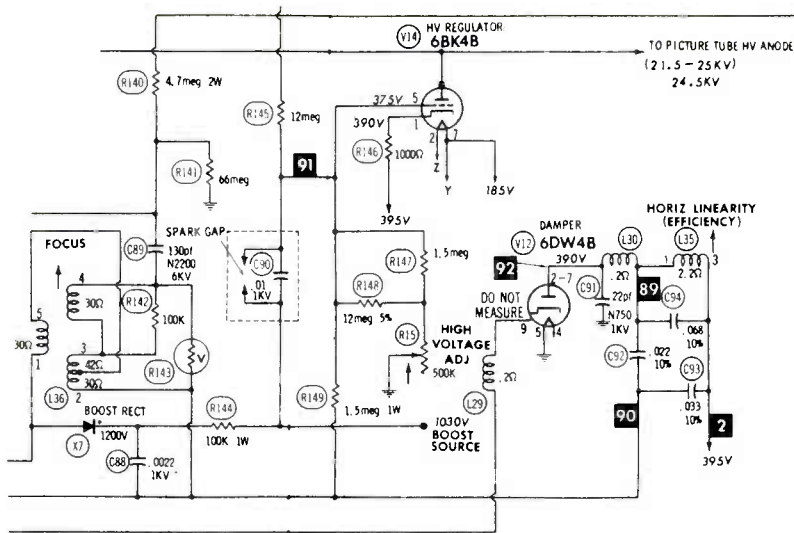

Courtesy Howard W. Sams

FIGURE 3. DAMPER CIRCUIT OF CTC24A.

was handling the tuner bracket. It was easy to see that the lead went to the horizontal hold control and from the schematic (not shown) that it went to pin 3 of the 6FQ7 horizontal oscillator tube.

I removed the chassis again and since it was too hard to lift the cabinet down and then up again I put a towel on top of the cabinet and the chassis on the towel. I had to remove a shield to get at pin 3 of the 6FQ7, where I resoldered the loose lead.

I looked into the cabinet and shook my head about the missing picture tube shield, and wondered again if the set would work without the shield in place. We will never know because I was too lazy to put the chassis back in the cabinet and then take it out again.

I figured the purpose of the shield was to hold the degaussing coil in place and ground the conductive coating on the rear of the picture tube. I knew the set would work without the degaussing coil, but didn't think the reception would be good with the ground missing. There was too much chance of arcing from the coating

to the metal cabinet.

Therefore, I made a spiral of bare wire and taped it to the aquadag coating. I fastened the other end of this bare wire under a screw holding the tube to the front of the cabinet. I installed the chassis in the cabinet and hooked everything up and fired up the set. The raster appeared along with a fine picture and sound!

I still wonder what would have happened if the aquadag was not grounded. You and I will never know for sure.

ADMIRAL CHASSIS 15K1673-33

This set came in with the complaint that it would not come on. The customer thought it was a bad line cord. I took the back off the set and checked out the line cord with my ohmmeter before he left, but the cord was okay.

I then looked the set over and found a plug-in fuse which tested open. I didn't have one on hand so I checked all the tubes in the set and came up with a cost of \$50 for tubes—the audio second de-

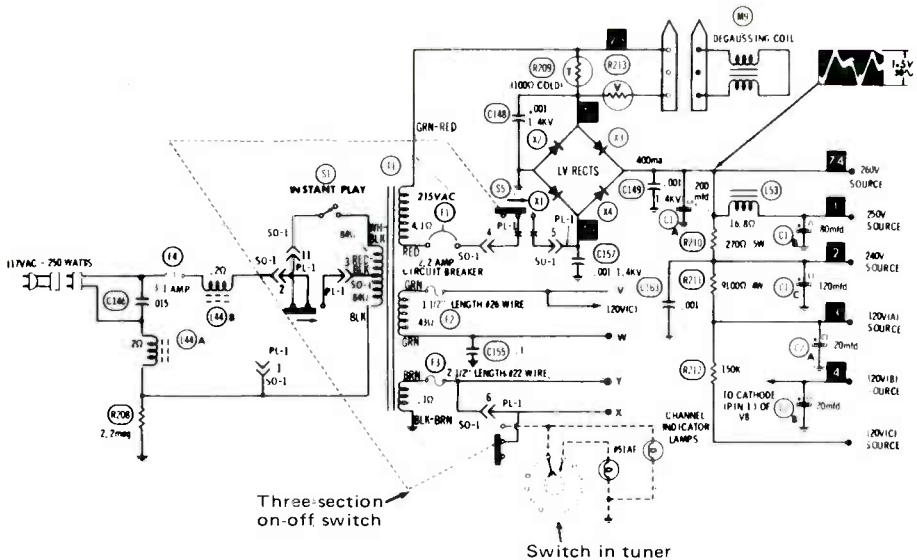

Courtesy Howard W. Sams

FIGURE 4. NOTE THE THREE-SECTION ON-OFF SWITCH. WITH THE INSTANT-PLAY SWITCH CLOSED AND THE PILOT LAMP ON-OFF SWITCH SHORTED, THE PILOT LAMPS STAY LIT WITH THE SET TURNED OFF.

tector output tube lists for \$12! I got a new fuse (I bought two on a hunch) and when installed the fuse proceeded to show a bright red glow when the set was turned on and burned out at once.

I pulled the chassis and found the thermistor (R209) in the degaussing circuit had blown up (come apart) with a portion lying on one of the bridge rectifiers (X3) and shorting it (see Figure 4). I removed the short and connected a clip lead across the ruined thermistor to complete the circuit with the degaussing coil unplugged. I fired up the set and the fuse did not blow. In fact, I got a fair color picture on rabbit ears.

I noted that the pilot lamps did not light so I pulled the tuner and installed new lamps. I put the tuner back in the cabinet and the pilot lamps still did not light! I then tested the old lamps and found one okay and the other burned out.

At this time I got out the schematic and noted that a section of the on-off

switch also controls the pilot lamps. With an ac voltmeter, I found that there was 6.3 volts ac on one side of the switch but not on the side feeding the pilot lamps. I used another clip lead to short this section of the switch and proceeded to burn out my last F4 fuse.

It seems that one of the alligator clip leads was not only connected to a switch contact but was also in contact with the chassis, shorting the power transformer filament winding. No damage to the transformer occurred because of the F4 fuse.

I replaced this plug-in fuse with a regular 3-ampere fuse having leads to fit into the plug-in fuse socket holes, which I twisted around the lugs on the burned-out plug-in fuse F4. I then turned the set on, ready to shut it off at once if necessary.

Everything was okay—the pilot lamps came on and the set worked. However, the uhf lamp stayed on in all tuner selector positions. Someone had been

into the set and had changed the uhf pilot lamp lead due to a defect in the tuner switch!

I called the customer to come over and see if he wanted the tuner to be shipped

off for rebuilding and a new on-off switch and volume control installed. He was happy with the present arrangement. Due to the large tube markup, I let the set go for \$55.80.

Heart disease is the leading cause of death in:

Birmingham	Louisville	Cleveland
Anchorage	Los Angeles	Columbus
Phoenix	New Orleans	Oklahoma City
Little Rock	Augusta	Portland
San Francisco	Baltimore	Harrisburg
Chicago	Boston	Santurce
Denver	Southfield	Pawtucket
Hartford	Minneapolis	Watertown
Bismarck	Jackson	Nashville
Wilmington	Columbia	Austin
St. Petersburg	Great Falls	Salt Lake City
Atlanta	Omaha	Rutland
Honolulu	Reno	Richmond
Boise	Concord	Washington, D. C.
Springfield	Union	Seattle
Indianapolis	Albuquerque	Charleston
Des Moines	New York	Milwaukee
Topeka	Chapel Hill	Cheyenne

**In fact heart disease is the leading
cause of death in the United States.**

Give Heart Fund
American Heart Association





HAM NEWS



By Ted Beach K4MKX

By now I'm sure that all of you are aware of the latest FCC rules on amateur radio as contained in Docket 20282. The changes that become effective on July 23, 1976 are still only a portion of the sweeping docket, and I'm sure we can expect to see some more changes in the months to come.

Just in case you have *not* gotten the word on the latest changes, I will summarize them briefly here for you. Your best bet, however, is to latch on to a copy of Part 97, which is now available apart from Volume VI of the Rules for \$1.50. Order stock number 004-000-00325-0 from the Government Printing Office, Washington DC 20402. (Part 95 on CB is also available for \$1.50, Stock number 004-000-00324-1 from the same source.)

Briefly, the new rules are that Novices may now operate with a power of 250 watts, and *all* U.S. amateurs who work the novice frequencies are similarly limited to 250 watts. Technicians will be granted novice privileges. The Conditional license is abolished, and present Conditional license holders will automatically receive full standing for the class of license held. Only medical disability will qualify an applicant in the future for a

"conditional" license, the test for which is to be administered by a volunteer examiner. The one-year wait for re-applying for a Novice license is abolished. That is, if a Novice license (or any other class of license) expires, the applicant can immediately apply for a Novice license. For more information, I strongly suggest you get the most recent edition of Part 97 mentioned above.

As promised in the last column, I got out and tried a "different" antenna at our Field Day site, and I'll have to say that I was quite pleased with the results of my tests. I haven't yet put up a permanent antenna at the home QTH, but that just may be the next step.

Most of the letters I have received had expressed interest in limited space antennas, so that's where the bulk of my experimentation was directed. I didn't have a whole lot of time to prepare for this venture, and only had a few hours at the FD site for the tests, but I was quite pleased with the results I got (contacts) for the time spent. The particular antenna that I spent the most time with was a homebrew "Slinky" dipole that I threw together for a total cost of \$7. I bought four of the toy type Slinkies from the

drug store (\$1 each), some tubular twin-lead (\$2), and some brass tubing from the hobby shop (\$1). The rest of the things I had lying around the house.

As the Slinkies come from the box, their ends are bound together with a metal band. Remove the band from one end of each of the four coils to free the end. The coils are made of a type of spring steel that resists solder like the plague, so that's what the brass tubing is for—to connect the coils together and to the transmission line. You should get tubing that has an inside diameter slightly larger than the coil material. Cut a length of tubing about an inch and a half long, being careful not to close up the end when you cut it. A fine hacksaw does the neatest job. Slip the free ends of two Slinkies into the ends of the tubing and firmly crimp the tubing in several places with a pair of diagonal cutters to grip the ends of the coils.

You now have half of your antenna finished. To protect the joint from the weather, smear a liberal amount of silicone rubber over the brass tubing connector, being sure to fully seal the ends. Repeat this process with the other two coils and you're almost finished. For a center insulator I used a piece of plastic that measured 3" x 5" x 1/4". Anything that is low-loss and strong will do. I drilled four holes in the plastic as shown in Figure 1. The two coil ends pass through the small holes near the bottom edge, while the twin lead goes through the large hole near the center. The twin lead is fed from the back up to the hole, through it and down to the coils, leaving the opening in the tubular line pointing down. This will keep rain out of the line.

The twin lead is fastened to the ends of the two coils with two short sections of the brass tubing, soldering the tubing to the wire and crimping it to the coils. Again, cover the connections with silicone rubber if the antenna is to be exposed to the weather. The upper hole is

used to haul up the antenna to its operating position.

If you extend the coils fully, they will tend to sag considerably unless you give them an internal support. I used some old nylon fishing line for this, strung through the middle of the two coils. Additional line was tied to the ends of the coil to allow "field adjustment" of the length of the two halves of the antenna should it become necessary. Actually, I never got around to trying this out, but I believe for the finest tuning of the system this could be done.

The whole thing was hauled to an altitude of about 35 feet at the center and, due to the placement of the two end supports, one end of the antenna was at about 30 feet and the other about 20 feet—a sad-looking array. I hauled on the two end lines until the two coils looked about the same length. To my eye they looked to be about eight or nine feet each, but who cares?

Next the Slinky Monster was connected to my homebrew transmission-line

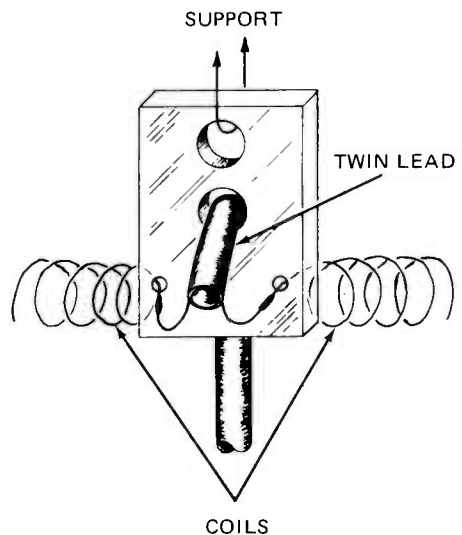

FIGURE 1. CENTER SUPPORT ASSEMBLY.

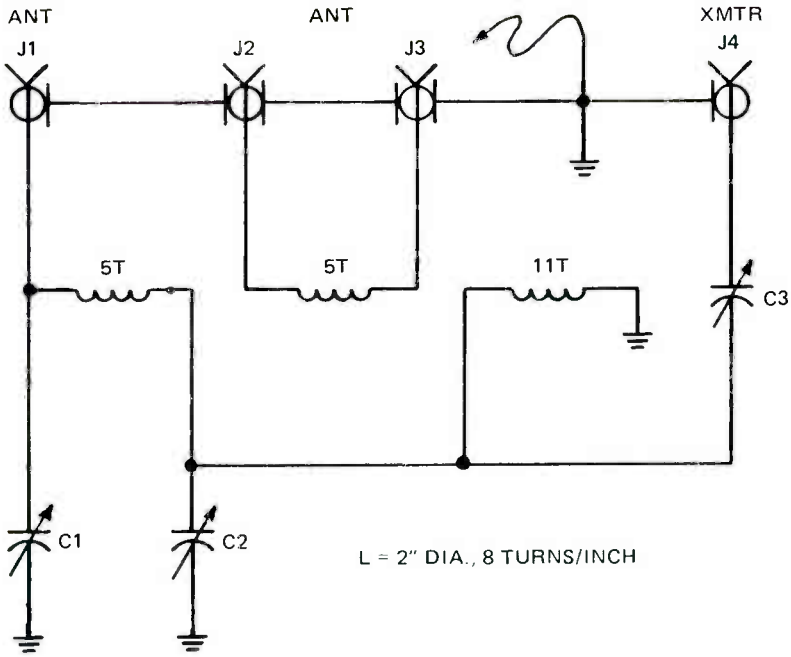

FIGURE 2. ORIGINAL MULTIBAND COUPLER.

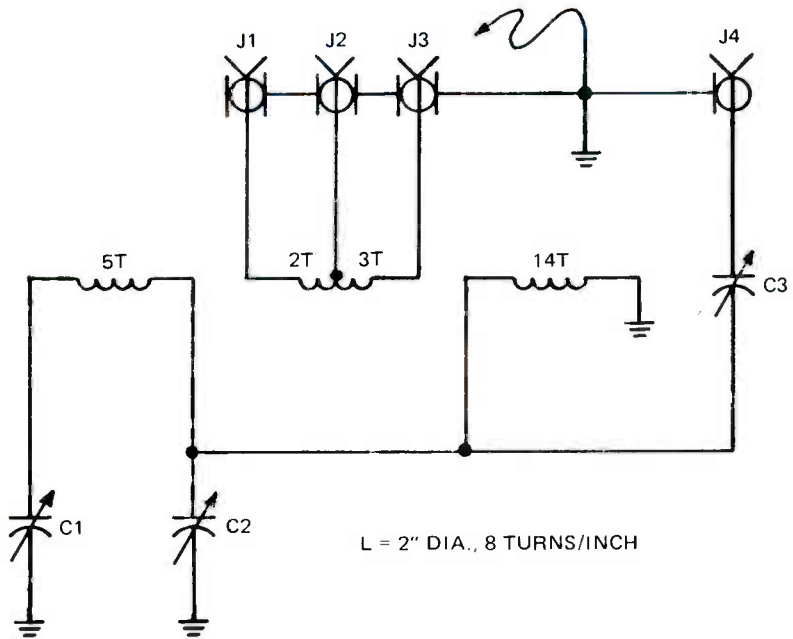

FIGURE 3. MODIFIED ANTENNA COUPLER.

coupler and we proceeded to load up on—guess what—75 meters! A few quick tweaks of the coupler controls and we had 1:1 at 3900. But was the power getting to the antenna? A quick CQ brought a reply from Georgia and New Hampshire (at the same time!) so everything looked good.

After getting through with the two stations, I dropped down to 3800 to try again. It took only a second or two to retune the coupler and once again we had 1:1 and got a rapid reply to our CQ Test. While we were at it, I thought I might as well try 80 and zoomed on down to 3525 (don't have that Extra yet!). No luck. We could approach 1:1 swr, but the coupler "ran out of capacitor range."

Rather than lengthen the antenna, we QSYed up to 3570 and once again obtained 1:1. The problem turned out to be in the coupler rather than the antenna and we have since corrected the problem as we'll explain later.

After being satisfied that the thing would work on 80 and 75, we proceeded to try out three other bands. In the time available the Friday before Field Day, we never made it up to ten meters, but were very pleased with the results on the rest of the frequencies. Since we had an inverted vee hung on the same support for 15 meters, I did try an A-B comparison on 15 sideband between my antenna and the inverted vee.

The test was not really very conclusive, because the apex of the vee was at the top of the mast (45 feet) and at right angles to the Slinky Monster. In addition, the vee was cut for the cw end of the band (no one was operating cw Friday) and it has a 2:1 swr in the phone band, so it had two strikes against it from the start. Be that as it may, we decided to use the Monster on 15 during the contest and without even trying I made over 100 contacts, so take that for what it's worth, keeping in mind I *did* sleep a while as well as operate some of the other stations.

At any rate, I was quite pleased with the antenna, and feel that it is one that can be erected in almost any space (and configuration) with only the barest care being given to its installation. You do need to tune the system, however, and I feel you should use a balanced feedline (open wire is best).

The problem I encountered with the coupler tuning the low end of 80 meters was later traced to inadequate range in the tuned circuit of the original coupler (described in detail in the September/October 1975 Journal) so I made a couple of changes to increase the utility of the coupler.

Figure 2 is the schematic of the original design, and Figure 3 shows the Mark II version. The quickest fix would be to use larger tuning capacitors, but I don't happen to have anything larger than 235 pf in my junk box, although I did have some more coil stock. In addition, the J1 connection shown in Figure 2 did not prove useful except on 20 meters with my vertical at home, so instead I decided to tap the output link coil for better loading purposes. The two-turn link or three-turn link is used for 20, 15 and 10 while the whole five-turn link is used for 40 and 80. We ended up with the same number of coax connectors, and indeed the same box was used to house the coupler.

If you didn't happen to see last year's column on this coupler, all three coils are actually a single length of coil stock, (B&W 4032) with the number of turns as shown. C1, C2, and C3 are 235-pf capacitors, with C3 being totally insulated from ground. J1 through J4 are coax connectors, the antenna going to J1, J2, or J3 for unbalanced operation, with the ground plug being plugged into one of the remaining coax connectors. For balanced output, the lines plug into two of the three output coax connectors *without* using the ground plug.

I'm sorry that I didn't get to try out

Leo	K1CIJ	A	N. Chelmsford MA
John	WN2EW1	N	Park Ridge NJ
Dorsey	WN4ONR	N	Alexandria VA
Steve	WB5MFI	G	Hatfield AR
Zack	WB5QPI	A	Midwest City OK
Nat	WN6MDL	N	San Luis Obispo CA
Ralph	WN6MMM	N	Tulelake CA
Jack	WNØSXJ	N	Osawatomie KS
Al	WA3YVN	A	Bowie MD
O.P.	WB5SKI	T	Ft. Worth TX

any other antenna systems, but perhaps I'll be able to do so in the near future. In the meantime, if any of you have any "pet" systems that might be of interest to our readers, by all means let us hear from you.

Now let's see who we have heard from since last time. As usual, those listed first are students and graduates of the Amateur Course, and those listed last are students and graduates of other NRI courses. We don't have too many this time, and also not much room left in the column to report on them, so maybe next time there will be more news from our Ham readers.

K1CIJ was a Navy radio operator during World War Two and vowed he would never study cw again after all those FOX skeds, but now he's back on the road to 35 per so he can upgrade to Extra. Fine business, Leo, and we'll all be pulling for you. I can't give you a frequency for a sked, because my operating time is so erratic. Generally if I'm on at night it will be on 40 meters around 7200 sideband or somewhere in the Novice band on cw.

WN4ONR writes that he is using a Heath HW16 on 80 meters and is in the market for a vfo. I can still remember looking forward to General just so I could use more power and a vfo, but so far I have never exceeded the new Novice limit (250 watts). What else is there to look

forward to?

I was not aware that there was a Miami in Kansas, but WNØSXJ writes that he is a member of the Miami County Amateur Radio Club (newly formed) that has two extras, three advanceds, two technicians, five novices, five generals and six waiting for various licenses. Jack is itching to go for General himself, and in the meantime works at it on 80 through 10 with a HW16/HG10 and a 14AVQ vertical with an 80-meter loading coil. Very good, Jack, and do let us know when you get that new ticket.

If WA3YVN's call sounds familiar it may be that you saw it on the cover of April 1976 *CQ* magazine. Al had a fine business article entitled "DXing from Deception Island" in that issue. He is a graduate of NRI's Servicing course, and we're happy to hear from you, Al.

WB5SKI writes that he is presently teaching theory at a local Fort Worth club but still finds time to work on a Prog. Line rig and operate his Galaxy FM210. Now if he can only find a little time to study his lessons. . .

Well, that's about it this time. The next issue will be our last for 1976. I do hope this has been a good Bicentennial year for all of you, and we'll be looking forward to hearing from you all. Until then, have fun and we'll BCNU. Very 73,

Ted - K4MKX

NRI HONORS PROGRAM AWARDS

For outstanding grades throughout their NRI courses of study, the following May and June graduates were given Certificates of Distinction with their NRI Electronics Diplomas.

WITH HIGHEST HONORS

William H. Dodd, Hopewell VA
Gordon K. Dunsmore, Jr., State College PA
Laurence Fleisher, Tulsa OK
Ollie F. Hickman, Villa Park IL
Anthony S. Kerkan, Pittsburgh PA
L. E. Kniffin, Wilmington DE
Raymond W. F. Peddie, Edmonton AB Canada
James M. Rager, San Diego CA
Sidney Shelley, Orlando FL

WITH HIGH HONORS

David Lee Alexander, Albuquerque NM
Richard R. Barbour, Dallas TX
Barry B. Becker, APO New York
Robert E. Bennett, Miami FL
Paul E. Bowden, Jr., Bethpage, NY
Russell C. Burnham, North Little Rock AR
Larry W. Burrup, Blackfoot ID
Guy W. Campbell, Jacksonville FL
Allan Carroll, Iroquois Falls ON Canada
Herbert Q. C. Chang, Jr., Hilo HI
Richard H. Chase, Altus AFB OK
John Joseph Dobiak, Augusta GA
Willis Paul Duhon, Annapolis MD
Thomas J. Evans, Tucumcari NM
Larry M. Farley, Spanishburg WV
Robert E. Fine Doylestown PA
Stanley J. Golas, Melbourne FL
Bernard J. Grabusky, Northampton PA
Rene B. Jimenez, West New York NJ
Robert E. Jones, Ebony VA
Sushma L. Kapadia, New Brunswick NJ
Edward J. Karas, Holland PA
Donald Lobdell, Wilbraham MA
James E. Marr, Seymour Johnson AFB NC
John Louis Mayo, Satellite Beach FL
Jack C. Mc Ilvoy, San Antonio TX
Robert W. Moir, Warren ME
Ronald E. Monk, Arbovale WV
Roy C. Monzello, Northridge CA
Roy A. Mosteller, Jr., Pittsburgh PA
Joseph H. Myers, Jr., Laurel DE
James L. Nagel, West Fargo ND
Mr. Charles F. Purvis, Jr. Falls Church VA
Orville E. Restad, Seattle WA
Wayne L. Riley, Goldsboro NC
Richard N. Rittmeister, EWA Beach HI
Helmut Saarts, Putnam Valley NY
Larry D. Schulenberg, Council Bluffs IA

Jose Freitas Serpa, Stoughton MA
Richard Sochanski, Philadelphia PA
John E. Tullius, La Crescenta CA
Kenneth H. Vesey, Warren OH

WITH HONORS

Ed Arencibia, Maitland FL
James Attwooll, Greenlawn NY
Jerry R. Beasley, Elizabeth City NC
Robert T. Benic, Hudson OH
William G. Bennethum, Shillington PA
David O. Bode, Fairfax VA
George R. Boehl, Pittsford NY
Charles M. Boyd, Oak Ridge TN
Harold H. Brown, Jr., Dallas TX
Ki Chui Cho, Elmhurst NY
Allen Wayne Davis, Cheverly MD
Mark Des Jardins, Springfield OH
William C. Faulkner, Indianapolis IN
John M. Feeney, Manassas VA
John S. Futey, Jr., Berlin PA
Raymond E. Gladwin, Sunnyvale CA
Dan J. Goodman, Conroe TX
Stephen T. Grimes, Independence KS
James E. Gunnoe, Jr., Plantation FL
Hugo B. Haufler, Jr., Holmstead AFB FL
Richard Arvin Hauser, Virginia Beach VA
C. Kenneth Hendrick, Lexington NC
James A. Herr, Powax CA
Larry Gene Higgins, Cordova AL
David L. Hill, Thunder Bay (F) ON Canada
Louis M. Johnson, Omaha NE
George J. Karras, Burtonville MD
Edward R. Macke, Mundelein IL
Basil J. Marandola, Croydon PA
Sidney E. Olson, Caldwell ID
Emory L. Parker, Lowell OH
John H. Saari, Jacksonville FL
Nathan E. Schumacher, San Leandro CA
James G. Schrock, Jr., Tampa FL
Larry W. Seely, Lamar CO
Charles R. Sell, Fredericksburg VA
Arne Simonsen, Topswam ME
Lewis E. Skelton, Jr., Richmond VA
Eddy Smith, Burbank IL
Raymond G. Smith, Cragmoor NY
Michael R. Stricker, Biloxi MS
George L. Theis, Jacksonville FL
James R. Trick, Oromocto NB Canada
Gene M. Wampler, Dayton VA
Louis P. Yakubek, Perrysburg OH
H. B. Zachry, Midwest City OK

Popular Conar - Selected Titles from TAB BOOKS

- Hobbyist / Experimenter
- Basic Electronics
- CB Radio
- TV Troubleshooting
- Microprocessors / Microprogramming
- Aviation Electronics
- Industrial Electronics
- Electronic Music

BUILD YOUR OWN WORKING ROBOT

by David L. Heiserman. A working robot anyone can build. Following the author's concise step-by-step instructions, the robot can be built in stages, each adding more "life." All parts are readily available at any electronics store. 238 pps., 5½ x 8½ soft cover.

Order No. 841 \$5.95

INTRODUCTION TO MEDICAL ELECTRONICS—FOR ELECTRONICS & MEDICAL PERSONNEL—2nd Ed.

by Burton Klein. Updated edition of what has become the standard text for those in the bioelectronics field. 320 pp., 126 ill., 5½ x 8½ soft cover.

Order No. 830 \$7.95

IMPEDANCE

by Rufus Turner. Simplified basic text on a typically complex subject. It approaches the subject with a minimum of math and in a manner comprehensible to anyone with a basic knowledge of electricity. Explains AC fundamentals, the nature of impedance, and impedance measurements. Appendices cover conversion factors, explanation of abbreviations, phase angle data, practice exercises and answers. 196 pp., 90 illus., 5½ x 8½ soft cover.

Order No. 829 \$5.95

SWITCHING REGULATORS & POWER SUPPLIES WITH PRACTICAL INVERTERS & CONVERTERS

by Irving Gottlieb. Tells how to design and build modern regulators and converters for any size any application—to save energy, space and money. 252 pps., 128 ill., 5½ x 8½ soft cover.

Order No. 828 \$6.95

MASTER HANDBOOK OF 1001 PRACTICAL ELECTRONIC CIRCUITS

by Ken W. Sessions. A comprehensive collection of 1001 integrated-circuit and transistor circuits with all the data needed to put the circuits to work. 602 pps., 5½ x 8½ soft cover.

Order No. 800 \$9.95

CB RADIO OPERATOR'S GUIDE—2nd Ed.

by Robert Brown & Paul Dorweiler. New 2nd Edition tells the reader everything he needs to know about this fast-growing hobby. Includes complete FCC rules & regulations. 256 pps., 139 ill., 5½ x 8½ soft cover.

Order No. 799 \$5.95

MOSFET CIRCUITS GUIDEBOOK—With 100 Tested Projects

by Rufus Turner. An excellent learn-by-building text. Contains projects to suit every need, all projects use a single workhorse MOSFET. 196 pps., 104 ill., 5½ x 8½ soft cover.

Order No. 796 \$4.95

MICROELECTRONICS

by Clayton Hallmark. A thorough introduction to the extremely compact world of microelectronics for hobbyists, technicians, and students. It explains and illustrates how various microelectronics components are made, how they work, and how they are combined to form practical devices. Includes many projects and demonstrations to enable the reader to build useful circuits and develop expertise, plus a listing and description of available linear and digital ICs. 224 pps., 248 ill., 5½ x 8½ soft cover.

Order No. 794 \$5.95

BUILD-IT BOOK OF MINIATURE TEST & MEASUREMENT INSTRUMENTS

by Robert Haviland. Everyone involved with electronics will want this book which shows how to design, build and calibrate a wide variety of miniaturized measuring equipment. It gradually goes from simple to complex instruments to develop skill and measurement expertise. 238 pps., 151 ill., 5½ x 8½ soft cover.

Order No. 792 \$4.95

OP AMP CIRCUIT DESIGN & APPLICATIONS

by Joe Carr. A practical handbook on operational amplifiers offering scores of circuit applications and projects. Explains how op amps work, how circuits associated with op amps work, and provides the insight needed to design op amps for everyone from hobbyist to engineer. 280 pps., 239 ill., 5½ x 8½ soft cover.

Order No. 787 \$6.95

MICROPROCESSOR/MICROPROGRAMMING HANDBOOK

by Brice Ward. Tells what they are, how they work, where they're used, how they can be used in almost any application, and fully explains and illustrates basic microprogramming techniques. 294 pps., 5½ x 8½ soft cover.

Order No. 785 \$6.95

DIGITAL LOGIC ELECTRONICS HANDBOOK

by Bill Hunter. Teaches the newest of the new—digital electronics, plus number systems, logic, and Boolean algebra. Includes circuits for modern projects like calculators, digital clocks and thermometers, etc. 308 pps., 226 ill., 5½ x 8½ soft cover.

Order No. 774 \$6.95

TROUBLESHOOTING WITH THE DUAL-TRACE SCOPE

by Robert Goodman. A dual trace triggered-sweep oscilloscope enables a technician to actually see what is happening at two critical points in a circuit within precise time intervals. This text thoroughly explains how to put this versatile modern instrument to work. 224 pps., 5½ x 8½ soft cover.

Order No. 772 \$5.95

TV SCHEMATICS: How To Read Between The Lines

by Art Margolis. Here are valuable time- and money-saving tips that unlock the secrets hidden in TV schematics. Shows technicians and do-it-yourselfers how to really put available servicing data to work, and unravels the meaning of component symbols diagrams, charts, lists, numbers, and tests. 252 pps., 188 ill., 5½ x 8½ soft cover.

Order No. 738 \$5.95

MODERN GUIDE TO DIGITAL LOGIC: Processors, Memories and Interfaces

by United Technical Publications. A truly modern guide with up-to-date information on the most advanced digital logic circuits including Schottky TTL—high-speed ECL—high-noise-immunity logic—CMOS logic—MICROPROCESSORS—bipolar and MOS memory systems. Unique in that it illustrates how to design and interface logic and memory systems, using the latest techniques and digital ICs. 294 pps., 222 ill., 5½ x 8½ soft cover.

Order No. 709 \$6.95

DIRECTORY OF ALUMNI CHAPTERS

DETROIT CHAPTER meets at 8 p.m. on the second Friday of each month at St. Andrews Hall, 431 E. Congress St., Detroit. Chairman: James Kelley, 1140 Livernois, Detroit, Michigan. 841-4972.

FLINT (SAGINAW VALLEY) CHAPTER meets 7:30 p.m. the second Wednesday of each month at Andy's Radio and TV Shop, G-5507 S.Saginaw Rd., Flint, Michigan. Chairman: Roger D. Donaven.

NEW YORK CITY CHAPTER meets at 8:30 p.m., first Thursday of each month, at 1669 45th Street, Brooklyn, New York. Chairman: Sam Antman, 1669 45th Street, Brooklyn, New York.

NORTH JERSEY CHAPTER meets at 8 p.m. on the second Friday of each month at the Players Club, located on Washington Square in Kearny, New Jersey. Chairman: Al Mould. Telephone 991-9299 or 384-8112.

PHILADELPHIA-CAMDEN CHAPTER meets on the fourth Monday of each month at 8 p.m. at the home of Chairman Boyd A. Bingaman, 426 Crotzer Avenue, Folcroft, Penna. Telephone LU 3-7165.

PITTSBURGH CHAPTER meets at 8 p.m. on the first Thursday of each month in the basement of the U.P. Church of Verona, Pa., corner of South Ave. and Second Street. Chairman: James Wheeler.

SAN ANTONIO (ALAMO) CHAPTER meets at 7 p.m., fourth Thursday of each month, at the Alamo Heights Christian Church Scout House, 350 Primrose St., 6500 block of N. New Braunfels St. (three blocks north of Austin Hwy.), San Antonio. Chairman: Robert Bonge, 222 Amador Lane, San Antonio. All San Antonio area NRI students are always welcome. A free annual chapter membership will be given to all NRI graduates attending within three months of their graduation.

SOUTHEASTERN MASSACHUSETTS CHAPTER meets at 8 p.m. on the last Wednesday of each month at the home of Chairman Daniel DeJesus, 12 Brookview St., Fairhaven, Mass. 02719.

SPRINGFIELD (MASS.) CHAPTER meets at 7:30 p.m. on the second Saturday of each month at the shop of Norman Charest, 74 Redfern Drive, Springfield, Mass. 01109. Telephone (413) 734-2609. Chairman: Preston Atwood.

TORONTO CHAPTER meets at McGraw-Hill CEC, 330 Progress Avenue, Scarborough, Ontario, Canada. Chairman: Branko Lebar. For information contact Stewart J. Kenmuir, (416) 293-1911.



DETROIT CHAPTER ELECTS NEW OFFICERS

At the May 14 meeting, a defective transistor radio was used as the project. Mr. Kelley found the 6-volt transformer to be defective, and a substitute transformer was placed in the radio and the radio performed fine.

The Chapter welcomed Donald A. Hughes from London, Ontario. Mr. Hughes is taking an NRI course in TV Servicing.

At the June 11 meeting, Mr. Oliver and Mr. Kelley tried to solve some high-voltage problems that their guest, Mr. Kincaid, is having with his Conar TV. After some discussion it was decided that a coupling capacitor and a resistor were the culprits and Mr. Kincaid replaced same.

The Chapter held its yearly election of officers. Those elected were Mr. J. J. Kelley, Chairman; Mr. John Nagy, Vice Chairman; Mr. Earl Oliver, Treasurer; and Tom Tishler, Secretary.

Mr. Berus resigned his Secretary position due to the long illness in his immediate family.

After the meeting, members were

NRI AA OFFICERS

Ray Berus	President
Earle B. Allen, Jr.	Vice President
J. S. Bartlett	Vice President
Homer Chaney	Vice President
Branko Lebar	Vice President
Tom Nolan	Executive Secretary

Alumni News

treated to refreshments provided by Mr. Oliver.

All students in the Detroit area are welcome to attend our meetings, which will begin again in September.

SAGINAW VALLEY CHAPTER CELEBRATES BIRTHDAY

At the May 12 meeting, Douglas Gram demonstrated the use of the B&K Analyst to locate lost color in a Montgomery Ward color set which had an intermittent color problem. After checking a few capacitors and replacing the color killer transistor and the bandpass amplifier transistor, it all turned out to be a burst amplifier transistor which would not pass the color.

At this meeting a new member was ushered into the Chapter, Chester Mazur. He is just starting the NRI course, and comes from Saginaw, 55 miles from Flint. Welcome, Chester, and we are glad to be of any assistance when you need help.

At the May 26 meeting, there was a double celebration held because Andrew Jobbagy had his birthday and also celebrated his 45th year since graduating from the NRI Radio and TV course. The

members all had lunch and cocktails. The meeting was the last before closing for the summer vacation. However, Mr. Jobbagy will have a get-together every two weeks for the new students who need any help with their lessons and experimental work.

Cash Laferty brought in a problem involving a 35C5 audio output amplifier running hot on a TV set. Members solved the problem in short order.

On June 8, the Chapter held their first summer meeting for the new students from NRI. Mr. Jobbagy dug up a 1958 edition of the NRI Journal, which explained all about Ohm's law as used in service work. The students were very interested in learning the simple explanations which were in the article written by a Mr. Dale Stafford in the NRI News.

At the next meeting, Steve Avetta and Fred Malik will be taking over as Consultants to the students.

SPRINGFIELD CHAPTER RECESSED FOR SUMMER

The Springfield Chapter held its Annual Picnic at the home of John Parks in Ware, Massachusetts, on June 26.

John's home was an ideal setting with a swimming pool, a park nearby, and the weather was ideal. The members cooked steak while the wives assembled all of the other good foods.

Many members enjoyed the swimming pool, and also baseball and tennis. Norm Charest was struck out three times by Al Dorman's wife, Elenora; Norm and John Parks played tennis against Al and Elenora. None of them will likely be asked to go to Wimbledon but they had lots of fun and exercise.

After the evening meal, everyone went into Joanne's and John's home to see the slides from their recent trip to Europe.

A very enjoyable day was had by the members and their wives. Our meetings will resume in September.

NEW YORK CHAPTER STILL GOING STRONG

Back in the beginning of the year, Michael Nelson, an NRI student, brought in a Conar multimeter which was having difficulty in dc calibration. None of the members present was familiar with this type of meter so the best we could do was advise him on the parts to check. We also worked on Mr. Bristol's 600 Conar TV. We did a lot of resoldering, which seemed to take care of the problem.

At our April meeting, our guest, Steve Pukatch, brought in a digital voltmeter, asking us to check it out because he was unfamiliar with it. We told him we were also, but we experimented with it and it seemed to be a very accurate instrument. Mr. Vincent Melomo, also a guest, brought in a Conar multimeter claiming no meter action at all. Our transistor expert, Steve Kross, found that two of the transistors were defective. These have since been replaced by NRI and the meter works fine. At the end of the meeting, Vincent joined our Chapter. We then had a social with coffee, tea, cake and soda.

At the May 6 meeting, our old stand-by, Willie Foggie, gave a demonstration

on his dual triggered scope. He showed how trouble can be spotted in no time. He then demonstrated a new instrument he bought recently. It is a coil checker. It checks yokes and flybacks in seconds. Though it was rather expensive, it has already saved him enough time for him to claim it was well worth the cost.

Vincent Melomo brought in a Panasonic portable TV which he had undertaken to repair, although he is a novice at electronics. He had a raster but no sound or picture. He had already replaced all tubes and had done numerous checks on voltages and resistors, but with no success. Willie Foggie proceeded to do some checking and it did not take him long before he found that the AVC tube circuit was defective. Upon probing in that circuit, he found that the AVC pot in the grid circuit was defective. By pushing on the pot, the picture and sound instantly came on.

Mr. Angelo De Francesco was a guest at this meeting and joined the Chapter after spending the evening with us. We then had our usual social of coffee, cake and soda.

... AND IT'S TIME FOR THE 1977 NRIAA NOMINATIONS ...

Another year has gone by and we are now ready to elect officers for 1977. We will nominate one candidate for President and four candidates for Vice President. These nominations must be received at NRI by October 15, 1976. The nominees will be announced in the next issue of the Journal.

In considering whom to nominate, members should keep in mind the restriction on the reelection of incumbent and past officers as set forth in Article 6, Section 2 of the constitution quoted below:

The President shall not be eligible for reelection until after expiration of at least eight years following his last term of office and further may be a

candidate for Vice President only after expiration of at least one year following his term of office as President. Vice Presidents may not serve more than two consecutive terms; when reelected for a second consecutive term they shall not thereafter be candidates for Vice President until after expiration of at least three years following their second term of office.

In past years we have made suggestions as to possible candidates for office. This year, however, we are going to leave it entirely up to you, and if you yourself feel qualified you are welcome to nominate yourself for any of the positions.

Below you will find a 1977 nomination ballot and you will notice that the polls close October 15, 1976.

Thomas F. Nolan
Executive Secretary
NRI Alumni Association
3939 Wisconsin Avenue
Washington, D.C. 20016

1977 NOMINATION BALLOT
(Polls Close October 15)

I am submitting this nomination ballot for my choice of candidates for the coming election. The persons below are those whom I would like to see elected officers for 1976.

My choice for President is _____

City _____ State _____

My choices for four Vice Presidents are

1 _____ City _____ State _____

2 _____ City _____ State _____

3 _____ City _____ State _____

4 _____ City _____ State _____

Your signature _____

Your student number _____

Your address _____

Solid-State EIGHT-BAND Portable Radio with Squelch Control



Stock No. EN409

**SOLID-STATE AC/DC FM/AM/MARINE/CITIZEN/AIR/SHORTWAVE/PSB₁/PSB₂
EIGHT-BAND PORTABLE RADIO**

Features squelch control to eliminate background noise and undesirable hiss on police, uhf and fm bands. AGC (automatic gain control) and AFC (automatic frequency control) with on-off switch ensures drift-free reception. Big 4-3/4-inch permanent dynamic speaker ensures powerful dynamic sound reproduction. Large battery/tuning indicator functions as a battery meter and tuning

meter. Fine tuning control for pinpoint precise tuning. Sensitive reception with large-scale ferrite bar antenna and rotary telescopic antenna. Band indicator on front instantly shows band you have selected. Pushbutton switch lets you illuminate dial area only when you need it. A compact 12 1/4 inches wide by 9 1/4 inches high by 5 1/2 inches deep. Operates on ac or four C-cells.

Only **\$99⁹⁵**

Plus \$2.50 postage and handling

CONAR

A Division of the National Radio Institute
3939 Wisconsin Avenue
Washington, D.C. 20016

CHECK ONE:

- Cash order
 COD (20% deposit required)
 Select-A-Plan order

CHECK ONE:

- New Conar account
 Add-on Conar account
 Reopen Conar account

PLEASE PRINT

NRI Student or Graduate No. _____

Name _____

Address _____

City _____ State _____ Zip code _____

Social Security No. _____

Ship to another address? Give directions here:

Name _____

Address _____

City _____ State _____ Zip Code _____

c/o _____

Moved since last order?

Previous address _____ City _____ State _____ Zip code _____

1.	Name of Item	2.	Stock No.	3.	How Many?	4.	Price Each	5.	Total	Wt.

IMPORTANT:

To speed handling, any correspondence should be on separate paper.
 All prices are net FOB, Washington, D.C.
 Please include postage for weight shown and insurance on Parcel Post orders.
 A 20% deposit is required on COD orders. Select-A-Plan orders: Please complete reverse side and sign payment agreement below. Thank you for your order.

- 6. Total cash price for merchandise
- 7. Parcel Post and insurance (Do not remit for items shipped Express Collect)
- 8. 10% cash down payment and Parcel Post costs required on new Conar accounts.
- 9. Unpaid balance of cash price (Items 6 and 7 less item 8)
- 10. Sales tax (Washington, D.C. residents only)
- 11. Unpaid balance (Amount to be financed) (Item 9 plus item 10)

Prices in the Conar catalog and Select-A-Plan time payment privileges apply only to residents of the United States and Canada. Residents of Canada and foreign countries are responsible for customs charges.

PAYMENT AGREEMENT

Enclosed is a down payment of \$ _____ on the merchandise I have listed on the Conar Order Form. I will pay Conar a minimum payment of 7% of the beginning unpaid balance or \$5 per month, whichever is greater, until the full balance plus applicable interest is paid. Title to and right of possession of the merchandise shall remain in Conar Instruments until all payments have been made. If I do not make the payments as agreed, Conar may declare the entire balance immediately due and payable. In satisfaction of the balance, Conar may, at its option, take back the merchandise, which I agree to return upon request. I agree that the above conditions shall apply to any add-on purchases to my account. The statements on my credit application are true and are made for the purpose of receiving credit.

Date _____ Buyer sign here _____

Please do not write in this space.

RETAIL INSTALLMENT CONTRACT AND SECURITY AGREEMENT

CONAR SELECT-A-PLAN SELECT YOUR TERMS TO FIT YOUR BUDGET

CDNAR FINANCIAL RATES

The Finance Charge on balances up to \$500 is 1½% per month. On any portion of a balance over \$500, the rate is 1% per month. This is an Annual Rate of 18% and 12% respectively. The Finance Charge is computed on the month end balance of your billing cycle. You will receive a statement each month approximately 10 days before your payment is due. It will give you the current balance, finance charge, list payments made during billing cycle, date your payment is due, and amount of minimum payment due.

HOW TO DETERMINE THE AMOUNT OF YOUR MONTHLY PAYMENT

The minimum monthly payment on a Conar account is 7% of the original unpaid balance or \$5, whichever is greater. The 7% is calculated to the nearest dollar. For example, if your original balance is \$140, your payment would be \$10. If your original balance is \$160, your payment would be \$11.

And remember—every purchase carries the Conar Guarantee—"the best in the industry."

TO SPEED SHIPMENT

1. Complete other side of this sheet.
2. Insert amount of down payment (at least 10% of total order) and other information in Payment Agreement on other side.
3. Sign Payment Agreement and fill in Credit Application.

IMPORTANT: Additional purchases—Once your credit is established and you have made at least three payments on your account, you can "add on" to your account with purchases of \$20 or more. No down payment is required for add-ons of less than \$100. If you are under 21, please have the Payment Agreement and credit application filled out and signed by a person over 21. He can make the purchase for you and will be responsible for payment. If you have a Conar account open or recently paid in full, just sign the Payment Agreement.

NOTICE TO THE BUYER: (1) Do not sign this agreement before you read it or if it contains any blank space. (2) You are entitled to a copy of this agreement.

IT'S AS EASY AS **A - B - C** TO OPEN A CONAR ACCOUNT

PLEASE ALLOW ADEQUATE TIME FOR NORMAL ROUTINE CREDIT CHECK. ONCE YOUR CREDIT IS ESTABLISHED, ONLY YOUR SIGNATURE IS NEEDED TO ADD ON PURCHASES.

WHERE DO YOU LIVE?

A ➔ Print full name _____ Age _____
Home address _____ City _____ State _____ Zip code _____
Home Phone _____ How long at this address? _____ () Own home () Rent
Rent or mortgage payments \$ _____ per month () Married () Single Wife's name _____
No. dependent children _____ Previous address _____ How long? _____

WHERE DO YOU WORK?

B ➔ Your employer _____ Monthly income \$ _____
Employer's address _____
How many years on present job? _____ Position _____
Previous employer _____
Wife's employer _____ Monthly income \$ _____

WHERE DO YOU TRADE?

C ➔ Bank account with _____ () Checking
Address _____ () Savings
() Loan
Credit account with _____ Address _____
Credit account with _____ Address _____

Total of all monthly payments including car \$ _____

New! from FANON...

CB for the Young

... or for anyone who needs low-cost communication.

Spokesman I Bike/Base Station and AM Radio

Youth-styled for instant two-way communication with walkie-talkies, mobile units, and base stations in the neighborhood, at the beach, or at campsites, the Spokesman I is a combination all-channel tunable CB receiver, powerful AM radio, and channel 14 CB transmitter.

Battery-operated, completely self-contained and equipped with telescoping CB antenna and high-gain ferrite bar AM antenna, Spokesman I is the perfect way to keep in touch with friends or to listen to music, sports, and news. Included with the Spokesman I is a "quick-disconnect" handle-bar mount, and when the Spokesman I is removed from the mount there is a vinyl carrying case with shoulder strap which allows the user complete mobility.

No license is required for the operation of the Spokesman I since the unit conforms with all necessary FCC regulations for transceivers of this type. Operation of this unit has been simplified for many hours of useful radio communications and fun. Spokesman I may be used with any mobile or walkie-talkie unit operating on channel 14, as well as with identical Spokesman I units located nearby.

The Spokesman I uses one nine-volt battery (not included) for its operation.



•Two way communication on CB channel 14
•Monitors all 23 CB channels •AM radio for music, sports, and news •Built-in speaker-microphone •Crystal-controlled transmitter No license required •Vinyl carrying case for "go-anywhere" convenience. •6 $\frac{3}{4}$ " w by 3" h by 3" d •Weight 1 $\frac{1}{2}$ pounds.

Stock No. CB001

Only \$34.95

Plus \$1.50 shipping and handling

Dispatcher II CB Base Station and AM Radio

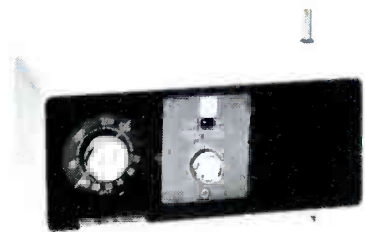

Stay in touch with walkie-talkies and mobile rigs. Listen to sports and news! Two-way communication on CB channel 14, monitor all 23! No license required. Youth-styled 100 milliwatt, press-to-talk bar, earphone, 9 v dc power jack, speaker/microphone. Uses 6 D-cells. 4 $\frac{1}{4}$ inches by 10 inches by 4 $\frac{1}{4}$ inches. 2 $\frac{1}{2}$ pounds.

Only \$33.95

Plus \$1.50 shipping and handling

Stock No. CB002

Model "Signal 10-4"

Tech-Styled Walkie-Talkies



New! from



For camping, at the beach, and around the neighborhood . . . for communication and just for fun! Fanon's youth-styled Signal 10-4 walkie-talkies feature three-way communication: CB 10-code, Morse code, and a unique large light-emitting diode for *signal* light communication (works with Morse code button). No license is required for operation since the units conform to all necessary FCC regulations. They are equipped with crystals for transmission on CB channel 14. Designed for easy operation, they feature a speaker/microphone, code key, LED signal light, official Morse code guide, volume control/on-off switch, and solid-state amplifier. They each use a 9-volt battery (not included) and are constructed of rugged, high-impact plastic.

Only \$19.95 pr.

Plus \$1.50 shipping
and handling

Stock No. CB104

●Instant three-way communication ●LED signal light ●Morse code ●Two-way voice transmission on CB channel 14 ●No license required ●Extra-long 36-inch telescoping antenna ●Superregenerative four-transistor, crystal-controlled ●5½" by 2½" by 1¾" ●One pound.

NRI Journal
3939 Wisconsin Avenue
Washington, D.C. 20016

MR LAWRENCE T ANDERSON B198-F424
3453 BALSAM NE
GRAND RAPIDS MI 49505

Second-Class
Postage Paid
at Washington, D.C.
and Additional Entry