

CB

- Servicing CB Radio
- Recent Developments in Optoelectronics



journal
May/June 1974

SAVE 50 PERCENT... OR MORE!

Our loss is your gain . . . we overbought and these 250 new, world-renowned Olivetti electric adding machines must be moved!

Original
List
~~\$79.50~~

OLIVETTI SUMMA 19

Save 50 Percent . . . **Now Only \$39.25**

Or More . . . the Olivetti is yours for **Only \$20.00**

WITH ANY CONAR ORDER TOTALLING \$150 OR MORE!

Note: Although we overbought, the supply is limited. These will go out on a first-come, first-served basis. The special price cannot be retroactive or apply to previous \$150 orders. The order MUST be received on the NRI Journal order blank.

Note: Please add \$3.00
for shipping and handling

Stock No.19TO



Order form
in back of
Journal

Plan household budgets, check statements, finish office work at home, itemize purchases, figure expenses easily and accurately. Breeze through tax reports, grocery bills, balance checkbooks, and solve your children's homework. The Olivetti Summa 19 is no larger than a sheet of regular typing paper, weighs under 8 pounds, yet offers all the important features, speed and touch-operation usually found only in higher-priced machines. Its low, slim silhouette permits unique portability from desk to desk, city to city, or office to home. A complete adding-figuring machine, the Summa 19 is at home with office work. It adds (of course), subtracts, multiplies and prints entries and answers on tape in large, clear figures for permanent reference.

FEATURES:

- Standard 10-key electric keyboard
- 7 digit listing
- 8 digit totaling capacity (999,999.99)
- Direct subtraction
- Calculates at 200 cycles per minute
- Clearing, non-add and repeat keys
- Column indicator
- Multiplication by repeat addition



journal

May/June 1974
Volume 32, No.3



<i>Phillip D. Deem</i>	2	SERVICING CB RADIO
<i>Harold J. Turner, Jr.</i>	12	RECENT DEVELOPMENTS IN OPTOELECTRONICS
<i>Ted Beach</i>	18	HAM NEWS
	22	NRI HONORS PROGRAM AWARDS
<i>Tom Nolan</i>	26	ALUMNI NEWS

EDITOR AND PUBLISHER

William F. Dunn

MANAGING EDITOR

Tom Beadling

EDITORIAL ASSISTANT

Mildred Duncan

STAFF ARTISTS

Bill Massey

Arthur Susser

Ernie Blaine

In this issue,
Phil Deem presents a
concise survey of the CB radio
field and troubleshooting techniques.
Also, Joe Turner discusses the
present state of the art in
the relatively exotic field
of optoelectronics.

The NRI Journal is published bimonthly by the National Radio Institute, a division of the McGraw-Hill Continuing Education Center, 3939 Wisconsin Avenue, Washington, D.C. 20016. The subscription price is two dollars yearly or 35 cents per single copy. Second-class postage is paid at Washington, D.C.

SERVICING CB RADIO

Phillip D. Deem

The next time you're on the road, take a little closer look at the other vehicles around you. The chances are good that you will spot several that have one or more antennas in addition to the one mounted up front for the broadcast band radio. You can be pretty certain that the driver of the car has decided to enjoy the convenience of Citizens Band radio. He has joined a group of nearly one million other licensees who use Citizens Band (CB) radio for personal or business communications.

The Class D Citizens Band was established in September of 1958 by the Federal Communications Commission. The band consists of 23 channels beginning at 26.965 MHz and ending at 27.255 MHz. A typical CB radio is shown in Figure 1. It is the Courier "Classic II."



FIGURE 1. COURIER "CLASSIC II" 23-CHANNEL MOBILE/BASE RIG WITH BUILT-IN AC SUPPLY.

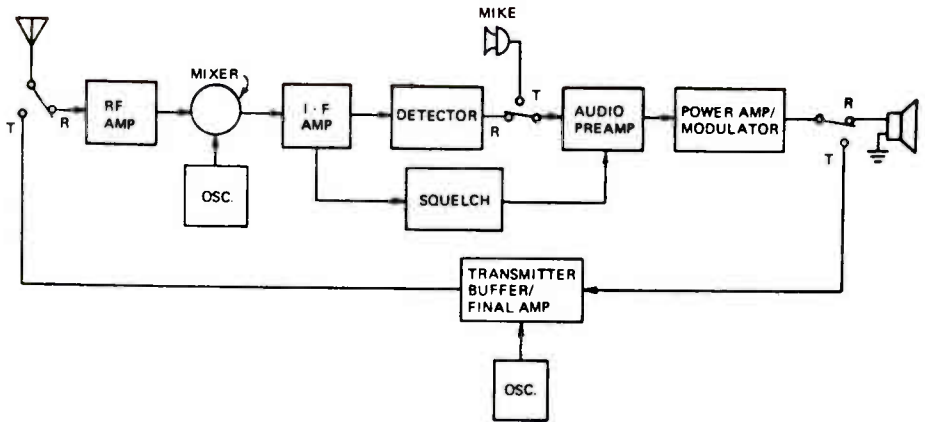

FIGURE 2. BLOCK DIAGRAM OF A CB TRANSCEIVER.

While just under one million Class D licenses are currently issued, it has been estimated that there are nearly 2.5 times that many CB sets in service. These units range all the way from the \$5 throw-away walkie-talkie to the exotic, feature-packed SSB base station priced at over \$500. This large number of diverse CB sets represents an excellent opportunity for you to expand your servicing business or start a new business servicing CB radios.

If you decide to get into this business, you will need additional items of test equipment and a Second Class Commercial FCC Radiotelephone license. You may wish to consider working for a shop which has all the necessary equipment and a properly licensed technician. By doing this, you will gain some valuable experience and learn something about the business before investing in the fairly expensive test equipment required. Any competent technician can work on a CB radio; however, the FCC Regulations clearly state that the unit must be checked by the holder of a Second Class or higher Commercial license to ensure that it meets the technical requirements before it is placed back into service.

Nearly all CB radios are transceivers. A transceiver consists of a transmitter and a receiver housed in a single cabinet. A block diagram of a typical CB transceiver is shown in Figure 2. A relay is used to switch the transceiver between the transmit and receive modes. The relay is controlled by a switch on the mike. When the mike button is pressed, power is applied to the relay coil, causing it to open the circuits at the contacts marked R and close the circuits at the contacts marked T. When the mike button is released, the transceiver is in the receive mode and the relay contacts are in the position shown in Figure 2.

The incoming 27-MHz signal is fed from the antenna through a set of contacts on the transmit/receive (TR) relay to the input of the rf amplifier. The amplitude of the signal is built up in the rf amplifier and fed to the mixer. A second signal is fed into the mixer from the local oscillator. These two signals beat against each other in the mixer to produce a difference frequency at the i-f, usually 455 kHz.

The i-f amplifier has a very narrow passband and establishes the selectivity of the receiver. Frequently, a special filter is used ahead of the i-f amplifier. These filters are of the mechanical or crystal type. They require no tuning and have a narrower passband than can be achieved using i-f transformers alone.

The strength of the signal is built up in the i-f amplifier and fed to the detector. The detector removes the modulation from the signal, discards the i-f carrier and passes the recovered audio signal through another set of contacts on the TR relay to the input of the audio preamp.

The audio preamp builds up the signal until it is strong enough to drive the power amplifier. In the power amplifier stage we are no longer interested in building up the amplitude or voltage of the signal. This stage allows the signal to control the collector current of the output stage. These variations in current are fed through a third set of contacts on the TR relay to the speaker. The changes in current cause the speaker cone to move in and out, reproducing the audio signal.

You have probably noticed that up to this point, the receiver section of a Citizens Band transceiver is quite similar to a standard broadcast band radio with the exception of the switching and the frequencies involved. However, notice the circuit connected between the i-f amplifier and the audio preamp marked "squelch." This special circuit monitors the activity in the i-f amplifier. If no signal is being received, the squelch circuit detects this condition and turns off the audio preamp. When the audio preamp is off, no signals can get through it or the power amplifier to the speaker. The circuit allows the speaker to remain silent until a signal is received.

You now have a basic idea of how the receiver section of the transceiver works. Let's see what happens when the mike button is pressed and the transceiver is placed in the transmit mode.

Pressing the mike button causes the TR relay to operate. This changes the connections by opening the circuits at the contacts marked R and closing the circuits at the contacts marked T. The mike is connected to the input of the audio preamp, the power amplifier is connected to the transmitter and the antenna is connected to the transmitter output. Notice that the receiver signal path is broken at the input of the rf amplifier and at the detector output. The speaker has also been disconnected from the circuit.

When the transceiver is in this mode, the transmitter oscillator is turned on and feeds a signal on the desired channel frequency to the buffer. The buffer serves to amplify the signal and isolate the oscillator from the final amplifier. The signal is fed from the buffer to the final amplifier where its power is increased to about 4 watts or less. The rf signal is fed to the antenna and radiated into space.

The mike is connected to the input of the audio preamp. The operator speaks into the mike, which converts his voice into an electrical signal. This weak signal is applied to the input of the audio preamp and built up in amplitude, just as the received audio signal was. The amplified signal is then fed to the power

amplifier/modulator. The output of the modulator is fed into a modulator transformer through which B+ is supplied to the final rf power amplifier. The audio signal from the mike causes the B+ applied to the final to vary, resulting in a modulated rf carrier.

Now you have a basic idea of how a Citizens Band transceiver operates. Next let's examine each stage a little more closely to see what problems may develop and how these problems would affect the overall operation of the transceiver.

RECEIVER PROBLEMS

Some of the problems that could develop in the receiver section are:

- (1) Weak reception (poor sensitivity).
- (2) Adjacent channel interference (poor selectivity).
- (3) Signals received on some channels, but not on others.
- (4) No signals received on any channel.
- (5) Squelch doesn't work.

Let's examine the receiver section to see how the various stages could contribute to these problems. Due to the limited amount of space available here, we will not discuss the function of each of the components in the typical circuits we examine. Instead, we will look for those specific components which could be responsible for the previously mentioned problems.

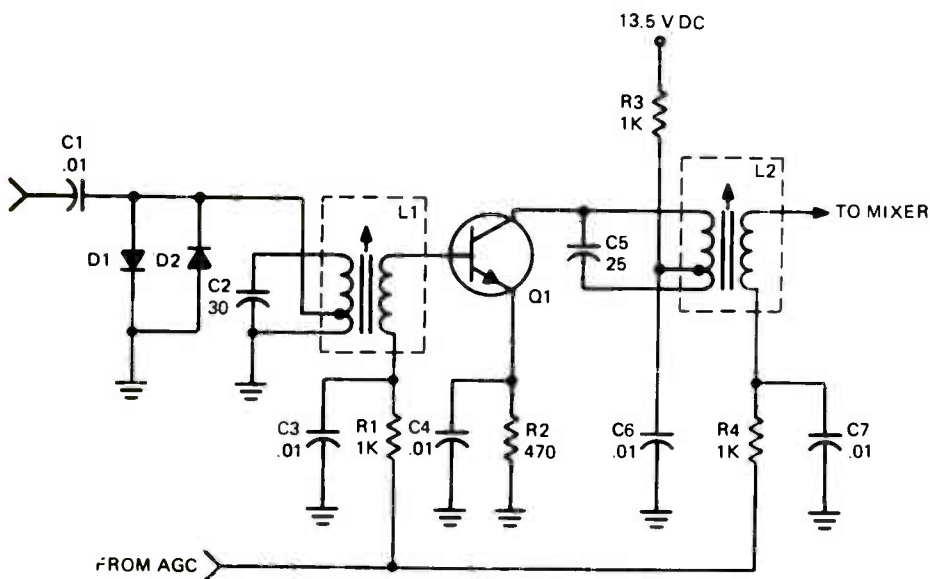

FIGURE 3. A 27-MHZ RF AMPLIFIER.

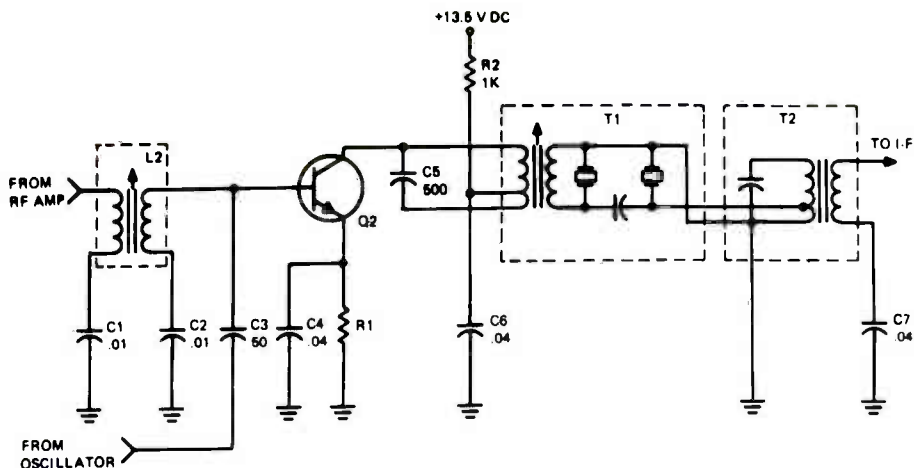

FIGURE 4. THE MIXER STAGE.

THE RF AMPLIFIER

When the problem is poor sensitivity, the trouble is likely to be located in this stage or the antenna system. Be sure to check the antenna connections to see that they are not open or corroded. Use your ohmmeter to confirm that the TR relay is switching the antenna properly. If all is okay, then check the rf amplifier.

A schematic of a typical rf amplifier is shown in Figure 3. Use your voltmeter to check the voltages at the emitter, base and collector of Q1. They should be within $\pm 20\%$ of the values given in the manufacturer's service literature for the unit you are working on. Typically, you should measure about 5 to 9 volts at the collector and the difference in voltage between the emitter and base should be about 0.7 volt for a silicon transistor and around 0.3 volt for a germanium transistor. If the voltage measurements are satisfactory, the transistor is good. If the readings are out of tolerance, the trouble may be a defective transistor or a shorted capacitor such as C3, C4 or C6.

D1 and D2 are overload diodes. They are used to protect the rf amplifier when receiving very strong signals. Lift one end of each of the diodes and test them with your ohmmeter. If one of them is shorted, no signals will reach the rf amplifier.

Poor sensitivity could also be caused by misalignment of L1 or L2, or an open bypass capacitor, C4. If C4 is open, the gain of the stage will be reduced considerably. If the problem appears to be alignment, a complete receiver alignment should be performed. If the tuning adjustments seem to have little or no effect, the trouble could be caused by an open or shorted transformer (L1 or L2) or open or shorted tuning capacitor (C2 or C5).

THE MIXER

Figure 4 is the schematic of a typical mixer. If no signals are being received, the trouble could be located in the mixer. Use your voltmeter to check the transistor

voltages as before. Use a tuned signal tracer to check for the presence of a 455-kHz signal at the mixer output. If this signal is missing, the mixer is not necessarily at fault. The trouble could be caused by the absence of a signal from the rf amplifier or the local oscillator. Both must be present in order for the mixer to work. Notice that base injection is used for both the incoming rf signal and the oscillator signal in this circuit. The oscillator signal is fed to the base of the mixer through C3. If this capacitor is suspected, it is best checked by direct substitution.

Take a look at the mixer output circuit. T1 is an i-f transformer with a crystal filter built into it. T1 and T2 are factory adjusted and normally should not be disturbed. These are the most critical adjustments in the receiver as they largely determine the receiver's ability to reject signals on adjacent channels.

THE RECEIVER OSCILLATOR

Figure 5 shows a typical oscillator used in the receiver section. This is about the simplest oscillator that could be used. A single crystal is selected by S1. The crystal causes the oscillator to operate at a frequency 455 kHz above the desired channel frequency.

When the problem is that signals are received on some channels but not on others, you can be sure that the oscillator is at fault. The trouble is usually caused by a bad crystal or dirty contacts on the channel selector switch. Occasionally the oscillator is hard to start. Check capacitors C3 and C5 by substitution.

THE I-F AMPLIFIER

The i-f amplifier consists of a minimum of two transformer-coupled stages between the mixer output and the detector. The operation of these stages can be checked by measuring the transistor voltages, the same as for the rf amplifier. When the problem is poor sensitivity, be sure to check the alignment and the emitter bypass capacitors.

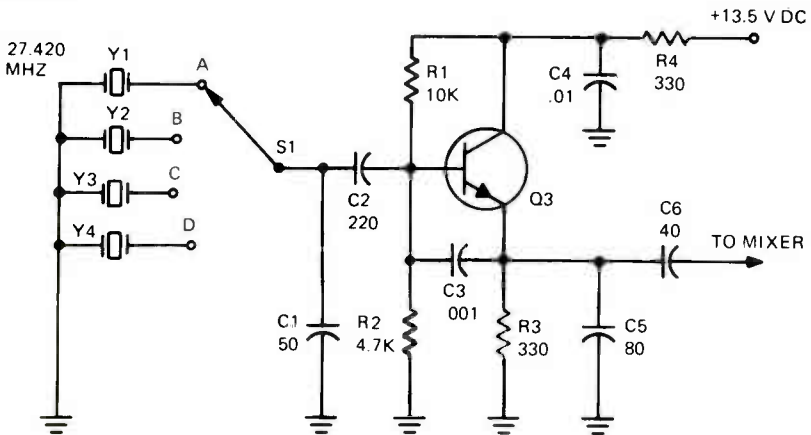

FIGURE 5. A RECEIVER OSCILLATOR.

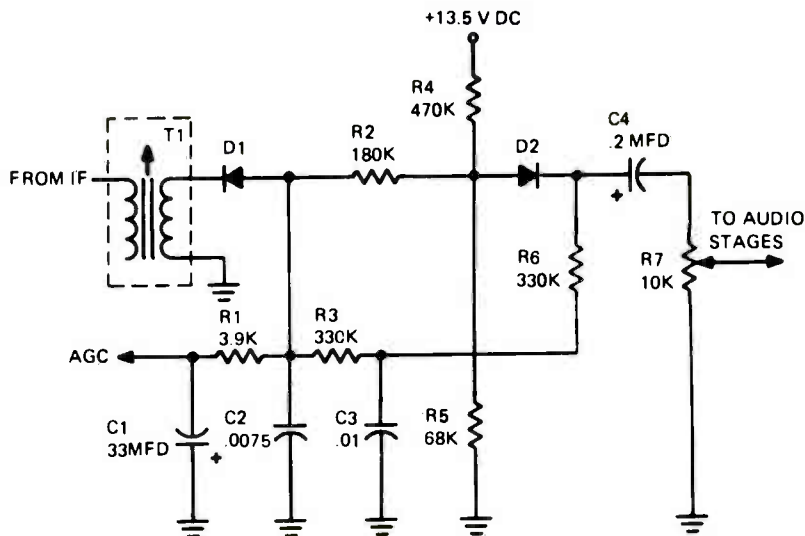

FIGURE 6. DETECTOR AND NOISE LIMITER.

THE DETECTOR AND NOISE LIMITER

A typical circuit of a detector and noise limiter is shown in Figure 6. The negative portion of the modulation envelope is removed by D1, filtered and applied to the anode of the series noise limiter, D2. Any high-amplitude noise pulses appearing on the incoming signal will cut off D2, interrupting the audio signal path until the pulses have passed. Notice that the detector also serves as the AGC rectifier.

This circuit is relatively trouble-free. Occasionally you may suspect a bad diode. These are easily checked by measuring the forward and reverse resistance with your ohmmeter.

THE AUDIO AMPLIFIERS

A schematic of the audio preamp and power amplifier/modulator is shown in Figure 7. Many manufacturers are using linear integrated circuits for the audio preamp as is shown here. Notice that the resistors necessary for the operation of this stage have been included in the IC; however, the large electrolytic capacitors used for coupling and bypassing have not been included (C1, C2, C3 and C4). This was done because it is not presently possible to obtain such large values of capacitance using integrated circuit techniques.

If the complaint is no signals received, the audio stages are a good place to make an initial test. Some units have a PA (public address) mode wherein the mike is connected to the input and the speaker is connected to the output of the audio stages. By operating the transceiver in this mode, you will be able to determine the

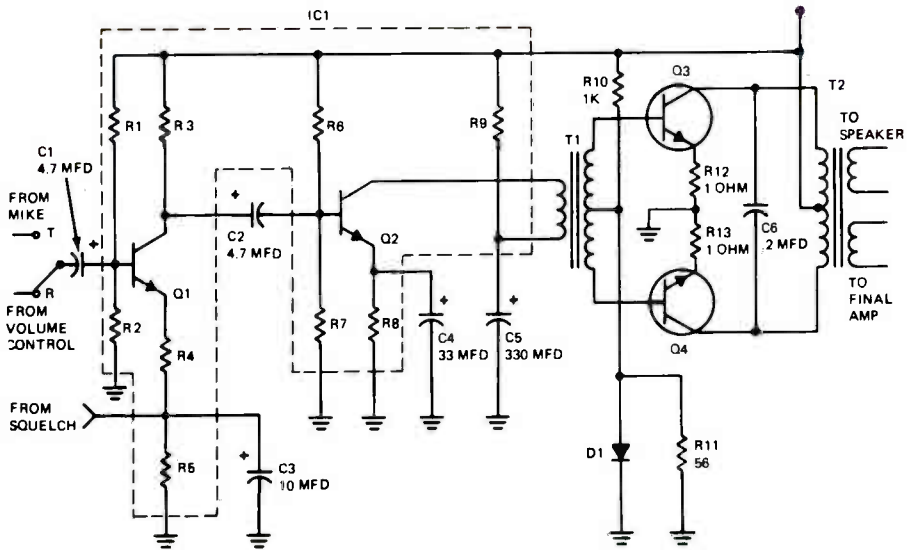

FIGURE 7. THE AUDIO PREAMP AND POWER AMPLIFIER/MODULATOR.

condition of the audio section immediately. If the amplification seems low, check the coupling and bypass capacitors as they are the components most likely to be at fault.

THE SQUELCH CIRCUIT

The squelch circuit schematic is shown in Figure 8. The circuit is basically a dc amplifier and you will be able to fully test its operation using your voltmeter. No audio or rf signals flow in this circuit. A control voltage is obtained from across the emitter resistor in one of the AGC controlled rf or i-f stages. As the strength of the received signal increases, the voltage developed across the emitter resistor is reduced due to AGC action. This lower voltage tends to turn Q1 off and Q2 on, resulting in a voltage near zero at the collector of Q2. Since this voltage is fed through a diode to the emitter of the audio preamp, the preamp functions normally.

When the incoming signal disappears, the voltage at the emitter of the rf or i-f stage increases, turning on Q1. This shunts base current away from Q2, causing its collector voltage to rise toward B+. When this high voltage is applied to the emitter of the audio preamp, the bias conditions on the stage are upset. This turns the transistor off and allows no signals to get through to the speaker.

TRANSMITTER PROBLEMS

Some problems which can develop in the transmitter section are:

- (1) Operates on some channels, but not on others.
- (2) Off-frequency operation.
- (3) No power output.
- (4) Low power output.
- (5) No modulation.

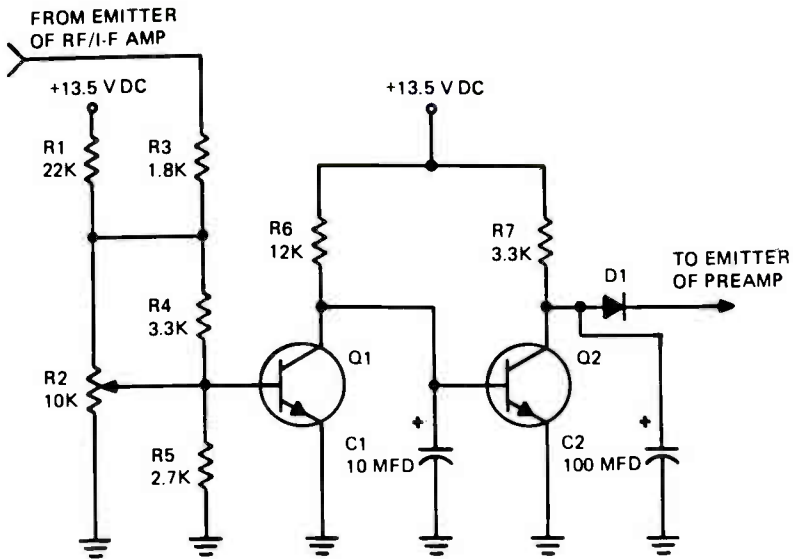

FIGURE 8. SQUELCH CIRCUIT.

THE TRANSMITTER OSCILLATOR

A diagram of the oscillator will not be given, since its operation is essentially the same as the receiver oscillator. Operation of some channels but not on others again indicates a bad crystal or dirty contacts on the channel selector switch, just as it did in the receiver section. Off-frequency operation is caused by a bad crystal. Install a new crystal and check for the correct output frequency using a frequency counter having an accuracy of $\pm 0.0025\%$ or better.

THE TRANSMITTER DRIVER AND FINAL AMPLIFIER

A schematic of the transmitter driver and final is shown in Figure 9. A buffer stage is not shown, but is usually included between the oscillator and the driver stage, Q1.

Low power output is usually caused by poor alignment of the transmitter section or a bad transistor. Measure the voltages at each transistor and compare the measurements with those given in the manufacturer's service information. Some manufacturers include rf voltage measurements which are helpful in determining whether a particular stage is amplifying the rf signal sufficiently.

A complete absence of power output can be caused by almost any stage in the transmitter. If you do not have an rf probe for your voltmeter, you can check for the presence of a signal in each stage by using a second CB radio as a test receiver. Use a short length of coax between the test receiver and the stage you are checking. Bare the center conductor for about 2 inches and solder the free end to the cable

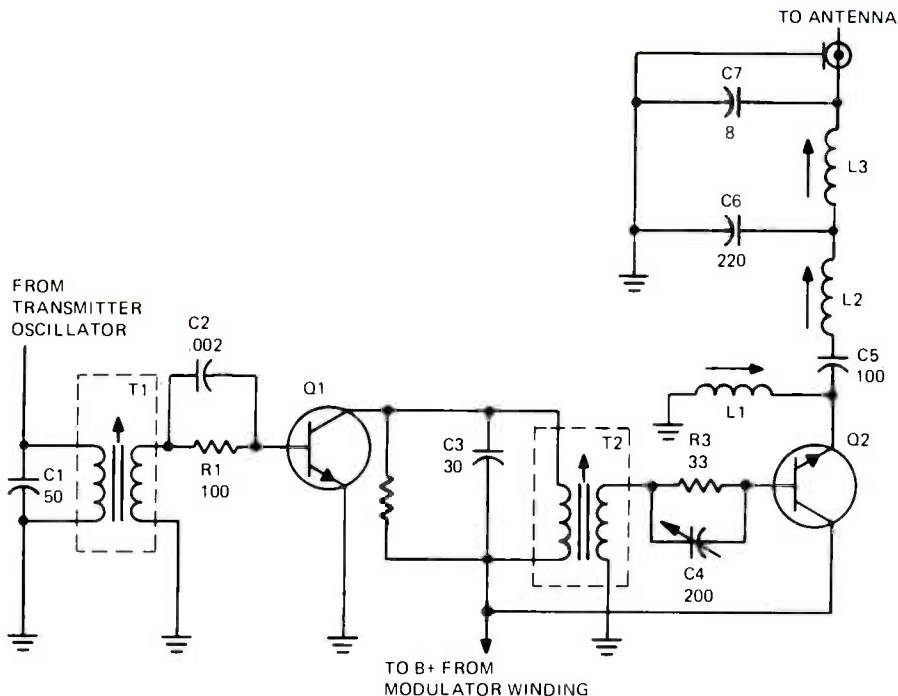

FIGURE 9. TRANSMITTER DRIVER AND FINAL AMPLIFIER.

shield to form a loop. Place the loop near the output of each stage and listen or check the S-meter for the signal.

The problem of no modulation is caused by a fault located in the mike, audio section or modulator transformer. Notice in Figure 9 that the B+ voltage for the driver and final is supplied through a winding on the modulator transformer. If the unit you are working on has a PA mode, you will be able to check the condition of the mike and audio stages as described earlier. If they are working properly, the trouble is caused by a shorted modulator winding on the power output/modulator transformer.

The information presented here was not intended to make you an expert in the maintenance and repair of CB radios, but rather to give you an idea of what is involved in this particular field. If it sounds interesting to you, you may wish to check into NRI's Complete Communications course. A special section dealing exclusively with CB radio has recently been added. The FCC Rules and Regulations, servicing procedures and equipment required, antenna types and installation of CB equipment is thoroughly covered. You perform several experiments on your own Johnson Messenger 123A, a 23-channel fully transistorized CB transceiver to demonstrate the operation of each circuit.

Recent Developments In Optoelectronics

Harold J. Turner, Jr.

First of all, just what is optoelectronics? Briefly, optoelectronics is the area of science in which the principles of electronics meet those of optics. As you know, optics is the science of light and vision. An optoelectronic device is an electronic component in which light production or light sensitivity is an important characteristic. Optoelectronic devices can be grouped into three general categories: devices which produce light; devices which are sensitive to light; and electrical isolation devices which use light as a coupling medium. Let's look at these three areas and see what types of optoelectronic devices are in use in modern-day electronic equipment.

LIGHT EMITTERS

Traditional electrically operated light emitters include incandescent lamps, where light is produced by the heating effect of an electric current in a filament, gas-discharge lamps, where light is produced by ionizing certain types of gas such as neon, and fluorescent lamps, where light is produced by bombarding a phosphorescent coating with electrons. When we speak of a light emitter in the modern sense, however, we are speaking of the light-emitting diode (LED). Just as its name says, the LED is a semiconductor diode which emits light when current is passed through it. Several LED's are shown in Figure 1.

Most present-day LED's emit a red light. The color of the light produced by a LED is a function of the materials and processes used in its fabrication; diodes emitting red light are the easiest and consequently the cheapest to make, and are therefore the most popular. However, even now green and yellow LED's are available, and

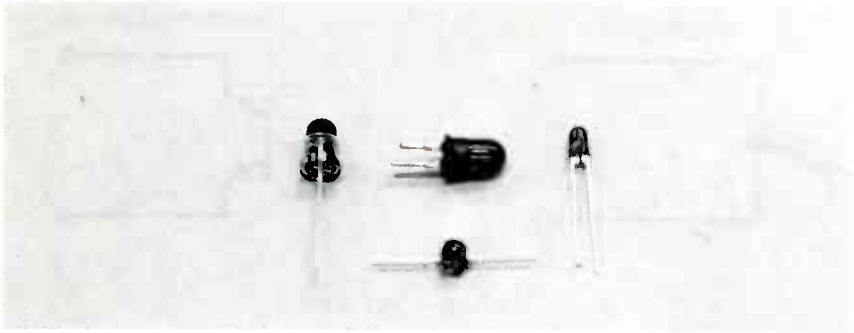

Shown actual size.

FIGURE 1. AN ASSORTMENT OF LED DEVICES.

within a few years may be priced competitively with the red emitting types. In addition to those LED's which emit visible light, there are those which emit infrared radiation, which is still a form of light, even though it is not visible to the human eye. Such LED's are used in optical coupling devices and in optical communications systems. Their output must be converted back to an electrical signal with a photosensitive device in order to be useful.

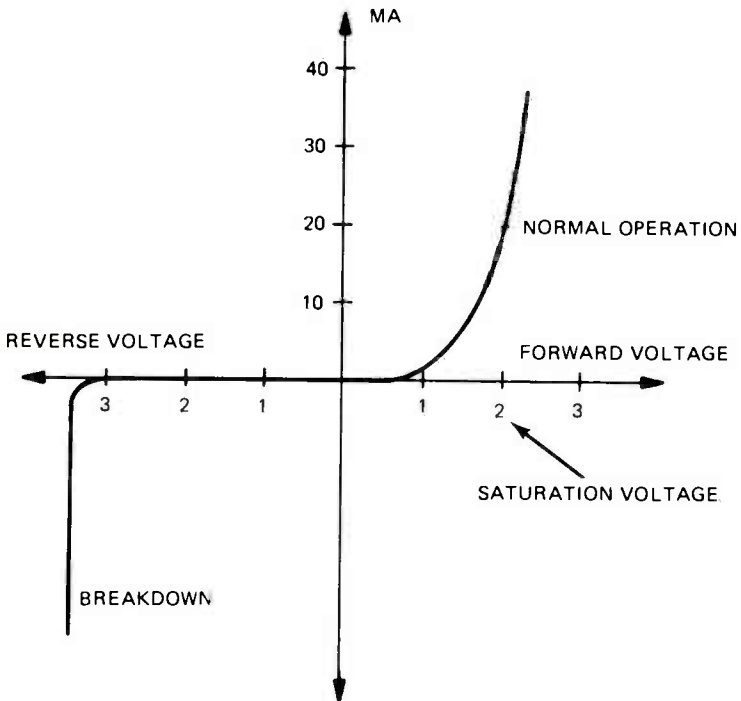

FIGURE 2. E-I CURVE OF TYPICAL LED.

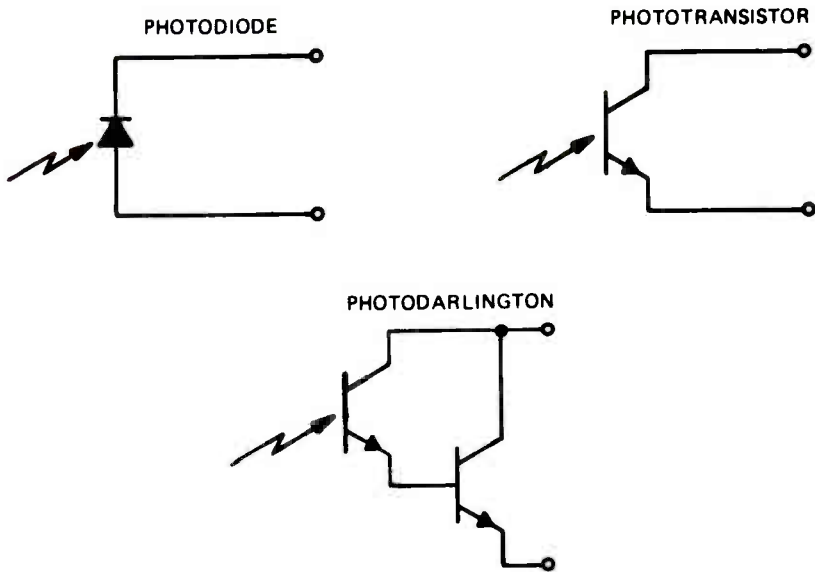

FIGURE 3. SOME COMMON LIGHT SENSORS.

Although the light-emitting ability of an LED sets it apart from the garden-variety diode, the electrical operation of the LED is very similar to that of an ordinary silicon diode. Figure 2 shows the voltage-current relationship in a typical LED. All LED's emit light only when the diode junction is forward-biased. Light output is directly proportional to current through the device in the forward direction. The typical LED diagrammed in Figure 2 has a saturation voltage of 2.0 volts, and is shown operating at a forward current of 20 milliamperes.

Since the LED is a current-operated device, it cannot be connected directly across a source of voltage, or current will be excessive and the diode will quickly self-destruct. Some means of current limiting is essential. Usually this is simply a resistor connected in series with the LED. For example, if the diode of Figure 2 were to be operated from a 5-volt source, 3 volts would have to be dropped across the current-limiting resistor, at a current of 20 milliamps. Using Ohm's law ($R = E/I = 3/0.02$), we see that the resistance would have to be 150 ohms.

LED's, or solid-state lamps, as they are sometimes called, have many advantages over older types of lamps. Among these are virtually unlimited life, high efficiency, narrow spectral range, and extremely fast turn-on and turn-off times. This last advantage becomes a particularly important one when it comes to optical coupling devices.

LIGHT-SENSITIVE DEVICES

Older types of photosensitive electronic devices include photomultiplier tubes and photoconductive cells (sun batteries). In the world of modern electronics, however,

when we think of photosensitive devices, we think of such things as photodiodes, phototransistors, and photodarlington. Some manufacturers even make such things as light-sensitive FET's and SCR's. The three most popular types of light sensors are shown in Figure 3. Each type has its advantages. In general, the higher the efficiency, or amount of output for a given input, of a photodetector, the slower is its speed of response. For example, the photodiode is the fastest of the three devices shown, with speeds in the 0.01-microsecond range, but its efficiency is very poor. Several stages of amplification are usually necessary before the signal can do useful work. The photodarlington has high gain, but it suffers from slow response, typically on the order of 50 microseconds. The phototransistor is the most popular of the three, as it offers good efficiency with moderate (1-microsecond) speed.

The photodetectors mentioned here can be used as a sensing element in industrial process control equipment, or as a motion detector in a burglar alarm system, in much the same way as older light-sensitive devices are used. But because of the high speed of response of these photodetectors, they are also useful in handling signals up into the megahertz region, either as a part of an optical isolator, or as the receiving end of an optical communications system.

OPTICAL COUPLERS

Now that we have briefly discussed the properties of light-emitting and light-sensing devices, let's put the two of them together into a single device: the optocoupler, or opto-isolator, as it's sometimes called. Figure 4 is a photograph of a typical optocoupler. The particular device shown is in a six-lead dual-inline package, roughly half the size of a standard dual-inline integrated circuit. Two of the pins along one side are connected to an internal LED, the third pin is unconnected, and the three pins on the opposite side are connected to a phototransistor. In some applications a connection is made to the base of the phototransistor for biasing purposes, but the base lead is usually left unconnected.

There are many applications in modern electronics where high- and low-frequency signals must be passed from one circuit to another while maintaining isolation between the two circuits because of operating voltage levels or grounding problems. One example would be in a data link between two pieces of digital equipment. Transformer or capacitor coupling are useless because they will not allow passage of extremely low-frequency signals. But the optocoupler has frequency response all



Shown actual size

FIGURE 4. A TYPICAL OPTOCOUPLER.

the way down to dc. In other words, if the LED is on, the phototransistor is turned on, and will remain so indefinitely, as long as the input LED is on.

Another example would be the coupling of blanking pulses from the low-voltage signal circuits of an oscilloscope to the high-voltage CRT circuits. Since a square wave must be passed, good response is needed at both very low and very high frequencies for faithful reproduction of the input signal. And, since there may be 2000 volts or more difference between the two circuits, isolation is a must. The tiny device shown in Figure 4 can be operated at voltages up to 2500 volts.

In this article we have attempted to bring you up to date on what's going on in optoelectronics. For more information on this fascinating subject, we suggest *LED Circuits and Projects* by Forrest M. Mims III. This Sams book, #21006, is available for \$4.95 from NRI's Conar Division, or from any Sams dealer.

1974 GERNSBACK AWARD

Once again NRI will cooperate with RADIO-ELECTRONICS Magazine in making an annual scholarship award of \$125 to a deserving student currently enrolled in NRI. The award will be applied toward furthering the selected student's education in electronics. NRI is one of eight home-study schools chosen to perpetuate the scholarship established by RADIO-ELECTRONICS in memoriam to Hugo Gernsback, its founder and a notable pioneer in electronics. In addition, through the generosity of RCA Electronic Components, there will be an award for the second most deserving student from each of the schools, an RCA Service Special VOM.

If you wish to nominate a student for this award (and you may certainly nominate yourself), send a letter outlining the reasons for your choice to:

Gernsback Award
National Radio Institute
3939 Wisconsin Avenue
Washington, D.C. 20016

Entries must be postmarked by May 31, 1974 to be considered. A panel of judges chosen by NRI will select the winner, and their decision will be final. (Sorry, previous winners of the Gernsback Award do not qualify for the 1974 awards.)

Written notification will be sent to the winner and announced in the September/October issue of the Journal.

Student Wins Prize In Illinois Competition

With certainly one of the most modern and unique science fair entries in recent times, NRI student Douglas Dudek has captured top honors in the electronics division of the sixteenth annual Industrial Education exhibit held at Northern Illinois University.

Douglas, who was competing against 772 individual student entries from 61 vocational schools in Illinois, received his awards for his original design and construction of an audio synthesizer.

The synthesizer, which is composed of 24 separate electronic panels, can pro-

duce electronic musical notes by use of a standard piano keyboard, or by patching the panels can produce an almost unlimited variety of electronic tone patterns, including such special effects as thunder, drum rolls, and a helicopter in flight.

Douglas, who is from Peru, Illinois, was attending the LaSalle-Peru Area Vocational center at the time of his award. An A student in NRI's SEA course, he has since accepted a position with the Westclox Division of General Time Corporation.

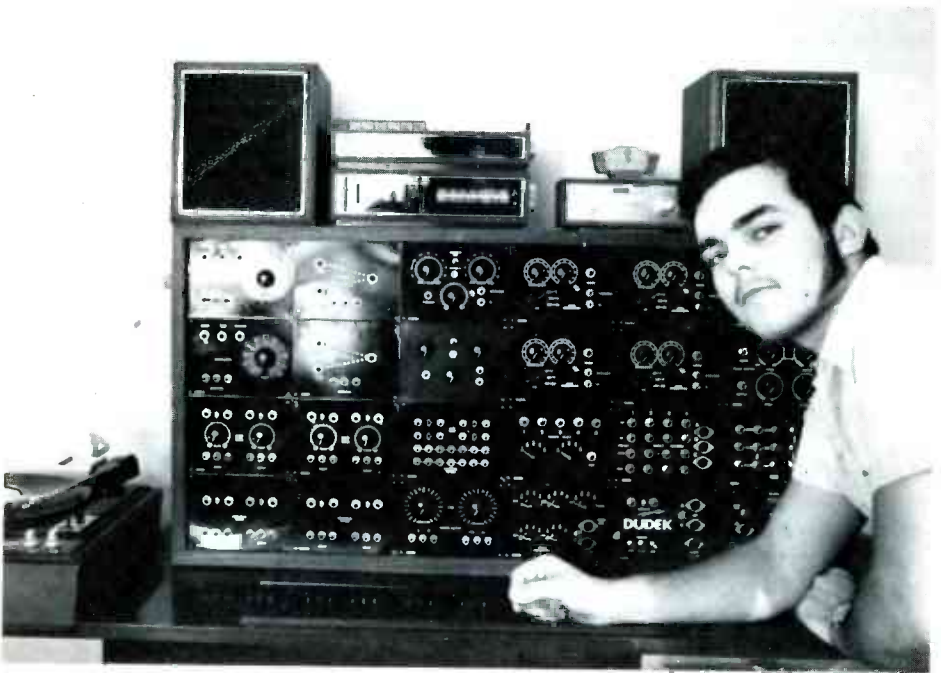

NRI student Douglas Dudek and his prize-winning audio synthesizer.

HAM NEWS



By Ted Beach K4MKX

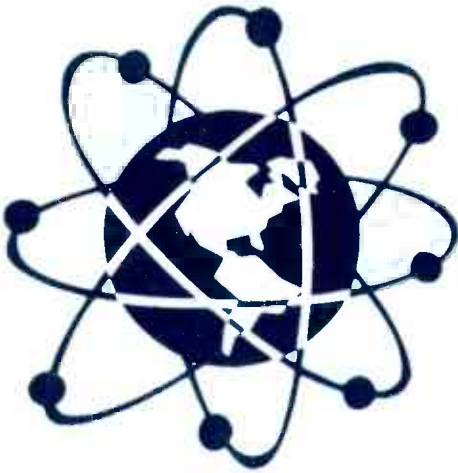

I have had quite a few letters from you people on the COS/MOS keyer I wrote about some time ago. No one has so far said that they have built one, but lots of you have said you would like to, and how about some more information on the keyer paddle? Okay, here goes.

As I mentioned some time ago, the basic keyer paddle that I dreamed up is a dual lever unit that is really not needed for the simple keyer. The dual lever is required only with the so called "iambic" keyer or one which has dot and dash memories. At any rate, this type of paddle works well with the COS/MOS keyer, and it is very simple to put together. I don't think that I would be inclined to try using it with any other type of keyer, because the contact resistance could be a little high. With the COS/MOS ICs, however, the contact resistance is no problem whatsoever. In fact, I can put dry fingers across the contacts and rip out perfectly readable code (body resistance runs about 100 K to 470 K).

The diagram in Figure 1 is an exploded view of the dual lever paddle. There are

four 6-32 screws, some flat washers, a couple of pieces of paper clip, some 6-32 nuts, a piece of perf-board for the base, and two lengths of double-sided circuit board. I have not put any dimensions on the sketch because none of the dimensions is critical. The first unit I built went together by intuition.

A good starting point for the paddles themselves is about half the size of a

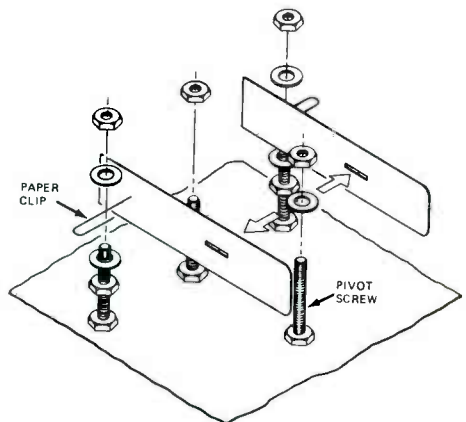

FIGURE 1. EXPLODED VIEW OF DUAL LEVER KEYER.

doctor's tongue depressor — about 5/8 inch high by about 3 inches long. The two center screws will have to be longer than the width of the paddles plus the thickness of two 6-32 nuts (about 1/8 inch). You will have to make a slot in both the paddles that will freely pass a standard No. 6 flat washer. This is easily done by drilling a series of small holes through both paddles together and then sort of "worry" the holes into a slot.

Drill a small hole in both paddles near the slot and solder a "jumper" wire in each hole to connect the two sides of the circuit board together. This will allow the pivot screw to serve as the paddle "common" terminal.

Put the washer in the slots and slide the assembly down over the pivot screw (the one on the right in the figure) as you hold the two paddles together. When they are in the proper position, they will rest against the two center screws and the washer will prevent any back and forth movement. Lightly tie a small length of a cut rubber band around both paddles between the two screws. Don't tie this too tightly or the paddle movement will be too stiff. You will have plenty of adjustment range for the keying tension without tying the band tightly.

Lightly screw 6-32 nuts onto the two center screws to hold the paddles on the screws. The paddles should be free to move. You can lock the nuts in place by putting a bit of rubber cement on the threads. This will come off easily if you ever need to disassemble the paddle.

Now assemble the dot and dash contacts on the two outer screws as shown. I use two No. 6 flat washers, two 6-32 nuts and a half paper clip for each set of contacts but even a length of hookup wire would do for the contact. Adjust the two nuts so that the contact wire (or paper clip) is



FIGURE 2. COS/MOS KEYER BUILT INTO TRANSISTOR RADIO CASE.

about even with the center of the paddle. You can easily vary the contact spacing by moving the wire in and out, then tighten the nut to lock it into position.

You adjust the tension of the paddles by moving the rubber band toward or away from the pivot screw — away to increase, toward to decrease. You should adjust the contact spacing and tension together for the "feel" that you like.

And that's about it. I'm sure that you can do a much better job than I on this "mechanism" as I am the world's worst mechanic. Anyway, I have built three paddles, and each one has been different! All of them work, though, and the last one took exactly 15 minutes to build.

You might be interested in the Mark II keyer I mentioned in the first article on the keyer way back when. I'm not going to include the schematic as I have not laid out a circuit board for it yet. The one model I built (after the breadboard stage) fit very nicely into the case of a defunct portable transistor radio as you can see in Figure 2. The radio furnished the side-tone speaker, cabinet and battery, as well as a board to mount the parts on. I took off all the radio parts and ground the foil off of the circuit board. All of the parts are "hard wired" with tiny hookup wire

on the underside of the circuit board. I don't recommend this practice as it can be very exasperating!

Figure 3 shows the inside of the unit. Perhaps you can get a better idea of how the keyer paddle goes together from this figure. As you can see, it all fits inside quite snugly (you should see the other side of the board!).

You might notice that I have shaped the paddles on this keyer somewhat differently from the shape shown in Figure 1. This was necessary because of the limited space inside the radio case. Also you may see that I removed the foil from the paddles on the outside of the radio case. This was done to avoid contact with the keying voltage present at the common (paddle) terminal when connected to my Ranger which is grid block keyed. By doing this, there is no exposed electrical part on the keyer.



FIGURE 3. INSIDE OF THE KEYSER.

I have just about finished laying out the foil pattern for this keyer on a circuit board that should be small enough to fit inside most similarly shaped transistor radio cabinets. When it is complete, perhaps I will run it here in the column for you to use. There is no provision on this unit for an adjustable tone control. This is because there just isn't any room for

Harry	WB2MDX	A	Woodstock NY
Pat	WN2NNP	N	Forest Hills NY
H.J.	WB4GRL	A	Hilton Head Island SC
Jim	WN5ITZ	N	Gliddings TX
Doc	W5WBY	-	Lamesa TX
Dale	WN6BYS	N	Sacramento CA
Louise	WB8JIB*	G?	Yellow Springs OH
Sister Marjorie	WN8OUD	N	Cincinnati OH
Darwin	K8PLZ	-	Flint MI
John	WN8QWZ	N	Rochester MI
Jim	WB8IEH	-	Ishpeming MI
Hal	WN9LJR	N	Henry IL
Gary	WN0LUW	N	Minneapolis MN
Lloyd	WN0MDG	N	O'Neill NE
Carlos	WP4DSY	N	Rio Piedras PR
John	WB4QID	G	Lakeland FL
Charlie	WB5FZJ	E	Leesville LA
Mike	W6DYC/7	-	LaGrande OR
Edwin	WA6WNI*	A	Sacramento CA
Bob	WB8BOR	-	Westlake OH
Lou	WN0IYC	N	St Paul MN

* Just upgraded - Congratulations!

three controls in such a small enclosure (speed, volume and tone). It is an easy matter to select a fixed resistor to produce a pleasing tone output.

Now, let's see who we've heard from since last time. As usual, those listed first are students and graduates of the NRI Amateur courses.

In addition to those people in the list I also received a note from a CBer (who hopefully is going on to better things) and a QSL from a CREI student! Oh, well.

I have rambled on so long about my pet project this time that there is very little room left to include the comments passed along by some of the above. There were a couple of questions on the keyer, which I

hope this article has answered, and some other questions which I will answer personally when I can get a couple of minutes to dash off a note.

WB4QID notes that he was the one I mentioned in the January/February column as having passed traffic to my daughter who did not quite understand what it was all about. Thanks, John, I always hate to have unsolved mysteries on my hands!

Next time we'll have more room to pass along your news and views. For now we'll say 73 and thanks for all your nice notes. Be sure to look over the Ham Ads—remember, they're free.

CUL

Ted — K4MKX

Ham Ads

WANTED: One No.12 or WD12 tube, one No.112 or 71A tube, Rider's manuals I, II, III, IV, V, VII, VIII. Contact J.B. Clay, Box 456, Oxford, NC 27565.

FOR SALE: Knight T-60, \$50. Heath HR-10B, \$75. Heath code practice oscillator and key, \$8.50. Heath GR-54, \$80. Heath GW-21A, \$27.50. All have manuals and will ship within the continental U.S. Contact Richard Tieskotter, Route 1, Lawler, IA 52154.

A REMINDER...

For your own protection, please do not send cash to NRI when making your tuition payments or CONAR remittances. Send your payments by check, draft, or postal money order. This will ensure against the loss of your remittance and will provide you with a record of your payment.

NRI HONORS PROGRAM AWARDS

During the months of January and February, 1974, the following NRI graduates received, in addition to their NRI electronics diplomas, CERTIFICATES OF DISTINCTION under the NRI Honors Program for outstanding grades throughout their NRI training. This distinction is made part of their permanent NRI records and appears on all transcripts of records requested. NRI worldwide leadership in electronics training is represented by these outstanding graduates from almost every area of the United States, from Mexico and Canada, and other foreign countries.

WITH HIGHEST HONORS

Donald Heslop Andrews, Victoria, BC, Canada

Hugh F. Barlow, Titusville, FL
Roger L. Blakley, Platte City, MO
Medford E. Conley, Portsmouth, NH
Louis Dalessandro, Succasunna, NJ
Ronald H. Dunigan, Fairborn, OH
Alfred Joseph Garcia, Buena Park, CA
Richard W. Giard, Lee, MA
David M. Haerle, Edwards, CA
Steve J. Halmo, Cupertino, CA
Douglas C. Hewitt, Livonia, MI
Thomas Hulehan, Southboro, MA
Alex V. Kurian, Bel Air, MD
Roger C. Laudati, Annandale, VA
Robert D. McClaren, Orient, OH
Clarence L. Monta, Basking Ridge, NJ
Carry H. A. Naepflein, Smithtown, NY
Larry Plett, Landmark, MB, Canada
Lewis E. Prine, Birdsboro, PA
Phillip E. Redman, La Grange Park, IL
William Dean Smart, San Diego, CA
Richard Smith, Phillipsburg, NJ
N. Unalp, Sparta, NJ
Daniel R. White, Ocean Springs, MS
Harold W. Wilder, Mississauga, ON, Canada
John A. Wildi, Jr., Reynoldsburg, OH
Norbert Martin Wilson, Laborie St. Lucia West Indies
R. E. Yake, Wappingers Falls, NY

WITH HIGH HONORS

Donald Abernathy, McAllen, TX
Ira C. Adams, Bristol, WV
Richard J. Adams, Sr., Peekskill, NY
Floyd F. Austin, Jr., Fairbanks, AK
Gene R. Bailey, Newark, OH
Raymond Benjamin Bass, Reno, NV
Robert J. Bedow, Pacific Grove, CA
Ronald B. Beeson, Woodsfield, OH
John A. Bisson, Burlington, VT

Raynold C. Bondeson, Sterling, VA
Jeff W. Booth, St. Louis, MO
William C. Bradley, Jr., Dallas, TX
James C. Brinton, Chalfont, PA
Robert L. Broene, APO San Francisco
Vincent N. Bush, Manhattan Beach, CA
Anthony J. Canterbury, Idaho Falls, ID
Rosser W. Carey, Miami Springs, FL
Carolyn E. Carter, Austin, TX
Louis E. Charlton, Elyria, OH
James J. Cloonan, Roy, UT
James L. Counter, Thief River Falls, MN
James Robert Dean, Jr., La Vale, MD
James C. Diebold, Warren MI
Richard Dirks, Lakeville, MN
Loren L. Donley, Lena, MS
V. J. Doran, Burbank, CA
Donald L. Dukes, Fort Leavenworth, KS
Trevor R. Earle, St. Petersburg, FL
Carl E. Falconer, Scotia, NY
Sydney S. Fleck, II, Albany, GA
Edward J. Franczkowski, Baltimore, MD
Jones W. Frazier, Jr., Birmingham, AL
Bruce B. Fuller, Centereach, NY
George Green, Grandview, MO
Jack W. Hamlin, Huntington, WV
Martin J. Hanlon, Maspeth, NY
Lou Hannaford, Cape Girardeau, MO
Ronald M. Hatfield, Cabin Creek, WV
Carroll C. Hayhurst, Fountain Valley, CA
C. Thomas Hectus, Louisville, KY
Wallace D. High, Rockville, MD
Milton J. Hocker, North Highland, CA
James Hoffmann, Algona, IA
Harry W. Horchler, Jr., Norfolk, VA
Jerry R. Jenkins, Morgantown, NC
Harry H. Johnson, Jr., Woodstock, NY
William J. Kaczmarczyk, FPO New York
Carl R. Klager, Sonoma, CA
Edward J. Knight, Peoria, IL
John J. Kutz, Jr., Canton, OH
William J. Lafond, Pascoag, RI
James W. Lasswell, Richards-Gebaur AFB MO
David Laukat, Oklahoma City, OK
Michael LePera, Newton, NJ

Charles F. Letsche, APO New York
 Donald A. Lewis, APO New York
 David C. Liebergen, Green Bay, WI
 James W. Lusk, Camp Springs, MD
 Leon Madkins, San Angelo, TX
 Kevin R. Mahan, Warehouse Point, CT
 George Mamula, Washington, PA
 John Marrin, Wood-Ridge, NJ
 Ted Bert Mattinson, Codette, SK, Canada
 William K. McCoy, FPO Seattle, WA
 Thomas P. McCurdy, Hoffman Estates, IL
 Newton C. McFall, Jr., Chattanooga, TN
 Russell McWhinney, Jr., Front Royal, VA
 Herbert Mitschan, Petaluma, CA
 Ross E. Molzahn, Thatcher, AZ
 Thomas E. Moseman, Hampton, VA
 James F. Mutney, Lebanon, NH
 William H. Nichols, Rosemount, MN
 Paul E. Novak, Key West, FL
 Earnest W. Owings, San Angelo, TX
 William T. Paine, Jr., San Diego, CA
 Leonard T. Parish, Fullerton, CA
 Ross Pattershall, Hackensack, NJ
 David H. Perry, Newfane, NY
 Randall Lee Peterson, Rockford, IL
 Paul W. Powell, Electric City, WA
 Dennis Pramagioulis, Bronx, NY
 Walter B. Pritchett, Burton, SC
 Kenneth D. Rankin, Bellingham, WA
 William W. Riker, White Meadow Lake, NJ
 Harold A. Roach, Modesto, CA
 Jack Roberson, Rantoul, IL
 Earle L. Sanders, Lynn Haven, FL
 Kurt W. Schroff, Chicago Heights, IL
 Kurt H. Schuler, El Paso, TX
 Harry C. Shilling, Philadelphia, PA
 Raymond Silfa, Washington, DC
 Hank Smith, Albuquerque, NM
 John Soares, III, Yonkers, NY
 David P. Sopala, Taylor, MI
 Paul S. Spangler, Jr., Greenville, NC
 Harvey Jay Steinfeld, Rockville, MD
 Brett M. Stephens, Lynchburg, VA
 Billy E. Styles, Greenville, SC
 Gary N. Sylling, Wurtsmith AFB, MI
 Hugh V. Tate, III, APO Seattle
 John R. Theys, APO New York
 John S. Tuttle, Danville, CA
 Lawrence M. Vied, Aurora, CO
 James A. Walsh, Waltham, MA
 Wayne L. Walter, Marion, IA
 Miin-Nan Wang, Manhattan, KS
 Alvin D. Watkins, Doraville, GA
 Douglas G. Weaver, Theodore, AL
 Ivan F. Williams, Jr., APO New York
 David Woodin, Reno, NV
 Maria Cristina Yasakci, Montreal, PQ,
 Canada
 Phillip E. Young, Marion, IN

WITH HONORS

Jerry A. Abee, APO New York
 Alan F. Anderson, Sr., Morton, MA
 Luther J. Ash, Woodbridge, VA
 Herbert R. Baehm, Middletown, NY
 Antonin Bartunekh, Toronto, ON, Canada
 Connie G. Bellah, Fort Worth, TX
 Thongchai Bhanukitsiri, Commerce, CA
 Earl Bigger, Lexington, VA
 Lynn H. Blakely, Bethany, OK
 Edwin L. Bobo, Parkton, MD
 James N. Bohner, Honolulu, HI
 Don R. Boucher, Milo, IA
 J. W. Bowles, San Antonio, TX
 Thomas E. Britton, APO San Francisco
 King D. Broadnax, Jr., Statesboro, GA
 Giles E. Brown, Affton, MO
 John L. Case, Neah Bay, WA
 Robert E. Chaney, Signal Mountain, TN
 Wiley G. Clark, Virginia Beach, VA
 James R. Coleman, Washington, DC
 Billy B. Daniel, Albuquerque, NM
 Nicholas D'Aurizio, Batavia, NY
 Paul G. Davis, Carthage, TN
 Carl T. Dickerson, Lewisville, NC
 William K. Duckworth, Mount Vernon, IN
 Robert J. Duncan, Bethlehem, PA
 Daniel C. Egbert, APO New York
 Robert Edward Ehlers, Taylors, SC
 William Etsell, Philadelphia, PA
 Francis C. Ettenhofer, Escanaba, MI
 William Fitzpatrick, Camp Springs, MD
 Bruno Franchi, Monmouth Junction, NJ
 Robert F. Frederick, Watertown, WI
 William E. Germann, FPO Seattle
 John R. Gilmore, Jr., Philadelphia, PA
 Marvin G. Gsell, Sun Valley, CA
 Robert A. Halstead, APO New York
 Frank Halter, San Francisco, CA
 Clinton D. Hamilton, Fallbrook, CA
 Malcolm R. Hanson, East Fairfield, VT
 James F. Harris, Berryville, VA
 Raymond M. Hartinger, Eden, NY
 Joseph Hatton, Manchester, NH
 Trulan P. Hatton, Peru, IN
 Kenneth E. Hintz, Plattsburgh, NY
 Michael A. Hitchens, Somerset, OH
 Richard W. Hogan, Jackson, MI
 Gary T. Hoke, Spring Grove, PA
 James E. Hood, Irondale, OH
 Kenneth K. Horlander, Danville, IL
 James A. Howlingcrane, Okmulgee, OK
 Tim C. Hudson, Ogallala, NE
 George E. Ingle, Burlington, NC
 Thomas M. Jarboe, Indianapolis, IN
 David F. Jirovsky, Cedar Bluffs, NE
 Landon R. Jones, Jr., Fairfax, VA

Myron B. Jordan, West Bend, WI
Joseph G. Keithley, Jr., Fort Dix, NJ
Robert Manley Knight, Wedowee, AL
Forrest G. Knowles, Coleville, CA
R. Kolthoff, Trois-Riv Quest, PQ, Canada
James M. Kreck, Newark, DE
Allen Kwant, Jr., Marysville, WA
Christopher L. LaColt, Dauphin Island, AL
Albert E. Lane, Nashville, TN
R. B. Lariviere, Auburn, MA
Ronnie D. Larson, Hyrum, UT
Kenneth L. Lawrence, St. Clair Shores, MI
Stephen K. Lebo, Falls Church, VA
Melvin Leow, Toledo, OH
Earle B. Lloyd, Jr., APO New York
Robert J. Lorenz, Rockford, IL
Thomas L. Lufkin, Charleston Heights, SC
William G. Lyles, Sheridan, WY
Joseph F. Lynch, Yonkers, NY
F. J. Magnuson, Prescott, AZ
John Maley, Amherst, OH
Kenneth C. Malley, Fort Washington, MD
Joseph M. Mansfield, Jamaica Plain, MA
Rudolph A. Marano, Brooklyn, NY
William Maronek, Stevens Point, WI
Rod Mason, St. Louis, MO
Jack A. Massa, APO San Francisco
William Carl Masters, Fort Mill, SC
Duncan D. McAuley, Medley, AB, Canada
Ralph R. McConahy, Export, PA
James W. McKinney, Jr., Opheim, MT
Paul E. Medlen, Jacksonville, FL
Elliott P. Messing, Athens, GA
George L. Meyers, Menasha, WI
Roy E. Milburn, Reno, NV
George B. Miller, Jr., Mederland, TX
Joe J. Mullet, Jr., South English, IA
Grady M. Nations, APO New York
George W. Orth, Interlachen, FL
Anthony J. Osso, Youngstown, OH
William W. Overton, Lawton, OK
Warren J. Pawlik, Jr., Reading, PA
Laurence C. Peacock, Lowville, NY
Robert K. Petrich, Jacksonville, FL

Aaron Laiton Pettus, Jr., Fort Mill, SC
James H. Pfitzner, Spokane, WA
Robert P. Pippin, Altamonte Springs, FL
Michael S. Pollock, San Pedro, CA
Frank A. Pugliano, West Carrollton, OH
Russell R. Pyle, West Palm Beach, FL
John J. Quinn, Jr., Annandale, VA
Christian Rampin, North Bellmore, NY
McClure L. Rasnake, Gainesville, FL
Lloyd A. Reiser, Winton, CA
Richard C. Ricke, Osgood, IN
Talbot V. Ridgway, APO San Francisco
George Charles Riggs, Dayton, TN
Jimmy L. Robinson, Abilene, TX
John P. Ruebsamen, Oxford, NY
Jerome Rush, Union, MS
Bruce W. Santibanez, Columbus, OH
Jack M. Scates, Brandywine, MD
Marvin J. Scruggs, Jamaica, NY
Don Seehafer, Dayton, OH
William B. Sellers, Marianna, FL
Gregory A. Shaw, Albany, OR
Robert W. Siegel, San Diego, CA
William J. Smith, Lewisporte, Nfld, Canada
Robert G. Smithley, Windham, OH
Paul B. Sobieck, Jr., West Baraboo, WI
Paul Soder, Jr., Grand Rapids, MI
William R. Sonnenberg, North Massapequa, NY

Robert M. Stanley, San Antonio, TX
John L. Still, Middletown, PA
Ernest N. Storms, FPO Seattle
Walter F. Stroot, Euclid, MN
Robert K. Tomblin, Wayne, WV
A. J. Vaicjurgis, Dorchester, MA
Lester L. Warren, McGuire AFB, NJ
Cleo G. Watson, Scottown, OH
Doug Wayne, Castro Valley, CA
Robert M. Whelan, Portsmouth, NH
Wallace F. Wilms, Moss Point, MS
David S. Woods, Rutland, VT
James B. Woody, Pease AFB, NH
Ronald E. Wrubel, Warehouse Point, CT
Jose C. Zapata, Santa Monica, CA

QUESTIONNAIRE

To enable the staff of the NRI Journal to better serve our readership, we would appreciate it if you could take the time to fill out the following questionnaire.

1. Which features in the Journal interest you the most?
 - Articles on new electronic equipment and components
 - Articles on electronic theory and design practices
 - Articles on practical servicing and repair of electronic equipment
 - Articles on designing and building your own electronic equipment
 - Ham News
 - Alumni News

2. Which features interest you the least?
 - Articles on new electronic equipment and components
 - Articles on electronic theory and design practices
 - Articles on practical servicing and repair of electronic equipment
 - Articles on designing and building your own electronic equipment
 - Ham News
 - Alumni News

3. What additional features would you like to see included in the Journal?

4. What features do you feel should be eliminated from the Journal?

5. How do you feel about the quality of writing in the Journal?
 - Excellent, clear and understandable
 - Good, but could use some improvement
 - Average
 - Poor
 - Too high level
 - Too basic level

6. Please use the following space to indicate any suggestions, criticisms, or general comments you may wish to make.

When you have completed the questionnaire, please mail it to:

Tom Beadling
Managing Editor, NRI Journal
3939 Wisconsin Avenue
Washington, D.C. 20016

FA-374*

DIRECTORY OF ALUMNI CHAPTERS

CHAMBERSBURG (CUMBERLAND VALLEY) CHAPTER meets at 8 p.m., 2nd Tuesday of each month at Bob Erford's Radio-TV Service Shop, Chambersburg, Pa. Chairman: Gerald Strite, RR1, Chambersburg, Pa.

DETROIT CHAPTER meets 8 p.m., 2nd Friday of each month at St. Andrews Hall, 431 E. Congress St., Detroit. Chairman: James Kelley, 1140 Livernois, Detroit, Mich. 841-4972.

FLINT (SAGINAW VALLEY) CHAPTER meets 7:30 p.m. twice a month every other Wednesday at Andy's Radio and TV Shop, G-5507 S. Saginaw Rd., Flint, Mich. Chairman: Larry McMaster, (517) 463-5059.

NEW YORK CITY CHAPTER meets 8:30 p.m., 1st and 3rd Thursday of each month at 199 Lefferts Ave., Brooklyn, N.Y. Chairman: Steve Kross, 381 Prospect Ave., Brooklyn, N.Y.

NORTH JERSEY CHAPTER meets 8 p.m., 2nd Friday of each month at The Players Club, Washington Square. Chairman: George Stoll, 10 Jefferson Ave., Kearney, N.J.

PHILADELPHIA-CAMDEN CHAPTER meets 8 p.m., 4th Monday of each month in RCA Building, 204-I, Route 38 in Haddonfield Rd., Cherry Hill, New Jersey 08034. Chairman: Joe Szumowski.

PITTSBURGH CHAPTER meets 8 p.m., 1st Thursday of each month in the basement of the U.P. Church of Verona, Pa., corner of South Ave. and 2nd St. Chairman: George McElwain.

SAN ANTONIO (ALAMO) CHAPTER meets 7 p.m., 4th Thursday of each month at Alamo Heights Christian Church Scout House, 350 Primrose St., 6500 block of N. New Braunfels Street (three blocks north of Austin Highway), San Antonio, Texas. Chairman: Norman Bird. All San Antonio area NRI students are always welcome. A free annual chapter membership will be given to all NRI graduates attending within three months of their graduation.

SOUTHEASTERN MASSACHUSETTS CHAPTER meets 8 p.m., last Wednesday of each month at the home of Chairman Daniel DeJesus, 12 Brookview St., Fairhaven, Mass. 02719.

SPRINGFIELD (MASS.) CHAPTER meets 7 p.m., 2nd Saturday of each month at the shop of Chairman Norman Charest, 74 Redfern Dr., Springfield, Mass. 734-2609.

TORONTO CHAPTER meets at McGraw-Hill Bldg., 330 Progress Ave., Scarborough, Ontario, Canada. Chairman Branko Lebar. For information contact Stewart J. Kenmuir (416) 293-1911.



FLINT-SAGINAW CHAPTER HAS VARIED ACTIVITIES

At the January 16 meeting, the subject was "Are You Making Any Money?" Take an inventory of your stock and have your merchandise coded so that you will always know how much it cost originally so that when the time comes to use it there will be no question of cost.

Being the end of the year, Andy Jobaggy gave instructions on what type of deductions the IRS will accept on your business and what you are entitled to take on your income tax form so that you will not lose money in the business.

Mr. Steven Avetta made a motion that our dinner be on January 30 and the motion was carried. All agreed to have Hungarian breaded chicken for the dinner.

Mr. Herald from the University of Michigan spoke on CET and the chapter enjoyed his talk and advice. Mr. Jobaggy demonstrated a new Magnavox black-and-white TV with new-type circuitry. Mr. Cash Laferty told about a service hint using a circuit cooler on intermittent transistors.

The January 30 chicken dinner was a great success and everyone enjoyed it immensely.

NRI AA OFFICERS

James Kelley.....President
William W. David.....Vice President
Albert H. Sharp.....Vice President
W. L. Simmons.....Vice President
Arnold E. Verdow...Vice President
Tom Nolan.....Exec. Secretary

Alumni News

Mr. Avetta gave a few pointers on how to save electricity and a few pointers on electrical wiring such as using heavy enough wire on water pumps so that the motors will not burn out. As the power companies are cutting back on voltage there is always a possibility of overheating some motors while under load.

Mr. Jobaggy showed the chapter the new RCA transistor checker and every member had a chance to learn how to operate the checker and to test all kinds of transistors. Mr. Dennis Besser brought in a 1934 Stewart-Warner radio which was defective. In order to repair this radio, two old-timers, Mr. Clyde Morrisette and Mr. Jobaggy, delved into the old Riders manuals and by the Rider system of part numbering they were able to decipher the parts in this old receiver and get it operating. The young members learned a lot from the old-timers.

PLEASE NOTE . . .

All new chapter officers and Secretaries are urged to send in their reports of chapter meetings and activities as soon as possible for inclusion in the Alumni News.

Mr. Frederick Malik asked the chapter members if it were possible for a picture tube to have a minute air leak and still operate. The answer is yes—however, the picture will not be very acceptable.

SAN ANTONIO CHAPTER ELECTS NEW OFFICERS

At the January meeting, Mr. Ted Walker, TV shop manager, gave a talk on TV dogs. The talk was very instructive as Ted is one of the most knowledgeable electronics men in the area.

Nominations were completed and at our February meeting the officers were elected and installed. They are Norman Bird, Chairman; J. J. Harrison, Vice Chairman; Madeline Rogers, Secretary; and Sam Dentler, Treasurer. We all welcome the new officers to their positions.

A discussion was held on the merits and advisability of holding a class for persons interested in taking a test to become a certified electronics technician.

The treasurer's report at this meeting showed that the chapter is well in the black and financially in good shape.

SPRINGFIELD CHAPTER CHAIRMAN GIVES TALK

At the January meeting of the Springfield chapter, Mr. Arthur Byron, the Chairman, who is a self-employed TV service man, spoke on various problems.

His subject concerned safety while working on TV chassis. With a transformerless-type TV set and an oscilloscope, Mr. Byron demonstrated how the TV chassis could give a person a lethal shock, and stressed the importance of an isolation transformer in service work.

Mr. Richard Damon, a student, was a guest at this meeting.

DETROIT CHAPTER WELCOMES NEW MEMBER

At the year-end meeting of the Detroit chapter, Mr. Carl Ceruti was admitted as a new member.

The Treasurer reported a balance of \$48.06 on hand and Mr. Kelley was notified that he had won the National Presidency for 1974.

Mr. Kelley demonstrated an intermittent transistor using an oscilloscope and the meeting adjourned at 9:30.

As the weather gets better the chapter is looking forward to larger attendance and good programs.

CONAR offers...for the man (or woman or boy or girl in your life)...the unique styling of

THE MOTOR WATCH

Racing flags in full color add to the excitement of the Motor Watch. The sparkling chrome spokes connect to a chrome rim to form an authentic miniature steering wheel. A vinyl band with chrome buckle enhances the beauty of the watch. The jeweled Swiss movement is shock-resistant, with an unbreakable main-spring, polished and finished chrome case, and stainless steel back.



Only \$24.95

(Plus \$1.00 for handling, shipping, and insurance)

ONE YEAR UNCONDITIONAL GUARANTEE



Kit 682 UK
ONLY \$89.50
 Student Price
 \$79.50

Wired 682WT
ONLY \$121.50
 Student Price
 \$109.00

Seven pounds P.P. Insured

NEW, IMPROVED CONAR MODEL 682 INTEGRATED CIRCUIT

TV PATTERN GENERATOR

- EXCLUSIVE Digital Integrated Circuits
- EXCLUSIVE Four Crystal-Controlled Oscillators
- Completely Solid-State
- Color Amplitude Control
- IC Regulated Power Supply
- Modulation Adjustment
- TV Station Sync and Blanking Pulses
- Ten Patterns
- Red, Blue and Green Gun Killers
- Compact, Lightweight, Portable

You can pay much more, but you can't buy more exclusive and up-to-date features than CONAR engineers have built into the new Model 682 TV Pattern Generator. CONAR is first with digital integrated circuits and four crystal-controlled oscillators. Compact and portable, the 682 weighs less than five pounds. Peak accuracy and stability are ensured by cool all-solid-state circuitry and IC regulated power supply. The 682 incorporates a wide range of test patterns, including single and multiple vertical bar, horizontal bar and crosshatch patterns—all with horizontal lines only one raster line thick, as well as a standard ten-bar

color pattern. The most modern and versatile color generator on the market, the 682 incorporates 25 semiconductors: 12 digital integrated circuits; 6 2N3692 transistors, 6 silicon diodes and an IC voltage regulator. Oscillators include 189 kHz timing generator, 3.56 MHz offset color subcarrier, 4.5 MHz sound carrier and 61.25 MHz rf carrier (channel 3). Until now, no commercially available color generator has offered so many quality features in a single instrument. You get TV station quality composite video signals. All this, plus CONAR's low prices, make the 682 the absolute tops in dollar-for-dollar value.

SPECIFICATIONS

OUTPUT: RF only; low impedance; approximately 50,000 microvolts into 300-ohm tuner; 100% modulated carrier—composite video. **Crystal-controlled oscillators:** 189-kHz timing oscillator; 3,563.795-kHz offset color subcarrier oscillator; 4,500-kHz sound carrier oscillator; 61.25-MHz rf carrier oscillator. **Modulation:** single dot; single cross; single vertical line; single horizontal line; full dot pattern; full crosshatch pattern; full vertical line pattern; full horizontal line pattern; keyed rainbow color pattern; blank raster. **Power Requirements:** 120 volts ac, 1.0 watt. **Regulated Power Supply:** Silicon diode bridge rectifier; three-terminal integrated-circuit regulator. **Semiconductor Complement:** Twelve digital integrated circuits; six Type-2N3692 npn silicon transistors; one IC voltage regulator; four silicon rectifier diodes; one modulator diode; one Type-1N914 diode. **Gun Killer Switches:** Permanently wired cable; separate red, blue and green switches; colored switches for rapid location. **Construction:** Aluminum cabinet, chassis, and panel for light weight; printed circuit board 6" X 9"; IC's in sockets. **Size:** 10" wide by 3" high by 9" deep. **Weight:** Five pounds.

New FROM CONAR . . .

Model 224

TEST ALL VACUUM TUBES WITH THIS ONE
TOP-PERFORMING PROFESSIONAL TESTER!



... INCLUDING NEW

- ✓ Nuvistors ✓ Magnovals
- ✓ Novars
- ✓ Compactrons
- ✓ Miniatures

Only \$44.80 plus postage in kit form
Shipping weight 13 lb. Parcel Post insured

- Tests the new 5-pin Nuvistor, Novar, Compactron, 7, 9, and 10-pin miniatures as well as all standard base types.
- Easy to operate.
- Separate, easy to use tube Data Manual assures fast setup.
- Accurate, double-jeweled D'Arsonval meter movement.
- Four-position, 12-lever element switches give great flexibility—safeguard against obsolescence.
- Portable yet impressive—ideal for counter use or service calls.
- Satin-finish aluminum panel with etched lettering; won't rub off. Durable case covered with leather-look fabric; removable hinged lid with snap lock.

Adapters for Testing TV Picture Tubes

70°-90° Adapter Lets you test TV picture tube in a receiver or in factory carton. Test includes cathode emission check and check for shorts between various tube elements. Price \$3.00

110° Adapter For testing the latest 110° picture tubes. *Must be used with the 70°-90° Adapter.* Price \$3.00

Catalog price

Student and Alumni Price

Kit 224UK \$49.95
Wired 224WT \$75.95

\$44.80
\$68.25

CONAR

DIVISION OF NATIONAL RADIO INSTITUTE
 3939 WISCONSIN AVENUE • WASHINGTON, D.C. 20016

CHECK ONE: Cash Order
 C.O.D. (20% deposit required)
 Select-A-Plan Order

CHECK ONE: New CONAR Account
 Add-on CONAR Account
 Re-open CONAR Account

PLEASE PRINT

Ship to another address? Give Directions here

Name NRI Student or Graduate No.

Name

Address

Address

City State Zip Code

City State Zip Code

Moved since last order?

Previous Address

City

State

1. NAME OF ITEM	2. STOCK #	3. HOW MANY?	4. PRICE EACH	5. TOTAL	WEIGHT

IMPORTANT

To speed handling, any correspondence should be on separate paper.

All prices are net F.O.B., Wash., D.C.

Please include postage for weight shown and insurance on Parcel Post orders.

Express Orders should not include shipping charges.

A 20% deposit is required on C.O.D. orders. SELECT A-PLAN ORDERS: Please complete and sign reverse side.

Thank you for your order.

Prices in the CONAR catalog and Select-A-Plan time payment privileges apply only to residents of the United States and Canada.

6. Total Cash Price For Merchandise <small>(Do not remit for items shipped Express Collect)</small>		
7. Parcel Post and Insurance		
8. 10% Cash Down Payment and Parcel Post Costs Required on New CONAR Accounts		
9. Unpaid Balance of Cash Price <small>(Items 6 & 7 less item 8)</small>		
10. Sales Tax <small>(Washington, D.C. Residents Only)</small>		
11. Unpaid Balance <small>(Amount to be financed) (Item 9 plus item 10)</small>		
12. Finance Charge <small>(See schedule on back)</small>		
13. Total of Payments <small>(Item 11 plus item 12)</small>		
14. Deferred Payment Price <small>(Items 6, 10 and 12)</small>		

Please do not write in this space

RETAIL INSTALLMENT CONTRACT & SECURITY AGREEMENT

CONAR SELECT-A-PLAN SELECT YOUR TERMS TO FIT YOUR BUDGET

CONAR FINANCIAL RATES:

STANDARD PLAN—The ANNUAL PERCENTAGE RATE is 17.75%

EXTENDED PLAN—The ANNUAL PERCENTAGE RATE is 15.50%

TO SPEED SHIPMENT

1. Complete other side of this sheet.
2. Use Select-A-Plan Schedule on the right to find your Finance Charge and your Monthly Payment.
3. Insert amount of down payment (at least 10% of total order) and other information in Payment Agreement below.
4. Sign Payment Agreement and fill in Credit Application.

IMPORTANT: When you have made three monthly payments, you can "add-on" purchases with no down payment. If you are under 21, please have the Payment Agreement and credit application filled out and signed by a person over 21. He can make the purchase for you and will be responsible for payment. If you have a CONAR account open or recently paid-in-full, just sign the Payment Agreement.

NOTICE TO THE BUYER: (1.) Do not sign this agreement before you read it or if it contains any blank space. (2.) You are entitled to a copy of this signed agreement. (3.) The Finance Charge will be waived if the unpaid balance is paid within 30 days. If paid within 60 days, the Finance Charge will be reduced by 2%; if paid within 90 days, the Finance Charge will be reduced by 1/3. Accounts extending beyond 30 days will pay up to \$3 in Credit Service Charges before the above reductions are made.

HOW TO DETERMINE THE NUMBER AND AMOUNT OF MONTHLY PAYMENTS TO REPAY THE "TOTAL OF PAYMENTS"

Use the Select-A-Plan Schedule to find out what your monthly payment is. Then divide your monthly payment into your "Total of Payments" to find out how many monthly payments you must make. The amount which is left over is your final payment. **FOR EXAMPLE,** if your unpaid balance is \$95, then your monthly payment is \$8.75 (using the Standard Plan). If your "Total of Payments" is \$104, then your monthly payment of \$8.75 divides into that number 11 times with \$7.75 left over. This means you make 11 payments of \$8.75 each, plus a final payment of \$7.75.

SELECT-A-PLAN SCHEDULE				
PLEASE CHECK ONE <input type="checkbox"/> STANDARD PLAN <input type="checkbox"/> EXTENDED PLAN				
IF UNPAID BALANCE IS	STANDARD PLAN		EXTENDED PLAN	
	Finan- cial Charge	Monthly Pay- ments	Finan- cial Charge	Monthly Pay- ments
20.01- 25.00	1.05	3.50		
25.01- 30.00	1.50	4.00		
30.01- 35.00	2.05	4.50		
35.01- 40.00	2.65	4.75		
40.01- 50.00	3.00	5.00		
50.01- 60.00	4.15	5.50		
60.01- 70.00	5.50	6.00	6.40	4.50
70.01- 80.00	7.00	6.50	8.00	5.00
80.01- 90.00	8.00	7.75	10.10	5.00
90.01-100.00	9.00	8.75	12.60	5.25
100.01-110.00	10.00	9.75	14.80	5.50
110.01-120.00	11.00	10.75	16.20	6.00
120.01-130.00	12.00	11.75	17.60	6.50
130.01-140.00	13.00	12.75	19.40	7.00
140.01-150.00	14.00	13.75	21.60	7.50
150.01-160.00	15.00	14.75	23.20	8.00
160.01-170.00	16.00	15.75	24.80	8.50
170.01-180.00	17.00	16.75	26.20	9.00
180.01-200.00	18.00	17.00	27.90	10.00
200.01-220.00	20.00	18.50	29.80	11.00
220.01-240.00	22.00	20.00	32.40	12.00
240.01-260.00	24.00	22.00	35.20	13.00
260.01-280.00	26.00	24.00	38.20	14.50
280.01-300.00	30.00	24.50	41.20	15.50
300.01-320.00	32.00	25.50	44.20	17.00
320.01-340.00	35.00	27.00	47.80	18.00
340.01-370.00	38.00	28.00	52.40	18.50
370.01-400.00	42.00	29.50	57.20	20.00
400.01-430.00	46.00	31.50	62.20	21.00
430.01-460.00	49.50	34.00	69.00	22.00

ON ORDERS OVER \$460.00 THE FINANCIAL CHARGE ON THE EXTENDED PLAN WILL BE 15% AND PAYMENTS WILL BE IN PROPORTION TO AMOUNTS SHOWN ON ABOVE SCHEDULE

PAYMENT AGREEMENT

Enclosed is a down payment of \$..... on the merchandise I have listed on the reverse side. Beginning 30 days from date of shipment, I will pay CONAR \$..... each month for months, plus a final monthly payment of \$..... Title to and right of possession of the merchandise shall remain in your until all payments have been made. If I do not make the payments as agreed, you may declare the entire balance immediately due and payable. In satisfaction of the balance, you may at your option, take back the merchandise, which I agree to return at your request. I understand that a 1% accounting charge will be added to my unpaid balance if my payments become 60 days or more in arrears. I agree that the above conditions shall apply to any add-on purchases to my Select-A-Plan account. The statements below are true and are made for the purpose of receiving credit.

DATE BUYER SIGN HERE

IT'S AS EASY AS **A - B - C** TO OPEN A CONAR ACCOUNT

PLEASE ALLOW ADEQUATE TIME FOR NORMAL ROUTINE CREDIT CHECK. ONCE YOUR CREDIT IS ESTABLISHED, ONLY YOUR SIGNATURE IS NEEDED TO ADD ON PURCHASES

WHERE DO YOU LIVE?

PRINT FULL NAME Age:

HOME ADDRESS CITY STATE ZIP CODE

HOME PHONE HOW LONG AT THIS ADDRESS

() OWN HOME () RENT RENT OR MORTGAGE PAYMENTS \$ PER. MO.

WIFE'S NAME MARITAL STATUS () MARRIED () SINGLE

..... NUMBER OF DEPENDENT CHILDREN

PREVIOUS ADDRESS HOW LONG?

WHERE DO YOU WORK?

YOUR EMPLOYER POSITION

EMPLOYER'S ADDRESS MONTHLY INCOME \$

..... Street City State HOW MANY YEARS ON PRESENT JOB?

PREVIOUS EMPLOYER HOW LONG?

..... Name Address

WIFE'S EMPLOYER MONTHLY INCOME \$

..... Name Address

WHERE DO YOU TRADE?

BANK ACCOUNT WITH () CHECKING

..... Street City State () SAVINGS

CREDIT ACCOUNT WITH () LOAN

..... Street City State

CREDIT ACCOUNT WITH TOTAL OF ALL MONTHLY PAYMENTS INCLUDING CAR \$

..... Street City State

CONAR offers...

THE GLOB

A new concept in speaker design



Only \$36.95 per pair

The GLOB speaker has an eight-inch duo-cone speaker with whizzer cone. It is housed in rigid polyurethane foam coated with polyester resin for a glossy rock-like effect.

- Virtually indestructible
- Ideal for Teen-Ager's Rooms
- Highly Decorative
- Nothing Else Like It

SPECIFICATIONS:

Frequency range: 40 to 17,500 hertz. Impedance: 8 ohms. Power handling: up to 22 watts. Weight: approximately 4 pounds each. Dimensions: 11" high by 11" wide by 9" deep.

Order Now from CONAR

NEW! *BK* MODEL HV-32 PROBE

Measures up to 30,000 volts
with 2% accuracy!



For fast, accurate, safe high-voltage measurements up to 30,000 volts. Extremely lightweight for ease in handling, yet very rugged. Built-in overload capability. Tracking accuracy, $\pm 2\%$ of full scale. Reading accuracy, 2% at 25 kv. Meter movement includes self-shielded bar magnet. Housing is anti-static treated. Knife-edge pointer and large numbers for ease of reading. 1.75" probe tip for reaching under corona cap.

Stock No.32PB **\$29.95** Weight 2 pounds
Parcel Post Insured

NRI JOURNAL
3939 Wisconsin Avenue
Washington, D.C. 20016

MR WILLARD F VELLINE
1322 S 14 1-2 ST
FARGO ND 58102

25923 G

Second-class
postage paid
at Washington, D.C.
and additional entry