

nri journal

FEBRUARY 1964



35 Cents

In this issue:

**TV DISTRIBUTION
FUNDAMENTALS**

**ELECTRONIC
FLASHING SIGNAL**

**BINARY NUMBERING
TECHNIQUES**

**LOW VOLTAGE
RELAY OPERATION**

**REMOTE LAMP
MONITOR**

**DECIBELS AND
SOUND**

SAVE BY
BUYING
FROM

CONAR

DIVISION OF NATIONAL RADIO INSTITUTE



CONAR SIGNAL GENERATOR

*easy calibration—
accurate within 1%*

Uses Hartley-type oscillator circuit with six separate coils and capacitors. All coils are carefully pre-aligned and double-checked before shipment. High output simplifies signal injection for rapid alignment and trouble shooting on transistor and tube receivers. Covers 170kc to 60mc in six ranges, with harmonic frequency coverage over 120mc. Ideal as marker for TV alignment. Single cable for all outputs—no need to change leads when switching from 400-cycle audio to modulated or unmodulated R.F. Tuning dial features planetary drive with 6:1 ratio for greater accuracy and elimination of backlash.

Kit (280UK) \$24.⁹⁵ Assembled (280WT) \$35.95
\$2.50 down, \$5.00/mo. \$3.60 down, \$5.00/mo.

From CONAR New TOUCH CONTROL LAMP KIT

with amazing Dynaquad* electronic switch

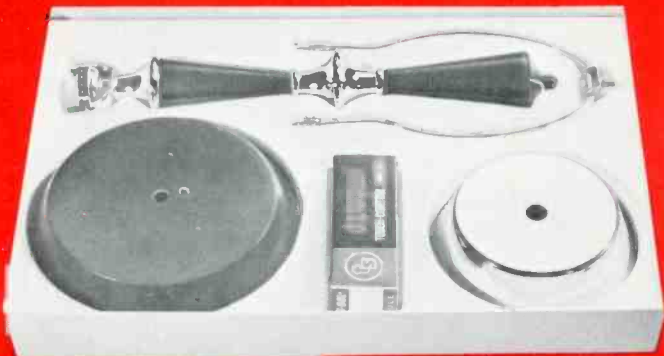

TOUCH...IT'S ON! TOUCH...IT'S OFF! Build your own polished walnut and brass conversation piece! New Touch Control Lamp Kit contains all parts, except shade and bulb, plus complete instructions. Easy to assemble, fun to use. No fumbling for an ordinary switch. Touch the base to turn it on, touch the column to turn it off.

*A trademark of Tung-Sol Electric Inc.

SPECIAL PRICE FROM CONAR **\$16.⁹⁹** (6UK)

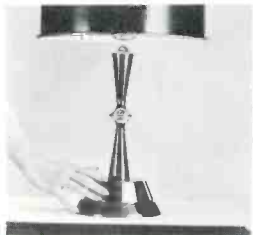

USE HANDY ORDER FORM ON PAGE 27—CASH OR TERMS

RAD-TEL'S

QUALITY

BRAND NEW TUBE SALE!

LOW, LOW PRICES--COMPARE

UP TO
SAVE 75% OFF*

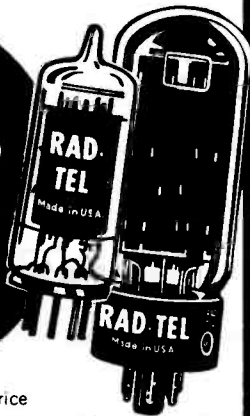

*Manufacturers Suggested List Price

ONE YEAR GUARANTEE

RAD-TEL WILL REPLACE ANY TUBE THAT DOES NOT GIVE EFFICIENT PERFORMANCE FOR 1 YEAR FROM DATE OF PURCHASE.

ONE DAY SERVICE OVER 500 TYPES IN STOCK

ORDER TYPES NOT LISTED

FREE! Send For New Tube & Parts Catalog
Send For Trouble Shooting Guide

POWER TRANSISTORS

PNP Replacements*

10-3. AF Power amplifier, auto radio. 2N155, 2N156, 2N157, 2N176, 2N234, 2N235, etc.

79¢ ea.

No. 140

500 Ma. Silicon Diode

45¢ ea.

No. 147

Epoxy Construction
Replaces top-Hat type directly.

• PIV 450 Volts max. 1.3 ma.
• AC - RMS input. 130V

10-36. Hi Power stud Type 2N173, 2N174, 2N441, 2N442, 2N443, DSS01, DSS03, DSS04.

1.39 ea.

No. 141

LOW POWER AF TYPE DRIVER OUTPUT NO. A22..... 39¢

LOW POWER RF MIXER & IF NO. A23..... 49¢

RAD-TEL TUBE CO. TV, RADIO AND HI-FI

DEPT. NR 55 CHAMBERS STREET, NEWARK, NEW JERSEY 07105

TERMS 25% deposit must accompany all orders, balance C.O.D. Orders under \$5 add \$1 handling charge plus postage. Orders over \$5 plus postage. Approx 8 tubes per 1 lb. Subject to prior sale. No C.O.D.'s outside continental U.S.A.

Fast, Dependable service - Selling direct by mail for over 16 years

RAD-TEL Tube Co. Total Tubes \$ _____
Dept. NR Total \$ _____
55 Chambers Street Part(s) \$ _____
Newark, New Jersey 07105 Postage \$ _____
Grand Total \$ _____

ENCLOSED IS \$ _____ Please rush order.

Orders under \$5.00 - Add \$1.00 handling charge - plus postage.

FREE! Send FREE Tube and Parts Catalog
 Send FREE Trouble Shooting Guide

NAME _____

ADDRESS _____

CITY _____ ZONE _____ STATE _____

EACH TUBE ATTRACTIVELY BOXED & BRANDED RAD-TEL

Qty.	Type	Price	Qty.	Type	Price	Qty.	Type	Price	Qty.	Type	Price
024	.79	6A8	.87	6K6	.63	12CU5	.58				
1AX2	.62	6AV6	.41	6S4	.52	12CU6	1.06				
1B3	.79	6AW8	.90	6SA7GT	.99	12CX6	.54				
1DN5	.55	6AX4	.66	6SH7	1.02	12D4	.69				
1G3	.79	6AX5	.74	6SJ7	.88	12DE8	.83				
1J3	.79	6BA6	.50	6SK7GT	.95	12DL8	.88				
1K3	.79	6BC5	.61	6SL7GT	.84	12DQ6	1.04				
1R5	.77	6BC8	1.04	6SN7	.65	12DS7	.84				
1S5	.75	6BE6	.55	6SQ7GT	.94	12DT5	.76				
1T4	.72	6BF5	.90	6T4	.99	12DT7	.79				
1U5	.65	6BF6	.44	6T8	.85	12DT8	.78				
1X2B	.82	6BG6	1.70	6U8	.83	12DW8	.89				
2AF4	.95	6BH8	.98	6V6GT	.54	12DZ6	.62				
3AL5	.46	6BJ6	.65	6WA	.61	12E05	.62				
3AU6	.54	6BJ7	.75	6W6	.71	12EG6	.62				
3AV6	.42	6BK7	.85	6X4	.41	12EK6	.62				
3BC5	.63	6BL7	1.09	6X8	.80	12EL6	.50				
3BN6	.75	6BN6	.74	7A8	.68	12EZ6	.57				
3BU8	.78	6BQ6	1.12	7AU7	.65	12FR6	.66				
3BY6	.58	6BQ7	1.00	7EY6	.75	12FA6	.79				
3BZ6	.56	6BU8	.70	7Y4	.69	12FM6	.50				
3C86	.56	6BX7	1.11	8AU8	.90	12FR8	.97				
3C56	.58	6BZ6	.55	8AW8	.93	12FX8	.90				
3DG4	.85	6BZ7	1.03	8B05	.60	12GC6	1.06				
3DK6	.60	6C4	.45	8CG7	.63	12J8	.84				
3DT6	.54	6C86	.55	8CM7	.70	12K5	.75				
3GK5	.99	6CD6	1.51	8CN7	.97	12L6	.73				
3Q4	.63	6CG7	.61	8CS7	.74	12SF7	.69				
3S4	.75	6C88	.80	8EB8	.94	12SK7GT	.95				
3V4	.74	6CL8	.79	8F07	.56	12SL7	.80				
4BQ7	1.01	6CM7	.69	9CL8	.79	12SN7	.67				
4C56	.61	6CN7	.70	11CY7	.75	12SQ7GT	.91				
4DT6	.55	6C88	.92	12A4	.60	12U7	.62				
4GM6	.60	6CR6	.60	12AB5	.60	12V6	.63				
5AM8	.79	6C56	.57	12AC6	.55	12W6	.71				
5AN8	.90	6C57	.69	12AD6	.57	12X4	.47				

RAD-TEL TUBE CO. NOT AFFILIATED WITH ANY OTHER MAIL ORDER TUBE COMPANY

5AQ5	.54	6CU5	.58	12AE6	.50	17AX4	.67
5AT8	.83	6CU6	1.08	12AE7	.94	17DQ6	1.06
5BK7	.86	6CY5	.70	12AF3	.73	18FW6	.49
5BQ7	1.01	6CY7	.71	12AF6	.67	18FX6	.53
5BR8	.83	6DA4	.68	12AJ6	.62	18FY6	.50
5C86	.81	6DEE	.61	12AL5	.47	19AU4	.87
5CL8	.76	6DG6	.62	12AL8	.95	19BG6	1.39
5C88	.84	6DJ8	1.21	12AQ5	.60	19EA8	.79
5EA8	.80	6DK6	.59	12AT6	.50	19T8	.85
5E8	.80	6DN6	1.55	12AT7	.76	21EX6	1.49
5J6	.72	6DQ6	1.10	12AU6	.51	25AX4	.70
5T8	.86	6DT5	.81	12AU7	.61	25C5	.53
5U4	.60	6DT6	.53	12AV6	.41	25CA5	.59
5U8	.84	6DT8	.94	12AV7	.82	25CD6	1.52
5V6	.56	6EA8	.79	12AX4	.67	25CU6	1.11
5X8	.82	6E85	.73	12AX7	.63	25DN6	1.42
5Y3	.46	6E88	.84	12AY7	1.44	25EH5	.55
6AB4	.46	6E85	.77	12AZ7	.86	25L6	.57
6AC7	.96	6EM7	.82	12B4	.68	25W4	.68
6AF4	1.01	6E18	.75	12BD6	.50	32ET5	.55
6AQ5	.70	6EV5	.75	12BE6	.53	35C5	.51
6AH4	.81	6EW6	.57	12BF6	.60	35L6	.60
6AH6	1.10	6EY6	.75	12BH7	.77	35W4	.42
6AK5	.95	6FG7	.69	12BK5	1.00	35Z6	.60
6AL5	.47	6FV8	.79	12BL6	.56	36AM3	.36
6AM8	.78	6GH8	.80	12BQ6	1.16	50B5	.69
6AQ5	.83	6GK5	.61	12BR7	.74	50C5	.53
6AS5	.60	6GK6	.79	12BV7	.76	50EH5	.55
6AT6	.49	6GN8	.94	12BY7	.77	50L6	.61
6AT8	.86	6H6	.58	12BZ7	.86	70L7	.97
6AU4	.85	6J5GT	.51	12CN5	.56	117Z3	.85
6AU6	.52	6J6	.71	12CR6	.67	807	.75

Features

TV DISTRIBUTION FUNDAMENTALS	RUSS PAVLAT 5
ELECTRONIC FLASHING SIGNAL	A. J. MOLINARA 12
BINARY NUMBERING	G. B. STUMP 18
LOW VOLTAGE RELAY OPERATION	FLOYD KEITH 26
REMOTE LAMP MONITOR	RONALD L. IVES 29
DECIBELS AND SOUND	RUSS PAVLAT 34

Departments

SEMICONDUCTOR REVIEW	JOHN POTTER SHIELDS 15
DEVICE OF THE MONTH	R. C. APPERSON, JR. 23
WHAT WOULD YOU HAVE DONE?	GEORGE D. PHILPOTT 32
ALUMNI NEWS	38
COVER	30

OLIVER READ
Editor and Publisher

ELIZABETH MORALES
Managing Editor

J. B. STRAUGHN
Technical Editor

T. E. ROSE
Editor - Alumni News

RICHARD STANCHIK
Art Editor

Editorial

It has been my pleasure to have been your editor during the period of transition from NRI News to our new monthly NRI Journal. Your many letters of praise have been most encouraging to our entire staff and have made it possible for us to design the magazine so that its contents include topics of interest to the great majority of its readers.

We, here at NRI, are fortunate to have qualified technicians and editors capable of producing the Journal each month to best serve your particular needs. This team will, under the editorship of William Dunn, take over the production of the Journal next month.

I have resigned as your editor to assume the responsibilities of editor of Electronic Capabilities, and am returning to New York.

Your new editor, Bill Dunn, is well qualified to take over the administration of the Journal in addition to his duties as Director of Education for NRI. It is gratifying to leave the future of the Journal in such capable hands.



Oliver Read

TUNER REPAIRS

Includes **ALL** parts (except tubes)...
ALL labor on **ALL** makes for complete overhaul.

\$9.50

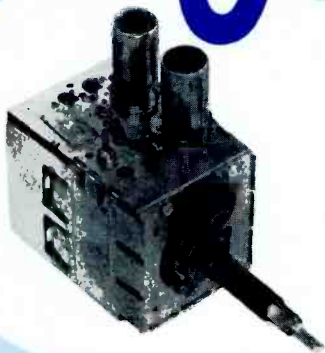

FAST, 24-HOUR SERVICE
with **FULL YEAR WARRANTY**

Sarkes Tarzian, Inc., largest manufacturer of TV and FM tuners, maintains two completely-equipped Service Centers, offering fast, dependable tuner repair service. Tarzian-made tuners received one day will be repaired and shipped out the next. More time may be required on other makes. Every channel checked and realigned per manufacturer's specs. Tarzian offers full, 12-month guarantee against defective workmanship and parts failure due to normal usage. Cost, including all labor and parts (except tubes), is only \$9.50 and \$15 for UV combinations. No additional costs. No hidden charges. You pay shipping. Replacements at low cost are available on tuners beyond practical repair.

Always send TV make, chassis and Model number with faulty tuner. Check with your local distributor for Sarkes Tarzian replacement tuners, parts, or repair service. Or, use the address nearest you for fast factory repair service.



SARKES TARZIAN, INC.
TUNER SERVICE DIVISION

Dept. 200
537 South Walnut St.,
Bloomington, Indiana
Tel: 332-6055

Dept. 200
10654 Magnolia Blvd.,
North Hollywood, Calif.
Tel: 769-2720

You'd expect an FM booster designed by Blonder-Tongue to be something special...

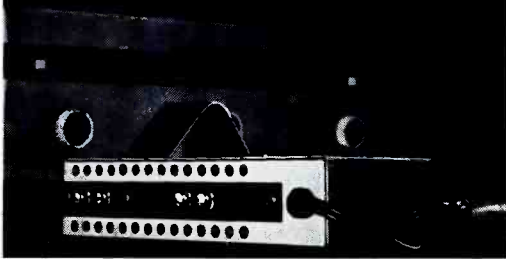

this one is

The Blonder-Tongue FMB STEREOBOOSTER is special because it increases signal strength 8 times (18 db gain), while keeping noise down to the bare minimum (noise figure 3.8 db) . . . because it eliminates distortion caused by phase and amplitude variation and by impedance mismatch (low VSWR) . . . because it doesn't overload when there are strong local stations present . . . and because it does all these things steadily and reliably. But since Blonder-Tongue is the company with the *most* experience in TV and FM signal amplification, how could you expect any less? A must for multiplex stereo, and for mono in weak signal areas . . . installed quickly & easily anywhere indoors. Improves reception with an FM antenna, your TV antenna, or a home-made twinlead dipole. List **\$21**

engineered and manufactured by

BLONDER-TONGUE

9 Alling St., Newark, 2 N. J.

CANADIAN DIVISION: BENCO TELEVISION ASSOC., LTD., TORONTO, ONT.

HOW TO BIND YOUR NRI JOURNALS

Sir:

It seems that some of our readers are having a problem with the new Journal since it will not fit the NRI Binder. I have this problem in hand and I find that it works very well. I cut my Journals as shown below with a pair of side cutters. 1/4" deep and 1/4" wide is enough of a cut.

Lutrell Mainous
B33-C22
N. Las Vegas Nev.



Editors Note: We tried it here at NRI and it works fine. It is the solution our readers have been looking for.



TV DISTRIBUTION FUNDAMENTALS

BY RUSS PAVLAT

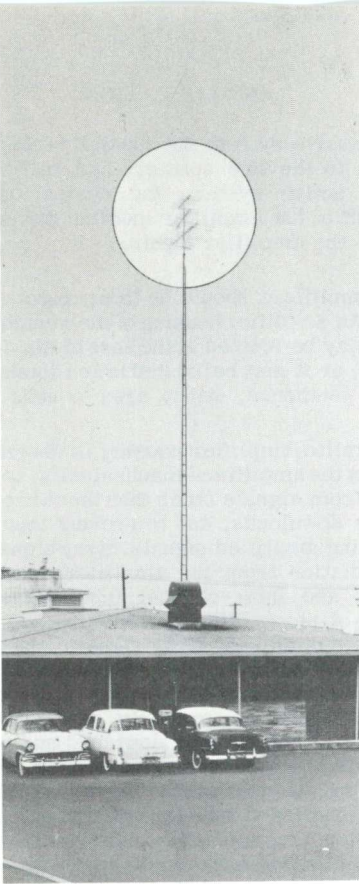

Illustrations Courtesy Blonder-Tongue Laboratories

The availability of more television channels, the impracticality of installing a separate antenna for each occupant of a multi-room or apartment dwelling, and the desire for neater appearing buildings have all contributed to the installation of television distribution methods making programs available to each building unit from a common antenna system.

A typical distribution system is shown in Fig. 1 and consists of one or more roof antennas, distribution amplifiers, line splitters, distribution lines or cable (which may be in or out of conduit) and wall outlets.

In some high signal areas, it is possible to install a passive (without amplifiers) distribution system where the inherent losses are overcome by the signal from a high gain antenna, and a satisfactory signal is present at the wall outlets. The operating costs of a passive system are comparatively less than an active system. The initial cost of a passive system may be more or less than an active system, and if higher, may be justified to the owner on the basis of lower operating costs.

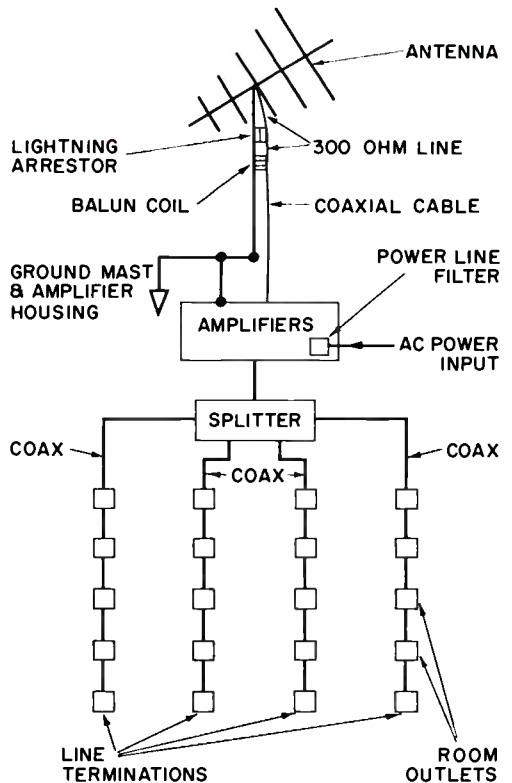

FIG. 1. Typical television distribution system.

The higher cost of a passive system is almost entirely due to the high gain directive antennas required.

The design of the antenna system depends on the strength of the signals in a particular area. In very strong signal areas and particularly if all the desired signals are from the same direction, a broadband VHF or UHF antenna may be used. In most areas, separate cut-channel VHF or UHF Yagi antennas, tuned to individual channels, are desirable. Bow-ties operate satisfactorily on UHF and a parabolic UHF antenna will do an excellent job on one or more weak UHF signals. The extra gain and directivity of good antennas give better performance with less noise pick-up, less ghosts and less inter-channel interference. The extra gain of Yagi antennas sometimes permits the use of a passive system, when a broadband antenna would require distribution amplifiers.

Physically, the antenna system should be solidly constructed, with pipes, towers and guy wires of sufficient strength and number to support adequately the weight of multiple antennas. Masts and towers should be well grounded. All downleads should be well supported to avoid twisting, swaying and vibration.

Electrically, antenna location and orientation is important to pick up the proper signal and to eliminate unwanted signals and ghosts. A field strength meter (preferably with an AGC circuit which can be disabled for small signals) is a valuable tool for properly locating and orienting an antenna system. Fringe VHF signals are usually found in horizontal layers, while fringe UHF signals may be located by adjustment of the antenna in both the horizontal and vertical planes. The highest point may not be the most desirable. Grounded or ungrounded screens may be used to eliminate or direct a signal.

Lightning arrestors should be located as close to the antenna as practical. These are normally 300-ohm units which attach directly to a mast or tower using the metallic part of the mast or tower (which has been properly grounded) as a ground return.

Because of the rapid weathering of 300-ohm line, a minimum amount should be used in outdoor parts of the installation. A weatherproof balun coil to convert from 300-ohm twinline to 75-ohm coaxial cable (such as RG-11-U or RG-59-U) should be installed as close to the lightning arrestor as possible. Coaxial downlead is weather resistant, can be fastened directly to masts and towers, and does not pick up local noise or interference.

In a passive system the coaxial cable is continued to the line splitters and wall outlets. In an active system, the coaxial cable is brought to the amplifier location for connection to the amplifier inputs.

The amplifiers should be in a protected location. An amplifier housing of the weatherproof type may be located at the base of the mast or tower, or it may be located in an adjacent elevator penthouse, utility area or attic space.

A metallic amplifier housing is desirable to protect the amplifiers mechanically, to shield them from signals other than those brought in by the downleads, and to prevent them from radiating amplified signals. Stray signal input or radiation from the amplifiers can cause ghosts and inter-channel interference because of phase differences among the signal from the downlead, stray signal at the amplifier location, and any amplified signal which might be radiated back to the antenna. The housing must be properly ventilated and grounded. The coaxial downlead and the coaxial distribution cable, with their inherent shielding, can protect the system against the above mentioned interference and automobile ignition noise, noise from neon or fluorescent lights, electric motors and power lines. Coaxial cables are automatically grounded securely in the amplifier housing at the amplifier inputs through the coaxial fittings. The amplifier chassis is grounded through the metal mounting screws.

A filter on the AC power line to the amplifier housing should always be installed to prevent stray signals from entering the housing and to prevent radiation of an amplified signal via the power lines. Ordinarily, 120-volt AC power can be made available at the amplifier housing location. If power requirements are low, duplexers may be used on the coaxial cable allowing simultaneous transmission of the TV signal and power to an amplifier. When duplexers are used, the 120-volt AC line is stepped down to 24 or 48 volts AC and the cable is used to transmit the 24 or 48 volts to the amplifier location, where it is transformed back to 120 volts for operating of an amplifier. The actual potential on the coaxial cable must be chosen carefully to insure conformance to all applicable codes. Isolation transformers, rather than auto-transformers must be used to avoid the presence of potentials dangerous to the users on the cabling.

Since the loop resistance of RG-11-U coax and 300-ohm twinline is about 2 ohms per hundred feet, and the loop resistance of

RG-59-U is about 4 ohms per hundred feet, current flow losses at relatively high power levels make duplexing impractical at power levels above about 50 watts for any appreciable cable length. Actual losses can be simply calculated for a given system (prior to installation) from cable lengths and power requirements to see if duplexers are practical. For example, if a 72-watt load were to be served by a 24-volt duplexed line, the current would be 72 divided by 24 or 3 amperes and the loss over 100 feet of 300-ohm or RG-11-U line (2-ohms loop resistance per 100 feet) would be 3 multiplied by 2 or 6 volts or 25% of the voltage transmitted. When the 24 volt line is transformed to 120 volts the 25% loss of 6 volts at 24 volts becomes 25% of 120 or 30 volts loss leaving only 90 volts to operate the equipment. If a 48-volt duplexed line were used with the same 72-watt load, the current would be 1.5 amperes, the loss 3 volts, or 6.25% and the available voltage after transformation would be 112.5 volts. These calculations assume a 100% power factor and no transformer losses, but the error from these assumptions is small enough to neglect for practical purposes.

The object of the amplifiers in the system is to provide a mixed signal for distribution containing all desired channels at balanced levels. Signal strengths of from 1000 to 2000 microvolts are desirable at wall outlets. Channel voltages must be balanced within 25% to avoid cross-modulation, "ride-through", and overload.

Where signal strengths from the antennas are relatively uniform, a broadband amplifier such as shown in Fig. 2 may be used to amplify all signals simultaneously. These units are available for VHF low band (channels 2 through 6) or as complete VHF broadband amplifiers (channels 2 through 13). Since the distribution losses are more for high band signals than they are for low band signals, separate level controls for high band and low band should be included on all VHF broadband amplifiers to allow gain and balance adjustments

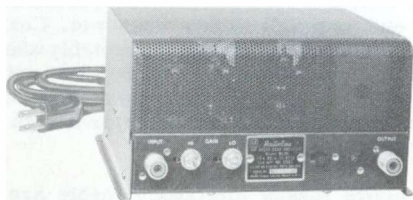

FIG. 2. Broadband amplifier with separate low band and high band controls.

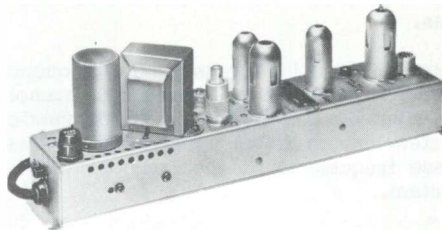

FIG. 3. High gain single channel amplifier.

of low band and high band channels separately. Some broadband amplifiers include "tilt" controls to compensate for increased attenuation by the distribution system of the higher VHF channels.

One or more strong signals mixed with weaker signals at the input of a broadband amplifier tends to cause inter-channel interference and tends to make the amplifier insensitive to the weaker signals, with the result that since the stronger signals are amplified more than the weaker signals, an already poor balance is made worse.

Selective equalizers which attenuate a particular channel or channels to balance the signal level of all channels at the input of a broadband amplifier can sometimes be used advantageously.

To avoid interference from signals on adjacent channels prior to amplification, careful shielding of the amplifier inputs from each other and the use of adjacent channel traps may be required. Here again, coaxial cable with its inherent shielding is an aid in avoiding interference.

For best results, when one or more signals are weak, separate amplifiers tuned to each channel desired, are recommended. These units should have separate gain controls, outputs which can be connected together to form a mixed output, and automatic gain control to compensate for line voltage changes and variations in input signal levels. A typical single channel amplifier is shown in Fig. 3.

Where adjacent channel interference causes extreme difficulties, converters are available to change VHF low band signals to VHF high band signals and vice versa, allowing optimum selection and spacing of signals on the distribution system. Crystal controlled converters are advised for stability. These intra-band VHF converters are also useful when the relatively higher losses of VHF high band distribution become excessive, and it is practical to convert a VHF high band signal to a VHF low

band signal which can be distributed with less loss.

Because of the high transmission frequencies used, UHF channels 14 through 83 cannot be distributed effectively on a conventional system due to the very high signal losses at these frequencies in the components of the system.

To distribute UHF effectively, it is necessary to convert the UHF signal to an unused VHF channel on either the low or high band. Very stable crystal controlled converters are advised, and are normally located in the amplifier housing with the rest of the amplifying equipment. If possible, adjacent channel operation should be avoided; if it is necessary, adjacent channel traps should be included. Gain sufficient for direct connection of the converter to a distribution system. After conversion, with proper level control, the converted signal should be amplified and distributed by a broadband or single channel amplifier system.

BRANCHING

Branching or line splitting should be done as closely as possible to the amplifier outputs, and the branching should provide a logical distribution pattern consistent with the physical layout of the system. Some broadband amplifiers incorporate multiple outputs at the proper impedance, thus automatically providing a number of distribution lines. If a 75-ohm line is split into two 75-ohm lines and one-half of the original signal is directed into each of the two lines, we would expect a 3 db forward power loss in signal. Actually, the line splitter itself introduces some slight additional loss and a 4 db forward calculation is conservative and in common usage. Similarly, one line split into four lines is a theoretical 6 db forward power loss, with 8 db being commonly used for calculation. Line splitters may or may not give isolation between band lines, and manufacturers commonly make both kinds, with isolation varying from 15 to 20 db between lines. Isolation between branch lines is desirable to prevent noise and interference generated in one line of the system from spreading to the rest of the system.

Occasionally, in addition to induced electrical noises on a line, a set will radiate oscillator frequency back into the system, causing diagonal lines or herringbone patterns to appear on other sets. In a carefully designed system, there is considerable justification for using branching to isolate parts of the system, not only to accommodate the physical layout, but to provide multiple distribution lines with a relatively small number of

sets per line. This allows rapid system servicing by allowing the serviceman to isolate trouble by elimination. Line splitters are commonly manufactured to provide two or four split lines and may be cascaded as needed.

DISTRIBUTION LINE

Since steel construction, wire lath, water pipes, and conduit for electrical services tend to interfere with TV signals and signal distribution, the use of ordinary 300-ohm line between the amplifiers and the wall outlets normally results in serious losses, noise, and interference. Ordinary 300-ohm line in conduit loses its TV signal or has it seriously reduced in a relatively short distance. Ordinary 300-ohm line in plastic conduit may lose its signal rapidly if metallic conduit, water pipes, wire lath, or steel construction is adjacent to the plastic conduit. Shielded 300-ohm is satisfactory for relatively short distances in or out of metallic or plastic conduit, but it losses are high, it is subject to more interference than 75-ohm coaxial cable, and its size and stiffness tend to make it difficult to install.

Typical losses per 100 feet of various lines is as follows:

	50 mc	100 mc	500 mc	1000 mc
300-ohm twinlead,	1.0 db	2.0 db	3.5 db	5.0 db
ribbon tubular lead,				
open line				
RG-11-U coax,	1.5 db	3.0 db	5.0 db	8.0 db
75-ohm				
RG-59-U coax,	3.0 db	6.0 db	10.0 db	15.0 db
75-ohm				

CABLE LOSS CHART

It is noted that, while the non-coaxial lead losses are less, these values are for dry open air, with at least six inches of spacing from metal objects along the entire length of the line. 300-ohm line losses increase as the line approaches metal. Twinline or ribbon lead losses increase about six times when wet, tubular lead losses increase about two times when wet, and open line losses increase about one and one-half times when wet. Coaxial cable losses do not change appreciably when in conduit or adjacent to metal or when wet. In designing a system, consistent characteristics of materials enables better design and operation.

The above losses for coaxial cable are for cables with standard insulating materials. Cables with polyfoam and other special insulations are available, and these have from 15 to 25% less loss.

Coaxial cable is superior in weather resistance, will pick up less noise and interference, and will limit radiation of the amplified signal effectively. Coaxial cable must be installed in accordance with all applicable codes. In making the choice between RG-11-U and RG-59-U, remember that although RG-11-U has about one-half the loss of RG-59-U, it is also about twice the diameter and weighs about twice as much. Coaxial cable is, however, relatively weak mechanically, and if not in conduit, should be supported about every twelve inches on horizontal runs and about every 24 inches on vertical runs. Stretched cable, whether due to stretching during installation or sagging with age, changes in impedance, and losses are higher especially on high band VHF.

Since line attenuation varies with frequency, a very long distribution line will attenuate signals unevenly, typically causing unsatisfactory reception of VHF high band signals while VHF low band signals may be O.K. A broadband amplifier or amplifiers with individual high band and low band gain controls and tilt controls placed along the distribution line as needed can be used to correct this difficulty.

OUTLETS

Flush wall outlets as shown in Fig. 4 are ordinarily installed in a standard size electrical outlet box. Impedances of 300 ohms and 75 ohms are standard, with the 300-ohm outlet having terminals for twinline and the 75-

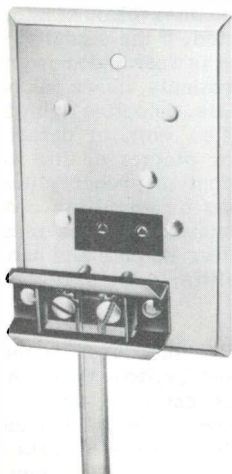

FIG. 4. Typical room outlet.

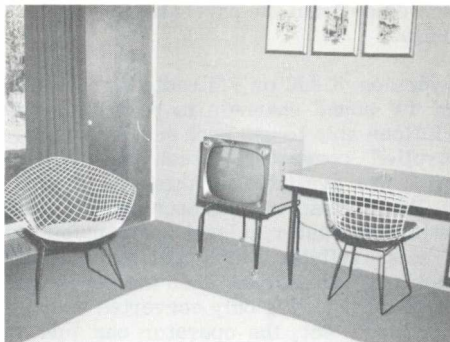

FIG. 5. Typical motel room TV installation.

ohm outlets accepting a coaxial plug. When using 300-ohm twinlead it is necessary only to connect the 300-ohm set antenna terminals to the 300-ohm wall outlet, but when using coaxial cable it is necessary to use a matching transformer at the set terminals to match the 75-ohm coaxial cable to the 300-ohm set input. Coaxial cable has the advantage of providing shielding from the wall to the set. In the presence of a strong local signal, an unshielded line from the wall outlet to the set may pick up enough signal to cause leading ghosts, since this signal arrives slightly ahead of the distributed signal. Where all signals are weak, requiring high gain antennas and high amplification, the likelihood of leading ghosts is minimized and 300-ohm line from the wall to the set is usually satisfactory. Normal forward loss in a good wall outlet is 0.6 db, with isolation of the set from the line at from 15 to 20 db. The isolation minimizes interference and interaction among sets. Fig. 5 shows a typical motel room installation and emphasizes the neat appearance of a good job.

Since the shield of the coaxial cable is grounded, it can be dangerous to connect an AC-DC set to a distribution system. A .001 or .002 mfd, 600-volt capacitor should always be installed in series with each antenna lead from the AC-DC set to the wall outlet.

The end of each distribution line must be terminated properly to prevent line reflections which cause ghosts and smear. Normally, 75-ohm, 1/2-watt carbon resistors are used on the end of each line to maintain the proper impedance, provide absorption and to prevent reflections.

Impedance matching throughout the entire system is very important. Impedance mismatching causes interference, loss of signal, ghosts and smear. These are particularly objectionable in distribution of color signals since smear, for example, appears in a dif-

ferent color from the part of the picture being smeared.

Conversion of AM or FM radio signals to unused TV sound channels is possible for installations able to use such services. Crystal controlled converters, such as shown in Fig. 6, are available for this type of operation. While these units do not normally eliminate picture raster, at least one manufacturer has sets available which will automatically "black out" the screen when the set is tuned to a channel having only converted sound. In an ordinary set, the operator can turn the brightness control to minimum and usually reduce the raster to a satisfactory light level.

CALCULATIONS

Normally, systems would be designed so that the set farthest away from the antenna would receive sufficient signal, with the rest of the sets closer to the antenna receiving stronger signals. If this cannot be done without overloading the sets closer to the antenna, then the system is adjusted for satisfactory reception at the sets closer to the antenna, and broadband line amplifiers are used to raise the signal of the farther sets.

Signal strength as read by a field strength meter is expressed in microvolts. Systems gains and losses are expressed in decibels, since decibels can easily be added or subtracted for each component. In calculating system gains and losses, normally it is necessary to convert from microvolts to decibels at the amplifier input and from decibels to microvolts at the farthest set.

For example, if we have a channel 2 signal with four split lines (8-db loss per line in splitter) 300 feet of RG-59-U coaxial cable, 10 tap-offs on the line, and 15-db isolation from each tap-off to the set, the decibel loss to the farthest set would be 8 from the splitter, 9 from the coax (3.0 db/100 ft) 6 from the tap-offs (0.6-db tap-off) plus 15 for the set isolation or a total of 38 decibels loss. If the signal at the amplifier input terminals is 2000

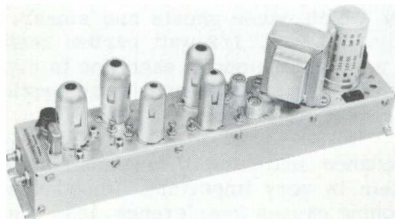

FIG. 6. Unit to convert radio signal to unused TV sound channel.

microvolts, in order to have 2000 microvolts at the set terminals, 38 decibels of gain on channel 2 would be required. If the signal at the amplifier input terminals was 1000 microvolts and 2000 microvolts was required at the set terminals, then 38 plus 6 or 44 decibels of gain on channel 2 would be required. An increase of 6 decibels doubles the voltage, a loss of 6 decibels halves the voltage. Similarly, an increase of 20 decibels increases the voltage 10 times, a loss of 20 decibels reduces the voltage to one-tenth.

The chart in Fig. 7 shows these and other pertinent values of decibels voltage ratios.

For gains (+db) multiply the signal by the voltage ratio. For losses (-db) divide the signal by the voltage ratio.

TROUBLESHOOTING

For troubleshooting TV distribution systems, a selection of tubes, a vacuum tube voltmeter, a continuous tuning field strength meter and a lightweight portable TV set will suffice for the majority of troubles. The field strength meter is used to determine the signal strengths at any point on the system and can isolate and pinpoint the difficulties involving signal strength.

The vacuum tube voltmeter will measure AGC voltages, power supply voltages, line voltages and can be used to check for opens, shorts, or high resistance faults due to water in cable.

The TV set permits actual picture checks at various locations from the antenna to the farthest set tap-off and is probably the most useful of the tools mentioned. Poor signal-to-noise ratio and inter-channel interference are readily detected. If the signal strength is low, or the picture is weak and snowy at the amplifier input terminals, check for corroded antenna terminals, defective lightning arrestor, defective balun coil, or defective or open cable. A poor picture or low signal at the amplifier output is probably due to aged or damaged tubes or amplifier components or poor connections. When the picture is O.K. at the amplifier outputs and poor at the set, check line splitters, lines, terminations, and connections.

Ghosts may be introduced at the antenna or may be caused by defects in the system. If ghosts are present at the amplifier input, reorient the antenna, or use grounded screens to eliminate reflections. Ghosts or smear at the set locations indicate impedance mismatching, poor or open line or bad equipment connections.

DECIBELS	0	6	12	18	20	26	32	38	40
VOLTAGE RATIO	1	2	4	8	10	20	40	80	100
DECIBELS	46	52	58	60	66	72	78	80	100
VOLTAGE	200	400	800	1000	2000	4000	8000	10,000	100,000

FIG. 7. Typical decibel - voltage ratios.

60-cycle AC interference will cause dark moving horizontal bars. Check tubes, filter capacitors, and proximity of distribution lines to strong AC fields. Check for installation of new AC equipment, especially if complaint shows up after the system has been operating successfully for some time. A single stationary black and white bar, or extreme picture distortion is usually caused by signal overload at the set. If it occurs on a single channel, readjust levels of system, if it occurs on all channels or only on a particular set use attenuators at the tap-off to reduce the signal level to the set.

Sparking at electrical devices, fluorescent or neon lights, and ignition noises cause horizontal light streaks at random through the picture. Check grounds, equipment connections and line terminations, if a recently developed trouble, look for unsuppressed new equipment noises.

Odd picture patterns, herringbone, diagonal lines and venetian blind patterns are probably caused by rf interference from FM stations, adjacent channels, local TV set oscillator radiation fed back into the lines, or line amplifier oscillation. Use FM traps or adjacent channel traps at line amplifier inputs, adjust or repair line amplifiers if they are oscillating, locate and repair defective receiver feeding local oscillator interference into line, or increase isolation of this particular receiver from line. If any of this interference is being brought in on the powerline of the set showing these patterns, use a good line filter to remove rf from powerlines at this point.

If one or more channels are riding through on other channels, this is probably due to the imbalance of signals in the system. Adjust voltage balance of all signals within 25% using any available level or tilt controls, or use selective attenuation to bring the level of stronger signals closer to the level of other signals. If this interference continues when all signals are balanced, use selective channel traps at amplifier inputs to limit the passband being amplified.

A break in outside coaxial cable which allows water to enter the cable results in power leakage and impedance changes. The water will migrate along the cable for considerable distances on both sides of the break. Replace at least 10 feet of cable on either side of an outside break which has been subject to moisture conditions. All outside coax connections should be taped and sprayed with plastic to weatherproof them. Since these materials deteriorate rapidly out of doors, they should be checked frequently. Plastic spray on 300-ohm line outside connections will reduce corrosion difficulties.

A capable radio and TV technician will find the installation and maintenance of commercial television distribution systems a profitable addition to his other service work. The principles involved in the operation of these systems and the troubles encountered are closely allied to those in set repair. Regular preventive maintenance schedules can be promoted and are a definite advantage to a system owner, and work on the system can very easily lead to maintenance and repair work for set owners within the building.

With a basic knowledge of these components, their purposes, and operation, further opportunities in the electronics field are available to those who wish to advance.



"OH! HECK! GOSH! GRACIOUS!
HEAVENS! SHUCKS! MERCY!"

Build This:

ELECTRONIC FLASHING SIGNAL



AN INTERESTING PROJECT FOR THE EXPERIMENTER

BY A. J. MOLINARA

The electronic flasher described herein will furnish a constant means of attraction to any one who happens to be in the immediate vicinity. It could be used as a distress signal on the highway, or for that matter, for any other type of signal. Another interesting trick application for the device is to place the flashing bulb in your coat lapel with two small wires extending from it to the control unit that would be concealed in a coat pocket. This should be a good source of amusement and consternation, provided of course, you are not picked up and shipped to the booby hatch.

However, as far as the author is concerned, it serves as a little playtoy when placed on the desk at the office, and of course it has resulted in numerous comments of "What is it?" .. "What does it do?" Aside from the above ramifications, the electronic flashing signal is designed around an unusual circuit which will prove both interesting and educational to anyone engaged in transistor circuitry. With a little ingenuity, there is no doubt that the experimenter can find other uses in which the circuit configuration can be used for other applications.

It is possible to construct a flashing signal by simply using a 90-volt battery, resistor, capacitor, and neon light, in a standard charge and discharge type of circuit. However, the circuit described, will operate on only 2

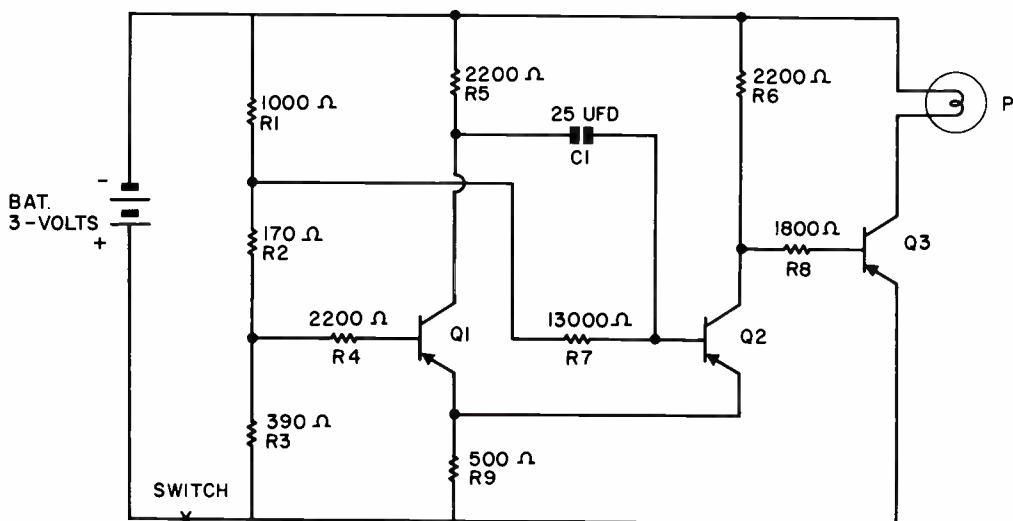

FIG. 1. Schematic of a transistorized circuit used to produce flashes at the rate of about one per second.

penlite cells and a regular type pilot bulb which will emit much more light than the neon bulb.

Fig. 1 shows a schematic of the transistorized circuit used to produce flashes at the rate of about one per second. Capacitor C1 and resistor R7 determine the flashing rate. The frequency can be increased by reducing the value of either the capacitor or resistor or both. Similarly, the frequency may be lowered by increasing these values. The bulb P is a type 49 pilot lamp which is rated at 2 volts and 60 ma. Q1 and Q2 are type 2N1305 transistors which list at only \$.61 each. Q3 is a type 2N1377 transistor which lists at \$1.50. The 2N1377 transistor was selected to handle the current drawn by the pilot bulb. C1 is a 25 μ fd 25-volt capacitor which happened to be available. A 3-volt capacitor in this position will be entirely satisfactory. The resistors are all rated at 1/2 watt.

A description of the circuit operation is as follows: - Resistors R1, R2, and R3 allow the correct bias voltages to be applied to the bases of Q1 and Q2. If capacitor C1 were omitted and the circuit energized, transistor Q1 would be in a non-conducting state and Q2 would be in a conducting state due to the more negative bias applied to its base. Now, if capacitor C1 were connected and the circuit energized, Q2 will again conduct initially. However, the emitter to base current of Q2 will flow through R9, emitter to base junction, C1, and R5. This current will flow until capacitor C1 becomes charged. The base of Q2 now assumes a more positive potential, which is sufficient to drive the transistor to cutoff. This picture is much easier to visualize if we consider a voltage divider network consisting of R5, C1, Q2 emitter to base junction, and R9. We will then see that when C1 is charged, the base of Q2 is more positive than it was when the effective bias was obtained from the junction of R1 and R2 with the capacitor out of circuit. In effect, the positive side of C1 is closer to the positive battery potential than is the junction of R1 and R2.

When Q2 emitter current is cut off, there is a reduced voltage drop across R9 which is common to both transistors. This reduced voltage drop causes the emitter of Q1 to become more positive in relation to its base, and because of this forward bias, the transistor will begin to conduct. As soon as this happens, C1 will discharge through Q1, the rate of discharge being determined mostly by the value of R7. The circuit is then ready for the next cycle.

Let us now consider the circuit operation relating to Q3. When Q2 is conducting, its emitter to collector is substantially a short cir-

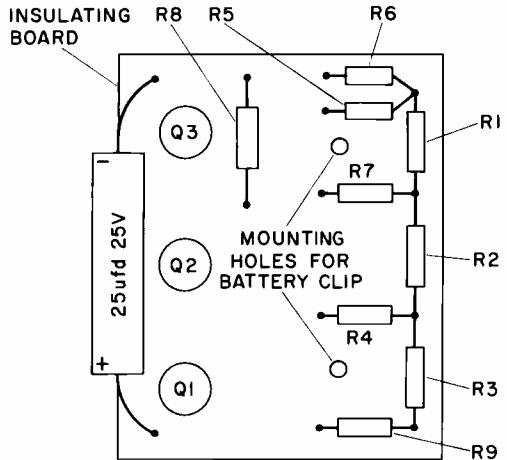

FIG. 2. Layout used by author.

cuit. This condition places the base of Q3 near the positive side of the battery supply. This positive potential is sufficient to prevent conduction in Q3 and the bulb is therefore not lit. Now when Q2 is cut off, its emitter to collector can be considered as an open circuit. When this happens, the base of Q3 is effectively connected to the negative side of the battery supply through R6 and R8. This forward bias causes Q3 to conduct, thereby lighting the bulb P during the period of conduction.

The whole control unit may be built on 1/16 inch thick insulating board measuring 2 x 2-1/2 inches. Any type of reasonable insulating material may be used such as bakelite, masonite, wood, etc. Also, any type layout can be followed as the circuit is not critical. The author used a piece of epoxy glass sheet which was drilled with small holes to receive the various component leads. Fig. 2 shows the layout. The component leads are fed through holes in the board, and bent over on the other side to anchor in place. Fig. 3 shows the opposite side of the board where all the wiring is done. Make sure that a heat sink is used when soldering to the transistor leads.

Longnosed pliers will prove adequate for this purpose. Fig. 4 shows the method used to mount the 2 cell battery clip that holds the 2 penlite cells, and also the simple switch used to turn on the power. When the screw is turned in to contact the frame of the battery clip (which is connected to the battery) the power is connected to the circuit through the screw and nut. Of course, a standard type switch may be used. The pilot bulb may be soldered carefully to the 2 wires indicated, or else a regular socket may be employed. The whole unit may be housed in a small box with a rub-

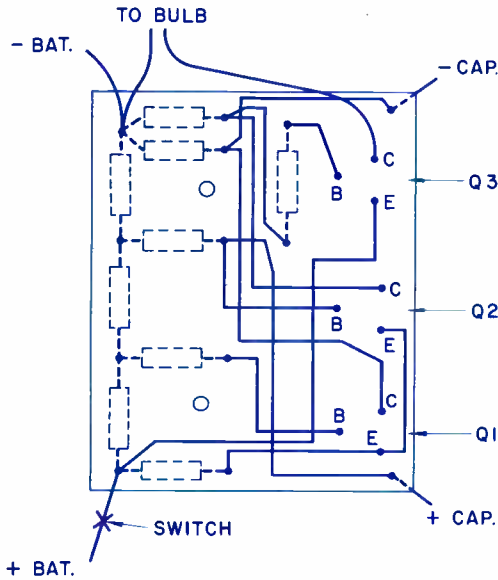

Fig. 3. Opposite side of board where wiring was done.

ber grommet to receive the pilot bulb. If desired, the switch described can be made easier to handle by cementing a knob or nut on the screw, using epoxy cement.

The trigger circuit can be checked readily by connecting a voltmeter across R6. The voltmeter pointer should rise and fall, indicating that the circuit is functioning. If for any reason, trouble is experienced, resistors R2 and R3 may be varied, but it is unlikely that this will be necessary.

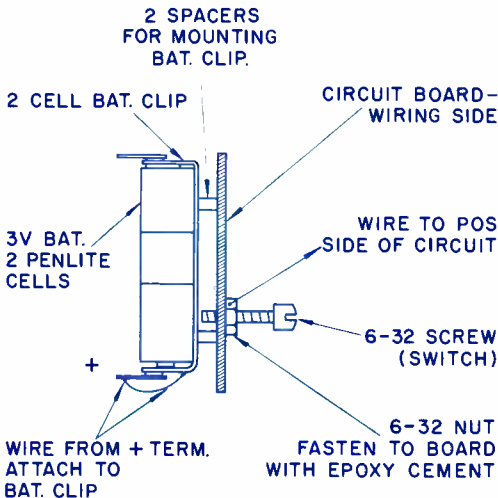

FIG. 4. Method of mounting the 2 cell battery clip.



BOOKS

MATHEMATICS FOR ELECTRONIC AND ELECTRICITY

By the Staff of National Radio Institute

This concise volume was designed for the technician and technical student. It is taken from course material of National Radio Institute.

The text begins with a review of arithmetic and takes the reader by steps through algebra, trigonometry, Boolean Algebra, and the binary numbering system. Each topic is related to its electronic application and sample problems are included to help you learn and to retain the knowledge gained.

Published by John F. Rider, Inc., 116 W. 14th St., New York 11, N. Y. 250 pages. Soft Cover \$3.95.

HOW TO BUILD TINY ELECTRONIC CIRCUITS

By Morris Moses

The hobbyist, experimenter and service technician will find this book the answer to "how to make it smaller." It explains "miniaturized" electronics and will teach readers to think "small."

It is written in a simple, interesting style and contains hundreds of schematics, illustrations and photographs.

Published by Gernsback Library, Inc., 154 W. 14th St., New York. 191 pages. \$5.85 clothbound; \$4.15 paperback.

TRANSISTOR IGNITION SYSTEMS HANDBOOK

By Brice Ward

This is a comprehensive study of the newly developed ignition systems which mark the entry, on a large scale, of semiconductors in the automotive field. Material covered includes the need for ignition systems, spark plugs, information on the main components of the system - power transistors and zener diodes, various practical and commercial systems, installation and servicing techniques.

Published by Howard W. Sams and Co., Inc., 4300 W. 62nd St., Indianapolis 6, Ind. 128 pages. Soft Cover. \$2.50

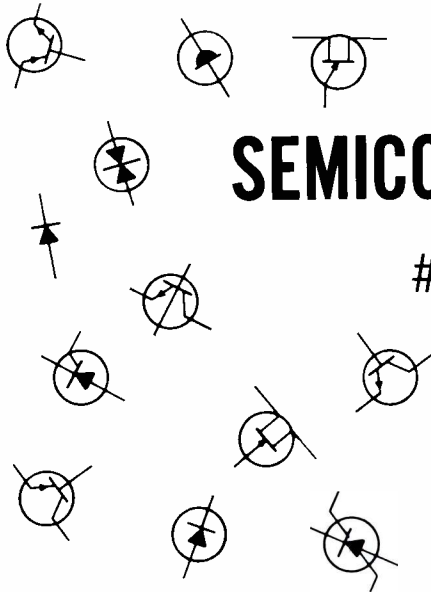

SEMICONDUCTOR REVIEW

5 PHOTOCELLS

BY

JOHN POTTER SHIELDS

This month, we're going to look at semiconductor photocells . . . those little devices that are finding their way into many commercial and household devices such as headlight dimmers, TV contrast and brightness controls, and street light switches. Unlike earlier gas and high vacuum photocells, these new semiconductor units offer small physical size, ruggedness and a wide variety of physical configurations. Since semiconductor photocells are in general low to medium impedance devices, they lend themselves well to transistor circuitry . . . a feat almost impossible with the older gas and high vacuum photocells.

TYPES OF PHOTOCELLS

Photocells may be divided into three basic categories; photoemissive, photoconductive (sometimes termed photoresistive), and photovoltaic.

The operation of the photoemissive photocell is based on the property of certain substances such as cesium oxide, whereby they will release free electrons when exposed to light. In practice, the photoemissive material is applied as a coating to a concave cathode placed opposite a centrally located anode wire; these two elements being enclosed in a high vacuum as shown in Fig. 1. When photons of light strike the cathode, electrons are released from its surface and are attracted to the positively charged central anode wire. The number of electrons emitted from the photocathode, and hence current flow through the

tube, will be a function of the intensity of light striking the cathode.

The photocathode and anode may also be placed in an inert gas-filled envelope, thereby forming a "gas photocell." The addition of the gas greatly increases the cell's sensitivity due to the fact that electrons released by the photocathode collide with the gas molecules on their way to the anode. These "electron-gas molecule" collisions release negative ions which are also attracted to the positively charged anode, magnifying the current flow through the tube. This effect is sometimes termed "gas amplification."

The photomultiplier tube is an interesting variation of the basic photoemissive cell. Offering sensitivities up to a million times greater than the conventional high vacuum photoemissive photocell, the photomultiplier tube makes use of a phenomenon known as secondary emission.

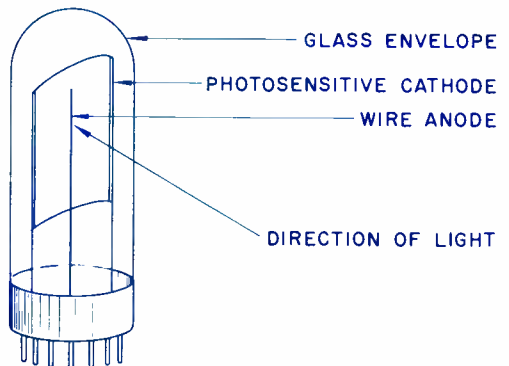

FIG. 1. Structure of a typical photoemissive photocell.

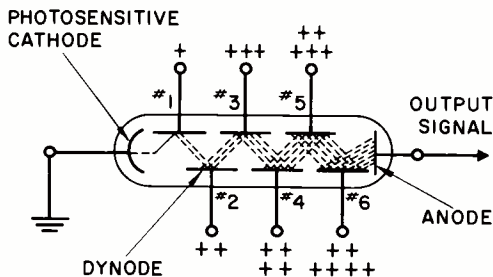

FIG. 2. The basic operation of the photomultiplier tube.

Fig. 2 illustrates the basic operation of the photomultiplier tube. In operation, electrons emitted from the photocathode by the application of light are attracted to dynode No. 1 which is maintained at a positive potential with respect to the cathode. It is at this first dynode that the process of secondary emission begins. Due to the composition of the dynode, every electron striking it will release two or more additional electrons. This "electron multiplication" is analogous to a billiards "break," where the cue ball knocks free additional balls from the cluster.

The additional electrons emitted from dynode No. 1 are in turn attracted to dynode No. 2 which is maintained at a positive potential with respect to dynode No. 1. The same electron multiplication takes place at dynode No. 2 . . . each electron striking it and releasing additional electrons.

This process is repeated at each of the photomultiplier's dynodes with the result that the number of electrons reaching the tube's anode from the final dynode will be perhaps a million times as great as those released by the photocathode. This of course explains the high sensitivity of the tube.

Photomultiplier tubes are used extensively in nuclear radiation scintillation counters where their great sensitivity can detect the minute flashes of light caused by subatomic particles striking the phosphor screen.

PHOTOCONDUCTIVE CELLS

Largely responsible for the increasingly wide application of photocells to domestic and commercial applications, the photoconductive cell offers much greater sensitivity than either the gas or conventional high vacuum photocells, as well as being considerably more rugged than either of these two types.

Basically, a photoconductive cell may be considered a resistor whose resistance is a function of the light striking it; the resistance de-

creasing with increasing illumination. Depending upon the particular type of photoconductive cell, the resistance ratio from total darkness to full rated illumination may be 1,000,000 to one or greater. Again, depending upon the type of cell, the maximum dark resistance may range from the tens of thousands of ohms to well into megohms, with corresponding full illumination resistance values in the range of from 25 ohms or so, up into the low thousands of ohms.

One of the major advantages of photoconductive cells is that they can operate a relay directly without the need of an intervening amplifier. Fig. 3 shows such a setup where the relay and photoconductive cell are simply connected in series and placed across a source of DC. When not illuminated, the cell's resistance is high and not enough current can flow through the circuit to energize the relay. Upon illumination, the cell's resistance drops and the current increases to a point sufficient to close the relay.

Recent developments have provided photoconductive cells which can handle considerable power, thus making possible their direct control of loads without relays, and simplifying circuitry even further.

As shown in the accompanying photograph, photoconductive cells are available in a wide variety of physical configurations, each intended for a specific application. The large, circular cell (second from the left) is typical of the "high power" cells suitable for the direct load control.

The two basic substances used in the active area of photoconductive cells are cadmium sulfide (CdS) and cadmium selenide (CdSe).

Cadmium sulfide cells are used in applications involving actuation by visible light sources as they offer the greatest sensitivity in this region. In fact, it is possible to fabricate a CdS cell which will closely match the color sensitivity of the human eye.

Cadmium selenide cells on the other hand, are most sensitive to wavelengths in the red

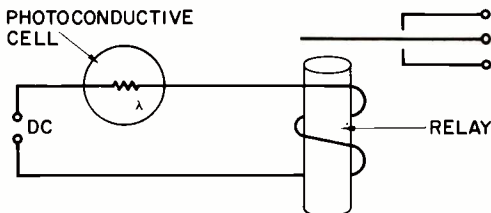

FIG. 3. The relay and photoconductive cell connected in series and placed across a source of DC.

and infrared regions. Also, the speed of response (length of time required to effect a resistance change after the application of illumination) is considerably faster in CdSe cells.

In the manufacture of a photoconductive cell, the active material, either CdS or CdSe, is deposited as a thin film between the two terminals of the cell. Quite often, the active material is deposited in the form of a grid to lengthen the resistance path between terminals. This technique is especially effective in obtaining the higher resistance values.

An interesting use of photoconductive cells is shown in Fig. 4. A CdS cell, designed especially for this application by the Clairex Corp., is used to control the shutter speed of the new Polaroid Land Model 100 camera.

In operation, light falling on the CdS photocell determines its resistance, and hence the charging time of the R-C timing circuit. If high illumination falls on the cell, its resistance will drop; causing rapid charging of the timing circuit. This in turn results in quick actuation of the two stage transistorized trigger circuit (Q1 and Q2) thereby giving a fast shutter speed. At low illumination, the cell's resistance increases, resulting in a longer timing circuit charging time and a consequent slowing down of shutter speed.

Other applications for CdS and CdSe cells include television receiver contrast and brightness controls, light actuated potentiometers, aids for the blind and many others.

PHOTOVOLTAIC CELLS

Photovoltaic cells represent the third major

category of photocells. The photovoltaic cell has the property of generating an electrical potential when exposed to light, the amount of potential developed being a function of illumination intensity.

Selenium and silicon represent the two basic materials from which photovoltaic cells are fabricated. Of these two materials, silicon provides the greater conversion of input illumination to electrical energy output; offering efficiencies as high as 15%.

Although less efficient than silicon cells, selenium cells are considerably less expensive and are excellent for such applications as automatic exposure devices for cameras, headlight dimmers and lighting controls. A very useful feature of selenium cells is that they can be fabricated into a wide variety of shapes for specific applications.

Silicon photovoltaic cells sometimes called "solar cells," find their greatest application in military and space projects where they are used to convert solar radiation directly into usable amounts of electrical energy. In this application they generally charge nickel-cadmium storage cells which can then release the electrical energy during periods when the cells are not illuminated.

Both selenium and silicon photovoltaic cells contain P-N junctions . . . the same as do semiconductor diodes and transistors. Without going into a great amount of theory, the basic operation of the semiconductor photovoltaic cell is as follows. Near the cell's P-N junction, holes from the P-type material combine with free electrons from the N-type material, resulting in the P-type material

CONTINUED ON PAGE 30

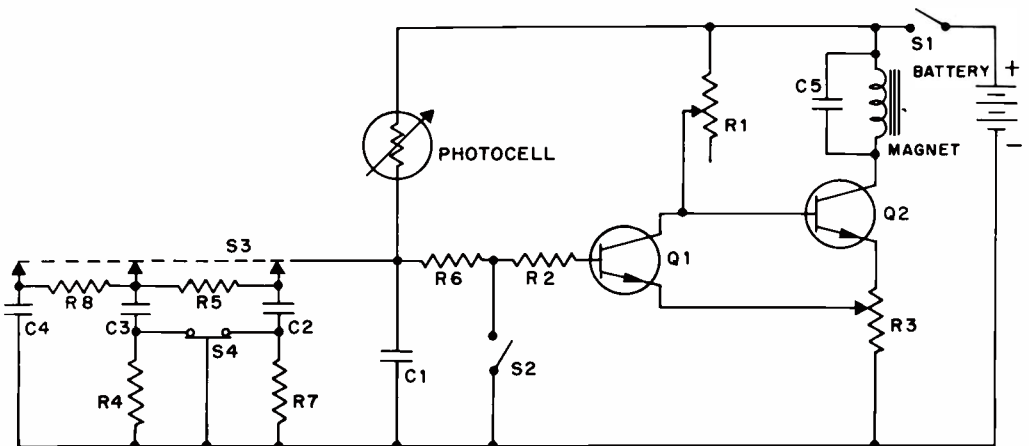

FIG. 4. A CdS cell used to control the shutter speed of the new Polaroid Land Model 100 camera.

UNDERSTANDING COMPUTERS REQUIRES
 A KNOWLEDGE OF BINARY TECHNIQUES

BINARY NUMBERING

1010
 1001
 1000
 111
 110

101
 100
 11
 10
 1

BY G. B. STUMP

Counting and other simple operations with numbers are commonplace in our daily activities, yet few people are aware of the possibility of other methods of counting. Indeed there can be an infinite number of methods, or systems, all following the same basic rules but each having a different number of symbols. The most common system, of course, is the decimal system with which everyone is familiar. To understand how other systems can be developed consider an example of the decimal system, the watt-hour meter illustrated in Fig. 1. The first, or right hand, dial records the individual units to a total of ten while the second dial records the number of complete revolutions of the first. Complete revolutions of the second dial are recorded by the third, and so on for as many positions as desired.

Thus, when a dial or position is filled one unit is shifted into the next higher position, this being the procedure of all positional systems of numbering. Consider now a watt-hour meter requiring only eight units to completely fill each position. Just as in the decimal system the absence of single units will be indicated by a zero in the first position. Thus, when exactly eight units have entered the first position one unit will be shifted into the second position with no single units remaining and the dials will indicate (1) (0). While the total num-

ber of symbols required is eight it is seen that the eighth symbol is the zero, whereas in the decimal system the tenth symbol is the zero. Just as in the decimal, or base ten, system where ten complete revolutions (or $10 \times 10 = 10^2$) is indicated by (1) (0) (0), in the base eight system eight complete revolutions of the first dial (or $8 \times 8 = 8^2$) is indicated by (1) (0) (0). The significance of expressing the number in the previous example in exponential or powers form is important in that each dial or position represents an exponent or power of the base number. In the base ten system, for example, the first dial will record the number of ones, the second dial the number of tens, the third dial the number of 100's and so on, while in the base eight system the first dial will record the number of ones, the second dial will record the number of eights, the third dial the number of 64's and so on. Following this same basic procedure it is possible to form a system of numbers using any base.

It should be noted that if the base is greater than ten, new symbols are introduced as seen in Fig. 2 where a comparison is made between the decimal, or base ten system, and systems of base two, eight, and twelve. The base two, or binary system, is the simplest of all inasmuch as it requires only two symbols.

To understand the operation of the binary system consider again the example of the watt-hour meter where each dial has just two symbols, the (1) and the (0) as illustrated in Fig. 3. If initially all dials, or positions, are indicating zero an input of one unit will advance the first or right hand dial to (1) and an input of two units will advance it to (0) completing one revolution. Each time a dial completes a revolution it will advance the following dial



FIG. 1. A watt-hour meter in the decimal numbering system.

one place and two complete revolutions of a dial will advance the following dial two places or one complete revolution. It should be remembered that a dial advances immediately following the occurrence of a zero in the previous dial with no advancement following the

Decimal or base 10 number	Binary or base two number	Base eight number	Base twelve number
0	0	0	0
1	1	1	1
2	10	2	2
3	11	3	3
4	100	4	4
5	101	5	5
6	110	6	6
7	111	7	7
8	1000	10	8
9	1001	11	9
10	1010	12	a
11	1011	13	b
12	1100	14	10
13	1101	15	11
14	1110	16	12
15	1111	17	13
16	10000	20	14
17	10001	21	15
18	10010	22	16
.			
64	1000000	100	54
100	1100100	144	84
144	10010000	220	100

FIG. 2. A comparison of four different numbering systems.

occurrence of a one in the previous dial. In Fig. 2, if the decimal numbers are taken as a tabulation of the total input, then the base two numbers will be the dial indication of the binary watt-hour meter. If in the previous example the system of dials is replaced with a series of lamps and the necessary controlling circuitry, the condition of each lamp will be an indication of the total input. That is, a (1) will be indicated by an "on" lamp and a (0) will be indicated by an "off" lamp. As will be shown it is the condition of the controlling circuitry, whether "on" or "off", that is of importance in the actual counting operation, the use of lamps or other indicating devices being limited to the indication of the results. Circuits that exhibit "on-off" characteristics can be readily designed and so in electronic computing and counting operations the binary numbering system is used extensively.

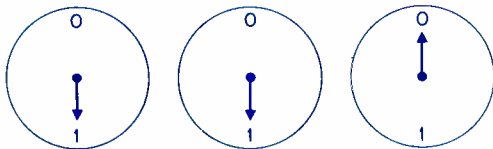

FIG. 3. A watt-hour meter in the binary numbering system.

The fundamental circuit of all counting operations is the bistable multivibrator in which a conducting or on state represents a (1). Fig. 4 represents the requirements of such a circuit. It should be noted that whereas circuitry today

utilizes transistors and other semiconductors extensively most basic circuits and logic were developed using vacuum tubes. The examples and discussion presented here will consider semiconductors exclusively and will be concerned with fundamental requirements rather than with design details. In the circuit of Fig. 4, if transistor Q1 is conducting, the very low collector voltage will force the base of Q2 to remain negative, holding Q2 off. With Q2 nonconducting its high collector voltage will be applied to the base of Q1 maintaining Q1 in the conducting state, and as expected these conditions will exist until a signal is applied to either transistor causing it to change state.

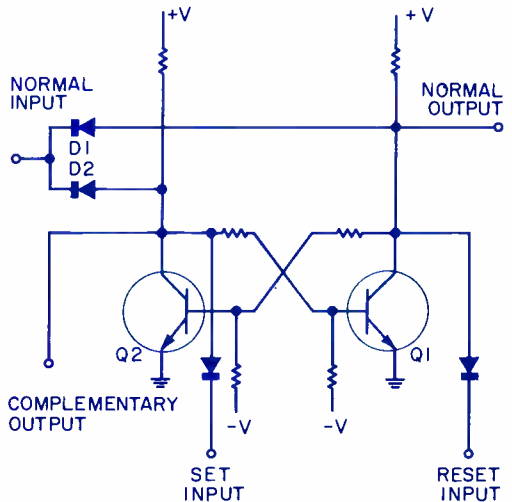

FIG. 4. The basic bistable multivibrator circuit. In the configuration shown the binary number (1) is indicated when Q1 is nonconducting and the binary number (0) is indicated when Q1 is conducting.

If a negative pulse is applied to the input it will be directed by diode D2 to the base of transistor Q1 turning it off. The increasing voltage at the collector of Q1 will be coupled to the base of Q2 turning it on. This sequence will be repeated for each input pulse, or trigger, the two transistors alternately conducting and nonconducting. If in the circuit of Fig. 4 the output, or collector voltage change, of Q1 is directed to the input of a second identical counter then it can be seen that for an input of two negative triggers to the first counter there will be one negative trigger to the second counter. The diagram and typical waveforms of Fig. 5 illustrate how this can be extended indefinitely, each counter dividing by two the output of the previous counter. The final condition of all counters will be an indication in binary form of the total number of input triggers. The actual design of a triggered multi-

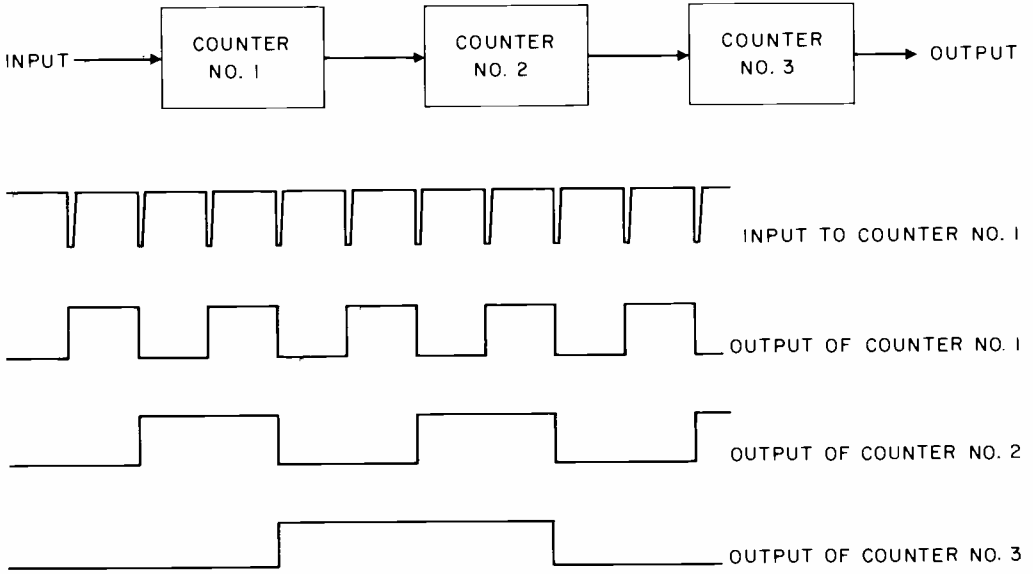

FIG. 5. The input and output of three identical counters.

vibrator can take many forms; the supply voltage can be of either polarity, the trigger can be applied to either the base, emitter, or collector and can turn a transistor on or off, the output can be taken from the collector or the emitter. Since in the circuit of Fig. 4 a negative trigger is used it will be the negative output that is used to trigger the next counter, while a positive output will not affect the following counter. A negative output is generated when a transistor is turned on, while a positive output is generated when a transistor is turned off. The complementary output is generated following the first input trigger and is frequently used as a feedback to previous stages, or can in certain configurations be

taken as the normal output. The purpose of the reset input is to insure that all counters are in the same state, each requiring two inputs for one output. The set input can be used to enter a number in a counter before the normal input is applied in special computer configurations.

A practical application of the binary multivibrator circuit is the typical electronic counter illustrated in Fig. 6. The gate generator is a series of identical counters which successively divide by two the output of the crystal oscillator. The gate pulse thus generated will be of a very precise width, having the accuracy of the crystal oscillator, and when ap-

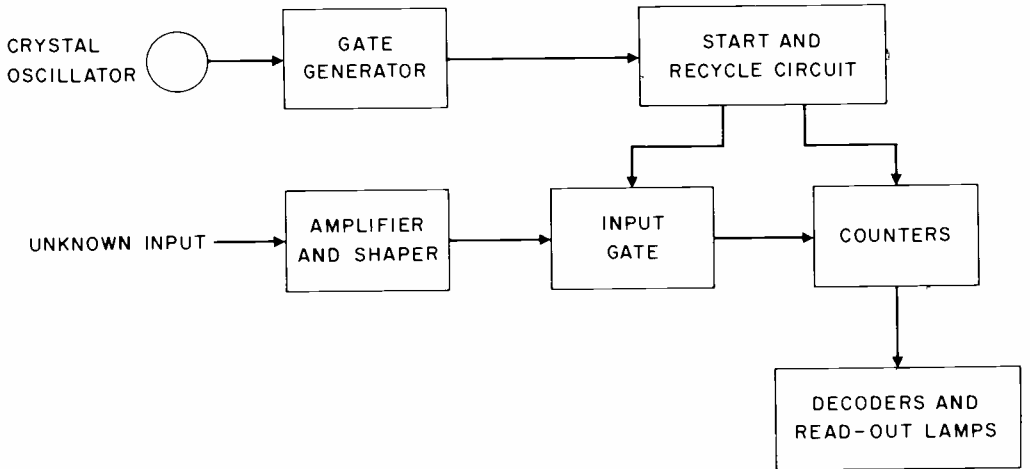

FIG. 6. A typical electronic counter circuit.

plied to the input gate will allow the unknown frequency to enter the counter. Following the counting interval, or gate time, the condition of the counters will be sampled by the decoders which convert the binary number of the counters to the more familiar decimal form which is displayed by the read-out lamps. Following the display time the start and recycle circuitry will reset all counters and initiate a second counting interval.

In counting down from the higher frequency oscillator signal it is convenient to generate a gate width of exactly one second (or 10 or 100 seconds) in order to read out directly in cycles per second. Depending upon the oscillator frequency it may not be possible to divide successively by two and arrive at exactly one pulse or gate width per second, therefore it is necessary to divide by some other number, for example 10. To understand how this division is accomplished consider a series of 4 identical counters with a signal from the fourth counter fed back to the input of the second and third as shown in Fig. 7. In this arrangement when the count reaches 8 a trigger from the collector of Q2, the complementary output, in the fourth counter will be fed back to the second and third counters which effectively increases the total count from

8 to $8+4+2=14$. An input of 2 more trigger pulses will now give one output from the fourth counter, the result being that the 4 counters have divided by 10 rather than the usual 16.

The gate pulse generated by proper division of the oscillator frequency when applied to the input gate simultaneously with the unknown input will permit the unknown to enter the counter for one second. This circuit arrangement is known as an 'and-gate' and is illustrated in Fig. 8. While there are many possible circuits that will perform this function, the essential feature is the same, namely that both inputs must be present in order for the output signal to exist. In Fig. 8 transistor Q1 will be nonconducting except in the presence of the gate width and even though the unknown signal is applied to the base of Q2 it cannot appear at the output except for the length of time that Q1 is turned on.

The decoders are a series of 'and-gates', the binary inputs to each being such as to exactly describe a particular decimal number. For example the decimal number 6 will require the binary numbers 2 and 4 but there must not be the binary numbers 1 and 8. The circuit arrangement for a decoder which will indicate the decimal number 6 is illustrated

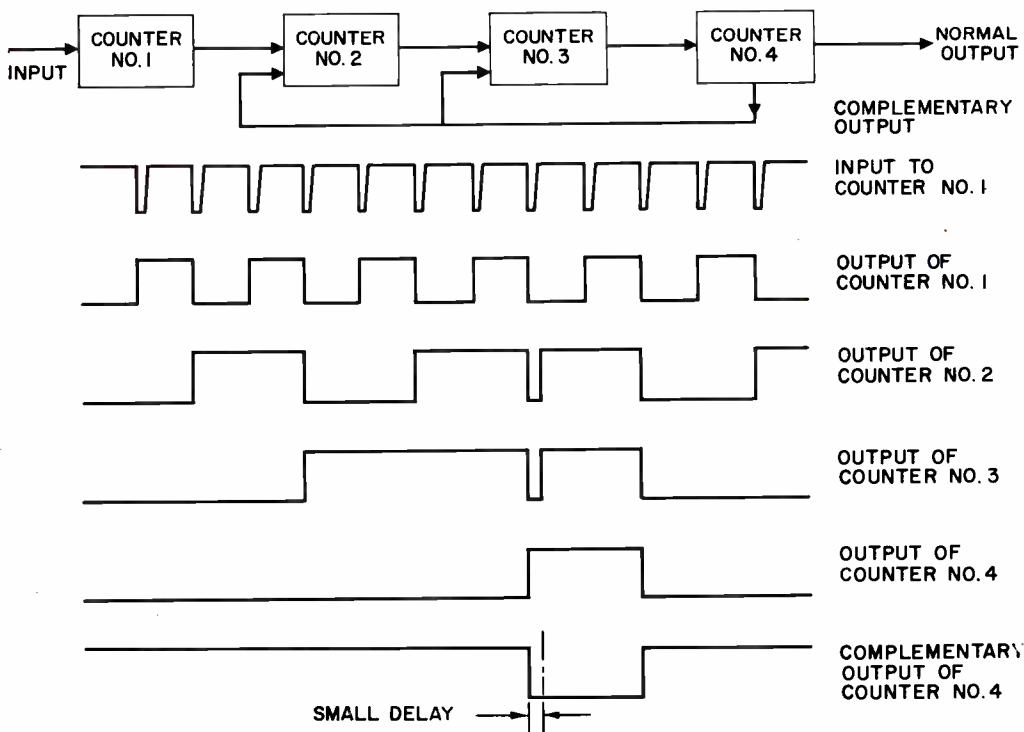

FIG. 7. Four counters arranged to divide by ten. Normal circuit behavior will afford a small delay essential to proper triggering of counters 2 and 3 by the feedback pulse.

in Fig. 9. It should be noted that there must be one 'and-gate' for each decimal number that may be indicated. Actual circuit arrangements usually accomplish the decoding and reading functions with fewer components. However, the requirements and fundamental procedures are the same. Also, the arrangement of the counters in groups of 4 to count by 10 as described previously greatly simplifies the decoding and reading operations.

The amplifier and shaper circuit is necessary in order to present to the input gate and counter a trigger of constant amplitude and shape. In counters that have high frequency capabilities, above approximately 10 megacycles per

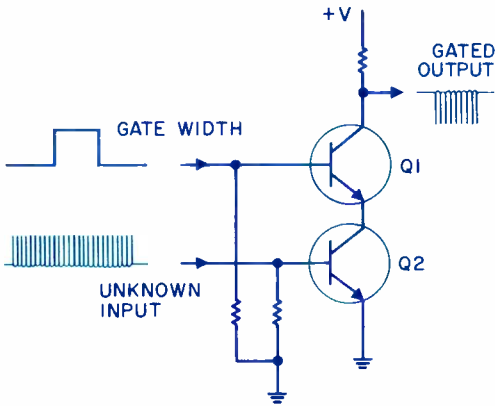

FIG. 8. A typical "And-Gate" circuit.

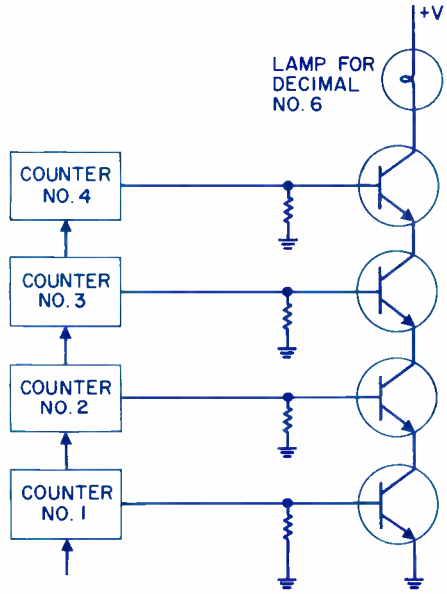

Fig. 9. Binary to decimal decoder circuit. The outputs of counters 2 and 3 have a value of 2 and 4 respectively, while the outputs of counters 1 and 4 insure the absence of the values of 1 and 8 respectively.

second, it is necessary to lower the unknown frequency effectively before it is applied to the input gate by mixing it with a known fixed frequency.

Bottle Up Your Mike

Liquor bottles and decanters come in a wide variety of sizes, shapes, and styles. Some have a historical significance (see photo), and others are just too beautiful to throw away, and some become rare collectors items. If you use your favorite bottle to support your mike you have a conversation piece in more ways than one -- you talk about it and you talk at it.

As shown in the photo, the writer's bottle had a plastic screw-cap so it was only necessary to drill a 3/8" diameter hole in the cap and fasten in an Amphenol 75-PC1M chassis unit. A threaded ring coupled the Turner mike to the unit. The writer wanted the mike cord to pass through the bottle, so he took the bottle to a glass shop to have a small hole drilled near the bottom to pass the cord.

You will have to use your ingenuity to fit your mike to your favorite bottle. With some mikes it isn't necessary to pass the cord through the inside of the bottle. **A.T.**



DEVICE OF THE MONTH

THE CHOKE

BY R. C. APPERSON, JR.

The choke is a frequency sensitive valve that impedes, or chokes out, unwanted currents and allows wanted ones to flow. Therefore, the choke does exactly what its name implies. The electronics field would be lost without this device, even though it is comprised of only iron and wire, and in some cases, just wire. The choke is used in applications that range from the filtering of DC power supplies to radio frequency circuits. A knowledge of what the choke can do is of utmost importance to the technician. After a circuit is designed and built it must be serviced. An understanding of what the engineer had in mind when the circuit was designed helps in troubleshooting a problem. We will try to cover the applications of the choke and any peculiarities that might have arisen in circuits in which we have had choke trouble.

These are the symbols found schematically to represent the choke.



One is for the iron core, which is used through the low frequency range and the other is the air core, for higher frequency applications. Since the choke and the transformer belong to the same family, their symbols are somewhat alike. A low frequency choke appears physically like a transformer, but inspection tells us that the choke has only two leads while the transformer will usually have at least four.

A division can be made in a discussion on chokes. They can be discussed in two groups, low frequency and high frequency. Why is

there a difference? The iron is the main difference, since the inductance is much, much smaller in the high frequency range. Also, the type of iron is different, due to losses encountered as frequency increases. Let's discuss first how the choke, in general, works. Next we will discuss the low frequency applications, then high frequency applications.

We know, from AC and DC theory, that the inductor in a circuit tends to resist any change in current flow, the more abrupt the change, the greater the resistance offered. The inductance of an inductor is based on the number of turns of wire and the amount of iron in the magnetic circuit. The inductive reactance, or resistance to sudden change in current flow, is a product of inductance and frequency. For a given inductance, a more sudden change in current flow is resisted by a greater amount than a lesser change. This is how the choke works. Over a wanted frequency range the inductance, even though it does resist some, will allow the currents to flow. As frequency increases, inductive reactance increases, choking out the higher frequencies. DC, as long as it stays constant, is impeded only by the DC resistance of the wire. This allows the choke to act as a block to certain AC components and let the DC go merrily on its way.

In low frequency applications, the choke is found in power supplies as either

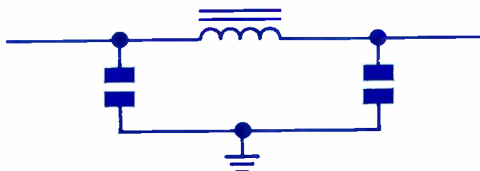

pi filters or L type, inductance input filters as shown here.



The choke resists the unwanted currents, the capacitor shorts any that do get through while DC flows into the load through the choke.

In audio circuitry, the low pass filter uses the choke and the circuit is the same as the inductance input filter just shown. Here again, the low frequency currents are allowed to flow, the higher frequency currents are resisted. The high pass filter, shown here,

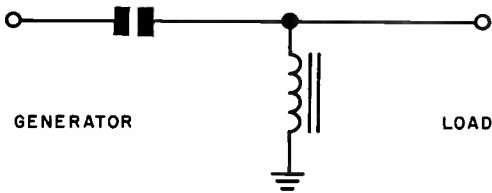

shunts low frequencies via the choke. The choke is also used in bass compensation and cross-over networks. The principle is the same.

A unique device, used in power supply applications, is the swinging choke. This tends to maintain at least its critical inductance over a range of direct current flowing through the choke. This is a point to note. The core of a choke will tend to saturate and effect the inductance if more than the rated current is drawn. The rated inductance is only at the current specified on an ordinary choke. The swinging choke allows a filter to be more effective over a wider range of load current.

This points out a very important fact for anyone wishing to use a choke in a circuit where no DC is present; audio, for instance. The rated inductance is not the true inductance (if a current is specified) so measure the inductance on a bridge if you are calculating a network. If you do not, the capacitor you choose won't be of the proper size - the current is the criterion for the inductance.

The high frequency applications of chokes are many and varied. Here, the choke uses powdered iron, ferrite, or in some cases, no iron at all, and the physical dimensions de-

crease by quite a bit. Since capacity between windings becomes so noticeable as the frequency increases, precautions must be taken when winding the choke to minimize this capacity. The "universal wound" coil is one winding method to reduce capacity and size of coil and can be recognized by its appearance as seen here.

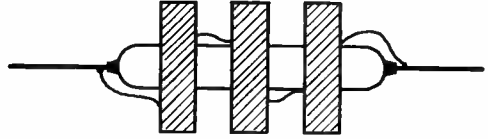

Each winding is a universal wound coil, the total inductance is the sum of the three windings.

Where do you find these chokes in use? One place comes to mind immediately for me. That is as a shunt feed for a transmitter like this:

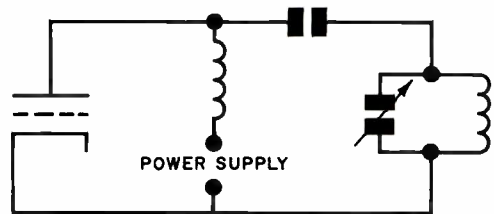

The power supply becomes isolated from rf while DC is not allowed to flow through the tank circuit.

Filament circuits in high frequency i-f amplifiers almost always have rf chokes in series with the filaments to reduce possibility of oscillation.

The rf choke also eliminates feed-through of rf from one system to another via power generators such as in mobile transmitter-receiver installations. Whenever using one where DC is flowing, remember that the choke has DC resistance so make sure the choke is capable of handling the DC present.

I would like to cite one of my experiences with chokes now, to illustrate that they do cause trouble, so keep them in mind when troubleshooting. I was working on a magnetron modulator which was giving all indications that a pulse forming network was bad. The pulse was breaking up and the thyatron, used to generate the pulse, was acting in a manner which indicated an open pulse forming net-

work. A block diagram of the circuit was like this:

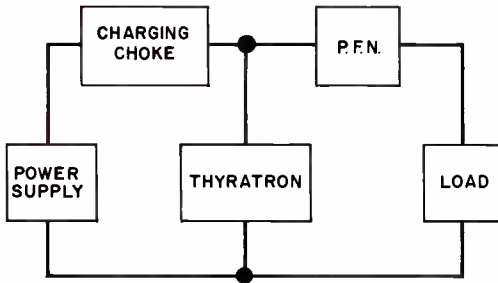

where the pulse forming network charges to the power supply voltage, a trigger fires the thyatron and the energy stored in the pulse-forming network is delivered to the load. The choke is present so that the power supply will not be shorted when the thyatron fires.

After two weeks of troubleshooting which consisted of opening the oil-filled pulse forming network, we turned to the most unlikely suspect, the charging choke. After measuring the DC resistance, we checked the inductance. It was as on the schematic. Grabbing at straws, we replaced it anyway - the pulse was restored to its magnificent beauty and the culprit had been found. The choke was arcing internally and shorting out, causing erratic operation of the thyatron. From now on, the choke is a respected culprit in my troubleshooting book!

THE CIRCUIT OF THE MONTH

The circuit of the month this time may not be needed by you at the particular time, but hold on to it because you never know when a source of interference may move near to you. If you service TV, your customers may have problems from time to time that this circuit can solve - it's a television interference (TVI) filter.

The circuit is a high pass filter, eliminating or attenuating all frequencies below 50 mc, where most of the problems are generated. It is a balanced filter for use with twin lead, designed for 300-ohm line. The rf chokes are hand wound and the specifications are given in the parts list. Do not mount the coils in such a way that transformer coupling can defeat the purpose of the filter. Ninety degree rotation is the best mounting position. The first tapped choke should be tied to earth ground - a water pipe or radiator will work best. The other choke is referenced to the set's chassis.

The filter is based on the action of inductance

and capacitance in relation to frequency. As frequency increases, the X_L increases while X_C decreases. This allows the TV information to pass through the capacitors and not be shunted by the inductance. The lower frequencies are blocked by the capacitors and shunted by the chokes.

If you aren't having problems, but would like to satisfy yourself as to the function of the TVI filter - create some disturbance yourself. Take your rf signal generator and modulate it with 400 cycles, letting it operate on a much lower band, but one whose harmonics will appear in the TV band - say 27 mc. Most signal generators are harmonically rich enough to do the job. Connect a rabbit ear antenna if you can't get close enough to the outdoor antenna - see the sound bars. Now connect our circuit. The bars had better leave the screen! Be sure that the antenna is picking up the interference and that you are not over-powering the front end and driving into the i-f amplifiers - the filter can't help this.

Hope you never have to use the circuit, but if you do see those sound bars, and they're not synchronized with the TV audio - hook up the filter and remember that the choke solves many problems.

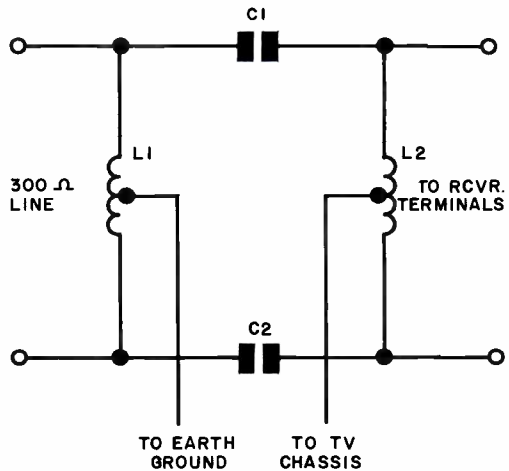

TELEVISION INTERFERENCE FILTER

PARTS LIST

C1,C2 -10 pf capacitors, tubular ceramic

L1,L2 -Choke coils, wound as follows:

8 turns, No. 14 enamel wire, wound on 3/4" diameter, 1" long. Tap both coils at center.

Low Voltage Relay Operation

INCREASED EFFICIENCY WITH SIMPLE CIRCUITRY

BY FLOYD KEITH

The author, sometime back, purchased several surplus relays which were advertised for 12-volt operation. On testing, however, they were found to require 15 volts. The question occurred as to why a relay that worked on 15 volts or more could not be made to work on 12 volts or less? It is general knowledge that it takes a great deal more voltage to pull in a relay armature than is required to hold it in, due to the reluctance of the air gap between the armature and solenoid.

Working on this basis, a check was made on the surplus relays. It was found that 15 volts was required to pull in the relay armature but only 4 volts was needed to keep it in. I concluded that if a relay could be held in at a lower voltage, this would also amount to a savings in power drawn from the battery.

The first circuit worked out by the author to operate relays at reduced voltage is shown in Fig. 1. When the 2-pole, double-throw switch is thrown to the left, which is the normal contact position, the electrolytic capacitor will charge up to the full 12-volt potential of the battery. In order to actuate the relay, the switch is thrown to the right. When this is done, the 12-volt potential of the capacitor is connected in series with the battery, thereby delivering 24 volts to the relay coil. This voltage, of course, is more than enough to actuate the relay. However, in order to avoid reverse polarizing of the capacitor and also to maintain a continuous circuit to the relay

coil, it is necessary to short out the capacitor after it has discharged sufficiently to actuate the relay armature. This function is performed by utilizing 2 relay contacts. These same contacts could also be used to furnish 12-volt power to electrical equipment as indicated.

Although there is nothing critical about this circuit, it is interesting to note that its operation is a function of how much time is required for the relay to pull in, due to its inertia, and also the discharge rate of the capacitor. If the capacitor were to discharge before the contacts closed, then the circuit would not operate.

A reasonable figure for the capacitance value can be arrived at using the following procedure: Assume that we have a relay that takes about .05 second to pull in. The relay requires 15 volts to operate, and the relay coil resistance is 350 ohms. It is desired to operate the relay on 12 volts. This means, then, that when the capacitor is charged and placed in series with our voltage source, we will have 24 volts applied in series with the 350-ohm resistance of the relay coil. The current at this potential would be

$$\frac{24}{350} = .0686 \text{ amp.}$$

Multiplying this figure by the relay operating time we have $.05 \times .0686 = .00343$ (amp seconds).

Substituting this value in the formulas for denoting the charge on a capacitor we have:

$$Q = EC$$

where Q = coulombs or amp seconds

E = voltage applied to capacitor

C = capacity in farads

$$.00343 = 12 C$$

$$C = \frac{.00343}{12} = .00029 \text{ farads}$$

or $C = 290 \text{ mfd.}$

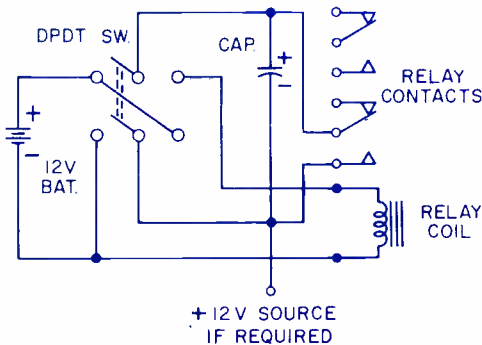

FIG. 1. The first circuit.

Therefore a 300 mfd 15-volt capacitor should prove satisfactory.

Another circuit for reduced voltage operation of relays is shown in Fig. 2. This circuit works quite well if the voltage is not reduced too drastically and also if the relay operating time is not too great. There was no problem in making 24-volt relays operate on 12 volts in this investigation. However, the first circuit discussed proved to be more efficient in operation.

Referring to Fig. 2, when switch SW1 is closed 12 volts is applied across the 12-volt winding of a filament transformer T1. The sudden rise in current produces a high voltage pulse across the 115-volt secondary, which is in series with the 12-volt source to the relay coil.

It is necessary that the polarity on the 115-volt secondary, at the moment of contact, is series-aiding the 12-volt source as shown. In order to avoid a heavy load on the 12-volt source, the primary of T1 is disconnected from the circuit by 2 relay contacts. These same contacts may be used to furnish 12-volt power to electrical equipment. When opening the 12-volt winding, however, a reverse polarity pulse is encountered on the secondary.

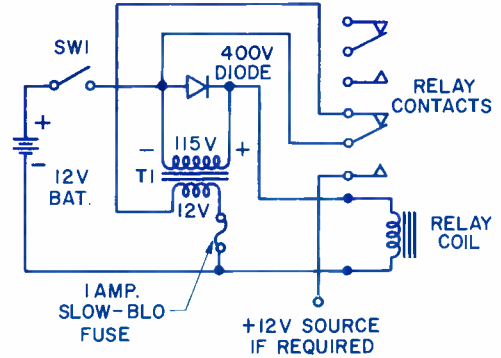

FIG. 2. The second circuit.

This pulse would open the relay if not eliminated. By connecting a silicon diode across the winding as shown, this reverse pulse is effectively eliminated and, in addition, a low resistance path through the diode removes the transformer secondary winding resistance from the circuit.

As a safety factor a 1-amp slow blow fuse should be inserted in series with the 12-volt winding. In the event that this winding is not open-circuited by the relay contacts, then overload protection is afforded to the 12-volt source.

CONAR ORDER BLANK

DIVISION OF NATIONAL RADIO INSTITUTE, 3939 WISCONSIN AVE., WASHINGTON 16, D.C.

PLEASE PRINT

NAME _____

ADDRESS _____

CITY _____ ZONE _____ STATE _____

NRI STUDENT NUMBER

CASH

C.O.D. (20% Deposit required)

EASY PAYMENT PLAN (10% Deposit)

Quantity	Model	Name of Item	Price Each	Total

If you live in Washington, D.C., add 3% sales tax. All prices are net, F.O.B. Washington, D.C.

TOTAL

ON TIME PAYMENT ORDERS please be sure to complete the Easy Payment Plan credit information form on the reverse side of this page and include 10% down payment with your order. ▶

DO YOU KNOW YOUR 'ODES'?

BY ROBERT K. RE

Many electronic terms were coined using the suffix "-ode" from the Greek word, hodos, meaning way or path). How many of the "-odes" listed below can you identify?

1. A - - ode is a two-element device that normally allows current to flow only in one direction. It converts AC to DC, too.
2. The - - - - ode, more commonly called a pentagrid tube, is widely used in converter stages of radios.
3. This device, known as a - - - - ode, exhibits a negative resistance in certain circuits because of secondary emission effects.
4. - - odes are used to gather or collect the electrons in a vacuum tube. They are also one part of a cell.
5. All electronic tubes and transistors have - - - - - odes. In fact, most active electronic devices have them.
6. The - - - ode's many grids serve as electron controllers, accelerators, and collectors. It is used as a converter or oscillator-mixer tube.
7. A - - - - ode tube is known for its high plate resistance and high gain characteristics.
8. This element, electrically, is normally the most negative in a rectifier. The - - - - ode, as it's called, also emits electrons.
9. This electronic device can be either solid-state or vacuum operated--it is called a - - - ode. Most transistors are in this class, as are many tubes.
10. A multi-element tube, the - - - ode is often used in conjunction with another "-ode" in the same envelope for frequency conversion duties.
11. A photomultiplier or electron-multiplier tube has many - - - odes. They act as secondary emitters in the tube.

Answers on page 36.

CONAR EASY PAYMENT PLAN

Note: Easy payment contracts cannot be accepted from persons under 21 years of age. If you are under 21, have this sheet filled in by a person of legal age and regularly employed.

Enclosed is a down payment of \$_____ on the equipment I have listed on the reverse side. Beginning 30 days from the date of shipment I will pay you \$_____ each month until the total payment price is paid. You will retain title of this equipment until this amount is fully paid. If I do not make the payments as agreed, you may declare the entire unpaid balance immediately due and payable, or at your option, repossess the equipment. Your acceptance of this will be effected by your shipment to me of the equipment I have listed.

Date _____ Your written signature _____

CREDIT APPLICATION

Print Full Name _____ Age _____

Home Address _____

City & State _____ How long at this address? _____

Previous Address _____

City & State _____ How long at this address? _____

Present Employer _____ Position _____ Monthly Income _____

Business Address _____ How Long Employed? _____

If in business for self, what business? _____ How Long? _____

Bank Account with _____ Savings Checking

CREDIT REFERENCE (Give 2 Merchants, Firms or Finance Companies with whom you have or have had accounts.)

Credit Acct. with _____ (Name) _____ (Address) _____ Highest Credit _____

Credit Acct. with _____ (Name) _____ (Address) _____ Highest Credit _____

Remote Lamp Monitor

BY RONALD L. IVES

In a wide variety of industrial photoelectric instruments, such as anemometers, turbidity meters, and smoke detectors, an essential component is a small lamp, usually located some distance from the indicator, and commonly neither visible nor easily accessible to the operator. Failure of this remote lamp puts the instrument out of service. Undetected failure of this lamp will result in wasted records, and may lead to a variety of unpleasant technical and legal consequences.

To prevent undetected failure of remote lamps, industrial electronic designers have constructed a variety of telltales, or monitors. Most common is the use of a milliammeter or ammeter in series with the lamp. This works very well provided the operator checks the meter reading regularly. As the operator's duties increase, chances of his not noticing a lamp failure also increase, and use of an "idiot light" in place of a meter becomes desirable. Such an "idiot light", controlled by a relay in series with the remote lamp, is a most effective remote lamp monitor, and many such installations have given excellent service under industrial conditions.

IMPROVED MONITOR CIRCUIT

With the current availability of dependable medium power transistors at reasonable prices, a whole family of improved remote lamp monitors is possible. Representative circuit of such a monitor, with working constants, comprises Fig. 1. Here, the remote lamp, a type 44, is operated from the 12-volt DC supply line through a 27-ohm, 2-watt resistor. In consequence, the lamp burns with slightly less than its rated brilliance, a procedure which extends its life greatly. The lamp-resistor junction is approximately 6 volts positive with respect to ground, so long as the lamp filament is intact.

If the lamp filament opens, the lamp-resistor junction rises to approximately 12 volts positive with respect to ground, assuming no load on the circuit.

This voltage change is used to vary the bias on a transistor, which, in turn, controls a

monitor lamp. Base of the transistor (a type 2N326, NPN) is connected to the lamp-resistor junction. Emitter is held six volts positive with respect to ground by use of a 1N1806 zener diode (6 volts nominal). A No. 44 lamp is connected between transistor collector and supply positive.

When the remote lamp is operating normally, base of the transistor is at approximately the same potential as its emitter, and no appreciable current flows in the collector-emitter circuit. In consequence, the monitor lamp does not light, indicating, to the operator, that all is well with the remote lamp circuit.

When the remote lamp circuit is open (usually indicating a lamp failure), base of the transistor is approximately 12 volts above ground, and 6 volts above the emitter. Under these conditions the transistor conducts strongly, current flows in the collector-emitter circuit, and the monitor lamp lights, indicating, to the operator, that something is amiss with the remote circuit.

Correction of the remote circuit trouble, usually by replacing a burned-out remote lamp, restores the base bias of the transistor to normal (+6 volts), and the monitor lamp goes out.

Although here shown with specific constants,

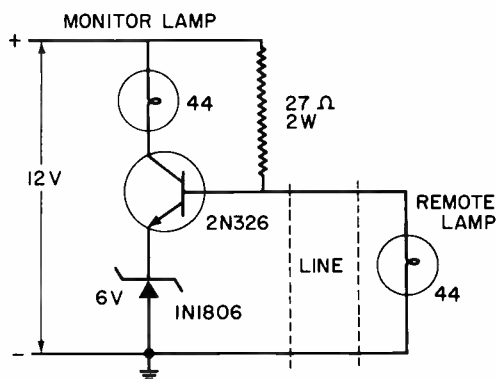

FIG. 1. Circuit of a remote lamp monitor.

this circuit can be adapted for use with a wide variety of lamps and supply voltages by adjustment of the resistor and zener diode voltages. Likewise, by simple application of standard rules, it can be made to work with a wide variety of transistors.

To insure against in-service failures, both the transistor and the zener diode here specified have a much larger current rating than is actually needed. This large margin of safety is incorporated here because added current capacity is relatively inexpensive, whereas "down time" is extremely costly. Likewise, although the transistor normally operates at close to cutoff, and the zener diode normally carries only leakage currents, adequate heat sinks on both (3" square of 1/16" copper) are recommended as extremely cheap insurance.

In-service tests of this remote lamp monitor show that it is superior to the relay type previously used because it has no contacts, and hence is immune to contact trouble. It is also superior to vacuum tube monitors because of much lower cost and because it is apparently immune to "sleeping sickness." A vacuum tube which is operated in cut-off condition for a long period may refuse to conduct when the cutoff bias is removed. A transistor, operated under the same cutoff conditions for several months, will conduct immediately when the cutoff bias is removed.

DIODE IMPROVES I-F SELECTIVITY

The diode detector is almost universally used in AM radio receivers. However, it has one important disadvantage, that of damping the last i-f transformer rather severely. Therefore, one way of improving the i-f selectivity of a vacuum-tube set is to reduce this damping. This can be simply done by using as the last i-f transformer a center-tapped unit such as is made for full-wave detection, and connecting the detector across only half of the winding. This will reduce the damping effect by a factor of four, and should make it negligible in most practical cases. (Transistor sets normally have the detector tapped down on the last i-f transformer in this way.) The only disadvantage of this change is that the audio output from the detector is reduced by a factor of 2. However, most sets have an ample reserve of audio gain to make this up. This loss will be lessened by the increased gain of the i-f amplifier resulting from the reduced damping.

C.E.C.

ON OUR COVER

'Radiation Belt' modeled by Marilyn Finneran of Long Beach, Calif. is a belt-pack unit that may be worn by an astronaut as a communications device to enable scientists on earth to check his heartbeat and other physiological functions. Bendix Corporation engineers who built the system said it will permit scientists to build a "communications stairway" to astronauts during lunar explorations. They demonstrated it at the 17th annual space flight exposition of the American Rocket Society in the Los Angeles Pan Pacific auditorium.

SEMICONDUCTOR REVIEW

(Continued from page 17)

assuming a net negative charge (through the loss of holes). Similarly, the N-type material acquires a positive net charge (due to the loss of free electrons) so that a potential difference exists across the electrically neutral junction area.

In the case of a conventional P-N diode or transistor, an external electrical potential applied to the P-N sections repel electrons and holes toward the junction where they combine, resulting in a flow of current across the junction. The basic action is the same in the photo P-N junction, except that protons of light serve as the source of external energy; imparting enough energy to a valence electron to knock it loose, and now become a free electron which will cross the P-N junction due to the previously mentioned potential present at the junction. The hole created simultaneously with the photo-electron will also be attracted by this field. The passage of the photo-electron and its associated hole across the P-N junction constitutes the "photocurrent," since this photocurrent is proportional to the number of electrons stripped from their respective valence rings by the impinging protons, it is apparent that the photocurrent will be a function of light intensity.

Next month, we'll take a look at some of the other aspects of photocells including spectral response and manufacturing technique for the various semiconductor cells. Additional practical applications and circuits will also be included.

Due to the length problem in this issue, we're saving the "novel circuits" section for next month; at which time you'll see a "double dose." See you next month.

Hole Shooting Simplified

BY
G. F. STILLWELL

Drilling multiple holes accurately can be tricky, and unless carefully done, much time is lost and expensive material is wasted or the neatness of a project is ruined.

The location of the projections--such as dial shafts--for making panel or face plate, can be measured using ruler or divider points but this is sometimes an involved, time-consuming procedure. In addition only a slight error in measuring can result in unsightly over-all inaccuracy. To prevent this, a pattern or template is needed. To make a hole template, "chalk" the ends of projecting shafts, or lugs, and then press a piece of panel-size wood or sheet metal against them. This will transfer the hole or opening location and an accurate panel or face plate can then be made quickly from this template. In many cases where larger openings are to be made in a panel a suitable template can be made quickly with a sheet of aluminum foil of the proper size. Simply press the sheet of foil against the projections or openings and use this for locating the holes to be drilled.

For "one time" use the template can be made from stiff cardboard but for repeated use it should be made of sheet metal or masonite.

When it is necessary to outline or locate openings on a template of a mechanism with interfering projections--such as a record changer--cut the main opening roughly on a sheet of cardboard or plastic and use extension pieces to locate holes accurately along the edges of the mechanism.

In lieu of a pattern or template, a length of

heavy duty wire solder can be used. This material can be shaped readily by hand to form a suitable template or pattern. Accurate hole locations may be made by pressing the wire solder against the projections. This material is ideal for use in making an initial tubing installation. It can be shaped easily around any obstruction and later the tubing, bar or stiff wire can be bent to conform accurately with this pattern. Wire solder can also be used for taking inside measurements and to duplicate the outside outline of any odd-shaped box or opening.

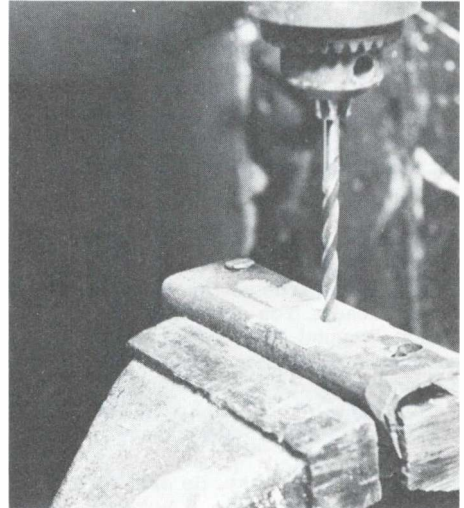

To keep a drill from "traveling," place a piece of masking tape over the area to be drilled as shown here.

For accuracy in starting a drill it is sometimes advisable to use a bit of masking tape pressed against the area where the hole is to be made. Mark the precise hole location with a ballpoint pen and then start the drill using light pressure. The tape will keep the drill bit on center. This is an especially useful idea when a center punch cannot be used in starting a hole.

When drilling holes in plastic or thin material with highly polished surfaces the sheet should be clamped between wooden blocks to prevent tearing out the edges of the hole. In drilling holes in heavy material the work can be simplified by first "shooting" the hole with an undersize drill bit. Follow this with a drill bit of the exact size required.

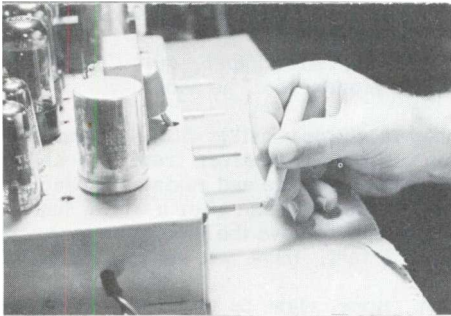

To locate shaft holes for drilling, chalk the ends of the shafts as shown. Hold the mounting panel against them to transfer the markings or make a drilling pattern in this way for accurate hole location.

What Would You Have Done ?

TEST YOUR SERVICING
KNOW-HOW BY MATCHING
WITS WITH LUCKY LYTEL

BY GEORGE D. PHILPOTT

Suburbia U.S.A. remains white and quiet following a night of swirling snowflakes and icy winds. In Lucky's TV shop however, the atmosphere was not so serene, as Lucky cradled the phone with a 'plunk', got up and walked back into the service department. "Mr. Manwellikin, from Flatridge, just called," he said, addressing his shop assistant, Super-Sonic Smith, "and because you didn't have his CB Transceiver repaired yesterday, as you promised him, he claims he nearly froze to death last night! Car got stuck in a drift on a back road, marooned him, and he couldn't call for help."

Super's ears perked, his face flushed, and he retorted defensively, "Well - dig them bananas! Boss, true as I'm standing here, the set was ready. You weren't here. Mr. Manwellikin stopped, had enough anti-freeze in his carburetor to keep ten men from freezin'. He took his rig and tried to install it...dropped it, or somethin' - then brought it back in. Is it my fault he didn't have a radio?"

"No. If that's the story. He didn't tell me all of the facts...have you checked it again?"

Super's gaze shifted towards Lucky's bench space. "I did examine it last night, before closing. It's definitely drawing too much current for a transistorized job - and poppin' fuses. The only work it needed before he took it was a volume control and switch. I thought you might want to check-out the damage this time."

Lucky seated himself at the bench, picked up the transceiver, and carefully inspected the outer case. "No dents. Sure is an attractive package. Very light. Probably doesn't weigh more than five pounds," he mused.

"Eighteen transistors and all of them working. It's the hottest little job you ever saw...when it's working."

Lucky continued his examination - slowly - as though feeling for something more, perhaps right at his finger-tips. Like a small child

touching a new toy for the first time, his fingers slowly twisted the left-side mounting bolt inward. After several complete turns, it would go in no further. Whistling softly to himself, he quickly unthreaded the bolt and peered into the quarter-inch hole. "Uh-oh," he toned, "just as I thought. This is not a factory original bolt. It seems to be about an inch too long. Screws in tight against the printed-circuit board. No wonder we've got trouble, lad."

"Heah - that's a relief!" exclaimed Super. "For a change I don't have to take the rap for something the customer did!"

Lucky grinned: "Come on now, Super," he said, "I'm not quite that hard on you. Am I?"

"It's not you so much, Boss...but some of these CB'rs...well some of 'em want YOU to know that THEY know all the answers, six weeks after they get their license. You'd be surprised how much they learn about transceivers in a few short weeks. I've had 'em tell me all about standing-wave ratios...and the reflected inductance of a ground-plane discriminator. Another guy last week went into details on how I should repair his rig - said his 'rocks' were XYL-cut and polished to multi-vibrate on the Z axis. According to him, a really active crystal should always amplify on the sixth harmonicer."

At this outburst, Lucky began to laugh. He gave his protegee a good-natured pat on the back, said, "I'll have to admit you have your troubles, Son. Maybe you deserve a raise."

"I sure do," fired Super, quite happy now. "...real money, too!" he added.

Lucky let the crack slide without comment and removed the transceiver from its case and began some voltage and resistance checks. "I may be nuts," he said after a while, "but this thing seems to have the same voltages everywhere I test. Have we got a schematic?"

"Sure, Boss, right on the bench in front of you," said Super, pointing.

Lucky unfolded the pages and began a thorough search of the power-supply section. Apparently not finding what he wanted, he grasped the mike and pressed the transmit button.

The rf indicator lighted. "It's okay on transmit, but dead on receive," he commented.

"How about the mounting bolt?" asked Super.

"It shorted something - but what?" Lucky breathed. And then a big smile came to his face. "I believe I've found it," he said, dropping the test leads and reaching for the sidecutters. He clipped a diode lead and again tried the ohmmeter. "Yep! Look at this, Super," he said.

The young technician moved over and examined the transceiver briefly. "Shorted diode, huh? Those little babies can do it."

Again Lucky returned to the diagram and checked the circuit. Turning the page, he located the component description and gave a low whistle. "It's a diode alright - a ZENER diode voltage regulator. And, if I remember correctly, they are very critical, so far as operating voltage is concerned."

"Critical ain't the word for it!" exclaimed Super, all eyes for the job, now. "A few weeks ago I had some kind of a set in here with an open zener regulator - you remember...an R.I.T., or something like that. I tried a substitute resistor, because the zener acted as the lower leg of a voltage-divider network and we wanted to see what would happen. The receiver acted fine on Crystal-Receive, but when we switched to Variable-tune it motorboated, on-station, and the squelch went crazy. Remember?"

"How could I forget?" Lucky groaned. "That was the job where one-tenth of a volt difference in the circuit affected the oscillator alignment. We tried every parts distributor in town and couldn't find an 8.6 volt unit."

"Yeah," said Super, "I finally put in a 9.1 volt, 1-watt silicon. We re-tuned the receiver section and let the squelch go until we could get the right part from the factory."

"It looks like this is a repeat performance, Super. This tiny glass bead is rated at 8.6 volts, too...400 milliwatts."

A faint smile tinted the corners of Super's mouth as he started to say something and then stopped. "I found out one thing, Boss," he finally said. "It sure pays for a serviceman to keep-up on the latest advances in our trade. Zeners are just one of the solid-state devices starting to show here lately. They're wonderful components too, considering the jobs they handle. I've been studying them, you know."

Lucky gave a little, embarrassed type of snort

at this one, but he still held an Ace. "Well, I'm certainly happy to learn these things, Super. In fact, just to show you how enthralled I am with your knowledge of zeners, if you can figure a way to fix this set without ordering the part from the factory, or substituting like we did before - and there is a way - I'll give you a ten dollar raise. How does this sound?"

"Sound! It sounds like I'm clear on all channels!" he replied. "I'll have Mr. Manwelliken's juke-box cookin' in ten-minutes, flat."

"I don't want it to cook too hard, Mr. Smithy," the Boss stated. "I have not forgotten the heat-waves radiating into the rafters from several other jobs on your list, here lately."

"Boss - I'm serious! I could get tricky and install two zeners, a ten-volt unit, followed by a 100-ohm pot, into a 5.2 volt job. Take the center-tap off the control and adjust the regulated voltage to 8.6. But this way costs money.

The method I use is efficient and thrifty...in fact, many shops around the country will eventually discover my secret."

Again Lucky smiled grimly. "Dig right in, son. For a change, it's your show."

Super got up without another word and stepped to the transistor parts-cabinet.

Under these circumstances, WHAT WOULD YOU HAVE DONE to have been able to repair the transceiver?

ANSWER ON PAGE 30



"Sounds like you're grounded somewhere."

Decibels

and

Sound

THIS IS THE FIRST IN A SERIES

OF ARTICLES ON SOUND SYSTEMS

In sound work, every component causes a gain or a loss to the overall system. A power amplifier produces a power gain, a voltage amplifier produces a voltage gain, and distribution lines and impedance matching transformers or devices cause losses. Speakers consume power to produce sound and, therefore, they are technically losses in a circuit.

One method of making the necessary system calculations is to use the percentage loss (ranging from 0 to 100%) and the percentage gain (ranging from 0 to 100,000% or higher), multiply the signal by the appropriate percentage for each component in the circuit on a step by step basis, with additions for each gain and subtractions for each loss for all the components, thereby determining the conditions at any point in the system.

To illustrate, an original signal of 10 milliwatts through a line with 15% loss to a power amplifier with 100,000% gain would result in a power level of 10 milliwatts minus the line loss (10 times 15%) or 8.5 milliwatts plus the power gain (8.5 times 100,000%) or 8500 milliwatts (8.5 watts).

If the losses are treated as gains of less than one, e.g., a 15% loss results in 85% of the original signal, then the overall percentage can be multiplied together. In the illustration,

85% times 100,000% represents an overall gain of 85,000% and the original 10 milliwatts is changed by 85,000% to 8500 milliwatts or 8.5 watts. This method rapidly becomes cumbersome in a sound system of multiple components.

The decibel system is logarithmic in character, and system calculations can easily be made by adding decibels for a power gain and subtracting decibels for a power loss. The general formula for determining the number of decibels gain or loss in a circuit is

$$\text{db} = 10 \log_{10} \frac{P_2}{P_1}$$

where P_2 is the larger power and P_1 is the smaller power. If the output power is larger than the input power, a power gain is represented and the decibels are added. If the output power is less than the input power, a power loss is determined and the decibels are subtracted.

If the input and output voltages and currents operate at equal impedances, and since power is equal to voltage squared divided by impedance, or current squared times impedance, circuit gains or losses may be expressed in terms of audio voltages or audio currents as follows:

$$\text{db} = 20 \log_{10} \frac{V_2}{V_1}$$

or

$$\text{db} = 20 \log_{10} \frac{I_2}{I_1}$$

where V_2 and I_2 are the larger voltage and current respectively, and V_1 and I_1 are the

smaller voltage and current respectively. Again, a gain is added and a loss is subtracted. Mathematical tables or an appropriate slide rule can be used for these calculations.

There are several important ratios which can be memorized easily and for practical purposes, tables and slide rules are not required. Decibels can be added or subtracted to any point in a system, and then converted to actual power, voltage, or current by simple multiplication or division.

A gain or addition of one decibel multiplies power by 1.25; a loss or subtraction of one decibel divides power by 1.25; a gain of two decibels multiplies power by 1.6, a loss of two decibels divides power by 1.6, a gain of three decibels multiplies power by 2, a loss of three decibels divides power by 2; a gain of ten decibels multiplies power by 10, a loss of ten decibels divides power by 10.

To illustrate, a power level of .001 watt (one milliwatt) subjected to a power gain of 45 db (10 db plus 10 db plus 10 db plus 10 db plus 3 db plus 2 db) would result in one milliwatt times 10 times 10 times 10 times 10 times 2 times 1.6 or 32,000 milliwatts or 32 watts of output power. Using more accurate logarithmic tables would result in a calculation of 31.6 watts, but, for practical purposes, the added accuracy is not significant.

One milliwatt is commonly used as a reference in audio work. The decibel can be modified to show absolute power rather than relative power to a "decibel referred to one milliwatt" and expressed as "dbm." 0 dbm represents one milliwatt of power and the so-called "zero level line" and the "0" reference on VU meters. Now 10 dbm (an addition of 10 db to 0 dbm) becomes 10 milliwatts, 20 dbm becomes 100 milliwatts, 30 dbm becomes 1000 milliwatts or one watt, 40 dbm is 10 watts, 50 dbm is 100 watts, and 60 dbm is 1000 watts.

When working with voltage or current, the addition of 20 db is required for a multiplier of 10, and the subtraction of 20 db means division by 10. Six db involves a factor of 2, four db means a factor of 1.6, two db a factor of 1.25, and one db a factor of 1.1.

Again to illustrate, a signal of .001 volt (one millivolt) amplified by a unit with 53 db voltage gain (20 db plus 20 db plus 6 plus 6 db plus 1 db) would be raised to a level of one millivolt times 10 times 10 times 2 times 2 times 1.1 or 440 millivolts (.44 volts).

The table shown in Fig. 1 summarizes these practical values.

An understanding of the nature of sound will aid in the selection of the proper audio equipment. The range of power for the human voice is from several microwatts (about -25 dbm) for a female voice to several thousand microwatts (about 5 dbm) for a husky male voice. Maximum voice power occurs in the range of 300 to 600 cycles per second; peaks may be present at all frequencies and they may be as high as 10 db above the average voice power.

Human voice energy is distributed over a range of 80 to 12,000 cycles per second, with the range from 8,000 to 12,000 CPS being important only in Oriental languages. Intelligibility, including the recognition of words and ordinary sounds requires a band of frequencies from about 300 to 3500 CPS, if the production of these frequencies is relatively distortion free. If recognition of speakers of "naturalness" is required, frequencies from 150 to 5000 CPS should be included in the system.

Since electronic tubes and many of the components associated with them do not amplify or handle signals in a linear manner, i.e., the output signal is not an exact replica of the input signal, some change or distortion of the original signal may occur during amplification. Harmonics of the frequencies being amplified may be introduced into the system, or frequencies may interact (intermodulate) to produce new or additional frequencies at the output. Harmonic and intermodulation distortion are usually expressed in percent of the total output signal, and may be specified separately or grouped under a total distortion term. In voice work, the total distortion of 5% or less may be neglected, and a total distortion of up to 15% may be tolerated in some cases.

Our musical instruments produce harmonic rich sounds in the range from 20 to 20,000 CPS. Modern "hi-fi" enthusiasts do their best to reproduce all of these sounds with very low distortion, and in special commercial applications such as theaters and auditoriums designed for concerts and music recitals, the cost of wide range and minimum distortion

DECIBELS OF POWER	DECIBELS VOLTAGE OR CURRENT	FACTOR MULTIPLICATION OR DIVISION
0.5	1.0	1.1
1.0	2.0	1.25
2.0	4.0	1.6
3.0	6.0	2.0
10.0	20.0	10.0

FIG. 1. Decibels and factors for system analysis.

equipment may be justified. In ordinary commercial sound systems, it is neither desirable nor economically practical to produce music over the entire range or with total distortion of less than 3%.

A good background system for quiet areas needs to reproduce a range of from 100 to 8000 CPS, with 5% or less distortion from 100 to 200 CPS and 3% or less distortion from 200 to 8000 CPS for agreeable-pleasant sounding music. In noisy areas, a response from 150 to 5500 CPS is entirely adequate.

The energy in the music from a full orchestra is about equally divided above and below 1000 CPS with peak power between 300 and 600 CPS, which coincides with the range of voice peak power. There is considerable variation among musical instruments in the amount of energy in the fundamental notes and in the harmonics. The notes from an oboe, for example, have about 2/3 of the total sound energy in the fourth and fifth harmonics, while the notes from a marimba or xylophone have almost all the energy in the fundamental frequencies. The dynamic range of a live orchestra can be as high as 40 db, while the dynamic range of an ordinary phonograph record is rarely more than 20 db.

There are several physical laws applying to sound which affect our selection of sound system components.

The speed of sound in dry air at 0° F is 1050 ft./sec., at 70° is 1130 ft./sec., and at 100° F is 1160 ft./sec. The speed of sound is important in large sound systems in determining echoes, reflections, and time of arrival of sound from two different sources. The difference in the speed of sound at different temperatures also gives us an outside phenomenon which affects our sound systems. A positive temperature gradient of the air (temperature increasing as we increase the height above ground) results in bending the sound waves toward the earth. This bending of sound waves can be noted by observing the ease with which sound travels over water on a warm day, when the air is coolest at the surface of the water. Unfortunately, the negative temperature gradient is more often encountered on hot days when the ground is warm and the air becomes cooler as the height above ground is increased. Sound waves then bend away from the surface of the earth, and our sound distribution problems are increased.

Sound is attenuated in air according to the inverse square law and is reduced 6 db for each distance doubled. If the intensity of sound is known at a certain point in front of a loudspeaker (specified by the manufacturer in

terms of watts input) the sound level at a given point away from the speaker can be calculated. On outside systems, where reflections can be neglected, calculation is simple, but on inside systems reflected energy is an important part of the sound energy at the listener. In large auditoriums, at distances above 50 feet from a loudspeaker, most of the sound energy reaching the listener is reflected. In an auditorium with a reverberation time (time between generation of sound and the time the sound is 60 db below the original level) of one or two seconds, because of reflected energy, the sound level at points 20 feet or farther from a sound source can be from 10 to 15 db higher than we would expect from the inverse square law relationship.

In dry air, sound is attenuated as the square of the frequency. In ordinary outside air attenuation at high frequencies is worse than in dry air, a definite problem over long projection paths. Inside, this factor of more attenuation at higher frequencies is somewhat overcome by the tendency of reflected energy to be higher at higher frequencies.

This background in sound characteristics and levels should be an aid in understanding the selection of the equipment recommended for various applications in the next article of this series.

DO YOU KNOW YOUR 'ODES'?

(Page 28) Answers

- | | |
|--------------|------------|
| 1. DIode | 6. OCTode |
| 2. HEPTode | 7. PENTode |
| 3. TETRode | 8. CATHode |
| 4. ANode | 9. TRIdode |
| 5. ELECTRode | 10. HEXode |
| 11. DYNode | |

ANSWER TO LUCKY'S PROBLEM

What Would You Have Done? - page 32

At the parts cabinet, Super-Sonic Smith opened the drawer and finally located an exact replacement, 8.6 volt unit. He removed it from the package and held the tiny object extended, for Lucky's surprised examination. Because Super had been given the task of ordering one replacement from the factory, at a previous date, he had at this time correctly surmised that ordering an extra unit would be wise. Considering the net cost of an extra unit against the problem of obtaining local replacement, the possibility of heat-damaging a replacement, breakage, or just plain losing it somewhere on the floor, made his decision worthwhile - and he received his ten dollar raise.

New Products



"Big in everything but size!" That's the opinion of everyone who has had a glimpse of the fabulous new Freeman "660 Senior" portable tape recorder.

The "660 Senior" is a compact 7-1/2 x 9 x 3 inches weighs just 8-1/2 pounds, yet it combines -- for the first time in a portable tape recorder -- such "big" tape recorder features as a digital index counter; a cue (pause-edit) lever that's precise enough to split a short word; super fast forward and rewind; a self-contained AC power supply and a self-contained battery cartridge; and a speed switch on top of the deck panel.

Six-channel RAY-TEL TWR-4 citizens band radio by Raytheon Company has built-in S-meter to monitor transmitter and receiver performance and is pre-wired with an external socket to accommodate a selective calling unit. Trim tabs provide precision frequency control.

New addition to Raytheon CB line is offered at suggested list price of \$179.95.



Shure Brothers has introduced a radically new Stereo Dynetic cartridge with a no-scratch, retractile stylus that tracks at an effective vertical angle of 15°.

Called the M44, the new cartridge represents a notable advancement in cartridge design, because its 15° stylus is especially set to track records at the same effective vertical stylus angle major recording companies are now using when they cut records. The 15° angle has also been proposed as the standard of the Record Industry Association of America and the Electronic Industries Assn.

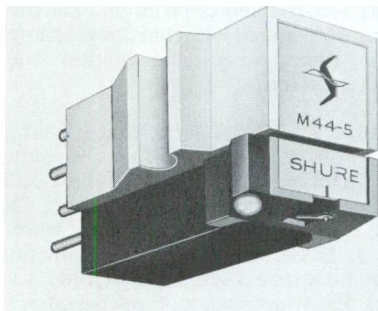

Six new Uni-Veratile*top-hat silicon rectifiers (foreground) introduced by Texas Instruments directly replace 43 popular general-purpose types. The new TI devices, the result of recent diffusion process advances, combine the best electrical characteristics and the lowest prices of the older units. Rectifiers which can be replaced by the new 1N4364-1N4369 series are 1N530-1N535, 1N537-1N540, 1N547, 1N600-1N606, 1N600A-1N606A, 1N1095-1N1096, 1N1100-1N1105, 1N1487-1N1492, and 1N1692-1N1697.

*Trademark

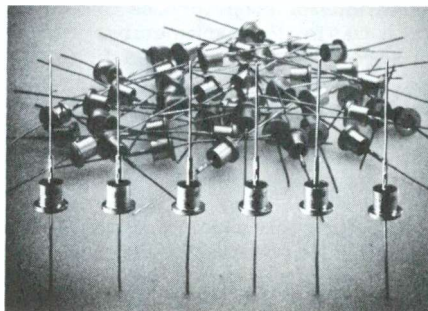

ALUMNI NEWS



J. Arthur Ragsdale.....	President
Howard Tate.....	Vice President
Frank Zimmer.....	Vice President
Eugene DeCaussin.....	Vice President
Jules Cohen.....	Vice President
Theodore E. Rose.....	Executive Sect.

CHAPTER CHATTER

CHICAGO CHAPTER now has a 5-tube AC-DC broadcast superheterodyne demonstrator for the use of its members. All NRI men, students or graduates, are cordially invited to come to the meetings and take advantage of the opportunity to use the chapter's equipment. See "Directory Of Local Chapters" for place and time of meetings.

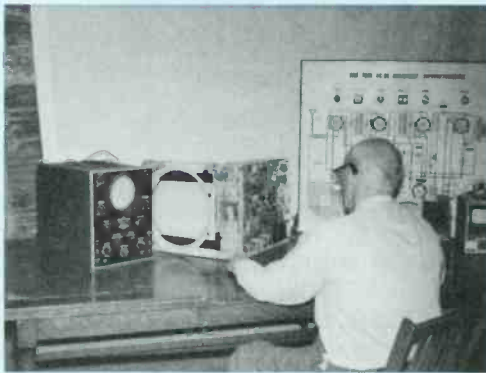

Charles Mead, Secretary of the Chicago Chapter, using the chapter's five-tube AC-DC broadcast superheterodyne demonstrator.

DETROIT CHAPTER'S Jim Kelley conducted a program in which he went into a thorough discussion of oscilloscope probes. The members were interested to learn about the various applications of scope probes in service work and it was felt that each member present learned a great deal from Jim's fine presentation. Charles Cope brought his father, Mr. Charles Cope, Sr., of Topeka, Kansas, to this meeting. The members were happy to have him as a visitor and did their best to add interest to his visit to Detroit.

Two days before this meeting, many of the members attended a demonstration on service instruments sponsored by the B and K Manufacturing Co. and the Glendale Electronic Supply Co. Those attending learned a great

deal and enjoyed the refreshments served at the end of the program.

Newest member to join the Chapter is Mr. Roy Miller. Welcome to the Chapter, Roy.

FLINT (SAGINAW VALLEY) CHAPTER put on an exceptionally good program which the members call a Service Forum. James Windom contributed a color TV set for the evening. All members present participated in the program, each submitting his ideas resulting from his own knowledge and service experience. Various instruments including the scope were used to localize the trouble.

Donald Darbee of Caro (60 miles from Flint) brought in a real dog -- a black and white TV set which had pie crusting. The trouble was eventually located and cleared up. The members were so pleased with this Service Forum that they planned to feature another one at their next meeting.

HACKENSACK CHAPTER'S feature at one meeting was a series of four taped illustrated lectures furnished by Howard Sams Co. The lectures covered four phases of color Television: 1. The Fundamentals of the Color TV System; 2. Receiver Circuit Fundamentals; 3. Color Receiver Circuit Analysis; 4. Installation and Maintenance. Each member was furnished a "COLOR TELEVISION REVIEW", a comprehensive set of notes, fully illustrated, supplementing the lecture series. There was a hearty vote of thanks to Howard Sams for a very interesting meeting.

The meeting was further improved by the admission of Joel McClyde, Sr., as a member. Our congratulations, Joel!

LOS ANGELES CHAPTER members were impressed by a talk given by Mr. Charles Reefa, an immigrant from Cuba and a graduate of the Henphill School of Electronics. He came to the U. S. two years ago. He knew no English then but mastered it to the extent that he was able

to complete his course with Hemphill. He is enthusiastic about the United States and is grateful to be here.

An important feature of the meetings is the use of a slide projector during group discussion programs. Experience has proved the value of the projector.

MINNEAPOLIS-ST. PAUL (TWIN-CITY) CHAPTER considered it advisable to devote most of a meeting to talking over the handling of problem customers. After lengthy discussion, it seemed that the unanimous conclusion was that there will always be problem customers but that it is nevertheless a good idea to review the situation from time to time. The members were then treated to a delicious repast furnished by Mrs. John Berka. There was an abundance of ham sandwiches, homemade dill pickles, date bars and cookies, etc., to which the members did full justice.

NEW YORK CITY CHAPTER, like all the other local chapters, extended a warm welcome to Executive Secretary Ted Rose on the occasion of his annual visit together with Mr. J. B. Straughn of the NRI Staff. The members were especially gratified to be told that Frank Zimmer had again been elected as a National Vice-President. Ted Rose then conducted a brief ceremony in which he gave emphasis to Frank Zimmer's many years of faithful service to the Chapter and administered the oath of office to him.

Mr. Straughn then gave a masterfully conducted Cook's Tour of the internal workings of a transistorized radio as well as the Conar AC-DC Radio Receiver. In pointing out various power supply troubles he showed that mistakes could be made on schematics and that one should not "short circuit" his own knowledge and experience when doing service work. Chairman Dave Spitzer followed Mr. Straughn with another of his spirited, amusing, and helpful talks on bench-servicing techniques, especially as applied to the appliance and oil burner field, and Jim Eaddy discussed the diode aspects of transistors.

The chapter welcomed back a returning member, Jerry Nimrod, and new member John Ferruggia. Our congratulations, gentlemen!

PHILADELPHIA-CAMDEN CHAPTER made its long-anticipated tour of the Westinghouse plant at Metuchen, N. J., -- and it was a corker. Bill Heath, Westinghouse representative and an honorary member of the Chapter, made the trip with the group. On arrival at the factory some of the supervisors addressed the group, explained what Westinghouse is doing, introduced the group to various department heads and to the tour guides. The members

saw how a Television and a Radio Receiver are made from scratch. Among the most impressive things was to see how the printed circuit boards are made. There were tremendous belt lines at which girls work and each girl has a few parts to put in the set. The members saw the whole operation and several were heard to remark that "even the soldering of the circuit board is something to see." After a delicious lunch during which the group talked to various bosses, the tour was continued to the testing part of the plant and saw how the packaged product went through rigid tests of dropping, banging, shaking, and other various means of torture. The members also saw a number of TV sets in operation for various type tests. It was by far the most interesting tour that the Chapter has yet made.

The time and place for the Chapter's 30th Anniversary Celebration has now been fixed. It will be held at the Southwark A. C. Club on May 16, 1964.

Last year's slate of officers have been re-elected to serve for 1964 with one exception: Former Vice Chairman Fred Seganti was replaced by Harvey Morris. The other officers are: John Pirrung, Chairman; Joe Burke, Financial Secretary; Jules Cohen, Recording Secretary; Charles Fehn, Treasurer; George Dolnick, Librarian; and Joe Giba, Sergeant-At-Arms. Our congratulations to these successful candidates.

PITTSBURGH CHAPTER reports its slate of officers to serve during 1964 as follows: James L. Wheeler, Chairman; J. M. Burnelis and A. J. Ciarrocca, Vice Chairman; Edgar Lowther, Recording Secretary; Howard Tate, Corresponding Secretary; William Sames, Treasurer; David Benes, William Lundy and Gilbert Harding, Board of Directors. Our congratulations to these officers!



Some of the officers of the Pittsburgh Chapter for 1964. L to r, seated: Ed Lowther, Jim Wheeler, J. M. Burnelis. Standing: Howard Tate, Bill Lundy, Dave Benes.

Past National President of the NRI Alumni Association and former chairman of the Chapter, Frank Skolnik, administered the oath of office to the new officers. The members then partook of a buffet supper and the members enjoyed the social get-together.

SAN ANTONIO (ALAMO) CHAPTER has also informed National Headquarters of its officers to serve for the current year. They are Sam O. Dentler, Chairman; Jesse DeLao, Vice-Chairman; John C. Chaney, Jr., Treasurer; and Sam T. Stinebaugh, Secretary. Our best wishes to these officers.

There was no meeting in December because of the Christmas Season. A film on some phase of Electronics was scheduled to be shown at the next meeting.

SAN FRANCISCO CHAPTER arranged some time ago for a visit to the United Airlines,

as reported in the last issue of the NRI Journal. United Airlines followed through on its promise; chapter members were welcomed to United's maintenance shop and communications department. Art Ragsdale, National President of the NRI Alumni Association this year, gave a detailed report on the trip, which was found fascinating by all the members who took advantage of the opportunity to make the trip.

Directory of Local Chapters

Local chapters of the NRI Alumni Association cordially welcome visits from all NRI students and graduates as guests or prospective members. For more information contact the Chairman of the chapter you would like to visit or consider joining.

CHICAGO CHAPTER meets 8:00 P. M., 2nd and 4th Wednesday of each month, 666 Lake Shore Dr., West Entrance, 33rd Floor, Chicago. Chairman: Frank Dominski, 2646 W. Potomac, Chicago, Ill.

DETROIT CHAPTER meets 8:00 P. M., 2nd and 4th Friday of each month. St. Andrews Hall, 431 E. Congress St., Detroit. Chairman: James Kelley, 1140 Livernois, Detroit, Mich., VI-1-4972.

FLINT (SAGINAW VALLEY) CHAPTER meets 8:00 P. M., 2nd Wednesday of each month at Chairman Andrew Jobbagy's Shop G-5507 S. Saginaw Rd., Flint Mich. OW 46773.

HACKENSACK CHAPTER meets 8:00 P. M., last Friday of each month, Hackensack YMCA, 360 Main St., Hackensack, N. J. Chairman: George Schalk, 471 Saddle River Rd., Ridgewood, N. J.

HAGERSTOWN (CUMBERLAND VALLEY) CHAPTER meets 7:30 P. M., 2nd Thursday of each month at the YMCA in Hagerstown, Md. Chairman: Francis Lyons, 2239 Beverly Dr., Hagerstown, Md. Reg 9-8280.

LOS ANGELES CHAPTER meets 8:00 P. M., 2nd and last Saturday of each month, 4912 Fountain Ave., L.A. Chairman: Eugene DeCaussin, 5870 Franklin Ave., Apt. 203, Hollywood, Calif., HO 5-2356.

MINNEAPOLIS-ST. PAUL (TWIN CITIES) CHAPTER meets 8:00 P. M., 2nd Thursday of each month, Walt Berbee's Radio-TV Shop 915 St. Clair St., St. Paul. Chairman: Paul Donatell, 1645 Sherwood Ave., St. Paul, Minn., PR 4-6495.

NEW ORLEANS CHAPTER meets 8:00 P. M., 2nd Tuesday of each month at Galjour's TV, 809 N. Broad St., New Orleans, La. Chairman: Herman Blackford, 5301 Tchoupitoulas St., New Orleans, La.

NEW YORK CITY CHAPTER meets 8:30 P. M., 1st and 3rd Thursday of each month, St. Marks Community Center, 12 St. Marks Pl., New York City. Chairman: David Spitzer, 2052 81st St., Brooklyn, N. Y., CL 6-6564.

PHILADELPHIA-CAMDEN CHAPTER meets 8:00 P. M., 2nd and 4th Monday of each month, K of C Hall, Tulip and Tyson Sts., Philadelphia. Chairman: John Pirrung, 2923 Longshore Ave., Philadelphia, Pa.

PITTSBURGH CHAPTER meets 8:00 P. M., 1st Thursday of each month, 436 Forbes Ave., Pittsburgh. Chairman: James L. Wheeler, 1436 Riverview Dr., Verona, Pa. 793-1298.

SAN ANTONIO ALAMO CHAPTER meets 7:30 P. M., 3rd Wednesday of each month, Beethoven Hall, 422 Pereida, San Antonio, Chairman: Sam O. Dentler, 329 Southcross, San Antonio, Texas. WA 2-8682.

SAN FRANCISCO CHAPTER meets 8:00 P. M., 1st Wednesday of each month, 147 Albion St., San Francisco. Chairman: Peter Salvotti, 2543 Great Hwy., San Francisco, Calif.

SOUTHEASTERN MASSACHUSETTS CHAPTER meets 8:00 P. M., last Wednesday of each month, home of John Alves, 57 Allen Blvd., Swansea, Mass. Chairman: James Donnelly, 30 Lyon St., Fall River, Mass. OS 2-5371.

SPRINGFIELD (MASS.) CHAPTER meets 7:00 P. M., last Saturday of each month at shop of Norman Charest, 74 Redfern St., Springfield, Mass. Chairman Steven Chomyn, Powder Mill Rd., Southwick, Mass.

Now in stock for
IMMEDIATE
DELIVERY

CONAR

INSTRUMENTS AND PARTS

Test it quickly and accurately with

CONAR Model 221 CATHODE CONDUCTANCE TUBE TESTER

Tests all series string and up-to-date tubes, as well as 4, 5, 6, 7-pin large, octal, loctal, 7, 9, 10-pin miniatures, 5, 7-pin nuvistors, novars, compactrons, multi-section tubes, gas rectifiers, and remote control gaseous types. Checks 17 individual filament voltages from 75 to 110 volts. Independent filament terminal selection locates all terminals regardless of pin position. 12-lever element selector system simplifies cathode leakage and inter-element short tests, guards against obsolescence. Roll chart lists over 2,000 U.S. and foreign tubes — updated frequently. Other special features.

Kit (221UK) **\$39.50** Assembled (221WT) \$57.50
\$5.75 down, \$5.00/mo.
\$3.95 down, \$5.00/mo. (shipped Exp. Coll.)



CONAR

REPLACEMENT PARTS KITS
CAREFULLY SELECTED ASSORTMENTS



RADIO-TV PARTS ASSORTMENT

Most-needed replacement parts: volume controls, switches, control shafts, selenium rectifiers, resistors, capacitors, electrolytics, pilot lamps, univ. oscillator coils, 456 kc i.f.s., dial repair kit, line cords, univ. AC-DC output trans., 12BA6, 12BE6, (3) 35W4, (1) 12AT6, (1) 50C5 in steel tool box.

\$60.00 value for: **\$29.95**
(24UK Exp. Coll.)
\$3.00 down, \$5.00/mo.

Economy assortment—without tubes, rectifiers, volume control: **\$19.95**. \$2.00 down, \$5.00/mo. (25UK Exp. Coll.)

172-RESISTOR ASSORTMENT

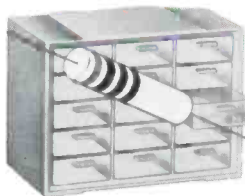

Top-quality, most needed resistors for hobbyist, technician, engineer, experimenter. Packed in 15-drawer styrene knickknack cabinet. All are 10%, 1/2 watt rated or better. 30 values, from 47 ohm to 10 meg.

\$38.35 value for: **\$15.70**
shipped parcel post (28UK)

120-CAPACITOR ASSORTMENT



Top-grade, most needed capacitors: ceramic, disc, and paper. All are rated at 400V or 600V. Shipped in sturdy 15-drawer styrene knickknack cabinet for your convenience.

\$41.15 value for: **\$20.70**
shipped parcel post (29UK)

USE HANDY ORDER FORM ON PAGE 27—CASH OR TERMS

Close-Out SALE

CABINET FOR MODEL W

VTVM (pictured)

If you haven't put your Model W VTVM in a cabinet yet—now is the time. Available through CONAR—this attractive, durable cabinet will protect and professionalize your VTVM. Installation takes one minute—and a screwdriver! Designed specially for your VTVM to make you proud of performance and appearance. Also serves as a handy cabinet for experimental chassis. Includes chrome handle and screws. Stock # ICY. This cabinet is designed only for the Model W VTVM (pictured). Be sure to check Model number of your VTVM before ordering.

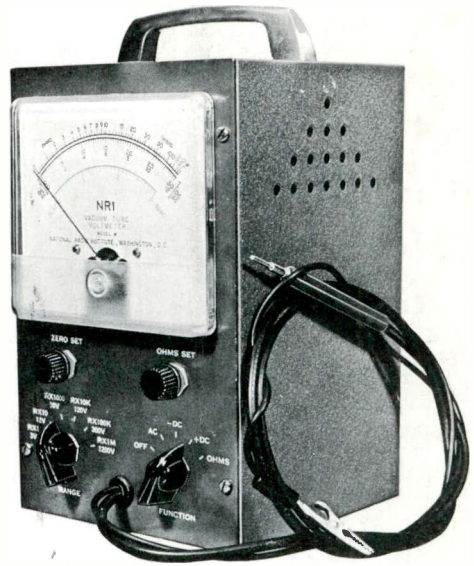

Reg. Price \$3.75 (plus postage) Use order blank on page 27.

Sale Price \$2.25 (postage included)

Mr Ed H Engel
906 Taylor
Crystal City Mo

H19-C239

NRI JOURNAL
3939 Wisconsin Ave.
Washington D. C. 20016

Second-class
postage paid
at Washington, D. C.