



# journal

DECEMBER 1963

35 Cents

In this issue:

**AUTO RADIO  
SERVICING  
TECHNIQUES**

**AUDIO CABLING**

**TIME-LIMITED  
SWITCHES**

**AUTOMATION BY  
PUNCHED TAPE**



Now in stock for  
**IMMEDIATE  
DELIVERY**

"VALUE-RATED" **B&K** INSTRUMENTS FROM

# CONAR

*Now everyone can set up and service COLOR TV!*

New **B&K** Model 850

## COLOR GENERATOR



Today's most complete, versatile color unit! Set up, analyze, service Color TV with amazing ease. Exclusive window-viewer Pattern Display Standard; selector produces patterns, burst, colors individually; ultimate line and dot stability; precise demodulator alignment; automatic deconvergence; exclusive color gun killer; exclusive sweep jack for 15,750 cycle signal; crystal-controlled 4.5 mc. sound signal and many other outstanding features. A real "right arm" for Color TV work!

CONAR PRICE: **\$195<sup>95</sup>** \$19.60 down,  
\$17.00/mo.

New! Compact Model 1074

## **B&K** TELEVISION ANALYST



Point-to-point signal injection technique simplifies, speeds TV troubleshooting. Isolates, pin-points any problem in video, audio, r.f., i.f., sync and sweep sections of black & white and color sets. An ideal instrument at an ideal price. A true profit-maker!

CONAR PRICE: **\$244<sup>95</sup>** \$24.50 down,  
\$22.00/mo.

## **B&K** CRT 445 Picture Tube TESTER-REJUVENATOR

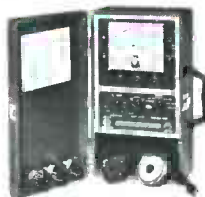

Quickly checks, corrects all b&w and color picture tubes right in the home—in the set. Checks each color gun, plus leakage, shorts, opens, emission, gas content and predicts useful life. 4½" plastic meter, neon bulb indicators for quick, easy readings. Handsome case.

CONAR PRICE: **\$74<sup>95</sup>** \$7.50 down,  
\$7.00/mo.

## Model 1076 TV ANALYST



Actually a miniature TV broadcast station! Injects signal, produces own test pattern. Completely new, advanced design cuts servicing time in half. For black-white and color set. Does all Model 1074 does and more.

CONAR PRICE: **\$329<sup>95</sup>** \$32.34 down,  
\$28.00/mo.

**USE HANDY ORDER FORM ON PAGE 27—CASH OR TERMS**

## Features

AUTO RADIO SERVICING TECHNIQUES PART I .....	JOE GRIFFIN	3
AUDIO CABLING .....	RUSS PAVLAT	11
SINE WAVE VOLTAGE CONVERSION NOMOGRAPH .....	ALAN L. TEUBNER	15
TIME-LIMITED SWITCHES .....	RONALD L. IVES	16
AUTOMATION BY PUNCHED TAPE .....	WALLACE B. CHANDLER	24

---

## Departments

SEMICONDUCTOR REVIEW .....	JOHN POTTER SHIELDS	8
WHAT WOULD YOU HAVE DONE ? .....	GEORGE D. PHILPOTT	14
DEVICE OF THE MONTH .....	R. C. APPERSON, JR.	21
ALUMNI NEWS .....		29

---

OLIVER READ  
Editor and Publisher

ELIZABETH MORALES  
Managing Editor

J. B. STRAUGHN  
Technical Editor

T. E. ROSE  
Editor - Alumni News

RICHARD STANCHIK  
Art Editor

---



# SEASONS GREETINGS RAD-TEL'S

QUALITY

# BRAND NEW TUBE SALE!

AT LOW, LOW PRICES--COMPARE

SAVE

UP TO  
**75%**  
OFF\*



\*Manufacturers Suggested List Price

## ONE YEAR GUARANTEE

RAD-TEL WILL REPLACE ANY TUBE THAT DOES NOT GIVE EFFICIENT PERFORMANCE FOR 1 YEAR FROM DATE OF PURCHASE.

## ONE DAY SERVICE OVER 500 TYPES IN STOCK

ORDER TYPES NOT LISTED

• **FREE!** Send For New Tube & Parts Catalog  
Send For Trouble Shooting Guide

### TUBE SUBSTITUTION BOOK



**\$1.25**  
No. 193

- Over 11,000 direct tube substitutes
- Only all-inclusive directory of electron tube equivalents:
  - For USA electron tubes
  - Substitutes for foreign tubes
  - Picture tubes, newer models
  - Picture tubes, older models
  - transistor replacements
  - Army-Navy, V.T. substitutes



### CHEATER CORD

6 ft., No. 154 **29¢ ea.** Lots of 3—25¢ ea.

Easy to work on set while panel is off.



## RAD-TEL TUBE CO. TV, RADIO AND HI-FI

DEPT. NR. 55 CHAMBERS STREET, NEWARK, NEW JERSEY 07105

TERMS: 25% deposit must accompany all orders, balance C.O.D. Orders under \$5. add \$1 handling charge plus postage. Orders over \$5. plus postage. Approx. 8 tubes per 1 lb. Subject to prior sale. No C.O.D.'s outside continental U.S.A.

### EACH TUBE ATTRACTIVELY BOXED & BRANDED 'RAD-TEL'

Qty.	Type	Price	Qty.	Type	Price	Qty.	Type	Price
024		.79	6AU8	.87	6K6	.63	12CU5	.58
1AX2		.62	6AV6	.41	6S4	.52	12CU6	1.06
1B3		.79	6AW8	.90	6SA7GT	.99	12CX6	.54
1DN5		.55	6AX4	.66	6SH7	1.02	12D4	.69
1G3		.79	6AX5	.74	6SJ7	.88	12DE8	.83
1J3		.79	6BA6	.50	6SK7GT	.95	12DL8	.88
1K3		.79	6BC5	.61	6SL7GT	.84	12DQ6	1.04
1R5		.77	6BC8	1.04	6SN7	.65	12DS7	.84
1S5		.75	6BE6	.55	6SQ7Q7	.94	12DT5	.76
1T4		.72	6BF5	.90	6T4	.99	12DT7	.79
1U5		.65	6BF6	.44	6T8	.85	12DT8	.78
1X2B		.82	6BG6	1.70	6U8	.83	12DW8	.89
2AF4		.96	6BH8	.98	6V6GT	.54	12DZ6	.62
3AL5		.46	6BJ6	.65	6W4	.61	12ED5	.62
3AU6		.54	6BJ7	.79	6W6	.71	12EG6	.62
3AV6		.42	6BK7	.85	6X4	.41	12EK6	.62
3BC5		.63	6BL7	1.09	6X8	.80	12EL6	.50
3BN6		.75	6BN6	.74	7A8	.68	12EZ6	.57
3BU8		.78	6BQ6	1.12	7AU7	.65	12F8	.66
3BY6		.58	6BQ7	1.00	7EY6	.75	12FA6	.79
3BZ6		.56	6BU8	.70	7Y4	.69	12FM6	.50
3CB6		.56	6BX7	1.11	8AU8	.90	12FR8	.97
3C56		.58	6BZ6	.55	8AW8	.93	12FX8	.90
3DG4		.85	6BZ7	1.03	8BQ5	.60	12GC6	1.06
3DK6		.60	6CA	.45	8C67	.63	12J8	.84
3DT6		.54	6CB6	.55	8CM7	.70	12K5	.75
3GK5		.99	6CD6	1.51	8CN7	.97	12L6	.73
3Q4		.63	6CC7	.61	8CS7	.74	12SF7	.69
3S4		.75	6CC8	.80	8EB8	.94	12SK7GT	.95
3V4		.63	6CL8	.79	8FQ7	.56	12SL7	.80
4BQ7		1.01	6CM7	.69	9CL8	.79	12SN7	.67
4CS6		.61	6CN7	.70	11CY7	.75	12SQ7GT	.91
4DT6		.55	6CQ8	.92	12A4	.60	12U7	.62
4GM6		.60	6CR6	.60	12AB5	.60	12V6	.63
5AM8		.79	6CS6	.57	12AC6	.55	12W6	.71
5AN8		.90	6CS7	.69	12AD6	.57	12X4	.47

### RAD-TEL TUBE CO. NOT AFFILIATED WITH ANY OTHER MAIL ORDER TUBE COMPANY

5AQ5	.54	6CU5	.58	12AE6	.50	17AX4	.67
5AT8	.83	6CU6	1.08	12AE7	.94	17DQ6	1.06
5BK7	.86	6CYS	.70	12AF3	.73	18FW6	.49
5BQ7	1.01	6CY7	.71	12AF6	.67	18FX6	.53
5BR8	.83	6DA4	.68	12AJ6	.62	18FY6	.50
5CG8	.81	6DE6	.61	12AL5	.47	19AU4	.87
5CL8	.76	6DG6	.62	12AL8	.95	19BG6	1.39
5CQ8	.84	6DJ8	1.21	12AQ5	.60	19EA8	.79
5EA8	.80	6DK6	.59	12AT6	.50	19T8	.85
5EU8	.80	6DN6	1.55	12AT7	.76	21EX6	1.49
5J6	.72	6DQ6	1.10	12AU6	.51	25AX4	.70
5T8	.86	6DT5	.81	12AU7	.61	25C5	.53
5U4	.60	6DT6	.53	12AV6	.41	25CA5	.59
5UB	.84	6DT8	.94	12AV7	.82	25CQ6	1.52
5V6	.56	6EAB	.79	12AX4	.67	25CU6	1.11
5X8	.82	6EB5	.73	12AX7	.63	25DN6	1.42
5Y3	.46	6EB8	.94	12AY7	1.44	25EH5	.55
6AB4	.46	6EM5	.77	12AZ7	.86	25L6	.57
6AC7	.96	6EM7	.82	12B4	.68	25W4	.68
6AF4	1.01	6EU8	.79	12BQ6	.50	32ET5	.55
6AG5	.70	6EV5	.75	12BE6	.53	35C5	.51
6AH4	.81	6EW6	.57	12BF6	.60	35L6	.60
6AH6	1.10	6EY6	.75	12BH7	.77	35W4	.42
6AK5	.95	6FG7	.69	12BK5	1.00	35Z5	.60
6ALS	.17	6FV8	.79	12BL6	.56	36AM3	.36
6AM8	.78	6GH8	.80	12BQ6	1.16	50B5	.69
6AQ5	.53	6GK5	.61	12BR7	.74	50C5	.53
6AS5	.60	6GK6	.79	12BV7	.76	50EH5	.55
6AT6	.49	6GN8	.94	12BW7	.77	50L6	.61
6AT8	.86	6H6	.58	12BZ5	.86	70L7	.97
6AU4	.85	6J5GT	.51	12CN5	.56	117Z3	.85
6AU6	.52	6J6	.71	12CR6	.67	807	.75

Fast, Dependable Service — Selling direct by mail for over 16 years —

RAD-TEL Tube Co.  
Dept NR  
55 Chambers Street  
Newark, New Jersey 07105

ENCLOSED IS \$ \_\_\_\_\_ Please rush order.

SEND: \_\_\_\_\_ TUBE SUBSTITUTION BOOK, No. 193 @ 1.25 EACH  
\_\_\_\_\_ Cheater Cord 29¢ ea. Lots of 3 - 25¢ ea. #154

Orders under \$5.00 - Add \$1.00 handling charge - plus postage.

**FREE!**  Send FREE Tube and Parts Catalog  
 Send FREE Trouble Shooting Guide

NAME \_\_\_\_\_  
ADDRESS \_\_\_\_\_  
CITY \_\_\_\_\_ ZONE \_\_\_\_\_ STATE \_\_\_\_\_



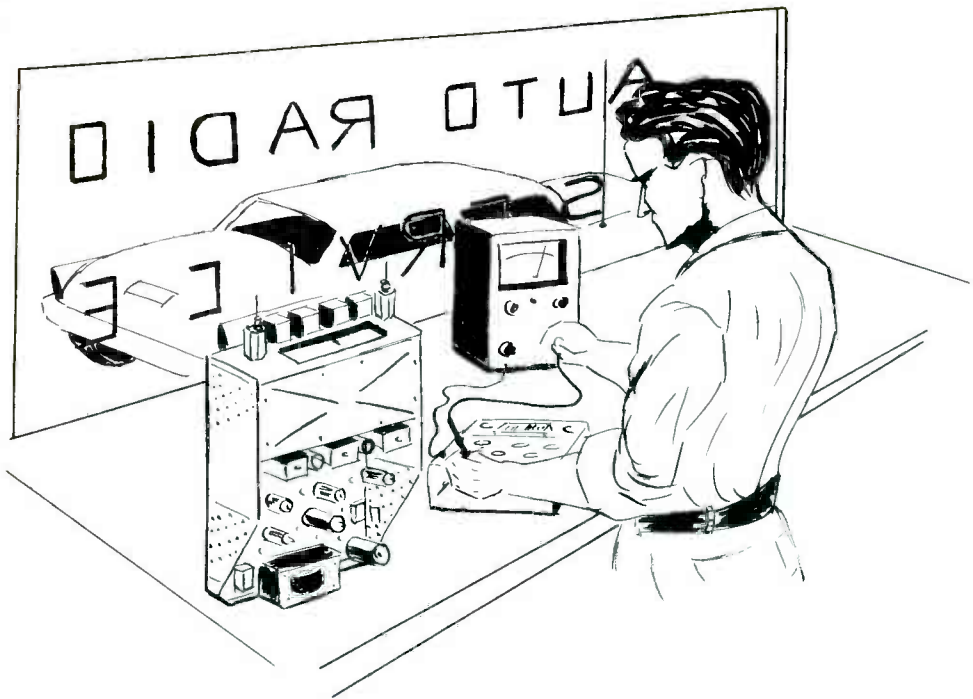

# AUTO RADIO SERVICING TECHNIQUES

PART I OF A TWO-PART ARTICLE

BY JOE GRIFFIN

**A** serviceman just entering into the auto radio servicing field will find automobile radios quite different from home receivers. Auto radios require different operating voltages and currents, greater sensitivity, selectivity, ease of tuning, and more rugged construction and effective shielding. These differences are imposed by the conditions under which they must perform.

Auto radios are in a constantly moving environment which not only subjects them to mechanical shock, but also causes them to operate under conditions of varying signal strength. Furthermore, the electrical system of the car subjects the radio to interference not usually found at home receiver locations. From the foregoing you can see that auto radios not only are subject to breakdown more frequently than home radios, but also require more precise servicing

## TYPES OF AUTO RADIOS

Today the serviceman will also find himself confronted with several different types of auto radios. Cars today may be equipped with vibrator-powered sets, transistor-inverter-powered sets, hybrid sets (that use both tubes and transistors) and fully transistorized sets. Many cars may also have either an FM tuner, or an FM radio in addition to the AM set.

While all new cars sold today that come equipped with radios have transistorized sets, many older model cars have tube radios that use a vibrator, while many others contain hybrid sets.

Except for the power supply (in sets that use a vibrator) the same basic functions are performed by the same basic stages in all types of auto radios. However, the manner in which

they are performed, as well as the circuits used to produce these functions may differ.

### THE VIBRATOR POWER SUPPLY

A typical modern vibrator power supply is shown in Fig. 1. In some cars this may be mounted on the chassis with the rest of the circuits, while in others it may be mounted on a separate chassis which can be removed from the car for servicing without disturbing the rest of the radio.

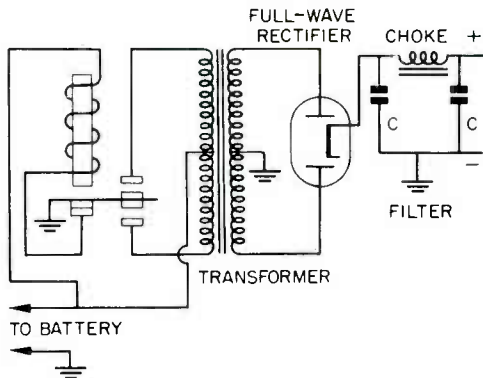

FIG. 1. Complete vibrator B+ supply.

Fig. 2 shows a cutaway view of a vibrator. The parts are: (1) the frame, (2) the driving coil and driving coil contact, (3) the armature "reed" which carries the moving contacts, (4) the stationary contacts, on smaller reeds, (5) the stack, which consists of insulators and plates bolted together to hold the whole assembly in rigid alignment, and (6) the base.

### TYPICAL TROUBLES IN VIBRATOR POWER SUPPLIES

Troubles in a vibrator supply may be caused by a defect in any of the following component parts: (1) The vibrator, which may stick causing the fuse to blow, or may have burned contact points which will cause noise in the receiver output. (2) The transformer, in which an open or shorted winding will result in a loss of voltage. If the winding is partially open or shorted the voltage will be greatly reduced causing the receiver to be weak, or dead. (3) The filter choke which, if open, will result in loss of B+ voltage to the screen grid and plate circuits. A shorted filter choke will result in hum from the receiver. (4) The filter capacitors which, if open, will result in lowered B+ voltage and hum. A shorted output filter capacitor will cause loss of plate and screen voltage whereas a shorted input capacitor will result in complete loss of B+ voltage. (5) The rectifier tube, in which the

filament may burn out or short. The cathode lead inside the tube may open, in which case the set will be dead although the filament will remain lighted.

You can begin servicing a vibrator power supply by checking the B+ voltage at the cathode of the rectifier tube. If you fail to obtain a reading on your voltmeter at this point, and the vibrator is buzzing, replace the rectifier tube. If there is still no B+ voltage, check for an open primary or secondary winding in the transformer, or an open center tap connection to ground. If you obtain a very low B+ voltage reading after replacing the rectifier tube, or if the fuse blows after the set has been operating for a few seconds, check the buffer capacitor for a short. If you measure normal B+ voltage at the cathode of the rectifier tube, but no voltage at the output side of the filter choke, the choke is open. A voltage reading much lower than normal at both the cathode of the rectifier and at the output of the filter indicates that one of the filter capacitors is shorted, or a part is shorted in the plate or screen grid circuit. You can determine if a filter capacitor is shorted by disconnecting one of its leads and

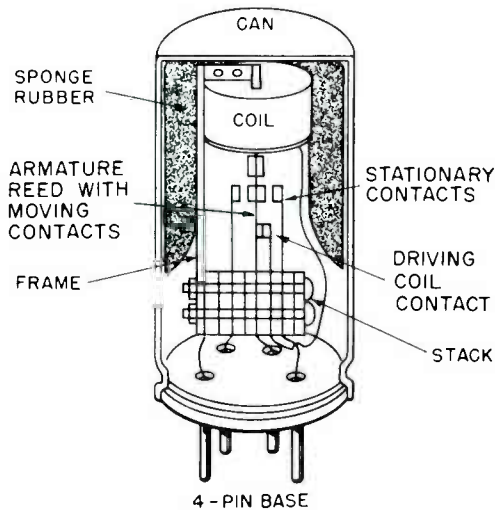

FIG. 2. A modern vibrator.

watching your voltmeter. If the voltage rises to almost normal, the capacitor is shorted. If the voltage remains the same, disconnect the lead of the other filter capacitor and watch for a rise in voltage. If it does not rise, a part is shorted in the plate or screen grid circuit.

If the voltage is abnormally low, and the set has a loud hum, check for an open filter capacitor. Do this by bridging a good electro-

lytic capacitor across each filter capacitor. If the hum stops or decreases appreciably, replace the capacitor. Replace both filter capacitors whenever one is defective.

### SERVICING IN THE CAR

Many small jobs can be done in the car, such as replacing tubes, vibrators, or a loudspeaker that is mounted apart from the set. Also, all work on the antenna, connecting cables, fuse, and any other part that is a part of the car itself, can be done without removing the radio.

There is a certain order which you should follow when making tests in the car. This will enable you to determine, in the shortest possible time, whether you can make the necessary repairs in the car, or if you will have to remove the set. First, determine if the set is receiving power from the battery. Turn the radio on and listen carefully for noises that indicate that the set is receiving power. You have to turn the ignition switch on in some cars before the radio can receive power from the battery. If the set uses a vibrator, you should hear mechanical noise and see the dial lamps lighted.

In a transistor set, you should hear a thumping sound from the loudspeaker when the switch is first turned on. In a hybrid radio, the dial lamps should light and you should hear a thump in the loudspeaker.

If the above tests fail, check the fuse and fuse holder. If the fuse is OK, check for voltage at the hot end of the fuse holder by measuring it with your voltmeter. You should obtain a reading that is approximately the same as the full battery voltage. If there is no voltage, check the terminal connections on the ignition switch, and the lead from the ignition switch to the fuse holder.

If a transistor radio is receiving power from the car battery, but does not operate, listen for a hissing sound from the loudspeaker. If you can hear a hiss, the antenna may be defective. Check this by substituting a test antenna. If the set still does not operate, remove it to the bench for servicing.

In a hybrid radio that is getting power from the battery, as indicated by a lighted dial lamp, but from which you can hear no sound, check the loudspeaker if it is accessible. If it is OK, remove the cover from the set and pull the first audio tube (if the set uses transistors in the power output stages only), or pull the second i-f tube if the set uses a transistor in the first audio stage. If you hear a pop in the loudspeaker, these stages are OK.

Next, pull each of the remaining tubes from the sockets, and listen for a pop as you remove each tube. If you remove a tube that fails to produce a pop, either that tube is defective, or a component part in that stage is defective. If you obtain a pop from each tube as you remove it from its socket, then pull the antenna plug from its socket. If you do not hear a pop, the antenna is probably defective. If none of these tests reveal the trouble, you will have to remove the set for bench servicing.

There is no definite procedure for removing a car radio because of the many different types of installations. You will have to depend upon the removal instructions in the servicing information for the radio until you become familiar with the different types of installations.

### BENCH SERVICING AUTOMOBILE RADIOS

The test bench should have a source of power for operating both six- and twelve-volt radios from batteries or a battery eliminator. If batteries are used, you should have a 0-15-ampere meter in series with one of the battery leads and a voltmeter across the batteries to enable you to read the voltage and the current drain of the set. If a battery eliminator is used, the output should be well filtered for operating transistor receivers. Another useful item is a separate test speaker mounted near your service bench.

First, determine whether the radio requires six or twelve volts, and whether it is grounded to the positive or negative side of the power supply. This is very important, in servicing transistor radios, so either note the battery in the car from which the radio is removed, or consult the schematic diagram for the set, to determine the proper polarity.

When servicing transistor or hybrid radios, always make certain that the speaker is connected before turning the set on. Otherwise the transistor output stage, or stages, will not be loaded and the transistors will be damaged. Use a speaker that matches the receiver output impedance.

### TYPICAL TROUBLES IN AUTO RADIOS

The set may be dead, weak, noisy, intermittent, it may oscillate, or it may have distorted audio output. The exact servicing procedure to use for a given trouble will depend upon the nature of the trouble, and the type of receiver involved. You can use circuit disturbance, signal tracing, or signal injection methods to service a dead receiver.

There are certain preliminary checks to make for any of the above troubles. Make a quick visual inspection for surface defects, such as broken leads, loose connections, tubes or transistors out of sockets, etc. Check the overall current drain of the set, as well as the operating voltage supply. If these preliminary steps do not lead you directly to the defect that causes the trouble, you will have to use a localizing procedure to isolate the defect to a stage, or a circuit.

### LOCALIZING DEFECTS

Whether an automobile radio uses tubes, transistors, or a combination of the two, it can be divided first into sections (rf, af, power

A circuit disturbance test is one of the most effective methods for isolating defects in a dead receiver. If the receiver uses vacuum tubes exclusively, you can disturb each circuit by touching the control grid of each tube with a thin bladed screwdriver, while holding the metal part of the screwdriver. To isolate the defect to either the rf or the af section, turn the volume control fully clockwise and touch the hot side of the volume control with the screwdriver blade and listen for a hum in the loudspeaker. A loud hum tells that the audio section is operating so the defect must be in the rf section. If you do not obtain hum, the audio section is at fault. If you isolate the trouble to the audio section, touch the control

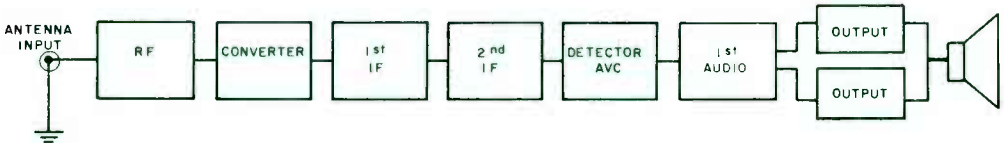

FIG. 3. A block diagram of a typical superheterodyne AM auto receiver.

supply) and then into stages and circuits,

A block diagram of a typical superheterodyne AM auto receiver is shown in Fig. 3. The stages in this set are the rf amplifier, the converter, the first and second i-f amplifiers, the second detector and avc, the first af amplifier, and push-pull power output. You can localize a defect to one section (rf or af) either by tracing it to that section, or by determining that the other section is operating properly. If you cannot go directly to the defective part after you have isolated the trouble to one section, you will have to make further tests to localize the trouble to one stage, or even to one circuit. Once you have isolated the trouble to a stage, you make voltage measurements to locate the defective circuit, and then resistance measurements to locate the defective part. Always make sure the set is turned off before you make any resistance measurements.

Circuit disturbance, signal tracing, and signal injection methods can be used to locate a defective stage in a dead receiver. Signal tracing and signal injection methods can also be used to locate a defect that causes distortion or to check a weak receiver. If a defect causes hum or noise, or causes the receiver to operate intermittently, you can use the stage blocking method to locate the defect. You can also use the signal tracing method to locate these defects, as well as to locate the cause of oscillation.

grid of the second af tube. Failure to obtain hum indicates that the trouble is in either the tube itself, the output transformer, the loudspeaker, or a component part in the second audio stage. Replace the tube and if this does not restore operation of the set, check the primary winding of the output transformer with your ohmmeter for an open. If the primary winding checks OK, disconnect one of the secondary leads from the speaker voice coil and check for an open voice coil or an open transformer secondary winding. If none of these checks reveal the defective part, check the operating voltages of the second af stage. An abnormal voltage reading in the plate, screen grid, cathode, or control grid circuit indicates a defect in that circuit. Turn the set off and use your ohmmeter to check for shorted resistors, capacitors, wires, as well as for open resistors, or resistors that may have changed value. You can check for open capacitors by bridging a suspected capacitor with a good one, while the set is operating.

If you hear hum in the loudspeaker when you touch the control grid of the second af tube, the stage is OK. Next, touch the control grid of the first af tube. If you do not obtain hum, replace the tube. If this does not correct the trouble, check the coupling capacitor between the first and second audio stages, the plate load resistor, and the cathode resistor. One of these parts should be defective.

If you do obtain hum when you touch the con-



trol grid of the first af tube, but not when you touch the hot side of the volume control, the volume control or the coupling capacitor between the wiper arm of the volume control and the first af tube control grid is open.

Next, touch the control grid of the second i-f tube. If this does not cause hum, replace the tube. If still no hum, check the i-f transformer for an open or shorted primary or secondary winding. Most sets use a multi-purpose tube for the second detector and first af. If you checked or replaced such a tube when you checked the first af stage, you can eliminate the second detector tube as being defective.

If you hear hum when you touch the control grid of the second i-f tube, touch the control grid of the first i-f tube. If you do not obtain hum now, replace the first i-f tube. Check the second i-f transformer for open or shorted windings, measure the operating voltages and, if abnormal, check for open, shorted, or incorrect value of component parts.

If the first i-f stage checks OK, touch the signal grid of the converter tube. If you do not obtain hum, replace the tube and check the transformer. If you do hear hum, next, touch the control grid of the rf amplifier tube. If no hum, replace, and check the rf coupling capacitor, or transformer, whichever the set uses. Next, check the antenna by touching the antenna terminal with the screwdriver blade. If none of these checks reveal a defect, the local oscillator may not be oscillating. To check this, measure the negative voltage on the grid of the oscillator tube. If there is no voltage it is not operating. If you replaced the tube when you checked the converter stage, check the operating voltages of the oscillator stage and check for defective component parts in the grid, plate, or cathode circuits. One of these checks will reveal the defect.

You cannot make an effective circuit disturbance test in a dead transistor radio by touching the electrodes with a screwdriver because of the low impedance of the transistor stages. However, you can use your ohmmeter (or the ohmmeter of your VTVM) to increase the forward bias of a transistor stage to disturb the circuit. If the set uses PNP type transistors, connect the positive lead of the ohmmeter to the positive terminal of the battery and touch the base electrode with the tip of the negative lead. If the set uses NPN transistors, reverse the leads. Always use the lowest range of your ohmmeter.

Instead of a humming sound, you will hear a click from the loudspeaker when you touch the transistor base with the tip of the ohmmeter lead, if everything between the point touched

and the loudspeaker is operating. You can isolate the trouble to either the rf or the af section by touching the tip of the ohmmeter lead to the hot side of the volume control. Once you have isolated the trouble to a section, check each stage working toward the antenna. The point at which you do not obtain a click indicates that you have just passed over the defective stage.

To make a circuit disturbance test on a dead hybrid radio, touch the control grids of the tubes with the screwdriver and use the batteries in your ohmmeter to disturb the transistor stages. The procedure is otherwise the same as that used for the tube, or the transistor radio.

### WEAK RECEIVER

To check a tube set, check the tubes, then the coupling capacitor between the first and second af stages. If none of these parts is defective, you will have to use an isolating procedure. In a weak transistor receiver, first check all electrolytic capacitors for opens by shunting a capacitor of the same type across each suspected unit. Be sure to connect the test capacitor with the same polarity as the original. If this fails to reveal the defect, check the alignment of the receiver. If the set is not misaligned, you will have to use an isolation method.

Part II will appear next month.

Most of life is routine -- dull and grubby, but routine is the momentum that keeps a man going. If you wait for inspiration you'll be standing on the corner after the parade is a mile down the street.

Ben Nicholas



"Can't you tell by now whether you got the right tube?"

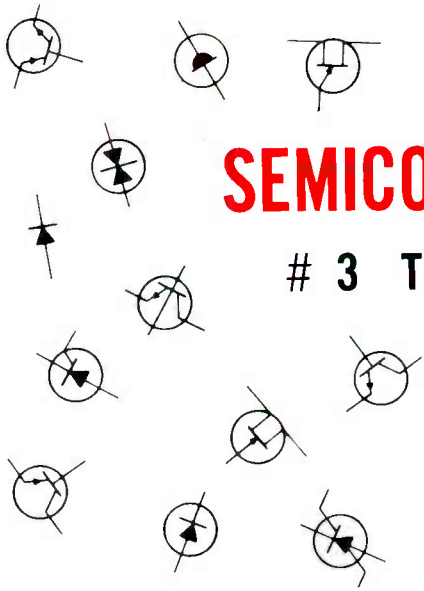

# SEMICONDUCTOR REVIEW

## # 3 The Hall Effect

BY

JOHN POTTER SHIELDS

This month, we're going to talk a bit about the "Hall Effect", an interesting electrical/magnetic phenomenon which occurs in various metals, and to a much greater extent in certain semiconductors.

The Hall Effect is named after its discoverer, Edward H. Hall, who in 1878 discovered that a minute voltage appeared at the edges of a thin metal strip through which current was flowing when the strip was in the presence of a strong magnetic field. See Fig. 1. Although Hall's phenomenon was an interesting scientific curiosity, it found little application until just a few years ago when solid state crystals such as indium antimonide and indium arsenide (which passes usable Hall Effect efficiencies) was discovered.

Reduced to its simplest explanation, the Hall Effect is observed when a current-carrying conductor is placed in a magnetic field perpendicular to the direction of current flow. A voltage, known as the Hall voltage, perpendicular to both the magnetic field and current directions will be developed across the conductor.

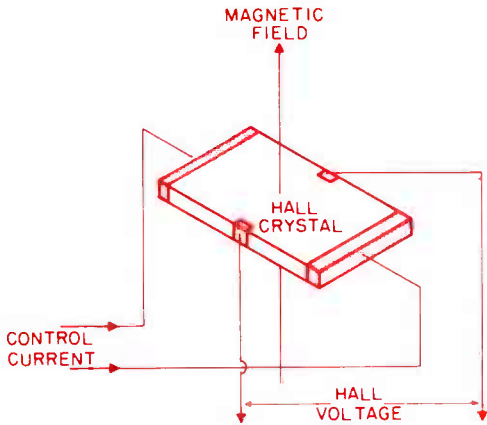

FIG. 1. Basic Hall Effect.

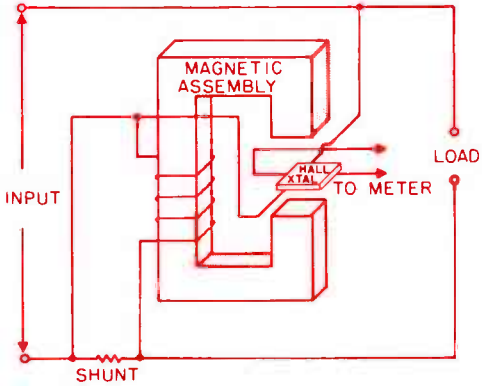

FIG. 2. Basic Hall Effect ammeter.

One of the most useful properties of Hall Effect is that the developed Hall voltage is proportional to the product of the magnetic field density and current flowing through the conductor. This property suggests a number of practical applications for the Hall device including ammeters (Fig. 2) and analog signal multipliers. Another obvious Hall device application is that of measuring magnetic field strengths. A major advantage of this arrangement is that there need not be any relative motion between the Hall device and the magnetic field. All conventional magnetic field intensity measurements require relative motion between the field sensing device and the

magnetic field. Along these lines, magnetic field measuring devices (magnetometers) have been designed with full scale capabilities up to 10 kilogauss with accuracies of better than 1%.

Modern solid state Hall Effect devices are capable of operation from DC well into the microwave region. This being the case, Hall Effect devices may be used efficiently as frequency converters. In this arrangement, one frequency is used as the Hall device control current (being passed through the Hall semiconductor crystal) while the other frequency is applied to a coil which supplies a magnetic field to the crystal. The resultant Hall voltage will contain the sum and difference frequencies of the two input frequencies. An interesting feature of this arrangement is that the Hall voltage contains only the sum and difference frequencies ... with no higher or lower harmonics as is the case in conventional frequency converters.

The Hall Effect device can also be used to advantage as a low level chopper ... a device for converting low level DC signals to corresponding AC signals for ease of amplification. In this arrangement, the low level DC signal to be chopped is applied as the control current to a Hall Effect crystal and, the AC chopping signal is a magnetic field-producing coil into which the crystal is inserted. This type of chopper has many advantages over a corresponding mechanical unit because no wear producing make and break contacts are involved. Also, it will operate at much higher frequencies.

Hall Effect devices may also be used as displacement indicators due to the fact that the generated Hall voltage is dependent upon the distance between the Hall device and the magnetic field.

Devices which could make use of this Hall Effect characteristic include tachometers, proximity detectors, relays, and contactless switches. As mentioned earlier, no relative motion is required between the magnetic field and Hall device to produce an output signal. Thus, in the case of a displacement measuring device employing a Hall unit, it is unnecessary for either the Hall unit or magnetic field to be in motion ... a definite advantage over many standard proximity sensing devices.

### MAGNETORESISTIVE DEVICES

Before leaving the topic of Hall Effect devices, a word or two is in order on the magnetoresistor, a close cousin to the Hall Effect units.

Basically, a magnetoresistive device is a semiconductor, such as indium antimonide, whose resistance varies in the presence of an applied magnetic field.

Applications for the magnetoresistor include stepless audio and video gain controls, L and T pads, rf attenuators etc. In each of these cases, control of resistance is by means of an externally applied magnetic field.

Here's a rather interesting photocell circuit that should serve to tickle your imagination ... a light-operated tone generator. Its applications include a "daylight alarm", photo-theremin, illumination monitor, and what have you.

Fig. 3 is the gadget's circuit. As you can see, it is basically a blocking oscillator with a photoresistive photocell (Lafayette Radio No. MS-922) forming a portion of the transistor's base bias circuit. In operation, the photocell's resistance will vary with applied illumination, thereby changing Q1's base bias and hence operation frequency. The circuit and its component values are not at all critical.

The next photocell circuit, Fig. 4, is a "static switch" which requires no relay to actuate the external load circuit. Incidentally, this is an excellent circuit to demonstrate basic industrial static switching circuitry. The photoresistive photocell is connected into the base bias circuit of the power transistor, Q2, in such a manner that light striking the cell will cause an increase in Q2's base current, and hence its collector current. The No. 47 pilot light, "external load" placed in Q2's collector circuit will now light brightly when the cell is illuminated and be completely extinguished with no light striking the cell. If desired, a 6-volt bell or buzzer may be substituted for the pilot light.

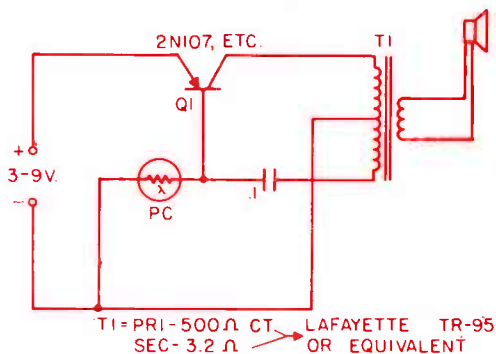

FIG. 3. Light-operated tone generator circuit.

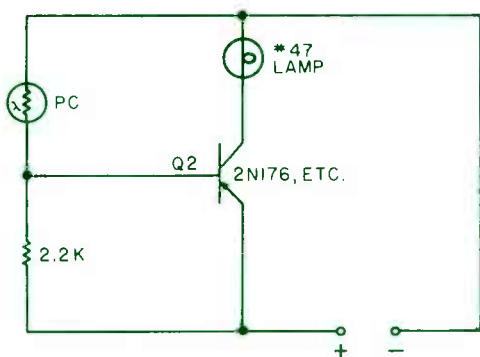

FIG. 4. Photoresistive photo cell connected as a static switch.

### NEW SEMICONDUCTOR PRODUCTS

While you probably won't be coming across the following two new items in your routine service work for some time yet, they are nevertheless of considerable interest. The first is a new Gallium Arsenide infrared light source just recently announced by Texas Instruments.

This new IR light source (type SNX-NO) is capable of a continuous optical output of 2 milliwatts at 25°C. with a forward bias current of 2 amperes.

Output ratings of this new unit are approximately 100 times greater than previous units, and there is a significant improvement in both light emission efficiency and current handling capability. Usable light output, as a function of input current, has been increased by a factor of five by forming and optically polishing the diode into the shape of a hemisphere.

Peak radiant emission of the new unit occurs at a wavelength of .92 micron at -195° centi-



Texas Instruments SNX-NO light source.

grade. The spectral output of the SNX-110 falls within the high sensitivity region of silicon, germanium, and suitably prepared cadmium selenide detectors such as the Clairex type CL5041.

A sub-microsecond response time makes possible the amplitude modulation of this new

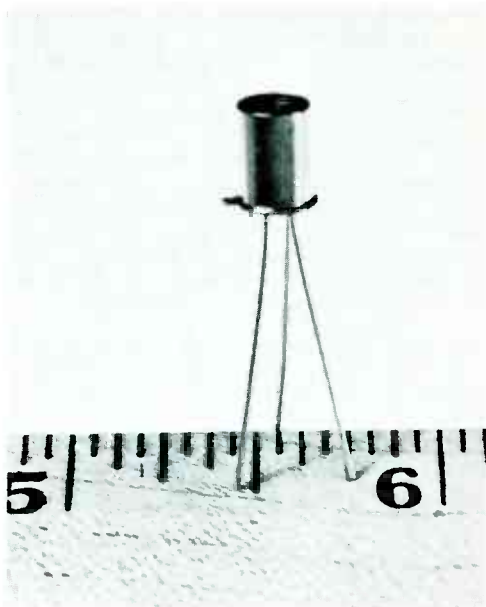

CBS Laboratories ultra-fast laser detector.

unit at high frequencies, thus making possible its utilization in line-of-sight communications. It also serves as a light source for high-speed photography, ultra-fast stroboscopes, and light-actuated silicon controlled rectifiers.

The next item is an ultra-fast response time laser detector currently being produced by CBS Laboratories, a Division of Columbia Broadcasting System, Inc. The new photo device features extremely low leakage currents under conditions of high reverse bias.

Well, that's just about it for now. See you next month.

38

USE CHRISTMAS SEALS

FIGHT  
TB  
AND  
OTHER



RESPIRATORY DISEASES



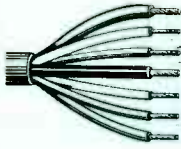

A PROFESSIONAL SOUND

# AUDIO CABLING

ENGINEER REVEALS SOME TRADE SECRETS

BY RUSS PAVLAT

The use of sound systems in business and industry is increasing rapidly. An important part of the sound system installation is the cabling required to perform various functions. A practical knowledge of the operation of the sound system cabling will enable the radio and sound technician to do a better installation job and subsequently a better maintenance job. Information is needed on the kinds of cable in use, the general purpose for which they are used, the basic ways in which they operate, and the proper methods of installation and maintenance to assure maximum service.

Single wires are used rarely. Any single wire audio or audio control circuit requires the use of a good ground return system. Generally, building grounds and conduit grounds are not dependable, and even if a system can be made to function properly when installed, the use of a single wire is a poor gamble, because grounds tend to become unreliable with age.

An unshielded twisted wire pair or multiple unshielded twisted wire pairs are frequently used in balanced line intercom systems, intercom control and telephone communications. A single unshielded wire pair may also be used between the output of an audio amplifier and a speaker and may operate at voice coil impedances or on a constant voltage or constant impedance line. Multiple unshielded twisted pairs may be used in cable or in conduit for this purpose if the same program is being transmitted simultaneously to a num-



CONDUCTIVE COTTON



FOIL SHIELD

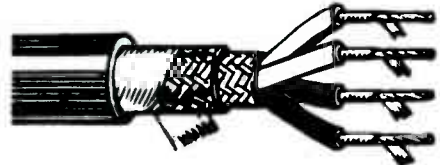

BRAIDED SHIELD



SPIRAL SHIELD

*Courtesy Belden*

Representative cables designed especially for sound distribution systems.

ber of speakers. If different programs are being transmitted simultaneously to a number of speakers, unshielded pairs should not be used, since the probability of cross-talk is high.

Microphone cabling is always shielded and some slight decrease in shield effectiveness may be tolerated to obtain a very flexible cable from the microphone to the wall outlet or amplifier input.

Intercom system cabling usually is a combination of shielded pairs for audio circuits and unshielded pairs for control circuits.

The most used wire sizes are from No. 18 to No. 22. In general, the lower the impedance and the longer the circuit, the larger the wire size. The loop resistance of 500 feet of 2-wire No. 18 is about 8 ohms and if a speaker within 8 ohms impedance was hooked to the end of this line, half of the power put into the line would be absorbed by the line. To reduce losses on long lines, higher impedance lines and matching transformers at speakers are used.

Common audio voltages encountered are 25 and 70 volts. Long and high-powered lines may be rated at 141 or 282 volts and the cable must be rated at, or above, the voltage used.

There are four types of shielded cable in common use today:

**1. TINNED COPPER BRAID.** This shielding provides 80 to 85% coverage, is relatively easy to bend, flexed or twisted, but is relatively difficult to handle when soldering to connectors. It is frequently used in microphone leads from the microphone to the wall outlet or amplifier input.

**2. SPIRAL WRAP.** This shielding provides 90% coverage and is designed for stationary service since repeated bending causes shield separation. It is frequently used for microphone, intercom and speaker leads in conduit, or in fixed locations. It is easy to handle and to solder.

**3. CONDUCTIVE COTTON PLUS DRAIN WIRE.** This shielding provides 100% coverage, is very flexible, easy to solder because of the drain wire, but is easily damaged by abrasion. It is commonly used in multiple pair cables.

**4. FOIL ON PLASTIC WITH DRAIN WIRE.** This shielding provides 100% coverage, has medium flexibility, is easy to solder and in general is used for stationary service or inside conduit. If the foil is applied with the

plastic surface out, this type of shielding can isolate individual pairs in a multi-paired cable.

The term coverage as used above means physical coverage of the conductor insulation with a conductive material but does not express the percentage of effectiveness against outside interference. The protection a shielded cable gives against outside interference depends upon the shielding material used and the physical position of the cable conductors relative to the sources of interference.

Shielding should never be used as a conductor. It should be considered a protection against interference and not an active element in the transmitting of audio power.

Bare shield should never be installed in metallic conduit. A plastic or rubber overall covering should always be between the shielding and the conduit. The elements in tinned copper shields react quickly with other metals in the presence of impurities and moisture, and corrosion is rapid, causing noise and breaks in the shielding. The dissimilar metals, impurities and moisture may actually form small battery-like cells which increase the rate of deterioration. Audio currents in the wires within the shielding induce current flow in the shield material causing noise and further rapid breakdown at points of contact with the conduit. The overall covering also insulates the shields of individual cables from each other to reduce noise and corrosion.

Two types of externally caused interference cause trouble on audio lines, and they are commonly called inductive and electrostatic interference.

Inductive interference is a result of transformer action. Each wire has a magnetic field around it which is building up and breaking down according to the alternating power or audio currents in it. As the magnetic field changes, lines of magnetic flux cut adjacent wires, inducing voltage and causing an interfering current flow. Ordinary shielding of copper braid or aluminum foil does not stop inductive interference at audio frequencies. The twisting of the wires (called transposition) causes cancellation of inductive interference by causing phase differences in induced voltages (because of twisting) to cancel each other. Steel conduit offers some protection against inductive interference. Wires with magnetic shielding materials are available and although expensive, they are effective, and sometimes required to solve a difficult inductive interference problem.

Electrostatic interference develops because

of the attraction between particles of unlike charge and repulsion of particles of like charge, e. g., a positively charged wire, due to momentary currents resulting from audio transmission, will attract negative electrons in an adjacent wire causing voltage build up and current flow because of the electron movement. Any metal is an electrostatic shield at audio frequencies. Here, steel conduit also offers protection. To prevent this electrostatic interference within a cable,

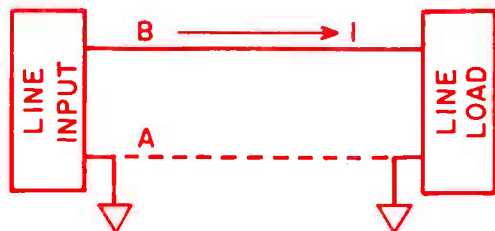

FIG. 1. Unbalanced line operation.

cable pairs should be shielded from each other.

Audio circuits operate in either unbalanced or balanced line systems. Unbalanced line operation is shown in Fig. 1. The circuit will operate whether or not line A is furnished, but since ground returns are not dependable and at best are noisy, line A should be installed. Since audio currents flow in line B at a relatively high potential above ground, line B will induce voltages both electrostatically and inductively in adjacent lines, and adjacent lines will similarly induce voltages in line B, causing system troubles.

Fig. 2 illustrates balanced line operation.



FIG. 2. Balanced line operation.

There is no current flow between ground points and a wire is not required, with the ground being only a system reference point with a center tap on the output transformer. Equal and opposite audio currents flow in lines B and C as shown, with difference voltages developed across the transformers for power transfer.

Any voltages induced electrostatically or in-

ductively by lines B and C in an adjacent wire will be opposite and equal in voltage at any given point and will cancel each other. Any voltage induced in line B and C by an adjacent wire will be the same in both lines, raising the voltage level of the system but not producing a difference voltage between lines B and C. Since only a difference voltage causes current flow, these induced voltages will not cause interference.

The effectiveness of balanced line operation depends upon the degree of balance attained, and with perfect balance, shielding would not be required. Practically, it is impossible to obtain perfect balance since no two wires can occupy exactly the same space. It is possible to attain balance to a degree which effectively limits interference, and balanced line operation using twisted shielded pairs is very satisfactory for most audio purposes.

Audio cabling is literally the "lifeline" of any audio system. Good quality cable, properly installed, can provide many years of satisfactory service. The slight additional cost of good cable and the slight additional labor required to do a good job are repaid many times by increased customer satisfaction, a good reputation, and additional and repeat business because of them.

### INSTANT SCREW AND NUT HOLDING

BY THOMAS R HASKETT

When you have to put a screw or bolt in a hole at the deep end of a recessed compartment, you may wish you had a magnetized driver. But if you have a lot of screw and nut drivers, they may not all be magnetized—or you may not want them to be. No matter, though; simply stick the driver's tip in that can of vaseline or thick grease. The sticky goo will cause most small and medium-sized screws and bolts to adhere to the driver tip. Be sure to wipe the tip off when you've driven the screw home. A bit messy, but it gets the screw in.

And if you're trying to mate a screw through a panel or two with a nut and possibly a lockwasher on the other side, it may be almost impossible to hold the nut and lockwasher so that the threads mesh. Smear some goo (vaseline, etc.) on the washer and stick it to the panel over the hole. Then smear paste on the nut and stick it to the washer. Now you need only a single-point contact on the nut to hold both it and the lockwasher in place until the screw threads run in.

# What Would You Have Done ?

TEST YOUR SERVICING  
KNOW-HOW BY MATCHING  
WITS WITH LUCKY LYTEL

BY GEORGE D. PHILPOTT

The sign of Christmas at Lucky Lytle's TV shop was the several dozen small record players and last minute service jobs that spot the season in shops around the country.

Small, cardboard-cased, uncomplicated one-tube record players were not Super-Sonic Smith's idea of sound reproduction. Repairing them needled him enough to scratch. And that was what he was doing, scratching his crew-cut as he studied an open 4-speed job on the bench before him. "Cracker-box.." he growled.

Lucky had just finished fixing two of the small phonographs and turned to see how Super-Sonic was doing. "Troubles?" he inquired.

"It's the same old story: low volume, runs a little slow, the volume control is noisy, and I don't like record-wreckers," the lad replied.

"Truthfully," said Lucky, "I don't enjoy spending a lot of time on them, myself. Still, they do serve a purpose."

Lucky told his helper, "Low cost record players appeal to the mass market in several ways. For one, the average teenager wouldn't be caught dead without one. Second, their parents often own expensive hi-fi equipment and want the kids to have their own phonos. It's cheaper from a maintenance angle, all around."

"You know, you're right, Boss," admitted Super-Sonic, "In fact I've got one at home."

"Sure, they're a popular item, Super. And when they go bad someone has to fix them. Right?"

"Well, I guess so."

"O.K. then. Now, what seems to be your pet gripe when it comes to repairing them?"

"Boss, I've had three jobs this week that didn't sound much better after I worked on them. They sounded O.K., but not enough volume."

"No problem there," Lucky replied.

"It is a problem when you spend hours before you prove to yourself that it has to be a defective cartridge crystal."

"Change the crystal first," retorted Lucky.

"That's just what I thought you'd say," said Super Sonic. "But, one half of these jobs we don't have the exact replacement, and on the other half, we're fresh out. Makes it tough to compare units."

Lucky thoughtfully replied, "Perhaps I had better give you a briefing on the speedier methods of fixing simple, 4-speed record players."

Super-Sonic blushed, but his ears came to attention. "I'm willing to learn," he said.

"In the first place, the average low price phono uses the Rochelle-salt type crystal. They're cheaper, but efficient. This means one thing when it comes to testing them for quality output: you can expect a predetermined output for a given driven input. Do you know where our 400-cycle test record is?"

Super-Sonic reached behind the oscilloscope and withdrew a dusty record. "You made this recording yourself, Boss. I remember when but not why."

"Because," said Lucky, "I don't know of one company that makes a small test record for the test I'm about to show you. Before I get ahead of myself, remember these points when checking for low volume. Speakers will lose magnetism and this means loss of volume. The tube may be weak or shorted. Selenium rectifiers often go sour. Or, filter capacitors may dry out and become open. I've found partially shorted output transformers, primary or secondary windings. After these components have been checked - and it doesn't take long - the crystal is the most likely suspect. You know how to test the amplifier. Right?"

"Right."

Lucky reached for the VTVM test leads, said, "Let me show you my way of testing pickups, crystal and ceramic."

WHAT WOULD YOU HAVE DONE?

Answer on page 32.



# SINE WAVE VOLTAGE CONVERSION NOMOGRAPH

BY ALAN L. TEUBNER

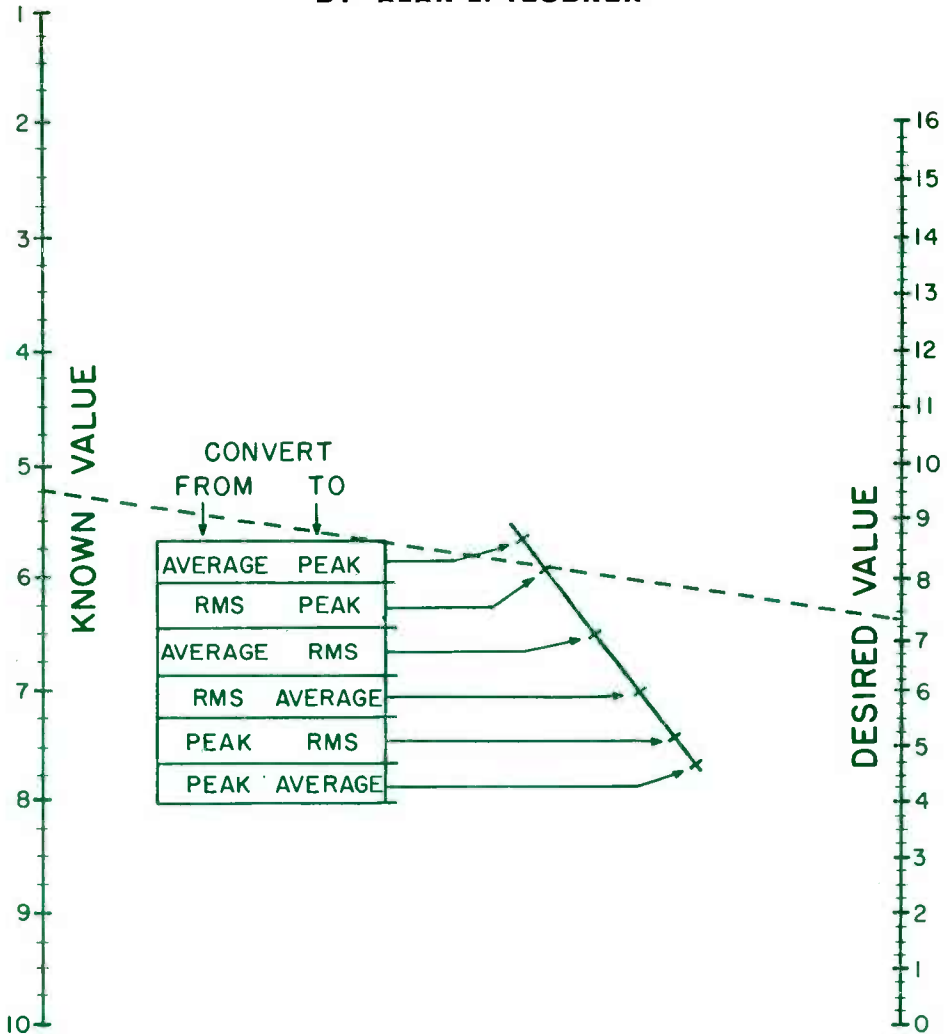

**D**o you have trouble remembering all those conversion factors for sinusoidal voltages? Most of us can remember one or two, but in the day-to-day calculations we do waste a lot of time either looking them up or figuring them out. This nomograph will solve that problem. It's quicker to use than even a slide rule, for this particular problem.

To convert from one value of an AC voltage to another, it is necessary only to draw one line. First find the numerical value of the voltage reading you now have on the left-hand scale, labelled "KNOWN VALUE". Then locate the point on the small scale in the center that corresponds to the conversion

you want to make. Draw a straight line between these two points and continue it until it crosses the right-hand scale, labelled "DESIRED VALUE". The point where the line crosses this scale gives you the answer.

An example is already drawn on the chart. Assume that you have a sinusoidal voltage that is 52 volts, rms, and you want to know its peak value. Draw a line from 5.2 on the known value scale through the second graduation from the top on the center scale, which is marked RMS-PEAK, and intersecting the desired value scale. In this case the answer is 73.5 volts. Notice that both scales together can be multiplied by any power of ten.

# TIME-LIMITED SWITCHES

AN UP-TO-DATE REVIEW OF  
SEVERAL TIMER CIRCUITS  
USED IN HOME AND INDUSTRY

BY RONALD L. IVES

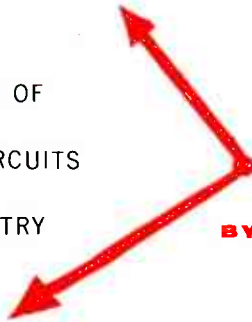

One of the recurrent needs in industrial electronics is for a switching device which, when actuated by a clock contact or push button, will operate a device for a definite time, and then shut itself off. Most familiar device of this type is the "hang" switch, a fairly standard electrical item, which delays a lamp shutoff for several seconds.

Time-limited switching devices are not at all new, and there are many types, each best suited for some specific group of requirements. Where the switching process is complex, use of a program timer is most economical. This is purchased from the manufacturer, is installed according to his instructions, and programmed for the local need by the installer. These, in general, are very costly devices, which work extremely well, and need practically no maintenance other than routine cleaning and oiling.

Where the time interval is not always the same, but the switching process is reasonably simple, a variety of adjustable timers is on the market. For short intervals (up to about two minutes), a thyatron timer, similar to the popular "Heathkit" darkroom timer, is usually both satisfactory and inexpensive. Many thyatron timers have been outlined in current available literature. For longer time intervals, clock timers, similar to the "Gra-Lab" timers, are quite satisfactory. These are basically a high-grade electric alarm clock, minus the "time of day" feature.

When the time interval is always the same, simpler devices can be "Goldberged" from standard components, at a considerable saving in parts cost and procurement time. In most industrial electronic work, whatever is needed is needed "yesterday".

Time-limited switches which can be economically made up in the local electronic shop include thermal time-delay devices; and

setups incorporating repeating timers. A working circuit in each category will be outlined with practical constants. Many variations on these circuits are practicable; and cascading a reasonable number of such devices is usually entirely feasible, if the need of the service require it.

## THERMAL TIME DELAY DEVICES

Thermal time delay devices, which form the nucleus of many short time (2-180 seconds) delay and limiting assemblages, consist of a bimetallic strip, which forms the movable arm of a switch, a set of contacts, and a heater. When the heater is cold, the bimetallic strip is in one position; when the heater has been on for a finite time interval, the bimetallic strip warps, and the contact sense is reversed. Most of the heaters are voltage compensated, so that time change due to voltage change is relatively small.

As currently manufactured, thermal time delays are packaged with a glass envelope and a plug-in base, either octal or miniature. They come in a wide variety of voltages, from 2.5 to 115, a range of time delays from 2-180 seconds, and in either normally open or normally closed contacts. Single pole double throw time delays are a special order item.

Contacts in currently manufactured time delays are rated at not more than 3 amperes of non-inductive load at 115 volts AC for the octal-based types, and 2 amperes of non-inductive load at 115 volts AC for the miniature-based types. When these time-delays are used to close lamp or motor loads, contacts must be derated by a considerable factor (six in the case of lamps) so that the inrush currents will not weld them. Very complete instructions and technical data are furnished by some of the manufacturers of these thermal time-delays (Amperite, for example).

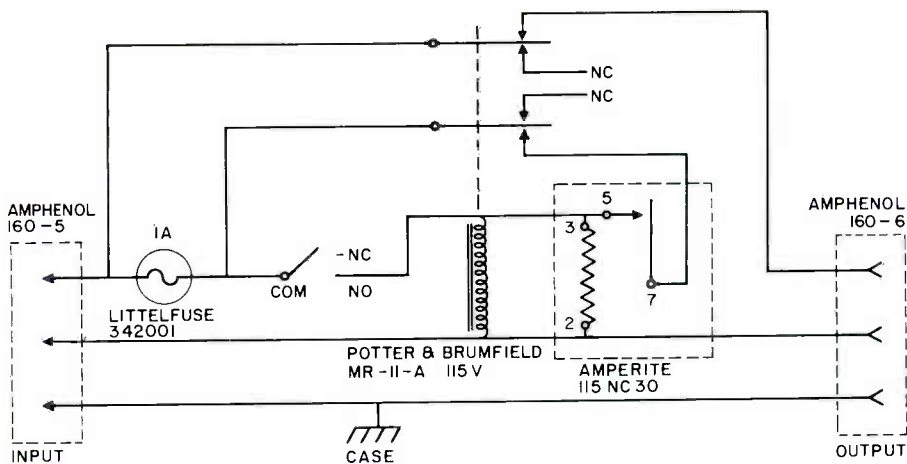

FIG. 1. Complete circuit of 30-second time-limited switch using thermal delay element.

In use, except for very small currents, thermal time delays are employed in conjunction with a relay, usually wired as a self-holder. Complete circuit of a time-limited switch employing a thermal time delay and a relay is shown in Fig. 1, with working constants. As shown, the device disconnects the load from the line for thirty seconds after the button is pushed, then reconnects the load. This specific device was developed to shut off the fume sucker of a reproducing machine while the paper was being changed.

With line and load connected, the load is energized through the upper contacts of the relay, and the thermal time delay heater is cold. As this is an NC (normally-closed) type, the contacts are closed. When the push button is depressed, the relay is energized from the line, the armature pulls down. This shorts the push button, through the lower relay contacts and the time delay contacts, so that the relay stays energized when the push button is released. At the same time, the time delay heater, in shunt with the relay coil, is energized, and the load is disconnected from the line by the upper relay contacts.

This condition prevails for the duration of the built-in time delay (here 30 seconds). At the end of this period, the contacts in the thermal time delay open, removing current from the relay coil and time-delay heater. This releases the relay armature, which rises and reconnects the load to the line. After a reasonable cooling-off period (about one minute), the switch is ready for another operation.

Construction of a time-limited switch incorporating a thermal time delay element is quite simple and straightforward, although some care is desirable in complying with

municipal and plant electrical codes and rules. Under ordinary conditions, such a switch can be constructed in a 4" by 6" by 2" utility case (an LMB type 141, cut down), with ample room for all components. Panel view is shown in Fig. 2. The input and output connectors are mounted at the rear, so that the cords won't get in the way of the operator's hands. The fuse is mounted between them. This protects only the branch circuit supplying the relay and time delay, and is called for by local rules. Push button is mounted at front center, for ready accessibility.



FIG. 2. Panel view of time-limited switch incorporating thermal time delay.

## CLOCK-CONTROLLED TIME DELAY DEVICES

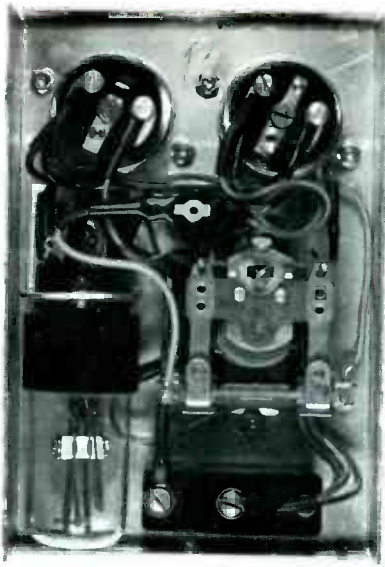

FIG. 3. Interior of thermal time-limited unit.

There is just enough room in the interior of the case for the relay and the time delay element side by side, in front of the input and output connectors. The thermal time delay socket is mounted on a small aluminum bracket, high enough so that the time delay element can be readily unplugged for testing or replacement, if necessary. View of the interior of the switch is shown in Fig. 3. Interior wiring is slightly heavier than necessary, so that the leads are a bit stiff. This prevents them from flopping over into the relay, or otherwise creeping into places where they shouldn't be. As all components are mounted on the case cover, the device can be inspected and serviced readily, with a minimum of disassembly.

Labels in Fig. 2 are Metalphoto, made and applied by the Kohler techniques<sup>1</sup>. A stock of labels is kept on hand to prevent delays in finishing "hurry up" jobs.

Time interval of this switch can be changed by simply changing the thermal time delay unit, which is a plug-in component. If an ON function is needed, instead of the OFF function supplied, this can be obtained by reversing the sense of the upper relay contacts, and changing the push button label from STOP to START.

Construction time for this time-limited switch was 2-1/2 hours from start work to test in place.

(1) Kohler, G. M. "Photography Makes Custom Labels", *Electronics*, Vol. 33, No. 1, Jan. 1, 1960, 100 et seq.

When the time delay required exceeds that normally provided by thermal units, or where considerable precision in the timing is needed, time-limited switches incorporating repeating timers are the preferred type. These are slightly more complex, circuitwise, than those using thermal delays, and their cost is somewhat higher, but construction is not difficult, and maintenance needs are small.

Repeating timers are electric clock motors, usually operated from 115 volts, 60 cycles, with an internal gear train, which drives an external cam and microswitch. As normally supplied, the repeating timer will operate the microswitch once per revolution of the external cam.

Repeating timers are provided in a wide variety of intervals, from one revolution per second to one per week. Longer periods are available on special order. When the time interval desired is an odd multiple of that provided by a standard repeating timer, some manufacturers provide special gear trains so that almost any conceivable repeat rate can be obtained, although not always simply or cheaply.

Time limited switching devices incorporating repeating timers have some special problems, as the clock-controlled microswitch arm is normally in the same position at the start and at the end of the timing cycle. This problem is customarily solved by use of a small auxiliary relay.

Complete circuit of a time-limited switch incorporating a repeating timer is shown in Fig. 4. This specific switch was made to operate the purging fan on a chemical processing chamber for exactly ten minutes after the actuating button was pressed.

Major components here consist of the 6RPH repeating timer, a symmetrical latching relay, and a single pole double throw auxiliary relay, all designed for 115-volt AC operation. Three-wire industrial circuitry is used throughout (the third wire is grounded), and a local fuse is provided to protect the control elements only.

Starting from an initial OFF position, in which the clock motor of the repeating timer is not running, the auxiliary relay armature is up, and the left armature of the latching relay is up, and locked in place by the right armature, which is down, the control push button is pressed. This energizes the left coil of the latching relay, so that the left armature pulls down. The right armature, which is now free to rise, does so, and locks the right armature



in down position. When the left armature rises, its lower contacts open the return of the right coil, so that no more current is drawn by the latching relay, no matter how long the push button remains closed. This is the well-known "self-limiting connection."

The upper contacts of the right coil of the latching relay energize the clock motor, starting the timing process simultaneously with the release of the armature.

Closure of the push button circuit also energizes the coil of the auxiliary relay, pulling down the armature. This connects the relay coil to the line through the microswitch contacts of the repeating timer, so that the relay remains energized after the push button is released.

At an early stage in the timing cycle, rotation of the timer cam opens the microswitch contacts. This deenergizes the auxiliary relay, so that its armature rises, and the high side of the line, through the microswitch on the repeating timer, is now connected to the right coil of the latching relay.

When the timing cycle is complete (when the cam has made one complete revolution) the microswitch again closes. At this instant, the

right hand coil of the latching relay is energized, and its armature pulls down. This disconnects the clock motor from the high side of the line, stopping the timing, and releases the left hand armature so that the return of the left hand coil is opened. In consequence, that coil draws no more current until the push button is again closed.

The external load, plugged into the output, is energized only when the left hand armature of the latching relay is down; or, from the time that the push button is closed until the end of the timing cycle.

Two pilot lamps are provided for operating convenience. The first "Power Pilot" is lighted whenever there is power available at the push button. If the device is either unplugged or has a blown fuse, this lamp will be out. The second "Operating Pilot" is connected across the load, and only lights when the external load is capable of operating. The .1uf capacitors connected across each relay coil are spark absorbers, which not only protect the relay and other contacts against flybacks when the various circuits are opened, but also reduce radio interference from the equipment by a very appreciable factor. With some makes of repeating timers, it is desirable to shunt the clock motor with

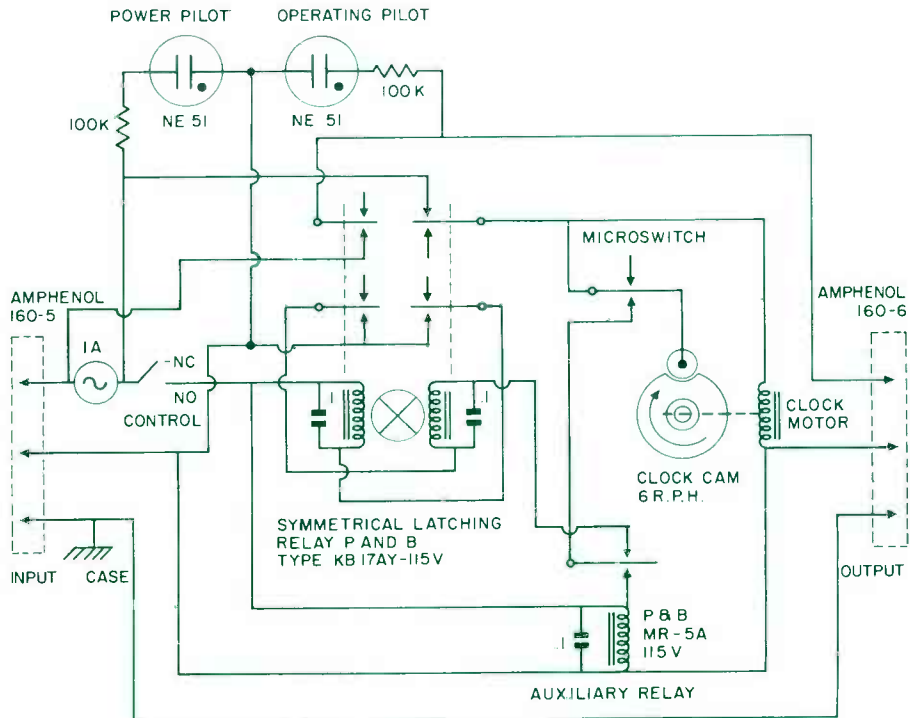

FIG. 4. Circuit of time-limited switch incorporating a repeating timer.

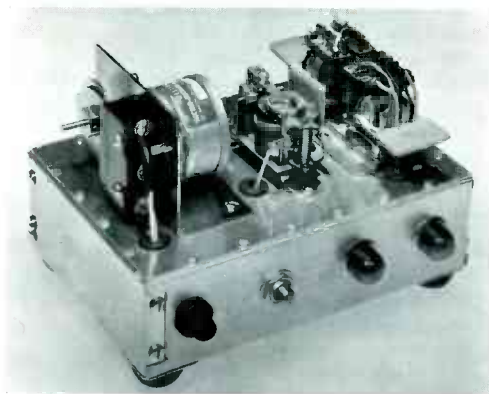

FIG. 5. Above-chassis view of repeating-timer-controlled time limited switch.

a capacitor, such as .5 $\mu$ f. (600 volts). With others, a shunt capacitor has little effect.

Construction of a repeating timer controlled time limited switch is fairly simple and straightforward, requiring only ordinary skill and care. The timer described here was constructed on a 5" by 7" by 2" aluminum chassis with power connections at the rear, and controls and indicators at the front. Appearance of the chassis is shown in Fig. 5. This particular format was selected because it fits conveniently into a 5" by 6" by 9" utility cabinet, which is an "approved" housing under local rules. Controls and indicators are mounted through the front panel of the cabinet, while power plugs are inserted through clearance holes in the rear panel.

Parts layout here is somewhat important. Repeating timer is mounted at the end of the chassis, so that, when the panel is attached, the clock cam and microswitch are still easily accessible for inspection and possible main-

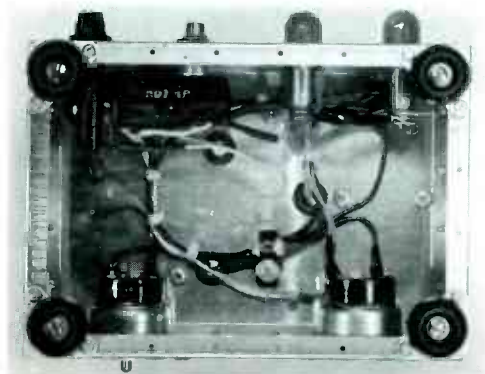

FIG. 6. Under-chassis view of time limited switch incorporating a repeating timer.

tenance. The symmetrical latching relay is mounted at the other end of the chassis, permitting easy inspection of its mechanism, should need arise. The simplest component, the auxiliary relay, is mounted between them with the contacts toward the rear, to facilitate the little inspection and/or servicing that they may need.

All wires through the chassis are passed through grommets holes, to reduce or eliminate wire chafing, with eventual resultant short circuits. Spark-absorbing capacitors (.1 $\mu$ f-500-volt ceramic plates) are mounted directly on the relay coil terminals, to keep the lengths of possibly radiating leads short.

Although the circuit is relatively simple and straightforward, all leads are color-coded, to facilitate circuit tracing, and the "hot" side of the line is carried through from input to output plugs in compliance with local codes, as is the "cold" (unswitched) side of the line.

Multiple junctions of the cold side of the line are made at the tie point under the chassis (Fig. 6), and all wires are cabled by use of Panduit cable ties. This prevents the leads from flopping around inside the chassis. Construction time for the chassis assembly only of this switch was three hours from "parts on hand" to "checkout". Under-chassis view of this switch is shown in Fig. 6.

#### MAINTENANCE AND SERVICE LIFE

Time-limited switches of the designs here presented are essentially long-life devices, capable of operating for thousands of hours with little or no maintenance, provided the relay contacts are not overloaded, or the device is not drastically overvolted. Life of a thermal time delay device is somewhat over 250,000 operations. The relays used seem to be good for more than 10,000,000 operations at reasonable speeds (as used here). Program timers are so nearly "immortal" that equipment incorporating them is likely to become obsolete before the timer wears out. Four and five years of continuous operation with no maintenance needs is not unusual for them.

To get maximum equipment life, relay contacts should be cleaned at regular intervals, such as every 60-90 days. Usually wiping with clean lintless blotter (photographic blotter) is all that will be either necessary or desirable. If the contacts show pitting or blackening, the circuit is either carrying too much current, or is producing flybacks. The first difficulty is corrected by use of larger contacts (or a "backup" relay); the second by installing effective spark absorbers.

# DEVICE OF THE MONTH

## Solar Cells

BY R. C. APPERSON, JR.

Sunlight is energy. This statement leads us into a discussion about two of the most interesting and useful semiconductor devices you're apt to run across in your electronics career. These devices are really a type of converter, since they convert the solar energy in the sun's rays into usable electrical energy. We say sunlight, but they will act on artificial light as well, since it has a similar energy content. The components we will discuss are the solar cell and the photo cell. They both have performed many useful tasks for humanity since their birth.

The photocell was first used primarily as a light measuring device. Photographers have light meters which respond to a similar light spectrum as that the human eye sees. Therefore, the meter is calibrated in a manner as to allow shutter speeds to be ascertained for varying degrees of illumination in order that



A Hoffman battery operated portable transistorized AM receiver with a solar power pack.



The solar pack is made up of a group of solar cells. These cells are mounted on a flat plastic strip.

the proper light will be let into the camera for picture making.

After its use in photography, the photocell was used in another function which has served you on countless occasions. Door openers for stores used the photocell before the mat type opener came into popular use. Stores also relied on the cell for burglar protection, using a series of mirrors, a light source and a photocell as the sensing device.

Photocells have dimmed lights on automobiles, counted pieces on assembly lines, sensed imperfections in products being manufactured, controlled lighting in rooms and served a number of useful operations for mankind.

We are always in quest of greater efficiency, so the solar cell was born. The space program uses the solar cell extensively as a recharging device for the batteries used in

satellites. When the satellite is on the sunlit portion of its journey around the earth, the solar cell gathers solar energy, converts it into electric current and recharges the batteries, much in the way the auto generator does for you in your car everyday. The solar cell does not have the same spectral response as the photocell, so the work load is slightly different. They are used in applications where transfer efficiency and power are of utmost importance.

Now let us investigate the cells and compare the two types of photovoltaic material used. The photocell is made of selenium whereas the solar cell employs silicon. Although silicon is abundant on earth, the process used to manufacture the silicon solar cell requires such highly developed technology and specialized equipment that the cost is greater than that of its cousin, the selenium cell. Both types are packaged in various shapes and sizes and are best identified by their code number and the use of a solar cell and photocell handbook.

Silicon cells can deliver more power from sunlight since they not only act on the visible spectrum of light, they convert some of the invisible spectrum also, whereas selenium "sees" as we do, as we mentioned previously.

How do they convert solar energy into electric current? We know that electrons exist in conductive materials and when they are forced into motion we have current flow. This is the case within the cell. The electrons exist in a fixed condition within the cell and do not move until an outsider enters and collides with them, shaking them into motion. This outsider is the photon, or photo electron, and if it is of the proper wavelength, it will impart sufficient energy to the electron which it strikes to cause current conduction. The more intense the source light, the more energy converted, therefore more output is available from the cell, until maximum output is reached, as shown by the graph. This curve is for a given load and a certain surface area. Since both affect the load current, this is only a representative plot.

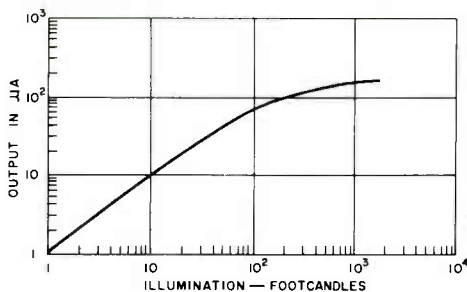

The construction of the cell makes it a semiconductor, therefore the electron will always move in the same direction. This means that, like a battery, the photo and solar cells have polarity and are schematically depicted as this:

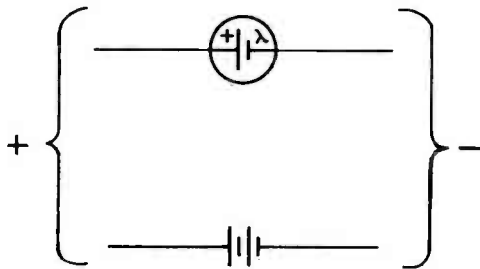

(as compared with the battery). The symbol at the short plate will be recognized as the Greek letter, lambda, the wavelength symbol, and denotes the plate upon which the light impinges.

Like any semiconductor, the cell has other properties which should be recognized. There is, as we mentioned earlier, diode action. The cell also has both shunt capacity and resistance plus an internal series resistance. These effects can be represented by an equivalent circuit, like this:

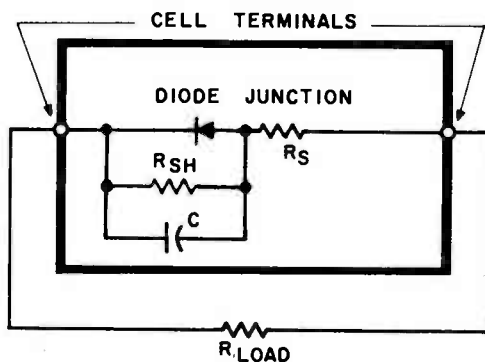

The two major effects are the shunt resistance and shunt capacity, since the resistance affects maximum power transfer and the capacity dictates the frequency response. Frequency response comes into play when the source light is modulated, or flickering, and the cell is being used to detect this modulation. The shunt resistance determines the load resistance.

You may find cells operating singularly, or in either series or parallel configurations. A parallel connection increases the current



in a direct relationship to the number of cells in the circuit. The source resistance is lowered, so you can expect the load to be of lower resistance for maximum power transfer. Since  $R_{\text{source}}$  must equal  $R_{\text{load}}$  for maximum power transfer, cells are also connected in series when the load resistance is high, such as in vacuum tube amplifier circuits. In a series connection, if a malfunction occurs, the first thing to check is the illumination to all cells. If one cell is not illuminated, this essentially places a high resistance in the circuit and all of the voltage is dropped across this cell's resistance.

If you happen to come across a circuit where cells are opposing each other, don't become alarmed, since certain circuits use this type of connection for desired effects. An example of this exists in the series aiding densitometer shown here.

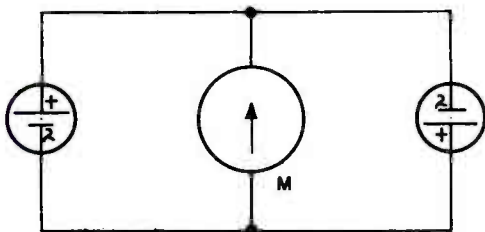

It is used for making density or color content measurements in material or chemical solutions.

A light is projected through the solution and if it impinges equally upon the photocells, the microammeter registers zero. If a dense area appears in front of the cells the meter will deflect and read in terms of density, the meter's scale calibration. The advantage of this type of connection is that the scale of the meter can be expanded simply by increasing the light source intensity, since zero is maintained by an opposition of the two cell outputs.

If a photo or solar cell is thought to be defective, a good test is to connect an ammeter of proper sensitivity for the full illumination current that is listed in the cell handbook and simply stroll outside into the bright sunlight. The meter will deflect into the region of full current capacity if the cell is good.

If the cell is to be checked at night or on a cloudy day, a 150-watt reflector-type flood lamp placed one foot from the cell will substitute adequately for the sun. Care should be taken to maintain the one foot distance, though, since the heat will damage the cell very quickly.

## CIRCUIT OF THE MONTH

This basic introduction to the photocell and the solar cell was intended to interest the technician enough to make him want to experiment with the cell and learn more about it. This leads us to the "circuit of the month," which is simple but very useful when needed.

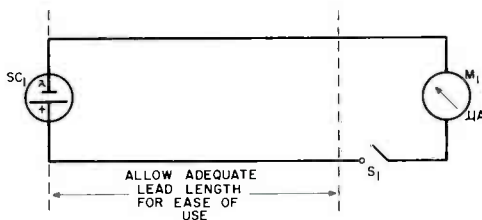

### THE RASTER DETECTOR

#### PARTS LIST

- |    |  |
|----|--|
| S1 | - S1M Solar Cell. International Rectifier, available from Allied Radio with experiment book. |
| M1 | 0-50 Microammeter.   |
| S1 | - SPST Switch.   |

The circuit is what we call a "raster detector". It is a simple light meter but serves the unique purpose of indicating raster on a television CRT when the ion trap is being adjusted. If you have ever changed a picture tube, you will appreciate the value of this device, since it eliminates all of the neck craning connected with trap adjustment. You simply connect the cell to the face of the tube by use of some suction device and place the meter where you can see it while positioning the trap. Be sure the brightness control is in the maximum brightness position. You can actually peak the raster by finding the optimum position for the ion trap.

The circuit operation is self explanatory, simply consider the solar cell as a battery whose current output is dependent upon the light produced by the picture tube.

Since the circuit of the month may only appeal to our TV technician friends, the solar cell in the parts list was chosen with a dual purpose in mind. Included with the cell specified is a very interesting little booklet of thirteen experiments and simple projects, such as a solar powered broadcast receiver, citizen band transmitter and relay circuits plus transistor amplifiers used to increase the sensitivity of the solar cell. It is well written and very informative. Remember, learning is by doing!

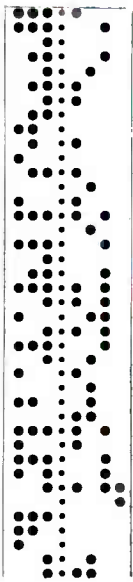

# AUTOMATION

# BY

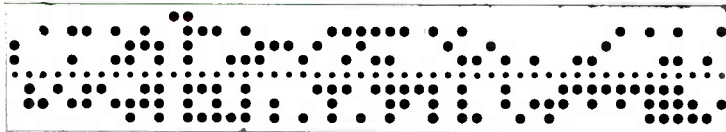

# PUNCHED TAPE

BASIC THEORY OF A WIDELY-USED INDUSTRIAL TECHNIQUE

BY WALLACE B. CHANDLER

A young man, neatly dressed and carrying what appears to be a reel of movie film, enters a large machine shop. He sits down in front of a console, places the tape on a spindle, threads it through a block-looking affair and inserts the other end in another reel. He leans forward and presses a button. The tape advances and, as it does, the entire shop comes to life. Motors start to whine and a product starts through the many processes required before the raw material can be marketed as a machined piece. No drill press operators, no one at the lathe, the only people required are those who perform tasks such as removing a piece from the lathe and placing it on the drill line.

In another part of the country, an electronics technician has a similar reel of tape and goes through similar actions. The end result of his tape threading and button pushing is a completely automatic checkout of a complex piece of radar gear. A machine runs tests on the gear, determines if the gear is working properly and, if it isn't, isolates the malfunction. This is automation. How does it work? Let us discuss just one facet of electronic programming for automation: the use of punched tapes.

## THE PUNCHED TAPE

Although machines are doing many intricate tasks for us today, they are very ignorant devices. Every operation performed must be outlined in detail by a human being and fed to the machine. Many methods are used; here we will discuss the punched tape method in its simplest form. Remember, there are many

forms of programming and many forms of programming by punched tape. The method covered here will be the most basic so that the operation can be followed easily.

The tape upon which instructions are punched can be paper but is usually a Mylar composition so that it will last for many operations. It is about an inch wide and very thin, about the thickness of this printed page. The information is placed on the tape by a perforator machine. The perforator places small, round holes in the tape about the size of a pencil lead. The placement of the hole on the tape is the key to the method. It is punched on the tape by a trained programmer. Fig. 1 shows a section of tape with a few holes punched in it. The arrow shows the direction in which the tape will move through the reader. The reader is the device on the console upon which our operator placed his reel on tape; we will elaborate on it later. Note the dotted lines on the tape. These are just to aid our discussion.

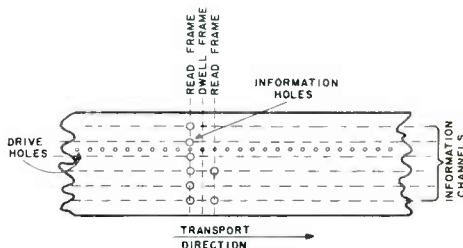

FIG. 1. Punched tape showing frames, sprocket holes and information channels.

There are eight precise horizontal lines on the tape. These we will call information channels. Punched holes will fall on one of these lines, giving us a specific number of information channels which can be used. Notice a vertical line with eight punched holes. This is a frame and will be read simultaneously by the reader. Next we have a blank space, then two holes. The blank space is a dwell frame; holes represent what we will refer to as a read frame. The series of small holes running vertically are sprocket holes, used to feed the tape through the reader. Now we will take a brief look at the reading mechanism.

### THE READER

Only the function of the reader will be dealt with here, since this is a very complex mechanism and could only be treated properly in a full length discussion.

A sketch of a typical reader appears in Fig. 2. The reader head is the heart of this device. In it are tiny, spring loaded fingers the size of the perforated holes in the tape. The fingers control sensitive switches which, in turn, control voltages. We will use 28 VDC as an example. Examining Fig. 2 we see the two reels, one a take-up type, one a feed or supply reel.

The tape may be moved in either direction, at a faster rate than when the reader is in the read mode; this is the slew mode. Circuitry associated with the reader disconnects the fingers while the tape is being transported in the slew mode. What does the 28 VDC at the fingers control when a hole allows the finger to open a switch? Let's see.

### THE PROGRAMMED PATH

The motors which operate the equipment must be told when to start and when to stop. This can be done with a switch, but this is not automatic. We will use relays, ones in which the contacts make before they break from their original position. This is important. Since many motors are involved, many controlling relays will be needed. The reader will furnish 28 VDC to the relays, but we will need a unique method of telling the proper relay when to be energized. The relay must be identified and have separate identity from all other relays being used. Since we have eight holes, we could energize eight relays independently. We can see easily that if eight operations were all that we were interested in, this whole idea would be too expensive to make it practical. Let's surmise that we have to control fifty-six relays. What will we need to identify each relay?

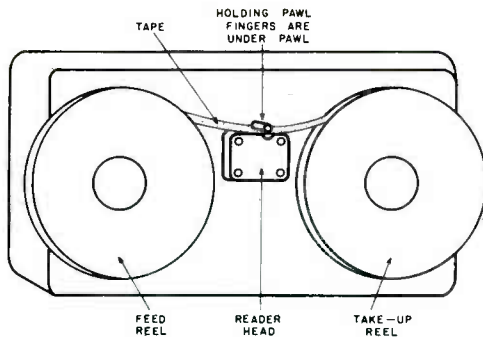

FIG. 2. Sketch of reader showing reels, reader head with tape threaded, and holding pawl. Motors and other circuitry are not shown but are housed behind reader.

### IDENTIFICATION

To identify each relay, we will give it a name and address, much like ours. The name of some relays may be the same, but each one with the same name will have a different address. We will refer to the relay names as commands and to the addresses as simply, address.

We have eight holes on the tape and eight fingers, therefore you would think immediately that eight commands will be used. This is not so. We'll use seven, since we have to use the eighth hole to identify a command from an address. Commands will be noted as A through G.

Since we have fifty-six relays to be energized at random, we will need eight addresses, in order that each relay has a separate identity. Counting the holes, we find only seven usable holes. Fig. 3 shows the solution to this problem. It is what we refer to as a relay tree, since it is shaped like a tree schematically.

We will apply a ground to a relay we wish to address and the command will be the 28 VDC available through the reader contacts. This same 28 VDC is used to energize the tree. A look at its operation is imperative.

### THE ADDRESS TREE

Before we investigate the tree, let's examine circuitry for an important part of the tree. The relay, Fig. 4 shows a relay wired in a self-latching configuration. The voltage is applied through one contact to the coil. The relay energizes and holds in on an equal voltage which is applied to the other contact. If we want to add more contacts, another relay or relays may be connected across the coil of the self-latched one and form what is known as a slaved operation, shown by dotted lines in Fig. 4.

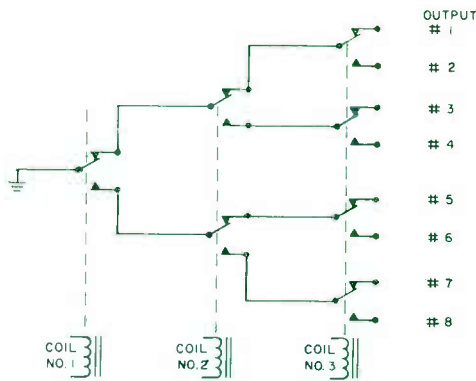

FIG. 3. This is a relay tree. Output No. 1 appears with no relays energized. Combinations of the three relays, when energized, give outputs 2 through 8.

The tree is made up of many slaved relays. We start with one set of contacts and we have ground available at two contacts (see Fig. 3). By adding another latched relay we can route the ground to not two, but to four places. Each bank doubles the last bank. In Fig. 3, we show eight possible contacts for ground to appear on; these will be our eight addresses.

When the proper hole appears on the tape, the relay or relays necessary in the tree are energized and ground appears at the desired contact. As many as are needed may be added, within reason.

Also incorporated in the tree circuitry is a transfer relay, which, with the help of internally generated signals from the reader and those appearing due to the punched tape determines whether we shall route out an address or command. The last hole on the tape can be used for this. If it is present, the transfer relay energizes and allows the next voltage from the finger contacts to be applied to set up the tree. Likewise, if no eighth hole is present, the transfer stays in a state of rest and the command voltage is routed out.

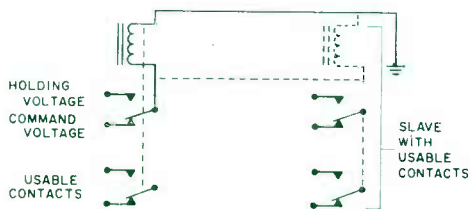

FIG. 4. A relay with its slave (dotted lines) showing how it is wired in the self-latching configuration.

It should be noted here that the voltage is present for only the duration of time that the perforated tape is over a finger. A pulse is generated, width determined by the travel time of the tape. This pulse energizes the relays and they are held in by a fixed voltage as we showed earlier.

Now that we have set up the tree, we must decide upon a method of de-energizing the relays. We will refer to this operation as drop out.

One of the signals coming from the reader is a ground of short duration that occurs at a fixed rate. Whenever the transfer relay is not energized, this ground is routed to the "hold in" contact of the tree relays. A resistor (Fig. 5) is in series with the relays and the 28-volt supply, so that for the instant the ground is applied, the voltage is dropped across this resistor and the tree clears. We

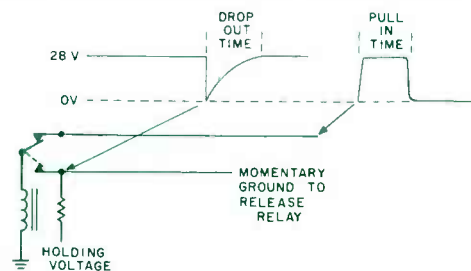

FIG. 5. A self-latching relay showing dropping resistor. Waveforms show voltage at coil as momentary ground is applied and short pulse which energizes relay.

will use this method later to release relays in the control group.

### THE CONTROL GROUP - PROGRAMMED RELAYS

These are the relays that do the work, applying the power to the motors and releasing them at the proper instant. Fig. 6 shows the signals needed to identify each relay. We will note that the relays are not only self-latching voltagewise, but that ground is also switched. This switching of ground is the addressing function. The switched voltage is the command. The presence of both signals is necessary to energize a relay. A point of interest is that when a command is applied, it appears at all relays having the same "name". The address will be applied to only one particular relay. This one will energize. Each relay will have a resistor in series with the "hold in" voltage. This is the resistor which drops the voltage when the drop out signal is applied.

Drop out in the control group is performed by



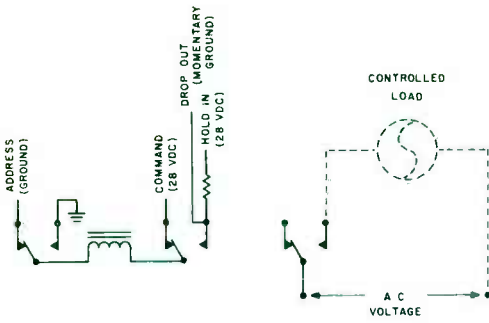

FIG. 6. A controlling relay with all signals needed to identify it from other relays.

relays in the circuitry associated with the tree which energize for only an instant, and during this short interval, connect the ground from the tree to the relay to be de-energized. We simply punch the tape so that a command follows the address and we address the relay which we wish to drop out. The address appears as usual at the relay, but we also apply it to the coil and no command is applied, therefore the relay de-energizes.

The tape can be used to energize and de-energize these relays at will. It can also determine how long each one stays energized, according to the duration between "address

with command" and "address with no command", or drop out condition.

### SUMMARY

We have only touched on the highlights of this subject. Many complex arrangements are devised every day using the basic components we have discussed.

If many relays are to be energized, paths can be set up by using more than one command to get the end result. The logic is expressed in binary notation and the holes on the tape are identified by this notation, instead of the simple A through G as we used.

It was the intention of the author to demonstrate the use of punched tape and relays to perform work so that the technician will have a better understanding if ever faced with this type of automation.

The principle may change, but one of man's greatest steps toward an easier way of life is automation, so let's not fight it. Some say that this "beast" is knocking many people out of work but, as was stated earlier, someone has to instruct the machinery and keep the "brain" functioning. We in electronics will not suffer, but gain, from automation.

## CONAR ORDER BLANK

DIVISION OF NATIONAL RADIO INSTITUTE, 3939 WISCONSIN AVE., WASHINGTON 16, D.C.

PLEASE PRINT

NAME \_\_\_\_\_

ADDRESS \_\_\_\_\_

CITY \_\_\_\_\_ ZONE \_\_\_\_\_ STATE \_\_\_\_\_

NRI STUDENT NUMBER

CASH  
 C.O.D. (20% Deposit required)  
 EASY PAYMENT PLAN (10% Deposit)

Quantity	Model	Name of Item	Price Each	Total
TOTAL				

If you live in Washington, D.C., add 3% sales tax. All prices are net, F.O.B. Washington, D.C.

**ON TIME PAYMENT ORDERS** please be sure to complete the Easy Payment Plan credit information form on the reverse side of this page and include 10% down payment with your order.

**ON OUR COVER**

Floyd Cox, NRI graduate, sparked what has become an annual drive in Los Angeles that brings Christmas cheer to handicapped and sick children and adults. He calls the drive "Operation Santa Claus."



The idea of the campaign is that every member of the Los Angeles Chapter of the California State Electronics Association donate at least one good reconditioned television set to a worthy institution. The donated sets are delivered to the institutions by Boy and Girl Scouts who play the role of Santa Claus.

This is a truly heart warming activity and one that could easily be adopted in many other communities.

Fred Cox at his shop with some of the Girl Scouts who help in the campaign by acting as "Santa Claus" and delivering the reconditioned sets to the institutions.



# Happy Holidays

*The editors of the Journal join the entire staff of NRI in wishing you a joyous holiday season. May Christmas bring you peace and happiness and may your New Year be prosperous.*

## CONAR EASY PAYMENT PLAN

Note: Easy payment contracts cannot be accepted from persons under 21 years of age. If you are under 21, have this sheet filled in by a person of legal age and regularly employed.

Enclosed is a down payment of \$\_\_\_\_\_ on the equipment I have listed on the reverse side. Beginning 30 days from the date of shipment I will pay you \$\_\_\_\_\_ each month until the total payment price is paid. You will retain title of this equipment until this amount is fully paid. If I do not make the payments as agreed, you may declare the entire unpaid balance immediately due and payable, or at your option, repossess the equipment. Your acceptance of this will be effected by your shipment to me of the equipment I have listed.

Date \_\_\_\_\_ Your written signature \_\_\_\_\_

**CREDIT APPLICATION**

Print Full Name \_\_\_\_\_ Age \_\_\_\_\_  
 Home Address \_\_\_\_\_  
 City & State \_\_\_\_\_ How long at this address? \_\_\_\_\_  
 Previous Address \_\_\_\_\_  
 City & State \_\_\_\_\_ How long at this address? \_\_\_\_\_  
 Present Employer \_\_\_\_\_ Position \_\_\_\_\_ Monthly Income \_\_\_\_\_  
 Business Address \_\_\_\_\_ How Long Employed? \_\_\_\_\_  
 If in business for self, what business? \_\_\_\_\_ How Long? \_\_\_\_\_  
 Bank Account with \_\_\_\_\_ Savings  Checking

**CREDIT REFERENCE** (Give 2 Merchants, Firms or Finance Companies with whom you have or have had accounts.

Credit Acct. with \_\_\_\_\_ (Name) \_\_\_\_\_ (Address) \_\_\_\_\_ Highest Credit \_\_\_\_\_  
 Credit Acct. with \_\_\_\_\_ (Name) \_\_\_\_\_ (Address) \_\_\_\_\_ Highest Credit \_\_\_\_\_

# ALUMNI NEWS



John Berka .....	President
Howard Tate .....	Vice President
James Kelley .....	Vice President
Eugene DeCaussin .....	Vice President
David Spitzer .....	Vice President
Theodore E. Rose .....	Executive Sect.

## J. Arthur Ragsdale New President Of Alumni

It has been noted elsewhere that West Coast folks, particularly Californians, are intensely loyal toward their leaders and "favorite sons." This has been proved once again in the election of J. Arthur Ragsdale of the San Francisco Chapter as President of the NRI Alumni Association for 1964. The vote from the West Coast generally was heavy but especially so from California.

The runner-up, Dave Spitzer of New York, had good support from his area but it simply could not compete with the strength of the vote from the West Coast.

The West Coast and particularly California demonstrated its loyalty in regard to Vice Presidents, too. They returned Eugene DeCaussin to office for a second term.



President-Elect of the NRI Alumni Association for 1964, J. Arthur Ragsdale of San Francisco.

Howard Tate of Pittsburgh was also elected for a second term with the largest number of votes cast for a Vice President. And two old-timers are back on the slate of National Officers: Frank Zimmer of New York City and Jules Cohen of Philadelphia. Both of them are former Presidents and Vice Presidents and both fully deserve this repeated recognition.

J. Arthur Ragsdale was born in San Francisco in 1888. Graduating from high school in 1903, he went to work as an office boy until the big earthquake of 1906, after which he took a job in the office of a lumber company. He studied shorthand and typing at a business college, worked as a typist and bill clerk for various companies until 1921, whereupon he secured an appointment as a general clerk in the City and County of San Francisco. He matriculated at the University of California in 1926 and graduated in 1931 with an A. B. degree in physics.

Art held several jobs with the Municipal Railway and the San Francisco Water Department until 1943, when he accepted an appointment as a physicist in Electronics with the Bureau of Standards in Washington. After the war he returned to the San Francisco Water Department as head clerk in charge of the waterfront office. In 1953 he retired from this position, enrolled for his NRI training and, upon completing it, opened a Radio-TV repair shop in his home. Six years later he organized the San Francisco Chapter, served as Chairman for two years, then as Secretary, and was elected as National Vice President for two terms. At present he is a member of the Program Committee of his chapter.

Art takes an occasional vacation from his Radio-TV work so he and his wife Shelba can enjoy their chief recreation, traveling and sightseeing. Art's other hobby is reading.

President-Elect Ragsdale will take over his office January 1, the day after John Berka ends his term as President.

Our warmest congratulations to the new officers!

## Visits To The Local Alumni Chapters

Last year J. B. Straughn Chief of NRI Consultation Service, accompanied Executive Secretary Ted Rose on his annual visit to the various local chapters. Mr. Straughn's lectures and demonstrations on Radio-TV- Electronics were so enthusiastically received that he is repeating them this season. Below is a schedule of the visits yet to be made.

CHAPTER	DATE
New Orleans	January 14
Minneapolis-St. Paul	April 9
Pittsburgh	May 7
Hackensack	May 29

All NRI students and graduates are welcome at the meetings whether they are members or not. Take advantage of this chance to meet Mr. Straughn and to hear him lecture on Electronics. See "Directory of Local Chapters" on page for information on time and place of meetings.

## CHAPTER CHATTER

DETROIT CHAPTER'S Secretary George Povlich demonstrated troubleshooting the tuner and i-f section of a television receiver. In addition to showing how to use a scope, he explained the circuit disturbance test, using a grounded 1600-volt capacitor with test leads.

Leo Blevins was elected by the members to secure films on Electronics to be shown at future chapter meetings.

FLINT (SAGINAW VALLEY) CHAPTER turned its October meeting over to two visitors from Washington, J. B. Straughn, Chief, NRI Consultation Service, and Ted Rose, Executive Secretary of the NRI Alumni Association. After a short address by Ted Rose, Mr. Straughn devoted the remainder of the evening to a lecture and demonstrations in which the members obviously took intense interest. Chairman Jobbagy, on behalf of the chapter presented to each of the visitors a beer and pretzel server as a memento of the occasion.

HACKENSACK CHAPTER Chairman George Schalk recently wrote National Headquarters that since the chapter was formed last May, the members' high interest has continued and that attendance is good. This is what it takes

to build a strong and progressive chapter. More power to the Hackensack Chapter.

The last meeting reported to National Headquarters was devoted almost entirely to troubleshooting two TV receivers brought in by members, beginning at 8 P. M. and continuing until 11 P. M. The troubleshooting was interrupted only briefly for a short business meeting and an interesting talk by Cres Gomez.

LOS ANGELES CHAPTER members have given some consideration to the possibility of making a trip to Pueblo, Colo., and also a trip to San Francisco to visit the chapter there. Perhaps one or both of these journeys will have taken place by the time this issue of the Journal is distributed.

Chairman Gene DeCaussin demonstrated how to use a circuit analyzer to locate trouble in a TV receiver. He also demonstrated his Ansaphone, and automatic device used to take phone messages while he is out of his shop.

Bob Belew displayed his new Conar Multi-Socket Adapter and explained how it modernizes old tube checkers for 12-pin Compactrons, 10-pin miniatures, 5- and 7-pin Nuvisitors, and Novar types.

An interesting incident took place when Bill Edwards made an educated guess on what was the trouble in a TV set that Chairman DeCaussin was working on. Bill came up with the exact cause, despite the fact that tests indicated other reasons for the defect. Bill was then asked to give his opinion concerning two superheterodyne sets which produced only static. He suggested a different reason for each set. The true reason was to be made known to the members when both receivers have been repaired.

At another meeting Chairman DeCaussin read an article about local bait and exchange dealers who advertise something as a come-on but don't actually have it to sell. An 18-minute film on this subject was ordered to be shown at a later meeting. Bill Edwards displayed an interesting oddity -- a phonograph made about 1920 which folded up into a 4" x 6" x 6" box.

All NRI men in the area, please note: The chapter now holds its meetings at Chairman Gene DeCaussin's new Radio-TV Shop, 4912 Fountain Ave., Los Angeles.

MINNEAPOLIS-ST. PAUL (TWIN CITY) CHAPTER is working on a breadboard transistor radio. This project is expected to take





NRIAA Executive Secretary Ted Rose and J. B. Straughn toasting each other with steins presented to them at the Saginaw Chapter's October meeting. (There's nothing in the steins.) At right: Chairman Andrew Jobbagy.

up several meetings. It should provide the members with a good deal of practical, helpful information.

The chapter scheduled its annual banquet for members and their wives for the latter half of October (too late for a report on it to be included in this issue of the Journal). The place picked for the event this year was Jens Embassy Club, one-half mile south of the Minnesota River on Highway 65. This annual event is always an enjoyable occasion for the wives as well as the members.

NEW YORK CITY CHAPTER has been most fortunate in having quite varied programs this fall and in having its own able speaker to conduct them. Frank Zimmer gave a masterful talk on tape recorders, their history, operation, and maintenance. He supplemented this with tape samples, diagrams, a Cook's Tour through a beautiful stereophonic recorder, and a demonstration.

A talk by Pete Carter on problems he has encountered in service work included detailed explanations of the operation of the circuits involved. Jim Eaddy has started a series of lectures based on the transistor sets and clock mechanisms which his employer (Bulova) has been so generous in supplying to the chapter. Chairman Dave Spitzer has talked on relays, their operation and adjustment, with emphasis on those found on oil burners and also automatic garage-door actuators.

The chapter welcomed back to the fold old-timers Cambria and Vargas, also new member Edward Jarl.

PHILADELPHIA-CAMDEN CHAPTER members are naturally overjoyed that their Secretary, up-and-at-'em Jules Cohen, has once

again been elected to national office, this time as Vice-President of the NRI Alumni Association for 1964. They are, of course, in the best position to know how unstinting of his time and energy Jules has been in behalf of his fellow members and how deserving he is of all honors bestowed upon him.

Mention was made in the last two issues of the NRI Journal that Jules had been trying to arrange with the Philco Corp. for a tour of one of their plants. This was postponed but he finally succeeded in arranging a tour of the Philadelphia Police Communications, which was to take place last month. In addition he has gone ahead with still another tour, this one of the Westinghouse plant of Metuchen, N. J.

These tours are always fascinating. Any NRI men in the area interested in going on one or more of them should contact Secretary Jules Cohen or Chairman John Pirrung.

The most recent new members admitted to membership are John J. Warton, Phila., and Daniel Kelly, Bridgeton, N. J.

SAN ANTONIO (ALAMO) CHAPTER'S latest meeting of which we have a report was not a regular meeting but was turned into "servicing night". The members brought in radio receivers that were repaired at the meeting. Techniques in repairing auto receivers by use of the scope, and other radio repair problems, were discussed at length.

SAN FRANCISCO CHAPTER members were given a number of valuable service hints on the care and precaution that should be exercised when connecting up motors for operation. At the same meeting Chairman Pete Salvotti took the lead in discussing the new NRI Journal and expressing enthusiastic approval of it. Thanks for the bouquets, fellows.

John Cullen made arrangements with a representative of the United Airlines for the chapter members to make a tour of the United's shops in November.

SOUTHEASTERN MASSACHUSETTS CHAPTER, like the Saginaw Chapter, turned its first meeting of the winter season over to J. B. Straughn and Ted Rose when they visited the chapter this fall. After the lecture and demonstrations by Mr. Straughn and a question-and-answer period which followed, the members and guests enjoyed the refreshments provided by the chapter.

SPRINGFIELD (MASS.) CHAPTER featured a demonstration by Treasurer Gus Lorenzatti at its first meeting of the season. Gus demon-

strated a resistance and capacitor substitution box he had built.

Plans were completed to hold a dinner at Oaks Inn, Springfield, on November 20.

---

### Directory of Local Chapters

*Local chapters of the NRI Alumni Association cordially welcome visits from all NRI students and graduates as guests or prospective members. For more information contact the Chairman of the chapter you would like to visit or consider joining.*

CHICAGO CHAPTER meets 8:00 P. M., 2nd and 4th Wednesday of each month, 666 Lake Shore Dr., West Entrance, 33rd Floor, Chicago. Chairman: Frank Dominski, 2646 W. Potomac, Chicago, Ill.

DETROIT CHAPTER meets 8:00 P. M., 2nd and 4th Friday of each month, St. Andrews Hall, 431 E. Congress St., Detroit. Chairman: James Kelley, 1140 Livernois, Detroit, Mich., VI-1-4972.

FLINT (SAGINAW VALLEY) CHAPTER meets 8:00 P. M., 2nd Wednesday of each month at Chairman Andrew Jobbagy's Shop G-5507 S. Saginaw Rd., Flint Mich. OW 46773.

HACKENSACK CHAPTER meets 8:00 P. M., last Friday of each month, Hackensack YMCA, 360 Main St., Hackensack, N. J. Chairman: George Schalk, 471 Saddle River Rd., Ridgewood, N. J.

HAGERSTOWN (CUMBERLAND VALLEY) CHAPTER meets 7:30 P. M., 2nd Thursday of each month at the YMCA in Hagerstown, Md. Chairman: Francis Lyons, 2239 Beverly Dr., Hagerstown, Md. Reg 9-8280.

LOS ANGELES CHAPTER meets 8:00 P. M., 2nd and last Saturday of each month, 4912 Fountain Ave., L.A. Chairman: Eugene DeCaussin, 5870 Franklin Ave., Apt. 203, Hollywood, Calif., HO 5-2356.

MINNEAPOLIS-ST. PAUL (TWIN CITIES) CHAPTER meets 8:00 P. M., 2nd Thursday of each month, Walt Berbee's Radio-TV Shop 915 St. Clair St., St. Paul. Chairman: Paul Donatell, 1645 Sherwood Ave., St. Paul, Minn., PR 4-6495.

NEW ORLEANS CHAPTER meets 8:00 P. M., 2nd Tuesday of each month at Galjour's TV, 809 N. Broad St., New Orleans, La. Chairman: Herman Blackford, 5301 Tchoupitoulas St., New Orleans, La.

NEW YORK CITY CHAPTER meets 8:30 P. M., 1st and 3rd Thursday of each month, St. Marks Community Center, 12 St. Marks

Pl., New York City. Chairman: David Spitzer, 2052 81st St., Brooklyn, N. Y., CL 6-6564.

PHILADELPHIA-CAMDEN CHAPTER meets 8:00 P. M., 2nd and 4th Monday of each month, K of C Hall, Tulip and Tyson Sts., Philadelphia. Chairman: John Pirrung, 2923 Longshore Ave., Philadelphia, Pa.

PITTSBURGH CHAPTER meets 8:00 P. M., 1st Thursday of each month, 436 Forbes Ave., Pittsburgh. Chairman: Thomas Schnader, RD 3, Irwin, Pa., 731-8327.

SAN ANTONIO ALAMO CHAPTER meets 7:30 P. M., 3rd Wednesday of each month, Beethoven Hall, 422 Pereida, San Antonio. Chairman: Jesse De Lao, 606 Knotty Knott, San Antonio, Texas.

SAN FRANCISCO CHAPTER meets 8:00 P.M., 1st Wednesday of each month, 147 Albion St., San Francisco. Chairman: Peter Salvotti, 2543 Great Hwy., San Francisco, Calif.

SOUTHEASTERN MASSACHUSETTS CHAPTER meets 8:00 P. M., last Wednesday of each month, home of John Alves, 57 Allen Blvd., Swansea, Mass. Chairman: James Donnelly, 30 Lyon St., Fall River, Mass. OS 2-5371.

SPRINGFIELD (MASS.) CHAPTER meets 7:00 P. M., last Saturday of each month at shop of Norman Charest, 74 Redfern St., Springfield, Mass. Chairman Steven Chomyn, Powder Mill Rd., Southwich, Mass.

---

### ANSWER TO LUCKY'S PROBLEM

(What Would You Have Done? - Page 14)

With the record player operating, tone-arm on the 400-cycle record, Lucky took an AC voltage measurement. The instrument was set to the 0-5 volt AC range, test leads connected directly to the lead wires from the pickup. A good crystal will give at least 2.5 to 3 volt reading, depending, of course, on the test record (which can be predetermined on a new unit, beforehand). Ordinary music passages, in case a test record is not available, will show a varying voltage between 1 volt and 6 volts AC on peaks.

Crystals that are in various stages of deterioration will always show a marked decrease in voltage output on a VTVM.

In cases where the voltage output is of questionable clarity or is distorted, the sine wave output of a test record may be studied on an oscilloscope and the distortion level compared with that of a known, good crystal. Voltage output may also be determined on an oscilloscope when the instrument has a calibrated scale on the screen.

Save with these  
**RECOMMENDED**  
**"BEST BUYS"**

"VALUE-RATED" **B&K** INSTRUMENTS FROM

# CONAR



## Check ALL circuits in minutes! **TRANSISTOR RADIO ANALYST**

### **B&K** Model 960

Now you can really profit from transistor radio servicing! This B&K Model 960 gives you everything in one easy-to-use instrument. A complete signal-generating source for point-to-point signal injection using exclusive new "Dyna-Trace" single-point probe. Built-in metered power supply and VTVM. Has "Good-Bad" scale for both leakage and beta, direct-reading beta scale, also determines if transistor is NPN or PNP. Brings you new customers for service, parts, batteries. Get it now!

CONAR  
PRICE:

**\$97<sup>95</sup>**

\$9.80 down,  
\$8.00/mo.

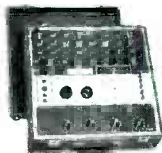

### Model 700 Dyna-Quik Mutual Conductance **TUBE TESTER**

Built for today and tomorrow—obsolescence-proof! Dynamically tests all old and new radio and TV tubes, Nuvistors, Novars, new 10 and 12-pin types, European hi-fi tubes, voltage regs., most industrial types. Checks for all shorts, grid emission, leakage and gas plus quick life test. Will pay for itself quickly.

CONAR  
PRICE: **\$166<sup>55</sup>**

\$16.66, down \$14.00/mo.

grid emission, leakage and gas plus quick life test. Will pay for itself quickly.

### Easy Component Checks with Model 230 **SUBSTITUTION MASTER**



Save time and work, just substitute a known value from the B&K Model 230 for a questionable component. Provides full range of values for resistors, capacitors, electrolytics, selenium and silicon rectifiers. Surge protector. Isolated sections operate separately. Complete with four test leads.

CONAR  
PRICE: **\$44<sup>05</sup>**

\$4.41 down, \$5.00/mo.

## **QUICK, DIRECT, ERROR-FREE READINGS AUTOMATICALLY!**

### **DYNAMATIC 375 VTVM**



Just set range switch, correct scale appears automatically! Only one scale visible at one time. Saves time, avoids calculations, errors. Read p-p voltages of complex wave forms in video, sync, deflection, pulse circuits, radar, etc. DC current ranges, too. (R.F. and High-V Probes

CONAR  
PRICE: **\$88<sup>15</sup>**

\$8.81 down, \$8.00/mo. at extra cost.)

### **VO Matic 360 VOM**



Has same automatic scale features as VTVM. No multiplying, no false readings. Features burn-out proof meter movement. Sensitivity is 20,000 ohms/V, DC; 5,000 ohms/V, AC. Ranges from 0 to 6000 Volts plus supplemental ranges. Complete with batteries and test leads.

CONAR  
PRICE: **\$58<sup>75</sup>**

\$5.88 down, \$6.00/mo.

**USE HANDY ORDER FORM ON PAGE 27—CASH OR TERMS**

# Close-Out SALE

GIVE YOUR NRI VTVM---  
THAT PROFESSIONAL LOOK!

If you haven't put your Model W VTVM in a cabinet yet--now is the time. Available through CONAR--this attractive, durable cabinet will protect and professionalize your VTVM. Installation takes one minute--and a screwdriver! Designed specially for your VTVM to make you proud of performance and appearance. Also serves as a handy cabinet for experimental chassis. Includes chrome handle and screws. Stock # 1CY



Reg. Price \$3.75 (plus postage) Use order blank on page 27.

**Sale Price \$2.25** (postage included)

Mr. Willard F. Velline  
1322 S. 14<sup>th</sup>  
Fargo, N. Dak.

25923-G

**NRI JOURNAL**  
3939 Wisconsin Ave.  
Washington D. C. 20016

Second-class  
postage paid  
at Washington, D. C.