

August/September 1963

35 Cents

journal

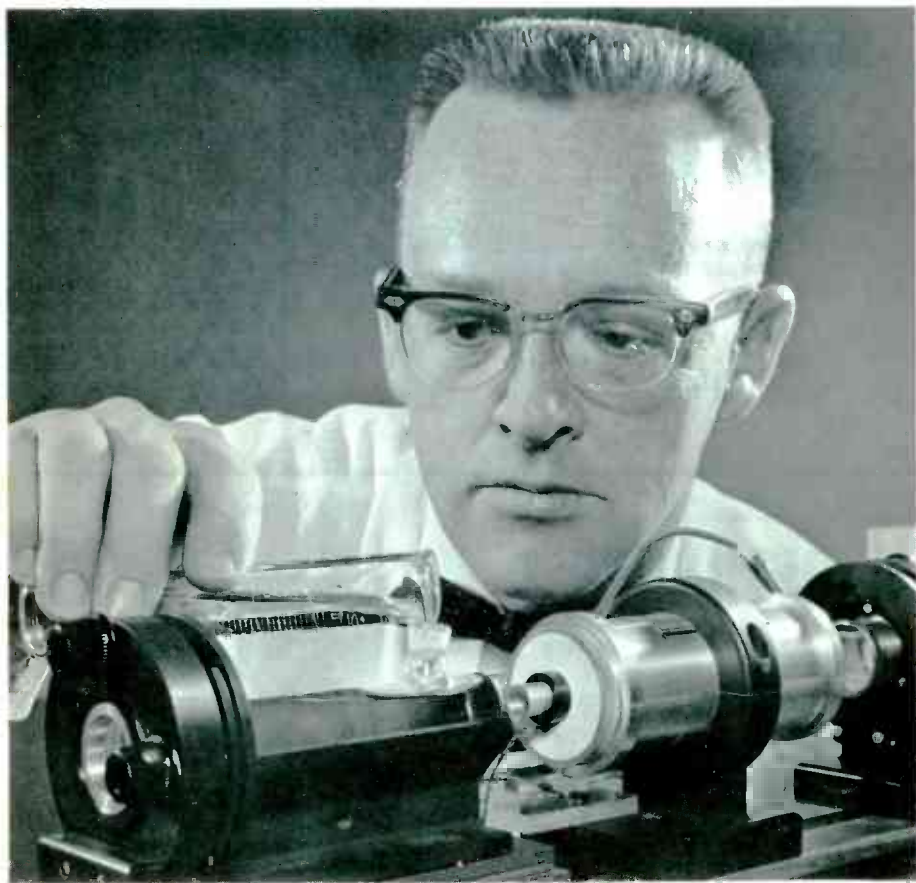

Courtesy Hughes Aircraft Company

In this issue:

**SIDEBAND COMMUNICATIONS
ANTENNAS FOR FM STEREO
A LOOK AT LASERS**



journal

Formerly NRI News

VOL. 20, NO. 10.

AUGUST/SEPTEMBER 1963

Contents

SIDEBAND COMMUNICATIONS

MODERN AM SYSTEMS Page 1

ANTENNAS FOR FM STEREO

OUTDOOR ANTENNAS FOR RADIO Page 6

A LOOK AT LASERS

A LIGHT FOR THE FUTURE Page 10

REDUCING SOLENOID HOLDING CURRENTS

PRACTICAL CIRCUIT IMPROVEMENTS Page 17

A TV REPAIRMAN'S LAMENT

A REBUTTAL Page 20

ALUMNI NEWS

. Page 24

OLIVER READ, W4TWV
Editor and Publisher

ELIZABETH MORALES
Managing Editor

J. B. STRAUGHN
Technical Editor

T. E. ROSE
Editor - Alumni News

Published every other month by
the National Radio Institute
3939 Wisconsin Ave., Wash-
ington 16, D. C. Subscriptions \$2.00
a year. Printed in U. S. A. Sec-
ond class postage paid at
Washington, D. C.

A REMINDER !

BEGINNING NEXT ISSUE

(OCTOBER)

NRI JOURNAL WILL BE PUBLISHED
IN ITS NEW FORMAT IN COLOR AND
ON LARGER PAGE SIZE.

YOU WILL RECEIVE THE JOURNAL
EACH MONTH (12 TIMES A YEAR.)

OUR COVER

Dr. Fred J. McClung of the research laboratories of Hughes Aircraft Company pours nitrobenzine into the glass sample holder of a new "liquid laser" developed by that company.

MR. ZIP

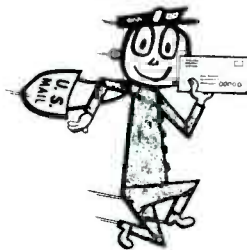

Remember to include your ZIP Code number in all your correspondence with us. By cutting down on time in handling it will speed our replies to you.

The ZIP number should be placed at the end of your address — after the state. Our address, for example, is now:

National Radio Institute
3939 Wisconsin Avenue
Washington, DC 20016

Sideband Communications

A REVIEW OF MODERN AM COMMUNICATIONS SYSTEMS

By

TED BEACH

NRI STAFF

You may have heard of sideband communications at one time or another, but just what is it? Actually, all forms of radio communications, AM, FM, PM, TV, etc., make use of sidebands in transmitting information from one place to another. However, all these systems have one thing in common: a radio frequency carrier. Sideband communications systems, on the other hand, transmit ONLY the sidebands and NOT the carrier. This article will show how this is accomplished and discuss some of the advantages and disadvantages of the system.

Who Needs a Carrier?

Sideband communications is basically a form of the old familiar amplitude modulation (AM, or as some hams call it: Ancient Modulation). For this reason a good starting point for understanding sideband might be with a quick look at AM.

As soon as CB Sam punches the transmit button on his 5-watt powerhouse, his channel 9 crystal begins to quiver and quake. These physical gyrations of the number nine rock produce minute electrical signals that are strengthened by vacuum tube or transistor until they finally emerge as a 3-watt giant in the CB band. This assumes that his 5-watt final operates with an efficiency of 60%.

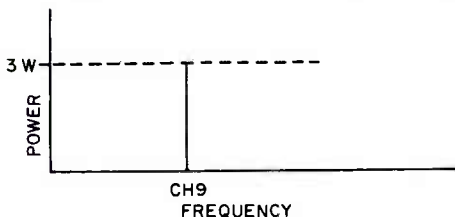

FIG. 1. A 3-watt carrier on CB channel 9.

Otherwise, the radiated carrier would be even less than 3 watts for a 5-watt input. This unmodulated "carrier" sits there QRMing other stations and consuming vast amounts of electrical power from Sam's car battery until he begins to talk. This 3-watt carrier is shown in Fig. 1.

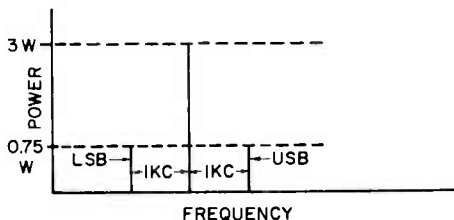

FIG. 2. A 3-watt carrier modulated 100% with 1-kc signal. The power in each sideband is 0.75 watts.

Next Sam begins to whistle into his microphone (to check it out?). If everything is operating properly, and assuming Sam can whistle a pure 1-kc note loud enough to modulate his carrier 100%, the results are shown in Fig. 2. The 3-watt carrier has been joined by two 0.75-watt rf signals displaced 1 kc above and 1 kc below the carrier in frequency. These are the upper and lower sidebands respectively and are the result of the 1-kc modulating signal.

Notice in Fig. 2 that with 100% modulation the power in each sideband is only 0.75 watts (assuming 60% efficiency of the final amplifier). The carrier power, on the other hand, is 3 watts. In other words the power in each sideband is only 25% of the carrier power. When Sam begins to talk into the microphone there will be many more signals produced above and below the carrier. However, assuming he will modulate the carrier 100% with each of the speech frequencies the

TOTAL power in each sideband will still be only 0.75 watts. Not a very bright picture, is it?

The whole purpose of this 3-watt carrier is merely to establish a reference for the sideband signals so the modulation can be recovered at the receiver. At the detector of the receiver, the upper and lower sidebands beat against the carrier producing sum and difference signals. The difference signal between each sideband and the carrier is the original modulating signal:

USB - Carrier = modulating signal
Carrier - LSB = modulating signal

Thus, the 3-watt carrier serves no other purpose than establishing the location of the sidebands in the frequency spectrum and helping detect (demodulate) the sidebands at the receiver. Actually the carrier could just as well be left at home and a "carrier" introduced at the receiver could demodulate the received sidebands as well or better than the transmitted carrier. This is exactly what is done in a double sideband suppressed carrier system (DSB for short).

Double Sideband

Let's take the AM citizens band rig discussed earlier and see how it might operate as a DSB transmitter. DSB transmission results when only the upper and lower sidebands are transmitted and not the carrier. Just how is this done? Possibly we could generate a conventional AM signal and then trap out the carrier with a very sharp filter circuit. This, however, is not a very practical approach for two reasons. First, the lower modulating frequencies produce sidebands that are very close to the carrier - only 200 to 300 cycles away. A filter which would eliminate the carrier and not the lower modulating frequency sidebands would be very expensive and difficult to design. Second, why generate a powerful carrier only to suppress it? This would be wasted effort.

Actually we do have to generate a low level carrier, but not for producing an AM signal. The carrier is generated at a very low level and, when applied to a special type of modulator called a balanced modulator, is balanced out so that it does not appear in the output. Fig. 3 shows two simple balanced modulators. In Fig. 3A the carrier (rf) is fed to the grids of the two tubes in push-pull. The tube plates are connected in parallel, thus no carrier energy will be present at the output if the circuit is properly balanced. When a modulating signal (af) is applied in parallel to both grids, the balance is upset and rf energy appears in the output in pro-

portion to the amount of unbalance caused by af. This is the required DSB signal.

Fig. 3B is a simple series diode balanced modulator. The carrier (rf) flows through the upper and lower halves of the tank circuit when D_1 and D_2 conduct on positive and negative peaks respectively of the carrier. These tank currents cancel so that no carrier energy appears at the output. When a modulating signal is present the effect is to bias the diodes so that one conducts more heavily than the other, thus unbalancing the circuit. DSB energy will appear at the output.

If the CB transmitter discussed earlier was capable of supplying a 3-watt carrier and 0.75-watt sidebands it is possible that the same final amplifier can supply 3 watts of sideband power alone as shown in Fig. 4. Merely by removing the useless carrier we are able to transmit TWICE the sideband power the same AM transmitter could handle!

Notice also that when there is no modulation, there is no output from the transmitter. This gives two big advantages. First, there is less interference to other communications since there is no carrier. Second, the power is supplied to the antenna by the power supply circuits only when there is a modulating signal present. This allows tubes and power supply to "rest" in between words and sentences, giving more efficient overall operation. In fact, because of the frequent rests given the output tube and power supply, considerably more power output could be ob-

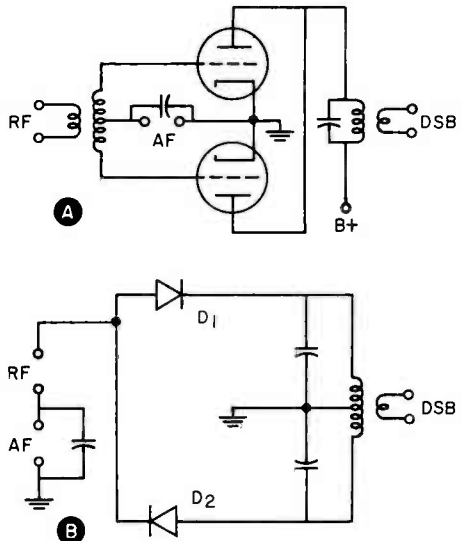

FIG. 3. These are two simple balanced modulators. They are (A) vacuum tube and (B) diode.

tained from them without fear of overloading something. For example, an output tube rated at 3 watts AM could conceivably be operated at 6 or 10 watts DSB with no ill effects. This is an added feature of sideband communications systems.

by slightly unbalancing the balanced modulator at the transmitter.

The next sideband system to be discussed is by far the best system. It will get through crowded bands and atmospherics when other

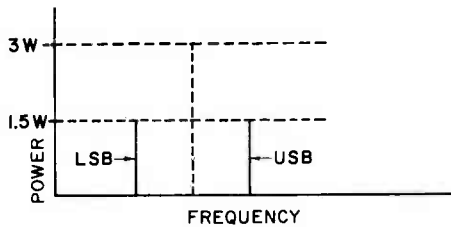

FIG. 4. A DSB signal: 1.5 watts in each sideband.

The DSB signal shown in Fig. 4 would be undetectable by an ordinary AM receiver. The sidebands, having no carrier to beat against, will beat against each other to produce an unintelligible output. In order to recover the modulating signals, a carrier must be added at the receiver. Here is where the rub comes. In order to demodulate the DSB signal the reinserted carrier must be at exactly the same frequency and exactly in phase (or 180° out of phase) with the suppressed carrier. Otherwise the output will be distorted and unintelligible. The carrier must be within 10 cycles of the suppressed carrier and the phase within 10 to 15 degrees for good demodulation.

Thus it would appear that while making the DSB transmitter simpler and more efficient, the DSB receiver is more complex. This is actually the case. However, the added reliability of the DSB system often offsets these disadvantages.

In order to simplify the DSB receiver characteristics, it is often possible to transmit

systems fail, and will operate with greater efficiency. In addition, the stringent receiver requirements of DSB are unnecessary with this system. It is called single sideband.

Single Sideband

Each of the two sidebands produced in either DSB or AM contains exactly the same information. So it would seem that it is not necessary to transmit both sidebands. Having suppressed the carrier in DSB, let's go one step further and suppress one of the two sidebands. Look what we will gain:

- (1) All the power output is useful power.
- (2) Channel bandwidth is cut in half.
- (3) Receiver requirements simpler than DSB.

With regard to (1) above, our original 3-watt rig with 0.75 watts in each sideband could be a 3-watt single sideband transmitter as shown in Fig. 5. The entire efforts of the transmitter go into one useful sideband rather than into two sidebands and a carrier.

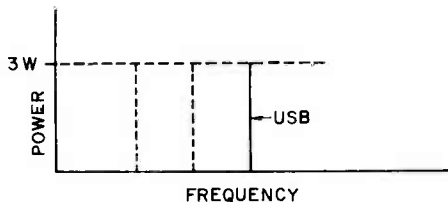

FIG. 5. SSB signal with 3 watts of sideband power.

a pilot or vestigial carrier along with the DSB signal. This allows the local carrier in the receiver to zero beat and become synchronized accurately with this pilot carrier to ease the receiver tuning requirements. It is an easy matter to produce the pilot carrier

The frequency spectrum occupied by the SSB signal is just half that of a DSB or AM signal. Conceivably two SSB stations could use the same frequency at the same time if one used upper sideband and the other lower sideband operation without interfering with one another.

other. In actual practice, it has been demonstrated both by military and amateur communications that more SSB stations than AM stations can operate in a given frequency spectrum without interference.

At the receiving end, SSB is as easy to receive as a CW telegraph signal and almost

frequency. In addition, since the SSB signal is generated at a relatively low power level it must be amplified to obtain useful power output. These amplifiers must be LINEAR amplifiers (class A, AB, or B) in order not to distort the SSB signal. All these things tend to make a filter type SSB transmitter complex, as shown in Fig. 8.

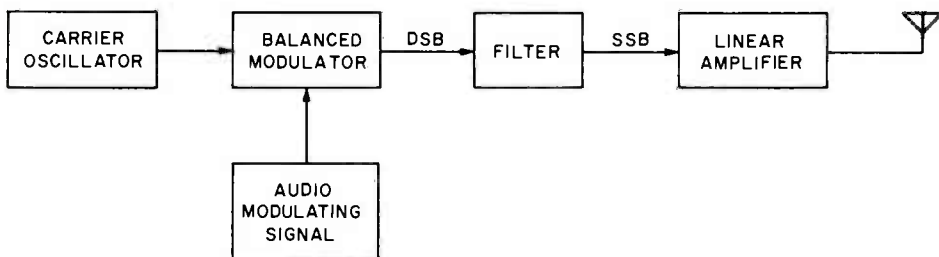

FIG. 6. How a double sideband is passed through a bandpass filter to eliminate the unwanted sideband.

as easy as an AM signal. A carrier must be inserted at the receiver, just as in DSB reception. However, the strict phase and frequency requirements are missing. As long as the carrier is reinserted within 50 cycles of the suppressed carrier, the SSB signal will be demodulated intelligibly. Phase is entirely irrelevant with SSB.

The SSB signal may be generated in either of two ways: by the filter method or by the phasing method. In the filter method, a DSB signal is produced which is passed through a bandpass filter to eliminate the unwanted sideband. This is shown in block form in Fig. 6.

In order to make the filter design as simple and efficient as possible, the SSB signal is usually generated at a low frequency. This is because the relative separation between the lowest sideband frequencies is greater at lower carrier frequencies than at higher carrier frequencies. For example, for a 100-kc carrier and a 300-cycle modulating signal, the upper and lower sidebands are 100.3 kc and 99.7 kc respectively. This is a separation of 0.6% minimum between sidebands. For a carrier of 1000 kc and the same modulating signal, the sidebands are 1000.3 kc and 999.7 kc giving a separation of 0.06% between sidebands. It is much easier to design a filter having a sharp cutoff for frequencies separated 0.6% than 0.06%. Fig. 7 shows this sideband separation on a frequency spectrum basis.

Because the filter generated SSB signal is produced at a single low frequency (determined by the filter) it is usually necessary to use a frequency changer or heterodyne mixer to get the signal to the operating fre-

quency. The second general method of generating SSB is the phasing method. This method is sometimes called the direct method since the SSB signal may be generated at almost any frequency and power level. However, it is general practice to generate the signal at a low level at the desired operating frequency and use linear amplifiers to get the desired power output.

Fig. 9 is a block diagram of a phasing type SSB generator. It uses two balanced modulators fed with rf signals that differ in phase by 90° . In addition, the modulating signal is split up into two components that differ in phase by 90° . These signals also go to the two balanced modulators. When the DSB outputs of the two modulators are properly combined, the desired sideband will be reinforced and the unwanted sideband attenuated. Sidebands may be switched simply by changing the phase of either the modulating signal or the rf signal by 180° .

Conclusion

This, then, is briefly what sideband is and how it is used. It is not the full story, however - it

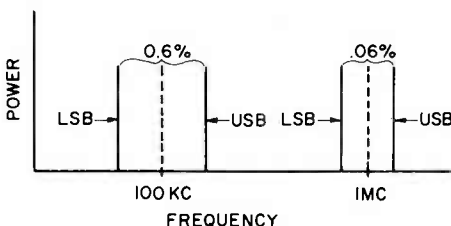

FIG. 7. Sideband separation at two frequencies.

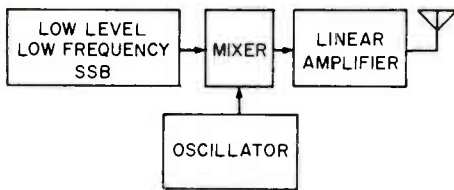

FIG. 8. A block diagram of an SSB transmitter.

would take volumes to relate all the pros and cons of sideband, and unless you have heard and seen what sideband can do, these volumes would not convince you.

It is easy to imagine what a pleasure it would be to carry on radio communications on a band with no annoying carriers. Instead of having to strain to dig out weak signals from

underneath mammoth pile ups, one would merely have to put up with a slight background "monkey chatter" type of interference. This type of interference is easy to overlook and is not in the least fatiguing to the listener.

Although sideband communications have been with us a long time (Bell Telephone has been using sideband since 1930), it is only within the last two decades that any real interest has been shown in it. This was due primarily to conceptions that sideband was complicated, costly, and difficult to use. However, sideband communications today are assuming the important position in day-to-day use they deserve. Several CB manufacturers are now marketing DSB reduced carrier transceivers. Others are developing SSB rigs. Perhaps in the near future ALL communications will be sideband communications.

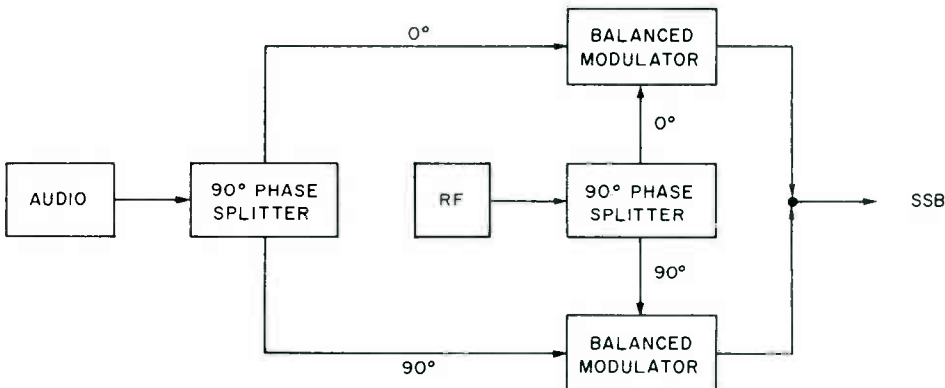

FIG. 9. A phasing type SSB generator that uses two balanced modulators which differ in phase by 90°.

Human Error Causes Most Highway Accidents

Nearly nine out of every 10 casualties on the nation's highways in 1962 were caused by human error and lack of judgment. And the speedster still ranks as the Number One Killer on the road.

These and other grim reminders were disclosed in a report issued by The Travelers Insurance Companies. The report is compiled annually from information provided by state motor vehicle departments.

Of the 40,500 persons who lost their lives in traffic accidents last year, 32,300 died in accidents caused by driver error and traffic law violations.

The fast driver continued to be the greatest menace on the highways. Nearly 13,000 deaths and more than 1,145,000 injuries were directly attributable to excessive speeding.

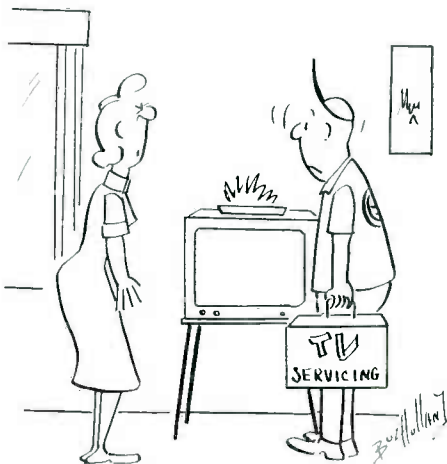

"And just before it went out, it went.
woooooeaaaahhhheeeewoooooeeee.
POW!"

ANTENNAS FOR FM STEREO

OUTDOOR ANTENNAS FOR RADIO

MAKE A COMEBACK

BY

HARRY TAYLOR

NRI STAFF

Public interest in stereophonic sound in general and FM multiplex stereo in particular, has created a tremendous need for personnel thoroughly trained in all phases of FM stereo. Probably the most neglected area of FM stereo is the antenna system.

In recent years, outdoor TV antennas have all but disappeared in metropolitan reception areas. Viewers have learned to accept the reduction in picture quality resulting from the use of indoor antennas. The ease and economy of installation as well as the desire to avoid "cluttering up" the roof with an antenna system has led to the widespread use of indoor FM antennas also. Antennas can be found stapled to baseboards, cabinets, sofas, set up in attics, and disguised as flowers, lamps or window screens.

This is ironical in that without a suitable antenna, no system can perform well. Many listeners go to the expense and effort of selecting and matching the "finest" multiplex adapter, tuner, amplifier and loudspeaker, but have to settle for much less than the best sound. Others have purchased multiplex adapters for use with existing tuners, only to find that the sound quality is too poor for comfortable listening. Because of the importance of a good signal at the input to the tuner, the following is offered to aid you in selecting and installing antenna systems to overcome these problems.

First of all, when compared to monophonic, FM stereo requires a much stronger signal for the same quality of sound. Owners of FM tuners living in outlying areas where mono quality is good learned this when they installed multiplex adapters.

The FM station employs its rated power to transmit the single audio signal in a monophonic broadcast. The FM multiplex stereo signal consists of three separate signals which the transmitter must broadcast. The station cannot increase its output power.

Therefore, the strength of each of the three parts of the signal is greatly reduced. This calls for the installation of a better antenna to pick up a greater amount of the available signal.

FM broadcast stations operate in the VHF frequency range from 88 to 108 megacycles while standard AM stations transmit between .5 and 1.6 megacycles. Higher frequencies tend to travel in a straight line, commonly called line-of-sight transmission, while lower frequencies can travel long distances by reflection back to the earth or, in some cases, follow the curvature of the earth. Most of the FM signal transmitted skyward penetrates the upper atmosphere and continues into space. A small percentage is reflected back to earth, however. The signal sent out in a horizontal plane can be picked up directly at a distance of 30 miles. This horizontal signal bends somewhat, making it possible to receive the signal at distances up to 60 miles. This gives us the zones of reception illustrated in Fig. 1. Within 15 miles is considered local; between 15 and 40 miles is

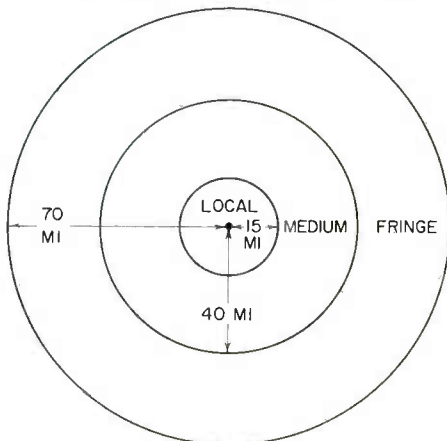

FIG. 1. Zones in which an FM signal is received.

called medium range, and from 40 to 70 miles is distant or fringe. Satisfactory reception is nearly impossible beyond 70 miles.

In many cases, monophonic reception is quite good in the local area without any antenna. Generally, at the most, a simple dipole antenna is sufficient. The quality of the sound does not seem to suffer. As the distance from the transmitting station increases, the antenna requirements become more rigid. Antenna wavelength, gain, directivity, and impedance become important. The antenna must channel a greater percentage of the available signal power into the receiver if the system is to reproduce acceptable sound.

Basically, FM antennas are similar to TV antennas. The FM band is within the TV frequency spectrum and as a result both TV and FM signals encounter the same problems. All types, from indoor "unipoles" and "rabbit ears" to the most elaborate outdoor antenna arrays have been used successfully.

In addition to the need for sufficient strength, FM stereo requires an input rf signal which is free from multipath signal reflections. Similar reflections in a TV signal produce "ghosts" in the picture. Multipath reflections in FM stereo cause noise, distortion and even the loss of the stereo directional effect. Sound which should be on one channel can be heard on the other channel.

Buildings, mountains, bridges, etc., reflect rf signals much like a mirror or piece of white cloth or paper reflects light. The signal from the transmitter reaches the receiving antenna by a direct (line-of-sight) path and by an indirect reflected route. This is illustrated in Fig. 2. The reflected signal arrives later than the direct signal since it travels a longer distance.

At the receiver input, the two signals mix. Addition and cancellation takes place, resulting in a composite signal which often has both amplitude and phase distortion. In monaural listening, the limiter stages in the receiver can usually reject the variations in signal amplitude while the phase distortion is in the upper end of the i-f bandpass where it cannot be heard anyway.

As you know, the frequency range of 50 to 53,000 cycles per second is used for FM stereo. Thus, deterioration of any part of the rf signal can have a disastrous effect on the receiver sound output. The 19 kc pilot frequency is especially susceptible to these problems. At the transmitter, the level of the 19 kc is only 10% of the signal. Therefore, phase or amplitude distortion can cause loss of this pilot frequency which is vital to stereo separation.

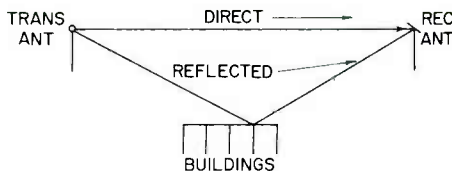

FIG. 2. Direct and reflected received signal paths.

Now that we have determined the requirements of antennas for FM stereo, let us see how they can best be met. Antennas have three basic characteristics on which they are rated: wavelength, gain, impedance and directivity. Different types of antennas excel in different characteristics.

Antenna wavelength is determined by the physical length of the antenna. The formula for wavelength is

$$\lambda = \frac{V}{F}$$

where λ is wavelength, V is velocity and F is frequency of the rf signal. The formula for antenna length is

$$\frac{\lambda}{2} = \frac{462}{F}$$

where $\frac{\lambda}{2}$ is one-half wavelength in feet and

F is frequency in megacycles. Using this formula, we can easily determine the physical length of a one-half wavelength dipole for optimum performance for 98 mc.

$$\frac{\lambda}{2} = \frac{462}{98} = 4.7 \text{ ft.}$$

The total length of the dipole should be 4.7 ft, or approximately 4 ft, 7-1/4 inches. We chose 98 mc because it is at the center of the FM band. When choosing any antenna, it is wise to select one which is cut to the center of the band of frequencies the antenna is expected to receive.

Antenna gain is measured in decibels, using the dipole as a reference. The signal power at the terminals of the dipole is called a gain of 1. Any antenna set up under the same conditions which picks up more signals, has a +db rating; an antenna producing less output signal power has a -db rating.

Wavelength refers to the resonant characteristic of the antenna. An antenna is a combination of lumped inductance, capacitance and resistance. Thus, it has a resonant frequency. This resonant frequency is determined by the physical and electrical dimensions of the antenna. For optimum perform-

ance, a dipole antenna should be cut to one half wavelength, so that it can absorb the maximum level of signal.

Directivity refers to the arc over which the antenna will pick up a usable signal. Directivity may range from a few degrees up to a full circle (360°), depending upon the type of antenna used. We are concerned here with directivity in the horizontal plane. Directivity is relative to gain. As the directivity is increased the antenna gain goes up.

For the maximum power transfer from the antenna to the receiver, the antenna characteristic impedance should match the impedance of the transmission line and the receiver input.

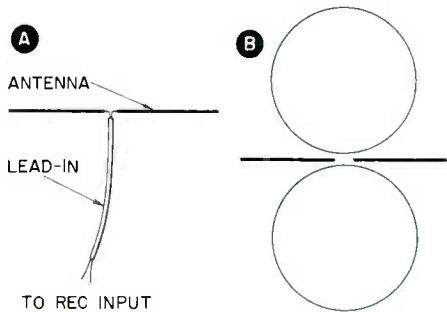

FIG. 3. Dipole antenna, A; directional pattern, B.

The basic dipole antenna, shown in Fig. 3, has a gain of 1, and the directional response shown. It is termed bidirectional because it will pick up signals equally well from two directions. The physical length of the dipole determines its resonance. The characteristic impedance of the antenna is approximately 72 ohms. A dipole can be used successfully in the local reception zone indicated in Fig. 1 if there is no problem of multipath distortion resulting from rf reflections. The impedance at the input to most tuners is 300 ohms. The impedance mismatch between the antenna and transmission is detrimental to signal quality. Therefore, an impedance-matching transformer should be used to overcome this problem when the 72 ohm dipole is used for FM stereo.

The folded dipole antenna illustrated in the sketch in Fig. 4 is widely used. It can be described electrically as two dipoles in parallel. In directivity and gain, the folded dipole is an improvement over the basic dipole. Its impedance is very close to 300 ohms. Thus, there are no special problems in achieving impedance match between the antenna and the tuner if regular 300-ohm TV lead-in cable is used.

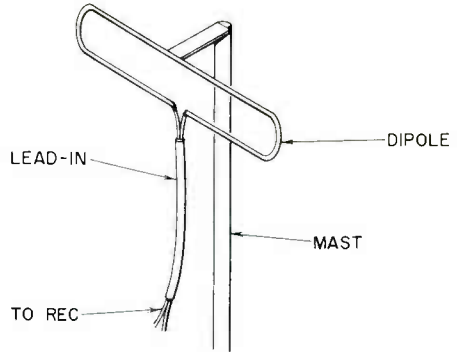

FIG. 4. A commonly used folded dipole antenna.

Third in popularity is another modification of the dipole. It consists of a dipole or folded dipole with a reflector. The reflector is called a parasitic antenna element in that it simply absorbs and re-radiates a part of the signal induced into the dipole. The reflector is physically and electrically longer than the dipole.

The dipole re-radiates approximately one half the signal induced into it from the atmosphere. The reflector is positioned so that it picks up the signal which passes to it from the dipole. The reflector, in turn, re-radiates most of this energy. The reflected signal adds to the signal induced into the dipole in the proper phase and reinforces it. Thus, a greater percentage of the signal initially induced into the antenna element is fed into the receiver or tuner.

By intercepting the signal radiated from the antenna element, the reflector increases the antenna gain when the signal approaches from the direction indicated by the large "lobe" or oval in Fig. 5. At the same time, notice that the combination folded dipole and reflector is relatively insensitive to signals

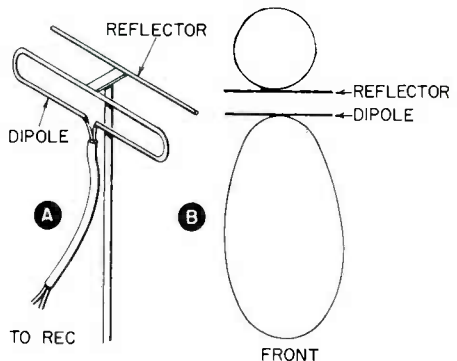

FIG. 5. A reflector added to the folded dipole antenna, A; shape of its directional pattern, B.

from the "back side." The reflector has a tendency to re-radiate signals from this direction before they reach the active antenna element. Thus, the signal is blocked and a smaller percentage is actually available at the antenna terminals.

The crossed dipole antenna consisting of two folded dipoles placed perpendicular to each other is used for omnidirectional reception. This antenna receives with nearly the same gain from all directions. Its gain is lower, however, than the basic dipole. Thus, it is not advantageous to use this antenna except in strong signal areas.

From the early day of television (before rabbit ears, 114° picture tube deflection and the unipole) you remember the yagi antenna. The yagi is similar to the folded dipole with a reflector. Actually, the yagi has both of these elements plus additional parasitic elements known as directors. Directors, which are shorter than the active element, are placed in front of the active antenna element to increase the gain from the front. They "store" the signal momentarily and feed it to the active element with such a phase relationship that the active element re-radiates less than 50% of the signal. Thus, the effective gain is increased.

Yagi antennas may have any number of elements. Up to a certain point, each additional element improves the antenna gain and directivity. Six element yagis, consisting of two folded dipoles, one reflector and three directors are not uncommon where gain is required. This type of antenna is illustrated in Fig. 6.

Earlier we stated that a dipole is usable in the local reception zone. This is true for both mono and stereo if multipath reflection is no problem.

There are no simple, easy rules for choosing an antenna except that it should give satisfactory performance. The right antenna is based on individual needs.

For local listening to one or more stations in the same general direction, a dipole (with an impedance-matching transformer or pad) or a folded dipole is often OK. If, on the other hand, the stations are scattered all around, the bidirectional pattern of the antenna will screen out the stations off both ends. You can solve this by using an antenna with omnidirectional response, or rotate the dipole when you tune in the stations.

Crossed dipole and turnstile antennas are usually effective under these circumstances. They have low gain (less than that of the di-

pole), but gain is not important here. They pick up signals with nearly equal strength from all directions, which is the primary reason for their use.

To reduce the effects of multipath distortion, a directional antenna such as a yagi can be used. If the transmitters are in more than

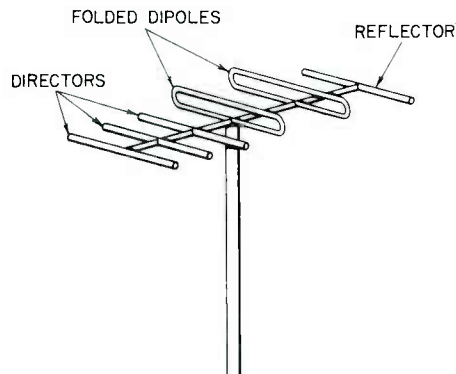

FIG. 6. A yagi antenna with six elements: two folded dipoles, one reflector and three directors.

one direction, you can use two antennas aimed in different directions, or use a rotator to aim the antenna for best reception.

Directional high-gain antennas are generally required in the medium range and fringe zones for stereo. A single yagi is often adequate if all stations are in the same direction. Where FM is to be received from two distant cities, two yagi antennas may be used - one aimed for each. A single yagi and the antenna rotator could be substituted.

At the outer reaches of the fringe zone, reception is often marginal with even a seven-element yagi. An "electric" antenna may make comfortable listening possible. The "electric" antenna is a yagi or other high-gain antenna with an rf preamplifier mounted on the mast. The preamplifier has a high signal-to-noise ratio to boost the signal before it is fed down through the transmission line to the receiver.

FM antennas are installed exactly like TV antennas. They should be placed where there is sufficient support and as little signal obstruction as possible. It is best to use a transmission line which matches the impedance of the antenna. If an impedance-matching device is needed, it should be placed at the receiver or be a part of the receiver.

A receiver is only as good as the signal applied to it. To get maximum quality of FM stereo sound, use a good antenna. (R)

A LOOK AT LASERS

by

JOE GRIFFIN

NRI STAFF

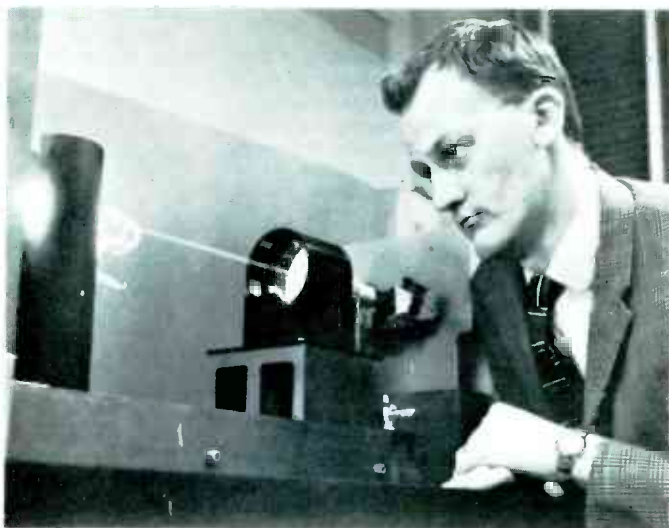

Courtesy Bell Telephone Laboratories

By now practically everyone has heard of the laser. Most of us associate the word laser with such spectacular feats as lighting the surface of the moon, or cutting diamonds with an intense beam of light. However, there are many other less spectacular, but equally significant, laser accomplishments, such as knifeless surgery of the eye (see Fig. 1), and accurate measurement of distances to targets. (See Fig. 2.)

communications and industrial purposes, such as welding. In view of this, a knowledge of electronics will be essential to understanding these new laser devices. And with the development of the systems listed above the present tremendous demand for trained electronics personnel will be increased. For the technician, or anyone else interested in electronics, this article may kindle an interest



Courtesy American Optical

FIG. 1. An eye specialist is shown using a new light instrument called a laser retina coagulator.

Countless revolutionary future applications are envisioned for this amazing new device. While many of these applications are predicted in such fields as weapon development and space travel, most of them will be in the field of electronics. These will include systems for ranging, surveillance, detection,



Courtesy Hughes Aircraft Company

FIG. 2. A new laser rangefinder that measures distances to target by firing a light beam.

around the nucleus of the atom, but they also rotate, or spin about their own axes. The size of the orbit and the rate at which an electron spins about its axis determines the amount of energy it possesses. The sum of the energies possessed by all electrons in an atom is the total energy contained in the atom.

A basic characteristic of atoms is their ability to absorb radiant energy, thereby increasing their total energy content. However, atoms can retain this excess energy only for a very brief period of time. When an atom takes on, or absorbs energy, it is said to rise to a higher energy level. When it gives up, or emits this energy, it is said to drop to a lower energy level. It is this basic characteristic of atoms which is utilized in laser operation.

To achieve laser operation, some form of matter, called the active element, must be irradiated, or pumped by light energy. The active element must exhibit certain properties which will enable it to interact with the electromagnetic, or light energy. One such form of matter that is used as an active element is the ruby. Ruby is essentially crystalline aluminum oxide (Al_2O_3) which contains chromium atoms substituted for some of the aluminum atoms. In a laser which uses ruby, the chromium ions are actually the active elements. Such a device is called a solid state laser.

A typical solid state laser constructed by

Bell Telephone Laboratories, and similar to the first laser developed by the Hughes Research Group, uses a synthetic pink ruby rod as the active element. Fig. 5 shows both the mechanical and electrical details of the construction of such a device. Both ends of the ruby rod are polished to an optical flatness of 2×10^{-6} inches and silvered. A more efficient, recently developed solid state laser is shown in Fig. 6.

The properties which an active element must have in order to function as a laser are (1) a broad pump level, (2) a metastable level, and (3) a ground level. (See Fig. 7.) Broad pump level means capable of absorbing a broad band of energy frequencies in white light. Metastable level means an energy level at which the atoms or ions can remain for a relatively long period of time. Ground level denotes the lowest, or normal energy level of the atom. (Fig. 8 shows a hydraulic analogy of three energy levels.)

Some of the active elements that have been used to obtain laser action to date are: chromium (ruby), neon, neodymium, dysprosium, holmium, praseodymium, samarium, thulium and uranium. Each of these elements displays unique properties. For example, chromium will operate as a laser at room temperatures, pulsed or cw, emitting light energy at a frequency in the visible region of the spectrum. On the other hand, thulium must be cooled to near 0 degree K temperature, and will only emit energy in pulses in the infrared region.

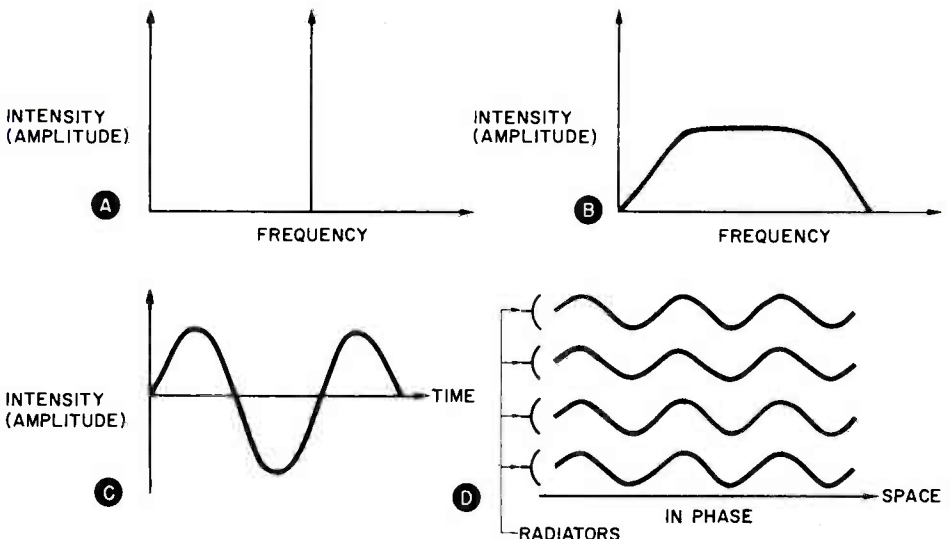

FIG. 4. Coherent versus incoherent radiation.

(THE FLASHLAMP AND RUBY ROD ARE HOUSED IN A CYLINDRICAL METAL HOLDER HAVING REFLECTING INSIDE SURFACES.)

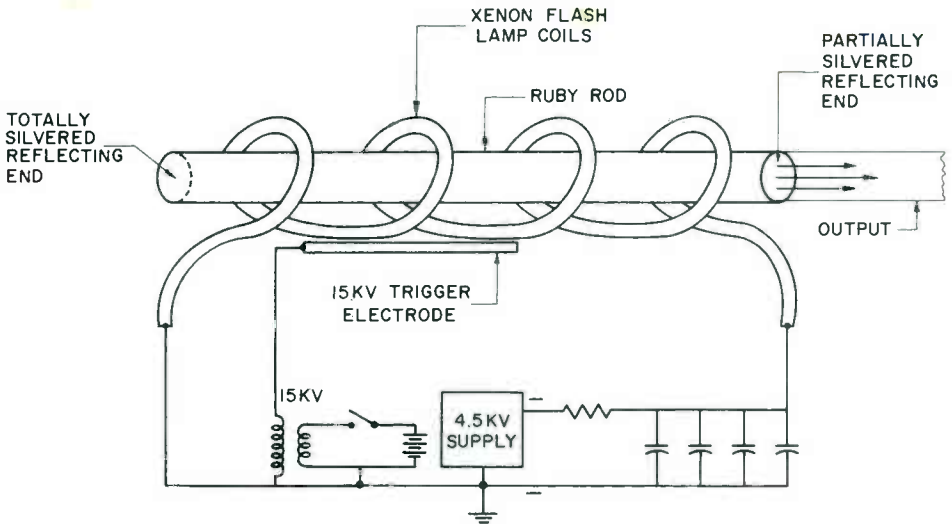
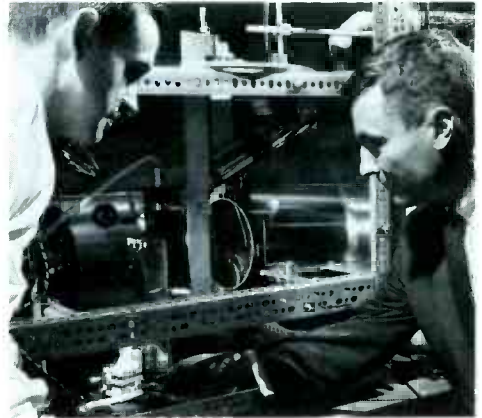

FIG. 5. (Above) Basic diagram showing details of a laser.

FIG. 6. (Right) A solid state laser developed by Bell Telephone Laboratories. This device is designed to convey pumping light to one end of a trumpet shaped crystal. Bell Laboratories prefers the term "optical masers."



Courtesy Bell Telephone Laboratories

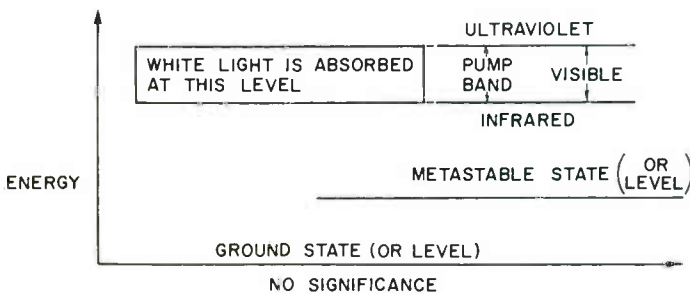

FIG. 7. (Left) This is a typical energy diagram of laser action.

From the above group of active elements you will note that neon (a gas) is listed as a laser material. The type of laser which uses this gas as the active element is called a gaseous laser. The first gaseous laser was developed by the Bell Telephone Laboratories. In this device, a tube filled with helium and neon is used instead of a ruby rod. This tube has optically flat ends, polished and silvered to make them only partially reflecting, and parallel to each other to within a fraction of a wavelength of light. Instead of being pumped



Courtesy Bell Telephone Laboratories

FIG. 9. Checking a group of gaseous lasers.

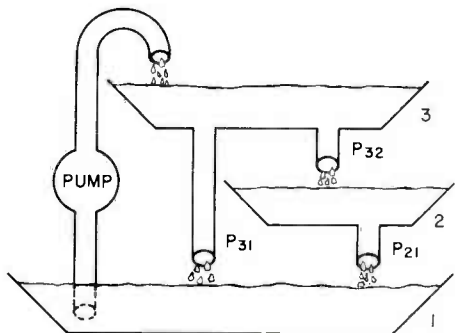
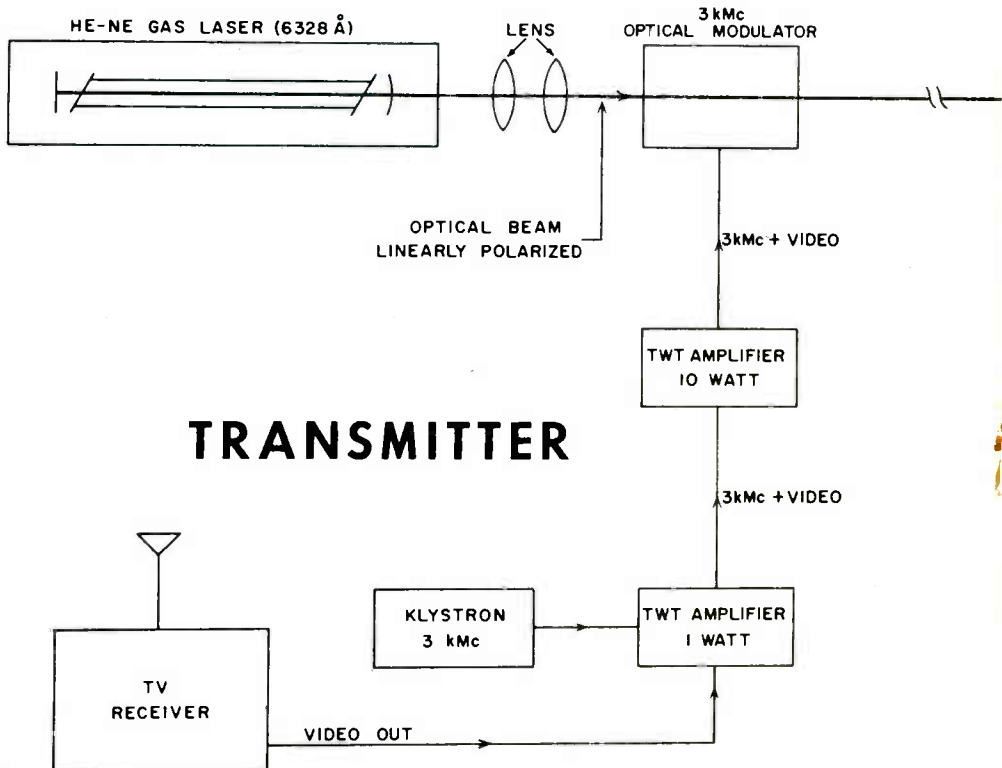

FIG. 8. Hydraulic analogy of three energy levels.

by visible light, this gaseous laser is stimulated by radio frequency energy at a frequency of 28 mc. Most of the rf energy is coupled to the helium gas and through collision with the neon atoms, energy is transferred from the helium atoms to the neon atoms. The emission from the gaseous laser has all of the properties of the emission from the ruby laser, except that the output power is less. This is because the atoms in a gas are less densely grouped than those in a solid. (A group of five gaseous lasers are shown in Fig. 9). Recently a gaseous laser has been developed which is stimulated by a dc po-



TRANSMITTER

tential instead of requiring an rf energy source.

The development of the laser makes operation in the optical range of the electromagnetic spectrum by electronic means possible for the first time. No doubt, many new devices making use of the newly discovered properties of light will be developed. The use of the laser in performing surgery of the eye will probably lead to further discoveries and applications in the field of medicine. Military interest was sparked by, among other things, the laser range finder developed by the Hughes Aircraft Company. This lightweight device is called the "Colidar" (for Coherent Light Detection and Ranging.) It accurately measures distances to targets, such as tanks, more than seven miles away.

General Telephone and Electronics Corporation has recently developed and demonstrated a laboratory model of a communications system which transmits and receives television pictures on a light beam generated by a laser device. A view of this system in operation is shown in Fig. 10 and a block diagram is given in Fig. 11.

A light gyroscope, far more sensitive than



Courtesy General Telephone & Electronics Corp.
 FIG. 10. A laboratory model of a communications system which transmits and receives television pictures on a light beam generated by a laser.

any other type of gyroscope, is also reported in operation. This device uses two laser beams directed in opposite directions and reflected by mirrors to form circular paths. A change in the beat frequency of these two beams which is caused by a change of position of the device, is detected. This is an appli-

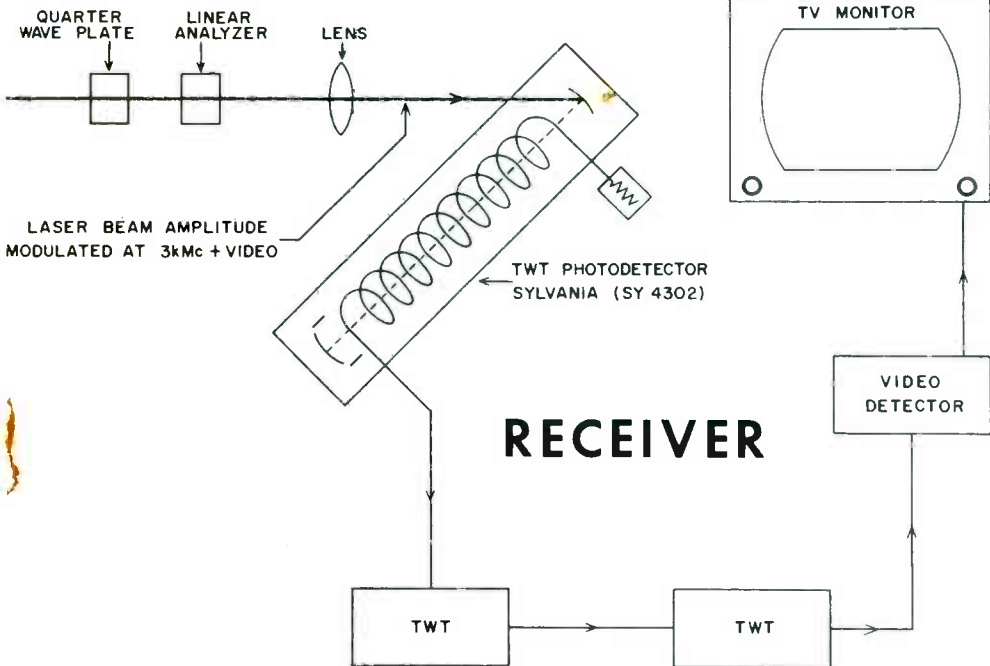

Courtesy General Telephone & Electronics Corp.

FIG. 11. A block diagram of an optical transmitter and receiver using a microwave subcarrier.



Courtesy American Optical

FIG. 12. An artist's conception of a sun-powered laser.

cation of the Doppler principle to a laser device.

Some future applications of lasers include a space radar thousands of times more accurate than any present system, a sun-powered laser communications system for satellite to satellite communication, or communication with other objects in space. An artist's conception of such a device is shown in Fig. 12. Also experiments are being conducted to determine the possibility of underwater communications via laser beams.

There are envisioned a variety of fantastic laser weapons which include lethal rays, light projectiles capable of destroying intercontinental ballistic missiles, and rays for blinding enemy troops.

As a laboratory tool, the laser will enable scientists to explore new areas of investigation. Many of the secrets of matter as well as of life itself may be revealed by the probing beam of laser light. The limits for the uses of this new and unique source of energy are determined only by the limits of human imagination.

In the field of electronics, the laser will command serious consideration as a future field of endeavor. Therefore, the reader should read every bit of material on laser developments as it becomes available. By doing this you will stay abreast of progress being made and you will be familiar with new devices that may appear on the market as a result of a possible sudden technological breakthrough in the field of laser development.

**Bit by bit . . . every
litter bit hurts!**

**KEEP AMERICA
BEAUTIFUL!**

Without freedom of thought, there can be no such thing as wisdom; and no such thing as public liberty without freedom of speech; which is the right of every man as far as by it he does not hurt or control the right of another; and this is the only check it ought to suffer and the only bounds it ought to know. . . . Whoever would overthrow the liberty of a nation must begin by subduing the freedom of speech, a thing terrible to traitors.

-Benjamin Franklin.



Geo Wilson

REDUCING SOLENOID HOLDING CURRENTS

by RONALD L. IVES

Direct current solenoids, commonly used to actuate relays and clutches, are most satisfactory devices when operation is intermittent, and when the ON phase of the operating cycle is short. When the ON phase of the operating cycle is long (more than a few minutes), and when the ON phase is longer than the OFF phase, multiple troubles tend to develop, largely due to heating.

This is a built-in trouble, as it commonly requires much more current to actuate a solenoid than it does to keep it actuated. In terms of applied voltage, the pull-in voltage considerably exceeds the holding voltage.

If, after the solenoid is actuated, we can reduce the sustained (holding) current, we can also reduce the coil heating, during the ON phase of the operating cycle. As coil heating is a function of I^2R , a slight reduction in the sustained current will produce a great reduction in the heating of the coil.

WORKING CIRCUIT

A suitable circuit for applying full voltage to a solenoid for initial actuation, and a reduced voltage for subsequent holding, is shown in Fig. 1. Here, when the switch is open, the capacitor charges to full battery voltage, in a very short time, through the series resistor, R_x .

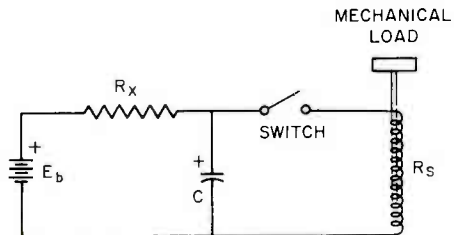

FIG. 1. A suitable solenoid control circuit.

When the switch is closed, this voltage is applied to the solenoid coil. Although the initial voltage applied is the full battery voltage, the voltage across the capacitor declines exponentially, at a rate determined by the circuit time constants, until it

reaches a steady state value determined by circuit resistances.

If the full battery voltage is that required to actuate the solenoid; and the steady state voltage that required to hold it in actuated position, our problem is solved. As the steady state voltage is somewhat less than the initial voltage, the coil heating, during holding, will be very much less than if the full battery voltage were applied continuously to the coil.

CHOICE OF CONSTANTS

If we were in engineering school, we would make careful measurements of all coil constants, specifically including resistance, minimum voltage to operate, minimum voltage to hold after operation, and operating time. From these figures, by means of rather involved formulas, we would compute the requisite values of R_x and C ; and, after spending approximately one man-day of engineering time, we would arrive at ideal values for the resistor and capacitor. We would most likely find that we needed a capacitor of 1785.224 microfarads; and a resistor of 12,316 ohms in series with the solenoid coil, which has a resistance of 24.912 ohms. Measured operating time averages 42,771 microseconds.

Now, as most solenoid-operated devices are similar in mechanical and electrical design, we can rapidly bypass most of the laboratory work and involved computation by use of simple approximations, and make final refinements, if necessary, by a bit of "cut and try".

The simple approximations are as follows:

- (1) The operating time of most simple solenoid devices is about 1/20 second (50,000 microseconds).
- (2) The holding voltage of most simple solenoid devices approximates 2/3 of the pull-in voltage.

From these simple empirical relations, we can immediately set R_x (Fig. 1) at 1/2 of R_s . This is a trial value which usually works, not a rigorously-proven "universal truth".

(Continued on page 22)

Dollar for dollar
your best buy
in kits is from

CONAR

Here's a selection of easy-to-build kits and electronic equipment from Conar — a fast growing name in the quality kit business. Every Conar kit is backed by a no-loopholes *guarantee* covering performance as well as parts! Take your pick at these exceptional prices and use the order form on the following page. Get set for hours of fun in assembly, years of trouble-free use, with kits from Conar, the instrument division of National Radio Institute.

VACUUM TUBE VOLTMETER

Model No. 211

One of the most useful pieces of equipment on the service bench or in the hobbyist's workshop. Big 6", two-color, jeweled meter. RMS and p. to p. scale. Input impedance, 12.2 megs. Simple, stable calibration. Shunting capacity is just 36 mmfd. An outstanding value.



KIT ONLY \$29.95
Assembled: \$44.95
#211WT

5" WIDE BAND PROFESSIONAL OSCILLOSCOPE

Model No. 250

- High sensitivity
- Brightest trace in a low cost scope!

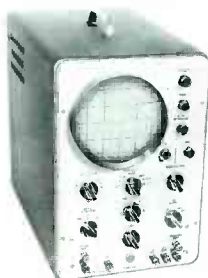

KIT PRICE: \$89.50
Assembled: \$139.50
#250WT

This Conar scope provides vertical sensitivity of .023 VRMS; horizontal sensitivity of 1.0 VRMS. Compare with any other popular priced scope and you'll find the Conar 250 way out in front. Features include built-in fly-back transformer tester, dynamic checking of vibrators, measuring ripple output of power supplies.

6 TRANSISTOR PORTABLE RADIO

Model No. 291

Assemble it in one evening, enjoy it for years. Big 4" speaker for console audio quality. Operates on 4 penlite batteries. Matched pre-aligned IF transformers; hi-Q loop; matched oscillator coil; leather-type case. Rugged. No printed circuits!



LOW KIT PRICE: Assembled:
\$23.95 | \$32.50
#291WT

TUNED SIGNAL GENERATOR

Model No. 280UK

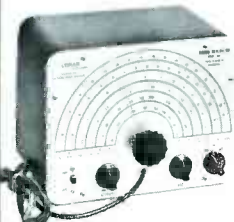

KIT ONLY \$24.95
Assembled: \$35.95
#280WT

A professionally styled unit designed for rapid, accurate AM-FM-TV alignment and troubleshooting. Average accuracy better than $\pm 1\%$ on all bands. Covers 170 kc to 60 mc on fundamentals; harmonic freq. coverage is over 120 mc. 9" dial.

POCKET-SIZE VOLTOHMETER

Model No. 240UK

Make accurate, essential AC and DC voltage measurements plus 3 resistance ranges. 20,000 ohms-per-volt sensitivity. Includes mercury cells, 48" test leads. Has jeweled d'Arsonval movement meter. Precision in a portable.



KIT PRICE: \$17.95
Assembled: \$19.95
#240WT

Conar is the
instrument
division of National
Radio Institute

CONAR

NEW! Conar breaks the price barrier on quality sound systems

"CUSTOM 300" 13 Unit STEREO SYSTEM



High-quality stereo does *not* have to be high priced! New, *low-cost* 13-unit stereo with complete set of balanced, matched components—*guaranteed* to produce highest listenable quality or money back! Includes 2 extended range, 8" hi-fi speakers; 2 ready-to-finish cabinets; stereo amplifier kit with steel case; cartridge with diamond stylus; record changer with balanced tone-arm, automatic intermix; all cables, etc. Nothing else to buy. Build it and play it the same evening!

Yours for a low, low **\$109.00** COMPLETE
30-DAY FREE TRIAL GUARANTEE!

LOW-COST RC TESTER

Model No. 311UK

\$21.95
KIT:

\$31.95

Assembled:
#311WT



Fast, accurate tests of resistors, capacitors—in and out of circuits. DC working voltage break-down test feature. Measures leakage, power factor, life. Shows exact value of resistors, opens, shorts.

TRANSISTOR BATTERY ELIMINATOR



Model No. 2WT
ONLY:

\$13.67

Not a kit. Use for designing, servicing, operating any type of portable, battery-operated unit. Continuously variable output. Only 4½" x 5". Price includes test leads and clips.

TUNED SIGNAL TRACER

Model No. 230UK

\$39.95
KIT PRICE:

\$57.50

Assembled:
#230WT



Includes exclusive, high imped. cathode follower probe. Built-in speaker. Tuning eye. Calibrated attenuators. Freq. coverage: 170 kc to 1500 kc on two bands.

MODEL 221 TUBE TESTER KIT

Every technician, full or part time, needs one. Tests *all* tubes, with built-in features to insure against obsolescence. 12 lever switches for checking latest tube types. Precise, balanced meter. Attractive, functional carrying case. Easy to build and use.



KIT PRICE:
\$39.50

Assembled:
\$57.50
#221WT

**USE HANDY
ORDER FORM
ON PAGE 21
EASY PAYMENT PLAN
ONLY 10% DOWN**

A TV Repairman's

LEADERSHIP
IN THE
TELEVISION
REPAIR
INDUSTRY

BY ARCHIE EDINGTON

Reprinted from
The Washington Star Sunday Magazine

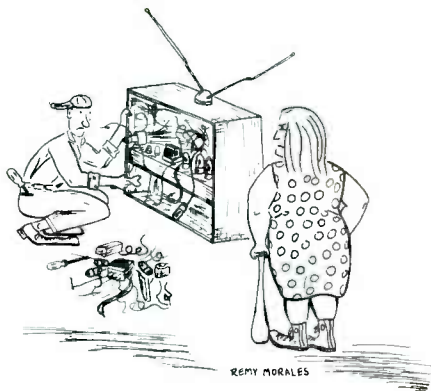

Too often we've all heard the TV serviceman criticized by the public. Here's how one decided to take arms and strike a blow in defense of the good name of his profession. Archie Edington owns a TV service and repair shop in Marlow Heights, Maryland.

While shopping in a supermarket recently I overheard one housewife tell another: "My television set still isn't working right. A newspaper ought to write an exposé on those television repairmen." My ears burned. Then I suddenly thought: "A television repairman ought to write an exposé on the public." I went further - I decided to write one myself, and here it is.

First, I'll grant that a few "fast-buck" artists operate in my business. Show me a business that doesn't have any. But they are in the minority. If you've been "taken" by one, you have a right to be angry with the "gyp artist" who conned you, but I don't think you ought to rap the TV service business in general.

The fringe operators and the incompetents, who certainly do their share of damage to the large numbers of honest, efficient servicemen, are not my chief complaint. After 14 years of servicing television sets - and doing an honest day's work for an honest day's pay - what I still cannot understand is the public's attitude.

Take the nominal service charge virtually all legitimate repair shops charge. Time and again I have had prospective customers hang

up the phone in my face when I told them the service charge was in the neighborhood of \$5. Just what did they expect? Do they want me to fix their set for nothing? The service charge includes the work done on the set in the home, and it costs about that much for you, the customer, to be able to find me, the repairman. There are costs for telephone, signs, advertising, rent, insurance, etc. Add truck expense, payroll, electric power and few other items and you can see how much of the \$5 is left over for me to pay the rent on my house.

I suppose I saw some of those people who hung up the phone in my face later - after they tried fixing the set themselves. Can I go out and buy a book for 35 cents and do your job? Well, many people think they can do mine. Have you ever looked inside a TV set? It is a complicated maze of wires, tubes and rods. It takes training and experience to learn what they all mean, what they do, and what it takes to repair them.

But look what happens: An amateur, who thinks he is going to beat what he considers the high cost of repair, ends up compounding the trouble and when we finally are called in, his bill is much higher than it would have been had he called us at the first sign of trouble.

There is such a thing as "preventative maintenance" for TV sets. The same people who take their cars to the garage for check-ups and grease-and-oil jobs, and who put anti-freeze in their cooling systems before the first frost, will not call a TV repairman when their picture starts getting fuzzy or when

Reducing Solenoid Holding Currents

(Continued from page 17)

From the assumed operating time (50,000 μ sec.), we can substitute in the formula:

$$T (\mu\text{sec.}) = R (\text{ohms}) \times C (\mu\text{f})$$

and obtain a probable value for the capacitor C. This formula can be simplified to:

$$C (\mu\text{f}) = \frac{50,000}{R (\text{ohms})}$$

for the purposes of this computation. In actual use, the next larger stock size capacitor is used.

After computation, the selected constants must be tested in actual service, and corrections made if necessary. In general, if the solenoid operates satisfactorily on the rated supply voltage, but will not pull in solidly, the capacitor is too small. If, after pulling in, the solenoid releases its mechanical load, the series resistor, R_x , is too large.

PRACTICAL EXAMPLE

Applying these general principles to a practical case, a small solenoid clutch was chosen, having a nominal operating voltage of 6, and a coil resistance of 25 ohms. Numerical value of the series resistor, R_x , is 12-1/2 ohms.

Nearest stock value, 12 ohms, was chosen. As the drop across this resistor is 2 volts, computed wattage is 4/12, or 1/3. A one-watt carbon resistor was used, to allow an ample margin of safety.

By substitution in the formula, the value of C is 50,000/25, or 2,000 μ f. This is a stock value, and a 2,000 microfarad, 15-volt capacitor was used. Bench tests showed entirely satisfactory operation with the values selected. Further testing showed that a 15-ohm resistor could have been used for R_x , but that operation became "iffy" with a 22-ohm resistor. To allow for ultimate aging and loss of capacitance of C, the 12-ohm resistor was left in circuit. To reduce and virtually eliminate both contact sparking and radio interference, a small silicon diode (F-6) was connected across the solenoid coil, with anode to system negative, and cathode to the "high" side of the coil. This effectively absorbs flybacks occurring when the circuit is opened.

With this circuit, holding current through the solenoid coil has been reduced to approximately 2/3 of the pull-in current. In consequence, as heating is a function of I^2R , heat production from the solenoid has been reduced to approximately 4/9 of its previous value. This heat reduction changed the status of the solenoid clutch from "always out of order" to "works fine".

CONAR EASY PAYMENT PLAN

Note: Easy payment contracts cannot be accepted from persons under 21 years of age. If you are under 21, have this sheet filled in by a person of legal age and regularly employed.

Enclosed is a down payment of \$_____ on the equipment I have listed on the reverse side. Beginning 30 days from the date of shipment I will pay you \$_____ each month until the total payment price is paid. You will retain title of this equipment until this amount is fully paid. If I do not make the payments as agreed, you may declare the entire unpaid balance immediately due and payable, or at your option, repossess the equipment. Your acceptance of this will be effected by your shipment to me of the equipment I have listed.

Date _____ Your written signature _____

CREDIT APPLICATION

Print Full Name _____ Age _____

Home Address _____

City & State _____ How long at this address? _____

Previous Address _____

City & State _____ How long at this address? _____

Present Employer _____ Position _____ Monthly Income _____

Business Address _____ How Long Employed? _____

If in business for self, what business? _____ How Long? _____

Bank Account with _____ Savings Checking

CREDIT REFERENCE (Give 2 Merchants, Firms or Finance Companies with whom you have or have had accounts.)

Credit Acct. with _____ (Name) _____ (Address) _____ Highest Credit _____

Credit Acct. with _____ (Name) _____ (Address) _____ Highest Credit _____

New Products



A uniquely compact bulk tape eraser, the smallest in size on the market, is being introduced by Freeman Electronics Corporation, 729 N. Highland Avenue, Los Angeles 38, California.

Accommodating reels up to seven inches in size, the Freeman BT-100 is highly efficient, lightweight for easy portability, and comes equipped with its own handsome carrying case. With this eraser, it takes only seconds to completely erase an entire reel. Background tape noise levels are reduced some 80% as compared to normal tape recorder eraser heads.

Standard Kollsman's all-channel television converters enable VHF TV sets (now receiving only channels 2 through 13) to receive the new UHF stations (channels 14 through 83) without expensive internal set conversion. The new converters simply attach to the antenna lead of television sets, and UHF signals are automatically changed into pictures and sound.



This miniature, extended service 120-volt pilot lamp (bottom center) has been introduced by the Lighting Products Division of Sylvania Electric Products Inc., a subsidiary of General Telephone and Electronics Corporation. The new lamp is engineered to provide a minimum of 3000 hours of static life at rated voltage. It does not require transistors or transformers when used on 120-volt circuits. Pilot lights (top) using the new lamp are 50 per cent smaller than similar standard voltage incandescent pilot lights offering significant saving of space in compact electrical and electronic equipment.

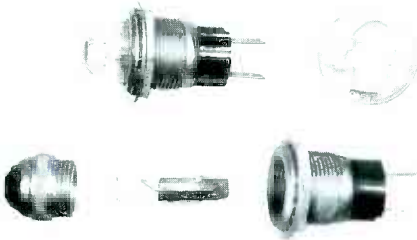

New back-pack radio gives Army communicator choice of 10,000 channels to get battlefield messages through. Developed by Raytheon Company, the single sideband set is rugged enough to work under the worst field conditions, yet sensitive enough to give clear crisp voice tones. Lack of a large number of channels available up at front lines has plagued military commanders for years. Range of set varies from 25 miles using ground waves up to several hundred miles via ionospheric skywave propagation.



NRI ALUMNI NEWS

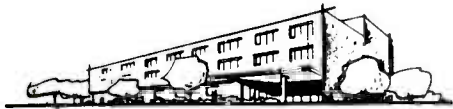

John Berka.....	President
Howard Tate.....	Vice President
James Kelley.....	Vice President
Eugene DeCaussin.....	Vice President
David Spitzer.....	Vice President
Theodore E. Rose.....	Executive Sect.

Nominations For 1964

One of the privileges -- and a duty -- of membership in the NRI Alumni Association is that the members choose their own national officers. There are five selected by vote each year: the President and four Vice Presidents.

First we will nominate the candidates by ballot. The two members for whom the greatest number of votes for President are cast will be the candidates for that office. The eight members for whom the greatest number of votes are cast for a Vice Presidency will be the candidates for that office.

Nomination of candidates must be completed by August 25, 1963. Your vote will count only if it reaches Washington by that date.

National Headquarters will tally the votes and publish the names of the candidates in the October issue of the NRI Journal. From among the candidates nominated the members of the Association will cast their votes for a President and four Vice Presidents. The necessary ballots will also be included in the October issue.

As always, the election is being conducted in accordance with Article VI, Section 2, of our Constitution and Bylaws.

John Berka's term as President will come to an end on December 31, 1963. He will be succeeded by the winning candidate on January 1, 1964.

The August-September, 1962 issue of the NRI News contained the following: "Another member who has come to the fore in the last few years is J. Arthur Ragsdale of the San Francisco Chapter. He was twice elected to a Vice Presidency for two consecutive years"

Ragsdale gave Berka quite a battle for the Presidency in last year's election. It would not be surprising if the membership again expressed a choice for Ragsdale as National Officer, this time as President.

Of our current Vice Presidents, Howard Tate

Page Twenty-Four

of Pittsburgh and Eugene De Caussin of Hollywood, Calif., are both eligible for reelection as Vice Presidents or for the Presidency. Because of the limitations imposed by Article VI, Section 2, of our Constitution and Bylaws, however, neither James Kelley of Detroit nor David Spitzer of New York City is eligible as a candidate for Vice President. They may, however, be candidates for President.

The names of other members who may be considered as candidates, selected according to geographical location, are given under "Nomination Suggestions." However, members may nominate any members of the NRIAA that they wish as candidates.

Because of its importance, we repeat: Fill in your ballot and mail it in plenty of time to reach Washington by August 25.

NRIAA Welcomes New Local Chapter

Graduate George Schalk of Ridgewood, N. J., made a visit to NRI on May 24, 1962. While here he talked with Ted Rose, Executive Secretary of the NRI Alumni Association, about the possibility of forming a new local chapter of the Association in New Jersey. The necessary spade work and preparations were undertaken by Graduate Schalk and Ted Rose, who were in contact with each other for the next several months.

Exactly a year later to the day, May 24, 1963,



NRI Executive Secretary Ted Rose administering the oath of office to officers of the new Hackensack Chapter. They are, left to right: George Schalk, George Schopmeier, Ole Svane, Matthew Rechner.

the new chapter was organized. Ted Rose and J. B. Straughn of the NRI Staff motored from Washington to attend the organizational meeting, which was held at the YMCA in Hackensack. The meeting was a lively one. One of the first items of procedure was to elect the chapter's first slate of officers: George Schalk, Chairman; Matthew Rechner, Vice Chairman; George Schopmeier, Secretary; Ole Svane, Treasurer.

Ted Rose installed the officers, J. B. Straughn gave a talk and demonstration on servicing transistor receivers, and the meeting was then turned over to Chairman Schalk for the first business meeting.

NRI students and graduates in the area should take advantage of the opportunity to participate in the new Hackensack Chapter. All will be welcome to attend the meetings. See "Directory of Local Chapters" for time and place.

Prize Winning Grad



Harry Laakson, at 15 a graduate of NRI's Radio-TV Servicing Course and an "A" student of our Communications Course, has been awarded grand prize in the Ashby High School Science Fair in Ashby, Mass. His exhibit was on oscillators.

Future Visits To Chapters

Last year J. B. Straughn, Chief of NRI Consultation Service, accompanied Executive Secretary Ted Rose on his annual visit to the various local chapters. Mr. Straughn's lectures and demonstrations on Radio-TV-Electronics were so enthusiastically received that he is going to repeat his visits again this season. Below is a tentative schedule of the visits. This schedule will be confirmed or modified in subsequent issues of the Journal.

CHAPTER	DATE
Southeastern Mass.	September 25, 1963
Flint (Saginaw Valley)	October 9, 1963
Detroit	October 10, 1963
New York	November 7, 1963
Springfield, (Mass.)	November 8, 1963

Philadelphia-Camden	November 11, 1963
Hagerstown	November 14, 1963
New Orleans	January 14, 1964
Minneapolis-St. Paul	April 9, 1964
Pittsburgh	May 7, 1964
Hackensack	May 29, 1964

All NRI students and graduates will be welcome at the meetings whether they are members or not. Take advantage of this chance to meet Mr. Straughn and to hear him lecture on Electronics. See "Directory of Local Chapters" on page 29 for information on time and place of meetings.

CHAPTER CHATTER

DETROIT CHAPTER held one meeting in which all the members present participated in a program about radar. Each member brought in and presented what he knew about it, but all were surprised to find how hard it is to get information about the subject.

Perhaps the best presentation was by Leo Blevins. He brought in a chart showing how radar works and explained it to the members. Jim Kelley, Chairman, contributed a magazine article explaining how radar is used to control highway traffic.

Many members attended the "Technirama 63" demonstration given by Philco in the Spring. In fact, quite a few of the members are attending these demonstrations in addition to the regular Chapter meetings.

FLINT (SAGINAW VALLEY) CHAPTER members had an interesting meeting in which a leading local wholesale house introduced the latest "Fireball Transistorized Ignition System for Automobiles," as a money-making idea for the Radio-TV serviceman. A representative explained how to install the system.

At the conclusion of the meeting a farewell party was given for Chairman Andy Jobbagy, who was leaving on a trip to Europe during which he will visit seven countries. He promised to give a report on his trip to the members at the September meeting. Andy's report ought to make a very interesting meeting indeed.

HAGERSTOWN (CUMBERLAND VALLEY) CHAPTER'S Chairman George Fuks conducts most of the talks and demonstrations at the meetings and is well qualified to do so. At one recent meeting he explained the operation of semi-conductors and was scheduled to lecture on transistors at the following meeting.

This Chapter, too, suspended meetings for

the middle of the summer. The next meeting will be held on September 12.

LOS ANGELES CHAPTER'S newest member is Joe McCart, Sunland. Welcome to the Chapter, Joe.

Chairman Gene DeCaussin gave a talk on business ethics, something that Radio-TV servicemen should always keep in mind in dealing with the public.

Gene also reported that he was very pleased to receive a visit from Chairman Dave Spitzer, of the New York Chapter, who dropped in at Gene's Radio-TV shop while on a trip to the West Coast. The two chairmen had an interesting visit.



J. B. Straughn, Chief, NRI Consultation Service, addressing the Minneapolis-St. Paul Chapter.

MINNEAPOLIS-ST. PAUL (TWIN CITY) CHAPTER'S tough dog nights have proved so popular that lately the Chapter has devoted most of its meetings to these sessions. The members like them and seem to get a great deal out of them.

There was no meeting held in July because so many members are away on vacation in that month. The regular meetings have now been resumed.

NEW YORK CITY CHAPTER'S First Vice-Chairman Frank Zimmer, at a meeting during which Chairman Dave Spitzer was on vacation in California, delivered an authoritative lecture on what to look for in buying HI-FI components and the important consideration of wattage. Al Bimstein gave a remarkably thorough account of the theory, practice and headaches involved in air conditioning, its installation and maintenance. Searching questions from the floor were answered comprehensively.

Various uses of the scope in television work continued to be demonstrated and this was carried over into an examination of the Chapter's breadboarded transistor radio. Frank Zimmer also discussed safe and unsafe values

of current for humans, and Secretary Joseph Bradley gave the Chapter's first talk on the basics of color production in color TV, mentioning some of the adjustments required in the three-gun kinescopes.

The chapter was particularly pleased to welcome four new members: Nicholas Sbilis, Anthony Siracusa, Marcos A. Toro, and Franklin Lucas. Congratulations to these gentlemen!

PHILADELPHIA-CAMDEN CHAPTER, as is its annual custom, celebrated its twenty-ninth anniversary in May with a social and buffet supper featuring hot dogs and sauerkraut, cold cuts, cheeses of various kinds, with the usual trimmings, and beer and cold drinks.

The Chapter is already making plans for the Thirtieth Anniversary Celebration. This promises to be the biggest and most ambitious party ever given by the Chapter. More about it will appear in the NRI Journal as the time for it approaches.

Bill Heath of Westinghouse TV delivered another one of his talks at a meeting of the Chapter. The members thought this was one of his best. He had a flock of door prizes and plenty of literature. He can always be depended upon to talk about his product with plenty of zest.

At this time the Chapter has only one new member to report instead of the usual several. He is Wico Van Genderen. Welcome to the lone new member!

PITTSBURGH CHAPTER was pleased to welcome Mr. Grant, field man for Delco Radio, as guest speaker. He spoke on transistor auto radio receivers and troubleshooting. He showed an interesting film on manufacturing the receivers, how the transistors were made, and on the printed circuits employed in them.

Scheduled for the July meeting was a 2-1/2 hour program to be conducted by Westinghouse on their TV and stereo lines.

Newest members to join the Chapter are John Evans, Julius Bakosh, and John Blyshak. We are pleased to number these newcomers among the membership.

SAN ANTONIO ALAMO CHAPTER's Serbando Cardenas gave a splendid talk on repairing transistor radios. He explained the transistor circuits and their repair from a practical standpoint, and prepared a large circuit diagram that could be seen by everyone as he dealt with the various circuits. Everyone was impressed by his knowledge of the subject and his ability to put his points over. The mem-

bers feel they are indeed fortunate to have such a man among them and are looking forward to more talks and demonstrations by Serbando.

The Chapter held its first social at Wolfe's Inn. There was no formal program, just a friendly get-together for members and their wives. In most cases it was the first time the wives had met. A delicious steak dinner with all the trimmings was served. All agreed that it was a very enjoyable evening.

The Chapter wishes once again to call attention to still another change in the time and place of its meetings, but it is believed that this change will be more or less permanent. The meetings are now held at 7:30 P. M. on the third Wednesday of each month at Beethoven Hall, 422 Perelda, next door to Olsen Radio Supply.

SAN FRANCISCO CHAPTER admitted Calvin Brinar and William Panakes to membership. Welcome to the Chapter, gentlemen!

Andy Royal gave an excellent talk on detectors and their R-C filters, pointing out how the filter removed the rf carrier and how the audio and avc voltage were developed. The discussion was quite detailed.

At the next meeting Art Ragsdale used block diagrams to discuss TV receiver operation. As an extra, he gave a skilled discussion of front end work, covering the incremental inductance type tuner and also the turret type tuner. The members were unanimous in their expression of appreciation of both of these talks.

SOUTHEASTERN MASSACHUSETTS CHAPTER members enjoyed a troubleshooting demonstration performed by John Alves on a TV receiver brought to the meeting by Ed Bednarz. The problem was to find a quick, sure method of locating shorts in a circuit containing a number of parallel branches. By disconnecting the branches at this junction point, the one containing the short (in this case, the yoke) was quickly isolated. The members felt they had learned a lot at this meeting.

SPRINGFIELD (MASS.) CHAPTER'S Norman Charest gave a demonstration on defective tubes and the effect they had on the picture.

As in former years, the Chapter has suspended meetings during July and August. A new program will go into effect at the September meeting, where all members will have a chance to see, hear, and ask questions. A different circuit will be demonstrated at each meeting.

Nomination Suggestions For Alumni Association Election

(Use Ballot on Page 28.)

O. M. White, Huntsville, Ala.
Jimmie M. Sanders, Decatur, Ala.
Steven Carroll, Tuscon, Ariz.
William J. Seiferth, Mesa, Ariz.
Troy H. Boyd, Fayetteville, Ark.
Barney K. McHenry, El Dorado, Ark.
Anderson P. Royal, San Francisco, Calif.
Peter P. Salvotti, San Francisco, Calif.
Fred Tevis, Los Angeles, Calif.
Joe Stocker, Los Angeles, Calif.
William Hendrickson, Boulder, Colo.
Robert W. Oberwetter, Colo. Springs, Colo.
James A. Lamardo, Stamford, Conn.
James E. Dulin, Waterford, Conn.
Benjamin J. Miller, Dover, Del.
Charles L. Glover, Claymont, Del.
Charles H. Dunham, Washington, D. C.
Arthur M. Thompson, Washington, D. C.
Victor L. Hastings, Orlando, Fla.
Stephen E. Pla, Key West, Fla.
Cary L. McDaniels, Atlanta 16, Ga.
James E. Wynn, Marietta, Ga.
Martin Gonzales, Weiser, Idaho
Glenn W. Dick, Burley, Idaho
Robert T. Johnson, Rockford, Ill.
Robert D. Bishop, Lincoln, Ill.
V. Allen Butte, Elkhart, Ind.
George Lilly, Jr. Gary, Ind.
Henry Reiners, Waterloo, Iowa
Glenn A. Burgess, Cedar Rapids, Iowa
William C. Carter, Manhattan, Kansas
Ronald M. Enger, Liberal, Kansas
George Ellis, Jr., Lexington, Ky.
Louis L. Weaver, Newport, Ky.
Mr. John M. Conrad, New Orleans, La.
Ronald J. Reed, New Orleans, La.
Warren E. Joy, Richmond, Maine
Dana W. Moulton, Jr. York, Maine
Francis Lyons, Hagerstown, Md.
George Fuiks, Boonsboro, Md.
Arnold Wilder, Agawam, Mass.
John T. Park, Ware, Mass.
Edward Bednarz, Fall River, Mass.
William Wade, Jr., New Bedford, Mass.
Paul Donatelli, St. Paul, Minn.
Walter Berbee, St. Paul, Minn.
Paul L. Crippen, Millington, Mich.
Robert Newell, Port Huron, Mich.
George Kelley, Ecorse, Mich.
Asa Belton, Detroit, Mich.
Isaac Brooks, Greenwood, Miss.
James V. Griffin, Jackson, Miss.
William A. Griffson, Independence, Mo.
Glenn W. Pinkel, St. Ann, Mo.
William A. Clark, Great Falls, Mont.
William L. Hover, Deer Lodge, Mont.
Donald D. Bradley, McCook, Nebr.
Marvin W. Witta, North Platte, Nebr.

Nomination Ballot

T. E. ROSE, *Executive Secretary*
 NRI Alumni Association,
 3939 Wisconsin Ave.,
 Washington 16, D. C.

I am submitting this Nomination Ballot for my choice of candidates for the coming election. The men below are those whom I would like to see elected officers for the year 1964.

(Polls close August 25, 1963)

MY CHOICE FOR PRESIDENT IS

.....
 City State

MY CHOICE FOR FOUR VICE-PRESIDENTS IS

1.
 City State

2.
 City State

3.
 City State

4.
 City State

Your Signature

Address

City State

Student Number

- Peter E. Peterson, Las Vegas, Nev.
- James S. Davis, Reno, Nev.
- Wayne R. Wooley, Concord, N. H.
- Richard A. Crossman, Keene, N. H.
- John J. Donahue, Madison, N. J.
- Raymond M. Hainls, Jr., Palmyra, N. J.
- Raphael F. Townsend, Alamogordo, N. M.
- John V. Lopez, Las Cruces, N. M.
- Frank Zimmer, Long Island City, N. Y.
- Ralph Pincus, Arverne, N. Y.
- Harry Gerdts, Jackson Hts., N. Y.
- James Eaddy, Brooklyn, N. Y.
- Joseph Bradley, New York, N. Y.
- Tim Hill, Greensboro, N. C.
- James C. Bean, Hickory, N. Y.
- Lester L. Allen, Bismarck, N. Dak.
- T/Sgt. Franklyn W. Kelley, Minot, N. Dak.
- Edward R. Sprigle, Toledo 12, Ohio
- Harry Mitchell, Cincinnati 45, Ohio
- James C. Hood, Norman, Okla.
- Jerry D. Meeh, Stillwater, Okla.
- Dean A. Reed, Springfield, Oreg.
- James D. Copple, Cottage Grove, Oreg.
- Jules Cohen, Philadelphia, Pa.
- John Pirrung, Philadelphia, Pa.
- Harvey Morris, Philadelphia, Pa.
- George Dolnik, Philadelphia, Pa.
- Charles Fehn, Philadelphia, Pa.
- William Lundy, Pittsburgh, Pa.
- Thomas Schnader, Irwin, Pa.
- Harold Rosenberger, Waynesboro, Pa.
- Alan D. Adams, Portsmouth, R. I.
- Raymond R. Roberts, Woonsocket, R. I.
- Ed Rathbone, Spartanburg, S. C.
- Joseph Pettifoul, Darlington, S. C.
- Ron Capelle, Moberidge, S. Dak.
- W. R. Williams, Sioux Falls, S. Dak.
- Ronald M. Burch, Knoxville, Tenn.
- Norman Broom, Chattanooga, Tenn.
- Lowell B. Patrick, Dallas, Texas
- Herbert B. Cross, San Antonio 5, Texas
- Frederick Broerma, Hyde Park, Utah
- Herbert Richardson, Price, Utah
- E. B. Brinnett, Richmond, Va.
- Jerry E. Canner, Danville, Va.
- Raymond C. Stearns, Springfield, Vt.
- Robert J. McWaters, North Bennington, Vt.
- Seth P. Hall, Takoma, Wash.
- Michael J. Hurley, Seattle, Wash.
- Edgel T. Gaston, Parkersburg, W. Va.
- Morton Parsley, Huntington, W. Va.
- H. W. Burgess, Burlington, Wis.
- Elmer E. Sned, Milwaukee, Wis.
- Gary Francis, Casper, Wyo.
- Donald Cook, Greybull, Wyo.
- Earnest E. Oxereok, Wales, Alaska
- Ronald Dudley, Burnaby, B. C., Canada
- Raymond T. Uemura, Honolulu, Hawaii
- Karl H. Zibell, Winnipeg, Man., Canada
- Carman MacDougall, Moncton, N. B., Canada
- Josiah Butt, Mt. Pearl, Nfld., Canada
- Fred MacPherson, Halifax, N. S., Canada
- Ronald Theriault, Ottawa, Ont., Canada
- Walter G. Dent, Regina, Sask., Canada
- Raymond Walsh, Montreal, P. Q., Canada

Directory of Local Chapters

Local chapters of the NRI Alumni Association cordially welcome visits from all NRI students and graduates as guests or prospective members. For more information contact the Chairman of the chapter you would like to visit or consider joining.

CHICAGO CHAPTER meets 8:00 P. M., 2nd and 4th Wednesday of each month, 666 Lake Shore Dr., West Entrance, 33rd Floor, Chicago. Chairman: Frank Dominski, 2646 W. Potomac, Chicago, Ill.

DETROIT CHAPTER meets 8:00 P. M., 2nd and 4th Friday of each month. St. Andrews Hall, 431 E. Congress St., Detroit. Chairman: James Kelley, 1140 Livernois, Detroit, Mich., VI-1-4972.

FLINT (SAGINAW VALLEY) CHAPTER meets 8:00 P. M., 2nd Wednesday of each month at Chairman Andrew Jobbagy's Shop, G-5507 S. Saginaw Rd., Flint, Mich., OW 46773.

HACKENSACK CHAPTER meets 8:00 P. M., last Friday of each month, Hackensack YMCA, 360 Main St., Hackensack, N. J. Chairman: George Schalk, 471 Saddle River Rd., Ridgewood, N. J.

HAGERSTOWN (CUMBERLAND VALLEY) CHAPTER meets 7:30 P. M., 2nd Thursday of each month at the YMCA in Hagerstown, Md. Chairman: Francis Lyons, 2239 Beverly Dr., Hagerstown, Md. Reg 9-8280.

LOS ANGELES CHAPTER meets 8:00 P. M., 2nd and last Saturday of each month, 5938 Sunset Blvd., L. A. Chairman: Eugene DeCaussin, 5870 Franklin Ave., Apt. 203, Hollywood, Calif., HO 5-2356.

MINNEAPOLIS-ST. PAUL (TWIN CITIES) CHAPTER meets 8:00 P. M., 2nd Thursday of each month, Walt Berbee's Radio-TV Shop, 915 St. Clair St., St. Paul. Chairman: Paul Donatell, 1645 Sherwood Ave., St. Paul, Minn., PR 4-6495.

NEW ORLEANS CHAPTER meets 8:00 P. M., 2nd Tuesday of each month at Galjour's TV, 809 N. Broad St., New Orleans, La. Chairman: Herman Blackford, 5301 Tchoupitoulas St., New Orleans, La.

NEW YORK CITY CHAPTER meets 8:30 P. M., 1st and 3rd Thursday of each month, St. Marks Community Center, 12 St. Marks Pl., New York City. Chairman: David Spitzer, 2052 81st St., Brooklyn, N. Y., CL 6-6564.

PHILADELPHIA-CAMDEN CHAPTER meets 8:00 P. M., 2nd and 4th Monday of each month,

K of C Hall, Tulip and Tyson Sts., Philadelphia. Chairman: John Pirrung, 2923 Longshore Ave., Philadelphia, Pa.

PITTSBURGH CHAPTER meets 8:00 P. M., 1st Thursday of each month, 436 Forbes Ave., Pittsburgh. Chairman: Thomas Schnader, RD 3, Irwin, Pa., 731-8327.

SAN ANTONIO ALAMO CHAPTER meets 7:30 P. M., 3rd Wednesday of each month, Beethoven Hall, 422 Pereida, San Antonio. Chairman: Jesse De Lao, 606 Knotty Knoll, San Antonio, Texas.

SAN FRANCISCO CHAPTER meets 8:00 P. M., 1st Wednesday of each month, 147 Albion St., San Francisco. Chairman: Peter Salvotti, 2534 Great Hwy., San Francisco, Calif.

SOUTHEASTERN MASSACHUSETTS CHAPTER meets 8:00 P. M., last Wednesday of each month, home of John Alves, 57 Allen Blvd., Swansea, Mass. Chairman: James Donnelly, 30 Lyon St., Fall River, Mass. OS 2-5371.

SPRINGFIELD (MASS.) CHAPTER meets 7:00 P. M., 1st and 3rd Saturday of each month at shop of Norman Charest, 74 Redfern St., Springfield, Mass. Chairman: Steven Chomyn, Powder Mill Rd., Southwich, Mass.

Bring Your NRI Tube Tester Up-to-date

Now in stock -- 1963 roll charts for NRI Models 70 and 71 tube testers.

Both charts are right off the press and list over 1,000 most used and newly introduced tube types. Chart comes to you complete with a special supplement listing foreign tube settings, many industrial type tube settings and list of seldom used tubes.

In all probability, your present roll chart is obsolete and should be replaced. To determine the age of your roll chart, simply roll it to the top and check the form number in left-hand margin. "(7-61)" means the chart was printed in July, 1961; "(5-59)" means May, 1959, etc.

The supply of new 1963 charts is limited. Order yours NOW -- and be equipped to test the several hundred new tube types which were introduced in 1962 and early 1963.

Use order blank page 21. Please be sure to give Model number of your tube tester. Price of new chart is \$2.25, postpaid.

NRI JOURNAL
3939 Wisconsin Ave.
Washington, DC 20016

Mr. Willard R. Velline
1322 S. 14th
Fargo, N. Dak.

25923-3

4A

Second-class
postage paid
at Washington, D. C.