

Volume 18, No. 4

April 1999

U.S. \$3.95

Can. \$6.25

Printed in the United States



# Monitoring Times

Your Personal  
Communications Source

**ACTION**

**ALERT:**

Anti-Scanner Bill  
Moves to Senate



## Antenna Special

### Aerial Magic Using Fractals

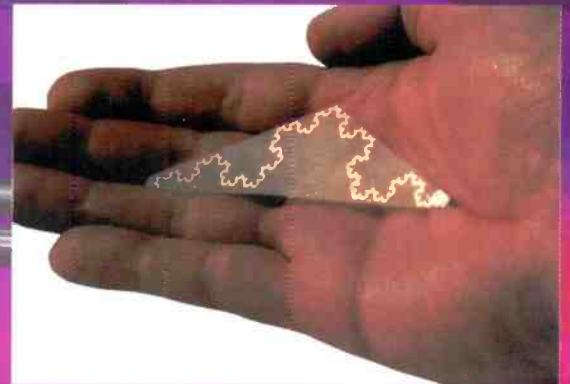

*Plus:*

- ✓ Random Wire or Backyard Beverage
- ✓ Build an L-Band Feedhorn



# The LITTLE Black Box with BIG Performance!

## OPTOCOM SETS THE STANDARD.....

Combining a high speed, high performance receiver, Motorola®/LTR Trunking, and full featured decoding.



Computer  
Not Included

INTRODUCTORY  
PRICE

**\$459**

FREE Trakkstar Software  
& Shipping

Order Now! Save \$90

## CHECK OUT THESE FEATURES

- High speed triple conversion GRE receiver board (50 channels per second)
- Track Motorola 400MHz, 500MHz, 800MHz, and 900MHz systems, as well as conventional frequencies, simultaneously
- Decode CTCSS, DCS, LTR, DTMF, and Motorola talk group ID
- Reaction Tune with the Scout Frequency Recorder
- Built-in Data Slicer Circuit for decoding of FSK programs
- Software and hardware controlled volume and squelch
- Download up to 28 different frequencies or one Talk Group ID for scanning without the computer
- Supplied with the all NEW TRAKKSTAR software from ScanStar
- Trunk Track LTR systems
- Scans conventional frequencies from 25-520, 760-823.995, 849.005-868.995, 894.005-1300MHz (Cellular frequencies are blocked except for FCC approved users)

Now Tracks EDACS™  
with Third Party Software

## Flexibility



Built-in data slicer circuit for decoding of popular FSK programs.

## Portability



For use without the computer, download up to 28 different frequencies or one talk group ID for mobile applications.

CC50 Carry Case  
Holds OptoCom & Laptop  
Computer.....\$25

**FACTORY DIRECT ORDER LINE 800-327-5912**

# OPTOELECTRONICS®

5821 NE 14th Avenue • Ft. Lauderdale, FL • 33334

Telephone: 954-771-2050 Fax: 954-771-2052 Email: sales@optoelectronics.com

Prices including Promotions and Specifications are subject to change without notice or obligation

[www.optoelectronics.com](http://www.optoelectronics.com) \*\*Shipping U/S Ground, continental U.S. only  
OPTOCOM supplied with Software, Antenna & Cables. Operates under Windows 3.1, 3.11, 95, and 98



# C O N T E N T S



## April Antenna Special

Vol. 18, No. 4

April 1999

### The Random Length Wire Antenna ..... 8

By Joseph Carr

Nearly every shortwave receiver manual will tell you that you can improve the performance of your set by connecting it to a random length wire antenna. But why does it do this; is reception improved equally over the spectrum and in all directions? Can you predict the results? Noted antenna author Joe Carr examines the theory behind this most common of all wire antennas.

### The Back Yard Beverage ..... 13

By Douglas Blakeslee



The Latin band at the bottom of the shortwave spectrum (also known as the tropical band, see Dec. 98 *MT*), poses its own peculiar challenge. The antenna of choice for DXing this band — and the AM broadcast band as well — is the Beverage antenna. But can you build a Beverage without a great deal of real estate? The author says, absolutely. Here's how.

### Constructing an L-Band Feed Horn ..... 16

By Stu Gerske

What are you supposed to hear in the upper gigahertz range of your new wideband receiver or scanner? Well, probably nothing without the right antenna — but with a satellite dish and this specialized feedhorn, you are on your way to picking up the fascinating communications and weather satellites to be found on L-band.



### A Volunteer for the CG Auxiliary ..... 20

By Dan Renfro

Not only do you not have to belong to the Coast Guard to be in the Auxiliary, you don't even have to be on the coast! Dan Renfro recounts the trials and tribulations of establishing a radio system on Lake Hickory, North Carolina.

### Reviews:



Bob Parnass says, for him, the tiny **Icom IC-R2** scanner was love at first sight (p.92). Another alternative-power radio has been added to Baygen's competition — the **Info-Mate 837**; Magne pits it against the original wind-up radio (p.90). You gotta get a license to use Motorola's new **TalkAbout Distance** Radio — it goes the distance by adding GMRS frequencies to FRS channels, but you can't access the repeaters (p. 87); **DXtreme SWRLgold V3.0** will make you throw away your paper log forever (p.88); those who have used spectrum display units find them indispensable but often unaffordable — the **AVCOM SDM42A** makes it cost-effective (p.96).

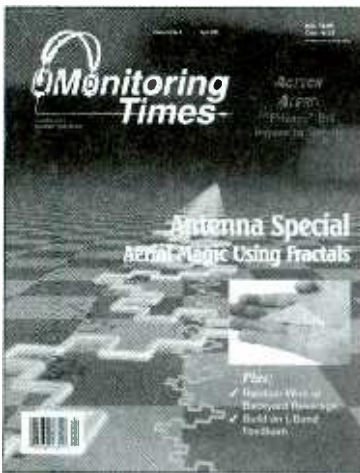

Cover Story

### Aerial Magic

By Mike May

Your mobile phone, the gas meter under the stairs and the vending machine down the hall could soon make use of a small, weird antenna that sprang from a ham radio operator's attempt to operate out of his Boston apartment ten years ago.

Repeating geometric shapes called fractals form the basis of a new approach to high-gain, small-size antenna construction. Our feature includes a sidebar by the inventor and some suggestions for doing your own experimenting. Story starts on page 22.

Our cover image is a study in fractal designs by John J. McDonough; The inset shows a tiny broadband monopole based on a fractal pattern (Patent Pending, Fractal Antenna Systems).



**MONITORING TIMES**  
 (ISSN: 0889-5341;  
 Publishers Mail  
 Agreement #1253492)  
 is published monthly by  
 Grove Enterprises, Inc.,  
 Brasstown, North  
 Carolina, USA.

Copyright © 1999 Grove Enterprises, Inc.  
 Periodicals postage paid at Brasstown, NC,  
 and additional mailing offices. Short excerpts  
 may be reprinted with appropriate credit.  
 Complete articles may not be reproduced  
 without permission.

Address: P.O. Box 98, 7540  
 Highway 64 West,  
 Brasstown, NC 28902-  
 0098  
 Telephone: (828) 837-9200  
 Fax: (828) 837-2216 (24 hours)  
 Internet Address: www.grove-ent.com  
 or e-mail: mt@grove-ent.com  
 Editorial e-mail: mteditor@grove-ent.com  
 Subscriptions: order@grove-ent.com

Subscription Rates: \$23.95 in US; \$36.50  
 Canada; and \$55.45 foreign elsewhere, US  
 funds. Label indicates last issue of subscrip-  
 tion. See page 103 for subscription  
 information.

Postmaster:  
 Send address changes to *Monitoring Times*,  
 P.O. Box 98, Brasstown, NC 28902-0098.

**Disclaimer:**  
 While *Monitoring Times* makes an effort to  
 ensure the information it publishes is accu-  
 rate, it cannot be held liable for the contents.  
 The reader assumes any risk for performing  
 modification or construction projects pub-  
 lished in *Monitoring Times*. Opinion or  
 conclusions expressed are not necessarily the  
 view of *Monitoring Times* or Grove Enter-  
 prises. Unsolicited manuscripts are accepted.  
 SASE if material is to be returned.

**Owners**

**Bob and Judy Grove**  
 judy@grove-ent.com

**Publisher**

**Bob Grove, W8JHD**  
 bgrove@grove-ent.com

**Managing Editor**

**Rachel Baughn, KE4OPD**  
 mteditor@grove-ent.com

**Assistant Editor**

**Larry Van Horn, N5FPW**

**Art Director**

**Belinda McDonald**

**Advertising Svcs.**

**Beth Leinbach**  
 (828) 389-4007  
 beth@grove.net

**DEPARTMENTS**

<b>Special Report</b> .....	<b>3</b>	<b>American Bandscan</b> .....	<b>76</b>
<i>Privacy Bill Resurrected</i>		<i>Beaming In</i>	
<b>Washington Whispers</b> .....	<b>4</b>	<b>Outer Limits</b> .....	<b>77</b>
<i>FCC Proposes Low Power Service</i>		<i>New Editors at Free Radio Weekly</i>	
<b>Communications</b> .....	<b>6</b>	<b>Below 500 kHz</b> .....	<b>78</b>
<b>Scanning Report</b> .....	<b>26</b>	<i>April Showers Towers</i>	
<i>Consumer Electronics Show 1999</i>		<b>PCS Front Line</b> .....	<b>80</b>
<b>Utility World</b> .....	<b>30</b>	<i>Touching Bases</i>	
<i>Sunspots: Stand by for Action</i>		<b>Experimenters Workshop</b> .....	<b>82</b>
<b>Digital Digest</b> .....	<b>33</b>	<i>Dual Polarity Power Supplies</i>	
<i>Catch Coquelet-8 before it's too Late</i>		<b>Antenna Topics</b> .....	<b>84</b>
<b>Global Forum</b> .....	<b>34</b>	<i>Just What Does an Antenna Do?</i>	
<i>Sunspot Peak; BBC Comes Clean</i>		<b>On the Ham Bands</b> .....	<b>86</b>
<b>QSL Report</b> .....	<b>38</b>	<i>W6SAI HF Antenna Handbook</i>	
<i>Sign of the Times - Part Deux?</i>		<b>And More!</b> .....	<b>87</b>
<b>English Lang SW Guide</b> .....	<b>39</b>	<i>Motorola's TalkAbout Distance GMRS</i>	
<b>Propagation Conditions</b> .....	<b>60</b>	<b>Computers &amp; Radio</b> .....	<b>88</b>
<i>Bibliography of the Sun</i>		<i>Xtremely Useful Paperless Logging</i>	
<b>Programming Spotlight</b> .....	<b>61</b>	<b>Magne Tests</b> .....	<b>90</b>
<i>OK, Where Do I Start?</i>		<i>Emergency Radio: Info-Mate 837</i>	
<b>Satellite Radio Guide</b> .....	<b>62</b>	<b>Scanning Equipment</b> .....	<b>92</b>
<b>The Launching Pad</b> .....	<b>66</b>	<i>Icom IC-R2 Portable Scanner</i>	
<i>The Prosat DVB Digital Receiver</i>		<b>Ask Bob</b> .....	<b>94</b>
<b>Beginner's Corner</b> .....	<b>68</b>	<i>Solutions for the Technically Adept</i>	
<i>Great Radio Reads</i>		<b>Review</b> .....	<b>96</b>
<b>View from Above</b> .....	<b>70</b>	<i>AVCOM SDM42A Spectrum Display</i>	
<i>Scanning the Weather Satellites</i>		<b>What's New</b> .....	<b>97</b>
<b>The Fed Files</b> .....	<b>72</b>	<b>Stock Exchange</b> .....	<b>102</b>
<i>The Nat'l Disaster Medical System</i>		<b>Advertisers Index</b> .....	<b>102</b>
<b>Plane Talk</b> .....	<b>74</b>	<b>Closing Comments</b> .....	<b>104</b>
<i>ATCC: It's No Game!</i>		<i>Radio Waves and the Human Body</i>	

**EDITORIAL STAFF**

Correspondence to columnists may be mailed c/o *Monitoring Times*; any request for a reply should include an SASE.

Frequency Manager .....	Gayle Van Horn .....	gayle@grove.net
Frequency Monitors .....	David Datko, Mark J. Fine	
Program Manager .....	Jim Frimmel .....	frimmel@star-telegram.com
American Bandscan .....	Doug Smith, W9WI .....	w9wi@bellsouth.net
And More! .....	Jock Elliott KB2GOM .....	lightkeeper@sprintmail.com
Antenna Topics .....	W. Clem Small, KR6A .....	clemsmal@bitterroot.net
Beginner's Corner .....	T.J. Arey, WB2GHA .....	tjarey@home.com
Below 500 kHz .....	Kevin Carey, WB2QMY .....	lowband@gateway.net
Computers and Radio .....	John Catalano .....	j_catalano@conknet.com
Digital Digest .....	Stan Scalsky .....	sscalsk@mail.ameritel.net
	Mike Chace .....	michace@dtus.com
Experimenter's Wkshp .....	Bill Cheek .....	bcheek@cts.com
Federal File .....	Larry Van Horn, N5FPW .....	larry@grove-ent.com
K.I.S. Radio .....	Richard Arland, K7SZ .....	k7sz@juno.net
Magne Tests .....	Lawrence Magne	
Milcom .....	Larry Van Horn N5FPW .....	larry@grove-ent.com
On the Ham Bands .....	Ike Kerschner, N3IK .....	N3IK@hotmail.com
Outer Limits .....	George Zeller .....	George.Zeller@aclink.com
PCS Front Line .....	Dan Veeneman .....	dan@decode.com
Plane Talk .....	Jean Baker, KIN9DD .....	jeanandbob@erols.com
Programming Spotlight .....	John Figliozi, KC2BPU .....	jfiglio1@nycap.rr.com
Propagation .....	Jacques d'Avignon .....	monitor@rac.ca
QSL Corner .....	Gayle Van Horn .....	gayle@grove.net
Satellite Radio Guide .....	Robert Smathers .....	roberts@nmia.com
Scanning Equipment .....	Bob Parnass, AJ9S	
Scanning Report .....	Richard Barnett .....	ScanMaster@aol.com
SW Broadcasting .....	Glenn Hauser .....	ghauser@hotmail.com
SW Broadcast Logs .....	Gayle Van Horn .....	gayle@grove.net
The Launching Pad .....	Ken Reitz, KS4ZR .....	ks4zr@firstva.com
Utility World .....	Hugh Stegman, NV6H .....	driver8@netcom.com
View from Above .....	Lawrence Harris .....	Lawrence@itchycoo-park.freemove.co.uk
Washington Whispers .....	Fred Maia, W5YI .....	fmaia@cwixmail.com



# "Privacy" Bill Resurrected as HR 514

A Special Report by Rachel Baughn, editor

The House of Representatives, anxious to show some accomplishments in the 106th Congress, has posted a number of "non-controversial" bills for quick action. One such bill is HR 514, introduced by Congresswoman Heather Wilson of the House Subcommittee on Telecommunications, Trade and Consumer Protection. The bill is identical to the final form of HR 2369, which passed the House last session with only one opposing vote.

HR 514 passed the House with equal ease in February. The only hope radio hobbyists have of resisting the bill is when it is referred to the Senate Commerce Committee, which last year did not act on it.

What's wrong with HR 514? Isn't this the version that several hobby spokesmen have called "the best we could hope for?"

While HR 514 is immensely improved from HR 2369 as Rep. Tauzin originally introduced it, there are two objections to it: (1) It is redundant legislation — duplicating, on almost every point, already existing regulations in the US Code, and (2) in its eagerness to close all potential loopholes, the bill may also close the door to any future for scanning in a digital world. Its troubling and contradictory requirements could come to haunt radio hobbyists, manufacturers, and even the Federal Communications Commission, which is tasked with carrying out the bill's mandate.

## Is "More" Always Better?

Let's take the redundancy issue first. Although the U.S. Code is fragmented and complicated, that doesn't mean it is improved by adding more legislation on top of it. The issues the bill was designed to address — equipment modification, eavesdropping on phone calls or paging services, and divulgence of such intercepted communications — are already well covered by existing law, found in three primary locations: Title 47 US Code Section 302; Title 47 US Code Section 605; and Title 18 Part I Chapter 119. In spite of this, HR 514 seeks to duplicate or unnecessarily complicate these existing laws.

The perception that such legislation is needed may arise in part because enforcement of existing restrictions (such as publication of the content of cellphone conversations) has been rare or extremely selective. However, in response to pressure from a number of sources, this is changing. Also, the Federal Communications Administration (FCC) has been prompt in posting clarifications and fact sheets to the public via the Internet when it is evident that there is confusion in interpretation of regulations.

HR 514 adds substantial text to the language regulating scanning receivers — the only radio equipment singled out for such micromanagement by Congress. It does help bring several existing restrictions together in one place, but it reinforces a misguided approach to privacy enhancement. It forbids specific technology and frequency ranges, rather than allowing the industry to devise ways to avoid reception of the protected communications — a task it has proven it can do.

And that brings us to the second objection — the threat to future product development.

## Equipment Authorization

HR 514 instructs the FCC to deny equipment authorization to any scanning receiver that is capable of receiving, or of being readily altered to receive, frequencies allocated to the domestic cellular or personal communications services. Nor can the receiver be easily equipped with digital decoders for cellular radio telecommunications, personal communications, protected specialized mobile radio services, protected paging services, and any encrypted radio transmission. (*Protected* is defined as "secured by an electronic method that is not published or disclosed except to authorized users.")

On the other hand, the bill says in regard to privacy protection for shared frequencies: "The Commission shall, with respect to scanning receivers capable of receiving transmissions in frequencies that are used by commercial mobile services and that are shared by public safety users, examine methods, and may prescribe such regulations as may be necessary, to enhance the privacy of users of such frequencies."

This is an acknowledgment of the fact that Chapter 119 allows the public to listen to unscrambled public safety agency communication (along with a substantial number of other allowed services). Today, however, a great number of public safety agencies share frequencies with or lease space from commercial mobile services which interface with a variety of protected telecommunications services. These agencies share both frequencies and technology with services that are protected under this bill — and such sharing can only be expected to increase in the future.

If scanners are denied access to shared frequencies and to the technology, they are denied their future. New criteria for spectrum conservation and flexibility mandate that the future will be digital. It has largely been assumed that the APCO 25 standard being promoted by public safety advocates will use a digital stan-



dard, but one that will be available to the public so that compatible scanners may also be designed.

But public safety agencies aren't waiting for APCO-25-compliant radios to be developed by (for example) Motorola: they are signing on with Motorola's proprietary digital systems ... and with Nextel, or whoever promises to deliver whatever is top priority for the client. For some agencies top priority is cost; for others — though they may not admit it publicly — it is shutting out the criminals, the media, and the public.

Although today's trunk tracking scanners have managed to develop nonproprietary technology to follow public safety agencies using analog trunked systems, this bill would prohibit development of such technology if the agencies were to move to a proprietary digital system. APCO 25 may be too little, too late, if it arrives at all.

There is one ray of hope in the wording. Scanner manufacturers might have the freedom to develop a decoder to receive digital public safety communications due to the fact that specialized mobile radio frequencies are not declared off limits; if the receiver is allowed to decode the data channel to enable receiver control, conversations on private services are not being decoded.

It's the FCC which is handed the gnarly task of determining how to allow access to public safety communications while protecting the privacy of commercial mobile services. If it comes to a choice between public access and big business, this House bill leaves no doubt as to which way the decision will go.

For a full text of HR 514 and how existing legislation would read with the new text, see our website at [www.grove-ent.com/hmpgmt.html](http://www.grove-ent.com/hmpgmt.html).

"Privacy" Bill, continued on page 101



By Fred Maia, W5YI  
fmaia@cwixmail.com

# FCC Proposes Low Power Radio Broadcast Service

## Pirates may be ineligible unless "rehabilitated"

At a January 28 public meeting, the Federal Communications Commission took the first step toward creating relatively low cost community "alternative voice" radio stations. It proposed to introduce Low Power FM (LPFM) broadcasting which has not been available since 1978. The proposal launches the FCC itself into what is likely to be tremendous controversy and a predicted "land rush."

The text of the 64-page Notice of Proposed Rulemaking (NPRM) in Mass Media (MM) Docket 9925, is posted in text version without footnotes at [http://www.fcc.gov/Bureaus/Mass\\_Media/Notices/1999/fcc99006.txt](http://www.fcc.gov/Bureaus/Mass_Media/Notices/1999/fcc99006.txt) or in its entirety in Word Perfect version at .../fcc99006.wp. Public comments are invited on or before April 12, 1999, and reply comments on or before May 12, 1999.

The Notice proposes to create new 1000 Watt (LP1000) and 100 Watt (LP100) FM stations, and to reduce rules regulating FM stations on adjacent frequencies. With an antenna height of 60 meters, LP1000 stations could serve an 8.8 mile radius, the FCC said, while LP100 stations could serve 3.5 miles from 30 meter height.

The NPRM comes after the Commission received several petitions to create LPFM services, as well as some 13,000 inquiries last year from persons wanting to start low power stations. Last year also saw intense activity by "pirate" unlicensed "micro radio" stations. Former pirates who refused to shut down their stations may not have access to LPFM licenses unless the pirates could demonstrate that they had "rehabilitated" themselves. But "we did not slam the door on those people," said Mass Media Bureau chief Roy Stewart.

The NPRM covers many LPRM issues including:

**Status.** LP1000 stations would be primary on the frequency, while LP100 stations would be secondary and must accept any interference they may receive.

**Type of station.** Should LPFM stations be commercial, noncommercial, or both?

**Ownership.** Existing broadcasters could not own or have any marketing agreements with a LPFM station. No one could own more than one LPFM station in the same community.

**Electronic filing.** The FCC proposed that license applications be filed electronically.

**Filing windows.** Short "windows" of only a

few days would limit the applications, but the FCC asked for comment on longer windows or a first-come procedure.

**Auctions.** More than one applicant for an available frequency would have to be resolved by auctions, but the FCC asked for comment on other means. Implications are that lotteries, not auctions would be used to resolve multiple *noncommercial* applications.

To clarify: The FCC did not propose to create micro radio stations (110 W); it is only accepting *comments* on micro radio. (This matter caused amusing confusion at the FCC LPFM press conference: Roy Stewart told reporters that the FCC is proposing micro radio, while FCC engineer Keith Larson repeatedly indicated that the FCC was *not* proposing such stations.)

Groups representing noncommercial and micro radio interests cautiously praised the proposal, while the National Association of Broadcasters (NAB) fumed that LPFM would "devastate" the FM band. NAB warned that LPFM could harm the "inband onchannel" (IBOC) approach to digital radio adopted in the US.

### The Chairman Speaks

At the FCC, LPFM is largely a campaign of Chairman William Kennard, whose passionate speech at the public meeting provided much insight into his motivation for pushing low power radio and bucking incumbent broadcasters.

Mr. Kennard said, "We all know that as more and more stations become concentrated in fewer and fewer hands, there are fewer opportunities for people who want to use the airwaves to speak to their communities.

"Questions have been raised in this proceeding already about interference. Will we create a class of new low power stations that will wreak havoc in the FM band? Of course we won't do that. This agency is the guardian of the spectrum ... But I believe that this agency has always been at its best, has had its shining moments, when it has authorized new services for the public, often over the vehement objections of incumbents.

"We did that with cable television. We did that with direct broadcast satellites. We did that with the digital audio radio service. We did that with low power television.

"And that's what LPFM promises to do. We will be mindful of interference concerns. We will be mindful of the need to ensure that the broadcast industry has opportunities to convert to digital.

"So, today I want to challenge the existing broadcasters to work with us, to find ways that we can have a low power radio service that coexists with the incumbent services. So that we can work together to maximize the use of the public's airwaves for the benefit of all Americans."

Chairman Kennard also asked the industry not to use "interference concerns as a smoke screen for other matters," meaning a fear of greater competition.

### Key concerns and a dissenting opinion

Commissioner Susan Ness said that three issues will be in the forefront in LPFM:

- (1.) Whether LPFM should be open only to noncommercial entities;
- (2.) Whether LPFM would affect IBOC; and
- (3.) Whether LPFM would create undue interference to full power stations.

FCC Commissioner Harold Furchtgott-Roth had already voted NO on the NPRM. The FCC later released his opposing statement, which contains some interesting key points:

- Very few new stations could be licensed in major urban markets even if the second and third adjacent channel protections were completely dropped. New York City could have no LP1000 stations or LP100 stations.

- LPFM is supposed to help minorities and women, but there is no way to ensure that they get the licenses.

- The FCC proposed to impose strict ownership restrictions on LPFM, but Congress removed such limits in the Telecommunications Act of 1996. Some believe consolidation of radio ownership is bad, but Congress made it the law.

- Instead of LPFM, people could buy existing stations, buy air time on the stations, or communicate via "...amateur radio, email, Internet home pages, bulletins and flyers."

- LPFM enforcement will be a drain on the FCC and will require it to micromanage even the smallest stations.

*Washington Whispers,  
continued on page 102*



# Now You Can Get The Most Out Of Your TV/FM. SCANNER. OR HAM RADIO SET!

## NIL-JON Antennas™

**STRONGER, MORE COMPACT ... SUPERIOR CALCULATED PERFORMANCE ... NO TUNING NECESSARY**

*Highly acclaimed in MT's "Scanning Report" column by Richard Barnett in last month's issue!*

Makes use of UNIQUE FORMULAS where EXTENSIVE MATHEMATICS derives element length & spacing for best gain/pattern/impedance/SWR/bandwidth, taking into account interaction between EVERY component of the final product: (EVERY ELEMENT affecting EVERY OTHER ELEMENT), reflector, driven element, directors, yagi-to-yagi effect, end mount mast effect, & the hardware of the antenna down to the mounting plate.

A "FERROMATCH SYSTEM" (no lossy gamma match!), but a straight forward method of tackling (reducing TV I, RFI) the 'down-the-outside-of-the-shield' RF problem with an unbalanced feed to a balanced driven element utilizing newer ferrite technology & materials. NO PERFORMANCE ALTERING END CAPS! ... Instead, maintain optimum calculated performance ...*No end capacitance effect & no 'skin effect'.*

EVERY ANTENNA PRETUNED! We have FACTORY OPTIMIZED performance and match leaving you time to concentrate on implementing a good support structure & enjoying MAXIMUM PERFORMANCE. HIGHEST GAIN-FOR-SIZE allowing use of large bandwidth & extra sturdy materials without excess weight. The NIL-JON clearly outperforms other brands in thorough test analysis.

NJA uses high strength aluminum, polycarbonate & stainless steel fasteners for long life & durability.

NJA is MORE COMPACT (relative to performance) making it easier to install (in more locations), less vulnerable to wind damage, easier on your rotor, & less unsightly than bulkier antennas.

Each NJA is manufactured to precise standards in our modern OHIO FACILITY with unexcelled attention to detail.

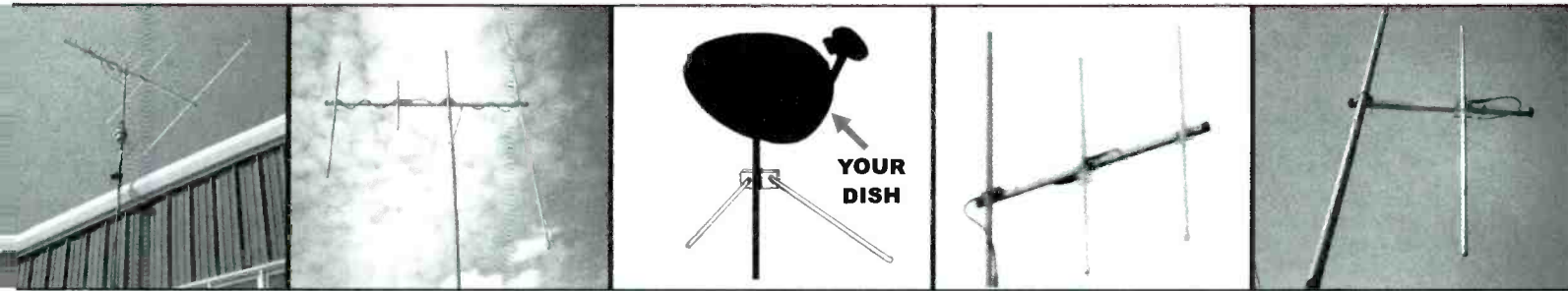

**HD-TV-VHF/UHF/FM-F**

**HD-SCANNER-WB-OMNI-F**

**HD-TV/FM-S.OMNI-F**

**HD-146-V3-U**

**HD-6M or 10M-WB-OMNI-U**

CATEGORY/MODEL	FREQ/COV(*)	DESCRIPTION	CONN.	dB GAIN	DIMENSIONS BOOM LG EL	WEIGHT (LBS)	WINDLOAD (SQ FT.)	POWER RATING	SHIPPING WEIGHT
<b>BROADCAST TV/FM — SCANNER</b>									
HD-TV-VHF/UHF/FM-F	TV CHNL'S 2-69 FM-Stereo	Compact, Long Range, Full Coverage TV VHF/UHF/FM The ultimate antenna for the new digital high definition Television (HDTV) Broadcast. VHF low 10dB, HI 12dB. UHF 21dB	F	(**)	88" 108"	7.5	1.5	N/A	12.5 LBS.
HD-SCANNER-WB-OMNI-F	25-1300 MHZ	Long Range, <b>Continuous Coverage</b> Top or Side ### Mount to Mast/Tower ### no add'l hardware needed (Still Omnidirectional)	F	(**) 6.2 dB	67" 90"	7.5	1.9	N/A	12.5 LBS.
HD-TV/FM-S.OMNI-F	TV CHNL'S 2-69 FM-Stereo	Unique 'Steerable Omnidirectional' Mount Almost Anywhere onto Wall or Mast (***) On/In Rooftop/Attic/Existing Satellite Dish Mast Mount/Side of House/Closet/Etc.!	F	Unity (**) 5.2 dB	N/A 30" [ant. 19"(h) x 40"(w) x 3"(d)]	1.0	0.2	N/A	3.0 LBS.
<b>HAM-VHF YAGI</b>									
HD-146-V3-U	142-150 MHZ	End Mnt. 3 ele. Vert. using mast/tower for reflector Detailed, easy to follow, stacking instructions included for even higher gain!	U	12 (15 dB if stacked!)	36" 36"	3.5	0.4	600 W	6.5 LBS.
<b>HAM-WB-OMNI VERTICALS — SIDE ARM MOUNT WITH HARDWARE INCLUDED</b>									
HD-10M-WB-OMNI-U	26.9-30 MHZ	Top or side mount, S.M.I.A. (##). 3.1 (HAM) dB; 10.6 ("CB LINGO") dB	U	(#)	72" 204"	5.5	1.6	1000 W	10.5 LBS.
HD-6M-WB-OMNI-U	50.0-54 MHZ	Top or side mount, S.M.I.A. (##)	U	(#) 3.1 dB	42" 108"	3.5	0.9	1000 W	8.5 LBS.

**OHIO**  
(7% SALES TAX INCLUDED)

**OUTSIDE OHIO**

**\$279.95 \$298.14**

**\$154.95 \$165.75**

**\$93.95 \$99.47**

**\$24.95 \$26.35**

**\$134.95 \$143.35**

**\$149.95 \$160.45**

**\$134.95 \$143.35**

**HD-TV/FM-S.OMNI-F CLAMP KIT**

Prices include S&H in Continental U.S.



Dealer Inquiries Welcome

NOTES: (\*) For Ham antennas, usable frequency range transmitting with an SWR of 1.5:1 or less, typically less than 1.2:1. Frequency Range shown is usable without retuning the antenna. No tuning is required for any Nil-Jon Antenna: just assemble and install using the guidelines in your instruction manual.  
(\*\*) With TV/FM and Scanner Antennas, most manufacturers are very vague about what to expect for performance or gain, and gain figures given seemed quite high for results obtained. All competitive models tested were below Nil-Jon's performance. Even several different manufacturers' largest TV antenna models (close to three times our size) (including one model that claims a 200 mile range!), fell short on an overall total performance basis, of the consistent performance obtained from the Nil-Jon's Compact 7'4" TV model! Nominal gain figures are shown for our antennas.  
(\*\*\*) With optional Mast Clamp Kit  
(#) Other antenna companies claimed gain figures which seemed quite high for the results obtained, and the Nil-Jon Antennas substantially out performed them. Nominal gain figures are shown for our antennas.  
(##) S.M.I.A. means Support Mast Interaction Adjusted. Every Nil-Jon Antenna uses calculations for the interaction of other objects, such as your own mast.

ABBREVIATIONS: dB=Decibal, F="F" Connector, HD=Heavy Duty as in High Strength & Performance, not weight, LBS.=Pounds, LG-EL=Longest Element, M=Meter, MHZ=Megahertz, U=SO-239 "UHF" Connector, V=Vertical, WB=Wide-Band, SQ. FT.=Square Feet (Windload includes boom, where applicable)

**TO ORDER:** Check or M.O.: Make out to 'Nil-Jon' & send to Nil-Jon Antennas, 29462 Lorain Rd., N. Olmsted, OH 44070 [state model(s) on memo of check/M.O.]  
Credit Card: Call 440-777-9460 with M.C./Visa/Discover/American Express Acct. #

# NIL-JON Antennas

TM

(440) 777-9460 Fax (440) 777-9657

Website: [www.Nil-jonant.com](http://www.Nil-jonant.com)

Email: [Nil-jonant@juno.com](mailto:Nil-jonant@juno.com)

[www.americanradiohistory.com](http://www.americanradiohistory.com)

## Dissenting Voices

Although public opinion expressed in the newscippings forwarded to *MT* have all seemed favorable to the Federal Communications Commission (FCC) proposal for low-power FM stations (see page 4) it should surprise no one that the Notice of Proposed Rulemaking should have at least two vocal opponents: the National Association of Broadcasters and Rep. Billy Tauzin (original sponsor of the "privacy" bill now known as HR 514).

Rep. Tauzin said in a letter to FCC Chairman Bill Kennard, "The policy, political, economic and budgetary ramifications of this undertaking are potentially staggering." Tauzin and the NAB have both cited a "devastating" proposal for interference. Kennard maintains that "the radio airwaves are big enough for all of us."

Most of the news stories make the point that since restrictions were eased in the Telecommunications Act of 1996 (a move intended to increase competition), independent stations have been taken over by conglomerates and "the programming has grown more formulaic, narrow and dull." Local and minority ownership and news have decreased.

FCC Commissioner Harold Furchtgott-Roth cast the one dissenting vote against the NPRM, stating that, although some think consolidation of radio ownership is bad, Congress made it the law. He also recently argued against the 20% increase in the FCC's budget proposed by President Clinton, saying "The purpose of the 1996 law was to foster competition and reduce regulation. ... That shouldn't require a larger budget."

Some say such competition is just what the NAB is afraid of. So far, Kennard is standing firm; he told an NAB conference last year, "We cannot deny opportunities to those who want to use the airwaves to speak to their communities simply because it might be inconvenient to those of you who already have these opportunities."

## Amateurs Mourn Hussein

Radio amateurs around the world mourned the death of Jordan's King Hussein, JY1, on Feb. 7th. The Middle East's longest-reigning ruler, he'd been Jordan's king for 47 years, taking the throne when he was just a teenager.

Hussein was a life member of the American Radio Relay League, which valued his support

in obtaining new amateur bands at the 1979 World Administrative Radio Conference. Hussein regarded his 1983 contact with Owen Garriott, W5LFL, on board the Space Shuttle *Columbia*, as a high point in his Amateur Radio activity. He also participated in the historic 1995 joint Israel-Jordan JY74X operation on Mt Nebo.

Hussein's friend Bruce "Blackie" Blackburn, W4TA/JY9BB, of St Petersburg, Florida, called him "one of the world's most respected amateurs." "He was a wonderful guy, interested in everything and everyone," he said. He insisted on being addressed merely as Hussein on the air. *MT*'s assistant editor Larry Van Horn experienced the same informality in an unforgettable contact with JY1 in the 1970s.

All members of the Jordanian royal family automatically have Amateur Radio privileges in Jordan.

## Experimental 5-MHz License

The FCC has issued an Experimental Radio Service license to the ARRL to permit two-way tests in the vicinity of 5 MHz, the most likely site of the next amateur HF band. The license, call sign WA2XSY, was issued to a group of 15 amateurs. They will conduct experimental, two-way RTTY and SSB transmissions within the band 5.100 to 5.450 MHz.

"The idea is to show that an amateur allocation there will improve our emergency communication capabilities by filling the gap between the 3.5 and 7.0 MHz bands," said ARRL Executive Vice President David Sumner, K1ZZ. Sumner pointed out that several of the participants are phone net members in the Caribbean and Gulf area who frequently handle hurricane-related traffic and now must alternate between 75 meters and 40 meters. Other participants are members of a nationwide digital data-forwarding network.

Participants in the WA2XSY experiment may run up to 200 W effective radiated power. Multiband trap dipoles capable of operation on 80 and 40 meters as well as at 5 MHz will be employed at each station location. Operation by participants will consist of short transmissions to determine propagation characteristics.

## Bombarded by Radio

Although a few companies, such as Skandia Insurance Company in Sweden, have officially recognized that some people are "electrically sensitive," you can carry this sensitivity thing too far ... One of our readers regularly submits stories from a section of his paper called "News of the Weird." Here's one for April:

The story, which originated in the *Philadelphia Inquirer*, concerns an unnamed man who was refused a gun-carry permit. He had told a panel of the Philadelphia Dept of Licenses and Inspections that he need the gun to protect himself from "dwarf drug dealers" who were



### April 9,19: Marietta, GA

Southeastern VHF Society (SVHFS) technical conference; Marriott Hotel in Windy Hill, Marietta, GA. Presentation of papers, antenna gain and noise figure measurements; Discussion of EME, MS, FAI, E-skip and other topics on operation above 50 MHz. Contact Bob Lear, PO Box 1269, Dahlonga, GA 30533, [k4sz@stc.net](mailto:k4sz@stc.net)

### April 10, May 1: St Louis County, Missouri

All-day training Severe Weather Observation seminars. SKYWARN level 1 in a.m., Level 2 in p.m. New class on Severe Weather Safety evening of April 14. For locations and information call 314-889-2857 for taped message. Classes open to anyone at no cost.

### April 16-18: Doolittle Raiders Special Event Station

Stu Rockafellow ARS of Plymouth, MI, on the air from USAF museum in Dayton, OH, with 31 original members of Jimmy Doolittle Raid to commemorate 57th anniversary of their WWII mission. SSB 7270, 10116, 14270, 28370 kHz, 144.215 MHz. Op during museum hours 1300 UTC on 16th to 1600 UTC 18th. For info or QSL contact Dave Langston, KB8RAP, 1000 Town Center, Suite 1200, Southfield, MI 48075; (248) 948-42437.

### April 23-24: Little Rock, AR

Little Rock Hamfest at the Little Rock Expo Center; exhibitors, tail-gating, forums, special exhibits, working stations, contests. Contact Jim Blackmon, K5VZ, (870) 246-7833; <http://www.aristotle.net/~ares/lrh99.html>

### April 25: Fishkill, NY

Mt. Beacon ARC Bi-Annual Hamfest. Location: John Jay High School, Fishkill, NY. Contact Ken Akasofu, KL7JQC, (914) 485-9617, [KL7JQC@iname.com](mailto:KL7JQC@iname.com). Talk-in on 146.97 MHz. Check web site at <http://www.mhv.net/~fritzing> General admission at 8a.m. \$5.00/Family. ARRL forums, flea-market, FCC license exams (walk-ins accepted)

### May 1: Cedarburg, WI

21st annual Cedarburg Swapfest at the Circle-B Recreation Center, Hwy 60 & County I; talk-in 146.37/97 and 146.52. 8a.m. to 1p.m.; admission \$4. SASE to Joe Holly, 1702 Holly Lane, Grafton, WI 53024, 414-377-2137.

### May 2: Hagerstown, PA

The Great Hagerstown Hamfest, sponsored by the Antietam Radio Assoc, at the Hagerstown Community College Athletic and Recreation Building. Contact Tina Jones KB8ZQM, (304) 728-7769, [kb8zqm@intrepid.net](mailto:kb8zqm@intrepid.net); [www.erols.com/rjlong61/ara](http://www.erols.com/rjlong61/ara). Talk-in 147.090+; 8a.m.-3p.m., \$5 adm.



"beaming radio waves" onto him by satellite and reading his mind. His lawyer argued there was no evidence introduced before the panel that his client was not of sound mind.

Apparently the man had had an earlier permit revoked when he showed up at a hospital with his head wrapped in tin foil because he was experiencing pain from radio waves.

**Cellular radiation**

In 1997, a Swiss magazine (*Ktip*) investigative article compared the radio frequency (RF) radiation from the antenna of 16 cellular handsets, and concluded that style was more important to manufacturers than safety. In fact, several of the antenna developers said they did not even own equipment to measure the radiation. The magazine acknowledged that all units were within the required limit of 2 watts per kilogram, but said that they varied widely. Those which fared best seemed to use longer antennas directed away from the head and used the body of the cellphone as a shield.

We recently heard of a device called RangeStar, claiming to boost the signal of PCS phones (1850-1990 MHz) by 100 percent while reducing radiation to the head by 50 percent. Call 877-966-3712 or visit their website at [www.rangestar.com](http://www.rangestar.com). Tell them to work on a cellphone version!

**The Appeal of Pursuits**

"There is a market for everything," said the journalist at the *LA Times* who reported somewhat derisively on a paging service launched on the Internet by Ken Kuwahara, a Los Angeles-area police officer. For an introductory fee of \$1 a year for a basic membership in PursuitWatch, Kuwahara will make sure you know about every cop pursuit shown live on local TV (about one a week).

The article said that local stations report a jump in ratings whenever regular programming is preempted to show a chase. Why? It's the same reason listening to the scanner is so popular. As KTVK-3 (Phoenix, AZ) news director Dennis O'Neill, puts it, "There's something about watching news happen live."

According to *The Arizona Republic*, police in Phoenix had chastised the media for getting in closer than the police copters, who hang back so suspects won't know they're being followed. But a recent incident forced a grudging compliment from Sgt. Dave Trombi. "These guys are real experienced pilots. A lot of times the media helicopters are instrumental in search-and-rescue-type scenarios."

Sgt. Trombi, like many Phoenix residents, had been watching Bruce Haffner, pilot of a KTVK news helicopter, follow a van through rush hour traffic. According to Haffner's on-air account (barely acknowledged by the newspapers or police) he had been listening to his scanner when he became aware that a chase was

taking place on the highway below him. At one point, law enforcement officers apparently lost the vehicle, which was weaving in and out of traffic, pulling U-turns and driving the wrong way. Police policy, especially during rush hour, is to keep well back to avoid escalating the chase and endangering lives.

Bruce was able to locate the vehicle and, keeping far enough above and behind the vehicle that he hoped it would not realize it had been spotted, notified the police that he had the vehicle in sight.

The two men were suspected of robbing a dry-cleaners and fleeing in a stolen vehicle. After a 10-mile chase, (police were eventually able to position a helicopter with Haffner's guidance) they were arrested in Tempe.

Take a bow, Bruce. Some of the wording in HR 514 is specifically targeted at the media. But if it restricts their access to the activities of our public servants, we'll all be the losers.

**The Trouble with Towers**

When is a public utility not a public utility? Answer: when it's a commercial cellular or PCS provider. Although Congress has extended many protections and perks to these new systems, they have not allowed them to totally over-rule local zoning ordinances. The FCC and federal courts are both working to force local administrations and wireless communications carriers to work together. It is "one of the most contentious issues I have faced as the chairman of the FCC," William Kennard has said.

Local efforts have forced a few towers to be dismantled for failing to receive proper authorization (Palm Beach County, FL), or for failing to follow zoning restrictions (near Victoria, British Columbia), or have received a stay on further construction until issues are resolved.



Although the Telecom Act of '96 disallowed health concerns as grounds for denying a tower construction permit, it does say the company must work with local zoning agencies to find a mutually-agreeable site. The Virginia 4th Court of Appeals upheld this local authority in a ruling which was summarized as follows by one of the attorneys:

The decision, issued in a case involving the City of Virginia Beach and AT&T Wireless PCS and several other wireless providers, concludes: (1) cities need not issue detailed written decisions in order to support a decision to deny construction of a tower; (2) a decision to deny a request for permission to construct a tower can be based on the complaints of ordinary citizens that the tower will damage the neighborhood; (3) denial of a tower siting request is not inherently discriminatory; and (4) provisions of the Telecommunications Act which state that a city may not enact laws prohibiting the provision of cellular services do not prevent a city from denying individual applications for approval of a siting request.

As is always the case when battling big business or powerful lobby groups, local citizens have found it useful to organize and to share information. The Internet makes that easier than ever before. If you want to know what your community can do, two sites will get you started: Cellular Tower Coalition at [www.cellulartower.com/](http://www.cellulartower.com/) and F.A.C.T.S. (Families for Appropriate Cell Tower Siting) at <http://Uranus.flipag.net/nopoles/>

"Communications" is written by Rachel Baughn, from clippings provided by our readers: Anonymous, New York; Harry Baughn, NC; Chet Copeland, VA; Ken Dupuis, NY; Leslie Edwards, PA; Jim Frimmel, TX; Dale Newton, VT; Doug Robertson, A; Brian Rogers, MI; Ed Schwartz, IL; Richard Sklar, WA; Larry Van Horn, NC.

SEE US ON THE WEB!  
[www.vikingint.com](http://www.vikingint.com)

**Rave Review**  
Pop Comm  
April '96

**Professional 10 HOUR RECORDER**  
"BUILT LIKE A BATTLESHIP"

**SPECIAL**  
Monitoring  
Times Price...

- Heavy duty commercial recorder - NOT improvised from consumer models
- 12, 14, and 16 hour models also available
- BUILT-IN voice activation (add \$30)
- Applications information included
- Dimensions: 11.5 x 7.0 x 2.75"

**FREE**  
UP TO \$100  
OFF (LIMITED  
OFFER)

**\$159**

COD's OK. Calif. residents add tax. Sorry, no credit cards. Free catalog USA only, other countries \$5. Free shipping to 48 contiguous states on ground orders.

**Viking International** 150 Executive Park Blvd. #4600 San Francisco, CA 94134  
Factory Direct Phone: (415) 468-2066 • Fax: (415) 468-2067 "Since 1971"

# The Random Length Wire Antenna

By Joseph J. Carr, K4IPV

If you look in the owner's manual of almost any high frequency shortwave receiver you will find instructions on how to build a random length wire antenna. "Improves performance" we are fond of saying. Antenna books, such as my *Receiving Antenna Handbook*, almost always discuss this type of antenna. But how well does this antenna perform? Let's take a look.

## The Antenna

The random length wire antenna is of the general class called Marconi antennas. These antennas are unbalanced with respect to ground. Figure 1 shows the antenna studied for this article. It consists of 100-feet of #14 AWG copper wire. The receiver end of the antenna is 10 feet off the ground, while the far end of the antenna is 30-feet off the ground. These dimensions were chosen because they represent a "typical" form of an-

tenna used by many shortwave listeners.

This antenna has a quarter wavelength resonant frequency close to 5 MHz. The "standard wisdom" would say 4.68 MHz, but the actual figure depends on a number of factors that are hard to predict.

## Modeling Software

One way to evaluate antennas without owning a multi-million dollar antenna instrumentation range is to use antenna modeling and simulation software. I used Nec-WIN Basic for this project. Nec-Win Basic is based on the NEC engine, which is a big brother of the public domain mini-NEC 3 that you can download from various Internet sites.<sup>1</sup>

The software will perform the numerical electromagnetic calculations needed to determine the antenna pattern, and then will plot them in graphical form (if requested to

do so). It will also calculate the gain over isotropic for each individual angle around the compass.

## Gain over Isotropic?

The isotropic gain of an antenna is a theoretical construct that compares the gain of a real antenna with the signal level that would be produced by a perfectly spherical point source radiator. The isotropic gain is taken to be 0 decibels (dB). The gain of the antenna under consideration is then compared with the 0 dB isotropic radiator, and is expressed in dB (usually labelled "dBi" to indicate that decibels over isotropic is used). A half wavelength dipole, for example, has a gain about 2.1 dBi (i.e. above isotropic). This method of measuring gain is a handy way by which antenna engineers characterize and compare antennas.

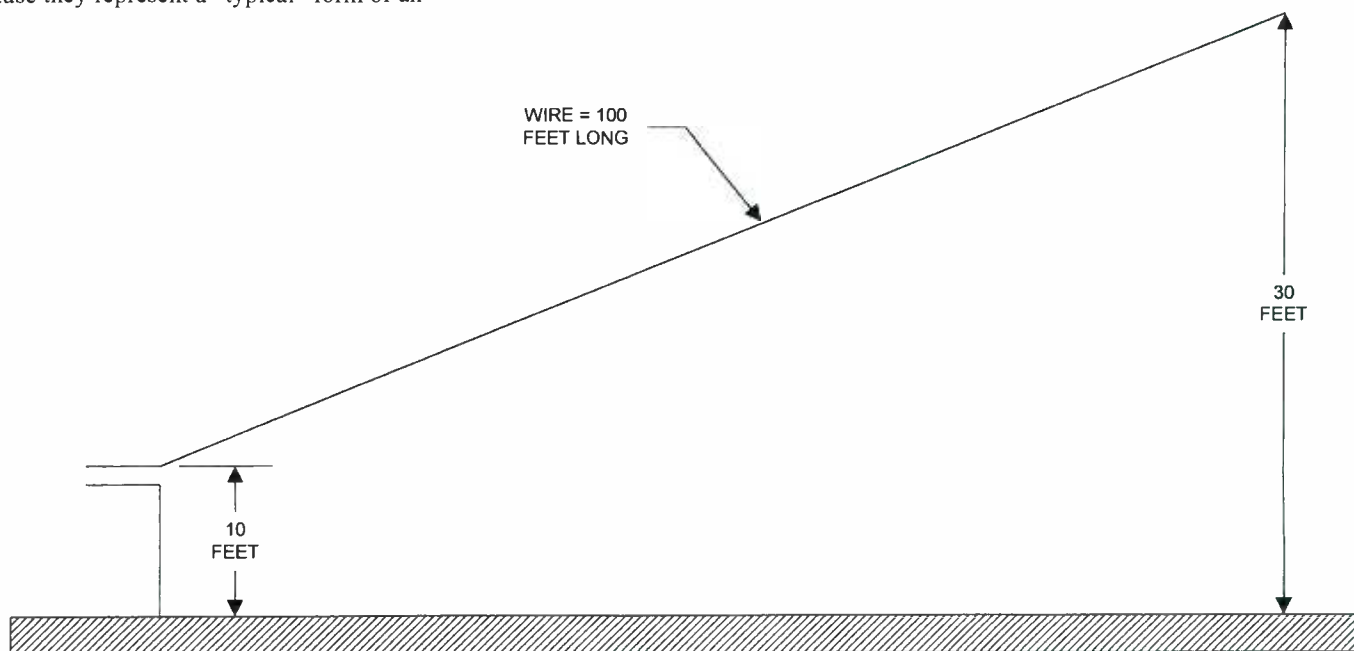

FIG. 1 - A "standard" 100-foot Marconi antenna.



## Model Set-Up

The antenna's physical parameters were entered into the modeling program. The Nec-WIN software allows various types of ground to be selected. I selected "rolling hills, rich soil" as the standard ground for this study. There were other selections, and some of them might be more typical of the ground in your area, but I felt that this selection was reasonable for a large percentage of readers.

One of the possible ground selections is the "perfect" ground, and that is the default value. But it is also somewhat meaningless because the nature of the ground can seriously affect antenna performance.

Once the parameters were entered the calculations were performed at 3 MHz, 5 MHz, 7 MHz, 9 MHz, 11 MHz, 15 MHz, 20 MHz and 25 MHz. The 3 MHz frequency is below the quarter wavelength resonance point, while the 5 MHz frequency is close to, or at, the resonant point. All other frequencies are above the resonant point. According to standard wisdom, these antennas work best at the quarter wavelength resonant frequency and higher.

A VHF frequency (160 MHz) was also examined. The reason will surprise many

readers. At VHF, an HF random length wire will work as a long wire with many wavelengths of radiator. This fact makes the antenna provide gain that exceeds the gain at HF by a considerable amount. Impedance matching is sometimes a bit tricky, but at some frequencies it is easily done.

I first saw the use of HF antennas on VHF in the early 1960s when I was using a ham station owned by a club. There were two antennas, a 75-meter half wavelength dipole, and a 14-element VHF Yagi. I accidentally connected the wrong antenna to a 2-meter (144-148 MHz) ham transmitter. The transmitter loaded up (meaning the impedance was within range) and signal reports were favorably compared with the Yagi.

In addition to the pattern, the following results parameters were tabulated: gain (dBi), beamwidth (degrees) and front-to-back ratio (dB).

The gain will give you a relative idea of

FREQUENCY	GAIN (dB)	BEAMWIDTH (Deg.)	F/B RATIO (dB)
3 MHz	-16.84	N/A	1.31
5 MHz	-19.60	N/A	0
7 MHz	-18.35	116	4.75
9 MHz	-17.86	124	4.02
11 MHz	-18.80	N/A	2.48
15 MHz	-16.68	106	2.4
20 MHz	-14.70	92	1.76
25 MHz	-13.40	82	1
160 MHz	6.55	26	3.97

TABLE 1 - Results of the Nec-WIN frequency runs

how sensitive the antenna is to incoming signals. If the gain is negative, then the antenna has a loss compared with isotropic. For example, if the gain is calculated at -16 dBi, then it is -16 dB below isotropic, and -18.1 dB below a half wavelength dipole (-18.1 dBd).

The beamwidth is the angle, in degrees, between the -3 dB points on the antenna's horizontal or "azimuthal" pattern. The -3 dB points are called the "half-power points" and are the standard points at which antenna beamwidth is measured. This parameter is a measure of its directivity, and tells you something about the directions from which signals are accepted and rejected.

# It's Storm Season ... Be Prepared!

## New Generation Weather Alert Radio



ORDER RCV 26 **Only \$79<sup>95</sup>\***

**GROVE**

Grove Enterprises, Inc.

7540 Highway 64 West, Brasstown, N.C. 28902

(800) 438-8155 US & Can.; (828) 837-9200;

Fax (828) 837-2216;

e-mail: [order@grove-ent.com](mailto:order@grove-ent.com)

World Wide Web: [www.grove-ent.com](http://www.grove-ent.com)

\* Please add \$5.95 US Priority Mail or UPS shipping.

This top-selling, desktop weather radio not only receives all seven NOAA National Weather Service frequencies, but allows you to key in your location for Specific Area Message Encoding (SAME) weather alerts for your specific location! The digital display notifies you immediately of the type of alert, and a pair of contacts allows you to attach an external alarm such as a siren.

Powered by AC or internal battery (not included). Whip antenna for local reception, antenna jack for distant signals.

## Weather Alert Monitor

Crystal controlled for superb stability, this tiny receiver allows you to select any of the seven nationwide NOAA National Weather Service channels for immediate weather information. Listen to 24 hour voice weather broadcasts, or select automatic flashing light or siren for severe weather alerts. Sits on your desk or nightstand, or mounts on a wall. For strong signal areas, use the adjustable antenna, and in fringe areas, plug in your outdoor antenna for reliable reception. Comes with AC adaptor, or may be operated from internal 9-volt battery (optional) during power outages.



ORDER RCV 25 **Only \$39<sup>95</sup>\***

## Results

Table 1 shows the tabulated results for the random length Marconi modeling project. Notice that all of the HF band gains are less than isotropic, so the antenna will not work as well as a dipole. But then again, we know that to be true from experience. The resonant half wavelength dipole will work better on its own frequency, although performance deteriorates rapidly off resonance.

At the frequencies at which the -3 dB beamwidth could be calculated, the values vary from 82 to 124 degrees on HF. Notice, however, that the beamwidth is a lot narrower (26 degrees) on 160 MHz. This value is consistent with the higher gain on that frequency (6.55 dB).

The front-to-back ratio tells you something about the relative gain between the maximum lobe and some other point on the antenna. On a Yagi, for example, the pattern is essentially unidirectional, so the F/B ratio is the ratio of the gain between the front and the back of the antenna (and the value is usually quite high).

On a dipole, the F/B ratio is 0 dB because it receives equally well in both directions (Fig. 2). In this case, the notions of "front" and "back" are a bit nonsensical because the antenna is bidirectional. Perhaps a more meaningful measure in that particular case is the front-to-side ratio. The gain in the two directions perpendicular to the wire (90 and 270 degrees in Fig. 2) is about 2 dB. But the notches off the ends of the dipole are -34 dB.

Now let's take a look at the random length Marconi at various frequencies other than

**FIG. 2**

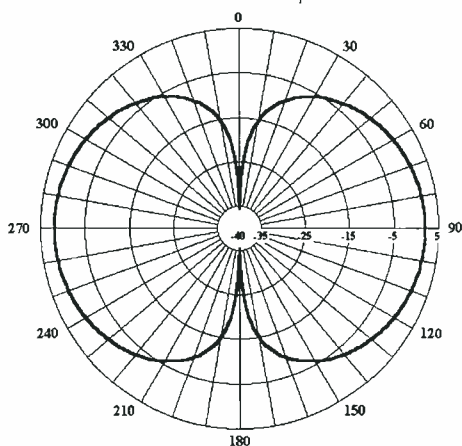

*Azimuthal pattern of a half wavelength 7.15 MHz dipole, spaced quarter wavelength above ground (shown for comparison). Antenna axis is 0-180 degrees.*

**FIG. 3**

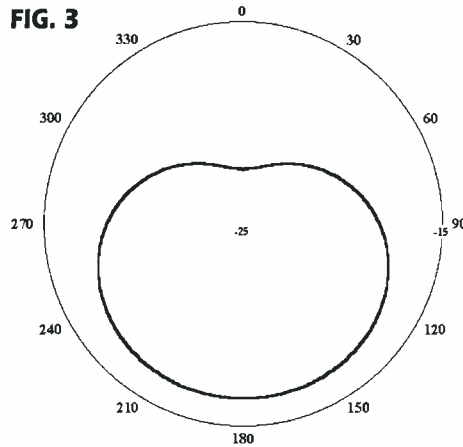

*Marconi pattern at 3 MHz. This antenna will have maximum pick-up at 180 degrees (the 30-foot high end), and minimum pick-up at the receiver end of the antenna (0 degrees).*

resonance. Figure 3 shows the gain at 3 MHz. Notice that it is basically a shallow cardioid something like certain radio direction finding antennas. The antenna axis is 0-180 degrees, so this antenna will have maximum pick-up at 180 degrees (the 30-foot high end), and minimum pick-up at the receiver end of the antenna. The gains at 120 and 240 degrees are approximately the same as the forward gain. The modeling software declared the beamwidth as "not applicable" (N/A), the gain as -16.4 dBi and the F/B ratio as 1.31 dB. At this frequency the Marconi will attenuate signals arriving from 0 degree direction.

At 7 MHz the pattern develops a couple backlobes (Fig. 4). I call this pattern the "teddy bear" for want of a better name. The gain was -18.35 dBi, the beamwidth 116 degrees and the F/B ratio was 4.75 dB.

**FIG. 4**

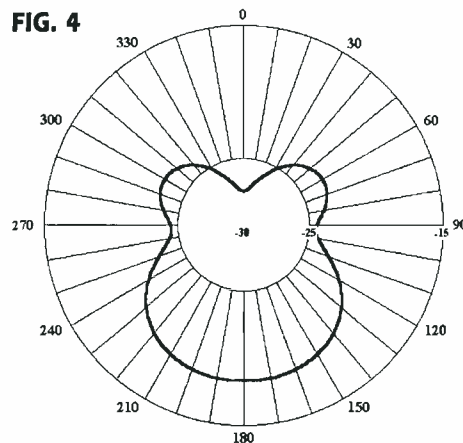

*Marconi pattern at 7 MHz*

**FIG. 5**

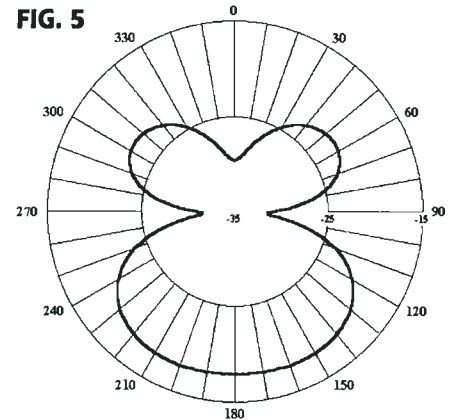

*Marconi pattern at 9 MHz*

When the frequency is increased to 9 MHz (Fig. 5) the "teddy bear" develops pinched ears. The gain is -17.86 dBi, and the beamwidth increases to 124 degrees. The F/B ratio is 4.02 dB, so is only marginally worse than the F/B ratio at 7 MHz.

At 11 MHz the teddy bear ears become less pinched (Fig. 6). The gain is -18.8 dBi, and the F/B ratio is 2.48 dB. For some reason I don't understand the software declined to declare a beamwidth.

When we get to 15 MHz (Fig. 7) the teddy bear dissolves into a multi-lobed pattern. In addition to the two backlobes, a pair of sidelobes has appeared. The gain is -16.68 dBi, and the beamwidth of the maximum lobe (at 180 degrees) is 106 degrees. The F/B ratio is 2.4 dB. This type of antenna is beginning to pick up signals from nearly all directions except 0 degrees. At the 0 degree point, however, there is a deep (40 dB) null, so signals from that direction are all but suppressed.

The pattern at 20 MHz is similar to that at 15 MHz, except that we now have two pairs of sidelobes. The gain is -14.7 dBi, and the beamwidth is 92 degrees. The F/B ratio is

**FIG. 6**

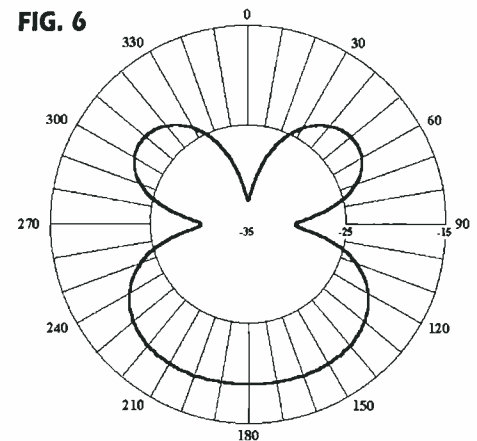

*Marconi pattern at 11 MHz*



# Quantities Limited! Call NOW!

**Lowest Prices EVER on these Bearcat scanners!**

Bob's Bargain Bin overstocks, factory tested, as-new condition.  
90 Day Warranty



Uniden BC 100 XLT handheld scanner: 100 memory channels, 29-54, 118-174, 406-512 MHz, 10 priority channels, automatic search, LCD display, snap-on battery pack, weather search, 15 channels per second scan/search, two second scan delay. Includes AC adaptor, antenna, earphone, carrying case, and manual.

ORDER SCN33RF **Only \$69<sup>95</sup>** plus \$5.95 US Priority Mail or UPS shipping.

Bearcat 60-XLT programmable handheld scanner: 30 memory channels, 29-54, 137-174, 406-512 MHz, 10 channel per second scan/search speed, one touch weather, built-in delay, memory back-up retains frequency programming for 3 days without AC power, low battery indicator, track tuning for crystal clear reception. Includes AC adaptor, antenna, and manual.

ORDER SCN32RF **Only \$49<sup>95</sup>** plus \$5.95 US Priority Mail or UPS shipping.



Uniden SC150 Sportcat handheld scanner: 29-54, 108-174, 406-512, 806-956 MHz (less cellular), 100 memory channels, 100 channels per second scan, 100/300 channels per second search, Data Skip, 10 priority channels, preprogrammed band search, one touch weather and much more! Available in Black or Yellow (specify color choice when placing your order). Includes AC adaptor, antenna, earphone, and manual.

ORDER SCN23RF **Only \$99<sup>95</sup>** plus \$5.95 US Priority Mail or UPS shipping.



Uniden BC220 XLT handheld scanner: 29-54, 108-174, 406-512, 806-956 MHz (less cellular), 200 memory channels, 100 channels per second scan, 100/300 channels per second search, 10 priority channels, Data Skip, preprogrammed service search for police, fire, emergency, aircraft and marine frequencies, one touch weather scans all national weather channels. Includes AC adaptor, antenna, earphone, and manual.

ORDER SCN34RF **Only \$149<sup>95</sup>** plus \$12 US Priority Mail or UPS shipping.



**ORDER NOW!**

# GROVE

Grove Enterprises, Inc.; 7540 Highway 64 West; Brasstown, N.C. 28902  
(800) 438-8155 US & Can.; (828) 837-9200; Fax (828) 837-2216;  
e-mail: [order@grove-ent.com](mailto:order@grove-ent.com); World Wide Web: [www.grove-ent.com](http://www.grove-ent.com)

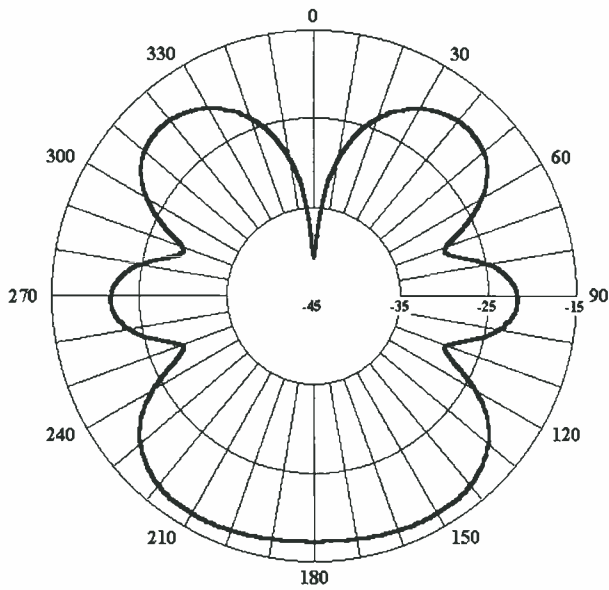

**FIG. 7 - Marconi pattern at 15 MHz**

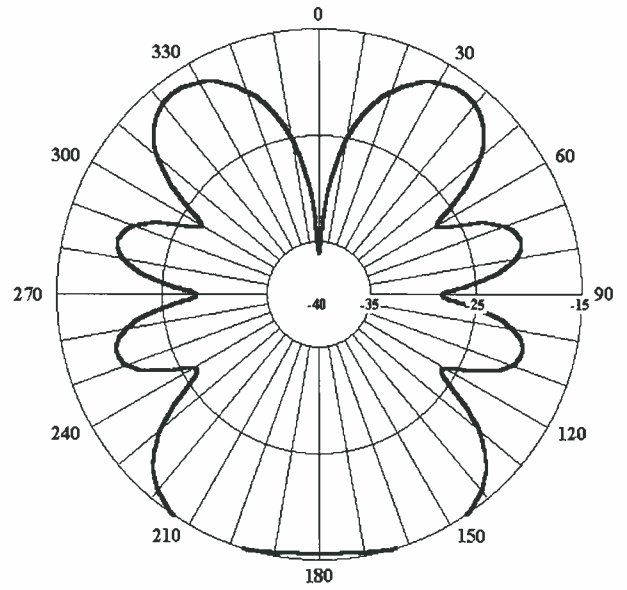

**FIG. 8 - Marconi pattern at 20 MHz**

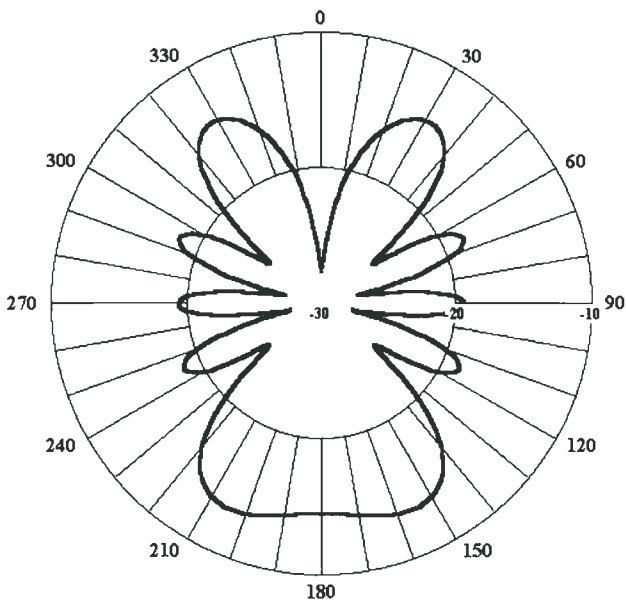

**FIG. 9 - Marconi pattern at 25 MHz**

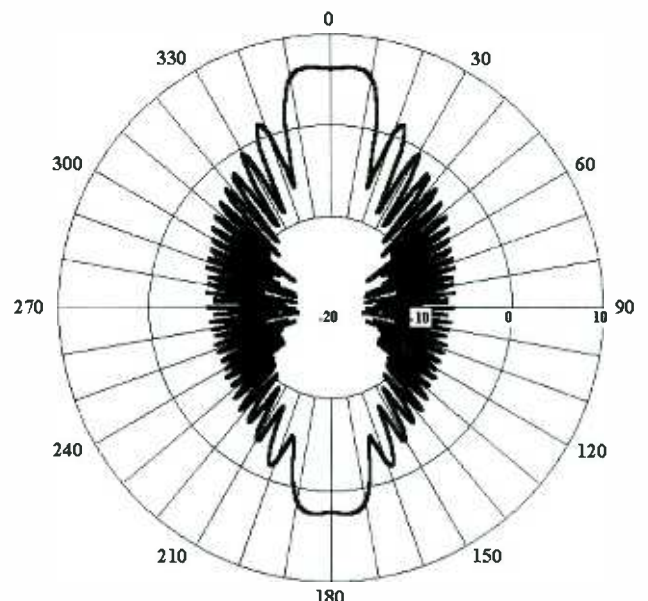

**FIG. 10 - Marconi pattern at 160 MHz**

1.76 dB. The notch at 0 degrees is -36 dB. At 25 MHz, a third set of sidelobes appears and the main lobe gets pinched in. That is, by the way, quite common with antenna patterns. It is like a balloon. That is, if you push in at one point some other points will expand outwards. The gain at 25 MHz is -13.4 dBi, the beamwidth is 82 degrees and the F/B ratio is 1 dB.

Now, let's look at the real surprise. At 160 MHz, in the VHF band, the Marconi antenna develops a large number of sidelobes. There is a main lobe at 0 degrees, and a minor lobe (almost as high as the main lobe) at 180

degrees. The two larger lobes are along the antenna wire, which is what is expected of a very long long-wire antenna. The gain is +6.55 dBi, and the beamwidth drops to a narrow 26 degrees. The F/B ratio is 3.97 dB. These numbers are not as good as a respectable 160 MHz Yagi or multi-element cubical quad, but they do indicate substantial performance at that frequency.

### Conclusion

The random length Marconi antenna is an easy to construct and convenient antenna.

But its performance varies considerably with frequency. As a result, you will see different results from different directions on different frequencies. The patterns in this article explain why you will see such differences in your listening.

<sup>1</sup> You can also get mini-NEC 3, plus other software, on the CD-ROM that comes with my book *Antenna Toolkit*, published by Newnes. It is available from Amazon Books (<http://www.amazon.com>).



# The Back Yard Beverage

By Douglas A. Blakeslee, N1RM

Listening for high frequency (HF) signals on the lower shortwave bands, 2.3 and 5 MHz, is not for the faint of heart. Weak signals, lightning crashes, and — on nights with good reception — a panoply of interfering signals are the lot of all listeners. At these low frequencies, the only simple way to make a major improvement in reception is with an appropriate antenna. For most of this century the simple antenna of choice has been the Beverage.

## H. H. BEVERAGE

Some famous pioneers of radio techniques are remembered because their inventions still carry their names. For example, oscillator configurations are named for Colpits, Hartley and Clapp. Howard H. Beverage, W2ML, tried a number of antennas for reception of transatlantic telephone circuits. While working for RCA, he experimented at 1.2 MHz — what is now the center of the AM broadcast band. He found that very long wires close to the ground produced excellent results, including low noise reception and good directivity.

Because of the proximity to the ground, the antenna is not efficient and thus not suitable for transmitting. Efficiency in reception is not a requirement at the frequencies of interest, as most signals are too strong, not too weak. The problem is sorting the ones of interest from the rest.

## BEVERAGES FOR AMATEURS

An important challenge for amateurs, after the shutdown of operation during World War I, was to get signals across the Atlantic. In 1921 the fledgling American Radio Relay League (ARRL) in 1921 sent Paul Godley, 2ZE, to a beach in Scotland with modern (for then) receivers to listen for amateur signals

from North America. His antenna of choice was the Beverage. Godley filled half a log-book page with reception reports. When the accomplishment was reported in ARRL's monthly magazine, *QST*, it said, "Get out those exclamation points Mr. Printer, *because we got across!*" This story was recently retold in *QST*.<sup>1</sup>

Radio amateurs moved to higher frequencies, driven away by commercial interests who wanted uncontested access to the lower frequencies. So, amateurs went up the radio spectrum, only to find that long distance (DX) communication was easier the higher the frequency, especially with smaller antennas and low power. The shortwave revolution was under way.

At the higher frequencies the Beverage antenna had no advantage, so the design was largely forgotten. For years after World War II, amateur operation of the 160-meter (1.8-MHz) band was restricted because of the Loran (long range navigation) system that operated within these channels. Once the Loran restrictions were removed, operation again became popular on 160, which also resulted in a new search for DX contacts.

Then, ARRL announced a new operating award, Five Band DXCC, for communicating with 100 different countries on five bands. Probably the most difficult aspect of the new award was the requirement for communication on 3.5 MHz, the 80-meter ham band. For both applications, reception from long distances brought the Beverage back to preeminence for reception.

## SIMPLE OR COMPLEX?

John Devoldere, ON4UN, in his excellent book *Low Band DXing*,<sup>2</sup> describes a number of Beverage designs, from simple to reversible to balanced wires thousands of feet long.

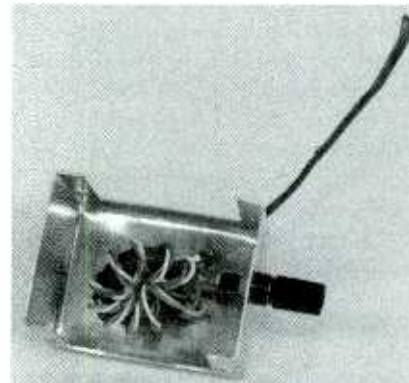

The broadband transformer is three wires twisted together and then wrapped around a toroid core. Connection to the receiver lead in is via the coaxial connector. The end of the Beverage antenna connects to the binding post, while the ground lead from the housing connects to the ground stake.

For those who don't have a farm or a backyard the size of multiple football fields, most of these antennas are impractical. However, John also mentions a simple Beverage that resembles an inverted V of wire, low to the ground at the high point and descending to ground level at either end. The V provides a configuration that does not allow much stray pickup on the downlegs of the antenna, enhancing directivity. Does it work? You bet!

This writer built a field of Beverage antennas atop one high point in the seven-mountain range in central Pennsylvania. The results of these long, single-wire antennas were outstanding. The easy test was to monitor the broadcast band. At the flick of a switch, different stations from different directions could be heard on the same frequency, with little or no interference to each other.

A change in employment led to a move first to Minnesota and then to Wisconsin. Reception was bad to impossible on the lower HF bands with regular wire antennas. The land available was way too short to accommodate even ON4UN's shortest design. The question became, could a very short Beverage be useful and effective? A search of literature came back with a resounding "no." But then, there was also no indication that anyone had ever tried.

With a number of trips to South America scheduled for business purposes, this writer thought it would be useful to listen to broadcasts from various countries in the region to listen to local language usage. The Latin band of 4.8 to 5.1 MHz was the place to listen (from Wisconsin). But, something better than a long wire antenna would be needed.

FIG. 1

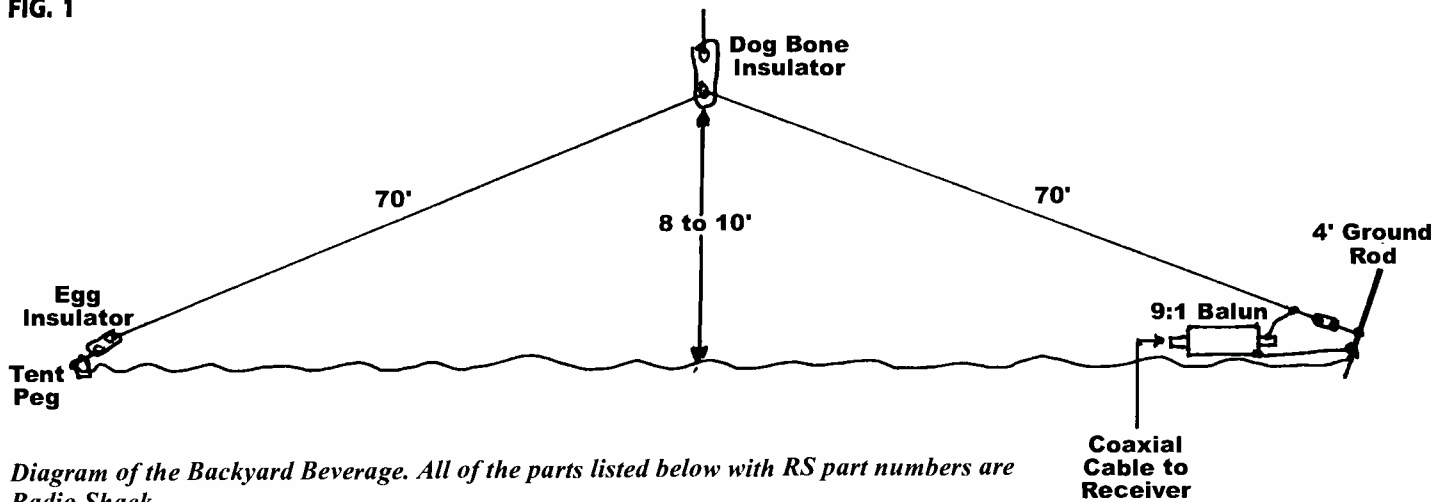

Diagram of the Backyard Beverage. All of the parts listed below with RS part numbers are Radio Shack.

- 1 — Stranded antenna wire, 70 ft, two needed (RS 278-1329)
- 2 — Egg antenna insulators, kit of two, (RS 278-1335), used at the ends of the antenna.
- 3 — Dog bone insulator (RS 278-1136) used to insulate the high point of the antenna.
- 4 — 4 foot ground stake (RS 15-530).

### A BEVERAGE FOR THE BACK YARD

The antenna that evolved in shown in Fig. 1. The size was determined by the space surrounding the house and the components available from Radio Shack. The center point is suspended from a corner of the house, some 8 to 10 feet above ground. The two ends droop to ground level. One end is held in place by a tent peg. The other requires a ground connection, which is provided by a short ground stake.

The feed end of the Beverage has a broadband transformer to match the impedance of the antenna (typically 400 to 500 ohms) to 50- or 72-ohm coaxial cable that provides connection to the receiver. The construction of this transformer is given in Fig. 2. Three wires are twisted together with five turns per inch. The wires must be color coded in some way so that the individual conductors can be identified for connection once the transformer is fabricated. Your author used hookup wire with different colors. An alternative is to employ enamel-coated wire color coded with fingernail polish or any other color source.

Once the wire bundle is wound around the toroid core, the end connections should be soldered together in the pattern shown in Fig. 2. In this implementation, the transformer is built into a small aluminum box. Another version was just soldered together including the feed cable and the ground connection, which was then covered with RTV silicone sealer. Either method works, although the latter is less expensive and avoids the problem of weatherproofing the box. For the box,

a plastic freezer bag sealed with freezer tape will last one winter season. The coaxial connector should still be coated with silicone sealer to prevent moisture damage.

In this design, the far end of the Beverage is unterminated, which means that the antenna will exhibit a bidirectional characteristic. For most monitoring purposes, this is not a problem, especially if there won't be a lot of strong signals from the back side. In this case, the rear of the antenna was going to be aimed at Siberia, not a hotbed of activity on the Latin band.

Terminating the Beverage at the far end with a 420-ohm carbon resistor will provide more unidirectional reception — with emphasis toward the terminated end. However, the grounding required at both ends of the antenna becomes more extensive — almost impossible over relatively nonconductive soil. Try the terminated version if you wish, but don't expect too much.

### AIMING

A very short Beverage has a wide coverage pattern off both ends (if unterminated). However, it is directional with good nulls (i.e. no reception) off the sides. Thus, it is vital to get the wire oriented in the correct direction. Your writer has found that local maps can be unreliable to determine north; a compass is usable if you have an accurate instrument, and if it is not surrounded by a lot metallic objects such as house wiring, power and telephone lines.

You also need to determine the difference between magnetic north and true north for

your location. These data are available, but there is a simpler method. Watch your local TV or the weather TV channel and determine sunrise and sunset for your area. Divide the times by two to find local "high noon." At that time, on a sunny day, drive a stake into the ground and note the shadow that results. It points very close to true north.

Once you have north determined, a protractor on the ground can show the offset needed for your wire antenna. In my case I wanted 25 degrees offset from the north/south line.

### RESULTS

For those who have never tried a Beverage, the first evening of monitoring will be nothing like what you have heard before. If you have another antenna, make sure to use an antenna switch so that you can do a quick comparison. Both the comparison between antennas and what you will hear on the Beverage will convince you that the small investment in the simple wire antenna was well worth the expense.

A good first check of the antenna is always on the AM broadcast band. With a copy of the *World Radio-TV Handbook*<sup>3</sup> in hand, check the stations that have near clear channels around the U.S. (Sad to say, there are not any "true" clear channels any more.) A first check from Wisconsin showed excellent reception from broadcasters in Lexington, Memphis, and Atlanta — just the correct direction for a path across to South America. Then, on to monitoring the Latin band.

If you listen every night for several hours,



## 9:1 Balun Transformer

To Antenna

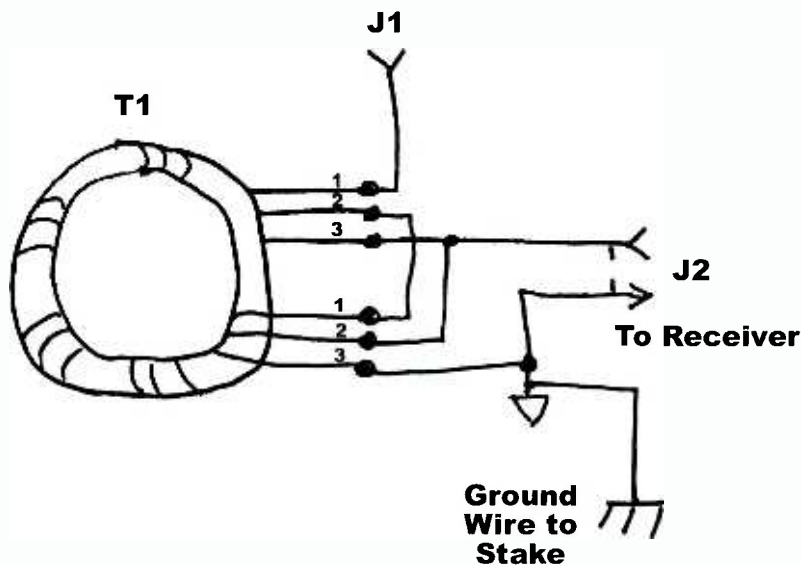

**FIG. 2** — Diagram of the matching transformer. The assembly is housed in a 2-3/4 x 2-1/8 x 1-5/8 aluminum box (RS 270-235). See the text for an alternative assembly method.

J1 — Binding post (RS 274-662).

J2 — Coaxial connector, female (RS 278-201).

T1 — 7 trifilar turns of wires, prewound together at 5 turns per inch, on Amidon FT-114-75 toroidal core. Any wire size from #20 to #30 will work, insulated or enamel-coated will work. The Radio Shack kit (RS278-1345) contains suitable wire. The wires should be color coded in some manner to allow appropriate connections. (Toroid cores are available from Amidon Associates, 250 Briggs Ave., Costa Mesa, CA 92626.)

sooner or later you are sure to hear almost everything. To evaluate the Backyard Beverage your author decided to limit the monitoring to two hours per night over four nights in late November and early December.

To determine if the receiver employed made a difference, the output of the Beverage was fed to an Icom 751 and to a Grundig 400 Yacht Boy. In general, the results between the popularly priced Grundig portable and the sophisticated ham radio transceiver were not much different — in situations with heavy interference, the selectivity and the bandpass tuning of the Icom were helpful, but only marginally. It would seem that the antenna is much more important than the receiver for this frequency band.

The results of the listening tests are shown in Chart 1. Clearly the little Beverage provided excellent results. The chart tells us that one may want to study Portuguese rather than Spanish, as stations in Brazil dominate the log. Of course, Brazil also covers a good deal of the land mass of South America. With such long distances to cover, shortwave broad-

casting is extensively utilized in Brazil by domestic stations.

Because the antenna is bidirectional, two unexpected stations were heard. One was the time station in Irkutsk, Russia, on 5004 MHz. The other was China CNR2 broadcasting from near Beijing.

Requiring only a hank of wire and a transformer that is easy to fabricate, you might want to try a Backyard Beverage. It works well from the broadcast band to over 7 MHz. The antenna is clearly for the winter season. Once the grass starts to grow, and the lawn needs mowing, the Beverage can be put away to await the next low frequency DX season.

### BLAKESLEE FOOTNOTES

- 1 "Hams Span the Atlantic on Shortwave," QST, December 1996.
- 2 Devoldere, *Low Band DXing*, ARRL, Inc., 1987. Available from ARRL, 225 Main Street, Newington, CT 06111.
- 3 Bobbett, *World Radio-TV Handbook - 1999 Edition*, 1999. Available from Grove Enterprises, 7540 Hwy. 64 W, Brasstown, NC 28902.

## Latin Band Log (Chart 1)

This chart shows stations monitored over a total of 8 hours on four days.

Freq	Country	Station
4755	Brazil	R. Educacao
4765	Brazil	R. Rural
4780	Ecuador	R. Oriental
4790	Peru	R. Atlantida
4799.8	Ecuador	R. Popular
4805	Brazil	R. Atahuapha do Amazonas
4820	Honduras	R. Voz Evangelica
4825	Brazil	R. Cancao
4830	Venezuela	R. Tachira
4835	Brazil	R. Atalaia
4845	Brazil	R. Cabocia
4875	Brazil	R. Roraima
4885	Brazil	R. Clube do Para
4905	China	CNR2
4915	Brazil	R. Difusora
4919	Ecuador	R. Quito
4930	Honduras	R. Internacional
4939	Venezuela	R. Continental
4945	Brazil	R. Nacional, Porto Velho
4955	Colombia	R. Dif. International
4960	Ecuador	R. Federacion Shuar
4974.6	Peru	R. del Pacifica
4980	Venezuela	Ecoss del Torbes
4985	Brazil	R. Brazil Central
4991	Peru	R. Ancash
4995	Peru	R. Andina
5000	Venezuela	Naval du Capital (under WWV)
5004	Russia	Time station, Irkutsk
5020	Ecuador	La Voz del Upano
5025	Peru	R. Quilabambia
5030	Ecuador	R. Catolica National
5035	Brazil	R. Aparecida
5045	Brazil	R. Cultura do Para
5075	Colombia	Caracol Colombia

## FREE CATALOG

**Packed with great books for radio communications & electronics hobbyists.**

- ★ FREQUENCIES
- ★ MODIFICATIONS
- ★ REPAIRS
- ★ TROUBLESHOOTING

*Everything you're looking for!*

Largest selection of how-to & info books for scanner, CB & ham radio fans, beginners to experienced monitors.

### CRB RESEARCH BOOKS

PO Box 56-M, Commack NY US 11725  
PHONE: 516-543-9169  
FAX: 516-543-7486  
ONLINE: <http://www.crbbooks.com>

# Constructing an L-Band Feed Horn

By J.S. "Stu" Gurske, K9EYY

**R**eaders of *Monitoring Times* have observed the gradual transition of international broadcasts, weather facsimile images, and communications from HF (high frequency) to satellites. The serious monitor has therefore had to change from a simple antenna and HF receiver to dishes, feed horns, LNAs (low noise amplifiers), Bias-Ts, and receivers capable of hearing these signals, which are often located in the L-band (1 to 2 gigahertz) portion of the radio spectrum.

One of the items needed for this transition to satellites is a feed horn. There are few sources of feed horns which will operate in the L-band where Inmarsat and several other popular communications satellites are located. This project will show you how to construct a circularly polarized feed horn; finally, you can switch from GOES 8 to GOES 9 without having to go outside and rotate your standard feed horn!

For years, experimenters have used a coffee can as the cavity with a single probe inserted in the can, but notwithstanding the problem of a rusting coffee can after a few months, that approach creates problems relating to the polarity of the signals. In order to achieve the proper polarity, it is often necessary to purchase an expensive combiner and a phasing harness, further increasing the signal loss.

The feed horn featured here is circularly

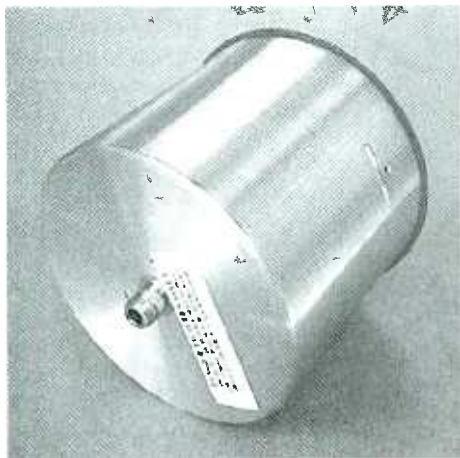

*Photo 1 shows what the completed feed horn looks like. Notice the single N connector protruding from the rear of the can.*

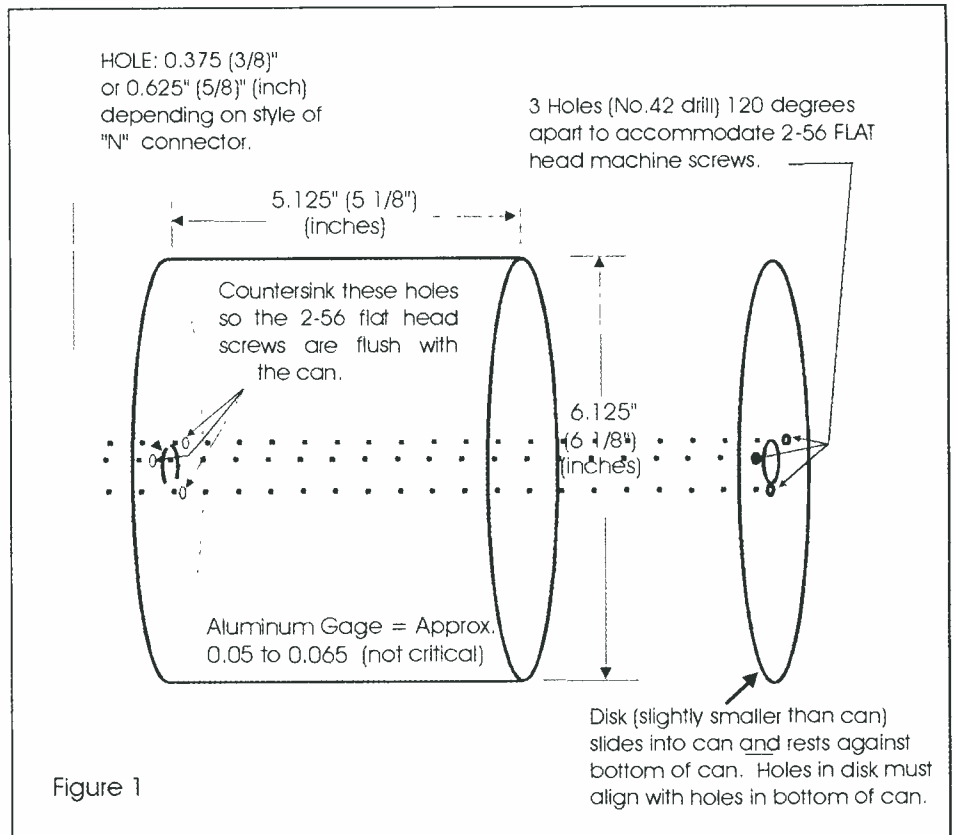

polarized and needs no further attachments or harnesses. Your low noise amplifier is attached to the feed horn N connector, and the coaxial cable is attached to the connector on the output of the LNA — and you are ready to listen to the satellites.

This feed horn will receive signals from about 1500 to about 1700 MHz. While it will not provide optimum performance without tuning with a sweep generator or some other method, it will work "as is" and give you many hours of listening pleasure. If you do get access to a sweep generator to tune the feed horn, you can easily obtain a return loss of at least 25 dB at 1691 MHz.

While the same feed horn is available from Swagur Enterprises ready-made or in kit form<sup>1</sup>, here's how to build it yourself:

## Construction

Begin by collecting the materials listed in the materials list at the end of the article (or purchase the kit).

To prepare the can or enclosure, refer to **Figure 1**. Measure the flange (outer ring) of the N connector you have selected. Its size will determine the size of the hole you must make in the back plane of the enclosure (can). The size will usually be either 3/8-inch (0.375") or 5/8-inch (0.625"). Next, make a mark in the exact center of the backplane of the can.

From this center point, measure outward 0.850-inch and draw a circle. Then mark three equally spaced locations (i.e. 120 degrees apart) on this circle. **Note:** this dimension is very important! You will be aligning these three holes with the three holes you will be drilling in the disk, as well as with the three holes you will be making in the PVC pipe later. Be very careful to get these holes spaced properly.

Now drill clearance-size holes (No. 42 drill) to accommodate three 2-56 size screws. Countersink the holes so the three flat headed 2-56 screws will lie flat and flush with no protrusion above the back plane of the can.



**Note to U.S. consumers only:** It is unlawful to import, manufacture, or market cellular-capable or cellular-restorable scanners into the U.S.

## We have Scanners with 800MHz coverage!

AOR AR-5000, 5000/3+, 3000, 8000  
 Yupiteru MVT-9000, 7100, 8000  
**OPTOELECTRONICS** Xplorer, R11  
 nearfield receivers

**New Welz/Standard WS-2000** (very tiny)

WinRadio WR-1000i, WR3000i

ICOM R9000, R8500, R100, R10, PCR1000

### Icom R-10

500KHz ~ 1300Mhz coverage  
 AM/NFM/WFM/USB/LSB/CW Modes  
 100 x 10 banks = 1000 memories  
 Computer Control interface  
 Selectable Step Size  
 True SSB (Lower and Upper)



*We do Modifications for your Scout!*  
 All Orders Shipped Expedited

### **ATLANTIC HAM RADIO LTD.**

(416) 636-3636 ahr@interlog.com 368 Wilson Ave  
 (416) 631-0747 (fax) Downsview, ONT  
 www.interlog.com/~ahr/scan.htm Canada M3H 1S9

# NOT JUST FOR RACING!



**RE2000<sup>Alpha</sup>**  
Racing Scanner

Program this revolutionary scanner on your computer... by the scanner keypad... or let us do it for you!

The RE2000Alpha Racing Scanner comes pre-programmed, has Alpha-Numeric Display and is PL/DPL Private Line Compatible!

**CALL FOR CURRENT PRICE!**

PC Programming Kit **\$29<sup>95</sup>**

**FOR INFORMATION OR TO PLACE YOUR ORDER, CALL**  
**1.800.272.7111**  
 Visit us on the web at [www.racingelectronics.com](http://www.racingelectronics.com)





Listening is only half the fun...

# POPULAR COMMUNICATIONS

is the other half.

*If you enjoy radio communications in all its variety, you'll love Popular Communications*

Since 1982 Pop'Comm has delivered thousands of pages of great reading for both the radio enthusiast and the professional communicator.

Name your favorite interest... Popular Communications is there for you. Whether you're into Short-wave Listening, Scanner Monitoring, searching out Pirate Radio broadcasters, CB Radio, Satellite Broadcasting, ACARS, or Ham Radio; you name it, we cover it, every month.

**Popular Communications**

Subscribe today and save over 54% off the newsstand price. Save even more with two or three year subs!

YES! Enter my Subscription to Popular Communications today!

Name \_\_\_\_\_

Address \_\_\_\_\_

City \_\_\_\_\_ State \_\_\_\_\_ Zip \_\_\_\_\_

( ) Check ( ) MasterCard ( ) VISA ( ) AMEX ( ) Discover

Card No. \_\_\_\_\_ Expires \_\_\_\_\_

Signature \_\_\_\_\_

	USA	Canada/Mexico	Foreign Air Post
1 Year	<input type="checkbox"/> 25.95	<input type="checkbox"/> 35.95	<input type="checkbox"/> 45.95
2 Years	<input type="checkbox"/> 45.95	<input type="checkbox"/> 65.95	<input type="checkbox"/> 85.95
3 Years	<input type="checkbox"/> 65.95	<input type="checkbox"/> 95.95	<input type="checkbox"/> 125.95

Allow 6 to 8 weeks for delivery

**FOR FASTER SERVICE FAX 1-516-681-2926** MT 98

**Popular Communications** 25 Newbridge Road, Hicksville, NY 11801 Telephone (516) 681-2922

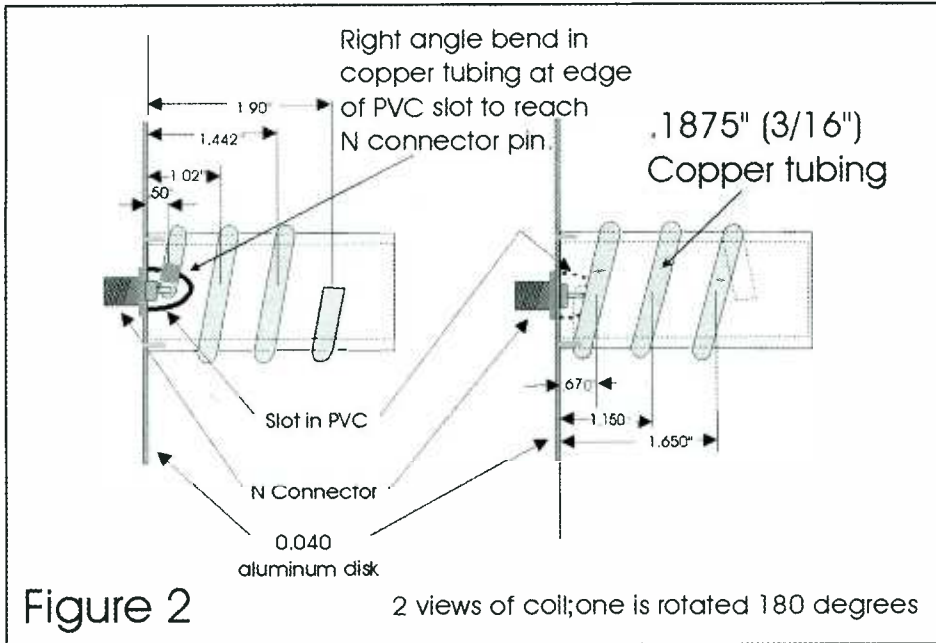

Using the diameter of the ring (flange) around the N connector as the size, make a hole in the center of the back plane of the can. This size hole will allow the N connector to remain flush with the surface of the back plane of the enclosure (can). It is recommended that if you have a punch, use it instead of drilling to make a cleaner hole.

Figure 2 shows two views of the disk (seen on edge), the PVC pipe, the coil and the way it is connected to the N connector. Look closely at it and how it all fits together. This assembly will slide into the can and be secured by the three 2-56 flat head machine screws. The three screws hold the entire assembly together.

Now construct the disk as shown in Figures 1 and 2.

Figure 3 shows the detail of construction for the PVC pipe. Be sure to "true up" the ends of the PVC so it will stand at 90 degrees to the disk when attached. Note there are three holes on each end of the pipe. The holes on the end opposite the slot will be used to hold the cover in place. Thread them also.

Be sure to locate the slot so it does not interfere with any of the three holes in the pipe. This kind of PVC can be found at most hardware stores. It is simply regular drain pipe used in plumbing projects. It measures approximately 1.5 to 1.6 inches inside diameter and about two inches outside diameter.

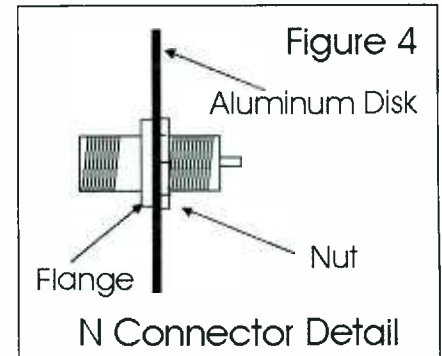
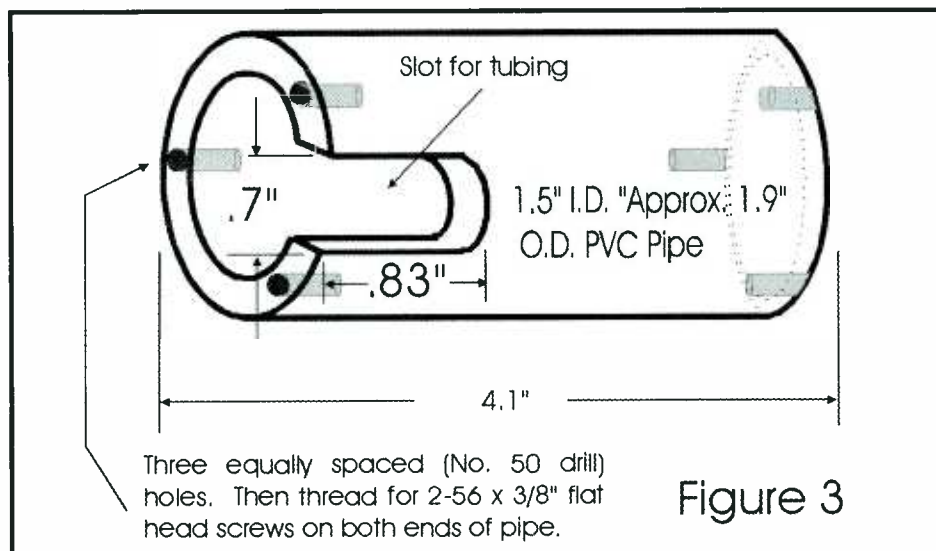

Figure 4 shows how the N connector is attached to the disk which fits inside of the can. Note how the flange is attached to the disk. When you make the hole in the can it should clear this flange. The entire assembly will be held in place with the three 2-56 screws which go through the can, then pass through the holes in the disk and finally are screwed into the PVC pipe which you will have threaded on both ends to receive the 2-56 screws.

Figure 5 shows how to prepare the copper tubing for making the coil. With a hammer or vise, flatten about 0.3-inch on one end of the tubing. Center punch the middle of the flat area and drill a hole just large enough to let the center conductor of the N connector fit snugly into the hole.

#### 0.1875" (3/16") x 22" Copper Tubing Detail



Flatten end of Copper Tubing. Then drill a hole just large enough to accommodate the center conductor of the "N" connector you are using.

Then wind the copper tubing around the PVC pipe in the direction shown in Figure 2.

Figure 5

Now refer to Figure 2 once again. Wind three turns of copper tubing around the PVC pipe in the direction shown. We recommend you temporarily attach the N connector to the disk and the disk to the PVC pipe as follows:

1. Attach the N connector to the disk
2. Solder the end of the copper tubing to the N connector.
3. Then, let the copper tubing stick out of the slot in the PVC pipe.
4. Temporarily attach the disk to the PVC pipe.
5. Wind the coil.



This anti-clockwise spiral assumes you will be pointing the feed horn at a dish. If you do not want to use the feed horn that way, you may want to wind the coil in the opposite direction. The dish reverses the circular polarity, so if you want right hand circularity and are using a dish, then wind the coil as shown (i.e. left hand).

Figure 6 and the photo give an overall view of how all of the parts fit together. The main points are that (1) the flange of the N connector is flush with the back of the can (i.e. flange slides into and does not rest on the back of the can), and (2) the three 2-56 screws hold it all together by resting in the counter-sunk holes in the can and through the disk and then are screwed into the PVC pipe. Now drill a 1/8-inch drain hole approximately 1.1-inch from the rim of the can.

Finally, attach a cover which is transparent to microwaves using the three threaded holes in the end of the PVC pipe. If you do not know if your cover will pass microwaves, put it in your wife's microwave oven for a few seconds. If it gets warm, it is absorbing microwaves. If it stays cool to the touch, you probably can use it. Most black covers have carbon imbedded in them and cannot

be used.

If you use 2-56 screws to fasten the cover in place, do not tighten the screws. Leave about 1/16-inch of the screw showing. Otherwise the cover may pop off in the hot weather.

### Construction Notes

The dimensions given for the placement of the turns of the coil in Figure 2 are approximate. If you want to tune the feed horn, you will find these dimensions will change. We provide them for those who do not have access to a sweep generator or similar device for tuning the device.

When trying to determine if a coil is clockwise or anticlockwise, look at the way you would turn it to get it to screw into the ground or some other object. If you had to turn it anticlockwise, it would be left hand circular. If on the other hand, you had to turn it clockwise to get it to screw into the ground, it would be right hand circular.

When attaching the copper tubing to the N connector center conductor, try to get the end of the tubing as close to the connector as you can without shorting it to ground. This will improve its impedance and make it work better. You might want to round off the end of the flattened tubing to reduce the chance of shorting the corners to ground.

If this article tantalizes you, but you need more convincing before you build, imagine receiving your own weather facsimile pictures on 1691 MHz off the GOES bird. Or order a reprint of "Microwave Monitoring: INMARSAT Loud And Clear" Part I, by John Wilson<sup>2</sup>. Part one is a comprehensive picture of who uses the satellite and what traffic you can expect to hear — including actual loggings by the author. Wilson used the traditional coffee can feedhorn (constructed in Part II), but now you can benefit from the development of the Swagur Horn and get better results from a simpler design. If you already have the receiver that covers the frequencies, why not give the satellites a try?

*Stu Gerske is President and CEO of Swagur Enterprises, Inc. He has developed a complete line of INMARSAT and weather satellite interception products.*

### Parts Listing

1. Can (enclosure) per figure 1.
2. Aluminum for disk per fig. 1.
3. PVC pipe per figure 3.
4. 3/16" x 19" copper tubing.

5. 1 each N connector.
6. Six each 2-56 flat head stainless steel machine screws.
7. Cover for end of can.
8. No. 42 and 50 drills.
9. One each 2-56 tap.

### Footnote:

- <sup>1</sup> Kit of materials: As a convenience for readers of *Monitoring Times* magazine, Swagur Enterprises will make available for a limited time, a kit of most of the materials needed for this project. It will consist of all of the items listed above except for the drills and tap. None of the items will be drilled or prepared except for the disk which will fit into our enclosure (can) and have a center hole and the three holes for the 2-56 screws. Price \$87.50 plus shipping (U.S.). The already-constructed feedhorn is \$120. Please contact us at 608-592-7409 or e-mail us at swagur@execpc.com. Our web site is located at [www.swagur.com](http://www.swagur.com).
- <sup>2</sup> *Monitoring Times*, February 1994. Reprints are \$3 plus SASE from Grove Enterprises.

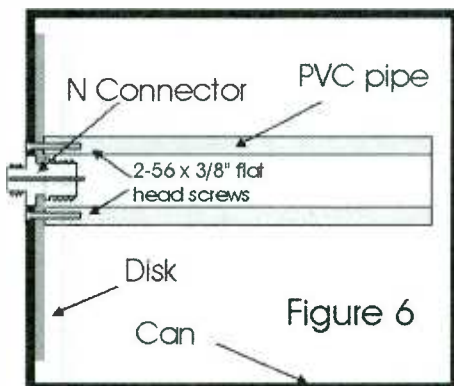

## GORDON WEST HAM TEST PREP TAPES BOOKS • SOFTWARE • VIDEOS

Prepare for your ham test with "Gordo" WB6NOA as your personal instructor.

- **THE THEORY** on audio cassettes
  - No-Code Technician (4 tapes)... \$19.95
  - General Class (2 tapes) ..... \$ 9.95
  - Advanced Class (4 tapes) ..... \$19.95
  - Amateur Extra Class (4 tapes) ..... \$19.95
- **THE CODE** on audio cassettes
  - Learning CW (6 tapes) ..... \$29.95
  - General Class CW (6 tapes) ..... \$29.95
  - Extra Class CW (6 tapes) ..... \$29.95
- **STUDY MANUALS** by "Gordo"
  - No-Code Technician (2&3A)..... \$12.95
  - General Class (3B) ..... \$ 9.95
  - Advanced Class (4A)..... \$11.95
  - Extra Class (4B)..... \$11.95
- **IBM SOFTWARE** with manual
  - No-Code Technician (2&3A) ..... \$29.95
  - General Class (3B) + Code ..... \$29.95
  - Advanced Class (4A) + Code ..... \$29.95
  - Extra Class (4B) + Code ..... \$29.95
  - Morse Software Only ..... \$ 9.95
- **VIDEO** with manual
  - No-Code Tech Video Course ..... \$29.95

Add \$3.00 shipping charge - 3 Day Service  
VISA, MasterCard, Discover & AMEX Accepted

**The W5YI Group, Inc.**  
P.O. Box 565101 • Dallas, TX 75356

Call Toll Free **1-800-669-9594**

# A Volunteer for the US Coast Guard Auxiliary

By Dan Renfro, WA4PXV

I've always known a little bit about the U.S. Coast Guard Auxiliary, mainly through their frequency assignments or occasional magazine articles. Such was the case a few years ago when *The Lake Norman Magazine* published a small story on the local auxiliary unit in North Carolina.

I wrote the author a note to pass along to someone in the auxiliary. A few months passed, but I received no reply. Then one day I heard a distress call on 156.800 MHz (marine channel 16). After the third call I went back to the vessel and got the necessary information, called my local sheriff's department to let them contact the appropriate agency, and maintained radio contact throughout the event.

About two hours later one of the Coast Guard Auxiliary units called me on the radio to thank me. When he found out where I was (about forty miles from Lake Norman) he could hardly believe I would be able to talk to him — much less talk to a boat on the water. He asked if I might know Dan Renfro who also lives in Hickory, North Carolina, and works on radio equipment. I assured him that I was he. He had my letter right there with him.

Basically I had said that I was a radio engineer and like to put together radio systems; and that if the Coast Guard Auxiliary wanted some help in that area, I would do what I could. I had plenty of equipment in the 136-150 MHz range, radios, filter cavities, antennas, etc. There was a mountain almost on top of the lake that would be very nice for them.

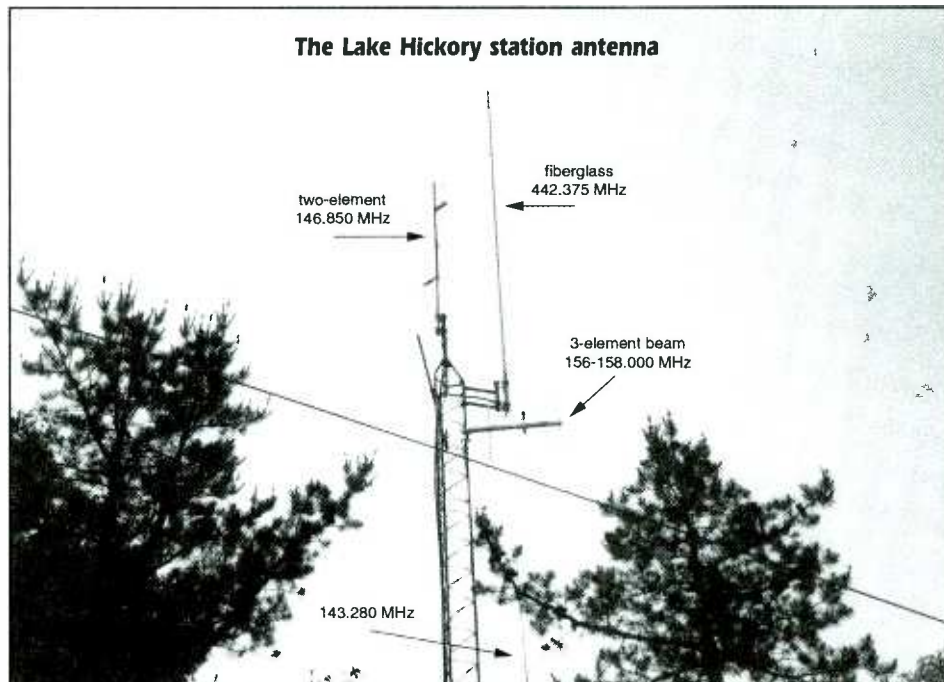

I had an ulterior motive: there were at least two VHF paging transmitters that were always causing problems by not having filters, having loose RF connectors, and bad installations. An emergency services group could put more pressure on the paging companies to clean up their systems — providing a fringe benefit to the ham radio community!

Unfortunately for my scheme, the fellow on the phone said there was not enough activity to support a radio repeater. I guess I would just have to continue playing Civil Air Patrol (CAP), ham radio and a few other special projects I was involved with.

A few years later my radio and CAP buddy, Reid McKay, WA4DSZ, mentioned he was going to a Coast Guard Auxiliary meeting down at Lake Norman. They might want to start a unit at Lake Hickory. He volunteered to drive, so we both went. Within a few months we were charter members of the US Coast Guard Auxiliary, Lake Hickory Flotilla 17-03. Right off we passed the communications test and got our stations checked out.

Lake Hickory is quite long, and boat-to-boat VHF is, at best, probably five to six miles. Reid, with a 3 dB gain vertical and 4-element beam, could just barely cover the entire lake, but a lot of areas were spotty. I have a 9 dB gain, 4-dipole array pointed toward the lake, and although my distance is 5 miles from the lake, I have greater altitude than Reid's lakeside location.

We tossed around the idea of a remote base somewhere and asked about radio link channels. Yes, they were available, but no

one knew exactly what to do to request them. The entire auxiliary is authorized 143.280 MHz for use within the US and its possessions. After several lunch discussions, we drew up some plans, using one Motorola Micor on 143.280 simplex and another one on 156.300, 156.800, 157.050 and 157.100 — all simplex with a control board being set up in cross band mode. We would also use a scan head for the marine channels with priority being set on the dialed-up channel — all controlled by DTMF (dual tone multi-frequency touch-tone system).

It worked pretty well, but the limitations of using a simplex channel would soon become apparent. Only someone who was highly skilled could operate changing channels in a dense radio traffic environment.

Reid has a mountain top amateur radio site just north of Lake Hickory and that is where we placed this system. We used a 3-element DB Products heavy duty beam pointed at Lake James (west about 40 miles) for the 156 MHz and a Hustler G-7 ground plane for the 143 MHz. Off the side of the beam was Lake Norman, and we achieved almost total coverage of that lake also.

## Fine Tuning the System

Every month or so a "bug" would show up, requiring a trip to the mountain. The system was completely battery-powered (I never rely on the power company during emergencies), and after some excessive-use days the charger would not always catch up. Then one day ... Boom! A direct lightning strike to the 440 MHz ham repeater melted that radio and



severely damaged all the other equipment.

The Coast Guard was top priority, so within a week it was back on with new power amps, squelch boards and scan board. A week or two later the VHF ham repeater got back on and a year later ... the UHF, which still has problems with the new radio.

We had proved how beneficial the system was, even with its limitations. We went up the chain of command for a set of repeater channels. After a month we were basically told to pick our own channels and when the new system is on the air to advise them what the frequencies were. Wow! If the Civil Air Patrol was like that, we could have some humdinger systems.

Anyway, I got out a lot of frequency manuals and my "outdated" government master file to find some suitable channels. On my initial start list, I had about 250 channels. As the list got smaller and smaller, I finally settled on 143.575 MHz for the input and 149.050 MHz for the output.

I got another 142-150 Micor for the repeater, and this time I got a DOE surplus Motorola Syntor X for the link radio. I programmed all the government marine channels in it with different scan lists per priority channel. We can now disable the scan if needed and change channels even while the link is receiving — the marvels of full duplex.

One problem with the link radio scan is if someone does not specify what channel is being used, it can be very difficult trying to figure it out. The repeater is standard carrier at all times and the link transmitter only activates when the proper subaudible tone is used.

The Hustler antenna was replaced by a heavy duty Celwave dual dipole and the three element beam got a new piece of 1/2-inch feedline thanks to the lightning strike. Lightning protection methods were stepped up quite a bit on all equipment.

With no filters at all (except the duplexer) the system worked fine except when using the link transmitter. When it was activated, the repeater receiver got severely overloaded. I put a 12-inch pass cavity on the receiver, then a 12-inch cavity on the transmitter (in case of mixing). Neither helped, so I left them on anyway. I would have to clean up the Syntor X transmitter.

The Syntor X, being a synthesized type radio, means the transmitter has much more sideband noise than an individual crystal-per-channel transmitter. This particular radio was designed for the 148-174 MHz range with no retuning. I already retuned the re-

**North Carolina Lake Coast Guard Auxiliary Channel Assignments**

**All are US channel plan**

Channel 21: Falls Lake, Roanoke Rapids Lake, Tar River, Moss Lake, Lake Hickory, Lake James, High Rock Lake, Hyc Lake, and Lake Reidsville

Channel 23: Harris Lake, Badin Lake, Lake Gaston, Lake Norman, and Lake Townsend

Channel 83: Lake Jordan, Lake Tillery, Lake Macintosh, Kerr Lake and Lake Wylie

ceiver preselectors for somewhat narrower bandwidth, which helped the sensitivity about 10 dB, and I'm sure helped the front end selectivity quite a bit. Still, the transmit problem ... With almost one MHz between the lowest and highest frequency, a typical band pass filter would be useless. There are no tuning adjustments on the transmitter to help clean it up. Now what?

I did have some military receiver dual cavity pass filters that would cover the 156 MHz range. They are built really tough and in the past I have used them on 100 watt systems in both pass and reject configurations, so I knew they should hold up. But what about the bandwidth? Too much ... too little? The "Q" factor is much lower than a normal pass cavity, and I knew the bandwidth would be somewhat wide.

With my half-watt portable I tuned one up — it looked almost perfect. I could get the same loss at both frequency extremes. At another there was a change in tuning — very slight. Now for the real test. I used my 100 watt Motorola Maratrac and checked both extremes — about 70 to 80 watts out it was still looking good. I balanced the high power signals, then gave the filter its endurance test: about 15 minutes of 100 watts continuous input. The filter got warm but not hot and it stayed tuned.

Now for the freezer test! I unhooked the cables and carefully put the filter unit in my freezer, taking care not to move the tuning knobs. After a few hours, I hooked it back into the test setup. At one frequency extreme, there was no effect, but at the other there was maybe 2 more dB or loss as the power there was 40-50 watts. Good enough for me. We had our one meg bandpass filter — the system worked perfectly by adding it to the link radio.

## Catawba Valley on the Air

The repeater identification is "U.S. Coast Guard Auxiliary Catawba Valley Radio" or many times just, "Catawba Valley Radio." The Morse code ID says "USCG AUX," but only on 149.050. Unless the system is in use, most of the time we leave it on the all-scan so any traffic on marine channels 6, 16, 21, 22,

23, 81, 82, and 83 will be rebroadcast on 149.050 — a scanner in the sky, so to speak.

On the average summer day at midafternoon, the receiver consistently picks up Louisville, Kentucky; Charleston, South Carolina; and Tybee, Georgia. During some mild band openings, New Orleans, Louisiana; Miami, and Clearwater, Florida; and Boston, Massachusetts, have been easily copied. I'm wondering what a major band enhancement will bring in! I've also been thinking about adding a remote-controlled antenna switch and putting up another link antenna to better cover the Lake Norman area.

Besides playing radio, the Coast Guard Auxiliary is lots of fun. Many training activities take place on the water. There's also lots of classroom training available for those who wish to stay on land. Also, my area is authorized one weekend per month to go to a Coast Guard base on the Atlantic for training or being crew members alongside them. Just think ... actual high seas rescue missions!

If you have some time available and want to meet some really great folks, then look toward the U.S. Coast Guard Auxiliary. If a unit is not very local, try checking out the Civil Air Patrol. Both of these emergency service organizations have much to offer anyone with some interest and expertise in radio communications.

**FREE  
SAMPLE  
COPY!**

**ANTIQUE RADIO CLASSIFIED**

*Antique Radio's Largest-Circulation  
Monthly Magazine*

Articles - Classifieds - Ads for Parts & Services  
Also: Early TV, Ham Equip., Books,  
Telegraph, 40's & 50's Radios & more...

*Free 20-word ad each month. Don't miss out!*

 1-Year: \$39.49 (\$57.95 by 1st Class)  
6-Month Trial - \$19.95. Foreign - Write.

A.R.C., P.O. Box 802-P14, Carlisle, MA 01741  
Phone: (978) 371-0512; Fax: (978) 371-7129  
Web: [www.antiquradio.com](http://www.antiquradio.com)

# AERIAL MAGIC

By Mike May

*Fractal antennas are better at picking up signals and can receive them over a wider range of frequencies ... but nobody is exactly sure why.*

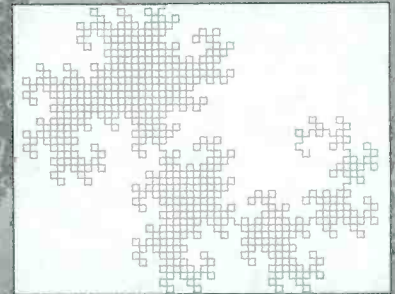

When Nathan “Chip” Cohen decided to set up a ham radio system at home, he hit a snag. The lease for his apartment in the center of Boston stipulated that he could not erect an antenna outside the building. Without an antenna he couldn’t send or receive radio signals. A small problem, but the answer he came up with has changed his life.

Instead of using a conventionally shaped antenna, Cohen made something entirely different. He cut a sheet of aluminum foil into the shape of a mathematical pattern known as an inverse Koch curve and stuck the pattern onto a sheet of paper. An inverse Koch curve is a fractal that looks like a series of triangles stacked on top of each other like a pagoda. Like all fractals it is “self similar” — it appears the same regardless of the scale at which it is viewed.

Cohen connected the foil to his radio receiver to see if it might serve as a covert antenna if he mounted it outdoors. To his surprise, the fractal foil pattern worked well and for a while Cohen was able to continue his hobby without arousing suspicion. “It didn’t seem very revolutionary at the time.”

That was in 1988. Today, Cohen’s experiment has made him a pioneer in the new field

of fractal antenna design. It turns out that fractal antennas have many advantages over their conventional counterparts. For a start, they are smaller — a fractal antenna for a mobile phone can be made the size and shape of a 35-millimeter photographic slide and

can be built into the casing. It could even be printed like an integrated circuit. Fractal antennas are also better at picking up signals and can receive them over a wider range of frequencies.

But there’s a challenge ahead. While the

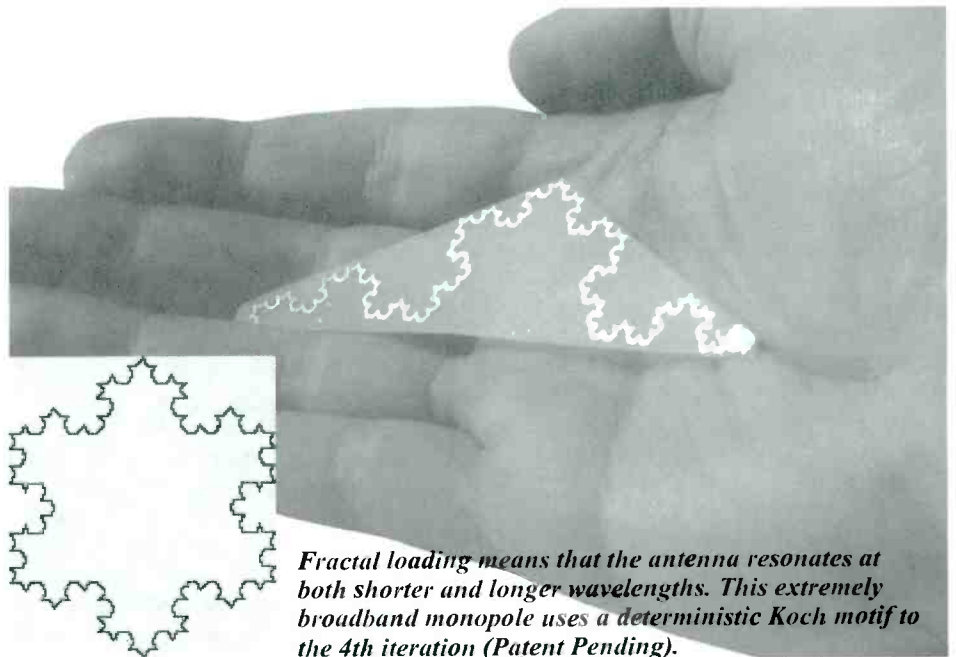

*Fractal loading means that the antenna resonates at both shorter and longer wavelengths. This extremely broadband monopole uses a deterministic Koch motif to the 4th iteration (Patent Pending).*





*Contrary to this illustration in **New Scientist**, soldiers will not have a Minkowski fractal molded into their helmets. Chip Cohen corrects the record in the sidebar story.*

new antennas are set to be used in everything from mobile phones to huge receiving arrays, physicists are being left behind. Nobody is exactly sure why fractals make such good antennas. Now the race is on to find out.

### Strike a chord

Antennas work rather like the strings of a piano. When struck, a piano string vibrates at a specific wavelength. Because the ends of the string are fixed and cannot move, the wavelength must be some multiple of this distance. The simplest resonance will have a wavelength that is twice the length of the string. A similar effect occurs when a conducting wire is "struck" by radio waves. The waves induce a variable current along the length of the wire, and since this current must be zero at the ends, the wavelength of any current fluctuations can only be some multiple of the wire's length. And the longer the wavelength, the longer the antenna must be to receive it.

In practice, the range of frequencies an antenna can broadcast and receive can be varied by changing the electrical properties of the circuits to which it is connected. Looping the antennas or adding small perpendicular wires to it also changes properties such as its capacitance and inductance. It is even possible to predict the performance of certain shapes using equations that describe the electromagnetic behavior of materials.

Those equations were developed in the 1980s by James Clerk Maxwell. "You can solve Maxwell's equations fairly straightforwardly for uniform curvilinear antennas — that is, things like loops — or straight wires," says Cohen, who is now chief technical of

## Fractal Antenna Twists and Turns

By Nathan "Chip" Cohen, Ph.D.

Boston University and Fractal Antenna Systems, Inc.

In 1988, I set off on an entertaining and educational effort to build antenna elements using self similar "fractal" shapes. But I kept it private. As a radio astronomer with a Cornell doctorate I knew this was one of those activities one dared not tell one's colleagues — too strange. It could be perceived in the same vein as coat hanger car antennas and broken, twisted TV rabbit ears.

In my first efforts, I built fractal antennae for my 2 meter rig in my studio apartment. Pressed for time and resources, it remained a personal and modest past time for many years. As the data got better in quality and quantity I knew I had to eventually write it up. And by 1994 I braved the waters and submitted to a well-known ham journal.

It was turned down as an April Fool's joke. In February no less.

That bizarre rejection set the tenor for some of the last years' less meaningful moments, putting out fires that never should have started. The adjacent article by Michael May is a major case in point. First published in *New Scientist*, this is an intriguing depiction of fractal antennas. But after it came out, odd things began to happen: I got vicious e-mail; usenet posts self-righteously talked about fraud; colleagues would make excuses to skip lunch dates. I felt like I was wearing a scarlet A for "Antenna."

After reading the article I knew what had happened: this was a different version from the one I fact-checked, no doubt edited for publication. This editing pass made some errors — in part combining phrases which then over-generalized the meaning — that, justifiably, offended the tastes of the antenna gurus. So let's set the record straight:

- 1) A fractal antenna is a small resonant antenna which, when used to shrink two to four times, provides very good efficiency. *But it will not produce a high performance, very tiny antenna. So don't expect 10 dBi on 80 M with a fractal 2 feet high.*
- 2) Fractal antennas can provide gain, small size, and broad bandwidth. *But they will not provide all three at the same time.*
- 3) Fractals are naturally very broad bandwidth devices. *But this ultrawide bandwidth happens at the higher frequencies, where the antenna is electrically large.*
- 4) Soldiers do not walk around with the Minkowski pattern on their helmets, contrary to the *New Scientist* illustration. I didn't say this. The pictures and graphics I provided *New Scientist* were not used.

Fractal antennas have recently — as just published in the journal *Fractals* — resolved a 42 year puzzle and redefined what makes up a frequency independent antenna. Self similarity ends up being one of the two geometric requirements for frequency independence. Log periodics are fractal antennas and they meet both requirements. But other fractal designs have the same frequency independent qualities and they don't look like log periodics. Frequency independent antennas enter a new era.

I note that not everyone was thrown off by this article. Pat, G3VA, in his "Technical Topics" column, initially was critical of the *New Scientist* material (*RadCom*, April 1998) but afterwards went and read my articles. He did a major turn-around (*RadCom*, June 1998). So despite the April issue you are now reading, this is not an April Fool's joke.

What does all this mean? In practice, it means that at least some of your future antennas will use fractals. You might not want to build a 160 M fractal curtain, but chances are you'll see fractal designs at HF, and most certainly at VHF and higher. I've helped this along by writing almost a dozen articles for hams and experimenters. I've also set up a ham page on the Hyperlink <http://www.fractenna.com> URL, which includes my tiny 10 M fractal quad Yagi (see the figure in the second sidebar) and other fractal designs to experiment with.

Now it's your turn: here is a wonderful opportunity for hams and hobbyists to experiment, mostly in cheap, bent wire, with a state of the art technology, initially — and proudly — ham-grown.

ficer of Fractal Antenna Systems in Fort Lauderdale, Florida, and a professor at Boston University. The challenge is to come up with a way of solving Maxwell's equations for fractal patterns. Nobody has yet succeeded.

Making fractals is not difficult. A fractal "grows" through a series of steps, or iterations. A Minkowski box fractal, for example, begins as a straight line. The first iteration adds a box with its base removed to the middle of the line to create a shape like a square wave. The second iteration repeats this process in the middle of every straight line in the shape. This adds a further five smaller boxes. The third iteration repeats this process again, and so on ad infinitum (see diagram). Making a fractal antenna requires a single wire that is bent many times to make the required shape. This mending makes the wire much more compact.

Despite the tradition of using simple shapes for antennas, Cohen returned to the idea of fractal antennas in the 1990s. Starting with a straight-wire antenna, he tested its "gain," which is a measure of how well it transmits a signal in a beam. Then he bent it into the first iteration of a Minkowski box fractal — the square-wave shape. The gain increased by four decibels. Since the decibel scale is logarithmic, says, Cohen, that's a substantial amount of gain. "But that wasn't too much of a surprise. People had added stubs to anten-

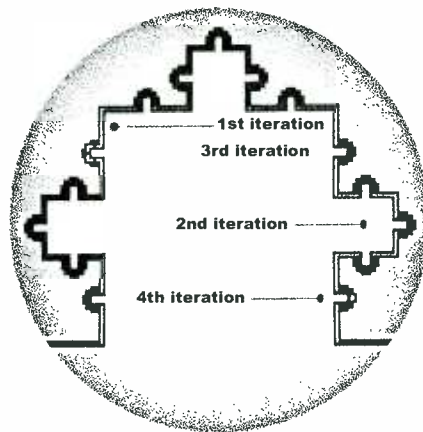

nas like that before."

The big surprise came when Cohen added the second and third iterations. To his amazement, the gain remained the same as that for the square-wave shape, even though the antenna became more compact.

A fractal antenna's resonance — the wavelengths to which it responds — also change as iterations are added. And in a way that is hard to explain. Researchers believe that a number of processes are at work. The iterations add smaller line segments to the fractal, and each of these can act like an individual antenna that responds to shorter wavelengths. In addition, the iterations add bends to the antenna, and this changes its capacitance and inductance. This process is called fractal load-

ing and the result is that the antenna resonates at both shorter and longer wavelength signals. Because of this, the range over which the antenna can receive signals — its bandwidth — grows.

While increasing the number of iterations makes the antennas smaller without reducing gain, there is a practical limit to how small they can get. This is because the diameter of the wire must also get smaller to accommodate the tiny bends. Smaller wires have higher electrical resistances, making them less efficient at picking up and sending radio signals. "There are certainly diminishing returns — on most antennas — for iterations above, I'd say, five or six," says Cohen.

### Maxwell's dilemma

Higher-order iterations create problems for physicists, too. Calculating an antenna's performance with Maxwell's equations depends on the distribution of electrical current along it. For simple shapes, like lines and loops, the equations can be easily solved. But no solutions exist for most fractals, and scientists must use what are known as numerical approaches to find the current distribution.

Numerical methods are far from perfect because they make assumptions about the way the antenna works. One way of doing this is to assume that each segment operates as an independent straight-line antenna. "You divide the antenna up, and you find the cur-

### What is a fractal?

A fractal is a rough or fragmented geometric shape that can be subdivided in parts, each of which is (at least approximately) a reduced-size copy of the whole. Fractals are generally self-similar and independent of scale.

There are many mathematical structures that are fractals. Fractals also describe many real-world objects, such as clouds, mountains, coastlines, roots, branches of trees, blood vessels, and lungs of animals, that do not correspond to simple geometric shapes.

Benoit B. Mandelbrot invented the word: "I coined fractal from the Latin adjective *fractus*. The corresponding Latin verb *frangere* means 'to break': to create irregular fragments."

These mathematical constructs provide the basis for new art forms like this Mandelbrot fractal, helped develop digital compression techniques for moving images, and apparently have practical applications beyond what we can even guess.

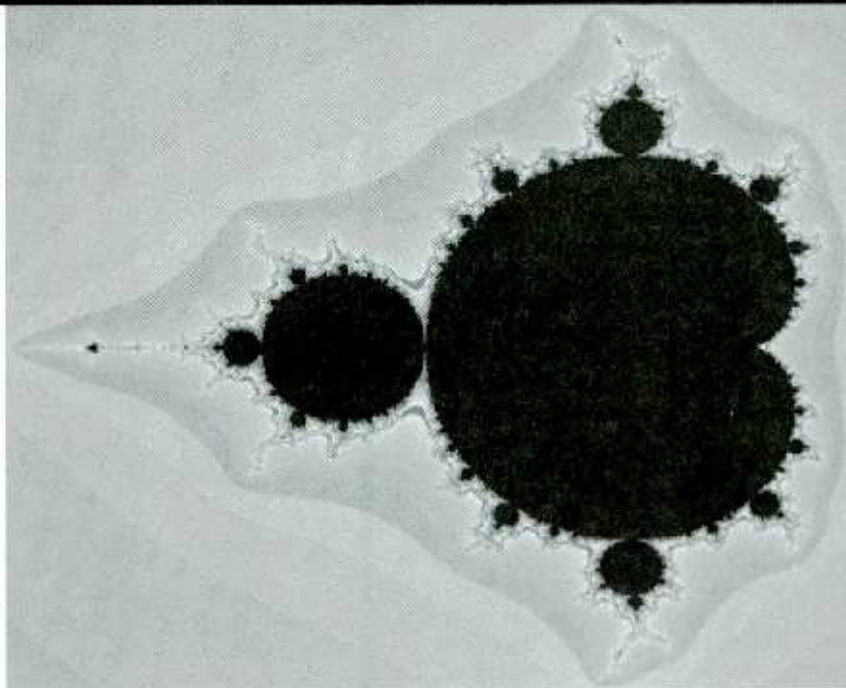



## Build a record-breaking 10 meter antenna

In December 1998, a fractal design application in the form of a small beam antenna was put to the test by Dr. Nathan Cohen, N1IR, who is also a radio astronomer and assiduous radio amateur (see his sidebar clarification to Mike May's feature article). Using the fractal Yagi on top of a short tower, he made thousands of radio contacts all over the world from the company's facilities in Massachusetts.

The small fractal antenna made contact on 10 meters with dozens of stations in Europe using only 1 watt. Contacts with stations in Palau, Papua, and many other exotic Pacific locations were accomplished successfully with only 2 watts. (For comparison, typical cell phones use about one watt of power to accomplish local transmissions to cell sites.)

This patent pending design is available to experimenters from the Fractal Antenna Systems' website at [www.fractenna.com](http://www.fractenna.com). Hobbyists interested in learning more and experimenting with fractal antennas are invited to an email reflector set up specifically for such discussions at [www.onelist.com](http://www.onelist.com). Search on "fractal antenna" and follow the instructions. Posts are made via [fractalantenna@onelist.com](mailto:fractalantenna@onelist.com).

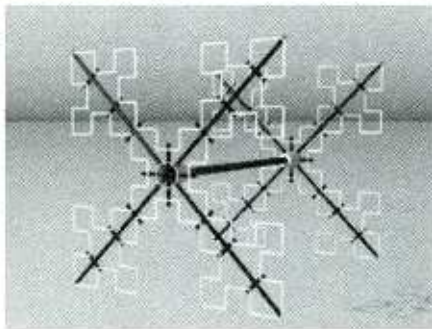

*A graphic rendering of the fractal quad (patent pending to Fractal Antenna Systems, Inc.), courtesy of WB8RCR.*

rent on each length," explains Dwight Jaggard, an electrical engineer at the University of Pennsylvania.

This approach works well for a few iterations, but higher-order iterations contain large numbers of segments that vary in size over many orders of magnitude. The numerical techniques simply cannot cope.

Just how this can be solved is not clear, but Doug Werner, a mathematician at Pennsylvania State University, has some ideas. "You might be able to take advantage of the scaling in some clever way to avoid doing the numerical computations at every scale," he says. It is possible that the first few iterations could reveal a pattern that can be applied to additional iterations. But so far no such methods exist and the performance of many fractal antennas can only be assessed after they have been built.

### Large cigars

While some researchers continue to improve their numerical methods, others are

attempting to incorporate fractal antennas in real devices. In the near future, says Cohen, fractal antennas will be used inside cellular and cordless phones, replacing the conventional wands. Fractal Antenna Systems has developed the "fractal micropatch," which is smaller than a 35-millimeter slide and about as thick. It can simply be stuck inside the casing of a phone. Previously, the smallest antenna that could work inside a cellular phone was the size of a large cigar.

In a year or two, says Cohen, "you will see fractal antennas as part of wireless devices in things like electricity meters and vending machines." These devices will communicate through cellular phone lines to report meter readings or the need for restocking. Small antennas could even reduce the bulk of equipment carried by military radio operators in the field. Soldiers of the future might even keep in touch with their operational base through fractal antennas built into their helmets.

These little devices, dreamt up to beat an antenna ban, look set to revolutionize the design of radio transmitters and receivers. Perhaps one day they could do the same for the leases on apartments in Boston.

.....  
*Mike May is an associate editor of the magazine American Scientist. This article is reprinted with permission from the British magazine, New Scientist.*



High Performance Cell Subscriber Fractal Micropatch® Mark I. Patent Pending

# STOP! LOOK & Listen to This!

**Alinco DJ-X10T – We've reinvented the multichannel receiver!**

- 1200 memories plus two VFOs
- 100 KHz – 2 GHz coverage\*
- WFM, NFM, AM, USB, LSB and CW modes
- Alphanumeric channel designations – up to 3 lines
- Multi-function Channel Scope™ display
- Internal "help" function
- PC programmable
- Beginner and Expert operating modes
- Automatic Memory Write Feature
- Auto timer on/off, internal clock
- Backlit display and keys



**The Alinco DJ-S46 FRS radio will have YOU talking!**



- NO License Needed
- Up to 2 mile range\*\*
- 14 Channels
- FM Transmit/Receive
- NiCd, Alkaline or External Power
- Long Battery Life
- Self Storing Antenna
- Compact Size
- Simple Operation
- Lighted Display
- Accessory Ports
- Compatible with other FRS radios

Visit our web site!

**Simple • Clean • Dependable**

**ALINCO**  
**RADIO'S VALUE LEADER™**

Dealer Inquiries Welcome

U.S.A. Alinco Branch: 438 Amapola Ave. Suite 130 • Torrance, CA 90501

Phone: (310) 618-8616 • Fax: (310) 618-8758

Internet: <http://www.alinco.com>

\*Cellular blocked. \*\*Effective operating range varies due to terrain, channel use, batteries and other conditions

Richard Barnett  
ScanMaster@aol.com

### Consumer Electronics Show 1999

There are few things in life that stir the mind like a gigantic roomful of toys. If you like gizmos, gadgets, and other cool stuff (grown-up toys as it were), then the annual Las Vegas Consumer Electronics Show is the place to be. What's your pleasure? Flat screen TVs, HDTV, AutoPC?

No? Then how about scanners?

At each Consumer Electronics Show (CES), Uniden America provides a prominent booth in the main show hall. For 1999, Uniden moved its booth to the show floor, close to the Microsoft booth. (Microsoft was showing AutoPC and Windows CE applications, their new cordless phone with PC attachment, and a few other non-software trinkets.)

A key Uniden product line, of course, is cordless phones, of which Uniden is the largest manufacturer in the world. Therefore a great portion of their booth is devoted to this seemingly essential household appliance—the latest and hottest being a cordless phone with “Long Distance Manager.” With each long distance call, a centrally located server will check its database of all the major phone companies as well as all the insufferable 10-10 providers. It will choose the best rate for the customer at the time, even basing its decision on how long the customer, on average, calls a particular number, and put the call through.

Why should a scanner column care about cordless phones? Well, for one thing, Uniden is also the world's largest manufacturer of scanners; the health of this company across all of its product lines could impact the category that interests us as well. All right, all right, so I'll tell you about the scanners!

Uniden had, perhaps, rested on its laurels a bit following the blistering success of the TrunkTracker line. Trunking systems had turned scanners and consumers off to public safety monitoring prior to 1997. TrunkTrackers have stabilized the hobby and have brought back an energy and interest in scanning, even though the gathering storm of digital is still hovering on the horizon.

Trunk tracking scanners, combined to a small extent with software such as Trunker



and TrunkTrac (the development platform for the original TrunkTracker), have for now restored the customers' faith in the hobby. The advent of the BC-235, BC-895 and their Radio Shack variants (PRO-90, PRO-91, 2050, 2066), and high-end products such as the AOR-8200 and the flexible new models from Opto, have brought the fun back into the hobby and offered the consumer a choice of products.

At this year's CES show, Uniden announced another major breakthrough in trunking technology: the ability to track GE/Ericsson analog trunked radio systems. The first model which will offer this feature will be the **BC-245XLT Trunktracker II** (or, as I call it, the “T2”) portable scanner. The unit shown was only a mock-up—a BC-235 case with a small change to the key assignments and display. The sign above the unit had words to the effect of “Trunktracking

now with G-Tracker,” which is the Uniden in-house name for the GE/Ericsson trunked system tracking technology. The unit is also designed to have “SmartScanner,” which is a very easy-to-use system for acquiring and programming your scanner over a phone line — no PC or CD-ROM required.

Before reviewing some of the anticipated features of the BC-245, it must be remembered that the radio was not yet out of its development phase at presstime. Features and capabilities may very well change prior to production. Here is just a partial new feature list, with the caveat that some of these items may not make the final cut:

- GE/Ericsson trunktracking
- VHF/UHF & 900 MHz Motorola trunktracking
- Multiple system trunktracking
- Simultaneous trunked and conventional scanning
- Status bit operation, allowing automatic reception of emergency and other calls from another talkgroup
- SmartScanner programmability
- Upgraded display backlighting
  - Railroad service search with frequency/American Association of Railroads channel “flip-flop” (Frequencies active during the rail service search will show both the frequency and the assigned channel number, similar to the way the marine service search currently works in the BC-235.)



Because the 245 will use the same case as the 235, there will be no change to the batteries and there will be no alpha capability. Uniden does hope to have the radio available by the late spring or early summer.

Other radios shown were the new **Sportcat BC-180** (triple conversion and with



standard keypad operation) and a new line of "clock-radio" scanners. These radios are small base units that will fit great on your night table, provide a clock radio, alarm, AM-FM, weather, and a 30-100 channel scanner depending on the model. This is a unique and welcome application for a scanner (night table space is at a premium).

■ **More CES News**

- Sony did not have a scanner at the show. Perhaps the company has so many product lines that they had to put a limitation on their show offerings. A Sony rep said that they did display their scanner at COMDEX and that the product is doing very well.
- RCA did not show their scanner within the main hall of the show. They may have had it at another hotel for dealers only, as they did last year.
- High-end players such as AOR have displayed at CES in the past, but they were not there this year. (It is incredibly expensive to have a booth at this show.)
- ICOM had a booth reserved but did not come! This was a shocker. Last year they showed their PCR-1000 as well as other models. This year we went looking for their booth (which was in the show directory) and found an empty slot on the show floor.
- RELM/FOX/AK America made a last-minute decision not to come to CES, reportedly because they had nothing new ready to display.
- Radio Shack never has a booth at the show.
- OptoElectronics also never has had a booth at CES, but they do show at other, more specialized, conventions.

Admittedly, these events are primarily to show off new product lines, which may explain why Uniden was alone in having scanners on display. Reaction to their new models at the show was quite good. Customers were very pleased to see a redesigned Sportcat; they liked the idea of the clock-radio scanners as a new take on the product, and they certainly were very pleased that the second major trunking format was being addressed with the 245 "T2."

■ **Connecticut State Police - When will they ever change?**

The Connecticut State Police installed their now antiquated low-band radio system in 1940. For nearly two decades the agency has been researching how to upgrade or replace the system that has so bedeviled

troopers, who claim to fight the constant battle against "dead zones."

Motorola was selected to install an 800 MHz trunked radio system for the state but there have been recent serious snags. The state is demanding extremely high coverage capabilities and Motorola, according to news reports, has countered that this will require more frequencies and more towers, and of course greater expense. Is this a dance we've seen before, from both public agencies as well as manufacturers? Stay tuned to 42 MHz, for quite a while to come!

■ **Bringing that old scanner back to life**

In this hobby of ours one of the most difficult resources to find is a scanner repair center. Scanners are such a specialized product that you would only trust your gear to someone who has been in the business for years and who understands the product. Radio and Uniden do scanner repair work, but they generally will not have the components for '70s and early '80s vintage models (it's worth checking with them, though, to see what they can do for a particular unit).

G&G Communications, owned by Gerry Oliver, has been in the business of scanner repair for probably longer than he cares to remember. Gerry purchased old parts from the manufacturers years ago and has the knowledge and components to fix most any model. The only problem with G&G is that, with their fine reputation, they are often backed-up, so be prepared to be without your scanner for some time. The new address for G&G Communications (Gerry Oliver) is 7825 Black Street Road, LeRoy, NY 14482. Only the street address was changed. Their phone number is still (716) 768-8151.

■ **A mammoth system grows some more**

We recently received the following e-mail from the Forest Hill, Texas, Fire Department. It's nice to have data direct from the horse's mouth.

Dear Sirs: Please be advised that the City of Forest Hill Texas Fire Department has joined in with the **City of Fort Worth, Texas, Public Safety System**. Please find below a list of our talkgroups.

- 19280
- 19312
- 19344
- 19376
- 19408
- 19440

- 19472
- 19504
- 19536
- 19568
- 19600
- 19632
- 19664
- 19696
- 19728

(Unfortunately no ID usage was provided.)

Roland R. "Mac" McCormick III, KF4LMT, shared the following **Savannah/Chatham County, Georgia**, (Type II SmartZone) Trunked Repeater System information. Thanks also goes to David Carter and James Brummett for their contributions to this list.

**Frequencies:**

- 860.9875, 860.9625, 860.7625,
- 860.7125, 859.9875, 859.9625,
- 859.7625, 859.7125, 859.4625,
- 858.9875, 858.9625, 858.7625,
- 858.7125, 858.4625, 857.9875,
- 857.9625, 857.7625, 857.4625,
- 856.9875, 856.9625, 856.7625,
- 856.4625, 855.9875, 855.7125,
- 855.4625, 854.9875, 859.9375,
- 858.9375, 857.9375

(There appears to be at least one too many frequencies here. The maximum for a trunking system is 28.)

There is also a site on **Tybee Island, Georgia**, that uses the following frequencies:

- 868.8875, 868.3875, 867.6875,
- 866.8875, 866.2375

Monitor what's happening in REAL TIME. Search, sort and scan by freqs, comments, hits etc. PC can even play back audio hits with the soundcard while scanning at full speed. Ascii and direct DBF file support. Tape controls, alarms, many new features. Functional demo [www.futurescanning.com](http://www.futurescanning.com) or call **RadioMax...just \$45 (includes s/h in USA)**  
 FUTURE SCANNING SYSTEMS  
 6105 SE Nowata Road #6, Bartlesville OK 74006  
 Ph. 918-335-3318 FAX 918-335-3328

## Talkgroup IDs

### County Law Enforcement

- 1616 Chatham County PD Emergency
- 1648 Chatham County PD Common
- 1680 Chatham County PD Dispatch 1
- 1712 Chatham County PD Dispatch 2
- 1744 Chatham County PD Dispatch 3
- 1776 Chatham County PD Dispatch 4
- 1808 Chatham County PD Detectives 1
- 1840 Chatham County PD Detectives 2
- 1872 Chatham County PD Detectives 3
- 1904 Chatham County Animal Control
- 2672 Chatham County SO
- 2704 Chatham County SO A3 Information
- 2768 Chatham County SO A8
- 2928 Chatham County SO K9
- 2960 Chatham County SO A5 Car to Car
- 3024 Chatham County Courthouse Security
- 4240 Westside Common
- 4304 Bloomingdale PD 1
- 4336 Bloomingdale PD 2
- 4368 Bloomingdale PD 3
- 4496 Port Wentworth PD 1
- 4528 Port Wentworth PD 2
- 4560 Port Wentworth PD 3
- 4786 Thunderbolt PD
- 4912 Garden City ?
- 4944 Garden City PD 1
- 4976 Garden City PD 2
- 5328 Pooler PD 1
- 5360 Pooler PD 2
- 6096 Savannah International Airport Police
- 6128 Savannah International Airport
- 7088 BOE Campus Police Channel 1
- 7152 BOE Campus Police Channel 3

### County Fire and EMS

- 2352 Chatham EMS Dispatch
- 2416 Med Common
- 2448 EMS Administration
- 3440 Memorial Medical Center ER
- 3472 Candler Hospital ER
- 3504 St. Joseph's Hospital ER
- 3568 Chatham Fire Dispatch
- 4592 Port Wentworth Fire
- 5040 Garden City FD

### Southside Fire and EMS

- 3248 Southside Fire and EMS Admin
- 3824 Southside Fire and EMS Dispatch
- 3856 Southside Fire and EMS Division 1/  
TAC 1
- 3888 Southside Fire and EMS Division 2/  
TAC 2
- 3920 Southside Fire and EMS Division 3/  
TAC 3
- 3952 Southside Fire and EMS Division 4/  
TAC 4
- 3984 Southside Fire and EMS Division 5/  
TAC 5
- 4112 Southside Fire and EMS Medic 1

### County EMA

- 6224 Chatham County Emergency Management CEMA 1

- 6256 Chatham County Emergency Management CEMA 2
- 6288 Chatham County Emergency Management CEMA 3
- 6320 Chatham County Emergency Management CEMA 4
- 6352 Chatham County Emergency Management CEMA 5

### County Public Works

- 3152 Chatham County Public Works Special Ops 1 (?)
- 3184 Chatham County Public Works Special Ops 2
- 3280 Chatham County Public Works
- 3312 Chatham County Public Works
- 3344 Chatham County Public Works
- 4656 Port Wentworth Public Works
- 5552 Chatham County Mosquito Control
- 5744 Chatham County Public Works - Computer Techs
- 6704 Chatham County Public Works
- 6832 Chatham County Public Works
- 6864 Chatham County Public Works
- 6960 Chatham County Building Inspectors
- 7024 Chatham County Public Works - Recreation

### Unidentified County Channels

- 3120
- 4208
- 5776
- 5840
- 5904
- 5968
- 6384
- 6448
- 6512
- 6576

### Savannah Police

- 32784 Savannah PD A1 Car-to-Car
- 32816 Savannah PD A2 Precinct 1&2 Primary
- 32823 Savannah PD "Across the Board" from A2
- 32848 Savannah PD A3 Information
- 32851 Savannah PD A3 & A6 Information Crosspatch
- 32880 Savannah PD A4 Car-to-Car
- 32912 Savannah PD A5 Precinct 3&4 Primary
- 32919 Savannah PD "Across the Board" from A5
- 32944 Savannah PD A6 Information
- 32947 Savannah PD A6 & A3 Information Crosspatch
- 33072 Savannah PD A10 CSU, Traffic, Detectives
- 33079 Savannah PD "Across the Board" from A10
- 33104 Savannah PD A11 CSU, Traffic, Detectives
- 33111 Savannah PD "Across the Board" from A11
- 33136 Savannah PD A12 CSU, Traffic, Detectives
- 33168 Savannah PD A13

- 33175 Savannah PD "Across the Board" from A13
- 33296 Savannah PD A16 Command
- 33456 Savannah PD Common
- 33489 Savannah PD?
- 34484 Savannah PD?

### Savannah Fire and Emergency Services

- 36880 Savannah Fire and Emergency Services Dispatch
- 36887 Savannah Fire and Emergency Services Dispatch (night)
- 36912 Savannah Fire and Emergency Services
- 36976 Savannah Fire and Emergency Services Fireground 1
- 37008 Savannah Fire and Emergency Services Fireground 2
- 37040 Savannah Fire and Emergency Services Fireground 3
- 37072 Fire Common

### City Public Works

- 49200 City of Savannah Public Works
- 49232 City of Savannah Public Works
- 49264 City of Savannah Public Works - Computers
- 49296 City of Savannah Public Works - Computers
- 49392 City of Savannah Public Works
- 49424 City of Savannah Public Works
- 49456 City of Savannah Public Works
- 49488 City of Savannah Public Works
- 49520 City of Savannah Public Works - Water Distribution
- 49552 City of Savannah Public Works
- 49584 City of Savannah Public Works - Sewer Maintenance
- 49616 City of Savannah Public Works
- 49648 City of Savannah Public Works
- 49776 City of Savannah Public Works
- 49808 City of Savannah Public Works
- 49872 City of Savannah Public Works
- 50000 City of Savannah Public Works
- 50032 City of Savannah Public Works
- 50064 City of Savannah Public Works - Park and Tree
- 50096 City of Savannah Public Works - Traffic Engineers
- 50128 City of Savannah Public Works - Cemetary
- 50160 City of Savannah Public Works - Street Maintenance
- 50192 City of Savannah Public Works
- 50224 City of Savannah Public Works
- 50256 City of Savannah Public Works
- 50320 City of Savannah Public Works
- 50352 County-Wide Common
- 50384 City of Savannah Public Works
- 50512 Traffic regarding TRS

There were reports in early February that this system went down for a time. We were unable to verify it before presstime. Any comments on this, or updates to the material above, would be appreciated.



# RELM Two-Way Radio Specials

**COMMUNICATIONS ELECTRONICS INC.**

**Be prepared. Relm two-way transceivers from CEI are year 2000 compliant.**

Communications Electronics is offering a great deal on the RELM MP series transceivers. Visit CEI on the web at [www.usascan.com](http://www.usascan.com) to see our 30th anniversary special savings. To get your free fax-on-demand catalog, dial 734-663-8888 from the telephone handset on your fax machine for instructions. Get many free benefits such as extended warranty coverage on new RELM transceivers when you use your Communications Electronics Platinum Plus Master Card® issued by MBNA. No annual fee. Call 1-800-523-7666 anytime. Mention offer Q3K1 to request yours today.

## RELM® MPV32-A or MPU32-A Transceiver Special Package Deal - Only \$299.95

Manufacturer suggested list price \$515.00/Special \$299.95

Looking for a great hand-held two-way transceiver? To celebrate our 30th anniversary, CEI has teamed up with RELM Communications to offer you our transceivers guaranteed to work in the year 2000 and beyond. With the CEI package deal, you will get your choice of VHF or UHF MP series portable transceiver, belt clip, wall charger, 700 ma rechargeable battery, antenna, and two year limited factory warranty. The CEI RELM package deal is only \$299.95 plus \$19.00 shipping. You'll save over \$215 off the regular retail price when you order now! Firefighters and rescue workers depend on the RELM MPV32 transceiver for direct two-way communications with their fire or police department, civil defense agency or ham radio repeater. The MPV32 is our most popular programmable frequency agile five watt, 32 channel handheld transceiver that has built-in CTCSS, which may be programmed for any 50 standard EIA tones. Frequency range 136.000 to 174.000 MHz.

UHF range 450-480 MHz. The full function, DTMF compatible keypad also allows for DTMF Encode/Decode and programmable ANI. Weighing only 15.5 oz., it features programmable synthesized frequencies either simplex or half duplex in 2.5 KHz. increments. Other features include PC programming and cloning capabilities, scan list, priority channel, selectable scan delay, selectable 5 watt/1 watt power levels, liquid crystal display, time-out timer and much more. When you order the MPV32 from CEI, you'll get an antenna, 700 ma rechargeable battery,

add \$20.00 to substitute a 1000 ma battery), battery charger, belt clip and user operating instructions. Other useful accessories are available. A heavy duty leather carrying case with swivel belt loop part #LCMP is \$49.95; rapid charge battery charger, part #BCMP is \$69.95; speaker/microphone, part #SMMP is \$54.95; extra high capacity 1000 ma. ni-cad battery pack, part #BPMP1 is \$79.95; extra 700 ma. ni-cad battery pack, part #BPMP7 is \$59.95; cloning cable, part #CCMP is \$34.95; PC programming kit, part #PCKIT030 is \$224.95. Your RELM radio transceiver is ideal for many different applications since it can be programmed with just a screwdriver and programming instructions in less than 10 minutes. Programming is even faster with the optional PC kit. The programming instructions part #PIMPV is \$19.00. To order this special RELM deal, call CEI at 1-800-USA-SCAN or visit our web site at <http://www.usascan.com>.



## TrunkTracking Radio

DISTRIBUTOR'S COUPON EXPIRES 05/31/99 #9904M8

### SAVE \$125 on one BC895XLT

Save \$125 when you purchase your Bearcat 895XLT scanner directly from Communications Electronics Inc., PO Box 1045, Ann Arbor MI 48106 USA. Telephone orders accepted. Call 1-800-USA-SCAN. Mention offer CEI8. TERMS: Good only in USA & Canada. Only one coupon is redeemable per purchase and only on specified product.

#### Bearcat®895XLT-A Radio Scanner

Mfg. suggested list price \$729.95/Special \$319.95  
300 Channels • 10 banks • Built-in CTCSS • S Meter  
Size: 10-1/2" Wide x 7-1/2" Deep x 3-3/8" High  
Frequency Coverage: 29,000-54,000 MHz., 108,000-174 MHz., 216,000-512,000 MHz., 806,000-823,995 MHz., 849.0125-868,995 MHz., 894.0125-956,000 MHz.

The Bearcat 895XLT is superb for intercepting trunked communications transmissions (see BC235XLT description below) with features like TurboScan™ to search VHF channels at 100 steps per second. This base and mobile scanner is also ideal for intelligence professionals because it has a Signal Strength Meter, RS232C Port to allow computer-control of your scanner via optional hardware and 30 trunking channel indicator annunciators to show you real-time trunking activity for an entire trunking system. Other features include *Auto Store* - Automatically stores all active frequencies within the specified bank(s). *Auto Recording* - This feature lets you record channel activity from the scanner onto a tape recorder. *CTCSS Tone Board* (Continuous Tone Control Squelch System) which allows the squelch to be broken during scanning only when a correct CTCSS tone is received. For maximum scanning enjoyment, order the following optional accessories: P5001 Cigarette lighter power cord for temporary operation from your vehicle's cigarette lighter \$14.95; P5002 DC power cord - enables permanent operation from your vehicle's fuse box \$14.95; MB001 Mobile mounting bracket \$14.95; EX711 External speaker with mounting bracket & 10 feet of cable with plug attached \$19.95. The BC895XLT comes with AC adapter, telescopic antenna, owner's manual and one year limited Uniden warranty. Order from CEI today. Call 1-800-USA-SCAN.

DISTRIBUTOR'S COUPON EXPIRES 05/31/99 #9904M2

### SAVE \$100 on one BC235XLT

Save \$100 when you purchase your Bearcat 235XLT handheld scanner directly from Communications Electronics Inc., PO Box 1045, Ann Arbor MI 48106 USA. Telephone orders accepted. Call 1-800-USA-SCAN. Mention offer CEI2. TERMS: Good only in USA & Canada. Only one coupon is redeemable per purchase and only on specified product.

#### Bearcat®235XLT-A TrunkTracker

Mfg. suggested list price \$429.95/CEI price \$269.95  
300 Channels • 10 banks • Trunk Scan and Scan Lists  
Trunk Lockout • Trunk Delays • Extra battery & charger  
10 Priority Channels • Programmed Service Search  
Size: 2-1/2" Wide x 1-3/4" Deep x 6" High  
Frequency Coverage:

29,000-54,000 MHz., 108-174 MHz., 406-512 MHz., 806-823,995 MHz., 849.0125-868,995 MHz., 894.0125-956,000 MHz.

The Bearcat TrunkTracker BC235XLT, is the world's first scanner capable of tracking a selected radio transmission as it moves across a trunked radio system. Now it's easy to monitor fleets and subfleets in analog trunked radio systems. The BC235XLT can also work as a conventional scanner. This 300-channel, programmable handheld scanner provides scanner users with uninterrupted monitoring capabilities of Type I, II, III and hybrid trunking systems. Now it's easy to continuously monitor conversations even though the message is switching frequencies. The BC235XLT comes with AC adapter, CRX120 battery charger, two rechargeable long life ni-cad battery packs, belt clip, flexible rubber antenna, earphone, owner's manual and one year limited Uniden warranty. The BC235XLT when ordered from CEI now features built-in attenuator feature. Not compatible with AGEIS, ASTRO, EDACS, ESAS and LTR systems. Call CEI at 1-800-USA-SCAN to order your Bearcat TrunkTracker now.



## Radio Scanners

Monitor fire, police, weather, marine, medical, aircraft and other transmissions with your radio scanner from CEI.

AOR 5000+3G-A Desk Receiver/Government orders only \$1,949.95  
AOR 8200B-A wideband handheld scanner ..... \$519.95  
Bearcat 9000XLT-A 500 channel base/mobile scanner ..... \$344.95  
Bearcat 3000XLT-A 300 channel handheld scanner ..... \$329.95  
Bearcat 895XLT-A 300 ch. TrunkTracker base scanner ..... \$319.95  
Bearcat 760XLT-A 100 channel base/mobile scanner ..... \$179.95  
Bearcat 235XLT-A 300 channel TrunkTracker scanner ..... \$269.95  
Sportcat 150-A 100 channel handheld with 800 MHz. .... \$144.95  
Bearcat 148XLT-A 20 channel weather alert base scanner .. \$79.95  
Bearcat 80XLT-A2 50 channel handheld scanner ..... \$109.95  
Bearcat 60XLT-A 30 channel handheld scanner ..... \$79.95  
Bearcat BCT12-A2 information mobile scanner ..... \$144.95  
Bearcat BCT7-A information mobile scanner ..... \$149.95  
ICOM PCR1000-A computer communications scanner ..... \$474.95  
ICOM R10 handheld wideband communications receiver ... \$399.95  
RELM RMV60B 60 Watt 45 channel VHF transceiver ..... \$549.95  
RELM SMV4099 45 Watt 99 channel VHF transceiver ..... \$349.95

## RELM RH256N-A Wideband Transceiver

Mfg. suggested list price \$460.00/Special \$284.95

Size: 6-1/2" Wide x 10-3/4" Deep x 2-3/4" High

Frequency Coverage: 144,000-174,000 MHz.

Now...all two-way radio users can have their own RELM two-way transceiver and stay in touch with their office. The RELM RH256N is a powerful 25 Watt wideband scanning transceiver used by thousands of police and fire departments. The RH256N is programmable for up to sixteen different frequencies with selectable CTCSS tones on each channel. Also includes simplex and repeater capability, scan delay and time-out timer. Built-in priority scanner is selectable from the slope-front panel. When you order the RH256N from CEI, you'll get a complete package deal including microphone, vehicle mounting bracket, DC power cords and RELM's two year limited warranty. You can also use the RH256N as a base station if you order our 22 amp 12 Volt DC power supply part #PS26K for \$94.95 and \$25.00 shipping. VHF transmitting antenna with PL259 connector part #ANTK is \$29.95. Programming instructions part #PI256 is \$19.00.



## Buy with confidence

It's easy to order from us. Mail orders to: Communications Electronics Inc., P.O. Box 1045, Ann Arbor, Michigan 48106 USA. Add \$19.00 per weather station or radio product for UPS ground shipping, handling and insurance to the continental USA unless otherwise stated. Add \$12.00 shipping for all accessories and publications. Add \$12.00 shipping per antenna. For Canada, Puerto Rico, Hawaii, Alaska, Guam, P.O. Box or APO/FPO delivery, shipping charges are two times continental US rates. Michigan residents add state sales tax. No COD's. Satisfaction guaranteed or return item in unused condition in original packaging within 61 days for refund, less shipping charges. 10% surcharge for net 10 billing to qualified accounts. All sales are subject to availability, acceptance and verification. Prices, terms and specifications are subject to change without notice. We welcome your Discover, Visa, American Express, MasterCard, IMPAC or Eurocard. Call anytime 1-800-USA-SCAN or 800-872-7226 to order toll-free. Call 734-996-8888 if outside Canada or the USA. FAX anytime, dial 734-663-8888. Dealer and international inquiries invited. Order from Communications Electronics Inc. today.

Price schedule effective April 1, 1999 AD #040199MKT ©1999 Communications Electronics Inc.

**For credit card orders call 1-800-USA-SCAN**

**Communications Electronics Inc. Emergency Operations Center e-mail: [cei@usascan.com](mailto:cei@usascan.com)**

**www.usascan.com**  
PO Box 1045, Ann Arbor, Michigan 48106-1045 USA  
For information call 734-996-8888 or FAX 734-663-8888

# Sunspots: Stand by for Action

**W**hen I first got into shortwave utility listening at some ridiculously young age, I really wondered why receiver manufacturers bothered to put in any frequencies above 21 megahertz (MHz). Sure, I knew that high frequency (HF), went all the way to 30, but I never seemed to hear anything there. Finally, I decided that they just liked to advertise wideband equipment.

Then the solar cycle, which had been in the doldrums, went into its active mode. Before long, most of the best DX (listening at a great distance, which can be either geographical or psychological) was actually *above* 21 MHz. And now, in 1999, this is about to happen again.

Already, we're hearing utility stations that haven't been logged in several years. Most notable are the US broadcast auxiliaries in their FM (frequency modulation) allocation from 25,870 to 26,470 kilohertz (kHz). This band has become popular with talk stations who need undelayed program feeds to news and traffic reporters in the field, or for audio feeds in general. WFLA, a Florida talker on 970 kHz AM (amplitude modulation), is now being reported worldwide on 25,870 FM. The Voice of America would like to get this kind of coverage from one little transmitter!

Well, solar peaks are like this. Anything can, and usually does, happen. If it's strange now, just wait until optimum traffic frequencies on some paths go clear into VHF. The surprises have just begun.

### ■ Solar Cycles

Everyone's heard of "sunspots" and how they come and go every eleven years. They've been observed for centuries. We're in cycle 23, as they count these things, and the peak is expected in late 2000 or early 2001. Now, here's the kind of millennium celebration we like!

Radio propagation is anything that gets the wattage to your cottage, but for us it's mostly from the ionosphere's "F" region. Since the space shuttle orbits right in this charged layer, around 250 miles up, we've all seen it on television. More accurately, though, we haven't seen it: There's not

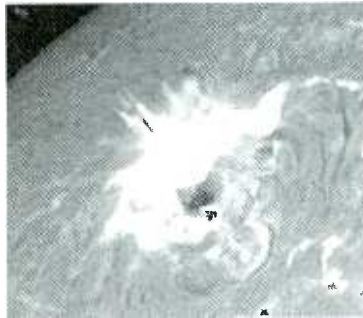

much there. What's really astounding about HF is how most of what we hear depends on gases so thin that only instruments can tell them from a vacuum.

In fact, this region is so thin that free electrons can last a long time, by electron standards anyway, until recaptured by another ionized atom. In this interval, they're available for radio wave propagation. More sunspots mean more extreme ultraviolet from the sun, more ionization, more free electrons, and better signals. Especially on hobby-grade equipment, this can very easily turn an uncopyable mumble into a voice that jumps right out of the speaker.

Of, course, too much of a good thing can alter the ionosphere in ways that are very bad for HF. Thus solar peaks are one of those good news/bad news things. When it's good, it's awesome. When it's bad, go fishing.

### ■ Geoalert?

Solar peak listening is a bit like hunting. You need to be in the right place at the right time. Just as some people study the migra-



tion routes of ducks, we study the habits of electrons. One of the best weapons in our arsenal is WWV's little "Geoalert" bulletin.

The Geoalert, which stands for "Geophysical Alert," is on the standard time and frequency station WWV, Colorado, at 18 minutes after every hour. It's also on WWVH, Hawaii, beaming out toward the Pacific, at 45 minutes past the hour. WWV uses 2.5, 5, 10, 15, and 20 megahertz (MHz). WWVH is the same, minus the 20 MHz. For our purposes, "WWV" means both stations.

Like all WWV bulletins, the length is limited to 45 seconds, so they talk fast. A typical one goes something like:

"Solar-terrestrial indices for 25 January follow. Solar flux, 138, and Boulder A index, 7. The Boulder K index at zero hours Universal Time on 26 January was one, repeat, one. Solar-terrestrial conditions for the last 24 hours follow. Solar activity was moderate. The geomagnetic field was quiet to unsettled. The forecast for the next 24 hours follows. Solar activity will be low to moderate. The geomagnetic field will be quiet to unsettled."

Huh? If you're new to this, I can't blame you for thinking it's gibberish. I certainly used to, until I read up on it. Now I'm such a WWV addict that I get every single Geoalert by e-mail. That's one every 3 hours. That's eight per day, 56 a week, 2000 a year, forever. Ahhh, heaven.

### ■ Decoding the Numbers

The amount of astrophysical knowledge conveyed in these 45 seconds would fill books. Here's the short version:

Solar flux is a fancy name for microwave radio noise from excited hydrogen around sunspots. It's measured daily, preferably at local solar noon, in tiny fractions of a watt per square meter called "solar flux units." It never goes much lower than 65 solar flux units, meaning no sunspots at all, or much higher than 327, the peak in the last cycle. We like it between 90 and 250, give or take a few solar flux units for the time of year.

The A and K indices are fancy names for how much the Earth's magnetic field has moved in the past 24 and 3 hours, respec-



**Table 1: WWV Geomagnetic Field Ranges**

Name	A-index	Typical K-indices
Quiet	0 - 8	0 - 2
Unsettled	8 - 16	2 - 3
Active	16 - 30	4
Minor storm	30 - 50	5
Major storm	50 - 100	6 - 7
Severe storm	100 - ?	8 - 9

tively, as measured in Boulder, CO. Now, who wants to know that? Only power and phone companies, pipeline operators, satellite controllers, scientists, and HF radio users. Geomagnetic data has been collected, massaged, scaled, smoothed, regressed, and generally more fussed over than any other numbers, except maybe stock market prices.

The K index is actually the more timely of the two, being three hours old at most. It uses a rather odd whole-number scale from 0 — no fluctuation at all, to 9 — a very severe “magnetic storm” condition that can affect every system on this planet. The day’s eight K indices are rescaled into the more linear A, which ranges from zero into the hundreds. See Table 1 for WWV’s geomagnetic field ranges.

For us, the A and K indices indirectly measure aurora. This vast electric current, streaming towards the polar regions, increases greatly with any solar particle ejection. It’s a major cause of geomagnetic storms, and it also tears up HF signals like nobody’s business.

The first audible effect is a fast signal flutter. This can turn into a smeary, rather Doppleresque gurgle resembling psychedelic music. Signals also weaken, then go away. Such deterioration is always present in the polar regions, but it worsens and moves steadily down toward the equator as the “storm” progresses.

To sum all this up, higher solar fluxes are better (for higher frequencies), up to a point. Lower A and K indices are always better, period. However, they interact. Propagation forecasters always balance off the previous day’s solar flux with its A index.

Solar flux below 80 or 90 means mediocre reception, except on lower frequencies. We’re averaging well over 100 now, so this is not a problem. Any sustained increase over this level is very good for higher HF propagation, especially in fall and winter, provided the A and K stay low. If they don’t, it’s nature’s way of telling you to go fishing.

Following these three numbers come the observations and forecasts. “Solar activity” is the number and size of flares. WWV’s

ranges of solar activity are very low, low, moderate, high, and very high.

Solar flares are eruptive events that occur around sunspots when their twisted magnetic fields explode. Were the Earth anywhere near one of these, it would be instant toast. At our distance, though, we get X-ray bursts and occasional streams of protons. These are mostly a hazard to satellites.

Large flares, the huge X-ray emitters, become far more common in solar peaks. These X-rays reach us at the same time we see the flare, and instantly thicken the daylight ionosphere, causing it to absorb signals. Most of the time, this effect is barely perceptible, but in extreme cases HF will instantly go away, noise and all, for up to an hour. This is a very unsettling effect to hear. To simulate it, go turn your radio off. It’s that quiet!

Flares also create radio bursts that can unrealistically inflate the solar flux. In January, we got a daily flux over 280, but it didn’t really count. Usually if the daily flux is something ridiculous like 900 they’ll correct it before we even see it, but other times they wait until later in the day. In the January case, the real thing finally turned out to be

more like 170, which is still pretty good.

We’ve already talked about the “geomagnetic field.” The voice ranges are based directly on the A and K indices, and go from quiet through unsettled to active, and finally into the “storm” levels. A list of these ranges appears at the end of this column.

Finally, WWV leaves a few seconds at the end where astronomers can drop in warnings of any solar happenings that we might want to know about. These include flares, proton events, and polar cap absorption of signals. In January of most years, you’ll also hear “stratwarm alerts.” This stands for “stratospheric warming,” an unexplained, winter phenomenon over Siberia, with some poorly understood effects on climate and radio.

The solar and magnetic readings of the Geoalert have the greatest effect in the Northern Hemisphere’s autumn. Due to the Earth’s position in October and November, good numbers can really do some spectacular things. Skip frequencies can go well into VHF.

Well, folks, have a good hunt!

**Table 2: Some 11-Meter Utilities**

kHz	Mode	Station or Program Heard
25870.0	FM	WFLA, Tampa, FL
25910.0	FM	WJFP-FM, Fort Pierce, FL
25950.0	FM	Several US broadcast stations
26100.0	FM	Several US broadcast stations
26105.5	RTTY	WLO, CW ID and ARQ idle
26110.0	FM	WLW, Cincinnati, OH
26121.0	DSC	Maritime Digital Selective Calling
26121.5	DSC	Maritime Digital Selective Calling
26122.0	DSC	Maritime Digital Selective Calling
26123.0	CW	WLO, Mobile Radio, AL
26123.8	CW	CLA, Havana Radio, Cuba
26150.0	FM	Several US broadcast stations
26200.0	FM	WSTP-TV, St. Petersburg, FL
26250.0	FM	Several US broadcast stations
26300.0	FM	Several US broadcast stations
26350.0	FM	Several US broadcast stations
26380.0	FM	WNDU-TV, South Bend, IN
26400.0	FM	Several US broadcast stations
26450.0	FM	Several US broadcast stations
26470.0	FM	WJFP, Ft. Pierce, FL
26617.0	USB	Civil Air Patrol
26620.0	USB	Civil Air Patrol

**Products that make the difference!**

\*\*\*

**High Performance MW Loop Antenna**

Award winning antenna. Tunes 530 to 1700 kHz with features unlike any other antenna including regeneration and 3 to 1 gear reduction drive!

**Pocket Loop Antenna + PRM**

Air-core loop antenna that collapses to fit in your pocket. Ideal for portables and travelers. Tunes 530 kHz to 23 MHz. The PRM (P.L. accessory) provides regeneration to >10 MHz.

**BCB Rejection Filter**

Ideal filter to eliminate BCB interference.

**Shortwave Preamp**

Extremely low noise and high immunity to overload (ip3 = +34 dBm). Includes BCB rejection filter. 10 dB gain 1.75 to 30 MHz.

**Broadband Preamp**

Same high performance as the SW Preamp but without the BCB rejection filter. Response: 100 kHz to 30 MHz. 10 dB gain

**Earth Monitor**

ELF receiver that receives 50 Hz to 15 kHz. Hear tweaks, whistlers, dawn chorus and other natural radio signals from planet Earth!

**IF Filters and Receiver Upgrades**

455 kHz and *now* 450 kHz IF filters! Receiver upgrades maximize performance!

**Kiwa Electronics**

612 South 14th Ave., Yakima WA 98902

 <http://www.kiwa.com> (full catalog)  
kiwa@wolffnet.com

 509-453-5492 or 1-800-398-1146 (orders)  
FAX: 509-966-6388

### Abbreviations used in this column

AFB	Air Force Base	PACTOR	Packet Teletyping Over Radio
AM	Amplitude Modulation	RSA	Republic of South Africa
ANDVT	Advanced Narrowband Digital Voice Terminal	RTTY	Radio Teletype
CAMSPAC	Coast Guard Area Master Station, Pacific	SAM	Special Air Mission
CG	Coast Guard	SELCAL	Selective calling tones
CW	Morse code telegraphy ("Continuous Wave")	STS	Space Transportation System ("space shuttle")
FEMA	Federal Emergency Management Agency	Swed-ARQ	Variable block length Swedish teletyping scheme
MARS	Military Affiliate Radio System	UNID	Unidentified
MFA	Ministry of Foreign Affairs	UK	United Kingdom
NASA	National Aeronautics & Space Administration	US	United States
		USS	United States Ship
		VIP	Very Important Person

All transmissions are USB (upper sideband) unless otherwise indicated. All frequencies are in kHz (kilohertz) and all times are UTC (Coordinated Universal Time).

- 4470.5 Unid-US Navy MARS training net, discussing RTTY procedures at 0130. (Robert C. Thompson-USA)
- 4665.0 Unid-Abnormal Mossad "numbers" callup "MIWDRC8C7," at 2218. (Larsen-Germany)
- 4742.0 Ascot 5050-Royal Air Force, UK, SELCAL check with Architect, at 0052. (Ron Perron-MD)
- 4821.0 AFA3HY-US Air Force MARS station controlling weekly Federal Highway Administration Net. Went to "F-23," 5755.5. Announced winter net time of 1530, at 1435. (Paul Bunyan-MO) *This is now called the Region 7 Federal Agencies Net. 4821 is F-14. Goes to F-23 at 1540, 7743 at 1550, and 9185 at 1555. -Hugh*
- 5140.0 Oklahoma SECURE (*State Emergency Capability Using Radio Effectively -Hugh*), weekly Wednesday net at 1606. Went to 7477 at 1608. (Bunyan-MO)
- 5142.6 US Coast Guard Group, Mayport, in search with *USS Doyle* (FFG-39), Coast Guard 1717 (HC-130), and unid CG helo, clear and ANDVT, at 0015. (Perron-MD)
- 5435.5 Andrews-US Air Force "Mystic Star" control, calling SAM 00300 (C-20H) on F-226, at 0210. (Paul Bunyan-MO)
- 5700.0 Abnormal 20-US Air Force, HI, test count at 0516. (Perron-MD)
- 6020.0 Unid-Probably US Army Corps of Engineers, with autolinking tones at 1609. (Bunyan-MO)
- 6739.0 Architect-Royal Air Force, UK, working unid aircraft who wanted his position passed to Blue Star (US Navy, Puerto Rico), at 0603. (Jeff Haverlah-TX)
- 6761.0 Raid 91-US Air Force KC-135 tanker, arranging refueling of Reach 5238, US Air Mobility Command, at 0135 (Al Stern-FL)
- 6786.0 Unid-Cuban "Cut Number Station," with 5-letter CW code groups at 1300. (Cam Castillo-Panama) (*Same people as the "Atencion" -Hugh*)
- 6825.0 FAV22-French Army, Mons-Valerien, with CW exercise at 1010. (Ary Boender-Netherlands) Cuban cut numbers, in CW at 1202. (Castillo-Panama)
- 6855.0 Unid-Cuban 5-letter CW cut numbers at 0912. Same station and format at 1224, and again on 6854.1 kHz at 1300. Also 6933 at 1236. (Castillo-Panama)
- 6983.0 Unid-Cuban "Atencion" numbers in AM at 0215. (Castillo-Panama)
- 7348.0 WGY908-FEMA region 8, Denver, CO, calling WGY957, FEMA, NE, at 1631. (Bunyan-MO)
- 7508.2 ZRO2-Pretoria Meteorological, RSA, with fax weather charts at 0638. (Bob Hall-RSA)
- 7669.9 FTD-Unknown French military, testing RTTY at 2200. (Jean-Marie Langlade-France)
- 8879.0 New York-NY Radio, NY, North Atlantic NAT-C net air traffic control with Iceland Air flight at 1701. (Perron-MD)
- 8906.0 Gander Radio-Gander, Canada, working KLM 78, North Atlantic NAT-A net, at 1809. (Perron-MD)
- 8992.0 Unid-Distorted numbers in Spanish, sounded like "Atencion" or "Spanish Lady," at 0400. (Haverlah-TX) *Interesting freq choice, right on US Air Force Global -Hugh*
- 9016.0 WAR 46-US Joint Alternate Command Post, PA, calling WAR 46 Mobile, no joy, at 1520. (Roger C. Roth-USA)
- 9120.0 Shark 22-US Air Force, Panama, working Lobo (Joint op center, Howard AFB, Panama) along with Relief 06, at 2300. (Bunyan-MO) *Probably Honduran hurricane aid -Hugh*
- 9462.0 WGY901-FEMA region 1, MA, working WGY912, FEMA Special Facility, VA, on "F-24." Stations did link-quality check and went to "F-34" (12216), at 1534. (Bunyan-MO)
- 10194.0 WGY908-FEMA region 8, working WGY957, at 1641. (Bunyan-MO)
- 10420.0 FDI8-French Air Force, Nice, France, CW marker at 1420. (Boender-Netherlands)
- 10883.0 Navy 50515-US Navy aircraft working Andrews AFB, at 2301. (Bunyan-MO)
- 11053.5 SAM 60201-US Air Force VIP aircraft, getting pro football scores from Andrews AFB on "F-891," at 1927. (Bunyan-MO)
- 11175.0 JGO 05-Unknown aircraft making phone patch to Delta Ops, who called them "Great Americans," whatever that means, at 1015. (Pedro, UK) SAM 401-US Air Force VIP flight, patch via Andrews to SAM Command, but lost circuit to higher precedence traffic at 2023. (Haverlah-TX)
- 11309.0 Santa Maria-Santa Maria Aeradio, Azores Islands, working various commercial aircraft at 1216. (Boender-Netherlands)
- 11340.0 Santa Maria, working Air France 3440, at 1822. (Boender-Netherlands)
- 11345.0 SDJ-Stockholm Radio, Sweden, selcal check with Premair flight, at 1521. (Boender-Netherlands)
- 12353.0 WCX9104-Tug *Monitor* w/position report for WPE, Jacksonville, other tugs heard too, at 1830. (Jay Steimel-AR)
- 14385.2 Unid-RTTY telex test, using several callsigns, at 1300. (Langlade-France)
- 14570.0 CIO2-Mossad, Israel, numbers in English, with weird French accent, at 14444, and different day at 1450. (Steimel-AR)
- 15088.0 CAMSPAC Point Reyes-US Coast Guard, CA, calling Straight 801, no joy, at 1801. (Bunyan-MO)
- 16107.0 Stockholm-Swedish MFA, messages to all consulates in Swed-ARQ, new frequency for this one, at 2304. (Hall-RSA)
- 16984.5 PPR-Rio de Janeiro Radio, Brazil, with RTTY weather and shipping bulletins, in either Spanish or Portuguese, at 0525. (Hall-RSA)
- 17135.0 Cutter 55, or similar sounding, probably an aerial tanker, working what sounded like Cutter 56, then back to UHF at 0335. (Bunyan-MO) *On a Russian maritime RTTY channel? I love it. -Hugh*
- 17519.0 WGY908-FEMA, working WGY912 on "F-53," at 1712. (Bunyan-MO)
- 18183.4 MPA-Algerian MFA, New York, with long message in French to Algiers and Geneva, in Coq-8 at 1300. (Bob Hall-RSA)
- 19131.0 Atlas-Drug Enforcement Agency, IA, giving Voice of America broadcast frequencies to unid aircraft. Atlas noted that he was reading them from *Monitoring Times*, at 2200. (John Maky-AR) *It's the April issue, but I swear I did not make this one up! -Hugh*
- 20198.3 Cape Radio-US Air Force, Cape Canaveral Air Force Station, FL, calling King 29, at 1714. (Bunyan-MO)
- 22555.0 UUI-Odessa Radio, Ukraine, CW marker at 1201. (Boender-Netherlands)
- 23337.0 Thule-US Air Force, Thule Air Base, Greenland, with unknown station at 1827. (Bunyan-MO)
- 25910.0 WJFP-FM program audio from religious broadcast stations in Ft. Pierce and West Palm Beach, FL, also on 26470, at 1623. (Bunyan-MO) *See Utility World for more on these broadcast simulcasts. -Hugh*





# Catch Coquelet-8 Before It's Too Late

This month's column continues our focus on increasingly complex HF digital transmission systems with a look at Coquelet-8 and its two chief users — the Ministry of Foreign Affairs (MFA) and Customs agencies of Algeria.

The reasoning behind the urgency in this month's column title is that both of these organizations have recently been heard experimenting with new and considerably more complex modes. MFA Algiers has been spotted using the Racal MSM1250 "SkyFax" modem on a number of embassy circuits, and Algerian Customs have specially modified commercial PacTOR modems. In all likelihood, as in many other recent cases, a gradual migration to the new equipment will take place sooner rather than later. First, let's take a look at each of this month's guests...

### Algeria's Diplomatic Service

MFA Algiers, or to use its ITU callsign, 7RQ20, can be heard nearly every weekday (except Fridays) and at weekends on a variety of frequencies (see Table 1) with messages to many embassies across the world.

**Table 1: Commonly logged MFA Algiers frequencies**

10993.64 10993.78 10996.37 13425.69 13428.40 16146.64 16272.40  
16273.64 16278.64 16315.40 16315.74 16316.30 16318.40 16318.50  
17411.10 17412.43 18180.65 18183.64 18421.40 18528.40 18529.35  
18754.55 18756.20 18757.27 18758.90 18761.00 18787.00 18943.68  
19028.62 19031.41 19036.44 19123.60 19141.36 23127.50

Messages, nearly always in plain text, are most often sent in French, but the ATU-80 Arabic alphabet is also used on occasions. Coquelet-8, at the higher speed of 26.67 baud is most often used, switching to 13.33 baud if the going gets tough. Messages follow a standard format and also contain a header which readily identifies both the sender and recipient of the message. Here's an example:

**Table 2: Example Algerian Embassy Dakar to MFA Algiers**

vci off dakar nr 782 le 9/11/96 a 1230z I/10  
exp ambalg dakar  
dest mae/dgac/dcee/sdvqam alger

Note the "vci off," short for "voici office" or "here is the office of." The second line contains the sender, "expediteur," and the last line, the destination.

Generally, the Algerians use dual-frequency operation on their networks. MFA Algiers broadcasts to a number of embassies on a single frequency, with embassies sending replies or return messages on a different frequency. Once the MFA completes the broadcast, embassies are asked by the MFA operator to reply from their own frequencies in turn. The MFA's operators often use nicknames to identify the remote embassies during such exchanges, e.g., "dkr dkr dkr pse qsl" when asking Dakar to confirm receipt. Most embassies use the same reply frequency when sending their confirmations or messages to Algiers.

### Algerian Customs

Our other commonly logged Coquelet-8 user is the Customs headquarters in Algiers and its various outposts across this large country. Traffic has been noted on the following frequencies:

**Table 3: Algerian Customs Frequencies**

4757.00 6911.38 7418.70 7808.62 7813.38 10011.39 10467.39  
11251.38 11527.40 13853.70 13898.65 13933.64 13934.80 13936.39

Messages are usually long lists of imports and exports at various checkpoints, or impounded goods. The procedures used in these networks are virtually identical to those in use on Algeria's diplomatic service. Here's an example header:

**Table 4: Example from Customs Office Ouargla to Oran**

zczc ctr209 qyh06 09.05.96 efb  
pp ala ctr hrf efd  
off ouargla to nr 1291 le 12/11/1995 a 16h00hl  
exp:mr.le chef de l'inspection divisionnaire des douanes a ouargla  
des:mr.le chef de l'inspection divisionnaire des douanes a oran

Note the use of the "off" keyword to identify the sender of the message. As can be determined from the "pp" line or copy list in the example of Table 4, operators at each of the 30 or so towns, whose customs offices are equipped with Coquelet-8, identify their locations with three letter abbreviations. HQ in Algiers is identified by "alg" or "dgd" (Directeur General des Douanes).

### Decoding Coquelet-8

As its name suggests, Coquelet is an MFSK (multi-frequency shift-keyed) system using eight tones. The tones are spaced by a meager 30 Hz which demands a narrow filter and a receiver capable of tuning in 10 Hz steps or better, as well as a steady tuning hand for satisfactory results.

The Wavecomm and Hoka decoders are all capable of handling Coquelet-8; in the case of the Hoka this sometimes requires the purchase of a "special" package. Decoding Coquelet-8 is relatively simple with one of these decoders. All that's required is to tune the center frequency of the decoder to the mid-point of the 4th and 5th tones, and the decoder will do the rest.

In all but a few cases, this will quickly produce French or ATU-80 Arabic text. Those that aren't decoded or produce garbage on screen are usually a rarely used Mark II version of the system, supported only by the newer Wavecomm units and the Hoka Code 30.

Coquelet-8 is also easy to identify by ear. Try one of the MFA Algiers frequencies listed, and you will soon hear the characteristic key-up, short idle, and traffic sound of the system. It goes something like daaaaaah, diddle-liddle-liddle, followed by the rhythmic, flute-like sound of the main traffic.

## Sunspot Peak Coming - Look to Higher Bands

The shortwave transmission season now designated A-99, from the last Sunday in March (or first Sunday in April when Daylight Savings Time starts, in the case of some US stations), is expected to bring lots of moves to higher bands than last year at this time, as we approach the next sunspot maximum.

Unfortunately, at our press time, few of the new schedules were yet available. Recent changes made in late winter are probably no longer relevant. Besides frequency changes, the usual one-hour timeshifts due to DST in Europe and North America on some stations, but not on others, lead to further confusion. We suggest you seek out the latest info for stations of interest to you on the internet. With more and more libraries providing free public internet access, there's little excuse any more for not using this resource!

### BBC Comes Clean on 3-Year Plan

After denying earlier leaked reports that BBC would be terminating its German service, BBC confirmed this on Feb. 10, trying to put a positive spin on the following three-year plan (gh):

BBC World Service plans to meet the broadcasting challenges of the next three years with a major investment programme in the internet, a repositioning of the English programming and the expansion of FM distribution. The following plans were announced by Chief Executive, World Service, Mark Byford:

Twelve World Service language services will be fully multimedia in both text and audio by 2002. All language services will be in real audio on the internet by 2005. Two continuous streams of English programming will be introduced — a 24 hour news stream, World Service News, and a stream of high quality general programmes called World Service Plus, both available on the internet and satellite 24 hours a day.

More FM frequencies for World Service will be sought with the aim, wherever possible, of being on FM in every capital city of the world within five years — while still maintaining a strong, core shortwave network, particularly in the least developed and politically sensitive parts of the world.

The two new streams of English programming will allow the mix of World Service programmes to be specially adapted for listeners in different parts of the world. This means that while World Service listeners on shortwave will continue to hear the present "rich mix" of news and general programmes, listeners to World Service on FM in cities such as Berlin, Prague, Amman and Nairobi will be able to hear their own specially tailored version of World Service compiled from the programmes available on both streams.

In parallel to these investments, World Service has looked hard at its existing services against the media background at the turn of the century. The following are the key changes:

The German language service will close. In the developed world, the World Service strategy is to target the cosmopolitan audience of opinion formers and decision makers, primarily through the English Service. Recent audience research shows that a quarter of opinion formers in Berlin listen to the World Service, but nine out of ten listen in English. Spending will be focused on an enhanced English service, and on broadcasting in FM in Germany in order to serve this target audience.

Shortwave coverage will be reduced in regions where this does not endanger the ability of audiences to access World Service programmes (e.g. where FM frequencies are available). Moreover, shortwave coverage will remain fully protected in areas of the world where local broadcasting arrangements could be threatened by political instability (via Dave Kenny, British DX Club)

**ANGOLA** Grey clandestine VORGAN - a Voz da Resistencia do Galo Negro - operated by UNITA resumed broadcasts in Jan as peace shattered. 0700-0900 UTC on 5950 kHz, 1200-1430 on 11830, 1900-2100 on 7100 (*Luso-Americano* via Rui Pires, Portugal, *Clandestine Radio Watch*)

**ANTARCTICA** LRA36 - Radio Nacional Arcángel San Gabriel. A new 10 kW shortwave transmitter from CCA Electronics in Atlanta, Georgia, is now going to the Antarctic Territory. With this the station will cover all Antarctic Territory with its programs and may broadcast 24 hours if necessary. The old transmitter was purchased in 1982 and could only broadcast two times a day. The new transmitter will broadcast on 6030, 11955 and 15475 kHz, and will be operated by the personnel of Base Esperanza. Currently the transmitter is in Base Marambia, and will go to Base Esperanza in the ice-breaker ship *Almirante Irizar*. Expected to start operations in Feb (Gabriel Ivan Barrera, Argentina, *Electronic DX Press*)

**AUSTRALIA** Rumor from reliable sources: Deutsche Welle, NHK, and Merlin are negotiating to lease and operate the Cox Peninsula transmitter site which Radio Australia has not been allowed to use for the past sesquiyear (Mike Bird, RN Media Network)

**BAHRAIN** Gulf News Agency (WAKH) in Arabic daily F1B 75 baud RTTY to ME/Af: 0500-1500 14764v, 9197v; 1500-2100 14764v, 4043v. Often does not start sending items until well after the nominal start, and traffic after 1500 is infrequent (BBC Monitoring)

**BRAZIL** The status of shortwave and tropical

bands in Brazil: There are currently 62 stations transmitting on SW, with two more to be installed in the states of São Paulo and Minas Gerais. Data is from the Ministry of Communications. On the tropical bands there are 78 stations, also with two more to be installed, one in Amazonas, and another in Rondonia.

The state with the greatest number of SW is São Paulo, 21 frequencies. SP also leads the tropical list with 15, while Amazonas has only 9. I wonder which two are the SW stations to be installed? In São Paulo, it may be R. 9 de Julho. Some states have SW vacancies. Ceará has two, which should be for the old Ceará Radio Clube; Maranhão has one, which should be for the old Timbiras which once used 19 meters.

On tropical bands, the number is much greater: 542 channels; the state of São Paulo alone has 60 available (Célio Romais, RGS, *radioescutas*) I assume the 542 figure includes possibility of piling up several stations on each frequency, much like mediumwave (gh)

**BULGARIA** R. Bulgaria planned to stop broadcasting in Spanish March 27 for economic reasons, according to a report on the *Cadena DX* net by Marino

Pace. We call upon everyone to send protest letters to the station in order to save this service (Jorge García Rangel, Venezuela)

**CANADA** Alan Maitland, the voice of CBC Radio's *As It Happens* for almost 20 years, 1974-1993, died Feb. 11 in Vancouver of heart failure. He was 78 (Steve Merti, Canadian Press, via Mike Cooper)

**COSTA RICA** RFPI heard announcing in

*All times UTC; All frequencies kHz; \* before hr = sign on, \* after hr = sign off; // = parallel programming; + = continuing but not monitored; 2 x freq = 2nd harmonic; A-99=summer season, Mar-Oct; [non] = Broadcast to or for the listed country, but not necessarily originating there.*



Spanish, but never in English, a postal code attached to their box number: Apartado Postal 88-6150, Santa Ana (gh)

**Continent of Media** additional times on RFPI: Tue 2000, Wed 1200, sometimes also Wed 0400, Sun 2230, Mon 0630 (gh)

**Chiapas: El Mundo Habla** was a single half-hour in Spanish on behalf of the Ejército Zapatista de Liberación Nacional broadcast by RFPI in January; it got a lot of publicity thanks to a Feb. 1 story in *Wired* by Christopher Jones. Meanwhile RFPI continued with a weekday Chiapas newscast in English at 2155, 0555 (gh)

A local community in a remote area of Costa Rica, which feels isolated, and is 20 km wide, wants to set up a SW station, since the FM band is claimed by commercial broadcasters, following the RFPI model, and RFPI has agreed to assist (James Latham, RFPI *Millennium Dreams*)

**Radio For Peace International Annual Report:** In 1998, there were 14 students, interns, and volunteers, who collectively contributed a total of 37 months of work (not including paying Institute of Progressive Communications-IPC students). Over the past 11 years, there have been several hundred volunteers.

RFPI's budget for its first year of operation in Costa Rica was only \$16,000. The 1998 budget of Earth Communications to run RFPI was \$186,093, including \$52,000 in donated goods and services. This includes the Oregon office, which is 100% volunteer. Full time salaries went to only five people.

**Technical Upgrades in 1998:** Frequency synthesizers replace crystal-controlled; once antennas are returned RFPI can change frequency quickly if necessary to avoid deliberate jamming, rather than wait 3-4 weeks for new crystals. Key components now on hand include a tube for the 10 kW transmitter in addition to one for the 30 kW. A full-power 3 hp blower and motor are on standby. Brown-outs and voltage fluctuations are a continuing problem.

**Antennas:** Four new ones were built and installed in 1998:

- For 21460 kHz - Five-element yagi at 105 feet, and directional control
- For 15050 kHz - High-gain yagi, on tallest tower, now increased to 200 feet high with addition of three tower sections
- For 6975 kHz - Four-element cubical quad just below the yagi at about 198 feet high. Very high gain. Boom is 55 feet long, 50 feet tall and wide, but not much wind resistance. Backup bi-directional curtain array to improve coverage toward the south, still under construction.

A high-speed computer was added, allowing sending and receiving programs on internet, subject to limitations of the only ISP in Costa Rica.

FM transmitter on 101.3 has a stronger signal; soon to be installed on a mountain, increasing coverage further, something much anticipated by the Spanish department.

Planned new programs in 1999 include: *Deep Ecology for the XXI Century* (a New Dimensions production); *Wisdom Radio Network* programs; *Voices of Vision*. RFPI hopes to exchange staff and training with Channel Africa.

IPC (intensive Spanish lessons and radio training) plans four sessions in 1999 in May, June, July and August; so far May has been confirmed. A minimum of four students is required for each session.

Paz the Cat, who runs the station, knocked RFPI off the air whilst chasing spiders, jumping up and down on some equipment, disconnecting several mini-disc and recording machines; and the day before had to clean her hair out of a VHS recorder where she had been sleeping.... (excerpts from *Millennium Dreams* as monitored by gh)

**CUBA** [non] Jose "Pepe" Collado, a carpenter and labor leader, has been appointed to chair the Advisory Board for Cuban Broadcasting, including R. Martí. A pep rally at Florida Int'l University gave him a pat on the back and sent the U.S. Senate the message to confirm him as soon as possible (Maria A. Morales, Miami *Herald* via Mike Cooper)

**ETHIOPIA** [non]. V. of United and Free Ethiopia, clandestine, appears to be dead; no longer heard on previous schedule or mentioned on Ethiopian National Congress website (Hans Johnson, *Cumbra* DX)

**GERMANY** DW heard promoting a news program in simple German for those learning the language, *Alltagsdeutsch*. Too bad other stations don't do likewise (Tim Hendel, AL) *DW Plus* for Feb showed this as a 20-minute weekly program on Thu 0935, repeated 4-hourly, i.e. 1335, 1735, 2135, Fri 0135, 0535 (gh)

**GREECE** In a letter of Dec 21, Dionisios Angelogiannis of ERT says he has been overloaded with work and continues to be. In his new position, he hopes to find some money to install the new VOA-donated transmitters in Avlis and Thessaloniki. It is a big installation and the substructure in Avlis is not good. New building has to be done, electrical supply has to be increased. (John Babbis, MD)

**HONDURAS** The 4930.6 station in San Pedro Sula, R. Costeña, also calls itself Ebenézer 12-20, after the biblical name (Henrik Klemetz, Sweden)

**IRAN** [non]. More on WWCR's Persian program Fri/Sat 1100-1200 on 12160: The program is IDing as "Radio International" (the English word "International" is used in the Persian ID). Reception reports are requested to BM Box 1499, London WC1N 3XX or to fax +1-416-515-6722 [Toronto,

Ontario]. The program mentions that a sister program in Kurdish is broadcast "on the same wavelength" and at the same time on Thursdays. It's hard to gauge the political flavour of the station from a quick check. The programme includes a talk on the "stupid" and "disgusting" antics of Iranian intellectuals, but doesn't appear to say what it favours for Iran's future (fewer intellectuals perhaps?). (Chris Greenway, BBC Monitoring, via *Review of International Broadcasting*)

Calls itself R. Porseh, which means Questions. In exact translation it's Radio Question International (P. Mohazzabi, *World of Radio*) The music used behind the identification of Radio Porseh is from Jethro Tull's "Thick as a Brick," a piece recorded in 1972, and occupying both sides of an LP (Frank van Gerwen, Castricum, Netherlands)

**ITALY** NEXUS-IBA, IRRS on 3985 denounces Merlin for moving RKI relay onto adjacent 3980 at 2030-2230, contrary to regulations and threatening the existence of IRRS (Alfredo Cotroneo, IRRS)

**JORDAN** Just when the world's attention was focused on Jordan at the death of King Hussein, R. Jordan replaced its English SW broadcast on 11690 kHz with Arabic. Way to go! It was, however, as usual clashing with RTTY; we wonder if the king, more a ham than a SW listener, ever tried to pick it up while in the US? (gh)

**NORWAY/GABON** Concerning the Africa No. 1 takeover of the old NRK Fredrikstad Thomson transmitter, Alfred Andersen of NRK confirmed MCM International (owner of Africa No. 1 in Gabon) paid NRK \$20,000 for the SW transmitter, including all spare parts, and the almost complete second transmitter (TR-2351) formerly used in Sweden.

Africa No. 1 will use it all as spares for their current units. All together the parts probably represent several 100,000 dollars worth if bought new from Thomson-AEG; some of the parts are even hard to find these days. In this view, the sellout at 20,000 dollars seems little. *But*, the alternative for NRK would have been a costly scrapping of the equipment.

Africa no 1, represented by their chief engineer Joseph Mougiabi, already have collected their equipment from Fredrikstad, as I understand, and they have covered all costs involved in disassembling, packing and shipping. They also hired former engineers of the station to help them with the job.

Various parts have been taken care of by the NRK Museum (for a planned museum at the NRK broadcast centre in Oslo), the NRK regional office in Fredrikstad, the Norwegian Telemuseum, and Norkring - the company responsible for transmitter operations in Norway. What is left (building and premises) are being sold to the City of Fredrikstad. A former engineer with the Fredrikstad transmitter plant has been documenting the history of the station. This on-going project was ordered by the National Archive of Norway and is paid for by NRK (Bernt Erfjord, *DX-News* via British DX Club)

Radio Norway Ceases Issuing QSLs. I have received a note dated Jan 7 from Radio Norway International advising that reception reports will no longer be verified, due to "tight economic budgets and reduction of staff." The Technical Manager Olav Grimdalen is interested in reports, even though he cannot send out QSLs and his address is: Post-og Teletilsynet, Box 524 Centrum, 0105 Oslo. One wonders whether some international broadcasting stations understand anything at all about listener feedback! (Bob Padula, *Electronic DX Press*)

**PAPUA NEW GUINEA** According to press reports, the National Broadcasting Corporation is to undergo a major revamp and become fully incorporated. The NBC's longest serving radio personality, Anton Kaut, has been appointed to head the new commercial division that will market the network and gradually move into commercial broadcasting. NBC managing director Boski Tonny said the NBC is embarking on an exercise to strengthen its transmission to the provinces with the help of the Japanese Government, while Australia is assisting with the upgrading of mediumwave transmitters.

The newspaper also commented on the failures of the commercialized "Kalang" service which, despite its early popularity with listeners, has not

## DX Listening Digest

More broadcasting information by country compiled  
by Glenn Hauser

## Review of International Broadcasting

SW Programming, opinion, equipment, satellite monitoring.

Samples \$2.50 each (outside North America US \$3 or 6 IRCs)

10 issue subscriptions \$26 in USA, or both for \$49

Glenn Hauser, Box 1684-MT, Enid, OK 73702

been the "cash cow" the government hoped for. "It is hard to see how the commercialisation of the existing Karai and remaining Kundu service stations can solve the NBC's financial problems."

The editorial bemoaned the demise of the Kundu provincial services which used to carry daily newscasts in up to six languages, with a wide range of extension programs contributed by public servants in national and provincial departments. "Education, agriculture, health, the law, business development and social issues were all covered in a stream of broadcasts emanating from each of 19 provincial stations. That invaluable information pipeline has become choked over the years by poor and unimaginative management, and the near total neglect of successive National Governments," the paper said. (Matt Francis, *Electronic DX Press*)

**PERU** 5906.8 - R. Panorama, 2350-0120. The Peruvian noted in USA and in a tip via Glenn Hauser in *Radio Enlace*-RNW is Radio Panorama from Distrito Recopampa, Provincia de Celendin, Dpto. de Cajamarca. It's a new station formed by the brothers Miguel y Segundo Delabriore (I am not sure of the surname). They have another station on 1400 kHz named La Voz de los Andes, and Miguel is manager of that, and Segundo of Radio Panorama. Slogan: *Radio Panorama la Reina de la Sintonia*. Said it was testing on 5900. Off the air at 0120, not heard in the mornings. I don't believe that Radio Panorama is a religious station (Rafael Rodriguez R., Bogotá, Colombia)

Also heard here on 5906.84 at 1105-1134, but the location is Lucmapampa, a sleepy village at altitude of 2624m (Takayuki Inoue Nozaki, Japan, *Relampago DX Logging*) Lucmapampa is a very small place, capital of Jorge Chávez district, 10 km SSE of Celendin on a spur from the main road to Cajamarca (Don Moore, IA)

R. Manantial, 5773.72, is a new station with Christian format heard at 1035-1116, tentatively from Jaen, Cajamarca, also with slogan *La Voz del Noriente Peruano*, very strong. Thanks to Henrik Klemetz for help with this (Jay Novello, NC) Name means spring or fountain as in source of water (gh)

**PUERTO RICO** AFRTS site-specific e-mail QSL received in 11 hours for e-mail report of the 6458.5 kHz outlet. They are broadcasting from the Naval Computer and Telecommunications Station, Isabela, Puerto Rico, with 10 kW. Message also said the outlet on 12689.5 comes from the Naval Computer and Telecommunications Area Master Station, Key West, FL, with 8 kW. Verie signer is Wayne E. Eternicka, Broadcast Operations Specialist, [eternicka@mediacen.navy.mil](mailto:eternicka@mediacen.navy.mil) (Rob Keeney, Overland Park KS)

Antenna in PR is a ground-based, omnidirectional wire with 30 foot diameter; in FL a 48-foot inverted cone from Boca Chica (Eternicka via Willi Passmann, *hard-core-dx*)

**ROMANIA** Radio Romania International's 1300 UTC broadcast is occasionally at listenable level but one Friday was actually around 17806.3 with heterodyne against something more accurate; //17745.0 whilst the two 19 mb frequencies, 15335 and 15390, were quite weak and fluttery. The Romanian home service on 17850 had the usual internal noise sounding like self-inflicted jamming (gh)

**SPAIN** REE debuted a new DX program, *Radio Waves*, UT Sun 0025 0125, 0525 on 6055. Said they could never take Terry Burgoyne's place (John H. Carver Jr., IN) New host is Justin Coe (Pete Costello, John Norfolk)

**SRI LANKA** Iranawila, the 13th VOA relay station, which has had more than its share of problems, is expected to be operational with at least two transmitters by June/July. They have already conducted some tests of their antennas. (Victor Goonetilleke, Sri Lanka)

**SUDAN** [non]. The Voice of Freedom and Renewal can be accessed at: <http://www.safusudan.com/broadcast/cast1.html> (Roger Tidy, UKOGBANI)

**TIMOR EAST** [non] A Voz do Timor Leste is supposed to be via R. Portugal at 1200-1400 M-F on 17740. Although there are programs in Tetum and Portuguese, also for East Timorese living in Australia, this ID is not heard, and there is no mention of the FRETILIN Resistance Movement. Valter got the program ID in Tetum, *Timor Loro Sae*. I have been told that this means Timor of the Rising Sun, a traditional name for the island (Valter Aguiar and Hans Johnson, *Cumbre DX*) This transpired before the reported Indonesian acceptance of East Timorese independence

**TINIAN** The six 500 kW Brown Boveri transmitters at Tinian have an interesting history. They were used at the Radio Free Europe/Radio Liberty relay site at Maxoqueira, Portugal, from 1991 to 1994, perhaps one of most short-lived SW sites ever. In fact, the Maxoqueira transmitters were installed just as VoA was constructing its new site at Briech, Morocco. The new nearby sites were used by VoA and RFE/RL to transmit to the same countries in the same languages at the same times. The end of the Cold War, budget cuts, and the consolidation of VoA and RFE/RL engineering operations resulted in the closing of the Maxoqueira site. Three of the transmitters are now testing at Tinian, and three will come on line at a later this year. (Kim Elliott, *VOA Communications World* via Tom

Sundstrom, via *BC-DX*)

VOA/RFA station is now on regular operation from Jan 15. Tinian is very strong and should be very well received in SE Asia and China, as it is heard at super strength in India and Sri Lanka one more hop away; following according according to detailed monitoring so far:

Tx	UTC	Freq	Service	Language
TIN-01	0800-1000	13650	Net P	(Engl)
	1000-1100	13650	Net R	(Chin)
	1100-1200	13790	Net RFA4	(Lao)
	1200-1300	13790	Net RFA3	(Khme)
	1300-1400	15250	Net R	(Chin)
	1400-1500	15260	Net RFA1	(Cant)
	1500-1600	13735	Net RFA1	(Mand)
	1600-1900	13735	Net RFA1	(Mand)
	1900-2000	11740	Net RFA1	(Mand)
TIN-02	0800-1000	11995	Net P	(Engl)
	1000-1100	11995	Net R	(Chin)
	1100-1200	9860	Net RFA4	(Lao)
	1200-1300	11825	Net R	(Chin)
	1300-1400	11825	Net R	(Chin)
	1400-1500	15470	Net RFA3	(Viet)
	1500-1600	15215	Net RFA2	(Burm)
	1600-1800	11850	Net RFA1	(Mand)
	1800-2000	11790	Net RFA1	(Mand)

It took Vietnam about a week to start jamming 15470 at 1400-1500 with no less than three transmitters. One is a badly humming carrier with a ripple; another open carrier, and a third with Hanoi domestic service (Victor Goonetilleke, Sri Lanka, *DSWCI DX Window*) Reminding us that anti-freedom-of-the-press Communists are still in control (gh)

**USA** WRM1, 9955, relay in Spanish of R. Praga, Czech Republic, at 2230 in clear at first when gave entire Spanish schedule not mentioning WRM1 relay, but at 2250 recheck, Cuban bubble jammers had started up, and still going against R. Vaticano relay at 2315. I thought Fidel was trying to be friendly to the Catholic church? (gh)

WMLK - Their new vertical array antenna, mounted between the two upright red and white masts that support the (sagging) log periodic, was visible from Interstate 78 westbound while passing the transmitter site near Bethel, PA. They also have installed a new sign with call sign and frequency information which can be seen from the road. (Brett Saylor, PA, *Cumbre DX*)

WBCQ - Allan Weiner has asked me to pass along the information that he may no longer be contacted by e-mail. He has decided to give up on e-mail because of the large number of negative and hateful messages received over the past several months. He asks that anyone who needs to contact him phone him at the station in Monticello. (Dan Lewis, [wbcq.net](http://wbcq.net))

During summer DST from April 5, remember that all WBCQ and WWCR programs, including *World of Radio* shift one UT hour earlier, usually on the same frequencies. After WWCR cancelled in Feb our first airing Thu at 2130, we made WBCQ the first airing, by phone-feed minutes after usual production, Wed at 2200 on 7415. However, summer shift to 2100 limits it to daytime absorption. For our latest schedule see: <http://www.angelfire.com/ok/worldofradio>

WGTG - David Franz of WGTG told us by April they were moving to sideband exclusively, except for religious programs on the weekend. This saves so much money in utility bills and transformer tubes, he'll be cutting his hourly rate for commercial customers. Mon and Fri 7:00-7:30 ET he has a program, *Ask WGTG*, in which he answers questions about radio, about the station, about sideband broadcasting, etc., and recommends *Monitoring Times* to new listeners, he says. He says he is considering a program on ham radio including some on-air code practice (Rachel Baughn)

KVOH - On at least two occasions in Jan, High Adventure Ministries was on 5975 kHz in the 0700-0800 period clashing with BBC-Antigua which in winter used that frequency until 0800 (Ivan Grishin, Ont.) Possibly punch-up error for 9975? (gh)

RFPI not only has a *Far Right Radio Review* but a *Far Right Web Review* at: <http://www.clark.net/pub/cwilkins/rfpi/frwr.html> (Chet Copeland, *Review of International Broadcasting*)

[non] *VOA Communications World* tested via Dushanbe, Tajikistan, Sun 0930 on 15605, but there were numerous problems actually getting the program on the air (gh)

**ZIMBABWE** ZBC Radio 4 reactivated 5012 kHz at 0300-0415+, but subsequently kept switching around among 3396 and 4828 (Brian Alexander, PA)

*Until the Next, Best of DX and 73 de Glenn!*



# Broadcast Loggings



Gayle Van Horn

## 0000 UTC on 17820

PHILIPPINES: VOA relay. Special English broadcast noted 0030-0058, fair signal quality and good audio. (Lee Silvi, Mentor, OH) **FEBC Manila** at 1307 at 11995. *Country Crossroads* program of interviews and C&W music. (Mark J. Fine, Remington, VA) **Radio Philippines** on 15330, // 17730, 13770 at 0331 in English/Tagalog. (Walter Salmaniw, Victoria BC, Canada/*Hard Core DX*)

## 0000 UTC on 21740

AUSTRALIA: Radio Australia. World newscast. (Bob Fraser, Cohasset, MA) *At Your Request* music program to ID and 2300 news. (Larry R. Zamora, Garland, TX) Broadcast news at 2200 on 21740. (Dean Burgess, Manchester, MA) Station address: GPO Box 428G, Melbourne VIC 3001, Australia.

## 0005 UTC on 6479.7

PERU: Radio Altura. Spanish huayno music with regional items of fair signal quality. Peru's **Radio Satellite** on 6725.6 at 0025-0045; **Ondas del Rio Mayo** 6797.7 at 2340-0005, "alegria y armonia, canciones por el corazon." (Michael Schnitzer, Hassfurt, Germany/*HCDX*) (Harold Frodge, Midland, MI)

## 0015 UTC on 9485

BULGARIA: Radio Bulgaria. *Events & Developments* feature on reforms in the Bulgarian Army. (Bob Fraser, Cohasset, MA) *Answering Your Letters* on 7375 at 0300. (Jim Boynton, Newton, MA)

## 0024 UTC on 15425

SRI LANKA: SLBC. Signal tone at tune-in to drum signal at 0027. South Asian music to time tips at 0030. Very weak signal, // 9730 stronger, co-channel German speaker's interference. (Salmaniw, CAN) Unknown language to station ID. (Silvi, OH; Frodge, MI)

## 0035 UTC on 6055

SPAIN: Radio Exterior España. Review of a French play based on the life of King Charles I of Spain. (Fraser, MA)

## 0040 UTC on 9685

IRAN: VOIRI. ID to report on religious minorities in Iran. (William McGuire, Cheverly, MD)

## 0150 UTC on 9420

GREECE: Voice of. Greek music to ID. (McGuire, MD) Station on 15485 at 1800 into Spanish service 1815. (Boynton, MA)

## 0200 UTC on 9475

EGYPT: Radio Cairo. Egyptian music into news at 0215. Fair signal quality. (Boynton, MA) *Press Review* on 9990 at 2140. (Howship, UK)

## 0200 UTC on 11705 USB

CUBA: Radio Havana. English broadcast very good signal without interferences, not // on 6000. Parallel frequency carrying Spanish speech. (Silvi, OH) *Mailbag Show* on 13720, 2111-2118+. (Frodge, MI)

## 0315 UTC on 11690

SEYCHELLES: FEBA: Good signal in Farsi over Voz Cristiana (which was stronger on 15375), FEBA heard to abrupt 0330\*. Station on 11885 at 0315 in presumed Swahili to 0345\*. (Paul Ormandy, Oamaru, New Zealand/*HCDX*)

## 0400 UTC on 15325

BRAZIL: Radio Gazeta. Poor to fair Portuguese programming with religious service. (Ormandy, NZ/*HCDX*)

## 0506 UTC on 4960

SAO TOME: VOA relay. African news items to regional music, 0530\*. (Frodge, MI) English news and ID 2050 on 4950. (Willi Passman, Muelheim, Germany)

## 0730 UTC on 17790

ROMANIA: Radio Romania Intl. Feature on holidaying on the Black Sea Coast. (Dave Howship, Birmingham, UK/SWNet) 1730 on 15365. (Boynton, MA; Frank Hillton, Charleston, SC)

## 1140 UTC on 9650

CANADA: Radio Korea Intl. English commentary on the new European currency which may replace the U.S. dollar worldwide and diminish U.S. world influence, fading signal. (Fraser, MA)

## 1202 UTC on 11840

KHAZAKHSTAN: Radio Almaty. Ava Maria vocals to 1208, announcer's program updates. Signal fairly clear but weak and barely audible. (Fine, VA)

## 1235 UTC on 7130

TAIWAN: Radio Taipei. English commentary on Taiwan calling it "an armed island" into pop bumper music to station ID and Chinese music. (Fraser, MA) Taiwan's **Voice of Asia** on 9985, 2157-2200\* in German and English. (McGuire, MD)

## 1249 UTC on 21510

UKRAINE: Radio Ukraine Int'l. English music program to frequency quote, good signal. (Fine, VA; Howship, UK; Salmaniw, CAN) Station address: Kreshchatik str, 26, 25001 Kiev, Ukraine.

## 1506 UTC on 17535

ISRAEL: Kol Israel. Foreign Minister visits Moscow on Middle East peace progress, // 15650. Stock market reports to business updates and weather to 1530\*. (Zamora, TX; Howship, UK)

## 1700 UTC on 11690

JORDAN: Radio Jordan. Station interval signal to ID and regional news. National weather forecast, U.S. political news headlines. (McGuire, MD) Station address: P.O. Box 1041, Amman, Jordan) (Howship, UK)

## 1745 UTC on 7515

TAJIKISTAN: Tajik Radio. Lengthy talks in Tajik by man about Sudan // 5800 at 1750. Strong interference from 7525 via **Croatian Radio**. Muffled modulation and microphone noise. (Zacharias Liangas, Thessoloniki, Greece/*HCDX*)

## 1749 UTC on 4790

PAKISTAN: Radio Pakistan. Music to Holy Koran recitations, 1759 open carrier. (Liangas, GRC/*HCDX*)

## 1802 UTC on 4828

ZIMBABWE: ZBC. Poor signal of station, possibly relaying BBC newscast. Strong interference from Voice of Mojahed at 1803 and at 1805 by a jammer. (Liangas, GRC/*HCDX*)

## 1941 UTC on 3235

PAPUA NEW GUINEA: Radio West New Britain. Native drums to regional choir music and brief station information. Continued choir vocals to 2000 **NBC** network news into regional Pidgin, // 4890 **NBC-Port Moresby**. (Karl Van Rooy, Netherlands/*HCDX*)

## 1950 UTC on 11900

KUWAIT: Radio Kuwait. English rock and rap music to "this is Kuwait" ID at 2000. Interference from UK's Merlin Network One on 11900 at 2000. (Frodge, MI; Howship, UK; Hillton, SC)

## 2044 UTC on 5050

TANZANIA: USB to avoid Togo on 5047. Afro music to 2050, recitations, commentary to mentions of "Zanzibar" in local language. Anthem to 2100\*. (Frodge, MI; Hillton, SC)

## 2100 UTC on 11954.75

ANGOLA: Radio Nacional. Heard for several hours with enjoyable local Portuguese programming, time pips just before 2100, short fanfare, no obvious ID until 2103 with time check and two "Radio Nacional Angola" IDs. Very good signal! (Salmaniw, CAN/*HCDX*) Address: Caixa Postal 1329, Luanda, Angola.

## 2115 UTC on 11620

INDIA: All India Radio. English vocal music program to 2119, // 7410. (Frodge, MI; Salmaniw, CAN; Boynton, MA) **AIR-Port Blair** 4760, 2325-23335 in Hindu to national anthem, local ID and newscast. (Schnitzer, Germany/*HCDX*; Liangas, GRC/*HCDX*)

## 2113 UTC on 15500

MALI: China Radio Intl. China News featuring a story on the oldest bamboo book discovered, // 11975, good signal but fights with equal power **Voice of America**. (Fraser, MA; Hillton, SC)

## 2250 UTC on 4965

BOLIVIA: Radio Juan XXIII. Spanish. Pop music segments to regional headlines. Bolivians audible; **Radio Eco** 4702.2 at 2305-2315 with news headlines; **Radio Perla del Acre** 4600 at 2315-2325. (Schnitzer, Germany; Hassfurt, Germany)

Thanks to our contributors — Have you sent in YOUR logs?  
Send to **Gayle Van Horn**, c/o *Monitoring Times* (or e-mail [gayle@grove.net](mailto:gayle@grove.net))  
English broadcast unless otherwise noted.

## Sign of the Times ... Part Deux ?

Thanks for all the letters in response to last month's opener, "Sign of the Times?" With an overwhelming response, DXers agree our radio hobby is in the midst of major changes, with predictions of more to occur, not to mention the constant changes in QSL policies among stations. (Aren't you glad you read *MT*?)

Our Atlanta, Georgia, contributor, Bill Holscher, reminded me that England's Merlin Network One has ceased sending QSL cards until October 1999, this according to MNO's Eric Wiltsher. Perhaps some friendly persuasion via email might assist your reply rate at [eric@mno.net](mailto:eric@mno.net) or [mno@cix.co.uk](mailto:mno@cix.co.uk). The station's website is at <http://www.mno.co.uk/>

Lee Silvi of Mentor, Ohio, sent word of changes in Voice of Russia's QSL policy that states, "we apologize for the delay in posting our correspondence, which is caused by our station's budgetary constraints. At the present time we reply to listener's letters by email only." Reports may be sent via cyberspace to [letters@vor.ru](mailto:letters@vor.ru); VOR's website is <http://www.vor.ru>

Tom Banks of Dallas, Texas, also reminded me recently of



Radio China International's English website at <http://english.cri.com.cn> with an email link for reports to [crieng@mail.cri.com.cn](mailto:crieng@mail.cri.com.cn). Thanks, Tom.

*MT*'s Glenn Hauser passed some QSL news from Radio Korea International. This being the *Year of Architecture*, RKI has initiated that theme for both shortwave and Internet reception reports. Several designs will be issued throughout the year. Program details may be addressed to: Overseas Service, Korean Broadcasting System, 18 Yoido-dong, Youngdungpo-gu, Seoul, Republic of Korea 150-790. KBS website: <http://www.kbs.co.kr>. Click on the Radio Korea International link <http://rki.kbs.co.kr/rki/index.htm> - Email [rki@kbsnt.kbs.co.kr](mailto:rki@kbsnt.kbs.co.kr).

Just received word of new QSL changes? Or maybe you have a question or column idea. Your cards and letters are always welcome. Send your mail to QSL Report, c/o Monitoring Times, P.O. Box 98, Brasstown, N.C. 28902. If you'd like a personal reply please enclose a SASE. If the Internet has become your forté, send me your email at: [gayle@grove.net](mailto:gayle@grove.net). Please keep us informed of these changing times in radio!

### CHILE

Radio Voz Cristiana, 11690 kHz. Full data logo postcard unsigned. Received in two weeks for an English report and one mint stamp. Station address: P.O. Box 2889, Miami, FL 33144. (Randy Stewart, Springfield, MO)

### COSTA RICA

AWR, 6975 kHz. Full data transmitter site card initialed by A.P. Verification for special broadcast of *Wavescan* on World of Radio via RFPI. QSL stamps, stickers, postcards, newsletter and reception report cards enclosed. Received in 25 days for an English report and two mint stamps. Station address: c/o AWR Wavescan, Box 29235, Indianapolis, IN 46229. (Bill Wilkins, Springfield, MO)

### FM

CBHN-89.5 MHz. Full data prepared card verified by Greg Miller. Two different metal lapel pins for CBC Radio 60 & CBC Radio One. Received in three weeks for an FM report and mint stamps (returned with reply). Station address: CBC, Box 3000, Halifax NS Canada B3J 3E9. (Robert Ross, London, Ontario, Canada)

### MEDIUM WAVE

CKBL, 1150 kHz AM. Verification letter signed by Jason Mawr-Program Director. Received in 10 days for a taped report. Station address: Okanagan Radio Unlimited, 300-435 Bernard Ave., Kelowna BC Canada V1Y 6N6. (Patrick Martin, Seaside, OR)

KCCF, 1550 kHz AM. Verification letter signed by Chuck Lee-Program Director. Received in 53 days for an AM report. Station address: P.O. Box 847, Ferndale, WI 98248. (Martin, OR)

KDIA, 1640 kHz AM, Vallejo, California. Received second verification letter in one month, (several follow ups had been sent) signed again by Clifford Brown III-Program Assistant. Received for an AM report. Station address: 7677 Oakport St., # 105, Oakland, CA 94621. (Martin, OR)

KIQN, 1010 kHz AM. Partial data letter signed by Christopher Wilde-Program Director, plus coverage map. Received in 23 days for a taped report. Station heard with night power of 13 watts. Station address: Eagle Gate Plaza, 60 East Temple # 120, Salt Lake City, UT 84111. (Martin, OR)

KWLW, 700 kHz AM. Verification letter signed by Dickie Shannon-Program Director. Received in 11 days for a taped report. Station address: 312 East South Temple, Salt Lake City, UT 84111. (Martin, OR)

### NICARAGUA

Radio Miskut, 5770 kHz. Full data personal letter from Evaristo Mercado Perez-Director. Received in 10 1/2 months for a Spanish report, tape and one US dollar. Station address: RAAN(Region Autonoma del Atlantico Norte) Nicaragua. (Stewart, MO)

### NORWAY

Radio Norway International, 9945 kHz. Full data Trolls card signed with illegible signature. Received in 70 days for an English report of last English broadcast. Station address: 0340 Oslo, Norway. (Brian Bagwell, St Louis, MO)

### PIRATE

Betty Boop Radio, 6955 kHz USB. Full data *Betty Boop* cartoon sheet signed by Rollo Verndigh/Keelo Verndigh. QSL received for *Free Radio Weekly* pirate logs of July 23 and October 31, broadcast via Radio Eclipse. QSL maildrop: P.O. Box 28413, Providence, RI 02908. (Harold Frodge, Midland, MI)

He Man Radio, 6955 kHz USB. Full data *Green Talea Jurrens* sheet unsigned. Received in 56 days for a pirate report and three mint stamps. QSL maildrop: P.O. Box 109, Blue Ridge Summit, PA 17214. (Frodge, MI)

Jerry Rigged Radio, 6955 kHz USB. Full data *21<sup>st</sup> Century Pirate Hunter* sheet unsigned. Received in five weeks for a pirate report and three mint stamps. QSL maildrop: Providence, R.I. (Wilkins, MO)

Radio Garbanzo, 6955 kHz. Full data *Farewell to P.J.* sheet signed by F.F. (Fearless Fred). Received in 148 days for a pirate report and three mint stamps. QSL maildrop: P.O. Box 1, Belfast, NY 14711. (Frodge, MI)

### RUSSIA

Voice of Russia, 11675 kHz. Full data QSL card noted as transmitter via Krasnodar, unsigned plus a typewritten note stating new QSL policy. Station address: ul. Pyatnitskaya 25, Moscow 113326, Russia. (Lee Silvi, Mentor, OH)

### USA

American Forces Radio and TV Service, 12689.5 kHz via Naval Computer and Telecommunications Area Master Station, Key West, Florida. Partial data email form letter from Wayne E. Eternicka-Broadcast Operations Specialist. Received in five days for a snailmail report. Mr. Eternicka's email address: [eternicka@mediacen.navy.mil](mailto:eternicka@mediacen.navy.mil). Postal address: Naval Media Center, Navsta Anacostia Bldg 168, 2701 S. Capitol St. NW, Washington, DC 20373-5819. (Stewart, MO)



# ...SURVIVABLE COMMUNICATIONS!

## When conventional power systems go down, you're ready!



**Emergency Power** Lightweight and compact, the PWR-1 has a 7 ampere-hour rechargeable gel-cell to guarantee instant access to 12, 9, 6, or 3 Volts DC, available from three simultaneous outputs, and two simultaneous voltages! A built-in voltmeter instantly alerts you to charge conditions. Cables and universal connectors are included.

Two cigarette lighter sockets allow recharging the portable power station, or powering your accessories. Use the included AC module for overnight recharging, or fully charge on the fly in just 3 hours from your car! You will be alerted by the blinking charge light when your unit's ready for action; an automatic shutoff prevents overcharging.

**ORDER PWR 1 Only \$59<sup>95</sup>** plus \$5.95 US Priority Mail or UPS shipping

**Emergency Radio** The sensational FreePlay FPR2S AM/FM radio is now available from Grove! Simply turn the generator crank for 30 seconds and enjoy up to an hour of reception! And during daylight, solar power operates the radio non-stop!

**ORDER RCV 30 Only \$79<sup>95</sup>** plus \$5.95 US Priority Mail or UPS shipping

The world-acclaimed FPR1 also provides shortwave reception in addition to AM/FM (but no solar power); model A receives 3.3-12 MHz, and model B receives 5.8-18 MHz. A 30 second winding provides 30 minutes of reception.

**ORDER RCV 29 Only \$99<sup>95</sup>** plus \$5.95 US Priority Mail or UPS shipping



**Emergency Lighting** Imagine never having to buy flashlight batteries again--or even recharging! Yet you can store this flashlight indefinitely and count on instant light! The FreePlay self-powered lantern utilizes a high-efficiency, hand-operated generator to provide its reassuring beacon. Even better, its generator can also be used to power small accessories, such as dual-AA-battery-operated radios, recorders, and other electronic instruments, or even to recharge their batteries.

**ORDER LIT 1 Only \$69<sup>95</sup>** plus \$5.95 US Priority Mail or UPS shipping

# GROVE

Grove Enterprises, Inc.  
1-800-438-8155 (US & Canada)

828-837-9200

FAX 828-837-2216

7540 Highway 64 West  
Brasstown, NC 28902-0098

web: [www.grove-ent.com](http://www.grove-ent.com)

e-mail: [order@grove-ent.com](mailto:order@grove-ent.com)

## HOW TO USE THE SHORTWAVE GUIDE . . . . .

### 1: Convert your time to UTC.

Eastern and Pacific Times are already converted to Coordinated Universal Time (UTC) at the top of each page. The rule is: convert your local time to 24-hour format; add (during Daylight Savings Time) 4,5,6, or 7 hours for Eastern, Central, Mountain or Pacific Times, respectively.

Note that all dates, as well as times, are in UTC; for example, a show which might air at 0030 UTC Sunday will be heard on Saturday evening in America (8:30 pm Eastern, 5:30 pm Pacific).

### 2: Choose a program or station you want to hear.

Some selected programs appear on the lower half of the page for prime listening hours—space does not permit 24-hour listings.

Occasionally program listings will be followed by "See X 0000." This information indicates that the program is a rerun, and refers to a previous summary of the program's content. The letter stands for a day of the week, as indicated below, and the four digits represent a time in UTC.

S: Sunday T: Tuesday H: Thursday A: Saturday  
M: Monday W: Wednesday F: Friday

### 3: Find the frequencies for the program or station you want to hear.

Look at the page which corresponds to the time you will be listening. Comprehensive frequency information for English broadcasts can be found at the top half of the page. All frequencies are in kHz.

The frequency listing uses the same day codes as the program listings; if a broadcast is not daily, those day codes will appear before the

station name. Irregular broadcasts are indicated "tent" and programming which includes languages besides English are coded "v" (various languages).

### 4: Choose the most promising frequencies for the time, location and conditions.

Not all stations can be heard and none all the time on all frequencies. To help you find the most promising frequency, we've included information on the target area of each broadcast. Frequencies beamed toward your area will generally be easier to hear than those beamed elsewhere, even though the latter will often still be audible. Every frequency is followed by one of these target codes:

am: The Americas	as: Asia
na: North America	au: Australia
ca: Central America	pa: Pacific
sa: South America	va: various
eu: Europe	do: domestic broadcast
af: Africa	om: omnidirectional
me: Middle East	

Consult the propagation charts. To further help you find the right frequency, we've included charts at the back of this section which take into account conditions affecting the audibility of shortwave broadcasts. Simply pick out the region in which you live and find the chart for the region in which the station you want to hear is located. The chart indicates the optimum frequencies for a given time in UTC.

## HOT NEWS . . . . .

COMPILED BY JIM FRIMMEL

• **BBC SINGAPORE.** The Radio Corporation of Singapore announced the start of its introductory DAB Digital Radio Service for this island country of three million people. BBC World Service is available on FM 93.8 24 hours daily.

• **DAB PORTABLE RECEIVER.** Roberts Radio, Roke Manor Research, Loughborough University and World Radio Network are jointly developing a new portable DAB receiver to be built in Great Britain. Prototypes will be tested by the end of 1999 and the units will be in the hands of retailers by the year 2000.

• **ODXA MILESTONE.** The Ontario DX Association is celebrating its 25th anniversary and has been issued the callsign XL3D in place of VE3ODX for the period 25 March thru 25 April 1999. Visit <<http://www.durhamradio.com/odxa/index.html>> for membership information and sample columns and publications.

• **ELECTRONIC DX PRESS.** Australia's Bob Padula, the driving force behind the *EDXP Newsletter* and publisher of Padula Books, has restructured his electronic newsletter for shortwave broadcast DXers. Individual recipients are now asked to contribute a small \$5 fee semiannually to offset the costs involved in the production of an outstanding electronic periodical that brings the latest shortwave broadcast news directly to your desktop. The EDXP website at <<http://members.tripod.com/~bpadula/edxp.html>> provides all the details and gives you an opportunity to request a sample copy.

• **HARD-CORE-DX.** Risto Kotalampi of Finland provides a free mailing list service for DXers <<http://www.best.com/~rko/hard-core-dx/>>. Categories of E-mail reports are limited to rare and difficult to hear shortwave and medium wave stations. Wonderful exchanges of topical informa-

tion occasionally arise like the recent interchange of messages on the design and use of beverage antennas. Check the web site for the procedure to subscribe to the HCDX mailing list.

• **SHORTWAVE.** The increase in the number of recent requests for DX Computing's demo diskette of Macintosh software and utilities for DXers (see the ad in this current issue) seems to reflect a rise in the number of new Macintosh users who are in the radio hobby. The popularity of the new Mac computer (tops overall in computer sales during the Christmas holidays) may have had a positive effect on radio hobbyists who are first-time buyers of computer equipment, since it is unlikely that very many PC/Windows users would be willing to sacrifice their monetary investment in software and accessory equipment. This may be a sign that these computer buyers are also new to radio; a very good

indicator that our hobby is doing well.

• **SPRING FORWARD.** The seven days between Palm Sunday and Easter Sunday is this year's week of limbo, a time when most of the world has already switched over to Daylight Savings Time (DST) on March 28th, but North America is still on Standard Time until April 4th. Why can't we all get together?



• **WORLD RADIO NETWORK.** You'll find in this month's Selected Programming a lot of entries for WRN. You won't find this international programming on HF frequencies; you'll find it on your satellite dish. See page 62 for how to tune in WRN1 and 2. Check WRN's website at [www.wrn.org](http://www.wrn.org) for the latest summer schedule changes, not yet available at presstime.



## FREQUENCIES

0000-0100	Anguilla, Caribbean Beacon	6090am				0000-0100	UK, BBC World Service	3915as	5965as	5970sa	5975am
0000-0100 vl	Australia, ABC/Kathenne	5025do						6175na	6195as	7110as	9410as
0000-0100 vl	Australia, ABC/Tent Creek	4910do						9590am	9915sa	11945as	11955as
0000-0100	Australia, Radio	9660pa	12080as	15240pa	17715pa			12095sa	15280as	15310as	15360as
		17795pa	21740pa					17790as			
0000-0015	Cambodia, Nat'l Radio Of	11940as				0000-0100	UK, Merlin Network One	3985eu	9560na		
0000-0100	Canada, CBC N Quebec Svc	9625do				0000-0100	Ukraine, R Ukraine Intl	5905eu	6020eu	6030na	7150as
0000-0100	Canada, CFRX Toronto	6070do						7205eu	9560eu		
0000-0100	Canada, CFVP Calgary	6030do				0000-0100	USA, KAIJ Dallas TX	5810na			
0000-0100	Canada, CHNX Halifax	6130do				0000-0100	USA, KTBN Salt Lk City UT	7510am			
0000-0100	Canada, CKZN St John's	6160do				0000-0100	USA, KWHR Naalehu HI	17510as			
0000-0100	Canada, CKZU Vancouver	6160do				0000-0100	USA, Voice of America	7215as	9890as	11760as	15185as
0000-0029 twfha	Canada, R Canada Intl	6040am	9535am	11865am				15290as	17735pa	17820as	
0000-0059	Canada, R Canada Intl	5960am	9755am			0000-0100 twfha	USA, Voice of America	5995ca	6130ca	7405sa	9455ca
0000-0100	Costa Rica, RF Peace Intl	6975am	15050am	21460am				9775sa	11695ca	13740sa	
0000-0027	Czech Rep, R Prague Intl	7345na	9465na			0000-0030	USA, Voice of America	5995ca	6130ca	7405sa	9455ca
0000-0100	Ecuador, HCJB	9745na	12015na	21455va				9775sa	11695ca	13740sa	
0000-0030	Egypt, Radio Cairo	9900am				0000-0100	USA, WBCQ Monticello ME	7415na			
0000-0100 vl	Guatemala, Radio Cultural	3300do				0000-0100	USA, WEWN Birmingham AL	5825na	9385eu		
0000-0100	Guyana, GBC/Voice of	3290do	5950do			0000-0100	USA, WGTG McCaysville GA	5085am	6890na		
0000-0045	India, All India Radio	5010do	7410as	9705as	9950as	0000-0100	USA, WHRA Greenbush VE	7395af			
		11620as	13625as			0000-0100	USA, WHRI Noblesville IN	7315am			
0000-0015	Japan, Radio/NHK	6155eu	6180eu	9665af	11705na	0000-0100 twfha	USA, WHRI Noblesville IN	5745am			
		11815as	13650as			0000-0100 sm	USA, WHRI Noblesville IN	5755am			
0000-0100	Liberia, LCN/R Liberia Int	5100do				0000-0100	USA, WINB Red Lion PA	11950ca			
0000-0100	Malaysia, Radio	7295do				0000-0100	USA, WJCR Upton KY	7490na	13595as		
0000-0100	Malaysia, RTM Sarawak	7160do				0000-0100	USA, WRMI/R Miami Intl	9955sa			
0000-0100 vl	Malaysia, RTM Kota Kinabalu	5980do				0000-0100	USA, WRNO New Orleans LA	7355am			
0000-0100 vl	Namibia, NBC	3270af	3289af			0000-0100 vl	USA, WSHB Cypress Crk SC	7535am	9430am		
0000-0100	Netherlands, Radio	6165na	9845na			0000-0100 as	USA, WWBS Macon GA	11900na			
0000-0100	New Zealand, R NZ Intl	17675pa				0000-0100	USA, WWCR Nashville TN	3215na	5070na	5935na	7435na
0000-0100	North Korea, R Pyongyang	11845am	13650am	15230am		0000-0100	USA, WYFR Okeechobee FL	6085na	9505na		
0000-0100 vl	Papua New Guinea, NBC	9675do				0000-0030 vl	Vanuatu, Radio	4960do			
0000-0100	Philippines, FEBC/R Intl	15450as				0015-0100	Japan, Radio/NHK	6155eu	6180eu	9665af	11705na
0000-0030 mtwfa	Serbia, Radio Yugoslavia	7115na				0030-0100	Austria, R Austria Intl	7325na			
0000-0100	Singapore, R Corp Singapore	6150do				0030-0100	Iran, VOIRI	6060na	9022eu	9685am	
0000-0100	Spain, R Exterior Espana	6055am				0030-0100 vl	Solomon Islands, SIBC	5020do			
0000-0100	Sri Lanka, IBC Tamil	7460as				0030-0100	Sri Lanka, Sri Lanka BC	6005as	9730as	15425as	
0000-0030	Thailand, Radio	9655af	9680af	11905af		0030-0100	Thailand, Radio	9655as	11905as	13695am	
						0050-0100	Italy, RAI Intl	6010na	9675na	11800na	

## SELECTED PROGRAMS

### Sundays

- 0000 Australia, Radio: RA News. Five or ten minutes of world, Australian, and regional news.
- 0000 Swiss Radio Intl via WRN1 (NAM): World Radio Switzerland.
- 0000 UK, BBC London (as): The World Today (EAs/SAs). The World Service breakfast program.
- 0000 UK, BBC London (as): World News. Broadcast on the hour of 5, 10, or 15 minutes in length.
- 0005 Australia, Radio: Money, Markets, and the Economy. Making sense of our economic world - a project presented by Monash University, Radio Australia, Radio National and ABC Online.
- 0035 UK, BBC London (as): From Our Own Correspondent. BBC correspondents comment on the background to the news.
- 0030 Australia, Radio: Correspondents' Report. The ABC's foreign correspondents report home with Hamish Robertson.
- 0030 UK, BBC London (as): Agenda. This series examines the latest ideas and trends.

### Mondays

- 0000 Australia, Radio: RA News. See S 0000.
- 0000 Swiss Radio Intl via WRN1 (NAM): World Radio Switzerland.
- 0000 UK, BBC London (as): The World Today (EAs/SAs). See S 0000.
- 0000 UK, BBC London (as): World News. See S 0000.
- 0005 UK, BBC London (as): Health Matters. Keeps track of new developments in the world of medical science, as well as ways of keeping fit.
- 0010 Australia, Radio: Correspondents' Report. See S 0030.
- 0012 Swiss Radio Intl via WRN1 (NAM): Swiss Scene.
- 0030 Australia, Radio: The Health Report. A program that examines health issues and makes complex scientific data understandable.
- 0030 UK, BBC London (as): Omnibus. Each week a half-hour programme on practically any topic under the sun.

### Tuesdays

- 0000 Australia, Radio: RA News. See S 0000.
- 0000 Swiss Radio Intl via WRN1 (NAM): World Radio Switzerland.
- 0000 UK, BBC London (as): The World Today (EAs/SAs). See S 0000.
- 0000 UK, BBC London (as): World News. See S 0000.
- 0005 UK, BBC London (as): Discovery. In-depth look at scientific research.

- 0010 Australia, Radio: Asia Pacific. See M 1110.
- 0010 Radio Australia via WRN1 (NAM): Asia Pacific.
- 0030 Australia, Radio: The Law Report. Susanna Lobez brings an insider's perspective to the complexities of the law.
- 0030 Swiss Radio Intl via WRN1 (NAM): Rendez-vous with Switzerland.
- 0030 UK, BBC London (as): Variable Feature. See S 1530.

### Wednesdays

- 0000 Australia, Radio: RA News. See S 0000.
- 0000 Swiss Radio Intl via WRN1 (NAM): World Radio Switzerland.
- 0000 UK, BBC London (as): The World Today (EAs/SAs). See S 0000.
- 0000 UK, BBC London (as): World News. See S 0000.
- 0005 UK, BBC London (as): One Planet. Charles Haviland and Richard Black host this new program about development and the environment.
- 0010 Australia, Radio: Asia Pacific. See M 1110.
- 0010 Radio Australia via WRN1 (NAM): Asia Pacific.
- 0030 Australia, Radio: The Religion Report. Hosted by John Cleary.
- 0030 UK, BBC London (as): Sports International. Live commentaries and interviews, features and discussions.

### Thursdays

- 0000 Australia, Radio: RA News. See S 0000.
- 0000 Swiss Radio Intl via WRN1 (NAM): World Radio Switzerland.
- 0000 UK, BBC London (as): The World Today (EAs/SAs). See S 0000.
- 0000 UK, BBC London (as): World News. See S 0000.
- 0005 UK, BBC London (as): The Works. Alun Lewis looks at the impact of tomorrow's technology.
- 0010 Australia, Radio: Asia Pacific. See M 1110.
- 0010 Radio Australia via WRN1 (NAM): Asia Pacific.
- 0030 Australia, Radio: Media Report. Agnes Warren presents the inside story on how the communications industry operates and puts the spotlight on media people and their activities.
- 0030 UK, BBC London (as): Assignment. A weekly examination of a topical issue.

### Fridays

- 0000 Australia, Radio: RA News. See S 0000.
- 0000 Swiss Radio Intl via WRN1 (NAM): World Radio Switzerland.
- 0000 UK, BBC London (as): The World Today (EAs/SAs). See S 0000.
- 0000 UK, BBC London (as): World News. See S 0000.
- 0005 UK, BBC London (as): Science in Action. The latest in science and

- technology.
- 0000 Australia, Radio: Asia Pacific. See M 1110.
- 0010 Radio Australia via WRN1 (NAM): Asia Pacific.
- 0030 Australia, Radio: The Sports Factor. Amanda Smith hosts the program that debates Australia's sporting culture.
- 0030 Swiss Radio Intl via WRN1 (NAM): Rendez-vous with Switzerland.
- 0030 UK, BBC London (as): Focus on Faith. Alison Hilliard talks to church leaders about their hopes for the future.

### Saturdays

- 0000 Australia, Radio: RA News. See S 0000.
- 0030 Swiss Radio Intl via WRN1 (NAM): World Radio Switzerland.
- 0030 UK, BBC London (as): The World Today. See S 0000.
- 0035 Australia, Radio: Feedback. See S 0305.
- 0010 Radio Australia via WRN1 (NAM): Asia Pacific
- 0010 UK, BBC London (as): Waveguide (4). See S 1230
- 0010 UK, BBC London (as): Write On. See S 1230.
- 0025 UK, BBC London (as): Science View. See T 0605.
- 0030 Australia, Radio: Asia Pacific. See M 1110
- 0030 Swiss Radio Intl via WRN1 (NAM): Rendez-vous with Switzerland.
- 0030 UK, BBC London (as): People and Politics. Background to the British political scene.

Macintosh Software

---

SHORTWAVE NAVIGATOR  
FREQUENCY VALET • UTCLOCK

---

FREQUENCIES/PROGRAMS/COMPUTER CONTROL  
(DRAKE • KENWOOD • JRC)

---

SEND \$2 FOR DEMO DISK TO:  
**DX COMPUTING • 232 SQUAW CREEK RD.  
WILLOW PARK, TX 76087**

FREQUENCIES

0100-0200	Anguilla, Caribbean Beacon	6090am				0100-0130	Slovakia, R Slovakia Intl	5930na	7300ca	9440sa
0100-0200 vl	Australia, ABC/Kathenne	5025do				0100-0200 vl	Solomon Islands, SIBC	5020do		
0100-0200 vl	Australia, ABC/Tent Creek	4910do				0100-0200	Spain, R Exterior Espana	6055am		
0100-0200	Australia, Radio	9660pa	12080as	15240pa	15415as	0100-0200	Sri Lanka, Sri Lanka BC	6005as	9730as	15425as
		17715pa	17750as	17795pa	21740pa	0100-0130	Switzerland, Swiss R Intl	9885na	9905na	
0100-0200	Canada, CBC N Quebec Svc	9625do				0100-0200	UK, BBC World Service	5965as	5970sa	5975am 6175na
0100-0200	Canada, CFRX Toronto	6070do						6195as	9410as	9590am 9915sa
0100-0200	Canada, CFPV Calgary	6030do						11955as	12095sa	15280as 15310as
0100-0200	Canada, CHNX Halifax	6130do						3985e	9560na	
0100-0200	Canada, CKZN St John's	6160do				0100-0200	UK, Merlin Network One	5810u		
0100-0200	Canada, CKZU Vancouver	6160do				0100-0200	USA, KALJ Dallas TX	7510am		
0100-0200	Costa Rica, RF Peace Intl	6975am	15050am	21460am		0100-0200	USA, KFTN Salt Lk City UT	7510am		
0100-0200	Cuba, Radio Havana	6000na	9820na	11705na	13605na	0100-0200	USA, KWHR Naalehu HI	117510as		
0100-0127	Czech Rep., R Prague Intl	6200na	7345na			0100-0200	USA, Voice of America	7115as	7200as	9740as 9850as
0100-0200	Ecuador, HCJB	9745na	12015na	21455va				11705as	15250as	15300as 17740as
0100-0150	Germany, Deutsche Welle	5960am	6040na	6145am	9640am			17820as		
		9700na				0100-0200 twtfa	USA, Voice of America	5995ca	6130ca	7405sa 9455ca
		6155na						9775sa	13740sa	
0100-0130 m	Germany, V O Deliverance	6155na				0100-0200	USA, WBCC Monticello ME	7415na		
0100-0200 s	Germany, Good News World R	6155eu				0100-0200	USA, WEWN Birmingham AL	5825na	9385u	
0100-0200 vl	Guatemala, Radio Cultural	3300do				0100-0200	USA, WGTG McCaysville GA	5085am	6890na	
0100-0200	Guyana, GBC/Voice of	3290do	5950do			0100-0200	USA, WHRA Greenbush ME	7395af		
0100-0130	Hungary, Radio Budapest	6135na	9835na			0100-0200	USA, WHRI Noblesville IN	7315am		
0100-0200	Indonesia, Voice of	9525as	11765as	15510as		0100-0200 twtfa	USA, WHRI Noblesville IN	5745am		
0100-0130	Iran, VO/RI	6060na	9022eu	9685am		0100-0200 sm	USA, WHRI Noblesville IN	5755am		
0100-0110	Italy, RAI Intl	6010na	9675na	11800na		0100-0200	USA, WINB Red Lion PA	11950ca		
0100-0200	Japan, Radio/NHK	6150af	11860as	11890af	15325as	0100-0200	USA, WJCR Upton KY	7490na	13595as	
		15570as	15590as	17685pa	17810as	0100-0200	USA, WRMI/R Miami Intl	9955sa		
		17835sa	21670pa			0100-0200	USA, WRNO New Orleans LA	7355am		
0100-0200	Kenya, Kenya BC Corp	4885do				0100-0200 vl	USA, WSHB Cypress Crk SC	7535am	9430am	
0100-0200	Liberia, LCN/R Liberia Int	5100do				0100-0200	USA, WVCR Nashville TN	3215na	5070na	5935na 7435na
0100-0200	Malaysia, Radio	7295do				0100-0200	USA, WYFR Okeechobee FL	6065na	9505na	15165as
0100-0200 vl	Malaysia, RTM Kota Kinabalu	5980do				0100-0130	Uzbekistan, R Tashkent	5955as	5975as	7105as 7285as
0100-0200 vl	Namibia, NBC	3270af	3289af			0100-0127	Vietnam, Voice of	5940na		
0100-0125	Netherlands, Radio	6165na	9845na			0115-0145 vl	Libya, Voice of Africa	15235va	15415va	15435va
0100-0200	New Zealand, R NZ Intl	17675pa				0130-0200	Austria, R Austria Intl	7325na	9495sa	9870sa
0100-0200 vl	Papua New Guinea, NBC	9675do				0130-0200	Sweden, Radio	7265au	9435as	11985as
0100-0200	Philippines, FEBC/R Intl	15450as				0140-0150	Greece, Voice of	7450na	7475na	9375na 9420na
0100-0200	Russia, Voice of Russia WS	7180na	9875na	12020na	15595na	0140-0200	Vatican State, Vatican R	7335au	9650au	
0100-0130	Serbia, Radio Yugoslavia	7130na								
0100-0200	Singapore, R Corp Singapore	6150do								

SELECTED PROGRAMS

Sundays

- 0100 Australia, Radio: RA News. See S 0000.
- 0100 Radio Australia via WRN1 (NAAm): RA News.
- 0100 UK, BBC London (as): The World Today. See S 0000.
- 0105 Australia, Radio: The Europeans. Maria Zijlstra presents reports and features on aspects of European politics, culture and society.
- 0105 Radio Australia via WRN1 (NAAm): Book Reading.
- 0115 Radio Australia via WRN1 (NAAm): Lingua Franca.
- 0130 Channel Africa via WRN1 (NAAm): News.
- 0130 UK, BBC London (as): Global Business. Roger White presents this weekly series of interviews, features and discussions with the movers and shakers of the international business community.

Mondays

- 0100 Australia, Radio: RA News. See S 0000.
- 0100 Radio Australia via WRN1 (NAAm): RA News.
- 0100 UK, BBC London (as): World News. See S 0000.
- 0105 UK, BBC London (as): The Farming World. Reports on new developments from around the world.
- 0110 Australia, Radio: Awaye. Lorena Allam hosts a program of indigenous arts and issues.
- 0110 Radio Australia via WRN1 (NAAm): Correspondents' Report.
- 0120 UK, BBC London (as): Health Matters. See M 0005.
- 0145 UK, BBC London (as): Off the Shelf. Daily readings from the best of world literature.

Tuesdays

- 0100 Australia, Radio: RA News. See S 0000.
- 0100 Radio Australia via WRN1 (NAAm): RA News.
- 0100 UK, BBC London (as): World News. See S 0000.
- 0105 UK, BBC London (as): Insight. An examination of a topical aspect of the international scene.
- 0110 Australia, Radio: Science Show. Robyn Williams presents the world of science, both at home and abroad.
- 0120 UK, BBC London (as): Discovery. See T 0005.
- 0130 R Slovakia Intl via WRN1 (NAAm): Slovakia Today.
- 0133 R Slovakia Intl via WRN1 (NAAm): News.
- 0138 R Slovakia Intl via WRN1 (NAAm): Topical Issues.
- 0141 R Slovakia Intl via WRN1 (NAAm): Slovak Weather News.
- 0143 R Slovakia Intl via WRN1 (NAAm): Tourism in the Slovak Republic.
- 0145 UK, BBC London (as): Off the Shelf. See M 0145.

Wednesdays

- 0100 Australia, Radio: RA News. See S 0000.
- 0100 Radio Australia via WRN1 (NAAm): RA News.
- 0100 UK, BBC London (as): World News. See S 0000.
- 0105 UK, BBC London (as): Insight. See T 0105.
- 0110 Australia, Radio: The National Interest. See S 1605.
- 0120 UK, BBC London (as): One Planet. See W 0005.
- 0130 R Slovakia Intl via WRN1 (NAAm): Slovakia Today.
- 0133 R Slovakia Intl via WRN1 (NAAm): News.
- 0138 R Slovakia Intl via WRN1 (NAAm): Topical Issues.
- 0145 UK, BBC London (as): Off the Shelf. See M 0145.

Thursdays

- 0100 Australia, Radio: RA News. See S 0000.
- 0100 Radio Australia via WRN1 (NAAm): RA News.
- 0100 UK, BBC London (as): World News. See S 0000.
- 0105 UK, BBC London (as): Insight. See T 0105.
- 0110 Australia, Radio: Background Briefing. Australia's top award-winning current affairs program.
- 0120 UK, BBC London (as): The Works. See H 0005.
- 0145 UK, BBC London (as): Off the Shelf. See M 0145.
- 0153 R Slovakia Intl via WRN1 (NAAm): Business News.

Fridays

- 0100 Australia, Radio: RA News. See S 0000.
- 0100 Radio Australia via WRN1 (NAAm): RA News.
- 0100 UK, BBC London (as): World News. See S 0000.
- 0105 UK, BBC London (as): Insight. See T 0105.
- 0110 Australia, Radio: Hindsight. Michelle Rayner presents current events from an historical perspective.
- 0120 UK, BBC London (as): Science in Action. See F 0005.
- 0145 UK, BBC London (as): Off the Shelf. See M 0145.
- 0149 R Slovakia Intl via WRN1 (NAAm): Backpage News.
- 0154 R Slovakia Intl via WRN1 (NAAm): News Summary.

Saturdays

- 0100 Australia, Radio: RA News. See S 0000.
- 0100 Radio Australia via WRN1 (NAAm): RA News.
- 0100 UK, BBC London (as): The World Today. See S 0000.
- 0105 Australia, Radio: Oz Sounds #1. See S 0505.
- 0130 Australia, Radio: Arts Australia. See T 2330.
- 0130 Denmark via WRN1 (NAAm): Copenhagen Calling.
- 0130 Radio Australia via WRN1 (NAAm): Denmark.
- 0130 UK, BBC London (as): Variable Feature. See S 1530.

*It was nice to see a picture in the February issue on page 21 of Rodger Broadbent of Radio Australia — I remember when he was an announcer at Radio Netherlands around 1972, as I remember seeing his picture in one of the Radio Netherlands program guides that were sent out at that time.*

*Maryanne Kehoe, Georgia*



## FREQUENCIES

0200-0300	Anguilla, Caribbean Beacon	6090am				0200-0300	South Korea, R Korea Int'l	7275am	11725am	11810am	15575am
0200-0300 twfha	Argentina, RAE	11710am				0200-0300	Sri Lanka, Sri Lanka BC	6005as	9730as	15425as	
0200-0300 vl	Australia, ABC/Katherine	5025do				0200-0300	Taiwan, Radio Taipei Int'l	5950na	7130as	9680na	11740am
0200-0300 vl	Australia, ABC/Tent Creek	4910do						11825pa	15345as		
0200-0300	Australia, Radio	9660pa	12080as	15240pa	15415as	0200-0300	UK, BBC World Service	5970sa	5975am	6175na	6185am
		15510pa	17715pa	17750as	21725pa			9410as	9605as	9770af	9915sa
0200 0210	Bangladesh, Bangla Betar	4880as						11955as	15280as	15310as	15360as
0200-0230 smwfa	Belarus, R Belarus Int'l	7105eu	7210eu			0200-0300	UK, Merlin Network One	3985eu	9560na		
0200-0300	Bulgaria, Radio	7375na	9485na			0200-0300	USA, KAIJ Dallas TX	5810na			
0200-0300	Canada, CBC N Quebec Svc	9625do				0200-0300	USA, KJES Mesquite NM	7555am			
0200-0300	Canada, CFRX Toronto	6070do				0200-0300	USA, KTBN Salt Lk City UT	7510am			
0200-0300	Canada, CFVP Calgary	6030do				0200-0300	USA, KVOH Los Angeles CA	9975am			
0200-0300	Canada, CHNX Halifax	6130do				0200-0300	USA, KWHR Naalehu HI	17510as			
0200-0300	Canada, CKZN St John's	6160do				0200-0300	USA, Voice of America	7115as	7200as	9740as	9850as
0200-0300	Canada, CKZU Vancouver	6160do						11705as	15250as	15300as	17740as
0200-0259	Canada, R Canada Int'l	6155am	9535am	9755am	9780am			17820as			
		11865am				0200-0300	USA, WBCQ Monticello ME	7415na			
0200-0300	Costa Rica, RF Peace Int'l	6975am	15050am	21460am		0200-0300	USA, WEWN Birmingham AL	5825na	9385eu		
0200-0300	Cuba, Radio Havana	6000na	9820na	11705na	13605na	0200-0300	USA, WGTG McCaysville GA	3270na	5085am		
0200-0300	Ecuador, HCJB	9745na	12015na	21455va		0200-0300	USA, WHRA Greenbush ME	7385af			
0200-0300	Egypt, Radio Cairo	9475na				0200-0300	USA, WHRI Noblesville IN	7315am			
0200-0250	Germany, Deutsche Welle	6035as	7225as	7285as	9615as	0200-0300 twfhfas	USA, WHRI Noblesville IN	5745am			
		9765as	9815as			0200-0300 sm	USA, WHRI Noblesville IN	5755am			
0200-0300	Germany, Overcomer Ministr	5910au				0200-0300	USA, WINB Red Lion PA	11950ca			
0200-0300	Guyana, GBC/Voice of	3290do	5950do			0200-0300	USA, WJCR Upton KY	7490na	13595as		
0200-0300 irreg	Iraq, Radio Iraq Int'l	11785am				0200-0300	USA, WRMI/R Miami Int'l	9955sa			
0200-0300	Kenya, Kenya BC Corp	4935do				0200-0300	USA, WRNO New Orleans LA	7355am			
0200-0300	Malaysia, Radio	7295do				0200-0300 vl	USA, WSHB Cypress Crk SC	5850am	7535am		
0200-0300	Myanmar, Radio	7185do				0200-0300	USA, WWCR Nashville TN	3215na	5070na	5935na	7435na
0200-0300 vl	Nambia, NBC	3270af	3289af			0200-0300	USA, WYFR Okeechobee FL	6065na	9505na		
0200-0300	New Zealand, R NZ Int'l	17675pa				0210-0215 thfa/vl	Kyrgyzstan, Kyrgyz Radio	4010do	4050do		
0200-0230	Pakistan, Radio	15455as				0215-0220	Nepal, Radio	3230as	5005as		
0200-0300 vl	Papua New Guinea, NBC	9675do				0230-0300	Hungary, Radio Budapest	6020na	9835na		
0200-0300	Philippines, FEBC/R Int'l	15450as				0230-0245	Pakistan, Radio	9470as	11975as	13609as	15486as
0200-0300	Romania, R Romania Int'l	5990na	9570na	11740as	11830na	0230-0300 vl	Philippines, R Pilipinas	11805as	15120as	15270as	
		11940as	15380as			0230-0300	Sweden, Radio	7280am	9455am		
0200-0300	Russia, Voice of Russia WS	7180na	9875na	12020na	15595na	0230-0257	Vietnam, Voice of	5940na			
0200-0300	Singapore, R Corp Singapore	6150do				0245-0300	Albania, R Tirana Int	6115na	7160na		
0200-0300 vl	Solomon Islands, SIBC	5020do				0250-0300 sf	Greece, Voice of	7450na	7475na	9375na	9420na
						0250-0300	Vatican State, Vatican R	7305ca	9605am		

## SELECTED PROGRAMS

### Sundays

- 0200 Australia, Radio: RA News. See S 0000.
- 0200 Radio Finland via WRN1 (NAM): News/Weather.
- 0200 UK, BBC London (af/as): The World Today. The World Service breakfast program.
- 0205 Radio Finland via WRN1 (NAM): Capital Cafe.
- 0210 Australia, Radio: Fine Music Australia. The best Australian fine music performances and compositions are presented by Ivar Lloyd.
- 0230 Australia, Radio: Innovations. Desley Blanch reports on Australian inventions and innovative practices.
- 0230 Radio Sweden via WRN1 (NAM): Special Feature (4).
- 0230 Radio Sweden via WRN1 (NAM): Spectrum (1/3).
- 0230 Radio Sweden via WRN1 (NAM): Sweden Today (2).
- 0230 UK, BBC London (af/as): In Praise of God. Weekly programme of worship and meditation.

### Mondays

- 0200 Australia, Radio: RA News. See S 0000.
- 0200 Radio Finland via WRN1 (NAM): News/Weather.
- 0200 UK, BBC London (af/as): The World Today. See S 0200.
- 0208 Radio Finland via WRN1 (NAM): Compass North.
- 0210 Australia, Radio: The World Today. Tony Eastley with current affairs updates.
- 0224 Radio Finland via WRN1 (NAM): Nunti Latini.
- 0230 Radio Sweden via WRN1 (NAM): In Touch with Stockholm #1.
- 0230 Radio Sweden via WRN1 (NAM): Sounds Nordic (2/4).
- 0230 Radio Sweden via WRN1 (NAM): Weekend (3).
- 0230 UK, BBC London (af): Variable Music Feature. Different features of 15, 30, and 45 minutes length with a musical theme.
- 0230 UK, BBC London (as): Everywoman. See S 1130.

### Tuesdays

- 0200 Australia, Radio: RA News. See S 0000.
- 0200 Radio Finland via WRN1 (NAM): News/Weather.
- 0200 UK, BBC London (af/as): The World Today. See S 0200.
- 0209 Radio Finland via WRN1 (NAM): Compass North.
- 0210 Australia, Radio: The World Today. See M 0210.
- 0225 Radio Finland via WRN1 (NAM): Finnish Press Review.
- 0230 Radio Sweden via WRN1 (NAM): Sixty Degrees North.
- 0230 UK, BBC London (af): On Screen. Film reviews and movie news from around the world.

- 0230 UK, BBC London (as): John Peel. See S 0630.
- 0231 Radio Sweden via WRN1 (NAM): News.
- 0246 Radio Sweden via WRN1 (NAM): SportScan.

### Wednesdays

- 0200 Australia, Radio: RA News. See S 0000.
- 0200 Radio Finland via WRN1 (NAM): News/Weather.
- 0200 UK, BBC London (af/as): The World Today. See S 0200.
- 0209 Radio Finland via WRN1 (NAM): Compass North.
- 0210 Australia, Radio: The World Today. See M 0210.
- 0225 Radio Finland via WRN1 (NAM): Finnish Press Review.
- 0230 Radio Sweden via WRN1 (NAM): Sixty Degrees North.
- 0230 UK, BBC London (af): Everywoman. Features and reports on the activities of women across the globe.
- 0230 UK, BBC London (as): The Vintage Chart Show. See M 0530.
- 0231 Radio Sweden via WRN1 (NAM): News.
- 0246 Radio Sweden via WRN1 (NAM): MediaScan (1/3).

### Thursdays

- 0200 Australia, Radio: RA News. See S 0000.
- 0200 Radio Finland via WRN1 (NAM): News/Weather.
- 0200 UK, BBC London (af/as): The World Today. See S 0200.
- 0209 Radio Finland via WRN1 (NAM): Compass North.
- 0210 Australia, Radio: The World Today. See M 0210.
- 0225 Radio Finland via WRN1 (NAM): Finnish Press Review.
- 0230 Radio Sweden via WRN1 (NAM): Sixty Degrees North.
- 0230 UK, BBC London (af): Variable Feature. See M 1445.
- 0230 UK, BBC London (as): Variable Music Feature. See T 0530.
- 0231 Radio Sweden via WRN1 (NAM): News.
- 0243 Radio Sweden via WRN1 (NAM): Nordic Report (1).
- 0246 Radio Sweden via WRN1 (NAM): Horizon (4/5).
- 0246 Radio Sweden via WRN1 (NAM): Money Matters (2).
- 0247 Radio Sweden via WRN1 (NAM): HeartBeat (3).

### Fridays

- 0200 Australia, Radio: RA News. See S 0000.
- 0200 Radio Finland via WRN1 (NAM): News/Weather.
- 0200 UK, BBC London (af/as): The World Today. See S 0200.
- 0209 Radio Finland via WRN1 (NAM): Compass North.
- 0210 Australia, Radio: The World Today. See M 0210.
- 0225 Radio Sweden via WRN1 (NAM): Finnish Press Review.
- 0230 Radio Sweden via WRN1 (NAM): Sixty Degrees North.

- 0230 UK, BBC London (af/as): Andy Kershaw's World of Music. Recordings of diverse music from around the world.
- 0231 Radio Sweden via WRN1 (NAM): News.

### Saturdays

- 0200 Australia, Radio: RA News. See S 0000.
- 0200 Radio Finland via WRN1 (NAM): News/Weather.
- 0200 UK, BBC London (af/as): The World Today. See S 0200.
- 0205 Australia, Radio: Okham's Razor. See S 0605.
- 0205 Radio Finland via WRN1 (NAM): Feature Stories from Last Week.
- 0224 Radio Finland via WRN1 (NAM): Finnish Press Review.
- 0230 Australia, Radio: Earthbeat. See S 2330.
- 0230 Radio Sweden via WRN1 (NAM): Sixty Degrees North.
- 0230 UK, BBC London (af/as): Jazzmatazz. The request program that lives up to its title.
- 0231 Radio Sweden via WRN1 (NAM): News.
- 0235 Radio Sweden via WRN1 (NAM): Review of the Nordic Newsweek.

## The Beacon Finder

A new directory of VLF/LF/MF Stations commonly logged in North America.

In addition to beacons, this guide lists dozens of utility and experimental stations operating outside the 190-535 kHz range. Comes ready for 3-ring binding.

\$9.95 Postpaid (U.S. funds) from:

**Kevin Carey**

P.O. Box 56, West Bloomfield, NY 14585

FREQUENCIES

0300-0400	Anguilla, Caribbean Beacon	6090am				0300-0400	Uganda, Radio	4976do			
0300-0400 vl	Australia, ABC/Katherine	5025do				0300-0400	UK, BBC World Service	3255af	5975am	6005af	6175na
0300-0400 vl	Australia, ABC/Tent Creek	4910do						6185am	6190af	7160af	9410eu
0300-0400	Australia, Radio	9660pa	12080as	15240pa	15415as			11730af	11760me	11765af	11955as
		15510pa	17715pa	17750as	21725pa			12095af	15310as	15360as	17790as
		14790as						21660as			
0300-0400	Australia, Defense Forces R					0300-0400	UK, Merlin Network One	3985eu	9895eu		
0300-0400 vl	Botswana, Radio	4820do	7255do			0300-0400	Ukraine, R Ukraine Intl	4820eu	6020eu	6030na	6080eu
0300-0400	Canada, CBC N Quebec Svc	9625do						7150na	7205eu	7420eu	9560eu
0300-0400	Canada, CFRX Toronto	6070do						5810na			
0300-0400	Canada, CFVP Calgary	6030do				0300-0400	USA, KAJU Dallas TX	755na			
0300-0400	Canada, CHNX Halifax	6130do				0300-0330	USA, KJES Mesquite NM	7510am			
0300-0400	Canada, CKZN St John's	6160do				0300-0400	USA, KTBN Salt Lk City UT	9975am			
0300-0400	Canada, CKZU Vancouver	6160do				0300-0400	USA, KVOH Los Angeles CA	17510as			
0300-0329 twhfa	Canada, R Canada Intl	6155am	9755am	9780am		0300-0400	USA, KWHR Naalehu HI	6035af	6080af	7105af	7290af
0300-0359 sm	Canada, R Canada Intl	6155am	9755am	9780am		0300-0400	USA, Voice of America	7340af	7415af	9575af	9885af
0300-0356	China, China Radio Intl	9690am						4960af			
0300-0400	Costa Rica, RF Peace Intl	6975am				0300-0330 mtwh	USA, Voice of America	5825na	9385eu		
0300-0400	Cuba, Radio Havana	6000na	9820na	11705na	13605na	0300-0400	USA, WEWN Birmingham AL	3270na	5085am		
0300-0327	Czech Rep, R Prague Intl	7345na	9435na			0300-0400	USA, WGTG McCaysville GA	7385af			
0300-0400	Ecuador, HCJB	9745na	12015na	21455va		0300-0400	USA, WHRA Greenbush ME	7315am			
0300-0330	Egypt, Radio Cairo	9475am				0300-0400	USA, WHRI Noblesville IN	5745am			
0300-0350	Germany, Deutsche Welle	9535am	9640na	9700na	11750na	0300-0400 twhfa	USA, WHRI Noblesville IN	5755am			
0300-0400	Germany, Overcomer Ministr	5910au				0300-0400 sm	USA, WHRI Noblesville IN	11950ca			
0300-0400 vl	Guatemala, Radio Cultural	3300do				0300-0400	USA, WINB Red Lion PA	7490na	13595as		
0300-0400	Guyana, GBC/Voice of	3290do	5950do			0300-0400	USA, WJCR Upton KY	9955sa			
0300-0400	Japan, Radio/NHK	17810as	17825ca	21610pa		0300-0400	USA, WRMI/R Miami Intl	7395am			
0300-0400	Kenya, Kenya BC Corp	4885do	4935do			0300-0400	USA, WRNO New Orleans LA	5850am	7535am		
0300-0400 vl	Lesotho, Radio	4800do				0300-0400 vl	USA, WSHB Cypress Crk SC	2390na	3215na	5070na	5935na
0300-0400	Malaysia, Radio	7295do				0300-0400	USA, WWCN Nashville TN	6065na	9505na		
0300-0330 mtwhfa	Mexico, Radio Mexico Intl	5985na	9705na			0300-0400	USA, WYFR Okeechobee FL	7305ca	9605am		
0300-0355	Moldova, R Moldova Intl	7500na				0300-0310	Vatican State, Vatican R	5905ca			
0300-0400 vl	Namibia, NBC	3270af	3289af			0300-0327	Vietnam, Voice of	6165do	6265do		
0300-0400	New Zealand, R NZ Intl	17675pa				0300-0400	Zambia, Natl BC Corp	3306do	4828do		
0300-0400 vl	Papua New Guinea, NBC	9675do				0300-0400 vl	Zimbabwe, Zimbabwe BC	9660af			
0300-0330 vl	Philippines, R Pilipinas	11805as	15120as	15270as		0310-0340	Vatican State, Vatican R	6115na	7160na		
0300-0400	Russia, Voice of Russia WS	7125na	7180na	9850na	9875na	0330-0400	Albania, R Tirana Intl	9585as	11600as		
		12000na	12020na	12040na	13640na	0330-0357	Czech Rep, R Prague Intl	15235va	15415va	15435va	
0300-0330 s	Russia, Voice of Russia WS	12060na				0330-0350 vl	Libya, Voice of Africa	13770as	15330as	17730as	
0300-0325	S Africa, Channel Africa	5955af				0330-0400 vl	Philippines, R Pilipinas	7115na	9435am		
0300-0400	Singapore, R Corp Singapore	6150do				0330-0400	Sweden, Radio	5050af			
0300-0400	Sri Lanka, Sri Lanka BC	6005as	9730as	15425as		0330-0400	Tanzania, Radio	12005na	13675na	15400na	21485na
0300-0400	Taiwan, Radio Taipei Intl	5950na	9680na	11745as	11825as	0330-0400	UAE, Radio Dubai	7450na	9375na	9420na	
		15345as				0340-0350	Greece, Voice of	7245as	9905as	11620as	
0300-0330	Thailand, Radio	9655am	11905am	15460am		0345-0400	Tajikistan, Radio	3330af	6065af		
0300-0400	Turkey, Voice of	7240va	9655va	21715va		0356-0400	Zambia, Christian Voice				

SELECTED PROGRAMS

Sundays

- 0300 Australia, Radio: RA News. See S 0000.
- 0300 Radio Prague via WRN1 (NAM): News.
- 0300 UK, BBC London (af): The World Today. See S 0200.
- 0300 UK, BBC London (as): World News. See S 0000.
- 0304 Radio Prague via WRN1 (NAM): Encore.
- 0305 Australia, Radio: Feedback. Roger Broadbent answers letters and discusses new programs, reception problems, and questions about Australia.
- 0320 UK, BBC London (af): Sports Roundup. The latest sports news.
- 0330 Australia, Radio: Correspondents' Report. See S 0030.
- 0330 R Austria Intl via WRN1 (NAM): A Letter from Austria.
- 0330 UK, BBC London (af): Postmark Africa. Expert answers to any question under the sun.
- 0330 UK, BBC London (as): Wright Round the World. Steve Wright's brand new show with listeners' requests and dedications.
- 0333 R Austria Intl via WRN1 (NAM): Report from Austria.
- 0344 R Austria Intl via WRN1 (NAM): Postbox.

Mondays

- 0300 Australia, Radio: RA News. See S 0000.
- 0300 Radio Prague via WRN1 (NAM): News.
- 0300 UK, BBC London (af): The World Today. See S 0200.
- 0300 UK, BBC London (as): World News. See S 0000.
- 0304 Radio Prague via WRN1 (NAM): The Arts.
- 0305 UK, BBC London (as): Newstalk. See S 1405.
- 0310 Australia, Radio: Australia Talks Back. Australians talking about issues of the day with Sandy McCutcheon.
- 0312 Radio Prague via WRN1 (NAM): The Magic Carpet.
- 0320 UK, BBC London (af): Sports Roundup. See S 0320.
- 0330 R Austria Intl via WRN1 (NAM): The News from Vienna.
- 0330 UK, BBC London (af): Network Africa. Breakfast show of news, sport, personalities, music, and listener's comments.
- 0333 R Austria Intl via WRN1 (NAM): Report from Austria.
- 0345 UK, BBC London (as): Variable Feature. See S 1530.

Tuesdays

- 0300 Australia, Radio: RA News. See S 0000.
- 0300 Radio Prague via WRN1 (NAM): News.
- 0300 UK, BBC London (af/as): The World Today. See S 0200.
- 0305 Radio Prague via WRN1 (NAM): Current Affairs.
- 0310 Australia, Radio: Australia Talks Back. See M 0310.
- 0317 Radio Prague via WRN1 (NAM): Spotlight.
- 0320 UK, BBC London (af): Sports Roundup. See S 0320.
- 0320 UK, BBC London (as): Outlook. See M 1205.
- 0330 R Austria Intl via WRN1 (NAM): The News from Vienna.
- 0330 UK, BBC London (af): Network Africa. See M 0330.
- 0333 R Austria Intl via WRN1 (NAM): Report from Austria.

Wednesdays

- 0300 Australia, Radio: RA News. See S 0000.
- 0300 Radio Prague via WRN1 (NAM): News.
- 0300 UK, BBC London (af/as): The World Today. See S 0200.
- 0305 Radio Prague via WRN1 (NAM): Current Affairs.
- 0310 Australia, Radio: Australia Talks Back. See M 0310.
- 0318 Radio Prague via WRN1 (NAM): Talking Point.
- 0320 UK, BBC London (af): Sports Roundup. See S 0320.
- 0320 UK, BBC London (as): Outlook. See M 1205.
- 0325 Radio Prague via WRN1 (NAM): Music.
- 0330 R Austria Intl via WRN1 (NAM): The News from Vienna.
- 0330 UK, BBC London (af): Network Africa. See M 0330.
- 0333 R Austria Intl via WRN1 (NAM): Report from Austria.

Thursdays

- 0300 Australia, Radio: RA News. See S 0000.
- 0300 Radio Prague via WRN1 (NAM): News.
- 0300 UK, BBC London (af/as): The World Today. See S 0200.
- 0306 Radio Prague via WRN1 (NAM): Current Affairs.
- 0310 Australia, Radio: Australia Talks Back. See M 0310.
- 0315 UK, BBC London (af/as): Sports Roundup. See S 0405.
- 0318 Radio Prague via WRN1 (NAM): History/Czech.

- 0330 R Austria Intl via WRN1 (NAM): The News from Vienna.
- 0330 UK, BBC London (af): Network Africa. See M 0330.
- 0330 UK, BBC London (as): From Our Own Correspondent. See S 0005.
- 0333 R Austria Intl via WRN1 (NAM): Report from Austria.

Fridays

- 0300 Australia, Radio: RA News. See S 0000.
- 0300 Radio Prague via WRN1 (NAM): News.
- 0300 UK, BBC London (af/as): The World Today. See S 0200.
- 0306 Radio Prague via WRN1 (NAM): Current Affairs.
- 0310 Australia, Radio: Australia Talks Back. See M 0310.
- 0317 Radio Prague via WRN1 (NAM): Economic Report.
- 0320 UK, BBC London (af): Sports Roundup. See S 0320.
- 0320 UK, BBC London (as): Outlook. See M 1205.
- 0325 Radio Prague via WRN1 (NAM): Music.
- 0330 R Austria Intl via WRN1 (NAM): The News from Vienna.
- 0330 UK, BBC London (af): Network Africa. See M 0330.
- 0333 R Austria Intl via WRN1 (NAM): Report from Austria.

Saturdays

- 0300 Australia, Radio: RA News. See S 0000.
- 0300 Radio Prague via WRN1 (NAM): News.
- 0300 UK, BBC London (af/as): The World Today. See S 0200.
- 0305 Australia, Radio: Book Reading. See F 2305.
- 0306 Radio Prague via WRN1 (NAM): Current Affairs.
- 0315 Australia, Radio: Lingua Franca. Words and their stories.
- 0318 Radio Prague via WRN1 (NAM): Postbag.
- 0320 UK, BBC London (af): Sports Roundup. See S 0320.
- 0320 UK, BBC London (as): Outlook. See M 1205.
- 0330 Australia, Radio: Rural Reporter. See W 2330.
- 0330 R Austria Intl via WRN1 (NAM): The News from Vienna.
- 0330 UK, BBC London (af): People and Politics. Background to the British political scene.
- 0333 R Austria Intl via WRN1 (NAM): Report from Austria.



## FREQUENCIES

0400-0500	Anguilla, Caribbean Beacon	6090am				0400-0500	UK, BBC World Service	3255af	3955eu	5975am	6005af
0400-0430	Armenia, Voice of	4810va						6175na	6180eu	6185am	6190af
0400-0500 vl	Australia, ABC/Katherine	5025dc						6195eu	7160af	9410eu	11760me
0400-0500 vl	Australia, ABC/Tent Creek	4910dc						11765af	11955as	12095af	15280as
0400-0500	Australia, Radio	9660pa	12080as	15240pa	15415as			15310as	15420af	15575as	17760as
		15510pa	17715pa	17750as	21725pa			17790as	21660as		
0400-0500	Australia, Defense Forces R	14790es				0400-0500	UK, Merlin Network One	3985eu			
0400-0500 vl	Botswana, Radio	4820dc	7255do			0400-0500	USA, KAUJ Dallas TX	5810na			
0400-0500	Canada, CBC N Quebec Svc	9625da				0400-0500	USA, KTFN Salt Lk City UT	7510am			
0400-0500	Canada, CFRX Toronto	6070dc				0400-0500	USA, KVOH Los Angeles CA	9975am			
0400-0500	Canada, CFVP Calgary	6030dc				0400-0500	USA, KWHR Naalehu HI	17780as			
0400-0500	Canada, CHNX Halifax	6130dc				0400-0500	USA, Voice of America	6035af	6080af	7170af	7290af
0400-0500	Canada, CKZN St John's	6160dc						7415af	9575af	9775af	9885af
0400-0500	Canada, CKZV Vancouver	6160dc				0400-0500	USA, WBQC Monticello ME	7415na			
0400-0429	Canada, R Canada Intl	6150me	9505me	9645me		0400-0500	USA, WEWN Birmingham AL	5825na	9385eu		
0400-0456	China, China Radio Intl	9730am				0400-0500	USA, WGTG Mc Caysville GA	3270na	5085am		
0400-0500	Costa Rica, RF Peace Intl	6975am				0400-0500	USA, WHRA Greenbush ME	7385af			
0400-0500	Cuba, Radio Havana	6000na	9820na	13605na		0400-0500	USA, WHRI Noblesville IN	5755am	7315am		
0400-0427	Czech Rep, R Prague Intl	9955na				0400-0500	USA, WJCR Upton KY	7490na	13595as		
0400-0500	Ecuador, H.CJB	9745na	12015na	21455va		0400-0500 stwhfa	USA, WRMI/R Miami Intl	9955sa			
0400-0450	Germany, Deutsche Welle	6015af	6065af	7225af	7280af	0400-0500	USA, WRNO New Orleans LA	7395am			
		9565af				0400-0500 vl	USA, WSHB Cypress Crk SC	7535eu	12020af		
0400-0500	Guyana, GBC/Voice of	3290dc	5950do			0400-0445	USA, WYFR Okeechobee FL	6065na	9505na	9985eu	
0400-0415	Israel, Kol Israel	7465eu	9435va	21620va		0400-0425	Vietnam, Voice of	5940na	7270na	7400na	9840na
0400-0500	Kenya, Kenya BC Corp	4885dc	4935do					12019na			
0400-0500 vl	Lesotho, Radio	4800dc				0400-0500	Zambia, Christian Voice	3330af	6065af		
0400-0410 vl/m-f	Malawi, MBC	5993dc				0400-0500	Zambia, Natl BC Corp	6165do	6265do		
0400-0500	Malaysia, Radio	7295dc				0400-0500 vl	Zimbabwe, Zimbabwe BC	3306do	4828do		
0400-0430	Mexico, Radio Mexico Intl	5985na	9705na			0405-0500	USA, WWCR Nashville TN	2390na	3210na	5070na	5835na
0400-0425	Moldova, R Moldova Intl	7500na				0415-0440 vl	Italy, RAI Intl	5975af	7235af		
0400-0500	New Zealand, R NZ Intl	17675pa				0430-0500 as/vl	Italy, IRRS	7125va			
0400-0500 vl	Papua New Guinea, NBC	9675dc				0430-0500 a	Kyrgyzstan, Kyrgyz Radio	4010do	4050do		
0400-0500	Romania, R Romania Intl	9570na	11940na	15325as	17720as	0430-0455	Moldova, R Moldova Intl	7500na			
0400-0500	Russia, Voice of Russia WS	7125na	7180na	9850na	12000na	0430-0500	Netherlands, Radio	6165na	9590na		
		12020na	12040na	13640na		0430-0500 vl	Nigeria, Radio/Ibadan	6050do			
0400-0430	S Africa, Channel Africa	5955af				0430-0500 vl	Nigeria, Radio/Kaduna	4770do			
0400-0500	Singapore, R Corp Singapore	6150dc				0430-0500	Nigeria, Radio/Lagos	3326do			
0400-0430	Sri Lanka, Sri Lanka BC	6005as	9730as	15425as		0430-0500	Swaziland, Trans World R	3200af	4775af		
0400-0430	Switzerland, Swiss R Intl	6165eu				0430-0500 mtwhfa	UK, BBC European Service	3955eu	6180eu	6195eu	9410eu
0400-0500	Switzerland, Swiss R Intl	9895na	9905na			0430-0500 s	UK, BBC World Service	3955eu	6180eu	6195eu	9410eu
0400-0430	Tanzania, Radio	5050af				0455-0500	Nigeria, Voice of	7255af	15120va		
0400-0500	Uganda, Radio	4976do									

## SELECTED PROGRAMS

### Sundays

- 0400 Australia, Radio: RA News. See S 0000.
- 0400 Polish Radio Warsaw via WRN1 (NAM): The News from Poland.
- 0400 UK, BBC London (af): The World Today. See S 0200.
- 0400 UK, BBC London (as): World News. See S 0000.
- 0405 Australia, Radio: Pacific Focus. Coverage of issues of relevance to people of the Pacific region.
- 0405 UK, BBC London (as): Sports Roundup. The latest sports news.
- 0415 UK, BBC London (as): Concert Hall. Classical music concerts.
- 0423 Polish Radio Warsaw via WRN1 (NAM): Europe East.
- 0433 Australia, Radio: The Week's End. News headlines and reports from across the continent.
- 0430 Radio Budapest via WRN1 (NAM): News.
- 0430 UK, BBC London (af): Art Beat. A new arts program for Africa.
- 0435 Radio Budapest via WRN1 (NAM): Insight.

### Mondays

- 0400 Australia, Radio: RA News. See S 0000.
- 0400 Polish Radio Warsaw via WRN1 (NAM): The News from Poland.
- 0400 UK, BBC London (af): The World Today. See S 0200.
- 0400 UK, BBC London (as): World News. See S 0000.
- 0404 Polish Radio Warsaw via WRN1 (NAM): Panorama.
- 0405 UK, BBC London (as): Sports Roundup. See S 0405.
- 0410 Australia, Radio: The World Today (repeat). See M 0210.
- 0415 UK, BBC London (as): Westway Access. Explaining the soap opera as an English learning tool.
- 0430 Radio Budapest via WRN1 (NAM): News.
- 0430 UK, BBC London (af): Network Africa. See M 0330.
- 0430 UK, BBC London (as): Meridian Feature. A kaleidoscope of events in the world of the arts.
- 0435 Radio Budapest via WRN1 (NAM): The Classical Touch.

### Tuesdays

- 0400 Australia, Radio: RA News. See S 0000.
- 0400 Polish Radio Warsaw via WRN1 (NAM): The News from Poland.
- 0400 UK, BBC London (af): The World Today. See S 0200.
- 0400 UK, BBC London (as): World News. See S 0000.
- 0405 UK, BBC London (as): Sports Roundup. See S 0405.
- 0410 Australia, Radio: The World Today (repeat). See M 0210.
- 0415 UK, BBC London (as): Westway. The World Service's first-ever

- regular drama (soap opera) serial.
- 0430 Radio Budapest via WRN1 (NAM): Hungary Today.
- 0430 UK, BBC London (af): Network Africa. See M 0330.
- 0430 UK, BBC London (as): On Screen. Film reviews and movie news from around the world.

### Wednesdays

- 0400 Australia, Radio: RA News. See S 0000.
- 0400 Polish Radio Warsaw via WRN1 (NAM): The News from Poland.
- 0400 UK, BBC London (af): The World Today. See S 0200.
- 0400 UK, BBC London (as): Sports Roundup. See S 0000.
- 0405 UK, BBC London (as): Sports Roundup. See S 0405.
- 0410 Australia, Radio: The World Today (repeat). See M 0210.
- 0415 UK, BBC London (as): Short Story. See S 1615.
- 0423 Polish Radio Warsaw via WRN1 (NAM): Letter from Poland.
- 0430 Radio Budapest via WRN1 (NAM): Hungary Today.
- 0430 UK, BBC London (af): Network Africa. See M 0330.
- 0430 UK, BBC London (as): Meridian Live. What's happening in the arts round the world with a roundup of theatre in London.

### Thursdays

- 0400 Australia, Radio: RA News. See S 0000.
- 0400 Polish Radio Warsaw via WRN1 (NAM): The News from Poland.
- 0400 UK, BBC London (af): The World Today. See S 0200.
- 0400 UK, BBC London (as): World News. See S 0000.
- 0405 UK, BBC London (as): Sports Roundup. See S 0405.
- 0410 Australia, Radio: The World Today (repeat). See M 0210.
- 0415 UK, BBC London (as): Westway. See T 0415.
- 0423 Polish Radio Warsaw via WRN1 (NAM): Timeout for Polish 7.
- 0430 Radio Budapest via WRN1 (NAM): Hungary Today.
- 0430 UK, BBC London (af): Network Africa. See M 0330.
- 0430 UK, BBC London (as): Meridian Books. A discussion of a current book of note.

### Fridays

- 0400 Australia, Radio: RA News. See S 0000.
- 0400 Polish Radio Warsaw via WRN1 (NAM): The News from Poland.
- 0400 UK, BBC London (af): The World Today. See S 0200.
- 0400 UK, BBC London (as): World News. See S 0000.
- 0405 UK, BBC London (as): Sports Roundup. See S 0405.

- 0410 Australia, Radio: The World Today (repeat). See M 0210.
- 0415 UK, BBC London (as): Performance. John Stearne explores each week one of the great voices of the century.
- 0420 Polish Radio Warsaw via WRN1 (NAM): A Day in the Life Of.
- 0430 Radio Budapest via WRN1 (NAM): Hungary Today.
- 0430 UK, BBC London (af): Network Africa. See M 0330.
- 0430 UK, BBC London (as): Music Review. News and views from the world of music.

### Saturdays

- 0400 Australia, Radio: RA News. See S 0000.
- 0400 Polish Radio Warsaw via WRN1 (NAM): The News from Poland.
- 0400 UK, BBC London (af): The World Today. See S 0200.
- 0400 UK, BBC London (as): World News. See S 0000.
- 0405 Australia, Radio: Pacific Focus. See S 0405.
- 0405 UK, BBC London (as): Sports Roundup. See S 0405.
- 0415 UK, BBC London (as): Letter from America. Alistair Cooke shares his inimitable view of contemporary American life.
- 0423 Polish Radio Warsaw via WRN1 (NAM): Business Week.
- 0430 Australia, Radio: Asia Pacific. See M 1110.
- 0430 Radio Budapest via WRN1 (NAM): News.
- 0430 UK, BBC London (af): This Week and Africa. A roundup of the week's political developments across the continent.
- 0430 UK, BBC London (as): Composer of the Month. In depth looks at classical composers and their music. A different composer is featured each month.
- 0435 Radio Budapest via WRN1 (NAM): Hungary Today.

## HAUSER'S HIGHLIGHTS ALASKA: KNLS

For the A-99 season, KNLS is using 9615 kHz for most of its broadcasts, including English both at 0800-0900 and 1300-1400

FREQUENCIES

0500-0600	Anguilla, Caribbean Beacon	6090am				0500-0600	Spain, R Exterior Espana	6055am			
0500-0600 vl	Australia, ABC/Katherine	5025do				0500-0600	Swaziland, Trans World R	3200af	4775af		
0500-0600 vl	Australia, ABC/Tent Creek	4910do				0500-0600	Uganda, Radio	4976do			
0500-0600	Australia, Radio	9660pa	12080as	15240pa	15510pa	0500-0600	UK, BBC World Service	5975am	6005af	6175am	6180eu
		17715pa	21820pa					6190af	6195eu	7160af	9410eu
		4820do	7255do					9740as	11760me	11765af	11955pa
0500-0600 vl	Botswana, Radio							12095eu	15280as	15310as	15360as
0500-0600	Canada, CBC N Quebec Vsc	9625do						15420af	15575as	17640af	17760as
0500-0600	Canada, CFRX Toronto	6070do						17790as	17885af	21660as	
0500-0600	Canada, CFVX Calgary	6030do						3985eu	9895eu		
0500-0600	Canada, CHNX Halifax	6130do				0500-0600	UK, Merlin Network One	5810na			
0500-0600	Canada, CKZU Vancouver	6160do				0500-0600	USA, KAIJ Dallas TX	7510am			
0500-0600	China, China Radio Intl	9560na				0500-0600	USA, KTBN Salt Lk City UT	17780as			
0500-0600	Costa Rica, RF Peace Intl	6975am				0500-0600	USA, KWHR Naalehu HI				
0500-0600	Cuba, Radio Havana	9550na	9820na	9830na		0500-0600	USA, Voice of America	5970af	6035af	6080af	7170af
0500-0600	Ecuador, HCJB	9745na	12015na	21455va				7295af	9700af	9775af	11825af
0500-0550	Germany, Deutsche Welle	6100na	6120na	6185na	11795na			12080af	15205me		
0500-0600	Guyana, GBC/Voice of	3290do	5950do			0500-0600	USA, WBCQ Monticello ME	7415na			
0500-0600 as/vl	Italy, IRRS	7125va				0500-0600	USA, WEWN Birmingham AL	5825na	9385na		
0500-0600	Japan, Radio/NHK	6110na	7230eu	9835na	11715as	0500-0600	USA, WGTG McCaysville GA	3270na	5085am		
		11760as	11840as	11850pa	15230pa	0500-0600	USA, WHRA Greenbush ME	7435af			
		15310sa	15590as			0500-0600	USA, WHRI Noblesville IN	5755am	7315am		
		4885do	4935do			0500-0600	USA, WINB Red Lion PA	11950am			
0500-0600	Kenya, Kenya BC Corp	15110as				0500-0600	USA, WJCR Upton KY	7490na	13595as		
0500-0600	Kuwait, Radio	4800do				0500-0600	USA, WRNO New Orleans LA	7395am			
0500-0600 vl	Lesotho, Radio	5100do				0500-0600 vl	USA, WSHB Cypress Crk SC	7535eu	9835af	12020af	
0500-0600	Liberia, LCN/R Liberia Int	5993do				0500-0600	USA, WWCR Nashville TN	2390na	3210na	5070na	5935na
0500-0510 vl/m-f	Malawi, MBC	7295do				0500-0600	USA, WYFR Okeechobee FL	5985na	9985eu	11550eu	
0500-0600	Malaysia, Radio	7160do				0500-0520	Vatican State, Vatican R	4005eu	5883eu	7250eu	
0500-0600	Malaysia, RTM Sarawak	6175as	9750as	15295au		0500-0530	Vatican State, Vatican R	7360af	9660af	11625af	
0500-0600	Malaysia, Voice of	3270af	3289af			0500-0600	Zambia, Christian Voice	6165do	6265do		
0500-0600 vl	Namibia, NBC	6165na	9590na			0500-0600	Zambia, Natl BC Corp	3300af	6065af		
0500-0525	Netherlands, Radio	17675pa				0500-0600	Zimbabwe, Natl BC Corp	3306do	4828do		
0500-0600	New Zealand, R NZ Intl	6050do				0500-0530 vl	Zimbabwe, Zimbabwe BC	4775af	9500af		
0500-0600 vl	Nigeria, Radio/Ibadan	4770do				0500-0600	Swaziland, Trans World R	6015na	6155eu	13730eu	15410me
0500-0600 vl	Nigeria, Radio/Kaduna	3326do				0530-0600	Austria, R Austria Intl	17870me			
0500-0600	Nigeria, Radio/Lagos	7255af	15120va			0530-0600 vl	Ghana, Ghana BC Corp	3366do	4915do		
0500-0600	Nigeria, Voice of	11710eu	13790as			0530-0600 mtwhfa	Malta, VO Mediterranean	7155eu			
0500-0600	North Korea, R Pyongyang	9675do				0530-0600	Switzerland, Swiss R Intl	6165eu			
0500-0600 vl	Papua New Guinea, NBC	15460au	15525au	17570au	17665au	0530-0600	Thailand, Radio	9955eu	11905eu	15115eu	
0500-0600	Russia, Voice of Russia WS	21790au	6100af			0530-0600	UAE, Radio Dubai	15435au	17830au	21605au	21700au
		5960af				0530-0600	UK, BBC European Service	3955eu	6180eu	6195eu	9410eu
0500-0530	S Africa, AWR Africa	15215af						12095eu			
0500-0530	S Africa, Channel Africa	6150do				0530-0600 as	UK, BBC World Service	3955eu	6180eu	6195eu	9410eu
0500-0600	Singapore, R Corp Singapore	5020do						12095eu			
0500-0600 vl	Solomon Islands, SIBC					0530-0600 vl	Zimbabwe, Zimbabwe BC	4828do	5012do		

SELECTED PROGRAMS

Sundays

- 0500 Australia, Radio: RA News. See S 0000.
- 0500 RTE Dublin via WRN1 (NAM): Ireland RTE Dublin.
- 0500 RTE Dublin via WRN1 (NAM): News.
- 0500 UK, BBC London (af/as): The World Today. See S 0200.
- 0502 RTE Dublin via WRN1 (NAM): The Irish Collection.
- 0505 Australia, Radio: Oz Sounds #1. Twenty minutes of music selections by Radio Australia announcers.
- 0530 Australia, Radio: Pacific Review. New program - no information available.
- 0530 UK, BBC London (af): Agenda. This series examines the latest ideas and trends.
- 0530 UK, BBC London (as): Westway Compilation Edition. Catch up on the week's episodes of the World Service's drama serial.

Mondays

- 0500 Australia, Radio: RA News. See S 0000.
- 0500 RTE Dublin via WRN1 (NAM): Ireland RTE Dublin.
- 0500 RTE Dublin via WRN1 (NAM): News.
- 0500 UK, BBC London (af/as): The World Today. See S 0200.
- 0502 RTE Dublin via WRN1 (NAM): The Irish Collection.
- 0510 Australia, Radio: Pacific Beat. The magazine that provides a focus on the people and issues of the region.
- 0530 Australia, Radio: Sport. Five or ten minutes of sports news.
- 0530 UK, BBC London (af): Network Africa. See M 0330.
- 0530 UK, BBC London (as): The Vintage Chart Show. Each week a classic Top 20 from the past with Paul Burnett.
- 0540 Australia, Radio: Pacific Beat. See M 0510.

Tuesdays

- 0500 Australia, Radio: RA News. See S 0000.
- 0500 RTE Dublin via WRN1 (NAM): Ireland RTE Dublin.
- 0500 RTE Dublin via WRN1 (NAM): News.
- 0500 UK, BBC London (af/as): The World Today. See S 0200.
- 0502 RTE Dublin via WRN1 (NAM): The Irish Collection.
- 0510 Australia, Radio: Pacific Beat. See M 0510.

- 0530 Australia, Radio: Sport. See M 0530.
- 0530 UK, BBC London (af): Network Africa. See M 0330.
- 0530 UK, BBC London (as): Variable Music Feature. Different features of 15, 30, and 45 minutes length with a musical theme.
- 0540 Australia, Radio: Pacific Beat. See M 0510.

Wednesdays

- 0500 Australia, Radio: RA News. See S 0000.
- 0500 RTE Dublin via WRN1 (NAM): Ireland RTE Dublin.
- 0500 RTE Dublin via WRN1 (NAM): News.
- 0500 UK, BBC London (af/as): The World Today. See S 0200.
- 0502 RTE Dublin via WRN1 (NAM): The Irish Collection.
- 0510 Australia, Radio: Pacific Beat. See M 0510.
- 0530 Australia, Radio: Sport. See M 0530.
- 0530 UK, BBC London (af): Network Africa. See M 0330.
- 0530 UK, BBC London (as): Andy Kershaw's World of Music. Recordings of diverse music from around the world.
- 0540 Australia, Radio: Pacific Beat. See M 0510.

Thursdays

- 0500 Australia, Radio: RA News. See S 0000.
- 0500 RTE Dublin via WRN1 (NAM): Ireland RTE Dublin.
- 0500 RTE Dublin via WRN1 (NAM): News.
- 0500 UK, BBC London (af/as): The World Today. See S 0200.
- 0502 RTE Dublin via WRN1 (NAM): The Irish Collection.
- 0510 Australia, Radio: Pacific Beat. See M 0510.
- 0530 Australia, Radio: Sport. See M 0530.
- 0530 UK, BBC London (af): Network Africa. See M 0330.
- 0530 UK, BBC London (as): Variable Feature. See S 1530.
- 0540 Australia, Radio: Pacific Beat. See M 0510.

Fridays

- 0500 Australia, Radio: RA News. See S 0000.
- 0500 RTE Dublin via WRN1 (NAM): Ireland RTE Dublin.
- 0500 RTE Dublin via WRN1 (NAM): News.
- 0500 UK, BBC London (af/as): The World Today. See S 0200.

- 0502 RTE Dublin via WRN1 (NAM): The Irish Collection.
- 0510 Australia, Radio: Pacific Beat. See M 0510.
- 0530 Australia, Radio: Sport. See M 0530.
- 0530 UK, BBC London (af): Network Africa. See M 0330.
- 0530 UK, BBC London (as): Jazzmatazz. The request program that lives up to its title.
- 0540 Australia, Radio: Pacific Beat. See M 0510.

Saturdays

- 0500 Australia, Radio: RA News. See S 0000.
- 0500 Radio Budapest via WRN1 (NAM): News.
- 0500 RTE Dublin via WRN1 (NAM): Ireland RTE Dublin.
- 0500 UK, BBC London (af/as): The World Today. See S 0200.
- 0502 Radio Budapest via WRN1 (NAM): The Irish Collection.
- 0505 Australia, Radio: Money, Markets, and the Economy. See S 0005.
- 0530 Australia, Radio: Earthbeat. See S 2330.
- 0530 UK, BBC London (af): Talkabout Africa. See W 1615.
- 0530 UK, BBC London (as): The Greenfield Collection. This classical music program replaces Ray on Record.

HAUSER'S HIGHLIGHTS  
KOREA SOUTH: RKI

"Year of Architecture" is 1999 theme of RKI QSL cards issued both for SW and internet "reception" reports (RKI Multiwave Feedback)



## FREQUENCIES

0600-0700	Anguilla, Caribbean Beacon	6090am				0600-0635	S Africa, Trans World R	11735af			
0600-0700 vl	Australia, ABC/Katherine	5025do				0600-0700	Singapore, R Corp Singapore	6150do			
0600-0700 vl	Australia, ABC/Tent Creek	4910do				0600-0700 vl	Solomon Islands, SIBC	5020do			
0600-0700	Australia, Radio	9660pa	12080as	15240pa	15415as	0600-0700	UK, BBC World Service	3955eu	5975am	6005af	6175am
		15510pa	17715pa	17750as	21725pa			6180eu	6190af	6195eu	7145pa
		4820do	4830do	7255do				7160af	7325eu	9410eu	9740as
0600-0700 vl	Botswana, Radio	9625do						11760me	11765af	11940af	11955pa
0600-0700 vl	Canada, CBC N Quebec Svc	6070do						12095eu	15310as	15360as	15420af
0600-0700	Canada, CFRX Toronto	6030do						15565eu	15575as	17640af	17760as
0600-0700	Canada, CFVP Calgary	6130do						17790as	17895af	21660as	
0600-0700	Canada, CHNX Halifax	6160do				0600-0700	UK, Merlin Network One	6110eu			
0600-0700	Canada, CKZU Vancouver	6090va	6150va	9670af	9780va	0600-0700	USA, KALJ Dallas TX	5810na			
0600-0629 mtwhf	Canada, R Canada Intl	11905va				0600-0700	USA, KTVB Salt Lk City UT	7510am			
						0600-0700	USA, KWHR Naalehu HI	17780as			
0600-0700	Costa Rica, RF Peace Intl	6975am				0600-0630	USA, Voice of America	5970af	6035af	6080af	7170af
0600-0700	Cuba, Radio Havana	9550na	9820na	9830na				7285af	11805af	11825eu	11905af
0600-0700	Ecuador, HCJB	9745na	12015na	21455va				12080af	15205me	15600af	
0600-0650	Germany, Deutsche Welle	6045af	17820af	21695af				7415na			
						0600-0700	USA, WBCQ Monticello ME	5825na	9385eu		
						0600-0700	USA, WEWN Birmingham AL	7435af			
						0600-0700	USA, WHRA Greenbush ME	5755am	7315am		
0600-0700 vl	Ghana, Ghana BC Corp	3366do	4915do			0600-0700	USA, WHRI Noblesville IN	11950am			
0600-0700	Guyana, GBC/Voice of	3290do	5950do			0600-0700	USA, WINB Red Lion PA	7490na	13595as		
0600-0700 vl	Italy, IRRS	3985va				0600-0700	USA, WJCR Upton KY	7395am			
0600-0700	Japan, Radio/NHK	5975eu	7230eu	9835na	11740as	0600-0700	USA, WRNO New Orleans LA	2390na	3210na	5070na	5935na
		11840as	11840as	15310sa	15590as	0600-0700	USA, WWCR Nashville TN	5985na	7355eu		
0600-0700	Kenya, Kenya BC Corp	4885do	4935do			0600-0700	USA, WYFR Okeechobee FL	4960do			
0600-0700 vl	Kiribati, Radio	9825do				0600-0700 vl	Vanuatu, Radio	9780do			
0600-0700	Kuwait, Radio	15110as				0600-0700	Yemen, Rep of Yemen Radio	3330af	6065af		
0600-0700 vl	Lesotho, Radio	4800do				0600-0700	Zambia, Christian Voice	6165do	6265do		
0600-0700	Liberia, LCN/R Liberia Int	5100do				0600-0700 vl	Zimbabwe, Zimbabwe BC	4828do	5012do		
0600-0700	Malaysia, Radio	7295do				0605-0610 mtwhfa	Croatia, Croatian Radio	6235eu	7305eu	9830eu	13820au
0600-0700	Malaysia, RTM Sarawak	7160do				0605-0700	Swaziland, Trans World R	6100af	9500af		
0600-0700	Malaysia, Voice of	6175as	9750as	15295au		0610-0615 s	Kyrgyzstan, Kyrgyz Radio	4010do	4050do		
0600-0700 vl	Namibia, NBC	3270af	3289af			0630-0700	Austria, R Austria Intl	6015na			
0600-0700	New Zealand, R NZ Intl	17675pa				0630-0700	Georgia, Georgian Radio	11910eu			
0600-0700 vl	Nigeria, Radio/Ibadan	6050do				0630-0700 mtwhf	UK, BBC European Service	3955eu	6195eu		
0600-0700 vl	Nigeria, Radio/Kaduna	4770do				0630-0700 as	UK, BBC World Service	3955eu	6195eu		
0600-0700	Nigeria, Radio/Lagos	3326do				0630-0700	USA, Voice of America	5995af	7170af	11825eu	11950af
0600-0700	Nigeria, Voice of	7255af	15120va					15205me			
0600-0700 vl	Papua New Guinea, NBC	9675do				0630-0700 as	USA, Voice of America	5970af	6035af	6080af	7285af
0600-0700	Romania, R Romania Intl	7105eu	9510na	9625eu	11775eu			11805af	12080af	15600af	
		17790af	21480na	17495au	17570au	0630-0700	Vatican State, Vatican R	9660af	11625af	13765af	
0600-0700	Russia, Voice of Russia WS	15460au	15525au			0641-0656	Romania, R Romania Intl	9550eu	9625eu	9665eu	11885eu
		17665au	21790au			0645-0655 as	Monaco, Trans World Radio	9870eu			
		15215af				0655-0700 mtwhf	Monaco, Trans World Radio	9870eu			

## SELECTED PROGRAMS

### Sundays

- 0600 Australia, Radio: RA News. See S 0000.
- 0600 Swiss Radio Intl via WRN1 (NAM): World Radio Switzerland
- 0600 UK, BBC London (af): The World Today. See S 0200.
- 0600 UK, BBC London (af): World News. See S 0000.
- 0605 Australia, Radio: Okham's Razor. Robyn Williams with straight, sharp talk about science.
- 0605 UK, BBC London (as): From Our Own Correspondent. See S 0005.
- 0620 UK, BBC London (af): Sports Roundup. See S 0320.
- 0650 Australia, Radio: Correspondents' Report. See S 0030.
- 0650 UK, BBC London (af): Postmark Africa. See S 0330.
- 0650 UK, BBC London (as): John Peel. Tracks from newly released albums and singles from the contemporary music scene.

### Mondays

- 0600 Australia, Radio: RA News. See S 0000.
- 0600 Swiss Radio Intl via WRN1 (NAM): World Radio Switzerland.
- 0600 UK, BBC London (af): The World Today. See S 0200.
- 0600 UK, BBC London (as): World News. See S 0000.
- 0605 UK, BBC London (as): Off the Shelf. See M 0145.
- 0610 Australia, Radio: The Australian Music Show. Kim Taylor presents the music, people, and issues of the Australian contemporary music industry.
- 0620 UK, BBC London (af): Sports Roundup. See S 0320.
- 0625 UK, BBC London (as): My Century. Moments from individuals' lives throughout the 20th century (5 or 30 mins).
- 0630 Australia, Radio: Sports. A half-hour of sports.
- 0630 UK, BBC London (af): Network Africa. See M 0330.
- 0630 UK, BBC London (as): Variable Feature. See S 1530.

### Tuesdays

- 0300 Australia, Radio: RA News. See S 0000.
- 0300 Swiss Radio Intl via WRN1 (NAM): World Radio Switzerland.
- 0300 UK, BBC London (af): The World Today. See S 0200.

- 0600 UK, BBC London (as): World News. See S 0000.
- 0605 UK, BBC London (as): Science View. A look at complex issues and the implications of the latest research findings.
- 0610 Australia, Radio: At Your Request. Dick Paterson plays favorite music.
- 0610 UK, BBC London (as): Off the Shelf. See M 0145.
- 0620 UK, BBC London (af): Sports Roundup. See S 0320.
- 0625 UK, BBC London (as): My Century. See M 0625.
- 0630 Australia, Radio: Sports. See M 0630.
- 0630 UK, BBC London (af): Network Africa. See M 0330.
- 0630 UK, BBC London (as): Multitrack Hit-List. See M 1615.

### Wednesdays

- 0600 Australia, Radio: RA News. See S 0000.
- 0600 Swiss Radio Intl via WRN1 (NAM): World Radio Switzerland.
- 0600 UK, BBC London (af): The World Today. See S 0200.
- 0600 UK, BBC London (as): World News. See S 0000.
- 0605 UK, BBC London (as): Music Brief. A five-minute interlude.
- 0610 Australia, Radio: Blacktracker. Mal Honess with an insight into the music and performance of Australia's aborigines.
- 0610 UK, BBC London (as): Off the Shelf. See M 0145.
- 0620 UK, BBC London (af): Sports Roundup. See S 0320.
- 0625 UK, BBC London (as): My Century. See M 0625.
- 0630 Australia, Radio: Sports. See M 0630.
- 0630 UK, BBC London (af): Network Africa. See M 0330.
- 0630 UK, BBC London (as): Megamix. See T 1615.

### Thursdays

- 0600 Australia, Radio: RA News. See S 0000.
- 0600 Swiss Radio Intl via WRN1 (NAM): World Radio Switzerland.
- 0600 UK, BBC London (af): The World Today. See S 0200.
- 0600 UK, BBC London (as): World News. See S 0000.
- 0605 UK, BBC London (as): Pop Short. A five-minute popular music program.
- 0610 Australia, Radio: Australian Country Style. Graham Bell goes up country.

- 0610 UK, BBC London (as): Off the Shelf. See M 0145.
- 0620 UK, BBC London (af): Sports Roundup. See S 0320.
- 0625 UK, BBC London (as): My Century. See M 0625.
- 0630 Australia, Radio: Sports. See M 0630.
- 0630 UK, BBC London (af): Network Africa. See M 0330.
- 0630 UK, BBC London (as): Multitrack X-Press. See W 1615.

### Fridays

- 0600 Australia, Radio: RA News. See S 0000.
- 0600 Swiss Radio Intl via WRN1 (NAM): World Radio Switzerland.
- 0600 UK, BBC London (af): The World Today. See S 0200.
- 0600 UK, BBC London (as): World News. See S 0000.
- 0605 UK, BBC London (as): Take Five. A short series of human interest stories.
- 0610 Australia, Radio: Music Deli. See M 1605.
- 0610 UK, BBC London (as): Off the Shelf. See M 0145.
- 0620 UK, BBC London (af): Sports Roundup. See S 0320.
- 0625 UK, BBC London (as): My Century. See M 0625.
- 0630 Australia, Radio: Sports. See M 0630.
- 0630 UK, BBC London (af): Network Africa. See M 0330.
- 0630 UK, BBC London (as): Multitrack Alternative. Latest developments on the British music scene.

### Saturdays

- 0600 Australia, Radio: RA News. See S 0000.
- 0600 Swiss Radio Intl via WRN1 (NAM): World Radio Switzerland.
- 0600 UK, BBC London (af): The World Today. See S 0200.
- 0600 UK, BBC London (as): World News. See S 0000.
- 0605 Australia, Radio: Feedback. See S 0305.
- 0605 UK, BBC London (as): Spotlight. Focus on the theater.
- 0610 UK, BBC London (as): The Farming World. See M 0105.
- 0620 UK, BBC London (af): Sports Roundup. See S 0320.
- 0625 UK, BBC London (as): Music Brief. See W 0605.
- 0630 Australia, Radio: Arts Australia. See T 2330.
- 0630 UK, BBC London (af): This Week and Africa. See A 0430.
- 0630 UK, BBC London (as): Omnibus. See M 0030.







FREQUENCIES

Table with columns for frequency, time, and country/station. Includes entries for Anguilla, Australia, Canada, Costa Rica, Ecuador, France, Germany, Ghana, Guyana, Iran, Italy, Japan, Jordan, Kazakhstan, Kenya, Kyrgyzstan, Lesotho, Liberia, Malaysia, Malaysia, N Mariana, Nambia, Netherlands, New Zealand, Nigena, Nigeria, North Korea, Palau, Papua New Guinea, Singapore, Solomon Islands, Switzerland, Taiwan, Tanzania, UK, USA, Vietnam, Zambia, Zimbabwe, Pakistan, Nepal, Kazakhstan, China, Czech Rep, Libya, Netherlands, South Korea, UK, Vatican State, and Kazakhstan.

SELECTED PROGRAMS

Sundays

- 1100 Australia, Radio: RA News. See S 0000.
1100 Swiss Radio Intl via WRN1 (NAM): World Radio Switzerland.
1100 UK, BBC London (af/as): Newdesk. World news and dispatches from overseas and UK correspondents.
1105 Australia, Radio: Jazz Notes. The best of Australian jazz is introduced by Ivan Lloyd.
1130 Australia, Radio: Money, Markets, and the Economy. See S 0005.
1130 UK, BBC London (af): Play of the Week. A different radio drama program each week.
1130 UK, BBC London (as): Everywoman. Features and reports on the activities of women across the globe.
1130 UK, BBC London (as): Play of the Week (EAs). A different radio drama program each week (alternative programming for East Asia).

Mondays

- 1100 Australia, Radio: RA News. See S 0000.
1100 Swiss Radio Intl via WRN1 (NAM): World Radio Switzerland.
1100 UK, BBC London (af/as): Newdesk. See S 1100.
1110 Australia, Radio: Asia Pacific (repeat). News and analysis from across the Pacific and Asia with Di Martin.
1130 Australia, Radio: Sport. See M 0530.
1130 UK, BBC London (af): Meridian Feature. A kaleidoscope of events in the world of the arts.
1130 UK, BBC London (as): Omnibus. See M 0030.
1130 UK, BBC London (as): The Learning Zone (SAs). For people who want to learn more about subjects such as science, health, the world and work and literature while practicing English listening skills.
1135 Australia, Radio: Life Matters. Geraldine Doogue and Norman Swan talk with the main people behind Australia's social policies.

Tuesdays

- 1100 Australia, Radio: RA News. See S 0000.

- 1100 Swiss Radio Intl via WRN1 (NAM): World Radio Switzerland.
1100 UK, BBC London (af/as): Newdesk. See S 1100.
1110 Australia, Radio: Asia Pacific (repeat). See M 1110.
1130 Australia, Radio: Sport. See M 0530.
1130 UK, BBC London (af): Composer of the Month. In depth looks at classical composers and their music. A different composer is featured each month.
1130 UK, BBC London (as): On Screen. See T 0430.
1130 UK, BBC London (as): The Learning Zone (SAs). See M 1130.
1135 Australia, Radio: Life Matters. See M 1135.

Wednesdays

- 1100 Australia, Radio: RA News. See S 0000.
1100 Swiss Radio Intl via WRN1 (NAM): World Radio Switzerland.
1100 UK, BBC London (af/as): Newdesk. See S 1100.
1110 Australia, Radio: Asia Pacific (repeat). See M 1110.
1130 Australia, Radio: Sport. See M 0530.
1130 Radio Finland via WRN1 (NAM): News/Weather.
1130 UK, BBC London (af): Meridian Live. What's happening in the arts round the world with a roundup of theatre in London.
1130 UK, BBC London (as): Meridian Live. See W 0430.
1130 UK, BBC London (as): The Learning Zone (SAs). See M 1130.
1135 Australia, Radio: Life Matters. See M 1135.
1138 Radio Finland via WRN1 (NAM): Compass North.
1154 Radio Finland via WRN1 (NAM): Finnish Press Review.

Thursdays

- 1100 Australia, Radio: RA News. See S 0000.
1100 Swiss Radio Intl via WRN1 (NAM): World Radio Switzerland.
1100 UK, BBC London (af/as): Newdesk. See S 1100.
1110 Australia, Radio: Asia Pacific (repeat). See M 1110.
1130 Australia, Radio: Sport. See M 0530.
1130 UK, BBC London (af/as): Meridian Books. A discussion of a current book of note.
1130 UK, BBC London (as): The Learning Zone (SAs). See M 1130.
1135 Australia, Radio: Life Matters. See M 1135.

- 1145 UK, BBC London (as): Network II (SAs). Learning through the Internet.

Fridays

- 1100 Australia, Radio: RA News. See S 0000.
1100 Swiss Radio Intl via WRN1 (NAM): World Radio Switzerland.
1100 UK, BBC London (af/as): Newdesk. See S 1100.
1110 Australia, Radio: Asia Pacific (repeat). See M 1110.
1130 Australia, Radio: Sport. See M 0530.
1130 R Vlaanderen Intl via WRN1 (NAM): Brussels Calling.
1130 Radio Finland via WRN1 (NAM): News/Weather.
1130 UK, BBC London (af/as): Music Review. News and views from the world of music.
1130 UK, BBC London (as): The Learning Zone (SAs). See M 1130.
1131 R Vlaanderen Intl via WRN1 (NAM): News.
1135 Australia, Radio: Life Matters. See M 1135.
1138 Radio Finland via WRN1 (NAM): Compass North.
1154 Radio Finland via WRN1 (NAM): Finnish Press Review.

Saturdays

- 1100 Australia, Radio: RA News. See S 0000.
1100 Swiss Radio Intl via WRN1 (NAM): World Radio Switzerland.
1100 UK, BBC London (af/as): Newdesk. See S 1100.
1105 Australia, Radio: Fine Music Australia. See S 0210.
1125 Swiss Radio Intl via WRN1 (NAM): Network Plus.
1125 Swiss Radio Intl via WRN1 (NAM): World Radio Network.
1130 Australia, Radio: Book Reading. See F 2305.
1130 R Vlaanderen Intl via WRN1 (NAM): Brussels Calling.
1130 Radio Finland via WRN1 (NAM): News/Weather.
1130 UK, BBC London (af): African Perspective. See T 1615.
1130 UK, BBC London (as): My Century. See M 0625.
1131 R Vlaanderen Intl via WRN1 (NAM): News.
1134 R Vlaanderen Intl via WRN1 (NAM): Press Review.
1135 Radio Finland via WRN1 (NAM): Feature Stories from Last Week.
1139 R Vlaanderen Intl via WRN1 (NAM): Music from Flanders.
1145 Australia, Radio: Lingua Franca. See A 0315.
1153 Radio Finland via WRN1 (NAM): Nunt: Latin.



## FREQUENCIES

1200-1300	Anguilla, Caribbean Beacon	11775am						1200-1300 as	Tanzania, Radio	5050af				
1200-1300 vl	Australia, ABC/Alice Spgs	2310do						1200-1300	UK, BBC World Service	5965na	6190af	6195va	9410eu	
1200-1300 vl	Australia, ABC/Katherine	2485do								9515na	11760me	11940af	12095eu	
1200-1300 vl	Australia, ABC/Tent Creek	2325do								15220am	15310as	17640eu	17705eu	
1200-1300	Australia, Radio	6020pa	6080as	9580pa						17785as	17830as	17885af	21660af	
1200-1300 vl	Botswana, Radio	4820do	4830do	7255do				1200-1215 mtwhf	UK, BBC World Service	9580as	9740as	11955as	15280as	
1200-1300	Brazil, R Nacional Bras	15445am						1200-1300	UK, Merlin Network One	9915eu	13645eu	17630eu	21550af	
1200-1215	Cambodia, Natl Radio Of	11940as						1200-1300	USA, KAU Dallas TX	5810va				
1200-1300 vl	Canada, CBC N Quebec Svc	9625do						1200-1300	USA, KTBN Salt Lk City UT	7510am				
1200-1300	Canada, CFRX Toronto	6070do						1200-1300	USA, KWHR Naaleu HI	9930as	11565pa			
1200-1300	Canada, CFVP Calgary	6030do						1200-1300	USA, Voice of America	6110as	9645as	9760as	11705as	
1200-1300	Canada, CHNX Halifax	6130do								11715as	15425as			
1200-1300	Canada, CKZN St John's	6160do						1200-1300	USA, WEWN Birmingham AL	11875na	15745va			
1200-1300	Canada, CKZU Vancouver	6160do						1200-1300	USA, WHRI Noblesville IN	6040am	9495am			
1200-1229	Canada, R Canada Intl	6150as	11730as					1200-1300	USA, WJCR Upton KY	7490na	13595as			
1200-1256	China, China Radio Intl	6950pa	6955as	7385pa	9565as			1200-1300	USA, WRMI/R Miami Intl	9955am				
		9715as	11660as	11675pa	11980as			1200-1300	USA, WRNO New Orleans LA	7395am				
		6995as	11700as	12110as				1200-1300 vl	USA, WSHB Cypress Crk SC	6095am	9455am			
1200-1230 vl	China, China Radio Intl	12005am	15115am	21455va				1200-1300	USA, WWCR Nashville TN	5070na	7435na	13845na	15685na	
1200-1300	Ecuador, HCJB	15186af						1200-1245	USA, WYFR Okeechobee FL	5950na	7355na	11830na	11970na	
1200-1300 as/vl	Eq Guinea, R East Africa	11600as	15155eu					1200-1228	Uzbekistan, R Tashkent	5060as	5975as	6025as	9715as	
1200-1257	France, Radio France Intl	5850eu						1200-1300	Zambia, Christian Voice	6065af				
1200-1300	Germany, Sunrse Radio	4915do						1200-1300	Zambia, Natl BC Corp	6165do	6265do			
1200-1300 vl	Ghana, Ghana BC Corp	3290do	5950do					1200-1300 vl	Zimbabwe, Zimbabwe BC	4828do	5012do			
1200-1300	Guyana, GBC/Voice of	4760do						1205-1210	Croatia, Croatian Radio	6165eu	7185eu	9830eu		
1200-1210	India, All India Radio	11830as	11875as	13605as	15255as			1206-1300 occsnal	New Zealand, R NZ Intl	6105pa				
1200-1230	Iran, VOIRI	17560as						1209-1215 mtwhf	UK, BBC Caribbean Report	6195ca	15220ca			
		7120va						1209-1215 as	UK, BBC World Service	15220am				
1200-1300 as/vl	Italy, IRRS	11690eu						1215-1300	Egypt, Radio Cairo	17595as				
1200-1300	Jordan, Radio	4935do						1230-1300	Bangladesh, Bangla Betar	7185as	9548as			
1200-1300	Kenya, Kenya BC Corp	4800do						1230-1257	Czech Rep, R Prague Intl	6055eu	21745as			
1200-1300 vl	Lesotho, Radio	7295do						1230-1300	Guam, AWR/KSDA	15225as				
1200-1300	Malaysia, Radio	5980do						1230-1300	Italy, AWR Europe	7230as				
1200-1300 vl	Malaysia, RTM Kota Kinabalu	9355as						1230-1300	Mongolia, Voice of	12085au				
1200-1300 vl	N Mariana Is, KHBI Saipan	6060af	6175af					1230-1300	Serbia, Radio Yugoslavia	11835au				
1200-1300 vl	Namibia, NBC	6045eu	9855eu					1230-1300	South Korea, R Korea Intl	6055as	9570as	13670as		
1200-1300	Netherlands, Radio	9700pa						1230-1300	Sri Lanka, Sri Lanka BC	6005as	9730as	15425as		
1200-1205 occsnal	New Zealand, R NZ Intl	6050do						1230-1300	Sweden, Radio	15240am	17870am	21810am		
1200-1300 vl	Nigeria, Radio/Ibadan	4770do						1230-1300	Thailand, Radio	9655as	9810as	11905as		
1200-1300 vl	Nigeria, Radio/Kaduna	9955as	9965as	9985as				1230-1300	Turkey, Voice of	15295as	17815as			
1200-1300	Palau, KHBN/Voice of Hope	4890do						1230-1255	Vietnam, Voice of	5940as	7270as	7400as	9840as	
1200-1300 m-a/vl	Papua New Guinea, NBC	6095eu	7270eu	9525eu	11820eu					12020as				
1200-1255	Poland, Polish R Warsaw	6015as	6150as					1240-1250	Greece, Voice of	15630af				
1200-1300	Singapore, R Singapore Intl	9535eu						1240-1255 smtwh	UK, BBC Slow Speed News	7140me	11820me	13660af	15180af	
1200-1230	Switzerland, Swiss R Intl	9610au								15555me	17585af			
1200-1300	Taiwan, Radio Taipei Intl							1245-1300	USA, WYFR Okeechobee FL	5950na	11830na	11970na		

## SELECTED PROGRAMS

### Sundays

- 1200 Australia, Radio: RA News. See S 0000.
- 1200 Radio Australia via WRN1 (NAM): RA News.
- 1200 UK, BBC London (af): Play of the Week (from 1130). See S 1130.
- 1200 UK, BBC London (as): Play of the Week (from 1130) (EAs). A different radio drama program each week.
- 1200 UK, BBC London (as): World News. See S 0000.
- 1205 Australia, Radio: Country Club (Part 1). ABC's program of contemporary and traditional country music with Richard Partridge (1st Hour).
- 205 UK, BBC London (as): From Our Own Correspondent. See S 0005.
- 230 UK, BBC London (af): Letter from America. Alistair Cooke shares his inimitable view of contemporary American life.
- 1230 UK, BBC London (as): Waveguide (4). The latest information on international broadcasting with reviews of receivers and news about reception.
- 1230 UK, BBC London (as): Write On. Air your views about World Service; write to PO Box 76, Bush House, Strand, London WC2B 4PH.
- 1235 Radio Australia via WRN1 (NAM): Asia Pacific.
- 1245 UK, BBC London (af/as): Sports Roundup. See S 0320.

### Mondays

- 1200 Australia, Radio: RA News. See S 0000.
- 1200 Radio Australia via WRN1 (NAM): RA News.
- 1200 UK, BBC London (af/as): World News. See S 1400.
- 1205 Australia, Radio: Late Night Live. Topical, political, cultural and philosophical issues with Phillip Adams of Radio National.
- 1205 UK, BBC London (af/as): Outlook. An up-to-the-minute mix of conversation, controversy and color from around the world.
- 1245 UK, BBC London (af/as): Sports Roundup. See S 0320.

### Tuesdays

- 1200 Australia, Radio: RA News. See S 0000.

- 1200 Radio Australia via WRN1 (NAM): RA News.
- 1200 UK, BBC London (af/as): World News. See S 1400.
- 1200 UK, BBC London (as): World News. See S 0000.
- 1205 Australia, Radio: Late Night Live. See M 1205.
- 1205 UK, BBC London (af/as): Outlook. See M 1205.
- 1210 Radio Australia via WRN1 (NAM): Asia Pacific.
- 1230 Radio Australia via WRN1 (NAM): The Law Report.
- 1245 UK, BBC London (af/as): Sports Roundup. See S 0320.

### Wednesdays

- 1200 Australia, Radio: RA News. See S 0000.
- 1200 Radio Australia via WRN1 (NAM): RA News.
- 1200 UK, BBC London (af/as): World News. See S 1400.
- 1205 Australia, Radio: Late Night Live. See M 1205.
- 1205 UK, BBC London (af/as): Outlook. See M 1205.
- 1210 Radio Australia via WRN1 (NAM): Sports News.
- 1215 Radio Australia via WRN1 (NAM): Pacific Focus.
- 1230 Radio Australia via WRN1 (NAM): The Religion Report.
- 1245 UK, BBC London (af/as): Sports Roundup. See S 0320.

### Thursdays

- 1200 Australia, Radio: RA News. See S 0000.
- 1200 Radio Australia via WRN1 (NAM): RA News.
- 1200 UK, BBC London (af/as): World News. See S 1400.
- 1205 Australia, Radio: Late Night Live. See M 1205.
- 1205 Radio Australia via WRN1 (NAM): Sports Focus.
- 1205 UK, BBC London (af/as): Outlook. See M 1205.
- 1230 Radio Australia via WRN1 (NAM): Media Report.
- 1245 UK, BBC London (af/as): Sports Roundup. See S 0320.

### Fridays

- 1200 Australia, Radio: RA News. See S 0000.
- 1200 Radio Australia via WRN1 (NAM): RA News.
- 1200 UK, BBC London (af/as): World News. See S 1400.
- 1205 Australia, Radio: Sound Quality. Tim Ritchie of National Radio presents

- inventions in contemporary music.
- 1205 UK, BBC London (af/as): Outlook. See M 1205.
- 1245 UK, BBC London (af/as): Sports Roundup. See S 0320.

### Saturdays

- 1200 Australia, Radio: RA News. See S 0000.
- 1200 Radio Australia via WRN1 (NAM): RA News.
- 1200 UK, BBC London (af/as): World News. See S 1400.
- 1205 Australia, Radio: The Week's End. See S 0430.
- 1205 Radio Australia via WRN1 (NAM): Asia Pacific.
- 1205 UK, BBC London (af): Football Extra. A review of the week's action and the upcoming weekend matches.
- 1205 UK, BBC London (as): Wright Round the World. See S 0330.
- 1215 UK, BBC London (af): Variable Feature. See M 1445.
- 1230 Australia, Radio: Pacific Review. See S 0530.
- 1230 Radio Australia via WRN1 (NAM): Oz Sounds.
- 1230 UK, BBC London (af): My Century. Moments from individuals' lives throughout the 20th century (5 or 30 mins).

## PROPAGATION FORECASTING

JACQUES D'AVIGNON, VE3VIA  
248 TOWERHILL ROAD  
PETERBOROUGH, ON K9H 7N1  
CANADA

DISTRIBUTOR ASAPS PROPAGATION SOFTWARE  
E-MAIL: MONITOR@RAC.CA

## FREQUENCIES

1300-1400	Anguilla, Caribbean Beacon	11775am							
1300-1400 vl	Australia, ABC/Alice Spgs	2310do							
1300-1400 vl	Australia, ABC/Katherine	2485do							
1300-1400 vl	Australia, ABC/Tent Creek	2325do							
1300-1400	Australia, Radio	6020pa	6080as	9580pa					
1300-1400 vl	Botswana, Radio	4820do	4830do	7255do					
1300-1320	Brazil, R Nacional Bras	15445am							
1300-1400 vl	Canada, CBC N Quebec Svc	9625do							
1300-1400	Canada, CFAX Toronto	6070do							
1300-1400	Canada, CFVP Calgary	6030do							
1300-1400	Canada, CHNX Halifax	6130do							
1300-1400	Canada, CKZN St John's	6160do							
1300-1400	Canada, CKZU Vancouver	6160do							
1300-1330	Canada, R Canada Intl	9640am	13650am	17715am					
1300-1355	China, China Radio Intl	11660as	11675pa	11715pa	11980as				
		15180as							
1300-1400	Ecuador, HCJB	12005am	15115am	21455va					
1300-1330	Egypt, Radio Cairo	17595as							
1300-1400 as/vl	Eq Guinea, R East Africa	15186af							
1300-1400	Germany, Sunrise Radio	5850eu							
1300-1330 s	Germany, Universal Life	15190as							
1300-1400 a	Germany, Good News World R	15190as							
1300-1400 vl	Ghana, Ghana BC Corp	4915do	6130do						
1300-1400	Guyana, CBC/Voice of	3290do	5950do						
1300-1400	Jordan, Radio	11690eu							
1300-1400	Kenya, Kenya BC Corp	4935do							
1300-1400 vl	Lesotho, Radio	4800do							
1300-1310	Liberia, LCN/R Liberia Int	5100do							
1300-1400	Malaysia, Radio	7295do							
1300-1400 vl	Malaysia, RTM Kota Kinabalu	5980do							
1300-1400 vl	N Manana Is, KHBI Saipan	9355as							
1300-1400 vl	Nambia, NBC	6060af	6175af						
1300-1325	Netherlands, Radio	6045eu	9855eu						
1300-1400 occsnal	New Zealand, R NZ Intl	6105pa							
1300-1400 vl	Nigeria, Radio/Ibadan	6050do							
1300-1400 vl	Nigeria, Radio/Kaduna	4770do							
1300-1400	Palau, KHBN/Voice of Hope	9965as	9985as	13840as					
1300-1400 vl	Papua New Guinea, NBC	4890do							
1300-1400	Romania, R Romania Intl	15335eu	17745na	17805eu					
1300-1400 as	S Africa, Channel Africa	11900af	17895af	21530af					
1300-1400	Singapore, R Singapore Int	6015as	6150as						
1300-1330	South Korea, R Korea Intl	9640as							
1300-1400	Sri Lanka, Sri Lanka BC	6005as	9730as	15425as					
1300-1400 as	Tanzania, Radio	5050af							
1300-1330	Turkey, Voice of	15295as	17815as						
1300-1400	Uganda, Radio	4976do							
1300-1400	UK, BBC World Service	5965na	5990as	6190af	6195va				
		9410eu	9515na	9590na	9740as				
		11750as	11760me	11940af	12095eu				
		15220am	15310as	15420af	15485eu				
		15565eu	15575as	17640eu	17705eu				
		17785as	17830af	17885af	21660af				
		9915eu	13645eu	17630eu	21550af				
1300-1400	UK, Merlin Network One	13815va							
1300-1400	USA, KAIJ Dallas TX	9615as							
1300-1400	USA, KNLS Anchor Point AK	7510am							
1300-1400	USA, KTVB Salt Lk City UT	9930as	11565pa						
1300-1400	USA, KWHR Naalehu HI	6160as	9645as	9760as	11705as				
1300-1400	USA, Voice of America	11715as	15425as						
		11875na	15745va						
1300-1400	USA, WEWN Birmingham AL	9400am							
1300-1400	USA, WGTG McCaysville GA	6040am	15105am						
1300-1400	USA, WHRI Noblesville IN	7490na	13595as						
1300-1400	USA, WJCR Upton KY	9955am							
1300-1315	USA, WRMI/R Miami Intl	7395am							
1300-1400	USA, WRNO New Orleans LA	9430am	9455am						
1300-1400 vl	USA, WSHB Cypress Crk SC	9475na	12160na	13845na	15685na				
1300-1400	USA, WWCR Nashville TN	5950na	11550as	11830na	11970na				
1300-1400	USA, WYFR Okeechobee FL	13695na							
1300-1400	Zambia, Christian Voice	6065af							
1300-1400	Zambia, Natl BC Corp	6165do	6265do						
1300-1400 vl	Zimbabwe, Zimbabwe BC	4828do	5012do						
1315-1325 mtwhfa	Bhutan, Bhutan BC Service	5030do							
1315-1400 as	USA, WRMI/R Miami Intl	9955am							
1325-1400	Germany, Voice of Hope	15715as							
1330-1400	Austria, R Austria Intl	6155eu	13730na						
1330-1359	Canada, R Canada Intl	6150as	9535as	9640na	13650na				
		17715na							
1330-1400	Finland, YLE/R Finland	15400na	17660na						
1330-1400	Guam, AWR/KSDA	11660as							
1330-1400	India, All India Radio	9545as	11620as	13710as					
1330-1400	Sweden, Radio	9425as	13740as	15240as					
1330-1400	UAE, Radio Dubai	13630eu	13675eu	15395eu	21605eu				
1330-1400	Uzbekistan, R Tashkent	5060as	5975as	6025as	9715as				
		11905as	15295as	17775as					
1330-1355	Vietnam, Voice of	5940eu	7270eu	7400eu	9840eu				
		12019eu							
1345-1400	Vatican State, Vatican R	13765au	15500au						

## SELECTED PROGRAMS

### Sundays

- 1300 Australia, Radio: RA News. See S 0000.
- 1300 RTE Dublin via WRN1 (NAM): This Week.
- 1300 UK, BBC London (af/as): Newshour. A comprehensive look at the major topics of the day, plus up-to-the-minute international and British news.
- 1305 Australia, Radio: Country Club (Part 2). ABC's program of contemporary and traditional country music with Richard Porteous (2nd Hour).
- 1328 Egypt, Radio Cairo: News Headlines.

### Mondays

- 1300 Australia, Radio: RA News. See S 0000.
- 1300 RTE Dublin via WRN1 (NAM): News at One.
- 1300 UK, BBC London (af/as): Newshour. See S 1300.
- 1310 Egypt, Radio Cairo: Arabic by Radio.
- 1315 Australia, Radio: The Planet (Part 1). Lucky Oceans plays richly varied music from around the world.
- 1328 Egypt, Radio Cairo: News Headlines.
- 1345 RTE Dublin via WRN1 (NAM): Liveline.

### Tuesdays

- 1300 Australia, Radio: RA News. See S 0000.
- 1300 RTE Dublin via WRN1 (NAM): News at One.
- 1300 UK, BBC London (af/as): Newshour. See S 1300.
- 1315 Australia, Radio: The Planet (Part 1). See M 1315.
- 1328 Egypt, Radio Cairo: News Headlines.
- 1345 RTE Dublin via WRN1 (NAM): Liveline.

### Wednesdays

- 1300 Australia, Radio: RA News. See S 0000.
- 1300 RTE Dublin via WRN1 (NAM): News at One.
- 1300 UK, BBC London (af/as): Newshour. See S 1300.
- 1315 Australia, Radio: The Planet (Part 1). See M 1315.
- 1328 Egypt, Radio Cairo: News Headlines.
- 1345 RTE Dublin via WRN1 (NAM): Liveline.

### Thursdays

- 1300 Australia, Radio: RA News. See S 0000.
- 1300 RTE Dublin via WRN1 (NAM): News at One.
- 1300 UK, BBC London (af/as): Newshour. See S 1300.
- 1315 Australia, Radio: The Planet (Part 1). See M 1315.
- 1328 Egypt, Radio Cairo: News Headlines.
- 1345 RTE Dublin via WRN1 (NAM): Liveline.

### Fridays

- 1300 Australia, Radio: RA News. See S 0000.
- 1300 RTE Dublin via WRN1 (NAM): News at One.

- 1300 UK, BBC London (af/as): Newshour. See S 1300.
- 1315 Australia, Radio: The Planet (Part 1). See M 1315.
- 1328 Egypt, Radio Cairo: News Headlines.
- 1345 RTE Dublin via WRN1 (NAM): Liveline.

### Saturdays

- 1300 Australia, Radio: Radio National News. See F 1400.
- 1300 RTE Dublin via WRN1 (NAM): Saturday View.
- 1300 UK, BBC London (af/as): Newshour. See S 1300.
- 1305 Australia, Radio: Science Show. See T 0110.
- 1328 Egypt, Radio Cairo: News Headlines.

### MT MONITORING TEAM

Gayle Van Horn  
Frequency Manager  
gayle@grove.net

Jim Frimmel  
Program Manager  
frimmel@star-telegram.com

Jacques d'Avignon  
Propagation Forecasts  
Ontario, Canada  
monitor@rac.ca

Dave Datko, California  
Mark Fine, VA

### THANK YOU...

### ADDITIONAL CONTRIBUTORS TO THIS MONTH'S SHORTWAVE GUIDE:

John Babbis, Silver Spring, MD; Bob Fraser, Cohasset, MA; David Franz, McCaysville, GA; *Hard Core DX*; Clyde W. Harmon, Anniston, AL; Glenn Hauser, Enid, OK/*World of Radio & DX Report*; Mike Osborn/KNLS; BBCM; AI Quaglieri/*NASWA Journal*; Giovanni Serra/*The Four Winds*; Usenet Newsgroups.



# GRUNDIG

# Gives you the World



## Grundig leads shortwave radio into the new Millennium!

When radio was introduced, back in the 1920's— to pluck voices and music out of thin air — people thought it was magic. With Grundig, it still is! No other manufacturer rivals Grundig for *“that European sound.”* Voices have an *“in-the-room”* quality and clarity — even from half a world away.

German-engineered quality... German-engineered sound... when people think of shortwave, they think of Grundig. Grundig has specialized in shortwave since the late 1950's, and in North America, shortwave radios are all we sell.

Critics reviews of Grundig models include *Best of Category... Superior Performance... Ergonomically Better... Superb Sound Quality... An Excellent Choice*

## We listen, too.

We're very good at listening — to our customers. Our engineers design each model so it's easy, intuitive, and convenient to use. Critics call this *“great ergonomics!”* And Grundig models always deliver top performance for the price. Critics call this *“bang for the buck.”*



# GRUNDIG

## The Latest in Technology

### Rated Best in Its Class.

Grundig's Yacht Boy 400PE has received rave reviews from the shortwave press for combining a wealth of sophisticated features in a sleek titanium-look package that doesn't cost a fortune. It incorporates features found on stationary shortwave systems that cost thousands, such as outstanding audio quality, precise 1 kHz increment tuning, up/down slewing, frequency scanning, signal strength indication, and single-sideband signal demodulation.

But the advantage mentioned most often in the reviews is its ease of use for the novice listener. In moments you can listen to foreign broadcasts beamed to North America.

Soon, you will be scanning the airwaves to tune in exotic music programs and sports events from faraway locales. The YB-400PE even picks up shortwave amateur (ham radio) broadcasts and shortwave aviation/military frequencies (cockpit-to-tower communications). The possibilities for family fun, education, and enjoyment are boundless.

For travel or home use, Grundig adds a dual-time travel clock with snooze and sleep timer. The FM band is stereophonic with your headphones. The lighted LCD panel is easy to read in the

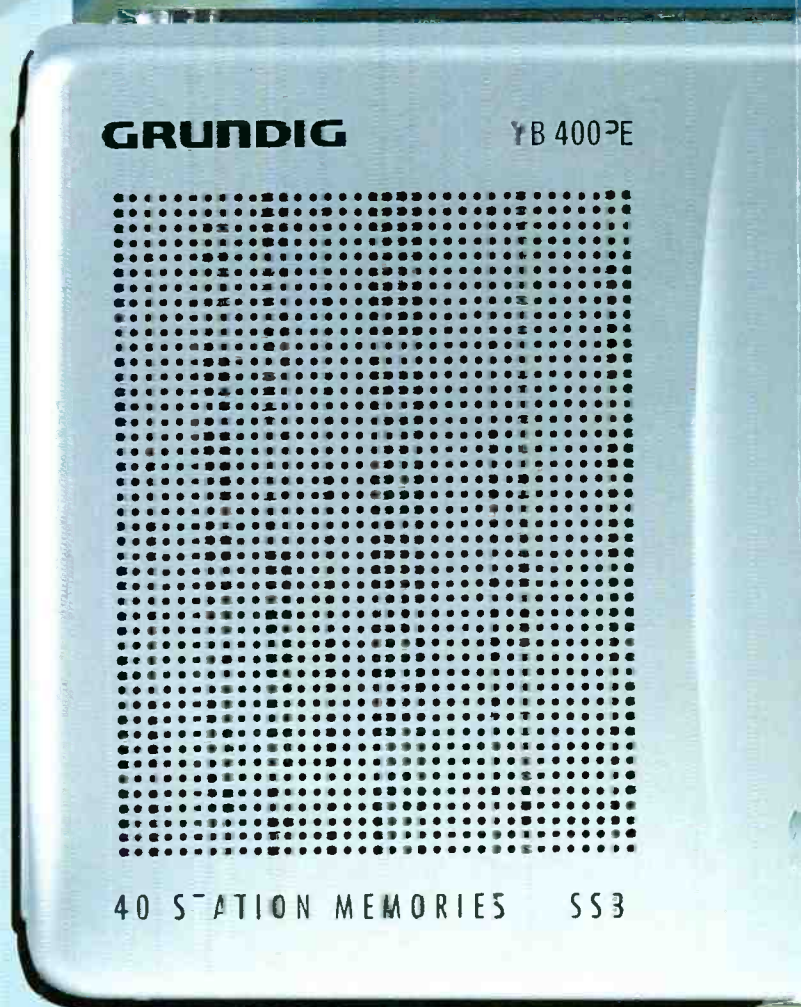



# Yacht Boy 400PE

## The Best in Value!

dark. Comes with a form-fitting pouch, integral telescoping antenna and advanced external antenna on a compact reel, carry-strap, ac-adaptor, ear-phones and complete instructions.

### Made by Germany's Grundig.

World leader in shortwave radios, the 400PE measures just 7-3/4"L x 4-1/4"H x 1-1/4"W; weighs only 20 oz. It slips easily into your carry-on for travel and fits on a nightstand, office credenza, or yacht cabin console. One-year warranty.

### Grundig's Yacht Boy 400PE Named Editor's Choice.

*Passport To World Band Radio* is regarded as the leading authority of the shortwave industry. Here's what their testing expert wrote about the Grundig Yacht Boy 400PE:

*"Best performance for price size category, and among the choicest portables of any size, at any price."*

*"The 400's FM performance is right up there with the very best among world band radios."*

Please call our shortwave hotline and talk to the experts: 800-872-2228.



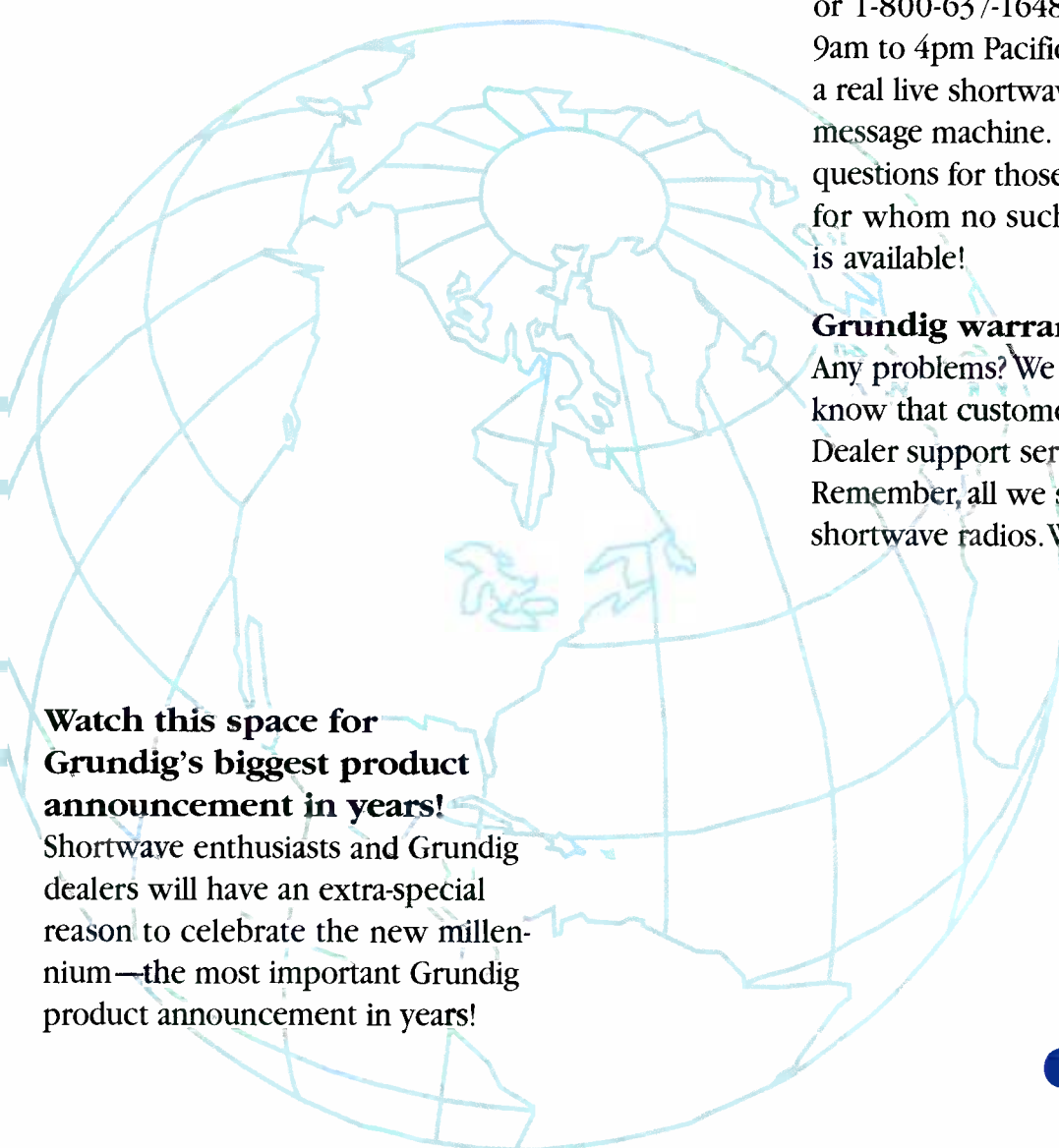

**Grundig sets the standard for customer service.**

Grundig supports the industry's only Toll-free Shortwave Hotline. Consumers and dealers can call 1-800-872-2228 in the United States or 1-800-637-1648 in Canada weekdays from 9am to 4pm Pacific Time. You can speak with a real live shortwave expert, not an automatic message machine. Grundig even answers questions for those who own other brands, for whom no such toll-free hotline service is available!

**Grundig warranty service is the best.**

Any problems? We fix them fast. Dealers know that customers will be taken care of! Dealer support service is first-rate, too. Remember, all we sell in North America are shortwave radios. We specialize! We do it best!

**Watch this space for Grundig's biggest product announcement in years!**

Shortwave enthusiasts and Grundig dealers will have an extra-special reason to celebrate the new millennium—the most important Grundig product announcement in years!

**GRUNDIG**  
*made for you*



## FREQUENCIES

1400-1500	Anguilla, Caribbean Beacon	11775am				1400-1455 as	S Africa, Channel Africa	11900af	17895af	21530af	
1400-1500 vl	Australia, ABC/Alice Spgs	2310do				1400-1500	Singapore, RTE Radio	15360as			
1400-1500 vl	Australia, ABC/Katherine	2485do				1400-1500	Singapore, RCorp Singapore	6150do			
1400-1500 vl	Australia, ABC/Tent Creek	2325do				1400-1500	Sri Lanka, Sri Lanka BC	6005as	9730as	15425as	
1400-1500	Australia, Radio	5995pa	6020pa	6080as	9580pa	1400-1500	Switzerland, Swiss R Intl	12010as	15185as		
1400-1500 vl	Botswana, Radio	4820do	4830do	7255do		1400-1500 as	Tanzania, Radio	5050af			
1400-1500 vl	Canada, CBC N Quebec Svc	9625do				1400-1430	Thailand, Radio	9530as	9655as	11905as	
1400-1500	Canada, CFRX Toronto	6070do				1400-1500	Uganda, Radio	4976do			
1400-1500	Canada, CFVP Calgary	6030do				1400-1500	UK, BBC World Service	5990as	6190af	6195as	9410eu
1400-1500	Canada, CHNX Halifax	6130do						9515na	9590na	9740as	11750as
1400-1500	Canada, CKZN St John's	6160do						11940af	12095eu	15220na	15310as
1400-1500	Canada, CKZU Vancouver	6160do						15485eu	15565eu	15575as	17640eu
1400-1459 mtwhfs	Canada, R Canada Intl	9640am	13650am	17715am				17705eu	17830af	17840am	21470af
1400-1456	China, China Radio Intl	7405na	9535as	9700as	11825as			21660af			
		15125af				1400-1500	UK, Merlin Network One	9915eu	13680eu	17630eu	21550af
1400-1500	Costa Rica, RF Peace Intl	21460am				1400-1500	USA, KAJ Dallas TX	13815na			
1400-1430	Czech Rep, R Prague Intl	21745va				1400-1500	USA, KJES Mesquite NM	11715na			
1400-1500	Ecuador, HCJB	12005am	15115am	21455va		1400-1500	USA, KTBN Salt Lk City UT	7510am			
1400-1500 as/vl	Eqt Guinea, R East Africa	15186af				1400-1500	USA, KWHR Naalehu HI	9930as	11565pa		
1400-1457	France, Radio France Intl	11910as	12030as	17560af		1400-1500	USA, Voice of America	6110as	7125as	7215as	9645as
1400-1500	Germany, RTE Radio	15625eu						9760as	11705as	15205me	15395as
1400-1500	Germany, Sunnse Radio	5850eu						15425as			
1400-1500	Germany, Voice of Hope	15715as				1400-1500	USA, WEWN Birmingham AL	11875na	15745va		
1400-1500 vl	Ghana, Ghana BC Corp	4915do	6130do			1400-1500	USA, WGTG McCaysville GA	9400am			
1400-1500	Guyana, GBC/Voice of	3290do	5950do			1400-1500	USA, WHRI Noblesville IN	6040am	15105am		
1400-1500	India, All India Radio	9545as	11620as	13710as		1400-1500	USA, WJCR Upton KY	7490na	13595as		
1400-1430	Israel, Kol Israel	15650va	17535va			1400-1500 irreg	USA, WMLK Bethel PA	9465am			
1400-1500	Japan, Radio/NHK	9505na	11730as	11880af		1400-1500 s	USA, WRMI/R Miami Intl	9955ca			
1400-1500	Jordan, Radio	11690eu				1400-1500	USA, WRNO New Orleans LA	7395am			
1400-1500	Kenya, Kenya BC Corp	4935do				1400-1500	USA, WYCR Nashville TN	9475na	12160na	13845na	15685na
1400-1500 vl	Lesotho, Radio	4800do				1400-1500	USA, WYFR Okeechobee FL	5950na	11550as	11830na	17760na
1400-1500	Malaysia, Radio	7295do				1400-1405	Vatican State, Vatican R	13765au	15500au		
1400-1500	Malaysia, RTM Sarawak	7160do				1400-1500	Zambia, Christian Voice	6065af			
1400-1500 vl	Malaysia, RTM KotaKinabalu	5980do				1400-1500	Zambia, Natl BC Corp	6165do	6265do		
1400-1430	Mexico, Radio Mexico Intl	5985na	9705na			1400-1500 vl	Zimbabwe, Zimbabwe BC	4828do	5012do		
1400-1500 vl	Namibia, NBC	6060af	6175af			1410-1420	Greece, Voice of	7450eu	9425na		
1400-1500 occsnal	New Zealand, R NZ Intl	6105pa				1415-1420	Nepal, Radio	3230as	5005as		
1400-1500 vl	Nigeria, Radio/Ibadan	6050do				1430-1500	Australia, Radio	9500as	11660as		
1400-1500 vl	Nigeria, Radio/Kaduna	4770do				1430-1459	Canada, R Canada Intl	9555va	11915va	15325va	
1400-1414	Pakistan, Radio	11570af	15170af	15465af		1430-1500 vl	China, China Radio Intl	6995as	9880as		
1400-1500	Palau, KHBV/Voice of Hope	9965as	9965as	9985as		1430-1500	Guam, AWR/KSDA	9835as	11980as		
1400-1500 vl	Papua New Guinea, NBC	4890do				1430-1500	Myanmar, Radio	5990do			
1400-1500	Philippines, FEBC/R Intl	11995as				1430-1500	Netherlands, Radio	12070as	12090as	15585as	
1400-1500	Russia, Voice of Russia WS	9475as	9480eu	9710eu	9800as	1430-1500	S Africa, RTE Radio	21745af			
		11500as	15550as			1430-1500	Sweden, Radio	13740na	15240na	17870na	21810na
						1430-1500 as	UK, BBC World Service	5990as	6195as	9740as	

## SELECTED PROGRAMS

### Sundays

- 1400 Australia, Radio: RA News. See S 0000.
- 1400 Radio Prague via WRN1 (NAM): News.
- 1400 UK, BBC London (af): World News. Broadcast on the hour of 5, 10, or 15 minutes in length.
- 1400 UK, BBC London (as): News Summary. One minute news update.
- 1405 Australia, Radio: The Planet (Part 2). See M 1315.
- 1405 Radio Prague via WRN1 (NAM): The Week in Politics.
- 1405 UK, BBC London (af/as): Newstalk. Robin Lustig presents topical conversation on the main issues of the week as listeners air their views.
- 1412 Radio Prague via WRN1 (NAM): From the Weeklies.
- 1418 Radio Prague via WRN1 (NAM): Media Check.
- 1430 Australia, Radio: Pacific Review. See S 0530.
- 1430 London Radio Service via WRN1 (NAM): London Radio.
- 1430 London Radio Service via WRN1 (NAM): The Way Ahead.
- 1445 London Radio Service via WRN1 (NAM): New Horizons.

### Mondays

- 1400 Australia, Radio: RA News. See S 0000.
- 1400 UK, BBC London (af/as): World News. See S 1400.
- 1405 Australia, Radio: The Planet (Part 2). See M 1315.
- 1405 UK, BBC London (af/as): Health Matters. Keeps track of new developments in the world of medical science, as well as ways of keeping fit.
- 1430 UK, BBC London (af). Science Extra. Either Soundbyte (viral games and the Internet) or Seeing Stars (a look at the night skies).
- 1430 UK, BBC London (as): The Farming World (EAs). See M 0135.
- 1430 UK, BBC London (as): Variable Feature. See S 1530.
- 1445 UK, BBC London (af/as): Variable Feature. Special features and new series.

### Tuesdays

- 1400 Australia, Radio: RA News. See S 0000.
- 1400 Radio Prague via WRN1 (NAM): News.

- 1400 UK, BBC London (af/as): World News. See S 1400.
- 1405 Australia, Radio: The Planet (Part 2). See M 1315.
- 1405 UK, BBC London (af): Discovery. In-depth look at scientific research.
- 1405 UK, BBC London (as): Discovery. See T 0005.
- 1406 Radio Prague via WRN1 (NAM): Current Affairs.
- 1418 Radio Prague via WRN1 (NAM): Talking Point.
- 1430 Channel Africa via WRN1 (NAM): News.
- 1430 UK, BBC London (af): Variable Feature. See M 1445.
- 1430 UK, BBC London (as): Variable Feature (EAs). See S 1530.
- 1430 UK, BBC London (as): Variable Music Feature. See T 0530.
- 1435 Channel Africa via WRN1 (NAM): Dateline Africa.

### Wednesdays

- 1400 Australia, Radio: RA News. See S 0000.
- 1400 UK, BBC London (af/as): World News. See S 1400.
- 1405 Australia, Radio: The Planet (Part 2). See M 1315.
- 1405 UK, BBC London (af/as): One Planet. Charles Haviland and Richard Black host this new program about development and the environment.
- 1430 Channel Africa via WRN1 (NAM): News.
- 1430 UK, BBC London (af): Variable Music Feature. See M 0230.
- 1430 UK, BBC London (as): Sports International. See W 0030.
- 1430 UK, BBC London (as): Variable Feature (EAs). See S 1530.
- 1435 Channel Africa via WRN1 (NAM): Dateline Africa.
- 1445 UK, BBC London (as): World Business Report (EAs). See M 1645.

### Thursdays

- 1400 Australia, Radio: RA News. See S 0000.
- 1400 Radio Prague via WRN1 (NAM): News.
- 1400 UK, BBC London (af/as): World News. See S 1400.
- 1405 Australia, Radio: The Planet (Part 2). See M 1315.
- 1405 UK, BBC London (af/as): The Works. Alun Lews looks at the impact of tomorrow's technology.
- 1406 Radio Prague via WRN1 (NAM): Current Affairs.
- 1416 Radio Prague via WRN1 (NAM): Economic Report.
- 1425 Radio Prague via WRN1 (NAM): Music.

- 1430 Channel Africa via WRN1 (NAM): News.
- 1430 UK, BBC London (af): Variable Feature. See M 1445.
- 1430 UK, BBC London (as): Assignment. See H 0030.
- 1435 Channel Africa via WRN1 (NAM): Dateline Africa.

### Fridays

- 1400 Australia, Radio: Radio National News. News from the Australian Broadcasting Network (ABC).
- 1400 Radio Prague via WRN1 (NAM): News.
- 1400 UK, BBC London (af/as): World News. See S 1400.
- 1405 Australia, Radio: The Planet (Part 2). See M 1315.
- 1405 UK, BBC London (af/as): Science in Action. The latest in science and technology.
- 1406 Radio Prague via WRN1 (NAM): Current Affairs.
- 1418 Radio Prague via WRN1 (NAM): Postbag.
- 1425 Radio Prague via WRN1 (NAM): Music.
- 1430 Channel Africa via WRN1 (NAM): News.
- 1430 UK, BBC London (af): Record News. Focus on the most interesting new releases of classical recordings.
- 1430 UK, BBC London (as): Focus on Faith. See F 0030.
- 1435 Channel Africa via WRN1 (NAM): Dateline Africa.
- 1445 UK, BBC London (af): The Farming World. Reports on new developments from around the world.

### Saturdays

- 1400 Australia, Radio: Radio National News. See F 1400.
- 1400 Radio Prague via WRN1 (NAM): News.
- 1430 UK, BBC London (af/as): World News. See S 1400.
- 1430 UK, BBC London (as): World News. See S 0000.
- 1435 Australia, Radio: New Dimensions. No program - no information available.
- 1435 UK, BBC London (af/as): Sportsworld. The weekly sports magazine.
- 1436 Radio Prague via WRN1 (NAM): Let's Go.
- 1430 Channel Africa via WRN1 (NAM): News.
- 1435 Channel Africa via WRN1 (NAM): Network Africa.

FREQUENCIES

Table with columns for frequency ranges (e.g., 1500-1600) and various international radio stations (e.g., Australia, BBC, Voice of America) and their frequencies.

SELECTED PROGRAMS

Sundays

- 1500 Australia, Radio: RA News. See S 0000.
1500 UK, BBC London (af/as): World News. See S 1400.
1500 UK, BBC London (as): World News. See S 0000.
1500 Voice of America via WRN1 (NAM): Communications World ABC.
1501 UK, BBC London (as): Play of the Week (SAs). A different radio drama program each week (alternative programming for South Asia).
1505 Australia, Radio: Encounter. This highly acclaimed Radio National series explores the connections between religion and life.
1505 UK, BBC London (af/as): From Our Own Correspondent. BBC correspondents comment on the background to the news.
1525 World Radio Network via WRN1 (NAM): Network Plus.
1530 UK, BBC London (af): The Learning Zone. For people who want to learn more about subjects such as science, health, the world and work and literature while practicing English listening skills.
1530 UK, BBC London (as): Variable Feature. Special features and new series.
1555 Australia, Radio: On This Day. Anniversaries worth remembering.

Mondays

- 1500 Australia, Radio: RA News. See S 0000.
1500 UK, BBC London (as): East Asia Today (EAs). News, analysis, press reviews and reports from BBC correspondents.
1500 UK, BBC London (as): World News. See S 0000.
1505 Australia, Radio: Asia Pacific. See M 1110.
1505 UK, BBC London (af): Focus on Africa. Up-to-the-minute reports on the day's events from all over the continent.
1505 UK, BBC London (as): Sports Roundup. See S 0405.
1515 UK, BBC London (as): Variable Feature. See S 1530.
1530 Australia, Radio: The Health Report. See M 0030.
1530 UK, BBC London (af): The Learning Zone. See S 1530.
1530 UK, BBC London (as): Meridian Feature. See M 0430.

Tuesdays

- 1500 Australia, Radio: RA News. See S 0000.
1500 UK, BBC London (af): World News. See S 1400.
1500 UK, BBC London (as): East Asia Today (EAs). See M 1500.
1500 UK, BBC London (as): World News. See S 0000.
1505 Australia, Radio: Asia Pacific. See M 1110.
1505 UK, BBC London (af): Focus on Africa. See M 1505.
1505 UK, BBC London (as): Sports Roundup. See S 0405.
1515 UK, BBC London (as): Variable Feature. See S 1530.
1530 Australia, Radio: The Law Report. See T 0030.
1530 UK, BBC London (af): The Learning Zone. See S 1530.
1530 UK, BBC London (as): Insight (EAs). See T 0105.
1555 UK, BBC London (as): Off the Shelf (EAs). See M 0145.

Wednesdays

- 1500 Australia, Radio: RA News. See S 0000.
1500 UK, BBC London (af): World News. See S 1400.
1500 UK, BBC London (as): East Asia Today (EAs). See M 1500.
1500 UK, BBC London (as): World News. See S 0000.
1505 Australia, Radio: Asia Pacific. See M 1110.
1505 UK, BBC London (af): Focus on Africa. See M 1505.
1505 UK, BBC London (as): Sports Roundup. See S 0405.
1515 UK, BBC London (as): Science Extra. Either Soundbyte (virtual games and the Internet) or Seeing Stars (a look at the night skies).
1530 Australia, Radio: The Religion Report. See W 0030.
1530 UK, BBC London (af): The Learning Zone. See S 1530.
1530 UK, BBC London (as): Insight (EAs). See T 0105.
1530 UK, BBC London (as): Meridian Live. See W 0430.
1545 UK, BBC London (as): Off the Shelf (EAs). See M 0145.

Thursdays

- 1500 Australia, Radio: RA News. See S 0000.
1500 UK, BBC London (af): World News. See S 1400.

- 1500 UK, BBC London (as): East Asia Today (EAs). See M 1500.
1500 UK, BBC London (as): World News. See S 0000.
1505 Australia, Radio: Asia Pacific. See M 1110.
1505 UK, BBC London (af): Focus on Africa. See M 1505.
1505 UK, BBC London (as): Sports Roundup. See S 0405.
1515 UK, BBC London (as): From Our Own Correspondent. See S 0005.
1530 Australia, Radio: Money, Markets, and the Economy. See S 0005.
1530 UK, BBC London (af): The Learning Zone. See S 1530.
1530 UK, BBC London (as): Insight (EAs). See T 0105.
1530 UK, BBC London (as): Meridian Books. See H 0430.
1545 UK, BBC London (as): Off the Shelf (EAs). See M 0145.

Fridays

- 1500 Australia, Radio: RA News. See S 0000.
1500 UK, BBC London (af): World News. See S 1400.
1500 UK, BBC London (as): East Asia Today (EAs). See M 1500.
1500 UK, BBC London (as): World News. See S 0000.
1505 Australia, Radio: Asia Pacific. See M 1110.
1505 UK, BBC London (af): Focus on Africa. See M 1505.
1505 UK, BBC London (as): Football Extra. A review of the week's action and the upcoming weekend matches.
1515 UK, BBC London (as): Variable Feature. See S 1530.
1530 Australia, Radio: The Sports Factor. See F 0030.
1530 UK, BBC London (af): The Learning Zone. See S 1530.
1530 UK, BBC London (as): Insight (EAs). See T 0105.
1530 UK, BBC London (as): Music Review. See F 0430.
1555 UK, BBC London (as): Off the Shelf (EAs). See M 0145.

Saturdays

- 1500 Australia, Radio: Radio National News. See F 1400.
1500 UK, BBC London (af/as): World News. See S 1400.
1505 Australia, Radio: Melisma (Part 1). Musical revelations (1st hour).
1505 UK, BBC London (af/as): Sportsworld. See A 1405.



## FREQUENCIES

1600-1700	Algeria, R Algiers Intl	6160af	11715af	15160me	1600-1700	Swaziland, Trans World R	9500af		
1600-1700	Anguilla, Caribbean Beacon	11775am			1600-1615	Switzerland, Swiss R Intl	12010as	15185as	
1600-1700 vl	Australia, ABC/Alice Spgs	2310do			1600-1700	Tanzania, Radio	5050af		
1600-1700 vl	Australia, ABC/Katherine	2485do			1600-1645	UAE, Radio Dubai	13630eu	13675eu	15395eu
1600-1700 vl	Australia, ABC/Tent Creek	2325do			1600-1700	Uganda, Radio	4976do		
1600-1700	Australia, Radio	5995pa	9500as	9580pa	1600-1700	UK, BBC World Service	3915as	5975as	5990as
		11660as		9660pa			6195va	7160as	9410eu
1600-1700 vl	Botswana, Radio	4820do	4830do	7255do			9740as	11750as	11940af
1600-1700 vl	Canada, CBC N Quebec Svc	9625do			1600-1700	UK, Merlin Network One	16185eu	21550af	
1600-1700	Canada, CFRX Toronto	6070do			1600-1700	USA, KAIJ Dallas TX	13815va		
1600-1700	Canada, CFVP Calgary	6030do			1600-1700	USA, KTNB Salt Lk City UT	15590am		
1600-1700	Canada, CHNX Halifax	6130do			1600-1700	USA, KWHR Naalehu HI	9930as		
1600-1700	Canada, CKZN St John's	6160do			1600-1700	USA, Voice of America	6035af	6110as	7125as
1600-1700	Canada, CKZU Vancouver	6160do					9575me	9645as	9760as
1600-1659 s	Canada, R Canada Intl	9640am	13650am	17715am			12040af	13600af	13710af
1600-1656	China, China Radio Intl	9565af					15225af	15240af	15395as
1600-1700	Costa Rica, RF Peace Intl	15050am	21460am				15445af	17895af	15410af
1600-1700	Ethiopia, Radio	7165af	9560af				11875na	13615na	15745va
1600-1654	France, Radio France Intl	11615af	11700af	11995af	1600-1700	USA, WEWN Birmingham AL	11875na		
		15210af	15530af		1600-1700	USA, WGTG McCaysville GA	9400am		
		6170as	7120af	7225as	1600-1700	USA, WHRI Noblesville IN	13760am	15105am	
1600-1650	Germany, Deutsche Welle	9585as	9735af	11810af	1600-1700	USA, WJCR Upton KY	7490na	13595as	
		15145af	17800af	13790as	1600-1700 irreg	USA, WMLK Bethel PA	9465am		
		5850eu			1600-1700	USA, WRNO New Orleans LA	15420am		
1600-1630 s	Germany, Universal Life	11840af			1600-1700 vl	USA, WSHB Cypress Crk SC	18910af		
1600-1700 a	Germany, Good News World R	11840vz			1600-1700	USA, WWCR Nashville TN	9475na	12160na	13845na
1600-1700	Germany, Overcomer Ministr	6010eu	13810me		1600-1700	USA, WYFR Okeechobee FL	11830na	15215na	15695eu
1600-1700 vl	Ghana, Ghana BC Corp	4915do	6130do				17760ca	21525af	15685na
1600-1700	Guam, AWR/KSDA	9355as	11625as		1600-1610	Vatican State, Vatican F	11640va	13760va	
1600-1630	Guam, TWR/KTWR	12015as			1600-1625	Vietnam, Voice of	5940eu	7270eu	7400eu
1600-1700	Guyana, GBC/Voice of	3290do	5950do				12019eu		9840af
1600-1630	Iran, VOIRI	9780as	11775as	13605as	1600-1700	Zambia, Christian Voice	3330af	4965af	
1600-1630	Jordan, Radio	11690eu			1600-1700	Zambia, Nati BC Corp	6165do	6265do	
1600-1700	Kenya, Kenya BC Corp	4935do			1600-1630 vl	Zimbabwe, Zimbabwe BC	4828do	5012do	
1600-1700	Lebanon, Voice of Hope	9960me			1615-1700 as	UK, BBC World Service	9515na	11860af	
1600-1700 vl	Lesotho, Radio	4800do			1615-1630	Vatican State, Vatican R	4005eu	5883eu	7250eu
1600-1700	Malaysia, Radio	7295do					15595eu		9645eu
1600-1700 vl	Namibia, NBC	6060af	6175af		1630-1656	Belgium, R Vlaanderen Int	5910eu	12080eu	13650eu
1600-1625	Netherlands, Radio	12070as	12090as	15585as	1630-1700	Canada, R Canada Intl	6140as	7150as	
1600-1650 occsnal	New Zealand, R NZ Intl	6105pa			1630-1700	Canada, R Canada Intl	6140as	7150as	
1600-1700 vl	Nigeria, Radio/Ibadan	6050do			1630-1700 s	Canada, R Canada Intl	9640na	13650na	17715na
1600-1700 vl	Nigeria, Radio/Kaduna	4770do			1630-1700	Egypt, Radio Cairo	15255af		
1600-1700	Nigeria, Voice of	7255af	15120va		1630-1700 mtwhf	Eq Guinea, Radio Afrca	7190af	15186af	
1600-1630	Pakistan, Radio	11570me	15170af	15325eu	1630-1700	Georgia, Georgian Radio	6180me		
		17720af		15465me	1630-1700 s	Seychelles, FEBA Radio	11665as		
1600-1700	Palau, KHBN/Voice of Hope	9955as	9965as		1630-1700	Slovakia, R Slovakia Intl	5915eu	6055eu	7345eu
1600-1700 vl	Papua New Guinea, NBC	4890do			1630-1700 vl	Zimbabwe, Zimbabwe BC	3306do	4828do	
1600-1700	Russia, Voice of Russia WS	9830me	12065me		1645-1700	Tajikistan, Radio	7245as		
1600-1630	S Africa, Channel Africa	6000af			1650-1700 mtwhf	New Zealand, R NZ Intl	11675pa		
1600-1700	South Korea, R Korea Intl	5975as	9515va	9870as					

## SELECTED PROGRAMS

### Sundays

1600	Australia, Radio: RA News. See S 0000.
1600	Radio France Intl via WRN1 (NAM): News.
1600	UK, BBC London (af/as): World News. See S 1400.
1605	Australia, Radio: The National Interest. Terry Lane takes an incisive look at the week's major events.
1615	UK, BBC London (af): Concert Hall. Classical music concerts.
1615	UK, BBC London (as): Short Story. Fifteen-minute dramas written by listeners from around the world.
1621	Radio France Intl via WRN1 (NAM): Asia File.
1630	UK, BBC London (as): Global Business. See S 0130.
1632	Radio France Intl via WRN1 (NAM): News Headlines.
1637	Radio France Intl via WRN1 (NAM): Club 9516.

### Mondays

1600	Australia, Radio: RA News. See S 0000.
1600	Radio France Intl via WRN1 (NAM): News.
1600	UK, BBC London (af/as): World News. See S 1400.
1605	Australia, Radio: Music Deli. Paul Petran presents music from a variety of cultures.
1615	UK, BBC London (af): Fast Track. The latest African sports news and action.
1615	UK, BBC London (as): Multitrack Hit-List. The UK Top 20
1645	UK, BBC London (af): Insight. An examination of a topical aspect of the international scene.
1645	UK, BBC London (as): World Business Report. Latest news from the markets in the Far East, Europe and the USA.

### Tuesdays

1600	Australia, Radio: RA News. See S 0000.
1600	Radio France Intl via WRN1 (NAM): News.
1600	UK, BBC London (af/as): World News. See S 1400.
1605	Australia, Radio: The Comfort Zone. Architecture and design.

1615	gardens, food and travel with Alan Saunders.
1615	UK, BBC London (af): African Perspective. A considered view of life and issues facing the African continent.
1615	UK, BBC London (as): Megamix. A youth magazine series which covers new trends, entertainment, sport and other issues.
1645	UK, BBC London (af): Insight. See M 1645.
1645	UK, BBC London (as): World Business Report. See M 1645.

### Wednesdays

1600	Australia, Radio: RA News. See S 0000.
1600	Radio France Intl via WRN1 (NAM): News.
1600	UK, BBC London (af/as): World News. See S 1400.
1605	Australia, Radio: Women Out Loud!. A weekly radio program documenting, exploring and challenging the conditions of women's lives.
1615	UK, BBC London (af): Talkabout Africa. Telephone conversations with BBC correspondents on late-breaking African events.
1615	UK, BBC London (as): Multitrack X-Press. New pop records, interviews, news and competitions.
1645	UK, BBC London (af): Insight. See M 1645.
1645	UK, BBC London (as): World Business Report. See M 1645.

### Thursdays

1600	Australia, Radio: RA News. See S 0000.
1600	Radio France Intl via WRN1 (NAM): News.
1600	UK, BBC London (af/as): World News. See S 1400.
1605	Australia, Radio: Verbatim. New program--no information available.
1615	UK, BBC London (af): Art Beat. See S 0430.
1615	UK, BBC London (as): Variable Feature. See S 1530.
1626	Radio France Intl via WRN1 (NAM): Review of the French Newspapers.
1630	Australia, Radio: Earshot. See H 1605.
1630	Radio France Intl via WRN1 (NAM): News Headlines.
1631	Radio France Intl via WRN1 (NAM): Sports Magazine.

1633	Radio France Intl via WRN1 (NAM): Reach Out.
1639	Radio France Intl via WRN1 (NAM): News Headlines.
1642	Radio France Intl via WRN1 (NAM): Echoes from Africa.
1645	UK, BBC London (af): Insight. See M 1645.
1645	UK, BBC London (as): World Business Report. See M 1645.
1648	Radio France Intl via WRN1 (NAM): Discovery.

### Fridays

1600	Australia, Radio: RA News. See S 0000.
1600	Radio France Intl via WRN1 (NAM): News.
1600	UK, BBC London (af/as): World News. See S 1400.
1605	Australia, Radio: Away. See M 0110.
1615	UK, BBC London (af): Fast Track. See M 1615.
1615	UK, BBC London (as): Multitrack Alternative. See F 0630.
1626	Radio France Intl via WRN1 (NAM): Review of the French Newspapers.
1630	Radio France Intl via WRN1 (NAM): News Headlines.
1631	Radio France Intl via WRN1 (NAM): Weekend.
1645	UK, BBC London (af): Insight. See M 1645.
1645	UK, BBC London (as): Britain Today. News about Britain.

### Saturdays

1600	Australia, Radio: RA News. See S 0000.
1600	Radio France Intl via WRN1 (NAM): News.
1600	UK, BBC London (af/as): World News. See S 1400.
1605	Australia, Radio: Melisma (Part 2). Musical revelations (2nd hour).
1605	UK, BBC London (af/as): Sportsworld. See A 1405.
1623	Radio France Intl via WRN1 (NAM): Focus on France.
1628	Radio France Intl via WRN1 (NAM): Review of the French Newspapers.
1631	Radio France Intl via WRN1 (NAM): News Headlines.
1632	Radio France Intl via WRN1 (NAM): Spotlight on Africa.
1645	Radio France Intl via WRN1 (NAM): News Update.
1647	Radio France Intl via WRN1 (NAM): French Lesson.

FREQUENCIES

Table with columns for frequency ranges (e.g., 1700-1800, 1700-1730), station names (e.g., Afghanistan, VO Shari'ah), and call signs (e.g., 7075do, 11775am, 2310do). The table lists various international radio stations and their operating frequencies across multiple columns.



FREQUENCIES

Table with columns for frequency, time, and station names. Includes entries for various countries like Anguilla, Australia, Botswana, Brazil, Bulgaria, Canada, China, Costa Rica, Ecuador, Germany, Greece, Guatemala, Guyana, Hungary, India, Israel, Italy, Kenya, Kuwait, Lebanon, Lesotho, Liberia, Malaysia, Malta, New Zealand, Nigeria, North Korea, Papua New Guinea, Russia, Solomon Islands, South Korea, Swaziland, Switzerland, Tanzania, Thailand, Turkey, Uganda, UK, USA, Vanuatu, Vietnam, Zambia, Albania, Belarus, Georgia, Iran, Poland, Italy, Vatican, New Zealand, S Africa, Algeria, Anguilla, Australia, Botswana, Canada, China, Costa Rica, Ecuador, Finland, Germany, Ghana, Guatemala, Guyana, Indonesia, Iran, Iraq, Italy, Kenya, Kuwait, Lebanon, Lesotho, Liberia, Malaysia, Namibia, Netherlands, New Zealand, Niger, Nigeria, Papua New Guinea, Poland, Russia, S Africa, Solomon Islands, Spain, Swaziland, Switzerland, Uganda, UK, USA, Vanuatu, Vatican, Vietnam, Zambia, Zimbabwe, Belarus, Cuba, Egypt, Germany, Latvia, Moldova, Mongolia, S Africa, Sweden, Thailand, Turkey, Uzbekistan, Vietnam, India.

FREQUENCIES

2100-2200	Anguilla, Caribbean Beacon	11775am			
2100-2130 vl	Australia, ABC/Alice Spgs	2310do			
2100-2130 vl	Australia, ABC/Katherine	2485do			
2100-2200 vl	Australia, ABC/Katherine	5025do			
2100-2130 vl	Australia, ABC/Tent Creek	2325do			
2100-2200	Australia, Radio	7240as	9500pa	9660pa	11880pa
		12080as	17715pa	21740pa	
2100-2200 vl	Botswana, Radio	3356do	4820do		
2100-2200	Bulgaria, Radio	7535eu	7545eu		
2100-2200 vl	Canada, CBC N Quebec Svc	9625do			
2100-2200	Canada, CFRX Toronto	6070do			
2100-2200	Canada, CFVP Calgary	6030do			
2100-2200	Canada, CHNX Halifax	6130do			
2100-2200	Canada, CKZN St John's	6160do			
2100-2200	Canada, CKZU Vancouver	6160do			
2100-2159	Canada, R Canada Intl	5995af	7235af	9770af	9805af
		11945af	13650af	13690af	15150af
		17820af			
		7170eu			
2100-2156	China, China Radio Intl	5220eu	6950eu	9920eu	11975eu
2100-2130	China, China Radio Intl	15500af			
2100-2200	Costa Rica, RF Peace Intl	15050am	21460am		
2100-2130	Cuba, Radio Havana	13720eu	13750eu		
2100-2127	Czech Rep, R Prague Intl	5930eu	7345va		
2100-2200	Ecuador, HCJB	15115eu	21455am		
2100-2200	Egypt, Radio Cairo	15375af			
2100-2200 mtwhf	Eq Guinea, Radio Africa	7190af	15186af		
2100-2150	Germany, Deutsche Welle	9615af	9670as	9690af	9765as
		11785af	11865af	15275af	
2100-2200	Germany, Overcomer Ministr	11965af			
2100-2200 vl	Ghana, Ghana BC Corp	3366do	4915do		
2100-2200	Guyana, GBC/Voice of	3290do	5950do		
2100-2130	Hungary, Radio Budapest	3975eu	7250eu		
2100-2200	India, All India Radio	7410eu	9650eu	9910eu	9950eu
		11620va	11715eu		
2100-2200 vl	Italy, IRRS	3985va			
2100-2200	Japan, Radio/NHK	6035pa	9725eu	11850pa	13630na
2100-2130	Kenya, Kenya BC Corp	4885do	4935do		
2100-2200 vl	Lesotho, Radio	4800do			
2100-2115	Libera, LCN/R Liberia Intl	5100do			
2100-2200	Malaysia, Radio	7295do			
2100-2200 vl	Namibia, NBC	3270af	3289af		
2100-2200	New Zealand, R NZ Intl	17675pa			
2100-2200 vl	Nigeria, Radio/Ibadan	6050do			
2100-2200 vl	Nigeria, Radio/Kaduna	4770do			
2100-2200	Nigeria, Radio/Lagos	3326do			
2100-2200	North Korea, R Pyongyang	4405as	6575eu	9335eu	11710am
		13760am			
2100-2200 vl	Papua New Guinea, NBC	9675do			
2100-2200	Romania, R Romania Intl	7105eu	9550eu	9690eu	
2100-2130	Serbia, Radio Yugoslavia	6100eu	6185eu		
2100-2200 vl	Solomon Islands, SIBC	5020do			
2100-2130	South Korea, R Korea Intl	6480eu			
2100-2200	South Korea, R Korea Intl	15575eu			
2100-2200	Syria, Radio Damascus	12085na	13605na		
2100-2130	Turkey, Voice of	9525va			
2100-2200	UK, BBC World Service	3255af	3915as	3955eu	5965as
		5975va	6005af	6110as	6180eu
		6190af	6195va	7325eu	9410eu
		9740pa	11835af	12095sa	15400af
		4820eu	5905eu	6020eu	6080eu
		7150na	7205eu	7380eu	7420eu
		9560eu	9610na		
2100-2200	USA, KAIJ Dallas TX	13815na			
2100-2200	USA, KTBN Salt Lk City UT	15590am			
2100-2200	USA, KWHR Naahiehu HI	15405as			
2100-2200	USA, Voice of America	6035af	6040me	6095me	7415af
		11870pa	11975af	13710af	15185pa
		15240af	15410af	15580af	17725af
		17735pa			
2100-2200	USA, WBCQ Monticello ME	7415na			
2100-2200	USA, WEWN Birmingham AL	5825na	5850eu	9385eu	13615na
2100-2200	USA, WGTG McCaysville GA	6890na	9400am		
2100-2200	USA, WHRA Greenbush ME	15460af			
2100-2200	USA, WHRI Noblesville IN	5755am	9495am		
2100-2200	USA, WINB Red Lion PA	13790am			
2100-2200	USA, WJCR Upton KY	7490na	13595as		
2100-2200 as	USA, WRMI/R Miami Intl	9955sa			
2100-2200	USA, WRNO New Orleans LA	15420am			
2100-2200 vl	USA, WSHB Cypress Crk SC	13770eu	15665af		
2100-2200	USA, WWCR Nashville TN	5070na	7435na	9475na	13845na
2100-2200	USA, WYFR Okeechobee FL	7355eu	11580af	15565va	
2100-2200 vl	Vanuatu, Radio	4960do			
2100-2200	Zambia, Christian Voice	3330af	4965af		
2100-2200	Zambia, Natl BC Corp	6165do	6265do		
2100-2200 vl	Zimbabwe, Zimbabwe BC	3306do	4828do		
2115-2145 mtwhfa	Armenia, Voice of	4810va	9965va		

2115-2200	Egypt, Radio Cairo	9900eu			
2115-2130 mtwhf	UK, BBC Caribbean Report	5975ca	15390ca	17715ca	
2130-2200	Albania, R Tirana Intl	7160eu			
2130-2200 vl	Australia, ABC/Tent Creek	4910do			
2130-2200	Belgium, R Vlaanderen Int	13670na			
2130-2200	Guam, AWR/KSDA	13720as			
2130-2200	Iran, VOIRI	6165au	9725as		
2130-2155	Moldova, R Moldova Intl	7520eu			
2130-2145 t f	UK, BBC Calling Falklands	11680sa			

2200 UTC

2200-2300	Anguilla, Caribbean Beacon	6090am			
2200-2300 vl	Australia, ABC/Katherine	5025do			
2200-2300 vl	Australia, ABC/Tent Creek	4910do			
2200-2300	Australia, Radio	17715pa	17795pa	21740pa	
2200-2300	Canada, CBC N Quebec Svc	9625do			
2200-2300	Canada, CFRX Toronto	6070do			
2200-2300	Canada, CFVP Calgary	6030do			
2200-2300	Canada, CHNX Halifax	6130do			
2200-2300	Canada, CKZN St John's	6160do			
2200-2300	Canada, CKZU Vancouver	6160do			
2200-2229	Canada, R Canada Intl	5995va	7235va	9770va	9805va
		11705as	11945va	13690va	15150va
2200-2300	Costa Rica, RF Peace Intl	15050am	21460am		
2200-2245	Egypt, Radio Cairo	9900eu			
2200-2300 mtwhf	Eq Guinea, Radio Africa	7190af	15186af		
2200-2300 vl	Ghana, Ghana BC Corp	3366do	4915do		
2200-2300	Guyana, GBC/Voice of	3290do	5950do		
2200-2230	India, All India Radio	7410eu	9650eu	9910eu	9950eu
		11620va	11715eu		
2200-2230	Iran, VOIRI	6165au	9725as		
2200-2300 vl	Italy, IRRS	3985va			
2200-2225	Italy, RAI Intl	5990as	9675as	11900as	
2200-2215	Liberia, LCN/R Liberia Int	5100do			
2200-2300	Malaysia, Radio	7295do			
2200-2230	Mexico, Radio Mexico Intl	5985na	9705na		
2200-2225	Moldova, R Moldova Intl	7520eu			
2200-2300 vl	Namibia, NBC	3270af	3289af		
2200-2300	New Zealand, R NZ Intl	17675pa			
2200-2300 vl	Nigeria, Radio/Ibadan	6050do			
2200-2300 vl	Nigeria, Radio/Kaduna	4770do			
2200-2300	Nigeria, Radio/Lagos	3326do			
2200-2300 vl	Papua New Guinea, NBC	9675do			
2200-2300 vl	Solomon Islands, SIBC	5020do			
2200-2230	South Korea, R Korea Intl	3980eu			
2200-2300 as	Spain, R Exterior Espana	9595af	9680eu		
2200-2205	Syria, Radio Damascus	12085eu	13605na		
2200-2300	Taiwan, Radio Taipei Intl	5810eu	9985eu		
2200-2300	Turkey, Voice of	9655va	7280eu		
2200-2300	UK, BBC World Service	3955eu	5965as	5975am	6175na
		6195va	7110as	7385as	9590na
		9660as	9915sa	11835af	11955as
		12080pa	12095sa	15400af	
		7120eu	7170eu	9835na	
2200-2300	UK, Merlin Network One	7120eu			
2200-2300	USA, KAIJ Dallas TX	13815na			
2200-2300	USA, KTBN Salt Lk City UT	15590am			
2200-2300	USA, Voice of America	7215as	9770as	9890as	11760as
		15185as	15290as	15305as	17735pa
		17820as			
2200-2230 mtwhf	USA, Voice of America	6035af	7415af	11975af	12080af
		13710af			
2200-2300	USA, WBCQ Monticello ME	7415na			
2200-2300	USA, WEWN Birmingham AL	5825na	5850eu	9385eu	13615na
2200-2300	USA, WGTG McCaysville GA	5085am	6890na		
2200-2300	USA, WHRA Greenbush ME	13760af			
2200-2300	USA, WHRI Noblesville IN	5755am	9495am		
2200-2300	USA, WINB Red Lion PA	13790am			
2200-2300	USA, WJCR Upton KY	7490na	13595as		
2200-2300	USA, WRMI/R Miami Intl	9955sa			
2200-2300	USA, WRNO New Orleans LA	15420am			
2200-2300 vl	USA, WSHB Cypress Crk SC	13770eu	15665af		
2200-2300	USA, WWCR Nashville TN	5070na	7435na	9475na	13845na
2200-2300	USA, WYFR Okeechobee FL	11580af			
2200-2300 vl	Vanuatu, Radio	4960do			
2200-2210	Zambia, Natl BC Corp	6165do	6265do		
2230-2300	Austria, R Austria Intl	5945eu	6155eu	13730af	
2230-2300	Cuba, Radio Havana	9550am			
2230-2257	Czech Rep, R Prague Intl	7345na	9435na		
2230-2300	Sweden, Radio	6065va	7325va		
2240-2250	Greece, Voice of	7475au	9425au		
2245-2300	India, All India Radio	7410as	9705as	9950as	11620as
2245-2300	Vatican State, Vatican R	7305au	9595au	11830au	



## FREQUENCIES

2300-0000	Anguilla, Caribbean Beacon	6090am				2300-0000	UK, BBC World Service	3955eu	5965am	5975am	6035as
2300-0000 vl	Australia, ABC/Katherine	5025do						6175na	6195va	7110as	9590na
2300-0000 vl	Australia, ABC/Tent Creek	4910do						9915sa	11945as	11955as	12095sa
2300-0000	Australia, Radio	9660pa	12080as	17715pa	17795pa			15280as			
		21740pa				2300-0000	UK, Merlin Network One	3985eu	7170eu	9835na	
2300-0000	Bulgaria, Radio	7375na	9485na			2300-0000	Ukraine, R Ukraine Intl	4820eu	5905eu	6020eu	7205eu
2300-0000	Canada, CBC N Quebec Svc	9625do						7420eu			
2300-0000	Canada, CFRX Toronto	6070do				2300-0000	USA, KAU Dallas TX	5810na			
2300-0000	Canada, CFVP Calgary	6030do				2300-0000	USA, KTVN Salt Lk City UT	7510am			
2300-0000	Canada, CHNX Halifax	6130do				2300-0000	USA, Voice of America	7215as	9770as	9890as	11760as
2300-0000	Canada, CKZN St John's	6160do						15185as	15290as	15305as	17735pa
2300-0000	Canada, CKZU Vancouver	6160do						17820as			
2300-2329	Canada, R Canada Intl	5960am	6040am	9535am	9755am	2300-0000	USA, WBCQ Monticello ME	7415na			
		11865am				2300-0000	USA, WGTG McCaysville GA	5085am	6890na		
2300-0000	Costa Rica, RF Peace Intl	15050am	21460am			2300-0000	USA, WHRA Greenbush ME	13760af			
2300-2330	Cuba, Radio Havana	9550am				2300-0000	USA, WHRI Noblesville IN	5755am	9495am		
2300-0000	Egypt, Radio Cairo	9900am				2300-0000	USA, WINB Red Lion PA	11950ca			
2300-2350	Germany, Deutsche Welle	5990as	6010as	6045as	7235as	2300-0000	USA, WJCR Upton KY	7490na	13595as		
2300-0000 s	Germany, Good News World R	9405sa				2300-0000	USA, WRMI/R Miami Intl	9955sa			
2300-0000 vl	Ghana, Ghana BC Corp	3366do	4915do			2300-0000	USA, WRNO New Orleans LA	7355am			
2300-0000	Guam, AWR/KSDA	11775as				2300-0000 vl	USA, WSHB Cypress Crk SC	7510eu	15285sa		
2300-0000	Guyana, GBC/Voice of	3290do	5950do			2300-0000 as	USA, WWBS Macon GA	11900na			
2300-0000	India, All India Radio	7410as	9705as	9950as	11620as	2300-0000	USA, WWCR Nashville TN	3215na	5070na	5935na	7435na
2300-2315	Liberia, LCN/R Liberia Intl	5100do				2300-2345	USA, WYFR Okeechobee FL	11740na			
2300-0000	Malaysia, Radio	7295do				2300-0000 vl	Vanuatu, Radio	4960do			
2300-2330	Mexico, Radio Mexico Intl	5985na	9705na			2300-2305	Vatican State, Vatican R	7305au	9595au	11830au	
2300-2325	Moldova, R Moldova Intl	7520eu				2310-2320	Kyrgyzstan, Kyrgyz Radio	4010do	4050do		
2300-0000 vl	Namibia, NBC	3270af	3289af			2315-0000 vl	Libya, Voice of Africa	15235va	15415va	15435va	
2300-0000	New Zealand, R NZ Intl	17675pa				2330-2359 as	Canada, R Canada Intl	6040am	9535am	11865am	
2300-2330 vl	Nigeria, Radio/Ibadan	6050do				2330-2359	Canada, R Canada Intl	5960na	9755na		
2300-2330 vl	Nigeria, Radio/Kaduna	4770do				2330-0000 vl	Guatemala, Radio Cultural	3300do			
2300-2330	Nigeria, Radio/Lagos	3326do				2330-2335	Israel, Kol Israel	7495va	9395va		
2300-0000	North Korea, R Pyongyang	4405as	11335am	13760am	15130am	2330-0000	Lithuania, Radio Vinius	6120na	9835na		
2300-0000 vl	Papua New Guinea, NBC	9675do				2330-0000	Malaysia, RTM Sarawak	7160do			
2300-0000	Romania, R Romania Intl	6130eu	7195eu	9570na	11830na	2330-0000	Netherlands, Radio	6165na	9845na		
2300-0000	Singapore, R Corp Singapore	6150do				2330-2355	Vietnam, Voice of	5940af	7270af	7400af	9840am
2300-0000 vl	Solomon Islands, SIBC	5020do						12019am			
						2340-2350	Greece, Voice of	7450sa	9400sa	11645sa	
						2345-0000 mtwhf	UK, BBC World Service	3915as			
						1930-1000	Italy, AWR Europe	7230eu			

## SELECTED PROGRAMS

### Sundays

- 2500 Australia, Radio: RA News. See S 0000.
- 2500 Egypt, Radio Cairo: Egyptian Music.
- 2500 RTE Dublin via WRN1 (NAM): News.
- 2500 UK, BBC London (as): The World Today. See S 0000.
- 2502 RTE Dublin via WRN1 (NAM): GAA Sports Results.
- 2505 Egypt, Radio Cairo: The Holy Koran and Its Meaning.
- 2510 Australia, Radio: Correspondents' Report. See S 0030.
- 2510 RTE Dublin via WRN1 (NAM): Nocturne.
- 2515 Egypt, Radio Cairo: News.
- 2330 Australia, Radio: Earthbeat. Peter Jacklyn examines environmental issues of the region from a scientific perspective.
- 2330 Egypt, Radio Cairo: Egyptian Songs.
- 2335 Egypt, Radio Cairo: Interview.
- 2345 Egypt, Radio Cairo: Business Radio.
- 2357 RTE Dublin via WRN1 (NAM): Weather & Sea Area.

### Mondays

- 2300 Australia, Radio: RA News. See S 0000.
- 2300 Egypt, Radio Cairo: Program Preview.
- 2300 RTE Dublin via WRN1 (NAM): News.
- 2300 UK, BBC London (as): The World Today. See S 0000.
- 2302 RTE Dublin via WRN1 (NAM): Tonight with Vincent Browne.
- 2310 Australia, Radio: Asia Pacific. See M 1110.
- 2315 Egypt, Radio Cairo: News.
- 2330 Australia, Radio: Innovations. See S 0230.
- 2330 Egypt, Radio Cairo: Arabic Music.

### Tuesdays

- 2300 Australia, Radio: RA News. See S 0000.
- 2300 Egypt, Radio Cairo: Program Preview.
- 2300 RTE Dublin via WRN1 (NAM): News.
- 2300 UK, BBC London (as): The World Today. See S 0000.
- 2302 RTE Dublin via WRN1 (NAM): Tonight with Vincent Browne.
- 2305 Egypt, Radio Cairo: E-Mail.
- 2310 Australia, Radio: Asia Pacific. See M 1110.
- 2315 Egypt, Radio Cairo: News.
- 2330 Australia, Radio: Arts Australia. Lisa Harris presents reviews and comment on current events within the Australian arts scene.
- 2330 Egypt, Radio Cairo: .

### Wednesdays

- 2300 Australia, Radio: RA News. See S 0000.
- 2300 Egypt, Radio Cairo: Program Preview.
- 2300 RTE Dublin via WRN1 (NAM): News.
- 2300 UK, BBC London (as): The World Today. See S 0000.
- 2302 RTE Dublin via WRN1 (NAM): Tonight with Vincent Browne.
- 2310 Australia, Radio: Asia Pacific. See M 1110.
- 2315 Egypt, Radio Cairo: News.
- 2330 Australia, Radio: Rural Reporter. No information available.
- 2330 Egypt, Radio Cairo: Arabic Music.

### Thursdays

- 2300 Australia, Radio: RA News. See S 0000.
- 2300 Egypt, Radio Cairo: Program Preview.
- 2300 RTE Dublin via WRN1 (NAM): News.
- 2300 UK, BBC London (as): The World Today. See S 0000.
- 2302 RTE Dublin via WRN1 (NAM): Tonight with Vincent Browne.
- 2310 Australia, Radio: Asia Pacific. See M 1110.
- 2315 Egypt, Radio Cairo: News.
- 2330 Australia, Radio: Media Report. See H 0030.
- 2330 Egypt, Radio Cairo: Arabic Music.

### Fridays

- 2300 Australia, Radio: RA News. See S 0000.
- 2300 Egypt, Radio Cairo: Program Preview.
- 2300 RTE Dublin via WRN1 (NAM): News.
- 2300 UK, BBC London (as): The World Today. See S 0000.
- 2304 RTE Dublin via WRN1 (NAM): Sportsnews.
- 2305 Australia, Radio: Book Reading. Serialized readings of the best Australian novels.
- 2305 Egypt, Radio Cairo: The Holy Koran and It's Meaning.
- 2310 RTE Dublin via WRN1 (NAM): Rhythm of the Night.
- 2315 Egypt, Radio Cairo: News.
- 2330 Australia, Radio: Pacific Review. See S 0530.
- 2330 Egypt, Radio Cairo: Arabic Music.
- 2355 RTE Dublin via WRN1 (NAM): Weather.

### Saturdays

- 2300 Australia, Radio: RA News. See S 0000.
- 2300 Egypt, Radio Cairo: .

- 2300 RTE Dublin via WRN1 (NAM): News.
- 2300 UK, BBC London (as): The World Today. See S 0000.
- 2304 RTE Dublin via WRN1 (NAM): Sportsnews.
- 2305 Australia, Radio: Australia All Over. Join listeners across the island continent as Ian McNamara throws the spotlight on life in Australia.
- 2305 UK, BBC London (as): From Our Own Correspondent. See S 0005.
- 2310 RTE Dublin via WRN1 (NAM): Country Time.
- 2315 Egypt, Radio Cairo: News.
- 2328 Egypt, Radio Cairo: Press Review.
- 2330 UK, BBC London (as): Variable Music Feature. See T 0530.
- 2335 Egypt, Radio Cairo: The Civilization of Islam.
- 2344 Egypt, Radio Cairo: Faces.
- 2355 RTE Dublin via WRN1 (NAM): Weather.
- 2356 Egypt, Radio Cairo: Egyptian Songs.

*Just a note to say I like the new paper in the February issue of MT...now that I have gotten used to it and am not trying to "separate the pages that are stuck together." A quality magazine now has even more quality.*

**Ron Biddle**

## Bibliography on the Sun and Related Subjects. (Part 1)

In the past few years I have been getting requests for a list of references on the subject of the sun, auroras, radio propagation and other related subjects.

The following list is not complete but should help you discover and explore the various topics. Some books are out of print, but your library should be able to help you find them and possibly get them for you via the inter-library loan system.

As the sunspot numbers are constantly increasing, chances are that the auroras will become prevalent and that magnetic storms will also intensify. So when conditions are not good for DXing, pick up a good book on the subject of propagation (or switch to DXing the mediumwave and FM/TV bands)!

This original list was compiled by IPS in Australia and is reprinted here with permission.

### ■ The Sun - General Information

*Secrets of the Sun*, Ronald Giovanelli, published by Cambridge University Press, 1984, ISBN 0-521-25521-X.

Good summary of all aspects of the sun and its features.

*Beginner's Guide to the Sun*, Peter Taylor and Nancy Hendrickson, Kalmbach Publishing Company, 1995, ISBN 0-913135-23-2.

A complete guide to the sun and its influence.

Directed towards the interested novice reader who may, or may not, want to observe the sun personally.

*Guide to the Sun*, Kenneth Phillips, Cambridge University Press, 1992, ISBN 0-521-39483-X.

An excellent book for readers who are somewhat versed in solar phenomena and their terrestrial effects, and have a little maths and physics background.

*The Sun our Star*, Robert Noyes, published by Harvard University Press, ISBN 0-674-85435, 1982.

Very easy reading and good illustrations

*The Face of the Sun*, H. Newton, published by Pelican. An old book with good historical introduction.

*Astrophysics of the Sun*, Harold Zirin, published by Cambridge University Press, 1988, ISBN 0-521-316073.

A lot to offer the advanced student or sophisticated amateur.

### ■ Observing the Sun

*Sundials*, R. Newton Mayall and Margaret Mayall, Sky Publications, ISBN 0-933346-71-9, 1938.

A classic book with everything you could want to know about the subject; reprinted in 1994.

*Observing the Sun*, Peter Taylor, Cambridge University Press, 1991, ISBN 0-521-40110-0.

Suited for beginning observers of sunspots and other white-light phenomena, or those interested in monitoring atmospheric anomalies caused by solar flares.

*Solar Radiophysics: Studies of Emission from the Sun at Metre Wavelengths*, Don McLean and Norman Labrum, published by Cambridge University Press, 1985, ISBN 0-521-25409-4.

## OPTIMUM WORKING FREQUENCIES (MHz)

For the Period 15 April to 14 May 1999 Flux=170 SSN=132

Predictions prepared using ASAPS for Windows®

UTC	00	01	02	03	04	05	06	07	08	09	10	11	12	13	14	15	16	17	18	19	20	21	22	23			
TO/FROM US WEST COAST																											
SOUTH AMERICA	25	25	25	22	20	19	18	17	17	16	15	14	14	17	21	22	23	23	25	26	27	27	25	25			
WESTERN EUROPE	14	13	12	11	11	10	11	12	11	11					14	16	18	17	18	18	19	18	17	15			
EASTERN EUROPE (P)	13	12	13	14	15	16	14	13							14	16	17	17	18	17	16	15	14	13			
MEDITERRANEAN	19	19	18	17	17	16	14	13							14	16	17	18	19	20	20	20	20	20			
MIDDLE EAST (P)	14	15	17	20	19	17	15								14	16	18	19	20	18	17	17	16	15			
CENTRAL AFRICA	21	22	21	19	16	15	14	14	14						15	17	18	20	21	21	22	21	21	21			
SOUTH AFRICA	15	15	13	11	10	10	15	15	15	14					17	20	21	22	22	23	23	24	22	19	17		
SOUTH EAST ASIA (P)	21	21	21	21	21	20	18	16	14	13	13	12	12	12	13	14	16	18	20	21	20	18	17	20			
FAR EAST	20	19	19	20	19	18	16	14	13	13	12	11	11	11	14	15	14	13	15	18	20	20	19				
AUSTRALIA	27	27	28	28	27	24	22	19	18	18	18	15	15	14	14	16	15	14			18	27	29	28			
TO/FROM US MIDWEST																											
SOUTH AMERICA	23	23	21	19	18	17	16	16	15	14	13	13	15	19	21	21	22	22	23	24	24	24	23	23			
WESTERN EUROPE	16	15	14	13	13	12	12	13	12	11				15	16	17	18	18	19	19	20	20	19	18			
EASTERN EUROPE	12	12	12	13	14	14	13								14	16	17	17	18	18	17	15	14	13			
MEDITERRANEAN	19	19	19	17	16	15	14	13						15	16	18	18	19	20	20	20	20	20	20			
MIDDLE EAST (P)	15	15	17	18	17	14									15	17	19	20	21	20	19	18	17	16			
CENTRAL AFRICA	22	22	20	19	16	15	15	15	14						16	18	19	20	21	22	22	21	21	21			
SOUTH AFRICA	15	15	13	11	10	10	16	16	15	14				14	18	21	22	22	22	23	24	23	22	19	17		
SOUTH EAST ASIA (P)	19	20	20	20	18	17									11	11	13	15	17	19	20	21	21	20	18	17	19
FAR EAST	20	20	20	20	18	17	15	13	13	12	12	11	11	12	14	16	16	15	14	16	18	19	19	20			
AUSTRALIA	25	25	26	25	22	20	18	17	17	16	15	14	14	14	16	16	15	14			18	27	27	26			
TO/FROM US EAST COAST																											
SOUTH AMERICA	20	18	17	16	16	15	15	14	13	12	11	14	18	19	20	20	21	22	22	22	21	21	21	20			
WESTERN EUROPE	15	14	13	12	12	11	11	12	11	11	13	14	16	17	18	19	18	19	19	19	18	19	18	16			
EASTERN EUROPE	12	12	11	12	13	12	11						14	15	17	18	19	19	20	19	19	17	15	14	13		
MEDITERRANEAN	19	18	17	16	15	14	14	12					14	16	17	18	18	19	19	19	20	20	20	19			
MIDDLE EAST (P)	16	16	17	16	14	13							15	17	18	19	19	20	20	20	19	19	18	17			
CENTRAL AFRICA	23	21	20	19	16	16	16	15	14	15	18	21	23	23	23	24	24	24	24	24	24	23	24	24			
SOUTH AFRICA	16	15	13	11	10	10	16	15	15	14	17	20	22	23	24	24	24	25	25	24	24	22	19	17			
SOUTH EAST ASIA (P)	20	19	18	16									13	15	17	19	20	21	21	21	20	20	18	17	19		
FAR EAST	20	21	20	18	16	14	13	13	12	11	11	12	14	16	16	16	16	16	15	16	18	19	19	19			
AUSTRALIA	23	23	22	19	18	16	16	16	16	15	14	14	15	16	16	16	15			18	24	23	23				

■ Unfavorable conditions: Search around the last listed frequency for activity.  
(P) denotes circuit across polar auroral zone; reception may be poor during ionospheric disturbances.

An excellent textbook on radio emission from the sun at metre wavelengths.

### ■ The Solar Terrestrial Environment

*The Sun and Solar-Related Terrestrial Disturbances*, Richard Thompson, published by IPS Radio and Space Services, Sydney, Australia.

A comprehensive guide to the sun and its effects on the solar terrestrial environment.

*Glossary of Solar Terrestrial Terms*, published by Space Environment Center, Boulder, USA.

A nice summary of the meaning of terms used in solar terrestrial forecasting.

*Handbook of Geophysics and the Space Environment*, Adolph Jursa (editor), published by US Air Force Geophysics Laboratory, 1985.

A big book and hard to obtain a copy; but a magnificent reference publication on all aspects of the subject.

*Sun, Earth and Sky*, Kenneth Lang, published by Springer-Verlag, ISBN 3-540-58778-0, 1995. A very accessible, well illustrated introduction to Geospace

*Solar Terrestrial Physics*, Syun-ichi Akasofu and Sydney Chapman, published by Oxford University Press, 1972.

An advanced textbook but one of the best

Next month you will have the second part of this bibliography; in the meantime, good DXing.



## OK, Where Do I



**A**h, you're a beginner! Welcome! All of us were once there. Even long-time shortwave listeners can experience difficulty sorting out what's on when.

I can remember how I felt back in the sixties when I first tuned that Heathkit GR-54 — *overwhelmed!* Of course, it was a happy sort of overwhelmed — a seemingly endless adventure willingly embarked upon that always offered the prospect of a new surprise. Even today, I still feel that excitement and sense of anticipation.

"So, old timer," you ask (*Hey, watch it!*), "Where do I start?" Here are a few suggestions.

### ■ How About News?

The single most cited reason given for listening to shortwave is news — the opportunity to gain new perspectives on current events. When public interest in world affairs rises, so does the sale of shortwave radios.

Despite the current criticism you might hear leveled at the **BBC** for its recent "repositionings," the **World Service** remains the premier newsgathering and disseminating broadcasting organization on the planet. The coverage is comprehensive even if every newscast or news program isn't. Apart from the hourly news bulletins, you might try these regular current affairs programs:

**Newshour** (*Daily 1300, 2100*) and **The World Today** (*Daily 2200-0700 depending on stream*) — Of the two, I prefer **Newshour** for its more comprehensive and in-depth approach. **The World Today** has been derided by some as "BBC Lite," which may be too harsh. But its similarity to CNN's approach to news does leave me a bit cold.

**Insight** (*M-F 1645, 2345; T-A 0345*) gives a quarter-hour examination of one topic in the day's news — a comprehensive, concise and well-presented daily briefing.

**Caribbean Report** (*M-F 1100, 1209, 2115*) is the only regular daily program on shortwave focused on this region. (**Radio Habana Cuba** also does considerable reporting on the Caribbean, but does not have the reputation the **BBC** enjoys.)

**Focus on Africa** (*Africa stream, daily 1705; M-F 1830*) and **Network Africa** (*Africa stream, M-F 0330, 0430, 0530, 0630*) are the programs on which Africans say they rely for accurate reporting of events and issues on their continent. That should prove enough of an endorsement for us.

**Outlook** (*M-F 1205, 2305*), the program which has defined the term "news magazine"

for many for decades, is a mixture of hard and soft features, interviews and reports on people, places and events.

### ■ Beyond the BBC

Among the programs of other international broadcasters providing some excellent regional coverage, you might try sampling:

**As It Happens** (*RCI, M-F 2230*) telephones into the world's hot spots for "on the scene" reports and eyewitness accounts of events as they were occurring. Try this one also for a fresh and dispassionate approach to reporting on the United States.

**VOA News Now** (*around the clock*) has also been derided as a CNN-like "light" approach to news. It is worth sampling if only to gain insight into what the world is being told about itself and us by the US's official broadcaster. Also, to be fair, recent efforts have been noted to place an emphasis on third world children's health issues and reduce the repetitiveness of some of the content.

**Newsline** (*R. Netherlands, M-F 2335; T-A 0035, 0435*) is a quarter-hour report where you are likely to hear a perspective or topic unexamined by others.

**Newslink** (*Deutsche Welle, T-A 0105, 0305, 0505*) focuses primarily on Europe with reports, interviews and a continent-wide press review.

**Sixty Degrees North** (*R. Sweden, M-F 1230, 1430; T-A 0230, 0330*) reports on Sweden and the Nordic region with a review segment at the end of each week.

**Asia-Pacific** (*R. Australia, M-H 2310; T-F 0010, 1005, 1105, 1505; A 0030, 0430, 0830, 1030*) provides the most comprehensive and reliable coverage of this region which is home to half the world's population.

**Latin American News and Studio Nine** (*HCJB T-A 0100, 0400*) provides the only regular extended treatment of Central and South America for English-speaking listeners and highlights, in turn, medicine, history, environmental matters, business and travel in Latin America.

If you like phone-in shows, three worth trying are **Newstalk** (*BBC, S1400*), **Australia Talks Back** (*R. Australia, M-F 0310, 1705*) and **Talk to America** (*VOA, M-F 1710*).

### ■ How about Music?

Yes, even a novice knows that shortwave is far from CD quality. But even with its acknowledged imperfections, shortwave provides a depth and range of musical genres unavailable from your local stations and maybe even your local record store. Here are some tuning suggestions:

For an eclectic blend of world and other music, try **Music 52/15** (*R. Netherlands, W*

*0053, 0453*), **Global Village** (*RCI, A 2305*), **Roots and Wings** (*RCI, S 2305*), **Andy Kershaw's World of Music** (*BBC, Africa stream, F 0230; A 1930*) and **The Planet** (*R. Australia, M-F 1315*).

Several listeners I know have a passion for traditional and contemporary African music. **Music Time in Africa** (*VOA African Service, S 1730, 1930*) is a personal favorite.

A powerful French language commercial station broadcasting from Gabon, **Africa Numero Un**, is often well heard at least in the eastern half of North America *between 0500 and 2300 daily on 4890, 9580, 15475 or 17630 kHz*. Much of the station's schedule is filled with a nice variety of African tunes.

**All India Radio** programs a good measure of subcontinental music. I like the instrumental pieces, but have yet to acquire an adequate appreciation for the vocal arrangements. So, too, stations originating from the Muslim nations will provide the listener with copious amounts of Arabic and Middle Eastern music.

### ■ How about your Favorite Places?

A third approach would be to concentrate your listening on stations originating from one or more favorite countries or regions. Listen daily to a particular station to gain a sense of their style of broadcasting, the topics they cover and the aspects of their society or culture they emphasize. Take note of what you like and what you don't. Then move on to another station or nation.

Of course, all this is only the tip of the iceberg! Watch this column from month to month for suggestions in other topic areas or do some further exploring on your own.

Whatever approach you take, use that new radio enthusiastically as a gateway to new experiences.

Until May, good listening!

[Consult *MT's Shortwave Guide* for frequencies. BBC listings are for the Americas/Europe stream unless otherwise indicated. Programs and times are subject to change.]

### IT'S BACK AND BETTER THAN EVER

#### The Worldwide Shortwave Listening Guide

Edited by John Figliozi

A "must" reference for every shortwave program listener!

\$8.99 at all Radio Shack stores.  
Catalog No. 62-1335



# SATELLITE RADIO GUIDE

## INTERNATIONAL SHORTWAVE BROADCASTERS (via satellite)

By Larry Van Horn, MT Assistant Editor

### WRN One English to North America

Galaxy 5, 125 degrees West, transponder 6 (TBS) 3.820 GHz, V-Pol, audio subcarrier 6.80 MHz. WRN programme details can be heard at 0625, 1525 and 1955 Eastern. Program information is also available on TBS Text page 204. You can reach WRN by email at [online@wrn.org](mailto:online@wrn.org) or through their website on the internet at <http://www.wrn.org>. Many programs can also be heard in Canada on *CBC English Overnight*. WRN is relayed 24 hours a day on many cable systems via the CSPAN Audio One Network. All times are U.S. Eastern Time and all programs in English.

ET	Station
0000	Radio Telefis Eireann (RTE) – Dublin, Ireland (Irish Collection)
0100	Swiss Radio International – Berne, Switzerland
0130	Monday-Friday: Channel Africa – Auckland Park, South Africa Saturday: <i>The Way Ahead and New Horizons</i> Sunday: Glenn Hauser's <i>World of Radio</i>
0200	Polish Radio – Warsaw, Poland
0230	Radio Canada International – Montreal, Canada
0300	Radio Australia – Melbourne, Australia
0400	Voice of Russia – Moscow, Russia
0500	Radio Prague – Prague, Czech Republic
0530	Radio Vlaanderen International – Brussels, Belgium (Brussels Calling)
0600	Swiss Radio International – Berne, Switzerland
0630	YLE Radio Finland – Helsinki, Finland
0700	Radio Australia – Melbourne, Australia
0800	Radio Telefis Eireann (RTE) – Dublin, Ireland
0900	Radio Prague – Prague, Czech Republic
0930	Monday-Saturday: Channel Africa – Auckland Park, South Africa Sunday: <i>The Way Ahead and New Horizons</i>
1000	Monday-Saturday: YLE Radio Finland – Helsinki, Finland Sunday: Voice of America <i>Communications World</i> – Washington, DC USA
1030	Radio Vlaanderen International – Brussels, Belgium (Brussels Calling)
1100	Radio France International – Paris, France
1200	Monday-Friday: <i>Caribbean Tempo</i> from CANA Radio Saturday: Glenn Hauser's <i>World of Radio</i> Sunday: <i>Norden This Week and Health Watch</i>
1215	Monday-Friday: Vatican Radio – Vatican City (World News)
1230	Radio Austria International – Vienna, Austria
1300	Monday-Friday: British Broadcasting Corporation – London, England (Europe Today) Saturday: Radio New Zealand International, Wellington Sunday: Radio Denmark – Copenhagen, Denmark (Copenhagen Calling)
1330	Radio Telefis Eireann (RTE) – Dublin, Ireland
1400	Radio Vlaanderen International – Brussels, Belgium (Brussels Calling)
1430	Monday-Saturday: Channel Africa – Auckland Park, South Africa Sunday: Radio New Zealand International, Wellington
1500	Radio Budapest – Budapest, Hungary
1530	Radio Sweden – Stockholm, Sweden
1600	Swiss Radio International – Berne, Switzerland
1630	Polish Radio – Warsaw, Poland
1700	Radio Telefis Eireann (RTE) – Dublin, Ireland
1900	Swiss Radio International – Berne, Switzerland
2000	Radio Australia – Melbourne, Australia
2030	Monday-Friday: Radio Slovakia International – Bratislava, Slovakia Saturday: United Nations Radio: <i>World in Review and Scope</i> Sunday: Network Africa – Johannesburg, South Africa
2100	YLE Radio Finland – Helsinki, Finland
2130	Radio Sweden – Stockholm, Sweden
2200	Radio Prague – Prague, Czech Republic
2230	Radio Austria International – Vienna, Austria
2300	Polish Radio – Warsaw, Poland
2330	Radio Budapest – Budapest, Hungary

### WRN Two Multi-Lingual to North America

Galaxy 5, 125 degrees West, transponder 6 (TBS) 3.820 GHz, V-Polarization, Audio subcarrier 6.2 MHz. Note that some programs listed below are subject to pre-emption without notice. All times are U.S. Eastern Time.

ET	Station
0000	World Radio Network from National Public Radio
0600	YLE Radio Finland – Helsinki, Finland (News in Finnish). On Saturdays a phone-in for children in Finnish until 0630.
0610	YLE Radio Finland – Helsinki, Finland (Easy listening music with announcements in Finnish and English)
0630	YLE Radio Finland – Helsinki, Finland (News of the past 24 hours in Finnish)
0700	Interval signal
0800	Raidio na Gaeltachta (News in Irish)

0900	Radio Prague – Prague, Czech Republic (Programming in Czech)
0927	Interval signal
1000	YLE Radio Finland – Helsinki, Finland (Regional broadcasts from various parts of Finland in Finnish)
1030	YLE Radio Finland – Helsinki, Finland (News in Finnish)
1100	YLE Radio Finland – Helsinki, Finland (Variable programming in Finnish – often light music)
1200	Interval signal
1300	Voice of Russia – Moscow, Russia (Russian Programming)
1400	Radio Vlaanderen International – Brussels, Belgium (Brussels Calling with Dutch programming)
1430	Identification tone
1630	Radio Austria International – Vienna, Austria (German Programming)
1700	Radio Budapest – Budapest, Hungary (Hungarian Programming)
1800	Polish Radio – Warsaw, Poland (Polish programming)
1830	YLE Radio Finland – Helsinki, Finland (Devotional programming in Finnish)
1855	YLE Radio Finland – Helsinki, Finland (News in Finnish)
1900	YLE Radio Finland – Helsinki, Finland (News of the past 24 hours in Finnish)
1925	YLE Radio Finland – Helsinki, Finland (News in Swedish)
1930	YLE Radio Finland – Helsinki, Finland (French programming)
1945	YLE Radio Finland – Helsinki, Finland (Light music in Finnish)
2030	YLE Radio Finland – Helsinki, Finland (Easy listening music). Announcements partially in English. Saturdays a phone-in for children in Finnish
2100	YLE Radio Finland – Helsinki, Finland (Documentaries and Theater of the Air in Finnish). Sunday: Classical music with a preview in English.
2200	YLE Radio Finland – Helsinki, Finland (English programming)
2230	YLE Radio Finland – Helsinki, Finland (Newsroundup in Finnish)
2300	Interval signal
2330	Radio Austria International – Vienna, Austria (German programming)

### WRN One English to Europe

Astra 1B, 19 degrees East, transponder 22 (VH-1) 11.538 GHz, V-Polarization, audio subcarrier 7.38 MHz. All programs in English and WRN program information can be heard daily at 0125 and 2025 UTC. Program information is also available on VH-1 Text page 222, 223, 224. All times BST/UTC+1 Hour (for Central European Time add 1 hour).

BST	Station
0000	Radio Budapest – Budapest, Hungary
0030	Swiss Radio International – Berne, Switzerland
0100	Radio Australia – Melbourne, Australia
0130	Radio Sweden – Stockholm, Sweden
0200	Tuesday-Saturday: National Public Radio <i>All Things Considered</i> (repeat) Sunday/Monday: National Public Radio <i>Weekend Edition</i>
0300	Tuesday-Saturday: Canadian Broadcasting Corporation <i>As It Happens</i> Sunday-Monday: Radio Canada International – Montreal, Canada (World News and Features)
0400	Polish Radio – Warsaw, Poland
0430	Monday-Friday: Radio Budapest – Budapest, Hungary Saturday: Glenn Hauser's <i>World of Radio</i> Sunday: <i>The Way Ahead and New Horizons</i>
0500	Tuesday-Saturday: Public Radio International <i>Market Place</i> Sunday: Channel Africa – Auckland Park, South Africa Monday: Radio Denmark – Copenhagen, Denmark (Copenhagen Calling)
0530	Radio Austria International – Vienna, Austria
0600	Swiss Radio International – Berne, Switzerland
0630	Monday-Friday: Radio Canada International – Montreal, Canada <i>First Edition</i> Saturday: Radio Canada International – Montreal, Canada (World News and <i>Venture Canada</i> ) Sunday: Radio Canada International – Montreal, Canada (World News and <i>The Mailbag</i> )
0700	Tuesday-Saturday: National Public Radio <i>All Things Considered</i> (repeat) Sunday/Monday: National Public Radio <i>Weekend All Things Considered</i> (repeat)
0800	Radio Australia – Melbourne, Australia
0900	Monday-Friday: Radio Budapest – Budapest, Hungary Saturday: Radio New Zealand International, Wellington Sunday: Adventist World Radio
0930	Monday-Friday: Radio Canada International – Montreal, Canada Saturday: <i>The Way Ahead and New Horizons</i> Sunday: Voice of America <i>Communications World</i> – Washington, DC USA
1000	Radio Prague – Prague, Czech Republic
1030	Monday-Saturday: Channel Africa – Auckland Park, South Africa Sunday: Glenn Hauser's <i>World of Radio</i>
1100	Monday-Friday: Radio Australia – Melbourne, Australia (repeat) Saturday: National Public Radio <i>Car Talk</i>



# SATELLITE RADIO GUIDE

## INTERNATIONAL SHORTWAVE BROADCASTERS / SCPC SERVICES

	Sunday: Public Radio International <i>Prairie Home Companion</i> until 1300 UTC/1400 CET
1200	Monday-Friday: National Public Radio <i>Morning Edition</i>
	Saturday: National Public Radio <i>Fresh Air</i>
1300	Monday-Friday: National Public Radio <i>Morning Edition</i>
	Saturday/Sunday: National Public Radio <i>Weekend Edition</i>
1400	Monday-Friday: Radio France International – Paris, France
	Saturday/Sunday: Radio Memphis
1500	Monday-Friday: Voice of Russia – Moscow, Russia
	Saturday: Radio New Zealand International – Wellington
	Sunday: Voice of America <i>Communications World</i> – Washington, DC USA
1530	Adventist World Radio
1600	Radio Australia – Melbourne, Australia
1700	Monday-Friday: Caribbean Tempo from CANA Radio/Vatican Radio – Vatican City (World News)
	Saturday: Glenn Hauser's <i>World of Radio</i>
	Sunday: Radio Denmark – Copenhagen, Denmark (Copenhagen Calling)
1800	Monday-Friday: Radio Slovakia International – Bratislava, Slovakia
	Saturday: United Nations Radio: <i>World in Review and Scope</i>
	Sunday: <i>Norden This Week and Health Watch</i> (News and Sports)
1830	Radio Telefis Eireann (RTE) – Dublin, Ireland
1900	Radio Vlaanderen International – Brussels, Belgium (Brussels Calling)
1930	Monday-Friday: Channel Africa – Auckland Park, South Africa (repeat)
	Saturday/Sunday: Radio Memphis (until 2030 UTC)
2000	Monday-Friday: Radio Budapest – Budapest, Hungary
	Saturday/Sunday: Radio Memphis (continued)
2030	Radio Sweden – Stockholm, Sweden
2100	YLE Radio Finland – Helsinki, Finland
2130	Polish Radio – Warsaw, Poland
2200	Voice of America – Washington, DC USA
2300	Monday-Friday: Public Radio International <i>The World</i>
	Saturday/Sunday: National Public Radio <i>All Things Considered</i>

### WRN Two Multi-Lingual to Europe

Hotbird-4, 13 degrees East, transponder 121 (Quantum TV) 10.933 GHz, H-Polarization, audio subcarrier 7.74 MHz. Note that programs listed below with an asterisk (\*) are subject to pre-emption without notice. All times BST/UTC+1 Hour (for Central European Time add 1 hour).

BST	Station
0000	*WRN1 European schedule
0100	Radio Prague – Prague, Czech Republic
0130	*WRN1 European schedule
0309	Vatican Radio – Vatican City
0745	*WRN1 European schedule
0830	Sunday: Vatican Radio – Vatican City until 1130
0930	Monday-Saturday: Vatican Radio – Vatican City until 1130, except Wednesday to 1200
1130	*WRN1 European schedule except Wednesday
1200	Monday-Friday: Radio Studio Delta
	Saturday/Sunday: *WRN1
1300	Vatican Radio – Vatican City
1530	Monday-Friday: Radio Studio Delta
	Saturday/Sunday: *WRN1 European schedule
1630	Vatican Radio – Vatican City
2230	*WRN1 European schedule
2300	Monday-Friday: Radio Studio Delta
	Saturday/Sunday: *WRN1 European schedule

## Single Channel Per Carrier (SCPC) Services

By Robert Smathers  
roberts@nmia.com

An SCPC transmitted signal is transmitted with its own carrier, thus eliminating the need for a video carrier to be present. Dozens of SCPC signals can be transmitted on a single transponder. In addition to a standard TVRO satellite system, an additional receiver is required to receive SCPC signals.

The frequency in the first column is the 1st IF (typical LNB frequency) and the second column frequency (in parentheses) is the 2nd IF (commercial receiver readout) for the SCPC listing. Both frequencies are in MHz.

### GE-2 Transponder-Vertical 13 (C-band)

1178.70 (81.3) NASA space shuttle audio

### GE-3 Transponder-Horizontal 13 (C-band)

1207.90 (52.1)	Wisconsin Voice of Christian Youth (VCY) America Radio Network – religious programming
1204.25 (55.75)	Wisconsin Voice of Christian Youth (VCY) America Radio Network – religious programming
1204.00 (56.0)	SRN (Salem Radio Network) News
1201.50 (58.5)	Wisconsin Voice of Christian Youth (VCY) America Radio Network – religious programming

1201.30 (58.7)	Wisconsin Voice of Christian Youth (VCY) America Radio Network – religious programming
1189.20 (70.8)	Praise Broadcasting Network – religious
1188.80 (71.2)	Occasional audio
1188.50 (71.5)	Praise Broadcasting Network – religious

### Galaxy 6 Transponder 1-Horizontal (C-band)

1443.80 (56.2)	Voice of Free China (International Shortwave Broadcaster) Taipei, Taiwan
1443.60 (56.4)	KBLA-AM (1580) Santa Monica, CA – Radio Korea
1443.40 (56.6)	Voice of Free China (International Shortwave Broadcaster) Taipei, Taiwan
1438.30 (61.7)	WWRV-AM (1330) New York, NY – Spanish religious programming and music, ID – Radio Vision Christiana de Internacional
1436.50 (63.5)	West Virginia Metro News – network news feeds

### Galaxy 6 Transponder 3-Horizontal (C-band)

1404.80 (55.2)	KOA-AM (850)/KTLK-AM (760) Denver, Colo – news and talk radio
----------------	---

**DIRECT FREQUENCY READOUT  
SCPC AUDIO RECEIVER**  
FULL COMMERCIAL FEATURES



**UNIVERSAL SCPC-200 AUDIO RECEIVER**

- EASY DIRECT FREQUENCY TUNING - 50 TO 90 MHz (LCD)
- SERVICE NAME ON LCD DISPLAY
- DIRECT TRANSPONDER TUNING (LCD DISPLAY)
- MICROPROCESSOR FREQUENCY DISPLAY
- LARGE MEMORY BANK - 50 CHANNELS
- SPEAKER AND LINE OUTPUTS, HIGH QUALITY AUDIO
- C AND KU BAND AGILE - 950 - 1450 MHz
- COMMERCIAL DIGITAL SYNTHESIZER
- AUTOMATIC LNB DRIFT COMPENSATION (ADC)
- 6 BUTTON KEY PAD FOR FAST TUNING
- COMPANDING, 1:1, 2:1, 3:1 (AUTOMATIC)
- BASEBAND 70 MHz OUTPUT
- BANDWIDTH, WIDE / NARROW
- BUILT IN U.S.A. BY THE LEADING SCPC MANUFACTURER
- AUTOMATIC TUNING INDICATORS
- FULL 16 CHARACTER LCD DISPLAY
- DIGITAL FREQUENCY LOCK-ON (DFL)
- DOES NOT DISABLE VIDEO WHEN IN USE

**INTRODUCTORY PRICE \$399.00 plus S & H — CALL: 1 - 614 - 866-4605**

**UNIVERSAL ELECTRONICS, INC.**  
*Communications Specialists*

4555 GROVES RD., SUITE 12, COLUMBUS, OH 43232  
(614) 866-4605 FAX (614) 866-1201

# SATELLITE RADIO GUIDE

## SINGLE CHANNEL PER CARRIER (SCPC) SERVICES

1404.60 (55.4)	WGN-AM (720) Chicago, IL—news and talk radio	1384.40 (75.6)	KOA-AM (850)/KTLK-AM (760) Denver, CO—news and talk radio sports	<b>Anik E2 Transponder 23-Horizontal (C-band)</b>	
1404.40 (55.6)	Illinois News Network—network news feeds/WMVP-AM (1000) Chicago, IL—talk/Chicago Blackhawks NHL radio network/Chicago Bulls NBA radio network	1384.20 (75.8)	WSB-AM (750) Atlanta, GA—news/talk/Atlanta Hawks NBA radio network	1006.00 (54.0)	Societe Radio-Canada (SRC) Radio-AM Network
1404.20 (55.8)	Tribune Radio Networks/Wisconsin Radio Network	1383.70 (76.3)	Motor Racing Network (occasional audio) NASCAR racing	1005.50 (54.5)	Canadian Broadcasting Corporation (CBC) Radio-North (Yukon) service
1402.70 (57.3)	WLAC-AM (1510) Nashville, TN—news and talk/Road Gang trucker program (overnight)	1383.10 (76.9)	KIRO-AM (710) Seattle, WA—news and talk radio	<b>Solidaridad 1 Transponder 1-Vertical (C-band)</b>	
1402.20 (57.8)	NorthWest Ag News Network - Agriculture info for the Pacific Northwest	1382.60 (77.4)	Soldiers Radio Satellite (SRS) network—U.S. Army information and entertainment radio/Army college sports	1447.90 (52.1)	Antenna Radio Noticias
1402.00 (58.0)	Occasional audio	1382.00 (78.0)	Occasional audio	1447.60 (52.4)	Antenna Radio Noticias
1401.50 (58.5)	Agrinet Ag info/USA Radio Network	1381.60 (78.4)	KEX-AM (1190) Portland, OR—news and talk radio/Portland Trailblazers NBA radio network	1447.20 (52.8)	La Grande Cadena Raza
1399.50 (60.5)	Occasional audio	1381.40 (78.6)	Occasional audio	1447.00 (53.0)	XEMZA-AM 560, Manzanillo, Mexico
1399.20 (60.8)	Occasional audio	1381.20 (78.8)	KJR-AM (950) Seattle, WA— sports talk radio/Seattle Supersonics NBA radio network	<b>Anik E1 Transponder 21-Horizontal (C-band)</b>	
1399.00 (61.0)	Sports Byline USA/Sports Byline Weekend	1377.10 (82.9)	In-Touch—reading service	1036.70 (63.3)	In-store music
1398.80 (61.2)	Talk Radio Network (TRN) — talk radio format	1376.00 (84.0)	Kansas Audio Reader Network—reading service	1037.00 (63.0)	In-store music
1398.50 (61.5)	Occasional audio/Denver Nuggets NBA radio network	1375.40 (84.6)	USA Radio Network/Agrinet Agriculture news service	1037.50 (62.5)	In-store music
1398.30 (61.7)	WSB-AM (750) Atlanta, GA— news/talk/Atlanta Hawks NBA radio network	<b>Galaxy 6 Transponder 4-Vertical (C-band)</b>		<b>SBS5 Transponder 2-Horizontal (Ku-band)</b>	
1398.00 (62.0)	Occasional audio	1376.00 (64.0)	Data Transmissions	1013.60 (80.4)	Wal-Mart in-store network
1397.80 (62.2)	Occasional audio/Colorado Avalanche NHL radio network	<b>Galaxy 6 Transponder 6-Vertical (C-band)</b>		1013.20 (80.8)	Wal-Mart in-store network
1397.50 (62.5)	Minnesota Talking Book Radio Network—reading service for the blind	1347.00 (53.0)	WCRP-FM (88.1) Guayama, PR— Spanish language religious programming	1012.80 (81.2)	Sam's Wholesale Club in-store network
1397.10 (62.9)	Wisconsin Radio Network/Wisconsin college sports	<b>Anik E2 Transponder 1-Horizontal (C-band)</b>		1004.50 (89.5)	Wal-Mart in-store network
1396.90 (63.1)	KRLD-AM (1080) Dallas-Ft. Worth, TX — news and talk radio format	1446.00 (54.0)	Canadian Broadcasting Corporation (CBC) Radio—North (Quebec) service	1004.00 (90.0)	Wal-Mart in-store network
1396.70 (63.3)	Radio America Network/Business News Network	<b>Anik E2 Transponder 7-Horizontal (C-band)</b>		1003.60 (90.4)	Sam's Wholesale Club in-store network
1396.40 (63.4)	Georgia News Network (GNN)—network news feeds	1326.00 (54.0)	Canadian Broadcasting Corporation (CBC) Radio—North (Eastern Arctic) service	1003.20 (90.8)	Wal-Mart in-store network
1396.00 (64.0)	WHO-AM (1040) Des Moines, IA—talk radio/Iowa News Network	<b>Anik E2 Transponder 13-Horizontal (C-band)</b>		<b>RCA C5 Transponder 3-Vertical (C-band)</b>	
1395.80 (64.2)	WTMJ-AM (620) Milwaukee, WI—talk radio/Milwaukee Bucks NBA radio network	1206.00 (54.0)	Canadian Broadcasting Corporation (CBC) Radio—North (MacKenzie) service	1404.60 (55.4)	Wyoming News Network—network news feeds
1395.60 (64.4)	WGST-AM/FM (640/105.7) Atlanta, GA ID <i>Planet Radio</i> —news and talk radio	1205.00 (54.5)	Canadian Broadcasting Corporation (CBC) Radio—Occasional feeds/ events	1400.60 (59.4)	Learfield Communications
1395.40 (64.6)	Michigan News Network—network news feeds/Detroit Redwings NHL radio network	<b>Anik E2 Transponder 17-Horizontal (C-band)</b>		1400.40 (59.6)	Learfield Communications/ MissouriNet
1395.00 (65.0)	Occasional audio	1126.00 (54.0)	Canadian Broadcasting Corporation (CBC) Radio—North (Western Arctic) service	1400.20 (59.8)	Occasional audio
1394.70 (65.3)	WJR-AM (760) Detroit, MI—news and talk radio/Michigan News Network	1125.50 (54.5)	Canadian Broadcasting Corporation (CBC) Radio—North (Newfoundland and Labrador) service	1400.00 (60.0)	Learfield Communications
1394.30 (65.7)	Michigan News Network — network news feeds	<b>Anik E2 Transponder 23-Horizontal (C-band)</b>		1396.60 (63.4)	Kansas Information Network/Kansas Agnet—network news feeds
1385.40 (74.6)	WDUQ-FM (90.5) Pittsburgh, PA — Jazz format	1126.00 (54.0)	Canadian Broadcasting Corporation (CBC) Radio—North (Yukon) service	1396.40 (63.6)	Liberty Works Radio Network — talk radio
1384.60 (75.4)	WDUQ-FM (90.5) Pittsburgh, PA — Jazz format	1126.00 (54.0)	Canadian Broadcasting Corporation (CBC) Radio—North (Yukon) service	1396.20 (63.8)	MissouriNet
		1126.00 (54.0)	Canadian Broadcasting Corporation (CBC) Radio—North (Yukon) service	1396.10 (63.9)	MissouriNet
		1126.00 (54.0)	Canadian Broadcasting Corporation (CBC) Radio—North (Yukon) service	1395.90 (64.1)	Western Montana Radio Network/ Red River Farm Network
		1126.00 (54.0)	Canadian Broadcasting Corporation (CBC) Radio—North (Yukon) service	1395.70 (64.3)	MissouriNet
		1126.00 (54.0)	Canadian Broadcasting Corporation (CBC) Radio—North (Yukon) service	1386.40 (73.6)	Learfield Communications
		1126.00 (54.0)	Canadian Broadcasting Corporation (CBC) Radio—North (Yukon) service	1386.20 (73.8)	Radio Iowa/Iowa college sports
		1126.00 (54.0)	Canadian Broadcasting Corporation (CBC) Radio—North (Yukon) service	1386.00 (74.0)	United broadcasting Network—talk radio
		1126.00 (54.0)	Canadian Broadcasting Corporation (CBC) Radio—North (Yukon) service	1384.60 (75.4)	Capitol Radio Network
		1126.00 (54.0)	Canadian Broadcasting Corporation (CBC) Radio—North (Yukon) service	1384.00 (76.0)	Occasional audio/ABC Direction Network—network news feeds
		1126.00 (54.0)	Canadian Broadcasting Corporation (CBC) Radio—North (Yukon) service	1383.80 (76.2)	Occasional audio
		1126.00 (54.0)	Canadian Broadcasting Corporation (CBC) Radio—North (Yukon) service	1383.40 (76.6)	Capitol Radio Network
		1126.00 (54.0)	Canadian Broadcasting Corporation (CBC) Radio—North (Yukon) service	1382.90 (77.1)	MissouriNet
		1126.00 (54.0)	Canadian Broadcasting Corporation (CBC) Radio—North (Yukon) service	1382.50 (77.5)	Virginia News Network—network news feeds/Washington Wizards NBA radio network
		1126.00 (54.0)	Canadian Broadcasting Corporation (CBC) Radio—North (Yukon) service	1382.10 (77.9)	Learfield Communications/ MissouriNet/Blues NHL radio network



## TIRED OF WORKING THE LOCAL REPEATER?

Try something **NEW** with your HT!

There's **LOTS OF FUN** waiting for you **RIGHT NOW** on the **AMATEUR RADIO SATELLITES!**

"**TOO COMPLICATED**" you say??? **NOT SO!** Some satellites now in orbit require little more than your HT to work or a shortwave receiver to hear.

**FIND OUT HOW...JOIN AMSAT® TODAY!**

Members receive the bi-monthly, 32 page **AMSAT Journal** and substantial discounts on computer tracking software. For a limited time, new members will receive the 115 page book "Mode S – The Book" by K9EK.

For more information call or write:



The Radio Amateur Satellite Corporation

850 Sligo Avenue, Suite 600  
Silver Spring, Maryland 20910  
301-589-6062, M-F, 10-6 Eastern  
Web Site: "WWW.AMSAT.ORG"

### RADIOTELEX MESSAGES - 25 years of monitoring global teleprinter and data communications!

Summarizes several decades of continuous worldwide radio monitoring between 1974 and 1998, and gives an expert's insight in dozens of interesting message formats and modern transmission protocols. Covers 1,004 messages and screenshots of 692 utility stations from 136 countries. With its comprehensive coverage of global aeronautical, commercial, diplomatic, government, maritime, meteorological, military, navigation, police, press, public, and secret radiocommunications on shortwave, this manual is not only highly informative but also very amusing. In one word: fascinating! 572 pages · \$ 49 (worldwide seamail included)

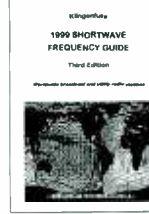

### 1999 SUPER FREQUENCY LIST CD-ROM worldwide broadcast and utility radio stations!



10,400 entries with latest schedules of all clandestine, domestic and international broadcasters on shortwave. 10,800 frequencies from our 1999 Utility Radio Guide (see below). 16,100 formerly active frequencies. All on one CD-ROM for PCs with Windows 3.1™ or Windows™ 95 and 98. You can search for specific frequencies, countries, stations, languages, call signs, and times, and browse through all that data within milliseconds. It can't get faster and easier than this! \$ 42 (worldwide seamail included)

### 1999 SHORTWAVE FREQUENCY GUIDE

Really user-friendly, clearly arranged, and up-to-date! Now includes full details on the future digital modulation broadcast technique, and a solid introduction to real shortwave radio monitoring. Contains more than 21,000 entries with all broadcast and utility radio stations worldwide from our 1999 Super Frequency List on CD-ROM, and a unique alphabetical list of broadcast stations. Two handbooks in one - at a sensational low price! 564 pages · \$ 42 (worldwide seamail included)

### 1999 GUIDE TO UTILITY RADIO STATIONS

Here are the *really* fascinating radio services on SW: aero, diplo, maritime, meteo, military, police, press, and telecom. 10,800 *up-to-date* frequencies from 0 to 30 MHz are listed (improved layout!), plus abbreviations, addresses, call signs, codes, explanations, frequency band plans, meteo/NAVTEX/press schedules, modulation types, all Q and Z codes, and much more! Includes dozens of screenshots of state-of-the-art digital data decoders. 580 pages · \$ 55 (worldwide seamail included)

**Special package price:** CD-ROM + SW Frequency Guide = \$ 67. More package deals available on request. Plus: Worldwide Weather Services = \$ 42. Double CD Recording of Modulation Types = \$ 67. Radio Data Code Manual = \$ 55. Sample pages and colour screenshots can be viewed on our comprehensive Internet WWW site (see below). Payment can be made by cheque or credit card - we accept American Express, Eurocard, Mastercard and Visa. Dealer discount rates available on request. Please ask for our free catalogue with recommendations from all over the world! ©

Klingenfuss Publications · Hagenloher Str. 14 · D-72070 Tuebingen · Germany  
Fax + +49 7071 600849 · Phone + +49 7071 62830 · E-Mail [klingenfuss@compuserve.com](mailto:klingenfuss@compuserve.com)  
internet <http://ourworld.compuserve.com/homepages/Klingenfuss/>

## Swagur Enterprises Now Has a Complete Line of Weather Satellite Equipment for you!



We have joined our marketing efforts with those of Timestep Ltd of England and have everything you will need for Weather Satellites and Inmarsat. This includes complete HRPT, APT or GOES WEFAX systems. Parts are available so you can assemble your own.

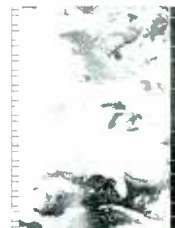

**SWAGUR ENTERPRISES BOX 620035 MIDDLETON, WI 53562 - PHONE/ FAX 608-592-7409**  
**EMAIL: SWAGUR@EXECPC.COM** **WEB SITE: WWW.SWAGUR.COM**

# The Prosat P3500 DVB Digital Receiver

There was a time, just a few years ago, when analog satellite TV channels seemed to be disappearing faster than my chances for winning the lottery. The reason cited was the dreaded “D” word: they’d gone digital. As expected, there was a general wailing and gnashing of teeth as more than a million C-band viewers across the continent threw in the towel and signed up for the ubiquitous mini-dish systems which were promising so much for so little.

Still, those who bothered to hang on to their C-band dishes have found that the digital age did not spell the end to their entertainment; instead, it has proven an enormous benefit. In addition to the 200 analog C-band channels there are hundreds more unencrypted digital channels. And, if you add the audio services to that figure (the way they do on the mini-dish systems), there are over 700 channels, making the big dish the most versatile of all.

### Free-To-Air

While General Instrument’s DigiCipherII (DCII) configured 4DTV receiver was making all the digital waves in the U.S., the lesser-known Digital Video Broadcast (DVB) standard, a staple in Europe, was quickly catching on here as well. Just as its counterpart does, DVB uses the MPEGII standard, delivering crisp pictures and CD quality audio that digital viewers have come to expect. And, as with DCII, signals may or may not be encrypted. When the programmer chooses not to encrypt, the signal is said to be in the Free-To-Air (FTA) mode and is receivable by anyone with a DVB receiver wishing to tune in.

The past two years has seen an explosion of FTA DVB channels which are showing up not only on our domestic C and Ku-band satellites, but also on the many international satellites bridging the Atlantic. DVB viewers are treated to programming from all over Europe as well as North and South America, with all manner of programming in at least eight languages. What’s more, these DVB receivers are reasonably priced, easy to operate, and can be configured into your current C-band system or set up as a stand-alone digital system.

Even though DVB satellite receiver sales top several thousand a month, they remain virtually unknown to most of the satellite industry. That’s because they have been sold almost exclusively to the various communities of foreign nationals and immigrants for whom

digital satellite TV is the only link to their homelands.

### New Prosat 3500

One of the big players in DVB receivers is Prosat which has just released its new model, the 3500v3. There are only three small LEDs to break up the smooth black front of the unit. The LEDs show the receiver’s status: red for “off”; green for “on”; and amber for “locked,” which indicates it’s receiving a digital data stream.

The 3500 has a drop-down door which allows the user to operate the receiver without the remote control. The back of the receiver has an extraordinary array of outputs. The signal output from the receiver can be seen either by using the “S” video output, the UHF modulator which has an output on any channel between 14 and 83 or the video and audio RCA output jacks.

The unit was originally designed for use in the European market and its heritage is seen on the back panel, where there is a SCART (Smart Card) connection for which there is no American use, and the UHF modulator jacks which have Euro-style connectors, though “F” connector adaptors are provided. Even the power plug has a Euro-adaptor though it does operate on 110 volts. The back panel also features a VHF antenna input connection, to attach your

### PHOTO 1



Photo Courtesy: Ken Reitz

1) The Prosat 3500 v.3 is sleek and small (15" W x 10.5" x D 2.75" H) with  
2) a drop down front panel which hides all the buttons needed to operate the receiver.

### PHOTO 2



Photo Courtesy: Ken Reitz



PHOTO 3: The rear panel has a variety of connectors for importing data and outputting video and audio. Photo courtesy: Ken Reitz

outdoor antenna, and two data ports labeled “high speed” and “low speed.” These ports are used to input the latest receiver data which can be downloaded from a website run by Prosat’s distributor.

The 3500 has a full featured infrared (IR) remote control, which is light weight and has a simple layout with well spaced rubber buttons. One thing I look for in a remote control is range: how far and at how great an angle you can be from the receiver and still work the remote. The 3500 remote control has excellent range and a very wide angle for IR reception.

### Plug ‘n Play

The Prosat 3500 comes with a well written manual, but the best instruction comes from the superbly designed on-screen prompts which can tell you how to do everything from point your dish for any given satellite to how to change the digital reception parameters. They couldn’t have made it easier.

When I pulled the P3500 out of the box I realized that I no longer needed the cumbersome “slave harness” to make it easy to combine this receiver with my analog one. That’s because of the previously mentioned rear panel connections.

The next step was to point the dish at a typical satellite loaded with DVB transmissions. I chose Panamsat 5 because of all the interesting foreign broadcasts on that satellite. Once the satellite was acquired, I pressed the “menu” button on the remote, scrolled down to “satellite selection” and hit the “ok” button. The receiver searched the available transponders and stored the digital data pertaining to that satellite in memory.

After searching, I could view any available channels by pushing the “channel up/down” button as you might a VCR. I begin with a video on the screen from CCTV China. I know that because a crawling blue banner at the bottom of the screen tells me. After a few seconds the banner disappears.





**PHOTO 4:** The main menu walks the viewer through every step of reception including how to use the remote, delete satellites and change the whole menu to Chinese characters! Photo Courtesy: Ken Reitz



**PHOTO 5:** Pressing "set up" on the main menu brings up a screen showing where to point the dish for reception and a handy signal meter which indicates signal strength. Photo Courtesy: Ken Reitz



**PHOTO 6:** The "surf" button allows quick access to hundreds of channels. The Prosat 3500 can store up to 600 channels in memory. Photo Courtesy: Ken Reitz

Pressing "up," the next CCTV channel pops on the screen. As I scroll through the channels there are three from CCTV; two from BBC (England); Deutsche Welle TV (Germany); NHK (Japan); two from Spain; RAI (Italy); half a dozen Arabic channels; and a dozen or more feeds including CBS and AP television news feeds. The satellite is brimming with unencrypted digital programming. There are a number of encrypted feeds as well. These show up as a black screen with no audio.

#### ■ Prosat 3500 Features

One of the best features is the "surf" button on the remote. Pressing this brings up a screen

which lines up the alphabet in two strips. Using the left/right buttons one may advance up or down the alphabet. Landing on a letter produces the channel options on three strips below. Using the up/down buttons one may scroll through the channels beginning with that letter. Pressing "ok" on any channel brings that channel to the screen.

It's not long before you'll find you've added several hundred channels. To sort them out, the Prosat has a short list of "preferred channels" available with the "prf+" and "prf-" buttons. This makes finding favorites extremely easy; otherwise you may have trouble locating your most frequently watched channels. Particularly because programmers, who insert the ID data on the data stream, often simply label the channels as "channel one" or "channel 1" or "ch 1." You can appreciate the confusion this feature alleviates.

#### ■ Mastering the P3500

As with using any modern electronic gear, whether it's a computer or shortwave receiver, there's a learning curve. Getting around on the remote control, navigating the on-screen menu, and using the advanced features takes a while to master. It took me a week to figure out how to tune in the extra audio subcarriers, for instance. But, once mastered, you'll find this receiver amazingly easy to operate. The video ranks with the best available, the audio is simply beautiful. Try it on RAI's opera subcarrier, Hispasat's classical music channel, or MCM's European rock music channel: it's as clean as you'll ever hear!

There are a few channels transmitted in the European PAL format, mostly on the Atlantic satellites, and they appear as black and white when tuned in on our sets. That's the only drawback to this receiver, but this is a small point, since such channels represent only a small percentage of available programming.

Other important things to know are that this receiver does not receive DigiCipherII or any other type of digital programming other than DVB standard; it has no decoder module (despite the "smart card" slot behind the front panel door) so programming currently in the clear may not be receivable if encrypted in the future; and there is virtually no "cable" type programming on any of these transmissions.

#### ■ Future at Hand

One of the strongest points to the Prosat is that, with it, you can put together a very inexpensive stand-alone satellite TV system. With a good LNB/feed horn and a well designed dish as small as 4.5 feet, you can set up to receive FTA DVB broadcasts in a very limited space, though in northern parts of North America you'll need a bigger dish. If you have

a functioning C-band system you need only add the receiver to start watching.

If you add a Ku-band LNB you'll see considerably more programming. Adding an actuator arm will also increase your channel capacity, but it isn't necessary if your aim is toward receiving particular programming. For example, in Canada you may want to receive only CTV networks, Newsworld International, and The Weather Network, all of which went digital two years ago and can found on Anik E2 in DVB.

FTA DVB broadcasting brings the viewer a universe of fascinating programming from all over the world — imagine shortwave radio with pictures! It's the future of such broadcasting and the best part is that the programming is free and the receiver is relatively cheap. So, next time you're hunting for something interesting on TV besides HBO reruns, shopping shows, infomercials and phoney sports events, tune into the unexplored side of digital world television.

[The Prosat 3500 retails for around \$370, less 10% discount for MT readers, from PME, Digiear Sales, 6680 Lincoln Avenue Lockport, NY 14094; Fax 716-639-7779; Orders only at 877-463-3212; or visit their website at <http://mpeg2-dvb.com>]

**VIDEO SYNC GENERATOR**

Restores Horizontal and Vertical Sync Lines from Distorted Video

For Free Information Package and Pricing

Call 219-233-3053  
[www.south-bend.net/rcd](http://www.south-bend.net/rcd)

R.C. Distributing, P.O. Box 552, South Bend, IN 46624

**KEEP YOUR C-BAND SYSTEM RUNNING STRONG!**

**Free Buyer's Guide**

**BEST VALUES ON...**

- Receivers, including 4DTV
- Dish Movers & LNBs, all kinds
- Tune-up Kits, Tools & Parts
- Skypac® Programming
- Toll Free Technical Help

1010 Frontier Dr.  
Fergus Falls, MN 56537

Fax: 218-739-4879  
Int'l: 218-739-5231

**800-543-3025**  
[www.skyvision.com](http://www.skyvision.com)

**Skyvision**

## Great Radio Reads

**A**s any of you folks who have subscribed to *MT* for more than a year or so know, April, for reason lost in the sands of time, has become the month where Old Uncle Skip takes some time to review the various books, software or other media that helped to keep him from going stir crazy through the winter months. While past April review columns have had some sort of theme to them, this year the reading presents itself as more of a "mixed grill."

If anyone continues to labor under the false assumption that this hobby is going south, you will see its continues vitality in the number of books annually written for the radio hobby. Almost any radio book short of a graduate level engineering text surely has a few things to offer even the newest beginner. Here are a few that I found intriguing of late.

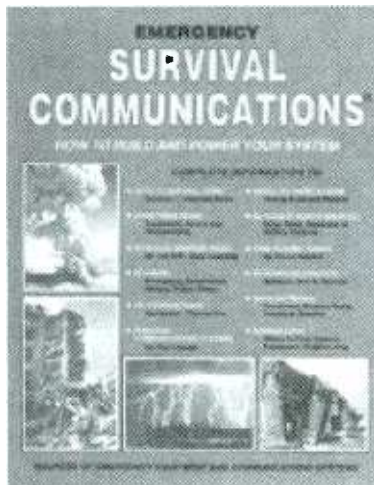

**GUIDE TO EMERGENCY SURVIVAL COMMUNICATIONS**  
How to Build and Power Your System  
by Dave Ingram  
182 Pages; ISBN 0-916661-05-9  
Universal Electronics, Inc.  
4555 Groves Road, Suite 12  
Columbus, OH 43232  
(614) 866-4605; Fax (614) 866-1201

A good radio system that keeps going under any emergency situation is well worth the effort. This book represents itself as a comprehensive source of emergency equipment and communications systems, and as such it comes up to spec. This book takes a wide view of all aspects of the radio hobby including shortwave radio, amateur radio,

scanning, CB and the newer personal communications systems.

It emphasizes the idea that, in emergency and disaster situations, the ability to maintain communications, one or two way, is important. Mr. Ingram gives a good overview of radio systems including hardware, antennas and supportive equipment. Beyond this strong background information, the book goes on to discuss alternative power sources from simple batteries all the way up to self-starting diesel generator systems.

Though that may seem like overkill, I'm sure it would be nice to keep the food cold in the fridge while you're listening in to the world around you. The book goes well beyond the equipment alone, examining various monitoring and operating strategies pertinent to radio use during difficult times. The book includes a chapter on free-playing radios such as the Baygen unit and even includes a few simple design projects for crystal sets.

Unlike some books that go to press half obsolete, this one came with a very interesting feature. A six page "update" of information. The author updates this supplement every three months in order to keep the material as current as possible. This seems quite useful in a hobby where frequencies and suppliers change more often than some folks change their socks. All of this information plus strategies for increasing the storage life of gasoline ... Like I said, this book covers the entire subject.

### ELECTRONIC INVENTIONS AND DISCOVERIES

*Electronics from its earliest beginnings to the present day*  
Fourth Edition by G.W.A. Drummer  
284 Pages; \$40.00 US (appx.)  
Institute of Physics Publishing  
Direc House Temple back  
Bristol, BS1 6BE England

If you remember your history, Radar was one of the major inventions that won World War II. Geoffrey Drummer was one of the folks that worked on the development of Radar back then. He went on to have a hand in the further development of a couple of minor electronic devices such as solid state components and the integrated circuit.

After retiring from the process of invention, he became interested in the history of

invention. This fourth edition of *Electronic Inventions and Discoveries* is just the book for anyone who ever wondered who was responsible for so much of what we enjoy within the radio hobby and the wider world of electronics.

The book takes several tracks to giving the reader a complete notion of the history of electronics. First the book examines the beginning and expansion of electronics followed by the development of componentry from tubes, through transistors and on through integrated circuits. Next comes a series of "Concise Histories of Audio, Radio, Radar, Television, Computers and Industrial Electronics." Each of these histories not only gives insight into the individual subject but sets it into its situation in the world. Chapter ten lists inventions by subject. Further, each sub heading is ordered by date so you can see the flow of things.

The eleventh chapter has to be my favorite. It is a concise (I'll call it comprehensive) description of each invention in date order. Look up Short Wave Commercial Radio Communication and you discover the story of Holland's L.J. van Boetzeelaer. Look up Radio Broadcasting and you find that Mr. Drummer and I concur on the belief that this honor falls to Dr. Reginald Fessenden in 1096, and *not* Dr. Lee de Forest a full year later.

In this section you will learn many things and you will find yourself reading this information not as if it were a textbook but more as if it were an adventure as you see the growth of electronics through the years.

The book follows on with chapters on electronics acronyms and abbreviation. There are also bibliographies covering both inventions and inventors. While you could easily teach a good history course with this book it is just as enjoyable as solid non-fiction reading for anyone interested in the subject of electronics, especially radio.

### THE ARRL ANTENNA BOOK

18th EDITION

Editor R. Dean Straw N6BV  
728 Pages plus 1 software disk (PC format)  
The American Radio Relay League  
225 Main Street, Newington, CT  
06111-1494  
1-888-277-5289



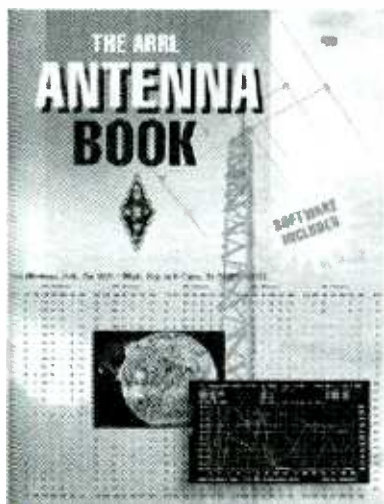

Whether you are a ham or not, the American Radio Relay League's significant contributions to antenna theory apply equally to the general radio hobbyist. This latest 18th edition takes things yet another notch higher. Like its sister publication, *The ARRL Handbook*, the *ARRL Antenna Book* is a comprehensive collection of information on all aspects of antennas. Chapters cover both the hard theory and the practical construction of antennas for every segment of HF, VHF and UHF frequencies. Sections are also devoted to feedlines, propagation and mobile applications.

This book alerted me to an area of study to which I had not given a lot of thought — elevation angles and how they relate to how a signal travels over distance. This study includes indepth statistical information that makes the subject fully understandable, even to a beginner. Also, with the improvement in the sun spot cycle, the new tables on the solar cycle should be of use to any radio hobbyist.

The book once again includes an excellent software package of programs related to antenna design and propagation. If you have any desire to go beyond sticking a length of wire out of a window, this book belongs in your collection.

**THE JOY OF QRP, Strategy for Success**  
 By Adrian Weiss K8EEG-WORSP  
 163 Pages; \$23.00 US  
 ISBN 0-9614139-0-5  
 Milliwatt Books  
 526 N. Dakota St.  
 Vermillion, SD 57069

As you know from other columns, just like our own Rich Arland K7SZ and Ike Kerschner N3IK, I fool around a bit with QRP (low power) operations. In this book you can hear from somebody who doesn't just fool around: Ade Weiss takes his QRP

very seriously. *The Joy of QRP* has been out of print for some years, but I am happy to say that Mr. Weiss has pleased many QRP people by putting this excellent book back into print.

I became involved in this aspect of the radio hobby after that initial print run ended and I was envious of folks who had the old book. Happily I now have my own. This single, densely-packed volume of information can take you from mildly interested in QRP to rabid Millwatt status in short order. Through Ade's study of the subject you will learn the history and traditions of the QRP world, including information on the various clubs and organizations that support this aspect of the radio hobby.

You will also learn how to make QRP work through the study of propagation and operating techniques and strategies that stretch those diminutive signals to the far corners of the globe. Sections discuss building a station around commercial equipment and the joys of building homebrew QRP equipment. This includes the classic QRP design known as the Viking -5, Two-Band Five-Watt Transmitter, and includes printed circuit board patterns. To keep things on the up and up for those millwatt awards, you will learn how to build and operate accurate power measuring equipment.

Every time I pick up this book (which is quite often) I unplug the antenna from my QRO (High Power) rig and plug it into my stock HW-8. If you plan to try your hand at QRP or if you just want to read up on this intriguing aspect of the radio hobby, you need to get *The Joy of QRP*. I'll be listening for you on the lower end of 40 meters.

**PASSPORT TO WEB RADIO, Second Edition**  
 Editor-in-Chief Lawrence Magne  
 144 pages; \$19.95  
 International Broadcasting Services, Ltd.  
 Penn's Park, PA 18943  
 www.passport.com  
 ISBN 0-914941-46-1

I know some traditionalists are already warming up the tar and emptying the feather pillows but I'm going to review my fellow *MT* columnist's great book just the same. Personally, it took me quite a while to warm up to the notion of "bitcasting" or Internet Radio or whatever name finally gets hung on it in the end. This was not because I was a techno-luddite or anything; I just needed a book like Larry's first edition of *Passport to Web Radio* to turn me on to all the possibilities.

Since the first edition was published, netcasting has gone beyond being an experiment and a curiosity, to being a legitimate



adjunct to traditional wireless broadcasting. Further, improved personal computers with a lot more horsepower and updated audio (and video) players make listening to this form of programming a turnkey operation. For example, while I am typing this, I am enjoying a soothing piano concerto by way of WFMT - 98.7 FM, Chicago, IL ([wfmt@broadcast.com](mailto:wfmt@broadcast.com)). *Passport to Web Radio* lists this and over 1500 other programming opportunities.

Grant it, this is not the sport of chasing DX, but it is excellent radio broadcasting that would otherwise be out of my reach, even through the best efforts of a hot receiver, low noise preamplifier, beam antenna, and the mother of all tropospheric ducts. As a radio monitoring hobbyist, nothing beats the rush of battling conditions to catch a rare signal for the purposes of confirmation. But when I'm listening for content, knowledge and enjoyment, I can do without the propagation fading and the static crashes. In other words, as a radio monitoring hobbyist who also likes to play with computers, I can honestly say I have access to the best of both worlds.

In the midst of the excellent program guide, featuring listings of as many of the current Internet broadcasters as publishing deadlines allow, the book is a further study of the impact of this new technology on both the broadcast industry and the listener. The idea that KFI ([www.kfi640.com/programming/index.html](http://www.kfi640.com/programming/index.html)) in Los Angeles, California, may be able to count on Old Uncle Skip in New Jersey listening in has some heavy implications attached to it for advertisers. True, my listening in on the other side of the country may be just a blip on the scope today, but Internet broadcasting is still in its infancy.

*Passport to Web Radio* is a great way to get a handle on this new technology. You'll also hear some great radio programming along the way.

## Scanning the Weather Satellites

If you have any type of scanner that can cover the VHF band (specifically the 137 MHz region), and if you can feed it with an external antenna, there can be no easier and more fascinating way to introduce yourself to the world of satellites than by tuning to those that transmit weather images.

My first experiments with satellites (as an amateur) involved tuning to the amateur radio satellites, but despite the satisfaction of writing programs to decode the telemetry from UoSat-2 (AO-11), and getting intriguing results (showing the variation in the earth's magnetic field in the satellite's orbit), I only felt that I had "arrived" when I decoded my first weather satellite picture. That was nearly 15 years ago!

I would recommend to beginners that they should monitor some weather satellite signals, and then consider whether they want to jump in deeper and set up a full weather satellite station. Monitoring satellites is a very satisfying hobby, and with suitable equipment, you could well find yourself thoroughly absorbed in identifying the different satellites and recognizing their characteristics. After doing this for some time, you build up an expertise and may decide you want to develop the hobby further.

Many readers of *Monitoring Times* already have a general purpose receiver; check to see if it covers the 137 to 138 MHz band – this includes the majority of the weather satellite frequencies listed at the end of this column. Such receivers can "hear" the signals from weather satellites, even when fed by little more than a length of wire running somewhere outside the shack.

Such a minimal system should still bring in the birds – but don't expect to be able to decode these signals and produce clear pictures; this minimal equipment is only suitable for listening – not decoding. In future editions I plan to include features on

the specification of the hardware needed to receive good quality data.

### ■ Resurs lives!

Despite the announcement on the Resurs web site (see below) that Resurs 1-4 would be operational again by late January, I was still surprised to receive a transmission on January 28 at 1033 UTC. Resurs 1-4 has been silent on APT (automatic picture telemetry) frequencies in the 137 MHz band since last August, so the statements indicating a resumption of test transmissions seemed (at least to me) to be optimistic. A report of an APT transmission from Resurs was circulated late January 27th and my first image was received a few hours later. Resurs web site: <http://www.ssc.se/sb/Resurs/index.html>



FIG 1 - Resurs 1-4 January 28 at 1035 UTC

Unlike Meteor 3-5 – which does not transmit APT unless in sunlight – Resurs 1-4 came over the north pole transmitting a blank image. This has happened before. Within a minute or so, the spacecraft entered sunlight and the image quickly proved to be as good a quality as those seen last summer.

The signal strengths received from Meteor, NOAA and Okean satellites, although nominally similar, produce rather different results when run through decoding hardware/software. Differences in the level of amplitude modulation processing on-board each satellite can result in different gray scales. My home system is optimized for

NOAA signals. Meteor weather satellites transmit a slightly stronger signal, so the gray scale for Meteor (or Resurs) satellites is a little distorted, sometimes leading to saturated whites as seen in figure 1.

After the success of Jan 28, I didn't receive transmissions again, until just at presstime. Resurs 1-4 is currently transmitting good APT images on 137.85 MHz when in sunlight. Unfortunately, this does mean that it clashes with Meteor 3-5 when they are both above the same horizon. Perhaps Meteor 3-5 will be switched off?

### ■ Operational Weather Satellites

Meteor 3-5's sunlight-only transmissions continued during the period when its orbit precessed through the plane of twilight. Meteor 2-21 ceased transmissions during mid-January; I suspect that it was switched on to provide northern hemisphere Meteor users with images during the period when Meteor 3-5's transmissions were out of range. By late January, transmissions could be heard during the last minute or so of each northbound (daylight) pass – just up to the latitude where it enters the northern twilight region.

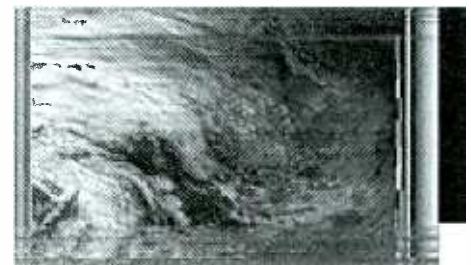

FIG 2 - Meteor 3-5 1610 UTC February 7

Careful checking of the edge of Resurs and Meteor images reveals an interesting difference. Meteor edge telemetry shows a sequence of vertical columns that change structure every several seconds. This is the aperture indicator; a careful check during a pass shows that these six black or white columns can be interpreted as on or off binary states. At the time of switch-on/off,



the dark column is at its widest – interpreted as 11111. The binary nature of this column can be seen; sequences of ones and zeroes can be identified and the equivalent decimal numbers (63, 62, 61 etc.) show that the aperture is at its widest just after (or before) entry to the nighttime part of the orbit.

Resurs images do not (so far) show this number sequence. Adjacent to the gray scale in their images is a vertical column with no additional data.

### ■ NOAAs-12, 14 and 15

The three NOAAs continue to show seasonal changes of illumination characteristic of their individual orbits. The morning NOAA-15 pass, the midday NOAA-14 pass, and the evening NOAA-12 pass show the improving level of contrast in the visible-light section.

### ■ Okean and Sich

Chances are high that newcomers to the weather satellite scene will not yet have heard either of these satellites. They are not really weather satellites (like Meteors or NOAA), but their (rare) transmissions are invariably APT format on 137.40 MHz, so they always attract our attention! Sich-1 and Okean-4 (a.k.a. 1-7) are oceanographic satellites carrying radar and a microwave sounder. Both systems are power-hungry, so transmissions rarely last more than a few minutes.

Several transmissions were reported received from both satellites during January. In early February, I logged some unusual transmissions from Okean-4, made during northbound passes over the mid-Atlantic. Transmissions mostly occur during passes when the spacecraft is over Russia. These were not long enough for me to reconfigure my computer for APT reception.

I receive Primary Data User Station (PDUS) information from Meteosat-7 using a DOS program – and therefore needed a few minutes to load Windows. Following this experience, I decided to set up a dedicated DOS computer for the PDUS monitoring, and another for APT operations.

A few years ago I contacted the Russian Space Monitoring Information Support (SMIS) laboratory, and their staff kindly sent me documents explaining about Okean and Sich operations, including the speci-

cation of spacecraft equipment.

Instrumentation consists of a four-channel scanning radiometer (MSUM), an X-band side-looking synthetic aperture radar (SLR), and a microwave radiometer (RM). Unlike the Meteor telemetry format, transmitted images often include combinations of these instruments. (NOAA images also comprise two wavebands.)

The scanning radiometer has four channels: 0.5-0.6 nm; 0.6-0.7 nm; 0.7-0.8 nm and 0.8-1.0 nm. This last band is similar to NOAA channel-2 imagery, and is usually included in transmissions. Resolution across the track – as seen from Sich’s altitude – reaches 1 km, and along-track resolution reaches 1.7 km. The radar scanner has a carrier frequency of 9.52 GHz (equivalent to a wavelength of 3.15 cm). Its swath width is 450 km, with spatial resolution of 1.3 km and 2.5 km. The microwave radiometer operates in the 36.5 - 36.8 GHz band (equivalent to 8 mm).

My thanks to SMIS for providing detailed information about on-board systems. SMIS laboratory: <http://smis.iki.rssi.ru/> SCANEX <http://scanex.ss.msu.ru/>

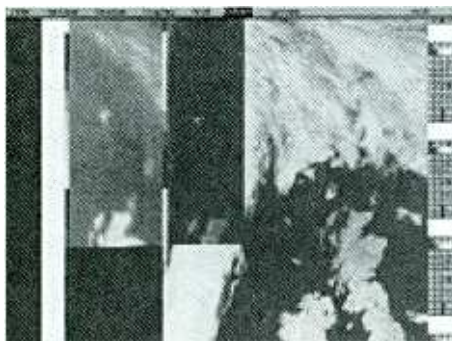

FIG 3 • Okean-4 image August 9

Figure three shows a fairly typical (and complex!) image received from Okean-4 during a southbound pass over Britain some weeks after launch. The right edge shows a column of numbers commencing with “1020.” This number increments each minute; it is the number of minutes elapsed since midnight in Moscow — three hours ahead of UTC. Below this (and probably too small to be reproduced fully) is a small gray scale. Below the scale are ten numbers identifying the state of the on-board equipment.

The image occupying much of this frame is from the (nominally) visible-light band, and shows the northern half of Britain. The small inset picture — showing Scotland —

is a radar image. The left-hand inset is the microwave image — which ends shortly after reaching Scotland.

These are the scanners that apparently drain most of the power during imaging sessions, leading to transmissions being kept short. The radar unit is limited to about 15 minutes operation, and the scanning radiometer for about 30 minutes.

Barely visible in the original image are the two vertical gray scale bars on either side of the microwave image. Transmissions from Okean and Sich are rare, but a few are heard far away from “home” territory — so do listen for them!

### ■ Feng Yun-2

The flow of data from the Chinese geostationary weather satellite Feng Yun-2 has continued. My spot check of their web site produced the latest images from all three wavebands. The water vapor band image was the only one presented without grid lines so I have included it — see figure 4.

<http://nsmc.cma.gov.cn>

FY-2 VAP F 07 FEB 99 05:02 (UTC)

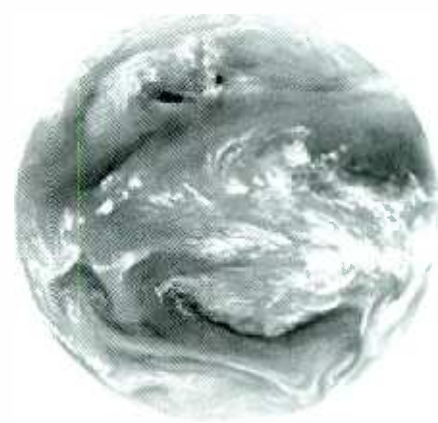

FIG 4 • Feng Yun-2 water vapor image from 0502 UTC on February 7, 1999, courtesy National Satellite Meteorological Center China.

FREQUENCIES	
NOAA-14 transmits APT on 137.62 MHz	
NOAA-12 and -15 transmit APT on 137.50 MHz	
NOAAs transmit beacon data on 137.77 or 136.77 MHz	
Meteor 3-5 transmits APT on 137.85 MHz when in sunlight	
Resurs-1-4 may resume APT on 137.30 MHz	
Okean-4 and Sich-1 sometimes transmit APT briefly on 137.40 MHz	
GOES-8 and GOES-9 use 1691 MHz for weather facsimile	

# The National Disaster Medical System

**A** disaster (manmade or natural) can occur anywhere and anytime. Such catastrophic events quickly overwhelm the resources available to local public safety officials. Imagine for a moment a terrorist attack on a major US city. Suppose the incident involves a major explosive device (larger than that used in the World Trade Center bombing) detonated at a crowded convention center in Portland, Oregon, with an associated container of nitrogen mustard gas.

Local medical personnel are dealing with a patient mix including both trauma and mustard gas contaminated patients. This incident generates over 1,000 casualties, quickly overwhelming the local Portland medical facilities. The Governor of Oregon requests a Federal Disaster Declaration, and the Federal Emergency Management Agency activates the National Disaster Medical System (NDMS). As a result, some patients are evacuated to other areas of the country for treatment using military transport aircraft.

### ■ What is it?

The National Disaster Medical System (NDMS) is a federally coordinated system that

augments the nation's emergency medical response capability. It makes sure that the federal response, when assisting state and local authorities in meeting a major medical or health disaster, is well-coordinated and integrates participating agencies. It also provides support to the military and Veterans Health Administration medical systems in caring for casualties evacuated back to the US from overseas armed conflicts.

Can I hear NDMS communications on my scanner? Absolutely. J. Howell recently posted the following excellent list of NDMS related frequencies to the SCAN-L email list. According to Mr. Howell, the information was compiled from handouts obtained at the 1995 NDMS conference in Nashville, Tennessee.

### ■ More on 120.375 MHz

Our segment in the last edition of *The Fed Files* on the Justice 120.375 MHz air frequency generated a lot of snail and email. Our good friend Tom Kneitel of *Popular Communications* magazine reports that from Long Island this frequency is heard in use by the Washington Air Route Traffic Control Center (ARTCC) at their Falls Church, Virginia, re-

mote site for high altitude air traffic control (ATC) operations.

In those areas of the US where this frequency is being used for ATC operations, there is likely an alternate Justice frequency, and Tom may have found one of them. He reports monitoring Drug Enforcement Administration (DEA) aircraft with air-to-air and air-to-ground communications on 120.775 MHz operating in New Jersey; this may be the alternate frequency in areas where 120.375 isn't available.

Two other areas of the country with known 120.375 MHz ATC activity are at the high altitude sector remote at Rockford, Illinois, for the Chicago ARTCC and Montgomery, Alabama, approach control facility (service into Maxwell AFB). Folks in those areas may want to check for Justice activity on 120.775 MHz in case the same alternate frequency is in use there as well.

And for you adventurous types, here are three more frequencies in the 120 MHz range



**TABLE 1: U.S. GOVERNMENT DISASTER RELATED FREQUENCIES**

Usage	Frequency Input (MHz)	Frequency Output (MHz)	Usage	Frequency Input (MHz)	Frequency Output (MHz)
Health & Human Services Department			Sonoma Mountain Repeater Channel 5	142.350	142.975
Nationwide VHF low	41.470 (Shared Nationwide with the Department of Education and Coast Guard nationwide)		Operations Repeater Channel 6	142.350	143.000
Nationwide Direct Channel 1	413.425		Operations Repeater Channel 7	142.425	142.975
Nationwide Repeater Channel 2	408.050	413.425	Mountain Tamalpais Repeater Channel 8	142.425	143.000 (118.8 PL Tone)
National Disaster Medical System (NDMS)			Region 9-Packet Channel 9	142.375	
NDMS Direct Channel 1	419.600		HF FEMA Calling & Emergency Primary	10.493	
NDMS Repeater Channel 2	409.000	419.600	Disaster Medical Assistance Team (DMAT) California Team (CA-1)		
NDMS Shared Direct Channel 3	418.050		NDMS Direct (OASH) Channel 1	419.600	
NDMS Shared Repeater Channel 4	408.400	418.050	NDMS Repeater (OASH) Channel 2	409.000	419.600
HHS California			NDMS Shared Direct Channel 3	418.050	
San Francisco Local Operations Channel 1	164.300		NDMS Shared Repeater Channel 4	408.400	418.050
Richmond Local Operations Channel 2	171.2375		HHS Direct Channel 5	413.425	
Federal Emergency Management Agency Urban Search and Rescue Cache VHF/UHF			HHS Repeater Channel 6	408.050	413.425
Nationwide Military Liaison Channel 1	138.225		FEMA/US Army Direct Channel 7	418.575	
Nationwide Military Liaison Channel 2	141.725		FEMA/US Army Repeater Channel 8	408.400	418.575
Nationwide Military Liaison Channel 3	141.875		*Interagency Common Direct Channel 9	408.050	
Nationwide Cache Repeater Channel 1	165.6625	164.8625	*Interagency Common Direct Channel 10	408.400	
Nationwide Cache Repeater Channel 2	408.400	418.575	Veterans Affairs Hospital-Hospital Channel 11	406.325 (127.3 PL tone)	
Nationwide Cache Direct Channel 1	418.575		Veterans Affairs Channel 12	409.325	406.325 (127.3 PL tone)
Nationwide Cache Direct Channel 2	164.8625		*Interagency Common Repeat L2 Channel 13	411.400	415.400
FEMA Region 9 California			Veterans Affairs Itinerant Channel 14	409.325	
Operations Direct Channel 1	142.350		Veterans Affairs Itinerant Channel 15	409.400	
Operations Direct Channel 2	142.425		Veterans Affairs Itinerant Channel 16	414.325	
Operations Direct Channel 3	142.975		* California Interagency Mobilization Plan		
Operations Direct Channel 4 143.000					

*Mr. Howell also reports 149.150 MHz in use by several DMATs nationwide. A thousand thanks to Mr. Howell for this fantastic report on a little-known government system.*



used by an entirely different government agency that you might want to program in your scanner. Keep an eye on 120.325, 120.425, and 120.825 MHz and let us know if you hear any non-ATC traffic on these frequencies.

### ■ MT's Government Master File

We continue our exploration of the VHF high government frequency band, started in the December 1998 issue of the *Fed Files*, by profiling the 164.0-164.9875 MHz range in Table 2. See you in two months for another edition of *The Fed Files*. Until then, good hunting.

## TABLE TWO: FEDERAL FREQUENCY ALLOCATIONS: 164-164.9875 MHZ

164.0000	Low power, non-voice up to 11 kHz bandwidth splinter frequency (after 1/1/2005)	164.0000	(No reported activity)	Interior (Nationwide), Park Service, Veterans Affairs (Nationwide)	
164.0031	Low power, non-voice 5 kHz bandwidth splinter frequency	164.2250	Energy (Nationwide) and NASA	164.6875	BLM, Fish/Wildlife Service (Nationwide), Interior (Nationwide), Park Service
164.0062	Low power, non-voice 5-10 kHz bandwidth splinter frequency (until 1/1/2005)	164.2375	(No reported activity)	164.7000	Air Force, Army, Corps of Engineers, Energy, Forest Service (Region 1), GSA, HHS, Labor, NASA, National Science Foundation, Navy, Post Office, U.S. Information Agency (Nationwide), Veterans Administration (Nationwide)
164.0093	Low power, non-voice 5 kHz bandwidth splinter frequency	164.2500	Army, Bureau Indian Affairs, Bureau Reclamation, Energy, FBI, Fish/Wildlife Service, Geologic Survey, Interior (Nationwide), IRS, Park Service, Treasury, TVA	164.7125	BLM, Fish/Wildlife Service (Nationwide), Interior (Nationwide), Park Service
164.0125	Low power, non-voice up to 11 kHz bandwidth splinter frequency (after 1/1/2005)	164.2625	Energy	164.7250	Bureau Indian Affairs, Bureau Reclamation, Corps of Engineers, Energy, FAA, FBI, Fish/Wildlife Service, Geologic Survey, Interior (Nationwide), Park Service, TVA, Veteran Administration
164.0156	Low power, non-voice 5 kHz bandwidth splinter frequency (after 1/1/2005)	164.2750	Energy (Nationwide), FBI, GSA, NASA, Nuclear Regulatory Commission	164.7375	(No reported activity)
164.0250	Air Force, Energy, Environmental Research Labs, FAA, FBI, Forest Service (Region 6), National Bureau of Standards, Marine Fisheries Service, National Ocean Service, National Weather Service, Veterans Administration	164.2875	(No reported activity)	164.7500	Bureau Indian Affairs (Nationwide), Bureau Reclamation, Energy, FBI, Fish/Wildlife Service, Park Service, Navy, Secret Service, TVA
164.0375	Army	164.3000	Air Force, Coast Guard (Nationwide), Customs, Energy (Nationwide), Federal Highway Administration, HHS (Nationwide)	164.7625	Coast Guard
164.0500	Air Force, Corps of Engineers, FAA, FBI, Geologic Survey, National Science Foundation, Capitol Police	164.3125	(No reported activity)	164.7750	Bureau Indian Affairs (Nationwide), Bureau Reclamation, Coast Guard, Corps of Engineers, Customs, Energy (Nationwide), FBI, Fish/Wildlife Service, Interior (Nationwide), Veterans Administration
164.0625	(No reported activity)	164.3250	Air Force, Animal/Plant Inspection, Customs, Energy (Nationwide), FBI, National Science Foundation, Post Office, Capitol Police, Veterans Administration	164.7875	(No reported activity)
164.0750	Air Force, Army, Geologic Survey (Nationwide), Marine Fisheries Service, National Ocean Service (Nationwide), National Weather Service, Veterans Administration	164.3375	(No reported activity)	164.8000	Agriculture (Nationwide), Agriculture Extension Service, Air Force, Animal/Plant Inspection, Bureau Indian Affairs, BLM, Bureau Reclamation, FBI, Fish/Wildlife Service, Forest Service (Region 2/5/6), Geologic Survey, HHS, Interior (Nationwide), Park Service, Secret Service, Capitol Police
164.0875	Interior	164.3500	Corps of Engineers, Energy (Nationwide), FBI, GSA, National Science Foundation, Post Office, Veterans Administration	164.8125	(No reported activity)
164.1000	Air Force, Army, BLM, Corps of Engineers, Customs, Energy, EPA, FBI, Fish/Wildlife Service, Forest Service (Region 1/2/5), IRS, NASA, Park Service, Navy, Nuclear Regulatory Commission, Post Office, Veterans Administration	164.3625	Agriculture (Nationwide) and Energy	164.8250	Agriculture (Nationwide), Agriculture Research Service, Animal/Plant Inspection, Army, Coast Guard, Energy, FAA, Forest Service (All Regions), Geologic Survey, Navy, Post Office, Veterans Administration
164.1125	(No reported activity)	164.3750	Army, Energy (Nationwide), FBI, Forest Service (Region 1), NASA, Park Service	164.8375	Interior (Nationwide)
164.1250	Agriculture (Nationwide), Agriculture Extension Service, Agriculture Research Service, Air Force, Animal/Plant Inspection, Coast Guard (District 9), Corp of Engineers, FBI, Forest Service (All Regions), Geologic Survey, NASA, Park Service, Navy	164.3875	(No reported activity)	164.8406	Low power, non-voice 5 kHz bandwidth splinter frequency (until 1/1/2005)
164.1375	Agriculture (Nationwide), Army, Grain Inspection Service (Nationwide)	164.4000	Energy (Nationwide) and Secret Service (Nationwide-Papa)	164.8437	Low power, non-voice 5-10 kHz bandwidth splinter frequency (until 1/1/2005)
164.1500	Agriculture (Nationwide), Agriculture Research Service, Animal/Plant Inspection, BLM, Corps of Engineers, FBI, Forest Service (Region 1/2/4/5/6/8/9), Geologic Survey, Soil Conservation Service (Nationwide), Veterans Administration	164.4125	(No reported activity)	164.8468	Low power, non-voice 5 kHz bandwidth splinter frequency
164.1625	Interior (Nationwide)	164.4250	Bureau Indian Affairs, Bureau Reclamation (Nationwide), Energy, FBI, Interior (Nationwide), Mine Safety, Park Service, Post Office	164.8500	Low power, non-voice up to 11 kHz bandwidth splinter frequency (after 1/1/2005)
164.1750	Air Force, Army, Bureau Reclamation, Coast Guard, Corps of Engineers, Energy, FBI, Forest Service (Region 1/5), GSA, Geologic Survey, IBWC, Labor, NASA, Park Service, Navy, Post Office, Veterans Administration	164.4375	BLM, Fish/Wildlife Service (Nationwide), Interior (Nationwide), Park Service	164.8531	Low power, non-voice 5 kHz bandwidth splinter frequency (after 1/1/2005)
164.1875	(No reported activity)	164.4500	EPA (Nationwide) and FBI	164.8625	Air Force, Army, Bureau Indian Affairs, Customs (Nationwide), Energy (Nationwide), FBI, FEMA (Nationwide)
164.2000	Air Force, Army, BLM, Bureau Reclamation, Corps of Engineers, Energy, Labor, NASA, Park Service, National Science Foundation, Navy, Post Office, Veterans Administration	164.4625	BLM, Fish/Wildlife Service (Interior-Nationwide), Interior (Nationwide), Park Service	164.8750	Navy
		164.4750	Air Force, Army, Bureau Reclamation (Nationwide), Energy (Nationwide), FBI, Interior (Nationwide), IBWC, Park Service, TVA	164.8875	Secret Service (Nationwide-Oscar)
		164.4875	BLM, Fish/Wildlife Service (Nationwide), Interior (Nationwide), Park Service	164.9000	(No reported activity)
		164.5000	Air Force, Army, Coast Guard, Corps of Engineers, GSA, NASA, National Science Foundation, Navy, Post Office, Veterans Administration	164.9125	Agriculture (Nationwide), Agriculture Extension Service, Agriculture Research Service, Air Force, Animal/Plant Inspection, Coast Guard (Nationwide), Forest Service (Region 1/2/4/5/6), Geologic Survey, Post Office, Soil Conservation Service (Agriculture)
		164.5125	BLM, Fish/Wildlife Service (Nationwide), Interior (Nationwide), Park Service	164.9250	Agriculture Research Service and Forest Service (Region 9)
		164.5250	Bureau Reclamation, BLM, Corps of Engineers, Energy (Nationwide), FBI, Geologic Survey, HHS, Interior (Nationwide), Park Service, National Science Foundation, Nuclear Regulatory Commission	164.9375	Agriculture (Nationwide), Agriculture Extension Service, Animal/Plant Inspection (Nationwide), Army, BLM, Energy, FBI, Forest Service (Region 1/2/4/5/6/8/9), Geologic Survey, Soil Conservation Service, Veterans Administration
		164.5375	BLM, Fish/Wildlife Service (Interior-Nationwide), Interior (Nationwide), Park Service	164.9500	Interior (Nationwide)
		164.5500	Army, BLM, Bureau of Mines, Bureau Reclamation, Coast Guard, Geologic Survey, Justice (Nationwide)	164.9625	Air Force, Army, Corps of Engineers, Customs, Energy, Forest Service (Region 6), HHS, NASA, Navy, Post Office, Veterans Administration
		164.5625	BLM, Fish/Wildlife Service (Nationwide), Interior (Nationwide), Park Service	164.9750	Air Force, Forest Service (Region 2/4/5), NASA
		164.5750	Bureau Indian Affairs, BLM, Bureau Reclamation, Energy, Environmental Research Labs, FBI, Interior (Nationwide), Park Service, TVA	164.9875	Agriculture Research Service, Air Force, Army, Bureau Reclamation, Coast Guard, Corps of Engineers, Energy, Federal Railroad Administration, Forest Service (Region 2/9), Geologic Survey, HHS, Interior (Nationwide), NASA, Park Service, Navy, Post Office, Secret Service, Soil Conservation Service, Veterans Administration
		164.5875	BLM, Fish/Wildlife Service (Interior-Nationwide), Interior (Nationwide), Park Service		
		164.6000	Customs, Energy (Nationwide), FBI, Forest Service (Region 4/6), Park Service, Post Office, Capitol Police, Marshals Service		
		164.6125	BLM, Fish/Wildlife Service (Nationwide), Interior (Nationwide), Park Service		
		164.6250	Animal/Plant Inspection, Army, Bureau Indian Affairs, Federal Railroad Administration, Fish/Wildlife Service, Forest Service (Region 5/8), Interior (Nationwide), Park Service, Post Office, Capitol Police		
		164.6375	BLM, Fish/Wildlife Service (Nationwide), Interior (Nationwide), Park Service		
		164.6500	Secret Service (Nationwide-Tango)		
		164.6625	BLM, Fish/Wildlife Service (Interior-Nationwide), Interior (Nationwide), Park Service		
		164.6750	Bureau Indian Affairs, BLM (Nationwide), Bureau of Mines (Nationwide), Energy, Fish/Wildlife Service, Geologic Survey (Nationwide),		

## ATCC: It's no game!

**W**elcome aboard! Today, we are going to start with a review of an exciting air traffic control (ATC) simulation. In comparing the many ATC simulations that I have used over the years, **ATCC** stands head and shoulders above all of them. The many features that it offers are nothing short of ultra-realistic. To quote the overview page in the user's guide, "Air Traffic Control Center is a highly realistic simulation of actual radar sectors in the New York, Chicago and Los Angeles Air Traffic Control Centers. *You take the position of the radar controller guiding both small and large aircraft into and out of some of the busiest airports in the world!* (as well as in Center airspace between airports! jb)

"This program is intended not so much as a game, but as an accurate simulation of actual air traffic control situations that exist hour by hour in the crowded skies. Whether you are using this simulation as a training tool for a career in Air Traffic Control, or you just want to see what it's like in the controller's chair, **Air Traffic Control Center** will let you experience one of the most mentally challenging occupations in

the world."

Some of the best features this sim includes are pilot communication in standard ATC phraseology and plain English, and a training program that allows you to practice controlling at the sectors before taking tests to become certified to work "live traffic." Once certified, your performance is rated as your career progresses.

ATCC is published by Xavius Software; their web address is: **WWW.Xavius.Com** or 6 Cranbrook Rd. #204, Cockeysville, MD 21030 USA, Tel.(410)667-3597. The ATCC program comes on a CD and is priced at \$59.95. Though the web site says the product I reviewed is out of print, there will be a new version coming early this summer which will include even more sectors and features and also be upgradable for those who already have an earlier version.

You will be able to buy ATCC from Flight Sim Central; their phone number is (800) 477-SIMS. They also have a full complement of other aero simulations, including many add-ons for the latest version of Flight Sim. If you subscribe to *Full Throttle*, you may notice their ad on the back page.

### ■ Murphy's Law

Many of our readers who are pilots have asked me to rerun the examples of Murphy's Law as applied to General Aviation. As you know, we aim to please, so here they are!

- (1) Home base will always be 5 minutes beyond the maximum range of your plane at last planned stop.
- (2) Winds aloft reports will only be accurate in the case of direct headwinds.
- (3) Answers on FAA exams (or ham exams) will be equidistant from your computed answers.
- (4) A dropped tool will hit a spot where it will do maximum damage (Murphy's Law of selective gravitation).
- (5) The component most likely to fail will be the least accessible.
- (6) A fail safe circuit will not only fail, it will destroy others as it does so.
- (7) Operating manuals will express dimensions in the least usable form.

Thanks to Bob Stevens for the above. Remember, those laws also apply to radio.

### ■ Frequencies

A Delta Air Lines Captain from Salt Lake City has contributed a map that Delta pilots use to reference which company radio frequency they should be using. The captain also included some **Salt Lake City International Airport** frequencies (MHz) for our readers in that area:

- 118.300 - East Runway Tower
- 119.050 - Center Runway Tower
- 119.950 - Salt Lake Center Eastbound
- 121.100 - Approach Control North
- 121.650 - Ground Control Runways 35 & 17
- 121.900 - Ground Control Runways 34 & 16
- 122.950 - Unicom
- 123.050 - Lifeflight Helipad
- 124.300 - Approach Control
- 124.900 - Approach Control North
- 125.700 - Approach Control North and West
- 126.650 - Approach Control West
- 127.300 - Clearance Delivery
- 127.700 - Salt Lake Center Westbound
- 128.100 - Approach Control South
- 129.075 - Alpine Airlines Ops
- 129.425 - United Parcel Service
- 129.500 - United Airlines Operations
- 130.100 - Delta Company Ops
- 130.500 - Delta De-Ice Ops
- 130.600 - Southwest SLC Operations

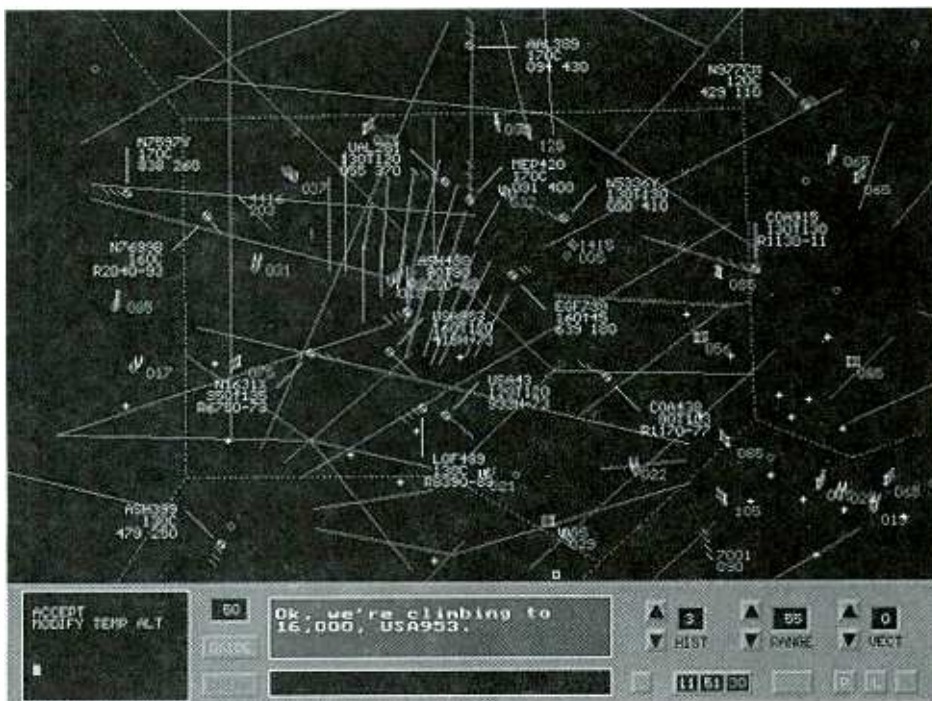



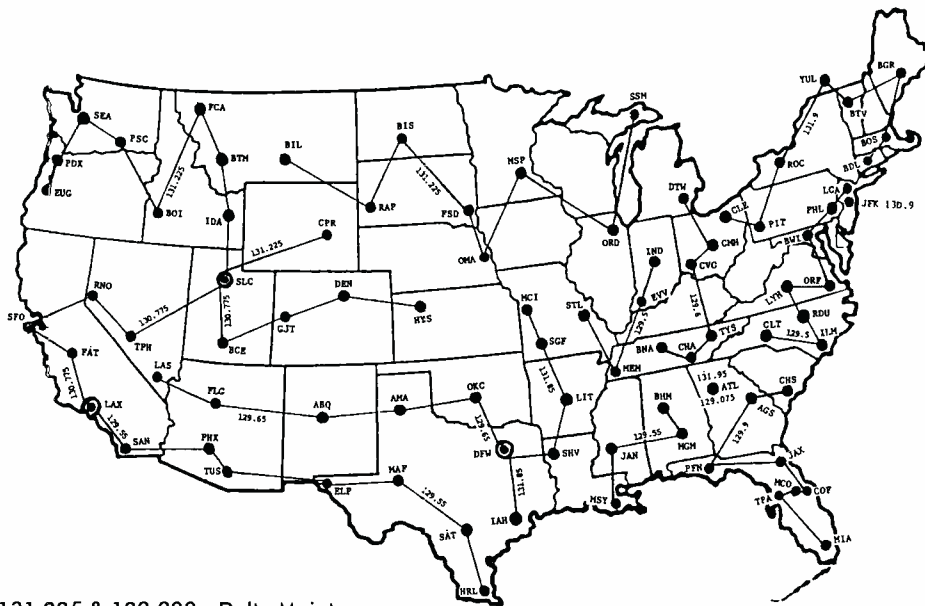

131.225 & 129.900 - Delta Maintenance  
 131.275 - Delta De-Ice  
 131.400 - Skywest De-Ice Ops  
 131.450 - Delta Ramp  
 131.925 - Federal Express Ops  
 132.650 - West Runway Tower  
 134.500 - Approach Control East

Bob Schultz (MN) sends an updated

listing of Minneapolis / St. Paul (MSP)  
**International Airport:**

118.300 - East Runway Tower  
 119.300 - MSP Inner Approach (N or E of Approach Rwy)  
 121.650 - Ground Control Runways 35 & 17  
 121.800 - MSP Ground (N)

121.900 - MSP Ground (S)  
 123.475 - Flight Service Station  
 123.950 - MSP Tower for Rwy 12L/30R  
 124.700 - MSP Departure (S or E of App. Rwy)  
 126.350 - MSP Outer Approach (Planes on this frequency are always handed off to 119.300)  
 126.700 - MSP Tower for Rwy 12R/30L and 4/22  
 126.950 - MSP Inner Approach (S or W of Approach Rwy and Rwy 4/22)  
 127.925 - MSP Departure (N or W of App Rwy)  
 129.925 - Write-ups for Northwest Airlines (NWA) & Continental  
 130.750 - NWA Gate Assignments  
 131.700 - NWA Dispatch  
 131.900 - NWA Dispatch & Maintenance  
 133.200 - MSP Clearance Delivery  
 135.350 - MSP VHF ATIS  
 135.475 - also MSP Outer Approach (Planes on this frequency are always handed off to 126.950)  
 143.750, 143.950, 148.125, 143.900, 148.150 - Civil Air Patrol  
 272.750 - MSP UHF ATIS  
 460.675 - Continental Ground Support  
 460.725 - United Ground Support  
 460.750 - Delta Ground Support  
 460.850 - TWA & NWA Ground Support  
 Thanks, Bob!

Thanks, Captain! That's all for this month, until May, '73 and out!



# We Want Your Trade-ins!

**We'll give you credit against new scanners and receivers!**

Buy that new scanner or shortwave receiver and save \$\$\$ by trading in your unwanted equipment. Grove's excellent trade-in program replaces your older equipment without the hassle, and without the delays and uncertainties of selling it yourself.

**Want to buy previously owned scanners or receivers?**

The radios we take in provide budget-minded buyers a bonanza in low-cost equipment! All of our previously-owned equipment is tested and warranted against defects for 90 days. You can view the list by linking to Bob's Bargain Bin page on our World Wide Web [www.grove-ent.com/hmpgbbb.html](http://www.grove-ent.com/hmpgbbb.html). This list is updated frequently, visit often to catch outstanding bargains!

**At Grove, We're the Trade-in Specialists!**

**Want to discuss a trade?**



7540 Highway 64 West • Brasstown, N.C. 28902  
 800-438-8155 US & Can. • 828-837-9200 • Fax 828-837-2216  
 e-mail: [order@grove-ent.com](mailto:order@grove-ent.com)  
 web: [www.grove-ent.com](http://www.grove-ent.com)

## Beaming In

One of the everlasting mysteries faced by the new AM DXer is “why am I hearing WZZZ on 1300 instead of WYYY? WYYY has twice the power and is 100 miles closer!” “Why is WABC-770 booming in, but WEVD isn’t coming in at all? They’re both 50,000 watts..” Most people think power is the only factor that determines the coverage of an AM station; all 5,000 watt stations should have the same coverage. But it isn’t nearly that simple.

Most U.S. and Canadian stations use directional antennas at night. These antennas radiate better in certain directions than they do in others, and the difference can be dramatic. Let’s take the example of station WWLS-640 in Moore, Oklahoma. This station uses 1,000 watts at night into a directional antenna (protecting 50,000 watt Class A station KFI in Los Angeles). Their “effective radiated power” in the direction of Los Angeles is all of 5 watts! But at an azimuth of 28°, roughly the direction of Minneapolis, the effective power is over 2,000 watts. A listener 50 miles west of Moore would probably hear little or nothing from WWLS, while one 50 miles northeast would get an excellent signal.

How does a directional transmitting array work? Strangely enough, the station intentionally interferes with itself! Of course, if you transmit two signals on the same frequency from two different antennas, they interfere with each other, even if they come from the same transmitter. Since they’re “saying the same thing,” you don’t hear two different programs mixing, and since they’re on exactly the same frequency, you don’t hear any “heterodyne” between the signals. But they do cancel and reinforce each other. By adjusting the proportion of the transmitter’s power sent to each antenna, the distance between the antennas, and the phase (how long it takes the power to reach each antenna), you can predictably adjust the cancellation and reinforcement.

Physically, a directional array doesn’t look any different from a non-directional antenna — except that there’s more than one tower. Almost always, if an AM station has more than one tower, it’s using a directional antenna, at least at night. There will be a “phasing” cabinet somewhere, for adjusting the phase and power split between the antennas.

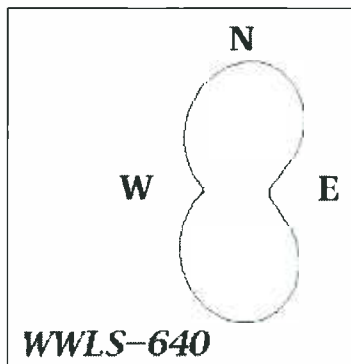

*WWLS-640 Moore, Oklahoma must protect a Los Angeles station from interference; this is why this pattern shows little power beaming to the west.*

This consists of large coils and capacitors, as well as meters for ensuring things are set according to calculations. This cabinet is usually in the building with the transmitter. Some stations are also directional during the daytime with a different radiation pattern; this can lead to a rather complex phasing cabinet with lots of relays!

How can you determine how much power stations are actually radiating in your direction? There are computer programs and a book available that will graph the radiation patterns of AM stations. Robert Carpenter W3OTC has written AMSTNS, shareware (\$20) available at [www.csvhfs.org](http://www.csvhfs.org). AMSTNS is a DOS program but it will run in Windows. It has an optional interface to the DeLorme Street Atlas® CD, which allows you to view the location of the station’s towers on a map. Incidentally, you can also find a similar program for FM and TV stations on this site.

For those who prefer a printed reference, the National Radio Club prints an *AM Pattern Book*, showing the radiation patterns of all directional stations on each frequency. Visit [www.nrcdxas.org](http://www.nrcdxas.org) for more information, or send a 33-cent stamp to NRC Publications, Box 164, Mannsville NY 13661-0164 for a “Product Catalog.”

By the way, there’s another factor that affects the relative coverage of stations. It’s a little-known fact that stations on lower frequencies “get out” further than those higher in the band. WMBS in Uniontown, Pennsylvania, once printed an advertising flyer showing the relative groundwave coverage of sta-

tions on various frequencies and powers. WMBS’s 1,000 watts on 590 kHz covered 162 miles — the same as a 50,000 watt station on 1110 kHz. If you’re listening to WSM-650 during the day in central Alabama and can’t figure out why you can’t hear WLAC-1510, this is your answer.

### ■ Bits and Pieces

Surprisingly, there’s no expanded-band news this month. The Virginia station on 1650 is still testing (and being widely heard) but has not officially come on the air yet.

- CBF-690 Montreal is now off the air. They ran a tape for several days asking listeners to tune to 95.1 FM, then shut down the AM transmitter completely. (Some DXers say this is the first time they’ve ever heard the CBF calls used on the air!) As I write, CBM-940 is still on the air, but I suspect they too will be off by the time you read this. Take advantage of this situation while you can, as applications are being heard for new stations to replace CBF and CBM. I suspect these stations will be back on the air, though with different callsigns and programming, by the end of the year.

- Ed Cichorek N2ZNX in New Jersey wrote with information on a format change at a widely-heard 50,000 watt station. WQEW-1560 in New York City was for many years classical-music outlet WQXR-AM. When nostalgia music station WNEW-1130 became business-news WBBR, WQXR became WQEW and took over the nostalgia music. Now, the station has been leased to Disney for eight years and has begun carrying the “Radio Disney” children’s programming.

- Several readers have sent their expanded-band loggings. Greg Majewski KD1XI in Connecticut heard KCJJ-1630 and WBHD-1680, and the “mystery station” on 1650 with continuous music. (I’m pretty sure this is WHKT in Virginia) Greg is using a Drake R8 with 109-ft. “Carolina Windom” ham antenna and a Palomar 4:1 balun. Tim Caldwell N1RIW on Cape Cod is also hearing the “mystery station,” along with WBAH-1660, WNML-1670 (and tentative WTDY underneath), WMDM-1690, and WCMQ-1700.

What’s beaming its way to your receiver? Write me at Box 98, Brasstown NC 28902-0098, or by email to [w9wi@bellsouth.net](mailto:w9wi@bellsouth.net). Good DX!



## New Editors at Free Radio Weekly

**C**hris Lobdell, founder of the *Free Radio Weekly* internet pirate DX newsletter, has announced his retirement after 160 weekly issues. *FRW* emerged to fill the void caused by the *Cumbre DX* shortwave broadcast internet newsletter's policy of excluding pirate information. Chris and his colleague Niel Wolfish have maintained an excellent service for three years.

Chris' place has already been taken by new rotating editors Niel Wolfish, Harold Frodge, and Greg Majewski, all of whom are regular *MT* readers. *FRW* remains free to contributors, with a modest fee required for those who wish to get the newsletter in their e-mail without sending in logs, QSL's, or other pirate news. If you need more information on the publication, send an e-mail inquiry to Niel Wolfish via his [niel@ican.net](mailto:niel@ican.net) address.

### ■ New ACE Address

Pat Murphy and Steve Rogovich, president and publisher of *The ACE* bulletin of the Association of Clandestine radio Enthusiasts, have announced that the ACE postal address is changing. Correspondence, including subscription inquiries at \$21.00 in the USA, \$24.00 US to Canada and Mexico, and \$40.00 US elsewhere via air mail, should now go to PO Box 15830, Chesapeake, VA 23328. Pat and Steve note that the old address will be phased out toward the end of 1999.

*Monitoring Times* covers unlicensed broadcasting each month, but virtually all serious pirate chasers will also want to take advantage of the excellent information available in *Free Radio Weekly* and *The ACE*. Tell them that *MT* sent you! *FRW* concentrates on pirates, while ACE covers pirates, clandestines, microcasting, numbers stations, and other odd unlicensed radio transmissions.

### ■ Europirates Audible

Mike Prindle says that he recently heard **Laser Hot Hits** on 6220 kHz around 0800 UTC. Our regular contributor Ranier Brandt of Germany notes that plenty of European pirates are active every weekend, mostly using frequencies between 3900-4000, 6200-6300, 6900-7000, and 7330-7500 kHz. North American reception is best from the east coast around North American sunset and European sunrise.

### ■ Illinois 1710 kHz Pirate

Several *MT* readers, including the well-known Adrian Peterson of **Adventist World Radio**, report hearing an unidentified pirate on 1710 kHz, apparently from somewhere in Illinois. With the new expanded medium wave band in place, AM pirates have moved up to this frequency from their former range around 1610 kHz. When Adrian is not producing DX programs or sending out QSL cards for AWR, he's still DXing at the dials of his receiver!

### ■ Clandestine Items

Gary Neal is happy to say that a report to the Voice of Sudan's e-mail address of [sudanvoice@umma.org](mailto:sudanvoice@umma.org) resulted in a QSL certificate in his mailbox in about six weeks. Meanwhile, Martin Schoech's *Clandestine Radio Watch* newsletter notes that the Angolan clandestine **Vorgan** has returned to the air, despite the Angolan peace settlement. Its schedule is 0700-0900 UTC on 5950 kHz, 1200-1430 UTC on 11830 kHz, and 1900-2100 UTC on 7100 kHz. You can check for the latest developments at <http://www.qsl.net/yb0rmi/clang.htm> on Nick Grace's wonderful Clandestine Radio Intel web site.

### ■ Shortwave Pirate Activity

Pirate radio stations heard by our readers last month all used frequencies within 500 kHz of 6955 kHz, typically from two or three hours before sunset until at least 0500 UTC. Morning and afternoon broadcasts increase on the weekends. Programming formats and contact maildrops (when known) are listed here.

**Blind Faith Radio**- Dr. Napalm features all oldies, all the time. (Merlin)

**He Man Radio**- He Man mixes rock music, bagpipes, and sports coverage. (Blue Ridge Summit)

**Indro Calling**- They are one of two active parodies of licensed SWBC station All India Radio. (Providence)

**K-BILLY**- This new one features rock, but little is known about it. (None announced)

**Radio Amazonio**- This Europirate rocker sometimes uses North American relay transmitters. (Ytterby)

**Radio Azteca**- Bram Stoker's DX humor is always hilarious. (Belfast)

**Radio Baghdad**- A cynical Iraq parody with ads for camel sales. (None)

**Radio Bingo**- As the ID implies, this station broadcasts a bingo game. (none, uses radiobingo@chek.com)

**Radio Blandengue**- This South American pirate, with Latin music and Spanish announcers, sometimes uses North American relays. (Merlin)

**Radio Doomsday**- Nemesis' old shows, with excellent production



*Telephoned reports produce WACK's bumper sticker*

values, have returned. (None currently)

**Radio Eclipse**- Steve Mann is back with rock and comedy. (Providence)

**Radio Gerbil**- This one is a Radio Azteca parody. (Providence)

**Radio Inca**- A collage of Spanish music and talk, probably produced by Gringos. (Providence)

**Radio One**- They are the original "numbered" rock oldies station. (Belfast)

**Radio Tornado Worldwide**- A Radio Metallica parody, broadcasting a collage of actual Dr. Tornado remarks. (None)

**SWRS**- The best heard Europirate in North America, using 11470 kHz on weekends. (Wuppertal)

**WACK**- Rock oldies dominates their shows. (None, announces toll-free phone number and sends the bumper sticker that we see here)

**WRX**- Jimmy the Weasel criticizes motherhood and sings profane tunes. (Manomet)

**WRXX**- An elaborate collage of WRX and Radio Metallica audio, similar to Radio Tornado. (None, uses wrxx@hotmail.com)

Reception reports to pirate stations require 3 first class stamps for USA maildrops or \$2 US to foreign addresses. Send your letters to PO Box 1, Belfast, NY 14711, PO Box 28413, Providence, RI 02908; PO Box 109, Blue Ridge Summit, PA 17214; PO Box 293, Merlin, Ontario N0P 1W0; PO Box 1464, Manomet, MA 02345; Box 220342, D-42373, Wuppertal, Germany; and Ostra Porten 29, S-44254 Ytterby, Sweden.

### ■ Thanks!

Your input is always welcome via PO Box 98, Brasstown, NC 28902, or via the e-mail address atop the column. We appreciate material sent in this month by John T. Arthur, Belfast, NY; Shawn Axelrod, Winnipeg, Manitoba; Ranier Brandt, Hoefler, Germany; Jerry Coatsworth, Merlin, Ontario; Ross Comeau, Andover, MA; Dino Davila, St. Louis, MO; Joe Filipkowski, Providence, RI; Harold Frodge, Midland, MI; Paul Griffin, San Francisco, CA; William Hassig, Mt. Prospect, IL; Vince Havrilko, FL; Dan Henderson, Laurel, MD; Zacharias Liangas, Italy; Chris Lobdell, Stoneham, MA; Greg Majewski, Oakdale, CT; Bill McLintock, Minneapolis, MN; Pat Murphy, Norfolk, VA; Gary Neal, Sugar Land, TX; Dick Pearce, Brattleboro, VT; Adrian Peterson, Indianapolis, IN; Mike Prindle, New Suffolk, NY; Al Quaglieri, Albany, NY; Steve Rogovich, Virginia Beach, VA; Robert Ross, London, Ontario; Martin Schoech, Merseburg, Germany; Lee Silvi, Mentor, OH; DJ Stevie, Basel, Switzerland; Niel Wolfish, Toronto, Ontario; and Dr. Zaius.

## April Showers Towers!

**W**ith the arrival of spring, thoughts naturally turn to antenna projects, hamfests and other outdoor pursuits. A favorite sport for many longwave listeners is tracking down local beacons. With this in mind, I thought now might be a good time to review the most common types of antennas you'll see at longwave sites.

At one time, the standard antenna used at nondirectional beacon (NDB) sites was the flat top "Tee" (Fig. 1). This antenna looks similar to a half-wave dipole commonly used by hams, but it has an important difference—the two halves are *not* insulated from each other. Electrically, the antenna is one continuous piece in order to maximize its "metal mass" and thus, its efficiency at low frequencies (LF). An extensive ground system and an antenna tuner make this a fairly effective antenna for beacon service.

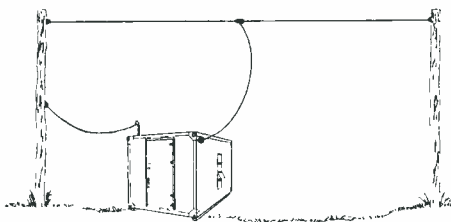

**FIG. 1.** The flat top "Tee" is used at many older beacon sites.

Starting in the mid-1980s, many new or refurbished Federal Aviation Administration (FAA) beacons have been equipped with vertical "top hat" style antennas (Fig. 2). This compact, free-standing design has two advantages — it requires minimal real estate, and it provides improved efficiency over horizontal wire type antennas. A crew of workers can install this antenna in less than a day with the help of a medium-duty bucket truck. Many low frequency experimenters ("lowfers") use homebrew top hat antennas in the 160-190 kHz license-free band.

Yet another form of LF antenna is the "hot tower" (Fig 3). In this arrangement, the tower structure itself acts as the radiating element, and it is isolated from the ground with one or more base insulators. These antennas are found at some beacon sites, and also at utility stations operating below 150 kHz.

### West Coast Net...

David Curry (CA) advises that there is a



**FIG. 2.** Newer beacon sites often employ a vertical top hat antenna.

very active lower group in the Burbank, California, area. Operators gather on Saturday mornings at 9 a.m. local time between 184 and 186 kHz, depending on interference conditions. These transmissions are in single sideband (SSB) mode, so you'll need to turn on your receiver's beat frequency oscillator (BFO) to hear them. According to David, some stations are also active on Sunday afternoons around 4 p.m.



**FIG. 3.** "Hot tower" antennas are common at beacon sites and other LF utility stations

### Loggings

This month's loggings are from Dick Pearce (VT). Dick is using a new wire antenna he put up during the winter months, and from the loggings in Table 1, I'd say his efforts have paid off nicely.

A quick note for those submitting logs — I'll take them any way I can get them, (e-mail or postal) but it is helpful if they are submitted in the form shown below (Freq/ ID/ Location). Feel free to send your loggings (local or DX) to: Below 500 kHz, P.O. Box 98, Brasstown, NC 28902. I'll use as many as possible in a future issue of *MT*.

*See you next month!*

**TABLE 1. BEACON LOGGINGS**

201	DED	Deland, FL
204	YFY	Iqualit, NWT
209	SYS	Stoystown, PA
209	UK	N. Wilksboro, NC
212	UMO	Moa, Cuba
212	UCF	Cienfuegas, Cuba
227	CPC	Whiteville, NC
230	AQE	Alwood, NC
230	UCL	Cayo Largo Del Sur, Cuba
232	GT	Grand Turk, BWI
236	GNI	Grand Isle, LA
237	EZF	Fredricksburg, VA
241	VBW	Bridgewater, VA
248	FRT	Spartanburg, SC
254	LLW	Woodville, NC
256	UNV	Nuevas, Cuba
269	MRH	Beaufort, NC
278	UBA	Baracoa, Cuba
290	EKQ	Monticello, KY
300	ABL	Abalema, COL
311	TBG	Panama City, PAN
315	USR	Simon Reyes, Cuba
325	BHF	Freeport, BAH
325	SKB	St. Kitts, BWI
329	CH	Charleston, SC
332	FIS	Key West, FL
353	HOT	Higuerote, VEN
356	MBV	Mecklenburg, VA
360	KIN	Kingston, JAM
369	ZDX	St. Johns, BWI
376	ZIN	Great Inagua, BAH
382	UCY	Cayojobo, Cuba
385	EMR	Augusta, GA
388	AM	Tampa, FL
392	VEP	Vero Beach, FL
400	CI	Coloe, MI
402	C	Camaguay, Cuba
404	CKI	Kingstree, SC
405	UTX	Jupiter, FL
410	ECB	El Cabo, COL
412	UNG	Nueva Gerona, Cuba
412	MTU	Mitu, COL
412	CTZ	Clinton, NC
415	SLS	Salinas, ECU
423	AU	Auburn, AL
423	SIF	Reidsville, NC
450	PPA	Puerta Plata, DREP
512	HMY	Lexington, OK



# A KEYNOTE SPEAKER from Grove!



Grove's improved **SP-200B Sound Enhancer** is really six products in one. Just look at its many features and capabilities:

- Top quality speaker; also includes headphone jack
  - Hand-crafted hardwood cabinet
  - Adjustable notch/peak filter (30 dB, 0.3-6 kHz)
  - Recorder activator
  - Audio amplifier (2.5 W @ 10% THD, 8 ohms)
  - Audio activated squelch
  - Noise limiter
  - 12 VDC@500 mA (optional AC adaptor available)
- Order PWR 4, \$14.95

## SP-200 SOUND ENHANCER

Housed in a stylish, solid oak cabinet hand crafted in the mountains of North Carolina, the Grove SP-200 is sure to enhance any listening post. The control panel, constructed of sturdy, black aluminum, has been designed for optimum ease and convenience when tuning and refining signals.

The SP-200 combines a powerful audio amplifier, top-of-the-line speaker, and an adjustable filter system to create the most versatile and precise listening environment available to listeners. The unique peak/notch filter system and noise limiter allow the listener to pull clear and distinct signals out of the haze of interference and background noise, while the adjustable bass and treble provide the flexibility to create just the sound you want. Voice, music, CW, and data are enhanced while interference and electrical noise are reduced or even eliminated by the analog audio processor.

The SP-200 also comes equipped with a stereo/mono headphone jack for private listening and an automatic tape activator so that you never have to miss anything.

Try the new Grove SP-200 Sound Enhancer with your receiver, scanner, or transceiver and enjoy the latest in speaker sophistication; you'll agree this is truly a keynote speaker!

**CALL NOW! 800-438-8155**

828-837-9200

Order SPK13

**\$199<sup>95</sup>**

Please add \$12 US Priority Mail or UPS shipping.

**GROVE**

**GROVE ENTERPRISES, INC.**

**1-800-438-8155 US and Canada**

**828-837-9200 • FAX 828-837-2216**

**7540 Highway 64 West • Brasstown, NC 28902-0098**

**e-mail: [order@grove-ent.com](mailto:order@grove-ent.com)**

**[www.grove-ent.com](http://www.grove-ent.com)**

### Touching Bases

**W**e have all come to expect that wireless telephones require a base station. Cordless telephones in the home need a base that is connected to the jack on the wall. Cellular telephones communicate with nearby antenna towers, connecting your call to a cell site base station. The obvious drawback is, when the telephone is out of range of the base station, you're out of touch.

Instead of building towers and antennas every few miles, what if you put the base station inside a satellite orbiting 480 miles overhead?

#### ■ Iridium

That's exactly what a \$5 billion satellite communications venture named Iridium has done. Led by Motorola, Iridium uses sixty-six satellites in low earth orbit to link portable handsets to a dozen ground stations scattered across the globe. After a decade of planning and a year and a half of rocket launches, the world's first handheld global satellite-based personal communications system began commercial operation on November 1, 1998.

Iridium is designed to provide telephone service in areas not covered by terrestrial networks. When a subscriber is in a remote area, the handset operates through the satellite network. When the subscriber moves within range of a compatible terrestrial network the handset operates over that network. The basic satellite phone can be clipped into a "cellular cassette" that wraps around the phone and provides the necessary communications hardware for several types of terrestrial networks. Four different cassettes are available:

- 1 Global System for Mobiles (GSM) at 900 MHz
- 2 Code Division Multiple Access (CDMA)/Advanced Mobile Phone Service (AMPS)/Narrowband AMPS (NAMPS) at 800 MHz
- 3 Time Division Multiple Access (TDMA)/AMPS at 800 MHz
- 4 GSM at 900 and 1800 MHz

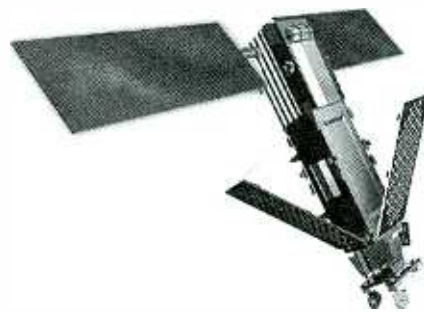

The Motorola Series 9500 satellite phone weighs about 16 ounces and is reminiscent of the first generation "brick" cellular telephones. It is advertised to have two hour talk time and 16 hour standby, and uses a removable, credit card-sized Subscriber Identity Module (SIM) to hold customer information. It transmits digitized speech at 2400 bits per second in L-band between 1616 MHz and 1626.5 MHz at an average power level of half a watt.

Working through local service providers, Iridium sells handsets for about \$3300 and charges anywhere from \$2 to \$10 per minute for air time. In the United States, Sprint PCS is the exclusive provider for Iridium service. Customers are accessible via their Sprint PCS telephone number while traveling internationally, and receive a single bill from Sprint PCS containing all local and international charges.

By the end of 1998 Motorola had produced 35,000 phones and was making about a thousand per day. The only other handset supplier, Kyocera of Japan, has apparently been unable to meet Iridium performance standards and thus does not yet have their phones on the market.

Data and fax services are expected to be available this summer.

Iridium activated their "World Page" service on November 15, 1998, providing worldwide paging to customers for about \$160 per month. A pager retails for \$500, supports up to 200 characters per message, and even works aboard aircraft. PageNet is the exclusive service provider in the United States. At the end

of 1998 Motorola and Kyocera together manufactured 3,500 pagers and have a combined capacity to make 8,000 pagers per month.

Motorola's series 9501 Pager is receive-only with built-in satellite signal strength measurement and supports four frequencies in L-band:

Primary:	1626.437500 MHz
Secondary:	1626.395833
Tertiary:	1626.145833
Quaternary:	1626.104167

Getting such a complicated system off the ground has not been without problems. The original start date of September 23 was delayed due to a "lack of mileage" and insufficient testing, according to Iridium CEO Dr. Ed Staiano. Instead, 2,000 beta testers were selected to perform subscriber trials for five weeks. At that time Dr. Staiano confidently predicted that 100,000 phones would be in use by the end of the year. Despite waived monthly service charges, half-price activation fees, and free handset-to-handset calls, financial statements filed by Iridium in January reported only 3,000 subscribers. Current company predictions place the number of subscribers at the end of this year somewhere between 500,000 to 600,000.

Besides a disappointing subscriber count, it appears Iridium has suffered the loss of a dozen satellites. Nineteen launches orbited a total of 86 satellites, while only 66 are necessary for full operation. At the end of 1998 Iridium reported eight spares in orbit, leaving 12 as non-operational. Last fall a total of seven were known to have failed, so an additional five have apparently become unusable since then.

For those of you who would like a close-up look at an Iridium satellite, visitors to the National Air and Space Museum in Washington, D.C., will be able to see one, donated last year by the Motorola Satellite Communications Group.

#### ■ Globalstar

Another satellite-based personal communications service, Globalstar, has finalized launch plans after losing a dozen satellites last fall. On September 9, 1998, a Zenit-2 rocket launched from Baikonur Cosmodrome in Kazakhstan failed 4-1/2 minutes into flight,



destroying the 12 Globalstar satellites on board.

In January Globalstar announced a new schedule after the United States, Russia, and Kazakhstan signed an agreement covering the launch of U.S. satellites from Baikonur. By the time you read this four satellites should be going up about every month, some on Soyuz rockets from Baikonur and others on Delta II rockets from the United States. A total of 32 satellites are expected in orbit by July, and 52 by December.

The Globalstar system, when completed, will comprise 48 active low earth orbit satellites and a network of gateway earth stations, providing telephone service to remote users. While similar in basic concept to Iridium, Globalstar believes they can offer comparable service at a lower cost by using more complex communications techniques and less expensive satellites. A significant portion of Globalstar's market is expected to be fixed telephone service in areas with little or no existing infrastructure.

Globalstar is an international consortium of companies led by Loral Space and Communications, and has raised \$2.9 billion so far. An additional \$600 million will be needed to complete the system and start commercial service, now slated for September. More than 300,000 user terminals have already been ordered from Ericsson, Qualcomm, and Telital.

System testing has been underway since the launch of eight satellites in February and April of last year, and several public demonstration calls were placed last September. Five gateway earth stations are operational now, with an additional 11 expected to be in operation at the end of this year.

#### ■ AT&T

Back on earth, AT&T's Digital One Rate plan (see the December 1998 *PCS Front Line*) has proven to be very popular. At the end of 1998 there were 850,000 subscribers, all added since the product launch last May. AT&T will spend \$2 billion to upgrade their national network, increasing digital coverage areas from 50 percent to 80 percent.

Overall, AT&T has 7.2 million wireless customers, almost two-thirds of whom use digital phones. 1.29 million new subscribers signed up last year, 440,000 in the fourth quarter alone.

#### ■ Sprint PCS

Sprint PCS also did well, ending 1998 with more than two and a half million subscribers. In January Sprint PCS activated their Chicago system, competing directly with

traditional cellular carriers Ameritech and Cellular One as well as rival PCS provider AT&T Wireless. Their primary advertising claim appears to be the fact that they have a 100 percent digital network, although their coverage areas are somewhat less than the mixed analog and digital areas of AT&T. Sprint PCS has also been troubled by a higher than industry-average churn rate, meaning more customers are leaving Sprint than are leaving other carriers.

#### ■ AirCell

The Federal Communications Commission (FCC) has long prohibited the use of cellular telephones on aircraft in flight, citing interference concerns. A transmitter operating several thousand feet above the ground has a much wider coverage area and can create havoc with a cellular system that expects cell phones to be on or near the ground.

Colorado-based AirCell, Inc., has convinced the FCC to grant a waiver and allow their specially-modified cellular telephones to operate on board aircraft. AirCell uses a number of techniques to reduce the amount of interference they may cause to existing cellular carriers.

Ground stations are located in rural areas, where ambient radio noise is relatively low. This allows the AirCell aircraft transmissions to be very low power, typically five milliwatts or less. AirCell also utilizes horizontal polarization from specially designed aviation antennas, further isolating their transmissions from those of the vertically polarized terrestrial cellular systems. Signaling is done on non-traditional control channels, further limiting non-participating systems from potential confusion.

AirCell operates as a reseller, buying airtime from cellular license holders in the 825 to 894 MHz frequency band. Their ground equipment is co-located with existing cellular base stations, providing a link into the public switched telephone network (PSTN). With antennas pointed slightly upward, a typical ground station has a range of about 80 miles, and AirCell is planning on operating as many as 150 across the United States.

Presently AirCell has reseller agreements with 13 carriers, mostly small ones, as many larger cellular companies oppose the whole idea. AT&T Wireless, AirTouch, BellSouth and others have objected to the waiver on the grounds that the system may interfere with their networks. The FCC's waiver is good for two years, but can be modified or rescinded if it can be proven that AirCell interferes with normal cellular system operation.

Based on their FCC filing, AirCell's primary market is owners and operators of gen-

eral aviation aircraft, who until now have relied almost exclusively on VHF radio voice communication. Currently AirCell serves as a VHF backup, but future plans call for it to deliver weather, air traffic, airport, and flight information to pilots while they are enroute. Such a real-time data link has obvious safety value for pilots, passengers, and people on the ground.

Customers purchase an aircraft-qualified cellular transceiver from AirCell through a local fixed base operator (FBO) or avionics shop and have it installed in their aircraft. The monthly service fee is \$45 and airtime is \$1.75 per minute to any number in the continental United States.

#### ■ Warning for Sony Wireless Telephones

Sony Electronics has informed the FCC that some of their wireless telephones may operate at radio frequency power levels above safety guidelines. Affected telephones were made and distributed in the first half of 1998 and have FCC Identification Numbers L5ACMDB and L5ACMDB2. Although these phones are no longer on the market, approximately 60,000 made it into the hands of consumers. Sony has established a program to notify customers of the potential problem, and to test and adjust the phone should that be necessary. Questions about this program should be directed to Sony Electronics at (888) 914-7669.

That's all for this month. As usual, more information on these and other topics is available on my website at <http://www.decode.com>, and I welcome electronic mail at [dan@decode.com](mailto:dan@decode.com). Until next time, happy monitoring!

**Note to U.S. consumers only:** It is unlawful to import, manufacture, or market cellular-capable or cellular-restorable scanners into the U.S.

**EXPORT ALL OVER THE WORLD**

**boger electronics** *Let's make winners*

**Fastest Windows™ -Remote-Software**  
for AOR- and ICOM- Receivers!  
Speed up to 19 steps/sec.

Scanners, Modifications and more ...  
Visit our WebSite at <http://www.boger.de>

Grundesch 15, D-88326 Aulendorf, Germany  
phone: (+49) 7525/451 fax: (+49) 7525/2382  
e-mail: [bogerfunk@t-online.de](mailto:bogerfunk@t-online.de)

## Dual Polarity Power Supplies

Single-ended power supplies were covered in my March-94 and June-94 columns. Now we take a quantum leap to the dual-polarity power supply — the kind required by certain esoteric op-amp circuits.

Until now, I've ensured that all my op-amp circuits use single-ended power supplies to make it easy on you hard working stiffs who need "maximum bang for the buck." However, I ran into a circuit that you won't want to miss, but it requires a dual polarity power supply: plus and minus 12V. Fortunately, it's not too tough, and there are some easy alternatives.

Next month's project is a four-level FSK data decoder interface that, with a freeware program, can decode some elusive and mysterious signals out there on the airwaves. If you want to jump ahead for what's coming, see Table 1 for a list of Web Site references to this 4LFSKDDI circuit and all that it can do. If you don't need technical guidance, these sites can single-handedly steer you into an exciting sideline of decoding data from the airwaves.

This month, we build a dual polarity power supply. Even if you have no interest in next month's 4LFSKDDI, you can still profit from this month's project.

### Basics of a Dual Polarity Power Supply

A dual polarity power supply consists of two separate power supplies, each referenced to ground, one with a (+) output and the other with a (-) output. Figure 1 graphically depicts the simplest dual polarity power supplies.

There it is, two 9V batteries in series with their common point as ground, and equal but opposite outputs at A and B. Here is what you need to know about this (and most) dual power supplies:

The voltage at A with respect to G is +9V.  
The voltage at B with respect to G is -9V.  
The voltage at A with respect to B is +18V.  
The voltage at B with respect to A is -1V.

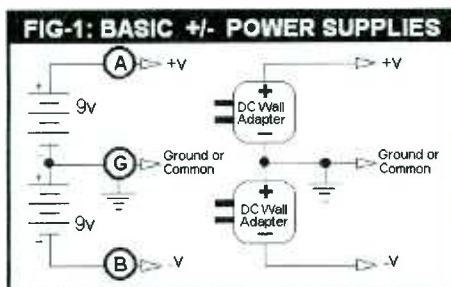

TABLE 1: 4-LEVEL FSK SUPPORT SITES

<http://www.geocities.com/SiliconValley/Horizon/6063/>  
[http://www.qsl.net/pa3eik/4lev\\_fsk.htm](http://www.qsl.net/pa3eik/4lev_fsk.htm)  
<http://www.geocities.com/CapeCanaveral/Launchpad/4039/>  
<http://www.geocities.com/CapeCanaveral/Launchpad/4039/PINFO.HTM>  
<http://www.geocities.com/CapeCanaveral/Launchpad/4039/IINFO.HTM>  
<http://www.geocities.com/CapeCanaveral/Launchpad/4039/POCFLEX.ZIP>  
<http://www.geocities.com/ResearchTriangle/Lab/9339/>  
<http://www.geocities.com/SiliconValley/Network/8916/4levelm.gif>

In general, "with respect to" means where to put the black lead of the voltmeter. So if you were to put the red lead at A and the black lead at G (ground), the voltmeter would read +9V.

Also per Figure 1, you can string a couple of "wall warts" together for an easy +/- power supply. For many of you, this might be the simplest and most effective approach. Radio Shack's "wall warts" tend to be expensive, but you can get them for next to nothing on the surplus market. Hosfelt Electronics is a major supplier of low cost dc adapters: <http://www.hosfelt.com/index.htm> or (800) 524 - 6464.

Ground in the dual polarity supply goes to external circuit ground or common. The (+) output goes to all points in the circuit that need a (+) supply voltage, and the (-) output goes to all points that require a (-) supply.

### A Practical Dual Power Supply

Figure 2 is the schematic diagram of a practical dual-polarity "filtered" power supply. In some cases, this may be all that's needed for non-critical circuits. Figure 2 is your basic building block, even if it needs to be regulated, which we'll get into ahead.

Check Figure 2 for the Radio Shack part numbers. I didn't give part numbers for the fuse and fuseholder, LEDs, power cord, box, and switch. These are personal preference items frequently found in the junk box. You'll need a metal box, say about 5" wide by 3" high by 6" or so deep. It should be considerably larger than the transformer, which should be bolted to the case off in a rear cor-

ner, out of the way.

Drill a 3/8" hole in the rear; slip a rubber or vinyl grommet into the hole and pass the power cord into the hole. Tie a half-hitch knot on the inside so the cord can't pull out.

Hot-glue, super-glue, or epoxy the bridge rectifier to the floor of the box near the transformer with the leads pointing up. Drill holes in the front panel for the light emitting diodes (LEDs), and holes in either the front or rear panel for the switch and fuseholder. Install these items and secure them in the holes. Hot-glue or epoxy will secure the LEDs in the absence of mounting hardware.

Wire up the primary side of the power transformer, T1, per Figure 2. Observe all safety precautions and be sure the power cord isn't plugged in. Use heat-shrink tubing to cover all solder joints and exposed 110-Vac contacts. You can use hot glue or silicone rubber to coat switch and fuseholder lugs, if need be. The idea is to make it impossible to get shocked, even with your grubby mitts in the box when it's plugged in. A shock from 110-Vac can be lethal!

Solder the center tap lead from the transformer secondary to the circuit ground output lead. Solder the other two secondary leads to the "ac" pins of the bridge rectifier (which lead goes to which ac pin doesn't matter.)

Solder the (+) lead of C1 to the (+) lug of

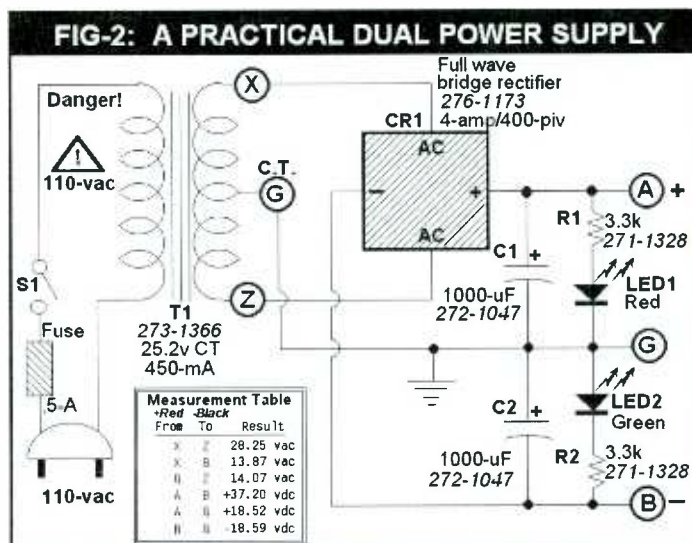



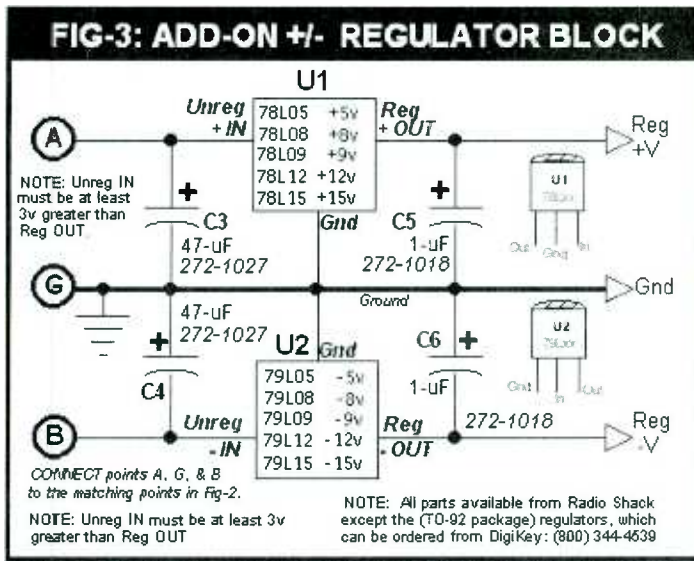

the bridge rectifier. Solder the (-) lead of C2 to the (-) lug of the bridge rectifier. Solder the remaining leads of C1 and C2 together, and then to the ground output lead. Do NOT ground any part of the power supply to the metal box, except a three-wire power cord where the green wire must be bolted to the chassis.

Wire up R1, R2, and the LEDs per Figure 2. Radio Shack's #274-662 make great output terminals. You'll need two pair. The common ground should feed both black terminals, while the (+) output feeds one red terminal and the (-) output feeds the other red terminal. Triple check all your work.

When you're sure everything's perfect, connect a voltmeter to Points A and B; plug in the ac power cord, and turn S1 on. The voltmeter should indicate about 37V dc. Refer to the Measurement Table inset in Figure 2 to confirm that other voltages are close.

#### What To Do With This Power Supply?

Maybe nothing. Look at the measurements in Figure 2.  $\pm 18v$  isn't very useful. However, the more current drawn from this power supply, the more the voltage drops. At the transformer rating of 450-mA, the output DC is

roughly  $\pm 12v$ . The output will fluctuate, depending on the load, so you really can't be sure of a given output. Let's fix it now!

#### Regulating Your Power Supply

Regulators produce constant specified outputs over a range of current demands. Popular regulated supply voltages include  $\pm 5v$ ,  $\pm 8v$ ,  $\pm 9v$ ,  $\pm 12v$ , and  $\pm 15v$ . You can add one or more for very little extra cost! Figure 3 is the schematic diagram of a cheap and easy dual polarity regulator circuit. Figure 4 shows how to build it on a piece of perfboard. One can be cranked out in minutes, and you can use as many as you like for multiple regulated outputs.

If you want more than one regulated voltage, then build a second and subsequent boards exactly like Figures 3 and 4, except use a different regulator for each desired output. Multiple boards should be "stacked" with parallel inputs from Points A, G, and B on the filtered power supply in Figure 2. See Figure 5.

I won't task you with theory here, but you should learn about three-terminal regulators. These cheap little transistor-looking devices

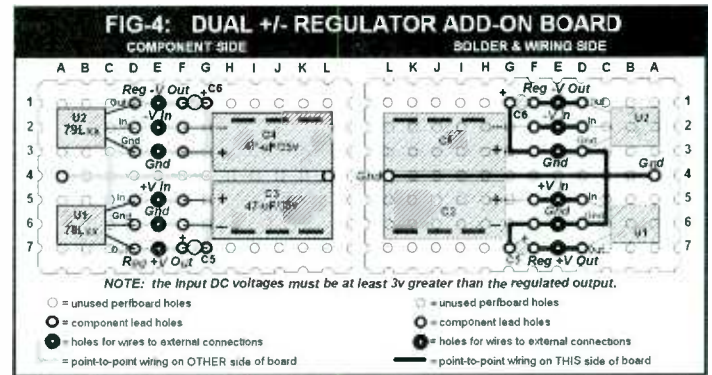

regulated output. For instance, a 12V regulated output requires a minimum 15V input to avoid "dropout." More is fine, up to about 35V or so.

Secondly, there is the matter of heatsinking (cooling). Larger TO-220 three-terminal regulators are designed to mount to a chassis or heatsink to dissipate heat. Smaller TO-92 "low power" regulators don't need heatsinks.

Lastly, you need to know about the numbering system for three-terminal regulators. The prefix "78" means a positive (+) voltage regulator, whereas "79" means a negative (-) voltage regulator. The last two numbers indicate the regulated voltage: 7805 is a +5V regulator and 79L12 is a -12V regulator. Four-digit numbers like 7805 and 79L12 imply the larger TO-220 package, good for over 1-amp of output current with proper heatsinking. Low power types, like 78L05 and 79L12 are good for up to 100-mA of output current. We will use the smaller type in this month's project. They're cheap at less than a buck apiece.

#### In Closing

Next month's exciting project is known to work on as low as  $\pm 5V$ , but  $\pm 12V$  is ideal. Anything over 18V will blow up the circuit, and anything over 13V might not be healthy for the computer. If you want the easiest way out and still be ready, Figure 1 works fine. If you choose "wall warts," a pair of 9V dc adapters is ideal. 12V adapters are out because their output at the low current required by our circuit (16-mA) is 15V or more. A pair of 9V batteries or a pair of 6V-9V "wall warts" work fine; regulators not needed. Just be ready, because we're going to have some fun!

Support for this and all my columns is freely available by e-mail. If you're not computerized, please include an SASE with postal requests.

E-mail: [bcheek@cts.com](mailto:bcheek@cts.com)  
WWW: <http://ourworld.compuserve.com/homepages/bcheek>  
FAX: (619) 578-9247 anytime  
Postal: PO Box 262478, San Diego, CA 92196-2478

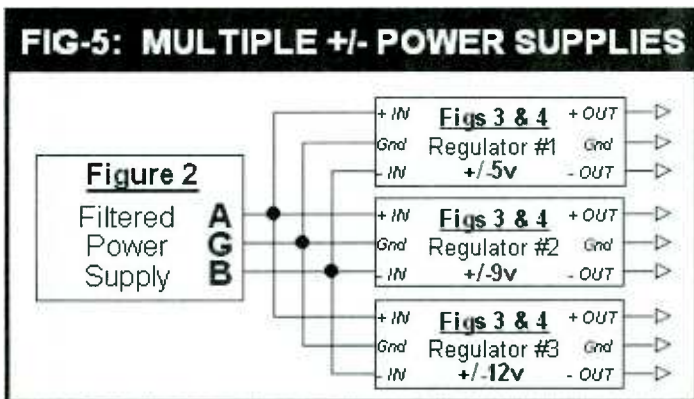

accept unregulated dc inputs and put out rock-solid dc at precise levels. Outputs are fairly immune to variations of input voltage and current and variations of output current. There are important things to know about three-terminal regulators. The input voltage must be a minimum of 3 volts greater than the designed

## Just What Does an Antenna Do?

**T**he theme of this month's issue of *Monitoring Times* is antennas, so let's consider just what an antenna is, and some of the things an antenna can do.

A generally acceptable definition of an antenna is that it is a device for transmitting or receiving radio waves. The "device" referred to usually consists of one or more conductors arranged to make transmitting or receiving of the radio waves happen as the operator wants them to happen. That is, we may design an antenna with a particular configuration, and with particular dimensions, such that the antenna will do more than simply transmit or receive radio waves. Let's see what some of these things are.

### ■ Some things an antenna can do

**Antennas can tune:** One thing we can do with an antenna is tune it to the frequency of the signal we want to receive or transmit.

That's right, for most antenna designs, an antenna acts as a tuned circuit. For instance a conductor cut to be one-half wavelength long at a particular frequency will actually be tuned to that frequency. This conductor will give a greater response to signals of that frequency than to signals at frequencies to which it is not tuned. In addition, this tuning function can help reject unwanted signals and thus avoid overload and intermod problems. So, although any random length of wire can serve as an antenna, one tuned to (reso-

nant) at the frequency of operation can sometimes give improved reception.

By the way, old timers knew and used tuned antennas to determine the length of the waves they transmitted or received with their spark-coil transmitters and coherer receivers. In the earliest days of wireless the antenna was actually the only tuned circuit in the entire system!

**Antennas can focus:** Another thing which an antenna can do for us is to focus its responsiveness in the direction of the station which we want to receive, or to which we want to transmit. Antennas which do this possess what we call "directivity." Antennas of this sort are often called "beam" antennas because the more directive ones tend to focus their signals into a beam somewhat like the beam from a car's headlight.

**Antennas can "amplify":** Antennas can also seem to "amplify" signals which they receive. That is, an antenna with a high level of what we call "gain" will give a greater output of signal (in a specific direction or directions) as compared to an antenna with less gain.

You might think that high-gain, high-directivity antennas are the most desirable, but this is not always the case. Sometimes we want to be able to hear signals which arrive from any direction. For this a "nondirectional" antenna, such as the quarterwave groundplane

is very desirable. The quarterwave groundplane antenna is relatively low in gain; however, it is quite possible to have higher gain in a nondirectional antenna (for example the coaxial, collinear groundplane).

But higher gain usually comes at the cost of increased price and complexity of the antenna, and the lower-gain quarterwave has gain entirely sufficient for most applications. And, on the shortwave bands where received-noise level often determines the quality of signal reception, increased gain is often of no particular value. So sometimes gain and directivity are desirable, sometimes other factors are more important.

**Antennas can determine how far away we can communicate:** Most of us already know that mounting a VHF-UHF, or microwave antenna higher will often lead to being able to communicating over a greater distance. This is because raising an antenna will increase the line-of-sight path between that antenna and the antennas with which it is to communicate.

On the other hand, consider the MF and HF bands where skywave communications is involved. Here the vertical angle at which the antenna best receives its signals, or best launches its signals, determines the vertical angle at which the signal contacts the ionosphere. This angle determines how far away from its transmitting antenna the skywave signal will return to earth. Antennas favoring

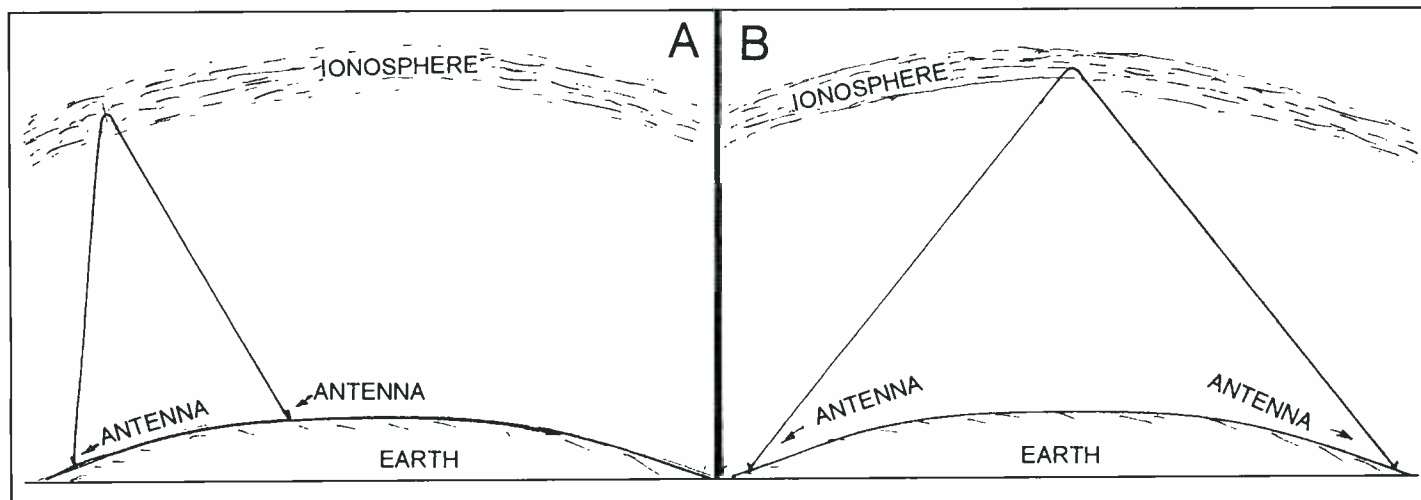

**FIG. 1.** The vertical angle favored by an antenna's response helps determine whether shorter (A), or longer distances (B) are covered by the communication path utilized.



low vertical-angles provide good support for long-distance (DX) skywave communications. Those favoring higher-angle vertical signals support shorter distance communications better (see fig. 1).

**And so:** ... antennas usually are not simply just a wire in the sky. They have several jobs to do, and, with proper design, they often do those jobs quite well.

■ **Where's the Hum?**

What has become of the mysterious hum that was recently so widely heard around the globe? The hum was reported to annoy and irritate persons in spots as disparate in location as California, New Mexico, Maine, Montana, and Scotland. Some describe the sound of the hum as something like a truck idling in the distance, others describe it as a low-pitched hum that is so loud as to be quite disturbing.

*MT* reader Bob Burnett, who reports regularly hearing the hum, describes its sound as "... like a 60-cycle hum,... buzz on a failing phosphorescent light ballast.. ." *MT* reader Norman Lynagh sent in a newspaper article from Scotland reporting about a woman kept

awake by the hum, saying that it sounded like the running of a pump or a bus. Government scientists there were reported as interviewing people and setting up equipment to study the hum.

Although there have been no definitive findings, there have been various suggestions as to the hum's origin. These range from its actually being a truck or pump running in the distance to energy from outer space, or sonic or electromagnetic waves following the conductivity of the earth. The reports of its frequency estimated as 60-Hz brings to mind Tesla's work which used the earth as a transmission medium for electrical power distribution.

Although some writers have considered the hum nothing more than a hoax, the consistency of claims concerning it has reportedly initiated serious scientific investigation by governmental agencies in both this country and abroad. If the hum turns out to be due to electromagnetic wave action, then we radio monitoring enthusiasts could possibly think of it as a radio wave in the "basement" of the radio frequency spectrum. If any readers have any new information on this subject I'd be pleased to hear about it.

◉ **RADIO RIDDLES** ◉

■ **Last Month:**

When we reviewed the MFJ 259B SWR analyzer I said, "One of the things that the 259B helps you check is "Q." What is this, and why do we care — or do we? If we don't, should we?"

Well "Q" can be thought of as standing for "quality" in the operation of a tuned circuit. When the Q of a tuned circuit is high then that the circuit is more selective, and when the Q is low the circuit is less selective. Sometimes we want high Q to tune more selectivity, and sometimes we want lower Q to allow more broad tuning. So, yes, we should and do care.

■ **This Month:**

Antennas have been called by various names including "skywires," "antlers," "signal grabbers," and "wings." Heinrich Hertz called them "conductors." The British often use a different term for "antenna." What is that term? What is its origin?

You'll find an answer for this month's riddle, and much more, in next month's issue of *Monitoring Times*. Til then Peace, DX, 73

**GROVE FCC MASTER FILE DATABASE ON CD-ROM!**

*Version 6.2*

Imagine owning all 3.4 million records on the FCC master file database--up to 185 GHz (185,000 MHz!)--all compressed into one powerful CD-ROM! That's right--police, security patrols, fire, emergency, disaster relief, press, business, industry, railroads, airports, buses, taxis, basic broadcast, conservation, coastal marine, power, utility, experimental, and more!

And it's easy to use: Arrange the fields on the screen in the order of your choice: frequency, licensee, callsign, city, county, state, service, class, mode, latitude and longitude, and power.

Start your own custom database, using the powerful Grove engine, with flexible editing capabilities and even a comments field for your personalized notes.

Search any area of the U.S. and possessions, or even a radius from your central location! Refresh the database from the FCC Web site free!

\*\*For Windows 95 and 98 only\*\*

ORDER FCC98-CD

**Only \$39<sup>95</sup>**

Please add \$5.95 US Priority Mail or UPS shipping

Because software is easily copied, it is not refundable. Defective copies will be replaced at no charge

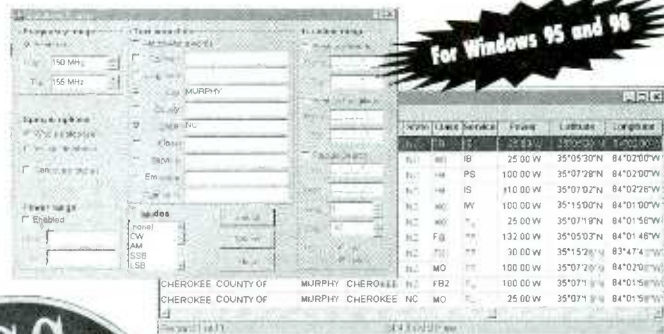

**GROVE**

Grove Enterprises, Inc.

7540 Highway 64 West

Brasstown, N.C. 28902

(800) 438-8155 US & Can.

(828) 837-9200

Fax (828) 837-2216

e-mail: [order@grove-ent.com](mailto:order@grove-ent.com)

World Wide Web: [www.grove-ent.com](http://www.grove-ent.com)

## W6SAI HF Antenna Handbook

**S**peak of antenna books to most hams and chances are good the call W6SAI will come up, as Bill Orr has produced more accurate published information about antennas than any other single individual. Bill has been around ham radio since the early 30s, and is well known for his *Editors and Engineers Radio Handbook*. In addition he has produced handbooks on Yagi beams, quads, vertical, and wire antennas, and has written numerous magazine articles on the same subjects.

His latest effort, *W6SAI HF Antenna Handbook*, is a compilation of easy-to-build, effective antennas. Bill has researched most of the popular antennas and improved many of them. The first two chapters are devoted to theory and feedlines; especially interesting is a section in chapter two dealing with hardware and accessories.

Chapter three deals mainly with multiband antennas like the G5RV, Windom, or off-center-fed (OCF) and simple antennas that perform well for DXing. A wide variety of multiband dipole antennas and various methods of feeding and supporting them follows in chapter four. Chapter five is devoted to transmitting and receiving loop antennas, including the cubical quad and other high gain models. The sixth chapter is devoted to 160 meter antennas with something for almost everyone. Chapter seven describes numerous transmatchs and matching devices.

In recent years a number of antenna analysis programs for the computer have become available and can provide the user with a lot of information about a proposed antenna. Unfortunately, many of these programs are difficult to learn and can confuse the beginner. Bill's eighth chapter discusses these programs and reduces much of the confusion.

Chapter nine details many inexpensive beam antennas the amateur can build and discusses the two-element versus three-element yagi. Also included is a practical cubical quad for 20, 15 and 10 meters. Chapter ten explains antenna instrumentation and how to use the various instruments available to the average ham.

If you have any interest at all in building antennas, this book is for you. I highly recommend the *W6SAI HF Antenna Handbook*. It is available from CQ Communications Inc., 25 New Bridge Rd., Hicksville, NY 11801 for \$19.95 plus \$4 shipping.

### ■ Out of the Past

I have *QST Magazine* on CD dating from 1915 to present days, and I spend a lot of time reading the older issues of the magazine. One article in particular I think might be of interest to those of you who like to experiment with antennas. Published in the August 1940 issue, the article is entitled "The fixed rotary beam antenna," by W2DKJ, Arthur Lynch.

The author describes a method of feeding and switching three "Pitchfork" antennas. While the Pitchfork is only 7/16th of a wavelength, it looks a great deal like an end fed W8JK. W2DKJ has erected his antenna as a vertical (see fig one).

FIG. 1

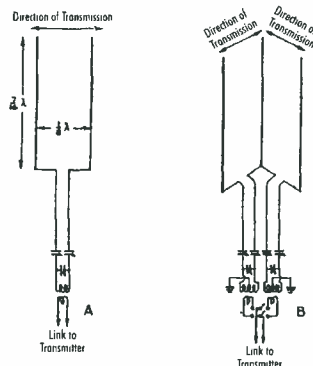

Being vertical, the antenna should produce a very low take-off angle which is ideal for DXing. Bidirectional gain of this antenna will be 3 to 4 dB. The antenna can be built from wire and wood and suspended from a tree or tower. Use 450 ohm ladder line to the transmatch.

If you try a Pitchfork, please drop me a note and let me know what kind of results you have.

### ■ Checkers, Anyone?

In the same issue of *QST*, Amos Utterback, W9FB, describes a method of playing checkers over the air. For several years I played chess with a group of friends over the air but never thought of checkers. Since checkers is a more widely played game, I thought this might prove interesting.

First of all, prepare a checkers board as in fig. 2. Use the scheme shown, and you can use either numbers or letters while playing. When playing, place the board so that the double corners (i.e., 1/A -5/E) is at the upper left and 28/BB - 32/FF is on the lower right.

	1 A		2 B		3 C		4 D
5 E		6 F		7 G		8 H	
	9 I		10 J		11 K		12 L
13 M		14 N		15 O		16 P	
	17 Q		18 R		19 S		20 T
21 U		22 V		23 W		24 X	
	25 Y		26 Z		27 AA		28 BB
29 CC		30 DD		31 EE		32 FF	

FIG. 2

Be sure to make moves simultaneously; if a player makes the move 6 to 10 (or f to j), be sure both players make that move on their board. It is a good idea to repeat moves to each other to be certain no errors are made. Also before starting play, be sure to tell your opponent if your pieces are in the 1 to 12 (a to l) sector or 21 to 32 (u to ff) sector.

If this catches on, it might be a good idea to set up frequencies where one can find a game. For example, I would suggest 3710 kHz on 80 meters CW; 28,355 kHz on 10 meters SSB; and 144.56 MHz FM on two meters. Of course, there may be other activities on these frequencies, so make adjustments accordingly.

### ■ Band Conditions

I am sure that anyone who has been active this past winter is aware of the superb conditions we have had on all HF bands. Ten and twelve meters have been producing DX from all over the globe at this location.

This is the time of year when conditions peak on the lower bands for working into the antipodes (the point on the globe opposite your location and therefore the furthest away); early morning and early evening will be the best times on 160, 80 and 40 meters.

### ■ VHF AM

Amplitude modulation has been catching on. I have noted considerable AM activity on both bands. This is a great idea, as simple rigs can be built or purchased inexpensively for these bands. So if you've been AMing, keep it up.

Last month I listed two e-mail addresses; the best to use is [n3ik@hotmail.com](mailto:n3ik@hotmail.com), the other address has changed to [n3ik@planetdirect.com](mailto:n3ik@planetdirect.com). I do check both mail boxes several times weekly. 73 one and all de Ike N3IK



# Motorola's TalkAbout® Distance GMRS Radio

**A**nyone who gets into using Family Radio Service handi-talkie will quickly discover that, despite their other admirable characteristics, they are limited in range. The manufacturers say "up to two miles," and that can be achieved under ideal conditions.

But conditions are seldom ideal, and sometimes the reliable range of FRS radios is 1/2 mile to a mile. In a nutshell, that means FRS may not be the best choice for communicating between people who are likely to get separated by greater distances.

So when I saw "TalkAbout Distance" radios mentioned on Motorola's website, I thought, "Great! They've solved the problem." But there's a trick here: while Motorola has spent considerable money building up the TalkAbout brand for FRS, TalkAbout Distance units are *NOT* FRS radios.

Nope, these are type-accepted for the General Mobile Radio Service. You may not legally operate these radios without first applying for, paying for, and getting a GMRS license.

This crucial fact is mentioned in small type on an end flap of the box and on page two of the Owner's Manual, but strangely, it is not mentioned in a section of the manual entitled "Before You Can Talk" on page eight of the manual. Neither is a copy of the license application or the GMRS rules and regulations included in the box!

The TalkAbout Distance can operate on 10 channels:

- 1      462.5625
- 2      462.5875
- 3      462.6125
- 4      462.6375
- 5      462.6625
- 6      462.6875
- 7      462.7125

plus,

- A.     462.5750
- B.     462.6250
- C.     462.6750

Interestingly, this 1-7 and A-C setup are the actual channel designations that are used on the TalkAbout Distance unit. The first seven are channels that are shared between FRS and GMRS. People with FRS radios



*The Motorola TalkAbout Distance offers sparkling performance marred by tedious programming and no information display. But don't forget that GMRS license!*

don't need a license to use them. Folks with GMRS radios do. Weird, eh?

The last three channels are GMRS frequencies, and they are actually the output frequencies for three GMRS repeater pairs. The General Mobile Radio Service allows the use of repeaters to extend range, but *Motorola's TalkAbout Distance radios are only capable of simplex operation and cannot be used to access GMRS repeaters.*

### ■ Using the TalkAbout Distance

The TalkAbout Distance handi-talkie is simplicity itself. On the front panel is a grill for the speaker and a microphone. On the left side, a push-to-talk button and a monitor button for disabling the auto. On the right side, a flap can be lifted to plug in a battery charger or various accessories such as speaker-microphones.

On each side, there is a small clip that can be moved to release a section of the front panel for access to the batteries. On the back panel, there is a large removable belt clip.

On top of the radio, there is a screw-on rubber ducky antenna, an on/off volume control, and a knob that can be used to select any of the TalkAbout Distance's ten operating frequencies. An 11th position on the channel selector, designated "S," puts the radio into a mode that scans all ten channels. That's it.

Now, since you folks who read this column are usually a pretty sharp bunch, you may have already noticed what's missing. That's right: there's no display of any kind. And that's where the rub comes in. If the radio is in scanning mode, you can't tell what channel is being received.

In addition, since the TalkAbout Distance can be programmed for the use of what Motorola calls "Interference Eliminator Codes," (really Continuous Tone Coded Squelch System codes), there is no ready way to determine what, if any, code has been activated.

To activate any of the 38 Interference Eliminator Codes requires turning the radio on while holding down the push to talk button. A female robo-voice then announces the current code setting, for example, "Code Off." Press the push to talk button, and the TalkAbout Distance scrolls, through audio announcement, through the available codes: "one ... two ... three ..." and so forth. When you get to the code you want, release the push to talk button, and then press the monitor button to select and save the code setting. If you miss the code you wanted, you have to scroll through the entire list again (one ... two ... three ...).

Once you have the desired code, you can then press the push to talk button to toggle between bandwidth settings for FRS and GMRS (12.5 kHz and 25 kHz, respectively). I found programming this radio to be tedious and borderline "user hostile."

Fortunately, the performance of the TalkAbout Distance sparkles. Two watts give this radio far more range than any FRS unit I have ever tested. Motorola claims up to five miles, and that wouldn't surprise me under ideal conditions. In addition, send and receive audio are crisp and clear. I walked over my standard test range in a drizzling rain and can also affirm that these radios are at least "weather resistant."

The TalkAbout Distance comes standard with rechargeable batteries and a wall-wart charger. Suggested retail price is \$259.99. A second model (not tested), the TalkAbout Distance DPS, offers the choice of rechargeable batteries or alkalines for \$279.99. For more information, call 1-800-353-2729 or visit [www.motorola.com/talkabout/talkabout](http://www.motorola.com/talkabout/talkabout).

# Xtremely Useful Paperless Logging

A few years back we found DXtreme Software's Short Wave Reception Log, SWRL. It was an easy to use alternative to a paper log book and didn't cost your left arm. Well, since that time the people at DXtreme have been busy adding new features. The latest version, SWRLgold V3.0, is quite a bit more capable than the early version. Let's take a look at this new version and see if it lives up to its fine lineage.

In order to include all the features, the program's minimum requirements are: a Windows 95/98 environment, a Pentium 100, 16 Meg of RAM, SVGA (800x600) and a minimum of 5 MB of hard disk space. I remember a few years ago when the hottest flight simulators didn't have such high hardware requirements. But today, if any program is going to effectively utilize Windows 95/98 these requirements are modest.

## ■ Goodbye Paper?

The program, which comes on four HD 3.5 inch disks, installed in under six minutes on my Pentium 233 (HP Pavilion 3266, running Windows 95). I used the Add New Hardware menu in the Control Panel for installations. The SWRL icon, which then appears in the Programs menu, is used to start the program displaying the Reception Log.

Figure One shows the "business" screen of SWRLgold V3.0, the Reception Log. Here the user adds station intercepts to the

**FIGURE 1 - Reception Log Screen: Where it all happens**

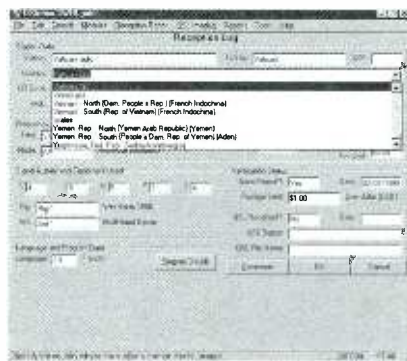
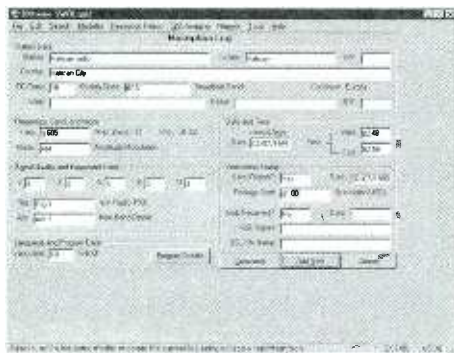

**FIGURE 2 - Pull-down Counties List**

log, or searches the existing database for previous reception reports. Data entry is straightforward by filling in the Station field box, once the Add New box at the lower right is clicked. Notice how, once a frequency is entered, the wavelength is automatically displayed to its right. A nice touch. A new feature of V3.0 is that the frequency range is no longer limited to shortwave. You can now log stations from VLF to UHF. A sign of the times is the inclusion of Web and Email address fields; acknowledging the co-existence and melding of two different communications media.

## ■ The Command Modules

The Modules menu is important to the convenient operation of SWRLgold. Many of the fields, such as Country, once clicked, display a "pull-down" down arrow on the right. See Figure 2. This indicates that you can choose the required data from an existing list. For example, Vatican City was already in the countries list. Therefore all I did was click on it. The source of these pull-down menus are the modules.

Via the Modules menu, items can be edited, added or deleted from these pull-down lists. Figure 3 shows us the "countries module," where other data (continent and CQ zone) are carried along with each

country name; these appear in the pertinent reports and screens.

Now, new countries don't appear that often. However, if you are lucky enough to have more than one receiver, or antenna, this list feature is very useful. Enter all of your receivers and antennae in their respective modules. Then a click on the down arrow is all that is ever needed to detail your exact listening station at the time of the intercept. This is important for your log maintenance, as well as for the slick, SWRL-generated QSL request.

A number of the other modules, such as the abbreviations list, are quite useful. The UDF field (user defined field) is a freebie field where you can decide to track a new reception variable; for example, the sun spot number.

## ■ The Many Faces of a Computer Log

A big difference between written logs and SWRL V3.0 is how the data can be recalled. Clearly, for a written log, the sequence that you wrote the data into the log is the only way you can recall, or look up stations. For example, most logs are "keyed" off the date/time of the intercept. The oldest intercept is in the beginning of the log, while the most recent is at the end.

Using SWRL V3.0 reports can be generated in many different ways using combinations of fields. For example, a list of all the European broadcast stations monitored, listed by frequency, can be viewed and printed. Alternatively, a report can be generated showing all the European stations listed by time of reception. Or all the French language stations ... I think you get the flexibility of this program's report feature. The Reports menu give the user a whole host of report variations.

## ■ Using SWRLgold V3.0

All the help you could ask for is available in the program. One Help method



**FIGURE 3 - Countries Module Screen**



comes in the form of detailed "what is this" notes which appear with a right mouse click over the object in question. The Help menu is extensive and dynamically accessed through click-on procedural steps. Within fifteen minutes most people can feel comfortable and confident. From there it's just a matter of building your personal database.

The number and storage capability of comments and program content fields has been expanded. Now you don't have to write in cryptic abbreviations to fit your program details in a small box. Finally, the QSL Imaging allows you to add a scanned image of the coveted received QSL. Of course, for this you need a photo/flatbed image scanner.

#### ■ Just in Case

Until you generate a report, all your data is at the mercy of the reliability your computer hardware. This is the case with any program. So don't forget to back up your files often and on different removable media (floppy, zip, etc) ... just in case.

Speaking of "just in case," after extensively exercising the program, I had only one "interesting" situation occur. When you minimize SWRLgold to the Windows 95 or Windows 98 taskbar, be sure to Restore the program before you Close it. If you inadvertently close SWRLgold while it is in the taskbar, the next time you start it, SWRLgold will appear in the taskbar only and you will not be able to maximize it or use it.

Fortunately, the people at DXtreme have already come up with an easy fix. If you accidentally close SWRLgold while it is in the taskbar, perform the following steps:

1. Start the Notepad applet of Windows 95 or 98.
2. On the File menu, click Open. The Open dialog box appears.
3. In the Files of type list box, select All Files (\*).
4. In the Look in list box and folder display area, navigate to the drive and folder where you installed SWRLgold. If you accepted the default location when you installed SWRLgold, navigate to the C:\DXtremeSWRLgold folder.

5. Locate and single-click the RLWIND.DAT file and then click the Open button. When the file opens, you will see a single line that contains four numbers; for example: 36000,36000,1920,348
6. Change these numbers to the following: 0,0,9500,6700 Be sure to enter the numbers exactly as shown; no spaces between numbers or commas.
7. On the File menu, click Save. Then close the Notepad applet. When you start SWRLgold, it will appear at the top, left of your screen. Adjust the size of the Reception Log window.

DXtreme Software has posted this procedure on their web page and will fix this problem in a later version of DXtreme SWRLgold. For now, just remember to NEVER close the program when it is minimized on the taskbar. With this one exception, SWRL V3.0 was very well behaved and performed as advertised. SWRL V3.0 is the result of a professional effort, and it shows.

#### ■ Rapped Up

I think that SWRLgold V3.0 will make you throw away your paper log forever. It's available for \$39.95 (\$41.95 outside of N. America). For those who purchased a previous SWRL version, the price is \$13.00. Check out their Web site: [www.dxtreme.com/dxtreme](http://www.dxtreme.com/dxtreme). DXtreme Software, 26 Langholm Drive, Nashua, NH 03062.

Next time we'll fire up the crystal ball and try to see what radio hardware (or is it software!?) will look like twenty years hence. Surely, you can hold on a month to glimpse the next few decades. The future awaits.

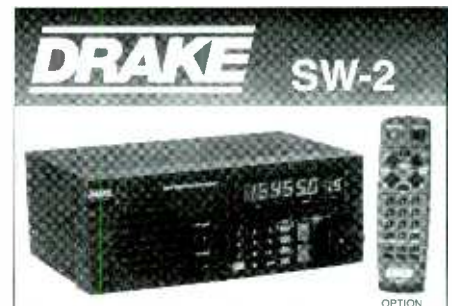

The Drake SW-2 provide continuous coverage from 100 to 30000 kHz in AM, LSB and USB modes. Tuning is easy via manual knob, up-down buttons or 100 memories. The sideband selectable synchronous tuning stabilizes fading signals. Other refinements include: RF gain, tuning bar graphs, huge 100 Hz LED readout, keypad and dimmer. The optional remote (shown) lets you operate this radio from across the room (Order #1589 \$48.95). All Drake receivers are proudly made in Ohio, U.S.A. and feature a one year limited warranty. Regular Price \$489.95 Sale \$399.99 (+\$7 UPS)

The Drake SW-1 broadcast receiver also covers 100 to 30000 kHz, but in AM mode only. Features include: 1 kHz LED readout, keypad, RF Gain and 32 memories. Both models operate from 12 VDC or via the supplied AC adapter. A great starter radio! Regular Price \$249.95 Sale \$199.99 (+\$7 UPS)



**Universal Radio**  
6830 Americana Pkwy.  
Reynoldsburg, OH 43068  
◆ Orders: 800 431-3939  
◆ Info: 614 866-4267  
◆ FAX: 614 866-2339  
[www.universal-radio.com](http://www.universal-radio.com)

Quality Communications Equipment Since 1942

### HF-VHF-UHF Receiver Multicouplers & Preamplifiers

Are you using several HF radios or VHF/UHF scanners at your monitoring site??  
...consider including a multicoupler or a preamplifier to your system.

### SWL/Scanning - Radio Surveillance - News Rooms

Both our Passive and Active Multicouplers are commercial grade specially designed for demanding monitoring applications with multiple radios. Our 2 and 4 port couplers are 50 ohms units with better than 24 dB of port-to-port isolation. Active couplers features wide-band Low-Noise distribution amplifiers with High-Pass/Low-Pass filtered inputs, BNC connectors standard.

Please visit our web site: <http://www.stridsberg.com> for data sheet, application and ordering information.



**STRIDSBERG ENGINEERING, INC.**  
P.O. Box 5040  
Shreveport, LA 71135-5040, USA.

Phone: (318) 861-0660  
Fax: (318) 861-7068

# Emergency Radio: Info-Mate Model No. 837

It was a moment of inspiration for British inventor Trevor Baylis: to create a radio powered by a windup generator—a receiver even the poorest African villager could afford to enjoy out in the bush, away from electricity. Since then, his hugely successful BayGen “Freeplay” radios, blessed publicly by no less than Nelson Mandela, have been produced by disabled and other African workers at BayGen Power Group’s plant in Cape Town.

Initial batches had generator springs of dubious quality, and radio reception was marginal, especially for the price. But things improved, and the combination of an innovative low-tech idea and socially conscious manufacturing made the Freeplay a “must run” story in newsrooms worldwide. The rest you know, and BayGen—now called Freeplay Energy (800/946-3234 in the United States)—is off and running with a growing line of alternative-power electronic products.

### ■ When the going gets tough, the tough get cranking

While the appeal of Freeplay’s strategy to the socially concerned is obvious and real, its radios have also become “must have” items for survivalists, militia folks and others traditionally identified with the political right and populism. Yet another market in North America has been those living in areas prone to hurricanes, tornados, earthquakes, or potential civil unrest or terrorist attack. Legions of American gadget freaks have also helped swell the ranks of Freeplay owners.

The Y2K bug has probably been the most ballyhooed story since the Oval Office Romp, helping lead some concerned folks to become Instant Mormons by stocking up on emergency supplies of all sorts. This has only served to heighten the already-existing demand for emergency radios, particularly models which receive shortwave. After all, shortwave isn’t like local stations and the Internet. It is reliable, long haul, multinational and nearly impossible to censor, making it the ultimate vehicle for credible news in times of crisis.

### ■ World band radio, antidote to danger

During the initial revolutionary takeovers in Beirut and Tehran, various Western offi-



cials managed to escape thanks in part to information gleaned from BBC, VOA, Kol Israel and other world band newscasts. One key official, apparently the most sought-after by Islamic militias, called to thank me after his return, insisting that *Passport to World Band Radio* literally saved his life. His on-the-spot experience—darting through alleyways from safehouse to safehouse based on news reports from afar—makes any Tom Clancy novel pale by comparison.

### ■ Info-Mate’s high card: multiple power sources

Of course, nothing so juicy as the emergency radio market can go on indefinitely before competition appears, which it now has in the form of the Info-Mate 837 World Band Radio. Like the Freeplay, the 837 uses a hand-cranked generator to generate power. But unlike the shortwave version of the Freeplay, there is no windup spring; rather, the Info-Mate’s inboard generator is used to charge NiCd cells.

But, as pitchmen put it on late-night TV, there’s much, much more: a solar panel atop the set, a “wall wart” AC adaptor; and, oh yes, a plug for vehicle cigarette lighters—any of these can be used to charge the cells. A low-power battery indicator tips you off to get cranking, but it takes a disconcerting amount of wrist wrestling to charge those thirsty little cells: five tiring, boring minutes to get only an hour’s worth of playtime.

All this hand jive is fine and well if you’re holed up in a shelter fearing for your life, but it can get to be a first-class pain in the cuticles once the novelty wears thin. Soon, you may find yourself musing on the virtues of smoke signals or semaphores for electricity-free communication.

The 837’s solar option is much handier. The manufacturer claims that three hours of sunlight will provide enough juice for four to six hours of listening, and that on full charge the cells will provide roughly seven hours of reception. Of course, there is sunshine and there is sunshine, and our tests suggest that these are best-conditions numbers—high noon in Arizona, for example.

The four everyday “AA” rechargeable cells are nominally good for five years, and being removable they are easily replaced. The Freeplay, sans cells, suffers from no such limitation; it runs for half an hour from a single 20-second winding.

Otherwise, there’s no more to the 837 than to the Freeplays: a carrying strap, tuning knob, volume control and earphone socket. Missing altogether is an auto-fade dial light, which would be mighty handy in the dark when there’s no juice. The telescopic antenna swivels and rotates, which aids in reception and helps assure the antenna won’t be broken off at the base.

The 837’s power concept is more flexible and generally handier than the simple crank-to-power approach of the Freeplay. It costs the same, too: \$99.95. The 837 is made in China, but includes Toshiba parts, and its solar cell is American-made.

The Freeplay, of course, is manufactured in South Africa. Two years back BayGen threatened to bolt to Brazil because of South Africa’s high tariff on imported electronic components, but this dispute was amicably resolved. Instead, within two-to-three years Freeplay Energy plans to add assembly plants in such disparate parts of the world as South America and India, according to Vaughan Wiles, president of Freeplay.





## ■ Broad coverage of radio spectrum

In addition to the more flexible power setup, the 837 receives VHF 59-165 MHz, which includes the Japanese FM band, the regular FM band, an air band, U.S. weather radio, and NTSC TV channels 2-6; also included is audio for NTSC TV channels 7-13. AM coverage goes all the way up to 1700 kHz, and shortwave reception is continuous from 4-24 MHz.

The Freeplay tunes much less of the radio spectrum. Units from current production cover AM 520-1700 kHz (earlier units stopped at 1600 kHz) and FM 87.5-108 MHz. Some Freeplay models don't cover shortwave, but of the two that do one, the FPR1-A, tunes from 3.3-12 MHz; whereas the other, the FPR1-B, goes from 5.8-18 MHz. For North Americans and Europeans, the latter version makes much more sense, especially as we are now in a period of rising sunspot activity.

The FPR1-A and FPR1-B are scheduled to be replaced by one or more shortwave models around autumn of 2000. These are expected to be smaller, lighter, more efficient and user-friendly. However, it is not yet known whether the manufacturer plans to upgrade performance with such fundamental features as digital and keypad tuning, presets, dual conversion, tighter selectivity and the like found on most of the dozens of radios tested in the 1999 *Passport to World Band Radio*.

## ■ Performance falls flat

While the Info-Mate 837 has several important advantages over the Freeplay, including relatively compact size, it isn't in the same league when it comes to performance. Mediocre as the Freeplay's reception is, it shines next to the 837 on virtually every count.

To begin with, the Freeplay has much more pleasant and powerful audio. Additionally, the 837's tuning is sticky, tricky and coarse—about as bad as we've ever encountered. FM reception is bottom-drawer, too, and AM fares little better, with desired stations awash in spurious howls. Shortwave comes up, well, short, with poor sensitivity, poor selectivity and unbelievably bad image rejection.

The Freeplay has audibly better overall performance. Neither it nor the 837 has acceptable frequency readout, though. Shortwave tuning is reduced to hunting-and-pecking by ear, the way it was done back when President Nixon was still in office.

## ■ Better idea: outboard charger for \$19.95

Surely somebody should be able to come up with a \$100-150 AM/FM/shortwave receiver with emergency power that does better than either the Freeplay or the Info-Mate 837. In the meantime, one solution would be a separate outboard windup generator or solar battery charger.

Fortunately, Sun-Mate, which manufactures the Info-Mate line and other solar products, produces just such a charger, Model #698, for only \$19.95. Of all the options for emergency radio powering, this probably makes the most sense for now. You buy the radio you want, then use the solar charger to power it along with anything else you might need which relies on battery power. Sun-Mate can be reached toll-free at (877) 786-6283, fax (818) 883-8171, [www.sun-mate.com](http://www.sun-mate.com), or 8223 Remmet Avenue, Canoga Park CA 91304.

Even more exciting is the Freeplay Standalone Generator currently being engineered. This advanced multivoltage windup device—probably cranked, but maybe with a yo-yo type pull string—is designed to be lightweight, small, efficient and user friendly. It is supposed to be able to provide enough power not just for radios, but also for such power-gobblers as laptop PCs and cellphones without requiring excessive cranking or pulling. No official date for introduction has been set, but given how these things usually unfold sometime in 2000 should be a reasonable estimate.

## Sony Introduces the Innovative ICF-SW07 Portable

By the time you read this, Sony will have introduced the compact-sized ICF-SW07. (Get it? Sam Sony's "double-u-oh-seven," as in James Bond's "double-oh-seven." Actually, the itty ICF-SW100S/E will always be the preferred spook radio, but the 'W07 comes close.) It is basically an enlarged and enhanced version of the popular ICF-SW100S/E "clamshell" pocket portable, right down to synchronous selectable sideband and a snazzy multi-zone clock.

Like the ICF-SW100S, it comes with an armful of accessories, including an AN-LP2 active loop antenna made especially for the 'SW07. This new antenna reportedly is electrically bandswitched by the 'SW07, and thus won't work with other receivers. These will continue to have to use the existing AN-

LPI—exact same thing, but with manual bandswitching.

Shortwave station schedules are stored on an inboard replaceable ROM. This provides the ready-to-go "smarts" for four dedicated buttons to scan for suitable channels of the BBC, VOA, Deutsche Welle and one other major station (RFI, Radio Nederland, Radio Japan, Radio Exterior de España or China Radio International, as you prefer). There is also a similarly performing fifth button you can self-program, along with ten conventional world band presets and another ten FM presets.

Because this is such an intriguing receiver, we are testing two samples exhaustively for several weeks in different parts of the world, and will report on our findings in *MT* as soon as the testing procedure is wrapped up.

Street price: probably less than \$450. After all, it's for Goldfinger, *n'est-ce pas?*

*This equipment review is performed independently by Lawrence Magne and his colleagues in accordance with the policies and procedures of International Broadcasting Services, Ltd. It is completely independent of the policies and procedures of Grove Enterprises, Inc., its advertisers and affiliated organizations.*

RADIO DATABASE INTERNATIONAL WHITE PAPER® reports contain virtually everything found during exhaustive tests of premium shortwave receivers and outdoor antennas. For a complete list, please send a self-addressed stamped envelope to RDI White Papers, Box 300M, Penn's Park PA 18943 USA; or go to [www.passport.com](http://www.passport.com).

### Software for the Shortwave Listener...

SWBC Schedules - Broadcast frequencies and programs, updated weekly+ \$35/year  
Smart Lowe Control 32 - NEW - Smart control for the Lowe HF-150 \$60/995  
Smart R8 Control - Smart control for the Drake R8/R8A/R8B \$25.00/\$40.00/\$60.00/995  
Smart Audio Control - Audio scope and spectrum analyzer for your PC \$25.00/\$35.00/995  
SWBC Interval Signals - Turn your PC into a virtual shortwave receiver \$5.00/\$30.00

*FineWare*

11252 Cardinal Drive • Remington, VA 22734-2032  
<http://www.crosslink.net/~mfine/>

## Icom IC-R2 Portable Scanner

In the world of portable scanners, size DOES matter. Regardless of how distracted I become, it's never quite possible to forget I'm carrying a Uniden BC3000XLT, an AOR AR8200, or any of their contemporaries. That's all changed with the new Icom IC-R2 portable scanner.

The new IC-R2 is tiny. It fits inside the palm of my hand and can share shirt pocket space with pens, cough drops, and other doodads. The 7-inch rubberized antenna, fitted with an SMA connector, is over twice as long as the radio. When loaded with batteries, the IC-R2 weighs merely 6.3 ounces versus the BC3000XLT's 14.2 ounces.

### ■ General Features

The IC-R2 is made in Japan. It tunes the spectrum from 495 kHz to almost 1310 MHz, which affords coverage of the AM/FM broadcast bands, television audio, shortwave, and VHF/UHF. Users may choose AM, NFM, and WFM reception modes and 10 selectable tuning step sizes, ranging from 5 to 100 kHz. Continuous Tone Controlled Squelch System (CTCSS) decoding and CTCSS search are built in, along with the ability to program duplex frequency offsets.

The IC-R2 does not require a special, high cost battery pack — a sore point with hobbyists. Instead, the radio uses two common AA batteries and the US version is furnished with Saft 700 mAh NiCd cells. You cannot recharge batteries while they are inside the radio. Icom includes a night-light-shaped wall charger, model BC-127A/D, which holds and charges two or four AA NiCd cells in 7 or 9 hours, respectively.

I get about 5-1/2 hours of scanning between charges. Battery life can be extended when not scanning or searching by enabling the power saver. In addition, an auto power off function is configurable to turn the radio off after 30, 60, 90, or 120 minutes since the last key press.

The IC-R2 contains a single, detent control knob, used for tuning and navigating through menus of options. A side mounted function key (FUNC) is used in tandem with the knob and other keys, but requires a bit too much pressure for comfort.

The volume is adjusted using up and down keys. The squelch can be opened fully, set in

an automatic mode or nine different thresholds by twisting the selector knob while pressing the side-mounted SQL key. While not nearly as handy as a simple squelch potentiometer, I found the squelch consistently well behaved across all frequencies and modes even at the lowest threshold.

A 1/8-inch three-conductor jack atop the radio is used for earphone or serial connection to a personal computer. Audio is sent to only one side of a pair of stereo headphones. When not in use, the jack is protected from dust by a captive rubber plug.

### ■ Memory and VFOs

There is no numeric keypad. The IC-R2 sports one variable frequency oscillator (VFO) and 400 channels, organized into eight banks of 50 channels each. Frequencies are entered into the VFO using a combination of the Band key and the top-mounted tuning knob.

To program a memory channel, you first tune the VFO to the right frequency and use menus to select other parameters. The IC-R2 can store the information in the next empty memory channel or you can choose a specific channel instead. Mode, tuning step size, and CTCSS code can be programmed for each memory channel. You can program a duplex frequency offset for listening on repeater inputs, too.

Like other Icom models, you can scan one memory bank at a time, not multiple banks.

The limit search lets you search for active signals between two frequency limits of your choosing. The little IC-R2 is big in this department — it provides 25 pairs of search limits! You can skip over frequencies during limit and VFO searches. Ordinary memory channels are used to store the locked out frequencies, so you can inspect them or set up the skip frequencies ahead of time.

There are three choices for when to continue scanning (or searching) in the presence of a signal: Resume, Pause, and Hold. A global rescan delay waits for the signal to drop and is programmable in six steps between 0 and 5 seconds. This is the type of scanning I use most often and appreciate being able to tailor the delay.

Instead of a rescan delay, you can choose

to pause the scan for 2 to 20 seconds and restart the scan after that interval even if the station is still transmitting. The Hold setting halts the scan the first time the IC-R2 detects a signal. At 9 channels/sec., my IC-R2 scans and searches about 50% faster than the IC-R10 I tested in March 1997 *MT*, and that's with CTCSS programmed into several channels.

The IC-R2 does not include an Auto Store search (a.k.a. auto memory write) as found in more expensive models.

### ■ How Does It Play?

I was pleasantly surprised that a radio as small as the IC-R2 produces good audio, both in amount and qual-

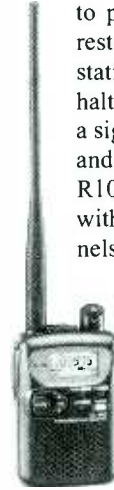

### MEASUREMENTS IC-R2 PORTABLE SCANNER S/N 01385

Frequency coverage (MHz):	0.495 - 1309.995, except 824 - 848.995 and 869 - 893.995
Step sizes (kHz):	5, 6.25, 10, 12.5, 15, 20, 25, 30, 50, 100
Modes:	AM, WFM, NFM
NFM Sensitivity:	see graph
AM Sensitivity (12 dB SINAD, 30% modulation):	1.4 $\mu$ V @ 0.5 MHz 1.7 $\mu$ V @ 1 MHz 1.0 $\mu$ V @ 5 MHz 0.8 $\mu$ V @ 10 MHz 0.8 $\mu$ V @ 20 MHz 0.7 $\mu$ V @ 30 MHz
FM modulation acceptance:	9.9 kHz
Audio output (measured at earphone jack):	69 mW @ 6.8% distortion 82 mW @ 17% distortion
Intermediate Frequencies (MHz):	266.7, 19.95, 0.45
Image rejection due to 1st IF:	95 dB @ 155 MHz 38 dB @ 868.9 MHz 74 dB @ 336.6 MHz
Practical memory scan speed:	9 channels/sec.
Search speed:	26 steps/sec.
Current consumption at 3 Vdc:	off - 0.09 mA manual - 106 mA scan - 109 mA full volume - 178 mA lamp - 10 mA additional
Battery saver:	after 5 sec. Manual mode.
Low battery warning:	at 2.2 Vdc or less.
Shutdown:	at 1.85 Vdc or less.



# WINRADIO<sup>®</sup>

PC Based Wide Band Communications Receivers

Computer based communications receivers designed for a wide range of professional and amateur applications.

- Sophisticated virtual control panel
- Wide-band coverage
- Fast scanning
- Powerful tuning and scanning options
- External and internal models
- Rich variety of innovative features
- Complete multichannel systems available
- Custom solutions for radio frequency monitoring applications

Pioneering the Integration of Radio and Computers

# WINRADIO<sup>®</sup>

## COMMUNICATIONS

### Creating New Standards

The award-winning and immensely popular WiNRADiO WR-1000i is the world's first commercially available PC-based wide-band communications receiver. Integrating advanced radio receiver technology and the computing power of a PC, it sets a new standard in radio communications.

The synergy of radio and computing technology provides all WiNRADiO receivers with many unique features which are hard to find on conventional communications receivers. These include a rich variety of tuning and scanning options, versatile memory and database facilities, and innovative user interfaces designed for flexibility and ease of use.

### WiNRADiO 1000/1500 series

The 1000/1500 series products offer cost-effective solutions for a wide variety of applications. The products come in two forms: internal ISA-bus cards, and compact external units with an RS-232 interface (PCMCIA interface optional).



Internal model (WR-1500i)

The advantages of an internal card model are in its neatness – there are no external cables required, no external interface ports are occupied, no external power supplies or extra desk space are needed. And if you wish, nobody needs to know that you have a scanning receiver hidden inside your PC!

Multichannel operation is simple to achieve, as up to eight WiNRADiO internal receivers can be used simultaneously in one PC.



External model (WR-1500e)

(Computer not included)

The advantage of an external model is in its portability – the optional PC card interface (PCMCIA) allows very fast and simple installation for any portable PC. Serial RS-232 interface is also available as standard.



The external models also feature a discriminator output.

Both models are very well shielded from PC interference. We use specially developed shielding materials and innovative design methods to prevent any interference directly entering the receiver.

### WiNRADiO Software

The 1000/1500 Series software works on Windows 3.11, 95, 98 and NT. Impressive high-resolution graphics combine with a variety of useful features, all logically and intuitively laid out.



The WiNRADiO software sets new standards for computer-controlled radio receiver interfacing. Its features include automatic mode and step size selection, duplex separation, user-definable frequency offset, a rich variety of scanning modes including multiple-range scanning, virtually unlimited number of memories, and many other powerful features.

The Spectrum Scope facility displays real time activity on the bands. It is complemented by our graphic tuning facility called Visitune™ (patent pending). This facility allows you to tune the receiver continuously, using the mouse, across the frequency spectrum visible in the background.



Click on a peak and you are instantly tuned. Alternatively, keep the left button down and drag your mouse across a scanned spectrum – you will see the frequency cursor moving, the frequency display updating accordingly and the receiver will be tuned following your hand movements!

### Optional Portable Power Source

Many external radio receivers neglect user convenience with respect to the availability of a suitable portable power supply. WiNRADiO provides a suitable external power source, to meet the most demanding standards.

The WiNRADiO Portable Power Source is based on high-capacity, long-life nickel-metal-hydride rechargeable batteries, coupled with intelligent, fast-charging circuitry which saves the battery life and guarantees maximum charging capacity. (Suitable for external models WR-1000e, WR-1500e and WR-3100e).

### Optional PC Card Interface

The PC Card interface (PCMCIA Type II) makes connecting a WiNRADiO receiver to a laptop or a notebook computer especially easy. The Plug-n-Play facility automatically registers the card, and the installation is very simple indeed. (Suitable for external models WR-1000e, WR-1500e and WR-3100e).



The PC Card Interface comes with a cable to suit



## Optional Digital Suite Software

The optional WiNRADiO Digital Suite is a collection of digital signal processing modules. Together, they represent a breakthrough in reception of digitally coded radio communications - never before has such a comprehensive collection been made available at such low cost and so elegantly integrated with a PC-based radio receiver.

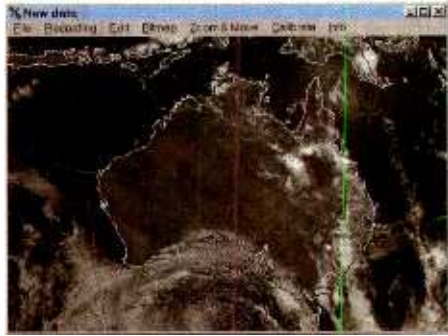

The WiNRADiO Digital Suite expands the power of a WiNRADiO receiver with numerous digital processing facilities, including:

- WEFAX (Satellite Weather Fax)
- HF Fax
- Packet Radio
- Aircraft Addressing and Reporting System (ACARS)
- Digital Tone Multi-Frequency Signalling (DTMF)
- Continuous Tone Coded Squelch System (CTCSS)
- Signal Classifier
- Audio Oscilloscope and Spectrum Analyzer
- Squelch-controlled Audio Recorder and Playback

## Optional Frequency Database Manager Software

The optional World Station Database Manager greatly simplifies the maintenance of frequency databases. It is fully integrated with the receiver software, and allows for instantaneous tuning to stations while browsing or searching within a database. Similarly, an unknown frequency can be readily identified by invoking the Database Manager.

Frequency	Location	Country	Class	Callign	Mode	Comments
133 2500 MHz	PLAINVIEW TEX	USA	Aviation	PLAINVIEW TEX RADIO	AM	
133 2500 MHz	SAGINAW MICH	USA	Aviation	SAGINAW MICH RADIO	AM	
133 2500 MHz	THERMOPOLI WYD	USA	Aviation	THERMOPOLI WYD RADIO	AM	
133 3000 MHz	GOODLAND KAN	USA	Aviation	GOODLAND KAN RADIO	AM	
133 3500 MHz	AUSTELL GA	USA	Aviation	AUSTELL GA RADIO	AM	
133 2500 MHz	MARIETTA GA	USA	Aviation	MARIETTA GA RADIO	AM	
133 4000 MHz	AUSTIN TEX	USA	Aviation	AUSTIN TEX RADIO	AM	
133 4000 MHz	FLORENCE SC	USA	Aviation	FLORENCE SC RADIO	AM	
133 4000 MHz	WHITEFISH MONT	USA	Aviation	WHITEFISH MONT RADIO	AM	
133 4500 MHz	TONOPAH NEV	USA	Aviation	TONOPAH NEV RADIO	AM	
133 000 MHz	ALBUQUERQUE NM	USA	Aviation	ALBUQUERQUE NM RADIO	AM	

The user can add, delete or edit database records as well as import data from other databases. The software comes with a ready to use database of over 300,000 stations world-wide.

## WiNRADiO 3100 series

Designed for government, military, security, surveillance and industrial applications, the WiNRADiO 3100 series puts advanced radio receiver technology directly on a personal computer platform to create a complete spectrum surveillance and monitoring system.



WR-3100i-DSP internal receiver

The WiNRADiO 3100 series receivers come in two forms: internal ISA-bus cards, and compact external units with an RS-232 interface (PCMCIA interface is optional). A dedicated Digital Signal Processor (available on the internal model only), is used for real-time audio recording and playback. Recording can be controlled manually or automatically using time presets or signal level thresholds.

WiNRADiO 3100 series receivers feature a practically unlimited number of memories, sophisticated search facilities, group allocations, automatic memory writing, exclusion list, frequency logging and much more. The in-built Task Manager makes it possible to program the receiver to perform many tasks automatically, and make decisions based on user-specified conditions. Up to eight independently operating receivers can be controlled by a single PC. The WiNRADiO 3100 series receivers represent an ideal solution for high-performance automatic monitoring systems.

## Complete Multichannel Systems

Until recently, the task of multichannel radio frequency surveillance and monitoring involved a number of separate radio receivers, audio recorders and other discrete components interconnected into bulky and expensive systems.

WiNRADiO Multichannel Systems provide an elegant, fully integrated solution, specifically designed for computer-controlled automatic monitoring of frequencies ranging from below the AM broadcast band up to low microwave, in all major modulation modes.

Available in several configurations to suit specific requirements for radio frequency monitoring, the systems are designed to monitor radio frequencies on multiple channels simultaneously, record digitized signals on the hard disk for easy later retrieval, and perform automatic decisions based on received signals.

WiNRADiO Multichannel Systems can be operated either manually or autonomously in unmanned remote locations. Remote operation and networking facilities are also available.



MS-8006 (six channel) Surveillance System

User-selectable audio compression methods make it possible to store weeks or months of continuous, simultaneous recording of all channels on the in-built hard disk.



WiNRADiO Multichannel Monitoring System software allows the user to observe the status of all received channels on a single screen using virtual "micropanels" for each channel, each one of them fully expandable to a full size panel.

Each expanded control panel allows for independent operation of a high-performance scanning receiver with sophisticated functions such as automatic task scheduler, spectrum scope, DSP signal conditioner, signal strength recorder, programmable audio recorder, and many other features.

## Specifications

Model Numbers	WR-1000i/WR-1000e	WR-1500i/WR-1500e	WR-3100i-DSP/WR-3100e
Type	Triple superheterodyne	Triple superheterodyne	Triple superheterodyne
Frequency range	0.5-1300MHz*	0.15-1500MHz*	0.15-1500MHz*
Modes	AM,FM-N, FM-W, SSB/CW	AM,FM-N,FM-W,USB, LSB, CW	AM,FM-N,FM-W,USB, LSB, CW
Tuning steps	100Hz (5Hz BFO)	100 Hz (1Hz USB/LSB/CW)	100 Hz (1Hz USB/LSB/CW)
IF shift	-	+/- 2kHz	+/- 2kHz
Audio output	200mW into 8 ohm load	200mW into 8 ohm load	200mW into 8 ohm load
Antenna connection	50 ohm BNC	50 ohm BNC	50 ohm BNC
Dynamic range	65 dB	65 dB	85 dB
Selectivity			
SSB,CW	6kHz/-6dB	2.5 kHz/ -6dB	2.5kHz/-6dB
AM	6kHz/-6dB	6 kHz/ -6dB	6 kHz/-6dB
FM-N	17kHz/-6dB	17kHz/-6dB	17 kHz/-6dB
FM-W	230kHz/-6dB	230kHz/-6dB	230 kHz/-6dB

\* In some countries, certain frequencies may be omitted to comply with local government regulations.

Typical Sensitivity for WR-1000i/WR-1000e receivers				
Frequency Range	AM	CW/SSB	FM-N	FM-W
0.5 - 1.5MHz	5.0µV	2.5µV	1.0µV	-
1.5MHz - 30MHz	1.0µV	0.5µV	0.5µV	-
30 - 1000MHz	1.5µV	0.7µV	0.5µV	2.0µV
1.0 - 1.3GHz	5.0µV	2.5µV	2.0µV	4.0µV

Typical Sensitivity for WR-1500i/WR-1500e receivers				
Frequency Range	AM <sup>(1)</sup>	CW/SSB	FM-N <sup>(2)</sup>	FM-W <sup>(2)</sup>
0.15 - 0.5MHz	<sup>(3)</sup>	<sup>(3)</sup>	<sup>(3)</sup>	-
0.5 - 1.8MHz	5.0µV	0.9µV	1.0µV	-
1.8 - 30MHz	1.0µV	0.3µV	0.5µV	-
30 - 1000MHz	1.5µV	0.3µV	0.35µV	1.8µV
1.0 - 1.5GHz	1.9µV	0.35µV	0.4µV	3.5µV

Typical Sensitivity for WR-3100i-DSP/WR-3100e receivers				
Frequency Range	AM <sup>(1)</sup>	CW/SSB <sup>(1)</sup>	FM-N <sup>(2)</sup>	FM-W <sup>(2)</sup>
0.15 - 0.499MHz	<sup>(3)</sup>	<sup>(3)</sup>	<sup>(3)</sup>	-
0.5 - 1.7999MHz	5.0µV	0.9µV	0.9µV	-
1.8 - 29.9999MHz	1.0µV	0.3µV	0.35µV	-
30 - 999.9999MHz	1.0µV	0.3µV	0.35µV	1.0µV
1.0 - 1.5GHz	1.5µV	0.35µV	0.4µV	2.0µV

<sup>(1)</sup> For 10dB S+N/N

<sup>(2)</sup> For 12dB SINAD

<sup>(3)</sup> Not specified

	WR-1000i/WR-1500i/WR-3100i	WR-1000e/WR-1500e/WR-3100e
Power supply	internal (PC supplied)	12V DC +/- 15%
Dimensions	114x290x18mm (4.5x11.4x0.7in)	122x216x48mm (4.8x8.5x1.8in)
In-built speaker	-	8 ohm 0.1W

## Ordering codes

- WR-1000i WiNRADiO WR-1000i receiver (internal)
- WR-1000e WiNRADiO WR-1000e receiver (external)
- WR-1500i WiNRADiO WR-1500i receiver (internal)
- WR-1500e WiNRADiO WR-1500e receiver (external)
- WR-3100i-DSP WiNRADiO WR-3100i-DSP (internal)
- WR-3100e WiNRADiO WR-3100e (external)
- WR-DBM WiNRADiO Database Manager Option
- WR-DS WiNRADiO Digital Suite Option
- WR-PCA WiNRADiO PC Card Adaptor Option
- WR-PPS WiNRADiO Portable Power Source
- MS-8003 Multichannel Monitoring System (3 channel)
- MS-8006 Multichannel Monitoring System (6 channel)

**WiNRADiO**<sup>®</sup>  
COMMUNICATIONS

WiNRADiO is a trademark of WiNRADiO Communications.  
All other trademarks are the property of their respective owners.  
Technical specifications are subject to change without notice.  
Patents pending.

www.winradio.com  
© 1999 WiNRADiO Communications

Authorized Distributor:

**Advanced Digital Systems**  
of Saint Louis, Inc.



Visit us on the Internet for more information and free software!

[www.advdig.com](http://www.advdig.com)

or email us at [winradio@advdig.com](mailto:winradio@advdig.com)

Dealer inquiries invited.

Phone: (314) 791-1206

Fax: (314) 458-1597

1374 Clarkson/Clayton Center, St. Louis, MO. 63011 USA



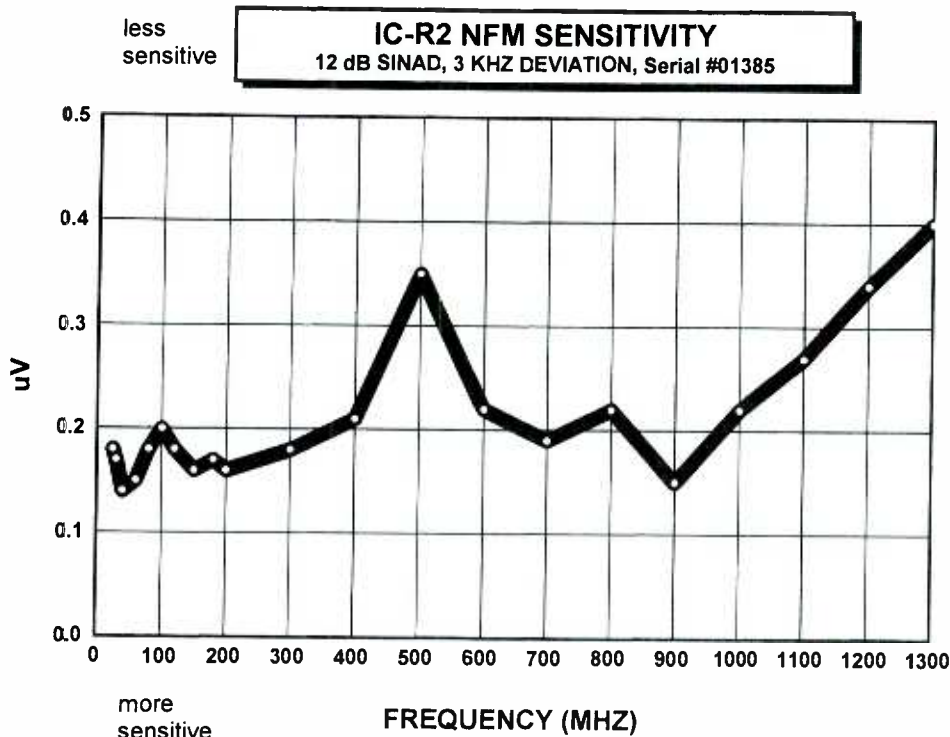

ity. Audio power available at the headphone jack measures less than 100 mW, but that's not a reliable indicator of how the radio actually sounds when using the internal speaker. Many models, e.g., the Uniden BC200XLT, use a resistor to limit the audio available at the earphone jack, though we don't know if that's true in this case.

Though the radio is small, the frequency digits are large enough to see without squinting. A green LED lights the LCD display for 5 seconds each time you press a key to twist the selector knob. You can latch the light so it stays on.

VHF and UHF reception is very good. My IC-R2 is quite sensitive, in the vicinity of 0.2  $\mu$ V SINAD below 1000 MHz as shown in the accompanying graph. Reception is clean and mostly free from images and intermod, though I do receive paging intermod near 860 MHz while in close proximity to a transmitting tower, and a friend's IC-R2 hears intermod near 476 MHz. When searching for NFM signals, my IC-R2 often stops 5 kHz away from the center frequency of an active transmission.

None of the handheld scanners I've tested lately, including my IC-R2 (S/N 01385), hears well on shortwave. That's due to the supplied antenna, not because the radio is insensitive. At the other extreme, my IC-R2 overloads on shortwave and medium wave when connected to a 132-foot dipole — even when using the global, internal attenuator. The best compromise is a random length of wire a few feet

long.

Don't expect to use the IC-R2 to monitor shortwave utilities because it has no product detector or fine step size for SSB reception.

#### ■ Go for It

At a street price of about \$220, the IC-R2 is a great value and an impressive performer in a tiny package. For me, it was love at first sight. The affair will continue 'til the day that I am forced to return this loaned IC-R2 to Icom.

## ITT Mackay Marine 3031A Receiver

This is supposed to be a scanner equipment column, but readers may enjoy learning about an older, exotic shortwave / longwave receiver which I recently acquired — an ITT Mackay Marine model 3031A. Made in USA, the 3031A is a 1980s vintage dual conversion solid state model used aboard ships and in coastal stations. It tunes 15 kHz - 30 MHz in 10 Hz, 100 Hz, or 100 kHz steps. Frequencies

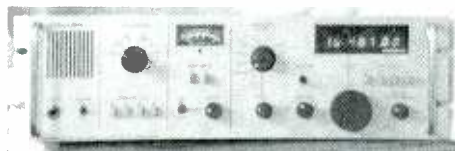

ITT Mackay Marine 3031A, a 1980s vintage 15 kHz-30 MHz receiver

are boldly displayed down to 10 Hz resolution on a large red LED readout. Velvet smooth tuning is accomplished using a fly-wheel weighted optical chopper.

Intended for maritime use and 19-inch rack mounting, the Mackay is built like a tank and has 1 PPM (part per million) stability, too. The front panel is an aluminum rack panel — no sculpted plastic here! The IF bandwidths are 8, 2, 1, and 0.4 kHz.

An internal 9-band preselector permits honest VLF reception without interference from strong broadcast band stations, but the preselector can be bypassed. The 3031A contains no memory channels or noise blanker, though an internal NiCd battery remembers the VFO frequency when the power is off. Like other marine and military receivers, there's a fixed level, 600 ohm audio output connection on the rear panel in addition to a 3.2 ohm speaker port. The front mounted speaker employs a huge magnet and produces better audio than my fancier imported radios.

Mackay Radio Systems, Inc., now a part of Thomson-CSF, is still making radio communication gear. They are located at 2721 Discovery Dr., Raleigh, NC 27616.

**RadioMap™**

Transmitter sites in your area are researched and marked on a beautiful 8-1/2 x 11 full color plot. See FCC licensed sites from VLF through microwave including police, fire, cellular phone sites, business, industrial, broadcasters and selected FAA transmitter sites. Call signs, frequency assignments, and names provided. Ham radio stations not included.

You choose the map center location—your neighborhood, near your office, around sports stadiums—anywhere within the United States. We adjust map coverage for best readability, depending on transmitter site density.

Invaluable to radio professionals and hobbyists for identifying towers, sources of radio interference etc. Send nearest street intersection and check for \$29.95 payable to Robert Parnass.

Robert Parnass, M.S.  
Radio Electronics Consulting  
2350 Douglas Road, Oswego, IL 60543

**Motron** PO Box 2748  
Eugene, Oregon 97402

**ELECTRONICS** (800) 338-9058

DTMF Decoder/Display w/ASCII Conversion  
DTMF & Rotary Test Decoder  
TxID Transmitter FingerPrinter Board & Software  
TxID TxPorter Mobile Adaptor  
DTMF to ASCII & ASCII to DTMF Transceiver  
Remote Relay Controllers & Relay Boards  
Custom OEM Design & Manufacturing

Product Catalog With Full Color Photos  
Available Online At:  
**Http://www.motron.com/**

Information also available by Phone or Fax:  
Tel: (541) 687-2118 Fax: (541) 687-2492

### More on Digital Shortwave

In our February issue, I mentioned that several digital techniques had been tried on shortwave, but without much success. WWCR's George McClintock adds that the experiments showed that 60 kHz of composite bandwidth would be required to handle the digitized signal, and shortwave assignments are 10 kHz wide.

And how about single sideband? Informally, says George, the global broadcasters have affirmed that they will never go to single sideband (SSB) because of incompatibility with the vast majority of shortwave radios spread among world listeners.

Don't throw away that AM-only radio; it looks as if AM shortwave will be with us for some time to come!

**Q.** I gave myself a Christmas gift of the Grundig Deco table radio primarily to listen to the AM band

and get that "way it should be" feeling from the lighted dial, wooden cabinet and big tuning knobs. Tuning around the top end of the AM dial, around 1700, I was quite surprised to hear John Peel on the BBC. I also receive Deutsche Welle and some Spanish-language stations at this end of the dial. Why do I get this bonus, when I don't on other radios like my GE Super Radio? (Dale Hazelton, New Hampton, NY)

**A.** This "bonus" is actually a deficiency in design. You are hearing shortwave "images" from higher frequencies, a result of inadequate filtering in the front-end tuner of the radio. The GE Super Radio is known for its superior filtering and doesn't suffer from (or, in your case, benefit from!) this image response. But if

you like hearing them, and they aren't interfering with signals you want to hear in that part of the spectrum, then it is a bonus for you.

**Q.** Is there any way to recognize when the signals from the US Navy's High Frequency Active Auroral Research Program (HAARP) in Alaska are on the air? (Angus Ashdown, Lexington, MO)

**A.** Not that we've been able to determine. The program conducts experimental transmissions on an assortment of frequencies, but since the radiation pattern is straight up, very little effect is noticed at lower latitudes.

Edward Kennedy, who recently contacted us on behalf of HAARP about a different kind of listening test (see p. 6, March *MT*), affirmed that the only noticeable effect would be on signals whose propagation path passes over the facility. He says, "The HF transmissions

## Bob's Tip of the Month

## Unusual Solutions for the Technically Adept

**Synchronous Detection** - A recent discussion with *MT*'s Scanner Equipment columnist, Bob Parnass, got us thinking. Many good communications receivers and amateur transceivers don't have synchronous detection. The addition of the time-honored Sherwood SE-3 accessory would add some \$500; are there less expensive options?

Couldn't an inexpensive, new or used, synchronous-detector-equipped receiver like a Drake SW2, or Sony ICF2010 or ICF7600G be used instead? The inexpensive radio would be connected via coax between its external antenna jack and the host receiver's intermediate frequency (IF) output jack, and adjusted to the correct IF frequency. If the host receiver is not equipped with an IF output jack, the technically competent experimenter could install a jack, shielded jumper, and direct current (dc) blocking capacitor to the IF output stage of the host receiver.

The advantage of such a scheme would be that the add-on radio could be set to the intermediate frequency of the host receiver (455 kHz, 5 MHz, 9 MHz, etc.), while a dedicated synchronous detector like the Sherwood is set at 455 kHz, and it's another \$150 for a converter. The secondary receiver can still be used as a backup receiver.

**Digital RF Signal Generator** - Scanner listeners using multiple radios often complain about oscillator radiation from one scanner being heard on another scanner, blocking reception on certain frequencies. While this is a detriment to listening, it "signals" another use.

Radio experimenters looking for a stable, reliable signal source for testing receivers can use a keyboard scanner as a signal generator. Less expensive double-conversion units are best because the math is simpler!

If the scanner has a 10.8 MHz IF stage

(typical Bearcats and Uniden-manufactured Radio Shack scanners; occasionally 10.7 MHz on other models), you would either add or subtract 10.8 from the dial reading (depending upon which band you are on) to determine the oscillator frequency radiating from the unit.

For example, the oscillator of a PRO-51 set to 130.000 MHz on the aircraft band will be heard on 140.800 MHz on a nearby scanner, while the same PRO-51 radiates on 160.000 MHz when set at 170.800 MHz.

Using this basic equation:  
Signal Frequency = Dial Frequency +/- 10.8 MHz

you can make a chart, or write the equation, enabling the use of virtually any keyboard scanner as a radio frequency (RF) signal generator. Of course, you will need a second radio to confirm the conversion frequencies for your model scanner.



themselves are generally narrow bandwidth, remain on one frequency for the duration of the test, and, as you say, with the antenna pattern upward." For more information, visit the HAARP Web site at <http://server5550.itd.nrl.navy.mil/projects/haarp/index.html>

**Q.** In your January column, you said there is no licensed Citizen's Band (CB) service on Earth. That may be true now, but when I got my CB license in the 60s, my FCC-issued callsign was KFO-9386. (Leonard Lykens, Harrisburg, PA)

**A.** I'll do you one better: I used to operate legal 11 meter ham radio as a Novice, and when the 27 MHz band went CB, my FCC-issued callsign in the 50s was 19A7074, later changed to comply with international regulations to KOP0205.

**Q.** I recently compared two shortwave wire antennas of identical length, one made of #14 copper wire, the other made from a length of 3/4" hardline coax. The antennas were end-fed by a length of RG-6/U coax connected to a Kenwood R2000 receiver. Both antennas were alternately suspended at the same height, in the same manner, at the same location. I tried them extended, in zig-zag patterns, even on the ground.

I realize that reception should not be improved by thickness of the wire, yet on all frequencies, the signals heard on the thicker 3/4" hardline were consistently stronger, even showing higher on the S-meter, than those heard by the wire. Why is this? (Name withheld)

**A.** This is one of those exasperating cases where the answer is, "You're wrong — it can't possibly be." Yet you say it happened. Any ideas, readers?

**Q.** Why don't you cover more of the worldwide freeband communications between 26 and 28

MHz? Are you concerned that hams will disapprove? Do you think the FCC will eventually approve of the unlicensed usage? (Bob Schultz, St. Louis Park, MN)

**A.** There really isn't much to say about this embarrassing part of the spectrum that hasn't already been covered in past issues — it doesn't change. And it isn't a ham band, so we aren't concerned for hams' approval or disapproval.

The Federal Communications Commission threw up their hands and deregulated the CB service (officially 26.965-27.405 MHz) years ago and, due to budget and personnel restraints, no longer enforces infractions such as out of band operation, high power, abusive language, international communications, unapproved equipment, improper modes, noise makers, and other artifacts of a communications medium run amok.

Because of the worldwide phenomenon of zillions of people talking all at once (often with no one listening!), legitimate radio services globally have abandoned 26-28 MHz for serious use.

If there is interest in our doing another freeband article, or an update on the CB radio service, we will be happy to do so. So far, most reader sentiment has seemed against it.

## VisualRadio® you are in control

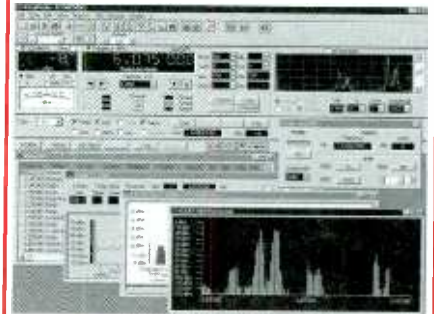

VisualRadio® is a powerful control software for AOR, ICOM, Kenwood, JRC, YAESU and more. Now **PCR-1000** protocol licensed by **ICOM®**. Starting at \$128

### COMPUTER INTERNATIONAL

St. Johns, MI 48879-2465  
Tel/Fax (877) 977-6918 toll free  
E-mail: [schuette@email.mintcity.com](mailto:schuette@email.mintcity.com)  
<http://computer-international.virtualave.net>

# TrunkTrac®

## New Version 5.2



TrunkTrac, the first, and one of the most sophisticated trunk tracking technologies available, is now even better. New pricing and additional features make TrunkTrac your best choice if you're serious about tracking Motorola Type I, II, III, and Hybrid systems. TrunkTrac now supports the BC895XL, PCR1000, R7000, R7100, R8500, R9000, and the RS Pro 20xx series with an OS456/535 board installed.

Competing products cost more, don't decode the control channel, can't deal with Type I fleet maps, and won't properly decode many Type II talk groups. TrunkTrac's patented technology lets you do all that and much more. TrunkTrac consists of easy to use menu driven software, an FCC Class B approved signal processing board you plug into an ISA slot in your PC, a serial interface, and a discriminator buffer for your scanner. Everything you need, including cables, is supplied. With TrunkTrac you'll have access to Private Call and Interconnect activity and can follow up to four systems at once. Any combination of VHF/UHF/800/900 MHz systems, including FED-SMR trunking, is supported. TrunkTrac lets you assign a 35 character alpha tag (up to 1000/system) to all IDs. You can set Lockouts, Personality Files, Scan Lists, and much more. TrunkTrac lets you log system activity to an ASCII file for database import and traffic analysis. We think you'll like TrunkTrac so much it comes with a 30 day money back guarantee. And for a limited time, when you purchase TrunkTrac, we will install the discriminator mod in your scanner for free. **TrunkTrac ver 5.2.....\$297.95**

Scanner Master PO Box 428, Newton Highlands, MA 02161 1-800-722-6701  
[www.scannermaster.com](http://www.scannermaster.com)

# AVCOM SDM42A Spectrum Display Unit

By Bob Grove

It has been some time since low cost spectrum display units (SDUs) have been available to consumer radio monitors. Those serious listeners who are fortunate enough to have one agree that they are indispensable, and having a tunable VHF/UHF receiver without one is like listening to TV with your eyes closed.

An SDU with a wide-frequency-coverage receiver is the virtual equivalent of a spectrum analyzer, and audio detection is even better than a spectrum analyzer. Applications include locating and identifying unknown signals, sweeping for illicit transmitters, antenna adjustment, receiver and transmitter alignment, filter design and testing, interference tracking, and more.

Most signal sleuths without the benefit of such a marvelous device are limited to tuning up and down the dial manually, hoping to hear a signal transmitting just at the time they tune across its frequency, or they must allow a scanner to laboriously search slowly across the band hoping for the same coincidence. But with an SDU, you are instantly alerted to the presence of a new signal; a quick turn of the tuning dial snags it for identification.

Currently, with the Grove SDU-100 discontinued, only the AOR SDU5500 is readily available, and it is primarily suited to match the AR5000 and AR5000 Plus receivers.

AVCOM, a leading manufacturer of cost-effective test equipment, has a universal alternative: the SDM42A, a lightweight (8 lb.), small profile (8-1/4" x 5" panel), 5-inch diagonal cathode ray tube

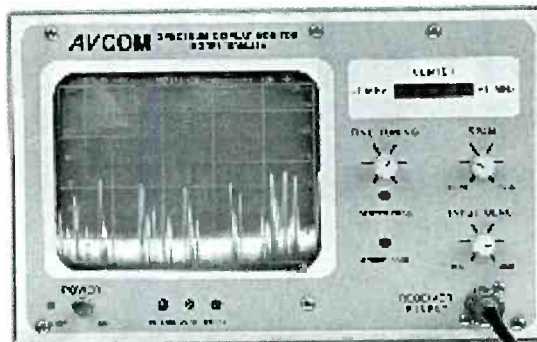

(CRT) 'scope available for any receiver with an intermediate frequency (IF) output of 10.7, 21.4, 45, or 70 MHz. A BNC interconnect cable is included, and the SDU is powered by 120 Vac (a minor limitation for mobile applications).

With its 10 kHz resolution bandwidth filter, the signal spikes are sharp and clean, but limited to 65 dB dynamic range, according to the specs (we measured 55 dB on the scale); above that, intermodulation generates phantom spikes ("spurs"). Reducing the gain helps, but eliminates weak signal spikes. Perhaps better gain distribution could have prevented this limitation which makes it difficult to resolve weak signals in a strong-signal field.

A continuously variable span allows a view of the spectrum from 0-10 MHz wide, conforming to compatible receivers like those from ICOM, AOR, and government/military vendors. At 0 span, the scope displays time domain, revealing modulation waveform for visual analysis.

Initial adjustment couldn't be simpler: With a signal tuned in, the input sensitivity control is adjusted for desired vertical amplitude (10 dB/division sensitivity), the fine tuning control centers the spike, and the span control selects the desired spectrum

width. That's it.

A few trim pots are accessible from the front panel for tweaking if necessary; these include intensity, vertical and horizontal centering, center frequency spike adjustment, and sweep rate. A five-segment LED bargraph gives a coarse visual indication of the selected span up to 2 MHz wide. While that is nice, having it continuously adjustable up to the full 10 MHz span would make

more sense.

After a few minutes' warmup, the trace is quite stable, far more stable than the more expensive PSA65C spectrum analyzer which drifts continuously. An occasional touch of the SDU's fine tuning control every few minutes keeps the signal spikes dead on center.

It's hard to fault a piece of equipment that works so darned well, but an edge light on the graticule, or even imprinting, would make the scaling far more legible; a coarse calibration of the span control would let the user know approximately how much spectrum he is watching; and a switch to reverse the sweep direction would allow the user to choose whether the span goes from low to high, or high to low, frequency. Most important, a 12 volt power capability would dramatically improve the SDU's desirability in mobile applications.

But just as it is, owners of receivers with IF outputs are short-changing themselves without such a useful accessory.

The AVCOM SDM42A is available for \$999.95 plus shipping from Grove Enterprises, PO Box 98, Brasstown, NC 28902 (800-438-8155 or visit [www.grove-ent.com](http://www.grove-ent.com)).



# WHAT'S NEW?

TELL THEM YOU SAW IT IN MONITORING TIMES

## Bearcat Bonanza!

Grove Enterprises has acquired a large stock of factory-tested handheld Uniden scanners and is selling them at rock-bottom prices—as much as a hundred dollars off retail. These units are in as-new condition and come with a 90-day warranty.



The 200-memory-channel BC220-XLT, with preprogrammed service and weather radio search, covers 29-54, 118-174, 406-512, and 806-956 MHz, and boasts 10 priority channels, data skip, and 100 channel per second scan speed—priced at \$149.95. The popular SC150

Sportcat handheld scanner covers the same frequency range as the 220XLT, has 100 memory and 10 priority channels, with preprogrammed band search capability and weather radio—all for \$99.95.

The Uniden BC100-XLT excludes the 800 MHz range, but contains 100 memory channels, 10 priority channels, and weather search for the price of \$69.95. The Bearcat 60-XLT covers neither the 800 MHz nor 118-174 MHz ranges, but it does have 10 memory channels and weather scan for the low price of \$49.95. Both these handhelds scan more slowly (10-15 chan/sec) than the more sophisticated units. For information and availability call Grove Enterprises at 800-438-8155 or check Bob's Bargain Bin off the Grove website at [www.grove-ent.com](http://www.grove-ent.com)

## HF Communications Receiver from Icom

Details are beginning to emerge on Icom's upcoming all-mode shortwave communications receiver, the IC-R75, touted as the successor to the Icom IC-R72. The wide-range receiver is designed for optimum reception on HF (0.03 - 30 MHz) and at 50-54 MHz (the 6 meter band).

Twin passband tuning narrows the intermediate frequency (IF) passband in two stages for more effective elimination of interfering signals. Up to two optional



filters may also be installed for more flexible filter combinations. A synchronous detector is provided to prevent audio distortion in AM signals. Sound quality may be further improved with an optional audio frequency digital signal processor (AF DSP).

The receiver is tuned via program scan (two sets of limits may be saved in memory), memory channel scan (99 channels), or priority scan (scan of main frequency plus selected memory channels), or by direct frequency or memory channel input from the keypad. An option to be available in the future is computer control using a standard serial cable and RS-R75 remote control software.

Watch for more news on this long-awaited offering from Icom, slated for an April or May appearance.

## NEW! FREE-POWER RADIO FROM SONY!

The new ICF-B200 provides not only quality AM/FM reception in a tiny (6"x3"), lightweight (11 oz.) case, but also never needs batteries or sunlight to operate! That's right, a high efficiency, easy-hand-turned generator provides all the power needed for this radio—one minute's spin gives you a full half hour of play time! And you can even install two AA alkaline batteries for many hours of unattended, extended operation! An LED status indicator alerts you to charge conditions.

Need emergency lighting? The B200 has a built-in emergency light, and its display is illuminated as well. A headphone jack allows private listening, or you can call for help with the audible alarm. The bright, safety-orange color quickly locates the radio under all conditions.

Be ready for power outages—don't be caught without a source of emergency information! Call now to order your lifeline to the community!



Order RCV-12,  
only **\$79.95**  
plus \$5.50  
shipping

### GROVE

GROVE ENTERPRISES, INC.  
1-800-438-8155 US and Canada  
828-837-9200 • FAX 828-837-2216  
7540 Highway 64 West • Brasstown, NC 28902-0098  
e-mail: [order@grove-ent.com](mailto:order@grove-ent.com)  
[www.grove-ent.com](http://www.grove-ent.com)



## Have Station, Will Travel

For the amateur or the monitor on the go, Cutting Edge Enterprises has added to its line of portable power supplies. Their new HAM-Pack will let you carry your 110 Watt station on your back or in your car. A lower compartment holds a rechargeable power supply, and a pocket on the side holds your mobile antenna. The lid contains a pocket for microphone storage.

The backpack is constructed of laminated heavy duty black nylon with 1/4-inch foam padding. An adjustable radio sling holds the radio securely in the top compartment, but allows it to be

raised for easy operation. Power cords pass through openings into the lower power compartment.

The pack can be toted by a handle at the top when not worn as a backpack. The company claims it's "small enough to qualify as airline carry-on luggage, is complete enough to serve as an entire station, and is comfortable enough to carry for miles."

Cutting Edge offers a special introductory price of \$47.95 for the HAM pack. If you don't have a power supply, you can purchase CEE's kit for \$63.95. To order, call 800-206-0115, email [cee@cruzio.com](mailto:cee@cruzio.com), or write Cutting Edge Enterprises at 1803 Mission Street, Suite #546, Santa Cruz, CA 95060.

## RuffRider Mobile Antennas

MFJ Enterprises has an entire

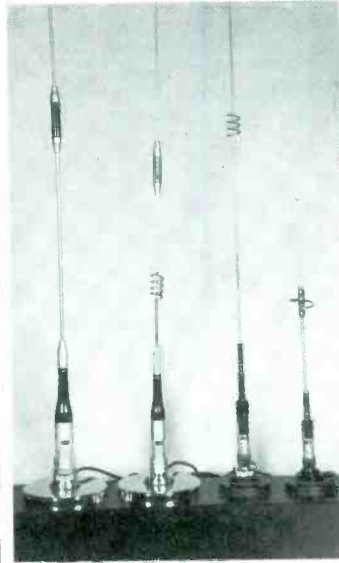

line of mobile antennas for the ham which they have dubbed RuffRider™ for their ability to "battle the elements, handle rugged rides and day-to-day highway abuse." All are dual band 144/440 MHz antennas with

stacked elements and high-Q phasing coils housed in weather-proof plastic insulation attached to stainless steel radiators. The heavy duty bases are super rigid. The sturdy antenna mounts have an SO-239 base, with a free NMO adapter included, plus Allen wrenches, locking screws and protection caps.

Antenna lengths vary from 16-1/2 inch to 62-1/2 inch, with a variety of mounts; prices range from \$34.95 to \$69.95. Call MFJ at 800-647-1800 for your nearest dealer, or email [mfj@mfjenterprises.com](mailto:mjfj@mfjenterprises.com).

## Clear Speech Speaker

Algorithms are hot these days: They produced MT's eye-popping cover this month, they are producing record-breaking reception when used for antenna design, and they are also being used to cancel irritating noise and static in radio reception.

DEDICATED TO THE SCANNING AND SHORTWAVE ENTHUSIAST. WE'RE MORE THAN JUST SOFTWARE!

## SCANCAT GOLD for Windows "SE"

Since 1989, The Recognized Leader in Computer Control

NOW SUPPORTS  
 • FULL TRUNKING UNIDEN BC-895  
 • ICOM IC-PCR1000  
 • OPTOELECTRONICS OPTOCOM  
 • TEN-TEC RX-320

Once you use SCANCAT with YOUR radio, you'll NEVER use your radio again WITHOUT SCANCAT!

SCANCAT supports almost ALL computer controlled radios by: AOR, DRAKE, KENWOOD, ICOM, YAESU and JRC (NRD) Plus PRO-2005/6/35/42 (with OS456/535), Lowe HF-150, and Watkins-Johnson.

### SCANCAT GOLD FOR WINDOWS "SE" (Surveillance-Enhanced)

#### FEATURES

- Selective Sound Recording using PC-compatible sound card.
- "Point & Shoot" playback by individual hits.
- Demographic search for frequency co-ordination and 2-way Usage Analysis.
- Detailed logging to ASCII type files with DATE, TIME, Sig Str, Air Time.
- Exclusive "MACRO" control by frequency of Dwell, Hang, Resume, Sig. Threshold and even 6 separate programmable, audible alarms.
- Command line options for TIMED ON/OFF (Unattended) logging/searches.
- Run as many as 6 different CI-V addressable radios as "Master/Slave."

#### SEVERAL GRAPHICAL ANALYSIS MODES AVAILABLE

With Scancat Gold for Windows "SE," your spectrum never looked so good! Load virtually "any" database and Scancat "SE" will examine your database, plot each and every frequency, no matter what the range...and "paint" the entire analysis on your screen.

- By Signal Strength per frequency in a "histograph"
- By Signal Strength plotted in individual dots.
- By Number of hits per frequency in a "histograph"
- IF THAT ISN'T ENOUGH, try this...Multicolored, 3-D "Spatial Landscape" (Depicted at left).

SCANCAT GOLD "SE".....\$159.95 + S & H\* UPGRADE SCANCAT GOLD FOR WINDOWS "SE".....\$59.95 + S & H\* \*\$5 U.S. \$7.50 FOREIGN

#### SCANCAT'S WINDOWS FEATURES

- Unattended Logging of frequencies
- Scan Create Disk Files
- Spectrum Analysis to Screen OR Printer.
- LINK up to 100 Disk files or ranges.
- Supports PerCon, Mr. Scanner, and Betty Bearcat CD Roms.
- Scan VHF & HF Icom's Simultaneously
- MULTIPLE search filters for Diskfile Scanning
- UNLIMITED file sizes with our exclusive SCANCAT filing method
- Search by CTCSS & DCS tones with OS456/535 or DC440 (ICOM only).
- INCLUDES several large shortwave and VHF/UHF databases

All the features you EXPECT from a true Windows application such as:

- UNIQUE database management system with moveable columns. Even SPLIT columns into doubles or triples for easy viewing of ALL important data on one screen.
- Exclusive "SLIDE RULE" tuner. Click or "skate" your mouse over our Slide-Tuner to change frequencies effortlessly! OR use our graphical tuning knob
- VERSATILE "Functional" spectrum analysis. NOT just a "pretty face" Spectrum is held in memory for long term accumulation. Simply "mouse over" to read frequency of spectrum location. "CLICK" to immediately tune your receiver. You can even accumulate a spectrum from scanning DISKFILES of random frequencies! DIRECT scanning of most DBASE, FOXPRO, ACCESS, BTRIEVE files WITHOUT "importing"

SCANCAT GOLD FOR WINDOWS (NON-"SE").....\$99.95 + S & H\* UPGRADE.....\$29.95 + S & H\* \*\$5 U.S. \$7.50 FOREIGN

### MAGIC for Windows

PUT SOME ORDER IN YOUR LIFE!

If You're Not Using MAGIC, You're Only Enjoying Half The Hobby.

Magic is a super conversion utility that will read and write to over 10 database formats

- Creates databases from plain ASCII text.
- Finds single or multiple frequencies located anywhere in source files and creates perfectly aligned database files.
- Converts: SCANCAT, ASCII text, comma delimited, HTML, DBase, ScanStar, RadioManager and ScannerWear.
- NEW WINRADIO, "WRM" files and PCR1000 "MCH" files.

**MAGIC for Windows \$34.95**  
 (plus \$5.00 S & H)

### LIMITED TIME OFFER!

Limited Time Thru 5/1/99

**SCANCAT GOLD "SE"/CAT-232C**  
 Buy Scancat Gold for Windows "SE" and our CAT-232C "Uni-Versatile Interface," and receive a FREE "Disk Full of Frequencies." A \$274.95 value (if purchased separately) for only \$249.95  
 No Minimum Purchase Required  
 Please Ask For Special "SCG-UNI!"

### "UNI-VERSITILE" INTERFACE

- Supports ICOM/IC-R10, AR8000, YAESU and SCOUT.
- Comes with 6 FOOT cable, and adapters to fit all units within a single package (Must Specify Yaesu)
- Unlike "single radio" adapters, can be used with ANY radio supported, simply change the adapter, then "Plug and Play."
- Expandable in future with a simple add on adapter
- No external power required. Draws power from computer.
- "Reaction Tune" scout with NO modifications to radio.



AR-8200B Cables/Interfaces -CALL! BC-895 Cables \$29.95

INTERNET WEB ADDRESS - <http://www.scancat.com> WEB E-MAIL - [scancat@scancat.com](mailto:scancat@scancat.com)

\$99.95 + s & h

Order direct or contact your favorite dealer

### COMPUTER AIDED TECHNOLOGIES

P.O. Box 18285 Shreveport, LA 71138

Toll-Free Orders

FREE DEMOS ON THE WEB



Phone/Orders: (318) 687-4444 FAX: (318) 686-0449

Info/Tech Support: (318) 687-2555 (9 am - 1 pm Central M-F)



**888-SCANCAT**  
 888-722-6228





Noise Cancellation Technologies, Inc. (NCT) has announced their new ClearSpeech-Speaker™ specially designed for the spoken word. NCT claims that up to 95% of stationary or constant noise can be removed from a signal containing noise and speech. And, as the noise changes, the algorithm adapts.

"ClearSpeech-Speaker is great for use with mobile radios, fleet communications systems, marine and ham radios and many other communications systems," says Michael J. Parrella, President of the Stamford, Connecticut, company. "It's perfect in situations where communication is critical and noise hampers intelligibility."

For more information call 800-278-3526 or visit [www.nct-active.com](http://www.nct-active.com).

## Computer-Modem Surge Protection

If your household is like ours, it's plugged into the outside world via phone lines, cable connections, electrical connections, and even satellite connections. These circuits can also provide a conduit for damaging electrical surges, brown-outs, and lightning strikes

TrippLite's Super 10 Surge Protectors provide protection for two phone connections and ten electrical outlets (two of which remain on, even when the unit is switched off, to provide power to clocks, fax and answering machines, etc.). Three LEDs indicate power line problems; the Deluxe model also indicates damaging low voltage conditions. The

DBS model also features gold-plated coaxial F connectors and RJ11 jacks for home theater and satellite system equipment.

Super 10 and Super 10 DBS models retail for \$79.95; the Deluxe mode goes for \$99.95. For the dealer nearest you call 773-896-1234 or visit [www.tripplite.com](http://www.tripplite.com).

## Weather software from Timestep



Another way to protect equipment is to watch the weather. "PROsat for Windows i" is the latest weather satellite reception interface and software available from Timestep, manufacturer of weather satellite equipment. The "i" products are new versions of

Timestep's Windows interface and 32 bit software and contain every conceivable feature to provide totally stunning live weather fax images.

The new interface, which connects to the computer serial port and can be used with a notebook or desktop, can take up to three different receivers. All switching is computer controlled; system monitoring and status are shown by 11 LEDs on the front panel.

New features include: multi-spectral color NOAA APT images, zoom in and out while receiving, multiple windows for the same image (e.g. to view NOAA IR/visible simultaneously), continuous polar auto-save scheduled to receive all passes with no user intervention, and color animation.

The new PROsat for Windows Interfaces and i software are priced from £120.00; i software upgrades for existing Timestep

# DEDICATED TO THE SCANNING AND SHORTWAVE ENTHUSIAST. WE'RE MORE THAN JUST SOFTWARE!

## CAT-5000

### SPECTRUM ANALYSIS ON YOUR PC

- With the addition of AOR's SDU-5000 Spectrum Analyzer and this NEW Windows Software any radio that has a 10.7MHz IF output will give you full computer controllable spectrum analysis.
- Plus, with the listed radios below, you can have a complete computerized control of receive frequency, direct frequency readout, and a spectrum bandwidth (variable from 500KHz to 10 MHz)
- Just use your mouse to "arm chair" the controls. Never touch the radio once the software is running

#### Supports

- AR3000A, 5000
- R7000, R7100 ICOM
- Most ICOMs with 10.7MHz IF

#### Features

- Variable bandwidth, up to 10.7 MHz.
- Instant Readout of Frequency any place on the PC's Display.
- Instant change of center frequency with a simple mouse click.

#### Indicates for above listed radios only.

- Save Spectrum data to disk. Playback of Recorded Spectrum data from disk.
- Signal Averaging, PLUS our exclusive "VARI-COLOR" Analysis.
- Variable Peak Readout. Playback of Recorded Spectrum data from disk.
- THREE different graphical analysis modes.
- Download our demo for test drive.

- Minimum Requirements • IBM PC 8 meg ram • Windows 3.1 or later • 8 meg Hard Drive

## COPYCAT-PRO

The ONLY Commercially Available Computer Control Program for the Universal M-7000 & M-8000. Also, AEA's PK-232 and the MFJ-1278

### COPY-CAT PRO FEATURES

- 32K incoming text buffer
  - Runs on any 640K PC-Compatible
  - Control BOTH you TNC and radio simultaneously!
  - Multiple pop-up windows for HELP, frequency files, and text editor.
  - Supports ALL SCANCAT files.
  - Download our demo for test drive
- Discover our revolutionary COMPUTER CONTROL PROGRAM for the M-7000, M-8000, PK 232, and MFJ-1278. Let COPYCAT-PRO free you FOREVER from remembering all those buttons and keys. COPYCAT-PRO does it all. Simple "PULL-DOWN" menus control all functions. Fully editable text buffer. 20 PROGRAMMABLE "M" menus and much more.

COPYCAT-PRO \$79.95, UPGRADES \$24.95 S & H \$5.00 (\$7.50 Foreign)  
Specially wired cable for the M-7000/8000 \$24.95

## CAT-WHISKER

### TIRED OF YOUR HANDHELD SCANNER FALLING OVER?

- Try our unique, swivel base, telescopic scanner antenna. CAT-WHISKER lets you lay your handheld scanner on its back and still keep the antenna vertical!
- Swivels to ANY angle, adjusts to any length.
- Fits ANY scanner with a BNC antenna connector.

CAT-WHISKER #1 (5 to 23 inches)...\$19.95  
CAT-WHISKER #2 (6 to 36 inches)...\$24.95  
plus \$3.00 S & H

INTERNET WEB ADDRESS • <http://www.scancat.com> WEB E-MAIL • [scancat@scancat.com](mailto:scancat@scancat.com) (S & H \$10 US, \$15 Foreign)

Order direct or contact your favorite dealer

FREE DEMOS ON THE WEB



## COMPUTER AIDED TECHNOLOGIES

P.O. Box 18285 Shreveport, LA 71138  
Phone/Orders: (318) 687-4444 FAX: (318) 686-0449  
Info/Tech Support: (318) 687-2555 (9 am - 1 pm Central M-F)



Toll-Free Orders  
**888-SCANCAT**  
888-722-6228

## HOKA CODE-3 USA Version

"The Standard Against Which All Future Decoders Will Be Compared"

Many radio amateurs and SWLs are puzzled! Just what are all those strange signals you can hear but not identify on the Short Wave Bands? A few of them such as CW, RTTY, Packet and Amtor you'll know - but what about the many other signals?

There are some well known CW/RTTY Decoders but then there is CODE-3. It's up to you to make the choice, but it will be easy once you see CODE-3. CODE-3 has an exclusive auto-classification module that tells YOU what you're listening to AND automatically sets you up to start decoding. No other decoder can do this on ALL the modes listed below - and most more expensive decoders have no means of identifying ANY received signals! Why spend more money for other decoders with FEWER features? CODE-3 works on any IBM-compatible computer with MS-DOS with at least 640kb of RAM, and a CGA monitor. CODE-3 includes software, a complete audio to digital FSK converter with built-in 115V ac power supply, and a RS-232 cable, ready to use.

CODE-3 is the most sophisticated decoder available for ANY amount of money.

26 Modes included in PROFESSIONAL package include:

- Morse \*
- RTTY/Baudot/Murray \*
- Silor CCIR 625/476-4
- ARQ - Navtex \*
- AX25 Packet \*
- Facsimile all RPM (up to 16 gray shades at 1024 x 768 pixels) \*
- Autospec - Mk's I and II
- DUP-ARQ Artrac \*
- Twinplex \*
- ASCII \*
- ARQ6-90/98
- SI-ARQ/ARQ-S
- SWED-ARQ-ARQ-SWE
- ARQ-N-ARQ1000 Duplex
- Variant
- ARQ-E3-CCIR519
- POL-ARQ 100 Baud
- Duplex ARQ
- TDM242/ARQ-M2/4-242
- TDM342/ARQ-M2/4
- FEC-A FEC100A/FEC101
- FEC-S FEC1000 Simplex
- Sports info 300 baud ASCII \*
- Hellscriber-Synch/Asynch \*
- S tor - RAW (Normal Sitor but without Synch)
- TORG-10/11
- ARQ6-70
- Baudot F788N
- Pactor \*
- WEFAX \*

All modes in typical baud rates with possibility of changing to any desired value of speed and shift. User can save incoming data to disk in either ASCII or raw bit form.

### PROFESSIONAL CODE-3 DECODER

\$595.00 + S & H

Includes: ALL Modes, Plus Oscilloscope\*, ASCII Storage, Auto Classify\*, and PACTOR\* Options

with ALL EXTRA OPTIONS \$795.00 + S&H

### CODE-3 - GOLD VHF/SW DECODER

\$425.00 + S & H

includes POCSAG & ACARS Plus \* Modes/Options

with ALL EXTRA MODES/OPTIONS \$595.00 + S&H

ALSO AVAILABLE - HOKA CODE-3 DSP-based Professional Decoder - CALL FOR PRICE

Now Available - Stridsberg Engineering Multicouplers - "Call for Quantity Pricing" <http://www.scancat.com/mlticplr.html>

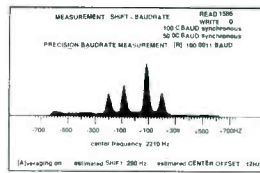

Simulated Speed Measurement Module

#### EXTRA OPTIONS REG. PRICE

Piccolo	\$85.00
Coquelet	\$85.00
4 special ARQ & FEC systems:	
TORG-10/11	
ROU-FEC/RUM-FEC,	
HC-ARQ (ICRC) and	
HNG-FEC	\$115.00
SYNOP decoder	\$85.00

PROsat for Windows users start at about £50.

For more information on all Timestep weather satellite equipment and current prices, you may contact (in the US) Swagur Enterprises at 608-592-7409 phone/fax, email [swagur@execpc.com](mailto:swagur@execpc.com) or visit <http://swagur.com>; or you may write to Timestep at PO Box 2001, Newmarket, CB8 8XB England, or e-mail [Sales@Time-step.com](mailto:Sales@Time-step.com), [www.Time-step.com](http://www.Time-step.com)

## Own Your Own Cellular Site



In author John S. Hollar, Jr.'s own words, "After working many years in commercial antenna site development, I was appalled at how little information is available to the electronic hobbyist, land owner, or real estate community when it comes to the money that can be made from land or buildings which can be offered to the exploding telecommunications industry. So much so, I wrote a book about it."

Do you have a building to support an antenna? Some vacant land? Know where you can find some? *Antenna Site Operating Guide* is a 300+ page book crammed with ideas and information, from using steeples and apartments to marketing and promotional concepts. Also included are lists of equipment needed, along with some good background information on services which would be interested.

*Antenna Site Operating Guide* is available for \$18.95 plus \$3.05 shipping from publisher Hollar Communications, 5201 South Torrey Pines Dr., Suite 1255, Las Vegas, NV 89118-0608; call toll-free 877-877-0040 or email [Jrhollar@aol.com](mailto:Jrhollar@aol.com), or visit <http://members.aol.com/antennas99>

## Shortwave Guide to Southeast Asia

The 36-page *Shortwave Guide to Southeast Asia* is intended to be a single-volume, timely reference for monitoring hobbyists needing accurate and up-to-date information, frequency planners, professional monitoring organizations, media producers, and anyone interested in learning about the impact of shortwave broadcasting on the region. When published in May, it will bring together information unavailable anywhere else.

The *Guide* includes the latest observed domestic shortwave schedules, last summer's comprehensive international broadcast schedules, description of past and current broadcasting operations, geographic and cultural background on the area, QSL policies, and addresses.

The editorial team is comprised of four Australians: Bob Padula, Mick Ogrizek, Craig Tyson, and Matt Francis. The *Guide* may be ordered for US\$10 or 8 International Reply Coupons outside Australia, or A\$10 to Australian addresses. Order before April 30th and receive a special prepublication voucher. Send payment to Bob Padula (Padula Books), 404 Mont Albert Road, Surry Hills, Victoria 3127, Australia; tel/fax +61 3 898 2906; [bpadula@compuserve.com](mailto:bpadula@compuserve.com).

## New Shortwave References for 1999

The name Joerg Klingenfuss has become synonymous with comprehensive shortwave directories. His new, expanded editions are certainly no exception. Let's take a tour of each of these.

**Shortwave Frequency Guide:** Now including both broadcasting and two-way utilities, this massive, 570 page directory lists more than 22,000 worldwide users of the 1.7-30 MHz high frequency spectrum, complete with frequency, identification, loca-

tion, callsign, mode, and pertinent comments. Glossaries and appendices detail frequently encountered abbreviations, listening tips, modulation types, and user profiles. (Available for \$39.95 plus shipping from Grove Enterprises.)

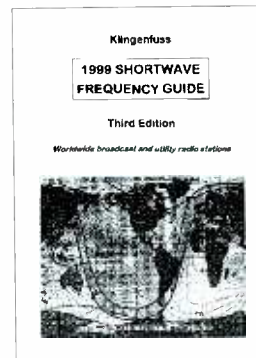

**Guide to Utility Radio Stations:** The two-way signals of the shortwave spectrum are particularly tantalizing, and Klingenfuss details over 11,000 current frequencies and their 1900 users. All modes of transmissions are covered from 50 kHz-30 MHz, along with identifications, locations, callsigns, and network details. Extensive chapters identify callsigns, match users with frequencies, list Q and Z codes, discuss data decoders, and more. (\$49.95 plus shipping from Grove Enterprises.)

**Radiotelex Messages:** "Reading the mail" has always been a popular pastime for those shortwave listening enthusiasts who have demodulators, printers, or computers with appropriate decoding software. *Radiotelex Messages* shows over 1000 messages from historical teletype stations of the past 25 years, as well as current digital communicators to be heard on the global HF spectrum. Arranged alphabetically by country of origin, and including commonly encountered Z and Q codes. (\$49.95 plus shipping from Grove Enterprises.)

**Super Frequency List on CD-ROM:** Essentially a Windows 3.1/95/98 CD version of the *Shortwave Frequency Guide* described above, you can now search by frequency, country, station ID, and callsign for all

records, and even by language and time for broadcasters. Includes abbreviations list and even a digital decoding software program! (\$39.95 plus shipping from Grove Enterprises.)

## Business News

- ComBox, Inc., a wideband internet systems technology company whose SatStream technology we covered in the January issue, now has a U.S. subsidiary located in Annandale, Virginia. To learn more about ComBox, visit their web page at [www.combox-i.com](http://www.combox-i.com), email Senior Vice President Ed Kay at [edkay@combox-i.com](mailto:edkay@combox-i.com), or call 703-333-3008.

- Several years ago, Doug DeMaw gave a rare testimonial in his construction column for CAIG DeoxIT spray for cleaning and deoxidizing electrical connections. The company recently notified us that they have moved. For a catalog of CAIG products, here's the contact info: CAIG Laboratories, 12200 Thatcher Court, Poway, CA 92064-6876; phone 800-CAIG-123; email [caig123@aol.com](mailto:caig123@aol.com) or website [www.caig.com](http://www.caig.com).

- If you're interested in antiques or collectibles, you'll soon be able to shop for them via satellite at Rarities-Exchange.com — a digitally-delivered satellite electronic retailer, television programming service, and internet website. Their corporate office, studio, and fulfillment center will be at 11221 Outlets Drive, Knoxville, Tennessee 37932.

**Books and equipment for announcement or review should be sent to "What's New?" c/o Monitoring Times, P.O. Box 98, 7540 Hwy 64 West, Brasstown, NC 28902**

**Press releases may be faxed to 828-837-2216 or e-mailed to [mteditor@grove-ent.com](mailto:mteditor@grove-ent.com).**



# LETTERS TO THE EDITOR

NEWS AND VIEWS FROM OUR READERS

Rachel Baughn, Editor

## MT Read in High Places

Reader John Maky sent a report to our utility column that an unidentified aircraft on 19131 kHz was heard asking Atlas for frequencies for the Voice of America. Atlas provided them and said the frequencies came out of *Monitoring Times*!

Who is Atlas? A radio operator retired from a related net clarified Atlas's true identity for us. Atlas is the callsign used by Communications Central, Rockwell-Collins, Cedar Rapids, Iowa, when it is in contact with the Drug Enforcement Administration (DEA), with which has a long-standing contract to provide communications.

Utility World previously listed Atlas as being Customs in El Paso, Texas. The DEA does have an El Paso facility known as EPIC (El Paso Intelligence Center), whose callsign is Index 100. Our source said that the facility is seldom on HF any more. In 1994 its existing HF system was disassembled and a Rockwell HF-80 1 kW system installed which is capable of voice privacy systems. Most of the communications via HF between EPIC and the Flint## units (DEA air), Shark units (USCG), Omaha## (US Customs aircraft), Idaho## (FBI) and some of the remote jungle units is through Atlas via phone patch.

## Reviewing a Review

In January, Bob Grove referred to the Alpha Delta VRC Speaker as being a DSP audio processor. Greg Doerschler correctly points out

that it is not. Bob says "My miscue came from Alpha Delta's own ad which compares their product with other DSP products, and their reference to their circuit as a 'sampled data switched capacitance filter.' In modern electronics parlance, sampled data refers to a digital format."

Doerschler also objected to Alpha Delta's ducted port bass reflex speaker system being referred to as a "decent internal speaker." He says, "If testing reveals that the speaker system is indeed nothing more than a 'decent internal speaker,' that finding should be highlighted against the backdrop of Alpha Delta's marketing claims."

Bob replies, in part, "I know speaker systems... Impressive bass emphasis requires more air movement than this small box provides. The fact that it claims to be a 'ducted port bass reflex speaker system' does not make the small enclosure larger, any more than a model airplane can carry a crew and passengers."

"I stand by my very positive review of the Alpha Delta VRC speaker console. While Doerschler criticizes my encapsulated review, we are dealing with restricted-frequency communications enhancement, not CD-quality music reproduction. With the clarification of the switched capacitance filtering rather than DSP, I found the VRC easy to use, razor sharp in its tuning, and capable of decent sound reproduction from its own internal speaker — characteristics not universally shared by competitive DSP products."

I agree, as an editor, that reviews which compare advertising claims with product per-

formance are of the greatest interest to potential buyers. However, we're unable to provide that kind of labor-intensive, in-depth review for most products. The kind of review which provides an overview of the primary features of the product (usually an accessory) plus some initial impressions is a legitimate use of the term "review," though no one would argue that it's the same as a total bench test.

## AirNav software

"I read with a certain joy that you mentioned the existence of AirNav, an airplane tracking system (in February *What's New*, and March *Computers & Radio*). Their URL has changed to: [www.airnavsystems.com](http://www.airnavsystems.com).

"This software is not that difficult to use. The demos included in the software give you in a couple of hours the necessary tips and tricks to use the software in the best possible conditions. The most difficult part is to get used to the aero lingo used by the different air traffic controllers in the world.

"I use this software extensively, and I have learned more about radio propagation, aero comms and some navigational procedures than while hamming 20 years and flying 28 years for a major Belgian airline as a flight attendant!  
— Eric Langhendries ON7LE/KA3WII (retired SABENA F/A)

Reader feedback is always welcome at P.O. Box 98, Brasstown, NC 28902 or via email to [mteditor@grove-ent.com](mailto:mteditor@grove-ent.com).

"Privacy" Bill, continued from page 3

## A Call to Action: Write Now!

So what should you write to your Senators? Ask them to remember their promise to deliver less government instead of more. Ask them to give the FCC enough resources to uphold the laws that are already on the books. Ask them to enquire of the providers what they are doing to

ensure the privacy of their customers. Remember, encrypted communications are already protected by existing law.

Remind them of the great service provided to their country and communities by scanner-equipped public service volunteers, ham radio operators, firefighters, and private citizens. These volunteers, as well as many fire and police departments with low budgets, will be out of the loop if their county agencies move to

a digital system. A digital scanner could make the difference, if Congress doesn't try to micromanage scanner technology and spectrum issues.

It is already quite clear in the U.S. Code that most oral, wire, and electronic communications are off-limits to all but authorized users: it should be left to the spectrum managers and radio engineers to determine how such privacy may be accomplished.

## WRITE NOW

If you don't know who the Senators from your state are, check your local telephone directory or your library. If you're on the Internet, just check [www.senate.gov](http://www.senate.gov) and click on your state. Be sure to send a copy to the Senators on the **U.S. Senate Commerce, Science, and Transportation Committee**:

### Republicans

Spencer Abraham, MI; John Ashcroft, MO; Sam Brownback, KS; Conrad Burns, MT; William Frist, TN; Slade Gorton, WA; Kay Bailey Hutchison, TX; Trent Lott, MS; John McCain, AZ; Olympia Snowe, ME; and Ted Stevens, AK

### Democrats

John Breaux, LA; Richard Bryan, NV; Byron Dorgan, ND; Ernest Hollings, SC; Daniel Inouye, HI; John Kerry, MA; John Rockefeller, WV; and Ron Wyden, OR.

# STOCK EXCHANGE

Monitoring Times assumes no responsibility for misrepresented merchandise.

Ads for **Stock Exchange** must be received 45 days prior to publication date. All ads must be paid in advance to *Monitoring Times*. Ad copy must be typed for legibility.

**NON-COMMERCIAL SUBSCRIBER RATES:** \$.25 per word — *Subscribers only!* All merchandise must be personal and radio-related.

**COMMERCIAL, NON-SUBSCRIBER, AND MULTIPLE SALES RATES:** \$1.00 per word. Commercial line ads printed in bold type.

**1-3/4" SQUARE DISPLAY AD:** \$50 per issue if camera-ready copy or, \$85 if copy to be typeset. Photo-reduction \$5 additional charge. For more information on commercial ads, contact Beth Leinbach. 828-389-4007.

**SHORTWAVE BROADCASTERS—NEWS SERVICES—GOVERNMENT AGENCIES** You can easily control MF-HF-VHF-UHF receivers and transceivers worldwide with the Radphone 2000DX from [www.pca.cc](http://www.pca.cc) Phone +61-2-98889777 Fax +61-2-98050253

**MAHLON LOOMIS, INVENTOR OF RADIO**, by Thomas Appleby. \$25 plus \$5 S/H to SVANHOLM RESEARCH LABORATORIES, PO Box 81, Washington, DC 20044.

**R-390/R-390A/CV-591A SALES & SERVICE. Module Repair to complete Remanufacture.** Info—SASE Rick Mish POB 80041, Toledo, OH 43608. Telefax: 419-255-6220, 9-9 EST.

**ELECTRONIC COMPONENTS. Parts bonanza for manufacturers, engineers, hobbyists.** Thousands of chip capacitors, resistors, transistors, ICs, diodes, plus valuable items such as signal strength meters, LCDs, hardware, much more! All at a fraction of the original cost. Grove Enterprises, Inc., 828-837-9200, [order@grove-ent.com](mailto:order@grove-ent.com)

FOR SALE: ICOM R71A, excellent condition, with remote, all filters, plus speech unit; original boxes, operators manual and service manual; \$700. ICOM R7000, excellent condition, unblocked with operators manual; \$700. AOR AR2500, excellent condition, allmodes, RS232 interface, 1 MHz to 1500 MHz, unblocked; original boxes, manual and power supply; \$350. UNIDEN BC760XLT, excellent condition, unblocked; \$150. UNIDEN 210XW, excellent condition; \$75. YAESU FRG7700 Communication Receiver, good condition; manual; \$150. OPTOELECTRON-ICS COUNTER, 1 MHz to 2.8 GHz; power supply, antenna; excellent condition; \$75. J. Johnson, 757-728-0478 (8pm-12pm Eastern Standard Time).

SWAP: ICOM R7100 unblocked receiver in sealed box with warranty for SONY HR marked monitor or 15x, 4.6"+ field of view binocular or McIntosh 4200 receiver or make other offer. Tel Redg/Fax 310-841-6878.

FOR SALE: JRC NRD-515 receiver with Gilfer mods. 100 kHz-30 MHz with NDH-518 96 channel memory unit, JRC NVA-88 speaker, original manual and boxes. 4 filters: 4.8, 3.4, 2.3, .6 kHz. All in VG or better condition. Too many radios and nowhere to put them all! \$700 plus shipping. Chuck at 440-729-2273 or [N8GMB@AOL.COM](mailto:N8GMB@AOL.COM)

FOR SALE: ICOM R10 handheld scanner, new in box, \$480 money order. Phone or fax Sandy, 412-823-0951.

WANTED: SONY CRF 320-330K-V21 shortwave receivers or PANASONIC RF9000. Please call Gary at 515-278-2581, after 4 pm central time.

## INDEX OF ADVERTISERS

Alinco .....	25
AMSAT .....	65
Antique Radio Classified .....	21
Atlantic Ham Radio .....	17
Boger Electronics .....	81
Communications Electronics .....	29
Computer Aided Technologies .	98, 99
Computer International .....	95
CRB Research .....	15
DX Computing .....	41
FineWare .....	91
Future Scanning Systems .....	27
Glenn Hauser .....	35
Grove Enterprises .. 9, 11, 39, 75, 79,	85, 97
Grundig .....	Center Section
ICOM .....	Cover III
Jacques d'Avignon .....	51
John Figliozzi .....	61
Kevin Carey .....	43
KIWA Electronics .....	31
Klingenfuss .....	65
Monitoring Times .....	103
Motron .....	93
Nil-Jon Antennas .....	5
OptoElectronics .....	Cover II, IV
Popular Communications .....	17
Racing Electronics .....	17
Radiomap .....	93
R.C. Distributing .....	67
RDI White Papers .....	91
Scanner Master .....	95
Skyvision .....	67
Stridsberg Engineering .....	89
Swagur Enterprises .....	65
Universal Electronics .....	63
Universal Radio .....	89
Viking International .....	7
W5YI .....	19
WiNRADiO .....	Between 92&93

### Washington Whispers, continued from page 4

#### Reactions from others

"The devil will be in the details of the proposal," said Pete Tridish of the Prometheus Radio Project located on the Internet at: <http://home.earthlink.net/~prometheusrp>. "We really want to see that spectrum scarcity be handled as much as possible through sharing and promoting access, as opposed to a very few lucky ones who win an auction or lottery."

"We could lose by winning," said Peter Franck of the National Lawyers Guild Committee on Democratic Communications, [www.nlgcdc.org](http://www.nlgcdc.org). "If the FCC moves to legalize micro radio, but then favors commercial applications and auctions of licenses, the thousands of community groups who have waited for access to the airwaves will lose miserably."

"If Low Power FM is proven to critically disable incumbent broadcasters' signals, it should not be implemented," according to Michael Bracy of the Low Power Radio Coalition, [www.lowpowerradio.org](http://www.lowpowerradio.org). "We believe, however, that engineering studies will demonstrate that Low Power FM is a viable mechanism to serve the multitude of voices calling for increased access to broadcast radio."

But, as might be expected, the NAB argues otherwise. "This proposal to add as many as 4,000 lowpower stations to an already congested radio band threatens the transition to IBOC digital radio, will likely cause devastating interference to existing broadcasters, and will challenge the FCC as guardian of the spectrum."



**Join the Club!**

Open to hobbyists worldwide, the **CANADIAN INTERNATIONAL DX CLUB** is Canada's national, general coverage radio club serving members since 1962. The **Messenger** features columns on AM/FM, shortwave, utilities, scanning, QSLing, pirates, ham radio and more. Send \$2 for a sample copy to:

**CIDX**  
 79 Kipps St., Greenfield Park,  
 Quebec, CANADA J4V 3B1  
 e-mail: ve2shw@rac.ca  
 Web: www.anarc.org/cidx/

**Find All of Your Scanner and Shortwave Needs On-Line!**

See Grove's On-Line Catalog at  
<https://www.grove-ent.com/order.html>

**PICTUTOR MICRO-CONTROLLERS**

LEARN HOW TO PROGRAM PICTUTOR MACHINE CODE. 39 EXPERIMENTS DESIGNED FOR USERS AT ALL LEVELS. INTERESTED SEE OUR WEBSITE [HTTP://WWW.SOUTHERN.CO.NZ/PICTUTORNZ/](http://www.southern.co.nz/pictutornz/) OR EAC  
 P.O. BOX 4603 CHRISTCHURCH  
 NEW ZEALAND PH 64-3-366-7386  
 FAX 64-3-366-7886

**Hand-Held Scanners!**

MetroWest is your source for:

Hand-Held Scanners  
 Premium Battery Packs  
 Drop-In Chargers  
 Specialty Antennas  
 Books and More

SEND OR CALL FOR A FREE CATALOG: (708) 354-2125  
 MetroWest, Inc. 822 N. Spring LaGrange Park, IL 60526  
 ORDERS ONLY (800) 657-1475

**"Excellent in all areas!"**

This is just one of the things our readers say about *DX Ontario*, the ODXA's monthly magazine for radio listeners. Get a sample of our 40 page monthly magazine and see for yourself. Only \$3.50. 1999 is our 25th Anniversary!

**Ontario DX Association**  
 Box 161, Station A, Willowdale  
 Ontario M2N 5S8 Canada  
 E-mail: [odxa@compuserve.com](mailto:odxa@compuserve.com)  
 Visit our web site at  
[www.durhamradio.ca/odxa](http://www.durhamradio.ca/odxa)

**R F P I THERMO MUGS**  
 16-oz \$10 each, ppd



**P.O. Box 20728 - M  
 PORTLAND, OR 97220**



**New P3500 V.3 FTA receiver**  
 Fastest Chan lock, best QPSK  
 S-Video, LNB Loopthru, SCART  
 PC upgradable, cable included,  
 UHF modulator out chan. 14-75  
 PID Enforce (even no PMT)  
 \$309 or \$339 w/DiSEqC 4x1  
 877-GO.FEC.1/2, F888-7311384

**Guide To SURVIVAL COMMUNICATIONS**

How to build complete communications systems. Covers shortwave radio, amateur radio, citizens band, scanners, federal, weather, alternate news, satellite radio, equipment sources. How to build alternate emergency power sources, solar, generators, backup batteries. 200 pages. \$24.00 Priority Mail. MC or Visa. Call Universal Electronics 800-241-8171.

**SATELLITE RADIO BOOK & GUIDE**

**NEW BOOK** covers all Audio Services SCPC, Subcarriers, FM<sup>2</sup>, Facsimile Press Services, Weather Services. Simple how-to-receive instructions. **Satellite Radio Guide Included.** \$16.95 plus \$3 Priority Mail (\$19.95 total)

**UNIVERSAL ELECTRONICS, INC.**  
 4555 Groves Road, Suite 12  
 Columbus, OH 43232 (614) 866-4605

**HUGE 100 PAGE CATALOG**

- > Shortwave Receivers
- > Amateur Radio Gear
- > Scanners
- > RTTY & Fax Equipment
- > Books & Accessories

Send \$1 to **Universal Radio**  
 6830 Americana Pkwy. MT  
 Reynoldsburg, OH 43068  
 Tel. 800 431-3939

**Think of what you could do with this space...**

**It's painless, we promise. Contact our advertising manager, Beth Leinbach, at 828-389-4007.**

**Subscribe to MT for as little as \$12.95 (U.S. Second Class Mail)**



Clip and mail this ad along with your payment or call us to subscribe or renew to Monitoring Times!

If you are currently a subscriber to *Monitoring Times*, please check your label to determine the expiration date of your subscription. MasterCard, Visa, and Discover Card accepted!

**\*All payments must be in U.S. Funds drawn on a U.S. Bank!**

	<u>6 months</u>	<u>One Year</u>	<u>Two Years</u>	<u>Three Years</u>
US Rates	<input type="checkbox"/> \$12.95	<input type="checkbox"/> \$23.95	<input type="checkbox"/> \$45.95	<input type="checkbox"/> \$67.95
US 1st Class	<input type="checkbox"/> \$28.45	<input type="checkbox"/> \$54.95	<input type="checkbox"/> \$107.95	<input type="checkbox"/> \$160.95
Canada Surface*	<input type="checkbox"/> \$19.95*	<input type="checkbox"/> \$36.50*	<input type="checkbox"/> \$69.95*	<input type="checkbox"/> \$103.95*
Foreign International*	<input type="checkbox"/> \$28.95*	<input type="checkbox"/> \$55.45*	<input type="checkbox"/> \$108.95*	<input type="checkbox"/> \$162.45*

Grove Enterprises, 7540 Hwy. 64 W., Brasstown, NC 28902; 1-800-438-8155 US and Can.; 828-837-9200; Fax 828- 837-2216; e-mail [order@grove-ent.com](mailto:order@grove-ent.com)

Name \_\_\_\_\_ Address \_\_\_\_\_

City \_\_\_\_\_ State \_\_\_\_\_ Zip \_\_\_\_\_ - \_\_\_\_\_ Country \_\_\_\_\_

CC# \_\_\_\_\_ Exp. Date \_\_\_\_\_

Signature \_\_\_\_\_



By Bob Grove,  
Publisher

## Radio Waves and the Human Body: Two Interesting Views

• A recent item in *Time Digital* (November 30, 1998), sent to me by Chuck Titus of Vancouver, Washington, caught my attention. An Israeli firm, Gen-Epics, claims to have implanted tiny chips in 43 people — perhaps movie stars, political figures, secret agents, or even ultra-wealthy individuals who could be kidnapped — so they can be tracked by satellite. The \$5000 “Sky-Eye” ostensibly is powered by the host’s own “neuro-physiological energy.”

A skeptic might ask: How much nerve power can be tapped from the human body without affecting normal activity? Is this voltage and current enough to reach the avalanche voltage of any active electrical device to sustain oscillation and amplification? What sort of (probably microwave) radiation pattern would be produced by a tiny chip, and how much signal attenuation would the skin produce?

Wouldn't clothing reduce signal strength even further? And what if the individual is in a car, dense woods, a first-floor apartment, or even a cave? What happens to the signal when it rains? How large a satellite antenna is required to detect such a weak signal, and can it discriminate it from the attendant noise? How many satellites are necessary (and from which constellation) to simultaneously monitor 43 or more people worldwide? (Do we sound dubious?)

Perhaps one of our mathematically-inclined readers would like to run the numbers.

• It has been nine years since my article entitled, “Man: The Human Receiver” was published in *MT* (November, 1990). Meanwhile, research has been ongoing to determine the vulnerability of the human body to irradiation from electromagnetic (especially radio frequency) energy. Among these studies, effects of cellular telephone irradiation are quoted the most by the popular press.

Residents near Golden, Colorado’s, Lookout Mountain antenna site are alarmed by the perceived threat of over 400 transmitters in their back yards. Recent measurements show that the radiation is 250% over the maximum allowable federal guidelines.

A recent report published in the *London Times*

(December 31, 1998) carried a large number of tantalizing accounts of apparent bodily damage caused by low level radio exposure; two of these follow:

Dr. Henry Lai, an expert in non-ionizing radiation and a professor at the School of Medicine and College of Engineering and the University of Washington, Seattle, announced that low-level microwave radiation can split DNA molecules in the brains of laboratory mice, an event often associated with Alzheimer’s and Parkinson’s Disease, as well as cancer. Subsequent findings substantiate these results.

But suspicions grow that the Wireless Technology Research grant, supported by the cellular telephone industry, have prevented Lai’s findings from being published. WTR, however, says that their refusal is based upon a lack of professionalism in the writing of the report, and that it is being re-written to bring it up to the level of peer review before publication.

In a parallel study funded by cellular-giant Motorola, conducted by Professor Ross Adey, a radiation biologist, damage to animal tissue from microwave radiation was reportedly observed, but denied by Motorola. Motorola spokesman Norman Sandler says that Adey’s research showed no evidence that mobile phone operation posed a health risk.

In spite of vigorous denials by cellular industrialists, reports of brain tumors and other afflictions among cell phone users are beginning to accumulate worldwide. Many astute journalists are beginning to ask whether they are witnessing another massive cover-up as they recently witnessed with the tobacco industry.

In the Telecommunications Act of 1996, Congress declared that local communities may not refuse to grant cellular or PCS tower construction permits based upon the fear of health risks. To the contrary, Congress is pushing the industry toward a 2005 deadline for completion of two-thirds of needed infrastructure to accommodate hundreds of thousands of users.

Let’s hope what’s good for the economy won’t come back to haunt us. Congress may someday find itself plowing those profits back into research into the health effects of EMF. The issue is far from over.



# Add **MORE** World To Your World Radio

ICOM Wide-Band Receivers Catch **MORE** of the Action

## ▼ IC-PCR1000

*The whole world in a little black box*

100 kHz – 1.300 GHz†

100% PC controlled and hardware external • all mode • unlimited memory channels • real time band scope • DSP\* • includes ICOM software for Windows®, cables, and antenna • download & demo free software from [www.icomamerica.com](http://www.icomamerica.com)



## ▲ IC-R8500

*The expert's choice is also easy to use*

500 kHz – 1.999 GHz†

Commercial grade • all mode • IF-shift • noise blanker • audio peak filter (APF) • 1000 memory channels • built-in CI-V command control and RS-232C port • advanced computer control with ICOM RS-R8500 software for Windows®\*

Longwave. Shortwave. VHF. UHF. Top notch, multiple scan types. From daylight to DC, ICOM receivers do it all in one box.

Please contact your authorized ICOM America dealer today, or call our 24-hour free brochure line: 425-450-6088.

**Also available (L-R):**

**IC-R10** *Advanced listening excitement*

**IC-R2\*** *Excellent audio in a tiny package*

**Both 500 kHz – 1.3 GHz†**



**ICOM**<sup>®</sup>  
[www.icomamerica.com](http://www.icomamerica.com)

†Cellular blocked; unblocked version available only to FCC approved users. \*Optional. ©1998 ICOM America, Inc. 2380 116th Ave NE, Bellevue, WA 98004. 425-454-8155. The ICOM logo is a registered trademark of ICOM, Inc. All specifications are subject to change without notice or obligation. All ICOM radios significantly exceed FCC regulations limiting spurious emissions. FAMRCVR898Y

# CATCH IT. HOLD IT. TUNE IT.

**NEW**

Tuning your receiver will never be easier. Introducing the all new Mini Scout Reaction Tuner. With a .001 second measurement time, the Mini Scout will not miss even the briefest of transmissions. While

locking onto a frequency from up to 200 feet away (5w UHF), the Mini Scout automatically tunes the receiver\* to the action using its patented Reaction Tune capability. No manual tuning necessary.



Patent No. 5,471,402

**Mini Scout  
Reaction Tuner**  
**\$249**

**\*Compatible Receivers:**

**ICOM**  
7000, 7100, 8500, 9000, R10  
**AOR**  
8000, 8000B, 8200  
**Optoelectronics**  
Optocom, R11  
**Radio Shack**  
Pro2005/6 with OS456/Lite  
Pro 2035/42 with OS535

No modifications necessary. Interface cables required.

Specifications	Scout	Mini Scout
10MHz - 1.4GHz	•	•
Reaction Tune	•	•
LCD Display	•	•
<3mV Sensitivity	•	•
Signal Strength Bargraph	•	•
Filter Mode	•	•
Capture Mode	•	•
Backlight	•	•
Beeper	•	•
Vibrator	•	•
400 Memories	•	•
255 Hits Counter	•	•



Patent No. 5,471,402 AR8200 Not Included

**Scout Frequency Recorder  
Reaction Tuner**  
**\$349**



**SPECIAL**  
DB32 & CC30 \$29

Place your  
Order anytime  
at the  
Optoelectronics  
Cyber Store  
[www.optoelectronics.com](http://www.optoelectronics.com)



**Are FM Broadcast  
signals a Problem?**

Knock them out with the N100 Notch Filter. Blocks 88 - 108MHz, Connect between antenna and Scout or Mini Scout.....\$99

**OPTODIRECT • 800-327-5912**

**OPTOELECTRONICS®**

5821 NE 14th Avenue • Ft. Lauderdale, FL 33334  
Phone: (954)-771-2050 Fax: (954)-771-2052 E Mail: [sales@optoelectronics.com](mailto:sales@optoelectronics.com)

Prices and Specifications are subject to change without notice or obligation.  
DB32 Antenna shown on Scout and Mini Scout sold separately. AOR, ICOM, Radio Shack are all registered trademarks