

BULLETIN 79P038

**SERVICE
INSTRUCTIONS
MODEL 79 & 80
WIRE RECORDER**

WEBSTER



CHICAGO

5610 Bloomingdale Ave.

Chicago 39, Ill.

SERVICE INSTRUCTIONS FOR WEBSTER-CHICAGO MODEL 79 & 80 WIRE RECORDER

MODEL 80

The Webster-Chicago Wire Recorder Model 80 is a complete, portable wire recorder and playback unit, consisting of a wire handling mechanism, oscillator, amplifier and speaker, all enclosed in a sturdy, attractive case. Provision is made for using an external speaker or amplifier-speaker (public address system) if desired. Input connections are provided for a microphone or for a high level input, such as a radio tuner or a crystal phonograph pickup. Accessories include a high impedance Crystal Microphone and a Power Cord, stored neatly in a compartment in the cover, also two 15 minute and one 30 minute spools of stainless steel wire mounted on holders in the cover.

Physical Specifications — 17 $\frac{3}{8}$ " x 11 $\frac{5}{8}$ " x 17 $\frac{1}{2}$ ". Weight 27 lbs. complete.

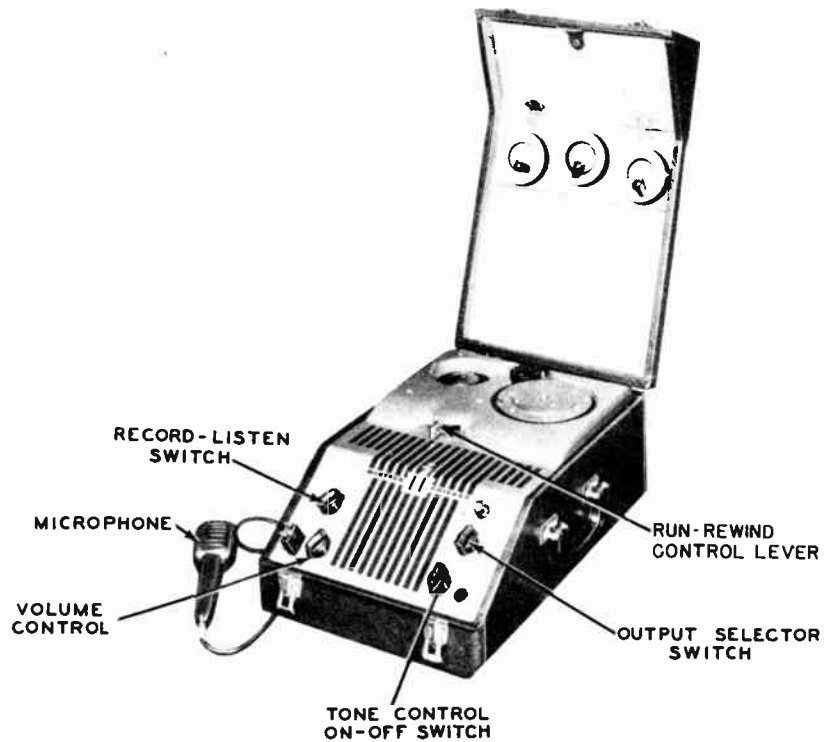

Fig. 1 — MODEL 80 WIRE RECORDER

MODEL 79

The Webster-Chicago Model 79 is a foundation unit, consisting of a complete wire transporting mechanism, a triple-purpose recording head (records, erases and plays back), an oscillator coil, a 15 minute spool of recording wire, and an instruction sheet with suggested circuit diagram. The service information on the Model 79 is identical to the service information on the mechanical portions of the Model 80 as contained in this manual. The unit takes any standard Armour type recording spool and will make continuous recordings up to a full hour. It is not in itself a complete unit, and is supplied to meet the demand for a basic unit by the manufacturer, experimenter, amateur and professional engineer who wishes to build his own wire recorder and player, or to incorporate it in a public address system, radio, etc.

Physical Specifications — 10 $\frac{1}{2}$ " x 8 $\frac{3}{4}$ " x 5 $\frac{1}{2}$ " (3 $\frac{1}{2}$ " below main plate, 2" above.) Net Weight 10 lbs.

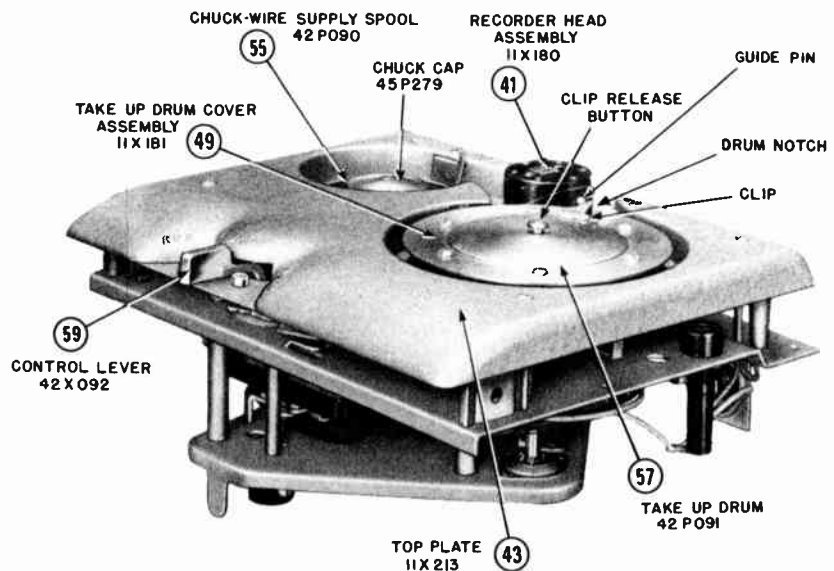

Fig. 2 — MODEL 79 FOUNDATION UNIT



NOTICE TO SERVICE TECHNICIANS

The operating instructions for Models 79 and 80 are contained in the "OPERATING INSTRUCTION MANUAL". The service technician should obtain and study the Operating Instruction Manual before attempting any repairs or adjustments on these units.

INDEX

	Page		Page
I MODEL 79 AND 80 WIRE RECORDER	i	F — Does not record or erase	22
II INDEX	ii	G — Low recording level	22
III MECHANICAL SERVICE NOTES		VI VOLTAGE AND RESISTANCE DATA	23
A — To remove from case — Serial Nos. 5000 to 11000	1	VII MICROPHONES	24
B — To remove from case — Serial Nos. 11000 up	1	VIII REPLACEMENTS PARTS LIST	27-28-29
C — Spools and Head	1	IX CONDENSED FACTORY TEST SPECIFICATIONS	30-31
D — Shaft Settings	1-3	X ILLUSTRATIONS	
E — Recheck Recording Head	3	Fig. 1 — Model 80 Wire Recorder	i
F — Wire fails to "tuck-in"	3	Fig. 2 — Model 79 Foundation Unit	i
G — Wire breaks — end of "rewind"	3	Fig. 3 — Spool height adjustments	2
H — Wire runs too slowly	3	Fig. 4 — Motor position adjustments	4
I — Motor Drive Tension	3-4	Fig. 5 — Motor position adjustments	5
J — Take-up drum will not turn or slips when recording	4	Fig. 6 — Motor position adjustments	5
K — Supply spool will not turn or slips when recording	4	Fig. 7 — Motor suspension adjustments	6
L — Cam and Rocker Arm Assembly	8	Fig. 8 — Motor position settings	6
M — Mechanical rattle in take-up drum	8	Fig. 9 — Motor position settings	6
N — "Wows" and "Flutter"	8	Fig. 10 — Motor position settings	6
O — Fouling of wire	8	Fig. 11 — Rear view — Drive mechanism	7
P — Brakes	9	Fig. 12 — Top view — Drive mechanism	7
Q — Uneven recording speed	9	Fig. 13 — Brakes, Wire pull tension	10
R — Wire spills when recording	9	Fig. 14 — Braking mechanism	11
S — Wire spills when rewinding	9	Fig. 15-16 — Brakes — Run position	12
T — Motor control switch	16	Fig. 17-18 — Brakes — Run to Stop position	13
U — Noise at beginning of recording	16	Fig. 19-20 — Brakes — Rewind position	14
IV LUBRICATION	17	Fig. 21-22 — Brakes — Rewind to Stop position	15
V ELECTRICAL REPAIRS AND ADJUSTMENTS		Fig. 23-24-25 — Control lever switch positions	16
Circuit changes	17-18	Fig. 26 — Amplifier panel — top view	18
A — Will not run	22	Fig. 27 — Amplifier Chassis — bottom view	19
B — Speaker field burned out	22	Fig. 28 — Model 80 Circuit diagram	20
C — Replacing oscillator coil	22	Fig. 29-30 — Record-Listen switch	21
D — Does not record	22	Fig. 31 — Output switch — Position No. 1	21
E — Does not erase	22	Fig. 32 — Mic. plug connections	24
		Fig. 33 — Exploded parts layout	25-26

WARNING

The Webster-Chicago Wire Recorder is designed to operate on 105-120 Volts, 50-60 cycle ALTERNATING CURRENT at a power rating of 65 watts. Best results are obtained when recording and playback are made with the same frequency. With 50 cycle supply, the fidelity will be a little less, since the wire speed will be about 17% less than normal.

NEVER ATTEMPT TO OPERATE THIS RECORDER FROM A DIRECT CURRENT SOURCE OR FROM A FREQUENCY OTHER THAN 50-60 CYCLES.



MECHANICAL SERVICE NOTES

Model 80 Wire Recorders and Model 79 Foundation Unit mechanisms are accurately adjusted, lubricated and tested at the factory. However, adjustments in the field will be necessary if parts are replaced or specific troubles indicate misadjustment. The recommended corrections given should be made only by a qualified radio service technician. Service parts are available from your distributor. All parts must be ordered by part number, model number and serial number, stamped on the name plate.

A—TO REMOVE FROM CASE MODEL 80 — SERIAL Nos. 5000 TO 11000

Remove Top Plate. Place small piece of cardboard under Control Lever (Fig. 1) so panel will not be scratched in removing. Remove knobs (pull off). Remove 2 screws and 4 hex nuts holding panel. Take out the 5 wood screws on each side in order to remove the unit. Entire unit may then be removed from case by lifting straight up. **DO NOT TAKE OUT COUPLING SCREWS.** The coupling screws are the two hexagon screws on each side that hold the Mechanical unit to the Electrical unit. After the entire unit has been removed from the case, these screws may be removed if it is desired to separate the Mechanical unit from the Electrical Unit.

B—TO REMOVE FROM CASE MODEL 80 — SERIAL Nos. 11000 UP

Remove four screws from the bottom of the case and one from each side. This permits easy removal of the entire chassis assembly. The sled type construction protects all working parts during service operations.

C—SPOOLS AND HEAD

If wire spills over the top or bottom of both the take-up drum and the supply spool when recording or rewinding, adjust the stroke of the recording head by means of the recording head adjusting screw (illustration 80, Fig. 11). This screw is reached by removing the top cover (Fig. 2) and inserting a screw driver through the small hole shown in Fig. 11.

D—SHAFT ADJUSTMENTS

If wire spills over the top or bottom on only the Drum or the Supply Spool, adjust the proper shaft.

To adjust the height of the Take-up Drum or Supply Spool shaft, follow the instructions of Fig. 3. Be sure that there is proper clearance between the collar and the main plate.

Wire recorders (Serial Nos. 5000 — 11000) may be adjusted through the holes provided in the bottom of the case. Use care in mak-



ADJUSTMENTS FOR TAKE-UP DRUM AND SUPPLY SPOOL CHUCK

Second. Place spool of wire firmly on Rewind Chuck. Line up the inside of the Bottom Flange with the inside of the Bottom Flange of the Take-up Drum.

Third. Set Recording Head Groove so wire will wind Flush with the inside of the Bottom Flanges of Rewind Chuck and Take-up Drum.

First. Set inside of Flange Flush to 1/32" higher than Top Plate.

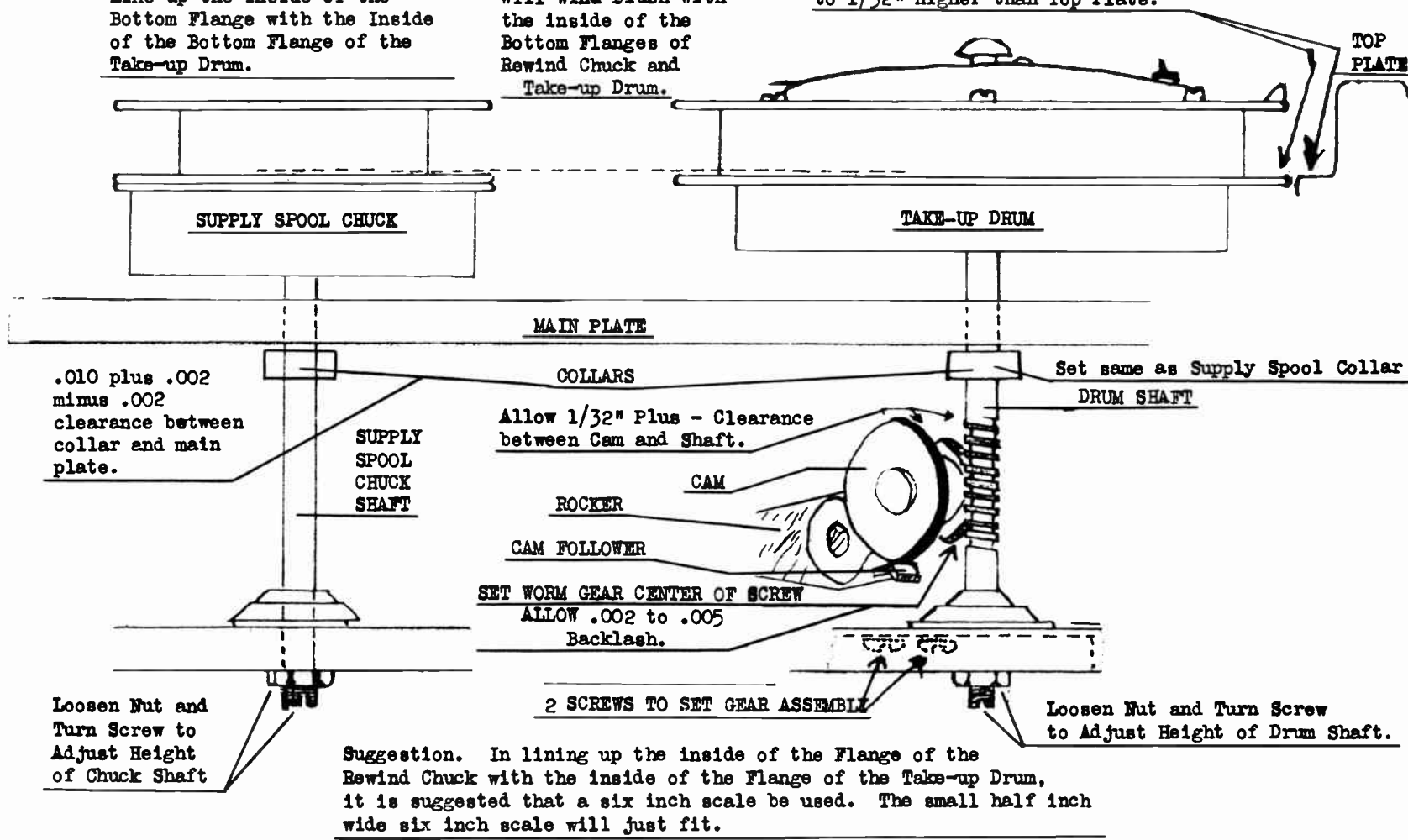

.010 plus .002 minus .002 clearance between collar and main plate.

SUPPLY SPOOL CHUCK SHAFT

Allow 1/32" Plus - Clearance between Cam and Shaft.

Set same as Supply Spool Collar DRUM SHAFT

SET WORM GEAR CENTER OF SCREW ALLOW .002 to .005 Backlash.

Loosen Nut and Turn Screw to Adjust Height of Chuck Shaft

Loosen Nut and Turn Screw to Adjust Height of Drum Shaft.

Suggestion. In lining up the inside of the Flange of the Rewind Chuck with the inside of the Flange of the Take-up Drum, it is suggested that a six inch scale be used. The small half inch wide six inch scale will just fit.

Fig. 3 — SPOOL HEIGHT ADJUSTMENTS



ing these adjustments in order that the wire will wind evenly across the hub of the Take-up Drum or the Supply Spool. The more even and smooth the wire is wound, the less danger there will be of spillage. Also wire wound improperly will cause "Wows" and/or "Flutter"

E — RECHECK RECORDING HEAD

Recheck the height of the stroke of the recording head after these adjustments. The groove in the recording head should travel almost even with the bottom flange of the take-up drum and spool chuck each cycle.

F — WIRE FAILS TO "TUCK-IN" ON THE SUPPLY SPOOL AT THE END OF REWIND

The wire clip on the take-up drum cover (Fig. 2) is set to give a little jerk as the last turn of wire leaves the spool during "Rewind". This jerk causes the last turn to tuck into the lower layers of wire on the supply spool and prevents unravelling. If the tension is too weak, the wire will not be held and this tucking will not take place. The tension of the clip is adjusted by turning the adjusting screw (Fig. 2). On a few units this tension is adjusted by turning the nut. It is necessary to remove the take-up drum cover (Fig. 2) to make this latter adjustment.

G — WIRE BREAKS AT THE END OF "REWIND"

Too much tension on the clip mentioned in

"F" may cause consistent breaking of the wire at the end of the rewind. Occasional breaking at the clip is normal, due to kinking near the end of the wire. Since only a fraction of a second of recording time is lost with each break no harm is done. See paragraph "F" for tension adjustment.

H — WIRE RUNS TOO SLOWLY

Grime may accumulate in the slot of the recording head (Fig. 2). Dirty or gummy wire, due to handling, will cause the recording head to become gummy. This not only will cause the wire to pull hard through the recording head but will in some cases act as an insulator and cause "WOWS". Use a fine stiff brush (toothbrush) dipped in carbon-tetrachloride to clean the groove.

STAINLESS STEEL WIRE DOES NOT NEED OIL OR GREASE ON IT

I — MOTOR DRIVE TENSION

With the motor control lever in "Run" position, the motor shaft should press against the idler wheel (Fig. 8) firmly but not too tightly. From 7 to 9 oz. pressure.

The energy from the motor is shifted from the "Supply Spool" to the "Take-up Drum" by actually shifting the position of the motor. This is accomplished by means of the motor

control lever (Fig. 2) operating on a cam attached to the motor control lever.

J — TAKE-UP DRUM WILL NOT TURN OR SLIPS WHEN RECORDING

Increase pressure of motor shaft against the idler wheel (Fig. 10) by bending cam followers. (Figs. 4, 5, 6).

K — SUPPLY SPOOL WILL NOT TURN OR SLIPS WHEN REWINDING WIRE

Increase pressure of motor shaft against the take-up wheel by bending the cam followers. (Figs. 4, 5, 6, 10).

Adjustments can best be made by use of a slotted bar.

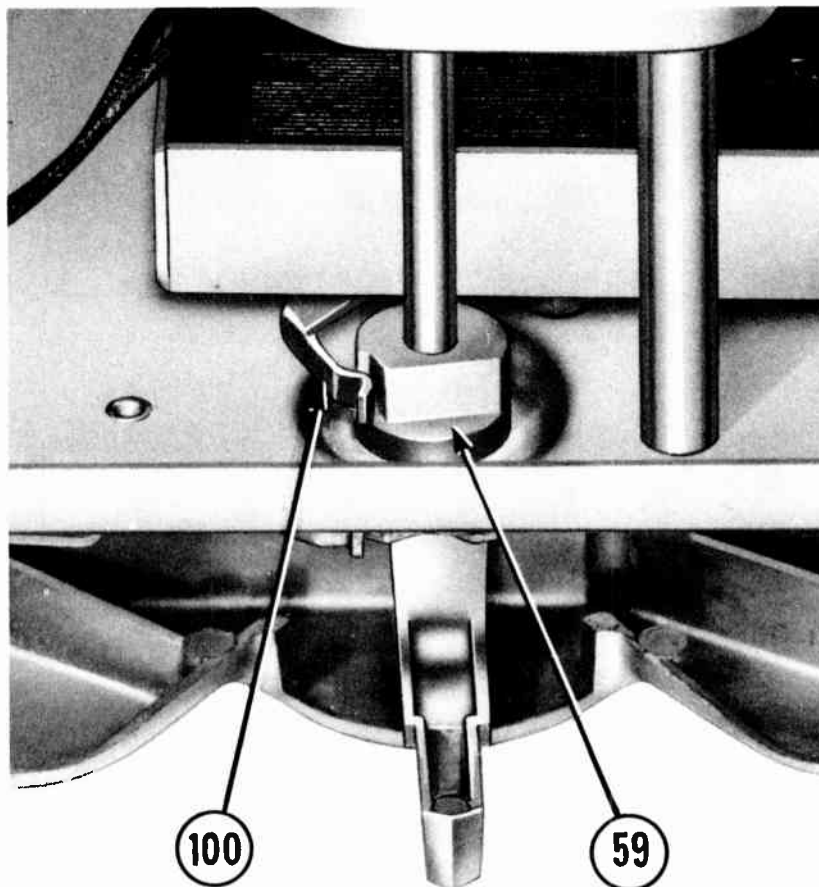

Fig. 4 — MOTOR POSITION ADJUSTMENT

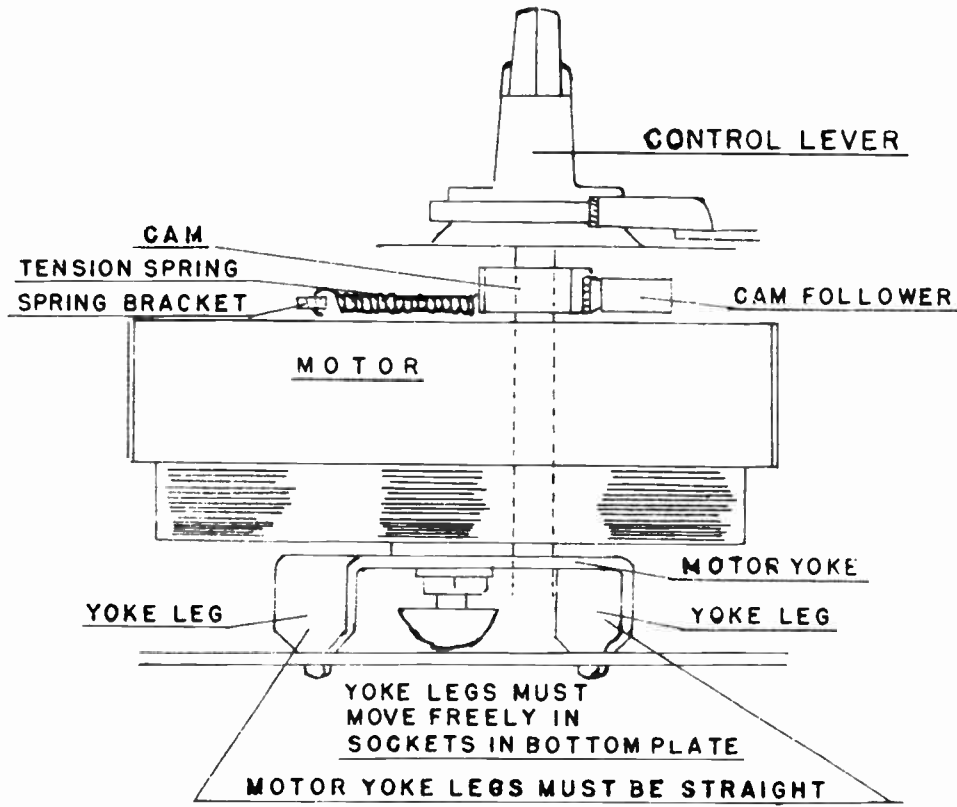

Fig. 5 — MOTOR POSITION ADJUSTMENTS

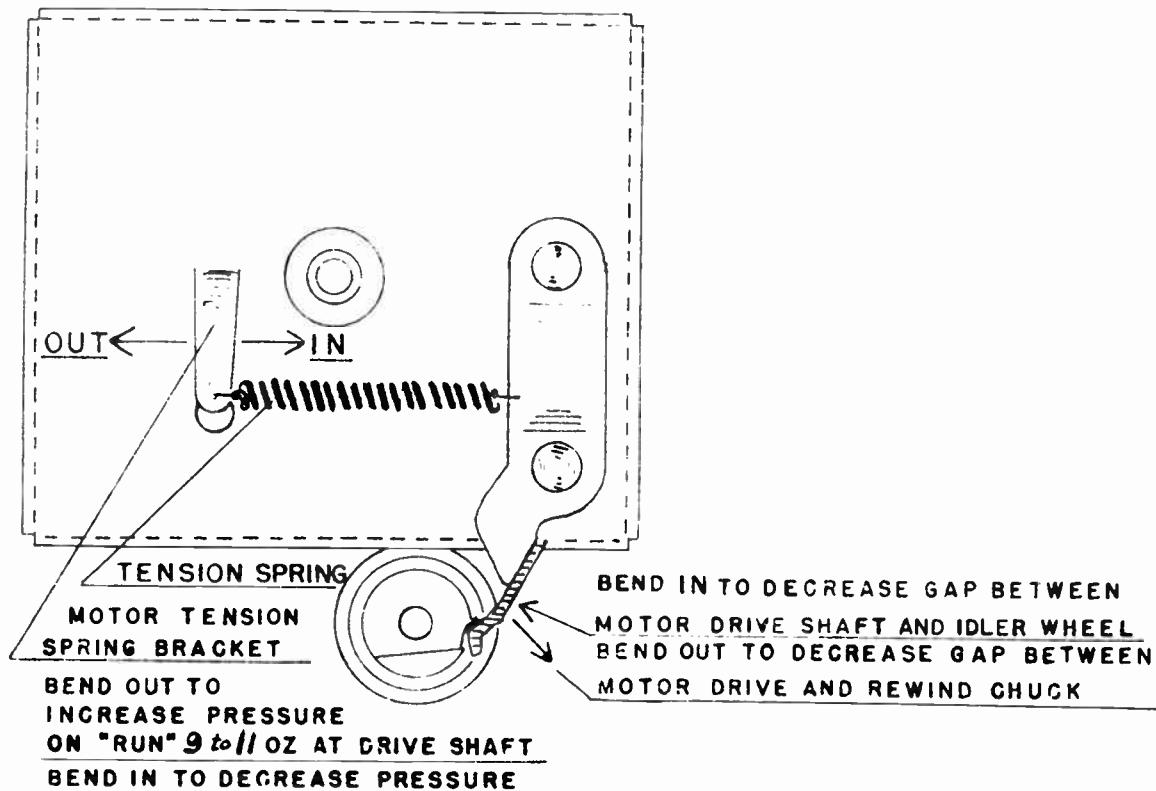

Fig. 6 — MOTOR POSITION ADJUSTMENT

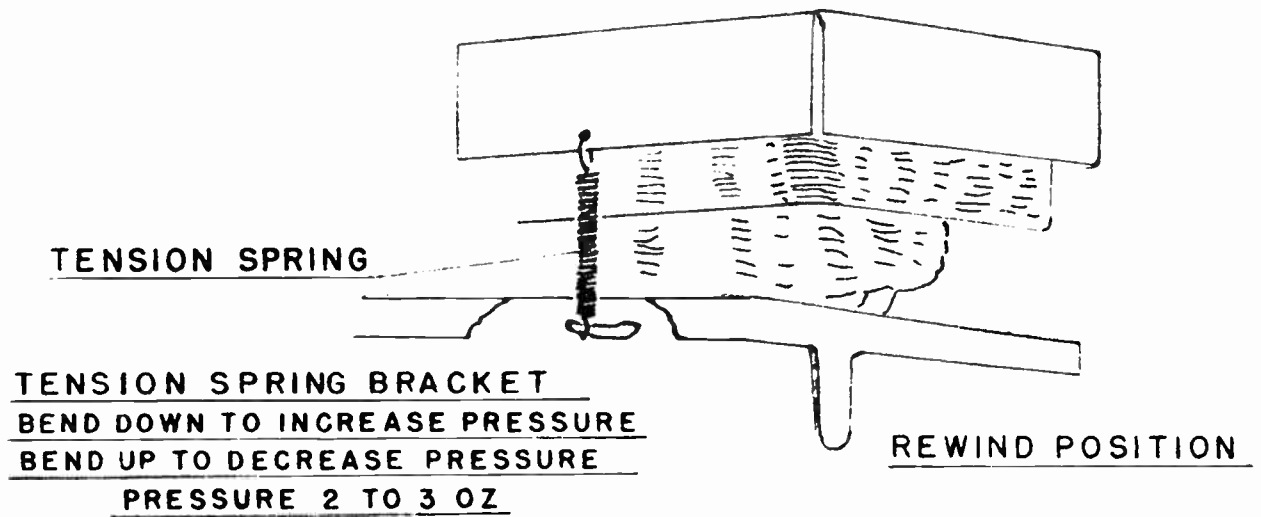

Fig. 7 — MOTOR SUSPENSION ADJUSTMENT

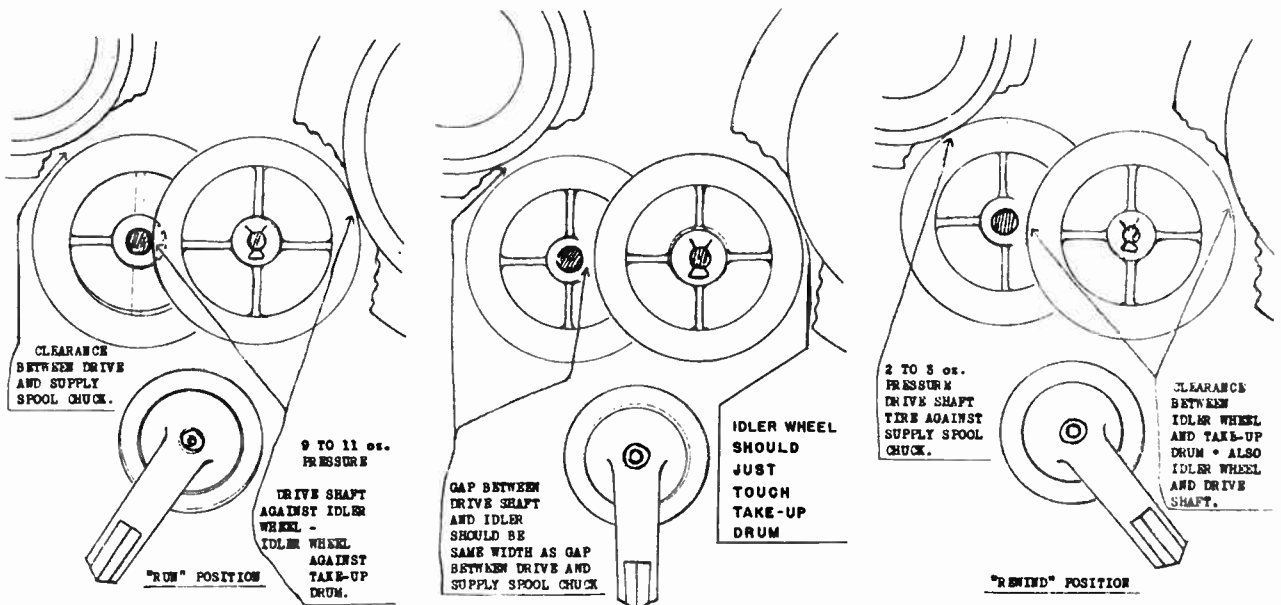

Fig. 8

Fig. 9

Fig. 10

CORRECT MOTOR-PULLEY POSITIONS

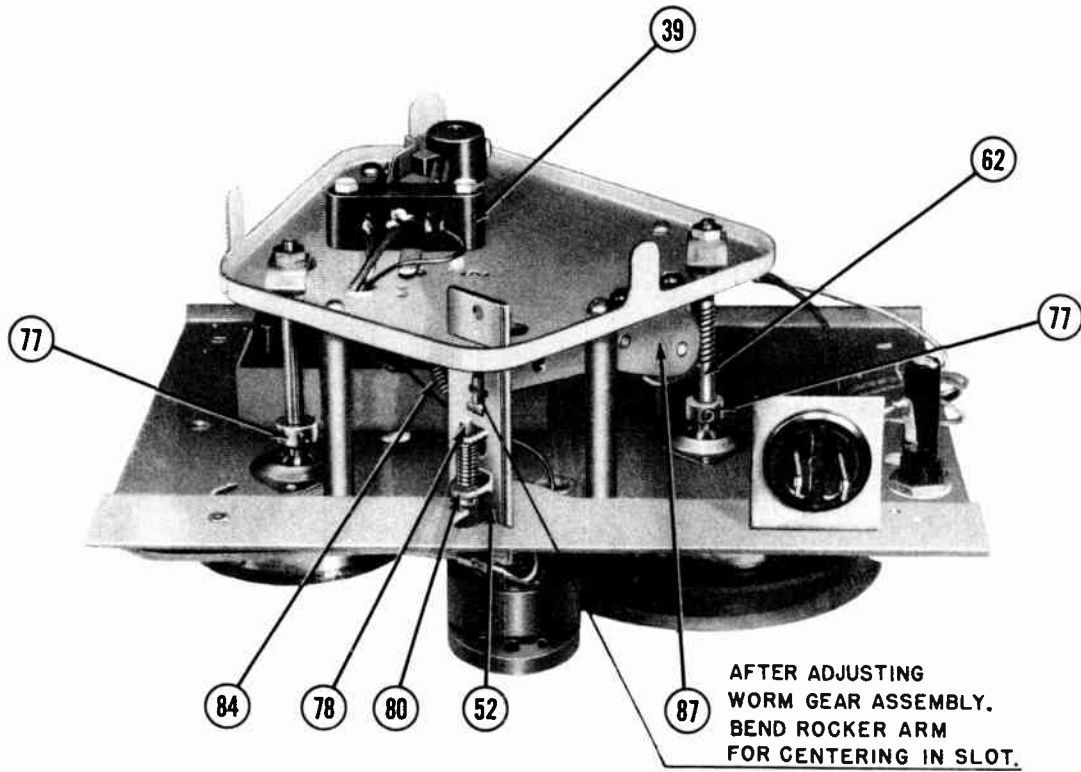

Fig. 11 — REAR VIEW — DRIVE MECHANISM

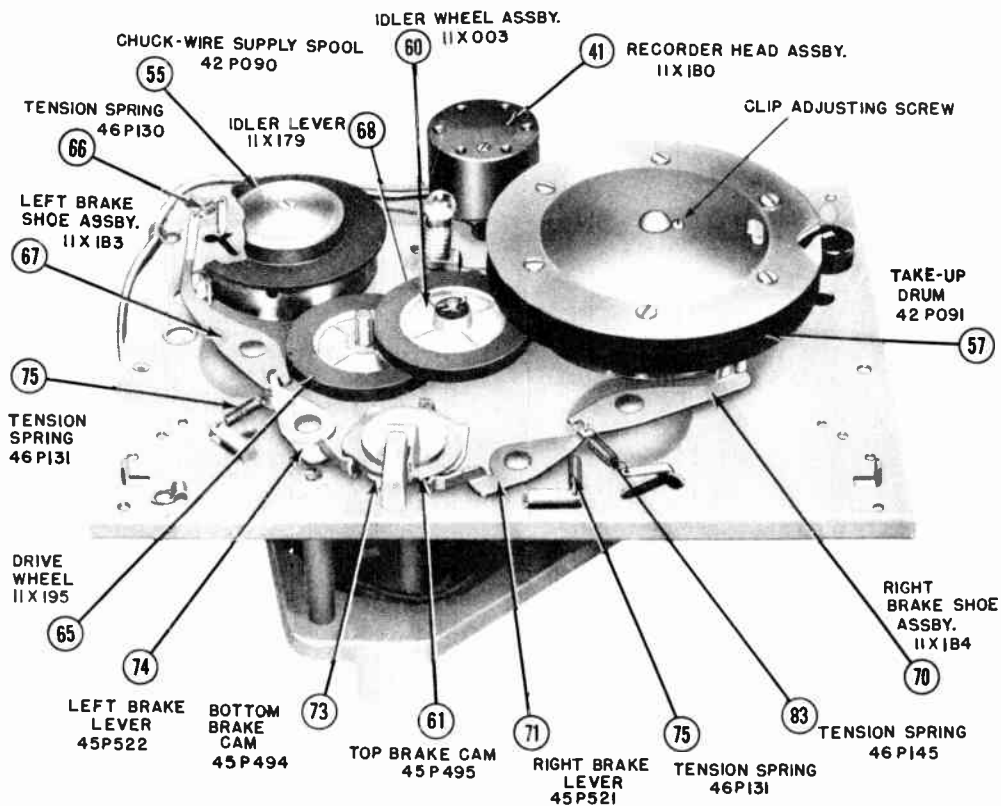

Fig. 12 — TOP VIEW — DRIVE MECHANISM (Less Cover Plate)



L — CAM AND ROCKER ARM ASSEMBLY — Mechanical Noise and Vibration

Check the adjustment of the cam and rocker arm assembly (Illustration 87, Fig. 11) against the take-up wheel drive post (Illustration 62, Fig. 11). Back lash should be .002 to .005. If greater, loosen screws (Fig. 11) and re-set. If the gear is loose on the rocker arm, replace the entire assembly.

M—MECHANICAL RATTLE IN TAKE-UP DRUM

The push button in the center of the take-up drum may be loose. Remove the drum top and solder the push button to the wire clip lever.

N — "WOWS" AND "FLUTTER"

The most common reason for "wows" is failure to phase the wire. Always start the wire with recording head at the top of its travel. Be sure that there is nothing which will rub against either the take-up drum or the supply spool.

Check the wire on the supply spool to see that it is not wound too tightly. See that the recording head is moving up and down smoothly, that slide has not been bent.

See that no grease or oil has been permitted to get on the drive wheel tire (Illustration 65, Fig. 14) or the idler wheel (Illustration 60, Fig. 14) or the take-up drum (Illustration 57, Fig. 14). Any oil or grease at these points will cause slippage, which in turn is transferred to "wow". Clean thoroughly with carbon-tetrachloride. "Flutter" may be caused by roughness in part of the driving train such as scoring of the take-up drum with a sharp instrument in removing spilled wire. Excessive vibration is usually due to getting something out of alignment, causing "flutter". "Flutter" is very rare and occurs only when unusually rough treatment has been given the wire recorder.

O—FOULING OF WIRE

Carelessness is responsible for nearly all fouling of wire. Should the wire on the take-up drum or supply spool become very loose, or fouled badly, cut through the bight, or where it bellies, and carefully take off the wire in the reverse direction in which it is wound on either the supply spool or the take-up drum.

When the wire has been allowed to get under the take-up drum, cut the wire so that the supply spool may be removed, remove



the cover, carefully cut wire fouled around brake, brackets or drum and carefully remove, unwinding counter clockwise or contrary to the direction in which it is wound. DO NOT pull wire when it is caught on anything as damage may be done to the mechanism.

Where the wire has been allowed to get under the chuck of the wire supply spool, cut the wire where it goes under, remove the supply spool, remove the cover, carefully cut the wire or wires that may be around the chuck and remove.

P — BRAKES

A "memory" brake system to control the feeding of the wire is tied in with the control lever (Illustration 59, Fig. 14). When this lever is moved from its "Stop" position to its "Run" position, a light brake is applied to the supply chuck (Illustrations 55 and 18, Figs. 14, 15, 16). When the control lever is returned to the "Stop" position, a heavy brake is applied to the same chuck and a light brake applied to the take-up drum. (See Figs. 17, 18).

When the lever is moved to "Rewind" the brake is removed from the supply chuck and a light brake is applied to the take-up drum. (Figs. 19, 20). Returning it to "Stop" applies

a heavy brake to the take-up drum and a light brake to the rewind chuck. (Figs. 21, 22).

Q—UNEVEN SPEED IN RECORDING

With the control lever in the "Run" position, check the brake adjustment on the supply chuck. (Fig. 13). If the tension is too heavy, the wire will feed too slowly with resulting slow speed.

To adjust the brake, bend the base plate lug to which the tension spring (Figs. 14, 15, 16) is attached. In extreme cases, slightly bend the brake lever (Illustration 74, Fig. 14). When properly adjusted, the upright flange of the left brake lever (74) should be approximately centered in the slot of the left brake shoe assembly. (67), Fig. 14.

R—WIRE FEEDS TOO FAST AND SPILLS WHEN RECORDING

This indicates insufficient brake tension on the supply spool, permitting it to overrun the take-up drum. Adjust as explained in Figs. 15, 16.

S—WIRE FEEDS TOO FAST AND SPILLS WHEN REWINDING

This indicates insufficient brake tension on the take-up drum. Adjust brake on take-up drum. (Figs. 19, 20).

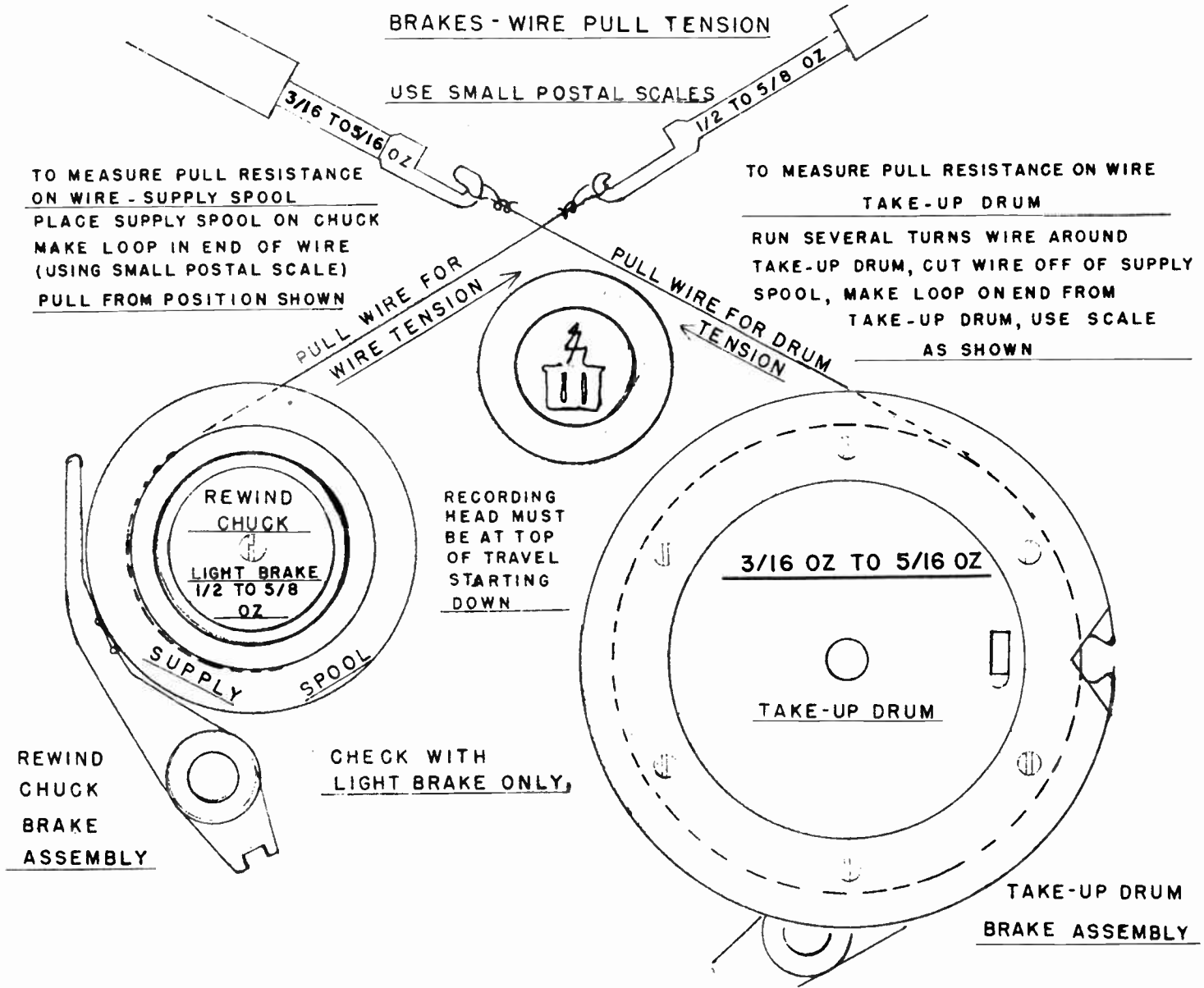

10

Fig. 13 — BRAKES — WIRE PULL ADJUSTMENT

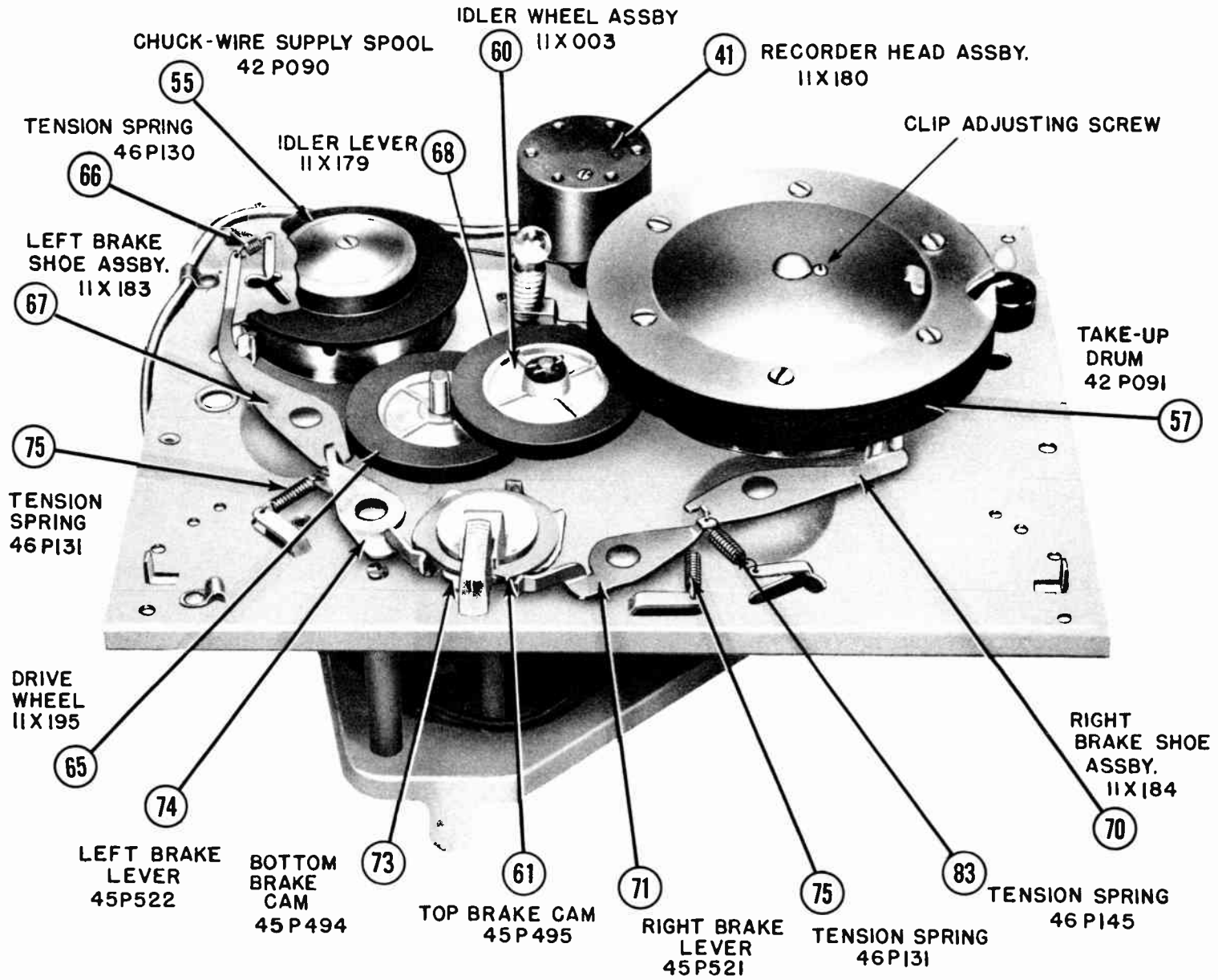

Fig. 14 — BRAKING MECHANISM

BRAKES
RUN POSITION

SERIAL NOS. 5000 TO 17000

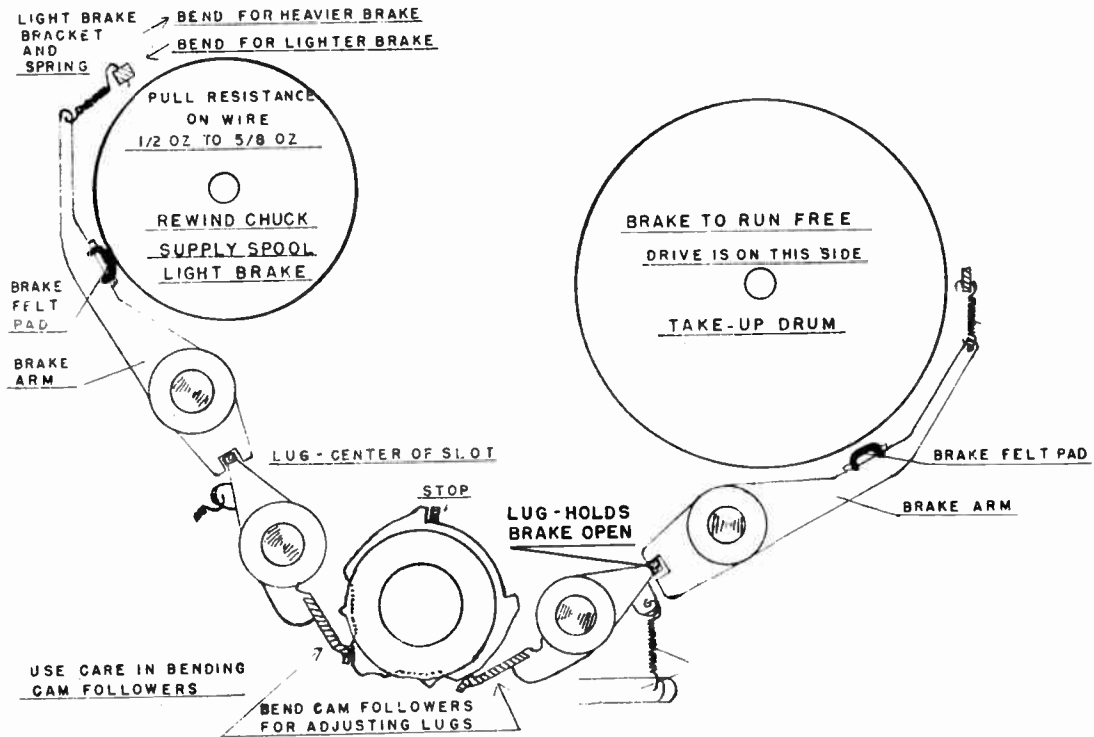

Fig. 15 — BRAKES — RUN POSITION (SERIAL Nos. 5000 TO 17000)

BRAKES
RUN POSITION

SERIAL NOS. 17000 UP

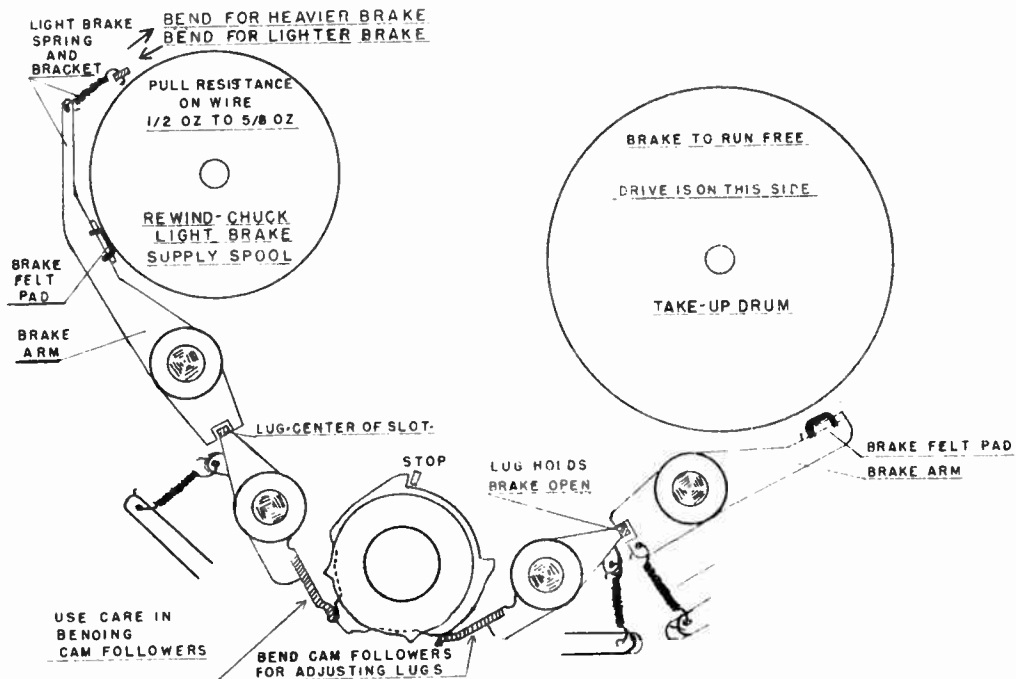

Fig. 16 — BRAKES — RUN POSITION (SERIAL Nos. 17000 — UP)

BRAKES

RUN TO STOP SERIAL NOS. 5000 TO 17000

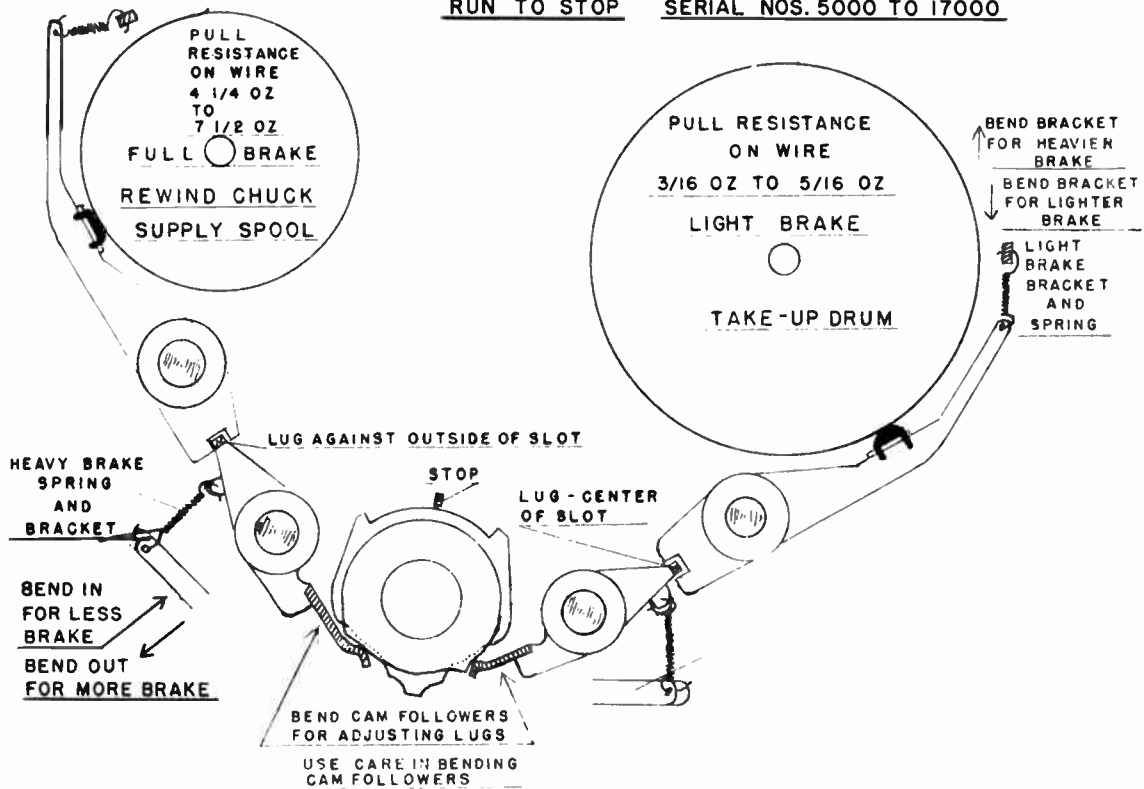

Fig. 17 — BRAKES — RUN TO STOP (SERIAL Nos. 5000 TO 17000)

BRAKES

RUN TO STOP - SERIAL NOS. 17000 UP.

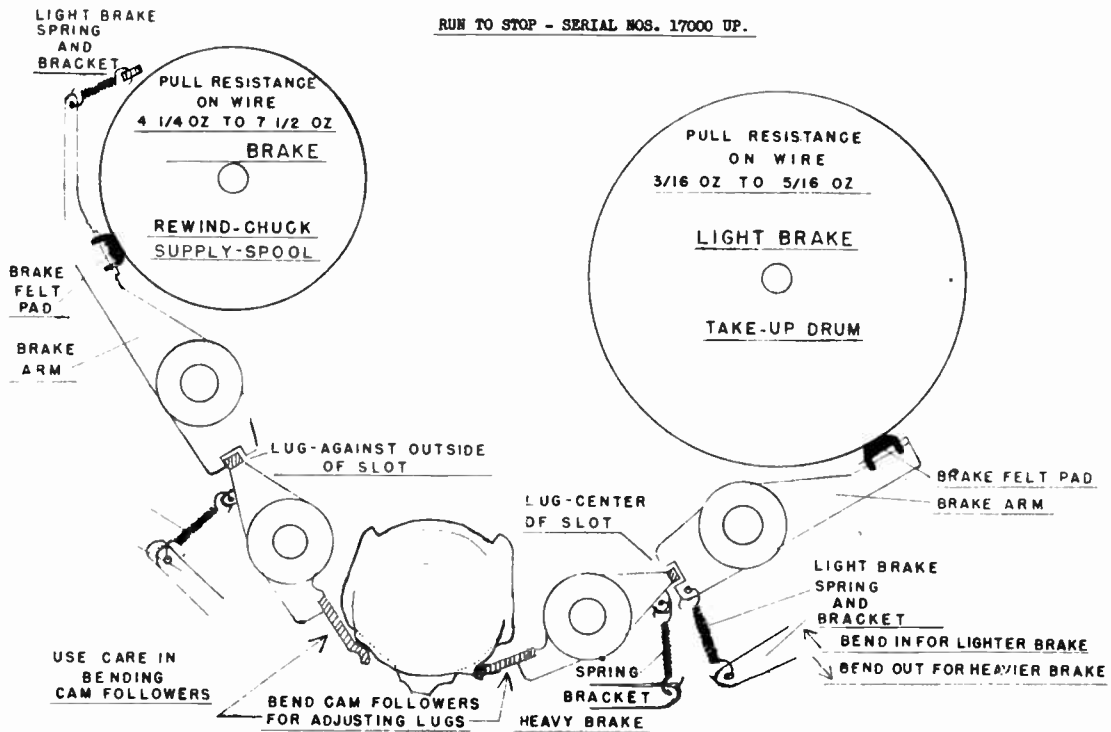

Fig. 18 — BRAKES — RUN TO STOP (SERIAL Nos. 17000 — UP)

BRAKES
REWIND

SERIAL NOS. 5000 TO 17000

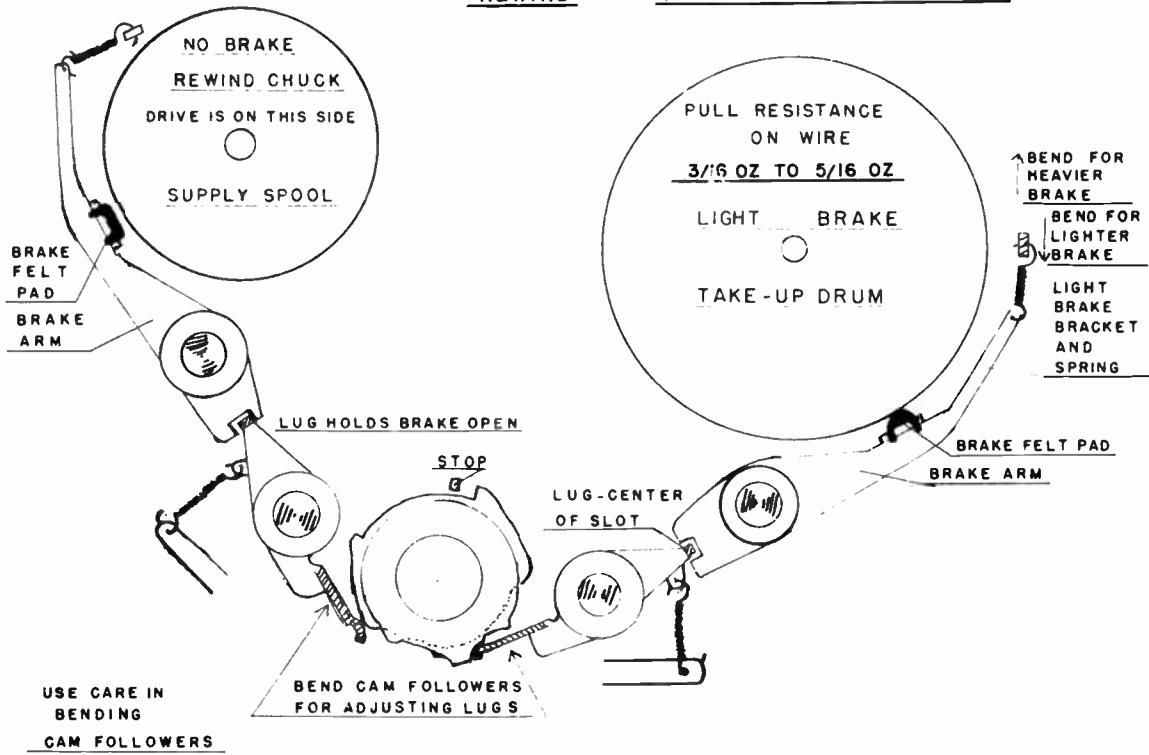

Fig. 19 — BRAKES — REWIND (SERIAL Nos. 5000 TO 17000)

BRAKES
REWIND

SERIAL NOS. 17000 UP

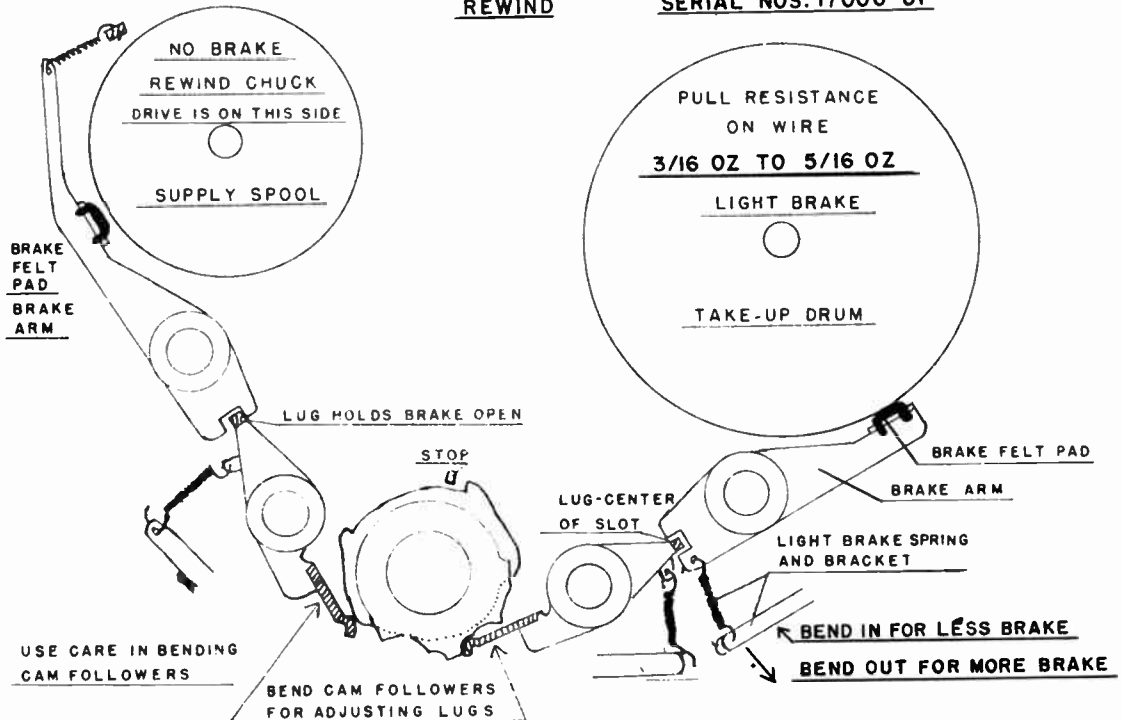

Fig. 20 — BRAKES — REWIND (SERIAL Nos. 17000 — UP)

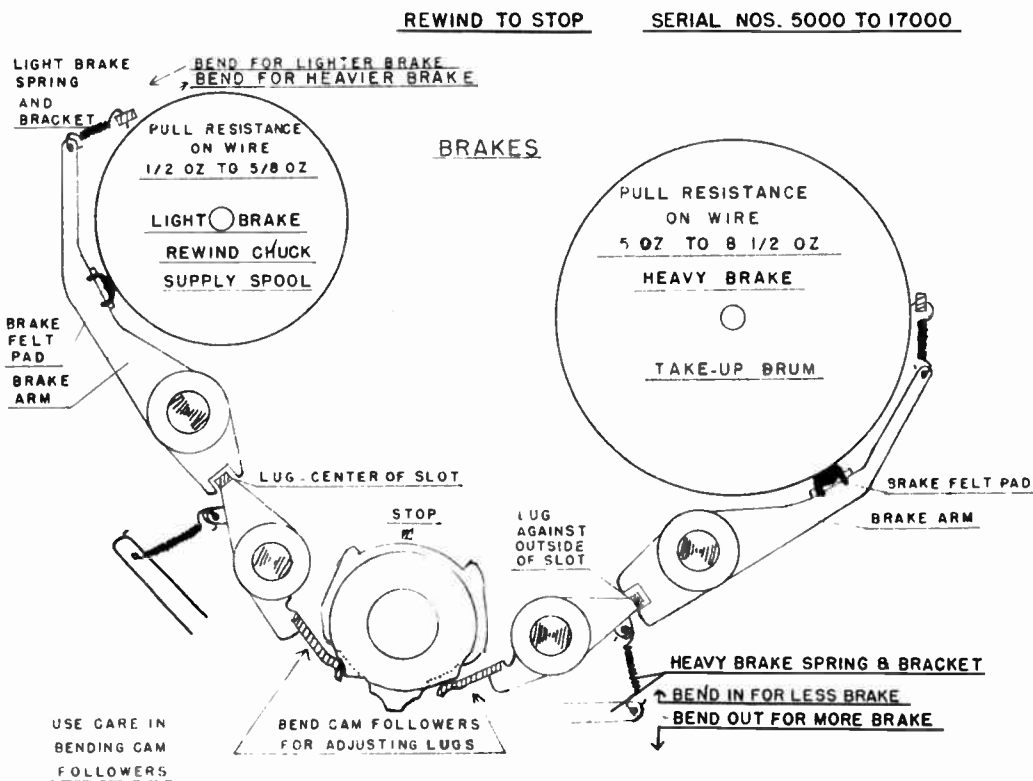

Fig. 21 — BRAKES — REWIND TO STOP (SERIAL Nos. 5000 TO 17000)

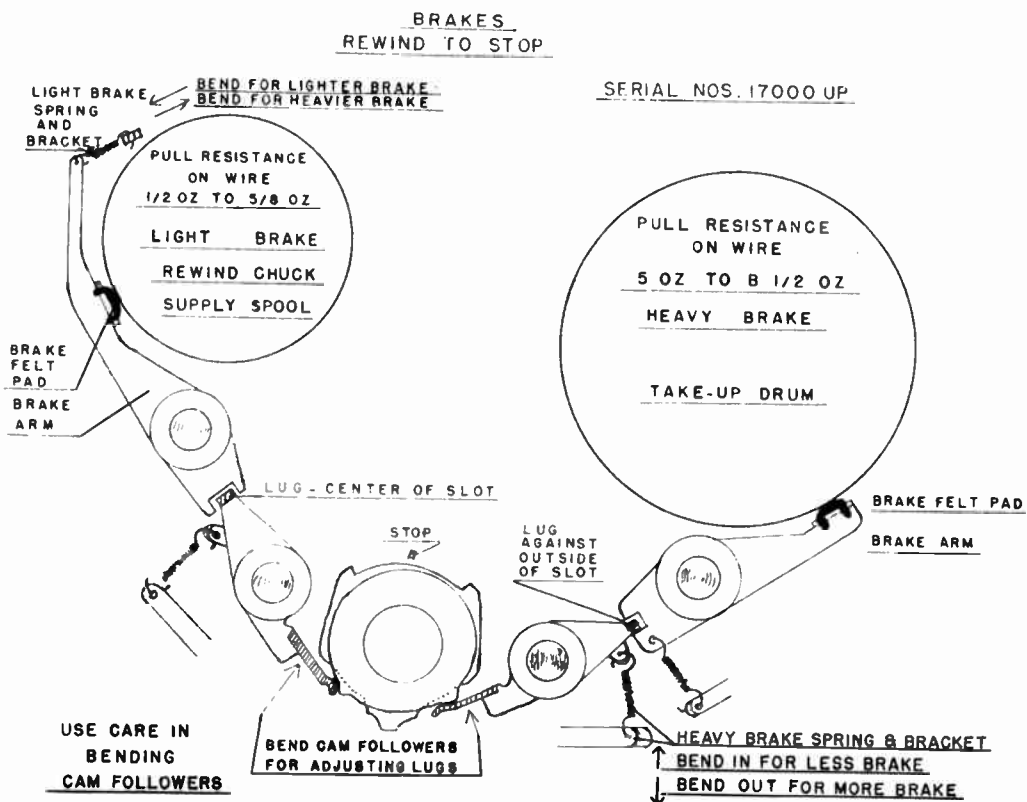

Fig. 22 — BRAKES — REWIND TO STOP (SERIAL Nos. 17000 — UP)



T — MOTOR CONTROL SWITCH

With the motor control lever in "Stop" position, the switch contacts should both be open $\frac{1}{32}$ " to $\frac{1}{16}$ ". When the lever is moved to "Run" position the motor contacts (Fig. 24) should be first to close. In "Rewind" position the recording head contacts (Fig. 25) should remain open.

U — NOISE AT BEGINNING OF EACH RECORDING SEQUENCE

If the recording head contacts close before the motor contacts, the noise of making contact and starting will appear on the wire. Bend the switch contacts (Illustrations 72, 76) so that the motor starts before the recording head is energized.

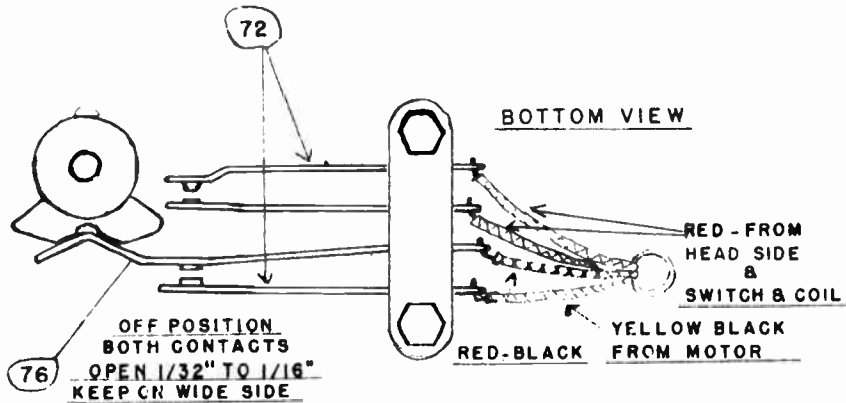

Fig. 23 — MOTOR CONTROL SWITCH — "OFF" POSITION

SET CONTACTS SO VIBRATION WILL NOT AFFECT OPERATION OF SWITCH
BE SURE CONTACTS ARE SET SO MOTOR IS RUNNING BEFORE MOTOR
DRIVE SHAFT CONNECTS WITH IDLER WHEEL OR SPOOL CHUCK

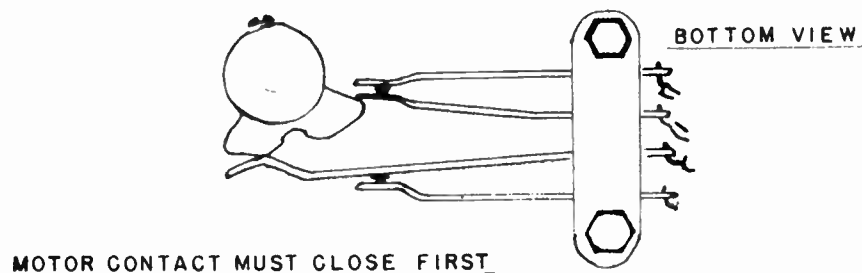

Fig. 24 — MOTOR CONTROL SWITCH — "RUN" POSITION

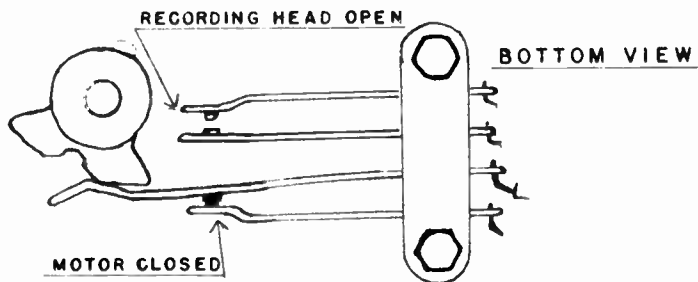

Fig. 25 — MOTOR CONTROL SWITCH — "REWIND" POSITION



LUBRICATION

It is well to lubricate about every six months, or for every 500 hours of operation. Use a grease, such as Lubriplate, at the following points.

- 1 — Sliding surfaces or slide and socket assembly. (Illustration 52, Fig. 11).
- 2 — Sliding surfaces of brake cams (Illustrations 61 and 73, Fig. 14) and control lever (Fig. 11). Be sure to grease the edges of the cams where they rub against the brake levers. (Illustrations 71 and 73, Fig. 14).
- 3 — Pivots of brake control levers (Illustrations 71 and 73, Fig. 14) and brake shoe assemblies (Illustrations 67 and 70, Fig. 14). Do not use grease in the slots of the brake shoe assemblies.
- 4 — Under the idler level assembly (Illustration 68, Fig. 14).
- 5 — On the worm shaft (Illustration 62, Fig. 11) where it contacts the gear of the rocker cam assembly. (Illustration 87, Fig. 11).
- 6 — On the outside edge of the cam (Illustration 87, Fig. 11).

- 7 — On the rubbing surfaces of the switch cam. (Illustration 100, Fig. 4).

USE LIGHT OIL AT THE FOLLOWING POINTS

- 1 — Idler (Illustration 60, Fig. 12) bearing on felt washer.
- 2 — On the self-aligning bearings of shafts (Illustrations 58 and 62, Fig. 33).
- 3 — Motor bearings.
- 4 — If new brake shoe assemblies (Illustrations 67 and 70, Fig. 12) are installed, apply one drop of light oil to each felt. Otherwise do not oil these felts.

Be very careful not to allow oil or grease to touch the rubber surfaces of the drive wheel (Illustration 60, Fig. 12). Any lubricant on these surfaces should be removed immediately with carbon tetrachloride. Excess lubricant on the brake felts will cause an oily surface on the supply of take-up drum. Such oil should be removed with carbon tetrachloride.

ELECTRICAL REPAIRS AND ADJUSTMENTS

The oscillator-amplifier circuit of the Model 80 wire recorder is simple and trouble proof. With the "Record-Listen" switch in the "Record" position the 6V6 acts as an oscillator, the 6SJ7 and 6J5 acting as amplifiers. In "Listen" position, the 6V6 acts in its usual capacity as an output amplifier tube.

CHANGES

Although minor changes and improvements have been made, four changes have been made in the amplifier circuit that will affect the service technician.



- 1—The neon volume level indicator circuit has been added to simplify maintaining a proper recording level without the use of an external meter.
- 2—The bias circuit of the 6SJ7 has been changed to the "contact potential" circuit for stability and simplified production.
- 3—The values of resistors No. R-3 and No. R-7 have been changed to the values indicated on the schematic to reduce sensi-

tivity and the probability of trouble with microphonic tubes.

- 4—Condenser C-12 has replaced the blue lead from terminal No. 3 of the 6V6 socket to the oscillator coil and the red lead from the center top of the oscillator primary has been removed from terminal No. 4 of the 6V6 socket and grounded. This removes DC from the oscillator coil and prevents speaker burn-out if the oscillator should ground.

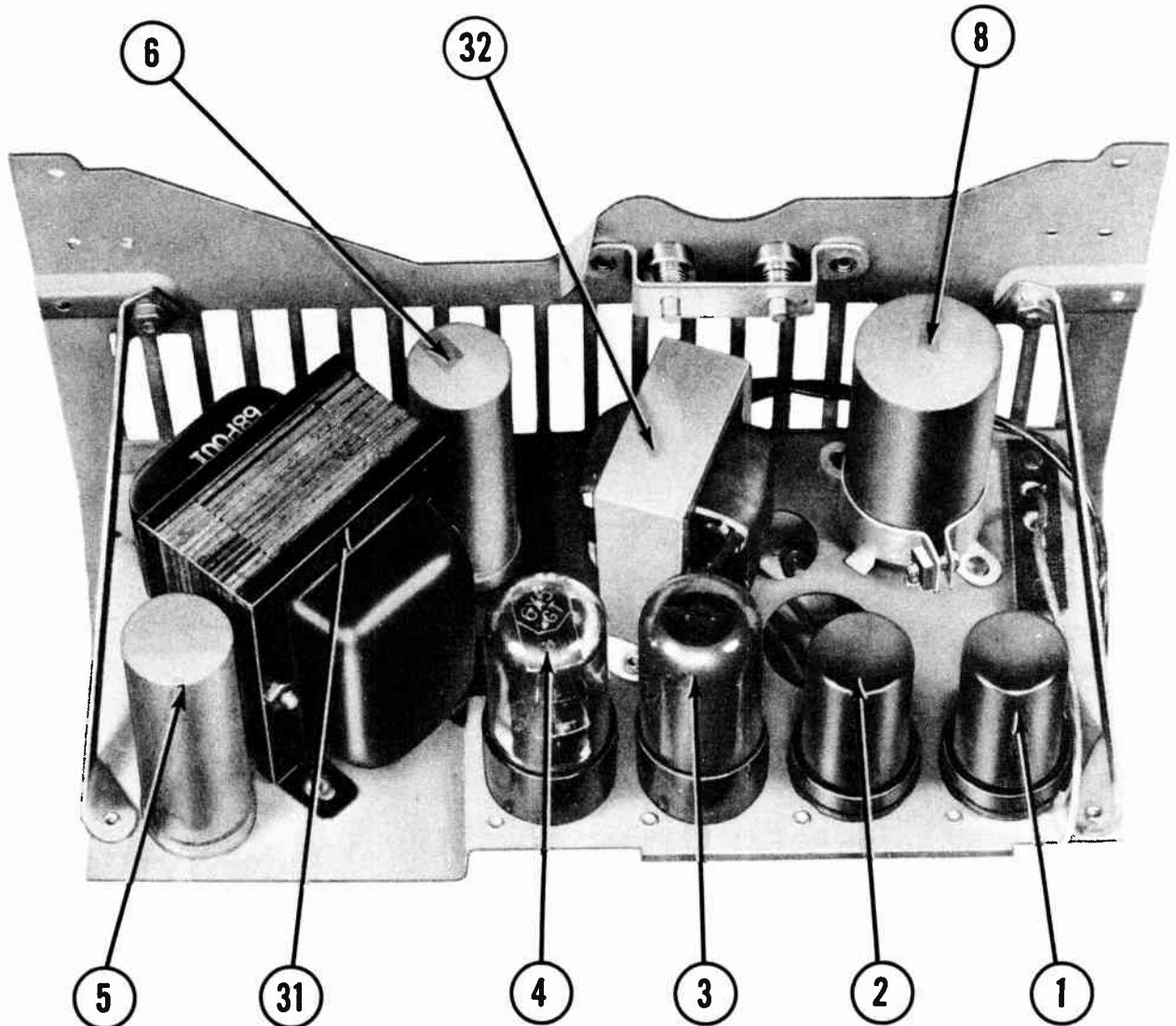

Fig. 26 — AMPLIFIER CHASSIS (TOP VIEW)

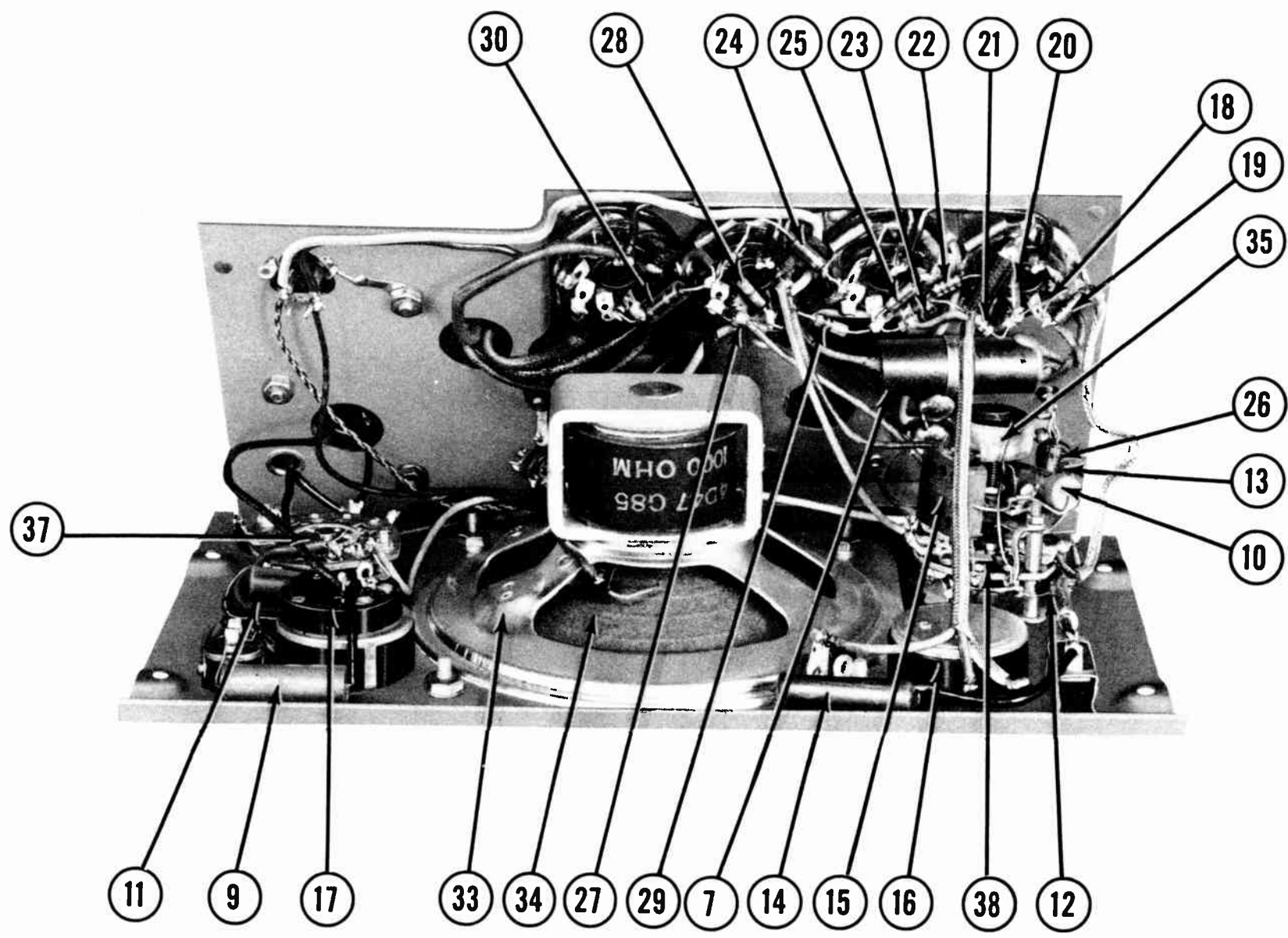

Fig. 27 — AMPLIFIER CHASSIS (BOTTOM VIEW)

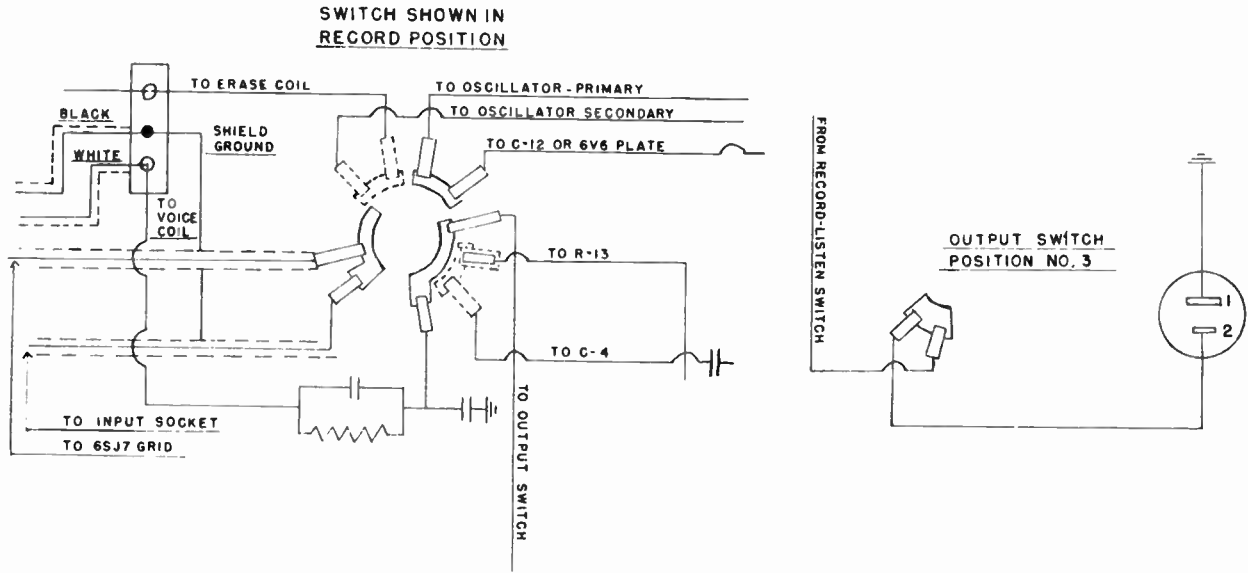

Fig. 29 — RECORD LISTEN SWITCH — RECORD POSITION; OUTPUT SWITCH POSITION No. 3

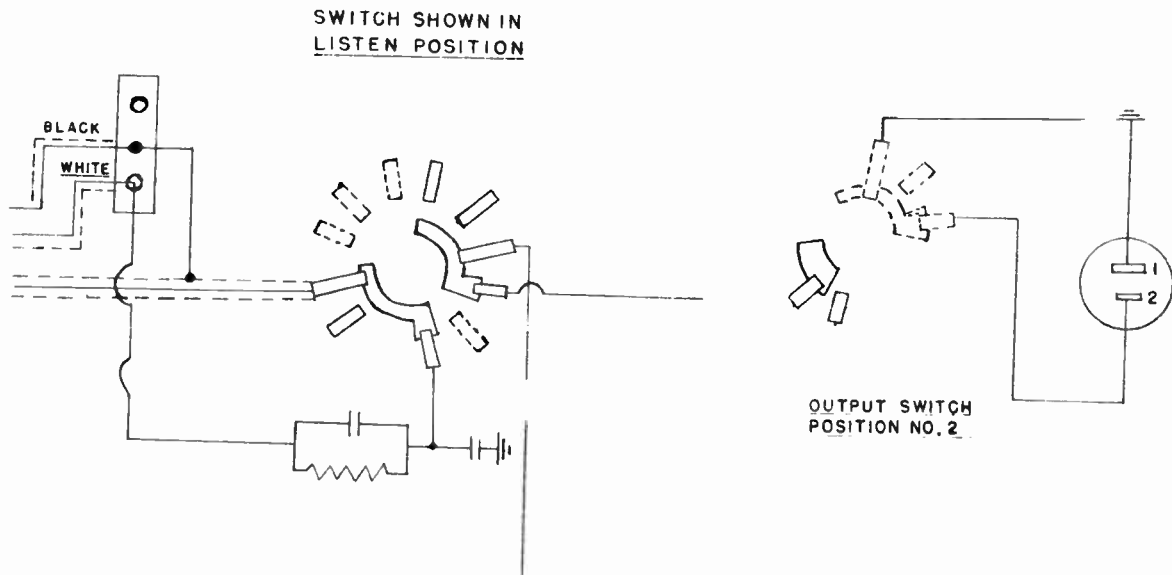

Fig. 30 — RECORD LISTEN SWITCH — LISTEN POSITION; OUTPUT SWITCH POSITION No. 2

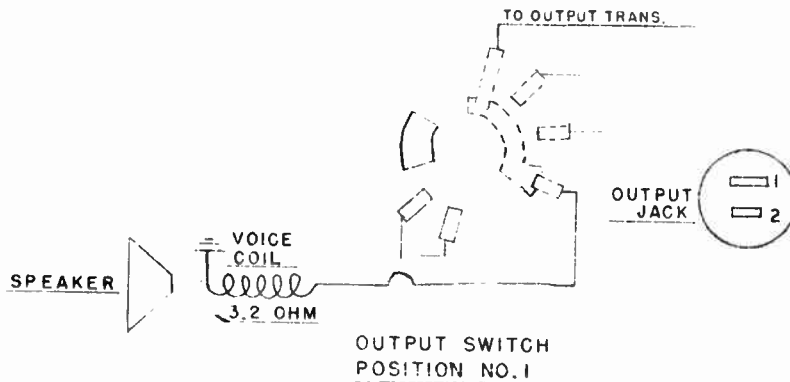

Fig. 31 — OUTPUT SWITCH — POSITION No. 1

**A—MACHINE WILL NOT RUN**

Check the fuse in the fuse holder (Illustration 64, Fig. 11). Replace with 1 amp. fuse if open but be certain that cause for open is removed.

B—SPEAKER FIELD BURNED OUT

Check oscillator coil (Illustration 35, Fig. 27) for grounded primary. If defective, replace coil assembly.

C—REPLACING THE OSCILLATOR COIL

While replacing a burned out oscillator coil, make the following circuit changes unless already made.

1—Unsolder the heavy blue lead from terminal No. 3 of the 6V6 socket. Solder one side of a .002 mfd. mica condenser to terminal No. 3 of the 6V6 and the blue lead to the other side.

2—Unsolder the heavy red lead from terminal No. 4 of the 6V6 socket, and solder it to the ground terminal on the coil assembly frame. This isolates the oscillator coil and prevents burn-out of the speaker field if the oscillator coil should burn out.

D—DOES NOT RECORD

Check the 6V6 tube. Check connections inside microphone plug for opens or grounds. Make certain that the lead to terminal No. 2

of the recording head is not grounded. Check the oscillator coil (35) (Fig. 27) for open connections. Check condensers C-4 and C-7 for opens or shorts.

A simple home made device will aid in testing the oscillator coil and output. Attach two leads to a 6.3 volt pilot light. Touch one lead to the red lead from terminal No. 3 of the recording head and ground the other lead. If the bulb burns brightly, the oscillator circuit is in good condition. The control lever must be in "Run" position.

E—DOES NOT ERASE

Switch contacts (Fig. 29) may not be making contact.

Condensers 4 and 7 (Fig. 28) may be open or shorted.

Defective 6V6 tube. Defective oscillator coil. See paragraph "C" for circuit changes. Defective recording head.

F—DOES NOT RECORD OR ERASE

First check oscillator and circuit as suggested previously. If recording head is suspected, substitute another head and check its operation. Do not attempt to repair a recording head but replace with a new one.

G—LOW RECORDING LEVEL

Check tubes, especially 6X5 and 6V6. May be caused by weak head, check by substitution.



VOLTAGE AND RESISTANCE MEASUREMENTS

All voltages measured with line voltage of 117 volts at 60 cycles with volume control in full counterclockwise and tone control in full clockwise positions.

All voltages shown are measured to ground (chassis).

A.C. voltages are measured with a rectifier type

instrument the sensitivity of which is at least 1000 ohms per volt.

D.C. voltages are measured with a D.C. type Vacuum Tube Voltmeter.

Voltages should be as shown plus or minus 10 percent.

READINGS TAKEN: RECORD-LISTEN SWITCH IN RECORD POSITION

OUTPUT SWITCH IN No. 1 POSITION RECORDER VOICE COIL CONNECTED

VOLTAGE

TUBE TYPE	PIN 1	PIN 2	PIN 3	PIN 4	PIN 5	PIN 6	PIN 7	PIN 8
(1) 6SJ7	0V.	3V. AC	0V. DC	-.1V. DC*	0V. DC	23.5V. DC	3V. AC	45V. DC
(2) 6J5	0V.	3V. AC	127V. DC	†	0V.	†	3V. AC	4.6V. DC
(3) 6V6GT	0V.	3V. AC	300V. DC	305V. DC	-45V. DC	†	3V. AC	9.5V. DC
(4) 6X5GT	0V.	3V. AC	350V. AC	0V.	350V. AC	0V.	3V. AC	350V. DC

*Cannot be measured with a 1000 ohm per volt meter.

†Not a tube element.

RESISTANCE

Measured to ground with a DC VTVM type ohm meter

TUBE TYPE	PIN 1	PIN 2	PIN 3	PIN 4	PIN 5	PIN 6	PIN 7	PIN 8
(1) 6SJ7	0 Ohms	.1 Ohms	0 Ohms	4.7 Meg.	0 Ohms	47K Ohms	.1 Ohm	487K Ohms
(2) 6J5	0 Ohms	.1 Ohms	288K Ohms	270K Ohms	1 Meg.	249K Ohms	.1 Ohm	1K Ohms
(3) 6V6GT	0 Ohms	.1 Ohms	225K Ohms	225K Ohms	35 K Ohms	35K Ohms	.1 Ohm	270 Ohms
(4) 6X5GT	0 Ohms	.1 Ohms	180 Ohms	INF	190 Ohms	INF	.1 Ohm	225K Ohms



MICROPHONES

The most common trouble with the crystal microphone is caused by letting the microphone get too warm. Temperatures over 130 degrees F. cause the crystal elements to soften and the microphone is rendered inoperative.

The Webster-Chicago Wire Recorder is supplied with a high impedance type microphone. Low impedance microphones (35-50 ohm and 200-250 ohm, etc.) may be substituted by using a match-

ing transformer between the microphone and the input socket.

Before returning any microphones to the factory for replacement, check the connections inside the plug to make sure that they are not shorted or broken and that the lead to terminal No. 2 is not grounded. If terminal No. 3 is grounded, the wire recorder will not operate in playback even though a previously recorded spool of wire is on the machine.

WRAP THIS CONNECTION WITH CELLULOSE TAPE TO INSULATE FROM GROUND AND OTHER TERMINALS

PIGTAIL FROM SHIELD MUST BE GROUNDED TO CORD CLAMP

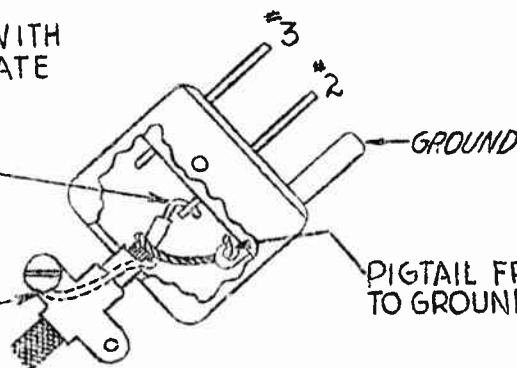

PIGTAIL FROM SHIELD SOLDERED TO GROUND LUG - NO FRAYED ENDS

Fig. 32 — MICROPHONE PLUG CONNECTIONS

Do not remove the back cover from the microphone under any circumstances. This will void the guarantee and Webster-Chicago will not credit microphones which have been opened for any

reason. If the microphone proves to be defective after the plug connections have been checked and found to be correct, return the microphone to Webster-Chicago for immediate replacement.

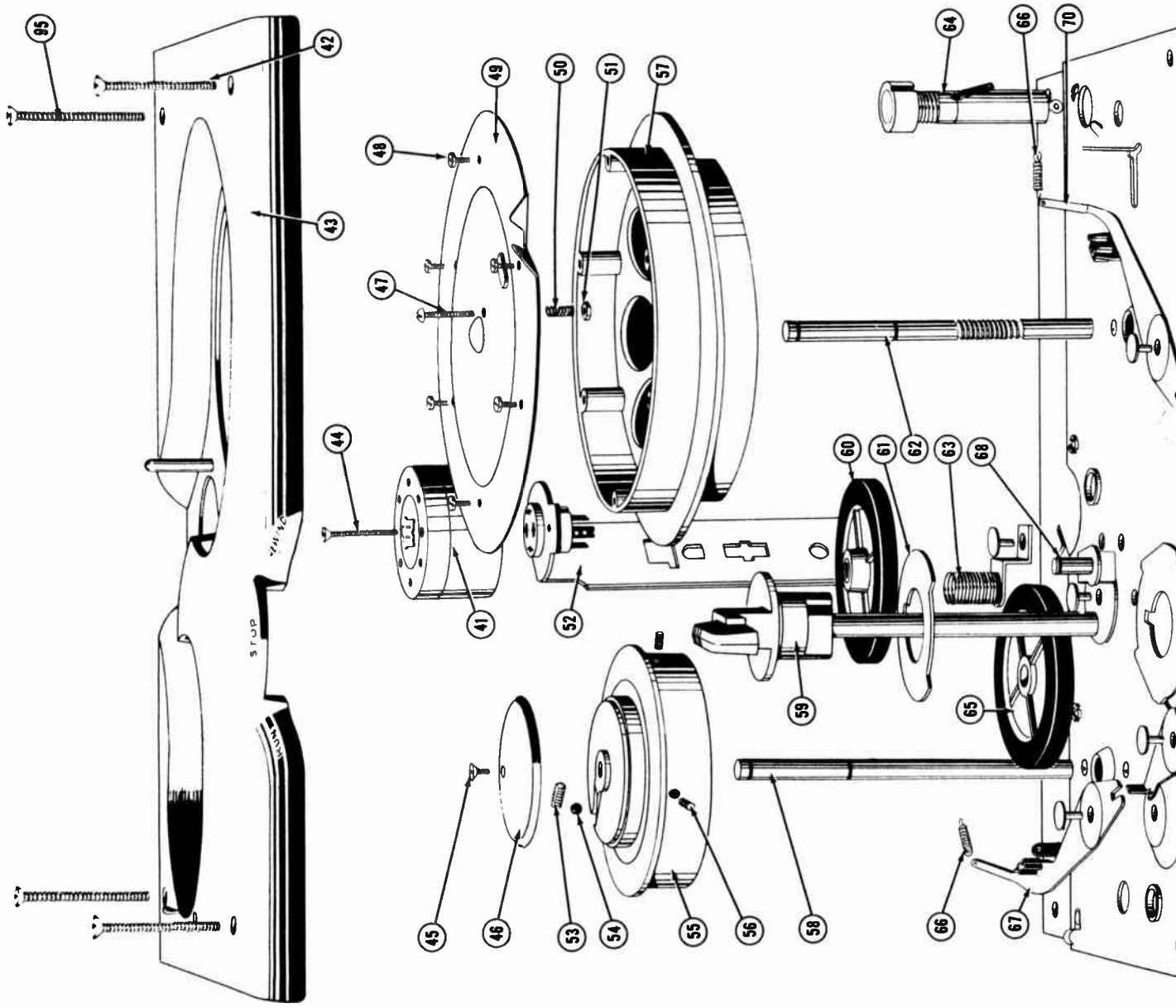

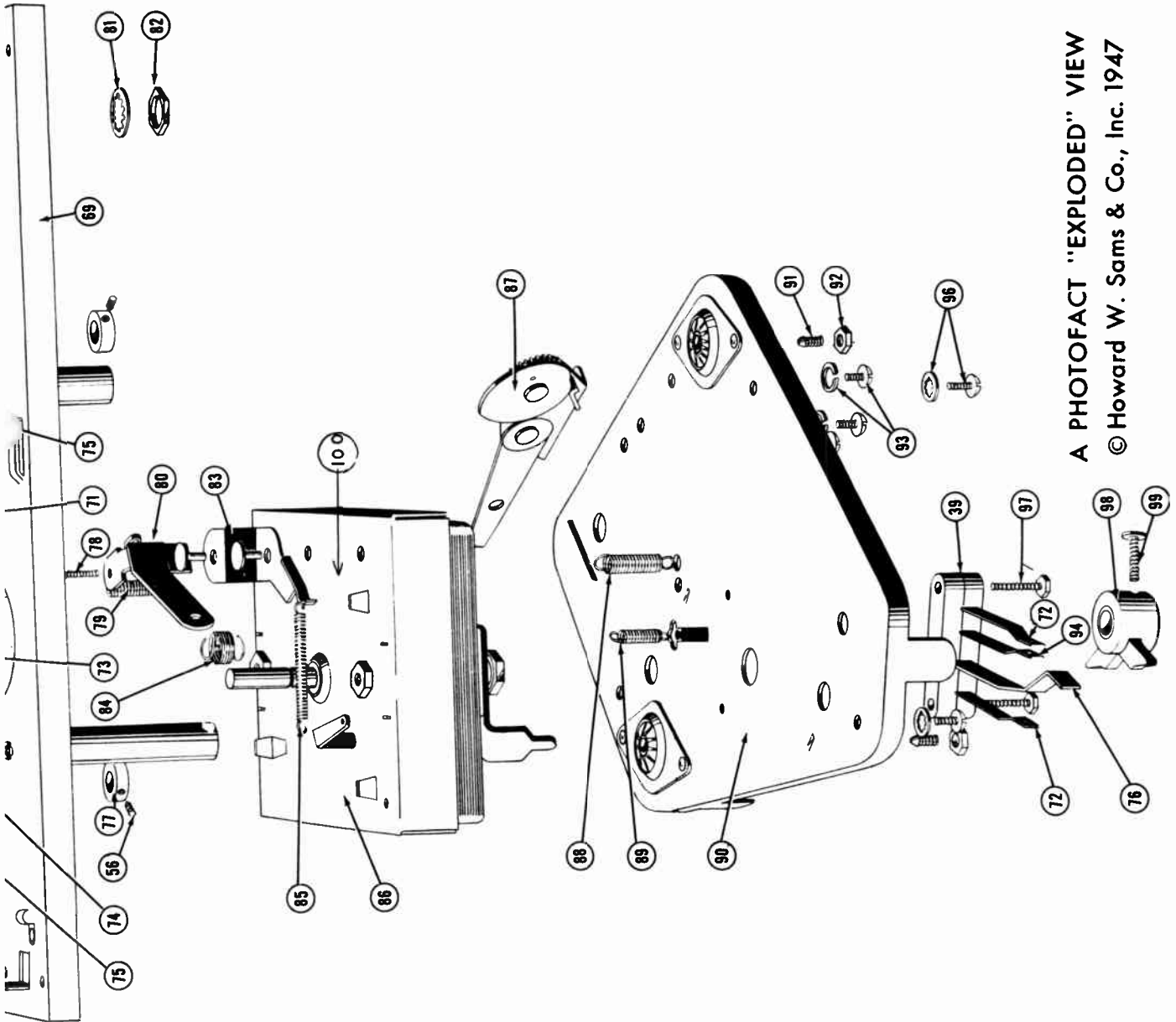

A PHOTOFACT "EXPLODED" VIEW
© Howard W. Sams & Co., Inc. 1947

Fig. 33 — PARTS LAYOUT



REPLACEMENT PARTS LIST

WEBSTER-CHICAGO MODEL 80 WIRE RECORDER

Illustration No.	Replacement Part Number	Location, Purpose or Description
24	R-1	1,000 Ohm 1/2 Watt
23	R-2	100,000 Ohm 1/2 Watt
20	R-3	47,000 Ohm 1/2 Watt
19	R-4	Not Used Currently
21	R-5	220,000 Ohm 1/2 Watt
	R-6	39,000 Ohm 1/2 Watt
22	R-7	220,000 Ohm 1/2 Watt
18	R-8	4.7 Megohm 1/2 Watt
26	R-9	68,000 Ohm 1/2 Watt
29	R-10	820 Ohm 1/2 Watt
30	R-11	270 Ohm 1 Watt
28	R-12	68,000 Ohm 1/2 Watt
27	R-13	820 Ohm 1/2 Watt
16	R-14	31P035 1 Megohm Vol. Control
17	R-15	31P036 50,000 Ohm Tone Control
	R-16	1 Megohm 1/2 Watt 5%
	R-17	270,000 Ohm 1/2 Watt
	R-18	220,000 Ohm 1/2 Watt 5%
13	C-1	.001 Mfd. 600 Volt Paper
14	C-2	.02 Mfd. 400 Volt Paper
8	C-3	30P057 1.0 Mfd. 200 Volt Paper
10	C-4	.002 Mfd. 600 Volt Paper
9	C-5	.05 Mfd. 400 Volt Paper
12	C-6	.0001 Mfd. 600 Volt Paper
15	C-7	.01 Mfd. 400 Volt Mica
11	C-8	.05 Mfd. 400 Volt Paper
	C-9	.01 Mfd. 400 Volt Paper
	C-10	.01 Mfd. 100 Volt Shielded
5	EC-1	30P049 25-15 Mfd. 450-350 Volt Electrolytic
24	EC-2	30P056 10 Mfd. 25 Volt Electrolytic
6	EC-3	30P050 15-15-40 Mfd. 250-350-25 Volt Electrolytic
31		68P001 Power Transformer
32		67P003 Output Transformer to Match 3.2 Ohm Speaker
33		76P018 Speaker
35		65P015 Oscillator Coil
36		Pilot Light — Type 50 G E
37		32P041 Output Channel Selector Switch
38		32P040 "Record-Listen" Switch
39		49P060 Contact Switch Assembly
40		Fuse 1 Ampere



Illustration No.	Replacement Part Number	Location, Purpose or Description
41	11X180	Recording Head Assembly
42	26P281	No. 8-32 x 1 $\frac{7}{8}$ Phillips Rec. O.H.M.S.
43	11X213	Top Cover
44	26P309	No. 3-48 x $\frac{7}{8}$ " O.H.M.S.
45	26P279	No. 5-40 x $\frac{3}{16}$ " O.H.M.S.
46	45P279	Chuck Cap
47		No. 3-48 R.H.M.S.
48	26P278	No. 6-32 x $\frac{1}{4}$ " B.H.S.T. Screw
49	11X181	Take-up Drum Cover Assembly
50	46P137	Compression Spring
51		No. 3-48 x $\frac{3}{16}$ x $\frac{1}{16}$ " Hex Nut
52	11X208	Slide and Socket Assembly
53	46P143	Compression Spring
54	48P014	Steel Ball $\frac{3}{16}$ " Diameter
55	42P090	Chuck — Wire Supply Spool
56	26P633	No. 8-32 x $\frac{3}{16}$ " Bristol Socket Set Screw Conepoint
57	42P091	Take-up Drum
58	41P558	Shaft — Wire Supply Spool
59	42X092	Control Lever
60	11X003	Idler Wheel Assembly
61	45P495	Top Brake Cam
62	47P029	Take-up Drum Shaft
63	38P024	Pilot Light Receptacle
64	38P026	Fuse and Extractor Post
65	11X195	Drive Wheel and Tire Assembly
66	46P130	Tension Spring
67	11X183	Left Brake Shoe Assembly
68	11X179	Idler Lever Assembly
69	11X186	Base Plate Assembly
70	11X184	Right Brake Shoe Assembly (Serial 5000-17000)
71	45P521	Brake Lever -- Right
72	11X176	M & O Spring and Crowned Contact Assembly
73	45P494	Bottom Brake Cam
74	45P522	Brake Lever — Left
75	46P131	Tension Spring
76	11X177	Detent Spring and Contact Assembly
77	41P557	Thrust Collar
78		No. 6-32 x $\frac{7}{8}$ " Fil. H.M.S.
79	46P135	Compression Spring
80	45P544	Head Adjustment Bracket



<i>Illustration No.</i>	<i>Replacement Part Number</i>	<i>Location, Purpose or Description</i>
81		Lockwasher
82		Lock Nut
83	46P145	Tension Spring (Serial 17000 — Up)
84	46P132	Tension Spring
85	46P133	Tension Spring
86	15X0881	Motor Assembly
87	11X172	Cam and Rocker Assembly
88	46P144	Tension Spring
89	46P134	Tension Spring
90	11X185	Bottom Plate Assembly
91	41X591	Adj. Screw and Insert Assembly
92	26P077	No. 10-32 x $\frac{3}{8}$ x $\frac{1}{8}$ " Hex Nut
93		No. 8-32 x $\frac{1}{4}$ " Sems H.H. Slot I.T.
94	11X178	M & O Spring and Flat Contact Assembly
95	26P282	No. 8-32 x $2\frac{1}{8}$ " Phillips Rec. O.H.M.S.
96		No. 8-32 x $\frac{3}{8}$ " Sems H.H. Slot I.T.
97		No. 8-32 x $\frac{7}{8}$ " Hex. Head S.T. Screw
98	49P059	Switch Cam
99		No. 6-32 x $\frac{1}{2}$ " R.H.M.S.
100	17X420	Motor Cover Assembly and Cam Follower
101	11X247	Right Brake Shoe Assembly (Serial 17000 — Up)



CONDENSED FACTORY TEST SPECIFICATIONS

Follow this simple routine and be certain that the entire wire recorder is completely tested and adjusted.

MECHANICAL

Motor — Shaded pole induction type. 18 watts at 120 volts, 60 cycles Alternating Current (no load). Starting torque 1.7 inch ounces on 120 volts, 60 cycles A.C. at room temperature. Rotor speed 1720 to 1740 RPM (no load). All motor leads No. 20 stranded, tinned copper wire with Underwriters approved insulation.

Motor Tension — Tension on motor tension cam follower (Located on top surface of Motor Cover) is by tension spring, tension is 20 oz. plus and minus 1 oz. Adjustment is made by bending shear form lug. At 18 oz. spring shall retract cam lever.

Shafts — Chuck (supply spool) shaft and Drum (take-up drum) shaft must be free running with no brake pressure. Adjustments by nut under bottom plate.

Speed — Speed of Take-up Drum when recording or transcribing shall be 109 to 115 RPM.

Brakes — See sketch in this manual for care and adjustments.

Slide — Be sure slide has a free up and down motion without binding or lateral play. Make certain all leads allow slide to work free.

Recording Head — No lateral play. Should feed wire to either drum or supply spool equidistant between flanges.

Drive Wheel Pressure — Pressure of the drive wheel tire in the "Run" position, on the Take-up Drum should be from 7 to 9 oz.

Motor Shaft Pressure — Pressure on the idler wheel in the "Rewind" position of the Motor Shaft should be from 2 to 3 oz.

"Wow" — When recording or transcribing should not be more than 1/2 of 1%.

AMPLIFIER AND PANEL

Limits — All limits are based on an Input Voltage of 117.0.

Voltages — Record Listen Switch in Record position, Voltages should be as indicated on Voltage chart.

Power Consumption — Amplifier 46 Watts. Motor 18 Watts — Total 64 Watts.

"RECORD-LISTEN" SWITCH IN "LISTEN" POSITION

Amplifier Check No. 1 — With output switch in No. 1 position and volume and tone control fully advanced, .005 Volts at 1000 cycles is fed to grid side of 68,000 Ohm — .001 MFD equalizing network. Check speaker for audible distortion and rattle. Tap tubes for microphonic and possible failure.

Amplifier Check No. 2 — With output switch in No. 2 position, volume and tone controls fully advanced, and signal applied as in above, output voltage across an external 3.2 Ohm load should be 2.2 Volt minimum, undistorted. If output voltage is greater than 2.2 Volts but distorted, the volume control setting may be retarded until the output wave shape is undistorted. This setting is alright if the output voltage across the 3.2 Ohm load is at least 2.2 Volts.



Amplifier Check No. 3 — With output switch in No. 3 position, volume and tone controls fully advanced, and signal applied as in above, the output voltage shall be 6 Volts minimum, undistorted. If greater than 6 Volts, but distorted, the volume control may be retarded until the output wave is undistorted, at this new setting the output voltage should be at least 6 Volts.

Controls — Check all controls for correct operation and noise.

Hum and Noise Voltage — With the grid of the 6SJ7 tube grounded, the tone and volume controls fully advanced, the output switch in position No. 2, the hum and noise voltage shall be .010 Volts maximum measured at the output jack. With the output switch in position No. 3, the hum and noise voltage should be .060 Volts maximum.

RECORD-LISTEN SWITCH IN RECORD POSITION

Output switch in No. 3 position, tone and volume controls fully advanced, .01 volts at 1000 cycles is fed into the first amplifier stage thru the input receptacle. The output voltage at the output jack should be 7.0 volts minimum, undistorted. If the output voltage is greater than 6.0 volts, but distorted, the volume control setting may be retarded until the output wave shape is undistorted. The amplifier will be considered to be alright if, at this new setting, the output voltage is at least 6.0 volts.

The erase frequency should be 35 to 45 kilocycles. The erase voltage should be 4.8 to 5.2 volts. The erase current should be .9 to 1.0 amperes. R.F. (Be sure to use an R.F. Ammeter).

Volume control setting is retarded to a position such that exactly seven volts are measured with all other conditions identical to those of test above and a 1000 cycle note recorded on wire.

RECORD-LISTEN SWITCH IN LISTEN POSITION

The wire is rewound and the recording made above is played back and checked according to the following:

With output switch in position 1, the 1000 cycle note is listened to for excessive "Wow".

With output switch in position 2, volume and tone controls fully advanced, the 1000 cycle voltage across an external 3.2 Ohm load shall be 1.2 volts minimum, undistorted. If the output voltage is greater than 1.2 volts, but distorted, the volume control setting may be retarded until the output wave shape is undistorted. At this new setting of the volume control the output voltage should be at least 1.2 volts.

With output switch in position 1, recorded speech and music is listened to for audible distortion, speaker rattle, microphonic tubes, excessive noise and hum.

ABILITY TO ERASE

With the record-listen switch in the record position, a portion of the recorded wire is run thru in the forward direction with the volume control in the extreme counterclockwise position. This portion is then rewound and played back for check of adequate erasing.



THEORY OF MAGNETIC RECORDING

BIBLIOGRAPHY

1. Long, T. H., "New Wire Recorder Head Design". *Electrical Engineering*, April 1946, page 216.
2. Wooldrige, D. E., "Signal and Noise Levels in Magnetic Tape Recording". *Electrical Engineering*, June 1945, page 343.
3. *Science News Letter*, D. 22, 45; 48:399.
4. Pugsley, D. W., "Wire Recording". *Electrical Engineering*, July 1946, page 316.
5. Holmes, L. C., and Clark, D. L., "Supersonic Bias for Magnetic Recording". *Electronics*, July 1945, page 126.
6. Camras, Marvin, "A New Magnetic Wire Recorder". *Radio News*, Radi-
onics Edition, November 1943.
7. Javitz, Alex E., "An Appraisal of Design Trends in Magnetic Sound Record
ers". *Electrical Manufacturing*, June 1946.
8. Yoder, Robert M., "Young Man With a Wire". *The Rotarian*, February 1944.
9. *Tele-Tech*, January 1947. "Paper Tape Magnetic Recorder".
10. Rosenstein, Allen B., "Principles and Methods of Magnetic Recording".
Radio News, December 1946.
11. Pugsley, D. W., "Engineering Details of Magnetic Wire Recorder". *Elec-
tronics Industries*, January 1944.



The Choice of Music Lovers.