

ICD 08559

JULY 1989 \$2.50

CANADA \$3.50

# MODERN ELECTRONICS™

THE MAGAZINE FOR ELECTRONICS & COMPUTER ENTHUSIASTS

- **Real-Time Computer Control and Measurement**
- **Piezoelectric Experiments**

*Also:*

- **How To Use DC Voltmeters**
- **Generating Pulses & Waveforms**
- **Automatic Car Headlights Controller**
- **How To Use DC Voltmeters**

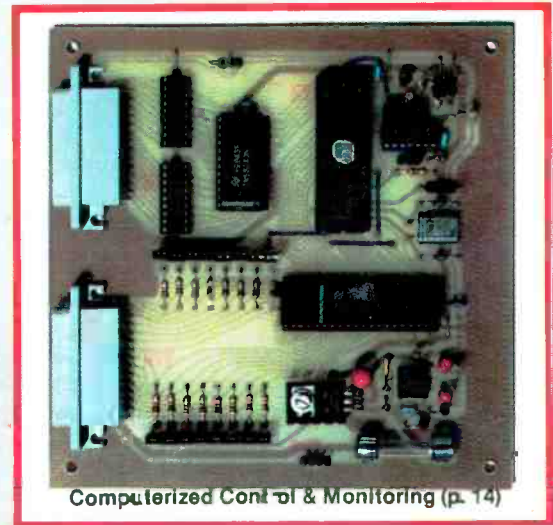

Computerized Control & Monitoring (p. 14)

- **Slave Modules For IR Remote-Control System**



Hewlett-Packard Low-Cost Hand-Held DMMs (p. 10)

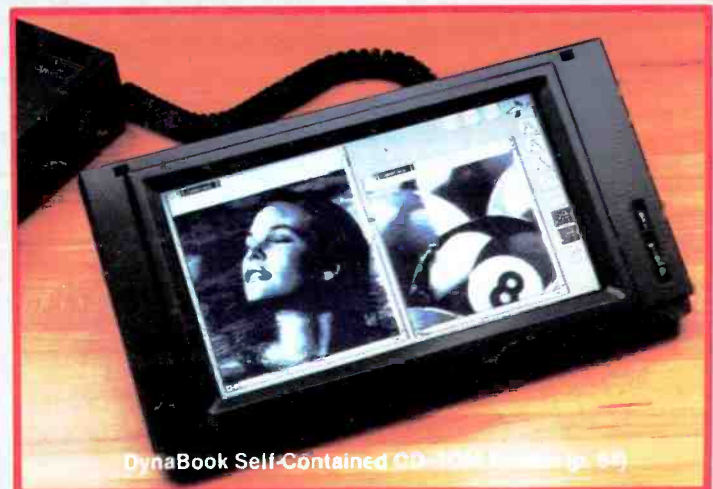

DynaBook Self-Contained CD-ROM Reader (p. 54)



**Plus: Evaluating the "DynaBook" Portable CD-ROM Reader, Software Toolworks' "Twist & Shout" Software, Astral Development's "Picture Publisher," Silicon Beach Software's "Digital Darkroom" and Inset Systems' "Hijaak" • Smart Weather Monitor Construction Details • Electronics & Computer News ... more.**

# OPTOELECTRONICS



## COUNTERING THE RF THREAT COUNTER/COUNTER SERIES FREQUENCY COUNTERS AND RF DETECTORS

Affordable, compact, and ultra-sensitive. More and more people are using CC Series Instruments than ever before for RF detection. Now widely used for personal security, safety and peace of mind, these instruments can locate, identify, isolate, and counter low power radio frequency transmitters that may be concealed in offices, automobiles, conference rooms or are being carried inside clothing, pocket books, etc.

	Range From:	To:	Price:	Sensitivity @ 150 MHz
CCA	10 MHz	550 MHz	\$299	0.1 mV
CCB	10 MHz	2.5 GHz	\$99	1 mV

**Model CCA Frequency Counter/RF Detector**—Ultra sensitive frequency counter optimized for picking up low power RF transmitters. Features include an RF Indicator LED to confirm presence of RF source nearby. RF Indicator has variable threshold sensitivity control that is adjustable from top of instrument. CCA has 8 digit red .28" LED displays. Internal Ni-Cad batteries provide 2-5 hour portable operation with continuous operation from AC line charger/power supply supplied.

**Model CCB RF Detector**—Useful for locating exact position of RF source. Will indicate presence of a 1 milli watt transmitter within a twenty foot distance. Ten segment LED display will successively illuminate segments as the distance to transmitter decreases. Powered by 9v alkaline battery for up to 4 hours continuous operation. Front panel switch selects between bar graph and power saving moving spot display. Front panel zero and full scale adjustment pots are provided.

Both instruments require an antenna. Order the model TA-100S Telescoping RF pick up antenna, \$12, for maximum sensitivity. The flexible model RD-100 Rubber Duck is \$20.

Model CC12 vinyl zipper carrying case is \$10. Aluminum cabinet is 3.9" H x 3.5" W x 1.1" D. One year parts and labor guarantee. Add 5% shipping (minimum \$2) all orders.

ORDER FACTORY DIRECT  
1-800-327-5912

**OPTOELECTRONICS INC.**

5821 N.E. 14th Avenue  
Fort Lauderdale, Florida 33334

FLA (305) 771-2050  
FAX (305) 771-2052



Orders to U.S. and Canada add 5% to total (\$2 min, \$10 max)  
Florida residents add 6% sales tax. COD fee \$3.  
Foreign orders add 15%

CIRCLE 42 ON FREE INFORMATION CARD



# SELECT 5 BOOKS for only \$4.95

(values to \$117.70)  
and get a **FREE Gift!**

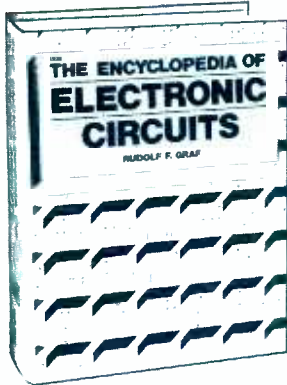
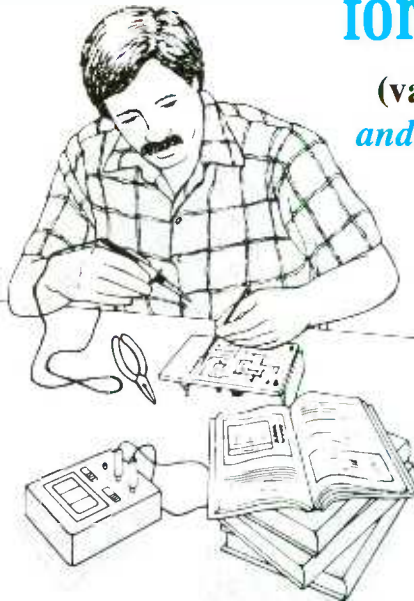

1938 \$60.00  
Counts as 3

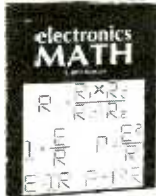

1962 \$22.95



3195 \$28.95  
Counts as 2



2831P \$14.95

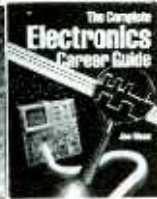

3110 \$19.95

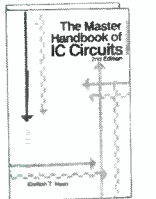

3185 \$34.95  
Counts as 2

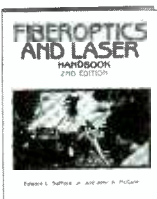

2981P \$16.95



3054 \$19.95



2613 \$24.95



3133 \$15.95



1367P \$18.95

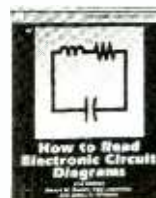

2880 \$20.95



3234 \$24.95



1897P \$14.95



2809 \$27.95  
Counts as 2



1594P \$17.95



3212 \$34.95  
Counts as 2

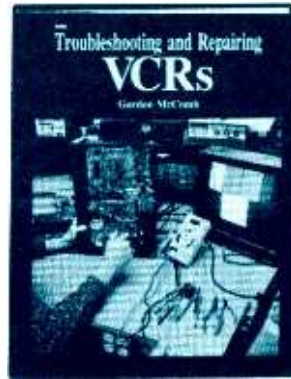

2960 \$26.95  
Counts as 2



3034 \$19.95



2987P \$16.95

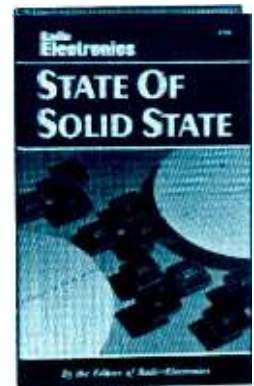

2733 \$14.95

Electronics projects . . . ideas . . . the latest technology  
all at up to 50% off publishers' prices!

**Membership Benefits • Big Savings.** In addition to this introductory offer, you keep saving substantially with members' prices of up to 50% off the publishers' prices. • **Bonus Books.** Starting immediately, you will be eligible for our Bonus Book Plan, with savings of up to 80% off publishers' prices. • **Club News Bulletins.** 14 times per year you will receive the Book Club News, describing all the current selections—mains, alternates, extras—plus bonus offers and special sales, with scores of titles to choose from. • **Automatic Order.** If you want the Main Selection, do nothing and it will be sent to you automatically. If you prefer another selection, or no book at all, simply indicate your choice on the reply form provided. As a member, you agree to purchase at least 3 books within the next 12 months and may resign at any time thereafter. • **Ironclad No-Risk Guarantee.** If not satisfied with your books, return them within 10 days without obligation! • **Exceptional Quality.** All books are quality publishers' editions especially selected by our Editorial Board.

©1989 ELECTRONICS BOOK CLUB®, Blue Ridge Summit, PA 17294-0810  
All books are hardcover unless number is followed by a "P" for paperback (Publisher's Prices shown).

**FREE when you join!**

**15 Easy Electronic Projects From Delton T. Horn**  
Projects you can build—some unique, some old favorites—from the author's vast treasury of electronics know-how.

a  
**\$7.95**  
value!



**ELECTRONICS BOOK CLUB®**  
Blue Ridge Summit, PA 17294-0810

Please accept my membership in the Electronics Book Club® and send the 5 volumes listed below, plus my FREE copy of *Delton T. Horn's All-Time Favorite Electronic Projects* (3105P), billing me \$4.95 plus shipping and handling charges. If not satisfied, I may return the books within ten days without obligation and have my membership cancelled. I agree to purchase at least 3 books at regular Club prices (plus shipping and handling) during the next 12 months and may resign any time thereafter.

Name \_\_\_\_\_  
Address \_\_\_\_\_  
City \_\_\_\_\_  
State \_\_\_\_\_ Zip \_\_\_\_\_ Phone \_\_\_\_\_  
Signature \_\_\_\_\_

Valid for new members only. Foreign applicants will receive special ordering instructions. Canada must remit in U.S. currency. This order subject to acceptance by the Electronics Book Club®. MDNE789



1625P \$18.95



2790 \$19.95



2843P \$16.95

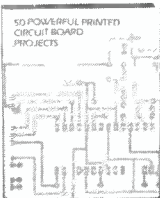

2972 \$23.95



1532P \$14.95

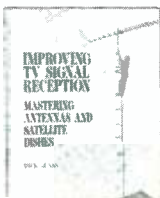

2970P \$15.95



# NEW SUPER LONG PLAY TAPE RECORDERS

12 Hour Model — \$119.00\*  
USES D-120 TAPE

Modified Panasonic Slimline, high quality AC-DC Recorders provide 6 continuous hours of quality recording & playback on each side of cassette for a total of 12 hours. Built-in features include: • Voice level control • Digital counter, etc. TDK DC 120 Cassette Furnished.



## PHONE RECORDING ADAPTER

Records calls automatically. All Solid state connects to your telephone jack and tape recorder. Starts recording when phone is lifted. Stops when you hang up. **\$24.95\*** FCC APPROVED



## VOX VOICE ACTIVATED CONTROL SWITCH

Solid state Self contained. Adjustable sensitivity. Voices or other sounds automatically activate and control recorder. Uses either recorder or remote mike. **\$28.50\***

\*Add for ship & hdg. Phone Adapter & Vox \$1.50 ea. Recorders \$4.00 ea. Cal. Res. add tax. Mail order, VISA, M/C, COD's OK. Money Back Guarantee. Qty. disc avail. Dealer Inquiries invited. Free data.

**AMC SALES INC.** Dept. M6335 Lubec St., Box 928 Downey CA 90241 Phone (213) 869-8519

CIRCLE 53 ON FREE INFORMATION CARD

# ATTENTION! ELECTRONICS TECHNICIANS

EARN YOUR **B.S.E.E. DEGREE**

## THROUGH HOME STUDY

Our New and Highly Effective Advanced-Placement Program for experienced Electronic Technicians grants credit for previous Schooling and Professional Experience, and can greatly reduce the time required to complete Program and reach graduation. No residence schooling required for qualified Electronic Technicians. Through this Special Program you can pull all of the loose ends of your electronics background together and earn your B.S.E.E. Degree. Upgrade your status and pay to the Engineering Level. Advance Rapidly! Many finish in 12 months or less. Students and graduates in all 50 States and throughout the World. Established Over 40 Years! Write for free Descriptive Literature

## COOK'S INSTITUTE OF ELECTRONICS ENGINEERING

**CIE** 4251 CYPRESS DRIVE JACKSON, MISSISSIPPI 39212

CIRCLE NO. 148 ON FREE INFORMATION CARD

# MODERN ELECTRONICS

THE MAGAZINE FOR ELECTRONICS & COMPUTER ENTHUSIASTS

JULY 1989

VOLUME 6, NUMBER 7

## FEATURES

- 14 Easy Computerized Control and Monitoring**  
Economical way to monitor sensors and actuate devices using a computer, external controller and BASIC. *By Daniel N. Eggert*
- 32 Pulse Circuits Revisited**  
Generating pulses and waveforms from experimental circuits. *By Joseph J. Carr*
- 36 How To Use DC Voltmeters**  
Some useful tricks of the trade for getting the most out of your dc voltmeter. *By Robert G. Middleton*
- 41 A 6-Channel IR Remote-Control System (Part II, Conclusion)**  
How to build slave control modules. *By Anthony J. Caristi*
- 48 A Smart Weather Monitor (Part II)**  
Construction details for the CPU and display modules. *By Thomas R. Fox*
- 54 Automatic Headlamps Circuit**  
Automatically turns on car headlights when ignition is on and disables them when ignition is off. *By Kenneth R. Cooper*

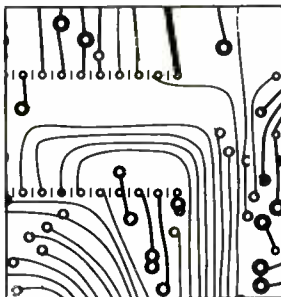

48

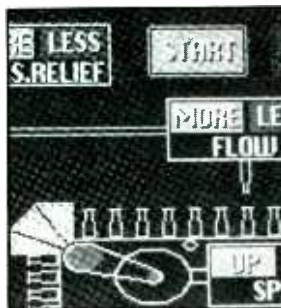

64



72

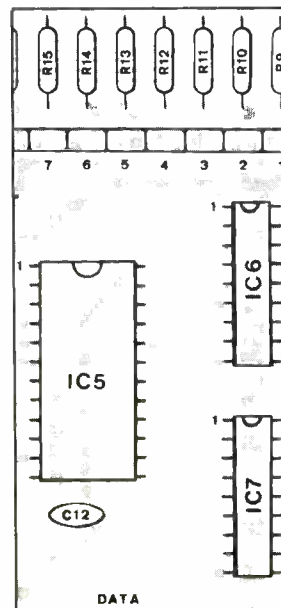

14

## PRODUCT EVALUATIONS

- 64 DynaBook—A Self-Contained, Portable CD-ROM Reader**  
*By John McCormick*

## COLUMNS

- 67 Electronics Notebook**  
Experimenting With the Piezoelectric Effect. *By Forrest M. Mims III*
- 72 PC Capers**  
Evaluating Astral Development's "Picture Publisher," Silicon Beach Software's "Digital Darkroom" & Inset Systems' "Hijaak V. 1.1B." *By Ted Needleman*
- 76 Software Focus**  
Software Toolworks "Twist & Shout." *By Joseph Desposito*

## DEPARTMENTS

- 6 Editorial**  
The Short Stick. *By Art Salsberg*
- 7 Letters**
- 8 Modern Electronics News**
- 10 New Products**
- 81 Advertisers Index**





## Tools Of The Trade



### Brought To You By MCM Electronics

As an experienced service technician, you too must rely on the tools of your trade to achieve the kinds of professional results your customers have every right to expect.

To get the "tools" you need... when you need them, look no further than the MCM Electronics Catalog. Our huge inventory of more than 11,000 in-stock items, competitive prices, convenient TOLL-FREE phone lines, super-fast order processing and flexible payment terms make MCM your best choice for all your parts and components needs.

Get your hands on an MCM Catalog today and find out why thousands of satisfied MCM customers come to us for the "tools" that keep them at the top of their trade!

**For Your FREE ONE-YEAR SUBSCRIPTION to the MCM Electronics Catalog... CALL TOLL-FREE 1-800-543-4330**

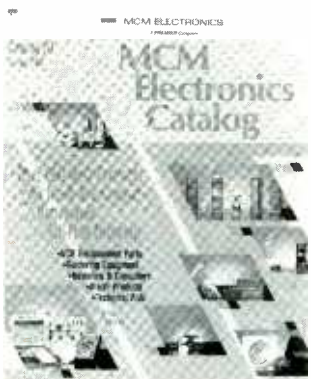

Source No. ME-48



**MCM ELECTRONICS**  
650 CONGRESS PARK DR.  
CENTERVILLE, OH 45459-4072  
A PREMIER Company

CIRCLE 73 ON FREE INFORMATION CARD

### One More Turn

• In Fig. 1 of my "The MIDI Music Revolution" (April 1989), it appears that a turn of the twisted-pair wire lines was omitted, causing pin 4 of the OUT port to connect to pin 5 of the IN port, and vice-versa. According to the official specification, pin 4 always connects to pin 4 and pin 5 always connects to pin 5. Also, the positions of D2 and the LED in Sharp PC-900 optical isolator IC2 must be reversed for the circuit to operate. Finally, the MIDI "through" port is almost universally referred to as a "THRU" port in books and magazines. While the "through" spelling is correct, it's a lot easier to read the simpler spelling when one is leaning over several pieces of gear and is trying to figure out why his setup isn't working as it should.

Charles R. Fischer

### A BASIC Complaint

• The two-part project article "Microprocessor Control With BASIC" by Jan Axelson and Jim Hughes that appeared in the April and May 1989 issues is one of the most interesting projects I have read in recent years for using a microprocessor. The possibilities with this project and its potential usage are almost endless. This brings up my BASIC complaint: I feel that the reader was left a little short with regard to explanation of how various input and output devices could have been connected to the circuit. The authors stated at the end of Part I that they would show how to add such "real-world" inputs and outputs as sensors and displays to transform the Microsys into the Tempwatch Smart Thermometer. Fine, but it would be nice if we could have a Part III that expands upon the possibilities of this project.

William D. Lewis  
San Jose, CA

### Forrest Mims Fan

• I have been an avid reader of the books and articles written by Forrest Mims for years. His interesting and well-written articles have given me many ideas for building interesting circuits. Besides the enjoyment I get out of what he has written, I feel they are a good way to get young people interested in pursuing careers in electronics.

Tom Wheless  
Eagle, ID

### Negative-Logic Booster

• "Understanding Negative Logic" in the October 1988 issue of *Modern Electronics* was interesting in general, but Mr. Horn's closing statement was most astute. It is *very easy* to confuse positive and negative logic. As a digital circuit designer, I find it better to stick with one approach and then solve the logic problem with Boolean algebra. For example, in the article's first truth table, eight combinations of A,B,C,D yield an output of "1." Using the simple rules of Boolean algebra, these terms are combined or reduced to the expression  $AD + BC + BD$ , which is read "A and D or B and C or B and D." This expression can be further factored to  $BC + D(A + B)$ , arriving at the logic circuit shown in Fig. 2(B)—which, by the way, is the positive-logic diagram. Boolean algebra is fun and easy to work with.

Bill Holsinger  
National Institutes of Health  
Bethesda, MD

## The Short Stick

Listening to international shortwave broadcasts has been an enjoyable and educational avocation for many people over the years. A great number of countries spend a substantial amount of their SW budget on English-language programs that are beamed or relayed to the U.S., so there's plenty of interesting fare to hear from foreign countries. And though the word "shortwave," which covers frequencies from about 0.2 to 30 MHz, conjures up ham radio in the public's mind, no license of any sort is needed to listen to these frequencies.

Although shortwave receivers are easier to use now that digital frequency readouts and more advanced frequency-stabilizing circuits have been introduced, the operating process and reception quality still do not approach the high performance we're used to with AM and FM radios. As a result, shortwave listening is not a mass-market activity in our country. (It is common in many other countries, though.)

One still has to have a hobbyist spirit to some extent to participate in SWL, even with new operating enhancements, smaller equipment size and lower cost. A handful of hurdles exist for the general public. For example, reception of SW broadcast signals (most of which have to travel thousands of miles) depend on the time of day in which they're sent, the season of the year, signal strength, antenna quality, sunspot activity, signal jamming, multipath-induced signal fading and atmospheric interference.

Furthermore, one has the additional challenge of following seasonal and broadcast frequency changes that are necessarily made by broadcasters to achieve optimum transmission times according to season. Then, you have to follow the times that programs broadcast in English, assuming this is what you want, or Spanish, etc. Time in UTC, using the 24-hour clock, is another obstacle for the general public at this time.

You'd think that in this day and age, there would be enough improvements in transmission and reception equipment and techniques to circumvent many of these deficiencies. Sure the best SW re-

ceivers have variable notch filters, variable automatic gain control circuitry, pulse noise eliminators, etc. But how many people want to bother with all this unless they're especially anxious to get different foreign news perspectives, theatre skits, music, QSL souvenir cards, soccer game scores, etc. Except when tuning in during a foreign war or natural catastrophe, most people in the U.S. are simply not willing to trade off some effort and audio quality for these free intellectual gains.

Along these lines, there is serious talk about using satellites to provide direct broadcast of sound programs to overcome deficiencies in shortwave broadcast signals, in area coverage, and limited availability of more internationally agreed-upon broadcast frequency slots. The World Administrative Radio Conference (WARC) held this year agreed that work on the direct broadcast satellite audio (DBS-A) system should be speeded up. Such a service would revolutionize international SW broadcasts and reception.

Suggestions relating to the DBS-A include changing modulation from its present AM mode to FM or digital. Characteristics of such a system would make it possible to greatly increase the number of SW channels, permit use of low-power, low-cost transmitters of only 5 kW, and provide a service reliability of 99.9%. Furthermore, receivers required to pick up such transmissions would be very inexpensive, and small pointable antennas could be used.

With more than 100 nations broadcasting on the SW bands today, it won't be an easy task getting 'em all together to change the present shortwave broadcast system. But it can't come soon enough. International broadcast shortwave listeners have been getting the short stick long enough!

*Art Salsberg*

## HAM RADIO IS FUN!

It's even more fun for beginners now that they can operate voice and link computers just as soon as they obtain their Novice class license. You can talk to hams all over the world when conditions permit, then switch to a repeater for local coverage, perhaps using a transceiver in your car or handheld unit.



Your passport to ham radio adventure is TUNE-IN THE WORLD WITH HAM RADIO. The book tells what you need to know in order to pass your Novice exam. Two cassettes teach the code quickly and easily.

Enclosed is my check or money order for \$15.00 or charge my

( ) VISA ( ) Mastercard ( ) Am. Express

Signature \_\_\_\_\_

Acct. No. \_\_\_\_\_

Good from \_\_\_\_\_ Expires \_\_\_\_\_

Name \_\_\_\_\_

Address \_\_\_\_\_

\_\_\_\_\_

City \_\_\_\_\_ State \_\_\_\_\_ Zip \_\_\_\_\_

THE AMERICAN RADIO RELAY LEAGUE  
225 MAIN ST.  
NEWINGTON, CT 06111

CIRCLE 46 ON FREE INFORMATION CARD

July 1989 / MODERN ELECTRONICS / 7



**THE "HELP PHONE"™.** NEC Home Electronics moves into the home safety field with the intro of its Help Phone. The phone is equipped to provide automatic dialing to the proper emergency assistance organization through NEC's own nationwide central alarm agency. The UL-listed service is staffed 24 hours per day, every day. The Phone can be triggered by a smoke detector's sound or by manual operation of illuminated color-coded emergency memory dialing buttons.

An automatic crisis call for police, fire department or medical service consists of the owner's account number, type of emergency, and a 15-second digitally recorded message of the owner's voice. There's a four-hour battery backup and a low-battery indicator. Various options are offered for the Help Phone and for the national Help Center. The top-of-the-line Phone among three telecommunications models available is equipped with a hand-held digitally coded remote control that operates at a distance up to 150 ft. from the Help Phone, for example. Phone prices range from \$119 to \$299. Help Center monitoring costs are estimated to be only \$60 per year for basic service and \$75 for extended service. Consumer inquiries are being taken at 1-800-366-3632.

**EURO-SINO PARTNERSHIP.** BASF Corp. and Fuji Photo Film U.S.A. look to the future ascendancy of 3.5-inch diskettes by entering a joint partnership to build a manufacturing facility in Bedford, MA to produce themicro floppies. The firm will be known as B & F Microdisks, which is expected to create 230 new jobs. An estimated 90-million diskettes annually are to be produced.

**THE MORSE CODE FRONT.** The ARRL recommended creating a class of Amateur Radio license that doesn't require knowing Morse code. It proposes a somewhat more comprehensive written examination for this new license, while eliminating a Morse code exam. Operating priviliges would be the same as that of Technician above 30 MHz, except that 2-meter frequencies would be limited to 144.9-145.1 MHz and to digital modes only.

On another American Radio Relay League front, the ARRL initiated a new project to develop the next generation of modems and protocols for high-frequency packet radio transmission. It plans to coordinate amateur radio designer efforts and to make modest funding available for approved out-of-pocket expenses relating to prototype development, though not labor or overhead. For more information, contact Lori Weinberg at 203-666-1541.

NARA (National Amateur Radio Association) is distributing a new shareware program called Super Morse, written by Lee Murrah, WD5CID. It's for use with an IBM or compatible computer. The program is organized into learning characters, building speed, enhancing skills and measuring progress. It has two unique code-practice features: two users can practice receiving code over the phone line, and an interactive mode permits using a modem to generate the code sound of a letter or figure at the receiver end of the phone call when its key is typed by the sender. For a free copy, send \$3 postage/handling to NARA, 16541 Redmond Way, Suite 232, Redmond, WA 98052.



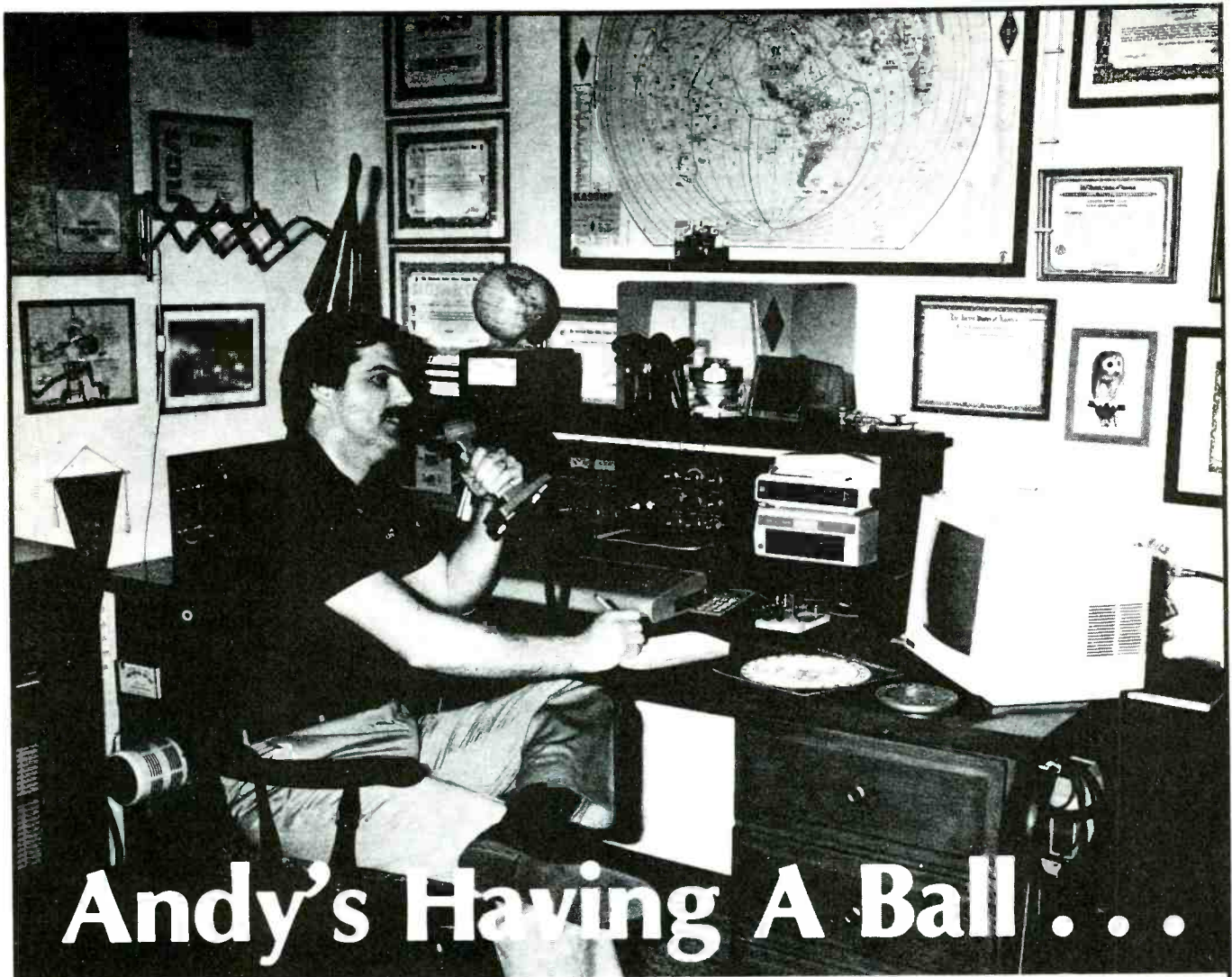

# Andy's Having A Ball . . .

## and you can too!

Andy is a Ham Radio operator and he's having the time of his life talking to new and old friends in this country and around the world.

You can do it too! Join Andy as he communicates with the world. Enjoy the many unique and exclusive amateur bands . . . the millions of frequencies that Hams are allowed to use. Choose the frequency and time of day that are just right to talk to anywhere you wish. Only Amateur Radio operators get this kind of freedom of choice. And if it's friends you're looking to meet and talk

with, Amateur Radio is the hobby for you. The world is waiting for you.

If you'd like to be part of the fun . . . if you'd like to feel the excitement . . . we can help you. We've got all the information you'll need to get your Ham license. Let us help you join more than a million other Hams around the world and here at home. Who are we? We're the American Radio Relay League, a non-profit representative organization of Amateur Radio operators.

For information on becoming a Ham operator  
circle number 110 on the reader service card or write to:

**AMERICAN RADIO RELAY LEAGUE**

Dept CQ, 225 Main Street  
Newington, Conn. 06111.

This space donated by this publication in cooperation with the American Radio Relay League.

For more information on products described, please circle the appropriate number on the Free Information Card bound into this issue or write to the manufacturer.

## Hand-Held Multimeters

Hewlett-Packard Co., well known as a manufacturer of calculators, computers and sophisticated laboratory test equipment, is now marketing a line of low-cost hand-held multimeters. Three models make up the line. All offer audible continuity testing, diode testing, automatic ranging with manual override, an analog/digital display and the ability to measure resistance and ac and dc voltage and current. Maximum input is 1,000

volts dc, 750 volts ac and 10 amperes ac and dc.

The low-end Model HP E2373A offers a basic accuracy of 0.7% and the basic multimeter functions. The more expensive Models HP E2377A and HP E2378A add a built-in temperature-measuring and data-hold functions and boost the dc accuracy to 0.3%.

Specifications common to all three models include: 3½-decade display for 3,200 count; 2% (HP E2373A) and 1% (HP E2377A and HP E2378A) basic accuracy; 500 Hz (HP E2373A) and 1 kHz (HP E2377A and HP E2378A) maximum bandwidth. The multimeters feature tough polycarbonate cases with built-in tilt



stand, with the middle- and top-of-the-line models adding gasketing and water resistance, respectively. Temperature probes and soft carrying-case accessories are available for the latter two models. \$99 (HP E2373A); \$169 (HP E2377A); \$189 (HP E2378A).

CIRCLE 26 ON FREE INFORMATION CARD

## Portable Printer

Kodak's portable Diconix 150 Plus printer, an enhanced version of the original 150, is designed to be a logical companion to laptop computers. It offers improved text and graphics quality, 20% faster output and can print on plain paper. The printer can use single-sheet or continuous-feed computer paper and can print at speeds up to 180 characters per second in draft mode.

Printing resolution is 192 dots per inch. New fonts have been created for this printer. Both 10-pitch pica and 12-pitch elite type sizes are available, yielding a choice of 70 or 85 characters per 7" line. Also, the number of international character sets has been expanded from 8 to 14, any of which can be selected by changing an internal DIP switch. A font switch now allows fonts to be selected from the front panel using the DIP switch and LED indicators. Draft, near-letter quality, condensed and superscript/subscript modes are built in and are selectable from the operator panel or under software control.

Emulations are provided for the IBM Proprinter and Epson FX-series printers, with single-, double- and



quad-density graphics capability. Selection of either emulation permits printing an entire image condensed to fit the 7" printing width area (normal graphics mode) or full-size with 1" truncated from the right side of the image (expanded graphics mode).

A wider slot for paper exit permits 9.5" continuous form paper to be fed into the printer with the cover closed. Also, a new ink formulation is said to improve image quality on plain paper. The replaceable ink-jet print-

head cartridge is rated to print 300 to 500 pages of text.

The printer uses rechargeable C cells and can print about 150 pages before requiring recharging. Software senses when data is being received, halts charging to permit printing and then resumes when printing is done. The printer measures 10.8"W × 6.5"D × 2"H and measures just 3.1 lb. \$499 with parallel interface; \$519 with serial interface.

CIRCLE 27 ON FREE INFORMATION CARD



## Video-To-Go

A portable VHS VCR with a 4" color LCD video monitor has been introduced by Sharp Electronics. The Model VC-V540U TV/VCR combo is designed for both indoor and outdoor use and can be operated from ac or dc sources. It uses full-size VHS videocassettes. Audio/video input



jacks connected to a separate tuner permit reception and recording of TV broadcasts.

The 4" diagonal video monitor screen incorporates a Thin Film Transistor (TFT) Active Matrix System that controls 115,200 picture elements (color-dot pixels) for high image clarity with vibrant colors.

Built into a compact, rugged cabinet with integral handle, the Model VC-V540U measures 11 $\frac{5}{8}$ "W x 10"H x 4 $\frac{1}{6}$ "D. \$1,899.95.

CIRCLE 28 ON FREE INFORMATION CARD

## Conductive-Ink Pen

Planned Products (Los Gatos, CA) has a low-cost pen that can be used for applying a highly-conductive solderable silver ink on most surfaces for electronics work. With this pen, one can quickly repair a printed-cir-



cuit board or even free-hand draw traces on an unclad circuit-board blank or other surface. It can also be used to apply shielding and conductive point-to-point traces.

The pen has a valved tip that permits smooth application of the liquid silver conductor. Normal writing pressure opens the valve tip to allow the liquid silver to flow like an ordinary ink onto the material being used as the substrate. Traces as narrow as  $\frac{1}{16}$ " can be drawn. The polymer ink with which the pen is filled dries in minutes at room temperature and is claimed to be several times more conductive than solder (resistivity is rated at 0.03 to 0.05 ohm per square mil). When the pen is not in use, spring action closes the tip valve to prevent the liquid silver from drying out. The pen comes with enough ink to make 150 feet of  $\frac{1}{16}$ "-wide conductor traces.

Solderable traces are possible using a 250° F cure for 10 to 15 minutes after applying the ink to the substrate. Tin, lead and silver solder can be used to make soldered connections but the soldering heat used should not exceed 350° F for more than 5 seconds. \$10.05.

CIRCLE 29 ON FREE INFORMATION CARD

## Portable CD Player

An ultra-compact, lightweight portable CD player that offers normal, resume and random play modes has been announced by Technics. Power for the Model SL-XP player can be an internal rechargeable battery, car battery or an ac adapter. In resume mode, the player resumes playing from the start of the track that was playing when-power was shut off. An on-board microprocessor shuffles the order of selection play in the random-play mode.

For extra flexibility, skip and memory keys allow for 18-step random-access programming. In addition to local control, the play, stop and skip-forward functions can be accessed from a wired remote-con-

# ATTENTION VCR TECHNICIANS



### VCR REPAIR PARTS KIT

Now you can do most of your VCR repair jobs the **same day**. Parts Express VCR Parts Kit makes this possible. It contains over 45 of the most commonly used parts to repair RCA, Hitachi, Fisher, Sanyo, Lloyds, Panasonic, Sony, Sharp, JVC, Samsung, TMK, GE, Magnavox and more. Idler assemblies, pinch roller, sensing transistors, switches, and lamps are included in this comprehensive kit. You also save over \$20.00.

Kit contains replacements for: Sharp (2) NIDL0005 (2) NIDL0006 (1) NPLY-V0051 Panasonic (2) VXP0329 (2) VXP0401 (2) VXP0344 (2) VXP0521 RCA (1) 150614 (1) 164113 (1) 150650 Hitachi (1) 641311 Fisher/Sanyo (1) 143 0-4204 00300 (2) 143-0-4804-00100 (1) 143-0-4904 00900 (1) 143-0-7411-20002 RCA/Hitachi (2) up/down switch (5) 161757 sensing transistors Panasonic lamps (2) XAM022P150W (5) XAMV0019 (5) XAMV125 (1) Molybdenum grease. Normal dealer cost of over \$110.00. (All parts are available individually for reorders.)

Order #  
400-950

**\$89.95**  
Plus shipping



### VCR IDLER TIRE KIT

This popular kit contains 150 of the most popular idler tires (10 each of 15 different sizes). With this kit in your stock room, you can do over 90% of VCR repair jobs the same day, saving time and money! Also included is our comprehensive cross reference listing over 80 manufacturers' assembly numbers and over 200 model numbers. A \$400.00 retail value. (All tires are available individually for reorders.)

Order #  
400-900

**\$55.00**  
Plus shipping

FREE  
CATALOG



**Parts  
Express**  
International Inc.

CALL TOLL FREE  
**1-800-338-0531**

340 E. First St., Dayton OH 45402  
Local—1-513-222-0173

CIRCLE 18 ON FREE INFORMATION CARD

## NEW PRODUCTS...



control unit located on the headphone cord. Internal power can be from supplied rechargeable Ni-Cd cells or two AA cells (not included). An ac adapter is provided for recharging the Ni-Cd cells while inside the player.

A quadruple oversampling digital filter (176.4 kHz) is said to provide

realistic sound quality and superior stereo imaging. Other features include: automatic power off after 5 minutes in the stop mode; headphone level control; repeat, skip and search keys; line output jack; and die-cast aluminum case. An LCD panel displays total number of tracks, total playing time of the disc, track number in play, elapsed playing time, repeat, program, play mode (resume/random) and battery condition.

The player is housed inside a die-cast aluminum case. It measures 5½"D × 4½"W × 1½"H and weighs 13.4 oz. \$349.

CIRCLE 30 ON FREE INFORMATION CARD

### *Sleep Alert for Drivers*

The Drive Alert™ from Softrade Inc. (Claremont, CA) is a sleep warning device for motor vehicle drivers. It is designed to help guard against falling asleep at the wheel while driving. Fitting behind an ear, much like a hearing aid, Drive Alert emits a 2-kHz, 86-dB warning tone if the driver nods his head past a certain angle. The angle at which the device sounds its alert is user selectable from among 18 provided positions. The user can adjust the device to take into account his normal posture while driving.

The shape of the 0.5-ounce device

### *Portable PC*

Toshiba's new Model T5200 laptop PC is designed for applications that require high-end desktop performance and internal expansion capabilities. The 80386-based laptop is available in two models that differ from each other only in hard-disk capacity (40 or 100 MB). Two expansion slots are available—a full-length 16-bit and a dual-function half-length 8-bit or Toshiba 16-bit slot that accepts both standard and Toshiba-sized enhancement cards.

Features include: 80386 CPU operating at 20 MHz; 82385 controller with 32K of high-speed static RAM cache; 80387-20 math coprocessor socket; 2 MB RAM (expandable to 8 MB total); 40-MB, 29-ms or 100-MB, 25-ms hard disk; 1.44-MB 3.5" floppy drive; built-in VGA system with high-resolution gas plasma display with 16-level gray scale and 640 × 480-pixel graphics; VGA color monitor port; full-size keyboard with 91 keys (101-keyboard compatible) with separate cursor and numeric keypad; two nine-pin RS-232C serial ports; selectable parallel printer/external 5.25" diskette drive port; a combination lock that latches the screen closed over the keyboard; security tab to cable the system to a desk or table top.



Software packaged with the computer include MS-DOS 3.3, PC-Kwik Power Pak disk cache utilities and QEMM-386 memory-management software. Hypertext on-line, disk-resident T5200 Reference and DOS manuals complement the system's portability by eliminating the need to carry manuals (printed documentation is included).

Available options include memory modules, an internal 2,400-bps

Hayes-compatible modem (\$399) and an external 5.25" floppy-disk drive (\$499) and Floppy Link (\$199). An optional expansion chassis with five IBM-compatible slots (\$999) and chassis interface card (\$199) provide a means for greater expansion.

The computer measures 15.6"D × 14.6"W × 3.9"H and weighs 18.7 lb. \$9,499 with 40-MB hard disk; \$10,999 with 100-MB hard disk.

CIRCLE 32 ON FREE INFORMATION CARD



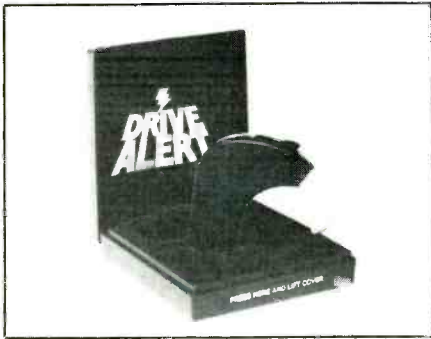

is said to accommodate all ear contours. Drive Alert can be worn on either ear, with or without eyeglasses. It comes in an adhesive-backed storage container that can be conveniently affixed to the dashboard of the user's vehicle, where the device will be ready for use at all times. \$19.95.

CIRCLE 19 ON FREE INFORMATION CARD

### Digital Trainer

The Model XK-220 digital trainer from Elenco Electronics, Inc.



(Wheeling, IL) is designed to help the student and hobbyist get hands-on training to see how digital theory works. The trainer permits circuits to easily be assembled and wired on its 590-point solderless breadboarding block and 100-point breadboarding strips. Three power supplies, eight data switches, two logic switches and eight logic indicators are built in. Self-contained in its own carrying case with component/parts box attached to the lid, the trainer comes with complete instructions and circuit descriptions. You add the solid-state devices, passive components and wires. \$150 factory wired; \$110 kit.

CIRCLE 31 ON FREE INFORMATION CARD

### Portable Spectrum Analyzer

A new portable 1-GHz spectrum analyzer, the Model PSA-65A, has been introduced by AVCOM of VA, Inc. (Richmond, VA). The instrument covers frequencies through 1,000 MHz in one sweep with a sensitivity that is claimed to be greater than -90 dBm at narrow spans. Options include frequency extenders that enable the analyzer to be used at Satcom and higher frequencies, audio demodulator for monitoring,

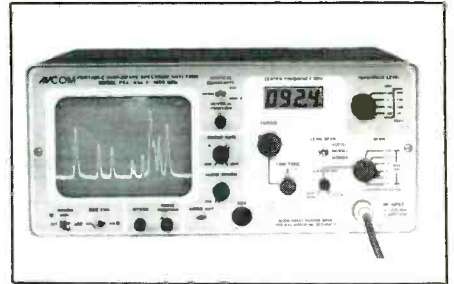

log-periodic antennas, carrying case, etc. The analyzer measures 13.5"D x 11.5"W x 5.5"H and weighs 18 lb. \$2,675.

CIRCLE 8 ON FREE INFORMATION CARD

## HITACHI SCOPES AT DISCOUNT PRICES

<p><b>V-212</b> <b>\$419</b> List \$560 Save \$141</p> <p><b>20MHz Dual Trace Oscilloscope</b> All Hitachi scopes include probes, schematics and Hitachi's 3 year warranty on parts and labor. Many accessories available for all scopes.</p>	<p><b>V-425</b> List \$995 <b>\$835</b></p> <ul style="list-style-type: none"> <li>• DC to 40MHz</li> <li>• Dual Channel</li> <li>• CRT Readout</li> <li>• Cursor Meas</li> <li>• DC Offset</li> <li>• Alt Magnifier</li> <li>• Compact Size</li> </ul>	<p><b>V-1060</b> List \$1595 <b>\$1,325</b></p> <ul style="list-style-type: none"> <li>• DC to 100MHz</li> <li>• Dual Channel</li> <li>• Delayed Sweep</li> <li>• CRT Readout</li> <li>• Sweep Time</li> <li>• Autoranging</li> <li>• Trigger Lock</li> <li>• 2mV Sensitivity</li> </ul>
<p>V-223 20MHz D.T. 1mV sens. Delayed Sweep, DC Offset, Vert Mode Trigger \$170 \$695 \$75</p> <p>V-422 40MHz D.T. 1mV sens. DC Offset, Vert Mode Trigger, Alt Mag \$875 \$125 \$150</p> <p>V-423 40MHz D.T. 1mV sens. Delayed Sweep, DC Offset, Alt Mag \$955 \$825 \$130</p> <p>V-660 60MHz D.T. 2mV sens. Delayed Sweep, CRT Readout \$1195 \$1025 \$170</p> <p>V-1065 100MHz D.T. 2mV sens. Delayed Sweep, CRT Readout, Cursor, Meas \$1895 \$1670 \$225</p> <p>V-1100A 100MHz D.T. 1mV sens. Delayed Sweep, CRT Readout, DVM, Counter \$2295 \$2045 \$250</p> <p>V-1150 150MHz D.T. 1mV sens. Delayed Sweep, Cursor Meas, DVM, Counter \$3100 \$2565 \$535</p>		

## ELENCO PRODUCTS AT DISCOUNT PRICES

<p><b>20MHz Dual Trace Oscilloscope</b> <b>MO-1251</b> <b>\$359</b></p> <ul style="list-style-type: none"> <li>• 6" CRT</li> <li>• Built in component tester</li> <li>• TV Sync</li> <li>• X-Y Operation</li> </ul>	<p><b>FREE DMM</b> with purchase of MO-1251/1252 Scope</p> <p><b>SCOPE PROBES</b> P-1 65MHz 1x, 10x \$19.95 P-2 100MHz 1x, 10x \$23.95 Fits all scopes with BNC Connector</p>	<p><b>35MHz Dual Trace Good to 50MHz</b> <b>MO-1252</b> <b>\$495</b></p> <ul style="list-style-type: none"> <li>• High luminance 6" CRT</li> <li>• 1mV Sensitivity</li> <li>• 6KV Acceleration Voltage</li> <li>• 10ns Rise Time</li> <li>• X-Y Operation • Z Axis</li> <li>• Delayed Triggering Sweep</li> </ul>		
<p><b>Autoranging DMM</b> <b>M-5000</b> <b>\$45</b></p> <p>9 Functions Memory and Data hold 1/2% basic acc 3 1/2 digit LCD</p>	<p><b>True RMS 4 1/2 Digit Multimeter</b> <b>M-7000</b> <b>\$135</b></p> <p>0.5% DC Accuracy 1% Resistance with Freq. Counter and deluxe case</p>	<p><b>Multimeter with Capacitance and Transistor Tester</b> <b>CM-1500</b> <b>\$55</b></p> <p>Reads Volts, Ohms, Current, Capacitors, Transistors and Diodes with case</p>	<p><b>Digital Capacitance Meter</b> <b>CM-1550</b> <b>\$58.95</b></p> <p>9 Ranges 1pf-20,000ufd 5% basic acc Zero control with case</p>	<p><b>Digital LCR Meter</b> <b>LC-1801</b> <b>\$125</b></p> <p>Measures Coils 1uH-200H Caps. 1pf-200uf Res. 0.1-20M</p>
<p><b>AC Clamp-On Current Adapter</b> <b>ST-265</b> <b>\$22</b></p> <p>0-1000A AC Works with most DMM</p>	<p><b>Bench DMMs</b> <b>M-3500</b> <b>M-4500</b> <b>\$125</b> <b>\$175</b></p> <p>3 1/2 digit 1% acy 4 1/2 digit 0.5% acy</p>	<p><b>SOLDERING STATION TEMPERATURE CONTROLLED</b> <b>SL-30</b> <b>\$135</b></p> <p>Digital display Temp range: 300F-900F Grounded hp Overheat prot</p>	<p><b>Solderless Breadboards</b> <b>9436 SHOWN</b></p> <p>9430 1,100 pins \$15 9434 2,170 pins \$25 9436 2,860 pins \$35 All have color coded posts</p>	<p><b>Low Cost Multimeter</b> <b>M-1600</b> <b>\$25</b></p> <p>3 1/2 digit LCD 1% DC Accy 10A Scale Auto zero/polarity</p>
<p><b>Wide Band Signal Generators</b> <b>SG-9000</b> <b>\$129</b></p> <p>RF Freq 100K-450MHz AM Modulation of 1KHz Variable RF output</p> <p><b>SG-9500 with Digital Display and 150MHz built-in Freq Ctr</b> \$249</p>	<p><b>3 1/2 Digit Probe Type DMM</b> <b>M-1900</b> <b>\$39</b></p> <p>Convenient one hand operation with batteries and case Measures DCV, ACV, Ohms Audible continuity check, Data hold</p>	<p><b>Function Generator</b> <b>Blox #9600</b> <b>\$28.95</b></p> <p>Provides sine, tri, squ wave From 1Hz to 1MHz AM or FM capability</p>	<p><b>Decade Blox</b> <b>9610 or 9620</b> <b>\$18.95</b></p> <p>#9610 Resistor Blox 47 ohm to 1M &amp; 100K pot #9620 Capacitor Blox 47pf to 10MFD</p>	
<p><b>Digital Triple Power Supply</b> <b>XP-765</b> <b>\$249</b></p> <p>0-20V at 1A 0-20V at 1A 5V at 3A</p> <p>Fully Regulated, Short circuit protected with 2 Limit Cont. 3 Separate supplies <b>XP-660 with Analog Meters \$175</b></p>	<p><b>Quad Power Supply</b> <b>XP-580</b> <b>\$59.95</b></p> <p>2-20V at 2A 12V at 1A 5V at 3A -5V at 5A</p> <p>Fully regulated and short circuit protected <b>XP-575 without meters \$39.95</b></p>	<p><b>10MHz XT 100% IBM® Compatible</b> <b>5 Year Warranty</b> <b>\$595</b> <b>MODEL PC-1000</b></p>		
<p><b>Four-Function Frequency Counters</b> <b>F-1000 1.2GH</b> <b>\$259</b> <b>F-100 120MH</b> <b>\$179</b></p> <p>Frequency, Period, Totalize, Self Check with High Stabilized Crystal Oven Oscillator, 8 digit LED display</p>	<p><b>GF-8016 Function Generator with Freq. Counter</b> <b>\$239</b></p> <p>Sine, Square, Triangle Pulse, Ramp, 2 to 2MHz Freq Counter: 1-10MHz <b>GF-8015 without Freq. Meter \$179</b></p>	<p><b>+5/10MHz Motherboard</b> +8 Expansion Slots +Math Compressor Slots +350K Floppy Drive +AT Style Keyboard</p> <p><b>+150W Power Supply</b> +256K RAM Expandable to 640K +Monochrome Monitor +Monographic Video Card +Parallel Printer Port</p> <p><b>FREE spreadsheet and word processor</b> 3.3MS DOS and GW Basic add \$75</p>		
<p><b>WE WILL NOT BE UNDERSOLD!</b> UPS Shipping: US 5% (\$10 Max) IL Res., 7% Tax</p>		<p><b>C &amp; S SALES INC.</b> 1245 Rosewood, Deerfield, IL 60015 (800) 292-7711 (312) 541-0710</p>		

CIRCLE 75 ON FREE INFORMATION CARD

# Easy Computerized Control and Monitoring

*An economical way to monitor sensors and actuate electrically operated devices using a computer, external controller and a BASIC language interpreter*

By Daniel N. Eggert

Personal computers can be used for a wide variety of things other than processing words and crunching numbers. For example, they can be used as monitoring and controlling devices for a home or business security system or as climate controllers. Model railroaders can use their computers to automate their layouts. Computers can also be used during the Christmas season to control lighting displays. In fact, there is almost no end to what you can control with a personal computer.

How you go about achieving control of electrically powered devices and appliances with a computer is rarely as simple as thinking up applications. And if you go the commercial hardware/software route, you can almost certainly bet on fairly high prices for the hardware and software needed to accomplish such control. With the hardware controller described here and a BASIC language interpreter, however, the cost can be kept reasonably low.

Unlike many commercial controllers, the one described here does not occupy a slot in your computer. Instead, it works through one of the serial ports on your computer. Connection between controller and computer is via a simple three-conductor cable that carries the receive-data, transmit-data and ground lines. Ad-

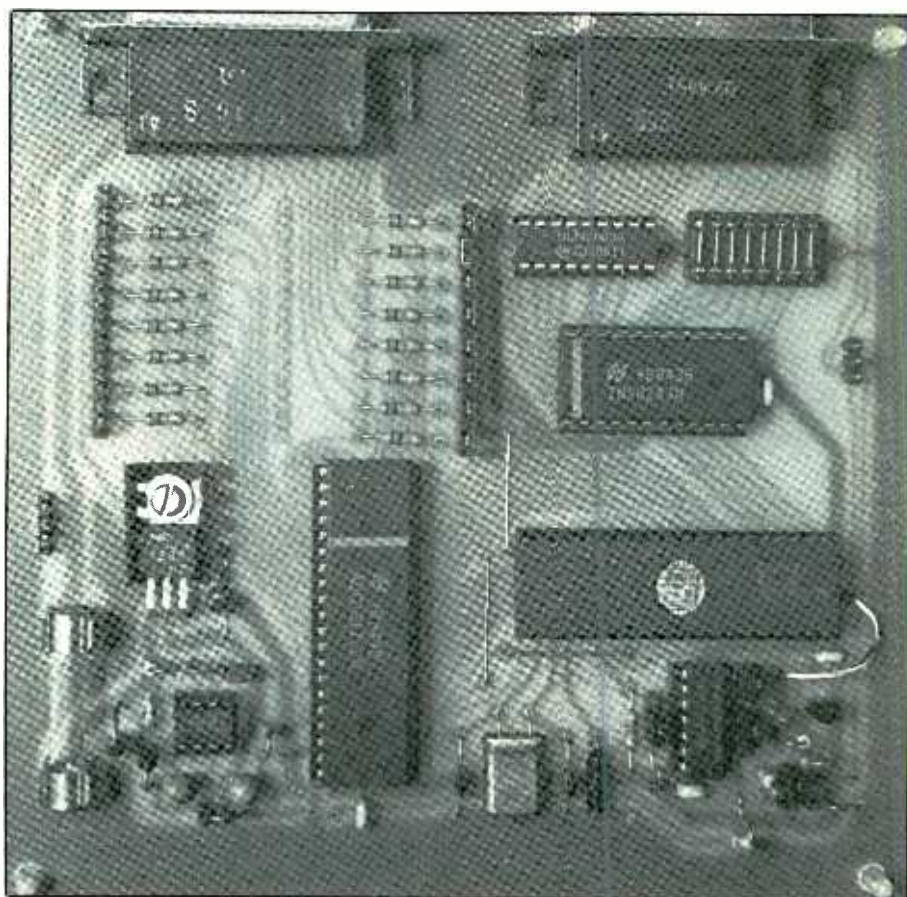

ditionally, the project has its own ac-operated power supply. Thus, the controller can be located remotely from the computer, closer to any sensors that must be monitored and devices that must be actuated.

Accompanying the controller project is a test fixture and an operating BASIC program for it. This test fix-

ture can be used as an aid to understanding programming and operation of the controller.

Many input/output configurations are possible with the 16 eight-bit analog inputs and 16 digital I/O

*Fig. 1. Complete schematic diagram of controller circuitry.*



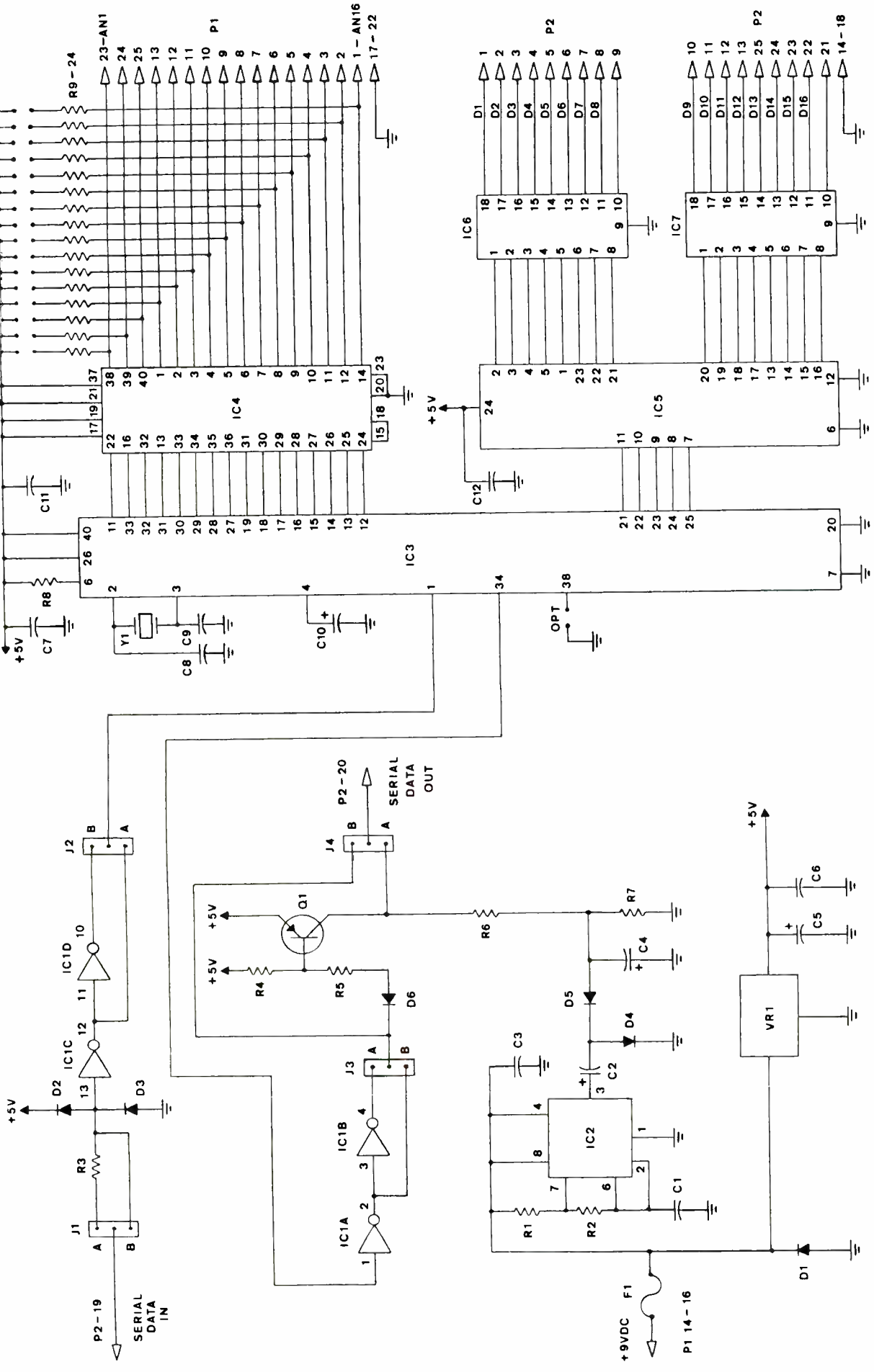

lines on the controller. The analog inputs can also be used as digital inputs in applications where a large number of digital inputs are required. The 16 digital/O lines can be split into two eight-bit ports, each of which can be used as either input or output.

The controller is designed to respond to 10 input/output commands that can easily be generated within a BASIC program. Detailed examples on how to generate BASIC command statements are included here to help you get the project up and running.

### About the Circuit

Use of an 8748 single-chip microcomputer that takes the place of many individual logic chips that would otherwise have been required made it possible to produce the simple circuit design shown in Fig. 1. Microcomputer chip *IC3* is the heart of the circuit. One of the functions of this chip is to emulate a UART configured to transmit and receive at 1,200 baud with no parity, eight data bits and one stop bit. It waits for an eight-bit command byte, receives the byte and then decodes and executes the command represented by the byte.

Another function of *IC3* is to control 16-channel multiplexed eight-bit analog-to-digital (A/D) converter *IC4*. The analog inputs are connected to the controller via plug *P1*. Pull-up resistors *R9* through *R24* are provided for the analog input lines. These resistors can be jumpered to the +5-volt bus when an analog input is used as a simple digital input with a switch or relay-contact closure. Two commands read the eight upper and eight lower analog inputs as though they were digital inputs.

Input/output expander *IC5* is also controlled by *IC3*. The digital lines from *IC5* are split into two eight-bit ports. Each eight-bit port can be either an input or an output. If the first eight digital I/O lines are to be used as outputs, *IC6* must be installed in the controller circuit. Integrated cir-

#### Semiconductors

D1,D4,D5—1N4004 silicon rectifier diode  
 D2,D3,D6—1N914 or similar silicon signal diode  
 IC1—74LS04 hex inverter  
 IC2—555 timer  
 IC3—8748 single-chip microcomputer (must be programmed—see Note below)  
 IC4—ADC0817 multiplexed 8-bit analog-to-digital converter  
 IC5—8243 input/output expander  
 IC6,IC7—ULN2803A Darlington array  
 Q1—2N3906 or similar silicon pnp transistor  
 VR1—7805 +5-volt fixed regulator

#### Capacitors

C1—0.01- $\mu$ F ceramic disc  
 C2,C4,C5—10- $\mu$ F, 15-volt electrolytic  
 C3,C6,C7,C11,C12—0.1- $\mu$ F ceramic disc  
 C8,C9—22-pF ceramic disc  
 C10—10- $\mu$ F, 15-volt electrolytic

#### Resistors (1/4-watt, 10% tolerance)

R1—1,500 ohms  
 R2,R4,R9 thru R24—10,000 ohms  
 R3—2,200 ohms  
 R5—2,700 ohms  
 R6—470 ohms  
 R7,R8—4,700 ohms

#### Miscellaneous

F1—1/4-ampere slow-blow fuse  
 P1,P2—DB-25S right-angle, pc-mount connector  
 Y1—6.000-MHz crystal with wire leads  
 Printed-circuit board or perforated board with holes on 0.1-inch centers

cuits *IC6* and *IC7* are Darlington transistor arrays whose output transistors are capable of sinking 500 milliamperes and will withstand up to 50 volts in the off condition. Maximum continuous power dissipation of a single Darlington pair is 1 watt, and total power dissipation for the complete IC is 2.25 watts. The Darlington arrays can directly interface to light-emitting diodes, relays and solid-state switching modules.

Each Darlington pair in *IC6* and *IC7* has an internal clamping diode,

### PARTS LIST (Controller)

and suitable Wire Wrap or soldering hardware (see text); suitable enclosure (see text); sockets or Molex Soldercons for all DIP ICs; 50 single-row male header pins; 20 shorting socket jumpers; two 16-pin male header plugs; 9-volt dc, 250-mA plug-in power supply and matching chassis-mount jack; pc clips for *F1*; machine hardware; hookup wire; solder; etc.

**Note:** The following items are available from D. Eggert, 3527 E. Edgemore Dr., Appleton, WI 54915: Silk-screened pc board, \$13; programmed 8748 microcomputer chip, \$14; 8740 assembly-language listing, \$5. Also available is a 5/8-inch diskette containing the test fixture BASIC program and machine-language call for TRS-80 Model I for \$5.00. Add \$1 per order for P&H. A home security system BASIC program on 5/8-inch diskette can be obtained for \$5 from B. Pelon, 1609 Grant St., Little Chanutte, WI 54140.

#### Parts Suppliers

##### Digi-Key Corp.

701 Brocks Ave. S.  
 Thief River Falls, MN 567-1-0677  
 1-800-344-4539

##### Jameco Electronics

1355 Shoreway Rd.  
 Belmont, CA 94002  
 415-592-8097

##### JDR Microdevices

110 Knowles Dr.  
 Los Gatos, CA 95030  
 1-800-538-5000

and all eight of these diodes have a common connection at pin 10 of the IC. The common leads of the clamping diodes are available at pins 9 and 21 of plug *P2* and can be used when driving relay coils.

To use eight digital I/O lines as inputs, a 16-pin header plug with jumpers from pin 1 to pin 18, pin 2 to pin 17, pin 3 to pin 16, etc., is installed in the circuit in place of *IC6* or *IC7*. The jumpers connect the I/O lines directly to plug *P2*, which is the digital I/O connector in this circuit. Installation



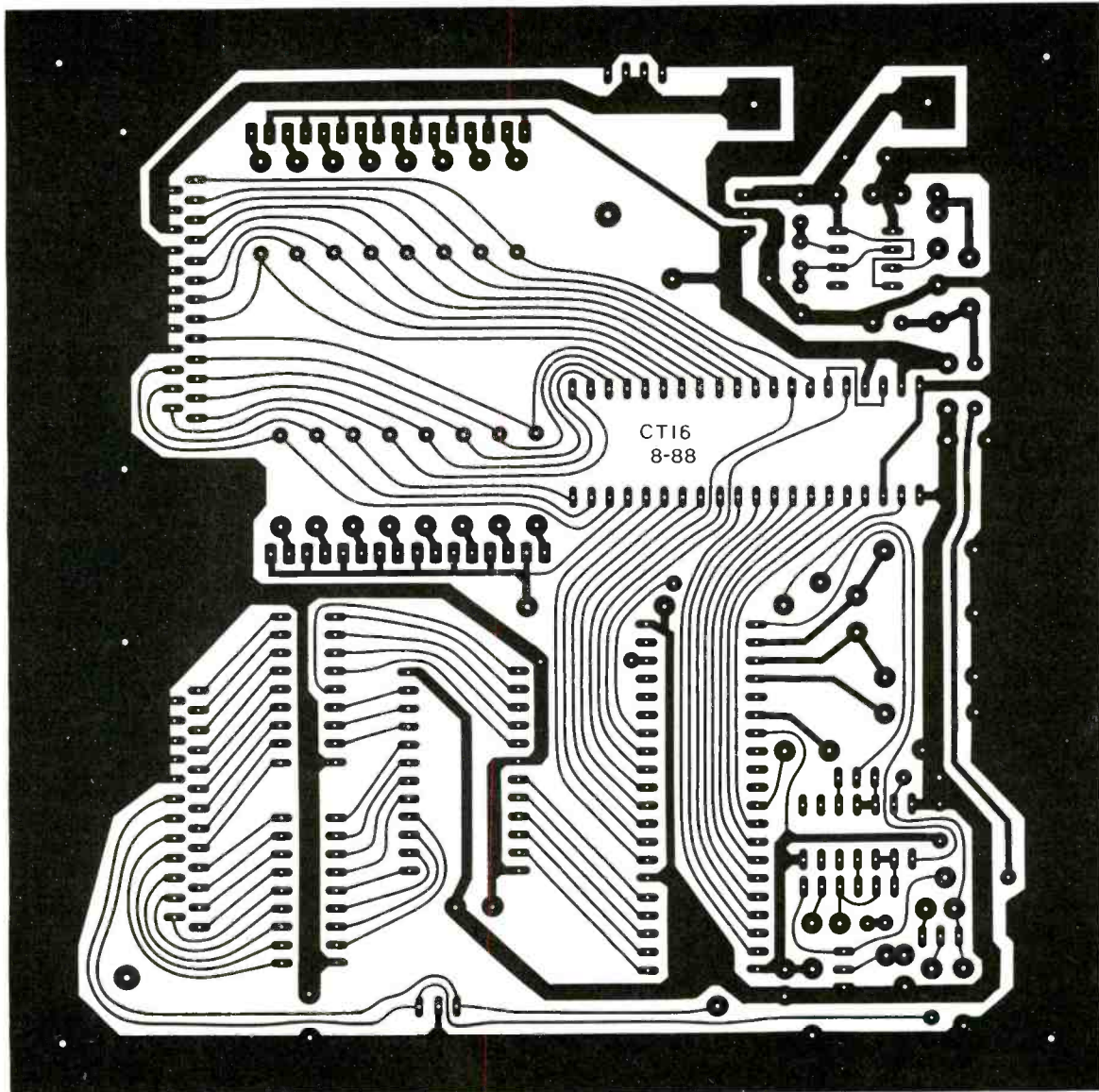

Fig. 2. Actual-size etching-and-drilling guides for top and bottom of double-sided printed-circuit board required for assembling project.

of this plug is in the uppermost portion of the IC socket, which leaves socket pins 9 and 10 unoccupied.

The serial interface circuitry is simple but versatile. Jumper options are provided in the circuit for receive and transmit data-line signal polarity and for TTL or RS-232 interfacing. When *J1* and *J4* are jumpered to position A, the interface is configured for RS-232 communication. When they are jumpered to position B, the interface is configured for TTL communication. Jumpers *J2* and *J3* per-

mit selection of signal polarity. For a typical RS-232 interface configuration, all four jumpers should be in position A.

The bipolar RS-232 output is +5 volts. The negative voltage for the RS-232 output option is generated by the *IC2* 555 timer circuit. The 555 timer is configured here to operate as a high-frequency astable multivibrator. Frequency of oscillation for this circuit is determined by the values selected for *C1*, *R1* and *R2*. Capacitor *C2* is charged through diode *D4*

when pin 3 of *IC2* goes high. When pin 3 goes low, *C4* partially charges through *D5*, diverting some of the charge from *C2*. After powering up the circuit, a few oscillator cycles are required to fully charge *C4*.

Serial data output at pin 34 of *IC3* goes to pin 1 of *IC1* for buffering and optional signal inversion. RS-232 output driver transistor *Q1* receives its input from pin 2 or pin 4 of *IC1*, which pin depending on option jumper *J3*. Diode *D6* in the input circuit of *Q1* ensures that the transistor

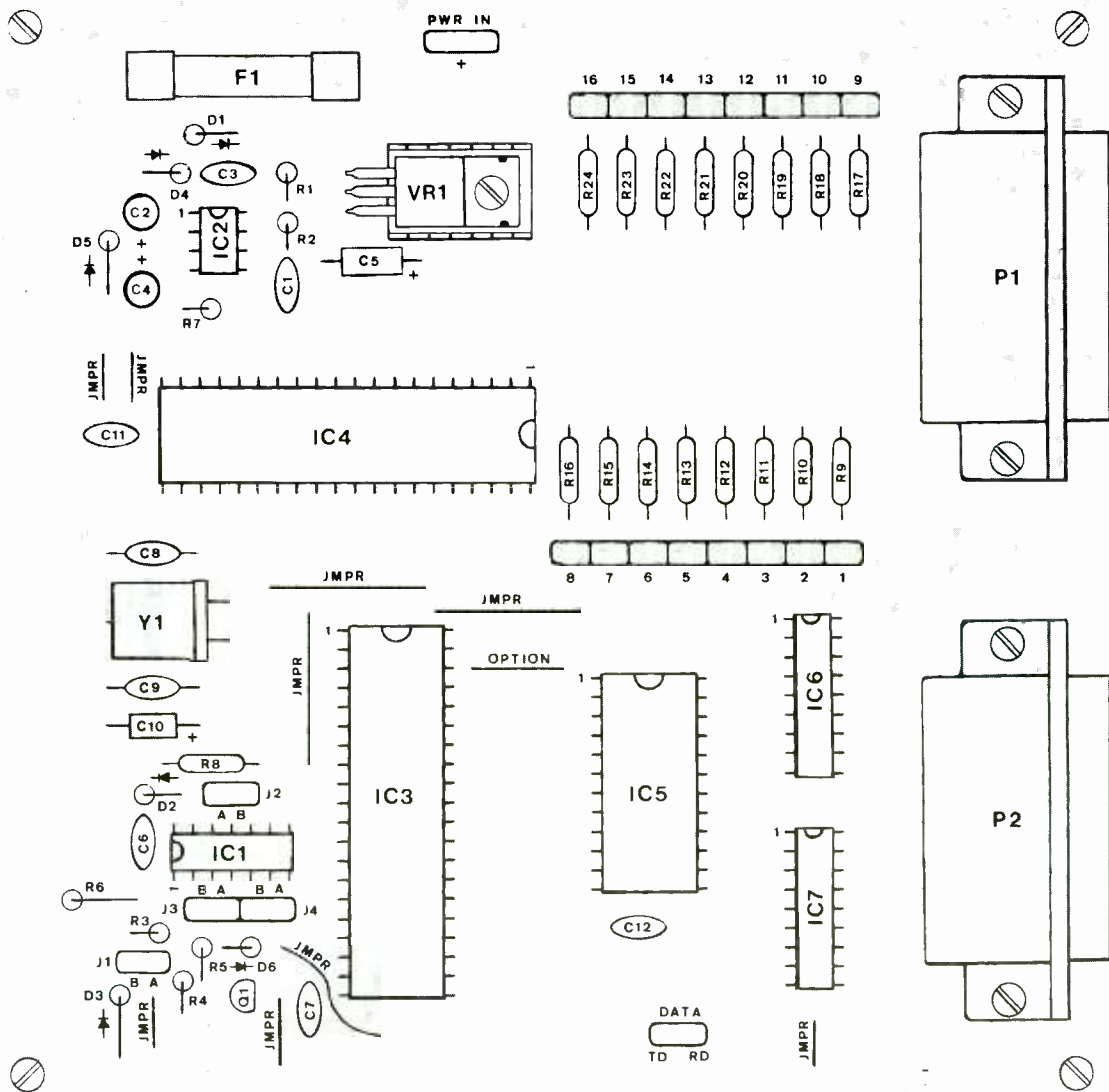

Fig. 3. Wiring diagram for pc board.

gets cut off when the output of *IC1* goes high. You can replace *D6* with a high-efficiency light-emitting diode and change the value of *R5* to 1,800 ohms if you wish to have a convenient activity indicator.

If option jumper *J4* position A is selected, the serial output data will be RS-232 compatible. Selecting position B for this jumper makes the output data TTL compatible.

Received serial data enters the circuit at pin 9 of *P2* and is routed directly to option jumper *J1*. Diodes

*D2* and *D3* and resistor *R3* make up a limiting circuit that converts the bipolar RS-232 input signal to a TTL level when option jumper is in position A. Option jumper *J1* is installed at position B when the incoming serial data is TTL compatible. The serial input is then buffered by *IC1* and is optionally inverted by jumper *J2*, after which it goes to pin 1 of *IC3*, where it is processed.

If you wish to expand the I/O capabilities of the project, you can use two controller boards in parallel. In

this event, the serial receive and transmit data lines must be connected in parallel and an option jumper must be connected from pin 38 of *IC3* to ground in one of the controller circuits. With this arrangement, when the most-significant bit (MSB) in the command byte is a logic 1, the controller with the option jumper installed will execute the command. When the MSB in the command byte is a logic 0, the controller without the jumper will execute the command.



Fuse *F1* and rectifier diode *D1* were designed into the circuit to prevent damage to the circuit in the event that the polarity of the input power is accidentally reversed. Fixed 5-volt regulator *VRI* easily handles the modest 90 milliamperes of current drawn by the circuit.

## Construction

Though you can build this circuit on perforated board that has holes on 0.1-inch centers using suitable Wire Wrap or soldering hardware, a printed-circuit board is highly recommended. You can fabricate your own board using the actual-size etching-and-drilling guide in Fig. 2 or purchase a ready-to-wire board from the source given in the Note at the end of the Parts List.

When you have the pc board ready to be wired, place it in front of you in the orientation shown in Fig. 3. Begin populating the board by installing and soldering into place the various jumpers, plugs and sockets for all DIP ICs. Do not install the ICs in their respective sockets until after preliminary voltage checks have been made.

Continue populating the board by installing and soldering into place the resistors, then the capacitors, diodes and transistor. Make certain before you solder any leads to the copper pads on the bottom of the board that the electrolytic capacitors and diodes are properly oriented and that the transistor is properly based.

Note in Fig. 3 that some resistors and all diodes mount on-end. The resistors that mount on-end are *R1* through *R7*. All other components mount flat against the top surface of the board.

If you decided to use the transmit-activity LED in your controller, omit diode *D6* and use an 1,800-ohm resistor for *R5*. Install the LED via 3-inch-long hookup wires attached to each lead and insulated with small-diameter heat-shrinkable tubing.

Make sure you install the LED in the *D6* holes in the same polarity as indicated for the diode before soldering the wires to the copper pads on the bottom of the board.

Bend the leads of the crystal at a 90-degree angle to one side of its case. Plug the leads into the appropriate holes in the board and push the crystal flat against the top surface of the board. Using heat judiciously, solder the leads of the crystal to the copper pads on the bottom of the board.

Install and solder into place the two clips for the fuse. When the clips cool, plug into them the fuse. Bend the pins of the voltage regulator at a 90-degree angle toward the rear of the case at the point where they just begin to widen. As mentioned above, there is no need to use a heat sink for the voltage regulator. However, if you decide to use one, use heat-transfer compound between the heat sink and regulator. Plug the pins of the regulator into the appropriate holes in the board and secure it in place with a 4-40 × ¼-inch machine screw, nut and lockwasher. Then carefully solder the pins of the regulator into place.

Finish up wiring the circuit-board assembly by installing and soldering into place the various wire jumpers. Regardless of how you configure the circuit, nine such jumpers must be installed. Use solid bare hookup wire or cut-off resistor leads for the short jumpers and insulated solid hookup wire for the long ones. Route the jumper wire that passes the lower-left corner of *IC3* as shown. Now install and solder into place any other jumper wires that will be required when the circuit is put into service.

As mentioned above, you can increase the I/O capabilities of the controller by using two circuit-board assemblies in parallel. If you are doing this, install the OPTION jumper wire shown in the center of Fig. 3 on only one board.

For the time being, place the head-

ers on the position A jumper pins for *J1* through *J4* so that they will not become lost.

Using heat judiciously, pool a small blob of solder on the top surface of the case of the crystal in line with the unoccupied hole in the circuit board. Pass one end of a bare hookup wire through the hole from the solder side of the board and bend it over the case of the crystal. Again using heat judiciously, solder the end of this wire to the case of the crystal using the solder you previously pooled on it. Then solder the other end of the wire to the copper pad on the bottom of the board and clip away any excess.

Except for installation of the DIP ICs in their respective sockets, this completes wiring of the circuit-board assembly.

You can use any type of enclosure that will comfortably accommodate the circuit-board assembly. If you can obtain one, a case that measures roughly 6½ inches square by about 1½ inches deep (2½ inches deep if you plan on housing two controller assemblies in the same enclosure) is ideal. Also, though you can use an all-metal enclosure for the project, it is better to use one that is mostly or all plastic to make it easier for you to make the cutouts for plugs *P1* and *P2*.

Begin machining the enclosure by placing the circuit-board assembly inside it and marking on its floor where to drill the four mounting holes for the board. Mark the locations of the slots for *P1* and *P2* (for both controllers if you built two and are housing them in the same enclosure). Also mark the location in which to drill the jack for the power supply you will be using. Locate this jack near where *F1* will be when the circuit-board assembly is mounted inside the enclosure.

Remove and set aside the circuit-board assembly. Then drill the four holes through the floor and jack hole through the side wall. Use whatever tools are necessary to carve out the two connector slots. Also, if you

have decided to use the LED activity indicator, drill a hole for it in a location where the LED will be easily seen with the project in operation. Replace the circuit-board assembly inside the enclosure and check that the connector slots are large enough and accurately located.

Before actually mounting the circuit-board assembly inside the enclosure, double check all component installations (except the DIP ICs, which should not be installed at this time) for appropriate values or types and orientations. When you are satisfied that all component installations are correct, turn over the circuit-board assembly and carefully examine it for missed solder connections, poorly soldered connections and inadvertent solder bridges, especially between closely spaced IC pads and conductors. Solder any missed connections and reflow the solder on any connection that appears suspicious. Use desoldering braid or a vacuum-type desoldering tool to remove solder bridges.

When you are certain that the circuit-board assembly is properly wired and soldered, mount it inside the enclosure using 1/4-inch metal spacers and 4-40 machine hardware or plastic pc board mounting clips. Then install IC2 in its socket; make sure it is properly oriented and that no pins overhang the socket or fold under between IC and socket.

Now prepare the cables that will interconnect the project with your computer. Prepare as many cables as needed, depending on whether you built one or two controller circuit-board assemblies. You can make each cable from scratch or start with already made up cables. Wiring details for the cables are shown in Fig. 4, one for using a DB-9S connector that goes to an AT or compatible computer and the other for using a DB-25S connector that goes to PC/XT or compatible computer. Only three conductors are required in either case, one for transmit, one for

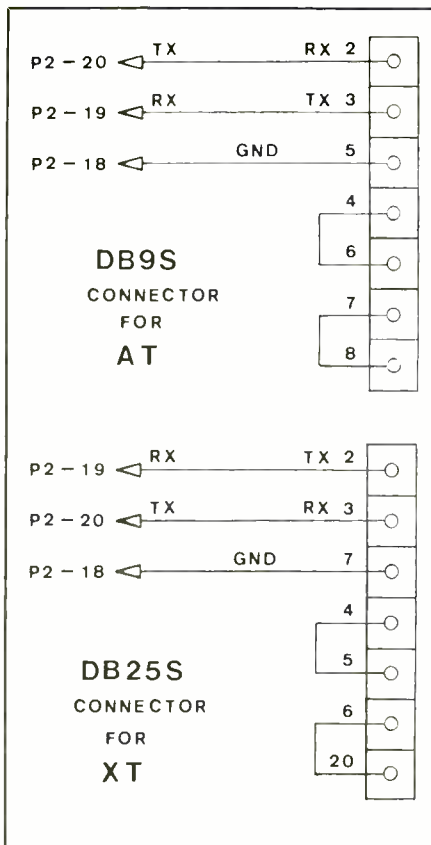

Fig. 4. Wiring diagrams for cable-to-connector hookups for DB-9 (upper) and DB-25 (lower) serial connectors.

receive and one for the common ground return. Choose the wiring arrangement that suits the particular computer you will be using with the controller project.

### Command Summary

Figure 5(A) graphically illustrates the bit positions of the variables in the following example BASIC statements. The first statement is an example of how command 1 is used:

```
PRINT #1,CHR$((CH-1)*4)+CN)
```

“Command Number” CN is bits 0 and 1 of the output command byte. Command Number 0 is not used. If CN=0, the controller will ignore the command if only one controller board is used and the OPTION jumper is not installed. If CN=1, the con-

troller will respond by sending back to the computer an analog input using “CH” as analog “CHannel” numbers 1 through 16.

In the above sample statement, 1 is subtracted from the channel number (CH) to convert it to a four-bit value from 0 to 15. It is also multiplied by 4 so that it occupies bit positions 2 through 5 in the output command byte. For command number 2, the variable OS is added to the BASIC statement in the following manner:

```
PRINT#1,CHR$((OS*64)
+ ((CH-1)*4)+CN)
```

If CN=2, the controller changes the state of a digital output using CH as digital output channel numbers 1 through 16.

OS is the “Output State.” If OS=0, the digital output addressed by CH is turned off, and if OS=1, it will be turned on. In the above statement, OS is multiplied by 64 so that it occupies bit position 6 in the output command byte.

After digital output command 2 is sent, the controller sends back to the computer an “ACK” code (6) to ACKnowledge that the command was received and executed. The above statement can be used for both commands 1 and 2. The OS variable is not used by analog input command 1, but it can remain in the statement. OS must be either 0 or 1.

The variable “MX” is now added to the BASIC statement as follows:

```
PRINT#1,CHR$(MX*128)+
(OS*64)+((CH-1)+CN)
```

Before decoding any commands, the controller always checks bit 7, which is the most-significant bit (MSB), to see if the command is to be executed or ignored. This depends on whether or not the jumper from pin 38 of IC1 to ground is installed.

MX is multiplied by 128 so that it occupies position 7 in the output command byte. MX must be either 0



$$((MX * 128) + (OS * 64) + ((CH - 1) * 4) + CN) \quad ((MX * 128) + ((SC - 1) * 4) + CN)$$



Fig. 5. Bit positions for variables in sample BASIC statements used in text.

or 1 if it is included in the statement.

The remaining eight commands will use the following BASIC statement example:

```
PRINT#1,CHR$((MX*128)+
(SC-1)*4)+CN)
```

Figure 5(B) graphically illustrates the bit positions of the variables in this statement. Variable SC, the "Sub Command," replaces CH in the previous statements and is sub-command statement numbers 1 through 8.

CN must equal 3 for all of the following eight sub-commands. In the above statement, 1 is subtracted from sub-command SC to convert it to a three-bit value from 0 to 7. It is also multiplied by 4 so that it occupies positions 2, 3 and 4 of the output command byte.

If SC = 1, the controller responds by reading the lower eight digital I/O lines as inputs and sends them to the computer as an eight-bit byte. If SC = 2, the controller reads and sends the upper eight lines.

If SC = 3, the controller responds by outputting the next byte that it receives to the lower eight digital I/O lines. If SC = 4, the controller outputs the next byte received to the upper eight I/O lines.

For sub-commands 3 and 4, the controller acknowledges the command byte and data byte by sending an ACK code (6) back to the computer after receiving each byte.

If SC = 5, the controller responds

by reading the lower eight analog inputs as if they were digital inputs and sends them to the computer as an eight-bit byte. If SC = 6, the controller reads and sends the upper eight analog inputs.

For sub-commands 5 and 6, if an analog input is greater than 2 volts, it will be a logic 1; if it is less than or equal to 2 volts, it will be a logic 0.

If SC = 7, the controller responds by reading the lower eight analog inputs and sends them to the computer as a string of eight consecutive bytes. If SC = 8, the controller reads and sends the upper eight analog inputs.

The ACK code (6) that is sent back to the computer when command 2 and sub-commands 3 and 4 are executed may appear to be a waste of time. However, this is the only way to test for proper communication between the computer and controller. It is not necessary to input the ACK code after execution of these commands.

If the ACK code is not input, you must generate some amount of delay to allow it time to send the ACK code and get ready to receive the next byte. It cannot receive and transmit data simultaneously as your computer can! Maximum reliable operating speed can be obtained by inputting the ACK code before sending the next output command byte to the controller.

The following decimal values shown in parentheses can be used as the output command byte instead of using the above sample statement for

the sub-commands: SC1 = (3), SC2 = (7), SC3 = (11), SC4 = (15), SC5 = (19), SC6 = (23), SC7 = (27) and SC8 = (31). If two controller cards are used to expand the I/O capabilities of the project, the decimal value 128 must be added to this value if the sub-command is intended for the controller that has the OPTION jumper installed in it.

### Test Fixture

The test fixture mentioned at the beginning of this article is shown in Fig. 6 plugged into P1 and P2 on the controller board. Schematic details of the circuitry for the test fixture are shown in Fig. 7. References to P1 and P2 in Fig. 5 indicate where the various connections are to be made to the analog input and digital output lines on the controller circuit-board assembly via the DB-25 connectors.

Power for the analog and digital inputs of the test fixture is obtained from the same 9-volt dc source used for powering the controller circuitry. Voltage regulator VRI reduces the incoming 9 volts to the required 5 volts dc. **Caution:** Never apply a potential that is greater than 5 volts dc to any analog or digital input line in the controller. Otherwise, one or more solid-state devices in the project is almost certain to result.

You can assemble this circuit on a rigid 1/8-inch thick plastic panel or 16-gauge metal panel, using all-new components or components you may already have on hand. Switches S1

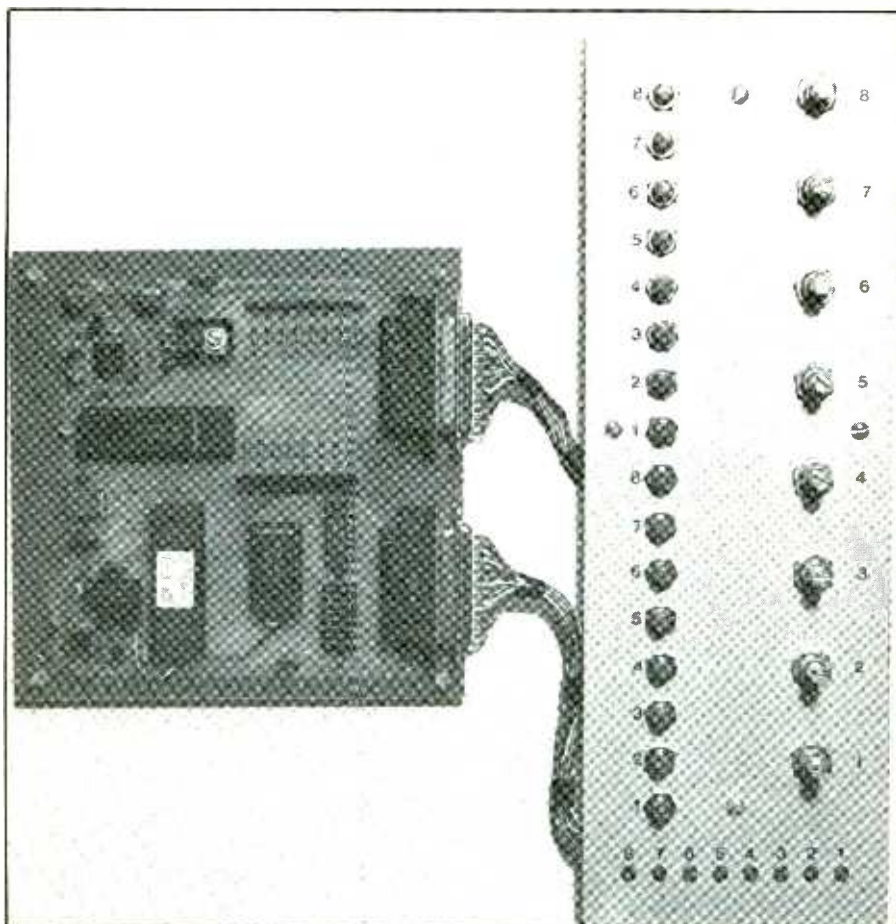

Fig. 6. Wired project and test fixture shown connected together. Not shown is three-conductor serial-in, serial-out and ground cable that goes to computer.

through *S16* are ordinary normally-open, momentary spst pushbutton types. Use any type of visible light-emitting diodes for *D1* through *D8*. Also, almost any type of panel-mount potentiometers can be used for *R17* through *R24*. Resistance values are not critical to circuit performance, but it is recommended that you limit value selections to the range from 1,000 to 50,000 ohms.

As you can see in Fig. 7, the circuitry for the test fixture is simple and straightforward. No circuit board—printed-circuit or otherwise—is needed to wire together the circuit. In fact, you mount all components either directly on the metal or plastic panel or, as in the case of resistors *R1* through *R8* and the cathode connections of light-emitting diodes *D1*

through *D8*, via suitable terminal strips secured to the panel. Use terminal strips that have no lugs electrically connected to their mounting tabs.

Machine the plastic or metal panel as needed. That is, drill the mounting holes for the pots, switches and LEDs, making the latter just large enough to accommodate the LEDs with a bit of pressure. Also, drill holes for mounting any terminal strips you will be using and the voltage regulator and four holes with which to mount the assembly.

After machining a metal panel, deburr all holes to remove sharp, ragged edges. Scrub the panel to remove dirt, grease and grime and thoroughly dry it. Then use a dry-transfer lettering kit or a tape labeler to label each switch, LED and control hole as

shown. If you use dry-transfer lettering, protect it from abrasion with two or more light coats of clear acrylic spray. Allow each coat to dry before spraying on the next.

When the panel is ready, mount the pots, switches and LEDs in their respective holes and the terminal strips near the LEDs. Use the hardware supplied with the switches and pots to mount these components. If any LEDs do not remain in place by friction fit, use a small daub of fast-setting epoxy cement on each.

If you use a plastic panel, place a small heat sink between it and *VRI*. If the panel is metal, the panel itself will be the heat sink, but use heat-transfer paste and an insulator between the case of the regulator and panel and appropriate insulating hardware to mount the regulator.

When all components have been physically mounted in place on the panel, wire them together exactly according to Fig. 7, using point-to-point wiring. Check off each lead and conductor run as you make it, and make certain that the LEDs and *CI* are properly polarized and that appropriate connections are made to voltage regulator *VRI*.

Start wiring the circuit with *R1* through *R8*, connecting one end of each of these resistors to its own separate terminal-strip lug. Do not solder any of these connections just yet. Terminate the free leads of all eight resistors in a single terminal-strip lug. Also crimp one end of an appropriate length of hookup wire at this lug (do not solder the connection yet). If a single lug will not accommodate all these leads, the wire and one more wire, use two lugs, bridging them with a length of wire.

Slip a 1-inch length of small-diameter heat-shrinkable tubing onto the free end of the wire connected to the common lug of *R1* through *R8*. Crimp and solder the wire to the INPUT (+9V) lead of *VRI*. Slide the tubing over the connection and shrink it into place.



# New! NRI course in Cellular Telephone Installation and Servicing prepares you to succeed in today's fastest-growing communications field

Now you can get the skills you need to cash in on today's booming cellular industry as you install and test your own state-of-the-art cellular telephone.

Cellular business is big business!

In the few short years since the first commercial cellular telephone system went on-line, over 1,000,000 people have signed up for service in more than 120 cities nationwide. Today, the industry is growing at an incredibly fast 4% a month, and experts predict that by 1991, at least 85% of the United States will be covered for cellular service. Better yet, by 1993 total industry revenues will exceed \$10,000,000,000—making cellular the fastest growing electronics communications field today.

For you, that means extraordinary career and money-making opportunities. Get a fast start today with NRI's hot new course in Cellular Telephone Installation and Servicing. See how far you can go!

## Help wanted! Urgent demand for field technicians who can install and test new cellular telephone equipment!

Get the skills, knowledge, and confidence to install and test cellular telephone equipment, and you can name your price in this exploding new job market. Cellular system developers, retailers, and service providers—all on the ground floor of an industry that's still so young and growing so fast—are all willing to pay a premium for anyone trained to service this brand-new equipment.

Now, with NRI, you can take full advantage of every exciting opportunity in today's—and tomorrow's—booming field of cellular communications.

## Exclusive hands-on training includes high-performance mobile cellular telephone you keep

Your NRI course starts with the electronics fundamentals you need to understand and service all telephone systems, then walks you step by step through the installation, troubleshooting, and repair of popular telephone systems in use today.

But that's just the beginning. With a solid conventional phone servicing foundation behind you, you're ready to build your expert understanding of the cellular telephone systems moving fast into communities all over the U.S.

Following complete, easy-to-read guidelines, you install a full-featured mobile cellular telephone in your own car, then take it through a series of diagnostic tests to become fully acquainted with its operating functions. Best of all, if you live in an area already offering

Includes full-featured mobile cellular telephone you keep!



10-digit luminescent display with 24-digit number entry/review

Ignition sense automatically turns your phone on and off with car's ignition

Electronic lock prevents unauthorized use of your phone

22 memories including last number called

Super speed dialing and 1 digit recall

cellular coverage, NRI will help you actually go on-line with up-to-date, expert advice on choosing the best and most affordable cellular service available.

## Send for your FREE catalog today

For all the details about NRI's exclusive new training, send the coupon today. You'll receive a complete catalog describing NRI's Cellular Telephone Installation and Servicing course plus NRI courses in other high-tech, in-demand fields.

If the coupon is missing, write to NRI School of Electronics, McGraw-Hill Continuing Education Center, 4401 Connecticut Avenue, Washington, DC 20008.

### Send Coupon Today For Free Catalog!

**NRI** School of Electronics

McGraw-Hill Continuing Education Center  
4401 Connecticut Ave, Washington, DC 20008



For career courses approved under GI Bill  
 check for details.

CHECK ONE CATALOG ONLY

- |  |   |
|--|---|
| <input type="checkbox"/> Cellular Telephone          | <input type="checkbox"/> Data Communications  |
| <input type="checkbox"/> Computer Electronics        | <input type="checkbox"/> Security Electronics |
| <input type="checkbox"/> TV/Video/Audio Servicing    | <input type="checkbox"/> Robotics             |
| <input type="checkbox"/> Electronic Music Technology | <input type="checkbox"/> Basic Electronics    |

Name \_\_\_\_\_ Age \_\_\_\_\_

Street \_\_\_\_\_

City/State/Zip \_\_\_\_\_

Accredited Member National Home Study Council

7-079

Interconnect one lug of *S1* through *S8* with a continuous length of bare hookup wire, terminating the end of this wire in a chassis grounding lug. Solder the connections at all switch lugs but not at the grounding lug. Do the same for one lug of *S9* through *S16*, and repeat with one lug of the potentiometers (use lug 3, the one on the right when viewing the pots from the rear, for this run). Crimp the negative (-) lead of *C1* to the lug. Again, do not solder the connection in both cases.

Crimp but do not solder one end of an appropriate-length hookup wire to the grounding lug. Slip a 1-inch length of heat-shrinkable tubing over the free end of this wire and crimp and solder the wire to the OUTPUT (+5V) lead of the voltage regulator. Slide the tubing over the connection and shrink into place.

Crimp and solder one lead of *R9* through *R16* to lug 1 of the potentiometers as shown in Fig. 7. Lengthen the other leads of the resistors as follows. First trim these leads to 1/2 inch in length and form a small hook in the stub. Crimp and solder appropriate-length hookup wires to the stubs. Slip a 1-inch length of heat-shrinkable tubing over the free ends of the wires. Slide the tubing over the connections to completely cover them and shrink into place. Crimp but do not solder the free ends of these wires to the unoccupied lugs of switches *S9* through *S16*.

Clip the cathode lead of each LED to a length of 1/2 inch and form a small hook in the remaining stubs. Crimp and solder one end of appropriate-length hookup wires to the stubs. Slip a 1-inch length of heat-shrinkable tubing over the free end of each wire. Slide the tubing up over the soldered connections and flush against the bottom of the LED cases and shrink into place.

Crimp and tack-solder the free ends of the cathode wires to separate terminal-strip lugs. Then repeat the entire operation for the anode leads

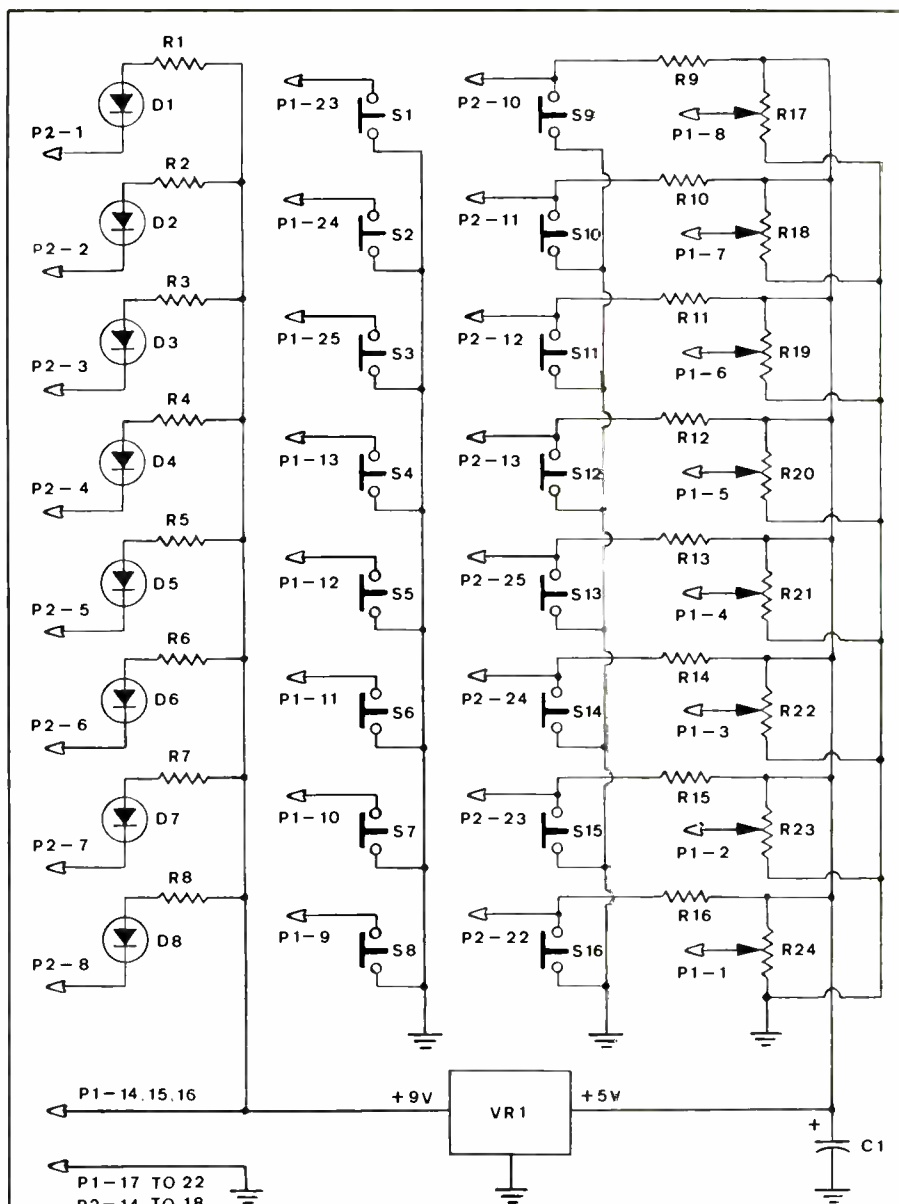

#### PARTS LIST (Test Fixture)

##### Semiconductors

D1 thru D8—Light-emitting diode  
VR1—7805 +5-volt fixed regulator

##### Capacitors

C1—10- $\mu$ F, 15-volt electrolytic

##### Resistors (1/4-watt, 10% tolerance)

R1 thru R8—470 ohms  
R9 thru R16—10,000 ohms  
R17 thru R24—1,000-ohm to 50,000-ohm panel-mount potentiometer (see text)

##### Miscellaneous

S1 thru S16—Momentary-action push-button switch (see text)  
Two DB-25P connectors; connector to match serial I/O connector on computer (see text); terminal strips (see text); grounding chassis lug; rigid plastic or metal sheet (see text); small-diameter heat-shrinkable tubing; 1/2-inch spacers; machine hardware; stranded hookup wire; solder; etc.

Fig. 7. Schematic diagram of test-fixture circuitry.



of the LEDs, this time terminating the free ends of the wires at the terminal strip lugs to which *R1* through *R8* are connected.

You need two short 25-conductor cables, each terminated at one end in a DB-25 connector to mate with *P1* and *P2* on the controller circuit-board assembly. You also need another cable with three conductors and terminated in a DB-25 connector that plugs into the serial I/O connector on your computer. You can make these cables using stranded hookup wire and appropriate connectors.

When making the cables, strip  $\frac{1}{4}$  inch of insulation from only one end of each wire. Tightly twist together the fine conductors that are exposed and sparingly tin with solder. You need 35 wires that are 30 inches in length and three wires that are 36 inches in length. Prepare both ends of the latter three wires as described.

For the following steps, use the 30-inch-long wires. Crimp and solder the prepared end of eight wires to the lugs to which the cathodes of the LEDs are connected. Similarly, crimp and solder the prepared end of eight more wires to the unoccupied lugs of *S1* through *S8*, another eight wires to the lugs of *S9* through *S16* to which *R9* through *R16* are connected, and yet another eight wires to the center lugs of the potentiometers.

Now crimp the prepared ends of the three remaining wires to the lugs to which all eight leads of *R1* through *R8* are connected and solder the connection. Then crimp and solder the prepared end of the remaining two 30-inch-long wires to the chassis grounding lug.

After making all connections, neatly bundle together the wires for *P1* and use plastic cable ties, waxed lacing cord or electrical tape to secure the bundle, ending about 6 inches from the unprepared end. Do the same for the wires for *P2*. Trim the wires in both bundles all to the same length, leaving at least 3 inches of un-

bundled length in both cases.

Strip  $\frac{1}{8}$  inch of insulation from the end of each wire in both bundles. Tightly twist together the exposed conductors and sparingly tin with solder. Use heat judiciously to minimize damage to the insulation.

Use your soldering iron to carefully heat the pin cups on both DB-25 connectors that will mate with *P1* and *P2* on the controller board and flow a small amount of solder into each. Make sure you get solder into only the cups and do not create solder bridges between the closely-spaced cups. To terminate each wire from the cables, simply heat the cup and plug into it the free end of the wire, remove the heat and allow to cool undisturbed.

Begin wiring the connectors by tack-soldering lengths of bare hookup wire to the pins 14, 15 and 16 posts and the pins 17 through 22 posts of the connector that will plug into *P1*. Position these wires near where the posts enter the plastic form that holds them in place on the DB-25 connector that will plug into *P1* on the controller board. Do the same for the pins 14 through 18 posts for the connector that will plug into *P2* on the controller board.

Retrieve the three 36-inch-long wires you prepared. Connect one end of these wires to pins 17, 18 and 19 of the *P2* connector. Use electrical tape to secure these three wires together in a neat bundle along their entire length to within 3 inches of the free ends. Using the same procedure detailed above, terminate the free ends in a DB-25 or other connector that mates with the serial I/O connector on your computer. Terminate each wire at the appropriate serial data in, serial data out and ground connector pin for your computer. Use an ohmmeter or audible signal tracer to identify which wire goes to which pin in all cases.

Solder the ends of the cables to their respective connector pin cups. Again, make sure you do not create

unwanted solder bridges between the closely-spaced cups. Also, make sure that each connection is electrically and mechanically secure. When you are finished, mount the test-fixture assembly on a metal or plastic plate, using  $1\frac{1}{2}$ -inch spacers and suitable-length machine screws, nuts and lockwashers.

---

### *Using the Test Fixture*

---

After you double-check your work on the test fixture and are satisfied that it is correctly wired, plug the DB-25 connectors at the ends of its cable into their respective connectors on the controller board and the serial I/O connector on your computer. Plug the 9-volt dc power supply into its jack on the project and turn on both computer and controller.

Boot up your computer and load into memory the BASIC language interpreter. Then key into the computer the program listing given elsewhere in this article. Save the program to disk and then recall and RUN it. As the program runs, it will display on the video monitor screen of the computer three vertical columns of video inputs. The column on the left displays analog inputs 1 through 8. These are fed in as digital inputs using sub-command 5 and are displayed as 0s and 1s. The decimal value of all eight inputs combined is displayed just below this column.

If normally-open switches are used for *S1* through *S8* in the test fixture, all 1s will be displayed on-screen in the column on the left. Pressing any of these switches to close its contacts causes the position in the column for that input to become a 0.

The middle on-screen column displays analog inputs 9 through 16. These are input using command 1. Each input is displayed as a decimal value that is between 0 and 255, corresponding to the input potential of from 0 to 5 volts. You can change the values displayed for these inputs by varying the settings of the potentiometer.

**ORDER FROM JAN FOR CRYSTAL CLEAR COMMUNICATION**



- YOUR RELIABLE SOURCE SINCE 1965
- QUICK DELIVERY
- PRICED RIGHT
- EMERGENCY ORDER SERVICE AVAILABLE

FOR FREE CATALOG, CALL OR WRITE:

**JAN CRYSTALS**

P.O. BOX 06017

FORT MYERS, FL 33906



(813) 936-2397



**TOLL-FREE: 1-800-237-3063**

IN FLORIDA: 1-800-226-XTAL  
FAX ORDERS: 1-813-936-3750

CIRCLE 25 ON FREE INFORMATION CARD

**LEARN VCR CLEANING/MAINTENANCE/REPAIR**  
EARN UP TO \$1000 A WEEK, WORKING PART TIME FROM YOUR OWN HOME!



Secrets Revealed!

NO Special Tools or Equipment Needed.

**EARN UP TO \$60 AN HOUR AND MORE!**

**THE MONEY MAKING OPPORTUNITY OF THE 1990'S**

IF you are able to work with common small hand tools, and are familiar with basic electronics (i.e. able to use voltmeter, understand DC electronics) . . . .

IF you possess average mechanical ability, and have a VCR on which to practice and learn . . . then we can teach YOU VCR maintenance and repair!

FACT: up to 90% of ALL VCR malfunctions are due to simple MECHANICAL or ELECTRO-MECHANICAL breakdowns!

FACT: over 77 million VCRs in use today nationwide! Average VCR needs service or repair every 12 to 18 months!

Viejo's 400 PAGE TRAINING MANUAL (over 500 photos and illustrations) and AWARD-WINNING VIDEO TRAINING TAPE reveals the SECRETS of VCR maintenance and repair— "real-world" information that is NOT available elsewhere!

Also includes all the info you'll need regarding the BUSINESS-SIDE of running a successful service operation!

FREE INFORMATION  
CALL TOLL-FREE 1-800-537-0589

Or write to:

Viejo Publications  
3540 Wilshire BL. STE 310  
Los Angeles, CA 90010 Dept ME

CIRCLE 44 ON FREE INFORMATION CARD

**Test Fixture BASIC Program Listing**

```

100 CLS: PLC=0: OPEN"COM1:1200,N,8,1" AS #1
200 PRINT#1,CHR$(19);: I=ASC(INPUT$(1,#1))
300 LOCATE 16,14: PRINT I," ";
400 COL=15: ROW=7: GOSUB 2700
500 PRINT#1,CHR$(7);: I=ASC(INPUT$(1,#1))
600 LOCATE 16,46: PRINT I," ";
700 TI=I: COL=47: ROW=7: GOSUB 2700
800 CN=1: ROW=14: COL=30
900 FOR CH=9 TO 16
1000 PRINT#1,CHR$(((CH-1)*4)+CN);: I=ASC(INPUT$(1,#1))
1100 LOCATE ROW,COL: PRINT I," ";
1200 ROW=ROW-1: NEXT CH
1300 PLC=PLC+1: IF PLC=256 THEN PLC=0
1400 PRINT#1,CHR$(11);: I=ASC(INPUT$(1,#1))
1500 PRINT#1,CHR$(PLC);: I=ASC(INPUT$(1,#1))
1600 LOCATE 16,30: PRINT PLC," ";
1700 IF TI (<) 126 THEN GOTO 200
1800 PRINT#1,CHR$(11);: I=ASC(INPUT$(1,#1))
1900 PRINT#1,CHR$(0);: I=ASC(INPUT$(1,#1))
2000 FOR T = 1 TO 1000: NEXT T
2100 CN=2: FOR OS = 1 TO 0 STEP -1
2200 FOR CH = 1 TO 8
2300 PRINT#1,CHR$((OS*64)+((CH-1)*4)+CN);
2400 FOR T = 1 TO 200: NEXT T
2500 I=ASC(INPUT$(1,#1)): NEXT CH: NEXT OS
2600 GOTO 200
2700 BV=128: FOR BIT=1 TO 8
2800 IF (I-BV)=0 THEN GOSUB 3300 ELSE GOSUB 3400
2900 NEXT BIT
3000 FOR X=1 TO 8
3100 LOCATE ROW,COL: PRINT SW(X);
3200 ROW=ROW+1: NEXT X: RETURN
3300 SW(BIT)=1: I=I-BV: BV=BV/2: RETURN
3400 SW(BIT)=0: BV=BV/2: RETURN

```

meters on the test fixture. The decimal value displayed below the middle column is the program loop counter and increments one step each time the main program loops back to the beginning.

The program loop count value is also output to digital I/O lines 1 through 8, using sub-command 3. The loop count is displayed in binary by the eight LEDs that are controlled by these lines in the test fixture.

The right column displays digital I/O lines 9 through 16 and are input using sub-command 2. Switches S9 through S16 on the test fixture correspond to this column. Their conditions are displayed in the same manner as described for the left column.

Analysis of the test program is as follows:

- Line 100 clears the screen, sets the program loop counter to 0 and opens COM1 for communication at 1,200 baud with no parity, eight data bits and one stop bit.
- Line 200 outputs sub-command 5 and then pauses for the input character from the controller.
- Line 300 prints the received input character.
- Line 400 sets up the screen display location variables and then executes a subroutine at line 2700 that displays each individual bit of the eight-bit input character as a 0 or a 1 on the screen in a vertical column.
- Lines 500, 600 and 700 are identical



to lines 200, 300 and 400, except that sub-command 2 is used and the inputs are displayed in the right column on the screen. This input character is also saved as variable "TI" to be tested later in the program.

- Line 800 sets the command to 1 and sets up screen location variables before executing lines 900 through 1200, which inputs and displays analog inputs 9 through 16 in the center column on the screen.

- Line 1300 increments the program loop counter.

- Lines 1400 and 1500 use sub-command 3 to output the program loop count to digital I/O lines 1 through 8.

- Line 1600 prints the program loop count below the middle column on the screen.

- Line 1700 tests variable "TI," which is the saved value of digital I/O lines 9 through 16. If switches *S9* and *S16* on the test fixture are pressed and held closed simultaneously (these switches are normally open), the routine at line 1800 will begin executing.

- Lines 1800 through 2700 make up a subroutine that clears digital I/O lines 1 through 8 with sub-command 3 and then uses sub-command 2 to sequence these lines on and then off.

## Hardware Interfacing

You can use the test fixture whose circuitry is shown in Fig. 7 as a simple guide when interfacing the controller to your unique applications. For example, you can replace *S1* through *S16* with the contacts of relays or magnetic reed switches. Potentiometers *R17* through *R24* could be replaced with simple resistance voltage-divider networks for monitoring potentials that do not exceed 5 volts dc. (Remember the warning against applying potentials greater than 5 volts dc to the analog or digital lines!)

You can use a thermistor as one of the resistive elements in any voltage-divider network to monitor tempera-

ture. Alternatively, a photocell can be used in any network to detect changes in light levels.

A small relay coil or solid-state switch module can be substituted for light-emitting diode *DI* and current-limiting resistor *R1*. Solid-state switch modules typically isolate the input from the load for protection and can be obtained for both ac and dc switching applications.

As you experiment with this project, you will undoubtedly come up with other interfaces to suit particular applications. There is no limit to what you can do with this project, depending on your imagination and technical expertise.

Although this project was designed primarily for use with IBM PC/XT/AT and compatible computers, the controller circuit-board assembly can be used with any computer that has an RS-232 serial interface. To this end, the project was originally conceived for use on a Radio Shack TRS-80 Model I-compatible system.

On other popular home computers, a major obstacle that might be encountered is that the BASIC programming language structure might permit a string to be only input from a serial port. From the foregoing, it should be obvious that your system must be able to input and output one character at a time via the serial port for the project to operate properly. The character must also be eight bits in length.

For computers that have the above limitation, a machine-language call can be used to perform the serial input/output function. For the TRS-80 Model I, a short machine-language user call can be used to output the command byte first and then pause for the serial input character before returning to BASIC. If no character is received within a specified period of time, on the order of milliseconds, the routine would return with a value that is greater than a decimal 255, indicating that a communication failure has occurred. **ME**

Put Professional Knowledge and a  
**COLLEGE DEGREE**  
in your Technical Career through

**HOME  
STUDY**

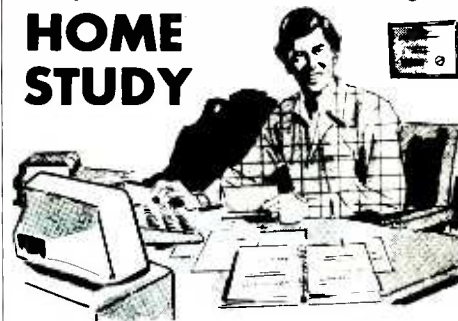

Add prestige and earning power to your technical career by earning your Associate or Bachelor degree through directed home study.

Grantham College of Engineering awards accredited degrees in  
**electronics and computers.**

An important part of being prepared to *move up* is holding the right college degree, and the absolutely necessary part is knowing your field. Grantham can help you both ways—to learn more and to earn your degree in the process.

Grantham offers two degree programs—one with major emphasis in **electronics**, the other with major emphasis in **computers**. Associate and bachelor degrees are awarded in each program, and both programs are available completely by correspondence.

No commuting to class. Study at your own pace, while continuing on your present job. Learn from easy-to-understand lessons, with help from your Grantham instructors when you need it.

*Write for our free catalog* (see address below) or telephone us at (213) 493-4421 (no collect calls) and ask for our "degree catalog."

Accredited by  
the Accrediting Commission of the  
National Home Study Council

**GRANTHAM**  
**College of Engineering**  
10570 Humbolt Street  
Los Alamitos, CA 90720

# Pulse Circuits Revisited

## Generating pulses and waveforms from experimental circuits

By Joseph J. Carr

In February, we discussed how pulses and other non-sinusoidal waveforms are composed of a series of harmonically-related sine and cosine waves. Only the pure, undistorted sine wave contains only a single frequency, which we call the "fundamental." All other waveforms have a fundamental—which sets the frequency of the waveform or pulse repetition rate of the pulse train—and a collection of harmonics.

Our objective this month is to look at ways to generate pulses and waveforms using your own experimental circuits. We will consider methods for creating single pulses, pulse trains and square waves using the popular 555 integrated circuit timer, TTL devices and CMOS devices.

### Classes of Circuits

In this installment, we will look at two classes of circuits that will accomplish our aims. One is monostable multivibrators, commonly referred to as "one-shot" oscillators. The other is the astable multivibrator.

The monostable multivibrator gets its name from the fact that it has only one stable state. The circuit remains dormant in this state until it is triggered, as illustrated in Fig. 1. When a trigger pulse is received, the monostable multivibrator snaps to an unstable output state, where it remains for a predetermined period of time called "T." When time T expires, the circuit reverts back to its stable or so-called "dormant" state.

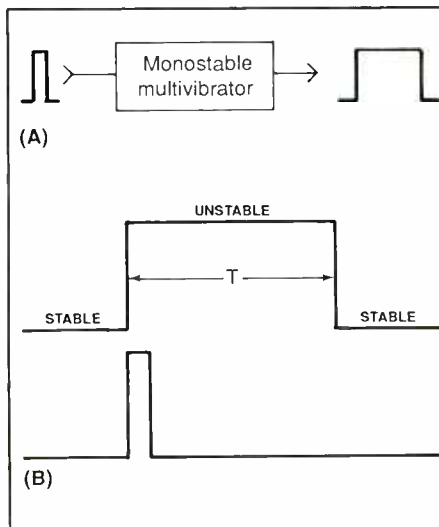

Fig. 1. When trigger pulse is received, output of monostable multivibrator circuit (A) must "time out" before it can respond to another triggering pulse; only two states (B) are possible.

Monostable multivibrator circuits can be further subdivided into "retriggerable" and "non-retriggerable" categories. The difference between these two types of circuits is in whether or not the circuit will accept a trigger pulse prior to expiration of the duration of the pulse.

Shown in Fig. 2(A) is the non-retriggerable response. At time  $T_1$ , a trigger pulse is received and the output snaps to a logic high for time T. At time  $T_2$ , however, a second trigger pulse is received. The circuit ignores this second trigger pulse because it is already active. At time  $T_3$ , the original pulse "times out," which readies the circuit to receive and act upon another trigger pulse. The sub-

sequent trigger at time  $T_4$  reactivates the output to a logic high.

All non-retriggerable monostable multivibrators (which means most such circuits) ignore the trigger input until the time-out period has elapsed. Some circuits will also ignore new trigger pulses until after a post-time-out "refractory period" expires. This period is short and not of significance in modern circuits. However, it was quite significant in the days before integrated circuits.

The usefulness of the non-retriggerable multivibrator is seen in applications like switch and relay contact debouncing circuits. The "bounce" of switch and relay contacts has the effect of applying to the input of a circuit multiple pulses rather than the single one that should be received. By letting the first pulse "fire" a non-retriggerable one-shot multivibrator and making duration time T long enough for secondary "bounce" pulses to die out, a clean contact-closure signal is obtained.

Shown in Fig. 2(B) is the retriggerable monostable multivibrator response. The original trigger pulse occurs at time  $T_1$ , at which point the output snaps to logic high for the duration of time T. At time  $T_2$ , when a second pulse is received, the circuit "retriggers" for an additional time T. The total duration of the high output state, then, is  $T_4 - T_1$ , or natural duration time T plus a shorter duration  $T_2 - T_1$ .

Usefulness of the retriggerable multivibrator circuit is seen in alarm circuits. In medical electronics, for example, these circuits are frequently



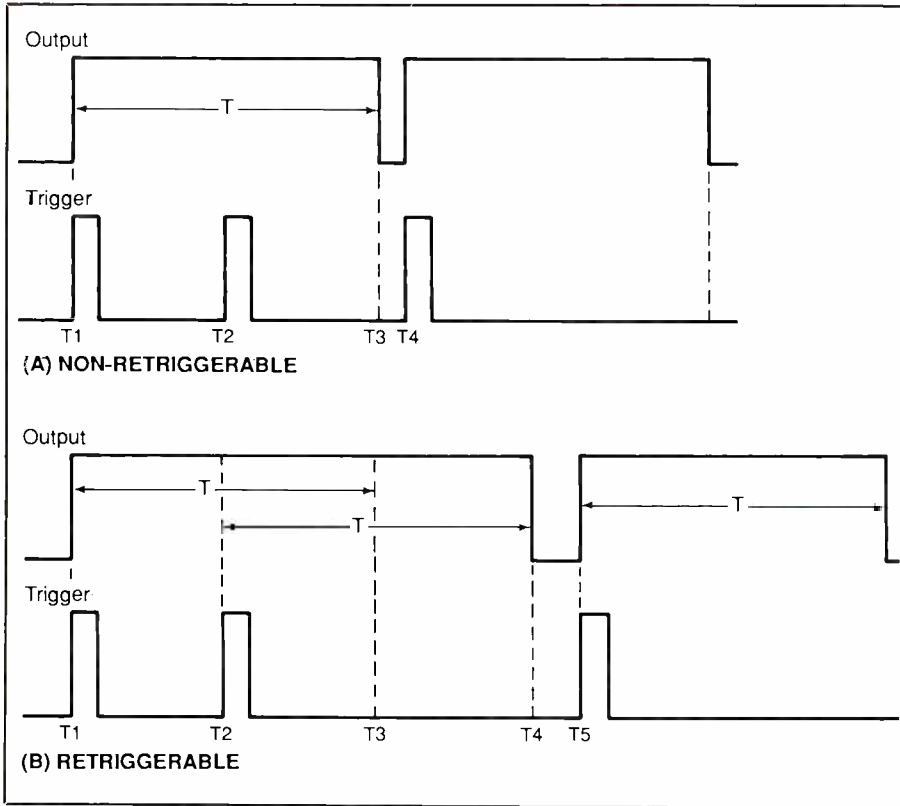

Fig. 2. Responses of non-retriggerable (A) and retriggerable (B) multivibrators.

used in respirator alarms. A signal from a transducer is wave-shaped into pulse form and applied to the trigger input of the retriggerable monostable multivibrator. Duration  $T$  is set to the limits that the doctor feels indicates that the patient has ceased breathing. If no "breath" signal re-triggers the one-shot multivibrator before the circuit times out, the output snaps to logic low and triggers the alarm.

A monostable multivibrator produces only one output pulse for every input trigger pulse. The output pulse of the circuit has a constant duration and amplitude even when the triggering pulse is ragged. Typical uses of the one-shot multivibrator include cleaning up of pulses after transmission (where path losses roll off frequencies and so distort the pulse), "stretching" short-duration pulses, debouncing switch and relay contact closure signals and actuating digital circuits.

An astable multivibrator has no stable states. Its output waveform bounces up and down, as illustrated in Fig. 3, between two possible unstable states. If the durations of the two unstable states are equal, the output from the astable multivibrator resembles the classical square waveform. If the high and low unstable states are unequal in duration, the output waveform resembles a digital pulse train.

### Actual Circuits

Monostable multivibrators can be built using TTL, CMOS and other integrated-circuit devices. The popular 555 timer is a particularly useful IC device. In Fig. 4 is shown the use of simple CMOS inverters or noninverting followers. These circuits can be built using such hex chips as the 4049 and 4050 or from NAND or NOR gates wired as inverters.

In Fig. 4(A) is shown the schematic

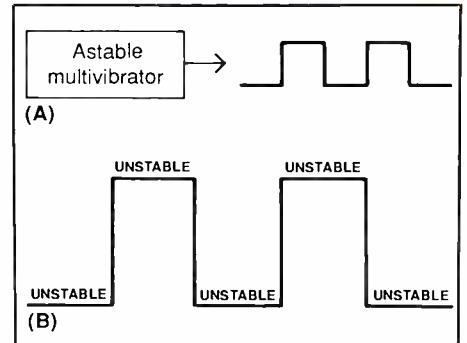

Fig. 3. Output from astable multivibrator (A) alternates between high and low logic states; both states (B) are unstable.

diagram of a positive-edge-triggered one-shot multivibrator circuit that can produce either positive- or negative-going output pulses. If you need only one direction of pulse, however, feel free to omit the other device.

The Fig. 4(A) circuit operates by nature of the fact that CMOS circuits change state when the input potential crosses a point midway between the positive and negative supply voltages. If only one supply is used, such as  $V+$  only, the transition point occurs at  $0.5V+$ .

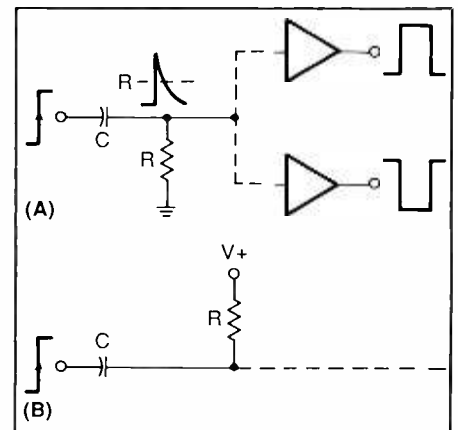

Fig. 4. Positive-edge-triggered one-shot multivibrator can produce positive- and negative-going output pulses (A) when bipolar power supply is used; with single-ended power supply reference end of resistor tied to  $V+$  (B), circuit can be made to respond to negative-going edge triggering.

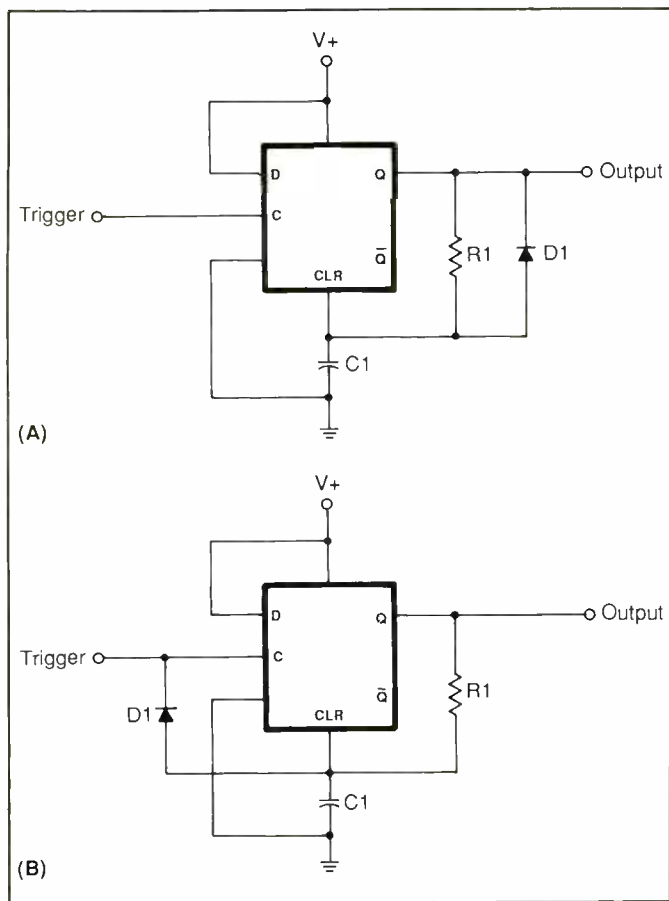

Fig. 5. Two versions of monostable multivibrator built around 4013 CMOS D-type flip-flop: (A) non-retriggerable and (B) retriggerable.

The RC network acts as a differentiator so that the square input step-function used as a trigger signal forms the decaying output signal shown. The output snaps to logic high as soon as the input signal crosses point "A" in a positive-going direction and remains high until the newly charged capacitor discharges back to point "A," which causes the output to snap back to logic low. The duration of the output pulse is approximately  $T = 0.7RC$ , with T expressed in seconds.

The same circuit shown in Fig. 4(A) becomes negative-edge triggered by lifting the "cold" or ground end of resistor R and connecting it to the V+ rail. A significant limitation of this version of the circuit is that the

input trigger must remain active—logic high in this case—for a period of time that is longer than the duration of the output pulse.

Two versions of the monostable multivibrator built around the 4013 D-type flip-flop are shown in Fig. 5. The rules of operation for the D-type flip-flop are as follows:

- (1) The level on the D input to the flip-flop is transferred to the Q output when clock input C is at logic high;
- (2) The not-Q output is the complement, or opposite, of the Q output (that is, is Q = high, not-Q = low);
- (3) A logic high applied to clear input CLR forces the Q output to low and the not-Q output to high.

The non-retriggerable multivibra-

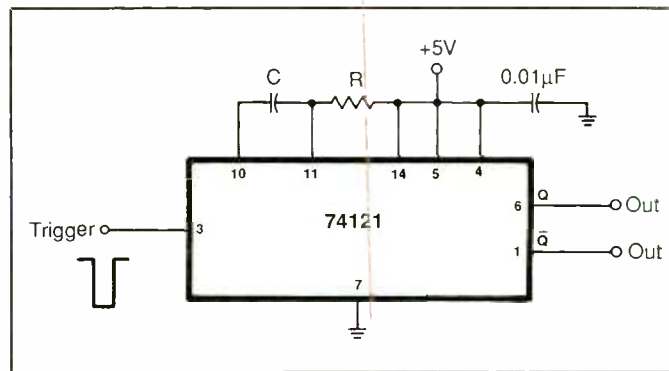

Fig. 6. One-shot multivibrator built around specialized 74121 TTL logic device.

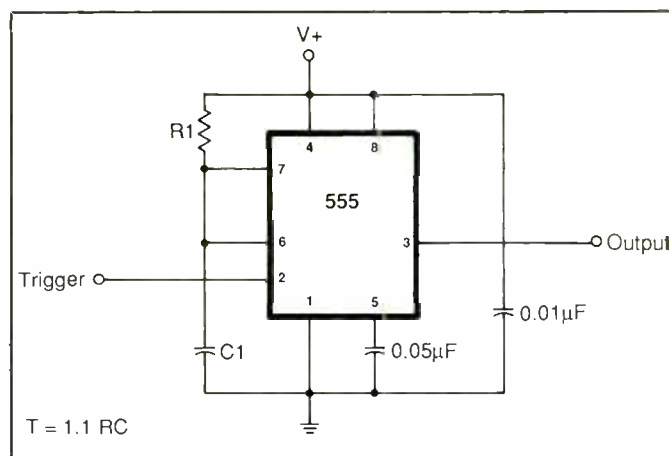

Fig. 7. Circuit for using 555 and 7555 IC timer chips as monostable multi-vibrators.

tor circuit shown schematically in Fig. 5(A) has its D input permanently tied to logic high by nature of it being connected to the V+ rail. When a trigger pulse forces clock input C high, the high on the D input is transferred to the Q output, making this output also high.

The high on the Q output causes capacitor C1 to begin charging at a rate determined by the value of resistor R1. When the potential across C1 reaches  $V+/2$ , the CLR input is activated, forcing the Q output low again. However, now diode D1 is forward-biased by the potential on the capacitor; so C1 rapidly discharges into the low Q output. Again,  $T = 0.7R1C1$ .

Shown in Fig. 5(B) is the retrigger-



able version of the Fig. 5(A) circuit. In this case, the discharge diode is connected from the CLR input of the D-type flip-flop to the trigger input. Retriggering occurs by bringing the trigger input to logic high and then back to logic low.

One-shot multivibrator circuits built using CMOS devices suffer from a couple of problems. Unless either specified B-series CMOS ICs or Schmitt-trigger CMOS devices are used, the rise and fall times of the output pulse will suffer. Also, very-short durations are difficult to achieve with most CMOS devices. In these cases, however, you may be able to turn to TTL devices.

TTL devices produce both shorter durations (in the nanosecond range) and faster rise times. You can use the same type of inverter-based one-shot multivibrator circuits in TTL as we discussed above for CMOS devices. Of course, you may prefer to opt for specialized multivibrator chips instead of TTL devices.

Shown in Fig. 6 is the schematic diagram of the specialized 74121 TTL-logic one-shot multivibrator. Also available are 74122 and 74123 TTL devices that can be used, though they operate in a slightly different manner to the 74121. Don Lancaster's *TTL Cookbook* gives the pin-outs and rules of operation for the other TTL one-shot multivibrators. When assembling the Fig. 6 circuit, use a value of greater than 10 picofarads for capacitor *C* and keep the value of resistor *R* between 2,000 and 40,000 ohms. Output duration of this circuit is approximately  $0.7RC$ .

TTL one-shot multivibrator devices are somewhat sensitive to electrical noise and, thus, are a little difficult to work with. Consequently, some experts recommend using either CMOS devices or a 555 timer unless you need very short durations.

In Fig. 7 is shown the schematic diagram of a circuit for using the 555 and 7555 timer chips as monostable multivibrator circuits. The circuit is

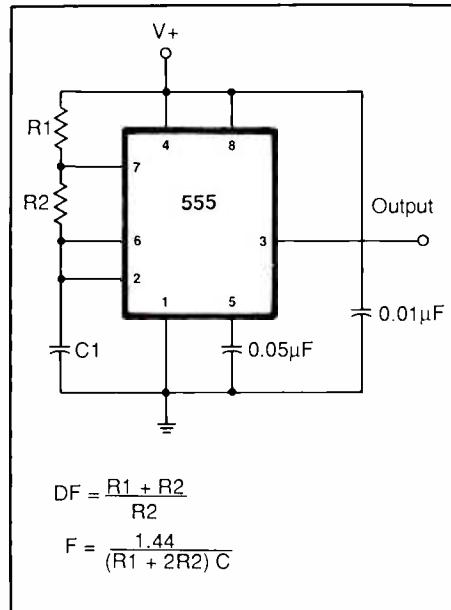

Fig. 8. Astable configuration for 555 and 7555 timer chip circuit.

timed by the values of *R1* and *C1*, and output duration is calculated using the formula  $T = 1.1R1C1$ . An advantage of this circuit is that it is compatible with TTL if *V+* is +5 volts. The circuit possesses a relatively high drive capability. It is also compatible with CMOS circuits that operate with a variety of solid-state and other components.

Shown in Fig. 8 is the astable configuration of the 555/7555 devices. In this case, the circuit is similar to a one-shot multivibrator that is self-triggered. The output frequency of

the circuit is calculated from the formula  $F = [1.44 / (R1 + 2R2)C1]$ . The duty factor (duty cycle) of the circuit is the ratio of high to low times and is calculated from the formula  $T = (R1 + R2) / R2$ .

### Pulse-Generator Circuit

A pulse-generator circuit must be able to develop an output train of pulses with variable duty factor. One of the easiest ways to obtain a wide-range pulse generator is to connect an astable multivibrator in cascade with a monostable multivibrator, as illustrated in Fig. 9. The RC network between the two stages is used to differentiate the astable output pulses.

By making the frequency of the astable circuit adjustable, you gain control over the pulse repetition rate. Similarly, pulse width is set by making the duration of the one-shot multivibrator stage adjustable. If desired, the output of the astable multivibrator stage can be brought out to a front-panel connector and used as a square-wave signal source.

### Summing Up

Pulse circuits are useful to both digital and analog circuit enthusiasts. Understanding the nature of pulses and pulse circuits goes a long way toward understanding much of electronics. This knowledge is useful to a wide range of amateur and professional electronics people alike. **ME**

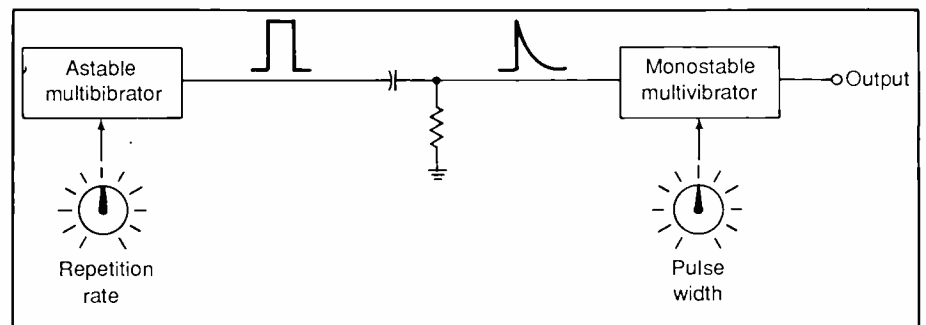

Fig. 9. Pulse generator circuit built using an astable multivibrator in cascade with monostable multivibrator.

# How To Use DC Voltmeters

*Some useful tricks of the trade for getting the most out of your dc voltmeter*

By Robert G. Middleton

A few months back, we discussed troubleshooting of the base-biased and emitter-biased common-emitter circuits (see "Troubleshooting With DC Voltmeters" *Modern Electronics*, October 1988). We are now ready to dig a bit deeper, this time into the basic collector-bias configuration. Our discussion here deals with circuit action and dc-voltage distribution patterns for localizing circuit faults, including collector-junction and coupling-capacitor leakages. As you will soon see, some circuit-action features may be a bit unexpected.

## Collector-Bias Circuit Action

Referring to Fig. 1, the elementary collector-bias configuration uses single bias resistor  $R_{b1}$ . Bias stability is reasonably good, since an increase in collector voltage is fed back to the base, where it produces an increase in emitter current that tends to reduce the collector voltage. Technically, collector bias circuit action involves voltage feedback, whereas base bias with emitter-bias circuit action involves current feedback. We will find some inconsistency in the literature regarding nomenclature. Therefore, here you will find it helpful to go along with tradition to designate collector-base feedback as voltage feedback and emitter feedback as current feedback.

Observe in Fig. 1 that the base bias voltage can be forced off-value by leakage in either coupling capacitor  $C_c$  or by leakage resistance from collector to base in the transistor. The

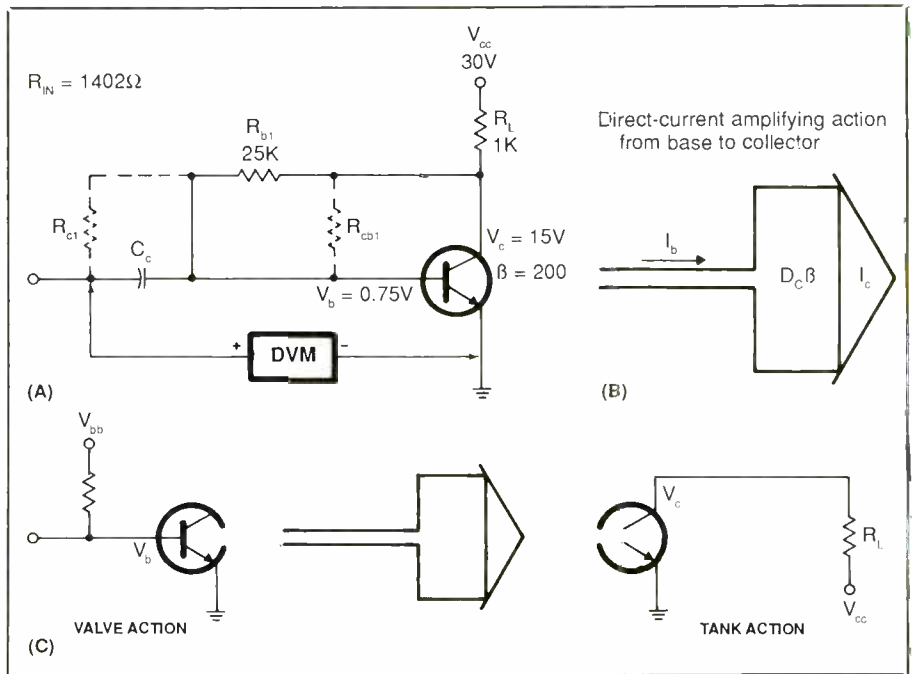

Fig. 1. Basic collector-bias circuit. Circuitry (A) with normal dc voltages; beta circuit action (B); and beta action taking place in collector branch (C).

primary symptom of leakage is decreased collector voltage.

To check for leakage in  $C_c$ , you monitor the base voltage while temporarily short-circuiting the left-hand end of  $C_c$  to ground. If the base voltage does not change, you conclude that  $C_c$  is not leaky and if base voltage changes, you can conclude that  $C_c$  is leaky and must be replaced.

To check for leakage from collector to base in the transistor, this particular circuitry requires a "last-resort" procedure. This is just another way of saying that troubleshooting procedures that do not require unsoldering of connections are required. In this case, you have no choice but to unsolder one end of  $R_{b1}$ . In turn, the

resistance of  $R_{b1}$  can be measured with an ohmmeter.

After one end of  $R_{b1}$  has been disconnected from the circuit, you can make a standard turn-off test to check for collector-base leakage. This is accomplished by temporarily short-circuiting the base and emitter terminals of the transistor as you monitor  $V_c$ . If  $V_c$  jumps up to the  $V_{cc}$  value, the collector junction is not leaky. If  $V_c$  falls short of the  $V_{cc}$  voltage, the transistor is leaky and must be replaced.

## DC Voltage Distribution Patterns

It is helpful now to consider the dc voltage distribution patterns for the



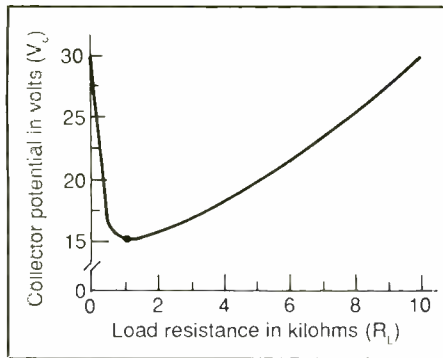

Fig. 2. Plot of variation in collector voltage versus load resistance.

Fig. 1 circuit configuration. You expect the patterns to change when a component drifts off-value. However, voltage-feedback circuitry can be a bit tricky in this regard. In this example, as the resistance of  $R_L$  varies from a very low value to a high value,  $V_C$  decreases to a minimum of 15 volts when  $R_L$  is 1,000 ohms, as illustrated in Fig. 2. Then, as the resistance of  $R_L$  increases further from 1,000 to 10,000 ohms,  $V_C$  no longer decreases. Instead, it increases steadily up to 30 volts when  $R_L$  is approximately 10,000 ohms.

Note that after  $V_C$  has increased to 30 volts, the collector cutoff level has been reached and no further increase will occur in  $V_C$ , regardless of an increase in the resistance of  $R_L$ . This fall-and-rise collector circuit action should be kept in mind when you troubleshoot voltage-feedback circuitry. Otherwise, you could jump to false conclusions by assuming that collector circuit action is a one-way trend when the value of  $R_L$  goes high or low. Note that off-values of  $R_L$  cannot drive the transistor into saturation. However, leakage resistance can reduce  $V_C$  to near-zero potential.

Now consider the voltage-distribution patterns for abnormal and sub-normal parameter values, as shown in Table 1. There is one unique pattern in this tabulation:  $V_C$  low/ $V_B$  high indicates that  $R_{B1}$  is low. Note that the combination of  $V_C$  high/ $V_B$

low can be caused by  $R_{B1}$  high or (sometimes)  $R_L$  high.

To make a tentative distinction between these possibilities, a trick of the trade will prove helpful. It involves an extension of the data shown in Table 1 and pursues the question of how low  $V_B$  has gone in a particular trouble situation. This is just another way of saying that when the value of  $R_{B1}$  or  $R_L$  is high,  $V_B$  goes low—but with a proviso.

Suppose that the normal  $V_C$  value is 15 volts and the normal  $V_B$  value is 0.75 volt, as in Fig. 1. If  $R_L$  is the culprit,  $V_B$  will go twice as low as in the case that  $R_{B1}$  is causing the problem.

A practical example at this point is illuminating. If you consider the circuit parameters in Fig. 1,  $V_B$  is normally 0.75 volt. If the value of  $R_L$  increases from 1,000 to 5,000 ohms,  $V_C$  will rise to 21.2 volts and  $V_B$  will decrease to 0.66 volt (a decrease of 0.09 volt from the normal of 0.75 volt).

If the value of  $R_{B1}$  increases from 25,000 to 40,000 ohms,  $V_C$  will rise to 21.5 volts and  $V_B$  will decrease to 0.71 volt (this time, a decrease of 0.04 volt). Accordingly, with all other things remaining the same, increased values of  $R_L$  push  $V_B$  down twice as much as do increased values of  $R_{B1}$  (in this example).

The essence of this trick of the trade is for you to keep in mind that the foregoing general idea is base-voltage decrements under trouble conditions. A trouble condition is generally "spotted" first as a substantial increase in  $V_C$ , such as an in-

crease from 15 volts to 20 volts or more, as in this example.

When this off-value condition is encountered, you ask how  $V_B$  is behaving. You know from experience (or the service data) that  $V_B$  normally rests at 0.75 volt. Then if you find that  $V_B$  has dropped in value by about 0.1 volt, you know that the value of  $R_L$  has probably gone high. On the other hand, if you find that  $V_B$  has dropped in value by about 0.05 volt, you conclude that the value of  $R_{B1}$  has gone high.

Now consider a low-beta fault condition. As detailed in Table 1, when beta goes low, both  $V_C$  and  $V_B$  go high. In this example, when the value of  $R_L$  goes low, both  $V_C$  and  $V_B$  go high. A similar trick of the trade is very helpful in this situation. As a rough rule of thumb,  $V_B$  will go twice as high if beta is the culprit.

As a practical example, if the value of  $R_L$  decreases from 1,000 to 150 ohms,  $V_C$  will rise to 20.1 volts and  $V_B$  will rise to 1.11 volts. However, if beta decreases from 200 to 20,  $V_C$  will rise to 21.8 volts and  $V_B$  will rise to 1.22 volts.

The bottom line is that, disregarding the integral part of the measured values, the decimal portion of the measurements went twice as high when beta decreased in value.

As in the above example, it is evident that the essence of this trick of the trade is for you to keep in mind a general idea of base-voltage increments under trouble conditions. The guidelines are the same in either case.

Table 1. Dc Voltage Distribution For Abnormal & Sub-Normal Circuit Parameters

	$R_{B1}$ High	$R_{B1}$ Low	$R_L$ High	$R_L$ Low	Beta Low
$V_C$	High	Low	High or Low	High	High
$V_B$	Low	High	Low	High	High

Note: In this example, normal  $V_C$  is 12 volts and normal  $V_B$  is 0.75 volts; a High  $V_C$  is greater than 15 volts; a Low  $V_C$  is less than 15 volts; a High  $V_B$  is less greater than 0.75 volt; a Low  $V_B$  is less than 0.75 volt. Except for normal  $V_C$  and  $V_B$  voltages, all voltages are measured values.

You are looking at base-voltage decrements in the first example, whereas you are looking at base voltage increments in the second example.

### Boundary-Limit Parameters

Practical troubleshooting situations often involve boundary-limit analysis. Hence, the transistor will be cut off wherein collector voltage will be at the  $V_{CC}$  level, or the transistor will be in saturation wherein collector voltage will be almost zero. Although the transistor will be cut off (in this configuration) when any parameter goes sufficiently off-value, saturation cannot even be approached when  $R_L$  goes off-value, as we saw in Fig. 2. However, saturation can occur in the case of coupling-capacitor or collector-base junction leakage.

In Fig. 1, if  $R_{b1}$  increases in value to 62,650 ohms,  $V_C$  will equal  $V_{CC}$  and  $V_B$  will be 0.65 volt. However, if  $R_{b1}$  decreases in value to 1,000 ohms,  $V_C$  will fall to 2.2 volts. Perhaps unexpectedly, if  $R_{b1}$  decreases in value to less than 1,000 ohms,  $V_C$  will not decrease; instead, it will proceed to increase.

When  $R_{b1}$  is 1,000 ohms,  $V_B$  is 0.73 volt. If  $R_L$  goes very low in value or becomes short-circuited,  $V_C$  goes to 30 volts and  $V_B$  goes to 1.68 volts. This excessive bias voltage is a clue to you that the collector load resistor is the culprit.

There is a joker to contend with here. The excessive bias voltage is a clue to the possible cause of the trouble, but it is not conclusive evidence that it is the culprit. In the event that beta goes extremely low—below unity— $V_C$  goes to the  $V_{CC}$  level and  $V_B$  goes to 1.68 volts.

If you suspect that  $V_C$  has slumped to an extremely low value, you can opt to make an in-circuit resistance measurement of  $R_L$  with power to the circuit turned off, using a low-power ohmmeter. A low-power ohmmeter is required to avoid turning on a transistor junction and thereby falsifying the resistance measurement being made.

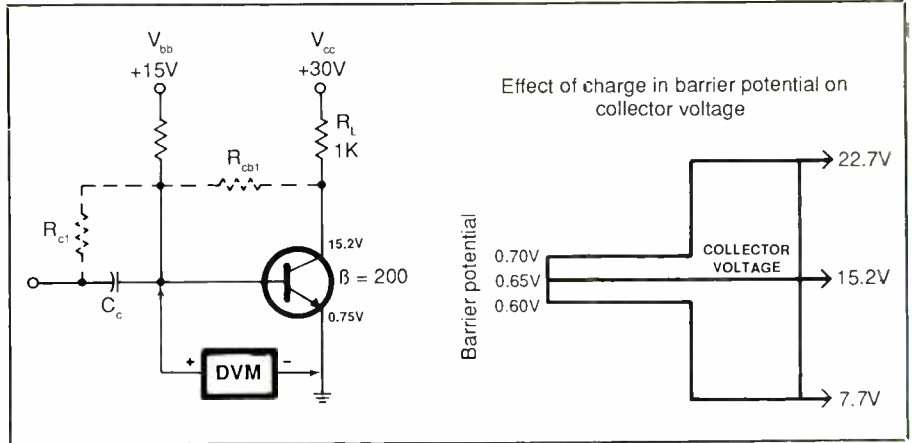

Fig. 3. Basic base-bias circuit without current or voltage feedback.

sifying the resistance measurement being made.

### Base Bias, No Feedback

It is helpful to briefly consider a very simple common-emitter circuit that employs base bias without either current or voltage feedback, as illustrated in Fig. 3. This "skeleton" arrangement illustrates the basic factors that are the foundation of circuit action in comparatively elaborate feedback networks. In practice, this elementary arrangement is rarely encountered, due to its relatively poor bias stability, susceptibility to "thermal runaway," and greater distortion level. The sole technical advantage of this simple arrangement is its relatively high gain.

As might be anticipated, the Fig. 3 circuit has low tolerance to variations in parameter values. For example, if  $R_{b1}$  increases in value from 26,700 to 28,000 ohms,  $V_C$  rises from 15.2 to 20.2 volts. This is a tolerance of less than 5 percent on the rated value of resistor  $R_{b1}$ .

"Thermal runaway" is the technical term for the rapid increase in dc beta that occurs when a transistor starts to heat up appreciably when it is overdriven. In the absence of negative feedback, the beta value "mushrooms" and excessive current flow damages or destroys the transistor.

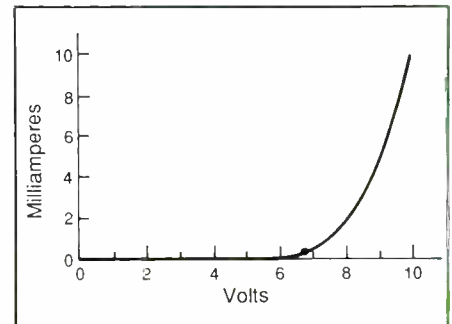

Fig. 4. A typical base-emitter junction characteristic in graphed form.

The 0.75-volt base potential of the Fig. 3 circuit results from voltage-divider action between  $V_{BB}$  and ground. Resistor  $R_{b1}$  has a rated value of 26,500 ohms in this example, and rated base potential is 0.75 volt. Thus, effective base input resistance is 1,405 ohms.

In Fig. 4, base input resistance is the ratio of  $V_B/I_B$  at the operating point on the base-emitter E/I junction characteristic. The bottom line is that Ohm's law calls the shots.

In this example, the transistor has a rated input resistance of approximately 1,500 ohms. However, measured values correspond to an input resistance of 1,405 ohms. There are two reasons for this discrepancy. One is that the rated input resistance of the transistor is specified on the basis of a short-circuited output. In practice, though, the output is not



short circuited but (in this example) the collector output is returned to ground via the 1,000-ohm load resistor. As will be demonstrated, base input resistance is a function of collector load resistance.

We will also show that base resistance is a function of the transistor's dc beta value. In Fig. 5, it is helpful to observe the traditional resistive ( $r$ ) parameter symbol and to disregard the modern symbol for a moment. When an input (bias) voltage is applied between the base and emitter terminals, base current  $I_b$  flows. Also, since the base circuit functions as a valve, collector current  $I_c$  also flows. This collector current is equal to base current  $I_b$  multiplied by the dc beta of the transistor, which is 200 in this example. In turn, total emitter current  $I_e$ , is equal to the sum of base current  $I_b$  and collector current  $I_c$ .

Observe that in the common-emitter circuit configuration  $R_e$  is common to both base and collector currents. Accordingly, when  $I_c$  flows through  $R_e$ , a voltage drop is produced that assists the applied bias voltage. Since Ohm's law states that resistance is an  $E/I$  ratio, it is evident that the flow of  $I_c$  increases effective base input resistance. Moreover, inasmuch as an increase in the value of  $R_L$  causes a reduction in  $I_c$ , it follows that base input resistance will decrease as the value of  $R_L$  increases.

It is also evident that if beta decreases, there will be less amplification of the base input current and  $I_c$  will decrease. When the latter occurs, there is less current through  $R_e$  and the effective base input resistance increases as beta decreases.

From the foregoing, you can see that base bias voltage depends upon the rated base input resistance of the transistor, the value of the load resistance being used and the effective prevailing dc beta value. However, in the first analysis, you can disregard second-order effects and assume that the transistor's base input resistance is the rated  $h_{ie}$  value given in the

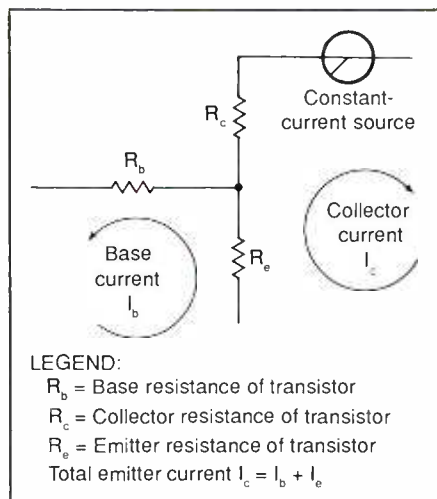

Fig. 5. The traditional  $r$ -parameter symbol for a transistor.

manufacturer's data sheet. In our example,  $h_{ie}$  is rated at 1,500 ohms.

### With Voltage and Current Feedback

You are now in a good position to consider troubleshooting procedures for the basic collector-bias circuit with emitter feedback, as illustrated by the circuit shown in Fig. 6. This circuit employs both voltage feedback and current feedback, with  $R_{b1}$  providing the former and  $R_e$  providing the latter.

In collector-bias circuits, no  $V_{bb}$  source is provided. Collector voltage  $V_c$  serves this purpose in its stead. As might be anticipated, the Fig. 4 circuit has very good bias stability and is quite tolerant of variations in parameter values. It also has low inherent distortion. Its chief disadvantage is that the circuit has relatively low gain.

As far as base voltage is concerned

in Fig. 6, you should note that voltage feedback has the effect of lowering base input resistance and that current feedback has the effect of raising it. Therefore, in the first analysis, you assume that base input resistance will be comparable with the rated  $h_{ie}$  of the transistor. A check of  $C_C$  leakage can be made as previously described by monitoring the base voltage while a temporary short circuit is placed between the left-hand end of the coupling capacitor and circuit ground.

The possibility of leakage resistance  $R_{cb1}$  usually requires a "last-resort" procedure in which one end of  $R_{b1}$  is disconnected from the circuit and its resistance is measured with an ohmmeter. The only exception occurs in the case where the  $R_L$  circuit can be switched completely open so that the apparent resistance of  $R_{b1}$  can be measured in-circuit with a low-power ohmmeter. (Keep in mind, though, that filter capacitors can cause prolonged ohmmeter "crawl" in which the meter reading continues to change.)

Table 2 lists the dc voltage distribution patterns for the Fig. 6 circuit arrangement. There is only one unique group of conditions in this table and that is when beta is low,  $V_c$  goes high,  $V_e$  goes high, and  $V_b$  goes low. Thus, it is easy for you to spot a low beta value, although the other four groups are ambiguous in the first analysis. Stated differently, when  $V_c$  is low with  $V_b$  and  $V_e$  high, the cause could be  $R_{b1}$  low or  $R_{b2}$  high; when  $V_c$  is high with  $V_b$  and  $V_e$  low, the fault could be  $R_{b1}$  high or  $R_{b2}$  low. When  $V_c$ ,  $V_b$  and  $V_e$  are all high, the

Table 2. Dc Voltage-Distribution For Circuit With Voltage & Current Feedback

	$R_{b1}$ High	$R_{b1}$ Low	$R_{b2}$ High	$R_{b2}$ Low	$R_L$ High	$R_L$ Low	$R_e$ High	$R_e$ Low	Beta Low
$V_c$	High	Low	Low	High	Low	High	High	Low	High
$V_b$	Low	High	High	Low	Low	High	High	Low	Low
$V_e$	Low	High	High	Low	Low	High	High	Low	High

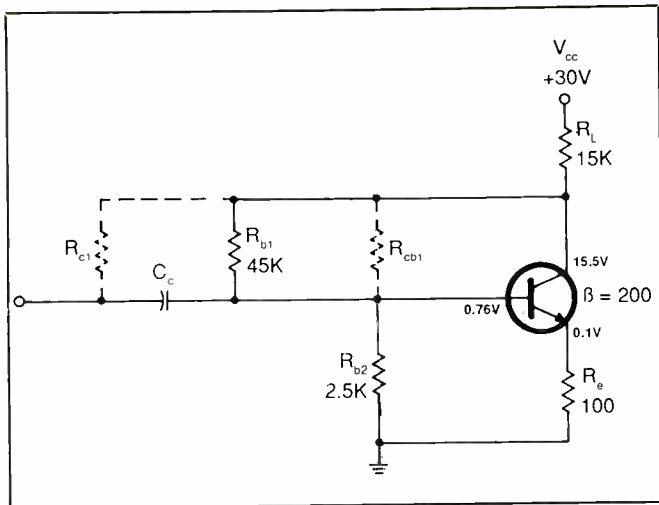

Fig. 6. Basic collector-bias circuit in which no  $V_{bb}$  or  $V_{ee}$  source is used.

fault could be  $R_L$  low or  $R_e$  high; when  $V_c$ ,  $V_e$  and  $V_b$  are all low, the fault could be  $R_L$  high or  $R_e$  low.

At first glance, the dc voltage distribution patterns listed in Table 2 seem to present a "tough-dog" problem. However, there is an independent test that you can use that easily distinguishes between  $R_{be}$  high and  $R_{b2}$  low and vice-versa. This novel trick of the trade consists of comparison between the measured Thevenin resistance of the  $R_{b1}/R_{b2}$  voltage divider and the theoretical Thevenin resistance of the divider.

The measured Thevenin resistance is the net resistance of  $R_{b1}$  and  $R_{b2}$  connected in parallel with each other. The theoretical Thevenin resistance is calculated from the rated resistor

values by means of the product-over-sum formula, which can easily be punched out on a pocket calculator.

You will discover that the measured Thevenin resistance will differ from the theoretical Thevenin resistance in the event that  $R_{b1}$  is high or  $R_{b2}$  is low. Put another way, if  $R_{b1}$  is high, the measured/theoretical ratio will be high and vice-versa. The theoretical value is a median value; the measured value will be higher or lower than the median value. As shown in Fig. 7, a low-power ohmmeter is used to make these measurements to avoid turning on the base-emitter junction of the transistor.

It is helpful to consider a practical example at this point. From service data or resistor color coding, we note

that  $R_{b1}$  has a rated value of 45,000 ohms and that  $R_{b2}$  has a rated value of 2,500 ohms. In turn, the parallel resistance value of these two resistors is theoretically approximately 2,368 ohms. This ideal value is greater than the the measured Thevenin resistance when the value of  $R_{b2}$  is low and is less than the measured Thevenin resistance when the value of  $R_{b2}$  is high.

If the value of  $R_{b1}$  is 45,000 ohms and the value of  $R_{b2}$  is 1,500 ohms, the measured Thevenin resistance is 1,452 ohms. On the other hand, if the value of  $R_{b1}$  is 70,000 ohms and the value of  $R_{b2}$  is 2,500 ohms, the measured Thevenin resistance will be 2,414 ohms.

Since 1,452 ohms is considerably less than 2,368 ohms and 2,414 ohms is considerably greater than 2,368 ohms, the ambiguity is clearly resolved. This trick is based upon the circumstance that the Thevenin resistance consists of a product divided by a sum. With  $R_b$  high, the product increases out of proportion to the sum, and with  $R_{b2}$  low, the product decreases out of proportion to the sum. These conflicting proportions "finger" the cause of the trouble and eliminate the time-consuming "shot-gun" troubleshooting procedure often used.

ME

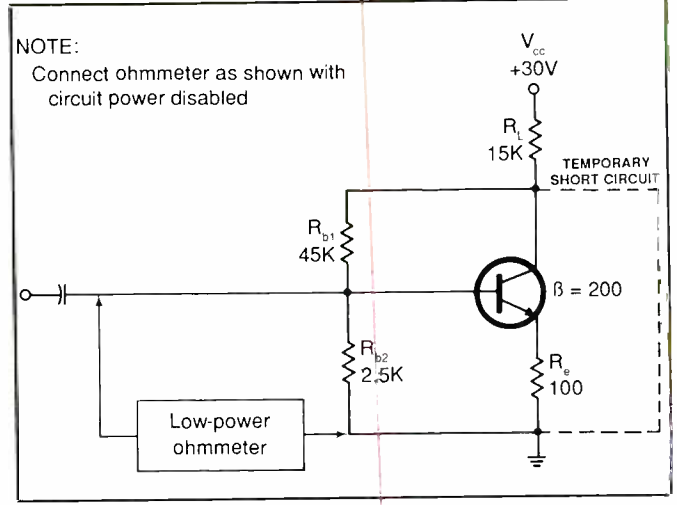

Fig. 7. Test setup for measurement of Thevenin resistance for the bias voltage divider.

NOTE:  
Connect ohmmeter as shown with circuit power disabled

**SUBSCRIBER SERVICE**  
**CHANGE OF ADDRESS**

Planning to move? Please let us know six weeks in advance so you won't miss a single issue of **MODERN ELECTRONICS**

Attach old label and print new address in space provided. Also include your mailing label whenever you write concerning your subscription to insure prompt service on your inquiry

Modern Electronics  
76 N. Broadway,  
Hicksville, NY 11801

**ATTACH LABEL HERE**

NEW ADDRESS HERE PLEASE PRINT

NAME \_\_\_\_\_

ADDRESS \_\_\_\_\_

CITY \_\_\_\_\_ STATE \_\_\_\_\_

DATE \_\_\_\_\_ ZIP \_\_\_\_\_



# A 6-Channel IR Remote-Control System

## Part II (Conclusion)

### *How to build control slave modules*

By Anthony J. Caristi

Last month in Part I of this series, we described a basic TV-receiver/VCR infrared remote-control system that provides on/off control of up to six separate electrically operated devices. In this concluding installment, we focus on how to build several types of slave circuits that will permit you to control virtually any type of device from the system's battery-powered, hand-held transmitter. Each of the slave circuits described here is elementary in nature and is designed to accommodate a limited or single load application. The sum of all circuits presented should satisfy most residential load requirements without any modifications or additions.

#### *The Slave Circuits*

We will deal with each slave circuit individually so that each will be a complete project package in itself. That is, we will discuss theory of operation, followed by complete construction details.

• *Simple Relay Circuit.* Figure 1 illustrates the simplest type of control circuit. It contains a common dc relay that is driven by a transistor. The single-pole, double-throw relay contacts can be used to switch power to any type of load circuit that does not exceed the 2-ampere contact rating of the relay. A readily available relay is specified in the Parts List, but you can substitute another relay that has

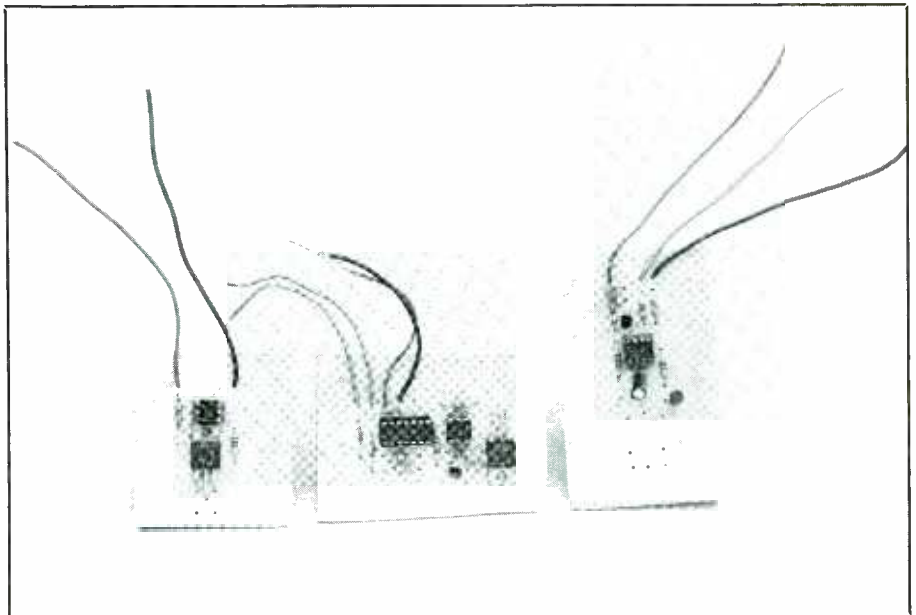

heftier contacts if your application requires greater current. Too, if the application calls for more than one supply voltage, you can choose a relay that has a greater number of contact pairs.

The circuit shown in Fig. 1 offers momentary operation because the relay will be energized only during the time the transmitter pushbutton for the channel to which the relay is assigned is held down. Releasing the transmitter button causes the relay contacts to spring back to the unenergized position.

Power for the relay is supplied by the 9-volt output of the receiver/decoder power supply featured last month. The specified relay has a 9-

volt coil. However, you can substitute a relay with a 5- or 6-volt dc coil if you connect an appropriate voltage-dropping resistor in series with its coil so that the potential applied to the coil does not exceed its dc voltage rating. Determining what value resistor to use is a simple Ohm's law calculation, once you measure the resistance of the relay coil you intend to use. You can also use a relay that has a 12-volt dc coil if it will operate reliably at 9 volts (most 12-volt relays will do this, but check to make sure before purchasing one).

Resistor *R1* connects to the emitter of one of the emitter-follower transistors *Q2* through *Q7* in the receiver/decoder. When the corresponding

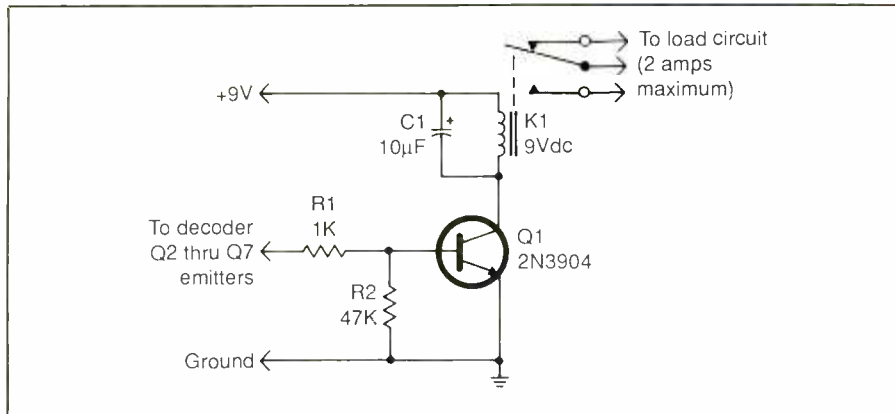

Fig. 1. Simplest type of control circuit contains an electromechanical relay that is driven by a transistor.

transmitter pushbutton is pressed, the potential at the emitter of the driver transistor rises to about +5 volts. This is sufficient to forward-bias relay transistor *Q1* in the Fig. 1 circuit so that collector current flows and energizes relay *K1*.

Shown in Fig. 2 are the actual-size etching-and-drilling guide (A) and wiring diagram (B) for the printed-circuit board for the Fig. 1 relay driver circuit. You can fabricate this and any of the other pc boards presented in this article or you can purchase ready-to-wire boards from the source given in the Note at the end of the Parts List. Guide (A) is laid out for the relay specified for *K1* in the composite Parts List. Hence, if you use a different relay, you will have to modify the layout accordingly.

When wiring the pc board, note in Fig. 2(B) that you must make three connections to the receiver/decoder circuit—to +9 volts, circuit ground and any one of the emitters of driver transistors *Q2* through *Q7*. Be careful not to confuse +9 volts with  $V_{dd}$ , which is the regulated 6.8-volt bus. Also, make certain that the transistor is properly based and electrolytic capacitor *C1* is properly oriented before soldering any of its leads to the pads on the bottom of the board.

The contacts of the relay on the slave module can be used to control ac or dc power to the load. When the

appropriate transmitter button is pressed, the corresponding LED in the driver emitter-follower stage in the receiver/decoder will turn on simultaneously with energization of the relay. If the LED turns on but the relay does not energize, use a high-impedance digital voltmeter or a multimeter set to the dc-volts function to ascertain that you have 9 volts dc applied between the proper terminals on the slave module and that the drive voltage appears at the input of *R1* when the appropriate button on the transmitter is pressed. Also, check to make sure that *Q1* and *C1* are properly oriented.

• **Solid-State Drivers.** The circuits shown schematically in Fig. 3 and Fig. 4 are in many cases a better way to go to provide momentary control of the power to an ac load. For one thing, they are completely solid-state, which means that they have no moving parts to fatigue and wear out, as will happen with an electromechanical relay. Additionally, the optical isolators in these circuits provide electrical isolation between the low-voltage receiver/decoder control circuit and the load. Hence, you can safely control 117-volt ac lamps, appliances and other ac-line-powered loads with the low voltage circuit of the receiver/decoder.

The optoisolators used in these circuits contain a light-emitting diode

## PARTS LIST\*

### Semiconductors

- D1,D2—1N4148 or similar general-purpose silicon diode
- IC1,IC2,IC5,IC8—MOC3011 or equivalent optical isolator
- IC3—H11D4 or equivalent optical isolator
- IC4—CD4001BE quad 2-input NOR gate
- IC6,IC7—LM555 timer
- LED1—Visible 2-volt, 20 mA light-emitting diode
- Q1,Q6,Q7,Q8—2N3904 or similar npn silicon transistor
- Q2,Q5,Q9—2N6342 or similar triac
- Q3—TIP31 or similar npn silicon transistor
- Q4—BS170 or equivalent N-channel enhancement-mode field-effect transistor

### Capacitors

- C1,C4—10-µF, 25-volt electrolytic
- C2,C3,C5—0.1-µF, 50-volt ceramic disc
- $C_t$ —Value selected for desired timing duration (see text)

### Resistors (1/4-watt, 10% tolerance)

- R1—1,000 ohms
- R2,R7,R8,R13,R17—47,000 ohms
- R3,R4,R6,R20—100 ohms
- R5,R10,R11,R21—150 ohms
- R9—220,000 ohms
- R12,R14,R16,R18—10,000 ohms
- R15—1,000 ohms
- R19—470 ohms
- $R_t$ —Value selected for desired timing (see text)

### Miscellaneous

- K1,K2—Spdt 9-volt dc relay (Radio Shack Cat. No. 275-005 or similar; printed-circuit boards; sockets for ICs and optical isolators; suitable enclosures (optional); machine hardware; hookup wire; solder; etc.

**Note:** The following items are available from A. Caristi, 69 White Pond Rd., Waldwick, NJ 07463: Ready-to-wire pc boards, \$8.95 each (specify which circuits), MOC3011 optical isolator, \$5 each (specify ac or dc); CD4001BE, \$2; LM555 timer, \$2; transistors, \$3 each (specify which needed). Add \$2 P&H per order. New Jersey residents, please add state sales tax.

\*This is a composite Parts List. Use only those components specified in the specific schematic diagrams of the slave modules you wish to build.



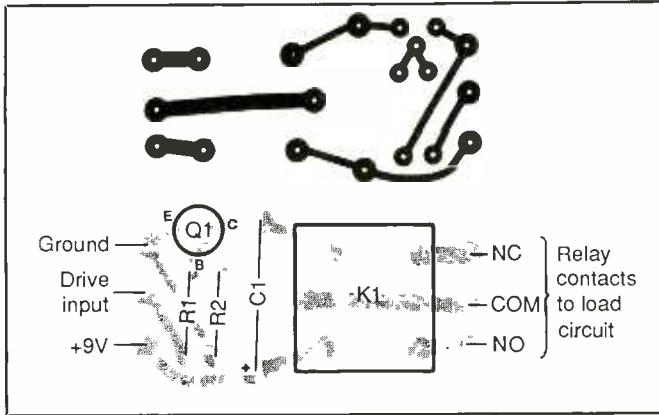

Fig. 2. Actual-size etching-and-drilling guide (upper) and wiring diagram (lower) for Fig. 1 circuit.

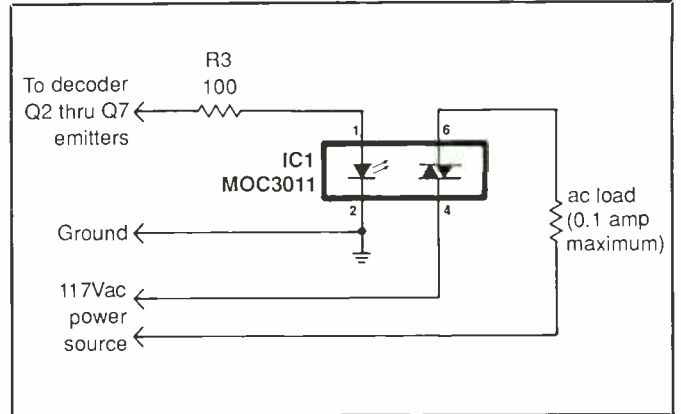

Fig. 3. A simple circuit that can control ac power to a load that draws up to 0.1 ampere.

that is driven by an emitter-follower transistor driver in the receiver/decoder. The LEDs in the optoisolators require at least 10 milliamperes of drive current to reliably switch on the triacs built into these devices. For this reason, it is necessary when using the circuits to slightly modify the driver transistor circuit of any channel in which an optoisolator is used.

To effect the modification, disconnect the LED associated with the selected receiver/decoder driver transistor. Then change the value of the base resistor of the driver transistor from its originally specified 220,000 ohms to 47,000 ohms. This value change ensures that the LED in the optoisolator is supplied with sufficient drive current to activate the internal triac.

The triac contained in the optoisolator is a low-current unit that is rated to handle up to 0.1 ampere. This triac responds to the light generated by the internal LED and switches "on" when the LED is activated. Once triggered on, the triac permits current to flow into the load. Bear in mind that the circuits depicted in Fig. 3 and Fig. 4 should be used only for ac loads that require 117 volts or less.

The basic Fig. 3 circuit is rated to handle loads that require up to 0.1 ampere, which limits its application to a very light load of 12 watts or less.

Though 117-volt lamps of this power level are available, they are not common nor desirable in many situations. However, you can use this circuit to drive the coil of an ac relay that, in turn, can safely carry whatever heavier load you wish to control. Such a configuration would also permit multiple-pole switching, which is not directly attainable with the optoisolator.

When load current for the intended application exceeds 0.1 ampere, the Fig. 4 circuit proves to be more useful than does the Fig. 3 circuit. In this circuit, the optoisolator's internal triac is used to provide a gate signal to a second triac that has greater power-handling capability. The second triac then controls the load current. You can use any triac externally that can handle the required load cur-

rent, but be sure to use some heat sinking in applications where the load current exceeds 2 amperes. The triac specified in the Parts List for this circuit is rated to carry 8 amperes, but it will overheat at that current unless a suitable heat sink is used to siphon off and dissipate the heat.

If your intended application is to control a dc load, you can use the circuit shown schematically in Fig. 5. This circuit uses an optoisolator that is different than those specified for the Fig. 3 and Fig. 4 circuits. It has a light-activated npn transistor instead of a triac and, thus, is capable of controlling a dc current.

To provide a reasonable current to drive loads up to 3 amperes dc, Q2 has been added to the Fig. 5 circuit in a Darlington configuration. The low-current transistor inside the optois-

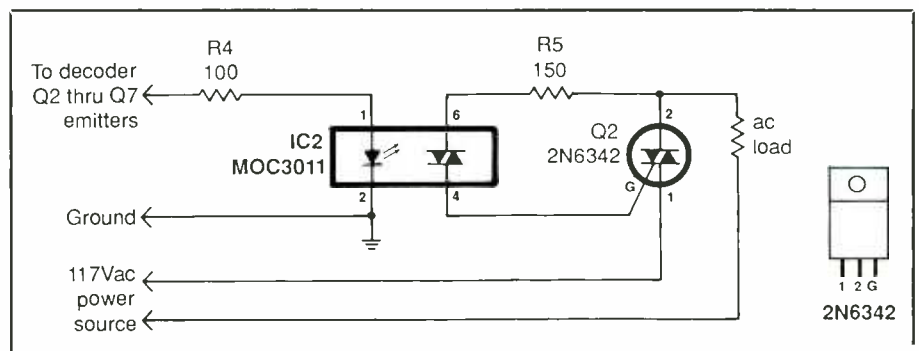

Fig. 4. This control circuit can handle ac loads that exceed 0.1 amp

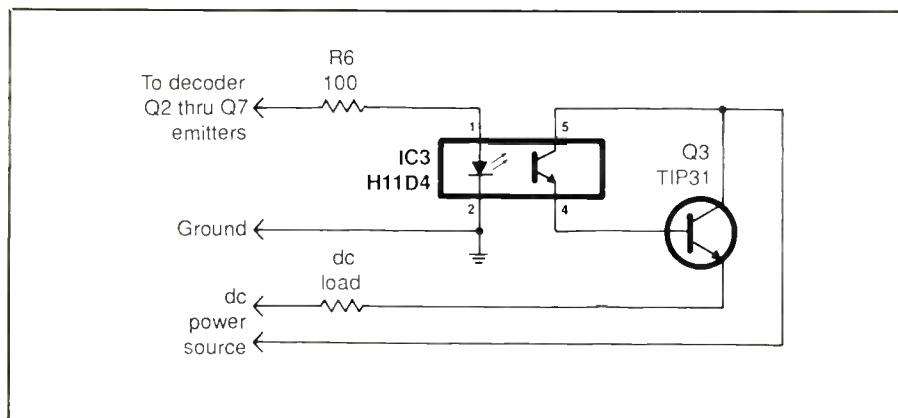

Fig. 5. This circuit controls power to a dc load using a Darlington transistor arrangement to handle up to 3 amperes of dc current.

lator drives base current into *Q2*. In turn, *Q2* controls the load current, which must be 3 amperes or less if no heat sinking is used on *Q2*.

You can build the solid-state driver circuits just discussed on printed-circuit boards made using the actual-size etching-and-drilling guides given in Fig. 6. Guides (A), (B) and (C) are for the Fig. 3, Fig. 4 and Fig. 5 circuits, respectively. Wiring guides for the three pc boards are shown in Fig. 7 and are (A), (B) and (C) keyed accordingly.

When wiring these boards, make sure you install polarized components in the correct orientations. A socket is recommended for each six-pin optical isolator. Since six-pin DIP IC sockets are not readily available, you might have to cut down a standard socket that has a greater number of pins or use Molex Soldercon sockets. Also, note that *Q2* in guide (C) must be installed on the dc slave module board up-side down for correct orientation.

The optoisolator in the slave module is driven by the selected channel's emitter-follower transistor in the receive/decoder. This will require a two-conductor cable to effect the connections between the circuit-board assemblies. Be sure to observe proper connections because a reversal of these two wires will prevent the

LED in the optoisolator from operating and, thus, that channel from responding to the command from the transmitter.

If you experience a problem in operating the load circuit, measure the voltage between pins 1 and 2 of the optoisolator as you hold down the appropriate transmitter pushbutton. During this test, you should obtain a reading of about 1.5 volts, which indicates that the optoisolator is being activated. If you carefully short together the output pins of the optoisolator (pins 4 and 6 of the ac module, or pins 5 and 6 of the dc module), the load should energize.

If you encounter any problems getting any module to operate properly, always begin checkout with a careful review of component installations (especially orientations in polarity- and basing-sensitive components) and soldering. Also, make sure that the decoder driver transistor circuit was modified as instructed above; if it is correct, try a new optoisolator.

• **Latched Control Circuit.** The slave circuits so far discussed are all momentary-action in nature, activating the load for only as long as the appropriate transmitter pushbutton switches are held down. If you wish to turn on or off a device with a simple push of a switch and have it remain in the condition selected even after the trans-

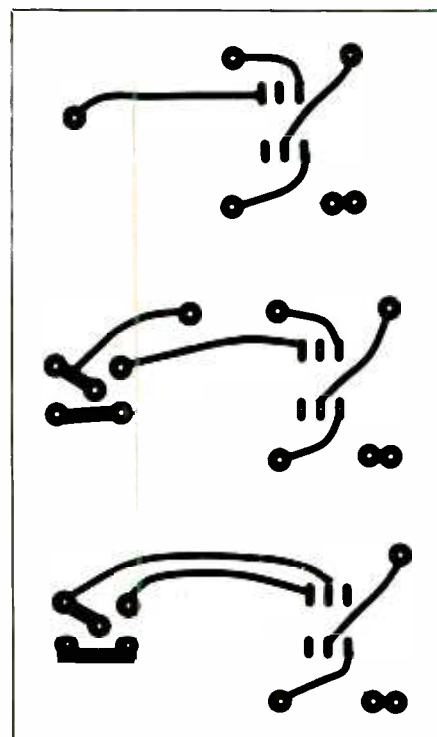

Fig. 6. Actual-size pc guides for Fig. 3 circuit (upper), Fig. 4 circuit (center) and Fig. 5 circuit (lower).

mitter switch is released, you need a latching circuit. To accomplish this, two discrete controls are required—one for on and the other for off. Thus, two transmitting channels are needed to implement this dual function, as illustrated in Fig. 8.

Latching action is provided in Fig. 8 by a pair of NOR gates that are configured as a common bistable multivibrator or flip-flop. Such a circuit has two stable states, each depending upon the logic levels fed to the inputs of the IC at pins 1 and 6. The outputs of the gates at pins 3 and 4 always assume opposite logic levels and remain in the selected conditions until the proper input pin is driven with a logic 1 pulse.

Each input of the latching circuit is driven by its own emitter-follower stage in the receiver/decoder, such as channels A and B. Under quiescent operating conditions, when no transmitter pushbutton is pressed, the logic level at both inputs of the circuit is



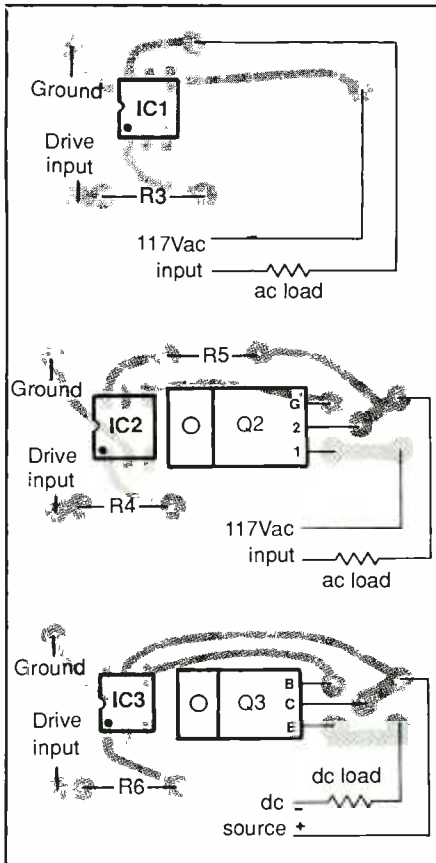

Fig. 7. Printed-circuit wiring guides for Fig. 3 circuit (upper), Fig. 4 circuit (center) and Fig. 5 circuit (lower).

0 and the flip-flop remains as it was when it was last triggered.

Assuming that the present state of the flip-flop circuit represents a logic 0 condition at pin 3 of *IC4A*, field-effect transistor *Q4* has zero bias fed to its gate, which results in no current flow between its drain (D) and source (S). This extinguishes the LED in optoisolator *IC5* and, thus, no power being delivered to the load.

When the transmitting channel that controls pin 6 of *IC4B* is activated, the resulting logic 1 level on pin 6 causes the flip-flop to toggle and output pin 4 of the gate to assume a logic 0 condition. Simultaneously, pin 3 goes to logic 1 and the circuit remains in this state even after the transmitting pushbutton is released.

The change in logic level at pin 3 of *IC4A* forward biases *Q4*, which turns on the LED in the optoisolator. A LED connected in series with the drain of *Q4* provides visual indication that the circuit is energized. The triac is switched on and completes the power feed so that current flows into the load.

In a similar manner, when the al-

ternate transmitter pushbutton controlling pin 1 of *IC4A* is activated, the flip-flop is toggled to its opposite logic state, disconnecting power from the load. As you can see, the load can be switched on and off repeatedly as long as the transmitting pushbuttons are alternately activated.

The actual-size etching-and-drilling guide and wiring diagram for the latching circuit are shown in Fig. 9. When wiring this circuit, be sure to use sockets for the optoisolator and integrated circuit, and pay strict attention to the orientations of the polarized components. Just one component placed backwards in the circuit will prevent that channel from operating.

Power for the Fig. 8 circuit is obtained from the regulated  $V_{dd}$  dc source in the receiver/decoder. Two additional wires are needed to provide the drive signals to *IC4*. The load can be powered by any 12- to 117-volt ac source.

To provide solid logic levels to the inputs of the slave module, the two LEDs in the selected transmitter channels should be disconnected. A

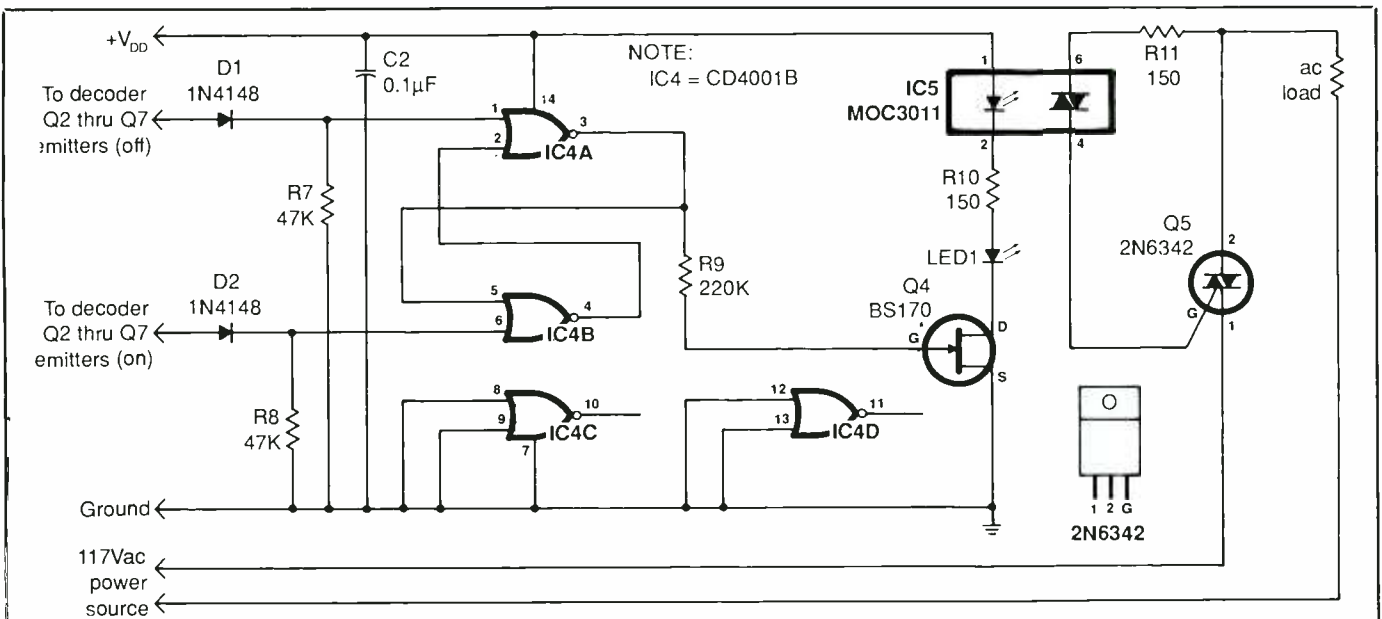

Fig. 8. This latched control circuit uses two transmitter/receiver channels to lock on and off power to load. Previous circuits give momentary action.

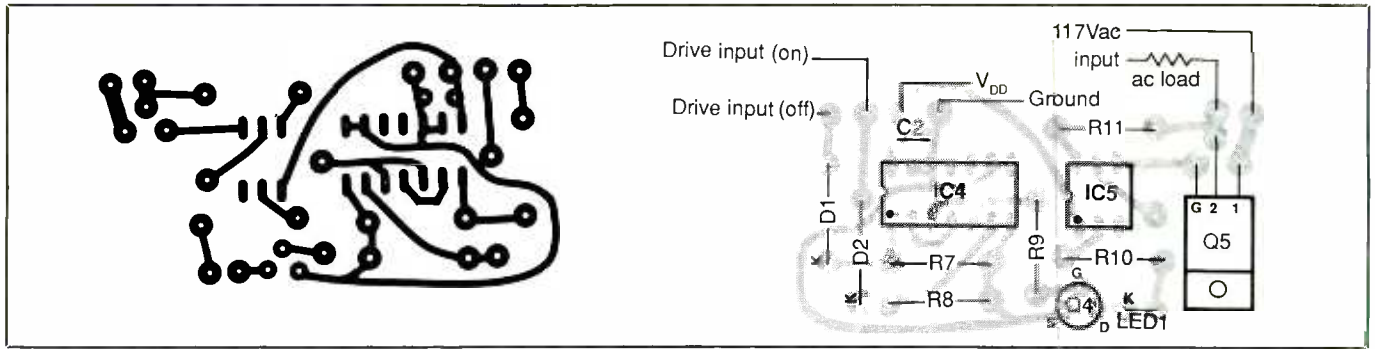

Fig. 9. Actual-size etching-and-drilling guide (left) and wiring diagram (right) for pc board used to assemble Fig. 8 circuit.

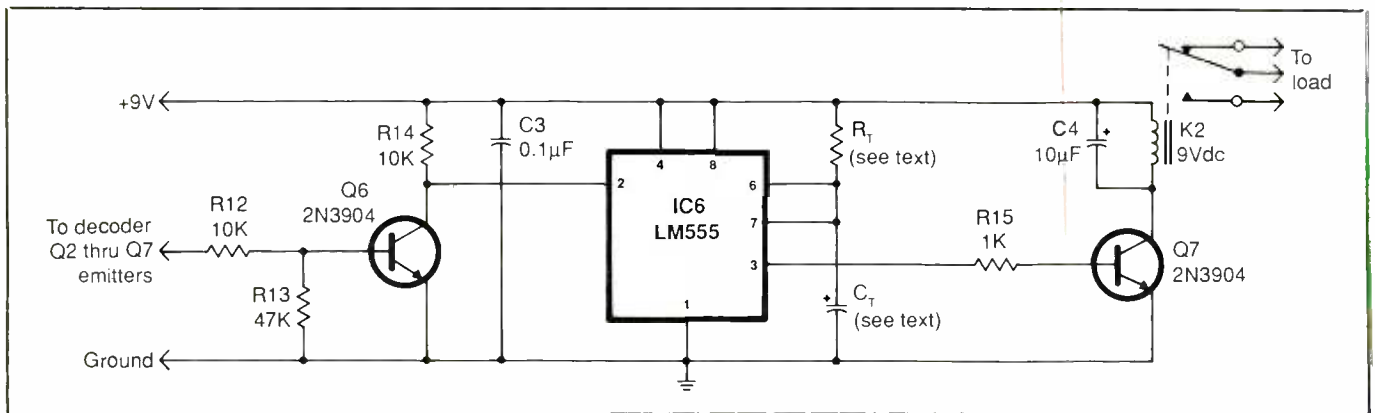

Fig. 10. This timed output pulse circuit latches power on for a predetermined time using only one transmitter/receiver channel. It is designed to use a standard electromechanical relay.

LED is shown in the slave module to provide visual indication of the status of the latching circuit.

If you experience a problem with this slave module, check the logic levels at the inputs as each appropriate transmitter pushbutton is pressed. If the LED in the slave circuit operates normally, turning on and off as the transmitter channels are alternately energized, the problem lies with the optoisolator or output circuit.

To troubleshoot this circuit, carefully short together pins 4 and 6 of the optoisolator to ascertain that the load turns on when the optoisolator is activated. Also, check load wiring to be sure that it agrees with Fig. 8. If the wiring is correct, try replacing IC5.

• **Timed Output Pulse.** The final slave circuit, shown schematically in Fig. 10, utilizes just one transmitting

channel and permits a load to be powered for a predetermined period of time when its transmitter pushbutton is pressed and then released. This is accomplished through use of the common 555 timer IC.

In Fig. 10, IC6 is configured as a monostable or "one-shot" multivibrator. When the appropriate receiver/decoder driver transistor (Q2 through Q7) is activated, the resulting signal fed to the base of Q5 in the slave circuit causes the transistor to saturate. This results in a near-zero voltage at the collector and triggers on IC6.

When the circuit is dormant, the voltage at pin 3 of IC6 remains at zero. Once the chip is triggered by pressing the transmitter pushbutton, the potential at pin 3 rises to about +8 volts. At the same time, capaci-

tor  $C_t$  is permitted to charge through  $R_t$  at a rate determined by RC time constant  $R_t C_t$ . When the capacitor reaches about  $\frac{2}{3}$  of the supply voltage, it is suddenly discharged by a transistor within the IC and pin 3 of that chip returns to its dormant state of 0 volt. The cycle repeats only when a new signal appears at the base of Q5 in response to pushing the transmitter button.

During the time pin 3 of IC6 is in its active state, Q6 is forward-biased and K2 is energized. The contacts of the relay control power to the load circuit. This circuit is capable of providing timed cycles of less than 1 second to 15 minutes or more. For very short timing cycles, it is important that the transmitter switch be released before the end of the cycle. If it is not released in time, a second cycle



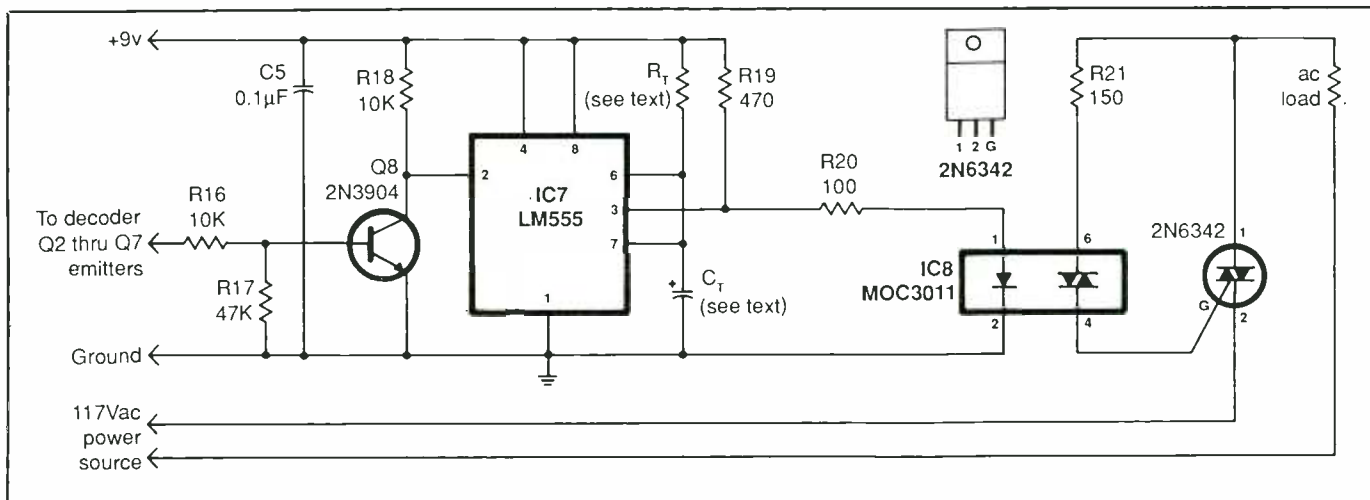

Fig. 11. This timed output pulse circuit replaces the electromechanical relay with an optical isolator.

will automatically begin.

The time required for IC6 to complete one cycle is easily calculated using the formula  $T = (1.1)(R_t)(C_t)$ , where T is time in seconds,  $R_t$  in ohms and  $C_t$  in Farads. For relatively long timing cycles (1 minute or longer), you may use resistor values as high as 4.7 megohms if necessary.

There is almost no limit of the value of the capacitor that can be used. However, if you need a timed cycle duration of greater than 1 or 2 minutes, use low-leakage electrolytic or tantalum capacitors. This will provide the greatest accuracy and repeatability of your cycle. Timed cycles of 15 minutes duration are easily obtained using low-leakage electrolytic capacitors.

The Fig. 10 circuit is designed to drive a standard electromechanical relay. An optical isolator can also be

used, as shown in Fig. 11. Here, the positive output voltage of IC7 drives the LED in the optoisolator. As with the previous circuits that use this component, the load is powered through the action of the light-sensitive triac or transistor within the optoisolator.

Figure 12 gives the actual-size etching-and-drilling guides for the pc boards needed for the relay and optical-isolator circuits, and Fig. 13 shows the wiring details for the same circuits letter-keyed in the same way.

When wiring these circuits, use sockets for the integrated circuits and optical isolator. Again, make sure the ICs and optoisolator are properly oriented as you plug them into their respective sockets and that no pins overhang the sockets or fold under between devices and sockets.

Wire the timed slave modules to

the +9-volt output of the receiver/decoder power supply. One additional connection from one of the Q2 through Q7 driver emitters is required for each module as well. For this application, it is not necessary to disconnect the LED of the driver emitter-follower transistor in the receiver/decoder.

If you have a problem with a timed slave module, check the input at R16 to be sure that it is driven by a signal of about +5 volts when the appropriate transmitter pushbutton is pressed. Measure the potential at pin 3 of the timer IC to determine that it rises to about +8 volts when the IC is triggered. If you obtain a normal indication, check the wiring to the load circuit. If the module still does not operate as it should, try replacing the

(Continued on page 81)

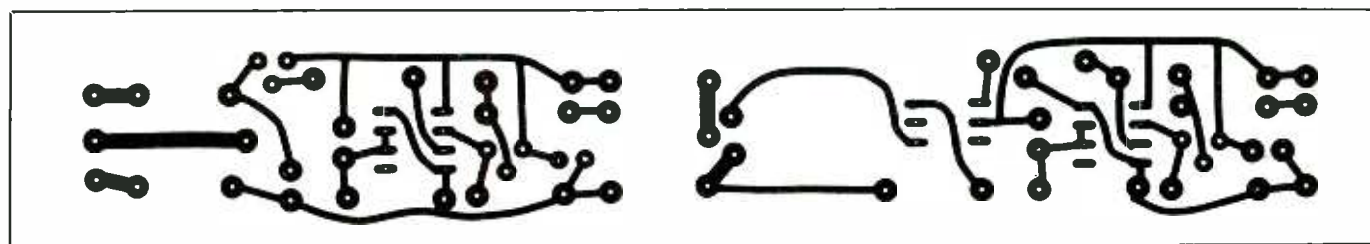

Fig. 12. Actual-size etching-and-drilling guides for fabricating pc boards for Fig. 10 (left) and Fig. 11 (right) circuits.

# A Smart Weather Monitor (Part II)

## Construction details for the CPU and display modules

By Thomas R. Fox

Last month in Part I of this article, we gave operating details for the two main modules that make up this expandable stand-alone multifunction MCU-based real-world instrument that automatically records temperatures and can predict them as well. This month, our focus is on construction of these modules. Future issues will deal with operational details and construction of the remaining modules—an A/D memory-expansion board and the input keyboard—and physical placement of the various sensors used with the project and how to use WISARD.

### Construction

Though the WISARD is a fairly complex project in terms of component count, you can build its various modules using any of the wiring techniques traditionally used. If you wish, for example, you can fabricate a printed-circuit board for each module. Otherwise, you can use perforated project board that has holes on 0.1-inch centers and suitable Wire Wrap or soldering hardware. Whichever way you go, though, it is a good idea to use sockets for all DIP integrated circuits and LED displays.

If you fabricate the pc boards, use the actual-size etching-and-drilling guides shown for the CPU and display module boards in Fig. 4 and Fig. 5. You can economize on the cost of the project by using a single-sided pc blank for the CPU module board and wire jumpers, as was done for the

prototype of the project. Otherwise, the conductor pattern for the top of the board, shown in Fig. 4, can eliminate the large number of jumpers if you use a more-expensive double-sided pc blank instead.

While you are at it, fabricate the moisture sensor from a small piece of single-sided pc blank, using the actual-size artwork given in Fig. 6. You can purchase a ready-to-wire display module board from the source given in the Note at the end of the Parts List, but neither the CPU module board nor the moisture sensor are commercially available at this time.

From here on, we will assume printed-circuit construction. Start construction by wiring the CPU module board, using Fig. 7 to guide you. (If you are using perforated-board construction, use this illustration to guide you in laying out the components on it.) Start wiring the CPU module board by installing and soldering into place the various IC sockets. Do *not* install the ICs in the sockets until after voltage checks have been performed.

Proceed with wiring the CPU module board by installing and soldering into place the resistors, trimmer potentiometers, capacitors, diodes and other two-terminal devices. Make certain that all polarity-sensitive components (electrolytic capacitors, diodes, etc.) are properly oriented before soldering their leads to the copper pads on the bottom of the board. Then install and solder into place the two crystals.

Note in Fig. 7 that two jumper wires must be installed on the CPU module board, regardless of whether

or not you use a double-sided board. Both are shown as heavy lines. The one near the IC16 socket offers no options and should be installed and soldered into place in the indicated location exactly as shown. The other is the EPROM type selector. If you are using a 27128 EPROM, install this jumper from the COMMON hole to the 27128 hole as shown. If you are using a 27256 EPROM and use a longer jumper wire to bridge from the COMMON hole to the 27256 hole to the right of the IC1 socket.

Once you have taken care of the first two jumpers, install and solder into place the remaining jumper wires if you are using a single-sided board. Use insulated solid hookup wire for *all* jumpers. If you are using double-sided board, you must bridge the conductors from the bottom of the board to the top and vice-versa as needed. Solder short lengths of bare hookup wire at each location where a hole is indicated in the top conductor pattern in Fig. 4.

Finish preliminary wiring of this circuit-board assembly by installing and soldering into place the RS-232 connector in the location indicated near the top edge, single-row headers at positions identified as P1001, S406, S407 and S408; and double-row headers at D15D and D15K.

*Fig. 4. Actual-size etching-and-drilling guides for top and bottom of the double-sided CPU module printed-circuit board. Single-sided board can be fabricated, using guide at left and replacing top guide with insulated wire jumpers.*



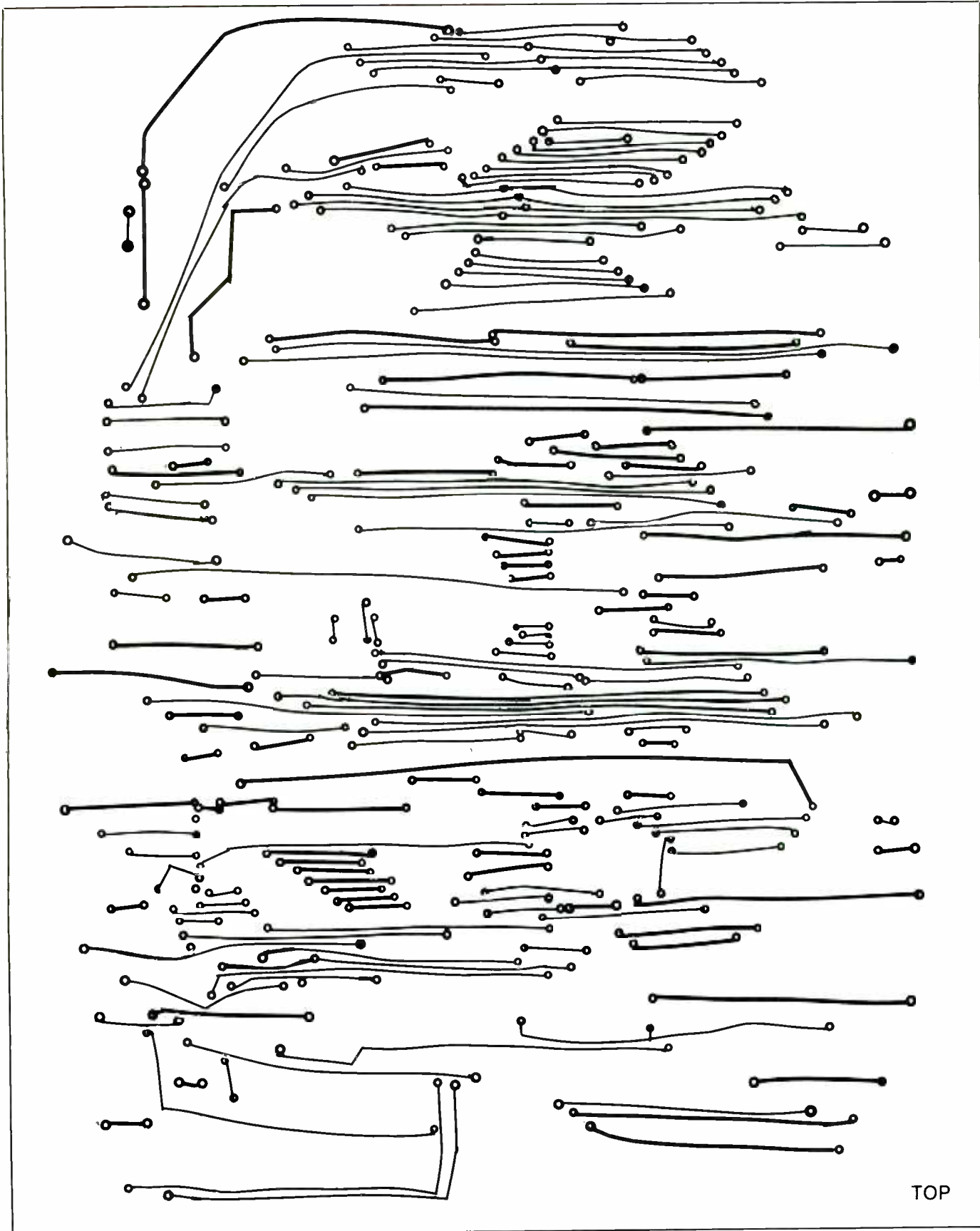

TOP

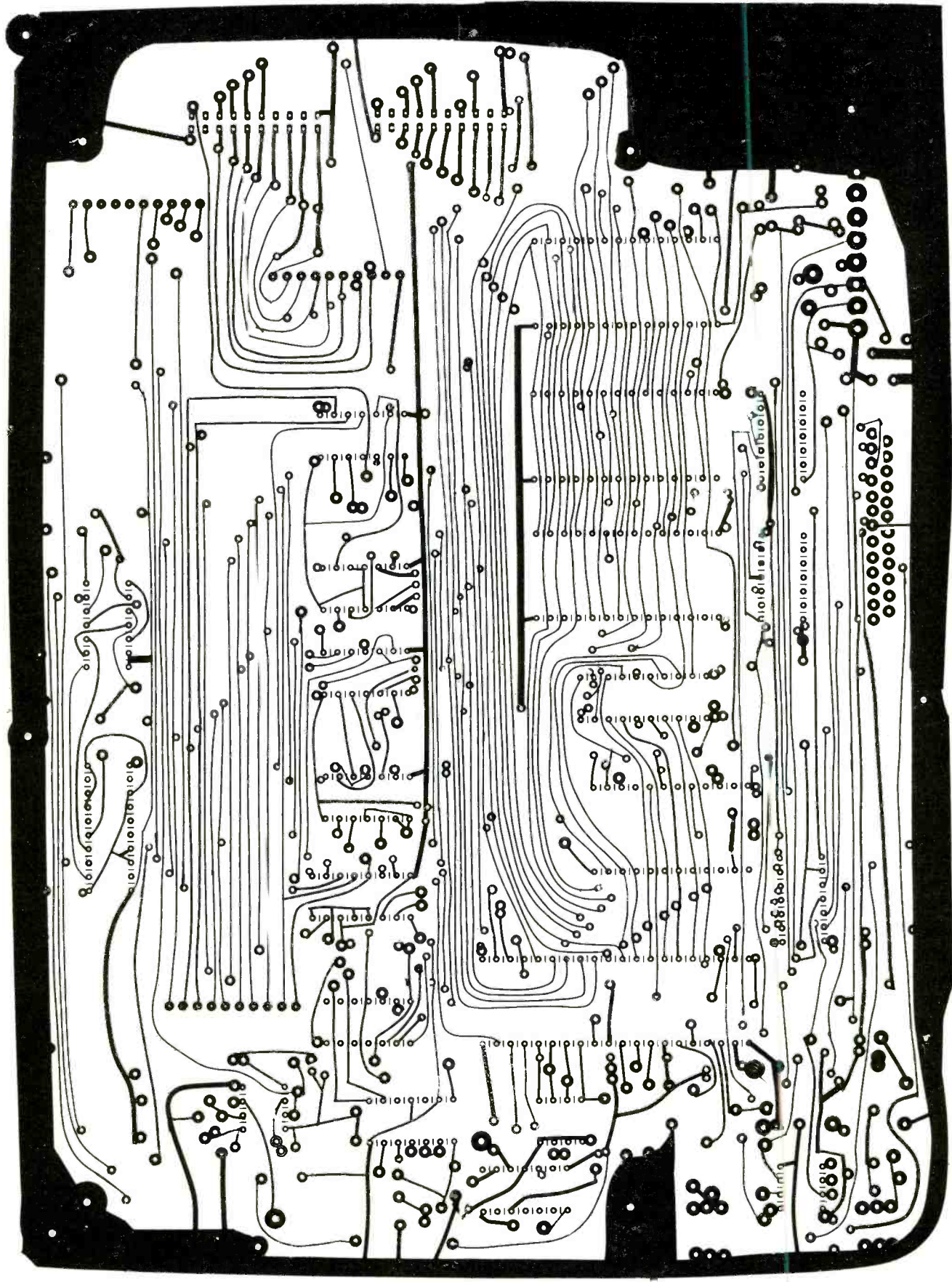

BOTTOM



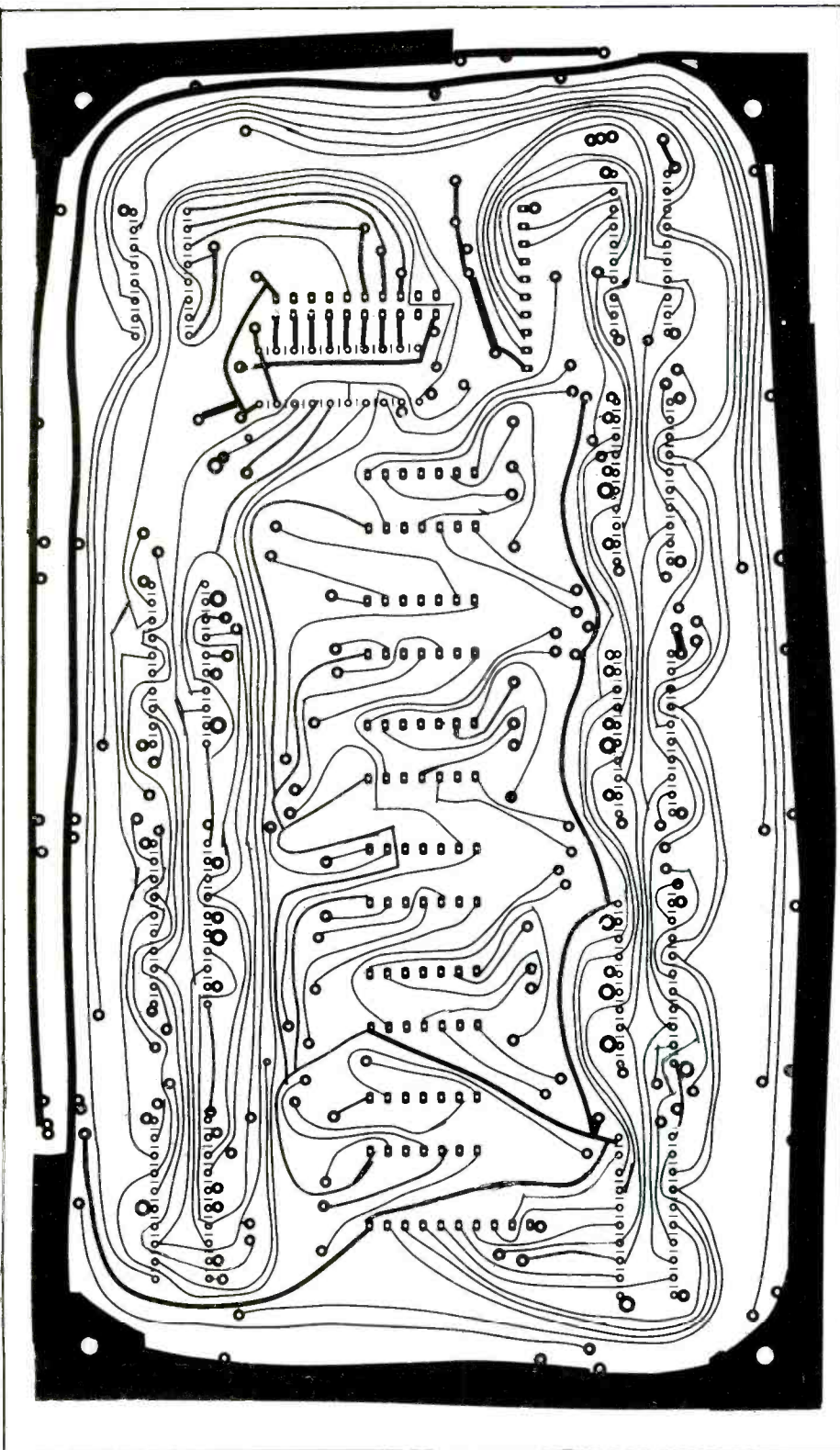

Fig. 5. Actual-size etching-and-drilling guide for display module printed-circuit board.

After working on the CPU module board, wiring of the display module board is almost routine. Once again, begin wiring this board by installing and soldering into place the IC and display sockets. Do *not* install the

ICs or LED numeric displays in the sockets until after voltage checks have been performed.

Continue wiring the board by installing and soldering into place the resistors. Note here that, except for

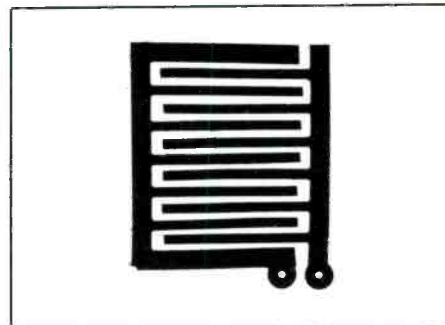

Fig. 6. Actual size fabrication guide for moisture sensor. Use single-sided pc blank to make the sensor.

R149, R150 and R151, resistor locations are not numbered. Their locations are simply identified by the letter "R" because they all have the same 330-ohm value. This greatly simplifies assembly because there is no need to interpret color codes for a variety of resistance values.

Once you have installed the resistors, proceed to installation of the capacitors. Then install single-row headers at locations P5016 and P5017 and a double-row header at location P15D. All three connectors mount on the *solder* side of the board. Also, it is a good idea to remove pins 9 and 12 of both headers. Finish wiring this circuit-board assembly by installing and soldering into place the various wire jumpers. Again, use insulated solid hookup wires for the jumpers.

### Preliminary Tests

WISARD requires a power supply that can deliver +5 volts at 1 ampere, -5 volts at 100 milliamperes, and +12 volts at 100 milliamperes, all regulated. There are a number of high-quality, low-cost power supplies available from a variety of sources, including surplus parts/equipment suppliers, that are suitable for use with this project. The supply mentioned in the Note at the end of the Parts List is suitable for powering several WISARD projects simultaneously.

To make preliminary voltage



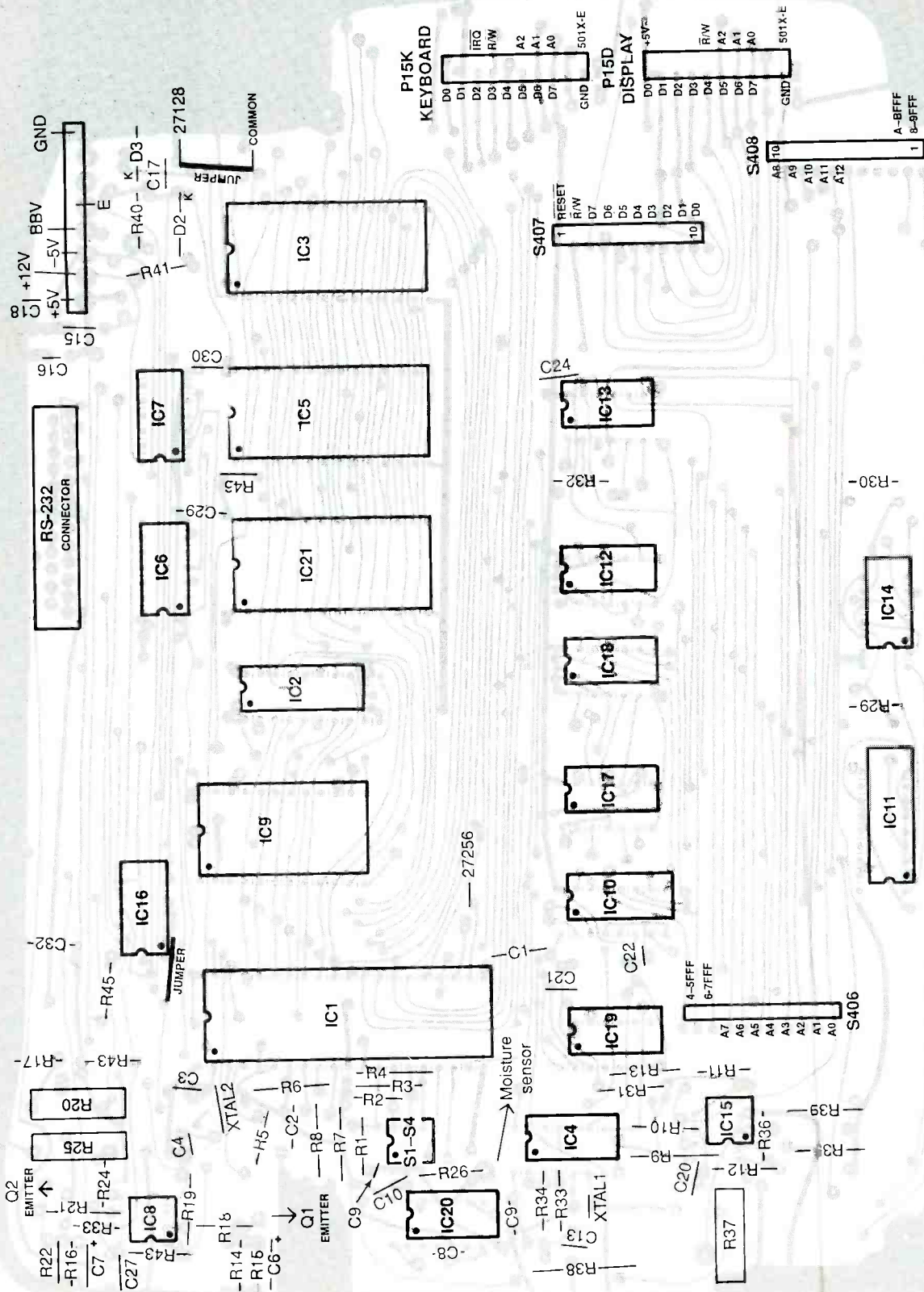

Fig. 7. Wiring guide for CPU module board.

checks, you need a dc voltmeter or a multimeter set to the dc-volts function. Connect the meter's common probe to a suitable point on the CPU module circuit board that is supposed to be at ground potential. Install fully charged Ni-Cd cells in the B1 holder. You should obtain a meter reading of between +3.6 and +4.5 volts when you touch the meter's "hot" probe to the following points on the CPU module board: cathode lead of D3, pin 28 of the IC1 socket, pin 24 of the IC9 socket, pin 5 of the IC12 socket, and pin 10 of the IC14 socket.

Disconnect the battery from the circuit and plug IC15, an LM393, into its socket. Make sure it is properly oriented and that no pins overhang the socket or fold under between IC and socket. This done, connect the power supply to the CPU module board and apply ac power. Connect the meter's common probe to circuit ground and touch its "hot" probe to pin 3 of IC15 as you adjust R37 for a reading between +2.7 and +2.9 volts. Be sure to use a high-impedance meter with an input resistance of at least 1 megohm.

After setting R37, check that the potential at pin 1 of IC15 is greater than +4 volts. If so, disconnect ac power from the circuit while holding the meter's "hot" probe against pin 1 of IC15 and observing the meter's display. With ac power removed, the measured potential should drop to less than +0.8 volt.

Now, touching the meter's "hot" probe to the following socket pins should yield a reading of +5 volts: pin 14 of all 14-pin sockets (except IC7, IC8, and IC15), pin 20 of all 20-pin sockets, pins 7 and 21 of the IC1 socket, pins 1 and 3 of the IC3 socket, pin 28 of the IC5 socket, pins 6 and 16 of the IC10 socket, pin 8 of the IC8 and IC15 sockets, and pin 28 of the IC21 socket. Additionally, you should obtain readings of -5 volts at pin 1 and +12 volts at pin 14 of the IC7 socket.

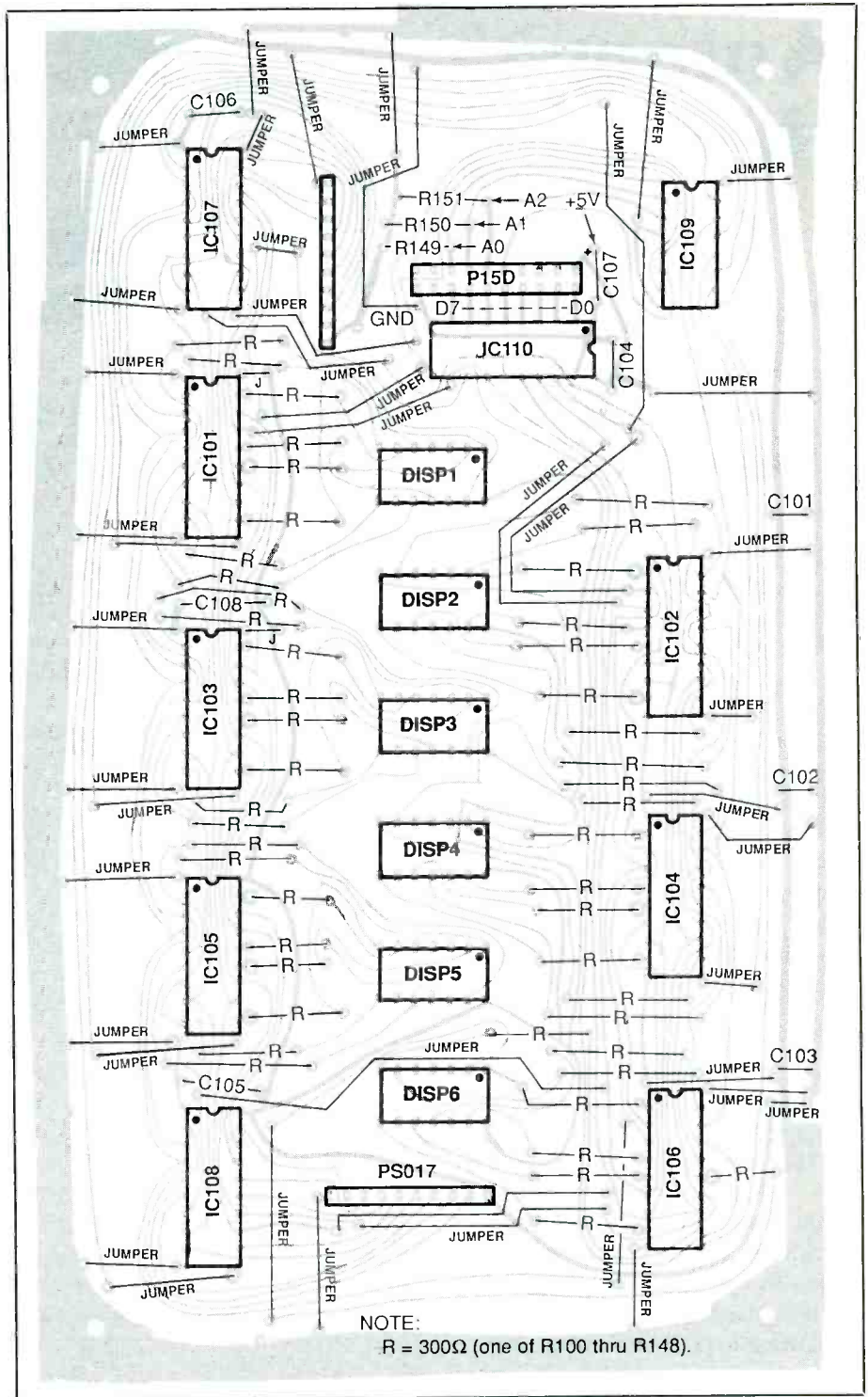

Fig. 8. Wiring guide for display module board.

If you do not obtain the appropriate voltage reading at any of the cited points in the circuit, power down the CPU module board and carefully check it out for components installed

in the wrong locations and/or orientations and proper soldering of all points on the board. Do not proceed

(Continued on page 82)

# Automatic Headlamps Circuit

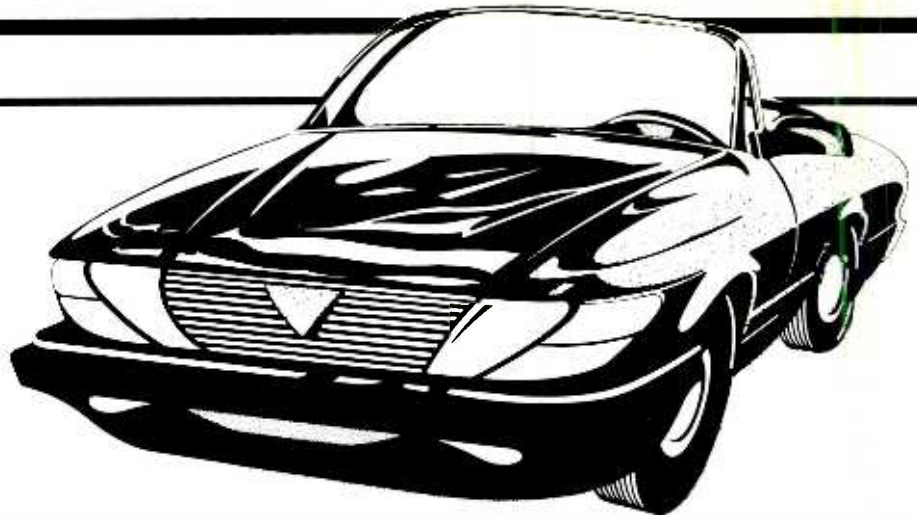

*Automatically turns on your car's headlights when you turn on the ignition and disables them when you turn off the ignition*

By Kenneth R. Cooper

Some time ago, in the interest of driving safety, I started driving my car with its headlights on at all times. I made this decision because it is sometimes difficult for other drivers to see my small dark-colored car. Everything went as planned until the first time I found I had a "dead" battery, the result of forgetting to turn off my headlights when I parked my car overnight. This was enough to spur me to find or design a device that would automatically disable my headlights when I parked for the night, a feature of many luxury-class cars. As it turned out, designing the device was a simple matter.

The Automatic Headlamps Circuit described here accomplishes what I had in mind, simply and inexpensively. Because there are variations in ignition systems from one manufacturer to another, several are discussed here. There are enough to accommodate just about any car on the road, whether domestic or imported, except those from Chrysler Motors (possible use for these is discussed).

## About the Circuit

Checking over the schematic diagram of the headlights circuit in my

car revealed that it would be relatively easy to install a relay that could be energized only when the vehicle's engine was running. Thus, a relay could be used to control the headlights.

Shown in Fig. 1 is the alternator circuit of my Chevette. The "Charge" indicator lamp is connected between the ignition switch and Terminal 1 of the alternator. Turning the ignition switch to "on" causes the lamp to light, indicating that the lamp itself is functional. After the ignition catches and the engine continues to run, the lamp extinguishes.

This means that the charging circuit is operating.

Terminal 1 of the alternator connects internally to the regulator circuit and the rotor. Thus, it "sees" a low resistance to ground. When the ignition switch is closed ("on"), the lamp lights up because current flows through it to ground.

When the engine starts, the alternator begins to produce three-phase alternating current in the stator windings. This voltage is rectified by the six diodes. When the voltage is great enough in magnitude, current

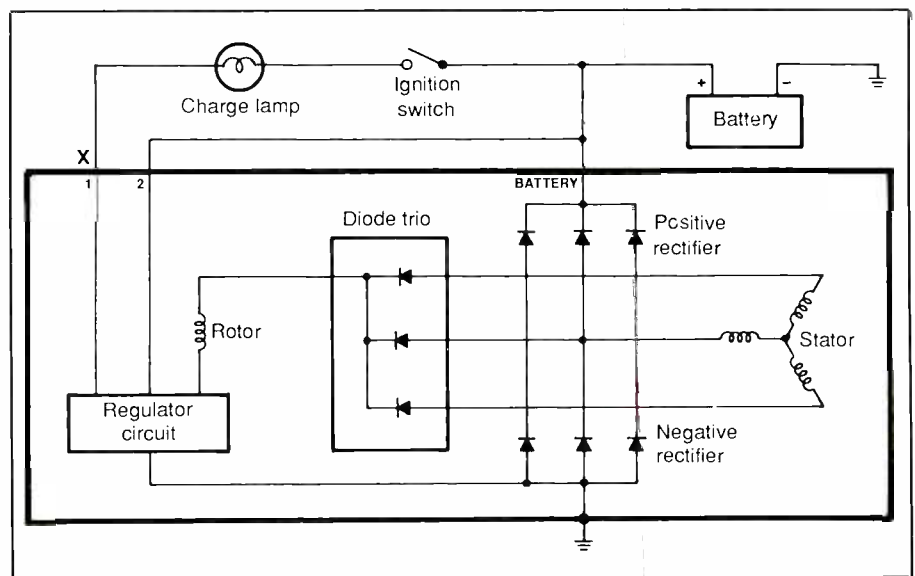

Fig. 1. Details of 1981 Chevette charging circuit.



flows into the battery. At the same time, current flows through the trio of diodes into the rotor. The lamp now extinguishes because it has the same potential at both ends of it and cannot conduct a current.

Alternator Terminal 1, which is at or near ground potential with the engine off, will be at battery potential when the engine is running. This provides the key to automatic control of your car's headlights.

If the coil of a relay is connected between alternator Terminal 1 and vehicle ground, the relay will energize whenever the engine is running. This relay's coil voltage rating must be the same as the 12 volts dc of the battery, and its contacts must be rated to handle at least 10 amperes.

The relay should have two sets of normally open contacts. One set is used to control the headlamps, and the other is for the marker lamps. This arrangement lets both headlamps and marker lamps come on when the relay is energized but keeps the two lamp circuits isolated from each other when the relay is not energized. This allows the marker lamps to be turned on (for parking) without the headlamps coming on as well.

In my Chevette, two self-resetting circuit breakers were used, one for each lamp circuit. In the event of a momentary short circuit in the headlamps circuit, the markers remain on, offering a degree of safety. Fuses would be a poor choice here because, when blown, they would require physical replacement.

Keep in mind that different manufacturers use different charging circuits in their automobiles. However, if your car is equipped with an "idiot light" as described, it should be fairly simple for you to install the relay.

Figure 2 shows the schematic diagram of a circuit that can be found in some older General Motors cars. The regulator is externally mounted and may be either electromechanical or solid-state in design. In either case, the indicator lamp will be connected

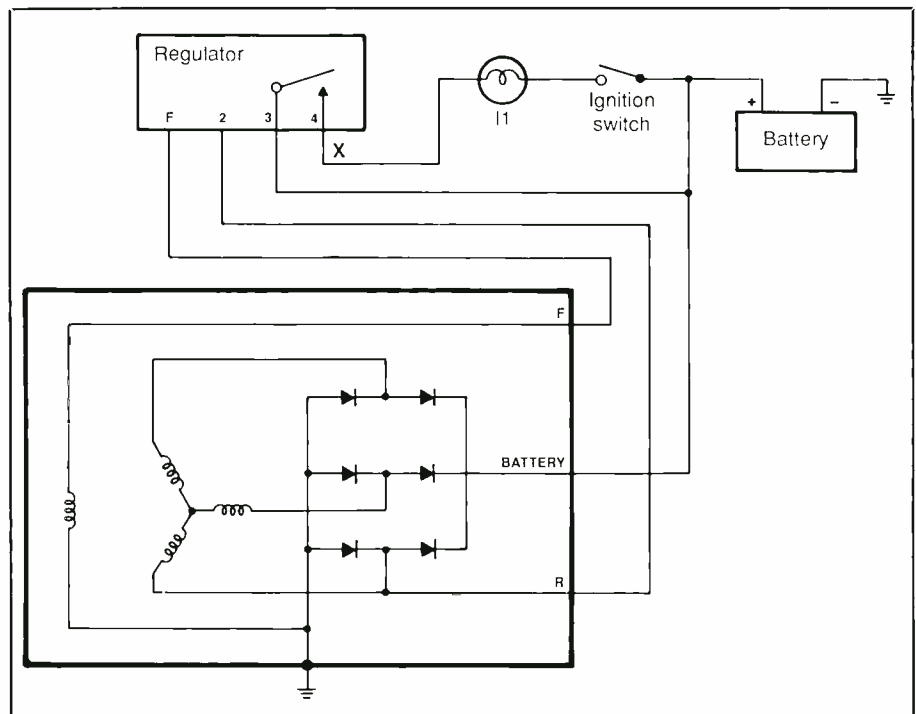

Fig. 2. Schematic diagram of circuit found in some older General Motors cars.

to a relay contact with the regulator. Terminal R of the alternator energizes the coil of the relay whenever the alternator is producing current. The headlamp relay of this project connects to regulator Terminal 4.

Figure 3(A) is the schematic diagram of a typical Ford circuit. Except for terminal markings, it employs much the same design as the General Motors circuit discussed above. The lamp is connected to Terminal 1, which is where the headlights control relay should be connected as well.

Shown in Fig. 3(B) is the schematic diagram of a similar circuit to that shown in Fig. 3(A). The difference here is that the Fig. 3(B) circuit uses an ammeter movement in place of the lamp. In this configuration, Terminal 1 is not used and, thus, is not suitable for the headlights-controlling relay. The STA (stator) terminal of the alternator is not connected to the regulator. It may not be used, or it may be connected to an electric-choke heater. The headlights relay could be connected to the STA terminal in this arrangement.

Some American Motors cars use a Motorola alternator, as shown in Fig. 4, that uses isolation diodes. In this arrangement, the lamp is connected between these diodes and the usual rectifier diodes. This is the point to which the lamp is connected and is shared by the headlights-controlling relay. The characteristic common to these circuits is that if an "idiot light" is used to indicate alternator function, the point that sinks current for the lamp can also "source" current for a relay.

Shown in Fig. 5 is the schematic diagram of a circuit used in Toyota cars. I used this circuit for experimenting. The alternator and regulator are mounted on a circuit board and driven by a variable-speed air motor. The neutral point of the stator windings is brought out to Terminal N and controls the regulator. When the experiments were finished, the air motor was replaced with a 1-horsepower electric motor, and the whole thing is now being used as a battery charger.

Shown in Fig. 6 is the schematic di-

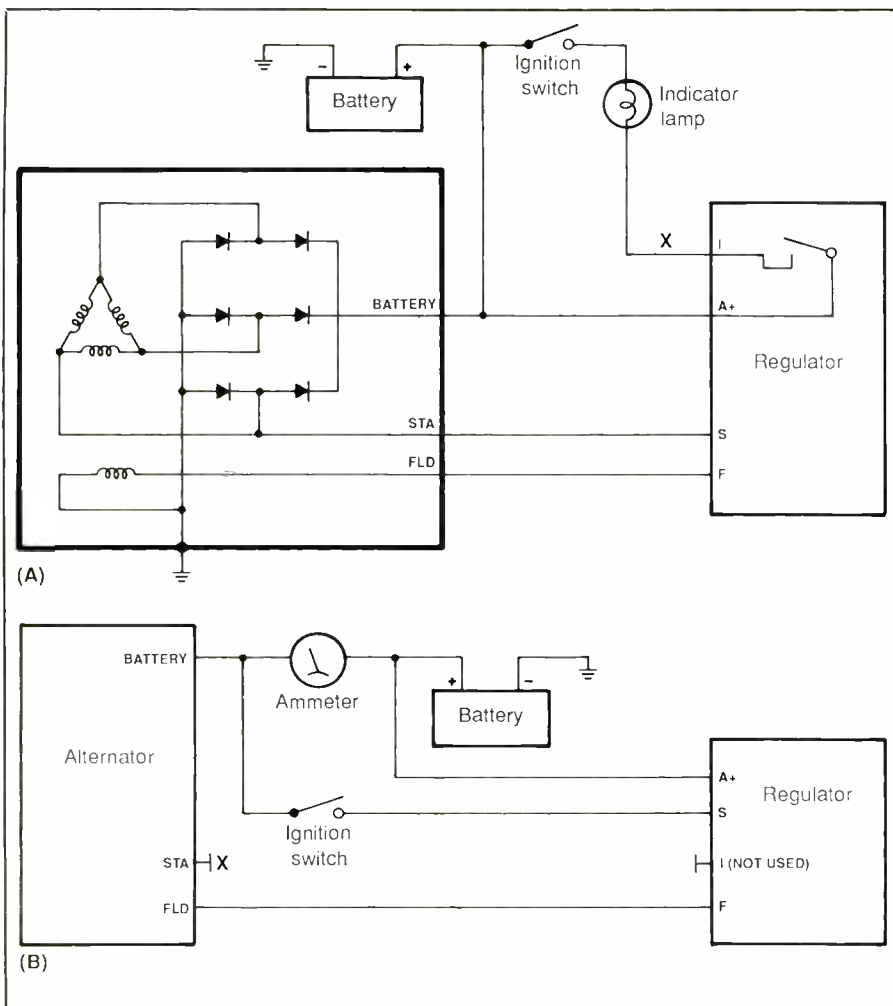

Fig. 3. Schematic diagrams of circuits that can be found in many Ford Motor cars: (A) with "idiot lamp" and (B) with ammeter charging indicators.

agram of a generator circuit that can be found in some older model automobiles. The output of the generator is fed to the battery through the cut-out relay inside the regulator. This relay closes when generator voltage is greater than battery voltage. Should the generator's output fall to less than the battery voltage, this relay opens. This prevents current flow from the battery to the generator. The output terminal of the generator can be used to power the relay that controls the headlamps.

Figure 7 is the schematic diagram of the complete Automatic Headlamps Circuit. As you can readily see, this is a very simple circuit de-

sign. Here, the relay feeds the headlamp circuit at the point between the headlamp and dimmer switches.

Five conductors connect the project to your vehicle's electrical system. The two circuit breakers go to one side of each contact pair of the relay. The other sides of the circuit breakers tie together and go to any point that is always at +12 volts in the vehicle's electrical system. The best place to make the +12-volt connection is to the positive (+) terminal of the battery, as shown.

The opposite sides of the contact pairs of the relay go to the line between the Ignition Switch and Marker lights and between the Igni-

tion and Dimmer Switches. One end of the relay coil connects to point "X" in your vehicle's charging circuit. Finally, the remaining line goes between the ground end of the relay coil and vehicle chassis ground, with the DISABLE SWITCH between these two points. The DISABLE SWITCH allows you to defeat automatic controller action if desired for any reason.

### Construction

As you can see from Fig. 7, there is very little "construction" for this project. All you need other than the relay, circuit breakers and switch are a small utility box and a metal bracket.

Machine the box by drilling holes to mount the relay and two circuit breakers, to permit exit of the five conductors that tie into the vehicle's electrical system and to secure a plastic cable clamp for the conductors into place near the entry hole. Also drill two small holes through the floor of the box to permit the project to be mounted in place inside the engine well. If you are using an all-metal utility box, deburr all holes and line the exit hole for the conductors with a rubber grommet.

Determine where in the engine compartment of your car the utility box will be mounted. Set the box in place and mark the locations of its mounting holes on the surface of the vehicle. Drill a small hole at each marked location. Then start a No. 6 or No. 8 sheet-metal screw into each hole. Remove the screws and loosely mount the box in place.

Use only No. 14 stranded insulated wire for all conductors in this project. Now determine how long each conductor must be to bridge from the utility box to the various points in the vehicle's electrical system and cut each to length, leaving 6 to 8 inches of slack for each. Note that three conductors go from the utility box to the vehicle's + battery terminal, the point identified with an "X" in the

ignition system and the marker lights conductor. The other two conductors go to the under-dash-mounted DISABLE SWITCH and line conductor that bridges the Ignition and Dimmer switches inside the passenger compartment.

Strip  $\frac{1}{4}$  to  $\frac{3}{8}$  inch of insulation from both ends of each conductor. Tightly twist together the fine wires at all ends and sparingly tin with solder. Route one end of all conductors into the box through the grommet-lined hole and secure a plastic cable clamp to all five conductors about 5 inches from the end *inside* the box. Pull the cable clamp very tight to assure that the conductors will not pull loose from inside the box. Crimp and solder the ends of each of two conductors to one side of each relay contact pair. Then crimp and solder the ends of each of two more conductors to the coil lugs of the relay.

Strip  $\frac{1}{4}$  to  $\frac{3}{8}$  inch of insulation from both ends of three 3-inch-long No. 14 stranded insulated conductors. Again, tightly twist together the fine wires at all ends and sparingly tin with solder. Mount the relay and circuit breaker in place inside the box, using suitable machine hardware and outside-tooth lockwashers between screw head and box and between component mounting lug and nut. Secure the plastic cable clamp in place via its mounting hole with No. 6 or No. 4  $\times \frac{3}{8}$ -inch machine hardware and an outside-tooth lockwasher between nut and box.

Now crimp and solder two of the 3-inch conductors to the remaining contact lugs of the relay. Crimp and solder the other ends of these conductors to one lug on each circuit breaker. Crimp one end of the remaining conductor to the remaining lug of either circuit breaker and solder the connection. Then crimp and solder the free end of this conductor and the remaining conductor that exits the box to the remaining lug of the other circuit breaker.

Place a flat washer on each of two

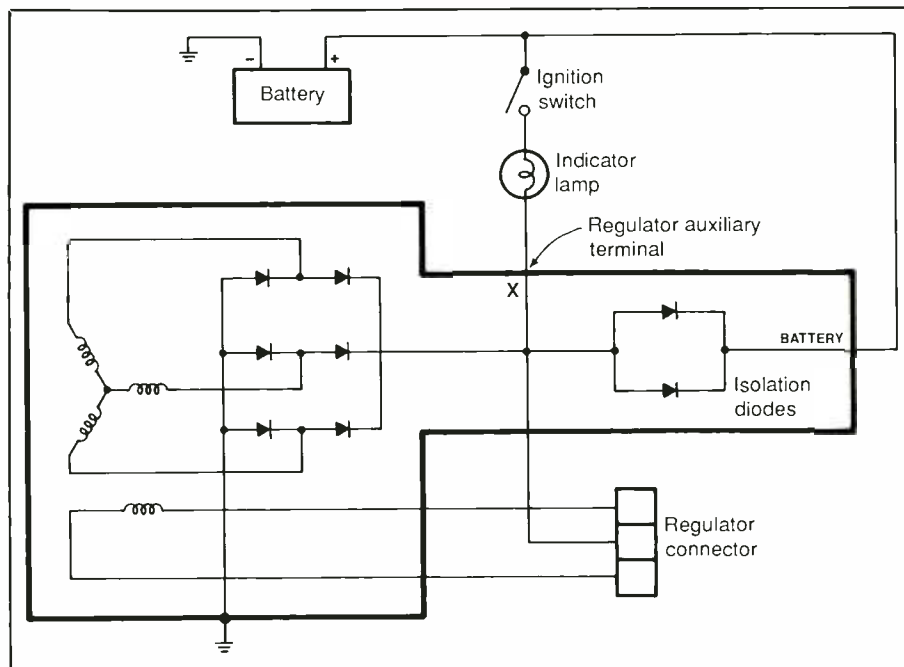

Fig. 4. Details of charging circuits used in American Motors cars.

No. 6 or No. 8  $\times \frac{1}{2}$ -inch sheet-metal screws and start a small rubber grommet onto each screw. Plug the screw ends into the holes in the floor of the box from the inside, and start another small rubber grommet onto the

protruding ends. Mount the box in its selected location via the screws. Tighten the screws only enough to slightly compress the rubber grommets; do not make them so tight that the box is very rigidly mounted.

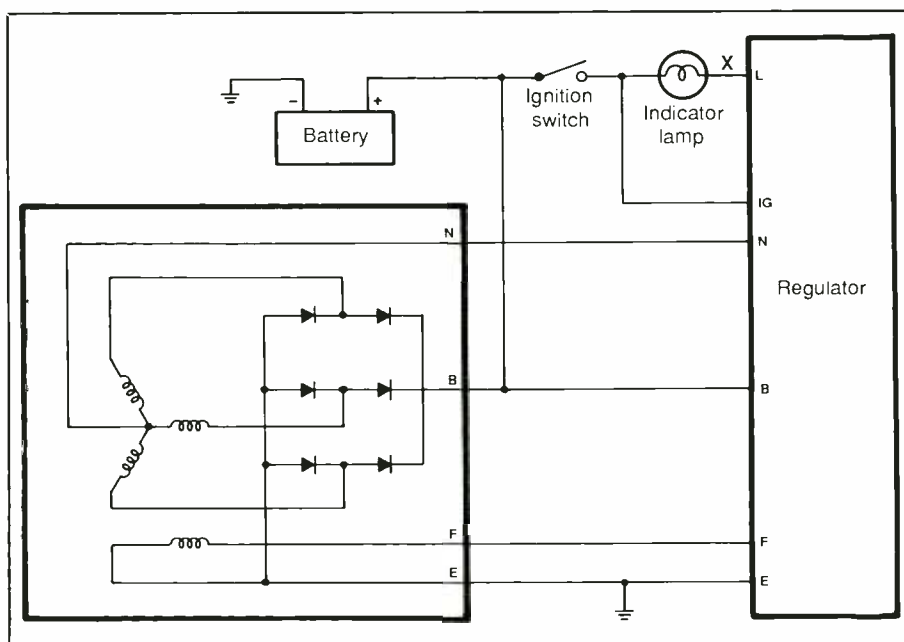

Fig. 5. Schematic diagram of circuit used in Toyota cars.



## Automatic Headlights Circuit

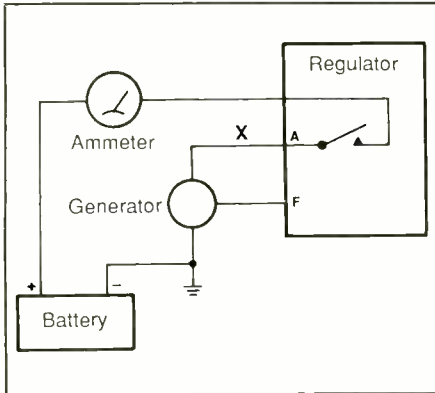

Fig. 6. Schematic diagram of generator circuit in some older model cars.

Before closing up the box, identify the destination of each conductor exiting it. If you did not use color-coded wire for the conductors, use an ohmmeter or signal tracer to make sure that the destination of each conductor is properly identified.

Route the two conductors that go inside the passenger compartment to their respective locations. Connect and solder the DIMMER SWITCH wire to the appropriate lug on the dimmer or headlights switch. If access to these switches presents a difficulty, cut into the existing conductor that bridges them and make the connection there. After cutting the conductor, strip  $\frac{1}{2}$  inch of insulation from both cut ends. Tightly twist together the fine wires in both cases. Slide onto one conductor a 2-inch length of heat-shrinkable tubing. Tightly twist together (use an axial twist, rather than parallel one) the stripped ends of the conductor and solder the connection. Now wrap the end of the DIMMER SWITCH wire around the connection and solder the three-way connection. Make certain that this connection is both electrically and mechanically sound. Slide the heat-shrinkable tubing along the conductor, center it over the connection and shrink it into place.

Mount a small switch bracket under the dashboard where it will be easily accessible but will not interfere

with the driver or front-seat passenger. Crimp and solder the DISABLE SWITCH conductor to one lug of the switch. Strip  $\frac{1}{4}$  to  $\frac{3}{8}$  inch of insulation from both ends of a suitable length of No. 14 stranded wire. Twist together the fine wires at both ends and sparingly tin with solder. Crimp and solder one end of this wire to the other lug of the switch and terminate the other end in a spade or ring lug. Mount the switch on the bracket with the hardware provided with it.

Terminate the free end of the loose wire connected to the switch at any convenient point on the vehicle that is at electrical ground. This can be an existing screw or a new screw for which you must drill a hole. Whichever the case, burnish the mounting location down to bright metal with fine emery cloth. Then secure the conductor in place with a sheet-metal screw with an outside-tooth lockwasher between spade or ring lug and metal chassis.

Return to the engine compartment

and connect the free end of the "X" conductor to the appropriate point in the vehicle's charging system. If the wire already connected to that point has a spade or ring lug on it, terminate the project's conductor in the same type of lug. Otherwise, crimp

### PARTS LIST

- CB1, CB2—20-ampere, self-resetting automotive circuit breaker
- K1—12-volt dc dpdt relay with 10-ampere or more contacts and socket (see text)
- S1—Spst heavy-duty (10-ampere or more) toggle switch
- Misc.—Suitable enclosure (see text); bracket for S1 (see text); rubber grommets; heat-shrinkable tubing; spade or ring lugs; plastic cable clamp; heat-shrinkable tubing;  $\frac{1}{2}$ -inch No. 6 or No. 8 sheet-metal screws; machine hardware; external-tooth lockwashers; No. 14 insulated stranded wire; solder; etc.

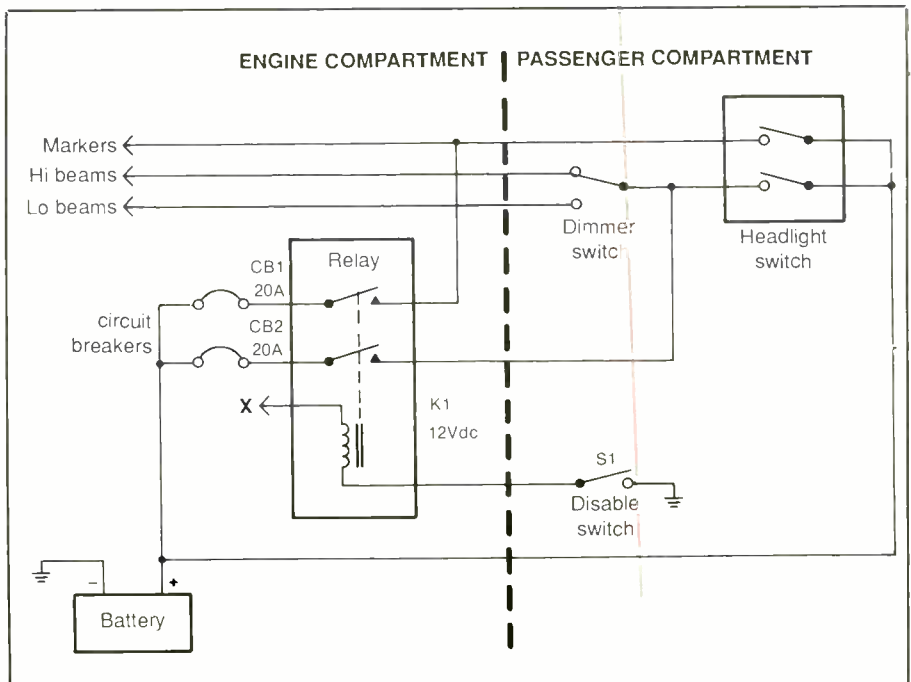

Fig. 7. Complete schematic diagram of the Automatic Headlights Circuit. It consists entirely of a 12-volt dc relay, two 20-ampere self-resetting circuit breakers, a single-pole, single-throw toggle switch and No. 14 insulated stranded wire.

and solder the end of the conductor to the connection point.

Terminate the free end of the circuit-breaker conductor at the battery's + terminal. This can be done by soldering the free end of the conductor to the appropriate battery cable clamp. Finally, connect and solder the free end of the remaining project conductor to the markers light conductor in the same manner described above for the in-line ignition/dimmer switch connection.

While researching this article, I had some difficulty locating detailed information on Chrysler Motors products. It would appear that Chrysler cars always use ammeters instead of "idiot lights," which means that there is no place to connect the relay. It should be possible to open the alternator and attach a wire to one of the stator terminals and bring this wire out to the relay. However, I have not actually tried this. If you have a Chrysler vehicle, check with your dealer to find out if such a connection is possible.

Another alternative with Chrysler cars is to use the circuit published in Mr. Wright's article that appeared in the October 1988 issue of *Modern Electronics*—with some changes. That circuit does not show any connection for the marker lamps, so use a double-pole relay instead of the one specified. Eliminate the fuse in the battery-feed to Terminal A and replace it with circuit breakers in series with each set of relay contacts. Also, instead of routing the headlamp circuit through two sets of relay contacts, wire the contacts of K2 in series with the coil of K1, rather than to the contacts of K1. This arrangement allows K2 to be a lighter-duty relay, similar to K3.

If your particular situation requires driving the relay from the alternator R, N or STAT terminal, it is a good idea to check the voltage at that point before selecting your relay. Some alternators use the neutral point of a wye-connected stator (see

Fig. 5). This will produce only half the output voltage, which will be 6 volts in a 12-volt system. Consequently, you need a 6-volt dc relay instead of the 12-volt one specified in the Parts List.

I used a Potter & Brumfield No. KRP11DG 12-volt dc relay in my installation, mainly because I had it on hand. It would have been a good choice in any event. In experiments I performed on this relay using a variable dc power supply, I determined that it energizes at potentials as low as 7 volts but it does not drop out until the feed drops to about 2.8 volts. This hysteresis is good because it means that, once energized, the relay will hold solidly closed even if the engine slows almost to a stall.

While the P&B relay is a good choice for this application, it is fairly expensive. Relay and socket cost about \$25. Radio Shack has a similar relay and socket at a much lower price, but the socket will require that you use some sort of mounting bracket. Whatever relay you choose, make certain that each set of its contacts can handle a 10-ampere load.

### In Closing

While I was using this retrofit modification this past winter, I noted an unexpected cold-weather benefit. On cold mornings, I like to start my car's engine and let it run a while before leaving for work. It used to be difficult to tell if the engine had stalled, but now all I have to do is look out the window to see if the headlights are on. If they are, the engine is running and all is well. Also, should the engine stall without my knowing it, at least the headlights will extinguish and not drain the battery.

My car is long past any warranty; so installation of this modification was of concern only to me. If you plan on installing this project in your in-warranty car, check with your dealer to find out if it will void your protection.

ME

## AMAZING SCIENTIFIC & ELECTRONIC PRODUCTS

**PLANS**—Build Yourself—All Parts Available In Stock

- LC7—BURNING CUTTING CO. LASER \$20.00
- RUB4—PORTABLE LASER RAY PISTOL 20.00
- TCC7—3 SEPARATE TESLA COIL  
PLANS TO 1.5 MEV. 25.00
- IOG2—ION RAY GUN 10.00
- GRAT—GRAVITY GENERATOR 10.00
- EML1—ELECTRO MAGNET COIL GUN/LAUNCHER 8.00

**KITS**

- MFT3K—FM VOICE TRANSMITTER 3 MI RANGE 59.50
- VVPM7K—TELEPHONE TRANSMITTER 3 MI RANGE 49.50
- BTC3K—250.00 VOLT 10-14" SPARK TESLA COIL 249.50
- LHC2K—SIMULATED MULTICOLOR LASER 44.50
- BLS1K—100.00 WATT BLASTER DEFENSE DEVICE 69.50
- NIG7K—NEGATIVE ION GENERATOR KIT 34.50
- STAIK—ALL NEW SPACE AGE ACTIVE  
PLASMA SABER 59.50
- PG5K—PLASMA LIGHTNING GLOBE KIT 49.50
- SDSK—SEE IN THE DARK VIEWER KIT 199.50

**ASSEMBLED**

- PTW1K—SPECIAL EFFECT VISUAL PLASMA  
GENERATOR FOR GLOBES/NEON TUBING ETC. 59.50
- BTC10—50.000 VOLT—WORLD'S SMALLEST  
TESLA COIL 54.50
- LGU40—1MW HeNe VISIBLE RED LASER GUN 249.50
- TAT30 AUTO TELEPHONE RECORDING DEVICE 24.50
- ITM10—100.000 VOLT 20" AFFECTIVE RANGE  
INTIMIDATOR 99.50
- LIST10—SNOOPER PHONE INFINITY  
TRANSMITTER 169.50
- IPG70—INVISIBLE PAIN FIELD GENERATOR—  
MULTI MODE 74.50

• CATALOG CONTAINING DESCRIPTIONS OF ABOVE PLUS HUNDREDS MORE AVAILABLE FOR \$1.00 OR INCLUDED FREE WITH ALL ABOVE ORDERS.

PLEASE INCLUDE \$3.00 PH ON ALL KITS AND PRODUCTS PLANS ARE POSTAGE PAID SEND CHECK, MO, VISA, MC IN US FUNDS

**INFORMATION UNLIMITED**  
P.O. Box 716, DEPT. ME, AMHERST, NH 03031

CIRCLE NO. 45 ON FREE INFORMATION CARD

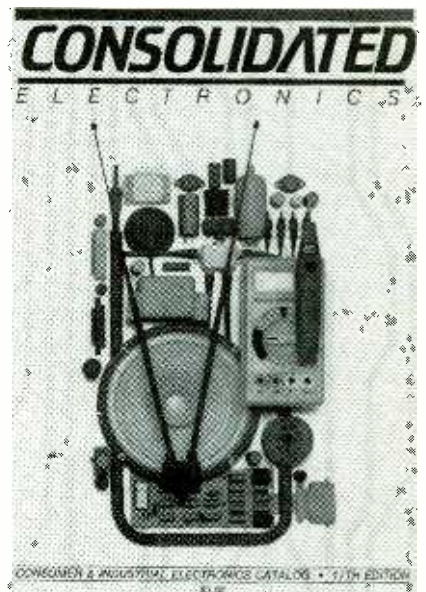

## GET THE ULTIMATE ELECTRONICS CATALOG.

Order your 260 page catalogue packed with over 10,000 money saving electronic parts and equipment. Send \$3.00 check or money order, or call 1-800-543-3568 today and use your Mastercard or Visa  
Consolidated Electronics, Incorporated  
705 Watervliet Ave., Dayton, Ohio 45420-2599

NAME \_\_\_\_\_  
ADDRESS \_\_\_\_\_  
CITY \_\_\_\_\_  
STATE \_\_\_\_\_ ZIP \_\_\_\_\_

CIRCLE 71 ON FREE INFORMATION CARD





## PRODUCT EVALUATION

### *DynaBook—A self-contained, portable CD-ROM reader*

By John McCormick

The original DynaBook was first described by Alan Kay, at that time a researcher at Xerox PARC (Palo Alto Research Center). His vision was of a handheld keyless data display device linked to the world's libraries/databases via radio links. Today, such a device is entirely feasible, except that a worldwide network of data is not available.

The closest we can now come to the original DynaBook concept is to link a portable computer with a cellular phone and access MEADE or DIALOG. Alternatively, a product called the DynaBook that's now ready to be marketed by Scenario Inc., Somerville, MA, has most of the originally conceived elements.

This new DynaBook utilizes CD-ROMs—4.7" compact discs with 552-megabyte capacity—as the reference data source instead of a telecommunications database. It includes both a half-height Hitachi CD-ROM player and a fully functional 80286 CPU, 3.5" 720K floppy-based portable computer, and a touch screen that substitutes for a keyboard. Moreover, its \$4,995 price is below that of equally powerful portable computers such as the Compaq SLT/286 laptop (before adding \$650 for Dynabook's optional hard disk). Additionally, it incorporates a digital-to-analog converter for ac-

cessing hi-fi or digital sound, along with a two-channel headphone jack and volume control; a keyboard port for using it as a 286-compatible PC; MS-DOS 3.21 built into ROM; parallel and serial ports; an external video port for plugging in another video monitor (mono or RGB); and a daisy-chain port for adding up to three CD drives. It also has Hercules and CGA video display modes.

The nearly \$5,000 price tag is higher than that of many other hard-disk 286 laptops, but only the DynaBook and the SLT have the latest VGA quality back-lit supertwist LCD screen with a black-on-white display, a vast improvement over older displays.

The new device is said to be the lightest stand-alone CD-ROM reader available, weighing only 16 lbs. Its compact dimensions are 14" × 14.5" × 2.9". The display can be detached from its base, connected by a coiled line cord, and positioned much like a book for comfortable reading. Its viewing area is 10.2" × 5.8".

The first time I saw the DynaBook, I got to spend about one hour with it. I found the technology fascinating, but I couldn't be certain that the excitement wasn't just due to its novelty. My much longer test evaluation only confirmed the powerful capabilities of this marriage of technological advances. The DynaBook is an important delivery platform

for everything from maintenance manuals and cartographic maps to databases that include photographs.

#### *Display*

An innovative feature of DynaBook is the latest touch-screen technology, which, unlike other touch-screens, can be highly scratch-resistant. This screen's action is based on a standing sonic wave touching the underside of whatever material is used for the screen. In the case of the DynaBook, it is just optical-quality glass. Pressing your finger, not fingernail or pen (because they don't seem to work, not because the screen is sensitive to scratches), very lightly against the screen sends a signal to the computer.

Resolution of this screen is 25 dots/inch on both the X and Y axes. Amazingly, there are 15 levels of sensitivity in the Z or pressure axis. This last fact means that, not only can you select items using the X-Y resolution, you can also (with appropriate programming) adjust that response by the pressure with which you press the screen.

In the demo package, a piano keyboard is included that operates like an organ; the longer you press the keys, the longer the tone is sustained. Practical applications for this would include moving through 3-D architectural displays, acti-



vating hypertext information by pressing words, moving the point of view through complex electronic or machinery diagrams and even activating help by pressing a command key (image) harder.

The screen must be calibrated. On the test unit, I did this every time the computer was powered up, but the calibration data can also be stored for automatic loading.

I didn't bother with this for two reasons; first, the setup and calibration takes only a few seconds and is accomplished by touching three crosses displayed on the screen, but mostly because the software needed to modify the CONFIG.SYS and AUTOEXEC.BAT files in the ROM-based "A" drive wasn't available at the time I was reviewing the product.

### Optional Keyboard

You can also plug a standard computer keyboard into the DynaBook for programming or other operations that are simpler to do with a real keyboard (remember, this is a full 80286-based MS-DOS compatible computer).

However, there is a touch-screen keyboard included in the demo which, according to Judy Bolger, Vice President of Scenario, will be capable of operating the entire system when you don't have a keyboard handy.

The keyboard socket is for standard PS/2 enhanced keyboard, but an adapter plug was included for other AT-style keyboards. I actually used the one that came with the latest Dell Computing Model 325 (25-MHz 80386).

### Demo

A very impressive demo package is included with the DynaBook; at least the preliminary version I saw.

Among the various interactive programs was an on-screen keyboard that played notes when you depressed the keys. What was remarkable about this was that, not only did the keys move when you pressed them, pressing harder caused the note to be sustained longer even after releasing pressure, something you could only accomplish with a touch-screen that features different levels of pressure sensitivity.

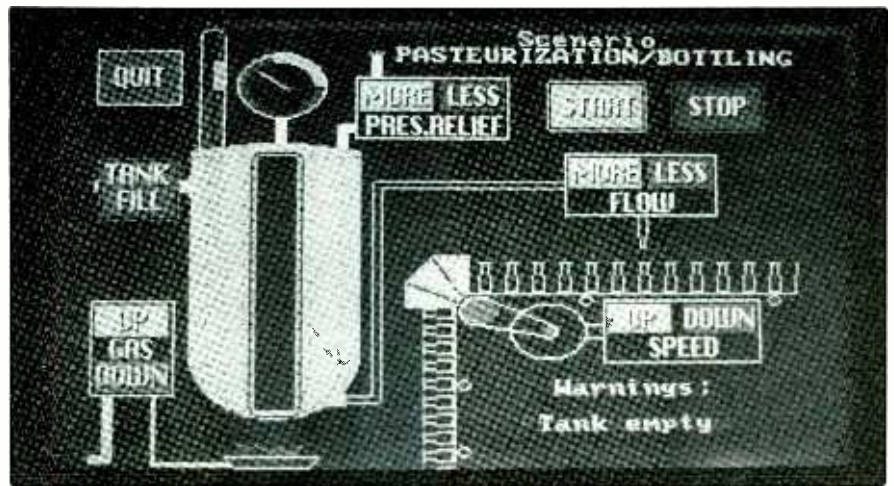

Screen shot of bottling plant simulation.

A simple maze lets you trace paths through the hedges, using your finger on the screen. A touch-tone dialer, simulation of an automated teller machine, and a paint program rounded out the more simple demonstrations.

A very fine demo was the showing of a bottling plant with boiler, speed, and fill controls. The controls have to be constantly adjusted (by touching them) to keep the bottles filled to the top (but without overflowing) and also prevent the boiler from running dry.

Also included was a fire control computer that lets you select from a list of assigned targets, adjustments for wind and

other factors, and a gun for firing. This is not a game machine, though, so you don't get to see the explosion.

### In Use

I can't comment on any documentation that may come with the final product because the material with my very-preliminary package was not the version that will be supplied with the machine. However, operation was certainly simple enough and the usual trouble with installation of MSCDEX (the program needed to use a CD-ROM drive with an MS-DOS computer) didn't come into play because all

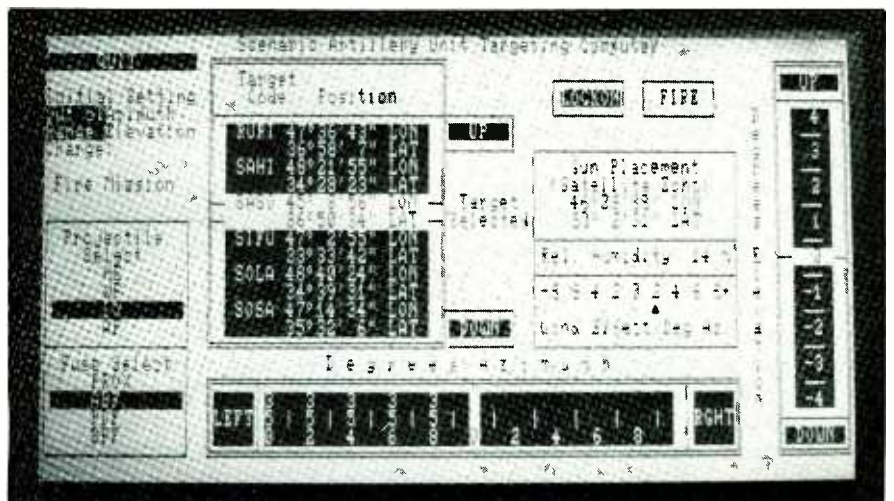

The fire-control computer.

# PRODUCT EVALUATION...

the configurations were already burned into ROM. In fact, the DynaBook is so easy to operate that I had hooked it up and ran it through its paces, including removing the Springsteen CD and replacing it with Vivaldi's *Four Seasons*, before I ran across the documentation and note that Scenario had included.

My sample machine was mainly intended to go to developers who will integrate their CD-ROM publications with the touch screen and the DynaBook's computation capabilities. I presume that any final production machines would have a simple introduction to the operation of the DynaBook and a more extensive user's manual produced by the VAR or integrator selling the complete DynaBook/data package.

## 286 Power

The 10-MHz 80286 computer that makes up one of the three main parts of the DynaBook (along with the CD-ROM player and the touch-display) is a full-featured computer, assuming one adds the optional 20-MB hard drive.

The back panel of the unit has 9-pin serial and 25-pin parallel ports, as well as a 40-pin CD-ROM drive daisy-chain port and a 9-pin female video outlet. There is also a slide switch on this back panel that reverses the screen for easier viewing, an action that is sometimes implemented from a keyboard in other laptops.

Viewing the DynaBook just as a computer, a major difference between this and other similarly powerful laptop computers is the lack of a keyboard. It's replaced by the extra 25-pin cable socket on the side that connects to a flexible six-foot coiled cable that carries signals between display/control panel and the main computer.

The system's lap-size touch screen has remarkably clear text and a graphics capability that is able to even display photographs well.

Except for the screen cable, which is normally removed completely (but could remain in place), the Dynabook forms a solid one-piece unit during transport. In use, the main unit can be placed on a desk or on the floor. The control screen can be held in the lap or placed on a desk up to six feet away using the included cable. Alternatively, the folding bracket on the

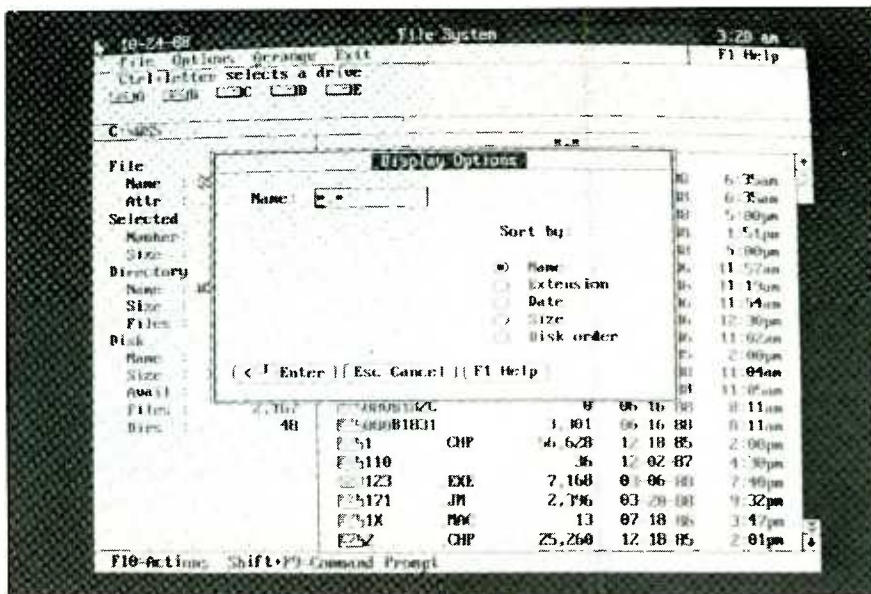

Screen short of DynaBook in its "computer" mode.

back of the display screen can be used to hold the screen at a convenient angle, either on a desk or on the back of the DynaBook itself (I arbitrarily chose to call the part of the DynaBook with the floppy drive opening the front, though the screen can face in any direction).

The connecting cable is a bit stiff, but not difficult to use. Considering the amount of information to be passed back and forth and the FCC requirements for shielding, the cable is remarkably light. Although the manufacturer used six feet as about the upper limit for cabling length to this screen, Scenario has been able to operate successfully with cables more than 20 feet long. However, such a cable alone weighs more than the complete DynaBook.

There are intensity and contrast slide switches on the screen, but to reverse the image you must reach the main unit; otherwise, you should be able to control the entire operation of the DynaBook right from that handy screen.

The sensitivity and accuracy of the touch-screen were remarkable, almost enabling me to touch-type on the screen-displayed keyboard. The most intriguing, but possibly least important, demonstration of the touch-screen was the simple "paint" software where you can draw right on the screen with your finger.

## Conclusions

The DynaBook is the first of a new breed of devices. Thus, it is certainly possible to become too enthusiastic about its potential while ignoring shortcomings. Even when the inevitable competitors come on the market, however, I think we will look back at the Scenario product as being a significant advance.

The only important problem I can now see with this machine is probably beyond the ability of anyone to remedy at the present time—the need for a powerful battery unit.

I have only operated the DynaBook from line current through its external power supply, but it actually runs on 12 volts dc. Thus, it is perfectly capable of operating from a car's cigarette lighter or a portable battery pack of the type used to power video cameras and their lamps.

At 16 pounds, the Dynabook is a bit hefty, but not unreasonably so, since portable computers like the Compaq 386 Portable weigh in at over 20 pounds even without a CD-ROM drive. Adding a portable power supply will be a problem, but only because of the weight, not for any technical reasons. Scenario is now evaluating various configurations before se-

*(Continued on page 82)*



## Experimenting With the Piezoelectric Effect

By Forrest M. Mims III

**Piezoelectric material** has the ability to transform mechanical movement into a voltage. The effect works both ways, for a piezoelectric material will generate a voltage when it is bent, stretched or compressed. This is the first of two in-depth columns that will deal with piezoelectricity. In this installment, I'll cover applications for piezoelectricity and various kinds of piezoelectric materials, following which we'll experiment with a piezoelectric fan and some high-voltage piezoelectric generators.

### Applications

Piezoelectric devices have become one of the most important and diversified classes of electronic components. If this claim seems to be somewhat exaggerated in this age of silicon microchips, just look around you. Chances are, your life is very much influenced by piezoelectricity.

You're probably very much aware of most or all the applications for piezoelectronics I am about to list. But you may never have seen so many of these applications described in one space.

Let's start with the watch on your wrist. If it is battery powered and digital, its time base is a piezoelectric quartz crystal that oscillates at a frequency of 32,768 Hz ( $2^{15}$  Hz). If your watch has an alarm function, the sound you hear from it at the preset time is almost certainly generated by a piezoelectric ceramic wafer. Similar sound generators are installed in microwave ovens, alarm clocks, fever thermometers, telephones, paging receivers and computers. They are also frequently used in electronics-assisted photographic and all-electronic video cameras, timers and fire/smoke and intruder alarms.

Speaking of smoke alarms, piezoelectric trip hammers provide ignition sparks for gas heaters, cigarette lighters, outdoor gas-type cooking grills and gas lanterns. Some gasoline engines incorporate a piezoelectric element in place of an ignition coil. The element produces a spark each time it is struck by a rotating cam.

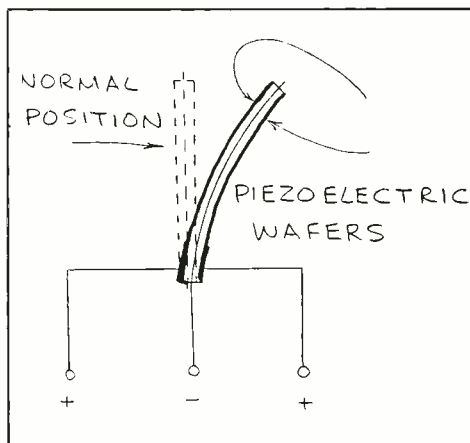

Fig. 1. Piezoelectric bimorph bender.

The color in your TV receiver is regulated by a quartz crystal that oscillates at a frequency of 3,579,545 Hz (commonly abbreviated to 3.58 MHz). Other piezoelectric devices filter the signal in your FM radio, faithfully transform the high-frequency audio signals from your receiver into sound, control the frequency of your CB rig and generate the timing

signals in your personal computer. Other applications of piezoelectric devices include microphone elements, motors, switches and many kinds of sensors that are capable of detecting heat, sound, liquid levels and pressures.

Piezoelectric crystals provide accurate timing for household appliances like clothes dryers and microwave ovens. Piezoelectric wafers vibrating at ultrasonic frequencies permit boaters and fishermen to accurately monitor bottom conditions and find fish. Thanks to a related technology, several years ago, my wife and I were able to view our third child four months before she was born.

The ultrasonic waves produced by wafers of piezoelectric ceramic can be so intense that they can violently agitate a fluid in which they are immersed. It is this principle that makes possible ultrasonic humidifiers and jewelry cleaners. The ultrasonic waves produced in this fashion can be exceptionally energetic. Indeed, a piece of wood can be ignited by pressing it against a ceramic plate that is intensely vibrating at ultrasonic frequencies.

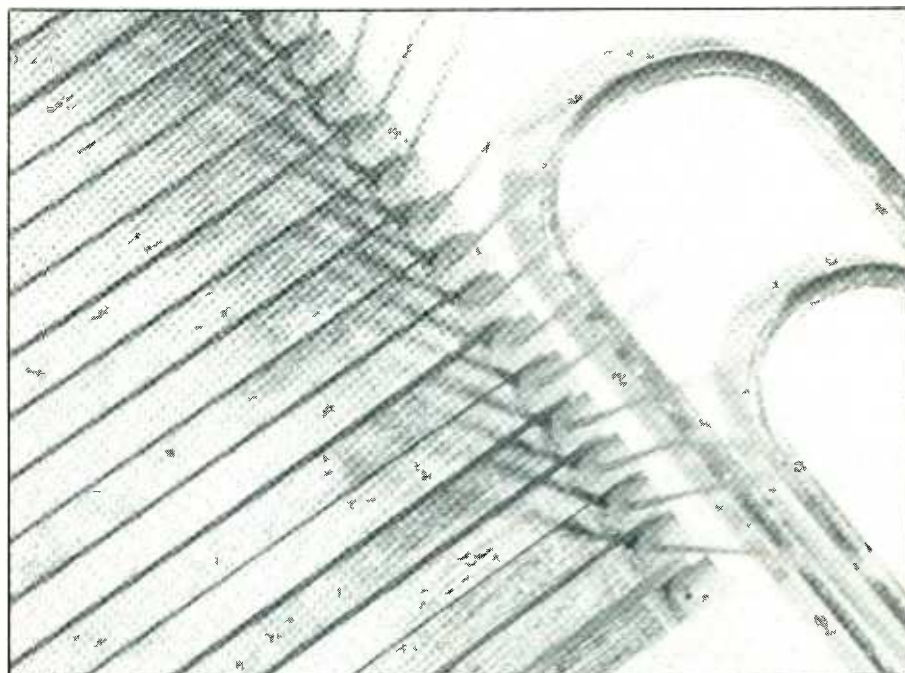

Fig. 2. Bimorphs used as a tactile stimulator in a reading machine for the blind.



These are only some of the most common examples of piezoelectricity applications. There are literally hundreds of applications for the dozens of different kinds of piezoelectric devices that are now available.

## Early Uses of the Piezoelectric Effect

All the applications for piezoelectronics listed above can be traced to a discovery made by Pierre and Paul-Jacques Curie more than a century ago. In 1880, the two brothers discovered that many different crystals produce a voltage spike when a weight was placed on them. The next year, they discovered that applying a voltage to a crystal caused the crystal to lengthen. They named these phenomena the "piezoelectric effect" after the Greek word "piezien," which means to press.

The first major use of the piezoelectric effect was in detection of submarines during World War I. It was later discovered that piezoelectric quartz crystals can be used to precisely regulate the frequency of radio transmitters. Tens of millions of quartz crystals were produced by the United States for use in military radios during World War II.

Quartz remains the most important piezoelectric crystal. Quartz crystals, of course, are still widely used to keep both radio transmitters and radio receivers properly tuned. An important advantage of quartz is that it is relatively insensitive to changes in temperature. This is why you can take a hand-held transceiver out on a frigid night and maintain contact with a base station that is kept warm by a space heater.

Another important early application of quartz crystals that is still in widespread use is the filtering of electronic signals. In this application, quartz crystal filters are especially useful in various kinds of cable and radio communication system links.

Development of these and other early applications for piezoelectricity eventually led to the hundreds of piezoelectronic devices now in widespread use. Later, we'll experiment with a piezoelectric fan.

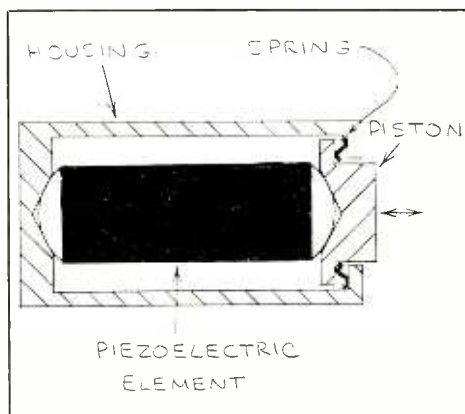

Fig. 3. Burleigh Instruments, Inc., piezoelectric pusher actuator.

First, however, let's examine some piezoelectric materials.

Many different naturally occurring and man-made crystals exhibit the piezoelectric effect. I've already noted that quartz is among the most efficient and important of piezoelectric materials. Quartz crystals are physically sturdy and, unlike some other piezoelectric materials, does not absorb water. These crystals are also relatively immune to changes in temperature. For applications in which even their limited response to temperature changes is unacceptable, quartz crystals can be warmed to a constant temperature by a miniature heater known as a "crystal oven."

The lack of a center of symmetry is what gives quartz and other crystals their piezoelectric properties. Rochelle salt crystals, which have no center of symmetry, are efficient piezoelectric materials that have been widely used in many applications, including phonograph pickups, microphones and earphones. Unfortunately, Rochelle salt crystals are fragile and sensitive to temperature changes. Other piezoelectric crystals include tourmaline, lithium niobate, lithium sulphate and ammonium dihydrogen phosphate.

After quartz, the most important piezoelectric materials are ceramics like barium titanate, zirconate titanate and lead zirconate-lead titanate. Ordinarily, these polycrystalline materials have no piezoelectric properties. During the manufac-

turing process, a strong electrical field aligns the crystallites within the material, thereby giving the material piezoelectric properties. This process is called "poling." Piezoelectric ceramics have many applications and are relatively inexpensive.

Certain plastics can also be given piezoelectric properties during their manufacture. Among the most important are polytrifluorethylene, polyvinyl chloride and polyvinylidene fluoride. The last polymer has by far the best piezoelectric properties. Like piezoelectric ceramics, piezoelectric plastic films have many practical applications. Moreover, they are inexpensive and flexible and can easily be cut to any desired shape.

## Piezoelectric Bimorphs

Mechanical movement of a thin plate or sheet of piezoelectric material in response to an applied voltage can be greatly increased by bonding it to a second plate or sheet. The resulting sandwich-like structure is known as a "bimorph."

Shown in Fig. 1 is a bimorph connected to a voltage source. When one end of the bimorph is held in a fixed position, the opposite end will bend away from its normal position when a voltage is applied. When the polarity of the applied voltage is reversed, the bimorph will bend in the opposite direction. The bimorph will also generate voltage when it is bent, with the polarity of the voltage depending on the direction of bend motion.

Bimorphs can be made from sandwiches of ceramic or plastic piezoelectric materials. Their many applications include stereo phonograph pickup cartridges, microphone elements, earphone elements and vibration sensors. Figure 2 shows an array of ceramic bimorphs that provide a tactile output for a reading machine for the blind. Vibration of the wires attached to the ends of each bimorph can be detected easily by a finger tip.

Bimorphs are mounted in either of two ways. End-supported bimorphs are provided with mounting supports at both ends. The center of the bimorph then becomes its flexible region. Cantilevered bimorphs are mounted at only one end such

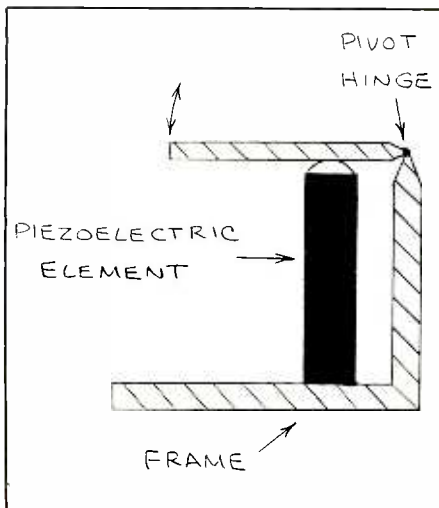

Fig. 4. Burleigh Instruments piezoelectric levered actuator.

that their free end becomes the flexible region.

Bimorphs are manufactured by several companies, including Vernitron Piezoelectric Division (232 Forbes Rd., Bedford, OH 44146-5478). I recently experimented with some bimorphs made by this company. When driven by an audio-frequency signal, a bimorph will produce an audible "buzz" or tone. The sound can be greatly amplified by taping the bimorph to an index card. At low drive frequencies, the vibration of the bimorphs I experimented with was very easily felt by a fingertip.

### Piezoelectric Actuators

Piezoelectric actuators are specifically designed to produce movement in response to a control voltage. Many different kinds of actuators are available. They can be made from bimorphs or stacks of piezoelectric disks.

Piezoelectric micropositioners are actuators that move various electronic and optical devices over very short distances. One common application for micropositioners is the precise movement of optical detectors and emitters through the focal region of a lens. Micropositioners are also used to precisely align optical fibers and microminiature optical components.

Operation of a common type of micropositioner relies on the fact that a properly poled ceramic disk will expand in thickness when a voltage is applied across it. Since a single disk might expand only a fraction of a micrometer, practical micropositioners are made by stacking many disks into a cylinder. Total available expansion of the length of the cylinder is the sum of the expansion of the individual disks from which it is formed. One such cylinder made by Burleigh Instruments, Inc. (Burleigh Park, Fishers, NY 14453) gives an expansion of about 5 micrometers per 100 applied volts.

Figure 4 shows a lever arrangement that provides more movement using the same kind of piezoelectric element. However, the movable arm greatly amplifies the element's movement. According to information supplied by Burleigh Instruments, the movement equals the extension of the element times the ratio of the length of the lever arm to the distance between the end of the element and the pivot hinge.

### "Worm Motors"

In recent years, various kinds of piezoelectric motors have been developed. Some are in commercial use. For example, some camcorders incorporate piezoelectric lens focusing motors.

The operation of one kind of piezoelectric motor resembles the motion of an inch worm. One such motor is appropriately named the Inchworm Motor™ and is made by Burleigh Instruments. It consists of three piezoelectric cylinders through which a movable shaft is passed. By applying a pattern of control voltages to each cylinder, the shaft can be made to move in either direction.

Shown in Fig. 5 is a diagram that illustrates how the motor is made and how it works. The two outermost piezoelectric cylinders squeeze against the shaft when they are actuated by an applied voltage. The center cylinder extends when it is actuated. Here is what occurs:

Initially, no voltage is applied. Outermost cylinders 1 and 3 are fully expanded and center cylinder 2 is not extended. A

voltage is then applied to cylinder 1 to hold the shaft in place. Next, a voltage is applied to cylinder 2 to extend the motor along the shaft. The voltage is then removed from cylinder 1 to unclamp the left end of the shaft. Then the voltage on cylinder 2 is removed to permit the cylinder to contract. Cylinder 1 is then clamped to hold the shaft in place and cylinder 3 is unclamped.

This sequence is repeated to move the shaft through the motor from right to left. A Burleigh Inchworm Motor gives a shaft movement of greater than 2 millimeters per second when the frequency of the clamping pulses is 800 Hz.

### Piezoelectric Fans

The "motor" for a piezoelectric fan is a ceramic or plastic bimorph bender that is driven by a sinusoidal voltage source. The fan doesn't have a rotating blade or blower as does a conventional fan. Ceramic fans move air by means of a vibrating sheet of Mylar that is bonded to one end of the bender. The entire length of a plastic bender vibrates. The result in ei-

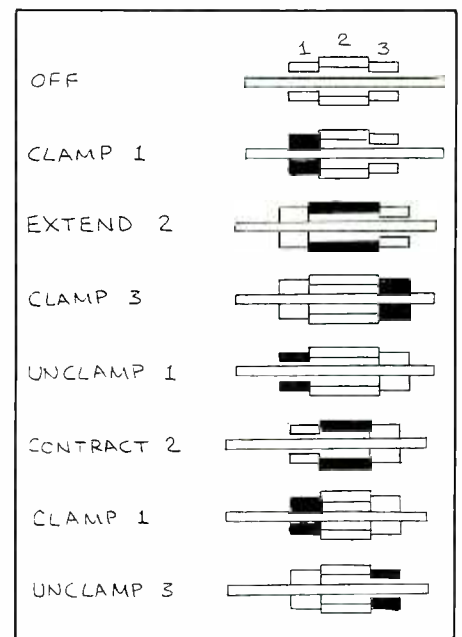

Fig. 5. Burleigh Instruments piezoelectric Inchworm Motor.

ther case is a device you have to see to believe.

Let's first consider the case of the bimorph bender. When a sinusoidal voltage is applied to the bimorph bender, one end of which is clamped in a fixed position, the free end of the bender vibrates. If the sinusoidal voltage has an audio frequency, you can hear the sound produced by the vibrating bender. While movement of the end of the bender is almost imperceptible to the human eye, you can easily feel the vibration by touching the end of the bender.

The length of the bender and any extension vane attached to it determines the resonant frequency of the assembly. When the frequency of the voltage applied to the bender matches the resonant frequency of bender and vane, the vane flaps rapidly back and forth. This motion, which resembles the movement of the tail of a fish, generates a turbulent vortex of air along and toward the end of the trailing side of the vane. When the vane reaches the end of its movement and begins to move in the opposite direction, the vortex of air flies off the end of the

vane. The rapid back-and-forth motion of the vane creates a series of vortices that merge into a stream of air.

While a single vane will move air, a much better approach is to use two closely spaced vanes. This doubles air movement and merges it into a reasonably directional stream.

Thus far, we have described ceramic benders with an extension vane. This discussion also applies to plastic benders. The only difference is that a plastic bimorph bender requires no extension vane. Unlike ceramic bimorph benders, plastic benders are flexible enough to flap back and forth on their own.

## Experimenting With a Piezoelectric Fan

Piezo Electric Products, Inc. (212 Durham Ave., Metuchen, NJ 08840) manufactures dual-vane piezoelectric fans. Shown in the photo in Fig. 6 is one of the company's fans. You can purchase individual Quadrature Fan Module B piezoelectric fans like the one shown from Edmund Scientific Co. (101 E. Gloucester Pike, Barrington, NJ 08007) for \$16.95 plus postage by ordering Cat. No. D36,563.

A graph that profiles the airflow from a Module B fan is shown in Fig. 7. The relatively directional nature of the air flow makes this fan well suited for cooling individual components in a circuit, such as power transistors and transformers.

I've experimented with a Module B piezoelectric fan purchased from Edmund Scientific. This fan is designed to be powered directly by 117-volt, 60-Hz line current through a 33,000-ohm current-limiting series resistor. The fan moves 7 cubic feet of air per minute, and it consumes only about 10 percent of the power required by a conventional electromagnetic fan that moves the same amount of air. It starts instantly, requires no lubrication, produces no electrical noise, and is considerably quieter than a conventional fan.

The Module B piezoelectric fan has no bushings, bearings or other parts that

wear out. Therefore, its life expectancy is very long. The manufacturer claims to have operated identical fans for more than four years continuously without failure; so reliability is also very high.

A piezoelectric fan appears to be more fragile than an electromagnetic fan. Indeed, the instructions packed with the fan I purchased included the following caution notice:

"The gray ceramic driver for the blade is very delicate and easily broken. Exercise care in unpacking and handling. Handle fan motors without housing by the black mounting block *only*."

Though the driver elements are considered fragile, Piezo Electric Products claims the fan will survive a 4-foot drop to a concrete floor. While I haven't performed a drop test to verify this claim, I've physically restrained one or both of the vanes while they were in motion and intentionally allowed the moving vanes to strike many different objects. I've also driven the fan across a wide range of frequencies and with both sine waves (as recommended by the manufacturer) and square waves (which are definitely not recommended by the manufacturer). Even after all this abuse, my tortured little fan continues to gently buzz along even as these words are being typed.

Though Piezo Electric Products' piezoelectric fan is specified for operation at 117 volts (don't forget the series resistor!), the fan will operate at lower voltages with reduced air movement. This means you can power it with a simple battery-powered transistor or IC oscillator circuit and step-up transformer arrangement. The most important requirement is that the supply voltage be a 60-Hz sinusoidal wave. Other frequencies can be applied to the fan, but the vanes are designed to be mechanically resonant at 60 Hz and will not respond to other frequencies.

As I already mentioned, you have to see a piezoelectric fan in operation to fully appreciate the fact that it actually works. The second best way to demonstrate that these fans really work is to photograph the vanes of the same fan with the power switched off and then on.



Fig. 6. A fan manufactured by Piezo Electric Products, Inc.



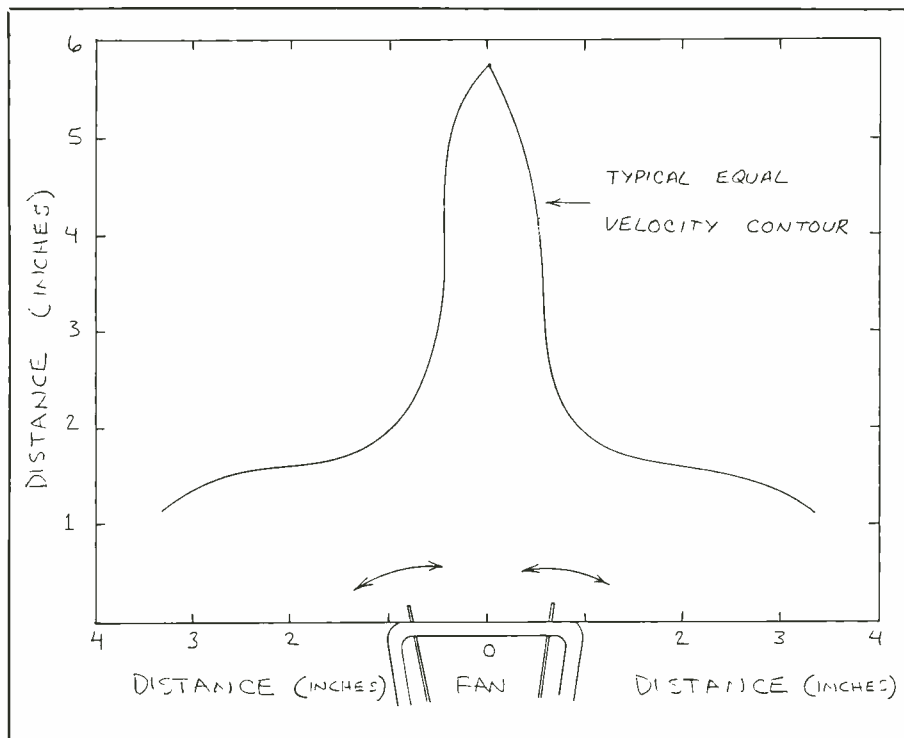

Fig. 7. Pattern of air movement from a Piezo Electric Products fan.

That is how I obtained the photos shown in Fig. 8.

For these photos, I mounted the fan on a small tripod, which I placed on a copy camera stand. Next, I directed two beams from a fiber-optic light source toward the vanes. I then adjusted the tripod so that the vanes diffusely reflected light from the fiber illuminator into the camera lens. As Fig. 9(B) reveals, the vibrating vanes

of the powered-up fan are clearly visible.

Now about that requirement that the drive voltage have a sinusoidal wave shape. I connected my fan to a frequency generator through an ordinary 6.3-to-117-volt transformer to boost the voltage. The fan operated properly when the frequency of the generator was adjusted to near 60 Hz. It worked much better when the wave was square as opposed to

when it was sinusoidal or triangular in shape.

The sound from the fan operated from square waves also became considerably louder. The relatively loud buzzing noise may itself be sufficient reason to drive the fan with a quiet sinusoidal wave. Worse, the noise may indicate that the bender elements are being subjected to much more mechanical stress than they are designed to accommodate.

An interesting experiment is to alter the operating frequency of a piezoelectric fan. To do this, first connect the fan to a frequency generator through a step-up transformer. If you don't have a frequency generator, use any circuit that generates an adjustable-frequency sine or triangle waveform.

Next, cut a 2 by 8-centimeter rectangle from a paper index card. Draw a line across the rectangle 2 centimeters from one end. Attach a piece of double-sided clear adhesive tape to the marked end of the rectangle. Then carefully attach the rectangle to the end of one of the fan's Mylar vanes so that the line on the paper is even with the end of the vane. The vane is now 6 centimeters longer than its original length.

Now slowly increase the frequency of the signal applied to the fan. I found that the extended vane oscillated over very narrow frequency ranges centered around 12, 40, 125, 255, 300 and 425 Hz.

You can vary the length of the vane extension to obtain different results, of course. The easiest way to do this is to start with a 6-centimeter (or longer) extension and trim away segments with scissors. For example, I clipped the paper vane at the node produced when the fan was driven at 40 Hz. This shortened the vane by 2.2 centimeters and changed the resonant frequencies to 25, 65, 200, 300 and 450 Hz. The 200-Hz frequency was particularly noisy.

### Going Further

Next month, we'll experiment with piezoelectric high-voltage trip hammers and sound disks. We'll also experiment with a remarkable piezoelectric plastic film. **ME**

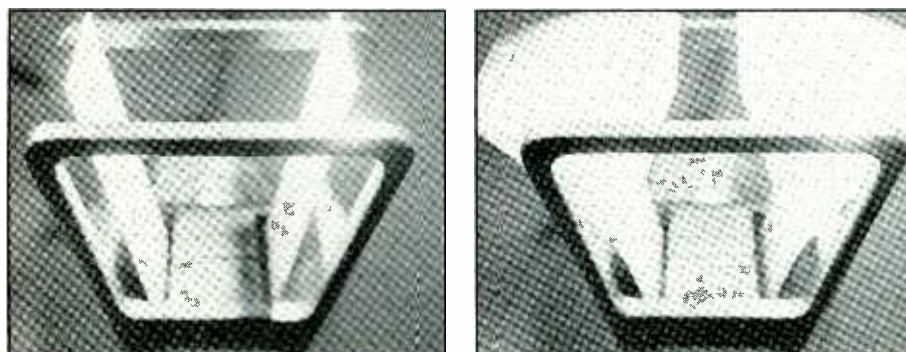

Fig. 8. The vanes of a piezoelectric fan with (A) no power and (B) power applied.

## *Evaluating Three Image-Manipulation Packages: Astral Development's "Picture Publisher," Silicon Beach Software's "Digital Darkroom" & Inset Systems' "Hijaak V. 1.1B"*

By Ted Needleman

Last month, we looked at several video capture boards as a way of getting graphic images into desktop publishing, presentation graphics and word processing documents. Of course, using a frame grabber isn't the only way to capture an image. In fact, it is downright awkward in capturing two-dimensional images such as photographs. The best way to grab these kinds of images is with a scanner. I have two or three of these coming in, and I'll let you know what I think of them at a later time.

Images, whether captured with a frame grabber, scanner, or obtained as clip art, are seldom usable "as-is." They often have to be cropped. You could use most of the popular paint-type packages to do this, though this approach is often tedious at best. A better choice for many is a package designed especially for image manipulation, such as the ones I'm going to talk about this month.

### **Picture Publisher**

A skilled photographer can perform miracles in a darkroom. Using advanced photographic techniques, often called "trick photography," he can insert or remove people and things from a photograph. Everyone has seen the results of such manipulation at one time or another. Picture Publisher is the electronic equivalent of a studio darkroom. The software package is designed to let you modify the gray-scale content of an image.

A photograph is not made up of just pure black and pure white. It contains continuous tones, that is, shades of gray ranging from absolute black to the absence of any gray whatsoever (white). It is this gradient of shade that is called a gray-scale.

When an image is scanned or captured by a frame grabber, each pixel (picture element) of the image can be only black or white. The sensors, usually CCDs in most



*Image of author's son captured with Publishers' VGA and printed with Picture Publisher on H-P LaserJet +. Dithering and halftone screen are very pronounced.*

image capture devices, are not set up to output levels of blackness. A technique which consists of examining the neighboring pixels and averaging their blackness or whiteness is used to "estimate" the gray content of a pixel. Depending on the particular device being used to capture an image, and the software being used with it, you will commonly obtain 32, 64, or 256 levels of gray.

Picture Publisher, running under Microsoft Windows, allows you to display up to 64 levels of gray (assuming you are using a monitor capable of displaying a gray-scale image, such as a VGA or desktop publishing oriented black and white monitor), and manipulate up to 256 gray levels.

Picture Publisher works with TIFF format files. Where these files originate is unimportant as far as using the software, except that the more levels of gray the originating device is able to provide, the more manipulation you will be able to perform on the image.

Once you've started the software, by typing WIN ASTRAL, you will see the

familiar Windows pull-down menu interface. Load in a TIFF file, and a small representation of the image appears on the right-hand side of the Picture Publisher window. You can see the image in greater detail by selecting a scale in the VIEW menu, then choosing the eXchange menu selection (or just typing an X). This flips the display into a full-page window, which will display the image as either a complete image scaled to fit the full display, a 100-percent pixel-for-pixel display, or 200-, 300-, or 400-percent view for high-resolution editing. You can also specify a custom view to encompass any image area.

Images can be edited and processed in a wide variety of ways. The GrayMap menu allows you to adjust the threshold at which a pixel is recognized as black or white. You can Posterize an image (similar to the solarization often used in photographs), or flip positive and negative tones to create a negative image. A Threshold command allows you to turn an image into a fine-art representation, while highlights, shadow areas, and mid-





*Same image file as before printed on an Apple LaserWriter Plus PostScript printer. Image is much softer, though half-tone screen is still visible.*

tone values in the image can be adjusted using the ToneMap and Quartertone menu choices.

IMAGE RETOUCH menu selections provide a variety of tools to clean-up an image. You can select a gray level from the image or a palette, and spray-paint areas of the image. You can clone (replicate) selected areas of the image, or use variable Sharpen or Smooth filters to enhance or blend areas of the image you are working with.

Other filters, which provide image-wide (global) effect can be found in another pull-down menu—PROCESS. PROCESS also gives you the ability to size, scale, and rotate images, as well as mirror an image horizontally or vertically. You can also modify the image resolution in pixels/inch through this menu.

One of the more powerful image-editing functions you can perform with Picture Publisher is achieved by masking areas of your images with the tools in the MASK menu, then cutting and pasting portions of images to the clipboards the program provides. When you combine

these pieces of pictures, you can create your own reality—"doctored" pictures created electronically.

Picture Publisher is a useful program if you do much imaging for desktop publishing or presentation graphics. It is also a lot of fun, especially if you occasionally get hit with a creative urge. To really get the most out of it, though, will take a bit of experimenting—it's a very visual, rather than intellectual process. And though the software is usable with PCL laser printers such as the Hewlett-Packard LaserJet, it seems to give slightly better output results with PostScript printers. PCL printers are accommodated with a dithering technique Astral calls ScatterPrint, but the results I obtained out of an Apple LaserWriter Plus were much more impressive.

As impressive as Picture Publisher is, it does have a few "warts," mostly in the area of documentation. The manual that accompanies the software is very attractive, but it assumes a good deal of photographic and image processing background, and is sparse in a few key areas.

First of all, there are no installation instructions whatsoever.

If you examine the directory on the program disk, you'll find an install batch file which takes you through the quick task of creating subdirectories and copying files from the program and sample pictures disks. But the manual starts with the assumption that you've already (and successfully) installed both Windows (which this program runs under) and the Picture Program itself.

Astral's assumption about the background and expertise of its users may be entirely on target, but I don't recall *ever* having seen a piece of microcomputer software without some text on installing the program, even if that explanation was a single sentence: "Place Program Disk in Drive A: and Type INSTALL."

Another place where the documentation falls down is in the area of printing. There is a section on how to "calibrate" your output by scanning a gray-scale card, but no discussion on printers beyond this. Again, I think that Astral feels most of their users are beyond this, but *this* user would have appreciated a bit more of the mundane detail.

Even without what I consider to be "complete" documentation, I had no trouble installing and using Picture Publisher. And it was kind of fun "tweaking the knobs" and seeing the results.

Not everyone will want or need the image manipulation power Picture Publisher provides. But if you do, the \$599 price of this package is well worth it. The software does require a fairly hefty MS-DOS machine. Since it runs under MS-Windows, an 80286 with 512K or more of RAM and a hard disk is about the least amount of hardware I would advise. I've run it on both a Compaq DeskPro286 (a 12-MHz system) and an ACER 1100 (a 16-MHz 80386). It ran satisfactorily on the 286, but if I was going to do some heavy-duty image processing, I'd want the 386.

You will also need a VGA graphics adapter and monitor to edit the image.



# PC CAPERS...

All this adds up in terms of cost, but the results can be stunning.

## Digital Darkroom

Not everyone uses an MS-DOS computer, of course. Now, with your Macintosh, a scanner or other video capture device, and Silicon Beach Software's Digital Darkroom, you can perform the same kind of image manipulation tricks the MS-DOS folks accomplish with Picture Publisher.

All image processing and manipulation packages, whether for the IBM or the Mac, seem to have certain basic functions in common. Working on a base image, the software allows you to perform a variety of operations, including blending additional images onto (and into) the original. You can control the brightness and contrast of both the entire image and selected parts of the image. Other menu selections allow you to rotate, flip, scale, stretch, slant, and distort parts of images. In fact, one of the examples given in the documentation shows the Leaning Tower of Pisa in its natural state, then restored to vertical.

Other menu selections let you apply various filters to the picture elements. These functions allow you to sharpen and blur, invert images (create a negative), and posterize, which gives a result similar to solarization performed in the darkroom. Touchups of images can be accomplished with the "brush" and "airbrush" tools provided. By using the neighboring parts of an image as the palette, you can even make parts of the picture disappear.

Digital Darkroom even allows you to enhance your output by offering two halftoning methods. There is a "Standard Halftone" method for printing on PostScript printers and typesetters. There's also an "Advanced Halftone" method, for 300-dpi laser printers, which Silicon Beach claims to give a much cleaner and crisper output. When I tried the two options I didn't get the dramatic-

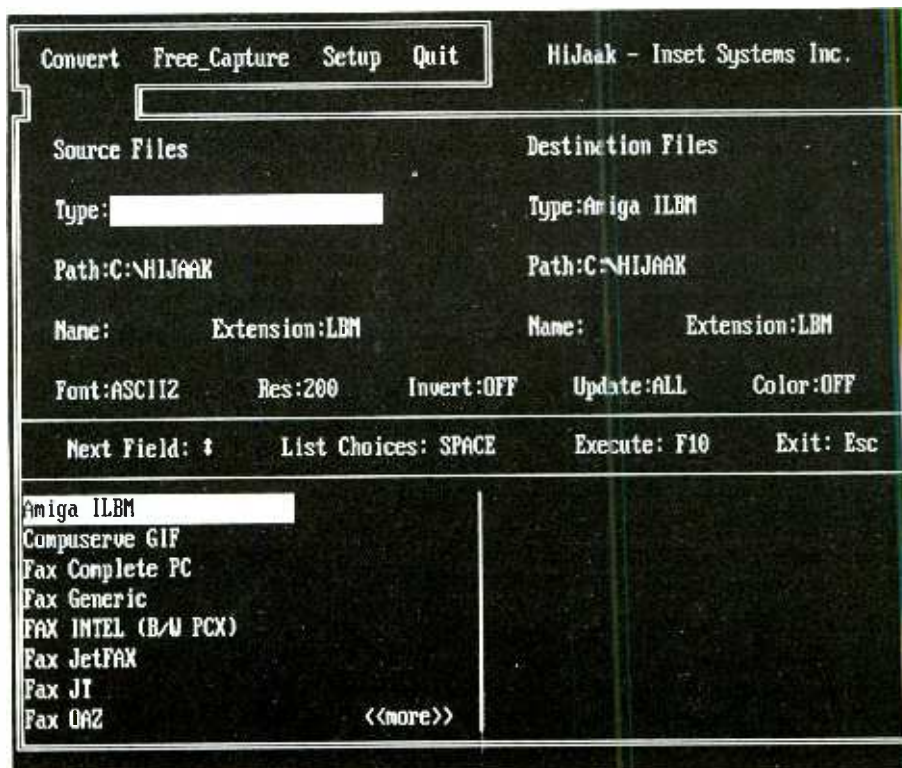

Control panel of Hijaak package, captured with Hijaak's Capture feature.

ally different results they show in the documentation, but the "Advanced Halftone" did appear to be a bit crisper.

Incidentally, Digital Darkroom is not only meant for use with a scanner. It can import files in most popular Macintosh image formats, including TIFF, PICT, ThunderScan, and MacPaint. It also exports EPS (Encapsulated PostScript) and Adobe Illustrator files.

Digital Darkroom was easy to install (just drag the folders over to the hard disk), but learning how to use it took a bit of time. It's a very powerful piece of software, and you need to experiment with it to get a feel for what it can do. The documentation is excellent and includes a tutorial and sample image files to work on.

You will also need more than a minimum Mac to get much use out of the package. Silicon Beach recommends at

least 1MB of memory and a hard disk. The software itself uses 350K of RAM when loaded, in addition to the memory taken up by the System and Finder. When you consider that an 8 by 10 photo scanned at 150-dpi resolution with 256 levels of gray takes up almost 2 megabytes of disk (and RAM when it is loaded), you'll begin to understand why 1MB of RAM doesn't go very far.

I used the package on both my 512E (with 1MB RAM) at home, and the MAC SE/30 I have in the office. It did run on the 512E, but I got a bit tired of getting "Not enough memory" messages when trying to load images. The software ran fine, though, on those images I was able to load. At least I thought so until I ran Digital Darkroom on the SE/30. The difference in speed between the older 68000-based Macs and the new 68030

SE/30 and Mac IIs is akin to that between 286- and 386-based MS-DOS systems, and this was very evident in running the image processing package.

Another problem lies with the Mac itself. Except for the Macintosh II, most Macs are incapable of displaying a gray-scale image. This means that you will most likely have to keep printing out your image to see the results of operations, such as blurring and sharpening, which modify the gray-scale. This can be tedious after a while. (Actually, this got tedious after the second time.)

If you have a loaded Mac II or a Plus or SE with lots of RAM, you're going to love this package. It takes a little time to learn, but so do the photographic darkroom techniques. And when you use Digital Darkroom, you stay dry and can keep the lights on.

## Hijaak

As you can tell from the two reviews above, I spend a good deal of time on two different systems. And I've often been frustrated because the Mac seems to have better graphics software than my PC, while I prefer to word process and run PageMaker on the MS-DOS side. I've had pretty good luck over the years transferring files with products such as Traveling Software's Lap-Link MAC and Dataviz's MACLink. But the problem of incompatible file formats has sometimes been a tough nut to crack.

The problem of incompatible systems and graphic file formats has pretty much been solved with Hijaak from Inset Systems, Inc. Running on an IBM PC or compatible, Hijaak lets you take an image file in one format and easily convert it into a different format. Files captured or created on a Macintosh or Amiga, which are known for their graphics manipulation ability, can be run through Hijaak and used with applications on your PC (or vice-versa).

Hijaak's CONVERT command can translate between a wide variety of file

formats. These formats include Amiga (.IFF); Group 3 Fax (.FAX); Compu-Serve Image Format (.GIF); Dr. Halo (.CUT); GEM Paint (.IMG); HP LaserJet (.PCL & .HPC); HP 7440 Platter (.PGL); Lotus 1-2-3 (.PIC); Lotus Freelance (.PIC, .PGL, .PCL); Macintosh (.MAC); NewsMaster (.SHP); PC Paintbrush (.PCX & .PCC); PostScript (.EPS); PrintMaster (.PM); all TIFF file formats; Text files (.TXT); Windows Paint (.MSP); and WordPerfect (.WPG). In addition to the application packages listed above, many other software packages use one of the above file formats and produce files that can be converted with Hijaak.

Hijaak also has a versatile capture feature. It can capture graphics screens from systems using a wide range of display adapters, including CGA, MCGA, EGA, VGA, Hercules, and the Wyse 700 and Genius high-resolution monitors. While these features are available to one extent or another in other programs, Hijaak's ability to capture data being sent to a LaserJet printer or to a plotter is unique.

Similar in operation to a print spooler, Hijaak saves the captured file in a graphic image format that can be further manipulated with any of the popular graphics editors or even a package such as Astral's Picture Publisher.

Do you have graphics files produced by AutoCAD, PageMaker, or other graphics-based software that you'd like to send via fax? Hijaak will let you do it. It can convert FAX files used with many of the popular PC fax boards into graphic image files that can be used with most of the above programs. The conversion process works both ways. Therefore, you can first convert an AutoCAD or other image file to FAX format, transmit it through a fax board, and turn it back into an image file on the other side.

Setting up and using Hijaak is easy. If you have a hard disk, just copy the two disks supplied into a new subdirectory named HIJAAK. On floppy-based systems, make copies of the disks and use the

copies. Run Hijaak and choose SETUP from the menu. Tell the software about your hardware configuration, and you're ready to start converting files. Hijaak's main screen is a panel in which you select the source and target files, their data paths, and the formats they originate and should end up in. When this information has been entered, just tell Hijaak to go to it by pressing the F10 function key. Hijaak provides a bar gauge which shows you how the conversion is progressing.

I loved Hijaak. It's simple to use, amazingly versatile, and works exceedingly well. If you are at all involved with desktop publishing or graphics, it's likely that sooner or later you'll need Hijaak. Do yourself a favor and make it sooner.

ME



**Be an FCC LICENSED ELECTRONIC TECHNICIAN!**

Earn up to \$30 an hour and more!

Learn at home in spare time. No previous experience needed!

No costly School. No commuting to class. The Original Home-Study course prepares you for the "FCC Commercial Radiotelephone License". This valuable license is your "ticket" to thousands of exciting jobs in Communications, Radio-TV, Microwave, Computers, Radar, Avionics and more! You don't need a college degree to qualify, but you do need an FCC License. **No Need to Quit Your Job or Go To School** This proven course is easy, fast and low cost! **GUARANTEED PASS**— You get your FCC License or money refunded. **Send for FREE facts now. MAIL COUPON TODAY!**

**COMMAND PRODUCTIONS**  
FCC LICENSE TRAINING, Dept. 220  
P.O. Box 2824, San Francisco, CA 94126  
Please rush FREE details immediately!

NAME \_\_\_\_\_  
ADDRESS \_\_\_\_\_  
CITY \_\_\_\_\_ STATE \_\_\_\_\_ ZIP \_\_\_\_\_

## Something to (Twist &) Shout About

By Joseph Desposito

Unlike the Beatles, Software Toolworks is not doing a remake of the Isely Brothers popular tune, "Twist & Shout." The company is just borrowing the title. Twist & Shout (Ver. 1.09) is actually three products in one: Twist, Shout, and Disk Spool II. Twist is a program for printing spreadsheets sideways for extended-length printouts, Shout is for creating banners, and Disk Spool II is a print spooler. The product is for IBM compatible PCs and requires 384K memory. It comes with both 5¼" (two) and 3½" (one) floppy disks and includes well-written User's and Reference Guides. Software Toolworks, 19808 Nordhoff Place, Chatsworth, CA 91311, has priced Twist & Shout at \$79.95. The program is not copy protected.

To use any of the programs, Twist, Shout, or Disk Spool II, you enter its name at the DOS prompt. All programs make use of Lotus 1-2-3 style menus and all support a mouse (except when Twist is used as an add-in). Installation is straightforward. You type INSTALL at the A: prompt, and the program prompts you for the necessary information about printers and whether you want to install it to run stand alone or as an add-in to another product such as Lotus 1-2-3 (Ver. 2.0 or 2.01). The install program is very well done and makes good use of color (if your system supports it).

### Twist

To print spreadsheets sideways from the stand-alone version of Twist, you type TWIST at the DOS prompt. Eventually, a screen appears that looks very much like a screen from Lotus 1-2-3 after a slash (/) has been pressed, except that the menu says:

Read Path Extension Quit

There's even a READY sign in the upper right-hand corner that changes to a blinking WAIT after you've made a menu selection.

You choose a file to be "twisted" by selecting Read and choosing a file from a

```

File: C:\TS\SAMPLE.WKS
Margins: Double-strike Type size Spacing Width Bidirectional Lotus
Select the size of the characters to be printed
READY

File Path: C:\TS\*. *
Printer: IBM Graphic
Country: United Stat
Paper Width: STANDARD (8
Spacing: 2 dot(s) b
Spacing: 1 dot(s) b
Characters: 10.2 per inc
Lines: 6.0 per inch 48 per page

TINY 120 lines
TINY 96 lines
TINY 80 lines
SMALL 73 lines
SMALL 60 lines (draft)
MEDIUM 60 lines
MEDIUM 53 lines
MEDIUM 48 lines
LARGE 48 lines (draft)
LARGE 41 lines (draft)
LARGE 40 lines (draft)
X-LARGE 36 lines (draft)
X-LARGE 33 lines
X-LARGE 30 lines (draft)

Device: LPT1
Ctional: YES
Strike: NO
tuation: ({P})
urrency: MM/DD/YY
Format: HH:MM:SS
uppress: NO
Margin: 0.0"
Margin: 0.0"
Left Margin: 0.0"

F1 for Help
    
```

Printout of the opening Lotus 1-2-3-like Shout screen display.

First, you may select character sizes that range (for an IBM Graphics Printer) from about ⅛ inch high and barely readable to ⅜ inch high; next, if you have a color printer, you may print different parts of the spreadsheet in different colors; and other enhancements are available that pops up in a window on the screen. Once you've chosen a file, the menu changes to:

Twist Enhancements File Options Quit

Twist lets you change the look of the spreadsheet printout in a variety of ways.

able, too, such as double-strike, underline, boldface, italics, and variable spacing between letters. Since Twist uses the graphics capabilities of a printer to print sideways, it cannot take advantage of any built-in fonts that a printer may have. The program supports hundreds of dot-matrix, color and laser printers.

Twist will print Text (ASCII) files sideways or any one of a number of standard file formats. For example, it can print Lotus WKS and WK1 files, Symphony WRK and WR1 files, and Quattro WKQ files directly. Twist can also be called directly from some programs. You can use



The four type fonts available with Shout for printing banners.



it as an add-in to Lotus 1-2-3 (Ver. 2.0 or 2.01), Quattro, Framework II and III, Symphony, and VP Planner Plus. How to add Twist to any of these programs is clearly explained in the User's Guide. We tried adding Twist to Framework III and Quattro. The installation procedure was fairly simple and Twist worked flawlessly. When you use Twist as an add-in to any of the programs mentioned above it takes up about 60K of memory. Twist has context-sensitive help available at the press of the F1 function key.

The only problem we had with Twist was when it printed over the perforation in tractor-feed paper. Numbers were either bunched up or spread out. Although this was caused by a mechanical problem between printer and paper rather than through any fault of the program, it would never happen when printing vertically since the printer skips over the perforation.

### Shout

Shout is used for printing banners such as "Welcome Home, Mom and Jennifer." You start it by typing Shout at the DOS prompt. Shout has four type styles: Times Roman, Olde English, Sans Serif, and Script; and it can print in sizes ranging from two to six inches. You may also choose from among 52 symbols such as a birthday cake, star, baseball, heart, etc., to jazz up the look of your banner.

The opening Lotus 1-2-3 style menu offers the following choices:

#### New Read Path Quit

If you choose New, a screen appears that lets you enter up to four lines (for standard paper) of any length for a banner. A neat feature is a counter at the bottom of the screen that indicates how many pages long your banner will be.

Shout can print your banners using either the text or graphics mode of the printer. When using the text mode, Shout forms large letters by combining many smaller letters. For example, an H would be printed with a lot of little h's. You could also choose a single character, such as an asterisk, to create all the letters.

Although Shout has a preview mode, it



Sampling of graphics symbols available with Shout.

is not capable of letting you preview a WYSIWYG (what you see is what you get) copy of the output. Since Shout displays all of its information in the text mode on screen, it cannot show any graphics symbols or different font styles. Instead it tells you with a message. Symbols are entered into the banner by pressing Alt-S and then choosing a symbol from a list in a pop-up window. Shout inserts a letter into the space where the symbol will be.

### Disk Spool II

This is a print spool program designed to let you continue controlling your computer while printing files. You start it by entering SPOOLII at the DOS prompt. Once you do this, the program becomes memory resident (taking up about 25K RAM) and will spool any future print jobs to disk and then to the printer. This lets you regain control of your program

much faster than you normally would. A menu can be popped up by pressing Alt-Left Shift. This lets you do things such as abort printing and spool to disk but not to a printer (for printing at a future time). The program worked as expected.

### Conclusions

Twist & Shout combines three handy programs into one package that sells at a reasonable price. And each is easy to use and useful, too. I would only caution users of Lotus 1-2-3 (Ver. 2.01) who intend to upgrade to version 2.2 that this new version of 1-2-3 is rumored to already contain a sideways printing program. For others, though, who find themselves spending inordinate amounts of time pasting spreadsheet pages together for a sideways presentation, and are also attracted to the other features of Twist & Shout, I recommend that you "shake it up, baby" and go and buy yourself a copy. **ME**



### Free Product Information

Readers can obtain free information on products advertised by certain companies, as well as for some editorially mentioned products. Simply circle the appropriate number printed below an advertisement onto the Modern Electronics "Free Information Service" card bound into this issue. After filling in your name and address, just mail the postpaid card. Your request will be forwarded directly to the advertiser with a mailing label prepared by our reader-service department to ensure speedy response.

## CABLE T.V. CONVERTERS

WHY PAY A HIGH MONTHLY FEE?

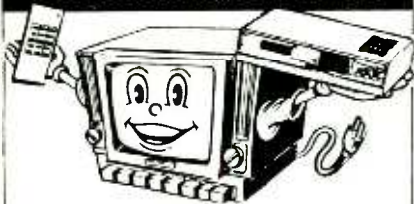

All Jerrold, Oak, Hamlin, Zenith, Scientific Atlanta, Magnavox and all specialized cable equipment available for shipment within 24 hours. For fast service MC / VISA or C.O.D. telephone orders accepted (800) 648-3030 60 Day Guarantee (Quantity Discounts) 8 A.M. to 5 P.M. C.S.T. Monday through Friday. Send self-addressed Stamped envelope (60¢ postage) for Catalog

**MIDWEST ELECTRONICS INC.**

5143 (ME) W. Diversey  
Chicago, IL 60639

No Illinois Orders Accepted

### CABLE T.V. CONVERTERS

Jerrold®, Oak, Scientific Atlantic, Zenith, & many others. "New" MTS stereo add-on: mute & volume. Ideal for 400 & 450 owners!

1-800-826-7623

**B & B INC.**

4030 Beau-D-Rue Drive, Eagan, MN 55122

### CABLE-TV BOXES

Descramblers • Converters  
**FREE CATALOG**

**TRANS-WORLD CABLE CO.**  
12062 Southwest 117th Ct., Suite 126  
Miami, Florida 33186  
800-442-9333

### SURVEILLANCE TELEPHONE

This is a normal functioning telephone! EXCEPT it has a secret built in monitor. Only YOU can call and monitor all conversations, using a secret code. and never be detected! Range Unlimited  
\$175.00 - 6 month Warranty - Phone Tap Catalog \$3.00  
LISTEN ELECTRONICS, 603 Egan, Muskogee, OK 74401  
1-800-633-TAPS



### PICKS UP A WHISPER 50 FEET AWAY!

The model WAT-50 miniature FM transmitter uses a 4-stage circuit NOT to be confused with a simple wireless microphone. Simply snap the unit on top of a 9V battery and you can hear every sound in an entire house up to 1 mile away! Use with any FM radio. Tunes to any frequency from 70mhz - 130mhz. Easy to assemble kit includes all parts and instructions. Only 29.98 tax incl.



The **WIRELESS TELEPHONE TRANSMITTER** model WTT-20 is only about the size of a dime, yet transmits both sides of a telephone conversation to any FM radio with crystal clarity. Completely automatic. Uses power from the telephone line itself - never needs a battery! Up to 1/4 mile range. Tunes from 70mhz - 130mhz. Easy to assemble kit includes all parts and instructions. Only \$29.98 tax incl.

Call or send MO, VISA, MC for immediate delivery. Single kit orders include \$1.50 S&H. FREE SHIPPING on orders of 2 or more. All orders shipped by U.S. Mail. COD add \$4.00. Personal checks allow 21 days.

**DECO INDUSTRIES**  
BOX 607, BEDFORD HILLS, NY 10507  
914-232-3878

CIRCLE 41 ON FREE INFORMATION CARD

# MODERN ELECTRONICS MART

**Classified Commercial Rates:** \$1 per word, 15-word minimum (\$15.00) prepaid. (Word count includes name and address; ZIP code and abbreviation each count as one word; P.O. Box number and telephone number count as two words each.) Indicate free category heading (**Computers, Communications, Electronics, Video or Miscellaneous**). A special heading is available for a \$6 surcharge. First word only is set boldface caps at no charge. Add 20% for additional boldface words.

**Non-Commercial Rates:** FREE to subscribers, as space permits; maximum 15 words. A recent **MODERN ELECTRONICS** mailing label must accompany ad.

(All advertisers with P.O. Box addresses must supply permanent address and telephone number. Copy is subject to publisher approval.)

**Mailing Information:** Copy must be received by the publisher by the 25th of the third month preceding the cover date. Send Advertising material with check or money order or credit card information (Visa or MasterCard only) with number and expiration date to **MODERN ELECTRONICS**, Classified Department, 76 N. Broadway, Hicksville, NY 11801.

## VIDEO

**DESCRAMBLERS.** All brands. Special: Jerrold combo 400 and SB3 \$165. Complete cable descrambler kit \$39. Complete satellite descrambler kit \$45.00. Free catalog. MJO INDUSTRY, Box 531, Bronx, NY 10461-0531.

**VHS-VCR Repair Solutions Volumes I,II,III, IV.** Each contains 150 symptoms and cures, cross reference chart, free assistance. Each \$11.95, any two \$19.95, any three \$29.95, all \$39.95. Eagle Electronics Box A, 52053 Locks Lane, Granger, IN 46530.

**SATELLITE** descrambling-Cable descrambling. Send stamp for catalog. Communications Engineering, 76 Boulevard, Hudson Falls, NY 12839.

**HOW TO KEEP YOUR VCR ALIVE**—"This detailed, step-by-step manual enables anyone with no previous knowledge or experience to fix most VCR problems easily, quickly, and inexpensively with a few simple tools."—*Small Press Review*. "A handy book"—*This Week in Consumer Electronics* 376-page book, with 704 illustrations, plus professional head-cleaning tool, \$24.95. Mail check or MO to Worthington Publishing Company, 6907 Halifax River Drive, Suite 202K, Tampa, FL 33617. Faster: call (813) 988-5751 for C.O.D., Visa, of Mastercard. Money-back satisfaction guarantee.

## ELECTRONICS

**VOICE Disguisers! FM Bugs! Telephone Transmitters! Phone Snoops! Bug Detectors! More! Catalog \$1.00: XANDI ELECTRONICS, Box 25647, "LL", Tempe, AZ 85285-5647.**

**TUBES, Name Brands, New, 90% off list, Kerby, 298 West Carmel Drive, Carmel, IN 46032.**

**CB Tricks of the Trade book, CB repair tricks and tuning tricks. Send \$19.95 to Medicine Man CB, P.O. Box 37, Clarksville, AR 72830.**

**CRYSTAL-controlled FM transmitter kit, transmit to scanner 1/2 mile away in 49MHZ CB or 50MHZ amateur band. Sensitive VOX circuit prolongs battery life, can be activated by a voice 25 feet away. \$29.95 postpaid. Andromeda Electronics, 125N Prospect, Washington, NJ 07882.**

**TRACKER** circuit for your x/y input oscilloscope. Simple transformer/resistive circuit. Test diodes, transistors, IC's. Complete plans \$8.00, kit \$24.95, assembled \$34.95. Tech Center, 200 North Madison, Edmond, OK 73034.

**WANTED**—Highly sensitive hearing devices, also pen radio frequency jammer "Room Size". Eugene Dell, 1416 E. Market St., York, PA 17403 (717) 845-9945.

**GRAB Bags!** Electronics stuff. \$2.50 plus \$1.50 postage and handling. U.P. Products, P.O. Box 1619, Royal Oak, MI 48068.

**LET** your computer teach you electronics. Our home-study courses include computer movies and computer lab experiments. Our products are used in hundreds of community colleges and technical institutes. Now, you can have the same high-tech approach to learning in your own home. Low cost, pay as you go. Malvino Inc., 229 Polaris Ave., Suite 17M, Mt. View, CA 94043.

**TELEPHONE** Transmitters, Surveillance, Countermeasures Equipment. Covert plans and Kits Available. High quality electronics at lower prices. Free brochure: CSI, P.O. Box 244 Dept-E1, Aurora, CO 80040.

**ELECTRONIC COMPONENTS** Free 192 page catalog including capacitors, resistors, relays, connectors, soldering equipment and supplies. Box 699, Mansfield, TX 76063. 1-800-992-9943.

**LASER LISTENER II**, other projects. Bugging, descrambling, false identification, information. Plans, kits, other strange stuff. Informational package \$3.00 refundable. DIRIJO/BOND ELECTRONICS, BOX 212, LOWELL, NC 28098.

**AT LAST!** An educational and practical circuit! Mutes stereo/TV when phone rings or is in use. Schematic \$5.00. With power supply. Phone jacks \$14.00. **COYOTE CONTRAPTIONS, 1906 S. Espina, Suite 30, Las Cruces, NM 88001.**

**PROTECT YOUR HOME AND BUSINESS** FROM ELECTRONIC EAVESDROPPING AND WIRE TAPPING! COMPLETE COUNTER MEASURES CATALOG, \$3.00 "REFUNDABLE." **DIVERSIFIED WHOLESALE PRODUCTS, BOX 1275-ME, REDONDO BEACH, CA 90278.**





7-8-344-453

INTEGRATED CIRCUITS SILICON TRANSISTORS DISC CAPACITORS PANASONIC V SERIES

Table with columns: Part No., Price, Description. Includes 7400 TTL and 7400 CMOS series.

Table with columns: Part No., Price, Description. Includes Micro and Memroy series.

Table with columns: Part No., Price, Description. Includes 1 AMP SILICON RECTIFIERS and 5% CARBON FILM RESISTORS.

Table with columns: Part No., Price, Description. Includes 1% METAL OXIDE FILM RESISTORS and TRANSFORMERS.

Table with columns: Part No., Price, Description. Includes DISC CAPACITORS.

Table with columns: Part No., Price, Description. Includes PANASONIC V SERIES Stocked Resistor Products.

Table with columns: Part No., Price, Description. Includes 4000 CMOS series.

Table with columns: Part No., Price, Description. Includes A/D & D/A and Interface series.

Table with columns: Part No., Price, Description. Includes 1 AMP SILICON TRANSISTORS.

Table with columns: Part No., Price, Description. Includes PANASONIC L SERIES Miniature Aluminum Electrolytic Capacitors.

Table with columns: Part No., Price, Description. Includes PANASONIC B SERIES Polyester Capacitors.

Table with columns: Part No., Price, Description. Includes PANASONIC B SERIES Quartz Crystals.

Table with columns: Part No., Price, Description. Includes 7400 CMOS series.

Table with columns: Part No., Price, Description. Includes 1 AMP SILICON TRANSISTORS.

Table with columns: Part No., Price, Description. Includes 1 AMP SILICON TRANSISTORS.

Table with columns: Part No., Price, Description. Includes 5% CARBON FILM RESISTORS.

Table with columns: Part No., Price, Description. Includes 1% METAL OXIDE FILM RESISTORS.

Table with columns: Part No., Price, Description. Includes TANTALUM CAPACITORS.

Table with columns: Part No., Price, Description. Includes 74100 TTL series.

Table with columns: Part No., Price, Description. Includes 1 AMP SILICON TRANSISTORS.

Table with columns: Part No., Price, Description. Includes 5% CARBON FILM RESISTORS.

Table with columns: Part No., Price, Description. Includes 1% METAL OXIDE FILM RESISTORS.

Table with columns: Part No., Price, Description. Includes TANTALUM CAPACITORS.

Table with columns: Part No., Price, Description. Includes PANASONIC OPTOELECTRONICS.

Table with columns: Part No., Price, Description. Includes 74100 CMOS series.

Table with columns: Part No., Price, Description. Includes 1 AMP SILICON TRANSISTORS.

Table with columns: Part No., Price, Description. Includes 5% CARBON FILM RESISTORS.

Table with columns: Part No., Price, Description. Includes 1% METAL OXIDE FILM RESISTORS.

Table with columns: Part No., Price, Description. Includes TANTALUM CAPACITORS.

Table with columns: Part No., Price, Description. Includes PANASONIC OPTOELECTRONICS.

Table with columns: Part No., Price, Description. Includes 74100 CMOS series.

Table with columns: Part No., Price, Description. Includes 1 AMP SILICON TRANSISTORS.

Table with columns: Part No., Price, Description. Includes 5% CARBON FILM RESISTORS.

Table with columns: Part No., Price, Description. Includes 1% METAL OXIDE FILM RESISTORS.

Table with columns: Part No., Price, Description. Includes TANTALUM CAPACITORS.

Table with columns: Part No., Price, Description. Includes PANASONIC OPTOELECTRONICS.

Table with columns: Part No., Price, Description. Includes 74100 CMOS series.

Table with columns: Part No., Price, Description. Includes 1 AMP SILICON TRANSISTORS.

Table with columns: Part No., Price, Description. Includes 5% CARBON FILM RESISTORS.

Table with columns: Part No., Price, Description. Includes 1% METAL OXIDE FILM RESISTORS.

Table with columns: Part No., Price, Description. Includes TANTALUM CAPACITORS.

Table with columns: Part No., Price, Description. Includes PANASONIC OPTOELECTRONICS.

The Dig. Key volume discount and service charges are subject to apply. Most items sold by Dig. Key will be combined for a volume discount. Items that are not discountable are identified by the suffix ND. ND items do not qualify for volume discount. After writing your order, total all of the items and apply the appropriate discount. To this subtotal, add the non-discountable items. Then add the service charge. We pay all shipping and insurance to destination in the U.S.A., Canada and Mexico when check or money order accompanies order. Dig. Key ships orders within the continental U.S., Alaska, Hawaii, Canada and Mexico.

WHEN ORDERING BY PHONE CALL 1-800-344-4538 (AK call 218-681-6674). BY MAIL SEND YOUR ORDER TO: DIGI KEY, P.O. Box 877, First Floor, Falls, MN 56701.

You may pay by check, money order, Master Charge, VISA or C.O.D. DIGI-KEY GUARANTEE: Any parts or products purchased from Dig. Key that prove to be defective will be replaced or refunded or returned within 90 days from receipt with a copy of our invoice. PRICES SUBJECT TO CHANGE WITHOUT NOTICE.

CIRCLE 43 ON FREE INFORMATION CARD

www.americanradiohistory.com

SERVICE CHARGES: \$6.00 per \$100. VOLUME DISCOUNT: \$100.00-999.99 Less 10%, \$1000.00-9999.99 Less 15%, \$10000.00 & up Less 25%.

July 1989 / MODERN ELECTRONICS 79



# NEW PRODUCTS!!

## IRON SLEEVE

Place a hot soldering iron in your toolkit without having to wait for it to cool!

Save wasted time! Increase productivity! Insulated carrier protects while it absorbs the iron's heat. Fits most popular soldering irons. 11" long tube 1.5" diameter. Only \$19.95. Three for \$49.95!

## WINDOW COUPLER

Run coax from outside to inside right through the glass! No Holes! No punched coax! No Draft! Many models!

SCANNER/TV 60-800MHz. 8db loss, "F" cons WFO-TV \$49.95

## APARTMENT ANTENNA!

VAK-TENNA mounts to window with suction cups. SCANNERS, TV, FM, HAM, 50-1000MHz. Specify UHF, BNC or F connector. \$25.95

## SIGNAL INTENSIFIER RF PREAMPLIFIERS

CB RFTX amplifies received signals. 13db! AM-\$49.95 SSB-\$64.95 VHF MARINE-\$99.95  
SCANNER RFP-40 0.5-1300MHz 15db gain. 2.9 nf BNC, UHF, F con. avail. 110AC power. \$69.95  
MANY MORE MODELS!

## TAPE SAVER

Connects your scanner to tape recorder for "action only" recording. \$49.95

ET ELECTRON PROCESSING, INC.  
P.O. BOX 708  
MEDFORD, NY 11763  
(516) 764-9798

SEND FOR FULL DETAILS!

ADD \$4 S/H & Tax if NY

CIRCLE 16 ON FREE INFORMATION CARD

## CABLE TV CONVERTERS IN STOCK

Stocking all types of converters: Panasonic, Jerrold, Tocom, Pioneer, Scientific Atlanta, Zenith, Oak, Hamlin, Eagle, and others.

Call or write for FREE CATALOG  
Mon - Fri 10 to 6 Eastern Time

## VIDEO-LINK

Enterprises, Inc..

165 W. PUTNAM AVE.

GREENWICH, CT 06830

Phone (203) 622-4386

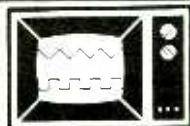

## FINALLY!

An interesting and worth-while project. This EASY-TO-BUILD circuit lets you use any regular TV set as a simple OSCILLOSCOPE. Build for less than \$10. NO MODIFICATIONS TO TV! Single or dual trace. Send for FREE CATALOG of other plans and kits.

DETAILED PLANS: \$4.95

## TV-SCOPE

PENN RESEARCH, Box 3543  
Williamsport, PA 17701

## Free Product Information

Readers can obtain free information on products advertised by the above companies, as well as for some editorially mentioned products. Simply circle the appropriate number printed below an advertisement onto the Modern Electronics "Free Information Service" card bound into this issue. After filling in your name and address, just mail the postpaid card. Your request will be forwarded directly to the advertiser with a mailing label prepared by our reader-service department to ensure speedy response.

## REMOTE CONTROL KEYCHAIN

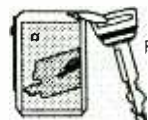

Complete w/mini-transmitter and +5 vdc RF receiver. Fully assembled including plans to build your own auto alarm. Write for more information. Quantity discounts available.

ONLY \$19.95

Check, Visa or M/C  
30 days refund  
Add \$2 shipping

VISITECT INC.  
PO BOX 5442, SO. SAN FRAN., CA 94080

(415) 872-0128

**DETECTION**—Surveillance, Debugging. Plans, Kits, Assembled Devices. Latest High-Tech Catalog \$5. **DETECTION SYSTEMS**, 2515 E. Thomas, #16-864H, Phoenix, Arizona, 85016.

**SURVEILLANCE**, Debugging, Protection. World's largest new catalog - \$5.00. Kits - Assembled - All price ranges, **TECHNOLOGY SERVICES**, 829 Ginette, Gretna, LA 70056.

**TEKTRONIX 545A** Oscilloscope, dual trace, 30MHz \$100.00 Test Equipment, parts. Low-est Prices. FREE Catalog. EF Electronics, Box 326, Aurora, IL 60506.

**CIRCUIT** boards for projects in this magazine (and past issues) about half price. **KLAY-Corporation**, 106 Mark Drive, Syracuse, NY 13209-1808.

**DESCRAMBLERS**, Test Equipment, Electronic Books, etc. Send \$2 for info to B and R Enterprises, P.O. Box 662, Portage, MI 49081.

## COMPUTERS

**POLICE** database program! Suspect Identification System matches case suspect descriptions with your department's known subjects. Retrieve records and print records by ANY descriptive criteria. One billion record capacity. Up to 20 times faster than dBASE! Requires MS-DOS, 512K, hard drive. Send \$89.95 to Nelson Communications, Box 946, Bronxville, NY 10708.

**COMPUTER REPAIR DEPOT**. IBM, Compaq, Apple, AT & T, and many others. Call Bi-Tronix, Inc. (408) 236-3385 or (209) 952-7116, PO Box 23069, San Jose, CA 95153.

## COMMUNICATIONS

**COMMUNICATIONS PLANS, BOOKS, KITS!** AM/FM broadcasting (licensed/unlicensed), 1750 Meter transceivers, ham/CB amplifiers, surveillance bugs, more! FREE catalog, PAN-COM, Box 130-ME7, Paradise, CA 95967.

**ALUMINUM** image transfer process, your artwork to aluminum. Write: J & E Enterprises, 2457 N. Marmora, Chicago, Illinois 60639.

## CABLE TV EQUIPMENT

**CABLE DESCRAMBLER LIQUIDATION**. Major makes and models available. Industry pricing! (Example: Hamlin Combo's, \$4 each . . . minimum 10 orders). **DEALERS ONLY!** Call West Coast Electronics, (818) 709-1758.

## CABLE EQUIPMENT

**CABLE TV Secrets** - the outlaw publication the Cable Companies tried to Ban. HBO, Movie Channel, Showtime, Descramblers, Converters, etc. Suppliers List Included. \$8.95. Cable Facts, Box 711-ME, Pataskala, Ohio 43062.

## VIDEOCIPHER II

**VIDEOCIPHER II** Manuals. Volume 1 - hardware, Volume 2 - software. Either \$32.45. Both \$54.95. Volume 3 - Projects/software - \$42.50. Volume 4 - Repair - \$97.45. CODs - 1-602-782-2316. Catalog-\$3.00. **TELECODE**, Box 6426-ME, Yuma, AZ 85366-6426.

## INVENTORS

**INVENTORS!** Can you profit from your idea? Call **AMERICAN INVENTORS CORPORATION** for free information. Over a decade of service, 1-800-338-5656. In Canada call (413) 568-3753.

## CABLE TV CONVERTERS

**YOUR** cable TV converter and descrambler bargain headquarters: Zenith, Tocom, Hamlin, Scientific Atlanta, Oak, Jerrold. Order yours today. VISA-MC COD. (415) 584-1627.

## AUTO SECURITY

**PROTECT** your automobile inexpensively! 15 minute installations, easy assembly. Complete, thorough instructions. Kit- \$5.99, Assembled- \$7.99. D-Btronics Inc., 111 Elk Trail, Carol Stream, IL 60188 (IL add 7%).

## CLASSIFIED ADVERTISING ORDER FORM

Mail this form with payment to MODERN ELECTRONICS, Classified Dept., 76 N. Broadway, Hicksville, NY 11801.

Name: \_\_\_\_\_

Street Address: \_\_\_\_\_

City: \_\_\_\_\_ State: \_\_\_\_\_ Zip: \_\_\_\_\_

Check category you wish to be listed under or note a special heading (\$6 additional) you want.

( ) Audio ( ) Communications ( ) Computers ( ) Electronics ( ) Video  
( ) Miscellaneous ( ) Wanted ( ) Special Heading \_\_\_\_\_

PRINT EACH WORD SEPARATELY. Note that P.O. Box numbers\* and telephone numbers must be counted as two words each. Circle additional words you wish boldfaced at 20% more each (initial boldface word is free). Minimum charge is for 15 words.

Free Boldface	2	3	4
5	6	7	8
9	10	11	12
13	14	15 (\$15)	16 (\$16)

CABLE TV

CATV converters & descramblers. Quality products. Professional service. Call 1-800-541-5487. VISA M/C accepted. Mountain-tech Inc., Box 5074, Mt. Crested Butte, CO 81225.

CABLE BROKERS

SURPLUS CATV converters and descramblers at wholesale prices. Unmodified units only, ex. OAK M35B \$30, Jerrold DRX3DIC w/remote \$80. (415) 337-8301.

ELECTRONIC COMPONENTS

FREE 192-page catalog including capacitors, resistors, relays, connectors, soldering equipment and supplies. BOX 699, MANSFIELD, TX 76063. 1-800-992-9943.

PROGRAMMABLE CONTROLLERS

POCKET CONTROLLER: Programmable Digital Controller. Designed for anyone that works with electronics. Only \$99.95. For literature, call (800) 533-7159, CT 791-8220, or write, Pocket Controller Company, Box 232, Seymour, CT 06483.

MISCELLANEOUS

ASIAN LADIES want correspondence for friendship, marriage, SUNSHINE INTERNATIONAL, Dept. TW, Box 5500, Kailua-Kona, HI 96745. (808) 325-7707.

ENSURE Personal alcohol tester. Avoid DUI arrest. \$155.00. Joseph's Gifts House, P.O. Box 15297, Atlanta, GA 30333.

A 6-Channel IR Remote-Control System (from page 47)

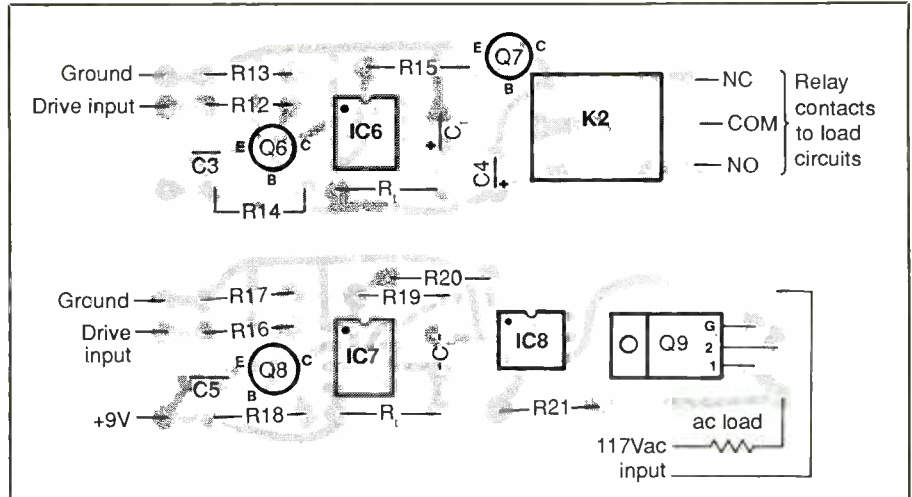

Fig. 13. Pc wiring guides for Fig. 10 (upper) and Fig. 11 (lower) circuits.

optical isolator.

This completes our discussion of interface circuits that can be used between the receiver/decoder and loads to be controlled. Obviously, we have not covered every possible type of in-

terface circuit. In fact, we have covered only a few of the many possible circuits that can be used in this system. You will undoubtedly think up other circuits that can be used for unique control applications. ME

TEXT TO SPEECH BOARD!

PC/XT COMPATIBLE. MAKE YOUR COMPUTER TALK! A VERY POWERFUL AND AMAZING SPEECH CARD. USES THE NEW GENERAL INSTRUMENTS SPO256-AL2 SPEECH CHIP AND THE CTS256A-AL2 TEXT TO SPEECH CONVERTER. THIS BOARD USES ONE SLOT ON THE MOTHERBOARD AND REQUIRES A COM SERIAL PORT. BOARD MAY ALSO BE USED IN A STAND ALONE ENVIRONMENT WITH ALMOST ANY COMPUTER THAT HAS A RS232 SERIAL PORT. FEATURES ON BOARD AUDIO AMP OR MAY BE USED WITH EXTERNAL AMPS. DEMONSTRATION SOFTWARE AND A LIBRARY BUILDING PROGRAM ARE INCLUDED ON A 5 1/4 INCH PC/XT DISKETTE. FULL DOCUMENTATION AND SCHEMATICS ARE ALSO INCLUDED.



NEW! PRICE CUT! \$6995 ASSEMBLED & TESTED

NEW! IC TESTER! \$149.00

SIMILAR TO BELOW EPROM PROGRAMMER. PLUGS IN TO YOUR PC OR XT. TESTS ALMOST ALL 14, 16, AND 20 PIN 74XX SERIES. INCLUDES STANDARD POWER, "S" AND "LS" DEVICES. ALSO TESTS CD4000 SERIES CMOS. SOFTWARE INCLUDED CAN EVEN DETERMINE PART NUMBERS OF MOST UNMARKED AND HOUSE NUMBERED DEVICES WITH SIMPLE MOD. THIS UNIT CAN ALSO TEST 6.4K AND 256K DRAMS! WITH MANUAL AND SOFTWARE: \$149. PERFECT FOR SCHOOLS.

PC/XT EPROM PROGRAMMER \$169

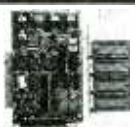

ASK ABOUT OUR NEW PAL PROGRAMMER!

\* LATEST DESIGN \* PROGRAMS UP TO 4 DEVICES AT ONE TIME \* FEATURES EASY TO USE MENU DRIVEN SOFTWARE THAT RUNS UNDER PC OR MS-DOS. \* USES AN INTELLIGENT PROGRAMMING ALGORITHM FOR SUPER FAST (8X) EPROM BURNING. \* THIS PLUG-IN BOARD ATTACHES TO AN EXTERNAL MINI CHASSIS CONTAINING 4 TEXT TOOL Z.I.F. SOCKETS. \* NO PERSONALITY MODULES REQUIRED \* AUTOMATIC VPP SELECTION: 12.5V, 21V, OR 25V. \* EPROM DATA CAN ALSO BE LOADED FROM OR SAVED TO A DISKETTE. \* PROGRAMMING SOFTWARE SUPPORTS: 2716, 2732, 2732A, 2764, 2764A, 27128, 27128A, 27256, 27256A, 27512, AND 27512A. \* ASSEMBLED AND TESTED, BURNED. IN WITH MANUAL. \$169 WITH SOFTWARE.

JUST RECEIVED. SAME AS ABOVE PROGRAMMER, BUT PROGRAMS 8 UNITS AT ONE TIME - \$299.

Digital Research Computers

P.O. BOX 381450 • DUNCANVILLE, TX 75138 • (214) 225-2309

TERMS: Add \$3.00 postage. We pay balance. Orders under \$15 add 75¢ handling. No C.O.D. We accept Visa and MasterCard. Texas Res. add 6-1/4% Tax. Foreign orders (except Canada) add 20% P & H. Orders over \$50 add 85¢ for insurance.

QUALITY PARTS DISCOUNT PRICES FAST SHIPPING

ALL ELECTRONICS CORP.

Grid of electronic parts including: 10 AMP SOLID STATE RELAYS, STROBE KIT, CASSETTE MECHANISM, PIEZO WARNING DEVICE, XENON TUBE, NICKEL-CAD BATTERIES, WIDE BAND AMPLIFIER, N-CHANNEL MOSFET, OPTO SENSOR, WALL TRANSFORMERS, SWITCHES, LED'S, RELAYS, SPDT PUSHBUTTON, and BI-POLAR LED.

ALL SALES SUBJECT TO THE TERMS OF OUR 90 DAY LIMITED WARRANTY. FREE COPY UPON REQUEST

CIRCLE 23 ON FREE INFORMATION CARD

CIRCLE 24 ON FREE INFORMATION CARD



## A Smart Weather Monitor (from page 53)

until you have rectified the problem.

When you have determined that the CPU module is correctly wired and is operating properly, connect the display board to it. For this, you need an 18-inch-long 20-conductor ribbon cable that is terminated at both ends with socket connectors. To avoid polarity problems, it is a good idea to insert "polarization keys" into holes 9 and 12 of the sockets.

With the cable plugged into both circuit-board assemblies, once again power up the project. Connect the meter's common lead to a convenient circuit-ground point on the display module board. Touching the meter's "hot" probe to pin 20 of the *IC101* through *IC108* and *IC110* sockets and to pin 16 of the *IC109* socket should yield a reading of +5 volts. You should obtain the same reading when touching the "hot" probe to pin 14 of the sockets for displays *DISP1* through *DISP6* sockets.

Again, if you do not obtain the proper readings at each point cited, power down the project and rectify the problem before proceeding.

When you have ascertained that both circuit-board assemblies are in proper working order, disconnect power from the project and wait a minute or two. Then install the ICs in the sockets on the CPU module board. Make certain that each IC plugs into its appropriate socket in the proper orientation (see Fig. 5). Also, make sure no pins overhang the sockets or fold under between ICs and sockets. Repeat for the display board and its ICs and displays.

### Test Program

Because of the complexity of WISARD, there is a basic MPU test built into its ROM. This test is accessed via option switch *S2* in the DIP package on the CPU module. When *S4* is set to "on" and the primary MCU circuit is performing properly, the display will flash on and off the message "6830UP." This message means that 6803 *IC1*, *IC3*, *IC10*, related address

decoding and the address and data bus are connected correctly.

With all ICs and displays installed in their respective sockets and *R37* properly adjusted, set options switches *S1* and *S2* to "on" and apply power to the circuit through the ac-operated power supply. If the display flashes the "6830UP" message, you are well on your way to completion of this portion of the project. If not, you must troubleshoot the circuit and correct the problem before putting the project into service.

Start with voltage checks. The potential at RESET pin 6 of *IC1* should measure greater than 4 volts (logic high). Use an oscilloscope to examine the clock waveform at pin 40 of *IC1*; its period should be roughly 1.6 microseconds.

If the reset and clock appear to be functioning properly but you still do not obtain a display, check the cable that connects the together the two circuit-board assemblies. Also, check to make sure the display module itself is operational. Measure all power supply potentials and check for incorrectly installed integrated circuits and LED numeric displays. Check particularly for jumper wires you forgot to install.

If you still have not isolated the problem, try testing or/and replacing *IC1*, *IC3*, *IC4*, *IC5*, *IC10*, *IC12*, *IC13*, *IC14*, *IC16* and *IC19* on the CPU module board and *IC109* and *IC110* on the display module board. (Other ICs on the display board affect only one decade of the display—not the entire display.)

### Coming Next Month

This completes checkout of the CPU and display/output modules and preliminary checkout of the basic system. Next month, we will describe in detail the two remaining modules that complete the stand-alone weather system—the A/D memory-expansion board and the keyboard—and give fabrication details for the SUN and LIGHT sensors. **ME**

## CD-Rom Reader

(from page 66)

lecting a battery pack to recommend for use with the unit.

Some people who should know better have winced at the nearly \$5,000 price tag, but they tend to forget that the Compaq SLT lacks a CD-ROM player and only adds a keyboard, yet costs several hundred dollars more for a machine that has nearly identical benchmarks.

At \$4,995 list price and an additional \$650 for the 20-MB hard disk, the complete hard disk version is still only about \$250 more than the Compaq, which is not a bad price for a half-height Hitachi CD-ROM drive! Moreover, aside from being able to extract up to 200,000 pages of text and graphics from a single CD-ROM, it doubles as a powerful computer. Add compactness and a peerless LCD screen display, and a touch-screen menu system and keyboard that simplifies operating, DynaBook represents an impressive combining of advanced technology.

For further information contact: Scenario, Inc., 235 Holland St., Somerville, MA 02144, 617-625-1818. **ME**

CIRCLE 73 ON FREE INFORMATION CARD

## ADVERTISERS' INDEX

RS#		Page #
53	AMC Sales	4
46	ARRL	7
24	All Electronics	81
-	B&B Inc.	78
75	C&S Sales	13
98	Cleveland Institute of Elec.	Cov. 111
-	Command Productions	75
71	Consolidated Electronics	63
148	Cook's Institute	4
41	Deco Industries	78
43	Digi-Key Corp.	79
23	Digital Research Computers	81
-	Electronics Book Club	3
16	Electron Processing Inc.	80
-	Grantham	31
45	Information Unlimited	63
25	Jan Crystals	28
95	Kenwood, USA	Cov. 1V
-	Listen Electronics	78
17	Midwest Electronics	78
-	NRI Schools	25
42	OptoElectronics	Cov. 11
-	Pacific Cable Co., Inc.	5
18	Parts Express International	11
-	Penn Research	80
-	Trans World Cable Co.	78
-	Video-Link Ent, Inc.	80
44	Viejo Publications	28
-	Visitec Inc.	80

We'd like to see your company listed here too. Contact Jonathan Kummer at 516-681-2922 to work out an advertising program tailored to suit your needs.

# EXPAND YOUR CAREER HORIZONS...

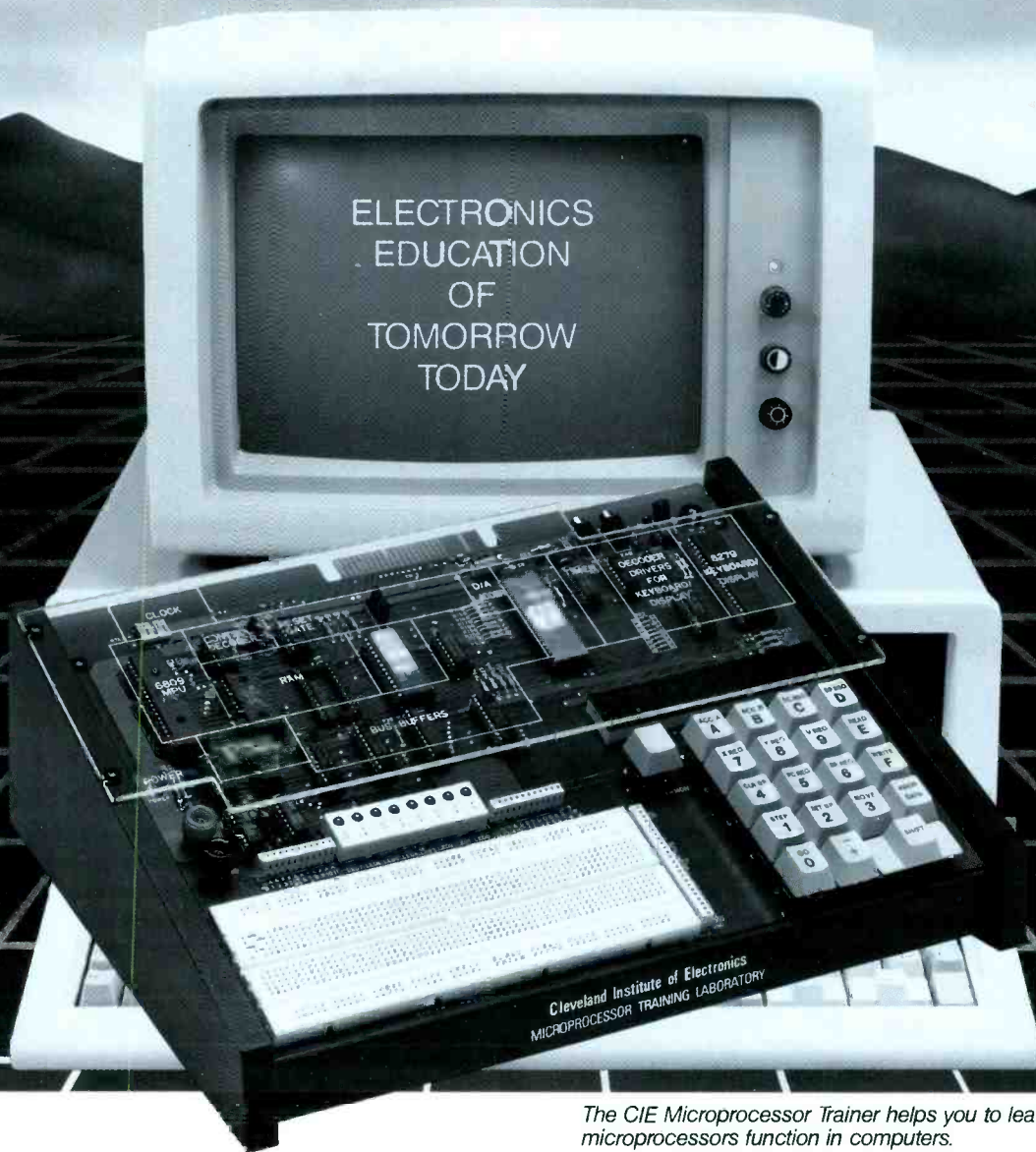

The CIE Microprocessor Trainer helps you to learn how circuits with microprocessors function in computers.

## START WITH CIE.

Microprocessor Technology. Satellite Communications. Robotics. Wherever you want to go in electronics... start first with CIE.

Why CIE? Because we're the leader in teaching electronics through independent study. Consider this. We teach over 25,000 students from all over the United States and in over 70 foreign countries. And we've been doing it for over 50 years, helping thousands of men and women get started in electronics careers.

We offer flexible training to meet your needs. You can start at the beginner level or, if you already know something about electronics, you may want to start at a higher level. But wherever you start, you can go as far as you like. You can even earn your Associate in Applied Science Degree in Electronics.

Let us get you started today. Just call toll-free 1-800-321-2155 (in Ohio, 1-800-362-2105) or mail in

the handy reply coupon or card below to:  
Cleveland Institute of Electronics,  
1776 East 17th Street, Cleveland, Ohio 44114.

**CIE** World Headquarters

AMO-145

**Cleveland Institute of Electronics, Inc.**  
1776 East 17th Street • Cleveland, Ohio 44114

Please send your independent study catalog.  
For your convenience, CIE will try to have a representative contact you — there is no obligation.

Print Name \_\_\_\_\_

Address \_\_\_\_\_ Apt. \_\_\_\_\_

City \_\_\_\_\_ State \_\_\_\_\_ Zip \_\_\_\_\_

Age \_\_\_\_\_ Area Code/Phone No. \_\_\_\_\_

Check box for G.I. Bill bulletin on Educational Benefits

Veteran  Active Duty **MAIL TODAY!**

Just call toll-free 1-800-321-2155 (in Ohio, 1-800-362-2105)



# KENWOOD

...pacesetter in Amateur Radio

**NEW**  
RZ-1 Wide-Band  
Receiver.

## Hear it All!



### R-5000

R-2000  
High performance  
receivers.

Scan the entire frequency range from 100 kHz to 905 MHz with Kenwood's R-5000, R-2000 and RZ-1. Listen in on foreign music, news, and commentary. Monitor local police, fire, and other public safety services, as well as the Marine channels, and the many other services 50 MHz and above.

(The VHF converter options must be used in the R-5000 and R-2000.)

### R-5000

The R-5000 is a high performance, top-of-the-line receiver, with 100 memory channels, and direct keyboard or manual tuning—makes station selection



### R-2000

The R-2000 is an all band, all mode receiver with 10 memory channels and many deluxe features such as programmable scanning, dual 24-hour clocks with timer all-mode squelch and noise blankers, a large, front-mounted speaker, 110 volt AC or 12 volt DC operation (with the DCK-1 cable kit), and 118-174 MHz VHF capability with VC-10 option.

#### Optional Accessories

##### R-2000:

- VC-10 VHF converter • DCK-1 DC cable kit for 12 volt DC use.

##### R-5000:

- VC-20 VHF converter • VS-1 Voice module • DCK-2 for 12 volt DC operation
- YK-88A-1 AM filter • YK-88SN SSB filter • YK-88C CW filter • MB-430 Mounting bracket.

#### Other Accessories:

- SP-430 External speaker • SP-41 Compact mobile speaker • SP-50B Mobile speaker • HS-5 Deluxe headphones • HS-6 Lightweight headphones • HS-7 Mini-headphones.

super easy! Other useful features include programmable scanning, large, built-in speaker, 110 volt AC or 12 volt DC operation (with optional DCK-2 cable), VHF capability (108-174 MHz) with the VC-20 option, dual 24-hour clocks with timer, and even voice frequency readout with the VS-1 option.

### RZ-1

Wide-band scanning receiver



The RZ-1 wide-band scanning receiver covers 500 kHz-905 MHz, in AM, and narrow or wideband FM. The automatic mode selection function makes listening

easier. One hundred memory channels with message and band marker, direct keyboard or VFO frequency entry, and versatile scanning functions, such as memory channel and band scan, with four types of scan stop. The RZ-1 is a 12 volt DC operated, compact unit, with built-in speaker, front-mounted phones jack, switchable AGC, squelch for narrow FM, illuminated keys, and a "beeper" to confirm keyboard operation.

- Optional Accessory**
- PG-2N Extra DC cable

# KENWOOD

KENWOOD U.S.A. CORPORATION  
2201 E. Dominguez St., Long Beach, CA 90810  
P.O. Box 22745, Long Beach, CA 90801-5745

Specifications, features, and prices are subject to change without notice or obligation

NO. 95 ON FREE INFORMATION CARD