

ICD 08559

NOVEMBER 1988 \$2.50
CANADA \$3.50

MODERN ELECTRONICS™

THE MAGAZINE FOR ELECTRONICS & COMPUTER ENTHUSIASTS

- **High-Speed CMOS: Logic Circuit Designing**
- **Light-Sensor Device Shows Operating Status of All Computer Equipment**



- Full-Construction Plans:**
- **Car Windshield-Washer Level Indicator**
 - **Device Warns Extension-Phone User When Modem Operates on Same Line**
 - **Ignition-Problem Simulator Thwarts Vehicle Thieves**

- For the Holidays:**
- **High-Tech Greeting Card**
 - **Programmable Light Sequencer Creates Dramatic Displays**

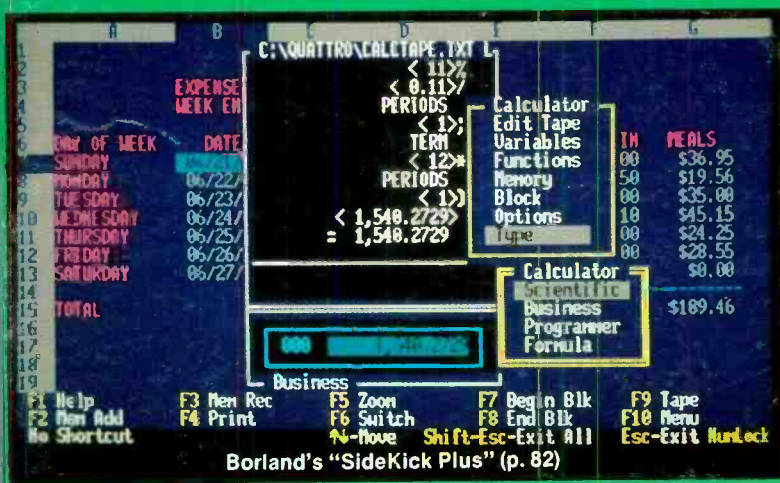

Plus: Adding Signal-Tracing & Signal-Injection Capabilities to the Semianalyzer
 ● Forrest Mims on Learning From Electronic Experimenting Failures ●
 Switched-Capacitor Filter ICs ● Electronics-Oriented Computer Bulletin Boards
 ● Evaluating Borland's newest "SideKick" ● Computer Data Backing Up &
 Benchmarking ● Electronics & Computer News ● Latest Books & Literature ... more.

Fordham measures up

Quality • Price • Delivery

Mini-Meters with Maxi-Specs



SCOPE 3 1/2 Digit LCD Meter

- 0.5% Accuracy • DC Voltage • AC Voltage • DC Current • Resistance • Diode Test • Battery Life 300 Hrs. • Overload Protection: DC 500V, AC 350V, ohms 250V DC/AC.

Model DVM-630 **\$2995**
Our Price

Zippered carrying case CC-30 \$4.50

NEW! SCOPE 3 1/2 Digit, LCD 8 Function with Transistor Tester

- 0.5% Accuracy • Audible continuity and diode test • 10 Amp measurement • Resistance • DC/AC Voltage.

Model DVM-632 **\$4495**
Reg. \$60.00 Our Price

Zippered carrying case CC-30 \$4.50

SCOPE 3 1/2 Digit LCD with Autoranging

- 0.5% Accuracy • Auto/Manual range selection • DC Voltage • AC Voltage • AC Current • DC Current • Resistance.

Model DVM-631 **\$4995**
Our Price

Special

Deluxe carrying case CA-92 \$9.95

SCOPE Hand-Held Digital Multimeters

- Overload protection • Auto-decimal LCD readout • Polarity indication • 300 hr. 9V battery life • Low battery indicator.

- 8 Function, 37 ranges including Transistor and Capacitance measurements

Model DVM-636 **\$6750**
Our Price



CA-92 Deluxe Padded Case for DVM meters. \$9.95
TL-216 Transistor and Capacitance Test Leads \$9.90

- 11 Function, 38 ranges including Logic Level Detector, Audible and Visual Continuity, Capacitance and Conductance measurements

Model DVM-638 **\$8750**
Our Price



- NEW!**
SCOPE Frequency Counters
- 8-digit LED • Compact • lightweight
 - High performance • Automatic range and Hold function • High stability in reference oscillator.

Model FC-7011 **\$14995**
100 MHz Our Price

Model FC-7051 **\$19995**
550 MHz Our Price



- FORDHAM Frequency Counter**
- 10 Hz - 150 MHz Range • 7-digit LED display • VHF/HF selection
 - Gate time 1 sec., 5 sec. • ±1 count accuracy.

Model FC-150 **\$13990**
Our Price



NEW FORDHAM Function Generator

- 0.5 Hz - 500 KHz in 6 ranges • Sine, square & triangle wave forms • VCA and VCF inputs • Accuracy ±5% of full scale.

Model FG-202 **\$14990**
Our Price



FORDHAM Signal Tracer/Injector

- Easy to operate • VU meter • Two LED mode indicators • 1 KHz test tone • 8 ohm speaker • Test leads.

Model SE-610 **\$11990**
Our Price



FORDHAM LCR Bridge Meter

- Fully transistorized • 1 KHz signal generator • Measures resistance
- Inductance • High mechanical and electrical stability • Battery operated.

Model LC-340 **\$14995**
Our Price



SCOPE Digital Capacitance Meter

- Digital LCD display • LSI-circuit • High accuracy: 100 ppm 0.5% • Broad test range • Fast sampling time • Capacitor discharge protection • Compact, lightweight design • One-hand operation.

Model DCM-602 **\$5995**
Our Price

Telephone Orders Now!

EVERYDAY INCLUDING SATURDAY
Mon. - Fri. 8 a.m. - 6:30 p.m. EST. Sat. & Sun. 9 a.m. - 3 p.m. EST

ASK FOR FREE CATALOG. Money orders, checks accepted. C.O.D.'s require 25% deposit



Fordham

260 Motor Parkway, Hauppauge, NY 11788

Toll Free **800-645-9518**

In NY State 800-832-1446

Service & Shipping Charge Schedule Continental U.S.A.

FOR ORDERS	ADD
\$25-50	\$4.50
\$51-100	\$5.50
\$101-200	\$7.00
\$201-300	\$8.00
\$301-400	\$9.00
\$401-500	\$10.00
\$501-750	\$12.50
\$751-1000	\$15.00
\$1,001-1,250	\$17.50
\$1,251-1,500	\$20.00
\$1,501-2,000	\$25.00
\$2,001 and up	\$30.00

Your Career in *ELECTRONICS* or *COMPUTERS*

Add prestige and earning power to your technical career by earning your Associate or Bachelor's Degree in electronics or computers—through independent home study.

No commuting to class. Study at your own pace, while continuing on your present job. Learn from easy-to-understand lessons, with help from your Grantham instructors when you need it.

Grantham College of Engineering is a specialized institution catering to adults who are employed in electronics and allied fields such as computers. These fields are so enormous that opportunity for advancement is always present. Promotions and natural turn-over make desirable positions available to those who are *prepared to move up!*

Put Professional Knowledge and a
COLLEGE DEGREE
in your Technical Career through
HOME STUDY

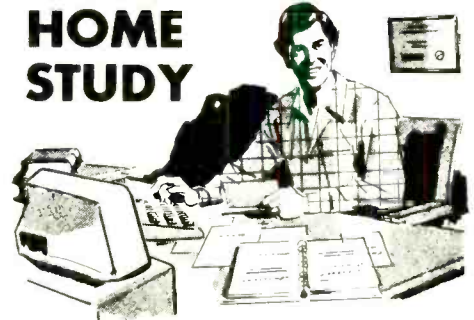

Accredited by the
Accrediting Commission of the National Home Study Council

Grantham College of Engineering
10570 Humbolt Street
Los Alamitos, California 90720

Write for our free catalog
(see coupon below) or phone
(213) 493-4423 (no collect calls)
and ask for our "degree catalog."

Grantham offers two B.S. degree programs — one with major emphasis in **ELECTRONICS** and the other with major emphasis in **COMPUTERS**. Either program can be completed by correspondence (also known as "distance education.") An A.S. degree is awarded along the way in each B.S. program, but the B.S. program is not complete without the A.S. part. Our catalog gives complete details.

Now in Our
38th Year

Grantham College of Engineering
has conferred on
John Doe
the degree of
Associate in Science in Engineering Technology
with major emphasis in Computers

Grantham College of Engineering
has conferred on
John Doe
the degree of
Bachelor of Science in Engineering Technology
with major emphasis in Computers
In witness thereof, this diploma duly signed has been issued by the College Administration upon recommendation of the Faculty, at the College in

Grantham College of Engineering
has conferred on
John Doe
the degree of
Associate in Science in Engineering Technology
with major emphasis in Electronics

Grantham College of Engineering
has conferred on
John Doe
the degree of
Bachelor of Science in Engineering Technology
with major emphasis in Electronics
In witness thereof, this diploma duly signed has been issued by the College Administration upon recommendation of the Faculty, at the College in Los Alamitos, California, on this day of March 1, 1987.

D.J. Grantham President
H. L. Perry Dean

Grantham College of Engineering
P.O. Box 539, Los Alamitos, CA 90720

Please mail me your free catalog which explains your distance-education degree programs.

NAME _____

ADDRESS _____

CITY _____ STATE _____ ZIP _____

M-1188

FEATURES



22

16 High-Speed CMOS: The Best of Both Worlds

Low power consumption and high noise immunity of CMOS, with speed and drive capability of LSTTL.
By Jan Axelson

22 Electronic Greeting Card

Flashing LEDs and colorful electronic "ornaments" give this different kind of holiday greeting card a high-tech look. *By Lee Hart*

32 Photo Sensor Operating Status Indicator

Centralizes visible/audible status indication of separate components in a system without electrical connections. *By Adolph A. Mangieri*

37 Car Windshield-Washer Low-Level Indicator

Tells you when washer fluid is getting low in ample time to replenish it. *By Charles Shoemaker, Ph.D.*

44 Vehicle Anti-Theft Device

Simulates ignition problem when a thief tries to drive away your car. *By Anthony J. Caristi*

49 Phone-Line "Busy" Indicator

Lights a LED to inform extension users that you are using your modem. *By Robert M. Harkey*

50 Programmable Light Controller (Part 1)

Illumination "computer" can be programmed to enhance holiday light displays with sophisticated sequencing, flashing, twinkling effects. *By David Miga*

56 Semianalyzer Revisited

Add signal-tracing and signal-injection capabilities to this versatile instrument. *By David Miga*

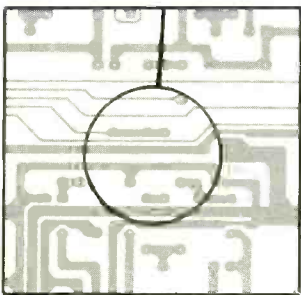

56

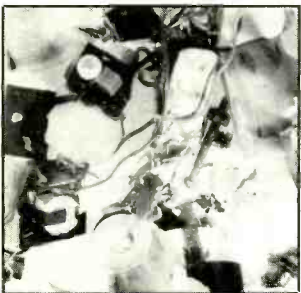

61

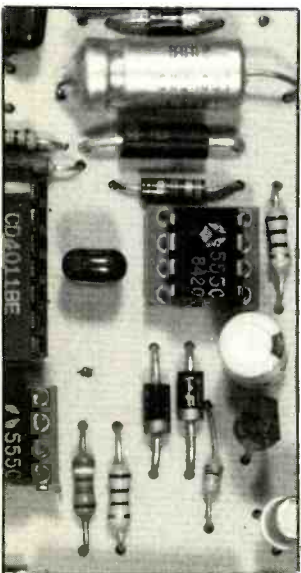

44

COLUMNS

61 Electronics Notebook

Learning from Failure. *By Forrest M. Mims III*

66 Solid-State Devices

Switched-Capacitor Filter ICs & LED Replacements for Incandescent Lamps. *By Harry L. Helms*

72 Electronics Omnibus

Electronics-Oriented BBS's. *By Curt Phillips*

78 PC Capers

Backing Up & Benchmarking. *By Ted Needleman*

82 Software Focus

Borland's "SideKick Plus." *By John McCormick*

DEPARTMENTS

4 Editorial

By Art Salsberg

5 Letters

6 Modern Electronics News

8 New Products

88 Books & Literature

96 Advertisers Index

EDITORIAL STAFF

Art Salsberg
Editor-in-Chief

Alexander W. Burawa
Managing Editor

Dorothy Kehrwierd
Production Manager

Elizabeth Ryan
Art Director

Barbara Scully
Artist

Pat Le Blanc
Florence V. Martin
Phototypographers

Hal Keith
Illustrator

Bruce Morgan
Photographer

Leonard Feldman, Harry Helms,
Forrest Mims III, Ted Needleman,
Curt Phillips
Contributing Editors

BUSINESS STAFF

Richard A. Ross
Publisher

Art Salsberg
Associate Publisher

Dorothy Kehrwierd
General Manager

Frank V. Fuzia
Controller

Arlene Caggiano
Accounting

Catherine Ross
Circulation Director

SALES OFFICES

Modern Electronics
76 North Broadway
Hicksville, NY 11801
(516) 681-2922

Advertising Manager
Peter Conn

Sales Assistant
Kathleen O'Lenahan

76 North Broadway
Hicksville, NY 11801
(516) 681-2922

Offices: 76 North Broadway, Hicksville, NY 11801. Telephone: (516) 681-2922. FAX (516) 681-2926. Modern Electronics (ISSN 0748-9889) is published monthly by CQ Communications, Inc. Application to mail at second class rates pending at Hicksville, NY and other points. Subscription prices (payable in US Dollars only): Domestic—one year \$17.97, two years \$33.00, three years \$48.00; Canada/Mexico—one year \$20.00, two years \$37.00, three years \$54.00; Foreign—one year \$22.00, two years \$41.00, three years \$60.00. Foreign Air Mail—one year \$75.00, two years \$147.00, three years \$219.00.

Entire contents copyright 1988 by CQ Communications, Inc. Modern Electronics or CQ Communications Inc. assumes no responsibility for unsolicited manuscripts. Allow six weeks for delivery of first issue and for change of address. Printed in the United States of America. Postmaster: Please send change of address notice to Modern Electronics, 76 North Broadway, Hicksville, NY 11801.

pending on the nature of work that's being done.

The motivation for working for profit at home takes many forms. It could well be the route taken to kick off a new business part time while holding a full-time job elsewhere. It could be a link with the home office through a computer modem. And it could be a way to increase your income part-time, or a full-time venture that uses the home to reduce overhead expense and enhance work efficiency by eliminating travel time to and from work or by just being able to work at an odd hour any time you please.

Whatever the case, the home office or shop is evidently here to stay and shows all signs of rapid growth. With the aid of electronic and computer devices, it has become more convenient to do than ever before.

Art Salsberg

Some authors supply parts as a service to readers who may not be able to find suppliers, especially if they're hard-to-find items like specialty integrated circuits. In other cases, like the ones you cite, the parts are offered as a convenience without requiring a minimum-order price. It's true that in some instances you'll do a lot better with the big boys, so read the ads and make your judgment.—Ed.

Address Change

• Readers who wish to purchase my Digital Measuring System and its accessory modules should be advised that there has been an address change for mail orders. The new address to which to send orders is BALLco, P.O. Box 1078, Snellville, GA 3024.

Charles R. Ball

CABLE-TV

WE'LL MATCH OR BEAT ANYONE'S ADVERTISED RETAIL OR WHOLESALE PRICES!

BONANZA!

ITEM	1 UNIT	10 OR MORE
HAMLIN MCC 3000 36 CORDED REMOTE CONVERTER (Ch 3 only)	29.00	18.00
PANASONIC WIRELESS CONVERTER (our best buy)	98.00	79.00
MOVIE TIME VR7200A (manual fine tune)	88.00	69.00
*JERROLD 400 COMBO	169.00	119.00
*JERROLD 400 HAND REMOTE CONTROL	29.00	18.00
*JERROLD 450 COMBO	199.00	139.00
*JERROLD 450 HAND REMOTE CONTROL	29.00	18.00
*JERROLD SB-ADD-ON	99.00	63.00
*JERROLD SB-ADD-ON WITH TRIMODE	109.00	75.00
*M-35 B COMBO UNIT (Ch 3 output only)	99.00	70.00
*M-35 B COMBO UNIT WITH VARISYNC	109.00	75.00
*MINICODE (N-12)	99.00	62.00
*MINICODE (N-12) WITH VARISYNC	109.00	65.00
*MINICODE VARISYNC WITH AUTO ON-OFF	145.00	105.00
ECONOCODE (minicode substitute)	69.00	42.00
ECONOCODE WITH VARISYNC	79.00	46.00
*MLD-1200-3 (Ch 3 output)	99.00	62.00
*MLD-1200-2 (Ch 2 output)	99.00	62.00
*ZENITH SSAVI CABLE READY	175.00	125.00
INTERFERENCE FILTERS (Ch 3 only)	24.00	14.00
*EAGLE PID-3 DESCRAMBLER (Ch 3 output only)	119.00	65.00
*SCIENTIFIC ATLANTA ADD-ON REPLACEMENT DESCRAMBLER	119.00	85.00

*CALL FOR AVAILABILITY

Quantity	Item	Output Channel	Price Each	TOTAL PRICE

California Penal Code #593-D forbids us from shipping any cable descrambling unit to anyone residing in the state of California. Prices subject to change without notice.

SUBTOTAL
Shipping Add \$3.00 per unit
COD & Credit Cards — Add 5%
TOTAL

PLEASE PRINT

Name _____
 Address _____ City _____
 State _____ Zip _____ Phone Number () _____
 Cashier's Check Money Order COD Visa Mastercard
 Acct # _____ Exp. Date _____
 Signature _____

FOR OUR RECORDS:

DECLARATION OF AUTHORIZED USE — I, the undersigned, do hereby declare under penalty of perjury that all products purchased, now and in the future, will only be used on cable TV systems with proper authorization from local officials or cable company officials in accordance with all applicable federal and state laws. FEDERAL AND VARIOUS STATE LAWS PROVIDE FOR SUBSTANTIAL CRIMINAL AND CIVIL PENALTIES FOR UNAUTHORIZED USE.

Dated: _____ Signed: _____

© Copyright 1987 PACIFIC CABLE CO., INC.

Pacific Cable Company, Inc.

7325½ RESEDA BLVD., DEPT. #ME • RESEDA, CA 91335
 (818) 716-5914 • No Collect Calls • (818) 716-5140

IMPORTANT: WHEN CALLING FOR INFORMATION
 Please have the make and model # of the equipment used in your area. Thank You

EQUIPMENT MAKERS AID DISABLED. President Reagen signed into law the Hearing Aid Compatibility Act of 1988 last August, mandating that all new residential and business telephone in the U.S. be hearing-aid compatible. Phone makers have a one-year transition period to comply with the new law for corded telephones and three years for cordless ones. One manufacturer, GTE, already complies since all its current phone models are hearing-aid compatible....Radio Shack now offers a variety of adaptive devices for computer users with special needs. Among the devices is an alternative keyboard that has a tough flat panel with 128 large, touch-sensitive and user-definable keys or "squares" that allow full computer use with one finger. The company also has a number of ability switches to help users with limited or uncontrollable limb movement to enter information into a Tandy computer without relying on a keyboard. One such product, a Pneumatic Dual Switch, is operated by oral control or puffing and sipping on the switch.

VIDEO & AUDIO HAPPENINGS. TV watchers could be observing programs recorded on video tape or on film, each having its proponents among producers (film lends itself to more artistic work, while video is more efficient to use). Until now, they couldn't work easily with both media interchangeably because they operate at different frame rates (24 frames/sec. for film; 30 frames/sec. for video). CMX Corp., however, has developed a computer software technique called MC² (Matched Computer Cut) that allows editors to prepare both a film cut and videotape master, including each one's audio, and have them be accurately frame matched. As a result, it's now easier to shoot on film, edit on video tape and release prints on both media that are essentially identical....A new Beolink handheld infra-red remote-control system by Bang & Olufsen integrates audio and video and distributes them to as many as 16 different rooms in a home, along with control of a home's lighting. All from any room....Among the interesting instructional videocassette tapes that recently debuted is "The Cable TV/VCR Hook-Up Guide" from Naczinski & Associates, Inc. (Los Angeles, CA. Called H.U.G. for Hook-Up Guide, it provides simple instructions on how to make various connections to record one cable channel while watching another on video. The tape comes with a Ready Reference Slide Card that provides quick answers to cable TV/VCR operation and peel I.D. Labels, as well as a \$10 HBO/Cinemax Rebate Coupon (for a limited time). The 60-minute program has a suggested retail price of \$24.95. Consumer toll-free number is 1-800-523-5503....Home Broadcast Network (HBN) released its first episode of GOLFER, a new monthly "video periodical." The 70-minute tape features golf legend Sam Snead, among other celebrities and instructors in golf. This one covers a golf outing to Scotland's St. Andrews Golf Course. The tapes are available by a 12-month subscription for \$9.95/month. National retail chains will be selling them for \$14.95 each. The network plans to introduce similar videocassettes on driving for car enthusiasts and hunting and fishing, among others planned. Production costs are said to be \$350,000 per episode. Tapes are available in VHS and 8mm formats. Call 800-346-1320, ext. 101.

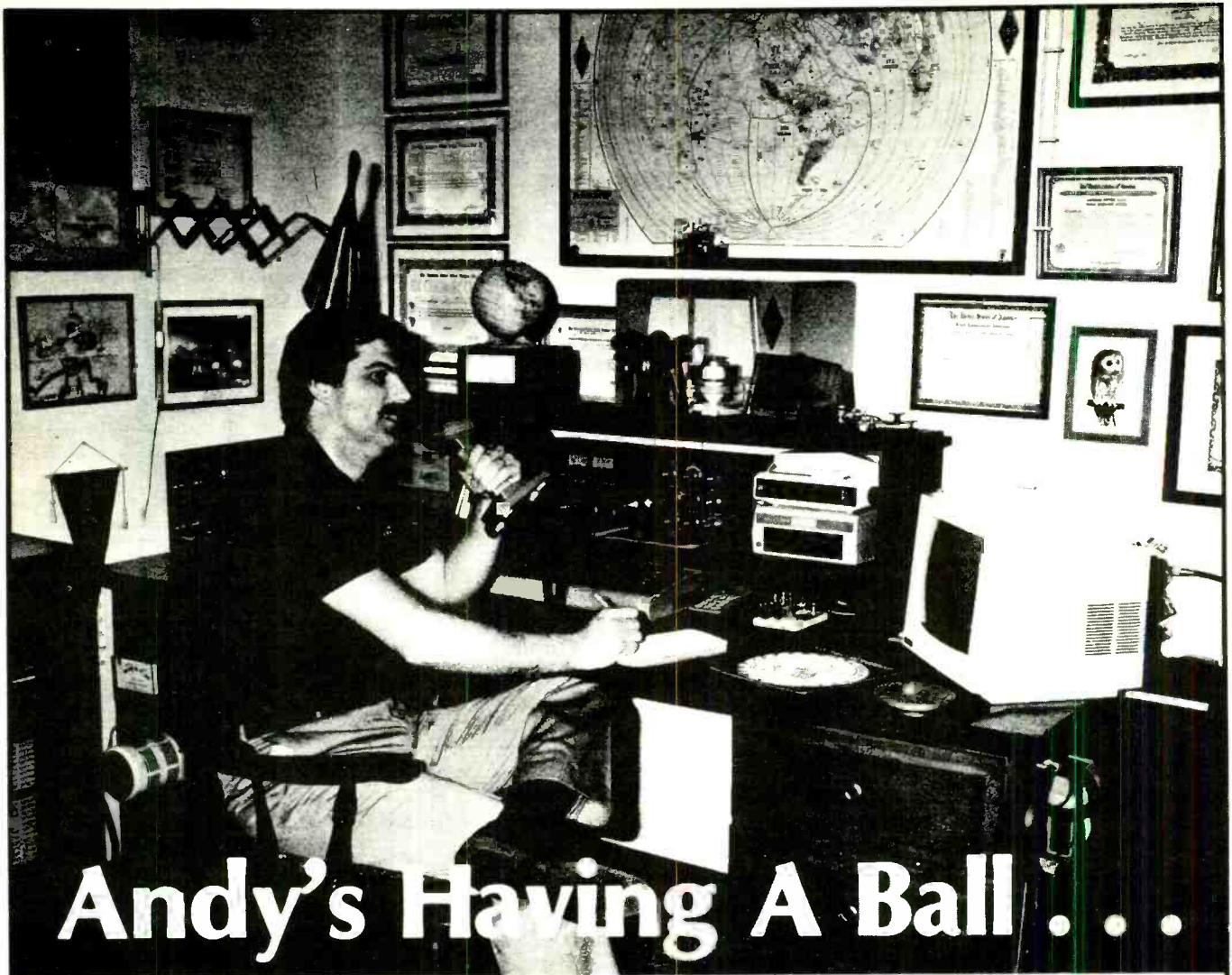

Andy's Having A Ball . . .

and you can too!

Andy is a Ham Radio operator and he's having the time of his life talking to new and old friends in this country and around the world.

You can do it too! Join Andy as he communicates with the world. Enjoy the many unique and exclusive amateur bands . . . the millions of frequencies that Hams are allowed to use. Choose the frequency and time of day that are just right to talk to anywhere you wish. Only Amateur Radio operators get this kind of freedom of choice. And if it's friends you're looking to meet and talk

with, Amateur Radio is the hobby for you. The world is waiting for you.

If you'd like to be part of the fun . . . if you'd like to feel the excitement . . . we can help you. We've got all the information you'll need to get your Ham license. Let us help you join more than a million other Hams around the world and here at home. Who are we? We're the American Radio Relay League, a non-profit representative organization of Amateur Radio operators.

For information on becoming a Ham operator
circle number 110 on the reader service card or write to:

AMERICAN RADIO RELAY LEAGUE

Dept CQ, 225 Main Street
Newington, Conn. 06111.

For more information on products described, please circle the appropriate number on the Free Information Card bound into this issue or write to the manufacturer.

Sweep/Function Generators

Two new sweep/function generators are now being offered by Simpson Electric Co. The Models 421 and 422 provide front-panel selection of sine, square and triangle waveform outputs. Sweep frequencies have selec-

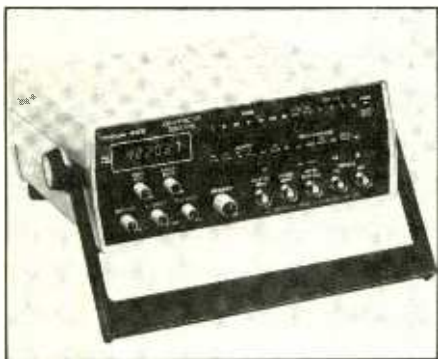

table start/stop ranges, with 100:1 linear and 1,000:1 logarithmic sweep ratios. These sweep ranges can be set at any two points within the 0.5-Hz to 5-MHz range of operation. Sweep time can range from 0.05 to 30 seconds. The TTL output is designed to drive up to 10 loads with 25-ns rise/fall time for precise measurement and testing of logic and digital circuits. Outputs are 10 volts peak-to-peak into 50 ohms, 20 volts peak-to-peak into 1 megohm.

Though the two models are basically the same, the Model 422 features a 6-digit LED display that can function as an internal/external-reading frequency counter. Also, output and sweep start/stop frequencies can be set with the Model 422's digital display. Both instruments feature free-running, external-trigger (TTL input) and manual trigger modes. Output amplitude is continuously variable over a greater than 30 dB range, with fixed 0 to 30 dB attenuation.

Technical specifications: dial ac-

curacy (Model 421), $\pm 10\%$ full-scale; counter accuracy (Model 422), ± 1 count ± 10 ppm \times frequency; sine-wave distortion, less than 1% 0.5 Hz to 100 kHz at 10 V p-p into 50 ohms; harmonic distortion, better than -24 dB 100 kHz to 5 MHz; triangle-wave nonlinearity/nonsymmetry, less than 1% up to 100 kHz; square-wave rise/fall time, less than 100 ns (60 ns typical); square-wave nonsymmetry, less than 1% up to 100 kHz; TTL output rise/fall time, 25 ns; output impedance, 50 ohms $\pm 5\%$; amplitude flatness, ± 0.1 dB up to 20 kHz, ± 0.3 dB all other frequencies (sine wave); 10.5"D \times 9.875"W \times 3.9"H; 4.25 lbs. \$535 Model 421, \$650 Model 422.

CIRCLE 78 ON FREE INFORMATION CARD

Computer Theft Deterrent

"Thiefbug" from CEPCO (Canoga Park, CA) is designed to protect computers, office equipment and other electronic devices from theft and unauthorized removal. It installs inside the electrical outlet box into which the equipment to be protected is plugged, where it will not be seen. The device detects when the item is disconnected (unplugged or has its power cord cut) and uses existing ac

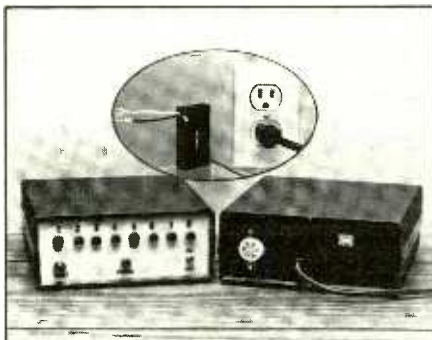

power wiring to transmit a coded alarm signal that gives its location to a remote monitoring unit.

The monitoring units require no wiring and plug directly into a 117-volt ac outlet. They monitor as many Thiefbugs as may be required in a given installation. These monitoring

units range from a single plug-in buzzer to wall-mounted monitoring panels that annunciate up to 512 zones (locations in which an electrical device is being protected). They provide audible, visual and electronic (relay) outputs.

CIRCLE 79 ON FREE INFORMATION CARD

Hand-Held Transceiver

Fanon Courier's Procom 2-watt, hand-held business-band transceiver is claimed to have a range of better than 2 miles. This single-channel, professional-quality unit offers a choice of one of three frequencies.



Each comes with one set of installed crystals for 151.625 MHz (Frequency A), 154.570 MHz (Frequency B) or 154.600 MHz (Frequency C). Included with the transceiver is a rechargeable Ni-Cd battery pack, ac battery charger, flexible antenna and FCC license application.

Features include an adjustable squelch control with tone squelch on/off switch, volume control with power switch, and jacks for the battery charger and external antenna. Housed in sturdy high-impact textured plastic case, the Procom weighs about 1 pound and measures 7"H \times 2½"W \times 1¾"D.

5 sure steps to a fast start as a high-paid computer service technician

1. Choose training that's right for today's good jobs

Jobs for computer service technicians will almost double in the next 10 years, according to the latest Department of Labor projections. For you, that means unlimited opportunities for advancement, a new career, or even a computer service business of your own.

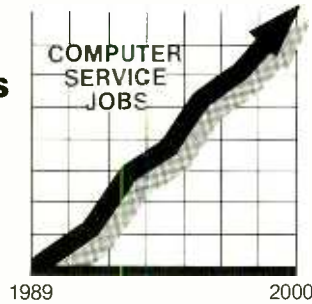

But to succeed in computer service today, you need training—complete, practical training that gives you the confidence to service any brand of computer. You need NRI training.

Only NRI—the leader in career-building, at-home electronics training for 75 years—gives you practical knowledge, hands-on skill, and real-world experience with a powerful XT-compatible computer you keep. Only NRI starts you with the basics, then builds your knowledge step by step until you have everything you need for a fast start as a high-paid computer service technician.

computer while giving you lightning-quick data access

By getting inside this powerful computer, you get the confidence-building, real-world experience you need to work with, troubleshoot, and service today's most widely used computer systems.



2. Go beyond "book learning" to get true hands-on experience

NRI knows you learn better by doing. So NRI training works overtime to give you that invaluable practical experience.

You first read about the subject,

studying diagrams, schematics, and photos that make the subject even clearer. Then you do. You build, examine, remove, test, repair, replace. You discover for yourself the feel of the real thing, the confidence gained only with experience.

3. Get inside a powerful computer system

If you really want to get ahead in computer service, you have to get inside a state-of-the-art computer system. That's why NRI includes the powerful new Packard Bell VX88 computer as the centerpiece of your hands-on training.

As you build this fully IBM PC XT-compatible micro from the keyboard up, performing key tests and demonstrations at each stage of assembly, you actually see for yourself how every section of your computer works.

You assemble and test your computer's "intelligent" keyboard, install the power supply and 5¼" floppy disk drive, then interface the high-resolution monitor. But that's not all.

You go on to install a powerful 20 megabyte hard disk drive—today's most-wanted computer peripheral—included in your training to dramatically increase the data storage capacity of your

4. Make sure you've always got someone to turn to for help



Throughout your NRI training, you've got the full support of your personal NRI instructor and the entire NRI technical staff. Always ready to answer your questions and help you if you should hit a snag, your instructors will make you feel as if you're in a classroom of

one, giving you as much time and personal attention as you need.

5. Step into a bright new future in computer service—start by sending for your FREE catalog today!

Discover for yourself how easy NRI makes it to succeed in computer service. Send today for NRI's big, 100-page, full-color catalog describing every aspect of NRI's one-of-a-kind computer training, as well as training in robotics, TV/video/audio servicing, electronic music technology, security electronics, and other growing high-tech career fields.

If the coupon is missing, write to: NRI School of Electronics, McGraw-Hill Continuing Education Center, 3939 Wisconsin Avenue, Washington, DC 20016. IBM is a registered trademark of International Business Machines Corp.



NRI School of Electronics

McGraw-Hill Continuing Education Center
3939 Wisconsin Avenue Washington, DC 20016

For career courses approved under GI Bill
 check for details.

- CHECK ONE CATALOG ONLY
- | | |
|--|--|
| <input type="checkbox"/> Computers and Microprocessors | <input type="checkbox"/> Security Electronics |
| <input type="checkbox"/> Robotics | <input type="checkbox"/> Electronic Music Technology |
| <input type="checkbox"/> TV/Video/Audio Servicing | <input type="checkbox"/> Digital Electronics Servicing |
| <input type="checkbox"/> Communications Electronics | <input type="checkbox"/> Data Communications |
| | <input type="checkbox"/> Basic Electronics |

Name _____

Address _____

City _____ State _____ Zip _____

Accredited by the National Home Study Council

4-118

High-Speed CMOS: The Best of Both Worlds

Offers the low power consumption, high noise immunity of CMOS and the speed and drive capability of LSTTL

By Jan Axelson

An essential step in designing a logic circuit is deciding upon which IC family to use. This usually means a choice between TTL and CMOS technologies, each of which has its own advantages and disadvantages.

TTL devices have long been familiar to circuit designers and are readily available from a host of suppliers. During the past few years, however, there has been a growing shift away from TTL toward CMOS as the designer's technology of choice. This is due to the low power consumption, wide power-supply voltage range and high immunity to noise that characterize CMOS devices. The popular 4000 series of CMOS devices offers these benefits—but not without some tradeoffs.

To obtain highest operating speed and maximize noise immunity, 4000-series CMOS requires a 9- to 15-volt power supply, which may not be as conveniently available as the 5-volt supplies used to power TTL circuits. This is certain to change as CMOS becomes more firmly established. Be aware, though, that even at higher operating voltages, 4000-series CMOS devices are relatively slow performers, with propagation delays averaging several times those of TTL.

In comparison with TTL devices, CMOS devices have a low output drive capability. Also, circuit designers who have become familiar with TTL devices will have to learn a

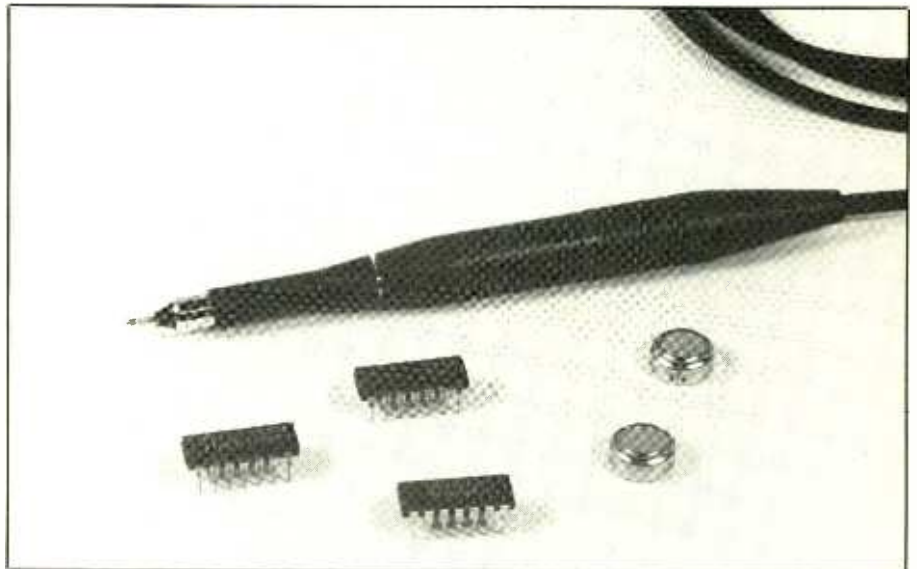

whole new set of identification numbers and pinout arrangements for CMOS devices. You can eliminate the last by choosing devices from the 74C CMOS family, which follows TTL numbering and pinouts, though these devices also are relatively slow and have low output drive.

The newer HC, or High-speed CMOS, family of logic chips overcomes these limitations, while offering advantages that aren't available in other individual logic families. In this article, we'll introduce you to high-speed CMOS and show you how to use it and take advantage of its capabilities.

Improved HC Technology

High-speed CMOS has the low pow-

er consumption and high noise immunity that typifies CMOS-technology IC devices. This family of logic elements includes devices that follow the numbering system and have the functions and pinouts of TTL. Just about every function available in TTL is now available in high-speed CMOS, including gates, flip-flops, counters, decoders/encoders and more. Additionally, HC devices are available with functions formerly found only in 4000-series CMOS, such as the popular 4066 analog switch (in the HC family, it's the 74HC4066).

Figure 1 shows how HC devices "match" familiar ICs from other families. Other functions, such as the 74HC943 modem chip, are unique to the HC family.

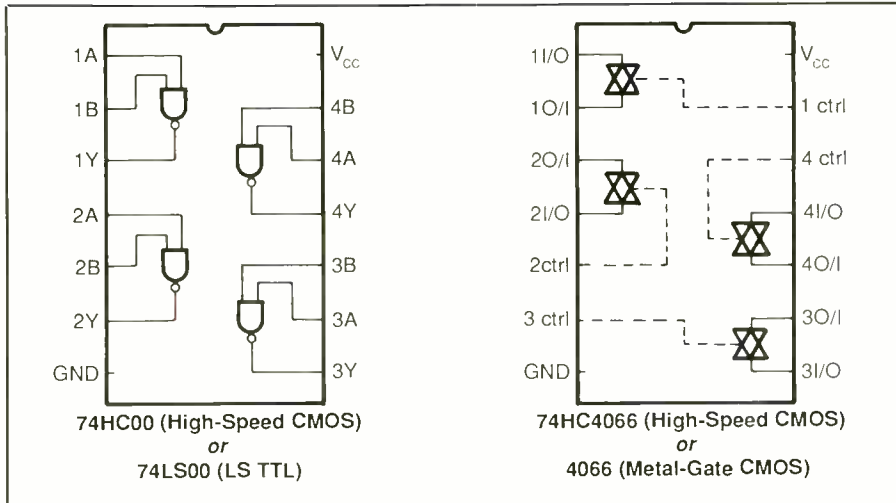

Fig. 1. Many HC devices, like the 74HC00 quad NAND gate, follow the same numbering scheme and pinouts as TTL devices. Others, like the 74HC00 quad bilateral switch, duplicate functions and pinouts of 4000-series CMOS devices.

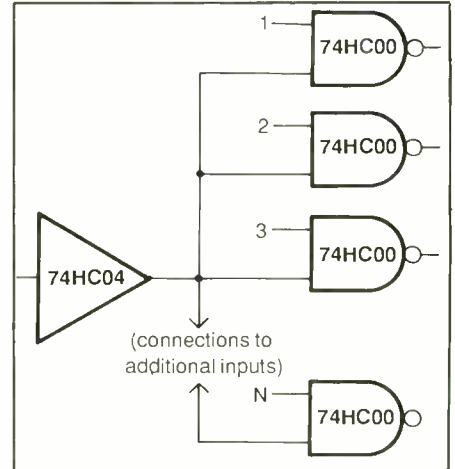

Fig. 2. Fanout from an HC output to HC inputs is virtually unlimited. Here output of 74HC04 inverter fans out to series of NAND inputs.

High-speed CMOS has been made possible through improved manufacturing technologies. The transistors in HC devices use 3-micron polysilicon gates, rather than the 7-micron metal gates used in 4000-series CMOS. In addition, overlap be-

tween the gate and source and drain areas is minimized due to a "self-aligned" gate process.

These and other improvements provide increased gain while at the same time reducing unwanted parasitic capacitances (the unavoidable capacitance due to the IC's structure). The result is devices with high operating speed as well as low power consumption.

Electronics experimenters will be gratified to learn that there are plenty of sources for HC devices in small (as well as large) quantities. Many manufacturers—including Texas Instruments, RCA, National Semiconductor and Motorola—now offer HC devices, and publish data books giving application notes and complete specifications.

Prices are comparable to, and sometimes lower than, those for LSTTL and 4000-series CMOS. Table I lists a few of the many mail-order suppliers who have added high-speed CMOS to their inventories.

Power Consumption

Table II summarizes the features and operating characteristics of the devices in the high-speed CMOS logic category.

Power-supply voltage range for CMOS devices is wide. Supplies that can deliver anywhere from 2 to 6 volts are recommended, but absolute maximum must be 7 volts. With a minimum of 2 volts at the low end, CMOS devices are ideal for low-voltage operation, such as 3 volts from two AA (or AAA) cells in series, or even small button-type cells.

Quiescent power consumption (power consumed when all inputs are tied to V_{cc} or ground and outputs are open) is trivial at only 25 microwatts per gate. Like other CMOS devices, HC devices consume power only when switching. The higher the operating frequency, the more transitions there are, and the greater the power consumption.

Even at the highest frequencies, power consumption of HC devices doesn't equal that of standard 74LS ("LS" stands for "low-power Schottky") TTL devices until they're operating at several megahertz. A typical HC gate powered at 5 volts consumes just 0.1 milliwatt when operating at 100 kHz. This increases to 1 milliwatt at 1 MHz and to 10 milliwatts at 10 MHz. Keep in mind, too, that these are average operating frequencies. A device that spends a lot

Table I. HCMOS Mail-Order Sources

All Electronics Corp.

P.O. Box 567
Van Nuys, CA 91408
1-800-826-5432

Digi-Key Corp.

701 Brooks Ave. S.
P.O. Box 677
Thief River Falls, MN 56701
1-800-344-4539

JDR Microdevices

110 Knowles Dr.
Los Gatos, CA 95030
1-800-538-5000

Jameco Electronics

1355 Shoreway Rd.
Belmont, CA 94002
415-592-8097

Mouser Electronics

2401 Hwy. 287 N.
Mansfield, TX 76063
1-800-34-MOUSER

Note: The above is only a partial listing of possible mail-order suppliers of HCMOS devices.

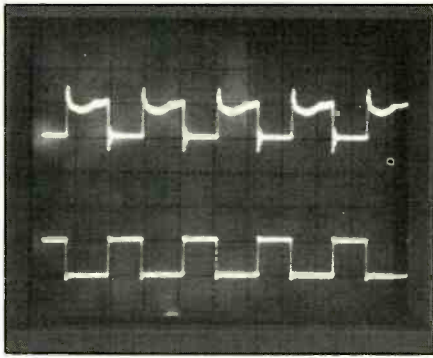

Fig. 3. Upper trace is a noisy square-wave input to a 74HC04 inverter; lower trace shows how HC's wide noise margin allows inverter to ignore noise and give a clean output.

of time "idling" will have a very low average frequency, even if it operates at high speeds some of the time.

Low power consumption means you can use smaller-capacity power supplies, with less need for heat sinks and cooling fans. Because HC devices run cooler than other ICs, they're more reliable. The bottom line, then, is that HC devices are actually a great deal less expensive to use than TTL devices, perhaps not in terms of the devices themselves but certainly in terms of the cost of the components used in their power supplies.

Inputs and Outputs

Because of their extremely high input impedance, input current requirements of HC devices are very small, averaging less than 1 microampere per gate. Output drive capability is 4 milliamperes for both source and sink currents and is as much as 6 milliamperes for bus-driver outputs, with an absolute maximum of 25 milliamperes. This is more flexible than LSTTL, which can sink but not source 4 milliamperes.

There is virtually no restriction on fanout of HC devices to other HC devices. Figure 2 shows how one HC output can "fan out" to drive as many HC inputs as you'll ever need.

Power-supply voltage range	2 to 6 volts dc
Power consumption	
quiescent power consumption per gate	25 μ W
operating power/gate at 100 Hz	0.1 mW
1 MHz	1 mW
10 MHz	10 mW
Operating speed	comparable to LSTTL
Propagation delay	8 ns
Noise immunity margin (4.5-V supply)	1.4 volts (high) 0.9 volt (low)
Output drive capability	4 mA source/sink current (same as LSTTL)
Operating temperature range	-40° to +85°C
Same functions and pinouts of TTL and 4000-series CMOS	
Easily interfaces with other logic families and operating voltages	

As with other CMOS devices, input switching levels vary with supply voltage. The maximum input guaranteed to be considered a low is $0.2V_{cc}$, and the minimum high input is $0.7V_{cc}$. So with a 5-volt supply, inputs less than 1 volt are lows, while those greater than 3.5 volts are highs. But with a 2-volt supply, a low must be 0.4 volt or less, and a high must be 1.4 volts or greater.

Outputs of HC devices can swing virtually from rail to rail, to within 0.1 volt of ground and V_{cc} . Output buffering gives sharp output signal transitions.

These input and output characteristics mean that HC devices exhibit good immunity to noise. In a 5-volt circuit, for example, the maximum low output is 0.1 volt, but any input up to 1 volt is considered a low. So you have at least 0.9 volt of noise margin between an HC "low" output and the input it connects to. Logic "high" inputs do even better, with 1.4 volts of noise margin between V_{out} (4.9 volts minimum) and V_{in} (3.5 volts minimum). Figure 3 shows how a considerable amount of input noise doesn't affect the output of an HC gate.

Operating Speed

At 4.5 volts, the propagation delay

of HC is 8 nanoseconds, which is comparable to LSTTL and three times faster than 4000-series CMOS devices operating at 15 volts. This means that HC devices can be used at speeds of up to 40 MHz. Propagation delays vary somewhat with voltage. With a 2-volt supply, for example, the delay increases to 22 nanoseconds.

Are there any reasons not to use high-speed CMOS? Its fast switching speed means that HC devices are

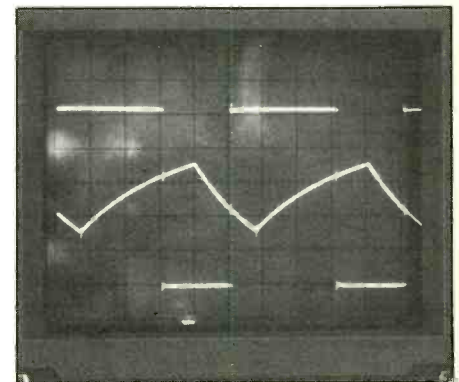

Fig. 4. A Schmitt trigger, such as the 74HC14, "squares up" slowly changing inputs to HC devices. Triangular wave in center is input to 74HC14 inverter. Square wave superimposed on it is inverter's output that has sharp rise and fall times required by HC devices.

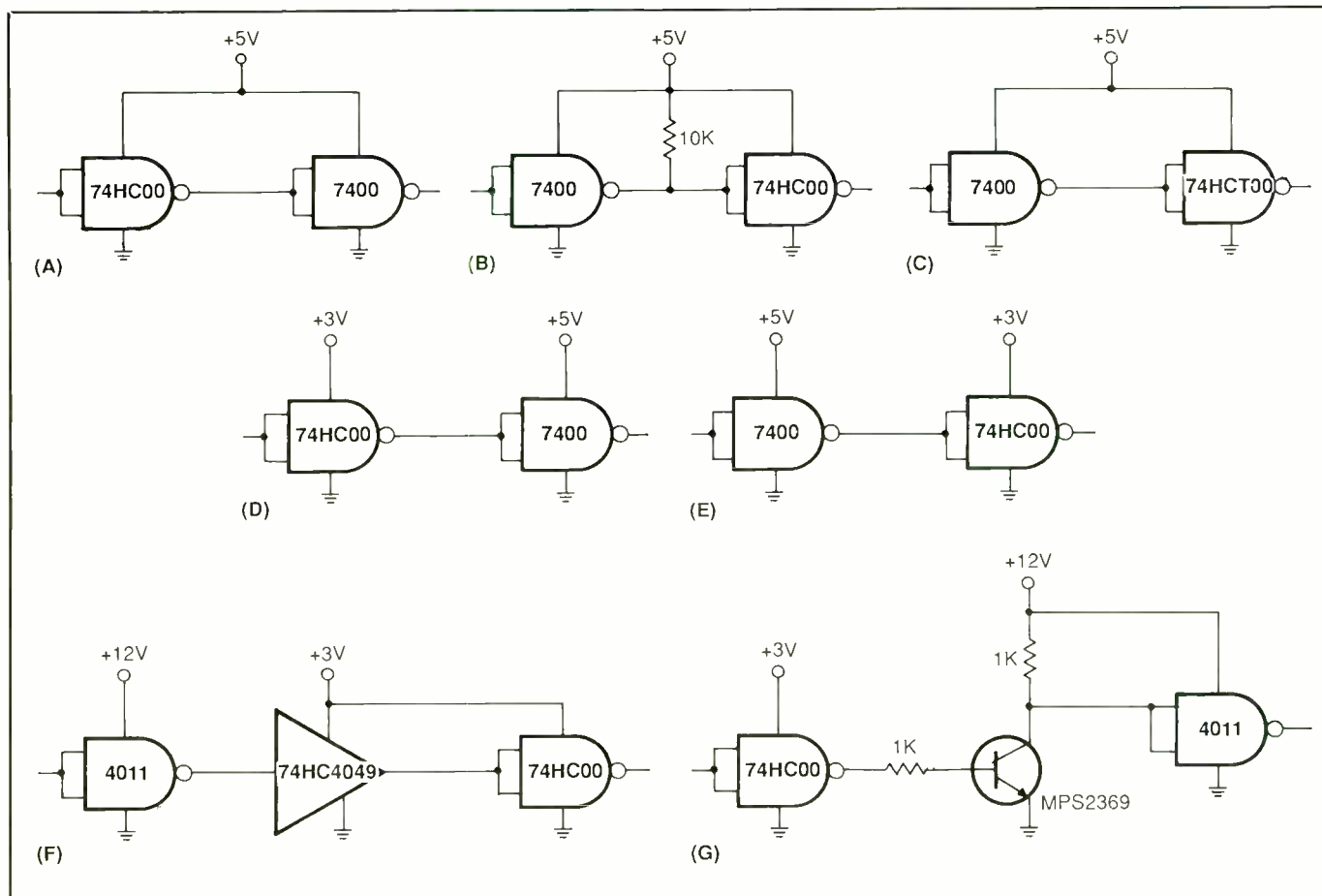

Fig. 5. High-speed CMOS is easy to interface to other logic families and operating voltages. Circuits in (A) through (E) interface HC to TTL, while (F) and (G) interface HC with 4000-series CMOS operating at higher voltage.

more likely to generate high-frequency noise spikes, compared to the slower 4000-series CMOS. Therefore, power-supply regulation and decoupling considerations are more critical for HC devices.

At the same time, for truly high-speed applications, Schottky TTL (identified by a 74S prefix) is more than twice as fast as HC logic. The next generation of CMOS, ACL (Advanced CMOS Logic), improves on HC, with propagation delays of 3 nanoseconds coupled with 24-milliampere drive capability.

Rules for Using HC

Precautions and other special considerations to remember when using HC devices are similar to the usual rules for any other MOS device. Un-

used inputs should be tied either to ground or to V_{cc} , whichever is more convenient, to keep input gates from self-biasing into their linear operating range and, thus, drawing unnecessary current and possibly affecting circuit operation.

Most HC inputs and outputs include diode-resistor networks that are designed to protect them against damage resulting from electrostatic discharge. Even so, it is good insurance to carefully handle HC devices to avoid static charges at the origin.

Like other CMOS ICs, HC devices may be vulnerable to latch-up, which can occur if an input voltage goes higher than V_{cc} or lower than ground and forces the input-protection diodes to conduct. A low-resistance path from V_{cc} to ground may then be

created, causing the IC to draw a large amount of current, possibly enough to "fry" the IC. To prevent this, input currents should be limited to 20 milliamperes or less.

This is particularly important for off-board inputs, such as from signal generators, which may be left on after the CMOS circuit is powered down. Current-limiting resistors in series with such inputs will prevent large latch-up currents from flowing.

Another consideration with HC devices, again typical of all CMOS, is that input clocks must have fast rise and fall times—0.5 microsecond or less at 4.5 volts is recommended. This will prevent output oscillations or false triggering caused by noise generated during slow input signal transitions.

For unavoidably slowly changing inputs such as RC timing ramps, a Schmitt trigger (such as the 74HC14) can be used to square up the signal. Figure 4 illustrates the effect of a Schmitt trigger on a slowly changing input. Several HC devices—including the 74HC73, 74HC74, 74HC107, 74HC109 and 74HC112 flip-flops—have Schmitt-triggers already built in at their inputs.

Although you have wide latitude in choosing a supply voltage for an HC circuit, the supply should be regulated and decoupled to minimize noise spikes caused by HC's fast switching speeds. If of sufficient amplitude, this noise can generate rfi (radio-frequency interference) or cause false triggering. As a rule of thumb, use a 10- to 50-microfarad electrolytic capacitor for power supply decoupling, along with a 0.01-microfarad capacitor for every 2 to 5 packages and a 0.1-microfarad capacitor for every 10 packages, to minimize the switching noise.

As you can see, there are some rules that must be observed when using HC devices, but for the most part they're no more restrictive than those required for other CMOS devices. Improved technology is making electrostatic discharge damage and latch-up less of a problem than they've been in the past.

Interfacing to HCMOS

The HC family is unique in that it includes some functions of 4000-series CMOS as well as those of TTL. This should limit the need to mix logic families within a circuit. But when it can't be avoided, HC devices can easily be interfaced with other logic families and operating voltages.

Figure 5 shows several examples of this. The circuits shown use NAND gates, but the interfacing techniques can be used with other devices in the families shown.

In Fig. 5(A), an HC output powered at 5 volts directly drives two

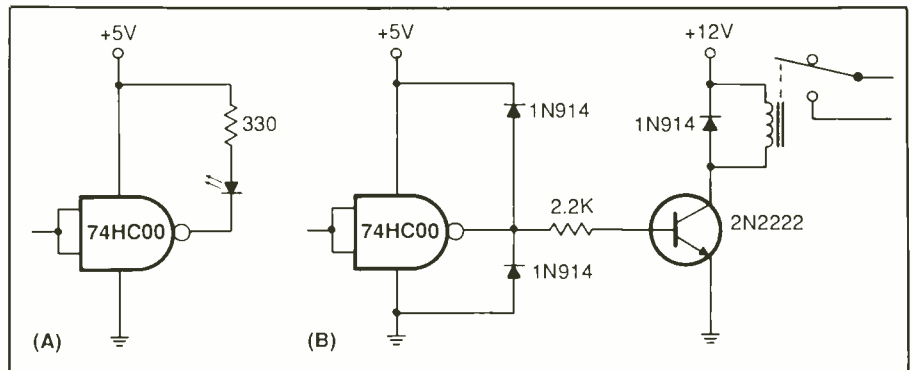

Fig. 6. An HC output can be used to directly drive a LED (A), while a transistor (B) provides increased drive current to operate a relay.

TTL inputs (or it can drive up to 10 LSTTL inputs). In the other direction, a pull-up resistor is needed at the TTL output to be sure it provides the 3.5 volts required for the HC gate's high-level input, as in Fig. 5(B). Another solution, shown in Fig. 5(C), eliminates even the need for a pull-up resistor.

A sub-family of the HC family, the HCT series, is similar to HC but with TTL-compatible input levels, in which a low is 0.8 volt or less and a high is 2 volts or greater. HCT also has stricter power-supply requirements (4.5 to 5.5 volts), reflecting its more narrow purpose.

Because of their different input-level specifications, HCT devices have less noise immunity than regular HC devices. But as TTL-to-HC interfaces, they're ideal. In most cases, HCT devices can also serve as drop-in replacements for LSTTL, with lower power consumption.

In general, the same rules for interfacing HC with TTL also apply to interfacing to NMOS devices such as microprocessors and memories. Also, HC is ideal for maintaining the low power consumption of circuits that use CMOS microprocessors.

Operating at 3 volts, HC can interface directly with 5-volt TTL, as shown in Figs. 5(D) and 5(E). If both devices use the same supply voltage, 4000-series CMOS can also interface directly with HC. At different supply

voltages, Fig. 5(F) shows how a 4049 or 4050 buffer (either the HC or metal-gate version) can be used as a "down" voltage converter.

A transistor is a convenient way to convert up to a higher voltage, as illustrated in Fig. 5(G). For best results at high frequencies, use a high-speed switching transistor.)

The absolute maximum output drive rating for HC devices is 25 milliamperes (35 milliamperes for bus-driver outputs). At currents above 4 milliamperes, the outputs will no longer swing rail to rail, but they can still be used to drive LEDs or other higher-current loads. Figure 6(A) shows an HC output powering a LED at 10 milliamperes.

A transistor can be used to boost the output drive even further. Figure 6(B) shows an HC output controlling a transistor, which in turn controls a relay. Diodes at the output of the NAND gate protect the gate from

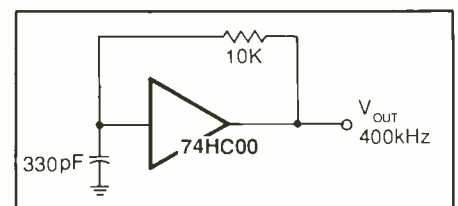

Fig. 7. A Schmitt-trigger inverter can be configured as a simple oscillator that can be used to clock other HC circuits.

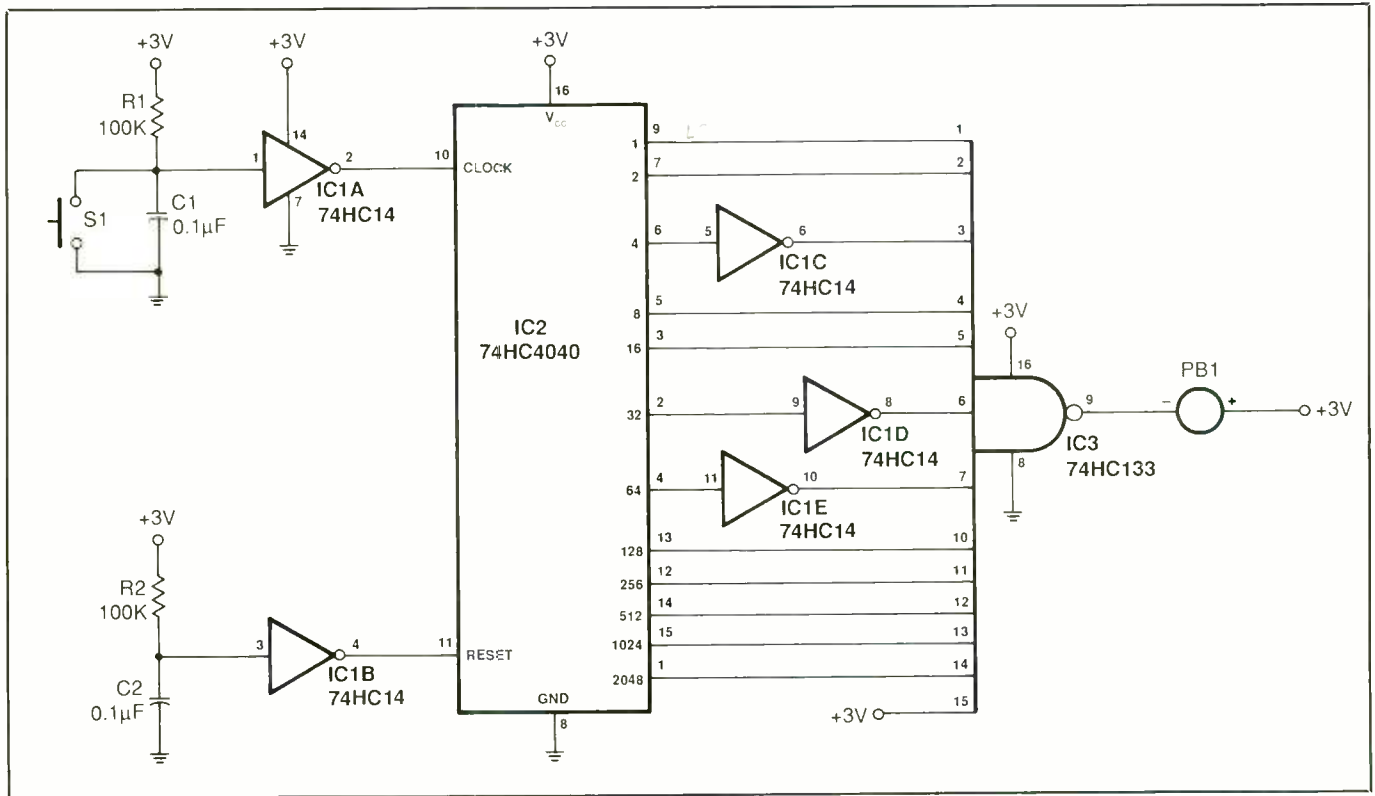

Fig. 8. This circuit uses three HC devices to sound an alarm when S1 is toggled 100 times.

current spikes caused by the relay's switching.

Figure 7 shows a simple oscillator configured from a 74HC14 Schmitt trigger. Substituting different resistor or capacitor values changes the frequency of the oscillator, which can serve as a clock oscillator for other HC circuits.

Another candidate for a clock circuit for HC devices is the TLC555, a low-power CMOS version of the popular bipolar 555 timer chip. The TLC555 can use power supplies that deliver at little as 2 volts, and operates at frequencies up to 2 MHz.

An HCMOS Counter

Figure 9 shows a counting circuit built around HC devices. This circuit counts the number of times a switch toggles. At a count of 100, it turns on a buzzer.

Integrated circuit IC2 is a 12-bit binary counter. On power up, the charging of C2 through R2 holds pin

3 of IC1 low for a few milliseconds. This causes a "high" to appear at pin 11 of IC2, which resets the counter. Resistor R1, capacitor C1 and another inverter in IC1 make up a debouncing circuit that ensures that each switch toggle produces one and only one clock pulse.

Each time switch S1 is pressed, the count of IC2 advances. Inverters are used at the appropriate counter outputs so that all inputs to IC3, a 13-input NAND gate, are high at a count of 100 (binary 1100100). When this occurs, the output of IC3 goes low and piezoelectric buzzer PB1 sounds. By changing the number and locations of the inverters at IC2's output, the circuit can be programmed to sound the alarm at any count between 1 and 4,095.

Because it uses HC devices, the Fig. 8 circuit can be powered by two AA (or AAA) cells. It uses virtually no power until the buzzer comes on. Therefore, the circuit can be left

"waiting" for counts without worry of battery run-down.

This is just one example of a circuit that is well suited for design with HC devices. High-speed CMOS is especially appropriate for circuits like this, which require low power consumption or low-voltage operation. But just about any type of logic circuit can be built, and often built better, with this new and useful family of integrated circuits.

In parting, a couple of final notes are in order. Unlike the case with 4000-series CMOS, you can't conveniently power an HC circuit directly from a 9-volt battery, though there are plenty of other power-supply options. Also, if you're already stocked up with TTL or other CMOS ICs, you may be reluctant to invest in a new technology. However, if you need low power, low operating voltage, and/or (moderately) high switching speeds, high-speed CMOS is ideal technology to use.

ME

An Electronic Greeting Card

Flashing LEDs and colorful electronic "ornaments" give this different kind of holiday greeting card a high-tech look

By Lee Hart

Here's a Christmas "card" that your friends, relatives and business associates won't soon forget. Send them an electronic Christmas tree, decorated with blinking lights and colorful ornaments. Just connect a 9-volt battery (which doubles as a stand to keep it upright), and it will provide weeks of Christmas cheer. Its cost is modest, too.

Not just another 555-timer-based blinker, our "card" uses CMOS technology and a switched-capacitor converter that minimizes power consumption so that recipients can enjoy their card/ornament the entire season long. Drawing just 1 milliampere of current to power its blinking lights, the card can be run for about two weeks on a fresh alkaline battery. (Be sure to include the battery when you send this card off.) The circuit is protected from battery reversal and damage from static electricity, as well!

You can make as many of these "cards" as you wish at a cost of \$10 or less per card. You can package it carefully for mailing. The card also lends itself to personal hand delivery, packaged in an attractive gift box. Make your delivery rounds about a week before Christmas so that recipients will have it operating right on up to the New Year.

About the Circuit

Shown in Fig. 1 is the complete schematic diagram of the project. The heart of this circuit is *IC1*, a CMOS

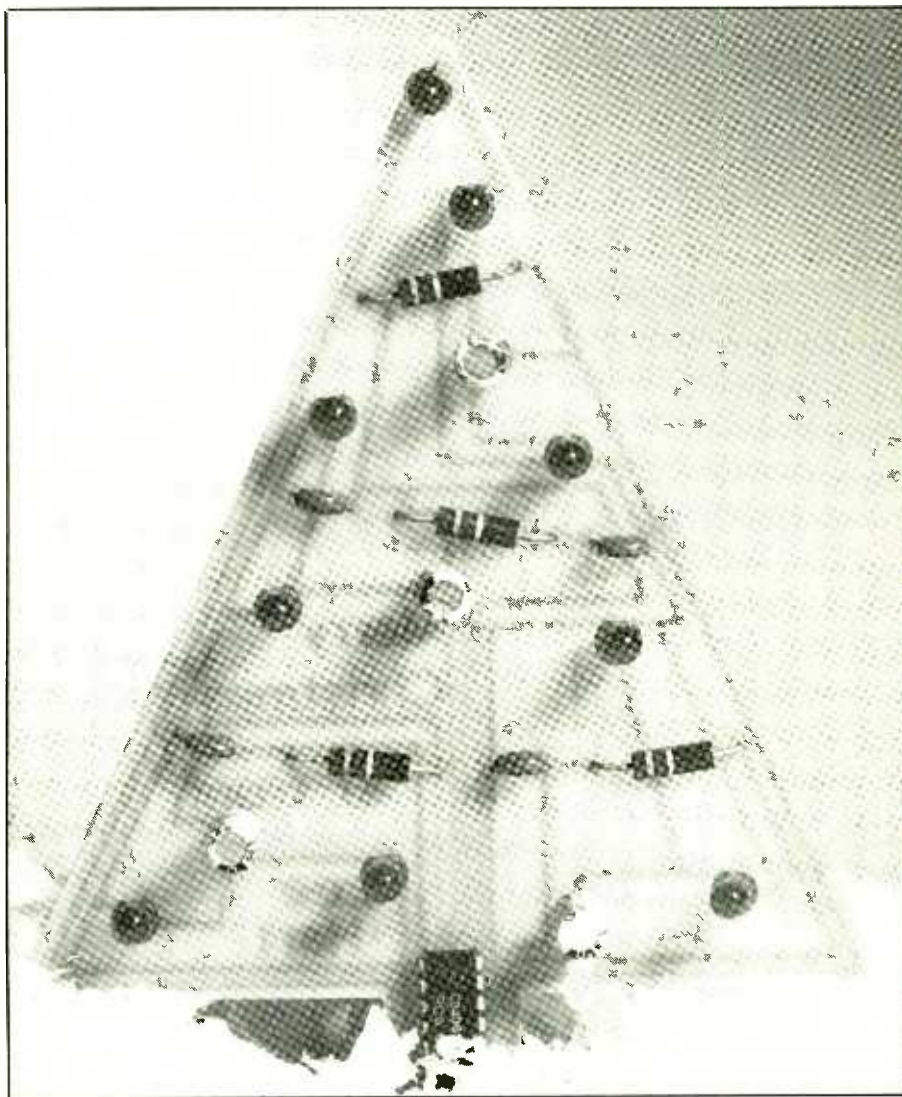

CD4093 quad NAND gate with Schmitt-trigger inputs. The Schmitt-trigger gate was selected for its "split personality." When the gate's output is at logic low, its input switching threshold is about one-third of the supply voltage (called V_{DD} for

CMOS components). When the output is high, the input threshold is approximately two-thirds V_{DD} . This peculiar trait makes it easy to configure an oscillator simply by connecting a resistor between the gate's input and output terminals and a capa-

EXPAND YOUR CAREER HORIZONS...

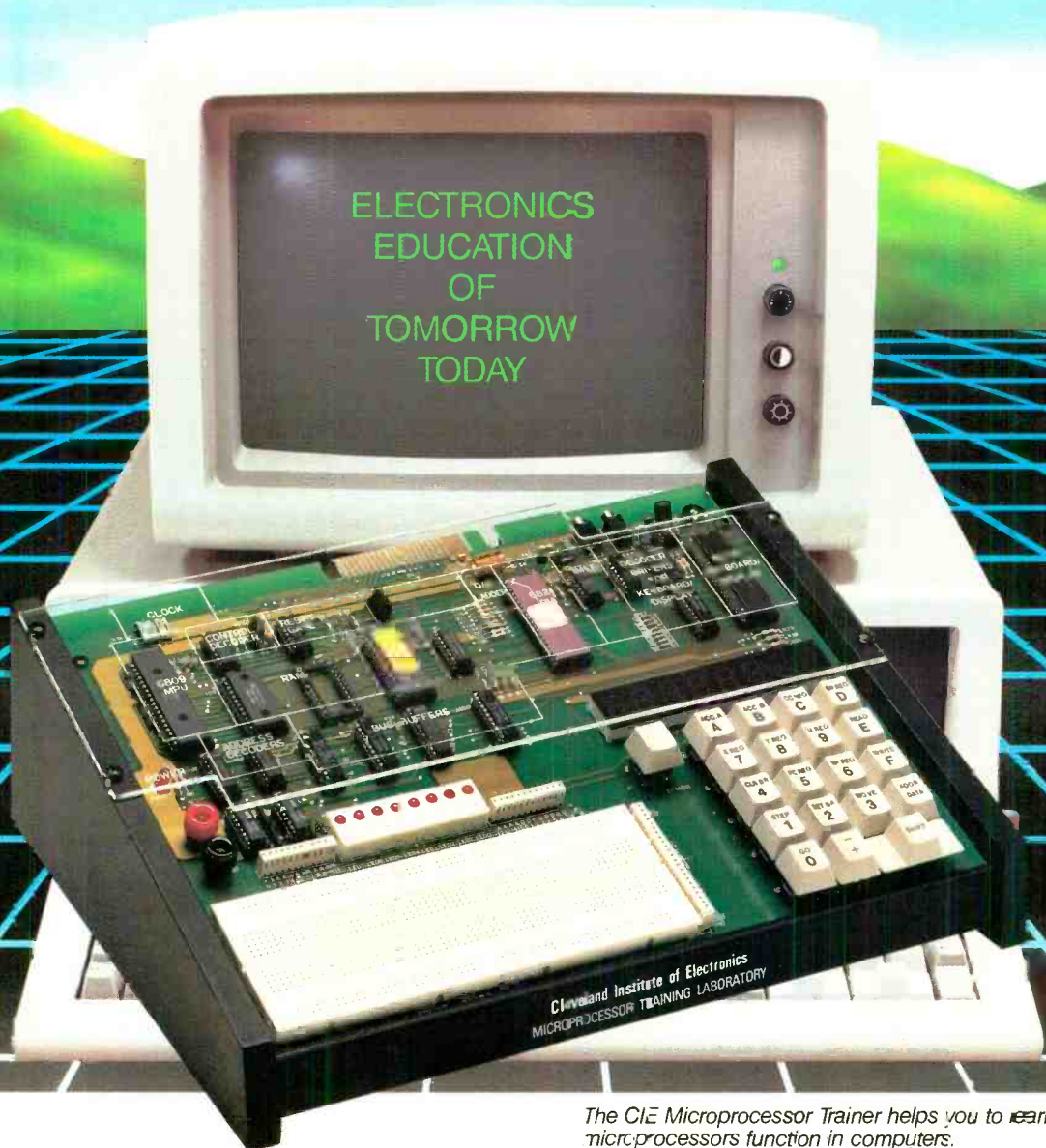

The CIE Microprocessor Trainer helps you to learn how circuits with microprocessors function in computers.

START WITH CIE.

Microprocessor Technology. Satellite Communications. Robotics. Wherever you want to go in electronics... start first with CIE.

Why CIE? Because we're the leader in teaching electronics through independent study. Consider this. We teach over 25,000 students from all over the United States and in over 70 foreign countries. And we've been doing it for over 50 years, helping thousands of men and women get started in electronics careers.

We offer flexible training to meet your needs. You can start at the beginner level or, if you already know something about electronics, you may want to start at a higher level. But wherever you start, you can go as far as you like. You can even earn your Associate in Applied Science Degree in Electronics.

Let us get you started today. Just call toll-free **1-800-321-2155** (in Ohio, 1-800-362-2105) or mail in

CIRCLE 98 ON FREE INFORMATION CARD

the handy reply coupon or card below to:
Cleveland Institute of Electronics,
1776 East 17th Street, Cleveland, Ohio 44114.

CIE World Headquarters

AMO-121

Cleveland Institute of Electronics, Inc.
1776 East 17th Street • Cleveland, Ohio 44114

Please send your independent study catalog.
For your convenience, CIE will try to have a representative contact you — there is no obligation.

Print Name _____

Address _____ Apt. _____

City _____ State _____ Zip _____

Age _____ Area Code/Phone No. _____

Check box for G.I. Bill bulletin on Educational Benefits

Veteran Active Duty **MAIL TODAY!**

Just call toll-free **1-800-321-2155** (in Ohio, 1-800-362-2105)

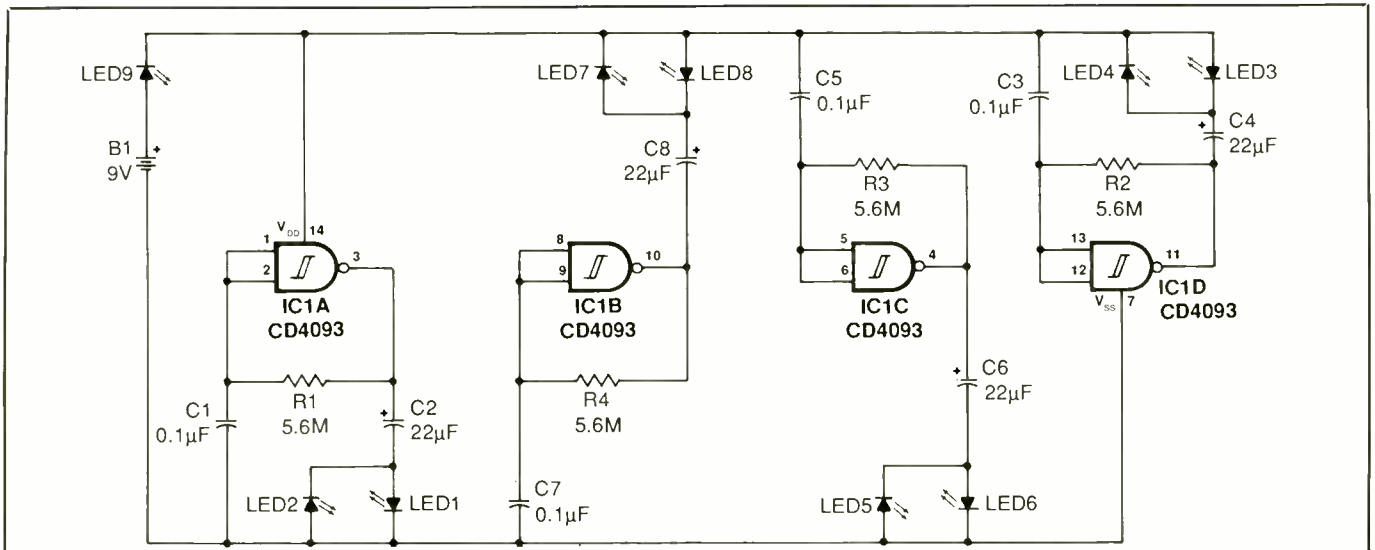

PARTS LIST

Semiconductors

IC1—CD4093 quad 2-input Schmitt-trigger NAND gate

LED1 thru LED9—Jumbo light-emitting diode (any color)

Capacitors

C1, C3, C5, C7—0.1- μ F, -20%/+80% disc ceramic

C2, C4, C6, C8—22- μ F, 10-volt electrolytic

Resistors (1/2-watt, 20% tolerance)

R1 thru R4—5.6 megohms

Miscellaneous

B1—9-volt battery

Printed-circuit boards (as many as needed; see text); snap connectors for B1; No. 2 machine hardware (optional; see text); dry-transfer lettering kit (optional; see text); clear spray acrylic; solder; etc.

Note: The following items are available from Lee Hart, 28612 Middle Crossing Rd., Dowagiac, MI 49047 (616-782-3980): etched but not drilled or cut to shape pc board, \$3 each; complete kit of parts including etched, cut and drilled pc board and all components, \$10. Add \$1.50 P&H. Michigan residents, please add state sales tax.

Fig. 1. Complete schematic diagram of electronic Christmas "card."

citor from the input terminal to circuit ground.

To understand how this circuit works, let's examine the stage built around IC1A. Since both inputs of this gate are tied together, this gate operates as a simple inverter. When the output is high, resistor *R1* charges capacitor *C1* on the input to the gate. After a short time, the input voltage reaches the $0.67V_{DD}$ threshold. At this point, the gate's output suddenly switches low. Resistor *R1* discharges *C1* until the input voltage reaches $0.33V_{DD}$. Now the output switches high, and the cycle repeats. As you can see, this is the action of a simple oscillator operating at a frequency of approximately $1/(1.4RC)$. A sawtooth waveform cycling between $0.33V_{DD}$ and $0.67V_{DD}$ appears at the input of the gate, while

the output is a square waveform.

Power consumption of this arrangement is very low. The CMOS gate uses almost no current. The resistor, the only power-dissipating element in the circuit, has a value that is so large that the oscillator runs on just a few microamperes of current.

You could connect a light-emitting diode to the output of the IC1A gate through a suitable value of series resistance. However, this would negate the low-power nature of the circuit. A LED requires just 1 volt to light but at least 10 milliamperes of current to generate a reasonable brightness level. With a 9-volt battery, 8 volts gets used up as heat dissipated by the series resistor. So, since battery-powered heaters in circuits have never been popular, there is a far better way to go.

Suppose you use a capacitor in series with the LED at the output of the gate. It's a well-known fact that capacitors don't dissipate power; rather, they store power that they yield later on demand to the circuit load. The rub is that if you try a capacitor/LED series arrangement, the LED will blink just once, lighting as it discharges the capacitor. After this, the LED acts like a blocking diode that prevents the capacitor from discharging.

Connecting a second LED in reverse polarity across the first (as illustrated by LED1, LED2 and C2) offers an elegantly simple solution. Now, when the gate's output goes high, C2 charges and the charging current lights LED1. Once C2 is fully charged, the current goes to zero and the LEDs extinguish. When the out-

put of the gate goes low, *CI* discharges its stored energy through *LED2*, generating a brief flash.

In engineering jargon, the double LED/capacitor arrangement is called a switched-capacitor current-mode downconverter. It converts a high-voltage, low-current source (the battery) into a low-voltage, high-current pulsed output, which causes the LEDs to briefly flash. Thus, the nine LEDs used in this circuit can be made to blink at high brightness while reducing battery current by a ratio of about 10:1.

As you can see in Fig. 1, there is no resistor to limit the capacitor's charge/discharge current. Theoretically, the current would be infinite and so turn the LEDs into DEDs (dark-emitting diodes). In practice, however, the CMOS gate has an output resistance of a few hundred ohms. This limits peak current to about 50 milliamperes, which works out very well. LEDs are more efficient light producers at high currents, and the human eye tends to overestimate the brightness of flashing objects.

You will note in Fig. 1 that the three remaining oscillators in the circuit are similar but not identical to the *IC1A* oscillator arrangement. If all were the same, all four oscillators would tend to run at exactly the same frequency. Since they share an unregulated power supply, battery *B1*, they would blink in lock-step, with groups of four LEDs flashing in unison. This would make a very monotonous and uninteresting project.

A slight rearrangement of the components yields equivalent but not identical oscillators. This exaggerates the differences between the gates and component values to keep the oscillators from synchronizing with each other.

Two purposes are served by *LED9*, which is directly in series with the battery. The LED serves as a blocking diode to protect *IC1* should battery power be connected in re-

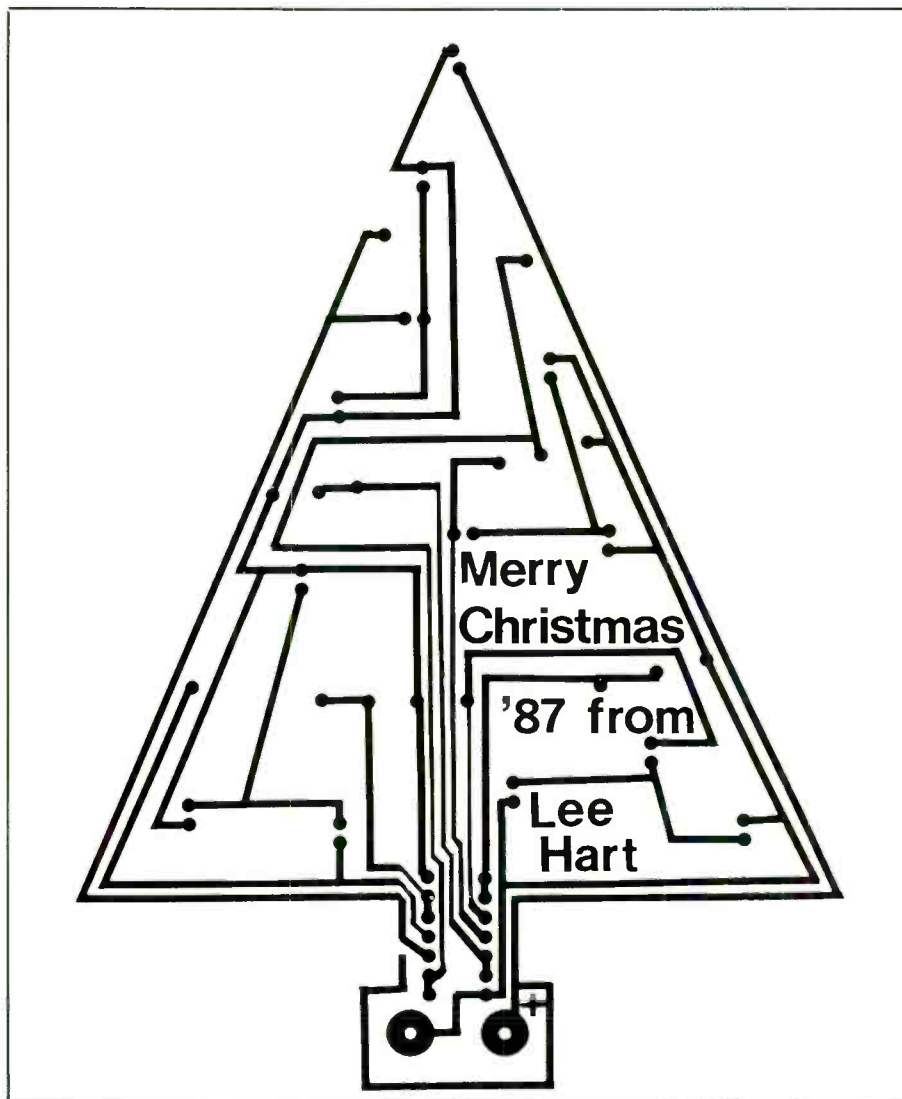

Fig. 2. Actual-size etching-and-drilling guide for Christmas-tree card's printed-circuit board. Other shapes are possible, as discussed in text.

verse polarity of what it should be. Secondly, *LED9* lights with each pulse of battery current as any capacitor in any oscillator gate circuit charges. Thus, *LED9* does not exactly blink; it "twinkles" like a star, which is the reason why this LED is located at the top of the tree-shaped printed-circuit board used for the project.

Construction

Because of its intended use, the only construction approach for this proj-

ect should be a printed-circuit board, preferably using G-10 Fiberglass pc blank. This material is green (for the Christmas season, of course.) However, if you cannot obtain G-10 blank, you can use any other, but paint its component side green just before component installation.

Fabricate as many of your own boards as needed using the actual-size etching-and-drilling guide shown in Fig. 2. If you wish, you can work into the blank areas a Christmas message that will personalize the "card." For example, you might

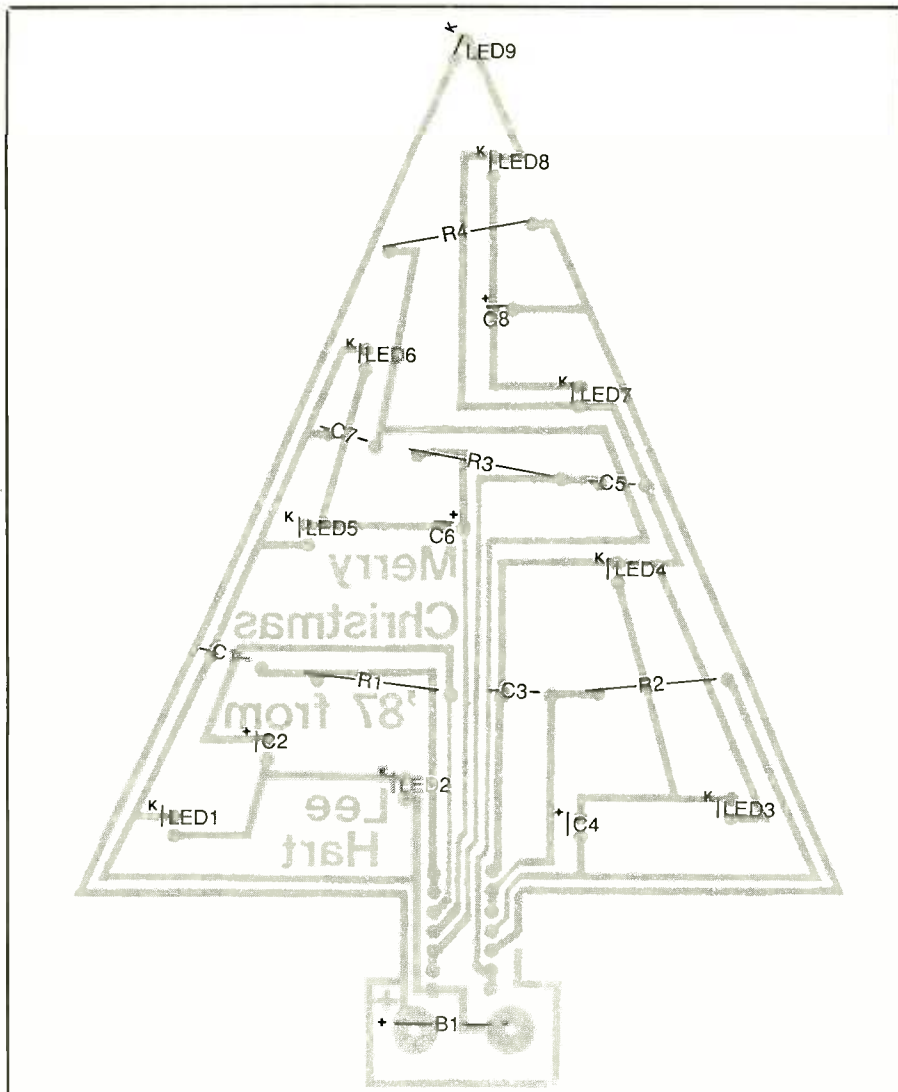

Fig. 3. Wiring guide for pc board.

place the legend "Christmas 1988" in one free area and your name in another free area, using dry-transfer lettering in the appropriate pc guide areas. When the boards are etched, your message will appear in bright copper. When making the boards, begin with rectangular single-sided pc blanks that are approximately the same height as the pc guide and at least as wide as the widest point of the tree shape.

After preparing the boards, etch and drill them. Then carefully trim the boards to shape. The odd Christmas-tree (arrow-head?) shape of the

boards can be a bit of a problem to manage. If you're making just one board, you can rough out the shape with tin snips, trim it to final shape with a nibbling tool and smooth its edges with a fine file or emery cloth.

If you're making a number of boards to use as the wiring medium for your "cards," a faster approach would be to sandwich together five to ten boards in a vise or C clamp and use a saw to cut them all to shape and emery cloth to finish the edges. When making the sandwich, make sure to align all boards before clamping them together. An easy way to do

this is to pass a thin wire brad through two or three holes (say, at the three points of the triangular shape of the main tree) in one board and then lowering onto the ends of the brads the remaining boards that will make up the sandwich in the same orientation. This way, all boards in the sandwich can be cut to shape simultaneously without danger of slicing through traces.

Once the boards have been cut to shape, refer to the wiring guide shown in Fig. 3 for component installation. You'll note in this illustration that not all components are arranged in the traditional horizontal and vertical orientations. The reason for this is that the LEDs serve as the Christmas-tree lights, the colorful capacitors and resistors as the "ornaments" and the black integrated circuit as the tree "trunk."

Note in the Parts List that the resistors are specified at a tolerance of 20 percent and that a $-20\%/+80\%$ tolerance is given for the capacitors. This is a radical departure from the norm in modern solid-state circuits, but it's one of those rare cases in which wide-tolerance components works to your benefit. While having no effect on the basic operation of the oscillator circuits, low-quality, off-tolerance resistors and capacitors virtually assure that the LEDs won't blink in lock-step, as would be the case if precision components were used.

If you painted the component side of the boards, use the point of a needle or straight pin to clear all holes of paint. Then, referring to the wiring guide shown in Fig. 3, install and solder into place the resistors in the specified locations. Then do the same with the capacitors, making sure that you properly polarize the leads of the electrolytics before soldering them to the copper pads on the bottom of the board.

Next, install the LEDs in their re-

(Continued on page 96)

SELECT 5 BOOKS for only \$3.95

(values to \$132.70)
and get a Free Gift!

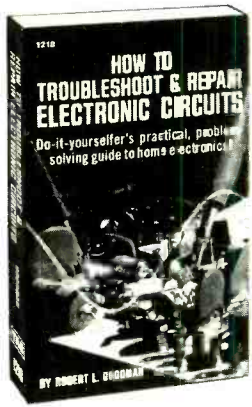

1218P \$16.95



1897P \$13.95

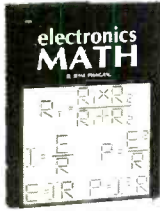

1962 \$22.95

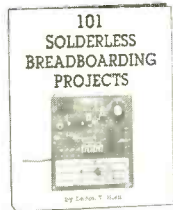

2895 \$24.95



1199P \$18.95

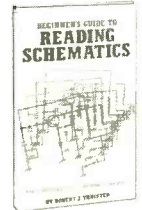

1536P \$8.95



2922P \$15.95



2965 \$24.95



1939P \$19.95



1964P \$12.95

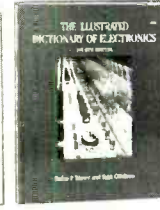

2900 \$36.95
Counts as 2



2853 \$23.95

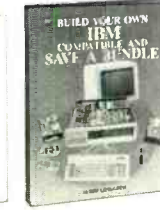

2831 \$22.95

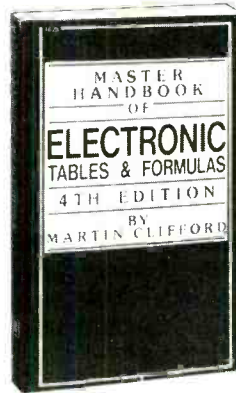

1625P \$16.95



2626P \$14.95



2885 \$16.95



2786 \$28.95
Counts as 2



2660P \$19.95

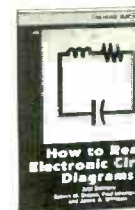

2880 \$20.95



1793P \$9.95

Electronics projects . . . ideas . . . the latest technology
all at up to 50% off publishers' prices!

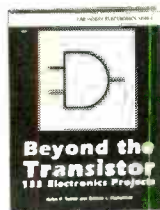

2887 \$16.95

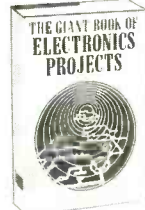

1367P \$17.95

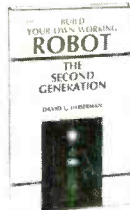

2781 \$18.95



2701P \$17.95



2635 \$19.95



2790 \$18.95



2735P \$13.95



2795 \$29.95
Counts as 2

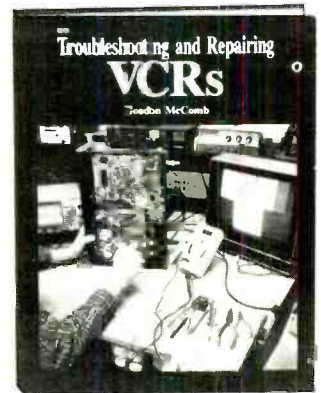

2960 \$26.95

FREE when you join!

15 Easy Electronic
Projects From Delton T. Horn

(a \$7.95
value!)

Projects you can build—some
unique, some old favorites—from
the author's vast treasury of elec-
tronics know-how.

Membership Benefits • Big Savings. In addition to this introductory offer, you keep saving substantially with members' prices of up to 50% off the publishers' prices. • **Bonus Books.** Starting immediately, you will be eligible for our Bonus Book Plan, with savings of up to 80% off publishers' prices. • **Club News Bulletins.** 14 times per year you will receive the Book Club News, describing all the current selections—mains, alternates, extras—plus bonus offers and special sales, with hundreds of titles to choose from. • **Automatic Order.** If you want the Main Selection, do nothing and it will be sent to you automatically. If you prefer another selection, or no book at all, simply indicate your choice on the reply form provided. As a member, you agree to purchase at least 3 books within the next 12 months and may resign at any time thereafter. • **Ironclad No-Risk Guarantee.** If not satisfied with your books, return them within 10 days without obligation! • **Exceptional Quality.** All books are quality publishers' editions especially selected by our Editorial Board. MDNE-1188

All books are hardcover unless numbers are followed by a "P" for paperback (Publishers' Prices Shown)
© 1988 ELECTRONICS BOOK CLUB®, Blue Ridge Summit, PA 17294-0810

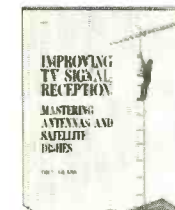

2970 \$23.95

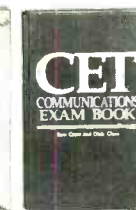

2910 \$24.95

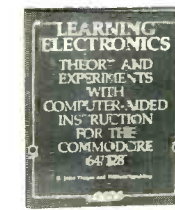

2882 \$24.95



1370P \$18.95



2617 \$17.95



2992 \$24.95

Photo Sensor Operating-Status Indicator

From data-transfer to power, this device centralizes visible and audible operating-status indication of separate components in a system without making electrical connections

By Adolph A. Mangieri

Modern electronic and computer components usually have one or more light-emitting-diode or lamp indicators to let a user know about their operating status. For a typical personal-computing system, this might mean half-a-dozen or more LEDs spread among computer, printer, modem, etc. Moreover, a printer buffer alone might have this many indicators.

Since some of these system components are not located in a user's easy line of sight, it's inconvenient to keep track of their operation. This project enables you to do so with a multi-channel LED display that, unlike a "power director" accessory, also indicates the condition of a data indicator LED, such as on a printer buffer ("Full," "Pause," etc.), not just ac power for a whole unit. In addition, it doesn't require making any electrical connections to each component since our device uses photo sensors for LEDs being monitored. Furthermore, it has individual channel sound indicators in the event you walk away from the operating station to do some work nearby, and a volume control to turn audio up for distant listening.

The Audible/Visible Remote Status Indicator described here consolidates a bank of LEDs that can be located directly in your field of vision if placed under the video monitor. A

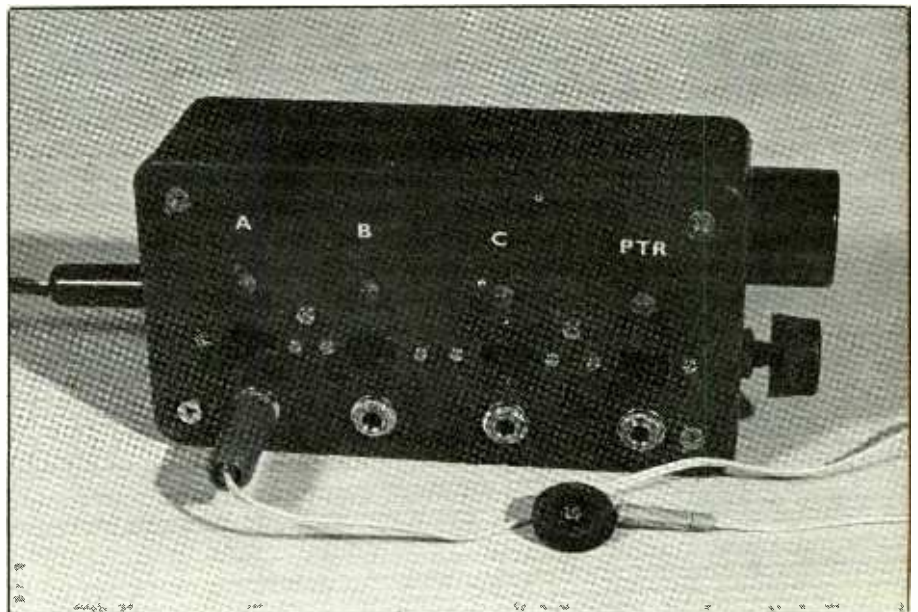

switch in each channel allows you to choose between audible/visible alert or visible-only alert. Each channel is driven by a photodetector that mounts over a LED status indicator on a specific peripheral.

This low-cost project works with any LED and incandescent-lamp status indicator. Since it requires no direct electrical connection to the equipment, it doesn't void existing warranties. It can be equipped to handle any number of channels.

About the Circuit

Shown in Fig. 1 is the schematic diagram of the circuit for Channel A of

the project, along with the common audio stage. Highly sensitive Darlington phototransistor $Q1$ positions over a remote light-emitting diode or incandescent-lamp status indicator. When $Q1$ is illuminated by the light from the LED or lamp, it conducts and drives the base of high-gain transistor $Q2$. Load resistor $R1$ limits collector current to a safe level when $Q1$ is illuminated by intense light.

Capacitor $C1$ bypasses stray ac noise pickup on the cable that connects $Q1$ to the Status Indicator. Resistor $R3$ siphons off the dark current of $Q1$ to prevent partial turn-on of $Q2$ when $Q1$ isn't being illuminated. Light-emitting diode $LED1$ turns

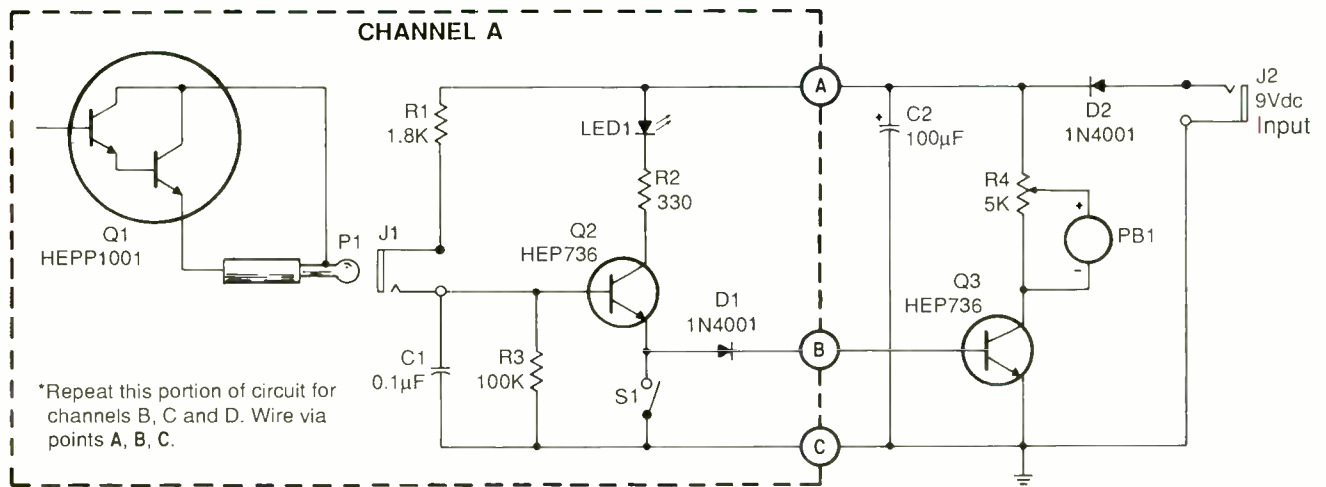

PARTS LIST

Semiconductors

D1, D2—1N4001 silicon rectifier diode
 LED1—Light-emitting diode
 Q1—ECG 3035 or HEP P1001 Darling-
 ton phototransistor
 Q2, Q3—ECG 123AP, HEP 736 or sim-
 ilar high-gain npn silicon transistor

Capacitors

C1—0.1- μ F, 25-volt disc
 C2—100- μ F, 25-volt electrolytic

Resistors (1/4-watt, 10% tolerance)

R1—1,800 ohms

R2—330 ohms

R3—100,000 ohms

R4—5,000-ohm panel-mount minia-
 ture volume control

Miscellaneous

J1, J2—1/4-inch miniature phone jack

P1—1/4-inch miniature phone jack

PB1—Piezoelectric buzzer (Radio
 Shack Cat. No. 273-065 or equivalent)

S1—Spst miniature slide or toggle switch
 Printed-circuit board or perforated
 board and suitable Wire Wrap or sol-

dering hardware; small enclosure (see
 text); twisted-pair earphone extension
 cord (Radio Shack Cat. No. 33-176 or
 similar); materials for fabricating de-
 tector housing (see text); lettering kit;
 clear spray acrylic; machine hardware;
 hookup wire; solder; etc.

Note: This list includes components for assem-
 bling a single-channel Remote Status Indica-
 tor. For additional channels, duplicate all
 components except C2, D2, J2, PB1, Q3
 and R4.

Fig. 1. Schematic diagram of project showing one LED "channel" and the common audible-alert circuit. Additional channels are identical to that shown in the boxed area and connect into the circuit via points A, B and C in identical manner.

on when Q2 is switched on by Q1's emitter current. Resistor R2 safely limits current through LED1.

When AUDIO switch S1 is set to open (off), Q2's emitter current passes through Channel A isolating diode D1 to the base of audio driver transistor Q3, which switches on and causes the supply voltage to appear across VOLUME control R4. Piezoelectric buzzer PB1 now sounds at an output level determined by the setting of R4. With S1 closed, Q2's emitter current is diverted to ground, preventing PB1 from sounding and providing only visible LED alert.

Circuitry of any additional channels added to the basic Fig. 1 circuit

is connected via points A, B and C in exactly the same manner as shown. Isolating diodes (D1) connect directly to the base of Q3 via point B. These diodes are wired in an OR logical arrangement such that PB1 sounds if any one or more status LEDs light while the channel's AUDIO switch is open.

Power for the circuit is supplied by a commonly available 9-volt dc, 150-milliamperere plug-in wall transformer, whose output plugs into the project via J2. Diode D2 protects the circuit from damage that might otherwise result if the power supply were to be connected into the circuit in reverse polarity.

Construction

Since this is basically a steady-state dc circuit, there's nothing critical about component layout and wire routing. Therefore, any traditional means of assembly can be employed to wire the circuit. You can design and fabricate a printed-circuit board or use perforated board and suitable Wire Wrap or soldering hardware to wire the circuit. The prototype was built using perforated board and was mounted inside an all-plastic project box, but you can use a box that has an aluminum front panel. The four-channel version of the circuit easily fits into a standard 4 1/2 x 2 1/2 x 1 1/2-

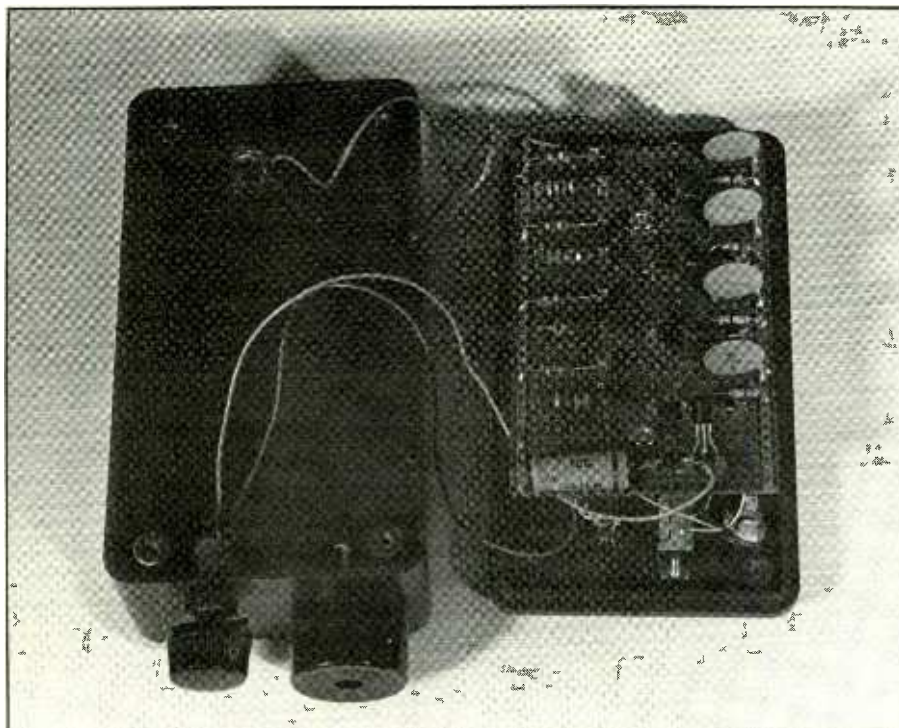

Fig. 2. Interior view of author's prototype. Circuit was assembled on perforated board using solder clips and was housed inside standard plastic enclosure.

inch project box, as shown in Fig. 2. If you add more channels, use a larger project box.

Take care to properly base or polarize the diodes, transistors, LEDs and electrolytic capacitor before soldering them into place. Except the Darlington phototransistors, LEDs, jacks, buzzer, switches and VOLUME control, all components mount on the circuit board. After wiring the board, set it aside.

Now machine the enclosure. Drill two holes for mounting the circuit-board assembly to the front panel. Lay out the front panel to determine where to drill the mounting holes for the LEDs, input jacks and switches. If you wish, you can use miniature toggle switches instead of the slide types shown in the photo of the prototype to eliminate having to cut rectangular slots and drilling two mounting holes for each switch.

If you use the box mentioned and limit your project to only four chan-

nels, drill holes for mounting the miniature VOLUME control potentiometer, buzzer and POWER jack *J3* on the side of the enclosure.

After cleaning the enclosure, label the front panel. If you use a dry-transfer lettering kit, protect the legends with two or more light coats of clear acrylic spray. Allow each coat to dry before spraying on the next.

Secure the LEDs in their holes in the front panel with panel clips or fast-setting clear epoxy cement. Identify and label the anode leads of the LEDs. Then mount the switches, jacks, VOLUME control and buzzer.

Solder color-coded hookup wires to the lugs of the panel-mounted components. Place a 1-inch-long, small-diameter plastic tube on the anode leads of all LEDs. Tie these leads together and attach to the bundle a 3-inch hookup wire. Solder the connection and push the tubing up against the bases of the LEDs.

Prepare as many 4-inch-long

hookup wires as you have LEDs by stripping $\frac{1}{4}$ inch of insulation from both ends. Trim the cathode leads of all LEDs to $\frac{1}{2}$ inch long and form a small hook in each. Crimp one wire to each cathode lead and solder. Slide 1-inch lengths of small-diameter plastic tubing onto the free ends of the wires and push them over the connections until they're flush against the bases of the LEDs.

Place the circuit-board assembly near the enclosure. Referring to Fig. 1, wire the free ends of the wires coming from the panel-mounted components into their respective points in the circuit. Mount the circuit-board assembly to the front panel with $\frac{1}{2}$ -inch spacers, $1\frac{1}{4}$ -inch machine screws, nuts and lockwashers. Leave enough slack in all wires to allow the board to be dismantled for easy troubleshooting should that become necessary.

Checkout & Use

The power supply you use with this project can be a plug-in wall-type capable of delivering a minimum of 30 milliamperes dc current per channel. You can use an unfiltered dc transformer or a 9- to 12-volt unit with filtered output.

First determine whether or not the supply has a built-in filter capacitor. Identify the polarity of the output connector using a dc voltmeter or a multimeter set to the dc-voltage function. Connect a 1,000-ohm resistor across the output connector and measure the voltage across it. Then connect a 100-microfarad electrolytic capacitor across the resistor, properly polarized, and again measure the voltage. If the voltage increases by about 40 percent with the capacitor in place, the supply doesn't have a built-in filter capacitor; you must supply it inside the project.

If you use a 6-volt unfiltered dc supply, increase the value of *C2* to 330 microfarads and verify with your meter that the potential across the

capacitor is between 8 and 10 volts. If you use a 12-volt filtered supply, change the value of $R2$ to 470 ohms.

With power applied, verify that *LED1* (for all channels) is off and that no tone sounds with *SI* set to both positions. Connect a jumper wire across the lugs of a miniature phone plug and plug it into the CHANNEL A INPUT jack. The LED for that channel should light in both positions of *SI*. Also, the tone should be heard from the buzzer only when *SI* is open (audio on). Repeat this test for all remaining channels.

If the LED in a particular channel doesn't come up to full brightness, $Q2$'s dc gain is too low. Replace $Q2$ with any high-gain (200 or greater beta) general-purpose npn silicon transistor and $Q3$ with any medium-gain (100 or greater beta) or high-gain npn silicon transistor. Later, when you're using a phototransistor pickup, if any channel's LED lights dimly when the pickup is in total darkness, the dark current of $Q1$ is too high and the value of $R3$ must be reduced until the LED extinguishes.

You can use any high-sensitivity npn-type Darlington phototransistor for $Q1$. Pretest each phototransistor by making temporary connections from it to a suitable length of two-conductor cable wired at its remote end to a miniature phone jack. Plug this into any CHANNEL input jack.

Position the sensitive surface of the transistor over any lighted LED and turn off room lights. That channel's LED should now light and a tone should be heard from the buzzer when *SI* is open. Slowly move the phototransistor away from the lighted LED source and observe how the channel LED in the project gradually dims. Moving the transistor well off to the side should cause the channel LED to extinguish. During these tests, make sure you do not touch the phototransistor's bare wire leads.

A high-sensitivity phototransistor works well with red and yellow LEDs and some of the brighter green

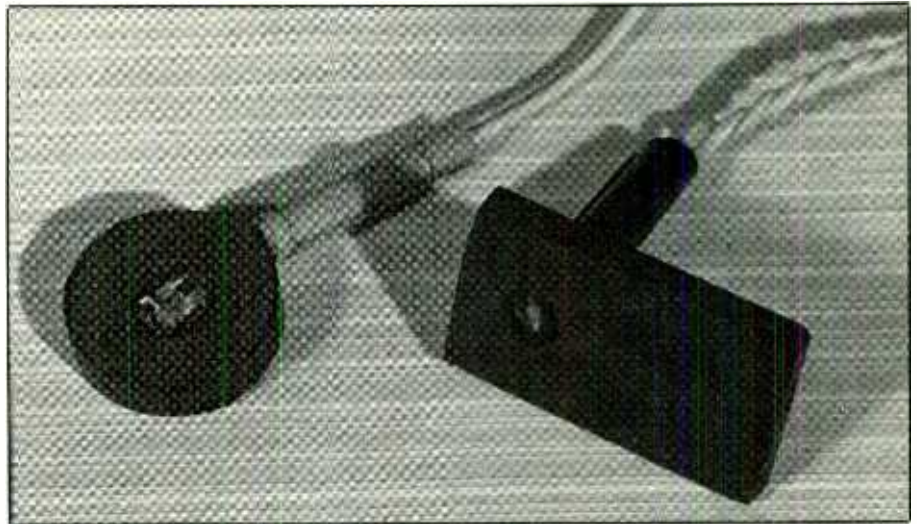

Fig. 3. Mounted side-viewing (left) and top-viewing (right) photo-Darlington transistor sensors.

LEDs. For equally bright red, yellow and green LEDs, the red variety has the best ability to irradiate the phototransistor, green the least. This is due to the much higher infrared output of the red LED and closer match with the spectral response of the phototransistor.

Perform a test on a neon lamp and note the difference in the audio tone heard from the buzzer. In this case, the light radiating from the neon lamp is modulated at the line frequency rate that, in turn, modulates the audio tone. You may also find a LED used as an indicator on a particular piece of gear energized by half-wave rectified ac that produces similar audio modulation.

Shown in Fig. 3 are mountings for side- and top-view photodetectors. Install side-viewing plastic transistors, such as the ECG 3035 and HEP P1001, in standard $\frac{1}{16}$ -inch-thick \times $\frac{1}{8}$ -inch-diameter fiber washers with $\frac{1}{4}$ -inch holes in them. Strip about $\frac{1}{8}$ inch of insulation from the ends of as many 3- to 5-foot lengths of twisted-pair earphone cables as you have designed inputs to the project for. Twist together the fine wires at both ends and tin with solder.

Carefully identify and clip off the

base leads of the phototransistors. Separate the two remaining leads of the transistor a bit, but leave them full length. Clip a heat sink onto one lead close to the transistor's case, and lap-solder a conductor at one end of the cable to the outer side of this lead. Do the same for the other lead and cable conductor. Repeat for all cables and phototransistors.

After soldering the cables to both leads of the transistors, use short lengths of electrical tape between them to insulate them from each other. Use an ohmmeter to identify the conductors at the other end of the cables that go to the emitters and collectors of the transistors. Label each accordingly. Then terminate the free ends of the cables in mini phone plugs.

Place the viewing side of the phototransistor so that it faces downward in the washer's central hole. Cement a $\frac{1}{8}$ -inch-diameter covering disk atop the washer. Make sure this disk is fully opaque to light. Use a putty-like cement, such as black epoxy putty or automobile body filler, so that it fills the gap between washer and disk when the transistor's leads are sandwiched between them. Use only enough cement to fill the gap, and take care to avoid forc-

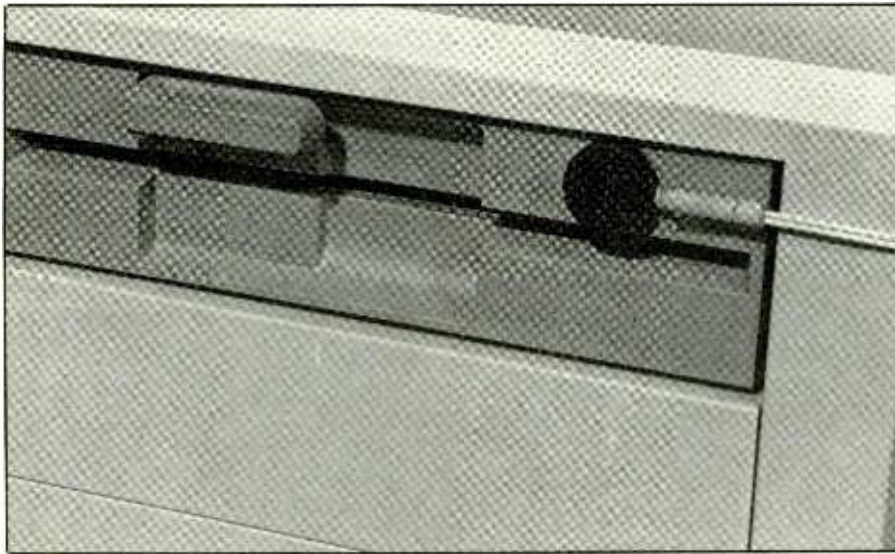

Fig. 4. Example of installation of photosensitive sensor over a floppy-disk drive's activity LED indicator.

ing excess cement into the washer's central hole and over the viewing surface of the transistor.

Lift the assembly from your work surface and check to make sure that the viewing surface doesn't project below the bottom surface of the washer. If it does, gently press it until it's flush with the bottom surface or is slightly recessed. Wipe from the perimeter of the assembly any excess cement and allow to set overnight.

For top-viewing detectors, such as the ECG 3036, drill a tight-fitting hole through a block of opaque plastic. Cement the detector into the hole with epoxy cement. Adjust the size and shape of the blocks of plastic to suit the particular installation.

For remote LEDs that project beyond the front surface of their mounting panels, mount the detector in a thicker block of plastic or cement additional washers to the detector assemblies.

Secure the phototransistor detectors over the LEDs in the equipment with which they are to be used with double-sided tape or a non-hardening putty like weather-strip caulking cord. If you use the latter, roll a pellet of the putty to form a thin strand.

Then form the strand into a circle around the sensor window.

Turn on the equipment with which the project is to be used so that the target LED is lit. Without touching the panel with it, position the sensor assembly over the lighted LED, moving it about until that channel's LED is illuminated on the project. Gently push the sensor into place to secure it to the equipment over the status LED. Do the same for all sensors.

When you're finished installing the sensors, label the front panel of the Status Indicator to reflect what equipment each channel's LED is monitoring. This way, you'll know at a glance the operating status of any given device in your system. Label the channels with a lettering kit, but omit any protective spray coating to permit the labels to be removed and replaced as you reconfigure your system.

You'll probably want to know when floppy-disk or hard-drive accesses are occurring. Modern drives run quietly, so brief disk access may go unnoticed. Though software utilities are available to sound the computer's speaker during disk access, the Remote Status Indicator pro-

vides a better alternative. It doesn't use up needed RAM in your computer or add to the items in your AUTO-EXEC.BAT file.

Just follow the procedure previously cited. Place a photodetector pickup over the floppy-disk (and/or hard disk) drive's LED. While the drive is running, carefully position the sensor so that its channel's indicator on the project lights. On subsequent disk accesses, adjust the level of the buzzer's tone to a comfortable level. If minimum level is excessive, tape over the hole in the buzzer. You can also operate the project with the audio-tone function disabled.

The utility of this project becomes more apparent when a device is farther away, of course, whether it's an external drive or whatever. For example, some printers don't have activity LEDs up front where they can easily be seen from your work position. If you forget to shut it off at the end of a long computing session, the photo sensor device will remind you. A status sensor placed over the printer's READY LED will also eliminate your having to remember whether or not you turned on your printer.

Keyboard NUM LOCK, CAPS LOCK and SCROLL LOCK status indicators are useful, but if you're a touch-typist, you may not notice their state as you type away while looking at source material. When using a word processor, it's easy to hit the wrong key and find that SCROLL LOCK or CAPS LOCK somehow kicked in and ruined your text. I chose to monitor the SCROLL LOCK LED because it's this function that has given me the most grief and, thus, required close watching. Monitoring keyboard keys requires that their LEDs be mounted separate from the keys themselves, of course.

Summing up, this project is an easy-to-build, low-cost accessory that can make it more convenient to operate a variety of systems from computer systems to remote-controlled stereo systems. **ME**

Car Windshield-Washer Low-Level Indicator

Lets you know when the level of washer fluid is getting low in ample time for you to replenish it

By Charles Shoemaker, Ph.D.

Some late-model cars include a dashboard warning light to alert the driver to a low level of windshield washer fluid. Now you can add this feature to your car with this simple, low-cost project. In addition to flashing a warning LED, it can optionally sound a tone from a speaker to give you time to add washer fluid before the reservoir runs dry.

Though originally designed to be used in a motor vehicle, this Fluid Level Indicator can be used to warn of low water level in a cistern, well or any other application where it is important for you to know when the

water has dropped to a certain level and you must take action.

About the Circuit

Shown in Fig. 1 is the schematic diagram of the basic Fluid Level Indicator circuit. This circuit is built around a ULN2429 fluid (moisture) detector integrated circuit that was designed to warn of a low fluid level in a reservoir. This particular chip can be operated with a dc or an ac output state at pins 1 and 14 (see Fig. 2 for pinouts and internal details of this chip). The project makes use of the dc output by placing a capacitor (C1 in Fig. 1) between pin 12 of

IC1 and circuit ground. The value of this capacitor must be fairly large, such as the 220 microfarads specified in the Parts List, to keep the ripple frequency of the chip's oscillator from appearing in the output.

An advantage of using the ULN2429 fluid detector chip is that the liquid-sensor probes used as the detector are operated in an ac mode. This prevents electrolysis action (plating) at the probe contacts that might otherwise occur if dc were used.

Frequency of the oscillator section of IC1 is determined by the value of C2 connected across pins 5 and 7. With a 1-microfarad value for this capacitor, the frequency was ob-

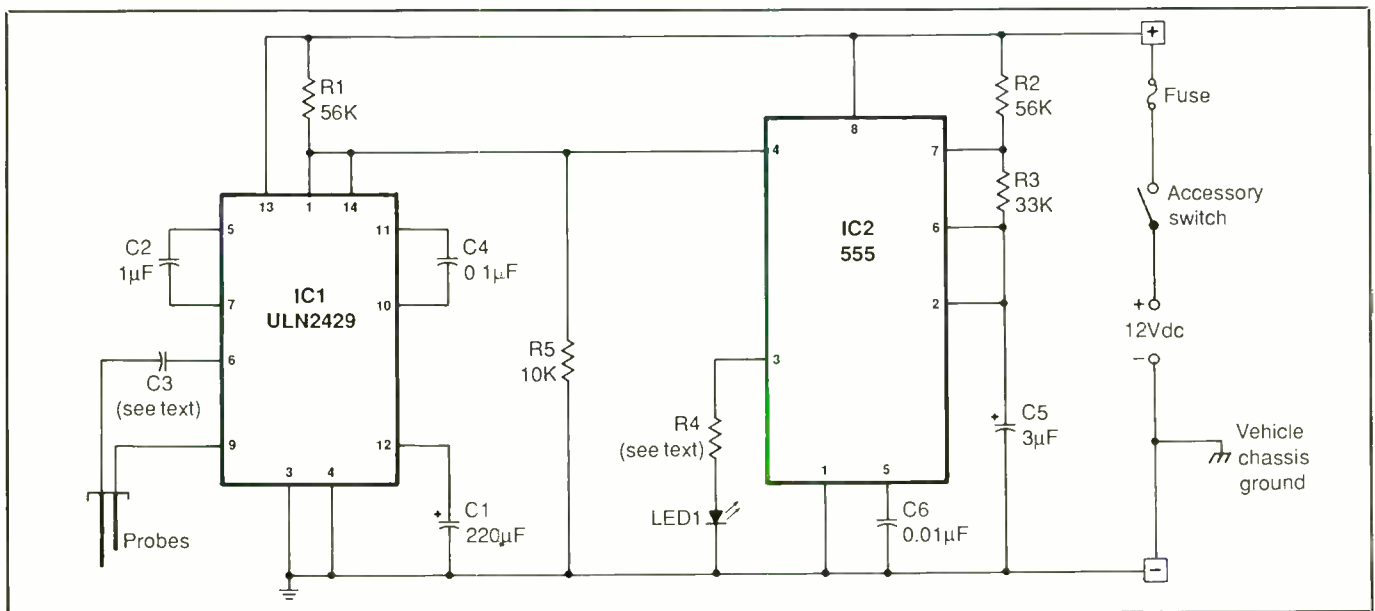

Fig. 1. Schematic diagram of visible LED-alert circuit.

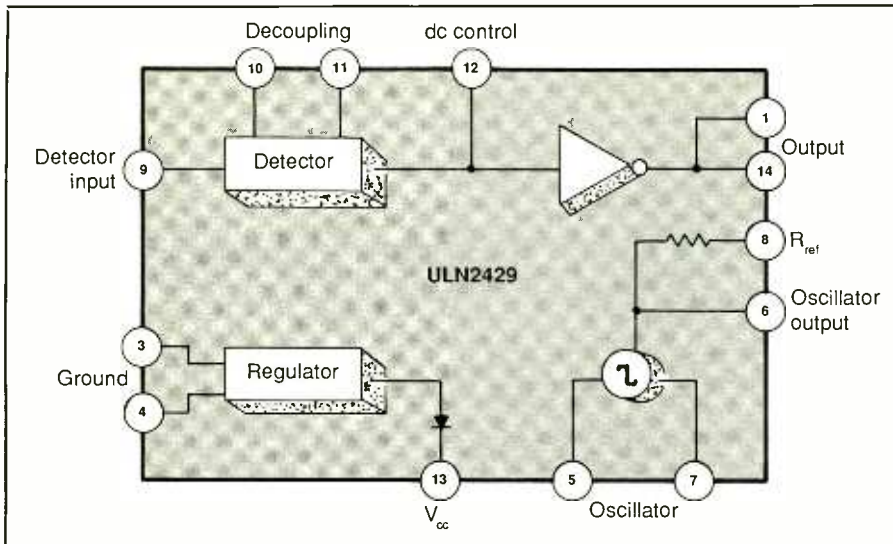

Fig. 2. Pinouts and internal details of the ULN2429 fluid-detector integrated circuit around which this project is built.

PARTS LIST

Semiconductors

IC1—ULN2429 fluid detector (DC Electronics, P.O. Box 3202, Scottsdale, AZ 85257)

IC2—555 timer

LED1—Amber or yellow light-emitting diode

Capacitors

C1—220- μ F, 35-volt electrolytic

C2—1- μ F, 100-volt ceramic disc

C3—1- to 5- μ F, 25-volt electrolytic

C4—0.1- μ F, 250-volt ceramic disc

C5—3- μ F, 25-volt electrolytic

C6—0.01- μ F ceramic disc

C7—220- μ F, 35-volt electrolytic (replaces R4 when tone-alert option is used—see text)

Resistors (1/4-watt, 5% tolerance)

R1, R2—56,000 ohms

R3—33,000 ohms

R4—390 to 470 ohms

R5—10,000 ohms

Miscellaneous

SPKR—2", 8-ohm speaker (replaces LED1 when tone-alert option is used—see text)

Printed-circuit board or perforated board with holes on 0.1" centers and suitable Wire Wrap or soldering hardware (see text); suitable enclosure; sockets for IC1 and IC2 (optional—see text); rubber grommets; heat-shrinkable tubing; machine hardware; stranded hookup wire; solder; etc.

served on an oscilloscope to be about 20 Hz. Increasing capacitance lowers the frequency, and decreasing capacitance raises frequency.

A pair of probes immersed in the fluid in the windshield-washer reservoir connect to the project by tying to pins 6 and 9 of IC1. The connection to pin 9 is direct, while that to pin 6 is through capacitor C3. (Note: The fluid into which the probes are immersed should have a resistance of 1,000 ohms or less between the probe elements.)

With the probes immersed in a liquid or physically shorted together, the oscillator section will be free-running. Under either condition, the dc output at pin 14 of IC1 is low and conduction through R1 produces saturation or a drop of about 11.5 volts. Notice that the output at pin 14 is directly connected to pin 4 of 555 timer IC2. The timer is disabled with 0.5 volt applied to pin 4, a condition indicated by LED1 being off.

When the level falls low enough to break the circuit between the probes as the washer fluid is used up, the oscillator output to the detector ceases and the potential at output pin 14 of IC1 rises to about 2 volts, with approximately 10 volts dropped across

R1. In turn, this rising voltage enables IC2, which oscillates and causes LED1 to flash. Thus, the flashing LED is a visible indicator that it is time to add windshield-washer fluid to the reservoir.

Current through LED1 is about 20 milliamperes at full on, about 10 milliamperes on average. Total current drawn by the entire circuit is about 35 milliamperes, which adds very little load to your vehicle's electrical system.

You can optionally equip the Fluid Level Indicator to sound an audible alert instead of flashing a LED when it is time to refill the reservoir. A simple modification of the basic circuit is all that is required. Details for this modification are given in Fig. 3. Firstly, change the value of the capacitor C5 connected between pin 2 of IC2 and circuit ground from its original 3 microfarads to 0.01 microfarad. Secondly, replace R4 and LED1 with a 220-microfarad, 15-volt electrolytic capacitor (C7 in Fig. 3) and a 2-inch 8-ohm speaker.

The circuit gets its power from your vehicle's electrical system. Since it requires power only while the vehicle is being operated, its +12-volt line wires to any point in the

electrical system that is energized when the ignition is turned on and is at 0 volt with the ignition off.

With the Fig. 3 modification in place, the circuit will sound a tone to alert you to a low fluid level condition instead of flashing a LED. If your vehicle's instrument panel is already crowded with visible indicators, the tone alert may be much the better way to go.

Further Study

If you wish to gain a better understanding of how the ULN2429 fluid indicator chip works, you can assemble the circuit shown schematically in

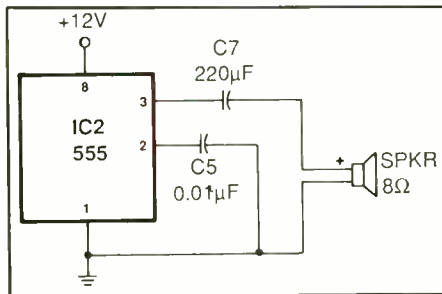

Fig. 3. Circuit details for optional tone alert.

Fig. 4 and install it in your vehicle as indicated. Instead of using the 555 timer shown for IC2 in Fig. 1, wire a general-purpose npn 2N2222 transistor into the circuit as shown to serve as the output device that drives the light-emitting diode.

Try removing C1 from the circuit and observe what happens. The LED should now flash at a rate of about 20 times per second as the output of the oscillator becomes an ac waveform. Your eyes may not be able to detect a 20-Hz flash rate; you will know that the LED is flashing by the fact that its intensity diminishes.

If you remove one of the probes from the liquid in which both are immersed, oscillations should cease. Now the LED should be full on with no indication of flashing. In this state, more power is consumed by the circuit. Of course, basic operation of this circuit is different from that of the project itself because an okay state will be indicated by a flashing LED (lower brightness). The alert to refill the reservoir, however, will be the same full-brightness of the light from the LED as is the case with the actual project.

You can use this circuit in a reverse application to alert you to the presence of water. In this application, the light from the LED would be in a steady-on mode, but when the water rises to a level where it touches both probes the light from the LED would diminish in intensity. This could provide a warning of water in your basement or in the bilge of a boat. For

this application, a green light-emitting diode is recommended for LED1.

Construction

There is nothing critical about assembly of this project. Therefore, you can wire it on a printed-circuit board or on perforated board that has holes on 0.1-inch centers using suitable Wire Wrap or soldering hardware. However, because the project will be used in an automotive environment, where it will be subjected to mechanical stresses, it is recommended that you use pc construction.

Use the actual-size etching-and-drilling guide shown in Fig. 5 to fabricate your printed-circuit board. Drill a 1/8-inch hole in each of four locations for mounting the board in the selected enclosure after wiring is complete and initial checkout has been performed. Drill these holes near the corners of the board to the left of where IC1 mounts and near where R3 and LED1 mount (Fig. 6).

When the board is ready, install sockets in the IC1 and IC2 locations, as detailed in Fig. 6. Sockets are optional but worth their small additional cost because they will speed troubleshooting the circuit should this ever become necessary. Do not plug

the ICs into the sockets until after you have performed preliminary voltage checks.

Next, install and solder into place the resistors, then the capacitors and, finally, the two jumper wires. Note that C1, shown phantom, mounts on the *bottom* or solder side of the board. The LED, probe cable and conductors for connection into your vehicle's electrical system will be installed later. Temporarily set aside the circuit-board assembly.

If you are planning to incorporate the speaker option into the project, do not forget to substitute a 0.1-microfarad capacitor for C5, omit R4 and LED1 and install C7 in place of R4, as detailed in Fig. 3.

For an enclosure, select a project box that will adequately accommodate the circuit-board assembly (and speaker if you are using it in place of the LED). Since there are no user controls, machining of the enclosure is a simple, straightforward procedure. Drill separate holes for the probe cable, both conductors that go to the vehicle's electrical system and the LED. If you are replacing the LED with the speaker option, drill a number of small holes in the enclosure in the area in which the speaker will be mounted to permit the sound to escape. Also, drill four holes for

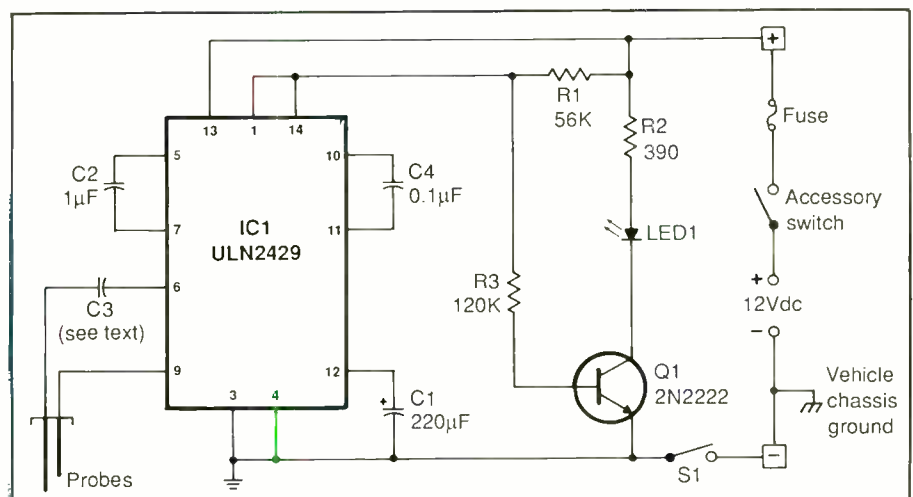

Fig. 4. Schematic diagram of a circuit that can be breadboarded to examine operation of the ULN2429 chip.

mounting the circuit-board assembly inside the enclosure and two more holes for mounting the enclosure in place inside the vehicle.

Light-emitting diode *LED1* can be mounted directly on one of the walls of the enclosure. If this is the case, size the hole for it accordingly. Alternatively, it can be mounted remotely and be interconnected with the circuitry inside the enclosure with a twisted-pair cable.

If you are using a metal utility box as the enclosure, be sure to deburr all holes and line those through which cables and conductors pass with rubber grommets.

Decide on a mounting location for the project. The LED version, can go inside the engine well or on, under or behind the dashboard. The audible-alert version must mount inside the vehicle. Cut to length the cables for connection to the vehicle's system, the probes and to the LED if it is to be remotely mounted. Use stranded hookup wire for all cables, preferably with red and black insulation for easy polarity identification.

Strip from both ends of all cables ¼ inch of insulation. Tightly twist together the fine wires in each conductor and sparingly tin with solder. Loosely twist together the two wires for each cable, making two to three turns per inch.

Pass the free ends of the cables through the grommets into the enclosure. Tie a strain-relieving knot in each about 4 inches from the free ends inside the enclosure. Plug the free ends of the probe cable into the holes labeled *TO PROBES*. Repeat for the LED cable and *LED1* holes (black conductor to hole *K* and red to the other hole if you are using color-coded wires) and the remaining and +12V (red insulation) and *GROUND* (black insulation). If the cables are not color-coded, use an ohmmeter or continuity checker to identify and label which is which at the opposite ends of the cables.

If you plan on mounting the LED

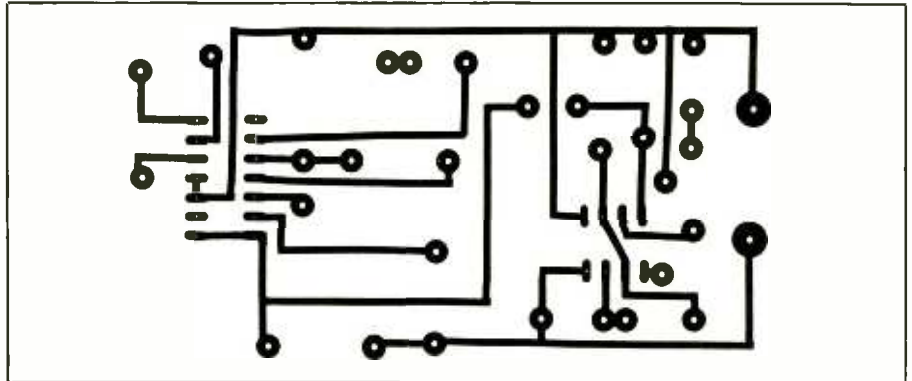

Fig. 5. Actual-size etching-and-drilling guide for printed-circuit board.

on one of the walls of the enclosure or are using the speaker option, strip ¼ inch of insulation from both ends of two 3-inch stranded hookup wires (preferably with red and black insulation). Twist together the fine conductors at all ends and tin with solder. Plug one end of each wire into the holes labeled *LED1* in Fig. 6 (black to the *K* hole) and solder them into place.

Use a thick bead of silicone adhesive to mount the speaker over the holes drilled for its sound to escape if you are incorporating this option into the project. Allow the adhesive to set undisturbed.

Connect the project's power cable to your vehicle's battery—observe polarity! Now clip the common probe of a dc voltmeter or multime-

ter set to dc volts to a convenient circuit ground, such as the lower lead of *C5* as viewed in Fig. 6. Touch the meter's "hot" probe tip to pins 1, 13 and 14 of *IC1*'s socket and pin 8 of *IC2*'s socket. If you do not obtain a reading of approximately +12 volts in all cases, disconnect the project from the battery and check all components for proper installation and your soldering for unsoldered or poorly soldered connections and solder bridges. Rectify the problem before proceeding.

When everything checks out okay, plug the ICs into their sockets. Be sure to properly orient them and make sure that no pins overhang the sockets or fold under between ICs and sockets as you push them home.

Mount the project box in the se-

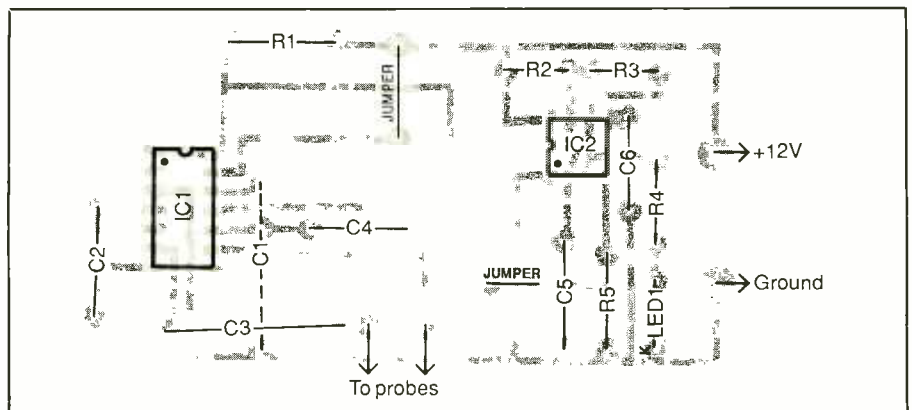

Fig. 6. Wiring guide for pc board for LED-alert version. For tone alert, replace *R2* and *LED1* with *C7* and a miniature speaker and change value of *C5*, as detailed in text. In both versions, *C1* mounts on bottom of board.

lected location. If you are mounting it with hardware, use self-tapping sheetmetal screws. First, however, set the enclosure in place and mark its mounting-hole locations onto the surface on which the project will be mounted. Drill a small hole in each marked location.

To provide a resilient mount for the project, place a flat washer on each screw and follow with a small rubber grommet. Plug the screws into the holes drilled for them in the enclosure and follow with another small rubber grommet on each screw. Drive the screws into the holes drilled in the vehicle's chassis, making them tight enough to compress the rubber grommets only slightly.

Mount the circuit-board assembly in place, using 1-inch spacers, 1¼-inch No. 4 screws, nuts and lockwashers. Check to make sure that none of the hardware touches any copper traces on the bottom of the board. If it does, place insulating fiber washers between the spacers and circuit-board assembly.

Assuming you are using the LED as the alerting device and that it is to be mounted on one of the enclosure's walls, slide a 1-inch length of small-diameter heat-shrinkable tubing over both ends of the LED's wires coming from the board. Mount the LED with a panel clip or fast-setting epoxy cement. Identify the cathode lead and trim it to ½ inch length, form a small hook in the stub and crimp it to the wire coming from hole K. Solder the connection. Do the same with the other lead and wire. Slide the tubing up over the connections to the bottom of the LED's case and shrink into place. A remotely mounted LED wires to the cable in exactly the same manner.

When wiring the speaker to the circuit-board assembly, crimp and solder the wire coming from the unidentified LED's hole to the speaker's "hot" lug, which may be identified with a "+" sign or a spot of paint. Crimp and solder the other wire

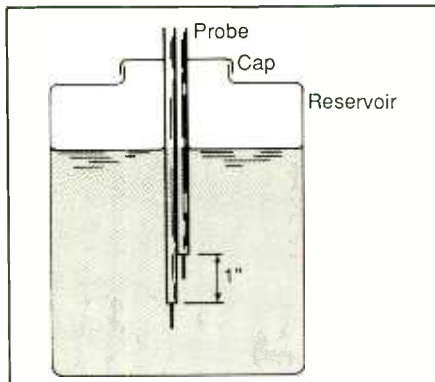

Fig. 7. Fabrication details for fluid probe assembly.

coming from the board to the other lug on the speaker.

Route the probe cable to the windshield-washer fluid reservoir. You can now fabricate the probe itself using any two parallel wires, such as zip cord, from which the insulation has been removed, as detailed in Fig. 7. Placement of the probes in relation to each other can establish a reserve after warning. For example, if one probe is cut so that it is 1 inch higher than the other, you will have a 1-inch reserve of fluid when the alarm LED flashes or the tone sounds before the reservoir requires refilling.

After trimming the probe wires to length, strip ¼ inch of insulation from both and the other ends of the wires. If you are using stranded wire or zip cord, tightly twist together the fine conductors at both ends and sparingly tin with solder. Then slip 1-inch lengths of heat-shrinkable tubing over both conductors of the probe cable and crimp and solder the free ends of the cable to the probe conductors. Slide the tubing over the connections and shrink it.

Drill a hole in the reservoir's cap and slide the probe assembly through it. Adjust the length of the probes so that the longer of the two will be about ¼ inch from the bottom of the reservoir with the cap in place. Make sure that the probe does not move as you seal the entry hole in the cap with silicone adhesive.

While the adhesive is setting, connect the power cable into your vehicle's electrical system. Choose any convenient metal surface of the vehicle that is at electrical ground to make the ground connection. Solder a ring lug to the free end of the ground wire and secure this in place with any grounded screw or drill a hole in a suitable location in the vehicle and secure the ground wire in place with a sheetmetal screw, using a toothed lockwasher to assure good electrical contact. Before making the connection, burnish the metal around the mounting location with fine emery cloth until the metal is bright and shiny.

Use a dc voltmeter or multimeter set to dc volts to determine where to make the +12-volt connection. The selected point must be +12 volts only when the ignition is on. There should be no power on the selected conductor with the ignition off. Suitable pick-off points are the leads to the radio and windshield-wiper motor. Insulate the connection with plastic electrical tape.

Now perform an operational check. Assuming the silicone adhesive has set, restore the cap to the washer-fluid reservoir. Then start your vehicle's engine. If the washer-fluid reservoir is full, the LED should be off or the speaker should be silent. If this is the case, simulate a low-fluid condition by uncapping the reservoir and withdrawing the probes from the fluid. The alarm LED should light or the speaker should sound a tone within a few seconds, indicating that all is okay. If not, you will have to troubleshoot the project and your external wiring to correct whatever is causing the problem.

This circuit was tested with commercial blue antifreeze windshield-washer fluid (methyl alcohol), tap water and tap water with detergent added. Performance was good in all cases. Therefore, you should have no difficulty getting it to work. **ME**

Vehicle Theft-Deterrent Device

Solid-state device disables your vehicle to simulate an ignition-system problem when a thief attempts to drive away your car

By Anthony J. Caristi

According to the FBI, more than 1.2-million vehicles were stolen in 1987, representing a steadily increasing theft rate of almost epidemic proportion. It's no wonder that the sale of auto-theft alarms is at an all-time high—to half-a-billion dollars a year. Savvy thieves know how to defeat many of them, though, so most commercial alarms do not prevent a thief from driving away a vehicle. Our Vehicle Theft-Deterrent Device does not prevent unauthorized entry or starting of your car. In fact, it allows a thief to drive it for a few seconds, but then cuts power to the ignition and causes a stall that simulates a serious problem with the ignition. The thief will then hightail it for safer pastures rather than try to “repair” the car.

You may be sure that the Vehicle Theft-Deterrent Device can be used in concert with an ordinary audible alarm. A thief might defeat the audible alarm, thinking that he has outsmarted you, which makes the stall seem even more like a legitimate ignition problem.

About the Circuit

Shown in Fig. 1 is the complete schematic diagram of the Vehicle Theft-Deterrent Device. As you can see, this is a fairly simple logic circuit, which is followed by a timer and an electronic switch. The logic portion of the circuit is composed of *IC1*, a CMOS 4011 quad 2-input NAND

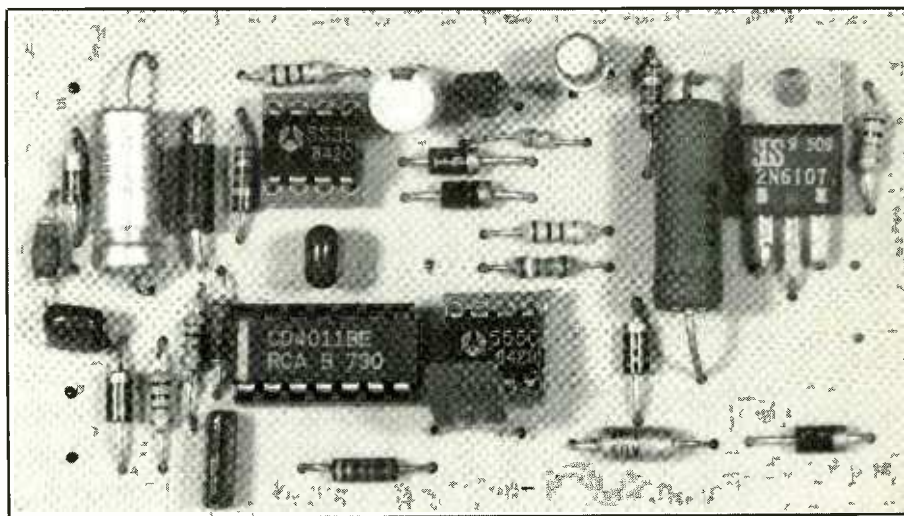

gate chip. Only three of the four gates in this IC are used here. The timer portion of the circuit is built around 555 timer chip *IC3*, and the electronic switch is composed of the Darlington arrangement made up of *Q1* and *Q2*.

Gates *IC1A* and *IC1B* are wired in a bistable multivibrator (flip-flop) configuration. This type of circuit has two stable states, which particular state it assumes depending on the logic levels fed to input pins 1 of *IC1A* and 6 of *IC1B*. The input at pin 1 of *IC1A* is connected to any source in the vehicle, such as the radio, windshield-wiper motor, etc. lead, that is at +12 volts when the ignition is turned on and is disabled when the ignition is turned off. On the other hand, the pin 6 input of *IC1B* must be permanently connected to a point in the electrical system that is at +12 volts regardless of whether the igni-

tion is on or off. Of course, the project's ground lead must be permanently wired to any good electrical ground in the vehicle.

With the circuit wired into the vehicle's electrical system as described, the +12 volts applied to pin 6 of *IC1B* through diode *D1* and resistor *R2* places a continuous logic 1 on this gate input. Momentary-action TEST switch *S1* is briefly closed to set the logic level at pin 6 to 0 to disable the project when an authorized driver takes the wheel.

When the vehicle is parked and its ignition is off, the logic 0 fed to pin 1 of *IC1A* causes the output of this gate at pin 3 to assume a logic 1 condition. The circuit remains in this state until you wish to operate your vehicle again, at which time you must briefly press and release *S1*. Under these conditions, the *IC1A/IC1B* flip-flop serves as a “memory”

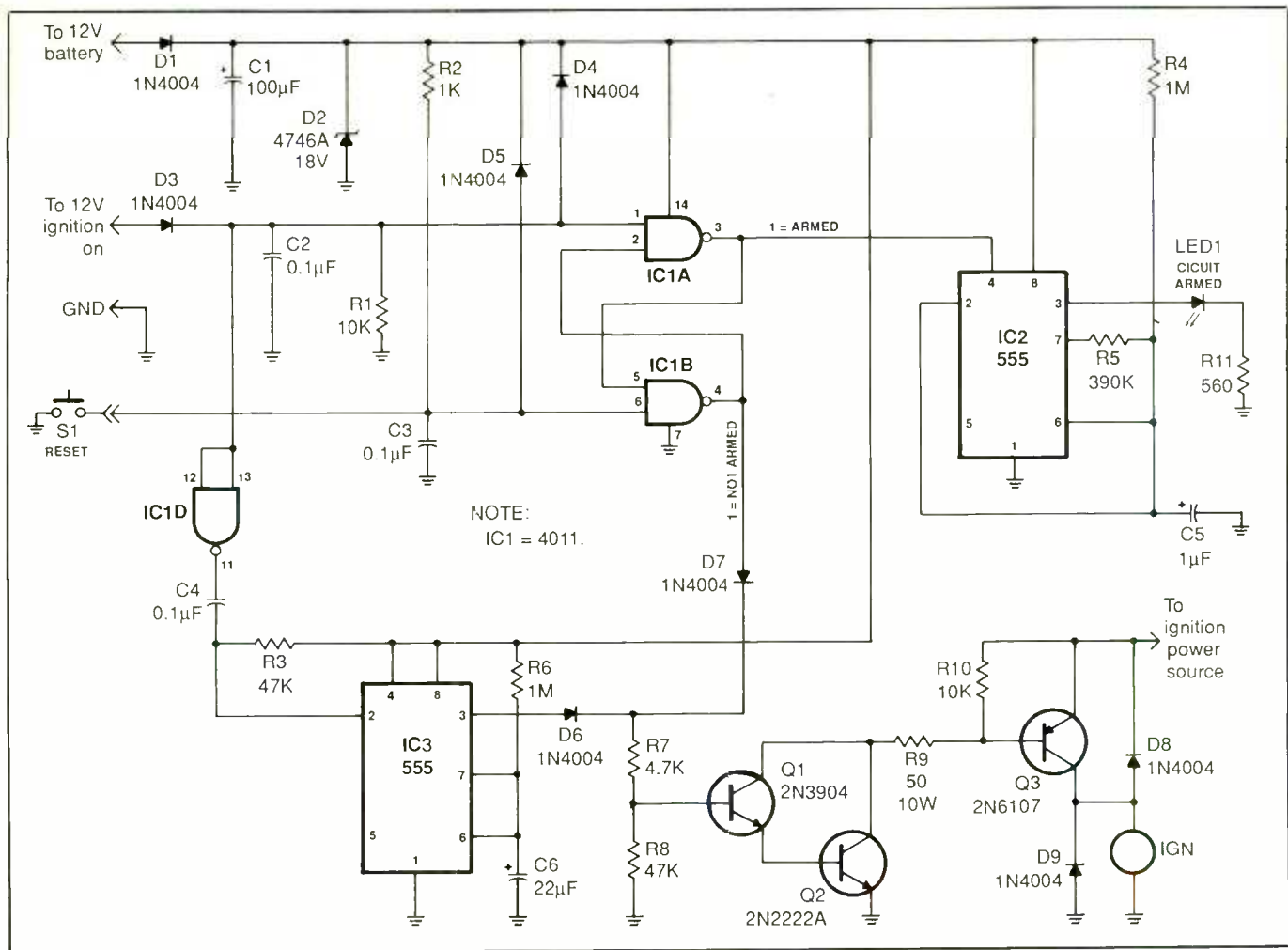

Fig. 1. Complete schematic diagram of the Vehicle Theft-Deterrent Device.

that automatically remembers when the vehicle is stopped and parked. This "armed" condition is visually indicated by light-emitting diode *LED1*, which flashes at a rate of about once every second. The flash and its rate are determined by the RC elements and *IC2* 555 timer chip. This timer is wired as an astable or free-running multivibrator.

When you wish to operate your vehicle, you turn on its ignition and then, within about 20 seconds, press and release the RESET switch to disarm the project. This causes the output at pin 3 of *IC1A* to assume a logic 0 condition. With the circuit disarmed, *LED1* extinguishes, thus serving as a visual indicator that you

can safely drive your vehicle away. The circuit will remain in this disarmed state until the ignition is turned off again after you park. The project then automatically arms itself.

Should a would-be thief defeat the ignition lock and start the vehicle's engine, the logic 1 condition at the cathode of *D3* (inverted by *IC1D*) applies a negative-going trigger pulse to pin 2 of *IC3*. This 555 timer is wired as a monostable or one-shot multivibrator with a timed cycle of about 20 seconds.

When the engine is started and the circuit is not reset by pressing and releasing *S1*, the output of *IC3* at pin 3 forward biases the Darlington arrangement made up of *Q1* and *Q2*.

When this occurs, *Q3* conducts and feeds the required power to the vehicle's ignition system. However, the source of power to the ignition system is applied for only the duration of the *IC3* timer circuit's countdown, or about 20 seconds.

When the countdown times out, the output from *IC3* causes the electronic switch to turn off. This disconnects power from the ignition system and causes the vehicle to come to an abrupt halt.

During authorized operation, when the RESET switch has been operated within the specified time after the ignition switch is turned on, the logic 1 output at pin 3 of *IC1A* is routed through *D7* to the base of *Q1*,

PARTS LIST

Semiconductors

D1, D3 thru D9—1N4004 silicon rectifier diode

D2—1N4746A or similar 18-volt, 1-watt zener diode

IC1—CD4011BE quad 2-input NAND gate

IC2, IC3—LM555CN timer

LED1—Jumbo red 2-volt, 20-mA light-emitting diode

Q1—2N3904 or similar npn silicon transistor

Q2—2N2222A or similar npn silicon transistor

Q3—2N6107 or equivalent npn silicon power transistor

Capacitors (25 WV)

C1—100- μ F electrolytic

C2, C3, C4—0.1- μ F ceramic disc or Mylar

C5—1- μ F ceramic or electrolytic

C6—22- μ F electrolytic (see text)

Resistors ($\frac{1}{4}$ -watt, 10% tolerance)

R1, R10—10,000 ohms

R2—1,000 ohms

R3, R8—47,000 ohms

R4, R6—1 megohm

R5—390,000 ohms

R7—4,700 ohms

R9—50 ohms, 10 watts

Miscellaneous

S1—Momentary-action, normally-open spst pushbutton switch

Printed-circuit board; DIP sockets for ICs; suitable enclosure (see text); 16-gauge or larger cable (see text); heat-shrinkable tubing; plastic electrical tape; suitable machine and sheet-metal hardware; stranded hookup wire; solder; etc.

Note: The following items are available from A. Caristi, 69 White Pond Rd., Waldwick, NJ 07463: Ready-to-wire pc board, \$9.95; CD4011BE, \$2.25; NE-555CN, \$1.75 each; 2N6107, \$3.50; 50-ohm, 10-watt resistor, \$3.00; 1N4746A, \$2.00. Add \$1.50 P&H. New Jersey residents, please add state sales tax.

which keeps the electronic switch on and, thus, applies continuous power to the vehicle's ignition system.

Warning LED1 provides visual indication that your anti-theft system is armed and that you must reset the circuit after the vehicle's ignition is turned on. As pointed out, you have about 20 seconds to press and release S1 before the ignition becomes disabled and your vehicle stalls out. Hence, the flashing warning LED might serve as an additional deterrent to a potential thief who cannot reset the circuit even though the RESET switch has been pressed unless the ignition switch is first turned on.

Construction

Because this project is designed to be used in an automotive vehicle, where it will be subjected to mechanical vibrations, it is recommended that you assemble it on a printed-circuit board. You can fabricate your own board using the actual-size etching-and-drilling guide shown in Fig. 2. Alternatively, you can purchase a

ready-to-wire pc board from the source given in the Note at the end of the Parts List.

As you can see, the circuit-board assembly will be small enough to easily conceal inside the engine compartment or up under the dashboard of the vehicle in which it is installed.

Once you have the pc board ready for component installation, refer to the Fig. 3 wiring guide. Though they

are not essential to circuit operation, it is recommended that you use best-quality sockets for the integrated circuit. The circuit is reliable and should require no attention during the life of the vehicle in which you install it. However, use of sockets will simplify troubleshooting the circuit should this ever become necessary and facilitates the checkout phase of project construction.

Begin wiring the pc board by installing and soldering into place the three DIP IC sockets. Use a fine-pointed soldering iron and take care to avoid creating solder bridges between the closely spaced copper pads on the bottom of the board. Once the sockets are in place, proceed to installation of the resistors. Mount all resistors, except power resistor R11 flush against the board. Then mount R11 so that its body is about $\frac{1}{2}$ inch above the surface of the board to allow air to freely circulate around and cool it and to prevent the heat dissipated by this resistor from scorching the board.

You now have the option of changing the timing cycle of IC3 if you wish to extend or shorten the period of time during which the RESET switch must be pressed before the timeout period lapses and disables the ignition. The simplest way to do this is to change the value of C6,

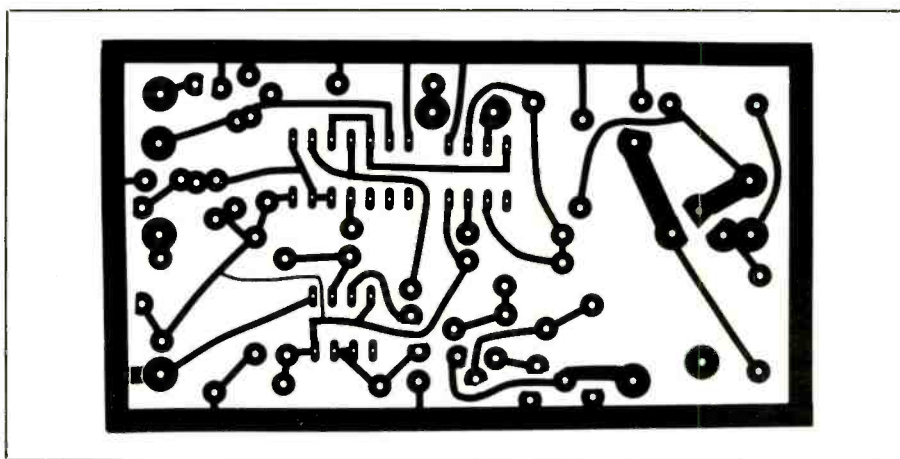

Fig. 2. Actual-size etching-and-drilling guide for pc board.

which at the specified 22 microfarads gives a period of about 20 seconds. Use a smaller value of capacitance here for a shorter period and a larger value to extend the period.

Since output transistor $Q3$ is saturated during normal vehicle operation, it dissipates very little power and does not require a heat sink. You can secure this transistor in place on the board, after soldering its pins into the appropriate holes, with a No. 4 machine screw, nut and lockwasher.

Continue wiring the board by installing and soldering into place the remainder of the components. Make absolutely certain that the electrolytic capacitors and diodes are properly polarized and that the transistors are properly based before soldering any of their leads to the pads on the bottom of the board. Also, mount $Q1$ and $Q2$ so that the bottoms of their cases are about $\frac{1}{4}$ inch above the surface of the board. Leave installation of light-emitting diode $LED1$ and RESET switch $S1$ for last, until you have decided where to locate them in relation to where the circuit-board assembly will be mounted. Also, do *not* install the ICs in their respective sockets until after preliminary voltage checks have been performed.

Checkout

The circuit can easily be checked out on your testbench before installation in your vehicle. To do this, use a 12-volt dc power supply that is capable of delivering at least 5 amperes of current or a 12-volt vehicle battery as the power source.

To simulate the ignition-system load on the circuit, use an ordinary 12-volt automotive parking or stop lamp, which draws about the same amount of current as the vehicle's ignition system. Wire this lamp to the circuit-board assembly using at least 16-gauge stranded wire.

To complete the test setup, you need a single-pole, single-throw toggle or slide switch to simulate the ignition switch and the normally-open,

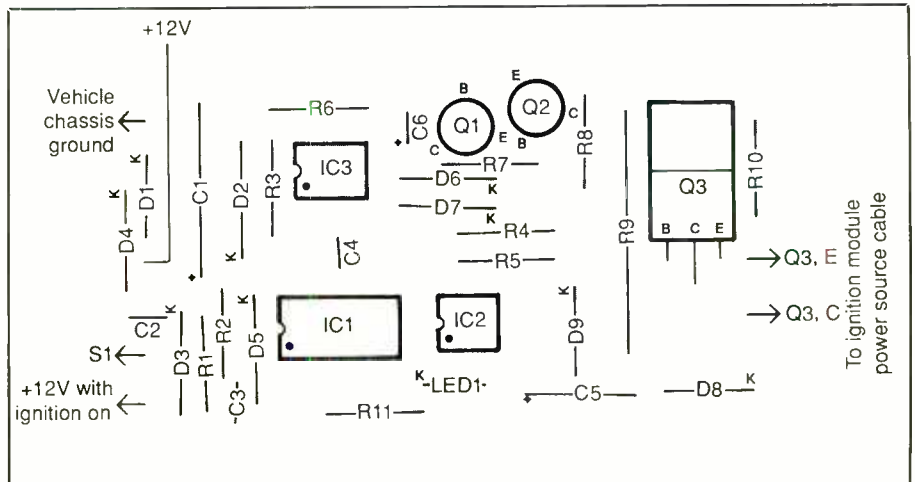

Fig. 3. Wiring guide for pc board.

momentary-action pushbutton switch specified in the Parts List for $S1$ to reset the circuit. Wire the power supply or battery, $S1$ and $LED1$ to the circuit-board assembly using ordinary No. 22 hookup wire, as illustrated in Fig. 4. Observe proper polarity! Before making the connection from the + terminal on the supply or battery to the ignition test switch, make sure the switch is set to its off position.

Turn on the power supply if you are using it instead of a battery and use a dc voltmeter or a multimeter set to the dc function to measure the potentials at the following IC socket points: pin 14 of $IC1$, pin 8 of $IC2$ and pins 4 and 8 of $IC3$. With the meter's common probe connected to circuit ground (the negative lead of $C5$ or $C6$ will do fine) and probing with the "hot" lead, you should obtain a reading at all four socket pins of +12 volts.

If you do not obtain the proper readings at the four IC socket pins, power down the circuit and check all component installations for proper devices in each location, proper orientations for polarity-sensitive devices, etc. Also check your soldering to make sure no cold-solder connections and no solder bridges exist. Do not proceed until you have corrected the problem.

Once you obtain the proper indications, power down the circuit and completely disconnect it from the dc power source. Then install the ICs in their respective sockets. Make sure each IC is properly oriented and that no pins overhang the sockets or fold under between ICs and sockets during installation. Also, handle CMOS $IC1$ with the same precautions you would use for any other MOS device to prevent it from becoming damaged by static electricity.

Set the ignition test switch to off and reconnect the power source to the circuit-board assembly. Observe proper polarity. Observe that the LED is flashing at a rate of about once per second, indicating that the circuit is armed. Throw the ignition test switch to on, as would occur if the project was installed in your vehicle and you were preparing to operate it prior to driving away.

Then press and release the pushbutton switch to reset the circuit. Do this within 20 seconds (or whatever time you decided to use if you changed the value of $C6$) of setting the ignition test switch to on. The LED should now extinguish as the reset action disarms the device. Also, the test lamp connected across the project's output should come on, indicating that power would be applied to the vehicle's ignition module.

Flip the ignition test switch to off, as you would do after parking your vehicle and prior to exiting it. The LED should immediately begin flashing as the circuit automatically arms itself. At the same time, the test lamp should extinguish when the period of IC3 times out.

Now simulate an attempt to steal your vehicle by toggling the ignition test switch to on without pressing and releasing the pushbutton switch within the allotted time. Note that the test lamp will come on, indicating that power is being delivered to the ignition system and that the vehicle's engine has started. At the end of the IC3 timing cycle, the lamp should suddenly extinguish. This is the point at which power would be removed from the ignition system and the engine would stall.

If you obtain the proper responses, the project can be installed in your vehicle, using Fig. 5 as a wiring guide. Otherwise, troubleshoot the circuit-board assembly to rectify any problem before proceeding to installation. For troubleshooting, use a digital dc voltmeter or the dc voltage function of a digital multimeter or an oscilloscope to check logic levels if you are not able to visually discover the cause of the problem.

The first step in troubleshooting the system is to determine if the bistable section composed of IC1A and IC1B is operational by controlling the logic levels at pins 1 and 6 with the two test switches. To reset the circuit so that LED1 extinguishes, you must first apply a logic-1 voltage to pin 1 by placing the ignition test switch in its on position. Operating the RESET pushbutton switch forces the output at pin 3 of IC1A to 0 volt, inhibiting IC2.

If the IC2 oscillator circuit fails to operate properly with the ignition test switch set to off, check pin 4 of IC2 to ascertain that the circuit is enabled by +12 volts from pin 3 of IC1. Also, check the condition of the light-emitting diode to make sure it is

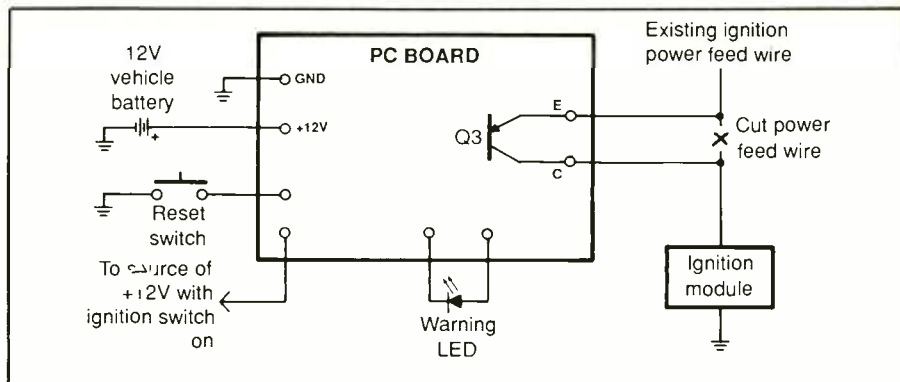

Fig. 4. Test setup for preliminary checkout of assembled project.

connected into the circuit in the correct polarity and that it is not bad.

Operation of the IC3 oscillator can be checked by momentarily shorting pin 2 to ground while measuring the voltage on pin 3. When you short pin 2 to ground, the potential on pin 3 should rise to about +12 volts, remain at this level for the timed period and then fall to 0 volt.

If the test lamp does not operate as described above, check the wiring of Q1, Q2 and Q3 and the orientation of D6 and D7. Make certain that the transistors have been properly based during installation. Also, check orientation of diodes D8 and D9.

Installation

You can mount the circuit-board assembly anywhere in your vehicle where it will be hidden from view and protected against tampering. This can be inside the engine compartment or up under the dashboard. The former is the better location in terms of security, especially if your vehicle is equipped with a tamper-resistant hood lock. In either case, you should house the circuit-board assembly inside a well-ventilated metal enclosure or a plastic enclosure that has a metal lid.

Machine the enclosure for board mounting hardware, exit holes for the wires that go to the vehicle's electrical system, the LED and pushbutton switch and two holes for mount-

ing the project in place. Use just one hole for exit of the four wires that attach to the left end of the board and the WARNING LED as viewed in Fig. 5 and a separate hole for the two wires (or two-conductor cable) that attach to the EMITTER and COLLECTOR pads of Q3. Drill the mounting holes for the circuit-board assembly in the top section of the enclosure.

After machining the enclosure, deburr all holes and then line the ones for wire exits with small rubber grommets. Next, determine how long the wires must be to bridge from the mounting location to the various points in the vehicle's electrical system and cut them to length.

Use No. 22 stranded hookup wire for the +12V, GND, RESET switch, WARNING LED and +12V WITH IGNITION ON conductors. For the Q3 EMITTER and COLLECTOR wires that go to the vehicle's ignition system, you must use 16-gauge or heavier two-conductor stranded cable to handle the heavy load current.

Strip from both ends of all conductors about ¼ inch of insulation, except strip ½ inch of insulation from one end of each of the 16-gauge wires. Tightly twist together the fine wires at all conductor ends and sparingly tin with solder.

Feed one end of the No. 22 wires through its grommet-lined hole and

(Continued on page 90)

Phone-Line “Busy” Indicator

Lights a LED to inform others when you are using your modem

By Robert M. Harkey

After getting a modem for my computer, I soon discovered that a “busy” indicator for my telephone line was an absolute necessity. Several times while I was downloading files, members of my household picked up an extension instrument and created havoc with my data. I had to find a way to prevent this from happening again. Of course, I could have gotten a dedicated line installed just for using my modem, but I did not want to incur the extra monthly charges. Therefore, I devised the circuit shown in the schematic diagram to warn family members not to pick up the phone while I was on modem.

Connected across the telephone line in the polarity indicated, my simple circuit serves as a visual warning indicator whenever I’m using my modem. The visual device used is light-emitting diode *LED1*.

Input impedance to the indicator is very high as a result of 2.2-megohm resistors *R1* and *R2*. Therefore, the circuit should be virtually undetectable on the phone line and will not interfere with normal operation of any instrument connected to the line. Operation is completely automatic. As soon as the modem accesses the line or the receiver of any instrument connected to the line is taken off-hook, *LED1* lights. Conversely, as soon as the modem disconnects from the line or the receiver is hung up, the LED extinguishes.

This circuit is powered by 3 volts

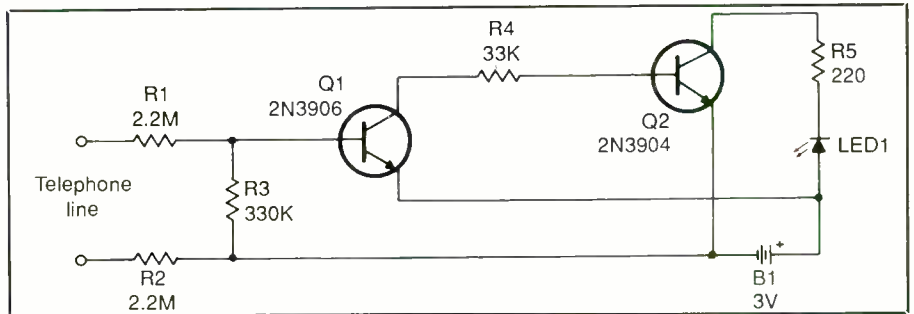

Self-powered circuit connects across telephone line and lights a LED to signal when a modem is on-line or a telephone instrument is off-hook.

dc from battery *B1*, which consists of two AA cells in series. Fresh cells should last between six months and a year, depending on how often and how long the phone is in use during a given period.

Because of its simplicity, you can build this circuit on a small piece of perforated board or project board. Alternatively, you can design and fabricate a printed-circuit board on which to assemble it. If you wish, you can house the circuit inside the telephone instrument, with the LED mounted externally or in a hole drilled in the instrument’s case. If you go this route, make absolutely certain to fully electrically insulate the circuit from all internal instrument circuitry.

If you wish, you can house the circuit inside its own plastic enclosure,

again with the LED visible from the outside. Whichever method you use to build the circuit, equip it with a modular connector for connection to the telephone line. This is an FCC requirement for all accessory devices that connect to the telephone line. If there is only one wall jack at the location where you plan to use the circuit, use a one-to-two-jack adapter so that the telephone instrument and indicator circuit can be plugged into the telephone line simultaneously.

If your household has more than one telephone instrument connected to the phone line, build a separate indicator device for each. Then inform all members of your household what the little red light indicates when it is on. You will find that this simple circuit will make using your modem a lot less aggravating. **ME**



Programmable Light Controller

(Part I)

This illumination "computer" can be programmed to enhance holiday light displays with sequencing, flashing and twinkling effects

By David Miga, CET

If your neighborhood is like mine around Christmas time, lots of people compete for the best light show in town. Countless strings of colored light bulbs blink away, enlivening mechanical reindeer, decorating trees, doors, even the whole house. The most elaborate setups often wind up being pictured in the local newspaper and sometimes on local TV news.

To reach for these "prizes," a former employer asked me to design and build him a digital light control computer. My model EDS-63 was the result, which is a programmable light controller that got his house featured in live motion on a Miami TV station last Christmas! Its sophisticated capabilities might do the same for you, as well as producing an enthralling light show when you're throwing a party, enlivening a discotheque, captivating retail customers with exciting lighted store signs, etc.

You've doubtlessly seen simple sequencing lights in a variety of places. Our Programmable Light Controller provides totally different results right up to the most ingenious theatrical light effects. Moreover, its component cost of around \$200 is only a fraction of a commercial equivalent's price.

For starters, our Controller has 10 different programs. The speed of each is individually controllable for the most appealing effect. The Controller automatically switches from program to program at a rate you se-



lect. Any given program can be "frozen" to repeat itself indefinitely on demand. Thus, this Controller is particularly suitable for holiday-season light displays. With it, you can set colored lights to chasing each other, flashing and twinkling, even creating an eye-catching "starburst" effect. The range of effects is limited only by your imagination, the number of light strings you use and how you arrange the lights.

Five separately fused output channels accommodate the strings of lights. Each output channel can handle up to 1,000 watts, which should be more than adequate for home dis-

plays. For creating high-power commercial and theatrical light effects, the basic 5,000-watt project can optionally be made to handle up to 12,000 watts of power! It can also be adapted to control motors, depending on your expertise in this area.

About the Circuit

Because of its complexity, the schematic diagram for the Light Controller is shown here in six parts, both to fit it all in and to break down the circuit into subsections that are easier to discuss and follow.

Figure 1 is the schematic diagram

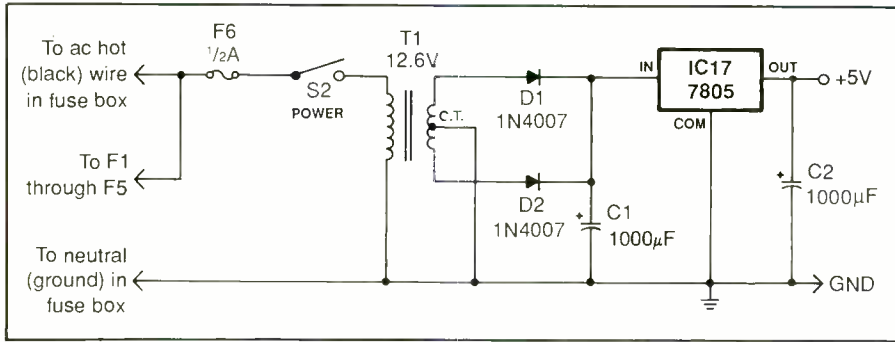

Fig. 1. Schematic diagram of project's simple regulated 5-volt dc power supply.

of the system's simple regulated dc power supply. Incoming ac line power is stepped down to 12.6 volts ac by power transformer *T1*. This low ac voltage is rectified to pulsating dc by *D1* and *D2* and is filtered to dc by *C1*. This dc voltage is then regulated by *IC17*, whose output is further filtered by *C2*. Except for the direct ac-line power that goes to the lamp-driver circuits, the entire project is operated from this power supply.

One of the two oscillators used in this project is the step oscillator shown schematically in Fig. 2. It consists of 555 timer *IC5* and its associated components. Wired as an astable oscillator, *IC5* outputs a signal whose frequency is adjusted by speed potentiometers *VR2* through *VR11* (see Fig. 3). These speed pots vary

the frequency of each program and are electronically selected.

The 555 oscillator feeds decade counter *IC3* and decimal decoder *IC1* to provide a sequenced source of active pull-down outputs on ROW 0 through ROW 9. This circuit provides each program with 10 different steps and forms a 10-line bus that feeds data-selector chips *IC7* through *IC16* in Fig. 4 through programming diodes *D18* through *D212* in Fig. 5.

Figure 4 is a simplified diagram of a 10-stage system of circuits, with only the first and last circuits shown. The other eight circuits not shown are identical to those that are except for the programming-diode matrices (Fig. 5 shows individual stage details for these) and the fact that only two of the five transistor/triac load-driv-

er circuits are shown connected to the lower five-line bus. Note that *R17* from the base of *Q1* connects to bus line 5 and *R21* from the base of *Q5* connects to bus line 1; *R18*, *R19* and *R20* from *Q2*, *Q3* and *Q4* connect to bus lines 4, 3 and 2, respectively to complete the circuit.

Taking note of the complexity of the diode programming matrices shown in Fig. 5, you might be wondering why an EPROM was not used instead of so many diodes, data-selector chips, etc. One reason is that most electronics hobbyists do not have easy access to an EPROM programmer. Another is that those people who would like to design their own programs can do so with just a small investment in inexpensive 1N914 diodes.

A careful examination of Fig. 5 will reveal how each diode matrix causes the system to sequence. For example, look at Program 5. Steps 0 through 9 start at the top of the bus and work their way down. Note how the diodes sequence from right to left and then to right again. Actually, the sequence is left to right to left, but the view shown is the reverse of actual "motion."

Now examine Program 6. Notice here how the diodes scan from left to

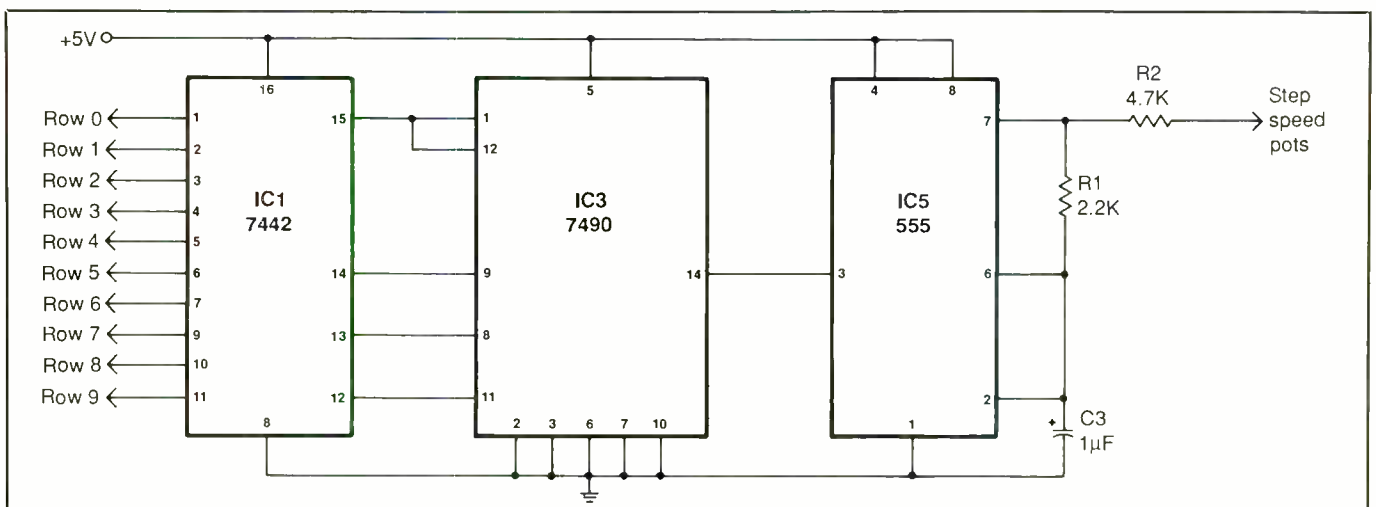

Fig. 2. This step oscillator is one of two oscillators used in the project.

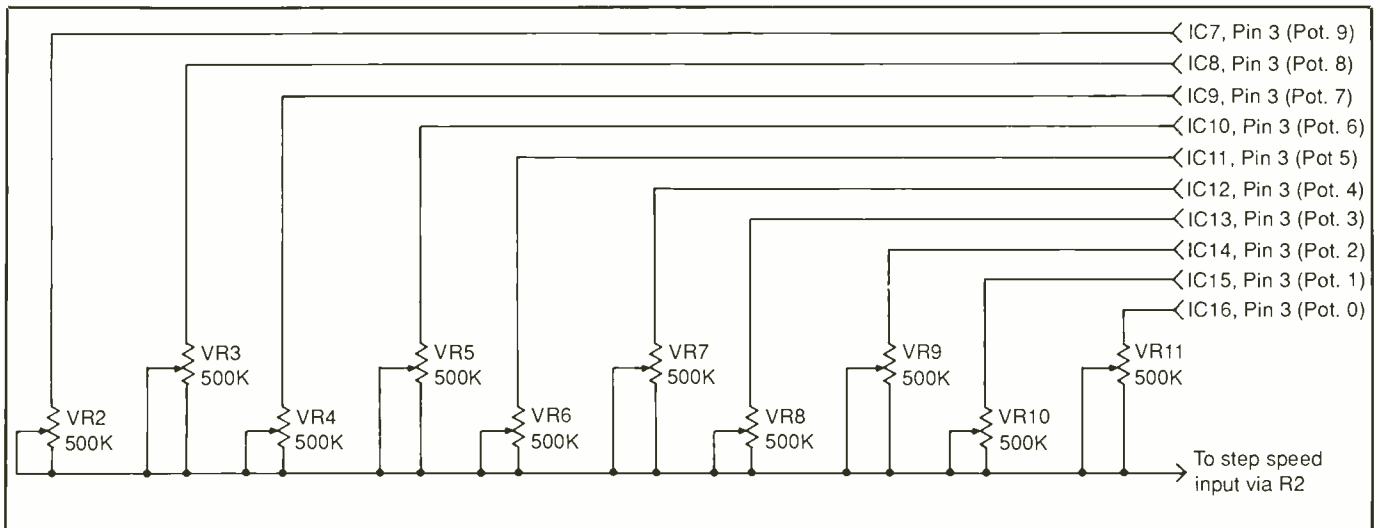

Fig. 3. Separate potentiometers provide the means for adjusting the speed at which each program runs.

right. The reason this sequence repeats itself is that there are 10 steps but only five output channels. Hence, the sequence runs twice.

Each program was designed to be independent of the others. However, the programs "flow" into each other. The following is a brief descrip-

tion of each program:

- **Program 0.** A sequence of three channels on and two channels off that runs in left-to-right motion. This is a negative sequence because a "dead spot" appears to move along the lit lamps.
- **Program 1.** This is a negative se-

quence that is identical to Program 0, except that the sequence is from right to left.

- **Program 2.** Like an accordion, this program starts with a single light lit in the middle of the display and then widens one lamp at a time until all channel lamps are on. It then extin-

PARTS LIST

Semiconductors

- D1 thru D17—1N4007, ECG 125 or similar 1,000-volt, 1-ampere rectifier diode
- D18 thru D221—1N914 or 1N4148 silicon switching diode
- DISP1—MAN4710A LED 7-segment numeric display
- IC1, IC2—7442 decimal decoder
- IC3, IC4—7490 decade counter
- IC5, IC6—555 timer
- IC7 thru IC16—74LS365 data selector
- IC17—7805 +5-volt regulator
- IC18—7447 7-segment decoder/driver
- Q1 thru Q5—2SB544 or similar 25-volt, 1-ampere, 1-watt pnp silicon transistor
- TC1 thru TC5—SC1-46M 400-volt, 12-ampere triac (or ECG 56006 triac—see text for modification); substitute ECG 56024 40-ampere triac in 12,000-watt version

Capacitors

- C1, C2—1,000- μ F, 25-volt electrolytic
- C3—1- μ F, 50-volt electrolytic

- C4—47- μ F, 16-volt electrolytic
- C5—0.047- μ F, 100-volt Mylar
- C6 thru C11—0.22- μ F, 100-volt Mylar
- C12—220- μ F, 16-volt electrolytic
- Resistors** ($\frac{1}{4}$ -watt, 5% tolerance)
- R1, R17 thru R21—2,200 ohms
- R2, R4—4,700 ohms
- R3—3,300 ohms
- R10 thru R16—220 ohms
- R22 thru R26—22,000 ohms
- R27—1,000 ohms
- R5 thru R9—100 ohms, $\frac{1}{2}$ -watt metal-oxide
- VR1 thru VR11—500,000-ohm, linear-taper potentiometer

Miscellaneous

- F1 thru F5—12-ampere 3AG fuse (25-ampere for 12,000-watt version)
- F6— $\frac{1}{2}$ -ampere, 3AG fuse
- L1 thru L5—Panel-mount neon-lamp with limiting resistor (optional)
- S1, S2, S3—Spst push-push, slide or toggle switch
- T1—12.6-volt, 1-ampere center-tapped power transformer

Printed-circuit boards; suitable enclosure (see text); holders for fuses (see text); pointer-type control knobs; ac receptacles (see text); red filter material; dry-transfer lettering kit; machine hardware; various sizes wire (see text); solder; etc.

Note: The following items are available from Electronic Design Specialists, 951 SW 82 Ave., N. Lauderdale, FL 33068 (305-726-2427): Main pc board with layout, \$35 plus \$3 P&H; display pc board with layout, \$4 plus \$1 P&H; kit of components to build 5,000-watt version pc-board assembly only (does *not* include enclosure, fuse holders, indicator lamps, switches, knobs, ac receptacles, and miscellaneous hardware), \$189 plus \$8 P&H; complete kit of all components with drilled and silk-screened Compulab enclosure with full instructions, \$389 plus \$10 P&H. Florida residents, please add state sales tax. Also available from Kepro Circuit Systems, 630 Axminister Dr., Fenton, MO 63026-2992 (800-325-3878): An actual-size plotted negative for shooting Kepro sensitized pc board.

guishes one lamp at a time back to the single middle one.

- **Program 3.** This program flashes all five channels on and off four times and then executes a quick three-channel sequence from left to right.

- **Program 4.** This program has a simple positive scan from left to right, similar to the action of a radio scanner.

- **Program 5.** This is a "zig-zag" program that scans left to right and back to left.

- **Program 6.** This is the reverse of Program 4, with a simple positive scan from right to left.

- **Program 7.** This program provides a scan sequence with a twist. It turns on outputs one at a time with all lights lighting sequentially until all five are active. It then turns off all outputs one at a time until all channels are off. Sequence is left to right.

- **Program 8.** This program creates a random "twinkling" light effect.

- **Program 9.** This is a "starburst" program in which all lights are off for a suspiciously long time and then suddenly all light simultaneously and then twinkle one by one at random until all is dark again.

Referring back to Fig. 4, data selectors IC7 through IC16 serve two purposes. One is selection of the outputs of D18 through D221 program by program. The other is to select the Fig. 2 speed pots individually so that each program can be adjusted to its most appealing speed for the light display. For example, the Program 9 (starburst) and Program 8 (twinkle) should both run at a slower speed than the negative sequences generated by Programs 0 and 1.

The enable pins of each data-selector IC, labeled E0 through E9, are selected by the circuit composed of IC6, IC4 and IC2 shown in Fig. 6. This second of the two oscillators used in the project is the program oscillator. It is slow and has its own speed pot, VR1, that can be set to display each program for a period of

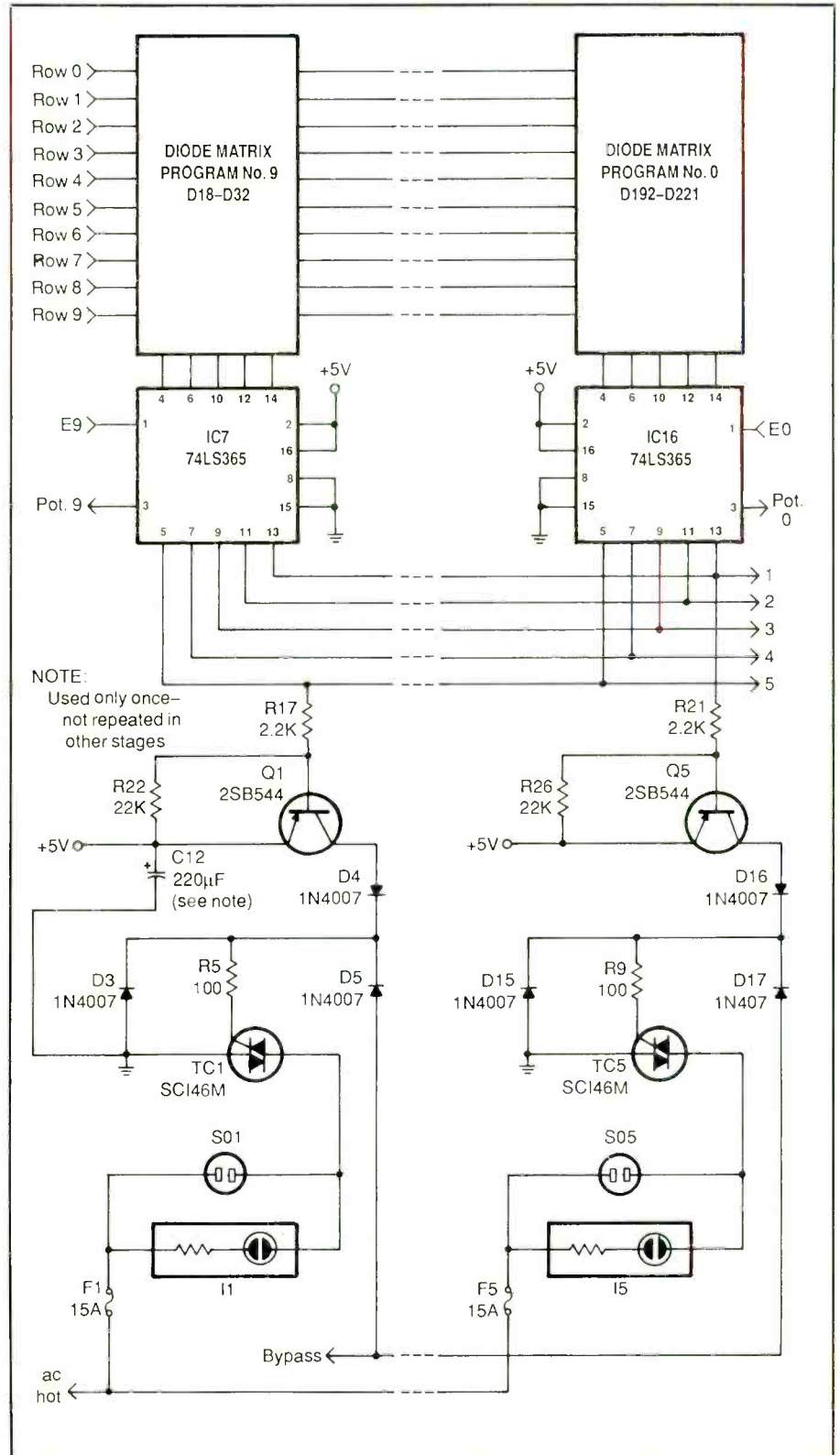

Fig. 4. Ten sections make up the data-selection and programming circuitry. Only the first and last sections are shown here. The other eight sections are identical and connect to the lower five-line bus in descending order.

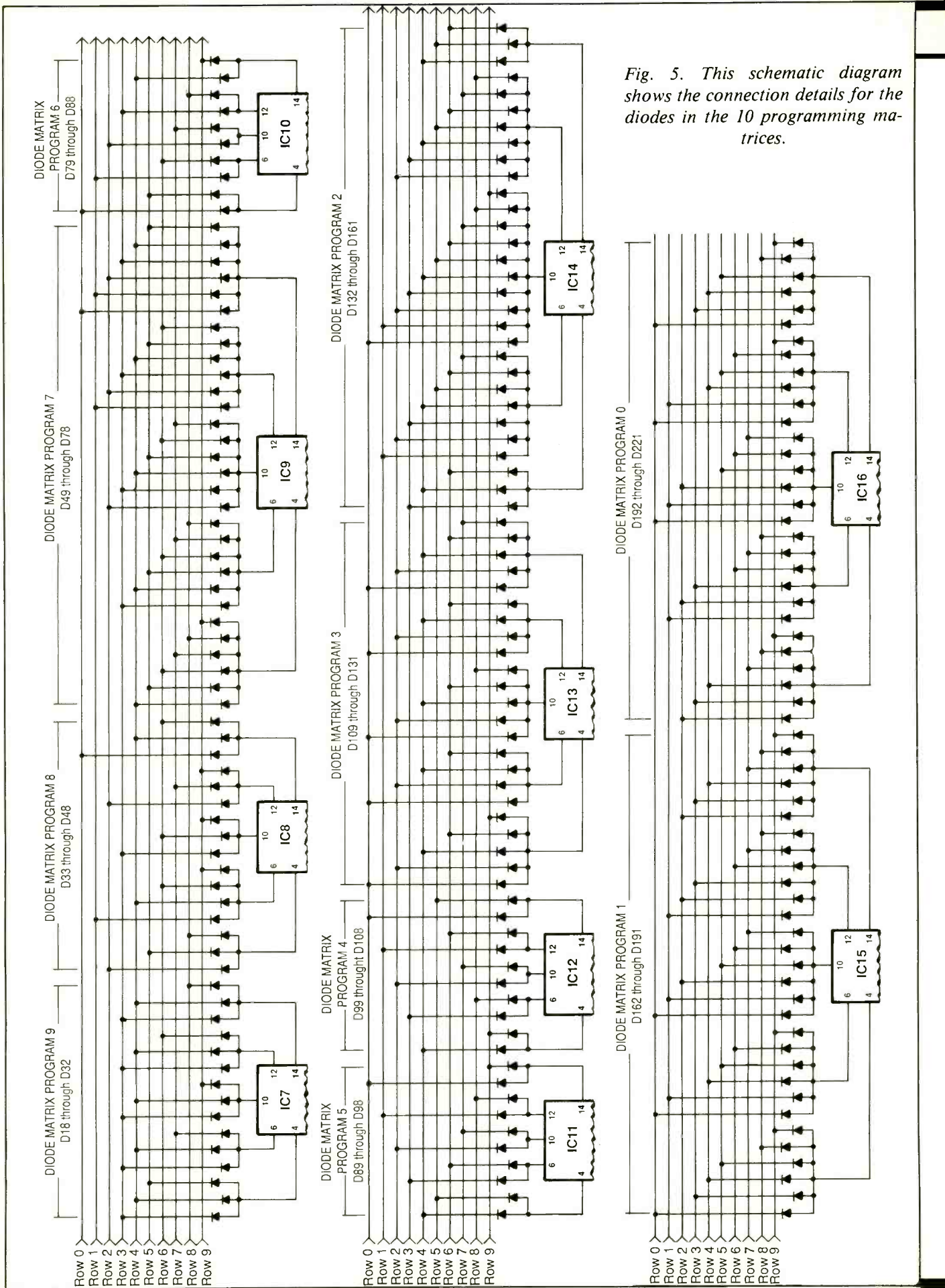

Fig. 5. This schematic diagram shows the connection details for the diodes in the 10 programming matrices.

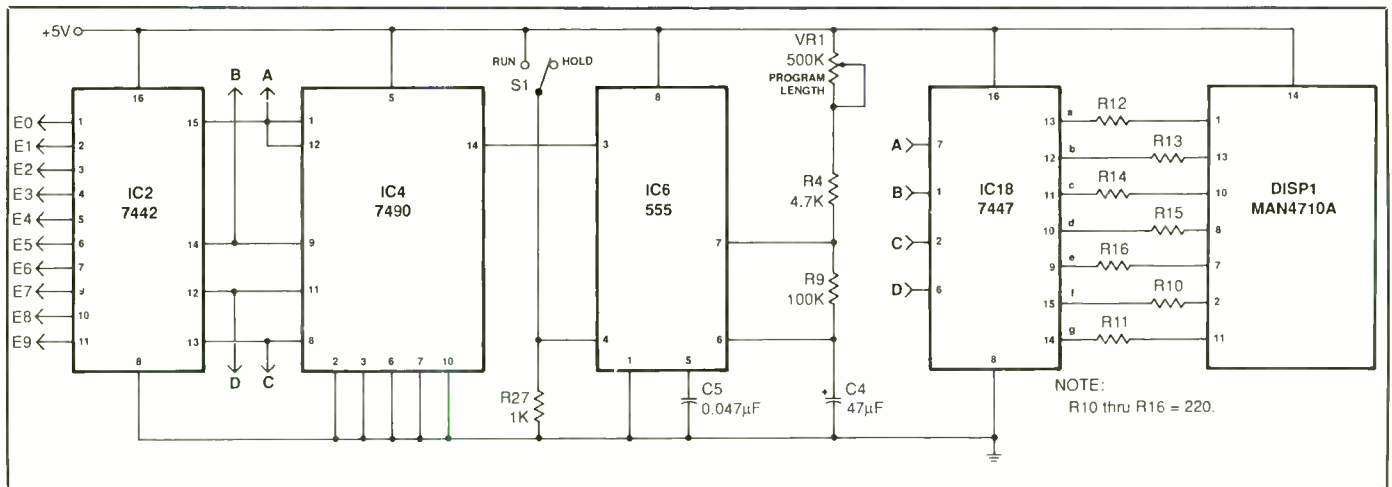

Fig. 6. This circuit keeps tabs on which program is running at any given time and displays its number on a large seven-segment LED display.

from 5 seconds to as long as 30 seconds each.

Also shown in Fig. 6 is a numeric-display circuit consisting of driver IC18 and seven-segment LED numeric display DISP1. This circuit displays the number of the program that is running at any given moment. It receives a binary-coded-decimal (BCD) signal from the A, B, C and D outputs on pins 12, 9, 11 and 8 of IC4. Contained within IC18 is all the circuitry needed to decode the BCD signal and drive the segments of the MAN4710A display device.

Each program can be halted by placing switch S1 in the HOLD position. This inhibits oscillator IC6. Note in Fig. 4 that each data-selector chip has a pin labeled with a legend that can be any number between POT0 and POT9. These are the outputs to each speed pot in Fig. 3. these pots are wired as simple rheostats, with one end of each joined in common and connected to the free end of R2 in Fig. 2.

The tri-state outputs of data selectors IC7 through IC16 connect to the lower five-line output bus in Fig. 4. Each of the Q1 through Q5 driver transistors receives its drive signal from a different line of the output bus. Each transistor amplifies and

directs the picked-off signal through protection diodes (D3 and D4 for the Q1 stage, for example) to its particular triac (TC1 for the Q1 stage).

The BYPASS function built into the project provides a means for checking for burnt-out lamps. This is done by applying a source of +5 volts to the bus line labeled BYPASS through a switch. The Parts List identifies this switch as S3, which wires into the circuit between the BYPASS bus and any convenient source of +5 volts. When in the BYPASS position, this switch powers all triacs through D5,

D8, D11, D14 and D17 to turn on all lamps simultaneously.

Because of the high-current capabilities of this project, ac line power is always applied to the triacs. However, none of the output receptacles (S01 through S05) will be active when the driving electronics is turned off. Hence, the only POWER switch is S1 in Fig. 1, used to direct ac line power to transformer T1.

This concludes the first installment of this article. Next month, we will finish up with construction, installation and checkout, and use details **ME**

NEW RUGGED PORTABLE FACSIMILE/COPIER

*Compact Cobra® Print Phone sends & receives hard copy over any phone line!
... doubles as photocopier*

SAVE \$200!
Introductory Price only \$1199!
Regularly \$1,399.95

Includes 2 paper rolls, ac & phone-line cords
Optional acoustic coupler for hard-wired phones (\$49.95), carrying case (\$39.95), extra paper rolls (\$6.95 ea.) & DC power inverter for 12V automotive

ORDER YOUR FAX/COPIER TODAY!
Send check or M.O. now; VISA or M/C ok. Add \$5 ship/handle (we pay rest). NY res. add sales tax

S-O-L-T-E-K E-N-T-E-R-P-R-I-S-E-S
P.O. Box 185, Merrick, NY 11566
(516) 378-4960

CIRCLE NO. 174 ON FREE INFORMATION CARD

Semianalyzer Revisited

Add signal-tracing and signal-injection to this versatile instrument

By David Miga, CET

Readers who built the Semianalyzer project featured in the April and May 1988 issues of *Modern Electronics* will find that the two simple modifications presented here will enhance an already versatile instrument. The signal-tracing and signal-injection fea-

tures described make possible more troubleshooting capabilities.

Signal Tracer

You will recall that the Semianalyzer checks semiconductor junctions in-circuit and analyzes the breakdown voltage and noise level of capacitors, resistors, semiconductors and other components. Since the Semianalyzer

already has a 3½-digit LED voltmeter, amplifier and all necessary filter/protection/alc circuits built into it, it is a simple matter to add a switch and resistor to transform it into a signal tracer.

The amplifier in the Semianalyzer can monitor an audio signal as low in level as the output of a magnetic phono cartridge yet can withstand up to 250 volts dc or audio signals up to

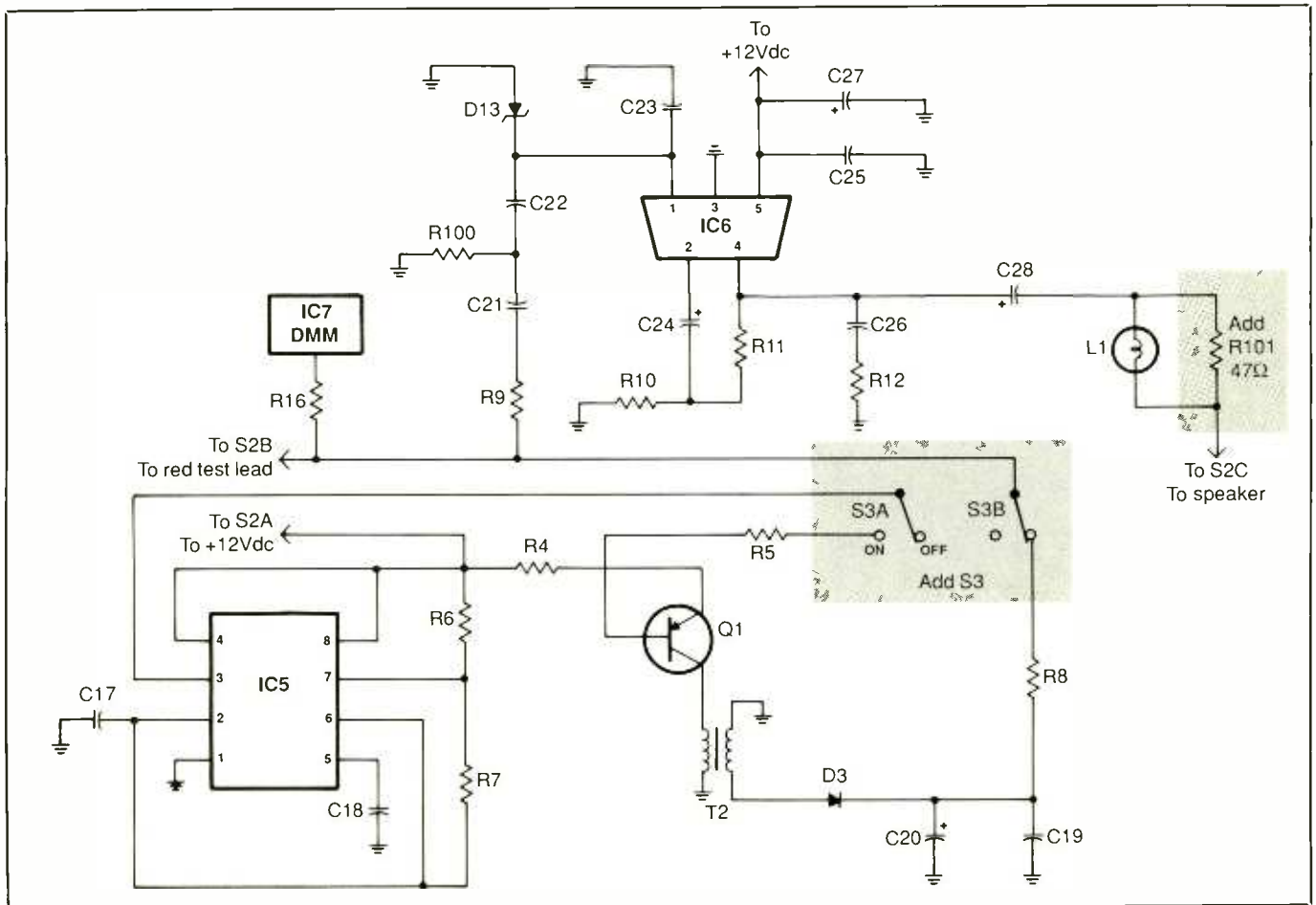

Fig. 1. Modification of Semianalyzer for signal-tracer function consists of adding dpdt switch S3 and 47-ohm resistor R101 to original circuit.

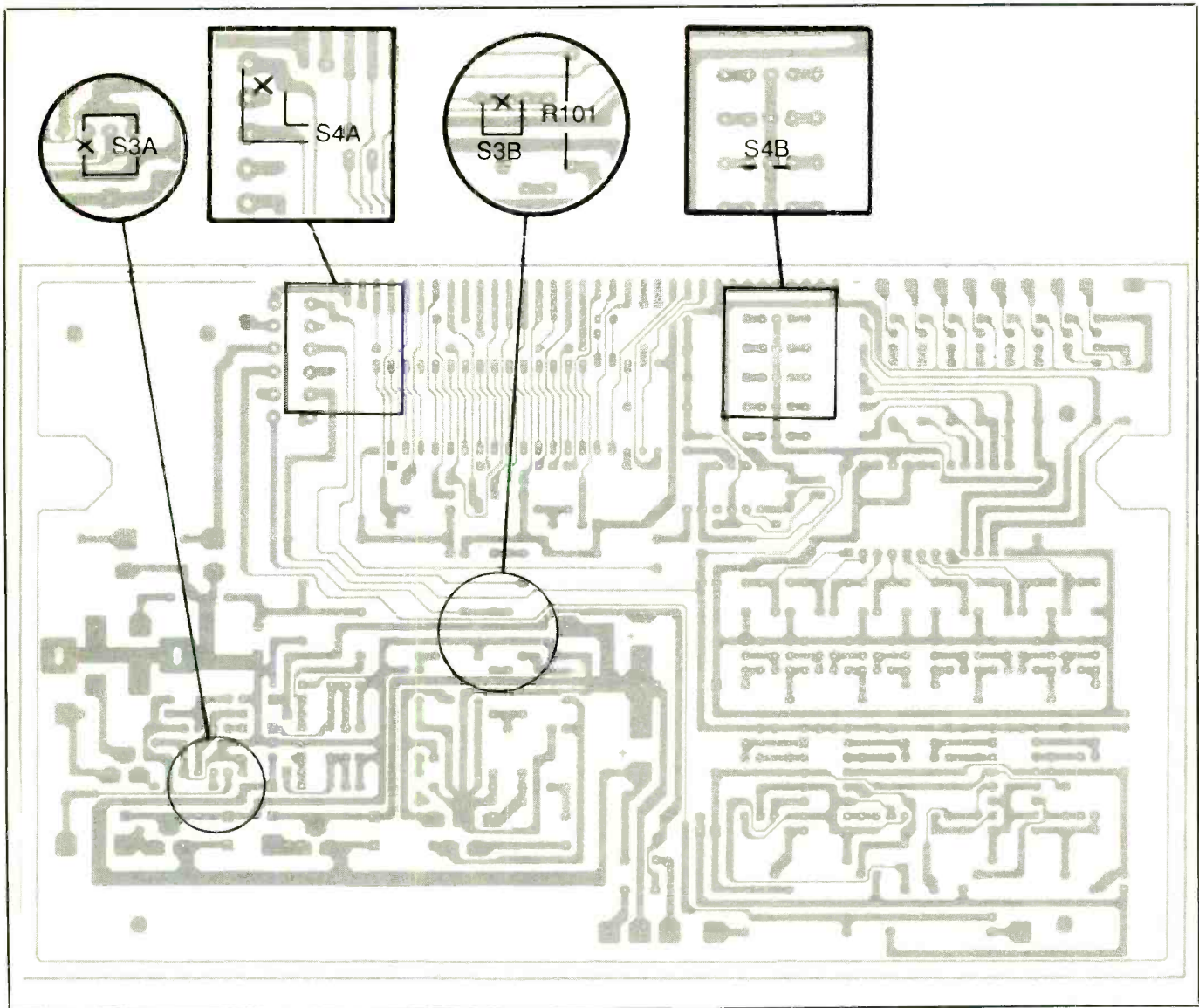

Fig. 2. Modifications for both signal tracer (circled) and signal injector (boxed) functions on main circuit-board assembly. Either or both modifications can be made, depending on your needs.

50 volts rms amplitude without damage. Even more importantly, the DMM's readout will display the dc voltage riding on the audio signal! Imagine being able to trace a distorted audio signal through an operational-amplifier circuit and noticing a dc voltage on an IC pin that should be at 0 volt. The range of the DMM is from -200 to +200 volts, with a resolution of 100 millivolts.

I modified my Semianalyzer while servicing a VCR with a servo problem. I needed to trace the control

pulse from the control head through the servo circuits, but my oscilloscope didn't have enough sensitivity to "read" the signal from the head. So I modified my Semianalyzer so that I could hear the control pulse and monitor the dc voltage at the same time. With my modified instrument, I discovered that I was able to find the leaky electrolytic capacitor that was causing the problem in just a few minutes.

In Fig. 1, you can see that dpdt switch *S3* has been added to the high-

voltage power supply of the original Semianalyzer circuit. One pole of the switch breaks the connection between *R5* and *IC5*, turning off the high-voltage supply. The second pole disconnects the supply from the amplifier circuit and test probes. There are two reasons why the supply must be disconnected in two places. One is that the first pole must shut off power to the inverter, which if left on for a long period of time would eventually overheat inverting transformer *T2*. The second reason

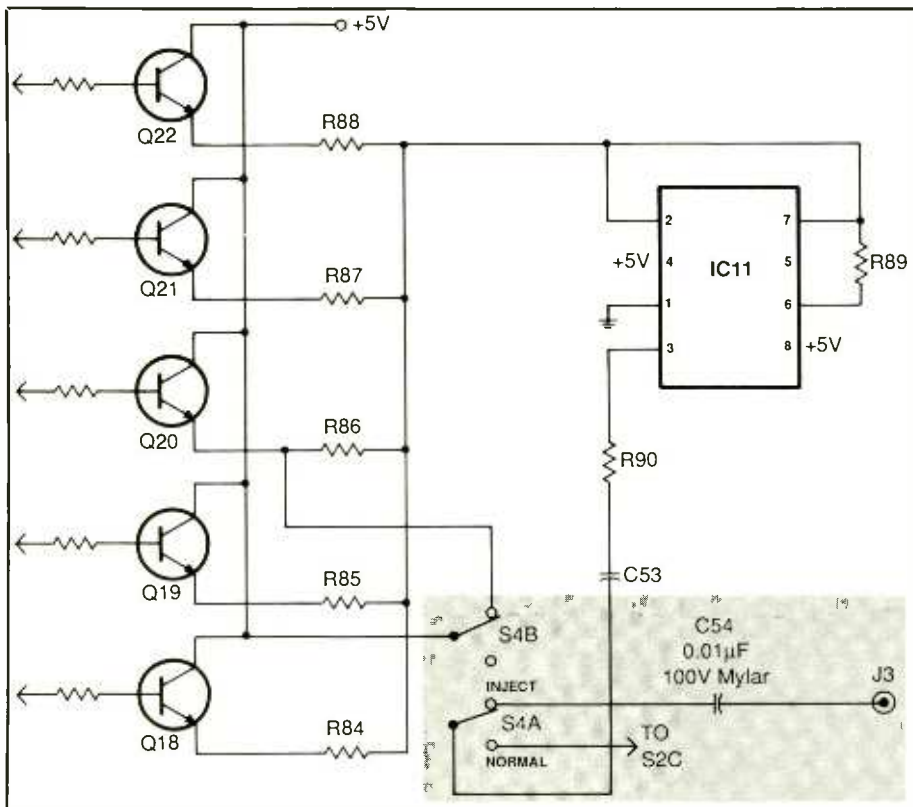

Fig. 3. Modifications for adding signal-injector function consist of adding dpdt switch *S4*, capacitor *C54* and jack *J3* to original Semianalyzer circuit.

is that the other pole eliminates loading down the circuit under test by components in the power supply.

Figure 2 shows the main circuit-board assembly's layout from the component side of the board. The modifications for the signal tracer are shown in circled details. (Modifications for the signal injector are shown boxed. We will get to these later.) To make the modifications, first locate *R5* (150 ohms) joining pin 3 of *IC5* to the base of *Q1*. Cut the conductor trace here as shown. Tack-solder hookup wires to the cut ends of the trace. Then run the wires to one pole of the new switch.

Now locate 10,000-ohm, 1-watt resistor *R8* and cut the indicated trace as shown. Tack-solder another pair of wires to the cut ends of the trace and run them to the other pole of the switch. Carefully drill a hole for the switch somewhere through the front or rear panel of the project's enclosure. Do *not* use a side

panel to mount the switch; if you do, the tilt handle will hit the switch.

In operation, when the TRACE switch is set to ON, the Semianalyzer performs normally. Setting the switch to OFF allows the Semianalyzer to be used as a signal tracer when the FUNCTION button is pushed to the BRKDN position. Input impedance of the tracer is the 15,000 ohms input impedance of the amplifier, so most circuits will not be affected by this load.

To complete modification, solder new 47-ohm, ½-watt, 10-percent tolerance resistor *R101* across lamp *II*. This lamp acts as an automatic level control (alc) to protect the speaker. However, it works so well that it would be difficult to compare a weak audio signal with a strong one. So installing *R101* across the lamp lessens alc action and increases the volume-level output of the speaker. The resistor will not affect normal operation of the Semianalyzer.

If you wish, you can remove the lamp from the circuit-board assembly and extend wires from its mounting holes to the position on the front panel where you can mount the lamp. Doing this, not only will the lamp act as an alc, it will also visually indicate audio levels.

Signal Injector

The Semianalyzer emits tones of different frequencies that inform you of circuit parameters. Tone oscillator *IC11* can be used to create the signal-injector function. Injector modification is completely independent of the tracer modification. Therefore, you can make either or both modifications according to your needs.

To supply the injector feature, install another dpdt switch (*S4* in Fig. 3) on the rear or front panel of your Semianalyzer. Wire the switch into the circuit as shown.

One pole of new switch *S4* joins the emitter and collector of *Q20* to turn on the oscillator; the other pole switches the output of *IC11* from the speaker to new red banana jack *J3* through new 0.01-microfarad, 100-volt Mylar capacitor *C54*. Figure 2 shows these modifications boxed.

To use the injector feature, be sure the FUNCTION push switch is in the JUNCT position and set *S4* to ON. At this point, a 400-Hz, 5-volt square wave will be available at *J3*. You must have a test lead plugged into the black banana jack on the Semianalyzer and connected to ground in the circuit under test to inject this signal into a circuit through another test probe connected to *J3*. **ME**

KIT AVAILABILITY

A complete Parts List for the Semianalyzer was published in the April issue. Individual components and complete kits for the Semianalyzer Model 59C are available from:

Electronic Design Specialists, Inc.
951 SW 82 Ave.
N. Lauderdale, FL 33068
(Tel.: 305-726-2427)

Learning From Failure

By Forrest M. Mims III

Have you ever become totally frustrated over the failure of a circuit to function as you expected? Those of us who have can certainly testify that more about a circuit can be learned when the circuit fails than when it functions flawlessly.

Advances in technology are often a by-product of technological failure. A classic example is the improvements made in the space shuttle's solid-propellant booster rockets that followed the *Challenger* disaster. The *Challenger* failure was but one of many that have plagued development of both solid- and liquid-fueled rockets. Consider, for example, the pioneering work done in liquid-fuel rockets by Dr. Robert H. Goddard during the first half of this century.

While Goddard's invention of the liquid-fueled rocket is known to many, less well known is his development of fully functioning inertial guidance systems, steerable rocket motors, parachute deployment systems and variable-thrust liquid-fuel rocket engines. These and many other developments were accompanied by frequent, sometimes discouraging failures. However, Goddard persevered through these failures because, as his wife Esther observed, they were "not really failures but lessons to learn, a scientist's way of learning." (Milton Lehman, *This High Man*, Farrar, Straus & Co., New York, 1963.)

Most of us who tinker with electronics have experienced various kinds of failures. Some are beyond our control, such as a defective component that proves difficult to identify. Others are consequences of our own mistakes, ineptitude or missed opportunities. I've learned much from all kinds of failures. Indeed, my career as an electronics writer has been directly influenced by the experiences gained from a dozen or so projects that failed to operate as planned or succeed as hoped.

On the other hand, however, occasionally I meet amateur and even professional electronics experimenters who have become quite discouraged by the failure or



Fig. 1. Lt. Forrest Mims prepares to launch a test rocket in Vietnam.

a circuit or project to operate as expected or hoped for. One talented experimenter and writer of electronics books became so discouraged by his lack of progress that he gave away all his electronics supplies and switched careers.

There is a better way: the Goddard approach. For this, my fiftieth "Electronics Notebook" in *Modern Electronics*, I will share several personal "failures" with you. Even though the projects to be described resulted in some degree of failure, each greatly expanded my technical knowledge.

Miniature Guided Rocket

Sometimes, the idea for a circuit or project germinates in the back of one's mind for months or even years before actual work is begun. Such was the case with the idea that occurred to me as a seventh grader. Instead of listening to the teacher, I was attempting to devise a method for controlling the flight of a small rocket without resorting to use of steering vanes or fins extending into the missile's slipstream. While staring at the point of a

pencil, it suddenly occurred to me that the flight of a rocket could be controlled by jetting from one of several ports around the side of the nose cone ram air that entered a hole in the cone's apex.

This idea percolated in my mind through high school and college. Within months after graduation, I built a series of small test rockets, one of which incorporated a primitive light-seeking guidance and control system based on the directed ram air concept. While serving in the U.S. Air Force, I continued this project during my off-duty time.

Figure 1 shows me preparing a radio-controlled test rocket for launch near Saigon, Vietnam in 1967. This rocket contained a single air outlet port that could be opened or closed by means of a radio signal. A small tape recorder was programmed to automatically transmit the radio signals after the rocket was launched.

The tape recorder sequence was actuated by a small switch the rocket rested on prior to launch. The objective of this test was to determine from smoke-trail photographs if course deflections were

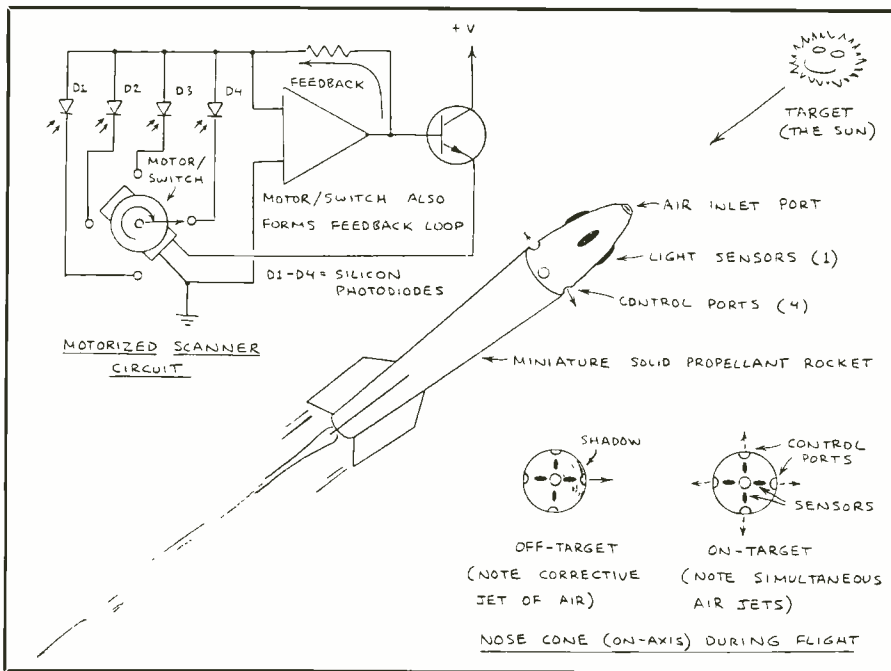

Fig. 2. A simple optical guided rocket.

produced when the air outlet was opened. Unfortunately, heavy cloud cover and an unplanned visit by a heavily armed helicopter precluded successful photography of this rocket, so I planned a series of night flights of rockets equipped with light flashers. This stage of the project came to a quick halt when security police mistook my first two launches for an enemy attack.

In 1969, Robert Lopina, then a professor at the Air Force Academy, and several of his students performed a battery of wind-tunnel and water-table studies that confirmed the principle of the ram-air control concept. I conducted dozens of launches of test rockets, photographing their smoke trails (day launches) or tracking lights (night launches) to measure the deflection caused by input and output ports of various dimensions.

While Bob and I prepared a paper on our results ("Ram Air as a Method of Rocket Control") for presentation at a conference of the American Institute of Aeronautics and Astronautics, I continued work on a fully functional light-seeking rocket that used the ram-air principle.

As shown in Fig. 2, four silicon sensors around the nose of this rocket detected the light from the target (the sun). So long as the detectors received equal illumination, air entering an inlet port was sequentially ejected from four ports around the base of the rocket's nose by

means of a motorized air deflector. However, if the rocket went off course, one or two of the detectors would receive less light than the others.

The motorized air deflector incorporated a rotating contact that swept across four quadrants of a circular piece of circuit board installed along the motor's axis. As each contact was selected by the wiper arm, one of the four detectors was connected to an internal amplifier. If the detector's signal level was below a preset threshold, power was removed from the motor and a signal was sent to an electric brake that almost instantly stopped the motor's rotation. The object was for the motor to remain stopped until air deflection brought the relevant detector back into the sun's light. The motor would then resume rotation.

This system worked fine on paper and, after weeks of painstaking work, on the workbench. Figure 3 shows the completed guidance and control package prior to installation in a rocket body. Above it is an earlier guidance and control package in which a single light detector was scanned by a turbine spun by ram air entering the nose of the rocket.

Finally, the time arrived to test the guidance and control package with a light source. I suspended the package from a line attached to a table so that the

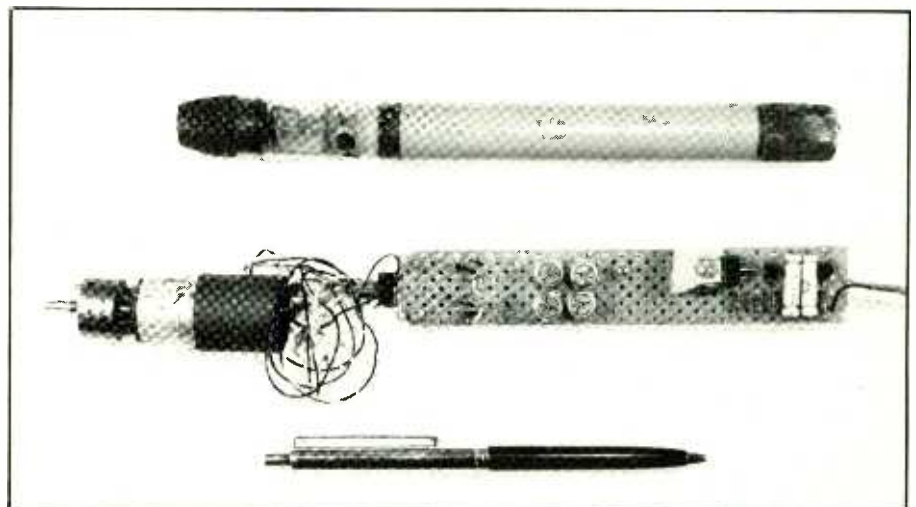

Fig. 3. Guidance and control package prior to installation in rocket body (center) and earlier guidance and control package (top).

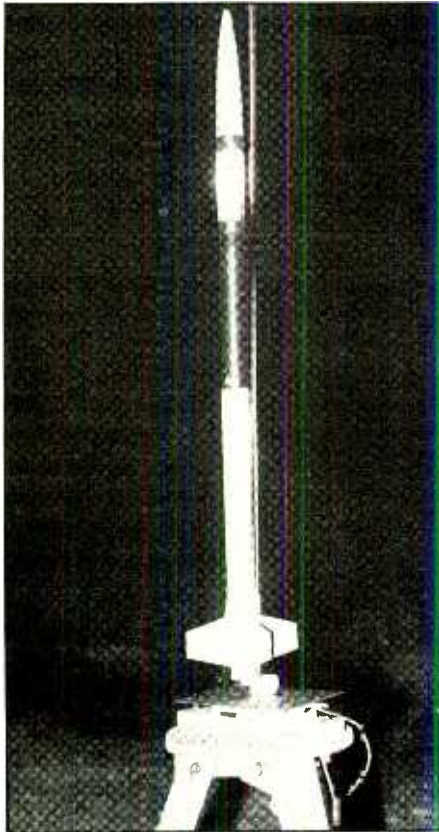

Fig. 4. Xenon rocket shortly before launch.

sensors looked directly at a light place on the floor. When power was applied, the motorized air deflector/scanner operated as expected. I then moved the light to one side, thereby reducing the amount of light falling on the detector on the opposite side of the guidance and control package. The system responded instantaneously. Power was removed from the motor and the brake locked the shaft.

Unfortunately, I had failed to consider a rudimentary principle of motion. As soon as the motor was stopped, the entire guidance and control package twisted and jerked. The inertia of the rotating mass of the motor and air deflector had been transferred to the guidance package. In an actual flight, this sudden stop in rotation would have caused the rocket to roll in flight. The guidance and control package into which many hours had been

invested was a failure.

Based on previous flight tests, I was convinced that the system would have worked had each of the four air outlets been controlled by an independent, non-rotating solenoid. However, a principal goal of this project had been to construct a guided rocket that used but a single servomechanism. So, I ceased efforts to build a flyable ram-air guided rocket.

So what was learned from this project? Even though a fully functioning guided rocket was not achieved, the principle of ram-air control was verified by extensive wind-tunnel and water-table tests and dozens of actual flight tests. The project resulted in a technical paper and several magazine articles.

This project also resulted in the formation of Micro Instrumentation and Telemetry Systems (MITS), Inc. MITS was formed in 1969 to make and sell the small transistorized tracking lights I used for photography and recovery of test rockets launched at night. In 1974, MITS developed the Altair 8800, the computer credited by many with pioneering the personal computer era.

Finally, the ram-air project caused me to switch careers. After writing a magazine article, my first, about the design and construction of the light flasher, I decided to leave the Air Force and become a full-time writer.

Xenon Strobe Rocket

Small incandescent lamps function well as tracking lights for rocket flights up to a thousand feet or so. For higher altitudes, however, a much brighter xenon strobe is preferable. Unfortunately, xenon strobe lights require a high-voltage power supply and are more complex than simple transistorized light flashers.

In 1974 I designed and built a small xenon strobe for a large model rocket. The strobe was assembled from components salvaged from a camera flash unit. It had a flash rate that was adjustable from 0.001 flash per second to 7 flashes per second. It was powered by a nickel-cadmium rechargeable battery. The complete system was installed in a payload

capsule that had a total length of 19 inches, including a 6-inch nose cone. Total weight of the strobe, all circuitry, battery and payload capsule was a reasonable light 5.5 ounces.

The xenon flashtube was installed inside a transparent section of the payload capsule. Therefore, its light was emitted from all sides of the rocket, as clearly shown in Fig. 4, a photo of the rocket taken a few minutes prior to launch. This photo was made by opening the camera's shutter until the strobe lamp fired. A flash unit mounted on the camera was then actuated and the camera's shutter was closed. The rocket's strobe is the bright section just below the nose cone.

The xenon strobe rocket was launched at 1:15 A.M. on August 10, 1974 atop a flat mesa just west of Albuquerque, NM. The rocket motor was an Enerjet E model with a machined graphite nozzle. The rocket reached an estimated altitude in excess of 1,200 feet.

The flight of this rocket was quite spectacular, the flashes from the xenon strobe being easily visible above the flame trail. As recorded in my notebook two days later, "The launch was the most graceful I have ever seen." The flame trail and flashes from the strobe showed up as spots of white on a photograph I exposed some 1,000 feet away from the launch site.

Between the fifth and sixth flashes, the rocket's motor burned out and the rocket coasted another three times the altitude achieved under the boost phase. Figure 5 is a drawing made by tracing a print of the flight photograph.

Unfortunately, the rocket motor's parachute ejection charge failed to function, and the rocket plunged toward Earth and impacted in soft sand a few hundred yards from the launch site. The next day, we returned to the launch site to find the remains of the rocket. As might be expected, the xenon strobe circuitry was totally destroyed by the impact of the crash. Figure 6 shows the remains of the payload section (A) and the electronics and what was left of the electronics (B). The xenon flashtube was pulverized by the crash and is not shown in (B).

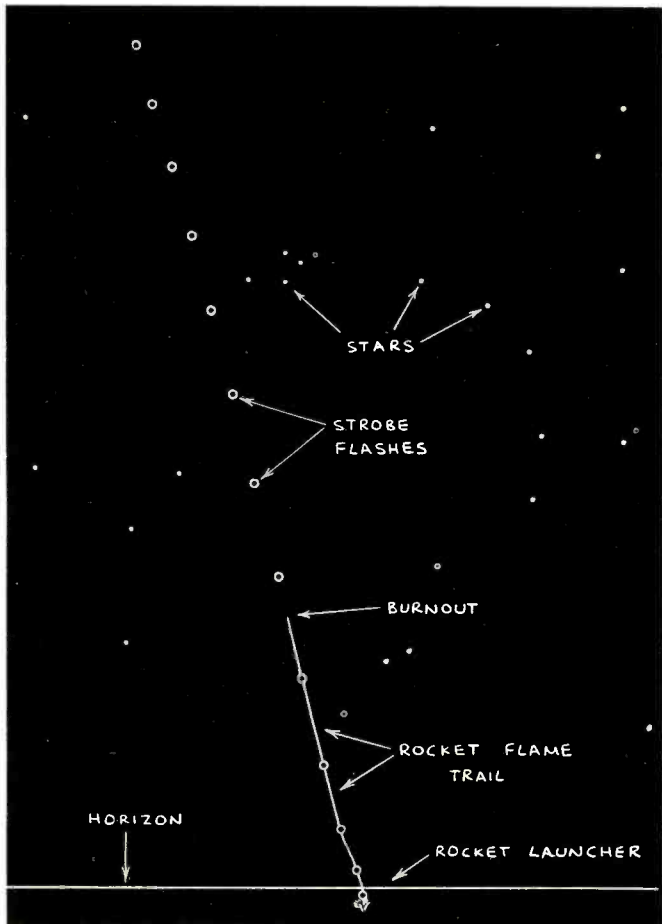
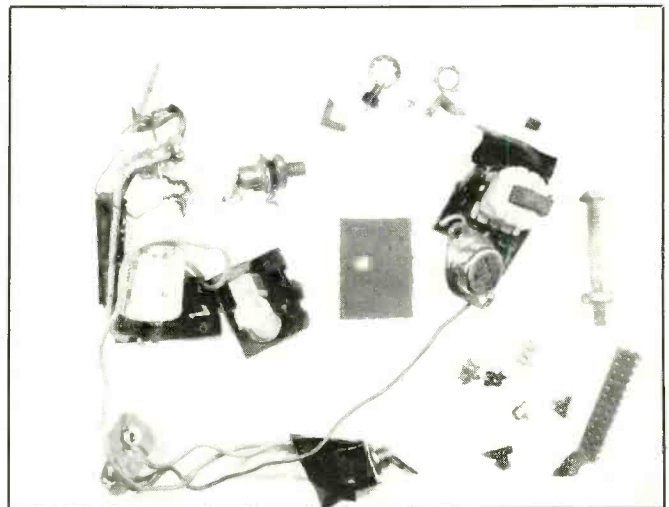

Fig. 5. Flight test of night-launched strobe-equipped rocket.

Fig. 6. Photos show (A) remains of crashed payload section of xenon strobe rocket and (B) demolished electronic components of same.



(A)



(B)

Incidentally, the battery that powered the strobe circuit was undamaged. It had been surrounded by a soft layer of foam plastic. For many years, this battery powered a miniature flashing strobe light I took on bicycle trips.

While the flight of this rocket ended in failure, the flight itself was completely successful. The flight proved that a xenon strobe light could be miniaturized and flown in a high-altitude model rocket. It also demonstrated that the flashes were bright enough to be recorded on film 0.2 mile from the launcher.

Though I have not since launched a xe-

non strobe light in a rocket, the knowledge and experience gained from this project enabled me to construct a series of miniature xenon strobes for use as bicycle warning lights and for description in magazine articles. In short, the brief and spectacular rocket flight was well worth the time invested in building that miniaturized xenon strobe.

Travel Aid for the Blind

Since 1966, I have developed a variety of miniaturized travel aids for use by the blind. All are near-infrared active radiat-

ing devices. In other words, they are equipped with a near-infrared-emitting source whose beam is projected outward in a narrow beam. An object that is illuminated by the beam scatters some of the oncoming infrared back toward the receiver, where a photodiode detects the returning signal and passes it on to a high-gain amplifier. If the signal exceeds a preset level, the blind user is informed about the presence of an object by an audible or tactile signal.

These simple travel aids can detect from a distance of 10 feet or more objects that intercept most of the beam. Actual

detection range is determined by the near-infrared reflectance of the object and the area of the object illuminated by the beam.

While the basic design concepts of an infrared travel aid are relatively straightforward, development of a practical aid involves considerable testing and many design tradeoffs. Some of the key design tradeoffs include:

(1) *Radiant Energy.* Both near-infrared and ultrasonics have been used in various travel aids for the blind. Ultrasonics provide a simple means for range finding since the speed of sound is so much slower than that of light. Therefore, most travel aids have used the ultrasonic approach. Near-infrared, on the other hand, has the advantage of being very small in terms of optical sources and sensors. Furthermore, the reflectance properties of most materials are better suited to near-infrared than they are to ultrasonics. A surface that is smooth with respect to the wavelength of incident energy is a *specular* reflector that will reflect an oncoming beam at the angle of incidence rather than diffusely. Thus, a glass window is a specular reflector at both near-infrared and ultrasonic wavelengths. Only if the beam is aimed perpendicular to the surface will it be reflected back toward the travel aid. Otherwise, the transmitted beam will be reflected away at an angle and not be diffusely scattered back toward the travel aid.

Since ultrasonic wavelengths are considerably longer than those in the near-infrared range, file cabinets and the like appear as specular reflectors to an ultrasonic beam. Therefore, near-infrared is a better choice when a broad variety of objects must be detected. It's long been my choice, though I have experimented with a commercial ultrasonic travel aid.

(2) *Infrared Source.* The source should be capable of generating brief pulses that have fast rise and fall times. Both LEDs and laser diodes are suitable choices. LEDs are inexpensive, but their broad emission angle permits only 10 to 30 percent of the near-infrared energy they emit to be collected by a lens for collimation into a beam. Laser diodes cost more, but



Fig. 7 Author's eyeglass-mounted infrared travel aid for the blind.

their relatively narrow beam means nearly 100 percent of the infrared energy they emit can be collected. Though I have experimented with various kinds of laser diodes, all the test aids I've built use AlGaAs near-IR-emitting diodes.

(3) *Audible vs. Tactile Stimulation.* It's easy to inform a travel-aid user about the presence of objects by means of an audible tone, which can be directed directly into the ear via a small acoustic tube or directly from the aid itself. In the latter case, nearby people will also hear the tone. In any event, in my experience, most blind people would prefer not to have a tube or small receiver in their ear. That's because they depend on their hearing to detect sounds so subtle that are often ignored by sighted people. Therefore, various kinds of piezoelectric or electromagnetic vibrators are often used to provide a tactile signal. Though all the aids I have tested with blind people have used audible stimulation, I've investigated piezoelectric and electromagnetic tactile stimulators and will probably incorporate a tactile output device into a future travel aid.

There are many more aspects to the design of travel aids for the blind, so many a book would be needed to cover them all. Suffice it to say that today's technology easily permits assembly of a complete travel aid into eyeglass frames. Indeed, this is the approach I took in 1972 when I installed several travel aids on eyeglass frames and tested them with blind subjects. One such travel aid is shown in Fig. 7.

In recent years, I've designed an aid that is far superior than the one shown in Fig. 7 and hope to someday make some prototypes. Why haven't I done so already? Travel aids for the blind and prosthetic devices in general are highly specialized. Not all blind people wish to use an electronic travel aid and those that do have many different requirements. Companies hesitate to make such products for such an indefinite market. Then there's the liability problem. If a blind person is injured while using a travel aid, the maker might face a liability suit.

In short, though I've worked with travel aids for the blind for more than 22 years, I've yet to develop a viable commercial product. In that respect, the project has been a failure. On the other hand, most of what I know about solid-state electronics and especially optoelectronics and surface-mount technology originated in this work.

Many magazine articles and at least five books were a direct outgrowth of my travel-aid project, and I have very much enjoyed working with the blind children and adults who've tested my devices. Someday, I hope to develop a practical near-infrared travel aid. Whether or not that effort is successful, I am confident much will be learned.

Summing Up

In this column, I could have listed many more of the dozens of "failures" that form the foundation of my technical knowledge. For example, there was the capacitor-discharge rocket-guidance project (the rocket flew but the discharging capacitor had no impact on its flight) and the one-mile laser communicator that worked over a thousand feet. Most recently, a radio-controlled camera suspended from a parafoil kite fell some 70 feet to the ground when the line between the camera and kite failed.

In short, I hope this account of the positive side of "failure" offers encouragement in designing a circuit or finding a problem in an existing circuit. As Dr. Goddard might have said, technical failures are the road signs to success. **ME**

Switched-Capacitor Filter ICs & LED Replacements for Incandescent Lamps

By Harry L. Helms

Switched-capacitor filter ICs can be thought of as "active filters on a chip," combining all the circuitry needed for various active-filter functions in a single IC package. Micro Linear recently introduced two such devices, the ML2110 universal dual filter and the ML2111 universal high-frequency dual filter. Each contains two independent switched-capacitor filters that perform low-, high- and band-pass functions, as well as notch filtering. Each can be configured as Bessel, Butterworth, Cauer and Chebyshev filters. Center frequencies are tuned by an external clock, which can be a TTL or MOS source. The ML2110 and ML2111 are essentially identical except for frequency range, as the ML2110 can be operated to 30 kHz, while the ML2111 can operate to 150 kHz. Pin connections for both are the same and are shown in Fig. 1. An internal block diagram for both devices is shown in Fig. 2.

In Fig. 1, pin 7 is the positive analog supply input, while pin 8 is the positive digital supply. Pin 13 is the negative digital supply, while pin 13 is the negative analog supply. Pin 15 is an analog ground pin. Clock input for filter A is at pin 10, and the clock input for filter B is pin 11. Pin 9 (LSh) sets a threshold for logic levels of the clock inputs of 1.4 volts above the voltage applied at this pin.

Pin 12 is the input pin to select the clock center-frequency ratio of either 50:1 or 100:1 or to hold the last sample of the bandpass or low-pass outputs. The 50:1 ratio is selected by holding pin 12 to a high logic level (either the analog or digital positive supply voltage), while the 100:1 ratio is selected by holding pin 12 to the same level as pin 15 (the analog ground).

Each filter section has an input (pins 4 and 17) that is applied to an inverting amplifier (as shown in Fig. 2). The outputs of the inverting amplifiers can be taken as the output of a notch, high-pass, or "all-pass" (that is, no filtering action) filter at pins 3 and 18 or applied as an input to summing amplifiers (identified in

Fig. 2 by the sigma symbol). Additional inputs to the summing amplifiers can come through feedback from the output of two cascaded amplifier sections, from auxiliary signal inputs at pins 5 and 16, or the input of the summing amplifier can be connected to analog ground. Pin 6 ties the negative input of the summing amplifiers to the low-pass outputs when it is high and switches it to ground when connected to the negative supply voltage. Bandpass filter outputs are at pins 2 and 19, while the low-pass filter outputs are at pins 1 and 20.

The ML2110 and ML2111 can be configured in a variety of ways. Figure 3 shows the ML2110 with both filter sections cascaded to produce a fourth-order Chebyshev bandpass filter. The center frequency is clock tunable. For example, a clock frequency of 40 kHz would give a

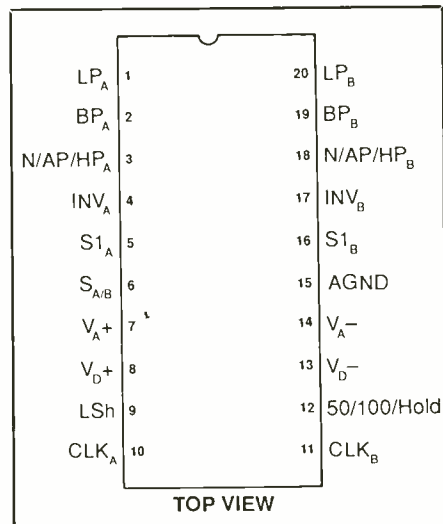

Fig. 1. Pinouts for Micro Linear's ML2110/ML2111 switched-capacitor filter ICs.

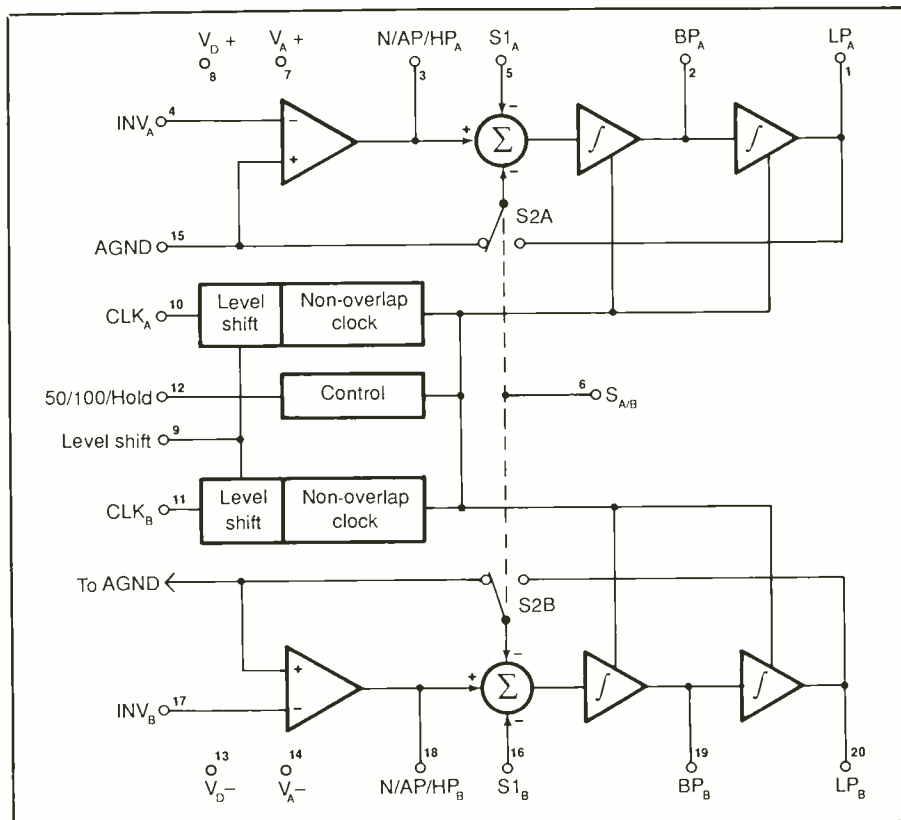

Fig. 2. Block diagram of internal circuitry of ML2110/ML2111 filter ICs.

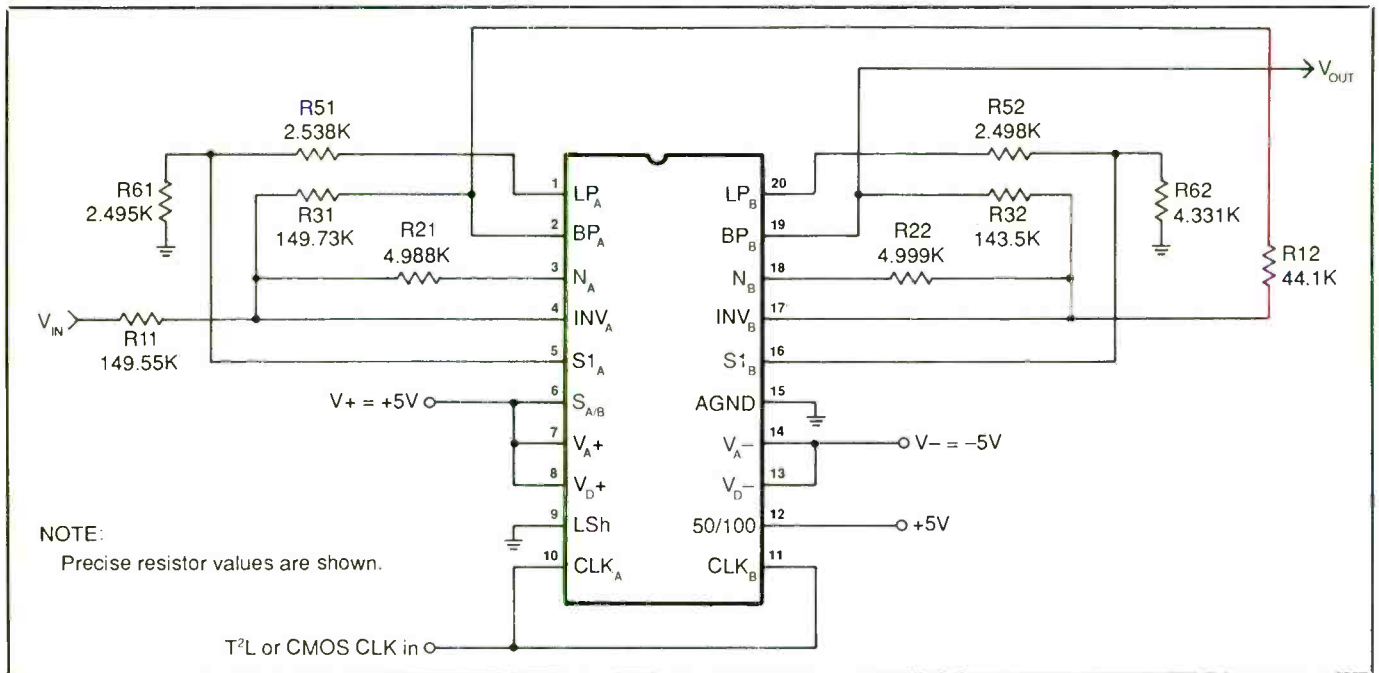

Fig. 3. Both sections of ML2110 cascaded to produce fourth-order Chebyshev bandpass filter.

center frequency of 1 kHz, while a clock frequency of 800 kHz would produce a center frequency of 20 kHz. Rejection of frequencies more than 10% from the center frequency is more than -25 dB.

Figure 4 shows a low-pass filter constructed using the ML2111. The output of this circuit is fairly flat for input signal frequencies up to 100 kHz, beyond which point any input is sharply attenuated. Attenuation ranges from approximately 20 dB at 200 kHz to more than 60 dB at 500 kHz. Both filter sections of the ML2111 are cascaded to produce the low-pass functions.

Figure 5 illustrates a notch filter using the ML2110. A clock frequency of 1 MHz will produce a rejection notch that exceeds 50 dB centered on 1 kHz. Input signal frequencies of up to 800 Hz and greater than 1.2 kHz will pass through the filter without attenuation. Signals at 900 Hz and 1.1 kHz will be down approximately 15 dB, with attenuation increasing all the more rapidly as 1 kHz is approached. Since the notch filter is pro-

ML2110/ML2111 Specifications	
Supply voltage (maximum)	13 volts
Supply voltage range	±2.25 to ±6 volts
Input voltage	Should not exceed analog/digital supply levels
Clock frequency	
ML2110	2.5 kHz minimum, 1.5 MHz maximum
ML2111	2.5 kHz minimum, 7.5 MHz maximum
Center frequency (maximum)	
ML2110	30 kHz
ML2111	150 kHz
Power dissipation	750 mW

duced by combining two separate filter sections, the attenuation actually *decreases* at precisely 1 kHz, from about 53 dB to approximately 47 dB. However, this is usually not significant in the majority of applications.

Additional information and applications circuits can be found in the "ML2110 Universal Dual Filter" and "ML2111 Universal hi-Frequency Dual

Filter" data sheets available from Micro Linear, 2092 Concourse Dr., San Jose, CA 95131. You should request these data sheets on your company or professional letterhead.

LED Replacements for Incandescent Lamps

Light-emitting diodes have long been

SOLID-STATE DEVICES...

touted as being eventual replacements for many incandescent lamps. Data Display Products recently introduced its MX401 series of LED bipolar incandescent lamp replacements, which show real progress toward workable LED substitutes for incandescents. A photo of the MX401 series is pictured in Fig. 6.

The MX401 series has a built-in full-wave bridge rectifier and can operate from a dc supply of either polarity or under ac conditions. Maximum voltage varies among members of the MX401 family and ranges from 24 to 130 volts with built-in current-limiting resistors. The nickel-plated base is available in miniature bayonet, screw, or flange packages. A six-chip LED and Fresnel lens (clear or tinted) are used, and red, green, and amber colors are available. Operating current ranges from 20 to 60 milliamperes. The MX401 series can directly replace the 239, 755, 1819, 1829 and 1892 incandescent lamps.

Compared to incandescent lamps, the MX401 series can operate at lower voltages, has a longer lifetime, is more resistant to vibration and shock, has a much

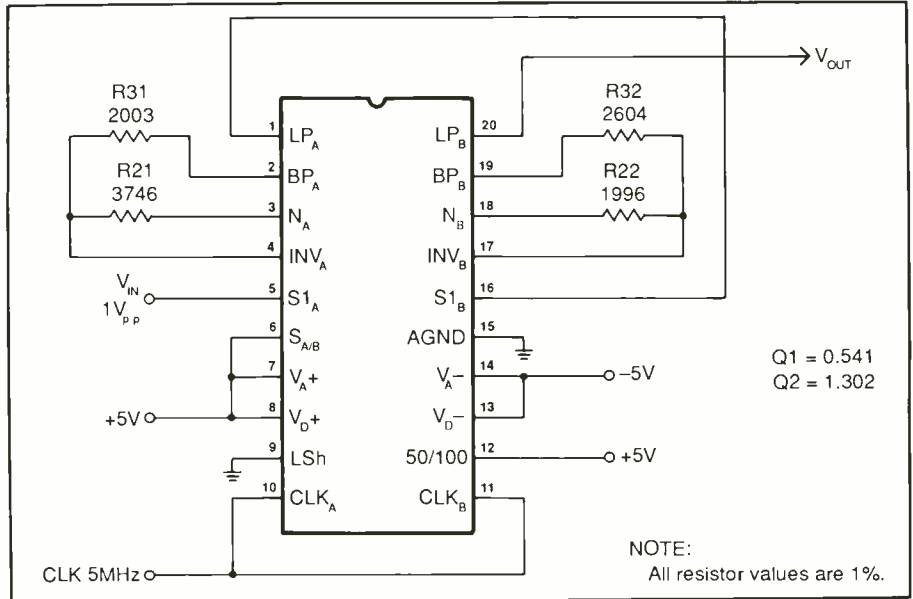

Fig. 4. A low-pass filter circuit designed around the ML2111.

faster on/off time, and usually does not fail catastrophically (instead, the light output will decrease over a period of time). More information can be found in the Data Display Products catalog avail-

able from P.O. Box 91072, Los Angeles, CA 90009.

Short Takes

Cherry Semiconductors has announced

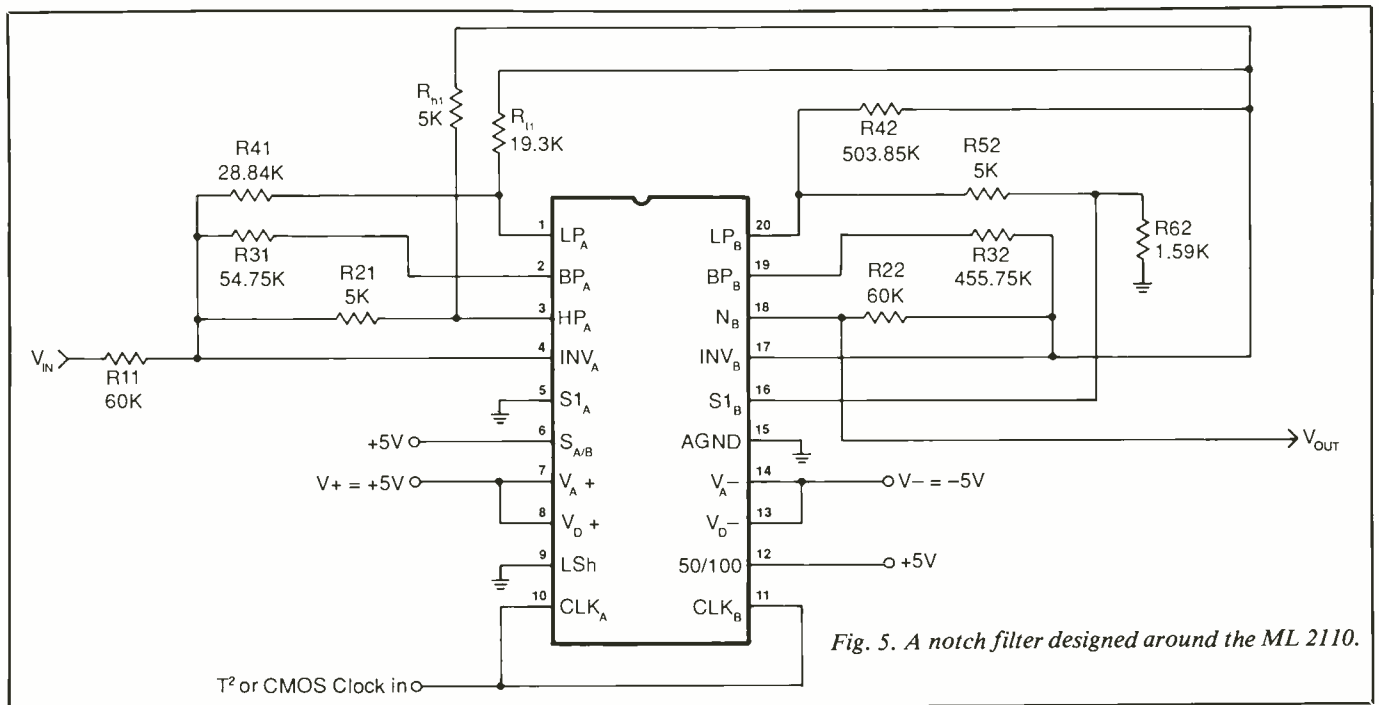

Fig. 5. A notch filter designed around the ML2110.



Fig. 6. Data Display Products' new MX401 series of LED bipolar devices designed to replace incandescent lamps come in various base configurations.

the CS-320 and CS-321 current-mode control devices for power-supply regulation and motor-control applications. Both are capable of switching at rates up

to 1 MHz and have been designed for interfacing with current-sensing MOS-FETs. Complete data sheets are available from Cherry at 2000 S. Country Trail, E. Greenwich, RI 02818 . . . New from GE Solid State is application note ICAN08756, "A Comparative Description of the UART—Universal Asynchronous Receiver/Transmitter." It describes the architecture and functions of various types of UARTs and gives tips on selecting the best UART for a particular application. It's available from GE Solid State, Box 3200, Somerville, NJ 08876 . . . Software support for the 88000 RISC (reduced instruction set computing) processor described in the July edition of this column is growing at a rapid rate. Compilers for Ada, BASIC, C, and Fortran have been announced, along with emulators to allow MS-DOS applications to run directly on the 88000. Who will be the first to announce a microcomputer using the 88000? **ME**

"Made in U.S.A."



Since 1965

We've been supplying quality crystals since 1965 — long before the flood of cheap imports.

We're still supplying quality crystals with

- Quick Turnaround
- Low Price
- High Quality

TO SOLVE CRYSTAL PROBLEMS, GET THIS CATALOG

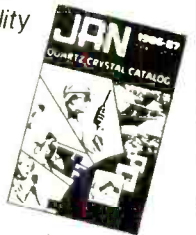

JAN CRYSTALS
P.O. Box 06017
Ft. Myers, FL 33906
(813) 936-2397



CALL 1-800-237-3063
FREE (Except Florida)

CIRCLE 19 ON FREE INFORMATION CARD

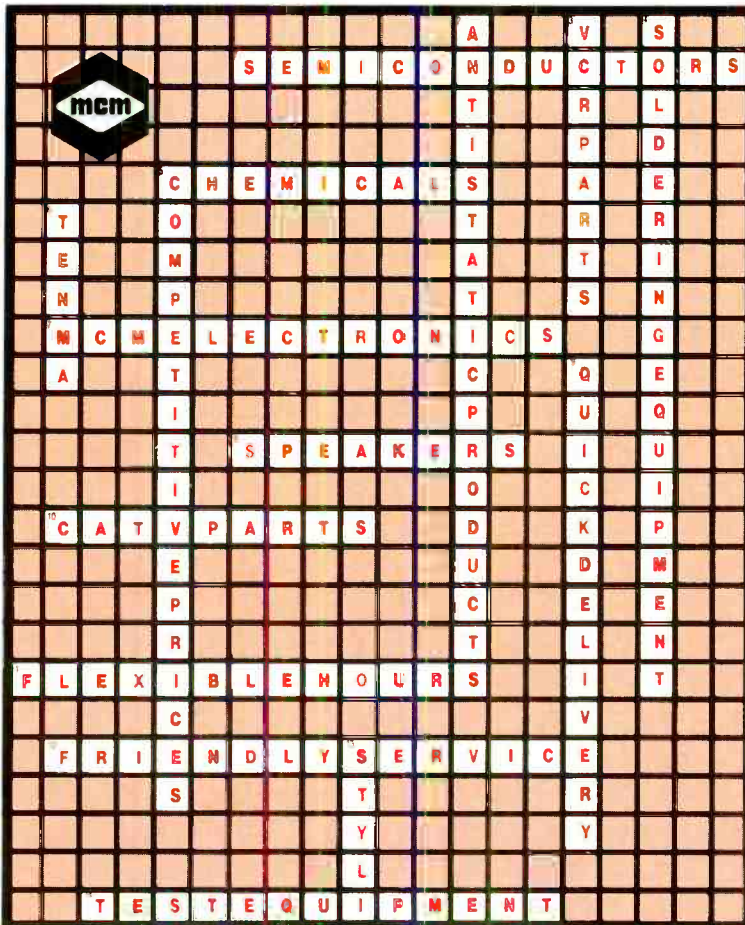

The answers to all those puzzling questions on electronic parts — are at MCM Electronics!

ACROSS

1. Diodes, transistors and ICs
2. Cleaners, lubricants and more
3. Your source for quality electronic parts!
4. EV, Pyle, Pioneer

5. Cable TV accessories
6. 7 a.m. to 8 p.m. Mon-Fri. and 9 a.m. to 5 p.m. Saturday (EST)
7. Knowledgeable sales people
8. Tenma, B&K, Leader, Hameg

DOWN

1. ESD protection
2. Video Cassette Recorder sub-assemblies
3. Technician tools for making connections
4. Another reason to buy from MCM!
5. High quality test equipment at competitive prices
6. 90% of all orders shipped in 24 hours
7. High fidelity needles



CALL TOLL FREE 1-800-543-4330
IN ALASKA AND HAWAII, 1-800-858-1849
IN OHIO, 1-800-762-4315



MCM ELECTRONICS
858 E. CONGRESS PARK DR.
CENTERVILLE, OH 45459-4072
A PREMIER Company

SOURCE NO. ME-41

CIRCLE NO. 158 ON FREE INFORMATION CARD

Electronics-Oriented BBS's

By Curt Phillips

Since running a computer bulletin board (BBS) requires a substantial investment of time and money in computer and electronic equipment, it is not surprising that many of them are oriented toward ham, SWL and other electronics topics.

In addition to my own growing listing of ham and electronics BBS's, I recently downloaded a compilation by Tom Brown KA2UGQ. The combined listing appears in Table I. Remember, due to possible changes or typographical errors, don't call these numbers late at night until you have verified that they are still BBS's operating as computer bulletin boards.

These bulletin boards are excellent places to exchange messages with fellow hobbyists, and most are well stocked with free or shareware programs of interest to electronics enthusiasts.

The most prevalent programs are packet terminal programs and programs to calculate beam headings to various countries from your latitude and longitude. There are also quite a few programs available to perform elementary electronics calculations such as Ohm's law, feed-line impedance and dipole antenna lengths.

Some of the more sophisticated programs can provide substantial help in designing bandpass filters, notch filters, op-amp circuits, oscillators and other electronic circuitry. Also available are programs to locate satellites and design multi-element quad and Yagi antennas. Programs to calculate maximum usable frequency (MUF) are growing in number and popularity, as are "gray-line" calculators and DX locators.

Although some of the of the programs are compiled, quite a few require a BASIC-language interpreter. The majority of programs are for PC compatibles. But many programs are also available for the Commodore 64 computer.

Morse Code

If learning the Morse code has been a stumbling block preventing you from obtaining your ham license, you can get help from any one of several Morse code

training and practice programs available on these BBS's.

By the way, in Canada, where they have a no-code digital-class license, they are now getting complaints that the theory portion of the test is too difficult.

For anyone truly interested in operating on the ham bands, learning the code is not an overwhelming obstacle. The programs on these BBS's can provide an endless supply of random code practice, allowing you to avoid W1AW's jammers and the memorization that can occur with some tapes.

I encourage you to take advantage of all the training aids available today to gain proficiency in the code and join us on the ham bands.

PC Pursuit

I hope that last month's discussion of the NOAA BBS and the listing of electronics-oriented BBS's this month will have you firing up your modem often. If you are calling long-distance BBS's regularly, you may have noticed your phone bills rising a little too high for comfort. If you're averaging two to three hours per month calling long distance for modem connections, Telenet has a service you need to know about: PC Pursuit.

Telenet has a nationwide multiplex packet-switching network set up primarily for business computer traffic being carried during workdays. To generate revenue and activity during the evening

Table I. Electronic/Ham/SWL BBS's

Phone Number	Name	Sysop	Location	Baud
201-271-4517	WB2TIX Radio BBS	WB2TIX	Bound Brook, NJ	3
201-494-3649	Micro-Fone TBBS	K2SHY	Metuchen, NJ	3BC
201-694-8122	Sonnet	Jim Sonnet	Mountain View, NJ	3BC
201-757-1491	Holly Park PBBS	Dick Roberts	Piscataway, NJ	3BC
201-943-7759	N2DSY CBBS	N2DSY	Little Falls, NJ	N/A
203-237-1717	Summa Zulla Znode 43	KA1TB	Meriden, CT	3B
206-285-3040	Ham-Net/Elect. BBS	P.Kitsfelds@WB7EWO	Seattle, WA	3
212-250-7090	Packeteers of NY BBS	KB2CQ	New York, NY	3BC
213-376-6221	Beach City	KB6MND	N/A	3B
213-377-0450	Amateur World	N/A	N/A	3B
213-541-2503	WB6YMH (GFRN) RCP/M	WB6YMH	Palos Verdes, CA	3BC
214-223-0983	N/A	Mark Collard	Dallas, TX	3B
214-340-5850	Satellite/FAX BBS	N51TU	N/A	3B
214-960-2730	NN5I BBS	NN5I	N/A	3B
215-628-9265	K4KWW BBS	K4KWW	PA	N/A
215-827-7689	K3DSM BBS	K3DSM	Malvern, PA	N/A
215-948-0593	N/A	K3DSM	PA	N/A
217-368-3124	ANARC	ANARC	N/A	3
218-525-1788	N/A	Ron Carlson	Duluth, MN	3B
301-344-9156	NASA Goddard BBS	NASA	Greenbelt, MD	N/A
301-350-1299	Mad Faces BBS	Kim Wells	Upper Marlboro, MD	3B
301-540-1378	WB6RQN Usenet gateway	WB6RQN	Germantown, MD	N/A
301-540-9095	WB6RQN Usenet gateway	WB6RQN	Germantown, MD	N/A
301-655-0395	WA3MEZ BBS (Ringback)	WA3MEZ	Randallstown, MD	N/A
301-926-8187	3 Winks	W3INK	Gaithersburg, MD	3B
303-273-4136	N/A	Emmett Earley	Ravenswood, WV	3
303-497-6968	Boulder Fido	N/A	Boulder, CO	N/A
303-593-0766	HIP Shack Fido BBS	N3EUA	Colorado Springs, CO	3BC
303-781-1079	Photo Tech	N/A	N/A	3B
305-859-9443	Orlando Communicator	WA4GIF	Orlando, FL	3B
312-925-0259	Chicago Forum-80	N/A	Chicago, IL	N/A
312-674-1638	Bill's Ham	N/A	Chicago, IL	3B
313-629-2854	Flint Area BBS	KA8OCN	Flint, MI	3
313-759-6569	Royal Oak RCP/M	W8SDZ	Royal Oak, MI	3B
318-688-7078	NoChange #2	Mike Berry	Shreveport, LA	3
404-289-2050	NoFrills BBS	WB4LBM	Decatur, GA	3
404-363-1640	Hams Bulletin Board	WA4CBT	Forest Park, GA	3B
404-378-7914	Shareware South	Steve Rohrer KA4RSZ	Decatur, GA	3B
404-393-3083	Atlanta Radio Club	N/A	Atlanta, GA	3B

hours when the system is less used by businesses, Telenet has established PC Pursuit.

For a flat fee of \$25 per month, PC Pursuit lets you establish an unlimited number of long-distance connections on Telenet's data network between 6:00 P.M. and 7:00 A.M. from Monday through Thursday and from 6:00 P.M. Friday to 7:00 A.M. Monday. Usage during workdays is billed at a per-hour rate.

Telenet's data network (and, thus, PC Pursuit) can be accessed from nearly 18,000 local telephone exchanges, but you can only call to exchanges in 25 cities. These cities (see Table II) aren't necessarily the largest, but those with an abundance of business-data activity.

Most operation on PC Pursuit is at 1,200 bits/second, although there is limited support for 300 and 2,400 bps.

The mechanics of packet-switching are similar to those in packet radio, which can mean that throughput speed is sacrificed in order to share bandwidth with a multitude of users. When you're entering text, you'll usually notice a slight delay between the time you type a character and its appearance via echo on your video display monitor.

The overhead of error-detection information compounds this problem when transferring binary files. Error-correction protocols like XMODEM and YMODEM send blocks of data followed by a checksum or other error-detection

data, and then wait until the other computer signals that it has received the data correctly before sending the next block. Since both the block of data and the acknowledgment signal are delayed by the packet-switching network, the efficiency of file transfers can drop significantly. Effective throughput of approximately 50 percent (1,200 bps becomes equivalent to 600 bps) is common with XMODEM, while YMODEM averages about 70 percent, and some of the newer protocols (where available) can approach 90 percent in file-transfer efficiency.

When calling in to PC Pursuit, your computer should be set to 7 data bits, even parity and 1 stop bit (7E1). After logging on, you have to enter a command to connect you to the area of your choice. Script files to automatically send and repeat this information are available on BBS's for most common terminal programs; these are almost a necessity. Most of the dial-out nodes are often busy, so having to constantly retype the command sequence gets quite aggravating.

Once connected into the area of your choice, you can use the autodialing feature of your terminal program; the Telenet modems recognize Hayes-type commands and respond to them almost transparently. Since most file-transfer protocols require 8N1 configuration, you should have your terminal program reset to these parameters once connected.

Despite the limitations, the hundreds of BBS's in the 25 dial-out nodes make PC Pursuit an excellent value. There is a \$25 registration fee, and you must have a Visa or MasterCard for the monthly charges. To register or get more information on PC Pursuit, call 1-800-835-3638 (voice) or 703-689-5700 (voice).

For the most up-to-date listing of PC Pursuit access numbers, call 1-800-424-9494 by modem (7E1). After connecting, type three carriage returns (enters), and then input your area code and local exchange. At the "@" prompt, type "MAIL." For the user name, type "PHONES." Also use "PHONES" as the password.

More information on PC Pursuit is also available via modem from the Online BBS at 1-800-835-3001 and the Net Exchange BBS at 703-689-3561.

Phone Number	Name	Sysop	Location	Baud
404-476-7970	Ham Board One	N/A	N/A	3B
404-493-4708	Randy's BBS	N/A	N/A	3B
404-949-0687	Lockheed Amateur BBS	N/A	N/A	3B
415-961-7250	BBS-JC	N/A	N/A	3B
415-858-0363	Packet UNIX BBS	login: packet, password: net	N/A	N/A
416-231-0669	Humber Queensway BBS	VE3OOZ	Toronto, Canada	3B
416-598-1934	Boards Galore	N/A	N/A	N/A
504-834-2544	The Connection	Keith LaBorde	New Orleans, LA	3
509-697-7298	Cent. Washington BBS	K7FTV	Selah, WA	3B
516-472-0691	The Idea X-Change	N2AYB	Bayport, NY	3B
516-736-2208	Bald Hill Tech. Cont.	W2JUP	Farmingville, NY	3
603-424-5497	Stateline BBS	Bob Wescott	Merrimack, NH	3B
609-268-9597	Morningstar Keep	KA2BQE	Indian Mills, NJ	3BC
609-859-1910	Pineland RBBS (SCDX)	SCDX	Vincentown, NJ	3B
612-291-0567	Digital Newsletter	K0TG	St. Paul, MN	3B
612-431-1149	HR Commodore Clique	WA0CQC	Apple Valley, MN	3
614-866-4392	UBIX	N/A	N/A	N/A
617-565-9136	WB3ABN BBS	WB3ABN	Boston, MA	3B
701-746-4814	Shortware Network	N/A	N/A	N/A
703-250-1837	SMA	N/A	N/A	N/A
703-435-0836	Sterling Info. Exch.	KF4GL	VA	3
703-734-1387	AMRAD BBS	AMRAD	Fairfax, VA	3B
718-761-5727	Shortwave BBS	David Snyder	Staten Island, NY	N/A
804-851-0030	Old Dominion	N/A	N/A	N/A
805-251-5558	Westlink Report BBS	(entry:WLR)	Canyon Country, CA	N/A
813-874-3078	Pac-Comm, Inc. BBS	KC2FF/W1BEL	Tampa, FL	3BC
818-967-3108	Dataline	N6ECN	N/A	3B
904-733-4515	Jace	N/A	N/A	N/A
907-243-0324	N/A	Dick Phillips	Anchorage, AK	3
914-359-0180	Mnematics Videotext	WA2IAC/(K2SK-HR SIG)	Sparkill, NY	N/A
914-485-3393	Hamnet-80	Bob Farrell	Poughkeepsie, NY	3B
914-677-1288	ACE	N/A	NY	N/A
Others:				
(353) 1-88-56-34	Dublin Users BBS	N/A	Dublin Ireland	3BC

Baud Rates: 1 = 110; 3 = 300; B = 1,200 (Bell 212A); C = 2,400 (CCITT V.22 bis).

Book Beat

Although this is not where books are usually reviewed, I have a special reason for mentioning two books in this space.

Computing Across America by Steven K. Roberts would not be the type of book to be reviewed in *Modern Electronics* except for the way it's being marketed.

At several hamfests and at Comdex/Atlanta, I have been seeing a tall, bearded fellow with a recumbent bicycle loaded with electronics, computers and ham gear promoting his book, *Computing Across America*.

Despite all that gear on his bike now and the book's promotion at ham and computer fests, electronics and ham radio play almost no part in the story in the book. Even computers figure only marginally in the tale. The trip covered in this book took place largely in 1984, and the bike then had relatively little electronic equipment on it. Roberts used a Radio Shack Model 100 laptop for word pro-

Table II. "PC Pursuit" Accessible Cities/Area Codes

Area Code	City & State	Area Code	City & State
404	Atlanta, GA	201	Newark, NJ
617	Boston, MA	212	New York, NY
312	Chicago, IL	602	Phoenix, AZ
216	Cleveland, OH	215	Philadelphia, PA
214	Dallas, TX	503	Portland, OR
303	Denver, CO	919	Raleigh, NC (Research Triangle Park)
313	Detroit, MI	801	Salt Lake City, UT
818	Glendale, CA	415	San Francisco, CA
713	Houston, TX	408	San Jose, CA
213	Los Angeles, CA	206	Seattle, WA
305	Miami, FL	813	Tampa, FL
414	Milwaukee, WI	202	Washington, DC
612	Minneapolis, MN		

cessing and communicating via CompuServe (one of the sponsors of the trip), but little was done with is that a terminal and/or a fax machine couldn't do.

This is really a "personal odyssey" book. On that level, it's not a bad book. Almost everyone had dreamt of traveling around the country; Steve Roberts actually did it. Although my own visions of travel run more along the lines of emulating Buzz and Todd on *Route 66* in a sports car than cycling along at a snail's pace, this doesn't detract from the drama of his trip. His descriptions of the people he meets and the places he visits are particularly interesting.

There are two problems with the book. Since it is being promoted at ham and computer fests and the author is an electronics professional/hobbyist, I expected him to at least throw "us" a few technical bones. That is, discuss in detail the electronics on the bike, the mechanics and problems of using the computer on the road, etc. But the electronics content of the book is virtually nil. Evidently, he did not have his amateur radio license in 1984 (though he does now), so all of his communication was by CB and telephone/modem.

He also overdoes the recumbent-bike-as-a-woman-trap bit and the results therefrom. The treatment of his female encounters is both heavy-handed (pun intended) and indelicate and would have been better split into another volume titled *The Many Loves of Stevie Roberts*. He also seems to have little tolerance for

those who do not share his libertine tendencies, though in the Epilogue he indicates that the fear of AIDS has made him monogamous.

Despite these qualms, it generally was an interesting book, The Epilogue also indicates that he is back on the road. I'd like to read his next book; I just wouldn't expect much technical content.

1-2-3 For Scientists and Engineers

Several months back, I discussed how spreadsheets were being under-utilized for technical calculations and gave some examples of the possibilities. *1-2-3 For Scientists and Engineers* by William J. Orvis (Sybex, \$24.95) goes a step further and delves deeply into using spreadsheets for such complex mathematics as integration, differential equations and non-linear equations.

Orvis' book expects you to have a background in science, engineering or mathematics and to already be familiar with Lotus 1-2-3, but he gives you step-by-step examples of using a spreadsheet to solve complex calculations. This book is excellently written and is well worth a place in the library of anyone who performs technical calculations.

As always, your comments and suggestions are welcome. You can contact me at P.O. Box 678, Garner, NC 27529, or by computer on Delphi (CURTPHIL), CompuServe (73167,2050) or The Source (BDK887).

ME

CONSOLIDATED ELECTRONICS

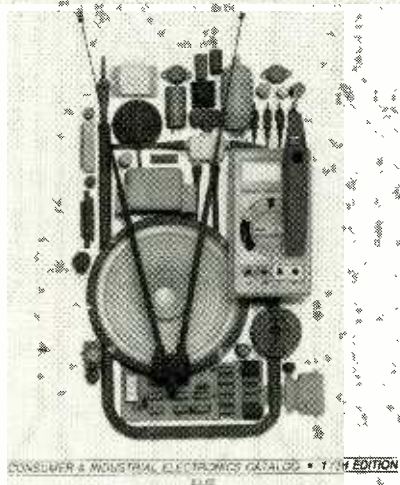

GET THE ULTIMATE ELECTRONICS CATALOG.

Order your 260 page catalogue packed with over 10,000 money saving electronic parts and equipment! Send \$3.00 check or money order, or call 1-800-543-3568 today and use your Mastercard or Visa
Consolidated Electronics, Incorporated
705 Watervliet Ave., Dayton Ohio 45420-2599

NAME _____
ADDRESS _____
CITY _____
STATE _____ ZIP _____

CIRCLE 64 ON FREE INFORMATION CARD

They're Here!

MODERN ELECTRONICS

FUN PROJECT BOOKS

You'll want these two exciting project books, packed with complete plans for building a wide variety of useful electronic devices. The *First* and *Second Books of Modern Electronics Fun Projects*, both Howard W. Sams publications, are now available.

You'll find all the how-it-works information, schematics, photos, drawings, printed-circuit guides and parts sources to make it a snap to build almost 50 useful, unique electronic devices at modest cost.

Discover how these circuits and modern electronic devices perform their magic. Learn practical electronic technology the painless way and have fun doing it!

All projects are based on material published in *Modern Electronics*, with updates and revisions. They've been built and tested by the original authors. Chapters are divided into Intro To Electronic Projects, Home Electronics, Audio/Video Electronics, Security Electronics, Computers, Test Equipment, and Electronic Designing. There's something for everyone!

Look at what you can build & take pride in:

- *Digital voltmeter accessories—high-frequency ac probe, true-rms adapter, temperature probe
- *Car projects—anti-theft alarms, engine tachometer
- *Life-saving detectors—gases & micro-wave leaks



- *Computer system power controller
 - *Dual-pulse generator
 - *Surround-sound audio enhancer
 - *Security—telephoned status reporter, alarm control center
 - *Home convenience—selectable phone ringer musical tunes, touch-sensitive light controller.
- ... and so much more.

The Fun Projects are capped by introductory information on building projects and kits (tools needed, parts sources, etc.) and advanced design techniques that illustrate how a designer thinks and plans when putting together a practical end product.

From beginning to end, MODERN ELECTRONICS FUN PROJECT BOOKS are for you! Order them today for a fast start in the world of electronics.

MODERN ELECTRONICS
76 N. Broadway, Hicksville, NY 11801

Name _____
 Address _____
 City _____
 State _____ Zip _____
 Check MasterCard VISA
 Card No. _____
 Expires _____
 Signature _____
 (Signature required on all charge orders)

Order Date: _____

QTY	Title	Price	Total
	First Book of Modern Electronics Fun Projects	\$12.95 ea.	
	Second Book of Modern Electronics Fun Projects	\$12.95 ea.	
		Total	
		*Shipping	
		Grand Total	

*Shipping charges \$2 per order. Orders processed day received, but please allow 30 days for delivery.

Macrovision . . . Now you see it, now you don't.

Remove copy-protection from video cassettes.



- Digital Filter Type, removes only Macrovision pulses
- No adjustments, crystal controlled
- Compatible with all VCR's, uses automatic vertical blanking level

Macro-Scrubber Kit - Assembles in less than three hours.

MS1-KIT \$29.95

Includes all the parts, pc board, AC adaptor and instructions from a published construction article in Radio Electronics magazine.

JMAK-4 Black Box . . . \$14.95

Original box as shown in ad with 2 feet and 4 screws to mount pc board.

Add \$2.50 shipping and handling;
\$5.50 Canadian orders.

Note: Unauthorized duplication of copyrighted material is illegal. Use Macro-Scrubber for viewing only.

72 CHANNEL MC-702 CONVERTER CABLE CONVERTER . . . \$79.95 WITH INFRA-RED REMOTE

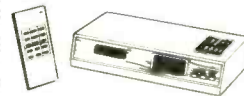

Add \$3.50 shipping & handling;
\$9.50 Canadian orders.

- 72-channel capability
- Wireless Infra-Red remote control
- Channel output 2 or 3 switchable

- Microprocessor controlled PLL operation
- Skip channel memory eliminates unused channels
- Parental control for all channels
- Last channel recall
- Fine tune memory
- UL listed/FCC approved
- Simple installation with any TV
- Includes battery and 3 foot coax cable

UNIKA SR-234 \$79.95 CABLE-READY STEREO DECODER



Connects directly to your cable box, eliminating the need for a stereo ready TV. MPX compatible too. Order today because sound does make a difference.

Add \$3.50 shipping & handling;
\$11.50 Canadian orders.

CABLEMASTER . . . \$19.95 Cable/VCR Timer

- Record multiple premium play channels
- Turns cable box on and off
- Selects channel for unattended recording
- Thousands sold nationally for \$99.95

Specify Cable TV Converter when ordering.

Add \$3.50 shipping & handling;
\$8.50 Canadian orders

ORDER TOLL FREE ANYTIME 1-800-227-8529

Inside MA: 508-695-8699

FAX: 508-695-9694
VISA, MASTERCARD,
or C.O.D.



J & W ELECTRONICS, INC.

P.O. BOX 800 • HANSFIELD, MA 02048

Copyright 1988 by J&W Electronics, Inc.

CIRCLE 77 ON FREE INFORMATION CARD

Backing Up & Benchmarking

By Ted Needleman

I recently had the experience of backing-up over 100 megabytes of hard disk, an undertaking I found a bit daunting. While I hope that you practice good backup routines, and that your requirements don't run to the size of the backup mentioned, the task did provide a good opportunity to try out a piece of software that I recently received. Back-It version 3.0, from Gazelle Systems, made the huge backup-and-restore a painless (if boring) process. Back-It is one of the new breed of programs intended to replace the backup utility supplied with MS-DOS.

When MS-DOS was first introduced with the IBM-PC, hard disks were just starting to come into common use. Today, with prices as low as \$250 to \$300, they're common. Although the DOS backup and restore utilities are appreciated, they are not the easiest utilities to use. For example, to back up an entire hard disk (on drive C:) to the floppy drive A:, the command would be similar to `BACKUP C: *.*a:/s`. The command line gets even more complex when you want to back up specific subdirectories, multiple subdirectories, and/or hidden (system) files. Contrast this with Back-It's control screen (Fig. 1).

Besides being just plain easier to use, Back-It offers several other features which make it attractive. The most important of these features is speed. When you have a lot of files to back up, you want to do it as quickly as possible. Back-It is considerably faster than DOS. To benchmark Back-It against DOS, I performed a backup of 176 files, totaling 3,451,464 bytes, on an 8-MHz IBM AT with a 1.2 Megabyte floppy. Using unformatted diskettes, Back-it took 7 minutes 50 seconds to move the files to 4 diskettes. The DOS backup utility took 14 minutes and 15 seconds to perform the same task—almost twice as long! When I repeated the test using formatted disks, Back-It blazed through the 3+ megabytes in 2 minutes 5 seconds, while DOS required 7 minutes and 35 seconds.

Actually, Back-It can go even faster

Backup Restore From-drive To-drive Directories Modified Specify Other
Start the backup process

Backup from: C to Floppies -- A:			
FILE SELECTION PARAMETERS		OTHER BACKUP PARAMETERS	
Select:	ALL FILES	Update backup flag:	YES
Subdirectories:	SEE DIRECTORY MAP	Backup verification:	NONE
Select files with dates between:	N/A and N/A	Advanced Error Correction:	YES
		Auto overwrite:	NO
FUNCTION KEY COMMANDS		BACKUP STATISTICS	
F1 - Help toggle:	ON	No. of files to back up:	*****
F2 - Enter a DOS command		Size in bytes:	*****
F9 - Recalculate statistics		No. of 360k floppy diskettes:	***
F10 - Quit		720k: *** 1.2MB: *** 1.44MB: ***	
Backup files according to the backup selections you made. You may interrupt the backup operation at any time to enter a DOS command, or you may stop the backup procedure altogether. If you need more help with backing up, please consult the manual.			
Help Screen -- Press <F1> to turn help off			

BACKIT v 3.00 - (c) Copyright 1987 Gazelle Systems Aug 9, 1988 10:24am

Fig. 1. Back-It's control screen.

than this. There are two other features that affect the speed at which Back-It operates. Back-It has three levels of verification—None, Normal, and Super. Normally, when DOS writes to a disk file, it performs a test, called a CRC (Cyclical Redundancy Check) that tests for certain errors. This is the "Normal" level of verification for both Back-It and DOS. Back-It can also perform a "Super" level of verification that actually reads what has just been written and compares it to what should have been written. This is the level of verification used in the speed tests detailed above. According to Gazelle's manual, this adds 5 percent or more to the total backup time, while considerably improving the reliability.

Back-It also allows you to turn the verification off to obtain the fastest possible speed. The problem with using this is that MS-DOS does not always lock out bad sectors during disk formatting. Gazelle claims that the combination of its own formatting routines and the advanced error correction feature they offer makes the verify-off option viable. But consid-

ering the reasons why you are making a backup in the first place, it doesn't make a lot of sense to me to take a chance on losing backed-up data to gain a minute or two quicker backup.

Back-It also features both Advanced Error Correction routines (to help recover partially corrupted files) and Advanced Error Prevention routines (to hopefully prevent the files from being corrupted). Both of these are worthy features, but add a bit to the overhead.

Gazelle's software also has some additional user features that make it pleasant to work with. You have a great deal of control over which files can be backed-up. You can choose files between two dates, those which haven't been backed up since a particular date, or by viewing a tree diagram, you can select and tag specific files and/or directories to be backed-up. The software will also take advantage of multiple disk drives, if available, switching to a second (or third or forth) drive as it finishes writing the current disk. This effectively cuts out the time involved in switching diskettes, a

factor in large backups. You still have to take out the diskette that's just been written on, of course, and insert a fresh diskette, but while you are doing this, Back-It is merrily writing to the other disk(s).

You don't even have to pre-format disks; Back-It can format them on the fly, and will even tell you how many disks are necessary to contain the files you've indicated you want backed-up.

I'm not going to preach at you, since you must know you should be backing up your hard disk and other important diskettes. Back-It isn't the only product of its type, but it is a good one. For \$129.95, it simplifies and speeds you through one of computerdom's more tedious tasks.

Measuring Computer Performance

There are times when you want to be able to evaluate a computer's performance. This may come when you're in the market for a new machine or when you just need to be able to determine whether you're getting the most out of the system you have. There are a number of methods used to evaluate how "powerful" a system is. One is to base your decision on certain specifications, such as clock speed, disk access time, and the number of wait states a particular computer's RAM memory uses. While these are all valid measures, comparing numbers alone will usually not present a fair basis of comparison.

The reason for this is that all of the above factors play a part in the system's overall performance. And just to make life more difficult, the particular application you run on the system will also affect performance ratings. A 20-MHz computer will not necessarily run PageMaker faster than a 16-MHz machine, for example, especially if the 20-MHz system uses 1 or 2 wait-state memory and a slower hard disk. This is because PageMaker is both processor and disk intensive. With many word processors, which tend to be disk intensive, a faster processor will usually have less influence on speed than a faster hard disk.

Benchmarking is a more reliable way

to compare systems, or to evaluate the effect of changing around your current one. Although the word may bring to mind a workbench full of lab equipment, benchmarking is simply the process of establishing a standard test, then applying it to either various systems or the same system before and after modifications have been made.

The exact test you choose is an arbitrary decision, except that it should test the particular areas of performance you are interested in. For example, if you wanted to measure the length of different cars, you could use as a yardstick the width of your hand, or even a piece of wood. The units of measurement you obtained would be different with each (e.g., 4.5 yards, 30 hands-width, and 9 sticks long), but you would still find it easy to tell if one car is longer or shorter than the other. The only requirement is that the benchmark you choose has some meaning to you. It doesn't make sense to measure length when what you're really interested in is how many bags of luggage the trunk will hold.

Computer performance benchmarks are easy to come by. Most of the major computer magazines have made their benchmark programs available for personal use, either by allowing you to download them from a bulletin board or by handing out disks as promotions. The problem with most of these is that while they do a good job of measuring different aspects of performance, the results may or may not have much personal meaning. After all, knowing the megaflops (Millions of Floating Point Operations Per Second) won't necessarily tell you if Wordstar will run faster on Computer A or Computer B.

Commercial benchmark systems, such as PowerMeter 1.3 from The Database Group, Inc., are better. This system offers 26 different tests which measure the CPU, memory, video, disk drives, and overall system performance. The results of these tests are integrated into a figure which is called the PowerMeter Ratio (PMR), and the test results can be stored in a built-in database allowing a variety of reports to be generated. PowerMeter

HAM RADIO IS FUN!

It's even more fun for beginners now that they can operate voice and link computers just as soon as they obtain their Novice class license. You can talk to hams all over the world when conditions permit, then switch to a repeater for local coverage, perhaps using a transceiver in your car or handheld unit.



Your passport to ham radio adventure is TUNE-IN THE WORLD WITH HAM RADIO. The book tells what you need to know in order to pass your Novice exam. Two cassettes teach the code quickly and easily.

Enclosed is my check or money order for \$15.00 or charge my

() VISA () Mastercard () Am. Express

Signature _____

Acct. No. _____

Good from _____ Expires _____

Name _____

Address _____

City _____ State _____ Zip _____

THE AMERICAN RADIO RELAY LEAGUE
225 MAIN ST.
NEWINGTON, CT 06111

CIRCLE 24 ON FREE INFORMATION CARD

PC CAPERS...

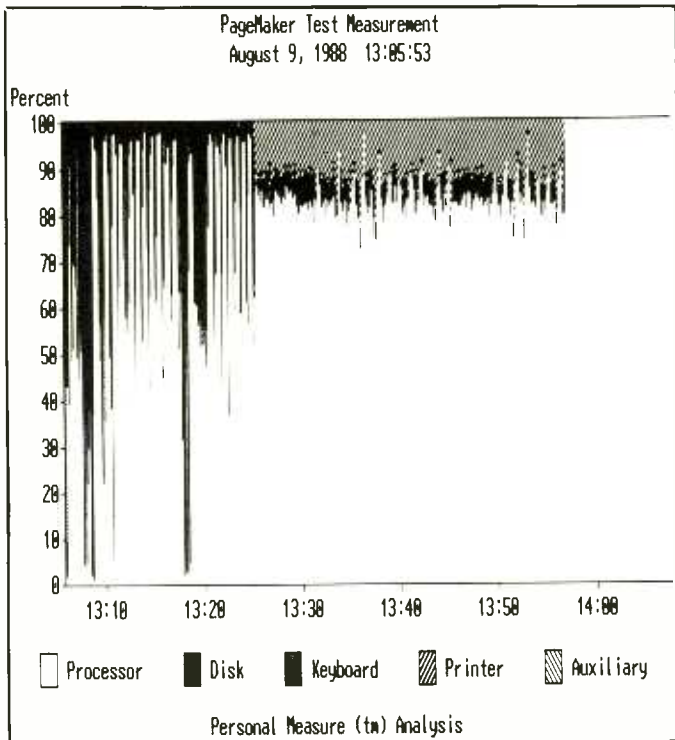

◆ Fig. 2. Personal Measure provides a reliable method of measuring computer system performance that can be graphically displayed on-screen as shown in this example.

Fig. 3. Personal Measure's performance-test results can also be printed out on paper, as in this example.

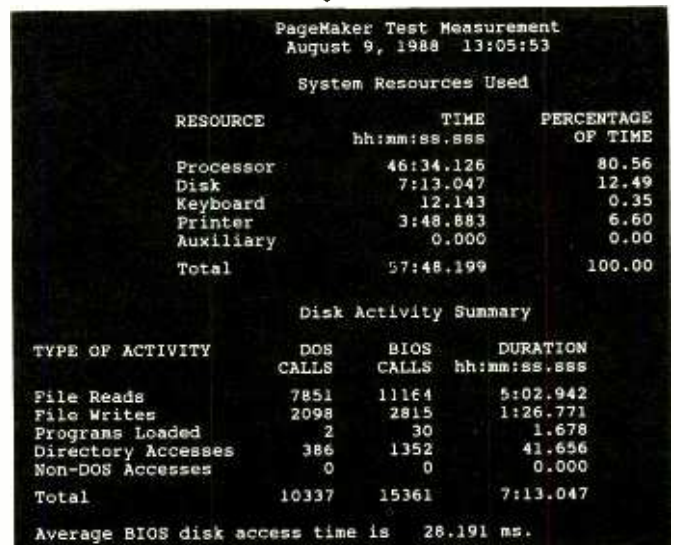

is easy to set up and use, and is a good tool if you do a lot of performance testing. Its \$89.95 price tag is not excessive.

The best set of benchmarks for most of us is, unfortunately, the most impractical. It consists of installing and running the same set of applications on the various systems to be tested. This is fine if your application set consists of small programs with simple installation procedures. If, however, your benchmark applications are similar to PageMaker, which takes between 20 and 30 minutes just to install, the benchmark process soon becomes tedious. Add the task of timing the various functions, and benchmarking soon takes a back seat to frustration.

A good compromise for the casual user who wants a reliable method of measuring performance is Personal Measure from Spirit of Performance, Inc. This \$69.95 program is a memory-resident utility that stays in the background compiling performance statistics while you run your own applications. You can

leave it active for any period of time you prefer and, upon deactivating it, write the results to a disk file. A separate program provides a graphic display or print-out of the results of the analysis, and a tabular report is also available detailing system resources used and disk activity (Figs. 2 and 3).

Personal Measure is particularly good for judging the effects of system improvements, such as disk caching and hard-disk reorganization. By running the same application along with Personal Measure both before and after the modification, you can document the degree of improvement. The same holds true for not-so-obvious system adjustments as changing the Files and Buffers statements in your CONFIG.SYS file. Each buffer you allocate with the Buffers statement eats up some memory. Once you pass the optimum number of buffers for your application, you may actually slow your system down by over-allocating buffers. Personal Measure lets you see the effect of each increase.

The Personal Measure manual is small, but adequately explains what the program is and how to use it. Since the software is menu-driven (bar menus on the bottom of the screen) and easy to use, there's not really a great need for more documentation. The manual does, however, contain a nice discussion on benchmarking, and mentions other packages available from a variety of sources, and their features.

My one criticism of Personal Measure concerns its performance graph. When printed, it loses too much detail. For example, the graph in Fig. 2 resulted from running PageMaker and printing a 20-page document. On the screen, you could see a thin green line representing keyboard usage, but it is invisible on the printout. The graph also gives a slightly unrealistic view of processor usage. This is because the sum of the component measurements in Personal Measure always add up to 100 percent. Technically, this is correct; after all, the *total* system is being used 100 percent of the time. Un-

fortunately, the processor *task* is not differentiated.

If you look at Fig. 2, in the period from about 13:25 to almost 14:00, processor use remains at an almost constant 80 to 85 percent. With this type of usage, you'd think that some processor-intensive task was being performed. Actually, all that's happening is that the processor is monitoring Window's print spooler and sending a spooled document from disk to the printer as the printer is able to accept it. In actuality, you probably could multi-task during this period without much overall system degradation.

Given that one of Personal Measure's primary uses is to help you discover bottlenecks and places where the system can be improved, I was a little disappointed. A more extensive analysis would be helpful, and hopefully this will be addressed in a future upgrade.

All things considered, though, Personal Measure is a good buy. Even if you have no immediate need for measuring performance, it's useful to know how your applications are making use of system resources. Armed with this knowledge, you can make better decisions as to what paths future upgrades and enhancements should take. **ME**

Companies Mentioned:

Back-It Version 3.1
Gazelle Systems
 42 N. University Ave.
 Provo, UT 84601
 (800) 233-0383

PowerMeter
The Database Group, Inc.
 3031 Tisch Way
 San Jose, CA 95128
 (408) 262-7766

Personal Measure
Spirit Of Performance, Inc.
 73 Wescott Rd.
 Harvard, MA 01451
 (508) 456-3889



SHORTWAVE RADIO BOOKS



Discover one of most incredible collections of electricity and electronics books to come along in years. You'll find scores of high quality new books and reprints of rare old books on building and collecting old time radios including spark-gap transmitters, crystal sets, regenerative and other antique receivers, early telephony and television, and more!

Tesla Coils!

Build Tesla coils, induction coils, Wimshurst and other lightning bolt generators! Rewind and repair motors! Design and build electrical generators! Get high power from auto alternators! You'll find quality books on these topics and much more!



Fringe Science!

You'll even discover a strange collection of books on "Fringe Science" — lost continents, perpetual motion, unusual phenomena recorded throughout the centuries, and much more. Explore the strange world that lies between fact and fiction!

Wide Variety!

You'll find plans and info on all types of unusual equipment from lasers to century-old induction coils! Build equipment your friends haven't even heard of!



Write for a catalog!

Write for your copy of Lindsay's new Electrical Books catalog and see for yourself what you've been missing! Send \$1.00 (US & Canada) or \$3.00 foreign airmail. We'll send your catalog immediately! Write today!



Lindsay's Electrical Books

PO Box 12-WE2, Bradley IL 60915

Enclosed is \$1.00. Send me a copy of Lindsay's Electrical Books catalog via first class mail!

Name _____

Address _____

City _____ St _____ Zip _____

Sidekick Plus

By John McCormick

Borland International (Scotts Valley, CA) started the TSR (Terminate and Stay Resident) craze some years ago with the introduction of its popular SideKick. This very useful software let users take notes and do simple calculations on their computer without leaving the particular applications program they were using at the time. Since then, TSR or "memory-resident" programs, have multiplied like rabbits, to the point where many people are now struggling with incompatible TSRs on their systems.

While continuing to market upgraded versions of SideKick, Philippe Kahn's Borland is now offering a far more complex, larger SideKick-like program called SideKick Plus.

Priced at \$199 (\$69.95 for upgrade from SideKick) and requiring 384K RAM, DOS 2.0 or later, a hard disk, and running on PS/2 and PC compatibles, this non-copy-protected product rivals many word processors in its document and outline creation features. It also has communications capabilities that will fill the needs of all but the most demanding modem users.

Description

The simple SideKick notepad has grown to a nine-window word processor, each with a maximum capacity of 11,000 words (54K), adjustable margins, headers, footers, tabs, and page breaks.

Nine more windows for outlines feature tree charts, tables of contents, and automatic line numbering. You can have up to 2,000 headlines (400K) and up to a 5,000-character note attached to each headline. The SK Plus outliner will read Ready!, ThinkTank, and PC Outline files and operates in a similar way to these outliners, expanding and collapsing headlines to show details or let you see "the big picture."

The Phonebook has grown, too, from an autodialer to a complete background telecommunications program, complete with Script language to automate your communications.

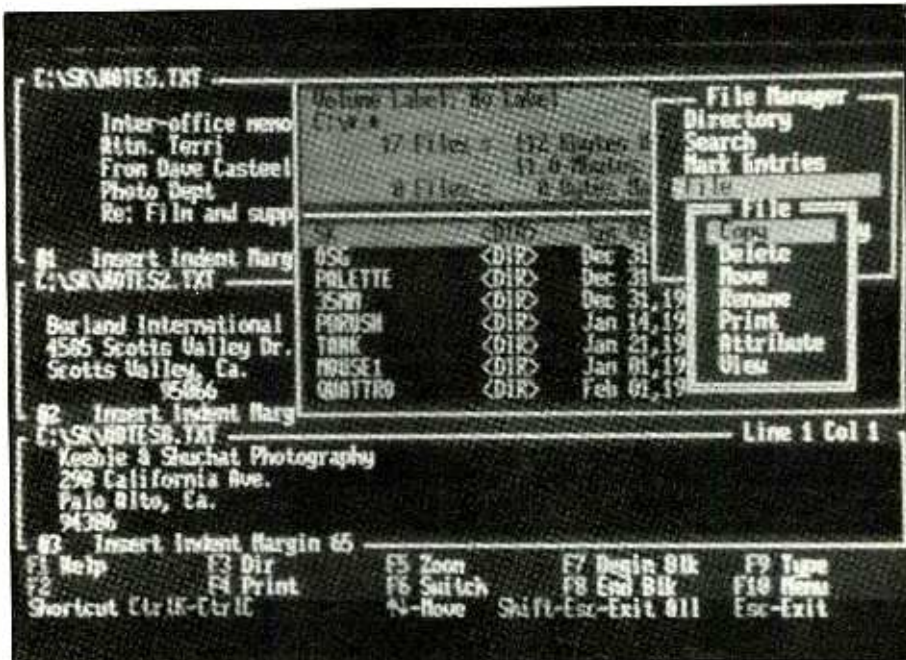

Example of SideKick Plus windows screen.

A calendar, appointment book, and schedule window, along with various alarms and attached notes, make up the time-planning functions.

Going well beyond a four-banger calculator, Business, Scientific, Programmer, and Formula calculators are included. The Formula version is the biggest and incorporates all the features of the other three, having a long list of special functions that can be selected from a small window.

The Formula calculator will evaluate a 250-character formula, uses AND, XOR, and NOT Boolean operators, and will store and recall three custom formulas. An important note for SideKick users—the calculator in SideKick Plus uses a different precedence than SideKick, performing all multiplication and division before addition and subtraction. This is covered on page 22 of the SK Plus for SK Users booklet, but many people might miss it buried in there.

The ASCII table and the fine cut-'n'-paste features of SideKick are retained.

File Manager is not a database but, in-

stead, is a handy DOS shell that helps you manage all the files on your disks. Besides copying, sorting and locating files, File Manager lets you view contents of a file in both ASCII and HEX formats.

Perhaps SideKick Plus's most important feature is its ability to format a disk while you are still in an applications program, something appreciated by everyone who has faced trying to save a file to a full disk.

Because of its powerful features and memory demands, many users will likely want to run it in a non-resident mode instead of its normal TSR configuration. This option is explained in the supplied documentation.

At 450 pages, the documentation for Plus is nearly 4.5 times longer than that needed for the smaller program and, although the instructions, being Borland, are typically well-written and arranged, they are still a handful. Experienced SideKick users will want to go directly to a separate 30-page guide intended for them.

Fortunately for new users, SK Plus is heavily menu driven, with lots of help

with a brief look into the future by discussing the possibilities of using gate and cell arrays, networking (connecting together a number of computers), the electronic office and home, artificial intelligence and robotics.

This nicely presented book has easy-to-read text and is tastefully illustrated with plenty of informative schematics, logic diagrams, photos, line drawings and tables. We would not hesitate to recommend this book to anyone who wants to obtain a good general grasp of digital techniques.

Master Guide to Electronics Circuits by Harry L. Helms. (Prentice Hall. Hard cover. 293 pages. \$32.)

This practical user's book is really a collection of hundreds of schematic diagrams for circuits that range in application across a wide spectrum of electronics. Very light on the use of text, the book relies basically on caption-like descriptions that accompany each schematic. Each of the book's 29 chapters focuses on a specific category of circuit, among them audio amplifiers, automotive circuits, digital and logic circuits, to name just a few. The only exception is chapter 29, titled Miscellaneous Circuits, which contains schematics for circuits that do not neatly fit into the categories represented by the other 28 chapters. The categories are alphabetized for easy look-up. Though within each chapter the circuits are not arranged in any particular order, locating a specific one presents no great difficulty.

Every schematic diagram is supplied with component values and or type numbers specified right on it or with an accompanying parts list. The schematics are fully detailed and ready to be used as they are as circuit-design elements or fully operational stand-alone projects. The more than 350 schematics supplied in this book cover a wide diversity of applications areas, including automotive devices, battery circuits, converters, display circuits, electro- and fiber-optic circuits, microprocessor circuits, motor-control circuits, oscillators, power supplies, receiving circuits, TV and video circuits, and much more. These schematics have been drawn from manufacturer applications notes and a variety of periodicals.

This reference book should prove exceptionally useful to anyone designing

circuits. After all, there is no need to invent the wheel. And here is a handy volume that will save you many hours of research trying to find a circuit you remember seeing somewhere.

NEW LITERATURE

Component and Equipment Catalog.

Active Electronics has just released its comprehensive 240-page 1989 catalog that lists thousands of electronic components, tools and equipment for the professional and amateur alike. Listed and fully described (including prices) in individual sections are resistors, capacitors, diodes, LEDs, transistors, digital ICs, linear ICs, displays, switches, and more. Other sections are devoted to video and TV products and accessories; test and measuring equipment (meters, oscilloscopes, signal generators, etc.); chemicals; printed-circuit products; soldering and desoldering equipment; tools; electronic kits; and books. A full index is provided for easy product look-up. For a free copy, write to: Active Electronics, 133 Flanders Rd., Dept. ME, Westboro, MA 01581.

TI Filters Video Catalog. A video tape from Microwave Filter Co. summarizes MTV/87, a catalog of filters and services for suppressing terrestrial interference (TI) in satellite systems. The video gives an overview of interference, its sources and symptoms and a listing of 500 receivers and what filters can be applied to each system. A filtering flow diagram and standard receivers illustrates fixed and tunable traps and bandpass filters for use at baseband, i-f, in the coax microwave line and at 4 GHz. Another diagram shows block downconversion receivers with an additional line of fixed and tunable notch filters for use in the block line between the downconverter and receiver. Another shot shows degrading cases of TI, from light sparklies to total picture wipe-out. Other items described are a kit of filters and accessories for diagnosing TI, a standard gain horn to determine interference frequency, stick-on absorbers to dissipate interfering microwave energy and a line of filters for commercial, military and Ku-band and SMATV cable system distribution filters. For a copy, send \$9.95 to: Linda DeCoursey, Microwave Filter Co., Inc., 6743 Kinne St., E. Syracuse, NY 13057.

Now You Can Learn Electronics From VHS Video Tape!!! UCANDO Now Has Four Video Tapes Designed For The Electronic Enthusiast.

ELECTRONICS AND YOU—PART ONE DC PRICE \$32.95

You will learn about Series circuits, Parallel circuits, the combination of Series-Parallel circuits, Ohms Law, Voltage, Current and Resistance as well as how to use the Digital multimeter.

ELECTRONICS AND YOU—PART TWO AC PRICE \$32.95

You will learn about AC theory, Coils Transformers, Capacitors, Filter circuits and how they are used in actual circuits.

VCR MAINTENANCE AND REPAIR PRICE \$32.95

This tape was designed for the average VCR user. No special tools or schooling are required for this tape. You will learn how to clean the entire tape path in the VCR as well as how to replace some of the belts in the VCR.

INTRODUCTION TO VCR REPAIR PRICE \$59.95

You will learn how the VCR Processes the Luminance, Chromance and Audio signals in the VCR, in both the playback and record modes. you will also learn about the Servo systems used to control the Capstan motor and the Video Drum Cylinder. This tape also covers many more aspects of the VCR.

ORDER YOUR TAPES NOW!

VISA and MASTER CARD are accepted. CALL: (513) 548-6113 or mail check or money order to:



P.O. Box 386
Greenville,
Ohio 45331

CIRCLE 75 ON FREE INFORMATION CARD

ATTENTION! ELECTRONICS TECHNICIANS

EARN YOUR B.S.E.E. DEGREE

THROUGH HOME STUDY

Our New and Highly Effective Advanced-Placement Program for experienced Electronic Technicians grants credit for previous Schooling and Professional Experience, and can greatly reduce the time required to complete Program and reach graduation. No residence schooling required for qualified Electronic Technicians. Through this Special Program you can pull all of the loose ends of your electronics background together and earn your B.S.E.E. Degree. Upgrade your status and pay to the Engineering Level. Advance Rapidly! Many finish in 12 months or less. Students and graduates in all 50 States and throughout the World. Established Over 40 Years! Write for free Descriptive Literature.

COOK'S INSTITUTE OF ELECTRONICS ENGINEERING

CIE 4251 CYPRESS DRIVE JACKSON, MISSISSIPPI 39212

CIRCLE 40 ON FREE INFORMATION CARD

tie a knot in the bundle about 5 inches from the end inside the enclosure. Do the same with the heavy-duty two-conductor cable. Then, referring to Fig. 5, plug the free ends of these wires into their respective holes in the circuit-board assembly and solder into place. If you did not use color-coded conductors for the wiring, use an ohmmeter or continuity checker to identify each and tag their free ends with labels that identify their destinations in the vehicle's electrical system.

Securely mount the bottom of the project's enclosure in the selected location in your vehicle with sheet-metal screws. To make the mounting resilient, place a flat washer on each of two screws and follow with a small rubber grommet. Plug the ends of the screws into the two holes you drilled in the floor of the enclosure and follow with another rubber grommet on each. Drill suitably sized holes in the metal of the vehicle at the mounting location, spaced as needed, and drive the screw ends into these holes. Tighten the screws only enough to slightly compress the rubber grommets.

Now determine where in your vehicle to mount the light-emitting diode and pushbutton RESET switch. Select a location for the LED that will provide unobstructed view of its flashing red light. A good location is somewhere near the instrument cluster, but any other location that has direct view for the driver will do.

Slip a 1-inch length of small-diameter heat-shrinkable tubing over the free ends of the conductors that go to the WARNING LED holes in the circuit-board assembly. Now determine which of the LED's leads is the cathode. Clip this lead to a length of 1/2 inch and form a small hook in the end. Crimp the free end of the LED cathode conductor coming from the project to the cathode lead of the LED and solder the connection.

Then do the same for the anode lead of the LED and the anode conductor.

Slide the heat-shrinkable tubing up over the connections until it is flat against the base of the LED and shrink solidly in place to assure good electrical insulation. Mount the LED in the selected location and, to help in further deterring a potential thief, label it ALARM ARMED.

For the RESET switch, select a location that is easily accessible but is hidden from view and will take a potential thief more than the timed period to locate. Up under the dashboard or inside the glove box are just two possibilities.

Strip 1/4 inch of insulation from both ends of a 2-inch length of stranded hookup wire. Tightly twist together the fine conductors at both ends and sparingly tin with solder. Crimp and solder one end of this wire to one lug on the pushbutton RESET switch and the other end to a ring-type lug sized to fit over the mounting shank of the switch. Place the lug over the switch's shank.

Locate the free end of the RESET switch wire coming from the project and crimp and solder this to the other lug of the switch. Mount the switch in its selected location. (Note: If the selected location is not an electrically grounded point in the vehicle, elimi-

nate the lug on the switch shank and replace it and the 2-inch wire with a sufficiently long wire to reach from the switch lug to a grounded point in the vehicle.)

Use a sheet-metal screw and toothed lockwasher to secure the GND lead to any convenient grounded point in the vehicle. If necessary, use emery cloth to burnish the selected point in the vehicle to bright, shiny metal, drill a suitably sized hole and secure this lead in place.

Use your voltmeter to determine which of the conductors in your vehicle's electrical system is at +12 volts when the keyswitch is turned to on and has no voltage on it when the keyswitch is set to off. Connect and solder the remaining No. 22 wire to this wire. To do so, you might must cut this wire to remove about 1/4-inch of insulation from both ends of the vehicle wire. Tightly twist together the stripped ends and the free end of the No. 22 wire and solder the connection. When the connection has cooled, thoroughly wrap it with electrical tape to insulate it.

This leaves only one No. 22 wire to be connected—the one that goes from the +12V hole in the circuit-board assembly to the vehicle's battery. This wire will be connected last.

Before making the connection to

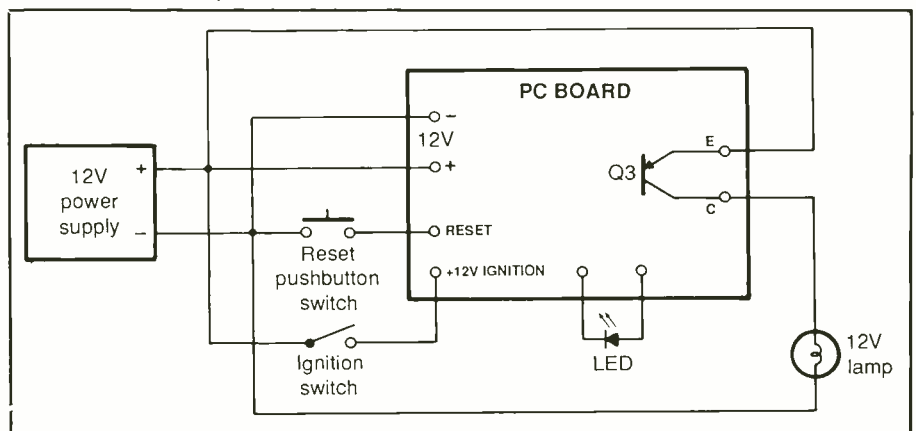

Fig. 5. Installation wiring diagram.

the vehicle's ignition module, locate the feed wire to it. This wire will be of relatively heavy gauge and will be energized only when the ignition switch is turned on. If you are not sure of which is the correct wire, consult your car dealer or a qualified serviceman.

You must cut through the power-feed wire as indicated in Fig. 5 (make sure the ignition is off first!). Prepare the cut ends of this wire by stripping away about 1/2 inch of insulation from both. Slip over the free ends of the 16-gauge wires a 2-inch length of suitable diameter heat-shrinkable tubing. Tightly twist together the free end of the Q3 COLLECTOR wire and the end of the cut vehicle's power-feed wire nearer the ignition module and solder. Do the same with the two remaining wires. When the connections have cooled, slide the heat-shrinkable tubing over them. Adjust the tubing so that the connections are in the center. Shrink the tubing solidly in place.

Finally, connect the last No. 22 wire from the +12V hole in the circuit-board assembly to the vehicle's battery. Before doing this, however, thoroughly clean all dirt, grease, corrosion and oxide scale from the battery's positive (+) terminal post and ring connector. Loosely wrap this wire around the battery cable and make the connection to the ring connector electrically and mechanically secure.

When the project has been fully installed in your vehicle, conduct one final operational check. First, initialize the circuit by turning the ignition keyswitch to on and then again to off. The LED should now be flashing. Now start your vehicle but do not press and release the RESET switch. The engine should run for the allotted period of time and then stall.

Turn the ignition keyswitch to off and then on again to restart your vehicle. This time, press the RESET

switch before the countdown period completes. This should extinguish the LED and the vehicle's engine should continue to run as it normally would.

In closing, it should be noted that this Vehicle Theft-Deterrent Device does *not* replace a standard audible alarm, though it can be used without it. If it is installed in a vehicle that is already equipped with an audible alarm that a thief defeats, he will think he has clear sailing. However, when the engine stalls, the thief is almost certain to think that he has stolen a vehicle that has ignition problems and he will depart very quickly.

Regardless of the location chosen for installation of the project module, it is always a good idea to physically secure your engine compartment

with a hood lock. Determined thieves often flip the engine hood to make a quick inspection of the contents and clip any wires that are not part of the vehicle's standard electrical system, in so doing, defeating many alarm systems, including this one. If the +12-volt lead from the vehicle's battery is cut, the Theft-Deterrent Device will be disabled and your vehicle can be driven away.

When entering your vehicle, keep in mind that the Theft-Deterrent Device will always be armed. Therefore, you *must* press and release the RESET switch after switching on the ignition or before or after you start your engine. This may present a slight inconvenience, but it is well worth it if it prevents your vehicle from being stolen! **ME**

DIGITAL VIDEO STABILIZER ELIMINATES ALL VIDEO COPYGUARDS

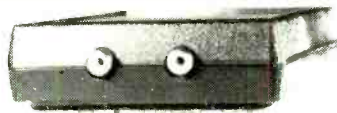

While watching rental movies, you will notice annoying periodic color darkening, color shift, unwanted lines, flashing or jagged edges. This is caused by the copy protection jamming signals embedded in the video tape, such as Macrovision copy protection. DIGITAL VIDEO STABILIZER: RXII completely eliminates all copy protections and jamming signals and brings you crystal clear pictures.

WARNING

The Digital Video Stabilizer: RXII is intended for private home use only. It is not intended to copy rental movies or copyrighted video tapes that may constitute copyright infringement.

FEATURES

- Easy to use and a snap to install
 - The best and the most exciting Video Stabilizer in the market
 - State-of-the-art micro-chip technology
 - 100% automatic - no need for any troublesome adjustments
 - Works on all types of VCRs, TVs, and Monitors
 - Light weight (8 ounces) and Compact (1x3.5x5")
 - Beautiful deluxe gift box
 - Uses a standard 9 Volt battery which will last 1-2 years.
 - Similar units sold elsewhere for \$99 or more!
 - UNCONDITIONAL 30 DAYS MONEY BACK GUARANTEE
 - FAST UPS DELIVERY
- Air Shipping available

To Order: 1-800-445-9285 or 516-694-1240

\$49 ea + \$3 for p&h

Visa, M/C, COD M-F: 9-6 (battery not included)

SCO Electronics Inc.

Dept. C17 62 Marine St. Farmingdale NY 11735

CIRCLE 65 ON FREE INFORMATION CARD

Be an FCC LICENSED ELECTRONIC TECHNICIAN!

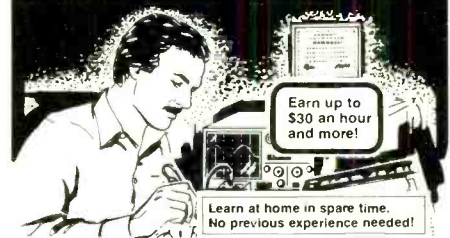

No costly School. No commuting to class. The Original Home-Study course prepares you for the "FCC Commercial Radiotelephone License". This valuable license is your "ticket" to thousands of exciting jobs in Communications, Radio-TV, Microwave, Computers, Radar, Avionics and more! You don't need a college degree to qualify, but you do need an FCC License.

No Need to Quit Your Job or Go To School

This proven course is easy, fast and low cost! **GUARANTEED PASS** — You get your FCC License or money refunded. **Send for FREE facts now. MAIL COUPON TODAY!**

COMMAND PRODUCTIONS

FCC LICENSE TRAINING, Dept. 220
P.O. Box 2824, San Francisco, CA 94126

Please rush FREE details immediately!

NAME _____
ADDRESS _____
CITY _____ STATE _____ ZIP _____

New Scanner by AOR

**100 Channels
800 MHz**

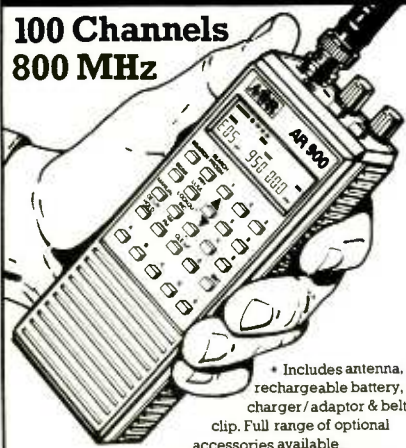

* Includes antenna, rechargeable battery, charger/adaptor & belt clip. Full range of optional accessories available

- Covers 27-54 MHz, 108-174 MHz, 406-512 MHz, and 800-950 MHz
- 5 Scan Banks and 5 Search Banks
- 25 Day Satisfaction Guarantee, Full Refund if not Satisfied
- No Frequencies cut out
- Size: 2" x 5 3/4" x 1 1/2" wt: 12 oz.

AR900

Total Price, Freight Prepaid
(Express Shipping Optional)

\$299.00



COMMUNICATIONS

10707 E. 106th St. Indpls., IN 46256

Toll Free 800-445-7717

Visa and MasterCard
(COD slightly higher)

In Indiana 317-849-2570 Collect FAX (317) 849-8794

CIRCLE 69 ON FREE INFORMATION CARD

LEARN VCR

CLEANING/MAINTENANCE/REPAIR

EARN UP TO \$1000 A WEEK, WORKING
PART TIME FROM YOUR OWN HOME!



THE MONEY MAKING OPPORTUNITY OF THE 1990'S

IF you are able to work with common small hand tools...

IF you possess average mechanical ability, and have a VCR on which to practice and learn... then we can teach YOU VCR maintenance and repair!

FACT: up to 90% of ALL VCR malfunctions are due to simple MECHANICAL or ELECTRO-MECHANICAL breakdowns!

FACT: over 77 million VCRs in use today nationwide! Average VCR needs cleaning/maintenance or repair every 12 to 18 months!

VIEJO'S 400 PAGE TRAINING MANUAL (over 500 photos and illustrations) AND COMPANION VIDEO TRAINING TAPE REVEALS THE SECRETS OF VCR MAINTENANCE AND REPAIR - "REAL-WORLD" INFORMATION, THAT IS NOT AVAILABLE ELSEWHERE! ALSO INCLUDES ALL THE INFO YOU'LL NEED REGARDING THE BUSINESS SIDE OF RUNNING A SUCCESSFUL SERVICE BUSINESS!

FREE INFORMATION

CALL TOLL FREE 1-800-537-0589

Or write to: Viejo Publications

217 E. 86th St., Suite 272 • New York, NY 10028

CIRCLE 31 ON FREE INFORMATION CARD

MODERN ELECTRONICS MART

Classified Commercial Rates: \$1 per word, 15-word minimum (\$15.00) prepaid. (Word count includes name and address; ZIP code and abbreviation each count as one word; P.O. Box number and telephone number count as two words each.) Indicate free category heading (Computers, Communications, Electronics, Video or Miscellaneous). A special heading is available for a \$6 surcharge. First word only is set boldface caps at no charge. Add 20% for additional boldface words.

Non-Commercial Rates: FREE to subscribers, as space permits; maximum 15 words. A recent MODERN ELECTRONICS mailing label must accompany ad.

(All advertisers with P.O. Box addresses must supply permanent address and telephone number. Copy is subject to publisher approval.)

Mailing Information: Copy must be received by the publisher by the 25th of the third month preceding the cover date. Send Advertising material with check or money order or credit card information (Visa or MasterCard only) with number and expiration date to: MODERN ELECTRONICS, Classified Department, 76 N. Broadway, Hicksville, NY 11801.

VIDEO

VHS-VCR repair solutions volumes I, II, III. Each contains 150 symptoms and cures, cross reference chart, free assistance. Each \$11.95, any two \$19.95, all \$29.95. Eagle Electronics Dept. A, 52053 Locks Lane, Granger, IN 46530.

CABLE TV CONVERTER/DESCRAMBLERS - Original Factory Zenith, Tocom, Scientific Atlanta, Oak, Jerrold, Panasonic - Remotes, Video Accessories, Kits. Best Buys/Warranties - **FREE CATALOG.** ARIZONA VIDEO, 3661 N. Campbell, #310-H, Tucson, Arizona 85719. (602) 323-3330.

PROJECTION TV . . . Convert your TV to project 7 foot picture . . . Easy! . . . Results comparable to \$2,500 projectors . . . **PLANS AND 8" LENS \$24.95** . . . Professional Systems available . . . Illustrated Catalog FREE . . . **MACROCOMA 15MC** Main Street, Washington Crossing, Pennsylvania 18977. Creditcard Orders 24 HRS. (215) 736-3979.

SCRAMBLING NEWS. Feature articles, product reviews, news, patents, feedback, turn-ons. Every month 20+ pages of interesting informative reading. \$24.95/yr. Sample \$3. 1989 **PRODUCT CATALOG:** \$1. Many new publications on descrambling. **SHOJIKI CORP.**, 1552P Hertel Ave., Buffalo, NY 14216. COD's (716) 874-2088.

CABLE and SUBSCRIPTION TV - secret manual. Build your own **DESCRAMBLERS.** Instructions, schematics, suppliers list for HBO, Showtime, Cinemax, UHF, adult. \$8.95, \$2.00 postage. **SATELLITE DESCRAMBLING, VIDEOCYPER II** - Schematics and audio digital theory. \$13.95, \$2.00 postage. **CABLETRONICS**, Box 30502ME, Bethesda, MD 20814.

RENTAL MOVIE STABILIZER. Connect between VCRs or to monitor. Satisfaction Guaranteed. \$59.95, \$4 handling. 1-800-338-8751.

ELECTRONICS

ROBOTICS INTERESTS NEWSLETTER \$36.00 for 12 Issues. Satisfaction Guaranteed. Sample \$5.00. Check Payable to N.R. Publications, Dept. ME2, P.O. Box 416, Webster, MA 01570-0416.

SURVEILLANCE, Electronics, Debugging, Protection. Latest High Tech Kits. Catalog \$2.00. **TECHNOLOGY SERVICES**, 829 GINETTE Street, Gretna, LA 70056.

LASERS and OPTICAL COMPONENTS. Write for free catalogue. M.J. Neal Co., 6672 Mallard Court, Orient, OH 43146. 614-877-3719.

EXOTIC Electronics Devices like James Bonds. Catalog, \$2.00. F&P Enterprises, Box 51272, Palo Alto, CA 94303-H.

VOICE Disguisers! FM Bugs! Telephone Transmitters! Phone Snoops! More! Catalog \$1.00: **XANDI ELECTRONICS**, Box 25647, "CC", Tempe, AZ 85282.

\$\$\$\$\$ SUPER SAVINGS \$\$\$\$\$

on electronic parts, components, supplies and computer accessories. Free 40-page catalog for self-addressed and stamped envelope. Get on our mailing list. **BCD ELECTRO**, P.O. Box 830119, Richardson, TX 75083 or call (214) 343-1770.

TUBES, Name Brands, New, 80% Off List, Kerby, 298 West Carmel Drive, Carmel, IN 46032.

PROTECT YOURSELF FROM ELECTRONIC EAVESDROPPING! Scrambler phones, transmitter detector, tape recorder detectors, executive security products, surveillance books and much more! Catalog \$3.00 (refundable). **DIVERSIFIED WHOLESALE PRODUCTS**, PO Box 1275, Redondo Beach, CA 90278.

WANT TV knobs for 1955 Motorola. Miss McClure, 210 Columbus Avenue #512, San Francisco, CA 94133.

PICTURE flyer lists quality electronic parts at low prices. Since 1970. Send for 3 sample issues. Star-Tronics, Box 683, McMinnville, OR 97128.

MICROCONTROL User Newsletter: Technical information and application notes for control system. Quarterly. \$2.50 Yr, US., \$5.00 Foreign. H.H.S. Microcontrollers, 5876 Old State, Edinboro, PA 16412.

TELEPHONE Tap. Monitor room or telephone conversations. Range Unlimited. Catalog \$3.00 (refundable). LISTEN, 603 Elgin, Muskogee, OK 74401. 1-800-633-TAPS.

MAKE money at home. Complete golf handicapping system for Commodore 64/128. Menu-driven, reports, prints cards: \$39.95. Inquire even if you have no hardware. Arrangements can be made. Handyscore, Box A101, Findlay, OH 45839 (419) 424-1986.

COMMODORE/AMIGA CHIPS, PARTS, DIAGNOSTICS. Low cost repairs. Heavy duty power supply for C64-\$27.95 plus UPS. Karsa Microsystems, Inc., 341 Route 306, Wesley Hills, NY 10952, 1-800-248-2983.

BUILD turbo XT microcomputers! FREE information: Art's Publications, 13540 Hubbard, Suite 12A, Sylmar, CA 91342.

COMMUNICATIONS

COMMUNICATIONS PLANS, BOOKS, KITS! AM/FM broadcasting (licensed/unlicensed), 1750 Meter transceivers, ham/CB amplifiers, surveillance bugs, more! FREE catalog, PAN-COM, Box 130-ME11, Paradise, CA 95967.

CB RADIO OWNERS! We specialize in technical information, parts and services for CBs. Repair/modification books, plans, kits, 10-Meter and FM conversions, high-performance accessories. Catalog \$2. CBCI, Box 31500ME, Phoenix, AZ 85046.

SATELLITE RECEIVERS, Regency SR3500, with discreet and matrix stereo, block downconverter included, \$150.00. Gordy's Repair Shop, RFD #1, Box 105D, Bowdoinham, ME 04008, phone number is (207) 666-3356.

223MHZ FM Voice Transceiver on paper route budget! Laketek Electronics, Box 2496-ME, Sandusky, OH 44870.

EDUCATION & INSTRUCTION

LEARN NEW SKILLS FAST THROUGH OUR SHORT SPECIALIZED HOME STUDY COURSES. CONDENSED AND HIGHLY EFFECTIVE! YOUR PASSPORT TO SUCCESS! 50 DIFFERENT COURSES. DIPLOMA AWARDED! OVER 40 YEARS EXPERIENCE IN HOME STUDY EDUCATION. WRITE: CIEE-14, BOX 20345, JACKSON, MS 39209.

CABLE

CABLE TV Secrets - the outlaw publication the Cable Companies tried to Ban. HBO, Movie Channel, Showtime, Descramblers, Converters, etc. Suppliers List Included. \$8.95. Cable Facts, Box 711-ME, Pataskala, Ohio 43062.

CABLE TV EQUIPMENT

CABLE DESCRAMBLER LIQUIDATION. Major makes and models available. Industry pricing! (Example: Hamlin Combo's, \$44 each . . . minimum 10 orders). **DEALERS ONLY!** Call West Coast Electronics, (818) 989-0890.

SATELLITE TV

SAVE \$\$\$\$\$ - SYSTEMS UPGRADES United, Houston, Etc. **FREE** Catalog 218-739-5231. SKYVISION, 2014 Collegeway, Ferguson Falls, MN 56537.

CABLE T.V. CONVERTERS WHY PAY A HIGH MONTHLY FEE?

All Jerrold, Oak, Hamlin, Zenith, Scientific Atlanta, Magnavox and all specialized cable equipment available for shipment within 24 hours. For fast service MC/VISA or C.O.D. telephone orders accepted (312) 638-5320 60 Day Warranty (Quantity Discounts) 8 A.M. to 5 P.M. Monday through Friday Central Time. Stamp Envelope (60¢ postage) for FREE Catalog.

Midwest Electronics Inc.

5143 W. Diversey • Chicago, IL 60639
No Illinois Orders Accepted

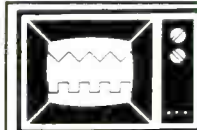

FINALLY!

An interesting and worthwhile project. This EASY-TO-BUILD circuit lets you use any regular TV set as a simple OSCILLOSCOPE. Build for less than \$10! NO MODIFICATIONS TO TV! Single or dual trace. Send for FREE CATALOG of other plans and kits.

DETAILED PLANS: \$4.95

TV-SCOPE
PENN RESEARCH, Box 3543
Williamsport, PA 17701

MICRO MART

508 Central Ave.
Westfield, NJ 07090
(201) 654-0008

HI SPEED LOW POWER SPECIAL 745C IC'S	74151 55 74LS138 45 74LS271 75	74156 55 74LS139 40 74LS272 85	74157 55 74LS140 40 74LS273 190	74158 55 74LS141 40 74LS274 250
74LS138 25 74LS141 60 74LS157 40 74LS174 140	74LS138 25 74LS141 60 74LS157 40 74LS174 140	74LS138 25 74LS141 60 74LS157 40 74LS174 140	74LS138 25 74LS141 60 74LS157 40 74LS174 140	74LS138 25 74LS141 60 74LS157 40 74LS174 140
CMS	74LS293 25 74LS297 70 74LS314 60 74LS315 25	74LS293 25 74LS297 70 74LS314 60 74LS315 25	74LS293 25 74LS297 70 74LS314 60 74LS315 25	74LS293 25 74LS297 70 74LS314 60 74LS315 25
TTL Series	7400 25 74LSXX	7401 20 74LS00	7402 25 74LS01	7403 25 74LS02
7404 25 74LS03	7405 25 74LS04	7406 25 74LS05	7407 25 74LS06	7408 25 74LS07
7409 25 74LS08	7410 25 74LS09	7411 25 74LS10	7412 25 74LS11	7413 25 74LS12
7414 25 74LS13	7415 25 74LS14	7416 25 74LS15	7417 25 74LS16	7418 25 74LS17
7419 25 74LS18	7420 25 74LS19	7421 25 74LS20	7422 25 74LS21	7423 25 74LS22
7424 25 74LS23	7425 25 74LS24	7426 25 74LS25	7427 25 74LS26	7428 25 74LS27
7429 25 74LS28	7430 25 74LS29	7431 25 74LS30	7432 25 74LS31	7433 25 74LS32
7434 25 74LS33	7435 25 74LS34	7436 25 74LS35	7437 25 74LS36	7438 25 74LS37
7439 25 74LS38	7440 25 74LS39	7441 25 74LS40	7442 25 74LS41	7443 25 74LS42
7444 25 74LS43	7445 25 74LS44	7446 25 74LS45	7447 25 74LS46	7448 25 74LS47
7449 25 74LS48	7450 25 74LS49	7451 25 74LS50	7452 25 74LS51	7453 25 74LS52
7454 25 74LS53	7455 25 74LS54	7456 25 74LS55	7457 25 74LS56	7458 25 74LS57
7459 25 74LS58	7460 25 74LS59	7461 25 74LS60	7462 25 74LS61	7463 25 74LS62
7464 25 74LS63	7465 25 74LS64	7466 25 74LS65	7467 25 74LS66	7468 25 74LS67
7469 25 74LS68	7470 25 74LS69	7471 25 74LS70	7472 25 74LS71	7473 25 74LS72
7474 25 74LS73	7475 25 74LS74	7476 25 74LS75	7477 25 74LS76	7478 25 74LS77
7479 25 74LS78	7480 25 74LS79	7481 25 74LS80	7482 25 74LS81	7483 25 74LS82
7484 25 74LS83	7485 25 74LS84	7486 25 74LS85	7487 25 74LS86	7488 25 74LS87
7489 25 74LS88	7490 25 74LS89	7491 25 74LS90	7492 25 74LS91	7493 25 74LS92
7494 25 74LS93	7495 25 74LS94	7496 25 74LS95	7497 25 74LS96	7498 25 74LS97
7499 25 74LS98	7500 25 74LS99	7501 25 74LS100	7502 25 74LS101	7503 25 74LS102

EPROM
2716 32K
2724 32K
2725 32K
2726 32K
2727 32K
2728 32K
2729 32K
2730 32K
2731 32K
2732 32K
2733 32K
2734 32K
2735 32K
2736 32K
2737 32K
2738 32K
2739 32K
2740 32K
2741 32K
2742 32K
2743 32K
2744 32K
2745 32K
2746 32K
2747 32K
2748 32K
2749 32K
2750 32K
2751 32K
2752 32K
2753 32K
2754 32K
2755 32K
2756 32K
2757 32K
2758 32K
2759 32K
2760 32K
2761 32K
2762 32K
2763 32K
2764 32K
2765 32K
2766 32K
2767 32K
2768 32K
2769 32K
2770 32K
2771 32K
2772 32K
2773 32K
2774 32K
2775 32K
2776 32K
2777 32K
2778 32K
2779 32K
2780 32K
2781 32K
2782 32K
2783 32K
2784 32K
2785 32K
2786 32K
2787 32K
2788 32K
2789 32K
2790 32K
2791 32K
2792 32K
2793 32K
2794 32K
2795 32K
2796 32K
2797 32K
2798 32K
2799 32K
2800 32K
2801 32K
2802 32K
2803 32K
2804 32K
2805 32K
2806 32K
2807 32K
2808 32K
2809 32K
2810 32K
2811 32K
2812 32K
2813 32K
2814 32K
2815 32K
2816 32K
2817 32K
2818 32K
2819 32K
2820 32K
2821 32K
2822 32K
2823 32K
2824 32K
2825 32K
2826 32K
2827 32K
2828 32K
2829 32K
2830 32K
2831 32K
2832 32K
2833 32K
2834 32K
2835 32K
2836 32K
2837 32K
2838 32K
2839 32K
2840 32K
2841 32K
2842 32K
2843 32K
2844 32K
2845 32K
2846 32K
2847 32K
2848 32K
2849 32K
2850 32K

MISC IC'S
2901 101
2902 101
2903 101
2904 101
2905 101
2906 101
2907 101
2908 101
2909 101
2910 101
2911 101
2912 101
2913 101
2914 101
2915 101
2916 101
2917 101
2918 101
2919 101
2920 101
2921 101
2922 101
2923 101
2924 101
2925 101
2926 101
2927 101
2928 101
2929 101
2930 101
2931 101
2932 101
2933 101
2934 101
2935 101
2936 101
2937 101
2938 101
2939 101
2940 101
2941 101
2942 101
2943 101
2944 101
2945 101
2946 101
2947 101
2948 101
2949 101
2950 101
2951 101
2952 101
2953 101
2954 101
2955 101
2956 101
2957 101
2958 101
2959 101
2960 101
2961 101
2962 101
2963 101
2964 101
2965 101
2966 101
2967 101
2968 101
2969 101
2970 101
2971 101
2972 101
2973 101
2974 101
2975 101
2976 101
2977 101
2978 101
2979 101
2980 101
2981 101
2982 101
2983 101
2984 101
2985 101
2986 101
2987 101
2988 101
2989 101
2990 101
2991 101
2992 101
2993 101
2994 101
2995 101
2996 101
2997 101
2998 101
2999 101
3000 101

LINEAR IC'S
LM111 50
LM112 50
LM113 50
LM114 50
LM115 50
LM116 50
LM117 50
LM118 50
LM119 50
LM120 50
LM121 50
LM122 50
LM123 50
LM124 50
LM125 50
LM126 50
LM127 50
LM128 50
LM129 50
LM130 50
LM131 50
LM132 50
LM133 50
LM134 50
LM135 50
LM136 50
LM137 50
LM138 50
LM139 50
LM140 50
LM141 50
LM142 50
LM143 50
LM144 50
LM145 50
LM146 50
LM147 50
LM148 50
LM149 50
LM150 50
LM151 50
LM152 50
LM153 50
LM154 50
LM155 50
LM156 50
LM157 50
LM158 50
LM159 50
LM160 50
LM161 50
LM162 50
LM163 50
LM164 50
LM165 50
LM166 50
LM167 50
LM168 50
LM169 50
LM170 50
LM171 50
LM172 50
LM173 50
LM174 50
LM175 50
LM176 50
LM177 50
LM178 50
LM179 50
LM180 50
LM181 50
LM182 50
LM183 50
LM184 50
LM185 50
LM186 50
LM187 50
LM188 50
LM189 50
LM190 50
LM191 50
LM192 50
LM193 50
LM194 50
LM195 50
LM196 50
LM197 50
LM198 50
LM199 50
LM200 50
LM201 50
LM202 50
LM203 50
LM204 50
LM205 50
LM206 50
LM207 50
LM208 50
LM209 50
LM210 50
LM211 50
LM212 50
LM213 50
LM214 50
LM215 50
LM216 50
LM217 50
LM218 50
LM219 50
LM220 50
LM221 50
LM222 50
LM223 50
LM224 50
LM225 50
LM226 50
LM227 50
LM228 50
LM229 50
LM230 50
LM231 50
LM232 50
LM233 50
LM234 50
LM235 50
LM236 50
LM237 50
LM238 50
LM239 50
LM240 50
LM241 50
LM242 50
LM243 50
LM244 50
LM245 50
LM246 50
LM247 50
LM248 50
LM249 50
LM250 50
LM251 50
LM252 50
LM253 50
LM254 50
LM255 50
LM256 50
LM257 50
LM258 50
LM259 50
LM260 50
LM261 50
LM262 50
LM263 50
LM264 50
LM265 50
LM266 50
LM267 50
LM268 50
LM269 50
LM270 50
LM271 50
LM272 50
LM273 50
LM274 50
LM275 50
LM276 50
LM277 50
LM278 50
LM279 50
LM280 50
LM281 50
LM282 50
LM283 50
LM284 50
LM285 50
LM286 50
LM287 50
LM288 50
LM289 50
LM290 50
LM291 50
LM292 50
LM293 50
LM294 50
LM295 50
LM296 50
LM297 50
LM298 50
LM299 50
LM300 50

TRANSISTORS
9VDC 500ma Wall Plug \$3.95
12VDC 400ma Wall Plug \$5.95
6.3V 1 2A \$1.60
9.4V 1 2A \$3.95
12.6VCT 1 25A \$3.50
7A Tapped 7.5/15VAC or 9V/18VAC @ 7A \$4.50

MOTORS
DC Permanent Magnet, Shielded Variable Speed with Reverse Rotation Possible
#M13 - 6V 28ma 480ma (MAX) 1" 25" x 1" \$1.25
#M20 - 13.2V 180ma 480ma with Pulley \$1.50
2400 RPM Governed/Adjustable with Trimmer
#MB - 12V 20ma 460 (MAX) 1" 5" x 1" \$1.00

WEARERS

4 OHM 2W 4"	90	8 OHM 2W (MAX) 4"	\$1
4 OHM 2 1/2 W 4"	95	8 OHM 3W 4.5"	\$1.50
8 OHM 2W 2 1/4"	75	8 OHM 5W 6"	\$3.25
8 OHM 5W 3"	75	8 OHM Metal 5"	\$4
8 OHM 1W 2"x1 1/4"	85	10 OHM 25W 2"	75

TOKO KITS FOR FEB '84 TV PROJECT

Toko #1's BKAN-K5552AX(X)2 #E520HN-3000023
1 107UH Ind L-2 (12UH) Fixed 1 Set of 4 Pcs \$6.00
3 Set \$15.00, 10 Set \$45.00
Car Converter - 12VDC in to 9VDC Out - 600 mg \$1
5 Cord to Fem Jack - Plugs in to Lighter \$1
11/4" Female (Stereo Headphone) Jack 2/51
3/16" Female (Walkman) Microphone Jack 3/51
Microphone for Tape Recorder 95
2 Inch Mini Cassette Memo Tape +MT30 75
Panel Meter Movements 4" Square 4/51
50K Dual Pot Audio Taper 8/51
1.000uF 25V Radial Mini Lytic 4/51
Rotary Switch - 5 Function Selector 85
6V DPDT Mini Relay (Fits 16 Pin Skt) \$1.95
25V 10A 250VAC/30VDC Omron Relay \$2.25
FM IF Transformer Assortment 15/51
Stereo Tuner Dial Pointer Indicators 15/51
CommODORE Keyboard & Motherboard Combo. \$15
VIC-16 Motherboard & VIC-16 Keyboard \$15
Opn Isolated H-1AX (Transistor Type) 65
Line Cord 6 Feet UL Listed SPT 2 \$24.95
Scope Probe Set w/Everything x1x10 \$1.95
Zener Ass't - 65 pcs 1W Devices \$1.95
Resistor Ass't - 1,000 pcs 35 Values Minimum
Popular Values (1K, 10K, 100K) included Mostly 1/4" & 1/2" W - Same Lot of Precision
Carbon Film Taped and Reeled For Easy Sorting \$9.95
Jumper Plugs (Cambion) - Male to Male For Breadboard & Connectors 10/51, 25
3 1/2" Sp. 115V \$5.95
1.5A 50V Bridge (TO-5) \$4.95
4A 50V Bridge (KBUS) 75
6A 60V Bridge 5/8" Square \$1.00
25A 200V Bridge (Soldier Lug Type) \$2.00
12VDC SPST Reed Relay PC Mount 6/51
SPST PB Switch (Keyboard Type) 5/51
Mini Toggle DPDT (Lock Latch Feature) 75
DPDT "Snap In" Rocker with But Socket 95
Pushbutton Switching (No Bulb) Off - MOM 45
Pushbutton DPST Off-MOM PC Mount 3/51
DPDT Push Button 6A 125V 3/51
DPDT "Bart" Handle Toggle (On Off On) \$1.65
DPDT RT Angle Mini PC Toggle (On Off On) 65
22uf 35v 50m Tantulum (Kemet) 3/51, 100
Radial Lytics - 1uf 50V 13, 2.2uf 50V 13, 3.3uf 50V 14, 4.7uf 40V 12, 10uf 50V 14, 22uf 35V 15, 33uf 35V 15, 47uf 35V 15, 100uf 35V 20, 220uf 35V 22, 330uf 35V 33, 470uf 35V 39, 1000uf 16V 45, 1.000uf 75V Axial 75
3.200uF 50V Twtst Lock 85
3.300uF 50V Axial Lytic 65
Ceramic Monolithics - All 50V or Higher, 330pF, 470pF, 0.01uF, 0.01uF, 0.022uF, 0.027uF, 0.033uF, 0.039uF (All 30/51) 0.1uF 10/51, 0.22uF 15/51, 1uF 10/51, 22uF 10/51

Crystal Clock Oscillator

14.3760 MHz CKIC	50
UCN4116B - OSC/Freq Div Clock IC	5/51, 100
AM/FM Radio IC w/Data Sheet (#2204)	15/51, 100
Slide Pots - 1 Each 50K, 100K, 1.2M, 2M, 5M	\$1.00
ULN 2231 (Deico DM-50) Dual Preamp IC	2/1
MRP-501 (Hobby - You Test)	10/51
Piher PT110V 3/8" Horizontal Mount Trimpts	100 Ohm 1K, 5K, 10K, 20K, 50K, 100K, 200K, 500K, 1M Single Turn 4/51
Multi Turn Precision Trimpts, 100 Ohm, 200 Ohm, 500 Ohm, 1K, 2K, 5K, 10K, 20K, 50K, 100K, 200K, 250K, 500K, 1Meg - 75 Each, 100/56	
Zenith TV Replacement IC Special	\$1 Each
221-42, 221-43, 221-45, 221-48, 221-69, 221-79, 221-87, 221-96, 221-104, 221-105, 221-106, 221-107, 221-108, 221-109, 221-110, 221-111, 221-112, 221-113, 221-114, 221-115, 221-116, 221-117, 221-118, 221-119, 221-120, 221-121, 221-122, 221-123, 221-124, 221-125, 221-126, 221-127, 221-128, 221-129, 221-130, 221-131, 221-132, 221-133, 221-134, 221-135, 221-136, 221-137, 221-138, 221-139, 221-140, 221-141, 221-142, 221-143, 221-144, 221-145, 221-146, 221-147, 221-148, 221-149, 221-150, 221-151, 221-152, 221-153, 221-154, 221-155, 221-156, 221-157, 221-158, 221-159, 221-160, 221-161, 221-162, 221-163, 221-164, 221-165, 221-166, 221-167, 221-168, 221-169, 221-170, 221-171, 221-172, 221-173, 221-174, 221-175, 221-176, 221-177, 221-178, 221-179, 221-180, 221-181, 221-182, 221-183, 221-184, 221-185, 221-186, 221-187, 221-188, 221-189, 221-190, 221-191, 221-192, 221-193, 221-194, 221-195, 221-196, 221-197, 221-198, 221-199, 221-200, 221-201, 221-202, 221-203, 221-204, 221-205, 221-206, 221-207, 221-208, 221-209, 221-210, 221-211, 221-212, 221-213, 221-214, 221-215, 221-216, 221-217, 221-218, 221-219, 221-220, 221-221, 221-222, 221-223, 221-224, 221-225, 221-226, 221-227, 221-22	

Electronic Greeting Card *(from page 28)*

spective locations. Make sure their leads go into the appropriate holes before doing any soldering. If you examine the molded plastic cases of the LEDs, you'll note a flat on the perimeter of their bases. This flat is near the cathode leads in all cases. Alternatively, if there's no flat, the cathode will be the shorter of the two leads. Note in Fig. 3 that all LEDs mount on the board in the *same* orientation, their cathode leads plugging into the holes nearer the top of the "tree."

Do *not* mount the LEDs with the bottoms of their cases flush against the surface of the pc board. Instead, leave at least $\frac{1}{8}$ inch of space between the LEDs and board. Also, use soldering heat sparingly to avoid heat damage to the LEDs. Either clip a heat sink onto each lead as you solder it into place or solder only one lead of each LED to its copper pad at a time, returning to solder the other lead when you are done with the first lead of all nine LEDs. This way, the LEDs will have time to cool off between soldering operations.

Snap-on battery connectors for *BI* can be salvaged from old dead 9-volt batteries or can be purchased new. If you salvage the connectors, cut away the plastic parts, since all you need are the metal connectors themselves. Once you have as many connectors as needed, you can use No. 2 machine hardware to fasten them to the boards and make the required electrical connections. The alternative is to solder the connectors directly to the appropriate copper pads on the solder side of the boards. Once again, observe polarity! If you're in doubt as to which snap connector goes to which pad on the circuit boards, check polarity against a 9-volt transistor battery.

Finally, install and solder into place the integrated circuit. This is a CMOS device and should be handled with the same precautions you would use for any other MOS device. Use a grounded soldering tip to solder its

pins to the copper pads on the bottom of the board. (Note: Though you can use a socket for the IC, it's not necessary and will only add unnecessarily to the cost of your "card.")

Snap a 9-volt battery into the connectors at the bottom of each circuit-board assembly in turn and note LED activity. If one or more pairs of LEDs do not blink, the problem can usually be traced to a reversed LED or electrolytic capacitor. Make any corrections to get the boards operating as they should. Once your "cards" are functioning properly, spray a coat of clear acrylic over the entire solder side of the boards to keep the copper bright and shiny.

A project like this invites artistic license. In fact, the components for this project were chosen for their appearance rather than values. For example, red LEDs, red/green/red-coded 2.7-megohm resistors, bright green 0.1-microfarad capacitors and light and dark blue electrolytic capacitors really stand out as lights and ornaments on the green trees.

Any color light-emitting diodes can be used in this project for variety. Two-color LEDs are particularly interesting because they can be wired to blink alternately red and green. A CD40106 or 74C14 hex Schmitt-trigger inverter can be substituted for *ICI* with suitable component additions to blink six pairs of LEDs instead of the four described above and shown in Fig. 1.

As an alternative to the tree shape shown in Figs. 2 and 3, you might want to fashion a star, octagonal ornament or other shape suitable to the holiday season. In fact, a variety of shapes can be given to different people as "personalized" gifts. Here's an idea for the basic tree-shape card festooned with red LEDs: when the holiday season is over, the project can be turned on its side and hung near a door or stairway where it will serve as an "exit" sign that can be seen at night!

INVENTORS

INVENTORS! Can you profit from your idea? Call AMERICAN INVENTORS CORPORATION for free information. Over a decade of service, 1-800-338-5656. In Massachusetts or Canada call (413) 568-3753.

INVENTORS

INVENTORS! Have idea for product or invention, don't know what to do? Call AIM we present ideas to manufacturers - Toll Free US and Canada 1-800-225-5800.

MISCELLANEOUS

ASIAN LADIES want correspondence for friendship, marriage, SUNSHINE INTERNATIONAL, Dept. TW, Box 5500, Kailua-Kona, HI 96745. (808) 325-7707.

IDEAS, inventions, technology wanted! Call free 1-800-288-IDEA. ISC-MOEL, 903 Liberty, Pittsburgh, PA 15222.

ADVERTISERS' INDEX

RS#		Page #
41	AMC Sales	88
24	ARRL	79
69	Ace Communications	92
37	All Electronics	94
30	C&S Sales	9
90	Chemtronics, Inc.	88
98	Cleveland Institute of Elec.	25
-	Command Productions	91
64	Consolidated Electronics	76
40	Cook's Institute	89
48	Deco Industries	94
120	Digi-Key Corp.	93
42	Digital Research Computers	94
-	Electronic Book Club	31
-	Fordham Radio Supply	Cov. II
-	Grantham College of Engineering	1
21	Hal-Tronix, Inc.	87
117	Heath Company	Cov. III
77	J & W Electronics, Inc.	77
19	Jan Crystals	71
152	Lindsay Electrical Books	81
26	Logical Devices	Cov. IV
158	MCM Electronics	71
43	Micro-Mart	95
-	Midwest Electronics	95
-	NRI Schools	15
74	OptoElectronics	3
-	Pacific Cable Co., Inc.	5
70	Parts Express International	4
-	Penn Research	95
65	SCO Electronics, Inc.	91
-	Trans World Cable Co.	94
75	UCANDO, Inc.	89
39	United Electronic Supply	11
31	Viejo Publications	92
-	Visitect Inc.	94

Heathkit®



Anyone Can Buy Top Notch Audio. Now You Can Build It.

With Heath's new build-them-yourself stereo components, you create your own sound system.

Specially designed for Heath by industry leader Harman Kardon, our new stereo line exceeds the standards of even the most discerning audiophile. And because most of the components come in kit form, you experience firsthand how electronic craftsmanship results in premium hi-fi performance.

Build the power amplifier, preamplifier and stereo tuner. Prewired and pretested circuit boards and minimal soldering mean each component takes only a few evenings to build.

And, your success is guaranteed. Our precise, step-by-step manuals are industry-recognized, and our technical assistance team is just a phone call away.

To complete your sound system, add the remote control compact disk player, cassette deck and any of our fine speakers and headphones.

Technical excellence. Do-it-yourself pride. That's what we promise. That's what you get.

Heath Company brings you a wide range of innovative electronic products, each backed by our 40-year reputation for excellence in design, quality and durability.

Heath's new hi-tech audio components are just a few of the fine products you'll see in the Heathkit catalog. Discover 108 pages packed with TVs, VCRs, computers, test instruments, radio control vehicles and so much more. For your **FREE** copy call 24 hours a day TOLL-FREE:

1-800-44-HEATH (1-800-444-3284)

CIRCLE NO. 117 ON FREE INFORMATION CARD

Heath Company



© 1986, Personal CAD Systems, Inc.

The fastest way through customs.

THE PLD DESIGN LANGUAGE WITH SOMETHING TO DECLARE.

You've probably heard about the advantages of programmable logic devices (PLD's) over conventional TTL. In design flexibility, for example. Or increased functional density. Perhaps you've learned the hard way: a competitor using PLD's has beaten you to market with a new product.

What you may *not* have heard, though, is that just switching to PLD's isn't enough. You've got to choose the right PLD design language, too.

FREEDOM OF CHOICE.

CUPL™ is the one language you can apply to any PLD design. Whatever your PLD device. Whatever your programmer. Whatever your design workstation. And whatever form of design expression you choose. With CUPL, you can even write a logic specification for a PLD before you decide on the target device.

And that means simplified training. Common data structures and design rules. Consistent documentation and testing. Instant adaptability to new devices. The productivity gains with CUPL just keep mounting. In the design cycle. And in production.

POWER TOOL.

CUPL is the most powerful high-level design language for PLD's. It incorporates features like macro substitution, free-form comments, indexed variables and parenthetical capability, to speed program development.

CUPL provides superior state machine capability, and supports all popular models of logic description, including truth tables and high-level equations.

CUPL's logic minimizers (3 are supplied), and deMorgan expansion capability are unequalled.

And CUPL's documentation out-

put file gives you invaluable feedback on your design's progress. These features, plus continual enhancements, make CUPL the benchmark in PLD design languages — flexible and powerful enough for the most sophisticated logic designer's needs.

CUPL™

Now available from Logical Devices, the new version CUPL 2.5 for MS-DOS, VAX-VMS, UNIX C, SUN 386i, and, soon to be announced, for the Apple Mac II® systems.

Also available from Logical Devices, a full line of PROM/PLD programmers.

1201 N.W. 65th Place
Fort Lauderdale, Florida 33309

Toll Free: 800-331-7766

In Florida: (305) 974-0967

Telex: 383 142 LOGICALTX

Fax: (305) 974-3531

LOGICAL
DEVICES, INC.

