

ICD 08559

MODERN ELECTRONICS™

APRIL 1986 \$1.95
CANADA \$2.50

THE MAGAZINE FOR ELECTRONICS & COMPUTER ENTHUSIASTS

- **1986 ELECTRONICS PRODUCT PREVIEW**
- **HOW TO ADD STEREO SOUND TO TV SETS**



Canon's New 8-mm Camcorder (p. 16)

Full Plans to Build:

- **An Audio Step Generator**
- **A Versatile Printer Stand**
- **A Day/Night Safety Beacon**

Product Reviews:

- **Canon's New "Canovision" 8-mm Camcorder**
- **Oberon's "Omni-Reader" Optical Text Reader**
- **Tecmar's "MegaFunction" Board**

A Versatile Printer Stand (p. 50)



Magnavox's Videowriter Word Processor (p. 22)

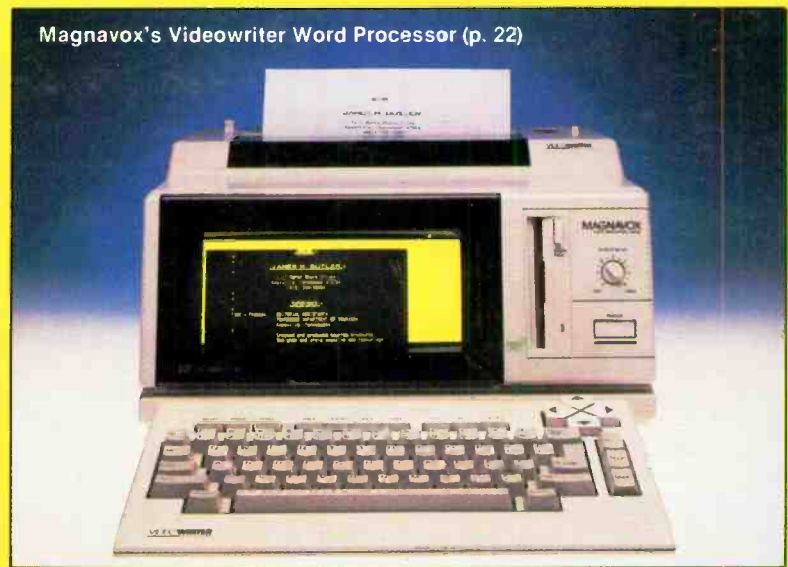

Also: ● Telephone Repairing ● Audio Amplifier Experiments ● New Electronic Memory and Microprocessor Chips ● Speed Reading & Framework II Software Reports ● The Top-Rated Shortwave Programs ● Latest Electronics/Computer News

Simpson Electric Company Introduces

mercer

The Ultimate in Low-Cost Test Equipment

At last! Here is your opportunity to take your pick from a new test equipment line that has all the features you need and more... and at a price that is unbelievably low. Here are six digital and two analog instruments... see them at your local distributor to make your choice.

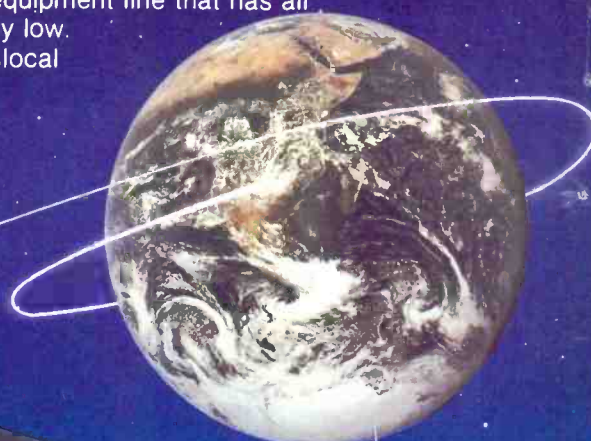

MODEL 9670
Digital capacitance tester covering 0.1 pF to 20,000 μ F
\$99⁰⁰

MODEL 9340
Pocket size, 3 1/2-digit DMM with 20 megohm range and 10 megohm input resistance
\$44⁰⁰

MODEL 9370
3 1/2-digit autoranging DMM with a memory mode and 0.5% basic DC accuracy
\$59⁰⁰

MODEL 9301
3 1/2-digit, hand-held DMM with 0.25% basic accuracy and 2,000-hour battery life
\$69⁰⁰

MODEL 9120
Analog VOM with 12 A DC range and output jack
\$39⁰⁰

MODEL 9401
4 1/2-digit full function, hand-held DMM with .05% accuracy and data hold
\$129⁰⁰

MODEL 9701
digi-clamp™ compact AC clamp-on volt-ohm-ammeter with data hold
\$69⁰⁰

MODEL 9101
Compact VOM with 27 ranges, including a 100 megohm range
\$29⁰⁰

mercer

ELECTRONICS

Division of Simpson Electric Company

859 Dundee Avenue, Elgin, IL 60120-3090
(312) 697-2265 • Telex 72-2416

CIRCLE NO. 166 ON FREE INFORMATION CARD

Mercer Electronics products reflect the design and quality standards established by Simpson Electric Company, an industry leader for over 50 years and known worldwide for its integrity and product excellence.

In Stock... Available Now! Stop in at your nearest distributor and see this new, complete line of Mercer test instruments. For the name of the MERCER distributor in your area, call (312) 697-2265, or send for our new line catalog.

Where's Your **ELECTRONICS** Career Headed?

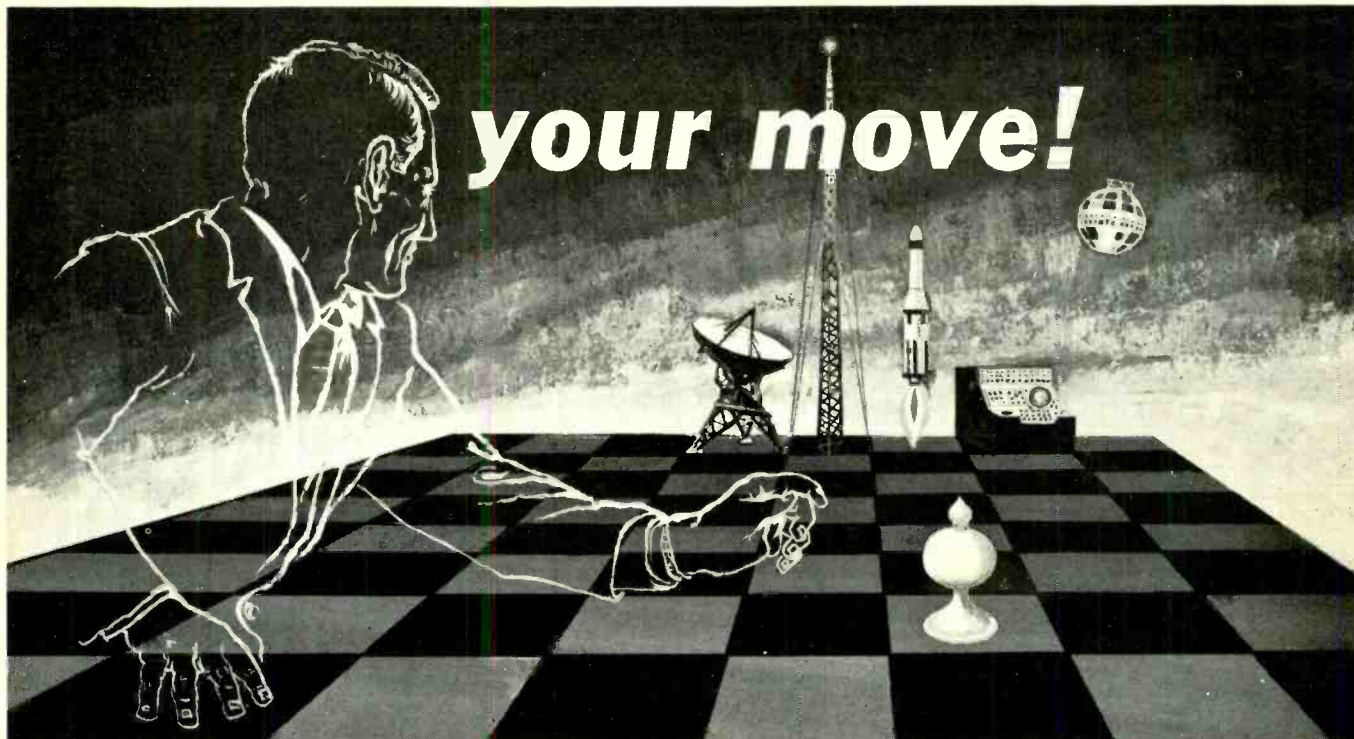

The Move You Make Today Can Shape Your Future

Yes it's your move. Whether on a chess board or in your career, you should plan each move carefully. In **electronics**, you can *move ahead* faster and further with a

B. S. DEGREE

Put professional knowledge and a COLLEGE DEGREE in your electronics career. Earn your degree through independent study at home, with Grantham College of Engineering. No commuting to class. Study at your own pace, while continuing your present job.

The accredited Grantham non-traditional degree program is intended for mature, fully employed workers who want to upgrade their careers . . . and who can successfully study electronics and supporting subjects through

INDEPENDENT STUDY, AT HOME

Free Details Available from:

Grantham College of Engineering
10570 Humbolt Street
Los Alamitos, California 90720

Independent Home Study Can Prepare You

Study materials, carefully written by the Grantham staff for independent study at home, are supplied by the College, and your technical questions related to those materials and the lesson tests are promptly answered by the Grantham teaching staff.

Recognition and Quality Assurance

Grantham College of Engineering is accredited by the Accrediting Commission of the National Home Study Council.

All lessons and other study materials, as well as communications between the college and students, are in the English language. However, we have students in many foreign countries; about 80% of our students live in the United States of America.

Grantham College of Engineering M-4-86
10570 Humbolt Street, Los Alamitos, CA 90720

Please mail me your free catalog which explains your B.S. Degree independent-study program.

Name _____ Age _____

Address _____

City _____ State _____ Zip _____

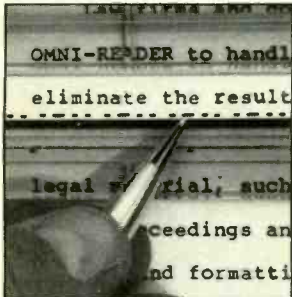

32



36

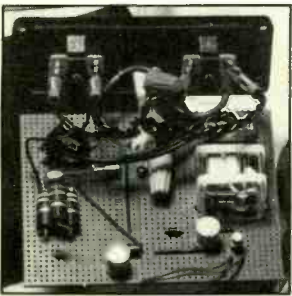

50

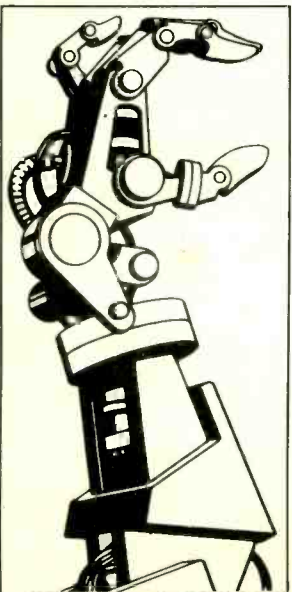

22

FEATURES

- 22 **New Electronic Products Coming Up**
A roundup of new video, audio and other consumer electronics. *By Joe Desposito*
- 32 **Reading By Computer**
Exploring optical data entry and an examination of Oberon's "Omni-Reader." *By John Richards*
- 36 **All About Telephones and How To Repair Them (Conclusion)**
A look at telephone repair. *By TJ Byers*
- 40 **An Audio Step Generator**
This project takes the tedium out of making frequency-response tests on audio equipment. *By Jack Cunkleman*
- 50 **A Versatile Printer Stand**
A printer-stand project with three paper "trays" and optical "smart" power and printer selectors. *By Bill Green*
- 56 **A Day/Night Safety Beacon**
Portable safety device can be seen by oncoming traffic day and night. *By Anthony J. Caristi*
- 60 **Add Stereo Sound to Your TV Receiver**
Ready any TV set to use a commercial stereo TV converter. *By Gary McClellan*

PRODUCT EVALUATIONS

- 16 **Canon's "Canonvision" Model VM-E1 8-mm Camcorder**
By Stan Prentiss
- 32 **Oberon's "Omni-Reader" Optical Character Recognizer**
By John Richards

COLUMNS

- 66 **Electronics Notebook**
Audio Amplifier Experiments. *By Forrest M. Mims III*
- 74 **Software Focus**
CBS's "MicroSpeed Read." *By Art Salsberg*
- 76 **Hardware Hacker**
Author answers readers' questions. *By Don Lancaster*
- 83 **PC Papers**
Ashton-Tate's Framework II, Tecmar's Mega-Function memory, RAM-disk and I/O board. *By Eric Grevstad*
- 86 **Communications**
Top Shortwave Programs. *By Glenn Hauser*

DEPARTMENTS

- 4 **Editorial**
By Art Salsberg
- 4 **Letters**
- 6 **Modern Electronics News**
- 12 **New Products**
- 73 **Books**
- 94 **Advertisers Index**

EDITORIAL STAFF

Art Salsberg
Editor-in-Chief
Alexander W. Burawa
Managing Editor
Dorothy Kehrwieler
Production Manager
Elizabeth Ryan
Art Director
Barbara Scully
Artist
Pat Le Blanc
Richard Kishanuk
Phototypographers
Hal Keith
Illustrator
Bruce Morgan
Photographer
Leonard Feldman, Eric Grevstad,
Glenn Hauser, Don Lancaster,
Forrest Mims III, Stan Prentiss,
Charles Rubenstein
Contributing Editors

BUSINESS STAFF

Richard A. Ross
Publisher
Art Salsberg
Associate Publisher
Dorothy Kehrwieler
General Manager
Arlene Caggiano
Accounting
Cheryl Chomicki
Subscriber Services

SALES OFFICES

Modern Electronics
76 North Broadway
Hicksville, NY 11801
(516) 681-2922

Midwest Advertising Representative
Market/Media Associates
1150 Wilmette Ave.
Wilmette, IL 60091
(312) 251-2541
Ted Rickard
Kevin Sullivan

Western Advertising Representative
JE Publishers Representatives
6855 Santa Monica Blvd., Suite 200
Los Angeles, CA 90038
(213) 467-2266
Jay Eisenberg, Director
San Francisco: (415) 864-3252
Denver: (303) 595-4331

Offices: 76 North Broadway, Hicksville, NY 11801. Telephone: (516) 681-2922. Modern Electronics (ISSN 0748-9889) is published monthly by Modern Electronics, Inc. Application to mail at second class rates pending at Hicksville, NY and other points. Subscription prices (payable in US Dollars only): Domestic - one year \$16.97, two years \$31.00, three years \$45.00; Canada/Mexico - one year \$19.00, two years \$35.00, three years \$51.00; Foreign - one year \$21.00, two years \$39.00, three years \$57.00. Foreign Air Mail - one year \$74.00, two years \$145.00, three years \$216.00.

Entire contents copyright 1986 by Modern Electronics, Inc. Modern Electronics or Modern Electronics, Inc. assumes no responsibility for unsolicited manuscripts. Allow six weeks for delivery of first issue and for change of address. Printed in the United States of America. Postmaster: Please send change of address notice to Modern Electronics, Inc., 76 North Broadway, Hicksville, NY 11801.

Radio Shack Parts Place™

START YOUR NEXT PROJECT AT THE SHACK®

Build With the Best! Manufacturer's First-Quality ICs

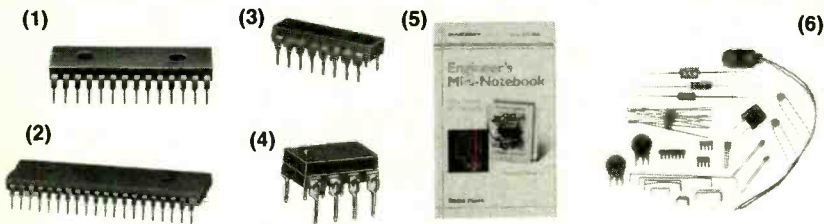

(1) **SPO256-AL2 Speech Synthesis IC.** This 28-pin MOS LSI device uses a stored program to produce natural sounding speech. With circuit examples and detailed data. Support parts are available through Radio Shack. #276-1784 **12.95**

(2) **CTS256-AL2 Text-to-Speech IC.** This 40-pin device translates standard ASCII characters into control data for the synthesizer above. Makes it a snap to add voice output to almost any computer or terminal. With data. #276-1786 **16.95**

(3) **4164 64K D-RAM.** Quality chip with 150 ns access. Upgrade your micro! #276-2506 . **3.95**

(4) **TLC555 CMOS Timer IC.** Super low-power version of standard 555. Ideal for battery-powered equipment. #276-1718 **1.39**

(5) **Timer IC Mini-Notebook.** By Forrest Mims III. Build 28 circuits! Large schematic diagrams help you learn to use the versatile 555 and 556 ICs. 32 pages. #276-5010 **99¢**

(6) **Timer Project Parts.** For above. Requires breadboard and 9V battery. #277-061 . . . **11.95**

Battery Guidebook

NEW! 1⁹⁹

Learn how batteries work, how to recharge and test them, and how to choose the best values. Also provides technical data on all Radio Shack ENERCELL batteries. 160 pages. #62-1396

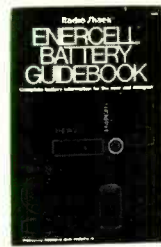

Heavy and Light-Duty Switches



(7) **Heavy-Duty DPDT.** Center off position. Rated 10 amps at 125 VAC. Screwdriver terminals. With on/off on label plate. Mounts in 7/16" dia. hole. #275-1533 **1.79**

(8) **3-Position DIP.** For digital/low-current use. Mounts in 16-pin DIP socket or PC board. #275-1301 . . . **1.69**

Communicate With Light!



Optical Fiber Cable. This 5-meter length of high-quality 1000-micron plastic cable is ideal for experiments. Design your own lightwave link. #276-228 **5.99**

Emitter/Detector Pair. Use to send analog or digital signals through fiber optic cable. No special tools needed. With data and sample circuits. #276-225 **4.99**

Two Alarming Values



Piezo Buzzer. Steady or pulsed output, depending on hookup to screwdriver terminals. 4 to 28 VDC. Output is 90 dB at 12 VDC, only 10 mA. Easily panel mounted in 1/16" dia. hole. #273-068 **6.95**

XC-5491 Tri-Color LED. Glows red on DC, green on reverse DC, yellow on AC. T-1 3/4 size. #276-035 . . . **1.29**

4000-Series CMOS ICs

■ Highest Quality
■ With Pin-Out, Specs

Low As **99¢**



Description	Type	Cat. No.	Each
Quad 2-Input NOR Gate	4001	276-2401	.99
Quad 2-Input NAND Gate	4011	276-2411	.99
Dual Type-D Flip Flop	4013	276-2413	1.19
Decade Counter/Divider	4017	276-2417	1.49
Inverting Hex Buffer	4049	276-2449	1.19
Quad Bilateral Switch	4066	276-2466	1.19

For Model Railroaders!

Mini Lamps. One red, one yellow, one green.

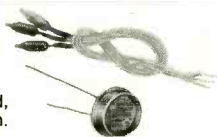

Volts	Cat. No.	Pkg. of 3
6	272-1098	69
12	272-1099	69

Cds Photoresistor. Rated 200 mW at 170 V, max. #276-116 . . . **1.29**

Enclosure and PC Board

Only **2⁹⁹**



Small enclosure, big value! 1 3/16 x 3 7/16 x 2 5/16" Rugged, yet easy-to-drill molded plastic. Includes board with 483 DIP-spaced, solder-ringed holes, two labels, complete hardware, snap-in rubber feet. #270-291

PC-Mount 3/4-Watt 15-Turn Pots

1⁴⁹ Each



For critical, fine-control, trimming. 10% tolerance.

Ohms	1000	10k	20k
Cat. No.	271-342	271-343	271-340

New "Hotline" Service!

Your Local Radio Shack Can Replace Almost Any IC or Semiconductor

Over 200,000 Substitutions!

No Minimum ■ No Postage Charge

If the semiconductor or IC you need is not part of our regular stock, we'll check our new in-store substitution guide and special-order a replacement from our warehouse. Your order will be sent ASAP to your local Radio Shack store and you'll be notified when it arrives. We also offer this convenient service on selected tubes, crystals, phonograph cartridges and styli.



Digital Multimeter with Autoranging

Just Select The Function And it Does The Rest!

Only **34⁹⁵**



This accurate, extra-durable Micronta® DVM features an easy-to-read LC display plus fuse and overload protection. Measures to 1000 volts DC, 750 volts AC, DC current to 2000 mills, resistance to 2 megs, and has a "diode-check" mode for semiconductor junctions. 4 7/8 x 2 13/16 x 1 1/4". With probes, manual and spare fuse. Requires 2 "AA" cells. #22-188

Prewired Car Clock Module

Special Purchase!

Only **4⁹⁵**



MA3003D-2. Detroit's goof, your gain! Fluorescent display with 1/4"-high digits is easy to read, night or day. Great for vehicles or stationary application—all you need is 12 volts DC. Approximately 1 3/8 x 2 1/8 x 1 1/2". #277-1021

Triple-Output DC Supply

Special Purchase!

Only **4⁹⁵**

Originally for Colecovision, it's ready to plug into AC and deliver +5 VDC to 900 mA, -5 VDC to 100 mA, and +12 VDC to 300 mA. UL listed. #277-1022



Over 1000 items in stock: Binding posts, Books, Breadboards, Buzzers, Capacitors, Chokes, Clips, Connectors, Fuses, Hardware, ICs, Jacks, Knobs, Lamps, Multitesters, PC Boards, Plugs, Rectifiers, Relays, Resistors, Switches, Tools, Transformers, Transistors, Wire, Zeners and more!

Radio Shack®

A DIVISION OF TANDY CORPORATION
Prices apply at participating Radio Shack stores and dealers

Free Famous hi-tech catalog



A very special guide to what the exciting world of computer and electronics kit-building can do for you.

The informative Heathkit Catalog shows you more than 450 exciting electronic products that will challenge, instruct, and entertain you. You'll find countless kits that you can build and enjoy, from computers and robots to color tv's and a variety of home products. And each is backed by our years of experience and our promise, "We won't let you fail."

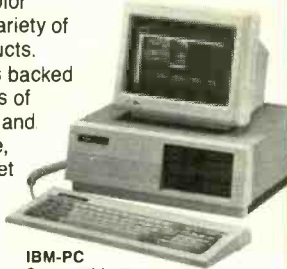

IBM-PC Compatible Expandable Computers



HERO® 2000 Educational Robot and Courseware

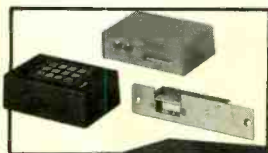

Precision Test Instruments

Electronic Keyless Doorlock



Amateur Radio Terminal Node Controller



Send NOW for your FREE Heathkit Catalog.

Send to: Heath Company, Dept 079-402
Benton Harbor, Michigan 49022

Name _____

Address _____

City _____ State _____ Zip _____

A subsidiary of Zenith Electronics Corporation CL-784R1

Heathkit
Health Company

EDITORIAL

Knowing Too Much

"You can never know too much," say lots of people. Nevertheless, there's a saturation point in gathering knowledge that limits all of us. One can't be "expert" in everything nowadays because information in each specialized field runs too deep.

In *Modern Electronics* we cover the breadth of electronics/computers with various degrees of depth. Readers can pick and choose their major activities from among them, keeping an eye on what's happening with lesser interests. At any given moment, one can then become greatly interested in another electronics/computer area, perhaps piqued by one of our articles or an advertisement, and switch equipment buying habits to a new special-interest attraction. ME's continual coverage in all areas readies readers for a switch to another major interest when the moment strikes, intensifying what one knows.

In some developed countries, people are purposely shut out from becoming involved in expanding high-tech knowhow outside their work place. Consequently, there are always intrepid people in these countries who dare to go underground with a forbidden activity. It might be certain books, video recorders, shortwave receivers, computers, etc.

On the latter, personal computers are just now making their debut in the Soviet Union with a \$1,250 model BK-0010. Frankly, I was surprised to learn this since the U.S.S.R. has steadfastly clamped

down on any possible spread or exchange of information that the government cannot control. This was cleared up by a recent *New York Times* (January 26) article reporting that very few of the new personal computers were available for sale. Furthermore, printers were not available at all and software was limited. Moreover, the computer was judged to be for professional programmers. Topping this, Soviet telephone lines are filled with too much static to allow reliable data communications with this medium.

In all, then, the U.S.S.R. is preventing its young people from gaining computer literacy. I wonder if the Russian people will go underground with black-market computers much as they did with VCRs and pre-recorded tapes, causing the government to loosen its restrictive policy in this area. Foreign broadcasts are still jammed, though; direct-telephone dialing from the U.S. was stopped a few years ago; and only authorized persons can use a photocopy machine in the U.S.S.R.

So here is a case where government edict makes sure that one cannot know too much. Take a moment and think about how fortunate we are that such restrictions are not imposed on us here in the United States.

Art Salsberg

LETTERS

The Old Team

•To see the "old team" running "Modern Electronics" was a real pleasure, as I was a subscriber to "Popular Electronics" for many years.

David Botto
Dorset, England

Experimenter's Project Works

•I very much liked the article in your July '85 issue called A Multi-Function Two - Transistor oscillator ["Electronics Notebook" column]. I have tried all the circuits on a breadboard and they all function well. The author, Forrest M. Mims, mentions other uses. I hope in the future to see these circuits published.

I especially like the clarity of your material and the paper it's printed on.

Wallace G. Kennedy
Ozone Park, NY

CoCo Errata

•My "CoCo Testlab" article in the February issue looks great! However, in Fig. 1, IC1 should be 6821 (the correct number is given in the Parts List)—not the 6812 shown. I note also that the pin holes in all IC pads in Fig. 2 are filled in.

One final note: Kit No. ME-1 includes all parts, pc board, software on tape and instruction manual.

Jim Barbarello
It's almost impossible to "hold" such holes in mass printing.—Ed.

NEW! Lower Price Scanners

Communications Electronics™, the world's largest distributor of radio scanners, introduces new lower prices to celebrate our 15th anniversary.

Regency® MX7000-EA

List price \$699.95/CE price \$399.95/SPECIAL
10-Band, 20 Channel • Crystalless • AC/DC
Frequency range: 25-550 MHz. continuous coverage and 800 MHz. to 1.3 GHz. continuous coverage. The Regency MX7000 scanner lets you monitor military, F.B.I., Space Satellites, Police and Fire Departments, Drug Enforcement Agencies, Defense Department, Aeronautical AM band, Aero Navigation Band, Fish & Game, Immigration, Paramedics, Amateur Radio, Justice Department, State Department, plus thousands of other radio frequencies most scanners can't pick up. The Regency MX7000 is the perfect scanner for intelligence agencies that need to monitor the new 800 MHz. cellular telephone band. The MX7000, now at a special price from CE.

Regency® Z60-EA

List price \$299.95/CE price \$179.95/SPECIAL
8-Band, 60 Channel • No-crystal scanner
Bands: 30-50, 88-108, 118-136, 144-174, 440-512 MHz. The Regency Z60 covers all the public service bands plus aircraft and FM music for a total of eight bands. The Z60 also features an alarm clock and priority control as well as AC/DC operation. Order today.

Regency® Z45-EA

List price \$259.95/CE price \$159.95/SPECIAL
7-Band, 45 Channel • No-crystal scanner
Bands: 30-50, 118-136, 144-174, 440-512 MHz. The Regency Z45 is very similar to the Z60 model listed above however it does not have the commercial FM broadcast band. The Z45, now at a special price from Communications Electronics.

Regency® RH250B-EA

List price \$613.00/CE price \$329.95/SPECIAL
10 Channel • 25 Watt Transceiver • Priority
The Regency RH250B is a ten-channel VHF land mobile transceiver designed to cover any frequency between 150 to 162 MHz. Since this radio is synthesized, no expensive crystals are needed to store up to ten frequencies without battery backup. All radios come with CTCSS tone and scanning capabilities. A monitor and night/day switch is also standard. This transceiver even has a priority function. The RH250 makes an ideal radio for any police or fire department volunteer because of its low cost and high performance. A UHF version of the same radio called the RU150B covers 450-482 MHz. but the cost is \$449.95. To get technician programming instructions, order a service manual from CE with your radio system.

NEW! Bearcat® 50XL-EA

List price \$199.95/CE price \$114.95/SPECIAL
10-Band, 10 Channel • Handheld scanner
Bands: 29.7-54, 136-174, 406-512 MHz. The Uniden Bearcat 50XL is an economical, hand-held scanner with 10 channels covering ten frequency bands. It features a keyboard lock switch to prevent accidental entry and more. Also order part # BP50 which is a rechargeable battery pack for \$14.95, a plug-in wall charger, part # AD100 for \$14.95, a carrying case part # VC001 for \$14.95 and also order optional cigarette lighter cable part # PS001 for \$14.95.



NEW! Regency® XL156-EA

List price \$239.95/CE price \$129.95/SPECIAL
6-Band, 10 Channel • No-crystal Scanner
Search • Lockout • Priority • AC/DC
Bands: 30-50, 144-174, 440-512 MHz. Cover your choice of over 15,000 frequencies on 10 channels at the touch of your finger. Display messages. External speaker jack. Telescoping antenna. External antenna jack. AC/DC.

NEW! Regency® R1060-EA

List price \$149.95/CE price \$92.95/SPECIAL
6-Band, 10 Channel • Crystalless • AC only
Bands: 30-50, 144-174, 440-512 MHz. Now you can enjoy computerized scanner versatility at a price that's less than some crystal units. The Regency R1060 lets you in on all the action of police, fire, weather, and emergency calls. You'll even hear mobile telephones.

Bearcat® DX1000-EA

List price \$649.95/CE price \$349.95/SPECIAL
Frequency range 10 KHz. to 30 MHz. The Bearcat DX1000 shortwave radio makes tuning in London as easy as dialing a phone. It features PLL synthesized accuracy, two time zone 24-hour digital quartz clock and a built-in timer to wake you to your favorite shortwave station. It can be programmed to activate peripheral equipment like a tape recorder to record up to five different broadcasts, any frequency, any mode, while you are asleep or at work. It will receive AM, LSB, USB, CW and FM broadcasts.

There's never been an easier way to hear what the world has to say. With the Bearcat DX1000 shortwave receiver, you now have direct access to the world.

NEW! Regency® HX1200-EA

List price \$369.95/CE price \$214.95/SPECIAL
8-Band, 45 Channel • No Crystal scanner
Search • Lockout • Priority • Scan Delay
Sidelit liquid crystal display • EAROM Memory
New Direct Channel Access Feature
Bands: 30-50, 118-136, 144-174, 406-420, 440-512 MHz. The new handheld Regency HX1200 scanner is fully keyboard programmable for the ultimate in versatility. You can scan up to 45 channels at the same time including the AM aircraft band. The LCD display is even sidelit for night use. Order MA-256-EA rapid charge drop-in battery charger for \$84.95 plus \$3.00 shipping/handling. Includes wall charger, carrying case, belt clip, flexible antenna and nicad battery.

NEW! Bearcat® 100XL-EA

List price \$349.95/CE price \$203.95/SPECIAL
9-Band, 16 Channel • Priority • Scan Delay
Search • Limit • Hold • Lockout • AC/DC
Frequency range: 30-50, 118-174, 406-512 MHz. The world's first no-crystal handheld scanner now has a LCD channel display with backlight for low light use and aircraft band coverage at the same low price. Size is 1 3/4" x 7 1/2" x 2 1/2". The Bearcat 100XL has wide frequency coverage that includes all public service bands (Low, High, UHF and "T" bands), the AM aircraft band, the 2-meter and 70 cm. amateur bands, plus military and federal government frequencies. Wow...what a scanner! Included in our low CE price is a sturdy carrying case, earphone, battery charger/AC adapter, six AA Ni-cad batteries and flexible antenna. Order your scanner now.

Bearcat® 210XW-EA

List price \$339.95/CE price \$209.95/SPECIAL
8-Band, 20 Channel • No-crystal scanner
Automatic Weather • Search/Scan • AC/DC
Frequency range: 30-50, 136-174, 406-512 MHz. The new Bearcat 210XW is an advanced third generation scanner with great performance at a low CE price.

NEW! Bearcat® 145XL-EA

List price \$179.95/CE price \$102.95/SPECIAL
10 Band, 16 channel • AC/DC • Instant Weather
Frequency range: 29-54, 136-174, 420-512 MHz. The Bearcat 145XL makes a great first scanner. Its low cost and high performance lets you hear all the action with the touch of a key. Order your scanner from CE today.

TEST ANY SCANNER

Test any scanner purchased from Communications Electronics™ for 31 days before you decide to keep it. If for any reason you are not completely satisfied, return it in original condition with all parts in 31 days, for a prompt refund (less shipping/handling charges and rebate credits).

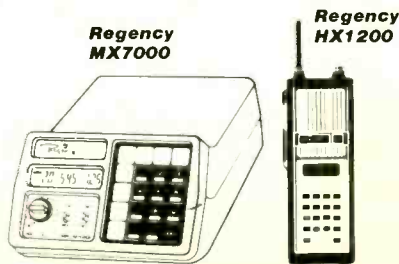

CIRCLE 31 ON FREE INFORMATION CARD

NEW! Bearcat® 800XLT-EA

List price \$499.95/CE price \$317.95
12-Band, 40 Channel • No-crystal scanner
Priority control • Search/Scan • AC/DC
Bands: 29-54, 118-174, 406-512, 806-912 MHz. The Uniden 800XLT receives 40 channels in two banks. Scans 15 channels per second. Size 9 1/4" x 4 1/2" x 1 1/2"

OTHER RADIOS AND ACCESSORIES

Panasonic RF-2600-EA Shortwave receiver \$179.95
RD95-EA Uniden Remote mount Radar Detector \$128.95
RD55-EA Uniden Visor mount Radar Detector \$98.95
RD9-EA Uniden "Passport" size Radar Detector \$239.95
BC 210XW-EA Bearcat 20 channel scanner SALE \$209.95
BC-WA-EA Bearcat Weather Alert* \$49.95
DX1000-EA Bearcat shortwave receiver SALE \$349.95
PC22-EA Uniden remote mount CB transceiver \$99.95
PC55-EA Uniden mobile mount CB transceiver \$59.95
R1060-EA Regency 10 channel scanner SALE \$92.95
MX3000-EA Regency 30 channel scanner \$198.95
XL156-EA Regency 10 channel scanner SALE \$129.95
UC102-EA Regency VHF 2 ch. 1 Watt transceiver \$124.95
RH250B-EA Regency 10 ch. 25 Watt VHF trans. \$329.95
RH600B-EA Regency 10 ch. 60 Watt VHF trans. \$454.95
RU150B-EA Regency 10 channel UHF transceiver \$449.95
RP410-EA 10 ch. handheld no-crystal trans. \$399.95
LC10-EA Carrying case for RP410 transceiver \$34.95
MA181-EA Ni-cad battery pack for RP410 trans. \$34.95
P1405-EA Regency 5 amp regulated power supply \$69.95
P1412-EA Regency 12 amp reg. power supply \$164.95
BC10-EA Battery charger for Regency RP410 \$84.95
MA256-EA Drop-in charger for HX1000 & HX1200 \$84.95
MA257-EA Cigarette lighter cord for HX1200 \$19.95
MA917-EA Ni-Cad battery pack for HX1200 \$34.95
EC10-EA Programming tool for Regency RP410 \$24.95
SMRH250-EA Service man. for Regency RH250 \$24.95
SMRU150-EA Service man. for Regency RU150 \$24.95
SMRPH410-EA Service man. for Regency RP410 \$24.95
SMMX7000-EA Svc. man. for MX7000 & MX5000 \$19.95
SMMX3000-EA Svc. man. for Regency MX3000 \$19.95
B-4-EA 1.2 V AAA Ni-Cad batteries (set of four) \$9.95
FB-E EA Frequency Directory for Eastern U.S.A. \$12.95
FB-W EA Frequency Directory for Western U.S.A. \$12.95
TSG-EA "Top Secret" Registry of U.S. Govt. Reg. \$14.95
TIC-EA Techniques for Intercepting Comm. \$14.95
RRF-EA Railroad frequency directory \$10.95
CIE-EA Covert/Intelligent, Elect. Eavesdropping \$14.95
A60-EA Magnet mount mobile scanner antenna \$35.00
A70-EA Base station scanner antenna \$35.00
USAMM-EA Mag mount VHF/UHF ant. w/ 12' cable \$39.95
USAKEA 3/4" hole mount VHF/UHF ant. w/ 17' cable \$35.00
USATLM-EA Truck mount VHF/UHF antenna \$35.00
Add \$3.00 shipping for all accessories ordered at the same time.	
Add \$12.00 shipping per shortwave receiver.	
Add \$7.00 shipping per scanner and \$3.00 per antenna.	

BUY WITH CONFIDENCE

To get the fastest delivery from CE of any scanner, send or phone your order directly to our Scanner Distribution Center™. Michigan residents please add 4% sales tax or supply your tax I.D. number. Written purchase orders are accepted from approved government agencies and most well rated firms at a 10% surcharge for net 10 billing. All sales are subject to availability, acceptance and verification. All sales on accessories are final. Prices, terms and specifications are subject to change without notice. All prices are in U.S. dollars. Out of stock items will be placed on backorder automatically unless CE is instructed differently. A \$5.00 additional handling fee will be charged for all orders with a merchandise total under \$50.00. Shipments are F.O.B. Ann Arbor, Michigan. No COD's. Most products that we sell have a manufacturer's warranty. Free copies of warranties on these products are available prior to purchase by writing to CE. Non-certified checks require bank clearance.

Mail orders to: Communications Electronics™, Box 1045, Ann Arbor, Michigan 48106 U.S.A. Add \$7.00 per scanner for U.P.S. ground shipping and handling in the continental U.S.A. For Canada, Puerto Rico, Hawaii, Alaska, or APO/FPO delivery, shipping charges are three times continental U.S. rates. If you have a Visa or Master Card, you may call and place a credit card order. Order toll-free in the U.S. Dial 800-USA-SCAN. In Canada, order toll-free by calling 800-221-3475. Telex CE anytime, dial 810-223-2422. If you are outside the U.S. or in Michigan dial 313-973-8888. Order today.

Scanner Distribution Center™ and CE logos are trademarks of Communications Electronics Inc.

* Bearcat is a registered trademark of Uniden Corporation.
† Regency is a registered trademark of Regency Electronics Inc.

AD #040186-EA
Copyright © 1986 Communications Electronics Inc.

For credit card orders call
1-800-USA-SCAN

COMMUNICATIONS ELECTRONICS INC.

Consumer Products Division
P.O. Box 1045 □ Ann Arbor, Michigan 48106-1045 U.S.A.
Call 800-USA-SCAN or outside U.S.A. 313-973-8888

COMPUTER MAJORS DOWN. Along with decreased computer sales, fewer college freshmen chose computers as a major in fall 1985 than in the past two years. According to a survey by the American Council on Education and the University of California/Los Angeles, only 4.4% of new freshmen chose computer careers in contrast to 6.1% in 1984 and 8.8% in 1983. That's a 50% drop. Engineering, too, has been hit, though not as hard. Engineering registrants dropped to 10% of entering freshmen as compared to 10.4% in the previous year. Business and teaching were the gainers.

TWO-VCR FAMILIES. Seventeen percent of all videocassette recorder purchases in 1985 were made by current owners of VCRs, according to a market survey made by RCA Consumer Electronics. The company estimates that more than 25% of new VCR sales in 1986 are expected to be made by second-time VCR buyers. Research indicates that the second VCRs are being bought with innovative features such as extended programmability, stop action, audio dubbing, hi-fi stereo sound, etc.

DEMO DISK PROM. Maxell Corp. has launched a floppy-disk promotion campaign that includes a trial Computerized World Atlas software program with the purchase of a 10-pack of Maxell MD-2 5¼" diskettes. The bonus program displays a 3D representation of the globe that can be rotated and enlarged or decreased. Typing in the name of a city provides information on more than 2,500 cities, such as population, distances between cities, and geographic location. There's a catch, though. The program can be loaded and used for only three 40-minute trials before it locks to prevent further use. It will cost the owner \$69.95 to get the unlocking code. Should the user not wish to take this route, he still has an eleventh disk free. Maxell also launched another 10-pack promotion with Citibank. Here, a free demonstration disk, Citibank's "Direct Access" program for personal computer banking service, is packaged. Along with the free disk, Citibank offers purchasers a free trial period for its use.

1985: A VIDEO BANNER YEAR. VCR sales in 1985 topped 11.8-million units, jumping 55% over 1984's 7.6-million units sold to dealers, according to the EIA's Consumer Electronics Group. VCRs are now said to be in 30% of American households. Color TV sales, too, set a record with almost 17-million sets sold to dealers, beating the 16.1-million figure posted in 1984. Projection TV sales rose 36.1% to 265,645 units in 1985.

HI-TECH HOTEL CHECKOUT. Don't you hate waiting on a checkout line at a hotel? The Sheraton Hotel people evidently empathize with their guests. They've installed Express Center video consoles in their hotels in San Diego, Anaheim, Miami, Toronto, and Washington, DC to change all this. Guests simply insert their credit card into the machine, touch the appropriate screen prompt, and they receive an itemized receipt in less than 30 seconds. In the Sheraton Park Central in Dallas, guests can use a keyboard attached to the TV set in their room. It takes only a few keystrokes to review one's itemized hotel statement and arrange billing on a credit card.

Only NRI gives you professional hands-on training and equipment to prepare you for today's high-tech video electronics servicing careers.



**Become One of America's Most Sought-After Technicians . . .
Put Your Talents and Spare Time To Work for You in the
"Explosive-Growth" World of Home Entertainment Electronics**

Train in state-of-the-art video/audio servicing and become a fully qualified professional the uniquely successful NRI way. It's hands-on training, at home . . . designed around the latest state-of-the-art electronic equipment you build as part of your training. You start from scratch and "discover by doing." You conduct key experiments . . .

perform vital tests . . . build your own systems . . . and do it all at the pace that suits you best.

There's no stopping the incredible boom in consumer electronics. Soaring sales, new and improved products, entirely new technologies have opened up new opportunities for the trained technician as never before.

The \$25 billion consumer electronics industry is creating a whole new servicing and repair market at home. This year, TV sales alone are expected to hit 16.2 million units. That's \$5.5 billion dollars. Every day, sales of home VCRs, a product barely conceived of ten years ago, reach 20,000 units. Every day!

And the revolution has spread to the business sector as tens of thousands of companies are purchasing expensive high-tech video equipment used to train their employees and store important company data.

The High-Tech Revolution Is Just Starting

Already, disc players can handle both audio CDs as well as laser video discs. And coming are machines that will accommodate laser computer discs. Camcorders are becoming smaller, lighter and more versatile, 8mm video cassettes will produce high resolution pictures. Soon, our TVs will become interactive computer terminals, giving us entertainment, information and communications in one sophisticated unit.

Join the Future or Be Left Behind

Can you see the opportunity? The servicing and repair market that's there already . . . the enormous need created by the millions upon millions of electronic devices yet to come. If you're looking for a high-potential career in a clean, respected industry . . . if you'd like to get started in a field that's still wide open for the independent business person . . . even if you'd like to find a way to make extra money "moonlighting," now's the time to look into NRI at-home training.

Start Right and There'll Be No Stopping You!

NRI training in Video/Audio Servicing is the perfect way for you to profit from the era of consumer electronics. You study at home in your spare time at your own pace. No classroom pressures, no night school grind.

Even if you've never had electronics training, NRI prepares you properly with a thorough grounding in the fundamentals . . . a

foundation that you build on to achieve advanced electronic skills. With this kind of understanding and practical bench experience built into NRI's exclusive training methods, you are on your way to take advantage of the new opportunities that are opening up every day.

Totally Integrated Hands-On Training

The secret of NRI's training success lies in the unique way multimedia instructions are fully integrated with the equipment you use. NRI's Action Audio and Video cassettes combine with brilliantly illustrated and well thought out lesson materials to give you a thoroughly stimulating and productive learning experience.

Since NRI training is built around learning by doing, right from the start you conduct important experiments and tests with your professional digital multimeter.

You assemble the remarkable



Only NRI trains you with Action Video tapes for step-by-step professional servicing skills reinforcement. You'll watch complicated troubleshooting techniques come to life!

Your NRI Training Has Another Special Element

Also built into your NRI training is the enormous experience of our development specialists and instructors. Their long-proven training skills and personal guidance come to you on a one-to-one basis. They are always available for consultation and help.

Step Into the Future Today

The richest reward you gain from your NRI Video/Audio training is a firm grip on the future. Your knowledge and know-how provide you with the soundest possible foundation for further learning and growth with the industry.

Send For Free Catalog

But now is the time to act. Return the post-paid card to us today. You will receive our 100-page catalog free. It's filled with all the details you'll want to know about our training methods and materials and our more than 70 years of successful innovation in at-home, hands-on career training. (If someone has beaten you to the card, write to us at the address below.)



Only NRI's video training includes a state-of-the-art TV you build, the latest VCR, professional test equipment, and NRI Action Video tapes. All yours to keep as part of your training.

demonstrations and experiments in the process. You build your own 25"

Heath/Zenith color TV and train with the latest model front-loading VCR, also included as part of your course.

NRI has purposely designed your training around equipment that has the same high-tech circuitry you'll encounter in commercial equipment. That means your training is real-world training. And *that's* unique.

NRI Schools

McGraw-Hill Continuing Education Center
3939 Wisconsin Avenue, NW
Washington, DC 20016



For more information on products described, please circle the appropriate number on the Free Information Card bound into this issue or write to the manufacturer.

IC Tester/Logic Monitor

A compact, hand-held combination comparator tester for most 5400 and 7400 series TTL ICs and logic monitor for 5-volt devices in 14-, 16- and 18-pin DIPs has been introduced by B&K-Precision. The Model 550 instrument tests standard TTL, Schottky (S), low-power Schottky (LS), advanced Schottky (AS), advanced low-power Schottky (ALS), high-speed (H) and fast (F) families. Tests are performed in-circuit.



The instrument compares the logic states of an IC under test with those of a known-good reference IC. If all logic states are equal, a "Good" indicator lights; if not, a LED lights for each pin where logic states are not equal. Switches are provided for standard configuration ground and V+ on 14-, 16-, 18- and 20-pin TTL ICs and for individual pin selection for nonstandard configurations.

When used as a logic monitor, the 550 indicates the logic state of each pin. This function continuously monitors each pin to show both changing and constant logic states. \$395 includes 20- and 16-pin IC clips, table of testable devices and instruction manual.

CIRCLE 36 ON FREE INFORMATION CARD



Multi-Play CD Player

Pioneer Electronics' new Model PD-M6(BK) is said to be the world's first multi-play Compact Disc player for home use. The CD changer's six-disc magazine loads via a slot in the front panel. An internal mechanism then pulls individual disk-bearing trays into play position. Surprisingly, the PD-M6 is only about the same size as a typical single-disc player.

Front-panel and wireless remote controller keys access an array of play options and directly accesses any selection in the magazine. A 32-step memory allows the player to

repeat a full programmed sequence, one track, just one or all six discs. Alternatively, the player's microprocessor can randomly choose selections to be played.

Updates on disc and track numbers, elapsed time of track being played and total playing time on a disc appear in the player's fluorescent display panel. The display is also used to check programming and to show selections remaining during programmed play. \$499.95, includes remote controller, six-disc magazine and tray for single-disc play.

CIRCLE 37 ON FREE INFORMATION CARD

Movable Satellite TV Antenna Mount

Stoll Corp.'s (Sidney, OH) new SpaceMate AZ-EL Patio Mount does not require permanent installation and can easily be moved from

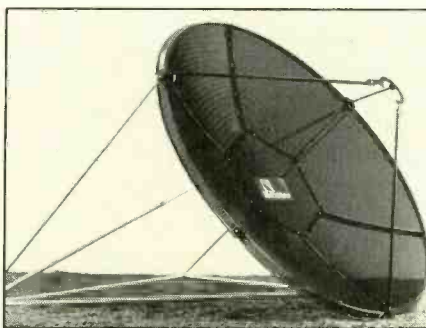

one location to another. It is designed to accommodate the company's SpaceMate 6-ft perforated aluminum paraboloid antenna. Supplied with detailed do-it-yourself assembly and satellite-aiming instructions, the

7-lb. unit eliminates the need for professional help. All tubular aluminum construction and steel hardware are claimed to make the Patio Mount durable enough to withstand any environmental elements.

CIRCLE 38 ON FREE INFORMATION CARD

Manual Desoldering Tools

Now available from A.P.E. Corp. is a complete line of handpumps for



manual desoldering. The pumps are equipped with antistatic tips to protect static-sensitive ICs and other components, while the pump mechanism is designed to minimize recoil to protect delicate circuitry from mechanical damage. There are five models in the line: DP-1 features all-metal construction and an antistatic tip; DP-2 is antistatic and conductive with conductive tip; DP-3 is a large-capacity plastic tool; DP-4 is spring actuated on the return and is all plastic; and DP-5 is spring actuated, conductive and antistatic with an antistatic tip. Less than \$13.

CIRCLE 39 ON FREE INFORMATION CARD

High-Performance X/K-Band Radar Detector

Controlonics' "Spectrum 2" triple-conversion superhet X- and K-band radar detector features different audible and visible indicators to inform you of the band detected, as well as single-button control.

A single-digit numeric display in-



dicates signal strength and brightens and dims with changes in light. Its decimal point tells whether a signal is on X (off) or K (flashing) band. Its audible alarm generates different tones for the X and K bands. A Whistler's Filter Mode minimizes triggering by intrusion alarms, and a variable filter sets triggering threshold as needed. Mute Mode silences the audible alarm near microwave transmissions and automatically re-

stores normal operation when you leave the area. Dark Mode turns off the display completely, without affecting the audible alarm, for discreet nighttime use.

"Spectrum 2" measures only 4.874" x 2.375" x 1.18". It comes with power cords and mounting hardware. \$329.95.

CIRCLE 40 ON FREE INFORMATION CARD

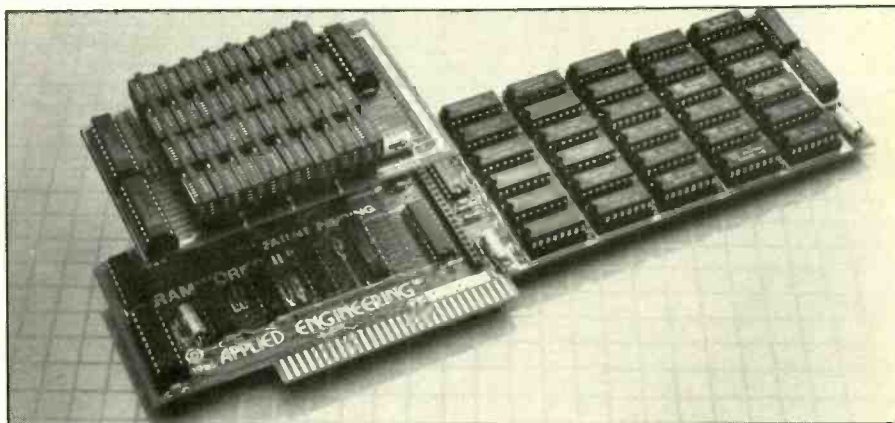

3M Memory Expansion Card

Need more memory for your Apple IIe? If so, you can add 3M bytes of additional RAM to your computer with a Ramworks II board from Applied Engineering. A piggyback board that is less than half the size of the 1M-byte Ramworks II main board holds an additional 2M bytes of memory storage capability, using 64 256K dynamic RAM chips mounted in small in-line packages. In addi-

tion to the main user RAM storage space, Ramworks II provides a built-in 64K printer buffer that frees your computer for other uses as a long document is being printed.

When plugged into an Apple IIe, the Ramworks II system produces an on-screen desktop message that reads: "2,277K avail." for users of the Appleworks program. \$1699 for full 3M; \$389 for 1M Ramworks II without piggyback board.

CIRCLE 41 ON FREE INFORMATION CARD

Compact Video Battery

A powerful, compact rechargeable nickel-cadmium battery pack from RCA offers 12-volt video equipment users longer operating time than is possible from the built-in battery. The new Model AVO20 Portable Power Pack measures 6.75" x 5" x 1.25" (about the size of a paperback book) and weighs only 1.75 lb., making it small enough to fit in a coat pocket. It can alternatively be strung from a shoulder via its carrying strap or be hung from a belt via its retractable clip.

A warning LED lights when the battery's power is getting low. Recharge to full capacity is then ac-



complished overnight. A self-resetting circuit breaker is built in to pro-

NEW PRODUCTS...

vide overload protection, so there is no fuse to replace. Finally, a universal connector allows the power pack to be used with any 12-volt dc product for which the manufacturer makes available an optional dc power cable, including TV receivers, VCRs, video cameras, camcorders and computers. \$114.95.

CIRCLE 47 ON FREE INFORMATION CARD

Dual Power Supply

Two fully independent power supplies with separate digital numeric panel meters are featured in VIZ Test Equipment's new Model WP-707A dual dc power supply. Each meter can be switched to monitor both the output voltage and current of either supply simultaneously or indepen-



dently. Each supply has its own set of controls (including circuit-breaker resets) and output connectors.

Maximum output from each supply is 25 volts dc. However, the two outputs can be connected in series to provide a summed output of up to 50 volts dc at up to 2 amperes.

CIRCLE 43 ON FREE INFORMATION CARD

Speech Synthesizer For C-64

A speech synthesizer that can automatically speak text as it is entered and spell words on command is now available for the Commodore 64 computer from Votrax, Inc. Votalker C-64's capabilities include a screen echo that allows words, numbers, punctuation and other symbols to be spoken as they are printed on the screen. Equipped with an SC-01A speech chip, the unit is said to have an unlimited vocabulary. It has a

SPEAK command that can be used with numbers, phrases and complex expressions, and pitch, volume and



rate controls to create natural-sounding speech. A MODE command offers three types of text vocalization: "conversation" reads text in a natural manner with appropriate pauses at punctuation marks; "verbatim" reads text and pronounces symbols; and "character" spells each word and pronounces numbers and symbols. Votalker C-64 is fast and easy to use because there is no software to load. All programs and enhancements are in ROM and are accessed with a single key. \$99.95.

CIRCLE 44 ON FREE INFORMATION CARD

Portable Micro-Disk Drive

Portability is the main feature of the new battery-powered Tandy 200/



Model 100 disk drive that measures only 6 $\frac{1}{8}$ "W \times 4 $\frac{3}{16}$ "D \times 2"H and weighs a mere 1 $\frac{3}{4}$ lbs. The drive can store 100K of data on a 3 $\frac{1}{2}$ " diskette. Included operating software on diskette lists the files on the disk and

provides format, save, load and other functions. Data transfer is at 19,200 baud.

The drive will not initiate a new function if the battery is low, but it will finish the job in progress when a battery-low condition is sensed. A battery warning indicator comes on when the battery's charge gets low, and a separate indicator lights when the disk is being accessed. Four AA cells or an optional ac adapter are required for operation. You initialize the drive by typing a simple three-line BASIC program.

CIRCLE 45 ON FREE INFORMATION CARD

Desoldering Braid

Philips ECG is now marketing a line of Swiftwick desoldering braid in 5- and 25-ft.-length spools. It is available in the five most popular widths, ranging from 0.03" for fine to 0.13"



for heavy desoldering jobs. The spool labels are color coded for easy identification of each size.

Swiftwick is a sensitive copper braid that is produced through a patented vacuumization process that yields a high-speed reaction wick that sucks up solder safely and quickly.

CIRCLE 46 ON FREE INFORMATION CARD

COMMODORE 64 COMPUTER

(Order Now)

\$ 139⁹⁵

- C128 Disks 79¢ ea.*
- Paperback Writer 64 \$39.95
- 10" Comstar 10X Printer \$148.00
- 13" Color Monitor \$159.95

CALL BEFORE YOU ORDER

COMMODORE 64 COMPUTER \$139.95

You pay only \$139.95 when you order the powerful 84K COMMODORE 64 COMPUTER! LESS the value of the SPECIAL SOFTWARE DISCOUNT COUPON we pack with your computer that allows you to SAVE OVER \$250 off software sale prices!! With only \$100 of savings applied, your net computer cost is \$39.95!!

* C128 DOUBLE SIDED DISKS 79¢ EA.

Get these 5 1/4" Double Sided Floppy Disks specially designed for the Commodore 128 Computer (1571 Disk Drive). 100% Certified. **Lifetime Warranty.** Automatic Lint Cleaning Liner included. 1 Box of 10 - \$9.90 (99¢ ea.), 5 Boxes of 10 - \$44.50 (89¢ ea.), 10 Boxes of 10 - \$79.00 (79¢ ea.).

13" COLOR MONITOR \$159.95

You pay only \$159.95 when you order this 13" COLOR MONITOR. LESS the value of the SPECIAL SOFTWARE DISCOUNT COUPON we pack with your monitor that allows you to save over \$250 off software sale prices!! With only \$100 of savings applied, your net color monitor cost is only \$59.95. (16 Colors).

Premium Quality 120-140 CPS Comstar 10X Printer \$148.00

The COMSTAR 10X gives you a 10" carriage, 120-140 CPS, 9 x 9 dot matrix with double strike capability for 18 x 18 dot matrix (near letter quality), high resolution bit image (120 x 144 dot matrix), underlining, back spacing, left and right margin setting, true lower decenders with super and subscripts, prints standard, italic, block graphics and special characters. It gives you print quality and features found on printers costing twice as much!! (Centronics Parallel Interface) List \$399.00 **Sale \$148.00.**

4 SLOT EXPANDER & 80 COLUMN BOARD \$49.95

Now you program 80 COLUMNS on the screen at one time! Converts your Commodore 64 to 80 COLUMNS when you plug in the 80 COLUMN EXPANSION BOARD!! PLUS 4 slot expander! **Limited Quantities Sale \$49.95. Coupon \$39.95.**

80 COLUMNS IN COLOR

PAPERBACK WRITER 64 WORD PROCESSOR \$39.95

This PAPERBACK WRITER 64 WORD PROCESSOR is the finest available for the COMMODORE 64 computer! The ULTIMATE FOR PROFESSIONAL Word Processing, DISPLAYS 40 or 80 COLUMNS IN COLOR or black and white! Simple to operate, powerful text editing, complete cursor and insert/delete key controls line and paragraph insertion, automatic deletion, centering, margin settings and output to all printers! List \$99.00. **SALE \$39.95. Coupon \$29.95.**

14" Hi-Res RGB Monitor

Plus Separated Composite Video

Perfect for 80 column use on the C128 plus includes green screen option and all controls accessed from the front of the monitor.

SALE \$259⁹⁵

Plus \$14.50 S&H

C128 COMMODORE COMPUTER

(Order Now)

* \$229⁰⁵

(SEE BELOW)

With \$59.95 Timeworks Wordwriter Wordprocessor savings applied

- 340K 1571 Disk Drive \$259.00
- Voice Synthesizer \$39.95
- 12" Amber Monitor \$79.95

PRICES MAY BE LOWER

SPECIAL SOFTWARE COUPON

We pack a SPECIAL SOFTWARE DISCOUNT COUPON with every COMMODORE 64 COMPUTER, DISK DRIVE, PRINTER, or MONITOR we sell! This coupon allows you to SAVE OVER \$250 OFF SALE PRICES!!

(Examples)

PROFESSIONAL SOFTWARE COMMODORE 64

Name	List	Sale	Coupon
Paperback Writer 64	\$99.00	\$39.95	\$29.95
Paperback Database 64	\$69.00	\$34.95	\$24.95
Paperback Dictionary	\$24.95	\$14.95	\$10.00
The Print Shop	\$44.95	\$27.95	\$26.95
Halley's Project	\$39.95	\$25.95	\$24.95
Practicalc (spread sheet)	\$59.95	\$19.95	\$14.95
Voice Command Module	\$79.95	\$39.95	\$34.95
Nine Princes in Amber	\$32.95	\$24.95	\$21.95
Super Bowl Sunday	\$30.00	\$19.95	\$17.95
Flip & File Disk Filter	\$24.95	\$14.95	\$12.95
Pro Joystick	\$19.95	\$12.95	\$10.00
Computer Care Kit	\$44.95	\$29.95	\$24.95
Dust Cover	\$ 8.95	\$ 6.95	\$ 4.60
File Writer (by Codewriter)	\$39.95	\$29.95	\$24.95
C64 Troubleshoot & Repair Guide	\$24.95	\$15.95	\$12.95
Financial Planner — Sylvia Porter	\$59.95	\$38.95	\$35.95

(See over 100 coupon items in our catalog)

Write or call for
Sample SPECIAL SOFTWARE COUPON!

ATTENTION Computer Clubs

We Offer Big Volume Discounts
CALL TODAY!

PROTECTO WARRANTY

All Protecto's products carry a minimum 90 day warranty. If anything fails within 90 days from the date of purchase, simply send your product to us via United Parcel Service prepaid. We will IMMEDIATELY send you a replacement at no-charge via United Parcel Service prepaid. This warranty proves once again that **We Love Our Customers.**

* C128 COMMODORE COMPUTER \$289.00

You pay only \$289.00 for the C128 computer and we include the C128 Wordwriter Wordprocessor by Timeworks (Sale \$59.95). Thus, your net cost for the C128 computer is only \$229.05. List \$349.00. **SALE \$289.00.**

340K 1571 COMMODORE DISK DRIVE \$259.00

Double Sided, Single Disk Drive for C-128 allows you to use C-128 mode plus CPM mode, 17 times faster than 1541, plus runs all 1541 formats. List \$349.00. **Sale \$259.00.**

SUPER AUTO DIAL MODEM \$29.95

Easy to use. Just plug into your Commodore 64 computer and you're ready to transmit and receive messages. Easier to use than dialing your telephone, just push one key on your computer! Includes exclusive easy to use program for up and down loading to printer and disk drives. **Best in U.S.A.** List \$99.00. **SALE \$29.95. Coupon \$24.95.**

VOICE SYNTHESIZER \$39.95

For Commodore-64 computers. Just plug it in and you can program words and sentences, adjust volume and pitch, make talking adventure games, sound action games and customized talkies!! PLUS (\$19.95 value) TEXT TO SPEECH program included FREE, just type a word and hear your computer talk — ADD SOUND TO "ZORK", SCOTT ADAMS AND OTHER ADVENTURE GAMES!! (Disk or tape.) List \$89.00. **SALE \$39.95**

12" MAGNAVOX (NAP) 80 COLUMN MONITOR WITH SOUND \$79.95

Super High Resolution green screen monitor, 80 columns x 24 lines, easy to read, plus speaker for audio sound included. Fantastic value List \$129.00 **Sale \$79.95.** (C128 cable \$19.95, C64, Atari cable \$9.95)

PRINTER/TYPEWRITER COMBINATION \$229.95

"JUKI" Superb letter quality, daisy wheel printer/typewriter combination. Two machines in one — just a flick of the switch. 12" extra large carriage, typewriter keyboard, automatic margin control and relocate key, drop in cassette ribbon! (90 day warranty) centronics parallel or RS232 serial port built in (Specify). List \$349.00. **SALE \$229.95. (Ltd. Qty.)**

14" RGB & COMPOSITE COLOR MONITOR \$259.95

Must be used to get 80 columns in color with 80 column computers (C128 - IBM - Apple). (RGB Cable \$19.95) Add \$14.50 shipping. List \$399.00. **SALE \$259.95.**

- LOWEST PRICES • 15 DAY FREE TRIAL
- BEST SERVICE IN U.S.A. • ONE DAY EXPRESS MAIL

PHONE ORDERS

8 a.m. - 8 p.m. C.S.T. Weekdays
9 a.m. - 12 noon C.S.T. Saturdays

- 90 DAY FREE REPLACEMENT WARRANTY
- OVER 500 PROGRAMS • FREE CATALOGS

Add \$10.00 for shipping, handling and insurance. Illinois residents please add 6% tax. Add \$20.00 for CANADA, PUERTO RICO, HAWAII, ALASKA, APO-FPO orders. Canadian orders must be in U.S. dollars. WE DO NOT EXPORT TO OTHER COUNTRIES, EXCEPT CANADA. Enclose Cashier Check, Money Order or Personal Check. Allow 14 days for delivery. 2 to 7 days for phone orders. 1 day express mail! Prices & Availability subject to change without notice. VISA — MASTER CARD — C.O.D. No. C.O.D. to Canada, APO-FPO

PROTECTO

We Love Our Customers

Box 550, Barrington, Illinois 60010

312/382-5244 to order

Canon's Canonvision Model VM-E1 8-mm Camcorder

Giant camera maker Canon U.S.A. has added an 8-mm camcorder to its video-cassette portable line, joining a growing number of manufacturers entering models with this format.

Canon's new Model VM-E1 is a luxury-class unit that has virtually everything one could want in a portable VCR if you include a few of its options. The camcorder weighs in at 4.4 lbs without battery and measures a moderate $5\frac{1}{8}''\text{W} \times 13\frac{1}{8}''\text{D} \times 5\frac{1}{8}''\text{H}$. Its suggested retail selling price is a heavy \$1500, though, with an added \$200 for an accessory kit that includes a power adapter, audio/video/r-f playback adapter, as well as an optional remote-control unit and other items.

The Goodies

The VM-E1's sections are easily assembled (and disassembled). That is, the main body has a mounting shoe that holds an electronic viewfinder, an accessory shoe for mounting a carrying handle and neat "rails" at the rear of the unit to accommodate a choice of two Canon battery packs.

Equipped with a $\frac{1}{2}''$ Saticon™ camera tube, an f/1.2 power zoom lens system and a macro mechanism, there is not much else one could want in terms of the camera working end of the unit. Of course, focus is automatic (defeatable).

In keeping with Canon's camera-making heritage, this is really a "system" when one considers some options: wide-angle and telephoto converters to go beyond its 8.5-51 mm focal length, filter sets, a character generator, shoulder brace, microphone boom, car battery adapter, chest pod, system carrying case, and the like.

The built-in electronic viewer provides a 0.7" black-and-white playback picture for viewing live recordings and prerecorded tapes while being used as a portable. An electret unidirectional mic is located at one end, while the viewer is located at the opposite end with an eyecup and diopter adjustment ring for the user's convenience.

Most of the controls are on the left side of the camera body. On the right side there is a single stop-start button and the $6\times$ zoom lens T/W controls for two fingers and the thumb to manipulate.



In addition to having automatic focus, as well as being able to switch to manual if you wish to, there is a "one-shot" focus setting in the manual mode that will lock in the focus automatically for you and not change should a large object (say, a person) suddenly cross in front of the viewing area.

Furthermore, white balance is automatic and held in memory for an hour or so. There's a memory button, too, that will enable one to automatically go to a selected portion of the tape, as well as fade in-fade out control of both picture and sound. It can be used for a three-second fade.

To its features add an LCD window that displays all operating functions being used, warnings such as a "dew light" should condensation be a problem or a weak-battery indication, as well as the usual rewind/playback/fast forward, et al, controls. As you can see, this is no stripped-down model.

Lab Testing

Laboratory tests tell a lot about the new Canon 8-mm model, though not all, of

course. With charts developing standard signals as defined by the Electronic Industries Association (EIA), Tektronix and Hale Charts, analysis by the numbers should be quite accurate, though.

As the photographs published here show, the Canon's high-frequency response is excellent, extending to at least 3 MHz. This is better than many VHS and Beta VCRs. [Why Canon specs the model at 300 lines with a parenthetical "camera section," which is very roughly 3.75 MHz, makes one wonder.—Ed.] Equally fine is its measured 400 lines of vertical resolution, as measured on Tektronix' circular chart.

However, Tektronix' I and Q chroma evaluation chart, which excites colors between 400 and 800 kHz (depending on partial chart exposure) did not produce exceptional lavenders or deep blues. Moreover, the Hale color chart, with its three NTSC primaries and complements, wasn't well represented in yellows and reds. Following this, the crossed bandolier of 9 gray-scale steps sags in the middle, while the upper portion has more amplitude than the lower portion.

Sensitivity was fine at the 19-lux

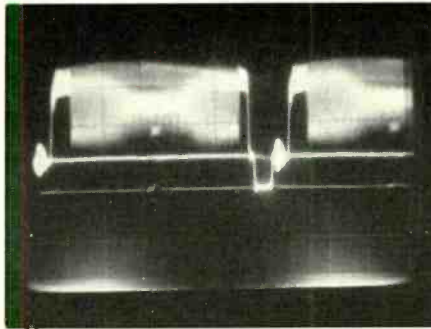
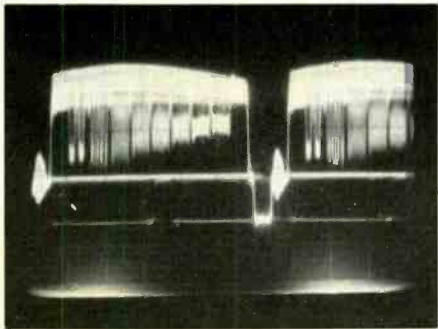

Good horizontal (high-frequency) resolution, left, measured an easy 3 MHz. Vertical resolution at 400 lines, right, was also very good.

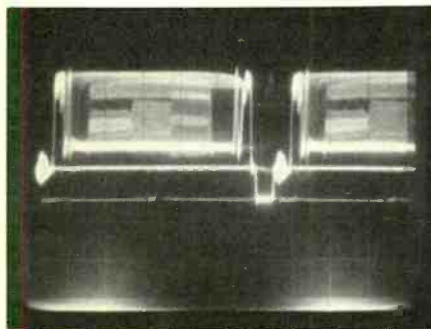
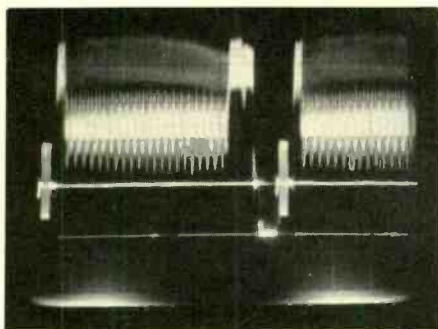

The Tektronix color chart (at the left) reveals that better indoor color reproduction is to be desired, but outdoor results are quite acceptable. The Hale color chart (at the right) indicates improvements needed for yellow and red indoor reproduction.

Canon Model VM-E1 Camcorder Laboratory Analysis

Camera tube	½" Saticon
Low-light sensitivity	19 lux
Lens	f/1.26 × zoom with macro
Record/play time	120 minutes maximum
Recommended tape	metal particle (MP)
Tape speed	9/16 ips
Stop/start time	0.5 second
Rewind time (90-minute tape)	3 minutes (approx.)
Video S/N	40 dB
Video high-frequency response	3 MHz
Video vertical resolution	400 lines
Grayscale tracking	fair
Color tracking (indoors)	fair
Audio S/N at 2 kHz	48 dB
Audio frequency response (mono)	5 Hz to 10 kHz, -3 dB
Power consumption at 117 V ac (Play/record)	5.57/9.32 wrms

Note: All responses measured through RU-E1 r-f baseband outputs.

Test Instruments: Tektronix Models 7L5 and 7L12 spectrum analyzers; Hameg Model HM605 oscilloscope; B&K-Precision Models 3020 function generator and 1653 ac power source; Data Precision Model 945 multimeter; RCA Model FLR2622T TV receiver/monitor; Tektronix Model C-5C camera; Kodak P6-120 MP videocassette; Technics Model SA-350 stereo receiver with Jensen speaker systems.

claimed. Video signal-to-noise ratio, though, at 40 dB, was not as good as the specified 47 dB, although the figure measured is par for the course.

As for audio, our examination revealed a maximum useable range to about 10 kHz in contrast to Canon's 14-kHz claim.

User Comments

This camcorder exhibits many unusual assets, not the least of which is a fine sense of physical balance and unusually good handling ease. The zoom worked smoothly and is easy to control. The control clusters make it all so simple. For example, if you want a one-shot focus scene while in manual or complete fadeout of picture and sound, touch two buttons over the lens and all is done. After you've completed a scene and are still in the pause/record mode, momentary contact of the review button is all that's needed to replay at least five seconds of all just-recorded material. And should you wish to see it all, simply press the play mode and enjoy it right through the viewfinder.

I found the liquid-crystal display, which also incorporates an electronic tape counter with memory, to be highly visible, as these displays go.

One does have to be somewhat careful of white balance, I learned. The green lamp in my viewfinder never stopped blinking indoors, regardless of flood lighting, but the recorded signal, exposure line indicator and battery/tape-end indicators worked like a charm.

Insofar as color pictures played back, there are always tradeoffs. For example, when a camcorder possesses relatively high definition, outdoor colors are quite acceptable to the eye. Indoors on test patterns, however, finds deep blues, purple and red to be affected, even under standard blue floodlights in daylight mode. And does a little sag among gray-scale steps make that much difference to the eye of the beholder?

Also, very high signal-to-noise video measurements often translate into narrower bandwidths (less detailed pictures), but better low-light color. So you either accept marginal definition and probably a better quality of low-light color or fairly good definition and a loss of some color,

Check Digital IC's in-circuit Fast!

In the field or
on the bench.
B&K-PRECISION
gives you the
answers for
TTL or CMOS



Model 550 (for TTL) \$395
Model 552 (for CMOS) \$395

New B&K-PRECISION IC Comparator Testers/Logic Monitors put you on the fast track to digital troubleshooting. IC's are tested by comparison to a known good device, allowing you to test hundreds of types with one simple operation.

As logic monitors, they simultaneously indicate the logic states of up to 20 IC pins. No need to check pins singly with a logic probe.

Tests most 14 to 20 pin, 54 and 74 Series TTL (Model 550) or 4000 and 74C Series CMOS (Model 552) devices.

- Convenient one button testing
- Reverse polarity and overvoltage protection
- Uses power from equipment under test
- Memory stores short duration pulses and intermittent events
- Zero insertion force reference IC socket
- LED at each IC pin identifies where fault exists
- Includes 16 and 20 pin DIP clips
- Compact hand-held size

Available from stock at your local B&K-PRECISION distributor. For more information contact your distributor or:

B&K PRECISION
DYNASCAN
CORPORATION

6460 West Cortland Street
Chicago, Illinois 60635 • 312/889-9087

International Sales: 6460 W. Cortland St., Chicago, IL 60635
Canadian Sales: Atlas Electronics, Ontario
South and Central American Sales:
Empire Exporters, Plainville, NY 11803

CIRCLE 49 ON FREE INFORMATION CARD

PRODUCT EVALUATIONS...

Canon's Model VM-E1 continued...

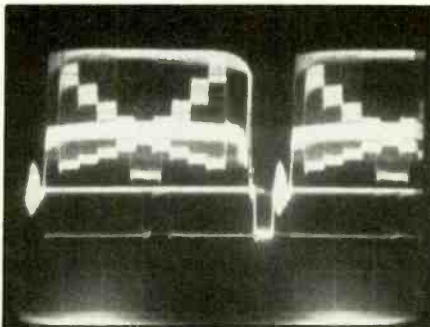

Grayscale trace shows some sag and its top is exaggerated, but this was not more than was expected.

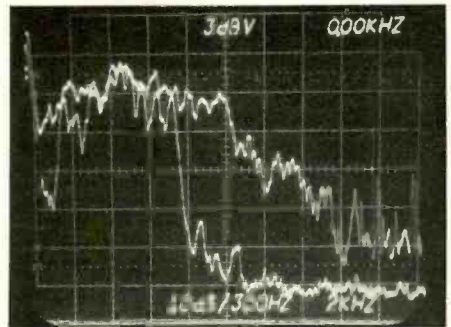

Audio reproduction at 2 (upper trace) and 0.5 (lower trace) kHz/division is not especially smooth and shows no more than 10 kHz usable frequency response.



R-f unit has a vhf output and separate video/audio inputs and outputs.

especially in poorly illuminated indoor scenes. The Canon falls more into the latter category.

The model's macro function is surely a competent performer. With it, it is easy to get sharp closeups to as near as $\frac{1}{6}$ ", all while watching through the viewfinder. It's a great feature to have if you're a stamp or coin collector, or a flower or insect enthusiast.

In our judgement, the VM-E1 and accessory-kit combination is quality merchandise at a competitive price. It's good equipment all the way.—Stan Prentiss.

Counterpoint

C'mon Stan. How many \$1,700 buyers are out there who are "live" recordists? Yes, this is a competitive price, but, hopefully, there will be lots more competitors coming up who will drive the price down.

On top of this, the model does not appear to be an all-round great performer, based on the "trade-offs" you yourself cited. And I don't get digital hi-fi stereo sound so that one can use the camcorder as a good stereo/high-fidelity deck, or a timer, nor are there special effects functions available.

Furthermore, why didn't you mention the octopus of wires and contrivance that must be attached to the camcorder in order to make it a "home" unit after schlepping it around and using it on battery power? Just think: you need Canon's CA-E1 compact power adapter that has to be plugged into an ac power outlet, its RU-E1 unit that has to connect between it and the camcorder, another RU-E1 line

(VHF Out) to connect to a separate Canon antenna selector, and two more connection lines from the selector that goes to the standard TV set's VHF input and to the antenna (with a 300-ohm to 75-ohm adapter, to boot). Then add a wired remote-control line and you've likely missed whatever you might have wished to record from TV in the first place.

Anyone going through the foregoing hookup hassle for a non-permanent setup, which a portable unit like this camcorder has to be considered, would have to spring for an 8-mm playback deck to avoid it all, as well as buy some costly accessories. A permanently connected "cradle" would be much better.

So my conclusion is not quite as enthusiastically positive as yours, though the model is nice enough. I think it's too much (cost) for not quite enough in terms of performance and built-in functions (primarily digital sound).

—Art Salsberg.

EXPAND YOUR CAREER HORIZONS...



The CIE Microprocessor Trainer helps you to learn how circuits with microprocessors function in computers.

START WITH CIE.

Microprocessor Technology. Satellite Communications. Robotics. Wherever you want to go in electronics... start first with CIE.

Why CIE? Because we're the leader in teaching electronics through independent study. Consider this. We teach over 25,000 students from all over the United States and in over 70 foreign countries. And we've been doing it for over 50 years, helping thousands of men and women get started in electronics careers.

We offer flexible training to meet your needs. You can start at the beginner level or, if you already know something about electronics, you may want to start at a higher level. But wherever you start, you can go as far as you like. You can even earn your Associate in Applied Science Degree in Electronics.

Let us get you started today. Just call toll-free 1-800-321-2155 (in Ohio, 1-800-362-2105) or mail in

CIRCLE NO. 171 ON FREE INFORMATION CARD

the handy reply coupon or card below to:
Cleveland Institute of Electronics,
1776 East 17th Street, Cleveland, Ohio 44114.

CIE **World Headquarters**

Cleveland Institute of Electronics, Inc.
1776 East 17th Street • Cleveland, Ohio 44114

Please send your independent study catalog.
For your convenience, CIE will try to have a representative contact you — there is no obligation.

Print Name _____

Address _____ Apt. _____

City _____ State _____ Zip _____

Age _____ Area Code/Phone No. _____

Check box for G.I. Bill bulletin on Educational Benefits

Veteran Active Duty **MAIL TODAY!**

Just call toll-free 1-800-321-2155 (in Ohio, 1-800-362-2105)

MO-54



New Electronic Products Coming Up

*A roundup of new video, audio and
other consumer electronics models*



Sharp Model VC-685U "High Quality" VHS VCR.

By Joe Desposito

Just as records are made to be broken, electronics products are made to be enhanced, refined, and otherwise improved so that this year's products are better than last year's, and next year's are even better again. What are the enhanced, refined and improved products that mark the year 1986? And what are some of the trends in electronics that are influencing products that will appear in 1987 and beyond? A recent industry gathering showcased the current crop of leading-edge electronics products and gave hints of what is to come in the near future.

Digital Invades Video

Though television receivers are as common as bathtubs in U.S. households, products that attach to them and even the receivers themselves con-

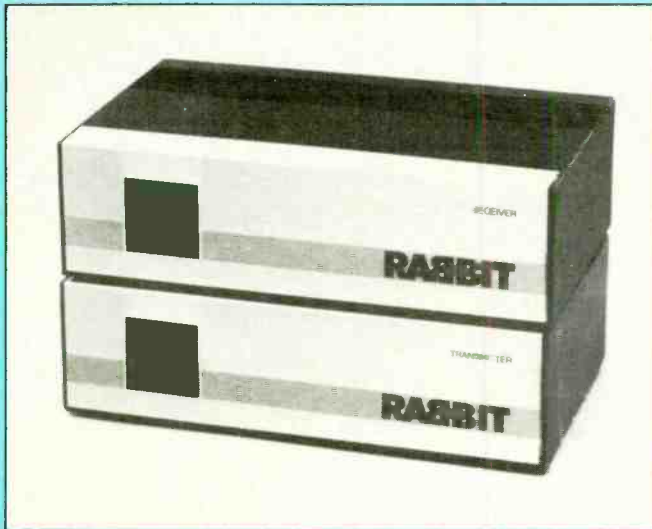

Rabbit Systems "VCR Rabbit" accessory.



Panasonic "Pocket Watch" 3.5" LCD color TV set. ▶

tinue to make technological advances. Take, for instance, VCRs. This year you will be seeing a new feature available on most high-end video recorders. It is called HQ for high quality.

The HQ feature boosts signals during recording so that the edges of objects in pictures appear cleaner. The process is called white-clip expansion. Additional circuits reduce noise, which helps eliminate the grainy, snowy look of some video pictures.

For those who can't get enough of the fare that VCRs offer, there is a device available that allows you to multi-

ply the number of units in your home. It is called, appropriately enough, the VCR-Rabbit and is manufactured by Rabbit Systems (233 Wilshire Blvd., Santa Monica, CA 90401). The VCR-Rabbit consists of a transmitter that is placed on the VCR and a receiver that is placed on the receiving television. Mini-thin wire is used to connect the transmitter to the receiver(s).

Why not a wireless version? The original Rabbit was a wireless version, but it did not meet FCC approval. A remote-control version of the product retails for \$79.95, while a standard ver-

sion costs \$49.95. Additional receivers are \$39.95 and \$29.95, respectively.

Television receivers continue to improve, both small screen and big screen. Panasonic's (One Panasonic Way, Secaucus, NJ 07094) Pocket Watch is a slim-line 3"-diagonal LCD color TV that weighs less than a pound. The display features 240 x 372 pixels and a thin-film transistor active matrix system. The transistors allow for subtle variations in hue and color intensity.

Technological innovations in the Pocket Watch include multi-gap color

Kloss Video Novabeam 100 projection TV system.

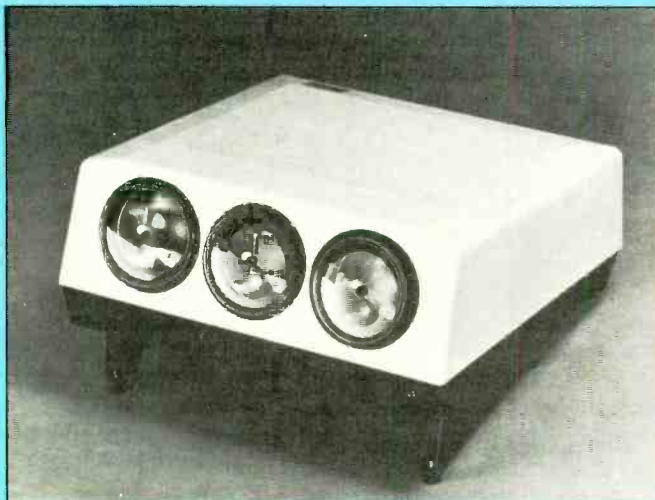

Sanyo 8-mm Model VM 8 camcorder.



LCD panel, triangle color formation, and black matrix, which dramatically improve contrast and overall picture quality. And, of course, there is an audio/video input jack for the VCR crowd. Suggested retail cost of the Pocket Watch is \$299.

In his never-ending battle to bring genuine theatre-quality video into the home, Henry Kloss has developed the new Novabeam 100 Projection TV. The unit comes in three screen sizes: 5, 6.6 and 10 feet (diagonal).

The Novabeam 100 is the first consumer video product to employ Faroudja Processing. The video processing circuit, invented by Yves Faroudja, is said to restore much of the original detail lost in recording or broadcast of video material without introducing visual side effects such as ghosts or outlines.

The Novabeam 100 also contains an improved version of the Novatron, Kloss Video's (640 Memorial Dr., Cambridge, MA 02139) patented projection tube that uses a high-speed

(f/0.7), telescope mirror to put the picture on the screen.

If you do a double take the next time you look at a normal-size television, it may be due to the two pictures on the screen. This feature can be found on the new digital TVs that are available from several manufacturers. With a digital TV, it is possible to press a button and have a window appear on the screen. This lets you peek at what is happening on another program source. For example, you can bring up a window on the late night news while watching a movie from your VCR. Another typical digital feature allows you to freeze a frame in the window.

Where there are VCRs and TVs, you are likely to find video cameras. And the new cameras on the market give a clear indication that the 8-mm tape format is here to stay. Six manufacturers—Sony, Sanyo, Canon, Goldstar, Samsung, and Aiwa—have introduced new 8-mm camcorders.

Two of the most interesting video products may not show up in the

marketplace for another year or so. Both are from Toshiba (82 Totowa Rd., Wayne, NJ 07470). The first is a digital VCR. The digital M-6900 has 1.15 megabits of RAM, which is used to store images. Conventional VCRs achieve special effects such as freeze-frame and slow-motion through the repetition of an intermittent play/stop movement of the tape against the head. This results in bar noise and an unstable screen image.

The M-6900 uses an analog-to-digital converter to select and store images in its memory. The stored images are then reproduced on a real-time basis. The result is a noise-free, vivid picture. Besides freezing frames from a video tape, it can also freeze frames from broadcast television. Of course, once you deactivate the freeze mode, you'll find that you've missed some of the program you've been watching.

The other product is a television receiver that improves the quality of the picture by using a noninterlace scanning technique. Conventional TVs use

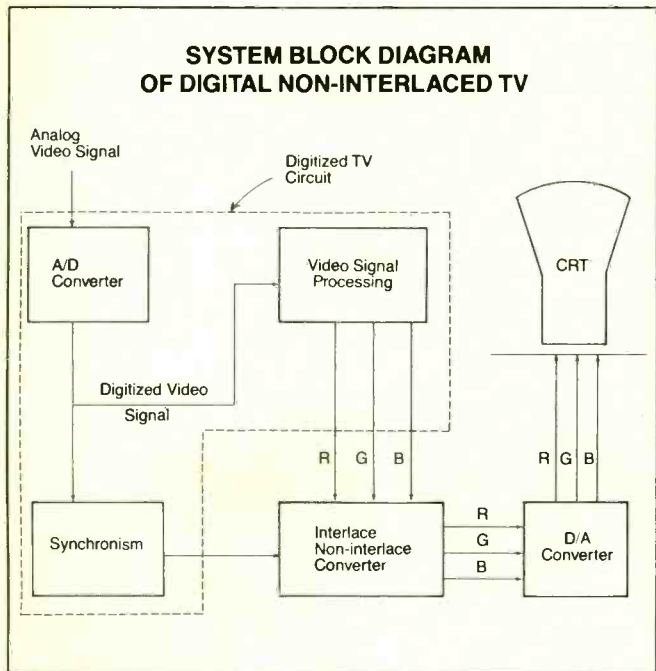
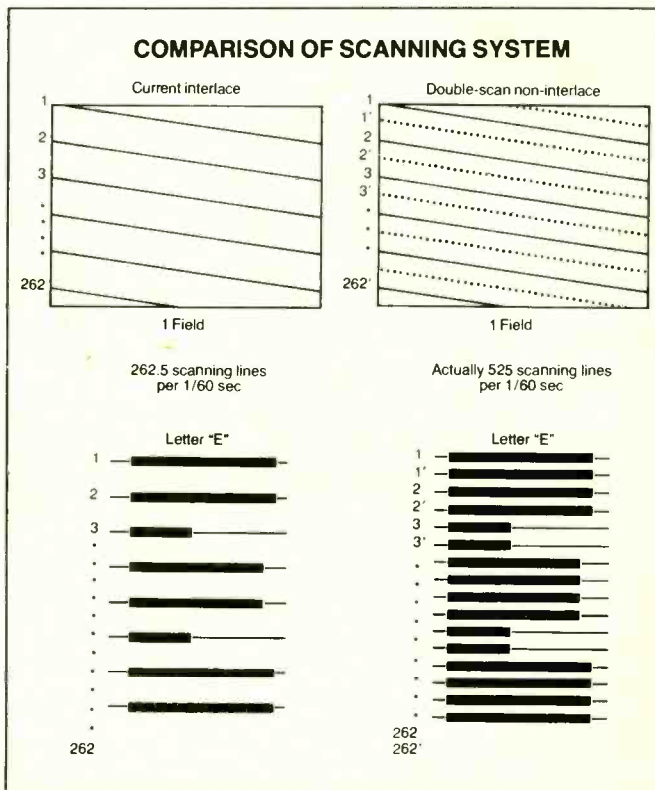

Fig. 1. Analog signal is converted into digital form.

Fig. 2. Digital signal is converted back to analog form to provide full-resolution 525-line scan.





Discwasher "Video Starter Kit."

Sansui Cinemasound adjustable-reflector rear speakers. ▀

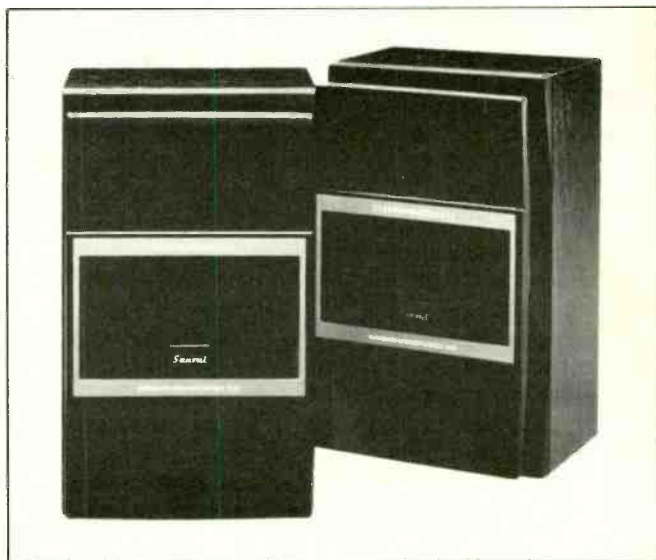

the interlace method, which displays 262.5 (of 525) scanning lines of video information every 1/60th second. By using digital circuitry (Fig. 1), the analog broadcast signal is converted into a digital signal in which the horizontal deflection frequency is doubled to complete the missing scanning lines per field. Then this enhanced filled-in signal is converted back to analog to be viewed on the screen. Thus, rather than 262.5 lines, the viewer now sees the full 525 lines every 1/60th second with minimal flicker (Fig. 2).

Toshiba's enhanced television works with ordinary broadcast signals, and it displays an improved picture, but there is still high-definition TV waiting in the wings in case television standards are ever changed in this country. NEC's High Definition Television has a 20-MHz bandwidth, scans 1125 lines, and has a 3:5 aspect ratio. The effect is so stunning that it looks like you are viewing a real life scene through a window.

No discussion of video would be complete without mention of the accessory products that all owners of video equipment need. The one I like best is a video starter kit from Discwasher (4309 Transworld Rd., Schiller Park, IL 60176). It provides all the necessary cables and switches that you

usually need but don't purchase when you buy your video recorder. Instructions for hooking the VCR to cable systems and a video head cleaner are also included in the package, which retails for \$29.95.

The Sound Around Us

Special sound effects have been recorded on VCR tapes for years, but you need a decoder to hear them. You are probably familiar with "Surround Sound" if you frequent theaters with 70-mm Dolby sound systems. It gives you a realistic effect, such as in Rocky IV, when you actually feel like you are at the big fight.

To achieve the surround sound effect in the home you need a special decoder as well as extra speakers placed to the left and right of the listener. One company among others that markets such a decoder is Surround Sound, Inc. (14025 Panay Way, Marina Del Rey, CA 90292). Its SSI-720 is a full logic Dolby Surround decoder that incorporates the same type of logic steering and automatic calibration circuitry found in Dolby theater systems.

A Dolby Stereo encoded movie actually contains not two, but four channels—left and right front, plus a center front channel and a monaural



Nady Infrared wireless stereo headphones system.

special effects rear channel. The SSI-720 decodes all the available Dolby Stereo information on tapes and discs, including the Dolby B encoded rear channel. The SSI-720 retails for \$599.95.

The surround or rear speakers are used primarily for ambient sound and thus do not require the same input wattage or output level as the front speakers. Typical surround-sound speakers are Sansui's (1250 Valley

Brook Ave., Lyndhurst, NJ 07071) S-10 speakers, for \$150 per pair.

Rather than have speakers all around, some people prefer to cuddle up on the couch with a pair of headphones. A new product from Nady Systems, Inc. (1145 65th St., Oakland, CA 94608) lets you do this and cut the cord as well. Nady's infrared cordless headphones let you move around the room free of the restraining effects of a headphone cord.

Besides the headphones, there is an infrared stereo transmitter that plugs into any stereo or tape deck's headphone jack. An infrared signal is transmitted to a sensor on top of the cordless headphones. Suggested retail price of the system is \$119.95. System range is about 25 feet and any number of headphones (\$59.95) can be used with the transmitter.

One product that attempts to solve the problem of stolen audio—in cars, that is—is something called the DriveMan from Clandestine Car-Audio (P.O. Box 733, Sudbury, MA 01776). If your car has been broken into once too often, you can install the DriveMan under your dashboard hidden from view, this car-sound device makes a prospective car-radio thief think you do not have anything worth stealing. To use it, you need to connect the output of a Walkman/Discman type personal stereo system to the input on the DriveMan. The DriveMan will then boost the audio output to drive the car speakers.

Two important new audio products may debut before the year is over. One of them is a new tuner by NAD (675 Canton St., Norwood, MA 02062), which has a decoder for FMX broadcasts. FMX is the system that was jointly developed by CBS and the National Association of Broadcasters. The FMX extended-range FM stereo system features a 20-dB reduction in noise, improved stereo reception at greater distances, and 90-dBS/N ratio in strong areas.

Another important new audio product is Onkyo's (200 Williams Dr.,



Onkyo Model DT-1000 digital audio cassette deck.

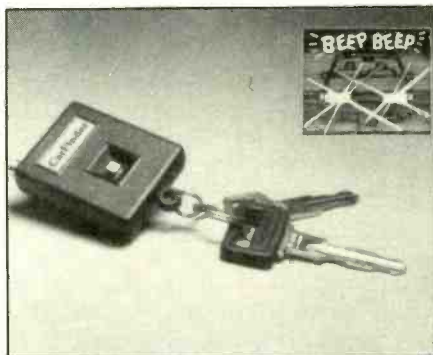

DesignTech Model 007 "CarFinder."

Ramsey, NJ 07446) DT-1000 digital audio tape recorder. Its R-DAT (rotary digital audio tape) format allows the use of a cassette two-thirds the size of a standard audio cassette, with up to two hours recording and playback time possible. Rotary head scanning, similar to video recorders, provides for large amounts of infor-

mation to be carried on a very narrow tape width.

The DAT system offers the ability to record at a 48-kHz sampling rate, which is a theoretical increase over the compact disc. It parallels the resolution provided by professional studio equipment that record using the same 48-kHz sampling frequency.

For Your Car

There are a bevy of helpful electronic items for automobile owners that are newly marketed. Among them is Car-Finder, which enables you to quickly locate your parked car up to 750 feet away. It includes a 1.4-oz. keychain transmitter and an under-dash receiver. Just push the keychain button and your car's horn honks and its lights flash. Retail price for this is \$99.50. (DesignTech, 941 25th St., NW., Washington, DC 20037.)

Willas "TaleLights" rear-window message panel.



Another automobile device that might well appeal to a lot of people is TaleLights (Willas USA, 8933 Quartz Ave., Northridge, CA 91324). This is a multi-message signboard that mounts in a rear-window area. It displays in large red letters one of 15 messages. Six are activated automatically (STOP, HAZARD, REVERSE, STOLEN and right and left turn arrows). Driver-activated messages are: HELP POLICE, BACK OFF, HIGH BEAMS, THANKS, CHILD IN CAR, OOPS, SORRY, HI CUTIES, and LET'S PARTY.

What Type of Speller Are You?

It wasn't long ago that typewriters were classified as electric rather than electronic. But today's new electronic typewriters are providing more and more benefits to users. Foremost among these (whoops!) is the spelling checker. Almost all the major brands of electronic typewriters, including Royal, Smith-Corona, and Olivetti, include this feature as an integral part of the typewriter or as an optional add-on accessory.

The spelling checker beeps whenever you type something that isn't in a dictionary of approximately 80,000 words. Most Models also allow you to insert words that you commonly use, such as proper names. These words then become part of the dictionary.

One group of electronic typewriters has gone beyond spelling to word processing. These are the computer-compatible typewriters from Smith Corona (65 Locust Ave., New Canaan, CT 06840). These typewriters can be connected to Smith Corona's Personal Word Processor (PWP), which is a separate unit that has a 24-line by 80-character 12" display monitor, microwafer tape drive, 64K RAM, and built-in word processing software. Suggested retail price for the PWP typewriter is \$499.99.

And speaking of word processors, someone has finally manufactured a low-cost dedicated word processor. It is from Magnavox (1111 Northshore Dr., Knoxville, TN 37919) and is called

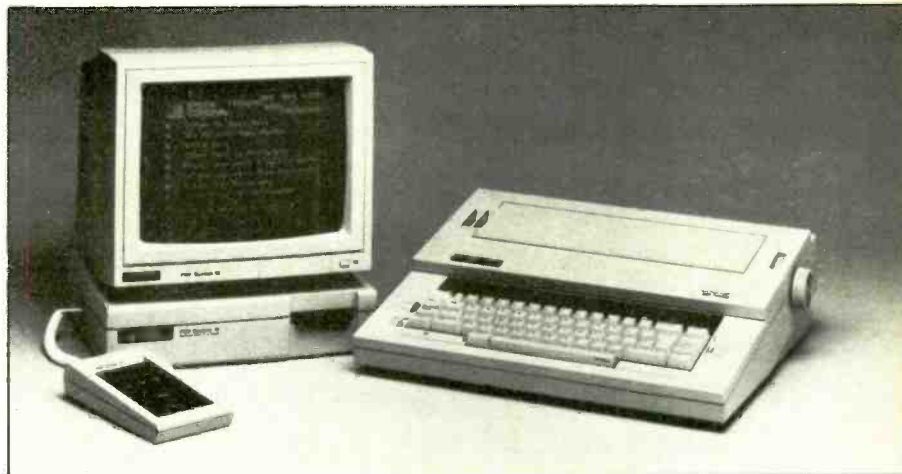

Smith Corona Personal Word Processor.



Magnavox Videowriter with built-in thermal printer.

the Videowriter. The Videowriter looks like a typical transportable microcomputer except that it has a built-in thermal transfer printer (which works with standard paper when you insert a ribbon cartridge).

The Videowriter features an amber screen that displays 18 lines of 80 characters, a 3.5-disk drive, a dedicated word processing keyboard, and built-in word processing software and 50,000 word dictionary. Suggested list price of the unit is \$800.

Answering the Calls

Most telephone answering machines

have features that have been around for a few years. But some new products have added twists to the usual array of features. An entire line of products from Record-a-Call (19200 S. Laurel Pk. Rd., Compton, CA 90220) feature a one-button system to perform all the standard answering machine tasks. For example, if you have messages waiting, a press of one button will play all the messages and then rewind the tape to the beginning to ready the machine for new messages.

Ease-of-use is also evident in the answering machines from Phone-Mate (325 Maple Ave., Torrance, CA

90503). If you've ever forgotten (or never learned) how to use your answering machine in remote mode, you would appreciate Phone Mate's remote voice menu feature. A computer voice presents options such as saving, replaying, erasing messages, or recording a new greeting. A touch of a button on the telephone keypad activates the command. The digitized voice is also used in normal operation to time and date stamp messages.

What does the future look like for answering machines? Code-A-Phone has a prototype of what answering machines might be like in a few years. The answering machine is completely solid-state and needs no tapes. Rather, the user's outgoing announcement and incoming messages are encoded on a microchip. A unique feature of the machine would be the ability to skip from the middle of one message to the beginning of the next instantaneously at the touch of a button.

One phone that has a special way of answering, although it is not an answering machine, is a voice activated speakerphone from Ameriphone (1140-FN. Kraemer Blvd., Anaheim, CA 92806). A simple "Hello" answers the phone up to 10 feet away. And the phone automatically hangs up when the conversation is over.

A Calculated Change

Though electronic calculators seem to stay the same year after year, there are always some changes that take place. Take the Casio (15 Gardner Rd., Fairfield, NJ 07006) graphic computers for example. These scientific calculators employ an enlarged display area so that graphs may be displayed on the screen. For instance, if you wanted to plot a sine curve or parabola or other curve, you could enter the function and its argument into the calculator and obtain a picture of the curve on the display. The FX-6000G and FX-7000G graphic computers retail for \$59.95 and \$69.95, respectively.

A custom-calculator that could

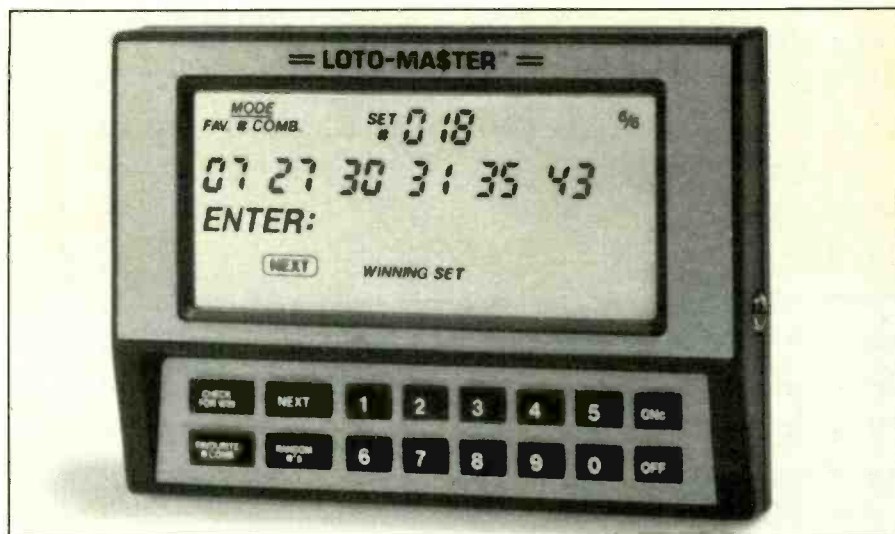

CVOS "Loto Master" personal lottery computer.

make you a millionaire is the Loto-Master from CVOS (160 Graveline, St. Laurent, Quebec, Canada H4T 1R7), a lottery number combination selector. Though I don't understand how it "improves players' chances," it does seem like a useful device for players like myself who always pick terrible numbers.

Paper Software

If you are tired of the same old precautions associated with floppy disks and need to change, why not try the Softstrip from Cauzin Systems (835 S. Main St., Waterbury, CT 06706). You'll only have to worry about ripping it. The Softstrip is a piece of paper that is a lot like a bar code, but with a lot more information crammed into the same space. A strip can hold up to 5,500 bytes in a 3/8" by 9 1/2" space. If a program or data uses more than 5500 bytes, several Softstrips can be linked together.

A special Softstrip reader is needed to download the information into a computer through an RS-232 interface. If the idea takes hold, you may see Softstrips appearing in many of your favorite computer magazines and books. The reader retails for under \$200.

On the conventional software front, a quite sophisticated drawing program has appeared for the Commodore Amiga. Called Aegis Draw, it allows you to create structured drawings with detailed precision and, of course, in color. It is from Aegis Development (2210 Wilshire Blvd., Suite 277, Santa Monica, CA 90403).

Another program of theirs is Aegis Animator, also for the Amiga. The program allows you to create different shapes on the screen and animate them in various ways. You can also create detailed backdrops using the Aegis Images paint system that is included with the animator. The product can be used both as a creative tool and a business tool.

A Concluding Note

After reading about all of these products you may want to start a youngster on his way to a career in electronics. Naturally, there is a new way to do this, too. A product call Bloc-Tronic lets you build electronic circuits by attaching electronic blocks together. Each block contains an electronic component, such as a wire, resistor, capacitor, etc. By combining the blocks with larger system blocks such as an IC-amp, you can build a functioning electronic device. **ME**

ELECTRONICS ENGINEERS' HANDBOOK, 2/e
by D. G. Fink & D. Christiansen
209/812 Pub. Pr., \$83.50 Club Pr., \$63.95

COMPUTER ARCHITECTURE, 3/e
by C. C. Foster & T. Iberall
583278-X Pub. Pr., \$38.95 Club Pr., \$29.25

THE ENCYCLOPEDIA OF ELECTRONIC CIRCUITS
by R. Graf
583265-8 Pub. Pr., \$50.00 Club Pr., \$39.95

GATE ARRAYS: DESIGN TECHNIQUES & APPLICATIONS
by J. Read
512/868 Pub. Pr., \$35.00 Club Pr., \$24.75

PHASE-LOCKED LOOPS
by R. G. Best, PHD
050/503 Pub. Pr., \$37.50 Club Pr., \$28.25

INTEGRATED CIRCUITS APPLICATIONS
by A. H. Seidman
582860-X Pub. Pr., \$47.95 Club Pr., \$33.95

OPTICAL COMMUNICATION SYSTEMS
by J. Gowar
582926-6 Pub. Pr., \$44.95 Club Pr., \$32.50

MICROWAVE SEMICONDUCTOR CIRCUIT DESIGN
by W. A. Davis
583044-2 Pub. Pr., \$47.50 Club Pr., \$35.50

HANDBOOK OF MICROCOMPUTER BASED INSTRUMENTATION & CONTROLS
by J. D. Lenk
582866-9 Pub. Pr., \$22.95 Club Pr., \$18.95

ELECTRONIC COMMUNICATIONS SYSTEMS
by W. D. Stanley
582834-0 Pub. Pr., \$32.95 Club Pr., \$22.50

MANUAL OF SATELLITE COMMUNICATIONS
by E. Fthenakis
225/94X Pub. Pr., \$44.50 Club Pr., \$31.95

MICROPROCESSOR AND MICROCOMPUTER DATA DIGEST
by W. H. Buchsbaum
582835-9 Pub. Pr., \$29.95 Club Pr., \$22.50

HANDBOOK OF TRANSFORMER APPLICATIONS
by W. M. Flanagan
212/902 Pub. Pr., \$49.50 Club Pr., \$36.75

STANDARD HANDBOOK OF ENGINEERING CALCULATIONS, 2/e
by T. G. Hicks
287/35X Pub. Pr., \$59.50 Club Pr., \$44.50

STANDARD HANDBOOK FOR ELECTRICAL ENGINEERS, 11/e
by D. G. Fink & H. W. Beaty
209/74X Pub. Pr., \$85.00 Club Pr., \$65.50

ELECTRONICS ENGINEERING FOR PROFESSIONAL ENGINEERS' EXAMS
by C. R. Hafer
254/303 Pub. Pr., \$32.50 Club Pr., \$25.50

MODERN ELECTRONIC CIRCUITS REFERENCE MANUAL
by J. Markus
404/461 Pub. Pr., \$79.50 Club Pr., \$57.95

ANTENNA THEORY: Analysis and Design
by C. A. Balanis
582493-0 Pub. Pr., \$41.95 Club Pr., \$29.95

ENGINEERING MATHEMATICS HANDBOOK, 2/e
by J. J. Tuma
654/298 Pub. Pr., \$41.50 Club Pr., \$31.00

Join the **ELECTRONICS AND CONTROL ENGINEERS' BOOK CLUB®**

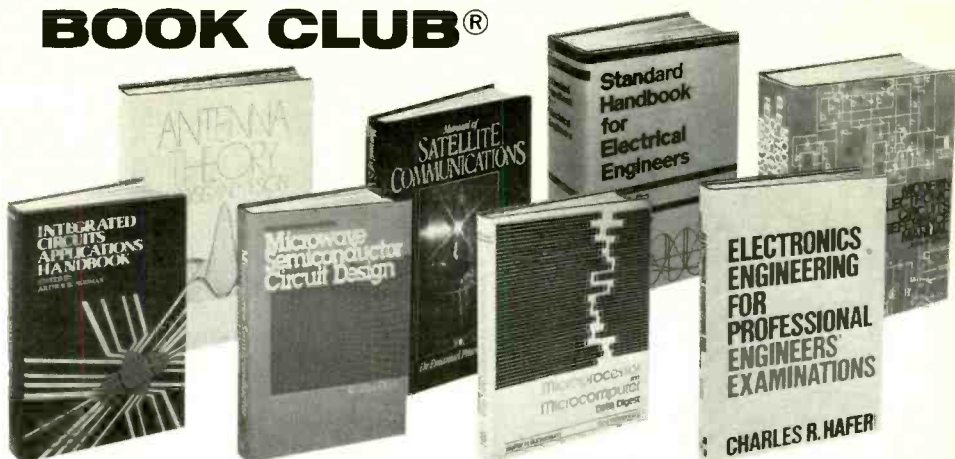

Get the competitive edge with the *newest* and the *best* information in your field . . . with books from all the leading publishers

New members! Any one of these great professional **\$289** books for only **\$289** as a premium with your first selection! values up to **\$85.00**

Why YOU should join now!

- **BEST AND NEWEST BOOKS IN YOUR FIELD**—Books are selected from a wide range of publishers by expert editors and consultants to give you continuing access to the best and latest books in your field.
- **BIG SAVINGS**—Build your library and save money too! Savings ranging up to 30% or more off publishers' list prices— usually 20% to 25%.

BONUS BOOKS—You will immediately begin to participate in our Bonus Book Plan that allows you savings up to 70% off the publishers' prices of many professional and general interest books!

- **CONVENIENCE**—12-14 times a year (about once every 3-4 weeks) you receive the Club Bulletin FREE. It fully describes the Main Selection and alternate selections. A dated Reply Card is included. If you want the Main Selection, you simply do nothing—it will be shipped automatically. If you want an alternate selection—or no book at all—you simply indicate it on the Reply Card and return it by the date specified. You will have at least 10 days to decide. If, because of late delivery of the Bulletin you receive a Main Selection you do not want, you may return it for credit at the Club's expense.

As a Club member you agree only to the purchase of three books (including your first selection) during your first year of membership. Membership may be discontinued by either you or the Club at any time after you have purchased the first selection plus two additional books.



MAIL THIS COUPON TODAY

McGraw-Hill Book Clubs Electronics and Control Engineers' Book Club® P.O. Box 582 Highstown, NJ 08520-9959	Write Code No. of the \$2.89 selection here <input style="width: 100%; height: 20px;" type="text"/>	Write Code No. of First Selection here <input style="width: 100%; height: 20px;" type="text"/>
Please enroll me as a member and send me the two books indicated, billing me for the \$2.89 premium and my first selection at the discounted member's price, plus local tax, shipping and handling charges. I agree to purchase a minimum of two additional books during my first year of membership as outlined under the Club plan described in this ad. A shipping and handling charge is added to all shipments.		
Signature _____ Name _____ Address/Apt. _____ City/State/Zip _____		
This order subject to acceptance by McGraw-Hill. All prices subject to change without notice. Offer good only to new members. E33789		



Reading by Computer

Optical data entry is explored, and the Oberon "Omni-Reader" that scans copy and inputs the data to a computer is examined

By John Richards

Although the modern business office uses a computer to "crunch" much of its routine facts and figures at lightning speed, except for rare exceptions the data itself is input to the computer manually by a typist pecking away at the keyboard.

The exceptions to the typist spending the entire workday transferring data into the computer from a previously prepared—and usually typewritten list—are mainframe installations equipped with an *optical character reader*, or OCR, a device which in a matter of a few dozen seconds can scan a printed document and convert the printed characters into electrical signals that the computer can process into a disk file, merge with existing files, or utilize as a real-time substitute for keyboard entry.

In the simplest of terms, the OCR device, or *scanner* as it is more commonly known, consists of a motor-driven photodetector that scans a document line by line at a fixed rate. The output of the photodetector is a varying voltage representing the individual characters on the printed page. Generally, an A/D (analog to digital) converter converts the photodetector's output to digital for processing by a microprocessor (actually a computer) built into the scanner. Also within the scanner is either ROM or RAM programmed with digital representations of the various typefaces (fonts) used for both conventional printing and typewriters.

Usually, the programming is done

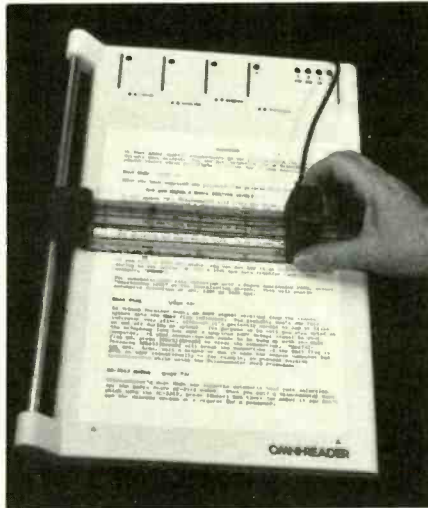

To store a document in your personal computer, you place it on an Omni-Reader and sweep the read head across each line of text or characters. This enters the data into your computer just as if you typed it in from the computer's keyboard.

in ROM for the commonly used fonts, such as Times Roman for printed materials; Pica, Elite, Prestige Pica, Letter Gothic, Judicial, Delegate, and Artisan for typewriters; and even the OCR font, which is specially designed for optical scanning (it's the typeface usually used to imprint your account number on personal and business checks).

The scanner's microprocessor matches the photodetector's electrical signals to the preprogrammed characters sets, determines what the scanned character actually is, and then outputs an electrical signal to the associated computer which the computer recognizes as a character.

Generally, the output from the scanner to the computer is in ASCII form because ASCII can be instantly integrated by the computer into any kind or type of text document: a letter, spreadsheet, data file, whatever. For example, assume the scanner's photodetector "reads" the character "A" (without the quotation marks). Whatever kind of signal is generated by the photodetector as it passes over the "A" is interpreted by the scanner's internal microprocessor as the character "A." Actually, the microprocessor has no idea the character is an "A" since it actually works with electrical representations. For example, if the microprocessor works in ASCII it will "see" a 41H (decimal 65), which is the ASCII code for "A" when the photodetector scans the character "A."

The microprocessor, in turn, outputs an ASCII code 65 to the main computer. It doesn't make any difference what kind of signal is generated by the photodetector as it scans across the printed "A" character as long as the scanner's output can be understood by the main computer. Some dedicated optical scanners do their own thing because they work with computers that recognize the output of one particular scanner or a common family of scanners. Nonproprietary scanners—that can be connected to almost any computer—generally output ASCII because this is the closest thing to a universal language for computer peripherals.

The usual purpose for using a lot of relatively expensive hardware to

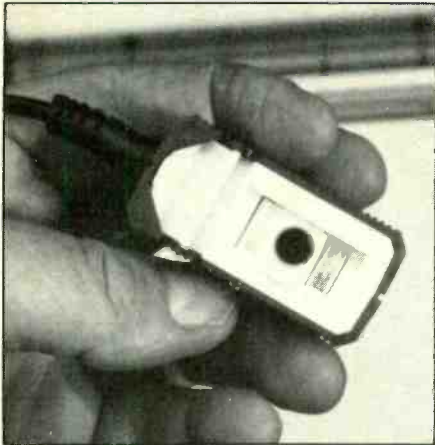

The actual character scanning is done by a photodetector buried within the read-head assembly. Two small lamps on either side of the decoder provide optimum illumination as the photodetector sweeps across a character being read.

convert printed text to our computer signals is to electronically store a document so that the original can be discarded, thereby reducing the amount of physical area needed to store documents that might be needed for reference at some future time. For example, an OCR device might be used by the local electric utility to electronically file customer complaints, while a student might store electronic copies of his or her research because it's faster to search an electronic file than to wade through boxes of perhaps thousands of loose papers.

The Budget Way

As you might expect, an automated device that can interpret a page of text into electrical codes in a matter of seconds costs *big bucks*, usually upwards of \$5000—which is often several times the cost of a commonly used personal computer. For the budget-minded user of personal computers, there's a much less expensive optical character recognition device called the Omni-Reader, from Oberon International Ltd.

Basically, Omni-Reader is a manual version of the automatic optical

scanner. In place of the automatic mechanism that causes a photodetector to scan a document there is a photodetector assembly with two control buttons that are positioned and moved by the user. The user presses one of the two buttons to activate the photodetector, sweeps the photodetector assembly across a line of text, and when the button is released the scanner outputs the line of text, in ASCII, to the associated computer. The second button is used to reset the system in the event something goes wrong with the scan. To ensure precise registration of the detector with the line of text, the assembly is secured to a special ruler (more on this later) that also contains a "clock code."

The complete Omni-Reader assembly consists of a plastic cabinet in the shape of a tablet that is slightly larger than a sheet of typing paper. The top surface contains a track that supports a "line ruler" and its "read" head (the photodetector scanner), a set of eight LEDs that indicate the operating modes, and imprints of four command codes which program certain scanner functions simply through movement of the read head. The scanner's own internal computer—the electronic hardware needed for character recogni-

tion—and a serial input/output port (I/O) are built into the tablet itself. Along the back edge (the rear when the tablet is flat for use) are connectors for a plug-in power supply and the optical read head; also, two sets of DIP switches. One set of switches determines the serial I/O baud rate; the other programs the serial I/O for either a modem handshake or Xon/Xoff, turns the internal warning beeper on and off, selects either 10- or 12-pitch character recognition, and programs either a "#" or "£" symbol for the relevant ASCII code. ("#" is used in U.S.; "£" is used overseas.)

Omni-Reader is preprogrammed to recognize the typefaces commonly used in business: 10- and 12-pitch Courier, 12-pitch Letter Gothic, and Prestige Elite 12. (According to the supplied manual, it is possible to download a different font, but no further mention is made of the subject. Perhaps the necessary software is for the future.

The user-selected font is indicated by one of five of the previously mentioned eight LEDs located across the top of the tablet. The remaining three LEDs show whether the Omni-Reader is in the LEARN, NEWLINE, or NUMERIC modes. LEARN is the mode when downloading a custom font.



The rear edge of the tablet contains, from left to right, a jack for the power supply, a socket for the read head connector, an RS-232 I/O, baud-rate DIP selector, and the DIP selector for 10 or 12 pitch, modem Xon/Xoff handshake, internal beeper on/off and # or £ selection.

NEWLINE is simply what it implies: when the button on the read head is released at the end of the line a carriage return is inserted so that the next character scanned starts a new line. If the reader isn't in the NEWLINE mode the characters simply append to the previously scanned characters. The NUMERIC mode programs the Omni-Reader to recognize only numeric characters; according to the manual this can speed up numeric entry of numbers.

As in almost everything that's digital there must be some way to clock the signal so that the computer knows what's going on. In the conventional *big bucks* OCR device, the photodetector or the image moves at a fixed or clocked, rate. Hence, the computer can be certain of what's taking place. On the other hand, the Omni-Reader's read head is moved manually, and can take from 0.5 to a couple of seconds to scan the line. Unlike the bar-code reader in your local supermarket, in which the normal tolerance is relatively broad because the photodetector works within a small limited area of thin and thick bars, manual scanning of the Omni-Reader is too wide and too variable; so a way is provided to "clock" the manual scan.

The clock is a series of short and long bars (actually elongated dots) imprinted across the ruler device which carries the read head. These dots are also illuminated along with the characters by two small lamps built into the read head, and the photodetector merges the dots into the pattern seen by the detector. This produces what is best described as a semi-bar pattern consisting of the elongated dots integrated with the "bar" pattern of the characters. Essentially, the read head is "seeing" a pattern of individual bars.

With The Keyboard

Software provided with Omni-Reader integrates the device's output with that of the keyboard for conventional programs such as word proces-

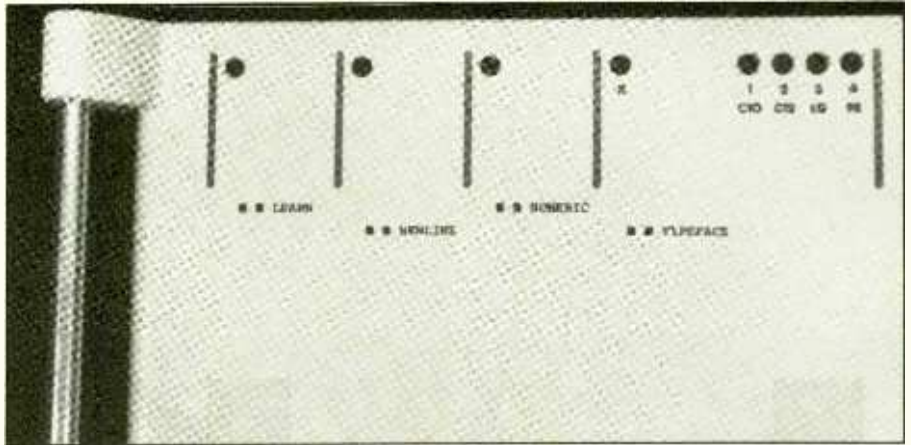

Light-emitting diodes across the tablet's top indicate operating mode(s) and selected character font. LEARN, NEWLINE, NUMERIC, and TYPEFACE functions are determined simply by sweeping the read head across words printed on the tablet.

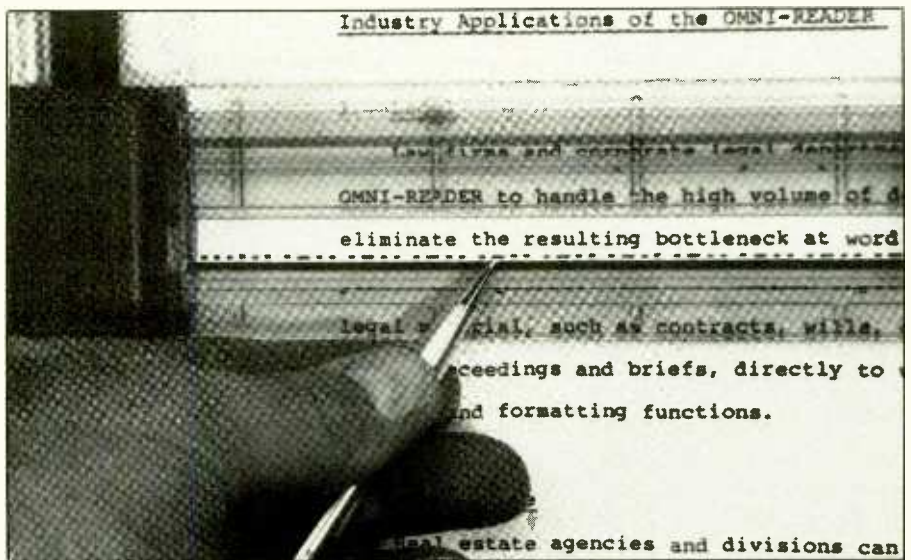

The pointer indicates the "clocking" marks printed on the bottom edge of the ruler that carries the read head. These marks are read along with the characters and provide the means by which the internal microprocessor can recognize individual characters as the read head scans a printed document.

sors, spreadsheets, etc. In plain English, "integration" means that the Omni-Reader's output is in parallel with the keyboard. For example, when word processing, you can type a line of text, then scan any number of lines or pages, and then resume typing; as far as the word processor is concerned all input originated from the keyboard.

It Really Works

Although the Omni-Reader does do

what its maker claims, as shown in accompanying illustrations, it takes considerable practice and effort to develop a scanning motion that doesn't drop characters or create typographical errors. Also, it was extremely difficult to generate blank lines without generating "garbage." (For illustrations, we used some printed text supplied with the device.)

Figures 1 and 2 are early attempts to scan the same typewritten copy. In Fig. 1, we had lots of problems with

Fig. 1

TEST SHEET: Read this first and retain for future reference
OMNI-READER by OBERON INTERNATIONAL LTD
This test sheet, in conjunction with your user manual, will provide all the information you will need to start using your Omni-Reader. If you have any Problems, consult your manual in greater detail.
uu..=u\$- tu\$...u..uu\$ \$.. u\$-u\$-\$ uu----.

Before using your Omni-Reader you will need the following:-

a. A computer system/word processor with a serial communications port (RS232C or RS423A).

Fig. 2.

TET SHEET: Read this first and retain for future reference

OMNI-READER by OBERON INTERNATIONAL LTD

This test sheet, in conjunction with your user manual, will provide all the information you will need to start using your Omni-Reader. If you have any problems, consult your manual in greater detail.

1. Before using your Omni-Reader you will need the following:-

,-----a. A computer system/word processor with a serial communications port (RS232C or RSd23A).

Fig. 3.

TEST SHEET: Read this first and retain for future reference

OMNI-READER by OBERON INTERNATIONAL LTD

This test sheet, in conjunction with your user manual, will provide at the infor?tion,you will ne;y to start usino Your Omni-Reader. If you have anY Problems, consult your manual in greater detail.

1. Before using your Omni-Reader you will need the following:-

a. A computer system/word processor with a serial

Fig. 4.

COURIER 10 is used extensively for general office correspondence.

COURIER 12 is a square serif design in the Elite family, similar to the 10

LETTER GOTHIC 12 is a typeface used mainly for report writing, and general

PRESTIGE ELITE 12 is used mainly for legal correspondence and

Fig. 5

This is a samFie of Pvestike Pica 72.
The quick brown fox, etc.

This is osample oi DccRatc.
Thcquick bvown fox, ett.

Th; ;s a sample of Art; san)2 on !0.
The qu;ck brown tox. etc.

Th's !s a samp)eof Avt!san)2 on 12, (')!te
The qu'ck brown (x; etc.

tTs ;? p samPl\$of Arc;san 12 on .,
The oujck brown fox, ecc.

Omni-Reader Test Samples (see text)

line spacing. In Fig. 2, the line spacing is better, but we have a few serious typos and “garbage” when handling the empty lines. Figure 3 was the best we could do using several scanning techniques, as well as a “POOR” reading mode built into the device. We’ve got the spacing reasonably good—only two extraneous dashes—but a handful of typos.

Using Oberon’s own *printed* illustrations, as shown in Fig. 4, the best “reads” were obtained from Courier 10. The 12-pitch fonts produced the most errors.

Although Oberon specifies only four fonts, we couldn’t resist trying other typefaces. As shown in Fig. 5, Oberon knows of what they speak because the copy from Prestige Pica, Delegate, and Artisan fonts are almost incoherent.

Conclusions

The real problem with Omni-Reader isn’t the few typos it generates—they can be easily corrected from the keyboard; rather, it is its operating speed, which is not just slow, but s—l—o—w. For example, a not-so-experienced typist entered 25 lines (one standard business page) of “almost perfect” copy into a word processor before the Omni-Reader could enter 10 lines, and the reader produced more errors than the typist.

Of course, the relative value of anything is how much it costs for what it does. An Omni-Reader package consisting of optical character reader, RS232 connector cable, software for the IBM PC or Apple Mac-Intosh, and a training certificate valid for on-site user training is priced at \$799. If a few correctable typos are acceptable for that particular application, then \$799 is certainly a budget price in today’s marketplace. Nonetheless, it is still a handsome investment for a process that has its present shortcomings, though the technology, its promise and its relatively modest price are appealing **ME**

All About Telephones and How to Repair Them

A look at telephone repair

By TJ Byers

Last month, in Part 1 of this article we examined the telephone system as it exists today and the ways to troubleshoot it. This month, our focus is in how to correct problems that develop within the telephone instrument itself. Before we do this, however, you should know the basic elements that make up the typical telephone.

The modern-day telephone consists essentially of five parts. These are the ringer, the dialer, the hook-switch, the handset and the network. The most frequent failures occur in the ringer and dialing sections. Let's begin our discussion with the ringer section.

Ringer Problems

The basic ringer detects the nominal 86-volt, 20-Hz ac signal the phone company delivers to a subscriber's line when a call is coming in. It does so in a uniquely simple way. A bell-type telephone ringer consists of a coil of wire to which is attached a pivoting metal bar with a clapper at its end. One or two bells are mounted near the clapper. When the low-frequency ac current flows through the coil, the metal bar is attracted by the electromagnetic field, causing the clapper to strike the bell(s) 20 times each second.

A 0.5-microfarad capacitor wired in series with the coil (Fig. 4) isolates the bell coil from the dc portion of the circuit. This capacitor blocks dc but passes the ac that energizes the ringer

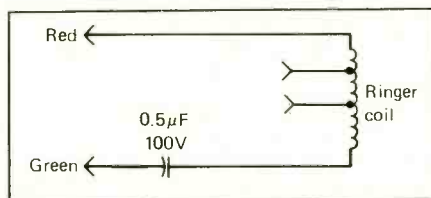

Fig. 4. A 0.5- μ F capacitor in series with the coil isolates bell from dc portion of the circuit.

when a ring signal is present. It's this capacitor that's the most frequent cause of ringer failure, usually by becoming an open circuit. When this occurs, the only remedy is to replace the capacitor. Because the capacitor is an integral part of the terminal board and is not normally accessible the only effective "repair" can be made by jumpering an external capacitor across the proper terminal con-

nections (see Fig. 5). Use a metal-film capacitor rated at 100 or more working volts.

A capacitor rarely shorts, and the coil just as rarely fails. However, if you suspect either condition, remove the coil wires from the terminal board and measure the components with an ohmmeter. Replacement is the only cure if your suspicions are borne out.

Electronic Ringer

Solid-state technology is rapidly making the electromechanical bell ringer a thing of the past. Replacing the bells is the electronic tone ringer (a beeper, a chirper or whatever). Electronic tone ringers can take many forms, but the most common is a piezoelectric transducer driven by an electronic oscillator.

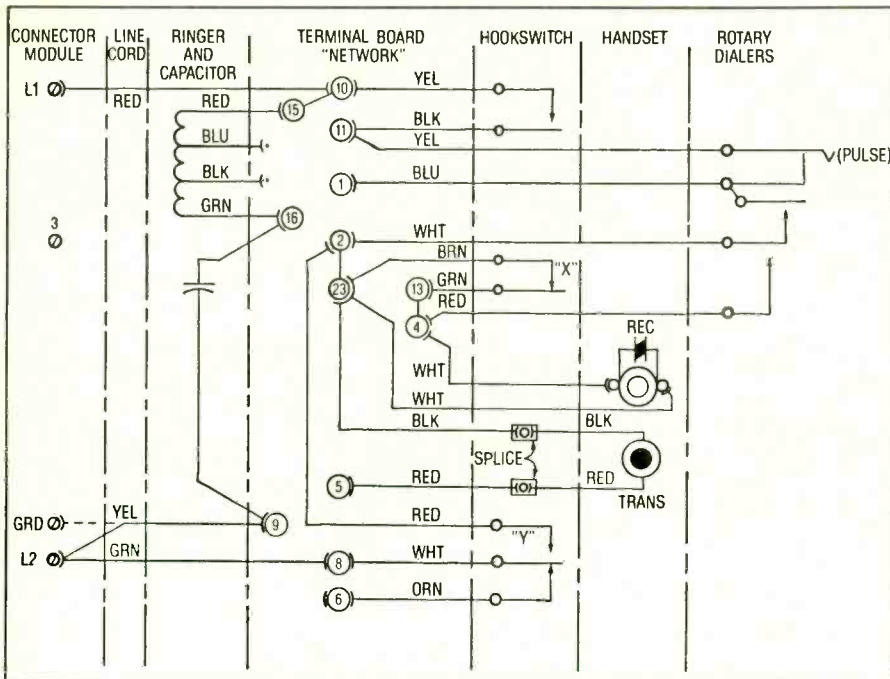

Fig. 5. This is the schematic diagram of a traditional telephone instrument. Included is the terminal board nomenclature.

circuit conditions. Oscillator output can be monitored with a signal trace or substitute transducer. Make sure all tests are performed with the phone removed from service.

Rotary Dialers

Most prevalent of telephone problems are those that occur in the dialer, especially in the case of the mechanical rotary dialer. An amazing achievement of mechanical engineering, the rotary dial is an intricate assembly that rapidly opens and closes a set of contacts connected across the phone line to produce a string of pulses that the phone company interprets as calling numbers.

As you turn the dial, a spring winds and an auxiliary set of shunt spring contacts are activated. The shunt springs short the handset to prevent the pulsing from being heard in the earphones. When the dial is released, a ratchet engages a cam that actuates pulser contacts. Dial speed is maintained at a constant 10 pulses per second by a mechanical governor.

The ratio of time that the pulser contacts are open to being closed is critical for proper dialer operation. This ratio is 61 percent, or 0.61-sec-

Integrated circuits are normally used with electronic ringers to detect the ring voltage and drive the piezoelectric element. The Motorola MC34017 is typical of electronic tone ringer chips. As Fig. 6 shows, the MC34017 is a complete ring detector circuit and oscillator in a single 8-pin DIP package. Power for the chip is taken from the telephone line by rectifying the ac ring signal using an internal full-wave rectifier and zener-diode voltage regulator.

To isolate the tone ringer from the voice part of the circuit, the chip uses a series capacitor/resistor combination that connects to the line. The ring tone is set by C2 and R2, while C3 and R3 form a filtering circuit that rejects false triggers.

In normal operation, C1 blocks dc from entering the IC, but when ac exceeding 36 volts appears on the line, current passes through it and into the chip's power supply. Application of power to the internal relaxation oscillator then produces a tone that's buffered to the piezoelectric device.

Failure of an electronic tone ringer can often be traced to the transducer

or the chip itself. The circuit can be tested by securing the hookswitch in the off position (on-hook) and applying a 60-Hz signal from a Variac, adjusted to 60 volts across the input line. The Variac provides a steady input signal that allows you to take voltage measurements and monitor

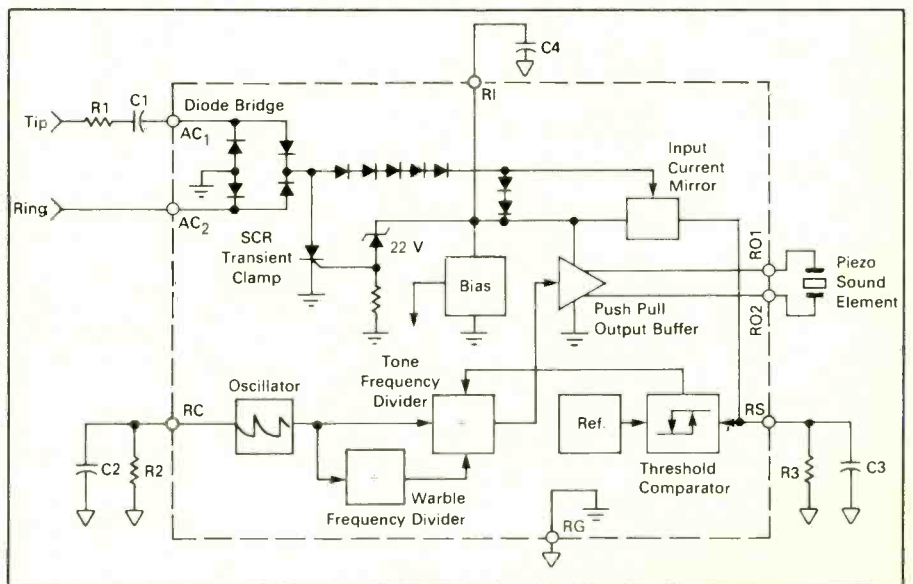

Fig. 6. The MC34017, a complete ring detector circuit and tone generator in a single 8-pin DIP package, replaces the bulky electromechanical bell.

ond open and 0.039-second closed. Each 100-millisecond (0.100-second) period represents a dial pulse, and each pulse represents a part of a number. The number of pulses in a continuous train is the same as the number of the digit dialed. For example six pulses are generated when the 6 key on the keypad is pressed, and 10 pulses are generated when the 0 (Operator) key is pressed.

Most residential telephones in the U.S. still use mechanical pulse dialers. Since mechanical elements are much less reliable than are all-electronic devices, this explains why dialing problems are the most frequently encountered.

Repairing a rotary dialer is no easy task. Pulse rate and dwell time are determined by spring tension and mechanical spacing inside the dialer. In the case of the pulse rate, the mechanical governor uses spring tension to control "fly-away" weights used to slow down the return of the dial. Too little spring tension on these counterweights, and the dialer pulses too slowly; too much, and it returns too quickly.

Dwell time is determined by the gap between the pulser contact points in relationship to the cam angle. It's set by a procedure very similar to the setting of points in a car and is just as tricky to perform.

Dwell time can also be altered by both contact resistance and contact tension, in addition to the point gap, so check all possibilities. Pulse rate is less critical, and may vary by as much as 100 percent (up to 21 pulses per second) in many exchanges.

Electronic Pulse Dialers

VLSI (Very Large Scale Integration) IC circuits and pushbutton keypads have made the pulse dialer more reliable. In place of the rotating cam and pulser contacts, the new ICs place digital pulses directly on the telephone line electronically.

There are many different types of pushbutton pulse dialers, but all function the same. A representative

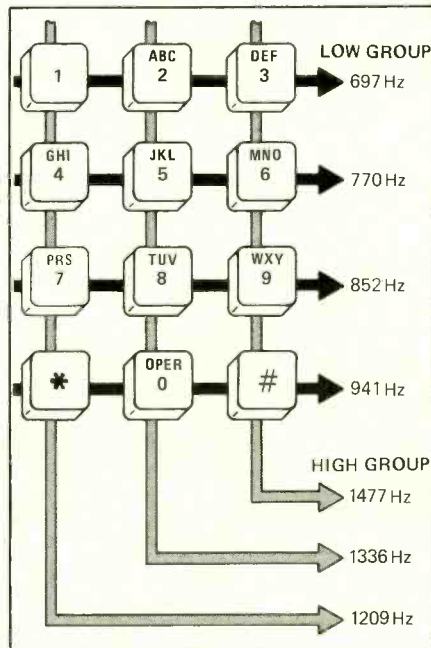

Fig. 7. A block diagram of a typical electronic pulse dialer.

block diagram is shown in Fig. 7. The keypad logic changes a 3-by-4 push-button matrix input into a series of output pulses that corresponds to the numeral key pressed. The pulse train is timed exactly the same as the rotary dial, with 61 and 39 milliseconds of off and on times, respectively. At least 750 milliseconds of delay is inserted between pulse streams (numbers) to avoid run-on.

Most of us can punch buttons faster than the dialer can output pulses, though, so the chip contains a memory feature. When a number is entered, it's stored in a memory register inside the chip. As the pulses are outputted, the chip recalls these numbers from memory in the same sequence in which they were entered. This is what makes possible the automatic-redial function found in many modern telephones. Since the telephone number last dialed remains in memory, a single keystroke can recall it. Because of this, most electronically pulsed phones have this feature.

Very little can go wrong with an electronic pulse dialer, other than failure of the chip. Almost all functions are contained within the chip it-

self—with the possible exception of the power supply.

Digital dialers derive power from the 50-volt telephone line. In most cases, the diodes needed to steer the source voltage aren't inside the chip. They're found as discrete components on the printed-circuit board, usually within easy reach of the hookswitch.

Should one of the diodes fail, strange things can—and do—occur. There are four diodes, usually of the 1N4000 series, arranged as a full-wave bridge rectifier. This configuration doesn't change ac into dc; rather, it steers the positive and negative lines so that the telephone isn't polarity sensitive. So if your automatic pulse dialer isn't working, the first thing to check are the diodes.

Touch Tone Dialing

Touch Tone is a signaling system that's rapidly replacing the rotary dial and holds the promise of expanded services for the future. Technically defined as Dual-Tone Multi-Frequency (DTMF) communications, Touch Tone offers increased speed and the ability to communicate data.

Instead of sending groups of pulses to the central office, Touch Tone transmits pairs of tones to the central exchange, where they're deciphered by special receiving equipment. Because the DTMF tones are in the audio range, two tones are used to distinguish between actual signaling and voice. Tone signaling is based on an internationally accepted standard of frequencies that includes four tones of a lower register and three of a higher frequency. All digits are derived by combining one low group frequency and one high group frequency, as illustrated in Fig. 8. DTMF tones are sent with a minimum duration of 50 milliseconds and interdigit time of 45 milliseconds.

The tone frequencies must be accurate to within 1.5 percent of their stipulated value under all conditions of temperature and voltage through-

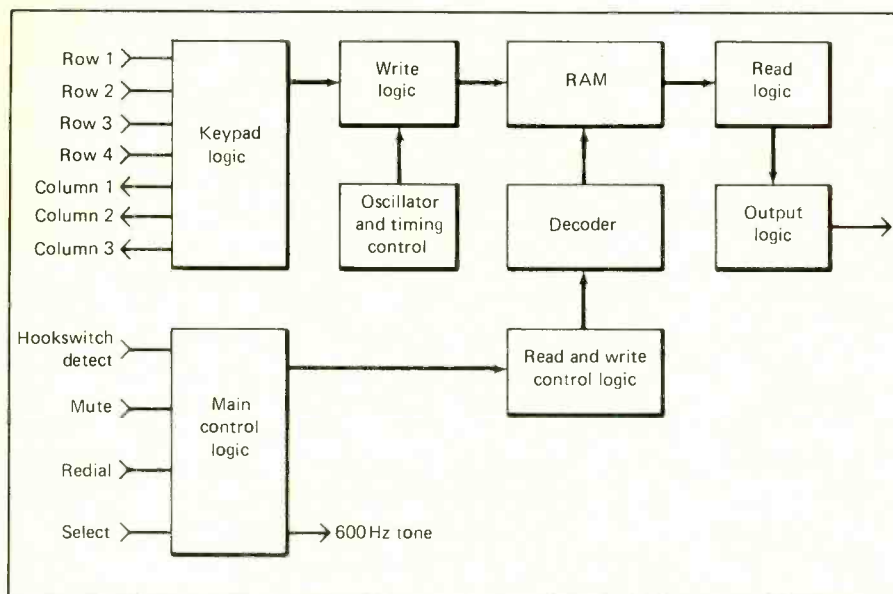

Fig. 8. Touch Tone dialing uses tones instead of pulses for transmitting numbers and data. All 10 digits and two special-purpose keys are represented by combining one low group and one high group frequencies to form a DTMF tone.

out the life of the telephone. Touch Tone dialers manufactured by Western Electric (a subsidiary still retained by AT&T) uses a single transistor LC oscillator to achieve the stability necessary for DTMF. The inductors used for the oscillator are multi-tapped for different impedance values.

Touch Tone pushbuttons are mechanically connected to 11 sets of gold-plated contacts. Pressing any one button actuates seven of the 11 contacts, causing a different inductance to be inserted into the oscillator circuit, and a different pair of tones to be generated. Five contacts are sealed in a clear plastic dust cover and seldom, if ever, need servicing. The remaining six are located around the upper perimeter of the Touch Tone keypad, occasionally giving trouble. The trouble usually appears as a single tone instead of the normal two. Repair is simple: clean the contacts, using only nonabrasive chemical cleaners—*never* sandpaper.

The inductors are slug tuned, using a triangular alignment tool. One inductor tunes the high range, the other the low range. Always use a frequency counter when adjusting these coils.

Recently, telephones have been introduced that include all the electronics necessary for a reliable DTMF system on a single chip. Like pulse dialer ICs, the DTMF circuits decode a keyboard input and translate it into dual-frequency tones. Failure of this design can almost always be attributed to power supply, DTMF chip, or keypad, in that order. Use the techniques outlined above for troubleshooting.

Voice Processing Networks

There are three parts to the voice circuit. They are the hookswitch, the handset and the network. The hookswitch is that part of the circuit that determines if the phone is on-hook (out of service) or off-hook (in use) and is the device that actually connects the microphone and speaker across the line. The switch is sealed inside a dust-proof plastic box and seldom causes problems. If problems do arise, they can normally be cured by thoroughly cleaning the contacts with a chemical cleaner.

In electronic telephones, the hookswitch may be nothing more than a simple spst microswitch that con-

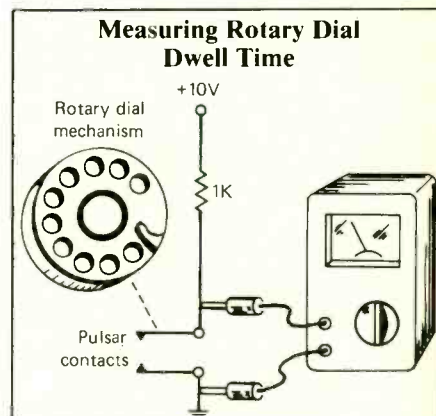

Schematic of electronic telephone.

The ratio of the time the pulsar's contacts are open to the time they're closed is easily measured using a power supply and a multimeter as follows. Connect a 10-volt power supply in series with the pulsar's contacts and a resistor shown above and monitor the voltage across the contacts. The voltage displayed by the meter is proportional to the dwell time, with a 10-volt reading representing 100%. Any fractional part of 10 volts gives a percentage reading that requires only proper location of the decimal point. For example a 6-volt reading translates to 60%, a 5.5-volt reading translates to 55%. Ideally, the reading should be 6.1 volts, which translates to 61%.

nects an input transformer (and related circuitry) across the line. A jumper wire or ohmmeter can easily spot a defective hookswitch.

The next component is the handset. Time was when the handset was a unit on its own, apart from the main body of the telephone and tethered with a coiled cord. Today, we see more and more integration of the telephone itself into the handset, as witnessed by the trend in one-piece telephones.

Other than occasional failure of a microphone or speaker, little can be said about this part of the telephone. Traditional handsets have removable cups that allow for easy replacement of defective elements. One-piece designs must be dealt with accordingly. More and more, electret mike ele-

(Continued on page 91)



An Audio Step Generator

This project takes the tedium out of making frequency-response tests on audio equipment

By Jack Cunkelman

Running a frequency-response check with an audio signal generator can be quite a chore. A signal generator being the kind of instrument it is, you spend a lot of time just adjusting level controls. The greater the number of points to be plotted in a test, the more time you spend on monitoring signal levels and making adjustments. The Audio Step Generator described here is an ideal way around this problem. It automatically selects a series of frequencies and maintains a constant output level, letting you concentrate on the frequency-response test instead of on the test conditions.

Using a combination of analog and digital techniques, the Audio

Step Generator automatically steps through 10 frequencies of your choice while maintaining an output level that is constant within 0.5 dB over the entire 20-Hz to 20-kHz range. In addition, sine-wave signal distortion is good enough to suit the needs of most users who do not require laboratory precision.

About the Circuit

The Step Generator is built around function generator integrated circuit *IC1* in Fig. 1, selected for this application because of the ease with which the frequency can be changed. Ordinarily, function generator chips do not produce low-distortion sine waves. However, the XR2206 chosen for *IC1* here provides a 0.5% distortion figure, which is acceptable in all

but critical applications. Potentiometers *R1* and *R2* are used to adjust distortion of *IC1* to a minimum.

While it is possible to generate a sweep frequency output from a function generator, the ability to determine the frequency at any given instant is lost by doing so. Hence, it was decided that 10 discrete frequencies that could be stepped through would be used. Capacitor *C1* and the resistor connected to pin 7 of *IC1*, which we will refer to as *R_X* but is actually identified in Fig. 1 as *R9* through *R18*, determine the frequency of oscillation from the formula $f_0 = 1/(R_X \times C1)$, with f_0 in Hz, R_X in ohms and *C1* in farads.

Though the value of either *R_X* or *C1* can be varied to change the frequency, it is easier to fix the value of the capacitor and vary that of the resistor in steps. The Table lists various frequency and resistor values needed to generate these frequencies. Trimmer potentiometers or fixed resistors can be used for *R_X*, depending on the frequency accuracy you require. A Mylar or polystyrene capacitor for *C1* will provide maximum stability. If you use a 5% tolerance capacitor, the frequencies will be more accurate when using fixed resistors.

When pin 9 of *IC1* is open, *R_X* determines the frequency of oscillation. Grounding pin 9 makes *R6* the frequency-determining element. This feature is used to provide a SET LEVEL position in the project to permit setting initial levels before starting a frequency run, using *S1* to switch this function on and off.

Various values for *R_X* are switched in with the *IC3*, *IC4* and *IC5* CMOS switches. The switches are turned off and on by divide-by-10 counter *IC2*. Two NAND gates in *IC6* are wired as an oscillator to drive counter *IC2*. This oscillator sets the rate at which the frequencies are switched. The pulse output rates of this oscillator are determined by the *R7/C5* time constant. Using an audio taper for potentiometer *R5* permits the rate adjustment to be spread out over the

PARTS LIST

Semiconductors

- D1 thru D4—1N4005 rectifier diode
- IC1—XR2206 function generator
- IC2—4017 counter
- IC3 thru IC5—4066 CMOS switch
- IC6—4011 quad NAND gate
- IC7—NE5532 dual op amp
- IC8—7815 +15-volt regulator
- IC9—7915 -15-volt regulator
- LED1—Light-emitting diode

Capacitors

- C1—0.033- μ F, 5% Mylar
- C2 thru C4—22- μ F, 25-volt electrolytic
- C5 thru C7—47- μ F, 16-volt electrolytic
- C8, C9—10- μ F, 25-volt electrolytic
- C10, C11—2200- μ F, 25-volt electrolytic

Resistors (1/4-watt, 10% tolerance)

- R4, R5—5600 ohms
- R6—See table
- R8—2200 ohms
- R9 thru R18—See table
- R20, R23—4700 ohms
- R21, R22—100,000 ohms
- R24 thru R27—300 ohms
- R1—500-ohm trimmer potentiometer
- R2—25,000-ohm trimmer potentiometer
- R3—50,000-ohm trimmer potentiometer
- R7—100,000-ohm audio-taper potentiometer
- R19—50,000-ohm audio-taper potentiometer

Miscellaneous

- F1—1/4-ampere slow-blow fuse
 - S1—Dpdt switch
 - S2, S3—Spst switch
 - T1—30-volt, 500-mA center-tapped transformer
- Printed-circuit board, perforated board and solder posts, or large solderless socket (see text); sockets for ICs; panel-mount, bayonet-type fuse holder for F1; suitable chassis box (LMB No. CR864 or similar); control knobs (2); output connectors; line cord with plug and strain relief; machine hardware; hookup wire; solder; etc.

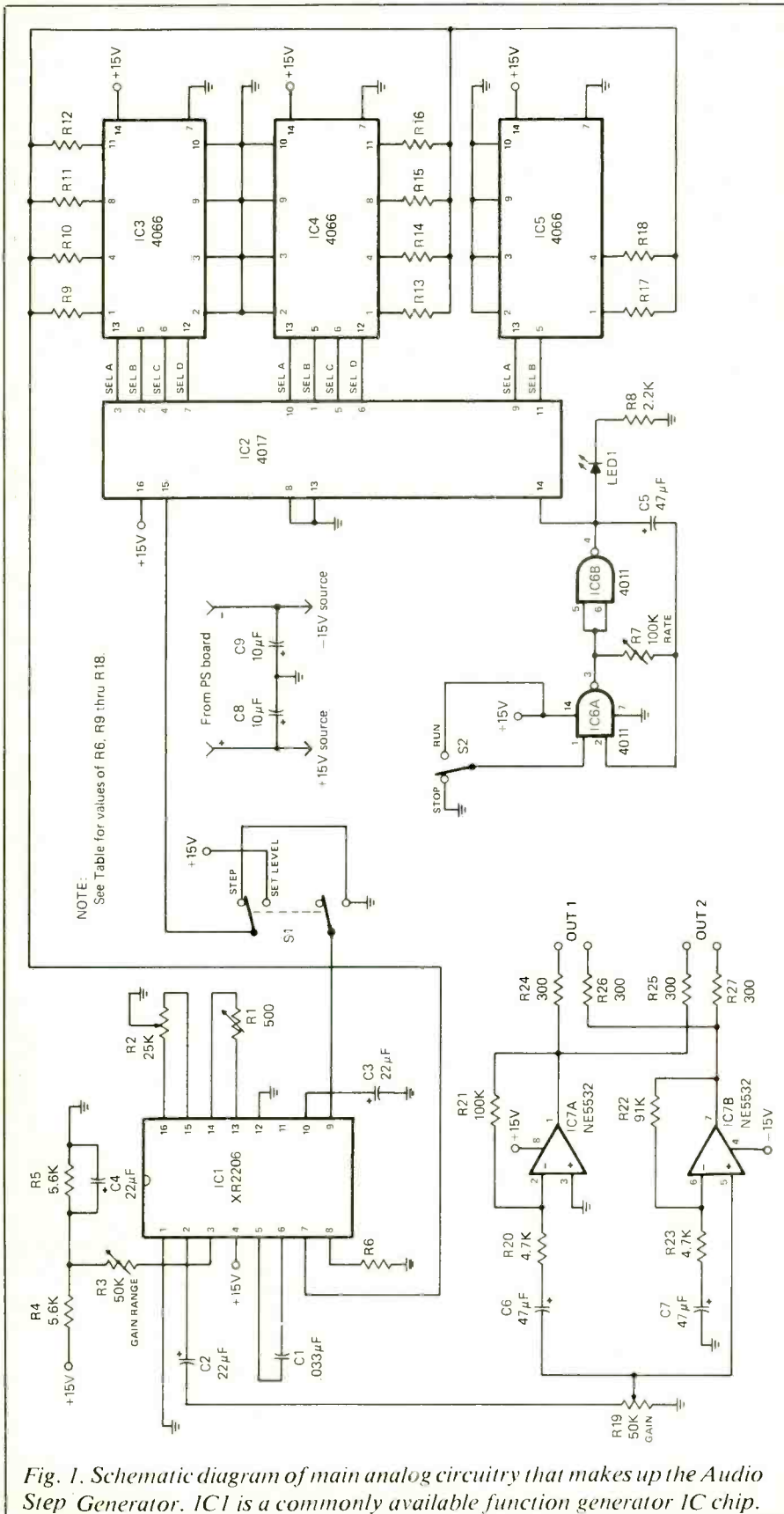

Fig. 1. Schematic diagram of main analog circuitry that makes up the Audio Step Generator. IC1 is a commonly available function generator IC chip.

entire range of the pot. When pin 1 of IC6A is high, the oscillator is enabled. Pulling pin 1 to ground disables oscillation. This is the RUN/STEP function. Its condition is determined by the setting of S2. When power is on, the frequencies are changed each time LED1 goes from off to on.

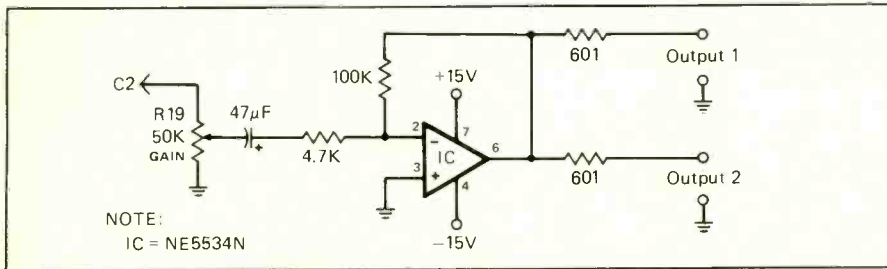

Fig. 2. This alternate output circuit provides outputs that properly match 600-ohm unbalanced inputs.

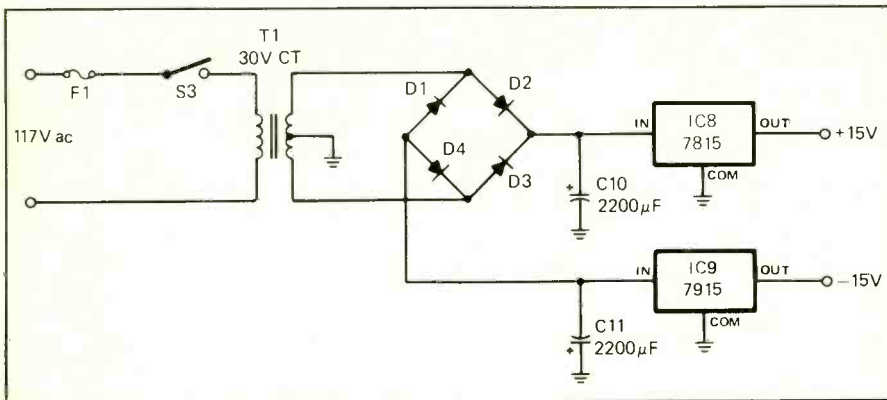

Fig. 3. This is the schematic diagram of the power supply used with the Step Generator's circuitry.

The output from this oscillator is fed into the clock input of counter IC2. The counter advances each time the clock pulse goes from ground to positive. As the counter advances, each of the 10 outputs is made positive, one at a time, in step fashion. The reset pin is normally at ground by setting S1 to the STEP position. Throwing S1 to the SET LEVEL position resets the counter to 0 and "sets" the function generator to its fixed frequency position. Thus, going from SET LEVEL to STEP always starts at the same spot.

The outputs of counter IC2 drive the control terminals of analog switches IC3, IC4 and IC5, which in turn switch in various values for R_X . When a control pin is made high, the switch is on. (The analog switches have an on resistance of approximately 100 ohms.)

Output buffer amplifier IC7 contains a pair of high-performance operational amplifiers that provide bal-

anced 600-ohm outputs. Inverting amplifier IC7A's input and output are 180 degrees out-of-phase, while buffer IC7B's input and output are in-phase with each other. Using one output from IC7A and one from IC7B yields a balanced output. Output impedance is fixed at 600 ohms by R24 and R26 for OUTPUT 1 and by R25 and R27 for OUTPUT 2. With two outputs available, you can check both channels of a stereo amplifier simultaneously.

In Fig. 2 is shown a scheme to derive two unbalanced outputs. Only one amplifier is needed in this case. Output impedance is determined by the values of the resistors in series with the output. These values can be changed as needed.

As shown in Fig. 3, the power supply for the project is relatively simple. Its 30-volt center-tapped transformer feeds a four-diode bridge whose output is filtered by two capacitors and is regulated at +15 and

-15 volts with separate IC regulators. (A 24-volt center-tapped transformer and 12-volt regulators could be used, but maximum output from the project would be less.)

Construction

There is nothing critical about construction. Just be sure to keep the ac line and power supply proper as far as possible from the analog circuits. Any reasonable method of wiring the project can be used—a printed-circuit board of your own design, perforated board and solder or Wire Wrap hardware or even a large solderless breadboarding socket.

It is a good idea to socket all ICs except the regulators. As you wire the project, referring to Figs. 1 and 3, be sure to observe proper orientations for the ICs and polarization of electrolytic capacitors and diodes.

Fig. 4 shows the Step Generator's analog circuitry wired on a 4" x 4" perforated board with the aid of appropriate mounting/soldering hardware. The power supply section (Fig. 5) was assembled on a separate 4" x 2" perforated board. Because current drain is quite low, no heat sinks are required for the regulators.

The project fits nicely into an 8" x 6" x 4 1/2" chassis box. This size box assures ample front panel area for the controls, switches and LED, as well as enough interior space to insure isolation of the power supply from the main analog board.

Machine the chassis box as required. Drill holes for the controls, switches, output connectors and LED on the front panel, and the power supply board, power switch, power transformer, fuse holder and line cord on the rear panel. The analog board mounts on the floor of the box, as far forward as possible without interfering with the front-panel components.

Mount the power supply board on with 6-32 machine hardware and spacers. Mount the power trans-

C.O.M.B. BREAKS THE SATELLITE TV PRICE BARRIER! KLM 8-ft. SATELLITE TV RECEIVER SYSTEM HIGH PERFORMANCE! TOP NAME BRAND!

FACTORY NEW! FIRST QUALITY!

COMPLETE, PERFECTLY MATCHED SYSTEM!

- Designed for do-it-yourself installation!
- Fully programmable location of each satellite!
- All motorized!
- Automatic push-button selection of each satellite!
- Includes 120 feet of cable!
- Superior quality throughout!



REMOTE CONTROL
Operates Aimer IV (shown at right). Push-button access to 64 programmed satellites. 6 pre-sets for your favorite programs.

Does not include metal support pipe.

It opens up a vast new world of TV entertainment! MORE sports! MORE movies! MORE of everything you like to watch! And it provides superior reception capabilities!

The KLM 8-ft. Satellite TV Receiver system picks up signals from more than a dozen communications satellites in the sky. This opens up over 100 channels of TV viewing, with a multitude of programs. And the KLM system provides outstanding reception capabilities throughout the entire 48 states!

PERFECT FOR SPORTS FANS! Enjoy much more sports action and thrills than ever before! You'll literally be "in heaven" with the vast selection of football, baseball, basketball, hockey and many other exciting televised sporting events to choose from.

HUGE VARIETY OF ENTERTAINMENT. Watch popular new films and plenty of classic "oldies" on the movie channels. Keep up with fast-breaking national and international events, any time of day, on all-news networks.

Get important investment "tips" and information from the financial/business channels. View provocative Adults Only programs. Delight in video entertainment of top performers on music channels for rock, pop, country, classical, etc.

PLUS, there are entertaining and educational channels specifically for children. Religious and cultural channels. French and Spanish networks. The list goes on and on! And with each new TV satellite placed in the sky, your exciting world of home entertainment keeps growing LARGER and LARGER!

IDEAL FOR RURAL AREAS! If TV reception is poor or the variety is very limited where you live, you're in for a HUGE DELIGHT! With the KLM system, reception is as good as in a big city. And the variety is huge!

GREAT FOR URBAN AND SUBURBAN AREAS! With the KLM system, you can still pick up all your usual local stations. PLUS, you get greatly expanded selection from all the satellite channels. There's a huge world of viewing pleasure in store for you. Up to 100 or more TV channels are available with the KLM system!

DO-IT-YOURSELF INSTALLATION! You don't have to be an electronics "whiz" to install the KLM system. Components come pre-assembled, except for the 8-ft. "dish." Need: 3/2" outside dia. support pipe, bag of cement mix and your own TV. KLM has a Toll-Free number to call just in case you need assistance. The "dish" is designed to withstand high winds.

AN EXCELLENT VALUE! Don't be fooled by someone else's "low" price on a "dish" that is SMALLER than ours... NOT as high-tech... or is INCOMPLETE and requires costly purchases of additional components. With our KLM 8-ft. "dish" you get a complete, superior quality system from a leader in the industry... at a remarkably low closeout price!

One year limited factory warranty on parts and labor.

Mr. Suggested List Price **\$1900.00**
ENTIRE SYSTEM Closeout Price **\$999**

Item H-1126-5958-004
F.O.B. Milwaukee, Wisc. metro area
Shipping, weight, approx. 155 lbs.

FREE WITH YOUR ORDER. Current issue of SATELLITE ORBIT magazine! PLUS money-saving subscription offer of 15 issues for the price of 12. Each issue packed with over 200 pages of monthly listings for thousands of satellite TV programs to select from.

ABOUT THE MANUFACTURER

KLM introduced the FIRST satellite TV receiver system for consumers! They designed the FIRST programmable receiver. KLM is one of the largest in the industry and is a leader in advanced technology. Because they are concentrating efforts on new designs, KLM has allowed us to offer a quantity of these current 8-ft. models to the public at an unusually low price! It's a tremendous value!

INCLUDES ALL THIS, TOO!



SKY EYE X BLOCK RECEIVER!

Uncomplicated, easy operation! Fast fingertip selection of channel, polarity, audio tune. Relative signal strength meter lets you hit station right on the button. Separate AFC on/off selector allows precision tuning, even of weak channels.

INCLUDES blackout converter (an expensive option on competitor's models). This splits signals so 2 TV sets in your home can "tune in" on 2 different channels of same satellite at same time. However, you need another receiver (available from regular KLM dealers) for the second TV set.

HORIZON TO HORIZON MOUNT

This special mount delivers maximum degrees of "dish" rotation for access to TV Receive Only satellites in western hemisphere. 120 feet of cable also included.



Fully Programmable AIMER IV REMOTE "DISH" POSITIONER

Microprocessor controlled for pushbutton access to 64 pre-programmed satellite locations. Six pre-sets for favorite satellites. Automatically positions "dish" and channel skew (polarity). Battery backup for three-month memory retention in case of power failure or for unplugging system during vacations. Parental Lockout prevents children from viewing restricted channels.

HOW TO SELECT A PROPER SITE

Stand on your yard, look due South, raise your head about 40°, move only your eyes from side to side. You should have an unobstructed view of the sky. Tree branches and power lines diminish quality of reception.

Credit card customers can order by phone, 24 hours a day, 7 days a week.



Toll-Free: 1-800-328-0609

Your check is welcome! No delays in orders paid by check.

Sales outside continental U.S. are subject to special conditions. Please call or write to inquire.

C.O.M.B. Direct Marketing Corp. Item H-1126
14605 28th Ave. N. / Minneapolis, MN 55441-3397

Send KLM 8-ft. Receiver System(s) Item H-1126-5958-004 at \$999 each. I will pay shipping charge to driver upon delivery. (Minnesota residents add 6% sales tax. Allow 4-5 weeks for delivery. Sorry, no C.O.D. orders.)

My check or money order is enclosed. (No delays in processing orders paid by check, thanks to TeleCheck.)

Charge to my MasterCard® VISA®

Acct. No. _____ Exp. _____

PLEASE PRINT CLEARLY

Name _____

Address _____

City _____

State _____ ZIP _____

Phone (____) _____

Sign Here _____

C.O.M.B. DIRECT MARKETING CORP.

Authorized Liquidator

14605 28th AVENUE NORTH
MINNEAPOLIS, MN 55441-3397

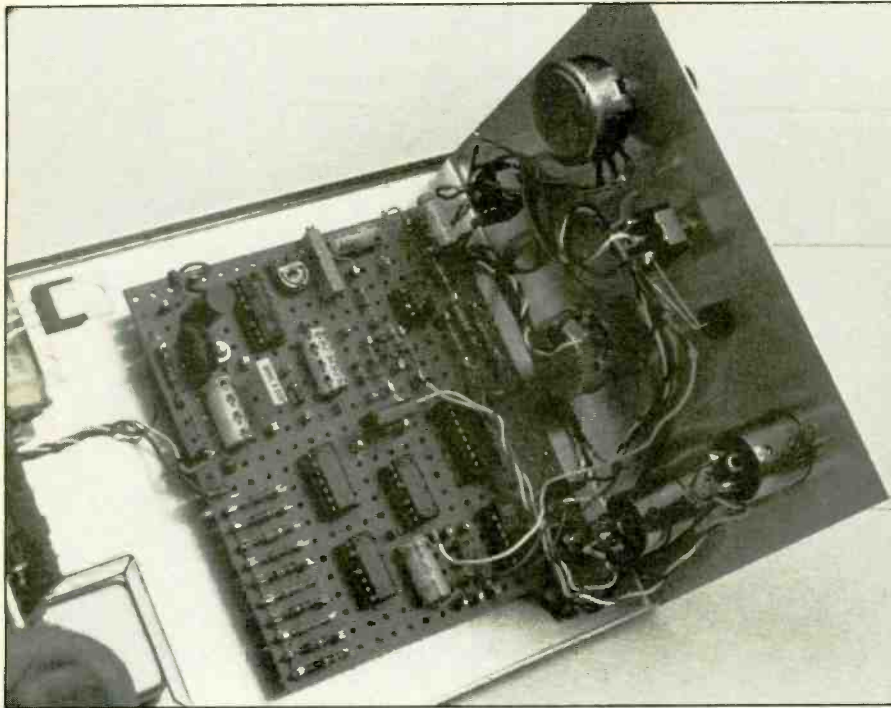

Fig. 4. This view shows analog circuit board layout on perforated board and front-panel component mounting details. ICs are in sockets.

former and the fuse holder. Use a strain relief to secure the line cord in place about 4" from its free end inside the box. Alternatively, line the remaining hole with a rubber grommet and pass the line cord through in-

to the box and tie a knot, leaving about 4" of wire inside the box.

Connect and solder one of the transformer's primary leads to one lug of the power switch and a short heavy-duty stranded hookup wire

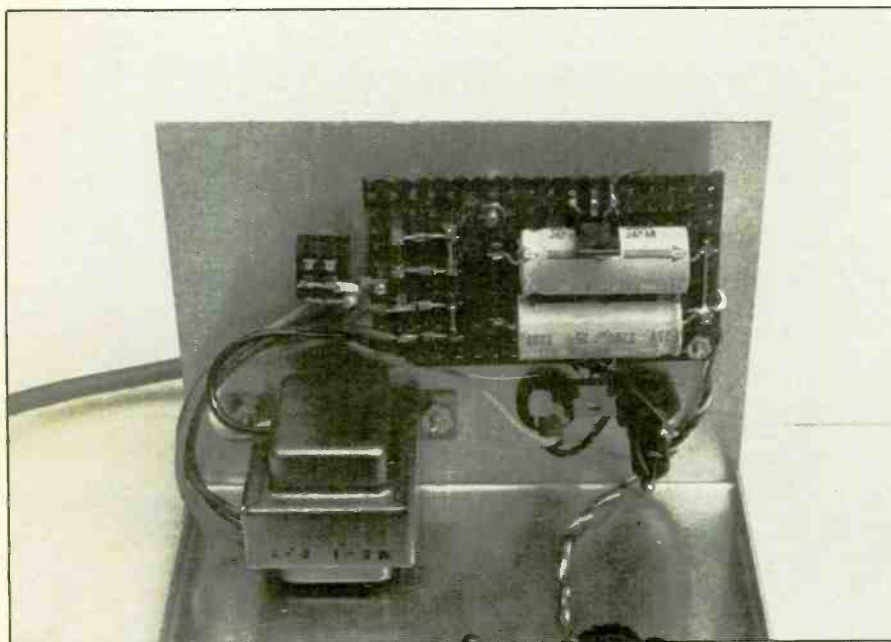

Fig. 5. Power supply board, transformer, fuse holder and power switch mount on rear panel. Secure the line cord as explained in the text.

Resistor Values

Frequency (Hz)	Value (ohms)	Frequency (Hz)	Value (ohms)
20	1.515M	8k	3637
40	757.42k	10k	2880
80	378.64k	12k	2375
100	302.88k	14k	2014
400	75.607k	16k	1743
800	37.728k	17k	1632
1k	30.153k	18k	1533
2k	15.000k	19k	1444
4k	7425	20k	1365
6k	4900		

Resistor values for some typical frequencies. Select 10 frequencies that best suit your needs. The values shown in this table were selected for a 0.033- μ F value for timing capacitor C1.

from the other lug of the power switch and one lug of the fuse holder. Connect and solder one line cord wire to the remaining lug of the fuse holder. Though Fig. 3 does not show it (the photo in Fig. 4 does), you can use the second pair of contacts of a dpdt switch to make and break the lower line in the transformer primary circuit simultaneous with the make/break action of the fused line. If you do, connect and solder the other line cord wire to one lug of the second switch section and the remaining transformer primary lead to the other lug. Otherwise, twist together the line cord wire and primary lead and screw onto the connection a wire nut.

Mount the front-panel components and the analog circuit board on the floor of the box. Referring to Figs. 1 and 4, carefully wire the controls, switches and LED into the circuit. When you are finished wiring the project, carefully go over all your wiring, particularly in the power supply, to make sure that everything is okay before you power the project.

Adjustment and Use

Set all controls to mid-rotation and

Super Disk™ Diskettes

Now...Diskettes you can swear by, not swear at.

Lucky for you, the diskette buyer, there are many diskette brands to choose from. Some brands are good, some not as good, and some you wouldn't think of trusting with even one byte of your valuable data. Sadly, some manufacturers have put their profit motive ahead of creating quality products. This has resulted in an abundance of low quality but rather expensive diskettes in the marketplace.

A NEW COMPANY WAS NEEDED AND STARTED

Fortunately, other people in the diskette industry recognized that making ultra-high quality diskettes required the best and newest manufacturing equipment as well as the best people to operate this equipment. Since most manufacturers seemed satisfied to give you only the everyday quality now available, an assemblage of quality conscious individuals decided to start a new company to give you a new and better diskette. They called this product the *Super Disk* diskette, and you're going to love them. Now you have a product you can swear by, not swear at.

HOW THEY MADE THE BEST DISKETTES EVEN BETTER

The management of *Super Disk* diskettes then hired all the top brains in the diskette industry to make the *Super Disk* product. Then these top bananas (sometimes called floppy freaks) created a new standard of diskette quality and reliability. To learn the "manufacturing secrets" of the top diskette makers, they've also hired the remaining "magnetic media moguls" from competitors around the world. Then all these world class, top-dollar engineers, physicists, research scientists and production experts (if they've missed you, send in your resume to *Super Disk*) were given one directive...to pool all their manufacturing know-how and create a new, better diskette.

HOW SUPER DISK DISKETTES ARE MANUFACTURED

The *Super Disk* crew then assembled the newest, totally quality monitored, automated production line in the industry. Since the manufacturing equipment at *Super Disk* is new, it's easy for *Super Disk* to consistently make better diskettes. You can always be assured of ultra-tight tolerances and superb dependability when you use *Super Disk* diskettes. If all this manufacturing mumbo-jumbo doesn't impress you, we're sure that at least one of these other benefits from using *Super Disk* diskettes will:

- TOTAL SURFACE TESTING** - For maximum reliability, and to lessen the likelihood of disk errors, all diskettes must be totally surface tested. At *Super Disk*, each diskette is 100% surface tested. *Super Disk* is so picky in their testing, they even test the tracks that are in between the regular tracks.
- COMPLETE LINE OF PRODUCTS** - For a diskette to be useful to you and your computer, it must be compatible physically. *Super Disk* has an entire line of 5 1/4-inch and 3 1/2-inch diskettes for your computer.
- SPECIALLY LUBRICATED DISK** - *Super Disk* uses a special oxide lubricant which is added to the base media in the production of their diskettes. This gives you a better disk drive head to media contact and longer head and disk life.
- HIGH TEMPERATURE/LOW-MARRING JACKET** - A unique high temperature and low-marring vinyl jacket allows use of their product where other diskettes won't work. This special jacket is more rigid than other diskettes and helps eliminate dust on the jacket.
- REINFORCED HUB RINGS** - Standard on all 48 TPI *Super Disk* mini-disks, to strengthen the center hub hole. This increases the life of the disk to save you money and increase overall diskette reliability.
- DISK DURABILITY** - *Super Disk* diskettes will beat all industry standards for reliability since they will give you more than 75% of the original signal amplitude remaining even after an average (Weibull B-50) of 30 million passes. They are compatible with all industry specifications as established by ANSI, ECMA, ISO, IBM and JIS.
- CUSTOMER ORIENTED PACKAGING** - All *Super Disk* disks are packaged 10 disks to a carton and 10 cartons to a case. The economy bulk pack is packaged 100 disks to a case without envelopes or labels.
- LIFETIME WARRANTY** - If all else fails, remember, all disks made by *Super Disk* Inc., have a lifetime warranty. If any *Super Disk* diskette fails to meet factory specifications, *Super Disk* Inc. will replace them under the terms of the *Super Disk* warranty.
- SUPERB VALUE** - With *Super Disk*'s automated production line, high-quality, error-free disks are yours without the high cost.

Order toll free 800-USA-DISK

NOW...NAME BRAND QUALITY AT SUPER CE PRICES

Now, you can buy *Super Disk* brand diskettes directly from Communications Electronics at prices less than "unbranded" generic diskettes. Your data is valuable, so why take chances using a diskette that could be so unreliable that the manufacturer refuses to put their name on it. To save you even more, we also offer *Super Disk* bulk product where 100 diskettes are packed in the same box without envelopes or labels. Since we save packaging costs, these savings are passed on to you. 5 1/4" diskette envelopes are also available from us. These super strong and tear-resistant envelopes are only \$10.00 per pack of 100. Use order # CV-5 for a 100 pack of 5 1/4" diskette envelopes.

39¢ per disk Quantity One

Our diskettes are packed 10 disks to a carton and 10 cartons to a case. The economy bulk pack is packaged 100 disks to a case without envelopes or labels. For best value, you should order in increments of 100 diskettes. Almost all diskettes are immediately available from *Super Disk*. With our efficient warehouse facilities, your order is normally shipped in less than a day.

SAVE ON SUPER DISK™ DISKETTES

Product Description	Part #	Super Disk price per disc (\$)
5 1/4" SSSD Soft Sector w/Hub Ring	6431-FA	0.64
5 1/4" Same as above, but bulk pack w/o envelope	6437-FA	0.39
5 1/4" SSDD Soft Sector w/Hub Ring	6481-FA	0.68
5 1/4" Same as above, but bulk pack w/o envelope	6487-FA	0.43
5 1/4" DSDD Soft Sector w/Hub Ring	6491-FA	0.74
5 1/4" Same as above, but bulk pack w/o envelope	6497-FA	0.49
5 1/4" DSQD Soft Sector (96 TPI)	6501-FA	1.09
5 1/4" Same as above, but bulk pack w/o envelope	6507-FA	0.84
5 1/4" DSHD for IBM PC/AT - bulk pack	6667-FA	2.07
3 1/2" SSDD (135 TPI) - bulk pack	6317-FA	1.67
3 1/2" DSDD (135 TPI) - bulk pack	6327-FA	1.99

SSSD = Single Sided Single Density; SSDD = Single Sided Double Density; DSDD = Double Sided Double Density; DSQD = Double Sided Quad Density; DSHD = Double Sided High Density; TPI = Tracks per inch.

BUY YOUR DISKETTES FROM CE WITH CONFIDENCE

To get the fastest delivery of your diskettes, phone your order directly to our order desk and charge it to your credit card. Written purchase orders are accepted from approved government agencies and most well rated firms at a 10% surcharge for net 10 billing. For maximum savings, your order should be prepaid. All sales are subject to availability, acceptance and verification. All sales are final. All prices are in U.S. dollars. Prices, terms and specifications are subject to change without notice. Out of stock items may be placed on backorder or substituted for equivalent product unless we are instructed differently. A \$5.00 additional handling fee will be charged for all orders with a merchandise total under \$50.00. All shipments are F.O.B. CE warehouse in Ann Arbor, Michigan. No COD's. Non-certified checks require bank clearance. Michigan residents add 4% sales tax or supply your tax ID number and reason for tax exemption.

For shipping charges add \$6.00 per 100 diskettes and/or any fraction of 100 5 1/4-inch or 3 1/2-inch diskettes for U.P.S. ground shipping and handling in the continental U.S. For 1,000 or more disks shipped to the continental U.S., shipping charges are \$4.00 per hundred diskettes. UPS 2nd day air rates are three times continental U.S. rates. For Canada, Puerto Rico, Hawaii, Alaska, or APO/FPO delivery, shipping is three times the continental U.S. rate.

Mail orders to: Communications Electronics Inc., Box 1045, Ann Arbor, Michigan 48106-1045 U.S.A. If you have a Visa or Master Card, you may call and place a credit card order. Order toll-free in the U.S. Dial 800-USA-DISK. In Canada, order toll-free by calling 800-CA1-DISK. If you are outside the U.S. or in Michigan dial 313-973-8888. Telex anytime 810-223-2422. Order your *Super Disk* diskettes now.

Copyright © 1986 Communications Electronics Inc.

Ad #040186-FA



**Now
39¢
a disk**

S1 to the SET LEVEL position. Connect an oscilloscope probe to the top of GAIN control *R19*. Plug in the Step Generator's line cord and turn on the power. While observing the oscilloscope display, adjust *R1* and *R2* for minimum distortion of the sine wave; *R1* adjusts for symmetry and *R2* adjusts for shape. You want a waveform with good rounding and symmetry. (If possible, use a distortion analyzer to adjust for minimum distortion. It should be possible to get the distortion down to 0.5% with trimmer potentiometers *R1* and *R2*.)

Move the scope's probe to one of the outputs of the buffer amplifier. Turn GAIN control *R19* fully clockwise and adjust *R3* until clipping is evident; then back off until clipping just disappears. This is the maximum output point. It should be about +22

dBm with a +15- and -15-volt power supply.

Operation of the Audio Step Generator is relatively straightforward. With *S1* in the SET LEVEL position, adjust the output level of the Generator to the level the device under test normally sees at its input. Then set *S1* to STEP and use *R7* to set the RATE at

which the generator steps through the frequencies. With STOP/RUN switch *S2*, you can stop the Generator at any frequency and then continue on. Whatever frequency is selected will be positioned between the highest and lowest frequencies to serve as a marker so that you can tell where the Generator is oscillating **ME**

Resistor Calculation

To calculate resistor values for a given frequency more accurately, you must obtain a more accurate value for timing capacitor *C1*. The following computer program will do this for you and then calculate the resistor values for any 10 frequencies you choose. For this procedure, you will need a good ohmmeter and a frequency counter (or oscilloscope). The program was written to run on an Apple II.

Your first objective is to accurately determine the value of *C1* as follows:

(1) Connect the frequency counter or oscilloscope to the Step Generator's input. If you are using a scope, set its sweep to external and apply a 60-Hz signal to the external input from a 6.3-volt filament transformer or other convenient signal source.

(2) Temporarily substitute a 250,000-

ohm potentiometer for *R6* on the Step Generator's main board. Connect either outer lug of the pot to one of the resistor connections and the wiper lug to the other resistor connection.

(3) Set the Step Generator to its SET LEVEL mode and adjust the potentiometer for a reading of 240 Hz on the frequency counter. If you are using a scope, the displayed Lissajous pattern should resemble two connected figure 8s lying on their sides when the pot is properly adjusted.

(4) Making sure not to disturb the potentiometer's setting, disconnect it from the circuit and measure the resistance between its wiper and the selected lug. Make a note of your reading, since it will be used later by the computer program to calculate the value of timing capacitor *C1*.

NEW FROM DON LANCASTER

HANDS-ON BOOKS

CMOS Cookbook	14.50
TTL Cookbook	12.50
TV Typewriter Cookbook	12.50
Active Filter Cookbook	14.50
Micro Cookbook vol I	15.50
Micro Cookbook vol II	15.50
Enhancing your Apple vol I	15.50
Enhancing your Apple vol II	15.50
Applewriter Cookbook	19.50
Apple Assembly Cookbook	21.50
Incredible Secret Money Machine	7.50

UNLOCKED SOFTWARE

Absolute Reset IIe & IIc	19.50
Applewriter Toolkit (Dos 3.3e)	39.50
Applewriter Toolkit (ProDOS)	39.50
Both Applewriter Toolkits	59.50
Applewriter/Laserwriter Utilities	39.50
Macintosh/Laserwriter Utilities	39.50
Laserwriter Demo Pack	FREE
Ram Card Disassembly Script	19.50
Appleworks Disassembly Script	49.50
Enhance vol I Companion Disk	19.50
Enhance vol II Companion Disk	19.50
Assembly CB Companion Disk	19.50
Classic Cell Animation Demo	12.50

FREE VOICE HELPLINE

VISA/MC

SYNERGETICS

Box 809-ME
Thatcher, AZ 85552
(602) 428-4073

CIRCLE 48 ON FREE INFORMATION CARD

```

3
3LIST
10 HOME
20 REM ** STEP GENERATOR
30 REM ** RESISTOR CALCULATION
40 INPUT "DO YOU WANT TO CALCULATE THE EXACT CAPACITANCE VALUE OF C1 (Y OR N) ?";A$
45 PRINT
50 IF A$ = "Y" THEN 90
60 IF A$ = "N" THEN 70
65 GOTO 40
70 INPUT "ENTER THE VALUE OF C1 (UF)";C
75 C = C * 1E - 6: PRINT
80 GOTO 130
85 PRINT
90 INPUT "INPUT RESISTANCE MEASUREMENT OF TEST POT (OHMS)";R
95 PRINT
100 C = 1 / (R * 240)
120 PRINT "EXACT VALUE OF CAPACITATOR C1 IS "C" UF "
125 PRINT
130 PRINT "INPUT THE 10 FREQUENCIES YOU WANT TO CALCULATE RESISTOR VALUES FOR (HZ)"
140 FOR Z = 1 TO 10
145 PRINT Z;
150 INPUT F;
160 R = 1 / (C * F)
170 F(Z) = F:R(Z) = R
180 NEXT Z
200 INPUT "DO YOU WANT PRINTER OUTPUT (Y OR N)";P$
210 IF P$ = "Y" THEN PR# 1: GOTO 240
220 IF P$ = "N" THEN 240
230 GOTO 200
240 HOME
250 PRINT TAB( 5)"FREQUENCY"; TAB( 20)"RESISTOR VALUE"
270 PRINT
280 FOR Z = 1 TO 10
290 PRINT Z;
300 R(Z) = R(Z) - 150
310 PRINT TAB( 7)F(Z); TAB( 22)INT (R(Z)) / 1000"K OHMS"
320 NEXT Z
330 PRINT
340 PRINT TAB( 10)"FOR C ="C * 1E6"UF"

```



152K *Lowest Price In The USA!* 152K

Computer System Sale

• Students • Word Processing • Home • Business



LOOK AT ALL YOU GET FOR ONLY **\$379**
LIMITED QUANTITIES
SYSTEM PRICE

- ① Atari 130XE 152K Computer
- ② Atari 1050 127K Disk Drive
- ③ Atari 1027 Letter Quality 20 CPS Printer
Atari Writer Plus Word Processor with Spell Checker
Atari BASIC Tutorial Manual

All connecting cables & T.V. interface included.
☆ Monitors sold separately.

LIST PRICE	INDIVIDUAL SALE PRICE
\$249.00	\$134 ⁹⁵
299.00	159 ⁹⁵
299.00	159 ⁹⁵
59.95	49 ⁹⁵
16.95	12 ⁹⁵
TOTALS	\$923.90
	\$517.75

SAVE OVER \$100
ALL 5 ONLY
\$379⁰⁰
SYSTEM SALE PRICE

CALL FOR 1027 PRINTER REPLACEMENT OPTIONS

Other Accessories

	List	Sale	
☆ 12" Hi Resolution Green Screen Monitor	\$199.00	\$79.95	Add \$9.95 for Connection Cables
☆ 13" Hi Resolution Color Monitor	\$399.00	\$159.95	Add \$10 for UPS

15 DAY FREE TRIAL. We give you 15 days to try out this ATARI COMPUTER SYSTEM!! If it doesn't meet your expectations, just send it back to us prepaid and we will refund your purchase price!! **90 DAY IMMEDIATE REPLACEMENT WARRANTY.** If any of the ATARI COMPUTER SYSTEM equipment or programs fail due to faulty workmanship or material within 90 days of purchase we will replace it IMMEDIATELY with no service charge!!

Best Prices • Over 1000 Programs and 500 Accessories Available • Best Service
• One Day Express Mail • Programming Knowledge • Technical Support

Add \$25.00 for shipping and handling!!

Enclose Cashiers Check, Money Order or Personal Check. Allow 14 days for delivery. 2 to 7 days for phone orders. 1 day express mail! We accept Visa and MasterCard. We ship C.O.D. to continental U.S. addresses only. Add \$10 more if C.O.D., add \$25 if Air Mail.

COMPUTER DIRECT

We Love Our Customers

22292 N. Pepper Rd., Barrington, Ill. 60010

312/382-5050 to order

A Versatile Printer Stand

This build-it-yourself printer stand provides three paper "trays" and features optional "smart" power and printer-selector switches

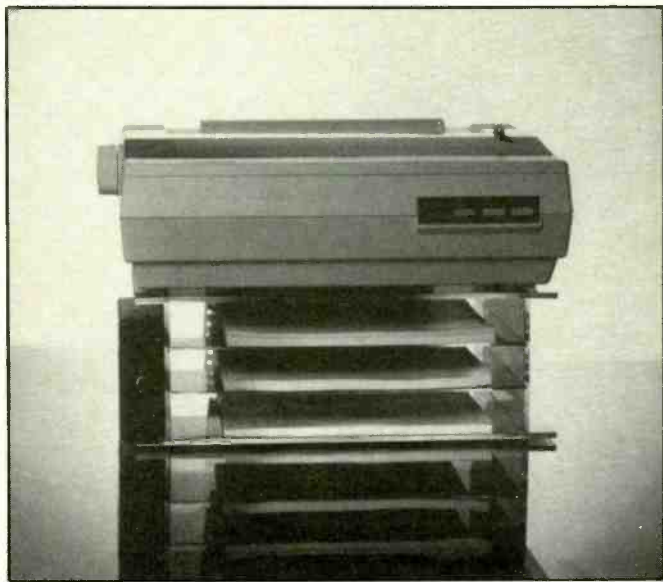
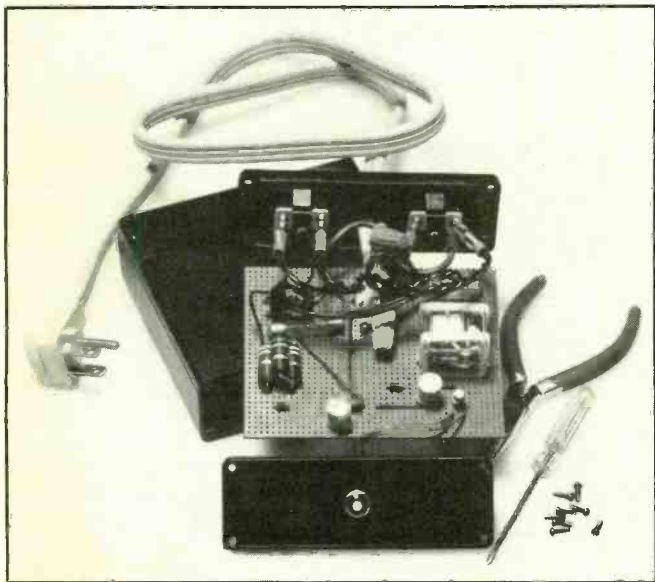

By Bill Green

There are a host of convenience features that one can add to personal computer systems to make use of these machines more efficient. A good example is modifying the typical printer/stand setup. At the grass-roots level, having to individually turn on and off power for each item in your computing system can be frustrating. So can juggling cables to switch from one printer to another. Finally, if you routinely use different papers and forms, changing from one to another can be an aggravating chore.

The projects to be discussed here can overcome these problems. The "Versatile Printer Stand" described solves the paper-changing hassle. Furthermore, it can be equipped with a "smart" switch that automatically turns on/off power with the flip of the power switch on just your com-

puter. Finally, you can add either a parallel or serial switch that will allow you to select either of two printers without having to unplug and plug in cables. Naturally, the last two devices can be used alone.

Smart Power Switch

Shown in Fig. 1 is the complete schematic diagram of the Smart Power Switch. This power controller can be used with any system containing two or more components that are usually switched on and off simultaneously. This might be a computer/printer/modem combination or a stereo receiver/tape recorder/VCR combination or whatever. (It can also be used as an add-on accessory to the "Computer System Power Controller" featured in *Modern Electronics*, Nov. 1985.)

The Smart Switch is designed to control ac line power to a slave ac

outlet when the equipment plugged into the master outlet is turned on and off. It does so automatically, relieving you of the need to individually turn on and off each device in your system. Pushbutton switch *S1* can be used to select between the Smart and Bypass functions. In the latter function, the Smart Switch is bypassed, requiring that you individually turn on and off any items plugged into the *SO1* and *SO2* ac receptacles.

Note in Fig. 1 that there are four diodes (*D1* through *D4*) connected in series with master receptacle *SO1*. When the computer or other device plugged into *SO1* is off, little or no voltage is dropped by these diodes and, hence, the rectified voltage at the base of *Q1* is not of sufficient magnitude to turn on the transistor.

When the device plugged into *SO1* is turned on, however, enough voltage is dropped by *D1* through *D4* to turn on *Q1*. This returns the low end

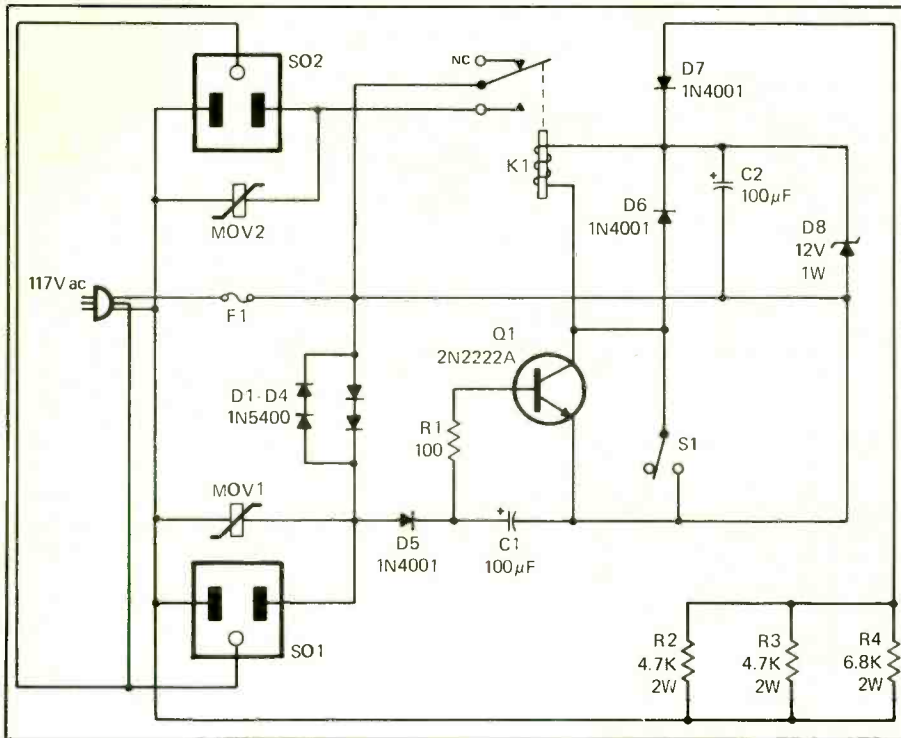

Fig. 1. This is the schematic diagram of the Smart Power Switch. Turning on/off the device plugged into SO1 automatically turns on/off any device plugged into SO2.

of relay *K1* to ground applying 12 volts to the relay's coil and closing its lower contacts.

With *K*'s contacts closed, ac line power is applied to slave receptacle *SO2*. Resistors *R2*, *R3* and *R4* form one side of the ac line and in series with rectifier diode *D7* and zener diode *D8* supply the 12 volts dc for *K1*. (Note: These three resistors can be replaced with a single 2000-ohm, 6-watt or more resistor.)

Fuse *F1* protects the circuit and should be selected to accommodate the total load expected to be drawn by the devices plugged into the master and slave receptacles. Of course, you must make sure that this load does not exceed the amount of power that can be safely handled by *K1*'s contacts. If you wish, you can substitute an appropriately rated circuit breaker for the fuse. Finally, *MOV1* and *MOV2* are included in the circuit to provide spike protection for any devices plugged into *SO1* and *SO2*.

You can assemble the Smart Switch on a printed-circuit board of your own design or a piece of perforated board and use solder posts to make the interconnections, using point-to-point wiring. If you install the project in a metal case, be sure to insulate it well to protect users from electrical shock. Also, be sure to use a 3-conductor grounded ac line cord and receptacles and to properly phase the cord and receptacles.

Two-Way Printer Switch

Here you have a choice of a parallel or a serial switch. The parallel ver-

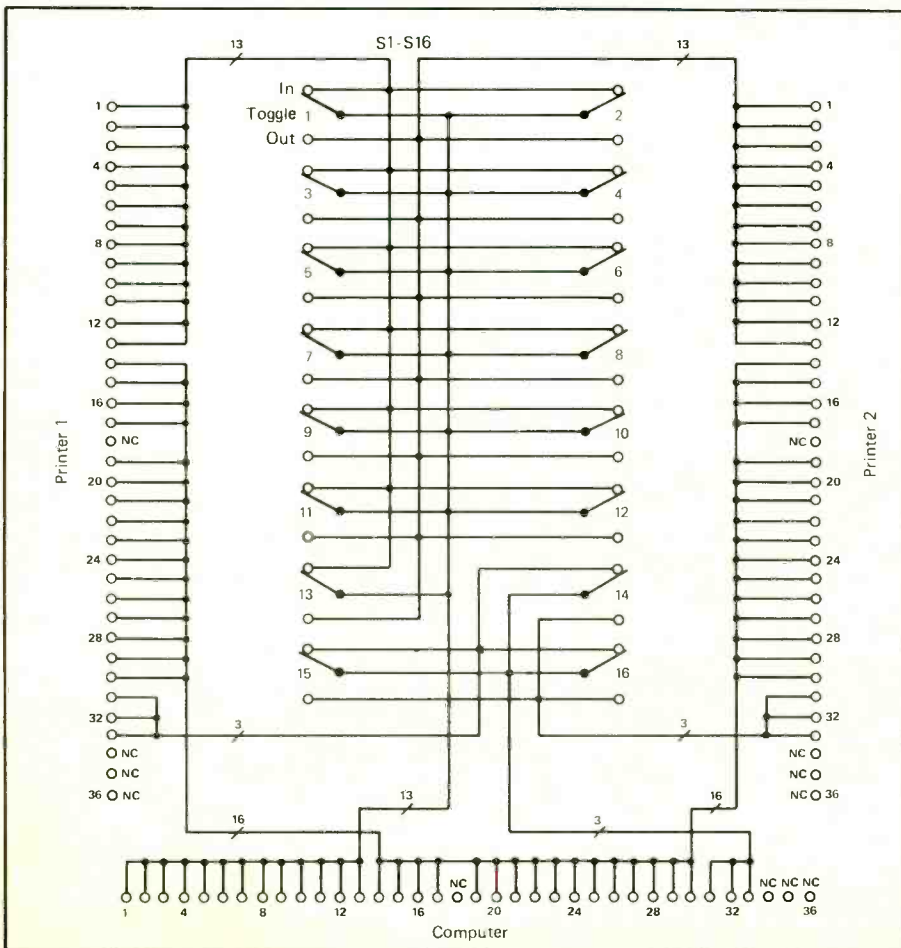

Fig. 2. Use this wiring diagram to assemble the printer switch for Centronics-compatible parallel printers.

sion is built around standard 36-pin Centronics-compatible connectors, the serial version around 25-pin miniature DB-25 connectors with flat ribbon cable and a 2-position pushbutton switch with 16 poles. The wiring diagram for the parallel version is shown in Fig. 2; that for the serial version is shown in Fig. 3. A case to house the two-way connector/switch circuit is optional.

Refer to Fig. 2 or 3, depending on whether you have parallel or serial printers, for all wiring details. You may have to modify the wiring to make it conform to your computer's and printers' wiring arrangements.

The Printer Stand

The printer stand shown in the lead photo is made from 1/4"-thick clear Plexiglas or Lucite, though if you are handy with tools and have a power router, it can be fabricated from 1/2"-thick plywood or particle board, using 1/4"-thick plywood or Masonite for the shelves. Dimensions for the various members that make up the stand are shown in Fig. 4 for both the Plexiglas/Lucite and wood versions, the latter in parentheses.

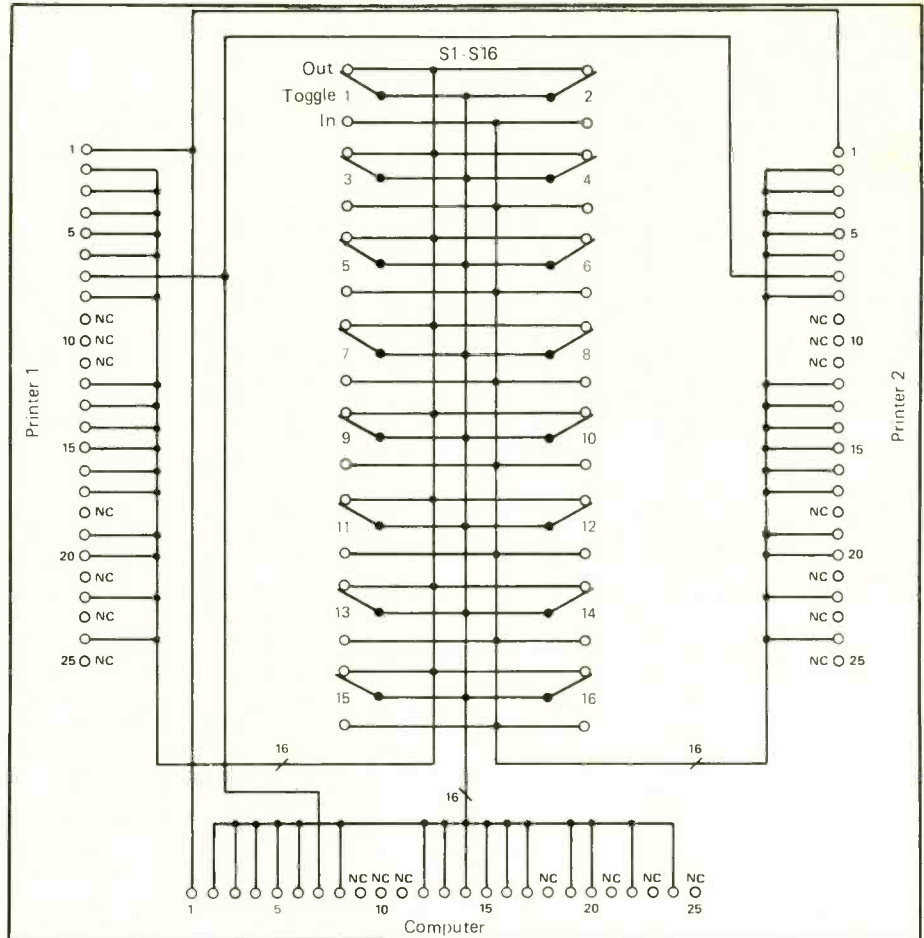

Fig. 3. Use this wiring diagram to assemble the 2-way printer switch for series printers.

PARTS LIST

Smart Power Switch

- C1,C2—100- μ F, 16-volt electrolytic capacitor
- D1 thru D4—1N5400 rectifier diode
- D5 thru D7—1N4001 rectifier diode
- D8—12-volt, 1-watt zener diode
- F1—Fuse (rating to suit load; can be replaced with circuit breaker—see text)
- K1—12-volt dc relay with 10-ampere contact rating (Radio Shack No. 275-218B or similar)
- MOV1,MOV2—130-volt MOV
- Q1—2N2222A npn transistor
- R1—100-ohm, 1/4-watt, 10% tolerance resistor
- R2 thru R4—2000-ohm, 6-watt, 10% tolerance parallel resistance (see text)
- S1—Spdt push-push switch (Radio Shack No. 275-1555 or similar)
- SO1,SO2—3-contact chassis-mount ac receptacle
- Misc.—Suitable enclosure (Radio

Shack No. 270-286 or similar) (see text); 3-conductor ac line cord with plug; printed-circuit board or perforated board and solder posts; machine hardware; hookup wire; solder; etc.

Printer Switch

- 3—Centronics 36-pin IDC connectors for parallel version (or 25-pin miniature DB-25 connectors for serial version)
- 1—2-position, 16-pole pushbutton switch
- 9 ft.—36-conductor (parallel version) or 25-conductor (serial version) ribbon cable
- Misc.—Suitable enclosure; machine hardware; hookup wire; solder; etc.

Printer Stand

- 2—15" \times 11" \times 1/4" acrylic sheets (or 15 1/2" \times 11" \times 1/2" sheets plywood or particle board)

- 2—11" \times 5" \times 1/4" acrylic sheets (or 11" \times 5 1/4" \times 1/2" sheets plywood or particle board)
- 2—12 3/4" \times 11" \times 1/8" acrylic sheets (or 12 3/4" \times 11" \times 1/4" sheets plywood or particle board)
- 4—Self-stick rubber feet
- 1—tube acrylic cement (or wood glue and finishing nails)
- Glass tinting film (or DAP and paint) (Items in parenthesis are for wood version of printer stand only; see text.)

Note: The following items are available from Alpha Electronics, P.O. Box 1005, Merritt Island, FL 32952: printer-stand kit (includes all acrylic, but not wood, materials cut, polished and slotted, plus acrylic cement and rubber feet) for \$49.95 until May 1, 1986 (\$69.95 thereafter) + \$6.00 P&H in U.S.; 2-position, 16-pole switch for 2-way computer switch for \$18.00 + \$2.00 P&H in U.S. Florida residents, please add sales tax.

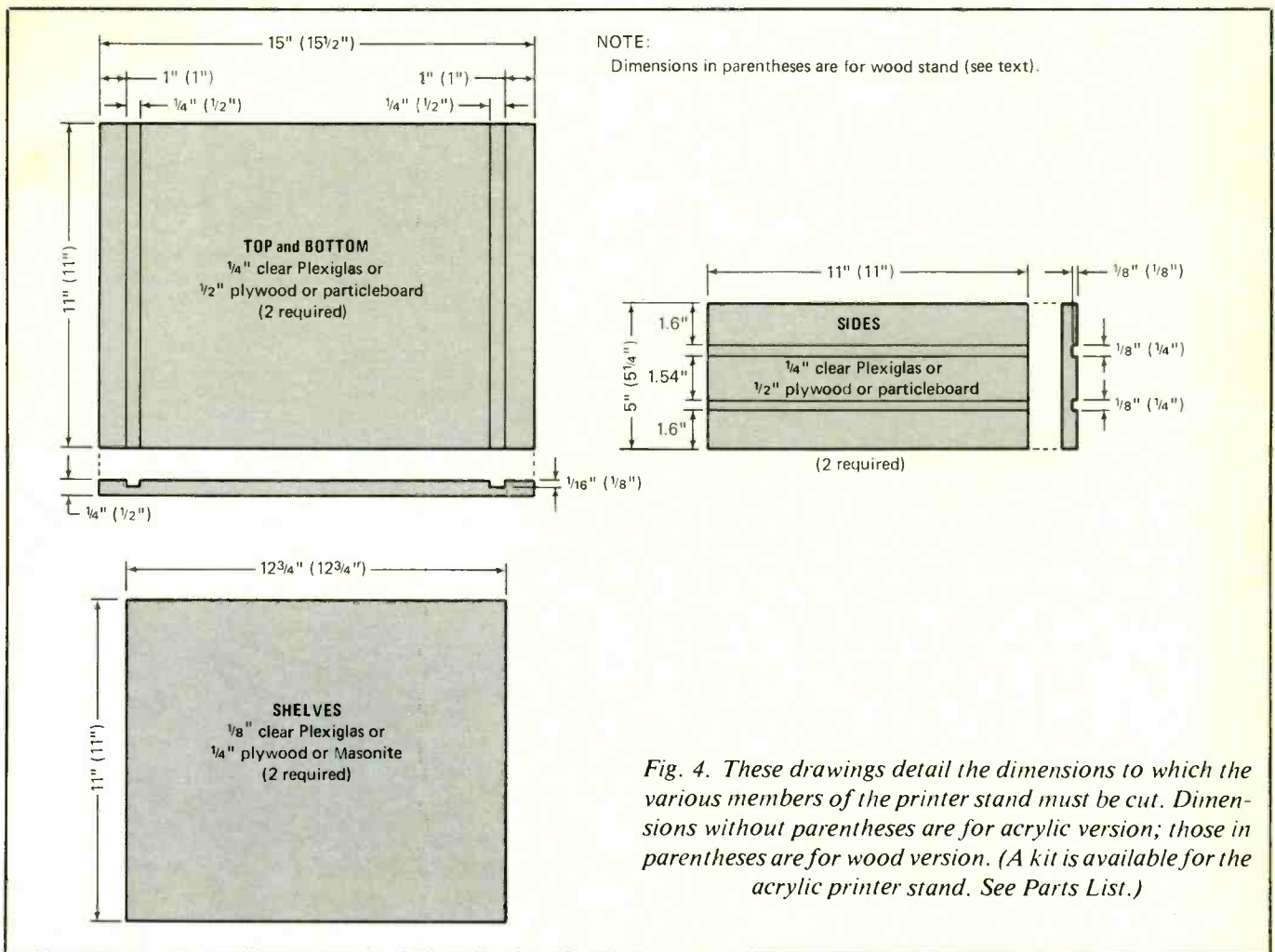

Fig. 4. These drawings detail the dimensions to which the various members of the printer stand must be cut. Dimensions without parentheses are for acrylic version; those in parentheses are for wood version. (A kit is available for the acrylic printer stand. See Parts List.)

Plexiglas and/or Lucite are available from a number of sources. These include plastics suppliers, glass companies, many hardware stores and home-improvement centers. Most places that sell this material will cut it to order for a fee. You can, however, easily cut it yourself, with a scribing tool or a table saw equipped with a carbide blade. (*Caution:* If you decide to cut or machine sheet Plexiglas or Lucite yourself, always wear safety glasses.)

Refer to Fig. 4 for cutting instructions. If you are using the plastic material and cut it to size with a saw, you must polish the edges. The slots you must cut in the top, bottom and side panels are cut with a 1/8"-wide carbide-tipped blade, using a single pass

for the 1/8" slots and two passes for the 1/4" slots.

After all panels are cut to size, run a thin bead of acrylic cement (available from the same source from which you obtained the sheet plastic and some hobby shops) down both slots on the bottom of the stand. Set the side panels, with the slots facing inward, into the slots, and use a triangle to square the sides with the bottom panel. Allow the acrylic cement cure for at least 10 minutes.

Place the top panel on a flat surface, slotted side up, and run a thin bead of cement down both slots. Invert the bottom/side assembly and lower it onto the top panel, aligning the side edges with the slots in the top panel. Push the assembly home and

allow the cement to cure for at least 10 minutes. Then mount four adhesive-backed rubber feet on the bottom panel, spacing them about 1" in from each corner.

Finally, insert the two shelves into the stand. At this point, if you wish, you can apply glass tinting film to the stand or spray it with a paint that suits your taste.

Assembling the wood version of the stand is accomplished in much the same manner as for the plastic version. Before assembling the panels, sand them for a smooth finish. Then perform the steps in the same sequence as above, except use wood glue and finishing nails in place of the

(Continued on page 96)

A Day/Night Safety Beacon

Based on electronic photoflash circuitry, this portable safety device can be seen by oncoming traffic both day and night

By Anthony J. Caristi

One can't be too careful when it comes to safety, especially when exposed to highway or road dangers while traveling. The portable Safety Beacon to be described here will come in handy as a safety device for a disabled automobile, a bicycle or other vehicle. Unlike ordinary warning lights, its piercing flashing light, based on electronic flash circuitry, can be easily seen day or night from a long distance. It commands attention, while not "blinding" oncoming traffic. On a bicycle or motorcycle, it can be left on continuously to alert automobile drivers.

Its built-in battery makes it completely independent of any other power source for full portability. Powered from three fresh C-size cells, it will provide about 100 hours of operating time. Current drain is far less than that required by a common three-cell flashlight. To further enhance the Safety Beacon, you have the option of using rechargeable nickel-cadmium cells to even eliminate the bother of having to periodically replace the spent cells. And if you wish to operate the project from a 12-volt automotive electrical system, a simple modification is all that's required.

How It Works

A xenon flashtube like those commonly used in many types of cameras is the heart of the Safety Beacon. Power for flashing the tube is provided by a simple dc-to-dc converter

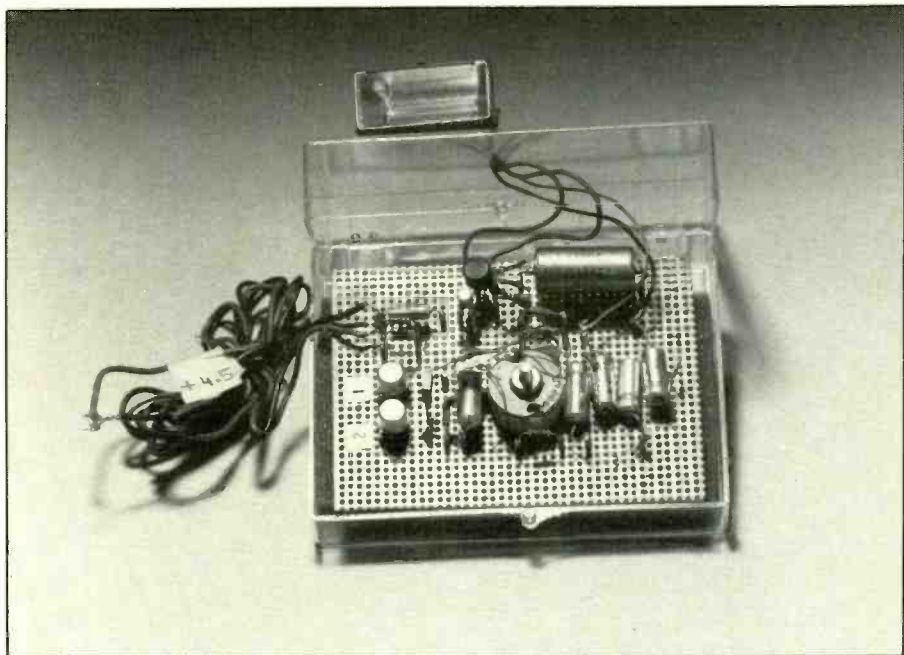

that steps up the low battery potential to about 250 volts dc.

Xenon flashtubes produce light when a capacitor charged to a relatively high voltage is suddenly discharged through them. The energy expended in the flashtube is proportional to the voltage and capacitance. In this project, this energy is low (about 0.333 watt-second) to assure long flashtube life and to produce a bright but not blinding flash.

In the dc-to-dc converter shown in Fig. 1, you must wind the transformer identified as *T1*. Note that *T1* has three separate windings. In this circuit, *Q1* and *Q2* are forced into oscillation by positive feedback to their bases from the upper winding labeled 1/2/3.

Due to the relatively high turns ratio between the primary (4/5/6) and secondary (7/8) windings of *T1*, the switching action of *Q1* and *Q2* induces a high voltage into the secondary circuit. This voltage is passed through the *D1/D2/C3/C4* voltage-doubler circuit. Here, each capacitor is charged to about 125 volts, and the sum of the charges (250 volts) is fed to flashtube *FT1*.

Although a high voltage is present across *FT1*, the flashtube won't conduct (flash) until it's triggered by a very high potential of (4000 volts or more) applied to the "trigger" electrode. (The trigger voltage is not dangerous because it has no current behind it.)

Autotransformer *T2*'s primary is

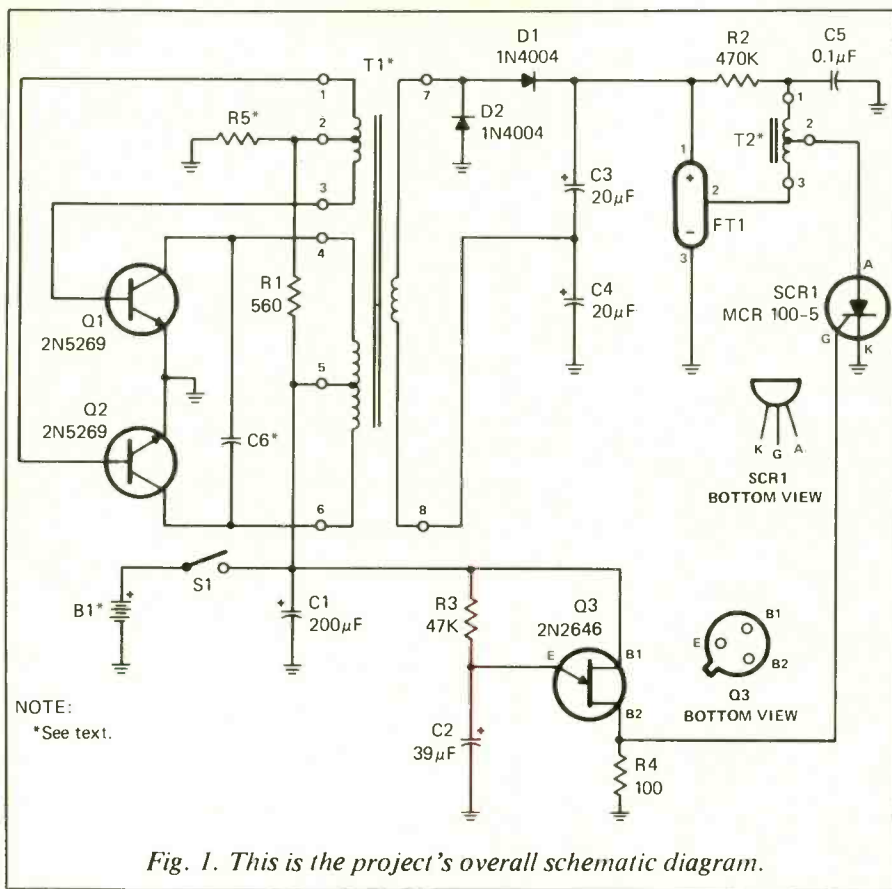

Fig. 1. This is the project's overall schematic diagram.

the winding between terminals 1 and 2. To generate repetitive flashes, unijunction transistor *Q3* is connected as a very-low-frequency relaxation oscillator, via *C2*, *R3* and *R4*.

When power is applied to the circuit and *C2* charges to about half the battery voltage, *Q3* suddenly conducts from emitter (E) to base 1 (B1). This dumps the charge stored in *C2* into *R4*. Capacitor *C2* then begins to recharge, and the process is repeated once every 4 or 5 seconds, as determined by the *R3/C2* time constant.

A capacitive-discharge circuit is made up of *T2*, *C5* and *Q4*. Charging of *C5* to 250 volts is accomplished through *R2*. Though *T2* is also connected to *C5*, current can't flow in the transformer primary because silicon-controlled rectifier *SCR1* isn't yet triggered into conduction.

When *Q3* switches on, the regulating voltage spike that appears across *R4* is also applied to the gate

(G) terminal of *SCR1*. This causes the SCR to switch on and suddenly apply the 250 volts stored in *C5* to *T2*'s primary. The *C5/T2* primary (LC) circuit dissipates the charge as a burst of oscillation.

Since *T2* has a step-up ratio, when the charge on *C5* is being dissipated, the energy at the secondary is at least 4000 volts. This potential, applied to the trigger electrode of *FT1*, causes the flashtube to conduct, allowing most of the energy stored in *C3* and *C4* to be converted into heat and light. It's this conversion that produces the flash. The cycle repeats for as long as power switch *S1* is closed and there's sufficient voltage in *B1* to excite the circuit. The repetition rate is 4 or 5 seconds.

Construction

Begin construction by fabricating transformer *T1* (see box for details). Once the transformer is ready, wire

PARTS LIST

Semiconductors

- D1, D2—1N4004 rectifier diode
- Q1, Q2—2N5236 or similar transistor
- Q3—2N2646 or similar unijunction transistor
- SCR1—MCR 100-5 (Motorola) or similar silicon-controlled rectifier

Capacitors

- C1—20C- μ F, 15-volt electrolytic
- C2—39- μ F, 10-volt electrolytic
- C3, C4—20- μ F, 150-volt electrolytic
- C5—0.1- μ F, 300-volt Mylar or ceramic
- C6—0.22- or 0.0047- μ F, 100-volt disc (see text)

Resistors (1/4-watt, 10% tolerance)

- R1—56C ohms
- R2—47C,000 ohms
- R3—47,000 ohms
- R4—10C ohms
- R5—68 ohms (12-volt units only—see text)

Miscellaneous

- FT1—250-volt flashtube (Radio Shack No. 272-1145 or similar—see text)
- S1—Sps. slide or toggle switch
- T1—Hand-wound transformer on TDK P22.5 Z52H pot core (see text)
- T2—Trigger transformer (Triad No. PL-10 or similar) Printed-circuit board or perforated board and solder posts; transistor sockets; heavy-duty stranded hookup wire for power leads; suitable enclosure; hookup wire; No. 30 and No. 36 enameled wire; machine hardware; solder; etc.

Note: The flashtube and trigger transformer are available as Cat. No. 32SC430 from Hi Tek Sales, 119R Foster St., Peabody, MA 01961. The following are available from A. Caristi, 69 White Pond Rd., Waldwick, NJ 07463: pc board for \$6.75; pot core/bobbin for T1 for \$6.75; 2N2646 transistor and MCR 100-5 SCR for \$2.75 each. Add \$1.00 S&H.

the circuit on either a printed-circuit board or on perforated board using solder posts. The pc board (see Fig. 2 for the actual-size etching-and-drilling guide) is recommended if you want a very compact project. Other than this, since there's nothing critical with regard to layout, either method can be used with success.

If you use a pc board, refer to the diagram in Fig. 2 for component

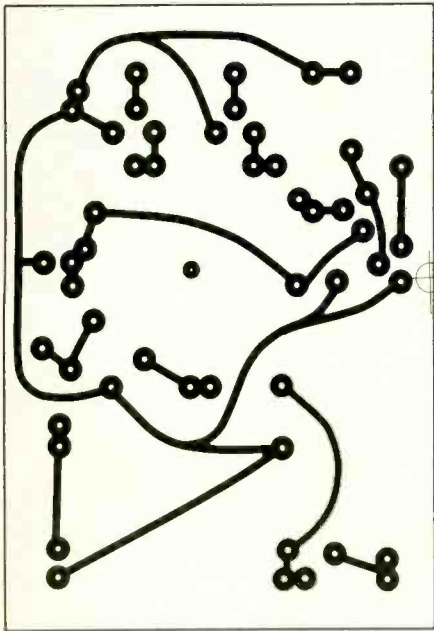

Fig. 2. Etching-and-drilling guide.

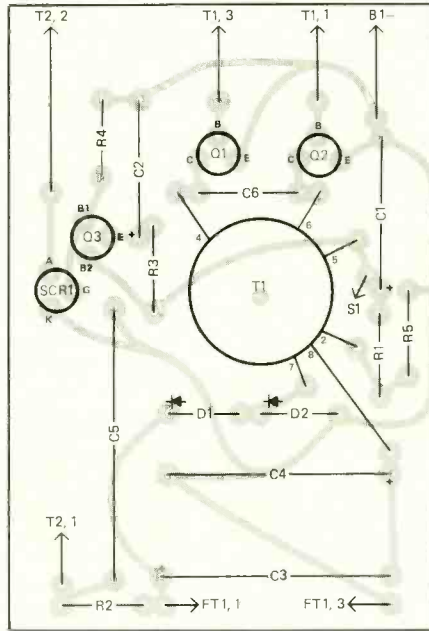

Fig. 3. Components-placement guide.

placement and orientation. If you go the perf-board route, you can use the same layout shown in Fig. 3, but you'll have to refer back to Fig. 1 for wiring details and leave extra room for wiring. Regardless of the wiring method you use, pay careful attention to the polarization of the diodes, electrolytic capacitors and battery, and to lead designations for the transformers, flashtube, transistors and SCR. Also, it's a good idea to use sockets for the transistors and SCR should this ever become necessary and to facilitate the steps in the checkout procedure.

When mounting *T1* on the circuit board, be very careful to avoid over-tightening the hardware, or the very

Winding The Transformer

The only component the Safety Beacon calls for that isn't readily available from the usual parts sources is transformer *T1* in Fig. 1. Though you must wind this transformer yourself, the task isn't particularly difficult. The materials you need are readily available and consist of a pot-core/bobbin assembly (see Parts List for type and availability), some No. 30 and No. 36 enameled wire and thin tape.

Wind the 1/2/3 feedback turns (see Fig. 1) first. This winding consists of 10 turns of enameled wire with a tap at the fifth turn. Wrap exactly 10 turns of wire onto the pot core's bobbin and add 7" to this amount. Clip the wire and unwind it from the bobbin. Fold the wire exactly in half.

Carefully scrape away, down to bare wire, 1/4" of the enamel coating from both ends and centered at the fold. Scrape away 1/4" of enamel from both ends of another 3" length of wire and twist one end of it together with the bared wire at the fold. Solder the center-tap connection and wrap it with insulating tape.

Now, starting 3 1/2" from one end, wrap exactly 10 turns of this wire

around the bobbin. Use pieces of tape with the numerals 1, 2 and 3 on them to identify the beginning, center tap and end wires, respectively. When you're finished winding this coil, you should have two leads that measure 3 1/2" and one that measures 3" in length. Remember the direction in which you wound this coil (draw an arrow pointing in this direction on the bobbin). Wrap a couple of turns of thin, preferably Mylar, tape over the feedback coil.

Next comes the primary winding, which must be "bifilar" wound. That is, two lengths of wire used to make this coil must be wound at the same time to achieve the tightest possible coupling between the two coil halves. (Tight couplings minimizes voltage spikes that appear across *Q1* and *Q2*.)

The 4/5/6 primary winding in Fig. 1 consists of 13 double turns of wire if the project is to be powered from a 4.2-to-4.5-volt source or 27 double turns if it's to be powered from a 12-volt source. Cut a 48" length of wire for the 13-turn or 96" wire for the 27-turn primary. Fold the wire exactly in half and remove 1/4" of enamel from the ends and center fold exactly as described

above for the feedback winding.

Starting at the center-tap lead and holding the wires together, wind the correct number of turns on the bobbin in the *same* direction as you wound the feedback coil. Label the ends of this winding with numbers 4 and 6 tags and the center tap with a number 5 tag. Then wrap a couple of turns of thin tape over the winding.

The 7/8 secondary winding in Fig. 1 is made up of 240 turns of No. 36 enameled wire wound in either direction. Be sure to accurately count the turns as you wind the wire onto the bobbin, since the number of turns will determine the dc potential that will be applied to the flashtube. When winding is done, secure the coil with a couple of layers of thin tape. Then scrape away 1/4" of enamel from both wire ends and label these wires with the numbers 7 and 8.

Place the bobbin assembly inside the pot core, arranging the winding leads so that they don't obstruct assembly. Then secure the two halves of the pot core with a couple of layers of tape. You can now install the transformer on your Safety Beacon's circuit board, referring to Fig. 1 for wiring details.

brittle core may crack or shatter. Also, place a fiber washer between the head of the screw and the core.

The flashtube and trigger transformer can be obtained from the source given in the Parts List, or you can salvage them from the electronic photoflash of an old camera. If your trigger transformer has isolated windings (separate primary and secondary leads), simply connect one primary wire to the low potential side of the secondary and attach these to the "hot" or + side of C5.

The value of C6 will be different for a 12-volt than it is for a 4.5-volt unit. Use a 0.0047-microfarad capacitor for a 12-volt power source, a 0.22-microfarad capacitor for a 4.5-volt source. This capacitor *must* have a rating of at least 100 working volts. Also, for the 4.5-volt supply unit, omit R5; use 68 ohms for a 12-volt supply unit.

Power for the Safety Beacon can be from three common C or D cells connected in series to provide 4.5 volts. Alkaline cells, of course, will provide longer operating life than will carbon-zinc cells. If you prefer, you can use three rechargeable Ni-Cd cells to provide 4.2 volts. (*Caution: Do not use more than 4.5 volts to power the low-voltage unit.* To do so will dramatically shorten flashtube life and will result in excessive voltage being applied to the circuit's components). Current drain from the battery is about 100 milliamperes, which provides an operating life of 100 hours from one set of C cells.

Checkout

Before placing your Safety Beacon into service, you must check it out for proper operation. All you need for this procedure is a dc voltmeter with at least a 1-megohm input and the ability to measure 10 to 300 volts.

Remove Q1 and Q2 from the circuit. Connect the voltmeter across C2, with the positive probe touching the positive lead of the capacitor. Set

the voltmeter's range selector to a position that will allow you to read 10 volts. Apply power to the circuit; the voltmeter's indication should slowly rise to a little more than half the input voltage and then suddenly drop to almost zero. This rise and fall should repeat every 4 or 5 seconds as Q3 oscillates. If you don't obtain the proper indications, check the Q3/R3/C2/R4 circuit and especially for proper lead connections for Q3 in its socket. Do *not* proceed with checkout until you obtain an indication that Q3 is oscillating.

Turn off the power. Then plug Q1 and Q2 in their sockets. *Caution: High voltage is present in this circuit. Therefore, for the remainder of this procedure, make sure you don't touch any of the circuitry or the flashtube.*

Connect the positive probe of the meter to the positive side of C3 and the negative probe to the negative side of C4. Set the meter to allow you to read 300 volts or more. Apply power to the circuit; the reading should slowly rise toward 250 volts and, after 4 or 5 seconds, the flashtube should flash, causing a drop in the meter reading to about 50 volts. This sequence should repeat at 4- or 5-second intervals.

If you obtain the proper high voltage but the flashtube doesn't flash, check Q3 to make sure that it's oscillating at a rate of one cycle every 4 or 5 seconds. Also, check Q4's orientation and the wiring to trigger transformer T2. If everything looks okay, you may have a defective flashtube or one not rated to flash with a 250-volt dc potential. If possible, try another flashtube.

If you don't obtain a high-voltage reading across C3 and C4, the most likely cause is the Q1/Q2 oscillator circuit. The phasing of T1's 1/2/3 feedback winding may be reversed because you inadvertently wound the turns in a different direction from that of the primary. If reversing wires 1 and 3 doesn't help, reconnect the wires to their original points. Review the winding instructions given in the

box to determine if you made an error in winding.

If you're satisfied that the transformer is properly wound, check the orientations of Q1, Q2, D1 and D2. If possible, try two new transistors for Q1 and Q2.

Mount the circuit-board assembly in a suitable enclosure. Then decide where and how to mount the flashtube to assure that it will be seen by other traffic on the road. This will require different mounting techniques for different vehicles and situations. If you're using the Safety Beacon in a vehicle whose electrical system is to power it, you'll have to run power heavy-duty stranded leads to it from a convenient tap-off point in the vehicle's electrical system. In any event, make sure that you house the flashtube so that its glass envelope is protected and that its power leads are well shielded to prevent electrical shock. **ME**



Wondering when the new Dick Smith Electronics Catalog was coming out?

Our new '86 catalog is scheduled for April release. It's Bigger & Brighter, with hundreds of exciting new products & pages of useful data. Hurry to reserve your copy now!

DICK SMITH ELECTRONICS
Where you'll find
**EVERYTHING FOR THE
ELECTRONICS ENTHUSIAST!**

Please reserve my copy of the 1986 Dick Smith Catalog. I enclose \$1 to cover shipping.

Name

Address

City

Zip

DICK SMITH ELECTRONICS INC.
P.O. Box 2249 Redwood City CA 94063
EVERYTHING FOR THE ELECTRONICS ENTHUSIAST



Add Stereo Sound To Your TV Receiver



This device readies any TV receiver to use a commercial stereo TV converter for full-spectrum stereo sound reproduction

By Gary McClellan

Stereo TV sound is here! Once you hear it, you'll agree that stereo sound does for the 1980s what color pictures did for the 1960s. The bad news, however, is that ordinary TV receivers can't decode the stereo signal, and those that can are currently quite expensive. The good news is that there are already on the market a number of converters that can provide stereo sound—but only if your set is "stereo-ready."

However, you can ready any TV set to decode stereo through a suitable converter using the simple circuit described here. A stereo-ready capability obviates the need to buy a new set to take advantage of stereo sound. By itself, this project won't give you stereo sound directly (you need a stereo TV converter for that). But it does provide high-quality mono sound directly and prepares your set to use a stereo converter that will let you enjoy full-spectrum stereo sound.

Installation doesn't affect normal

operation—it enhances it. A built-in squelch circuit mutes annoying interstation noise, and a level control matches the project to the various stereo converters now available to obtain optimum performance.

Installation entails only two solder connections to your TV set. A few adjustments you do by ear then get the system in proper operating order.

Project cost is just \$25, which gets you both superb mono sound and stereo-ready capability. Add another \$100 to \$200 for a stereo TV converter, and you get full-spectrum stereo sound as well.

About the Circuit

This project performs several different tasks in order to make your TV receiver "stereo ready." Its first task is to electrically isolate the TV chassis from your sound system. This is mandatory for both safety and technical reasons. To keep costs down, modern TV receivers no longer have power transformers and, thus, have their chassis "grounded" to one side of the ac line. This being the case, up to 117 volts ac can appear on the

chassis, making it a potentially lethal shock hazard if you touch any exposed metal parts that are electrically connected to the "hot" chassis. Therefore, this project ensures full electrical isolation from the TV receiver. It also blocks the TV receiver's 15,734-Hz horizontal sweep signal from entering the stereo TV converter to prevent false triggering that would spoil both mono and stereo sound reception.

The project amplifies and detects the 4.5-MHz sound i-f signal as it comes from the TV set's i-f strip. This amplification is essential because the existing sound detector circuit, lacking the wide bandwidth of the project, would prevent stereo reception. The project also outperforms the sound detector in your TV set by providing more gain at 4.5 MHz and less distortion and provides a squelch circuit to boot.

As shown in Fig. 1, the project taps into the TV set's i-f amplifier section just before the regular sound-detector circuitry. This has little or no effect on the existing circuitry or the set's normal sound. At this point, the

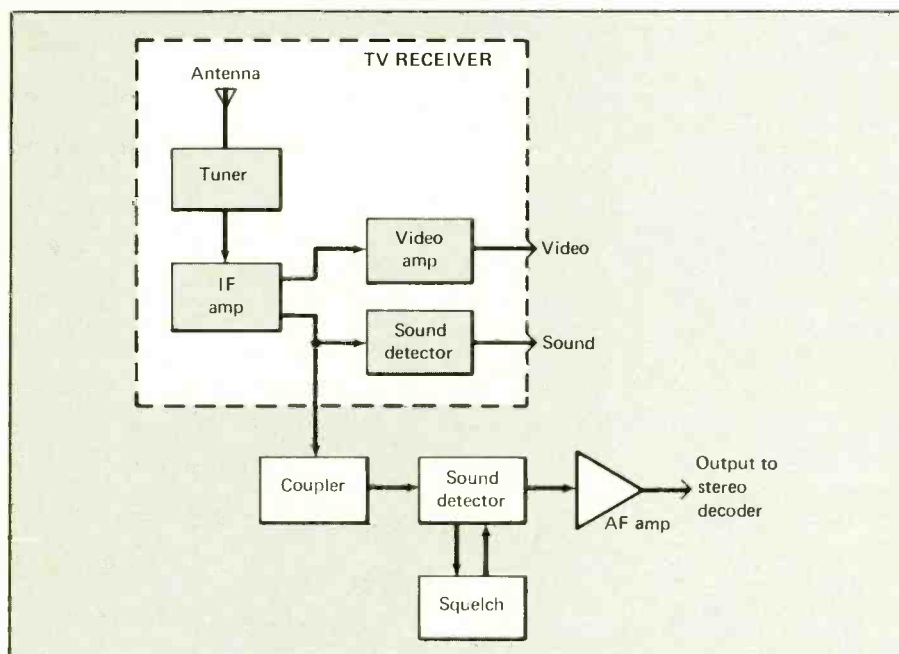

Fig. 1. This block diagram shows the main sections of the typical TV receiver (boxed section), this project's circuit, and the connections to a TV receiver.

low-level 4.5-MHz sound i-f signal goes to a tuned-transformer coupler that drives a simple sound detector.

A "do-everything" CA3089 IC amplifies the signal, detects it and provides an audio output. This low-cost IC provides high signal gain and requires a minimum number of support components.

The squelch circuit controls the CA3089 sound detector IC with a simple two-transistor amplifier circuit that improves the performance of the squelch built into the IC. (The CA3089 was not originally intended to work at 4.5 MHz, after all.)

Finally, a one-transistor audio amplifier boosts the output from the sound detector to a range suitable for the most insensitive TV converter. Up to several volts of audio signal is available for driving a high-impedance load.

Shown in Fig. 2 is the actual schematic diagram of the project. It details the finer points of the Fig. 1 block diagram. Starting with the coupler circuit, the 4.5-MHz sound i-f from the TV set enters at the "IF" terminals. Capacitor *C1* blocks dc

from the TV set from appearing across *L1* and upsetting the TV sound detector. Coil *L1* couples the signal into nearby coil *L2*. The latter is peaked by *C2* for maximum output at 4.5 MHz.

Next, in the sound-detector circuit, *C3* and *C4* impedance match and couple the high-impedance tuned circuit into the low-impedance output of *IC1*. This IC internally amplifies the 4.5-MHz signal and outputs it at pin 9. Here, *L3* and *C9* tune the detector to 4.5 MHz and convert the signal into audio. Resistor *R7* "broadbands" the *L3/C9* circuit to reduce distortion and simplify adjustment. (Incidentally, the CA3089 has a quadrature detector that provides less than 0.5% distortion in this circuit.)

Part of the detector signal is tapped off by *R8* and detected by a level detector circuit on pin 8. This is the beginning of the squelch circuit. The detector output is a dc voltage that appears on pin 12 of *IC1*. The squelch circuit consists of *Q1* and *Q2*, which form a noninverting dc amplifier that boosts the signal from

SQUELCH control *R2*. The amplifier output is a digital-level signal that controls pin 5 of *IC1*. When this pin goes high (about 5 to 6 volts), audio passes through *IC1*. Bringing pin 5 low (near ground) blocks audio via a switch inside *IC1*. Note that the signal at pin 10 of *IC1* (a 6-volt output from an internal voltage regulator) powers the squelch circuit.

At pin 6 of *IC1* appears the audio output signal. Amplifier *Q3* boosts this signal to several times its original level. At this point, GAIN control *R11* is used to vary the effect of *C12* in the circuit—which is an easy way to get the limited range of gain control required. Note that the audio appears at the "AF" terminals.

Finally, the project is powered by an external 12-volt dc plug-in type transformer that connects to the terminals labeled "DC." A possible alternative to this powering scheme is to tap power from the stereo converter with which the project is used, since only about 20 mA is required.

Construction

A printed-circuit board is mandatory for this project because of the high-gain circuitry involved. This board can be obtained ready to use from the source given in the Parts List, or you can make your own using the actual-size etching-and-drilling guide in Fig. 3. Wire the board exactly as shown in Fig. 4. Be sure to properly orient the components, and keep all leads as short as possible to prevent oscillation. Make sure trimmer capacitor *C2*'s flat side is installed as shown; otherwise, you may have trouble when adjusting this capacitor later.

Start wiring the board by installing the resistors, followed by the capacitors. Then install *L1* and *L2* and push them together. Continue on to the IC socket. When all components have been installed, carefully check the board for missed solder joints, poorly soldered connections and solder bridges. Then carefully check the pc

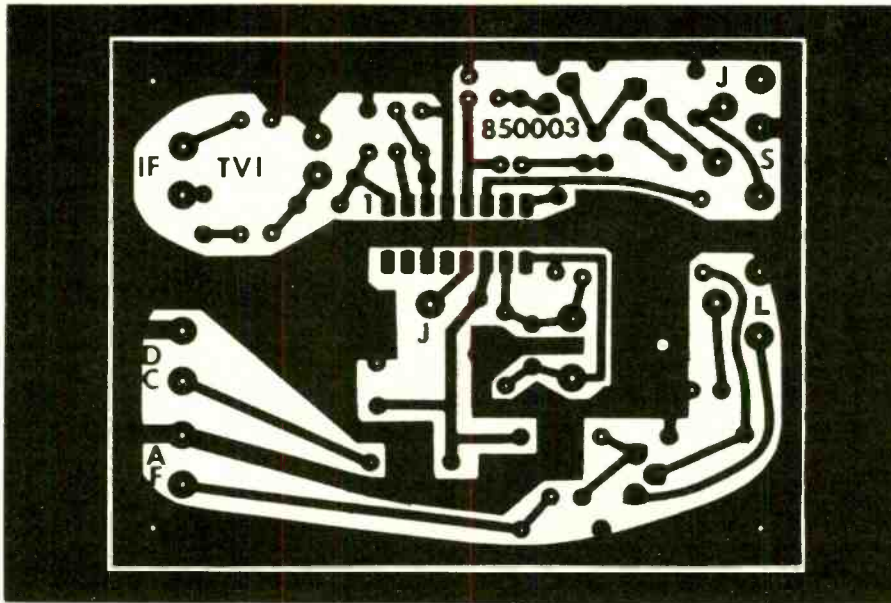

Fig. 3. If you wish to fabricate your own printed-circuit board, use this actual-size etching-and-drilling guide.

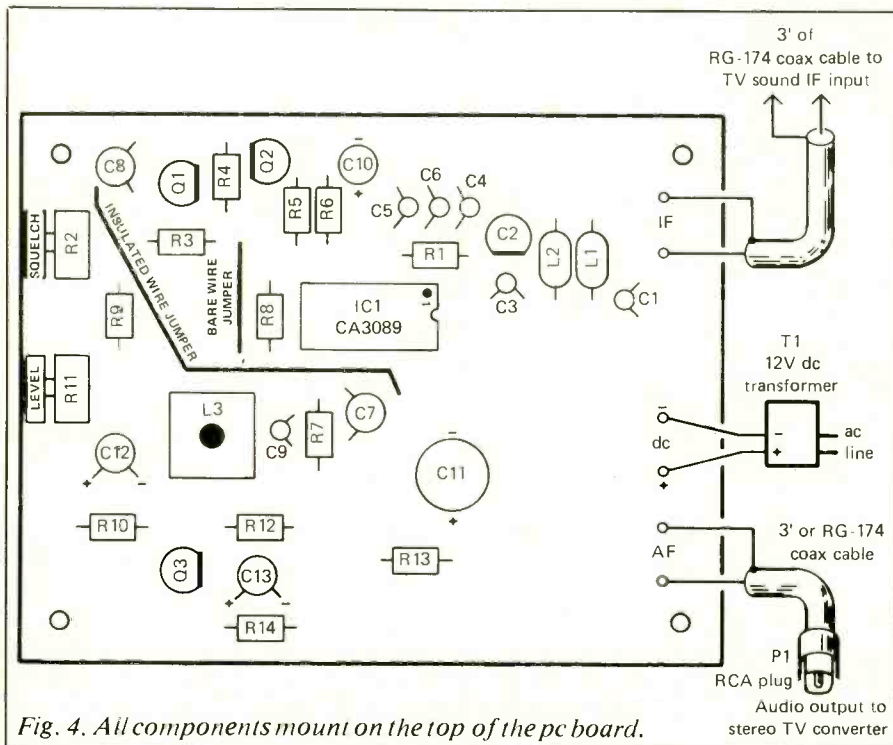

Fig. 4. All components mount on the top of the pc board.

pare the board-end of the cables. Then pass their prepared ends through the grommet-lined holes and solder the conductors to the appropriate pads on the board (see Fig. 2 for details). Before soldering the power leads to the + and - DC pads

on the board, plug the 12-volt transformer into an ac outlet and use a meter to determine the polarity of the leads. Disconnect the transformer from the ac line and solder the conductors to the appropriate pads.

Mount the circuit board on the

floor of the case, using four $\frac{1}{4}$ " spacers and $4-40 \times \frac{1}{2}$ " machine screws, nuts and lockwashers. Place a cable clamp around the INPUT, OUTPUT and POWER cables and fasten them to the wall of the case with $6-32 \times \frac{3}{8}$ " machine hardware, leaving slight loops in each to relieve tension. The cable clamp serves as a strain relief that prevents the cables from being torn loose from the board.

Prepare the free end of the OUTPUT cable by removing 1" of outer insulation, separating the shield back to the insulation, clipping $\frac{3}{8}$ " from the inner conductor, and removing $\frac{1}{4}$ " of insulation from the inner conductor. Connect and solder to this end of the cable a standard phone plug. Prepare the free end of the RG-174 coaxial cable in like manner, but do not clip the inner conductor to $\frac{3}{8}$ " in length. Tightly twist together all the fine wires in the braided shield and sparingly tin with solder. Do the same with the fine wires in the inner conductor. (Note: if you have coaxial cable with a foil shield, trim the shield—not the wire that parallels the inner conductor—back to the cutoff point on the outer conductor. With this type of cable, you must solder-tin the inner-conductor wires only.)

At this point, a few preliminary checks should be performed with the aid of a multimeter, preferably a DMM if you have one. Set the meter to its ohms function and highest range. Connect one test probe to the INPUT cable, shorting it across both cable conductors. Touch the other lead to first one and then the other contact on the OUTPUT phono plug, to an unpainted area inside the project's case and finally to one and then the other prong on the transformer. Then touch the test probes to the INPUT cable's conductors. If while performing these tests you obtain a reading of other than infinity, immediately check your wiring and correct the problem before proceeding.

As a final test, set your meter to its dc voltage function and set the range

Why No Converter Project

Some readers may be wondering why we are not providing construction details for a complete stereo TV converter. There are good reasons for not doing so. The primary reason is that the components needed to make such a converter are very difficult to obtain, because stereo TV uses an integral noise-reduction system. This effectively prevents utilization of low-cost FM stereo decoder chips. A special stereo TV decoder chip, like National Semiconductor's LM-1884 or Panasonic's AN-6291 noise-reduction chip must be used. Unfortunately, both are so new that they are not available through regular electronics parts distributors.

A second reason for not including plans to build your own stereo converter stems from the fact that stereo TV converters are complex and require many adjustments to be made to get them working properly. A special stereo TV alignment generator is required for alignment, without which you would not be able to align "by ear" as you can with an FM radio stereo decoder. Making matters worse is the fact that this instrument is not yet on the general market—even if you did not mind paying the price for it just to build your own stereo TV converter.

to read 20 volts. Plug *T1* into an ac outlet and touch the meter's positive probe to pin 11 and negative probe to project ground. If you don't obtain a reading between 11.5 and 13 volts, once again check for wiring errors and, if you don't find any, one or more bad components.

Making the Connection

You're now ready to connect the project to your TV receiver. This entails connecting the INPUT cable to the sound i-f section inside your set, after which you mount the project on the set's rear panel with 6-32 × 3/8" machine hardware.

Keep firmly in mind that there are dangerous high voltages present inside your TV set, even with the power

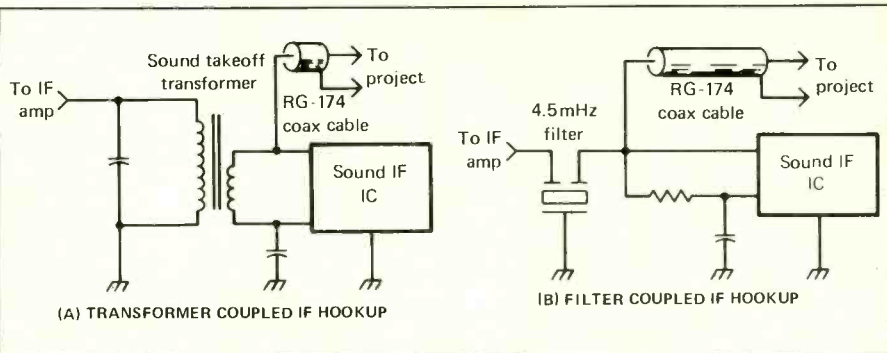

Fig. 5. Shown here is where to tap into the two circuits typically used in TV receivers. Check your set to determine which circuit it has, and then use the appropriate schematic to make the connections to the project.

turned off. In and around some of the circuits, some of these voltages are potentially lethal. So before doing anything else, disconnect the set's power cord from the ac line. If at all possible, wait several hours before removing the back panel from the set. When you do remove the back panel, keep as far away as possible from the picture tube area and the high-voltage power supply. Even after hours without power, these areas may still have enough voltage in them to give you a nasty jolt.

Figure 5 shows how the connections are actually made to your TV set's sound detector circuit. Note that some sets use a transformer (circuit A), while others use a 4.5-MHz ceramic filter (circuit B). If you can do so, obtain the schematic diagram for your TV receiver. If you can't, you may have to seek out the help of a professional TV technician.

It's up to you to determine exactly where in your particular set to make the INPUT cable connections. Regrettably, there are so many different models of TV receivers on the market that we can't give you more than very minimal assistance in this article. You might check the inside of your set's back panel for a module or transistor/IC placement label. This will often get you to the right place fast. You can then remove the module or access the foil side of the board.

Your first step is to locate the

transformer or filter. Then pass the free end of the cable through a hole in the back panel (you might have to drill it) and connect the shield to the coil's shield in a transformer set, or to the center terminal in a filter set. The cable's "hot" lead then goes to the IC's input point. Before reassembling your TV set, check for shorts.

Once the connections have been made, mount the project top on the back panel of the set and remount the back panel on the TV set. Choose a location as far as possible from the set's horizontal output section and isolated from the metal chassis.

Now take a few moments to make a final safety check. Set your multimeter to its highest resistance range and touch one probe to the shell of the phono plug and the other probe to first one and then the other prong of the TV set's line cord. If you obtain anything but an infinity reading in either case, find the cause and correct it immediately.

Alignment

Setting up the project for proper operation is a quick and easy procedure to perform. You need an audio amplifier (with speaker) and an insulated alignment tool. Do not use a jeweler's screwdriver or any other screw-

(Continued on page 96)

MACHINE PIN SOCKET



22 PIN GOLD PLATED SOCKET
5 pcs \$1.00
Stk. #ICS-22M

CIRCUIT BOARD BONANZA



Sound generator boards removed from electronic pin-ball games. Contains oscillators, control circuits & 2 watt audio amp. Experimenters dream!!!
\$2 ea - 10/\$12.50 w/schematics

POWER SUPPLY
MFG. BY GENERAL INSTR.

INPUT 110VAC
OUTPUT +5VDC @ 5AMPS
+12VDC @ 2.5AMPS
-12VDC @ 3AMPS
PS-120 \$24.50
Used in some Commodore comp.



LOW PROFILE SOCKETS (TIN)

# OF PINS	PRICE
8	\$.08
14	\$.10
16	\$.12
18	\$.15
20	\$.18
22	\$.18
24	\$.20
28	\$.25
40	\$.30

ELECTRONIC PIEZO BEEP BUZZER
Special - 2/\$1.00
7/8" Diameter element on plating mounting. Originally used in Radio Shack telephone as the ringer.
Stk. #PZD-78 \$.75

ULTRAVIOLET TUBES GOOD FOR EPROM ERASERS
110 VAC
\$2.25 ea. - 10/\$15.00



8" DRIVE POWER SUPPLIES \$24.50



8" DISK DRIVE POWER SUPPLY
Heavy duty supply can run up to 4 drives. Enclosed frame Input 117VAC. Output 5VDC @ 7 Amps. +24VDC @ 6 Amps. -24VDC @ 6 Amps.
Stk #PS-8 \$24.50

BUILD YOUR OWN EPROM ERASER



115VAC BLACK LIGHT (ULTRA VIOLET)

ROCKER SWITCH
16 Amp On/Off
Used in Xerox 820 Computers
\$.75



5V & 12V REGULATOR BOARD
Regulator board containing 5V & 12V TO-220 regulators, fuses, bridges, caps & I/O connectors. Size 2"x4" w/heatsinks.
REG-512 \$3.50

WALL PLUG ADAPTERS
6VDC @ 300ma
\$1.75 or 10/\$12.50



ISOLATION TRANSFORMER
117VAC
117VAC @ 125VAC
MFG BY SIGNAL TRANS
\$3.00 Each 10/\$20.00



POWER SUPPLY
General purpose compact power supply. 3 outputs: +5V @ 1 Amp. +12V @ 1 Amp. & +24V @ 1 Amp. Power Transistors mounted on a heat sink 2"x4" w/transformer. Stk #PS-3P \$4.49



VITEK CABLE CONVERTER
Model No. TC-1M converter. Both Mid Band & VHF frequencies. Has built in power supply. Units are new & in working cond.
Stk. #TC-1M \$9.95



115 volt ultra violet light, with lamp, ballast and in-line cord switch. Just build enclosure to finish.
Stk. #EPB-125 \$12.50



Full Wave Bridge
6AMP-300V
2/\$1.00



RECTIFIER BOARD
Contains (4) 10 Amp bridges, (3) large filter caps. & I/O conn. Size 4.5"x8" BRDG-4 \$2.50ea or 10/\$12.50

RIGHT ANGLE HEADERS

40 Pin	\$4.00
34 Pin	\$5.00
10 Pin	\$2.25

RIBBON CABLE



1000 PIECE RESISTOR ASS'T ALL SIZES & VALUES
Stk. #RES-1000 \$3.00
for robotics, precision movement applications etc.

STEPPER MOTOR
(Unifilar Wound)
5 VDC 3 1/2 Watts 7.5°X
48 Step/Rev. 28 RPM
Stk. #MO-5 \$3.50



IBM PC-JR REPLACEMENT POWER SUPPLY



MINI-TOGGLE SWITCH
5AMP DPDT
\$.65 EA
10/\$4.50



12 VDC TOY MOTOR
Stk. #MO-12 2/\$1.00



TRANSFORMERS

STK.#	PRI (VAC)	Secondary (VAC)	Price
TN-6.3	117 6.3	@ 300ma	\$1.25
TN-12	117 12	@ 400ma	\$1.35
TN-24A	117 24	@ 200ma	\$1.25
TN-24B	117 24ct.	@ 3.6 Amp	\$3.50

9 conductor Spectrastrip with red market stripe. 250' per roll. 28ga. stranded wire. WRIB-9 \$10/Roll

UNENCODED KEYBOARD
Full size kybd w/number pad. 70 keys w/LED power indicator. Orig from dumb terminals. New!!! Mfg by Hi Tek.
Stk. #Kybd-70 \$9.95



ATARI GAMES
An assortment of 10 Atari game ROMs. Simply open any Atari cartridge & replace the existing ROM with a new one. Play another 10 games instantly.
Stk. #ROM-10 10/\$2.50



ATARI REPLACEMENT POWER SUPPLIES



SNAP ACTION SWITCH



COMPUTER GRADE CAPACITORS
Ass't of 10
Stk #CCG-10 \$2.50



HEAT SINK TO-3
\$.25



DISKETTE LOOSE LEAF HOLDER
Holds 2 5 1/4" diskettes. Has 3 hole punch to mount in standard loose leaf folder. Stk #VIN-5 10/\$2.50
For standard 8 1/2"x11"



ATARI GAME ROMS
An assortment of 10 Atari game ROMs. Simply open any Atari cartridge & replace the existing ROM with a new one. Play another 10 games instantly.
Stk. #ROM-10 10/\$2.50



COMPUTER SPEAKERS
2 25 8 ohm 25 watts
This is the same speaker that IBM uses. Excellent for computer builders.
Stk. #SPK-8 \$6.55



ELPAC POWER SUPPLY
For TV game & computer peripheral equipment. Rated 110VAC input. Output +5VDC @ 860MA +12VDC @ 300MA & -12VDC @ 300MA Model #WM-113
Stk. #WTN-113 \$6.75



DISK DRIVE MOUNTING SCREWS
20 for 50¢



CPM DISKETTE FOR USE WITH NEC V-20 PROCESSORS
\$3.75



LOAD RESISTOR FOR IBM POWER SUP.
5 Ohm @ 25 watts
\$1.79
Stk # RIBM-5



MAGNETS
2" Bar Magnet with Tape On One Side
2/\$1.00



12 POS KEY PAD
Stk # Kypd-12 \$1.50



COILED CORD BONANZA
4 Conductor coiled cord. Black vinyl jacket. Extends to 6 ft. No connectors on either end.
Stk. #CC-000 3/\$1.00
4 Conductor coiled cord. Black vinyl jacket. Extends to 6 ft. Used as keyboard cable. Phone jack to 5 pin din connector.
Stk. #CC-100 \$4.00



3 VOLT LITHIUM BATTERY
Used as battery back up on most multi-function cards.
Mallory BR 2325
\$1.00 EACH - 10/\$5.00



GOODIES!
Delta Design Table Top Temp. Chamber \$100
Altos Computer \$250
Sanyo CMP/M Computer \$250
Xerox 820-11 Comp \$550
Box of 50 pcs waveguide & antennas \$100

APPLE III MEMORY EXPANSION BDS
\$15.00
w/OK memory

DB-25 USED Connector Ass't
10/\$2.50

TANTALUM CAP ASS'T
10 pcs \$2.00



WIRE TEST PROBE WIRE
18 Gauge rubber coated. Red, black, white or blue. 100'/513
HOOK-UP WIRE
24 Gauge stranded cond. 22 gauge solid conductor. your choice. 100'/82
WIRE WRAP WIRE
30 Gauge solid cond. Choice of colors. 100'/52.50



TOCOM 55 PLUS CABLE TV CONVERTER
55 CHANNEL CONVERTER
Complete Unit - \$24.50
Mainboard - \$7.50
Power Supp - \$4.50
We Received A Large Shipment Of These Cable Converters. Good Savings!



COMPUTER CHESS GAME



MILTON BRADLEY CHESS GAME
Electronic circuit board removed from famous toy maker's game. Board has 6502 processor. 74LS series ic's, buzzer & many other useful components. Boards are complete and undamaged. MB part #7924243001
BD-792 \$3.95 ea. 10/\$24

Components Ass't Your Choice \$2.75

Stk#	Description
CD-180	Ceramic Disk Capacitors 10 pcs of 18 different values. 180 pcs total
CE-180	Electrolytic Capacitors 10 pcs of 18 different values. 180 pcs total
CM-180	Mylar Bypass Capacitors 10 pcs of 18 different values. 180 pcs total
TP-180	Miniature Trim Pots 10 pcs of 18 different values. 180 pcs total

CERAMIC DISC CAPACITOR ASS'T
200 pcs \$4.00



TV-GAME SWITCH
\$.65 EACH
OR 10/\$4.25



ULTRA-SONIC TRANSDUCER
Don't know what these came out of but this is a doozy of a device. Unit is an aluminum cylinder containing a piezo ceramic with an adjustable coil in parallel. Frequency is 24 khz. Can be used in many ultrasonic circuits.
Stk. #MULT-58 \$2.25



COLECO JOYSTICKS
\$2.50 EACH
10/\$17.00



CRYSTALS

Frequency	Case Price
4.0MHZ HC18	\$1.25
6.0MHZ HC18	\$1.25
8.0MHZ HC18	\$1.25
10.7MHZ HC18	\$0.75
14.318MHZ HC18	\$1.25
18.432MHZ HC18	\$1.25

VOLTAGE REGULATORS

7805 5v 1.5 amp	
7812 12v 1.5 amp	
7824 24v 1.5 amp	
7905 5v 1.5 amp	
7905 5v 1.5 amp	
7912 12v 1.5 amp	

\$.43 Each



LOLIR ELECTRONICS CORP.
13933 N. CENTRAL EXPRESSWAY
SUITE 212
DALLAS, TX 75243
214-234-8032 - 214-234-8056

TERMS: Check or Money Order. COD's Add \$1.90. TX Res. add 6% Tax. Please add \$3.50 shipping. All out of stock items will be refunded.



Audio Amplifier Experiments

By Forrest M. Mims III

In this era of digital electronics, it's easy to overlook the fact that one of the earliest electronic circuits is still the most widely used. That circuit is the ubiquitous audio-frequency amplifier.

Of the thousands of analog electronic circuits developed over the years, none is as versatile or possesses as much overall importance as the audio-frequency amplifier. Every public address system, radio, tape recorder, television receiver, intercom and transceiver contains at least one audio amplifier. Doctors use audio amplifiers to electronically monitor such physiological functions as respiration, pulse rate and the electrical activity of heart and brain. Scientists and engineers use them to boost the tiny signal levels from accelerometers, strain gauges, photocells and Geiger tubes. Experimenters and technicians use them to troubleshoot audio-frequency circuits (signal tracing) and for general-purpose experimenting.

Since audio amplifiers are so commonplace, it's easy for those people who lack electronic construction skills to perform experiments with them. Of course, experienced experimenters may prefer to build their own custom amplifiers, perhaps including features not ordinarily found in commercial models. In this column, I'll describe several kinds of commercial amplifiers and a do-it-yourself version you can easily assemble. Then I'll describe several experimental applications and suggest others.

Suitable Amplifiers

The experiments to be described and many others can be easily performed with a low-cost commercial amplifier such as Radio Shack's Mini Amplifier-Speaker. This compact battery-powered amplifier, which sells for about \$12, has a frequency response of 100 Hz to 10 kHz. It has a sensitivity of 1 millivolt and an output power of 200 milliwatts. The amplifier is equipped with a volume control and separate 1/8-inch phone jacks for the input and output, the latter to an external speaker or earphone.

Some portable cassette tape recorders

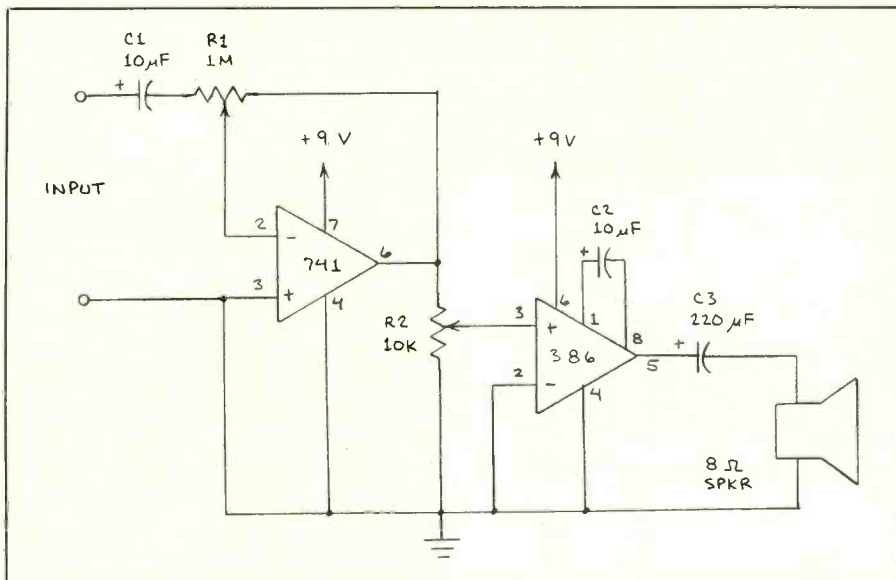

Fig. 1. A do-it-yourself audio amplifier.

can also function independently as audio amplifiers. They offer the added benefit of permitting you to record unusual sounds or signals you happen to detect.

Many other commercial amplifiers can also be used. Especially well suited are public address (PA) systems and component amplifiers for home high-fidelity systems. Keep in mind, however, that portable battery-powered amplifiers provide much more flexibility. They also present no electrical shock hazard.

Some amplifiers are equipped with tone controls, but many are not. I've had excellent results by connecting a miniature, battery-powered equalizer between a battery-powered amplifier and an external earphone. The equalizer can substantially reduce the amplitude of both low-frequency noise (such as 60-Hz line noise) and high-frequency noise, emphasizing the audio frequencies to which the ear is most sensitive.

Caution: No matter what kind of amplifier you select, it is essential to use a great deal of caution if you use any kind of earphone to monitor the amplified signal. Sound levels produced by an earphone connected to even a small battery-powered amplifier might be sufficiently loud to cause temporary or even permanent loss of hearing.

When using an earphone, *always* rotate

the volume control to the quietest position *before* placing the phone in or against your ear. Then gradually increase the volume to an appropriate level. Always be careful to avoid high input signal levels when the earphone is in or near your ear.

Do-It-Yourself Amplifier

Many readers may prefer to build their own amplifier to perform the experiments that follow. Therefore, before presenting the experiments, I'll begin by describing an easily assembled basic do-it-yourself amplifier.

Figure 1 is the schematic diagram for the amplifier. The input signal is coupled into the inverting input of a 741 operational amplifier. Other op amps can also be used. Gain control $R1$ doubles as both the input and feedback resistor. The amplified signal is fed into an LM386 power amplifier through $R2$, which serves as a volume control. The output from the LM386 drives an 8-ohm speaker through $C3$. An 8-ohm earphone can be substituted for the speaker. Capacitor $C2$ sets the gain of the LM386 to 200. (Gain can be reduced to 20 by omitting $C2$.)

For best results, keep connection leads of the circuit short and direct to minimize amplifier noise level and the possibility of

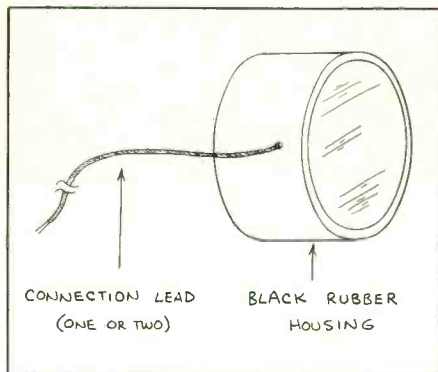

Fig. 2. A surplus hydrophone.

inductive feedback that can cause the amplifier to oscillate at high gain levels. To further reduce the possibility of oscillation, connect a 0.1-microfarad capacitor across the power supply pins of the two integrated circuits.

Underwater Hydrophone

Of the many experiments I've performed with audio amplifiers, listening to underwater sounds has been among the most interesting. When I was a high school student, some of my friends and I used a transistorized amplifier salvaged from a cheap battery-powered PA system to establish a voice link between the deck and the bottom of a local swimming pool. One of us would swim down to the bot-

tom with the microphone while the others remained on top to listen. As you might expect, the words were bubbly sounding, but it was actually possible to understand most of what was being said.

Later, I used this same system to listen to the sounds produced by a captive porpoise. For both experiments, the microphone was a low-cost crystal unit placed inside a mostly waterproof plastic bag.

Recently, my interest in underwater sounds was revived as I was flipping through the pages of Edmund Scientific's catalog and spotted a surplus hydrophone (catalog No. 41,759) for \$9.95. I promptly ordered one.

As its name implies, a hydrophone is a microphone specifically designed for underwater use. The Edmund Scientific unit is completely encapsulated in black rubber and plastic and can be used in fresh or salt water to a 300-foot depth. The unit has a low impedance and a capacitance of approximately 15,000 pF. The hydrophone's frequency response ranges from 10 to 6,000 Hz \pm 4 dB (\pm 1 dB from 10 to 2,000 Hz). Above 7,000 Hz, the hydrophone's rolloff is at a rate greater than 12 dB per octave.

Figure 2 is a sketch of the hydrophone I purchased from Edmund Scientific. According to the specification sheet, this hydrophone may have one or two pairs of leads. If present, the additional pair of

leads facilitates connecting from two to four units in parallel. Indeed, you can buy a string of parallel-connected hydrophones from Edmund for \$39.95.

If the hydrophone you receive has an extra pair of leads, it's important to insulate the exposed end of the unused pair to prevent any possibility of inadvertently shorting the hydrophone's output. A small blob of silicone sealant like that used to assembled tropical fish aquariums works well.

The specification sheet supplied with the hydrophone explains how to solder a shielded cable to the hydrophone's leads. To avoid using the tape suggested in the spec sheet, I used a slightly different method. First, I exposed the two strands of bare wire in the connection lead and folded one strand back along the insulated lead. I then placed the exposed conductors at the end of a length of shielded cable alongside the two strands, as shown in Fig. 3.

After soldering the hydrophone's exposed leads to the shielded cable, I placed a short length of heat-shrinkable tubing over the connection and shrank it snugly over the soldered wires with the heat from a soldering iron. Next, I coated the entire connection with silicone sealant. Finally, I soldered a shielded $\frac{1}{8}$ " phone plug to the unused end of the shielded cable.

For best results, the hydrophone should be securely mounted to a suitable handle, rod or pole. Otherwise, the strain placed on the connection lead may cause one or both of the small wires to separate. Edmund Scientific's specification sheet recommends using a hose clamp to attach the body of the hydrophone to the flattened end of a length of electrical conduit (available from a hardware store). The connection leads should then be tied or taped at intervals along the pole.

In some preliminary tests, I've used my hydrophone to listen to the sounds in the spring-fed creek that flows about 1,000 feet from the old Texas farmhouse where these words are being entered into a word processor. This stream is populated by catfish, bass, blue gill, gar and various kinds of turtles and frogs. Though these tests were conducted during January when the creek's inhabitants are much less in evidence, I could hear a cacophony

Fig. 3. Connecting a shielded cable to the hydrophone.

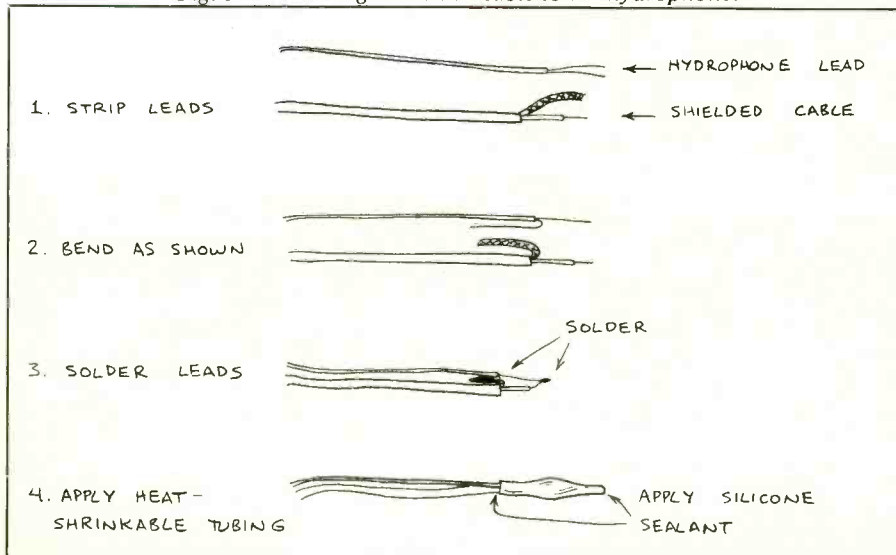

of pops, crunches, gurgles and the like. Even when the hydrophone was submerged in some of the deeper holes (8 to 10 feet), the sound of a twig tossed in the water could be clearly heard. Rain produced a static-like sound.

When the weather warms up, I plan to spend a good deal of time exploring the creek with my hydrophone. I also plan to take it out on some nearby lakes and to dip it in the waters of Corpus Christi bay on the Texas gulf coast. Finally, I plan to use the hydrophone in conjunction with a miniaturized electronic insect simulator. The latter device is a piezoelectric buzzer driven by an oscillator whose frequency rate can be altered. If the results from these experiments are interesting, I'll report on them in a future column.

Caution: For your own protection, never use a line-powered amplifier around water. To do so may result in a dangerous or even fatal electrical shock. The hydrophone experiments described here should be conducted with a battery-powered amplifier only.

Light and Lightning Detection

Another fascinating application for an audio amplifier is to monitor various light sources by means of a low-cost solar cell, photodiode or phototransistor connected to the amplifier's input. Figure 4 shows various ways each of these devices can be connected to an amplifier.

You can use any of the various photo-detector/amplifier combinations in Fig. 4 to transform into sound the pulsations or intensity fluctuations of any light source that is modulated at an audible frequency. For example, positioning the detector in the shadow of a hovering humming bird will cause the speaker connected to the amplifier to emit a tone that corresponds to the frequency of the bird's wing beats. A similar effect can be observed by positioning the detector so that it can receive flashes of sunlight reflected from the wings of flying insects.

You can also use any of the basic arrangements in Fig. 4 to monitor electrically or electronically modulated artificial light sources. All light sources directly powered by 60-Hz line current are modulated and will therefore cause an audio-

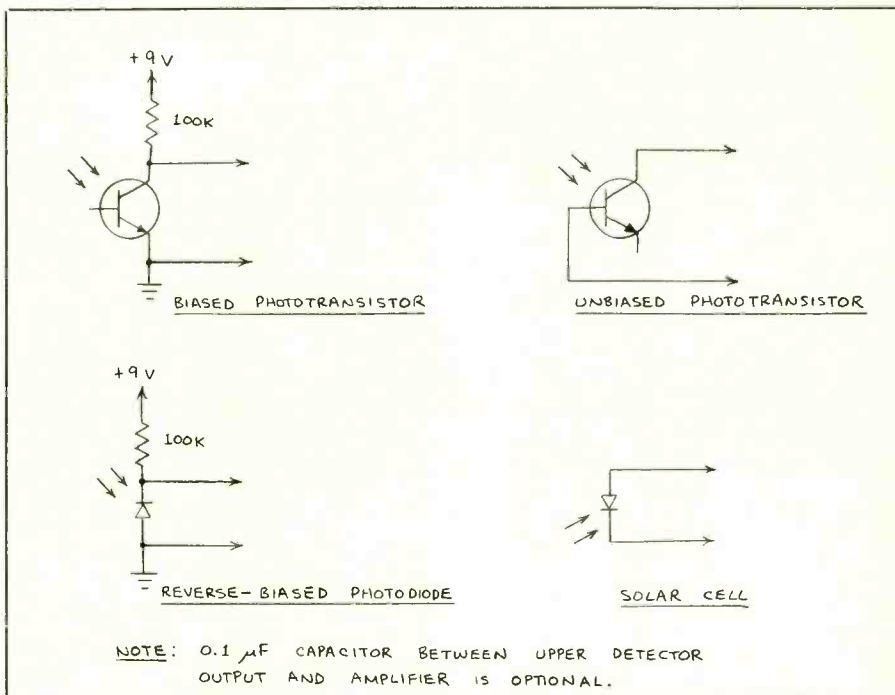

Fig. 4. Light-sensor/amplifier combinations.

frequency tone to be produced by the photodetector/amplifier combination. Multiplexed light-emitting diode (LED) displays will elicit a similar effect.

If the light source emits invisible near-infrared, a lightwave receiver is particularly handy. It can determine whether or not the source is activated and is illuminating a given area. I often use a photodiode/amplifier arrangement as an optical-fiber continuity checker. The emission from a near-IR LED pulsed at an audible frequency is injected into one end of the fiber and the photodiode monitors the opposite end. Of course the continuity of short lengths of fiber can be visually checked with a visible source.

Some applications for a light-sensing amplifier are less obvious. For instance, the tungsten filaments in some car and truck headlights will vibrate when the vehicle rolls over a rough surface. This causes the filament to move in and out of the focal point of the lamp's parabolic reflector. The result is that the beam from the light is intensity modulated. The gong and bell-like sounds that result when these intensity fluctuations are detected by a light-sensitive amplifier are quite dis-

tinctive. You can produce a similar sound by striking the end of a flashlight with a pencil while illuminating a detector connected to an amplifier.

Of the many applications for a light-sensing amplifier, my favorite is lightning detection. An ordinary AM radio indicates the presence of lightning by producing crackling and popping sounds. A light-sensing amplifier responds to lightning by producing similar crackles and pops. The major difference is that the light-sensing amplifier is directional. It can also detect lightning that is obscured by clouds and is, therefore, not ordinarily visible to the human eye. For best results, try detecting lightning at night. Be sure to avoid placing yourself in a location that might be vulnerable to a lightning stroke!

Simple Photophone

On February 19, 1880, Alexander Graham Bell and his lab assistant, Sumner Tainter, became the first people to speak over a beam of light. For this historic demonstration they directed a beam of reflected sunlight through a pair of comb-like grids made by scratching parallel

lines in the silver coating of two small glass mirrors. One grid was mounted in a fixed position, the other attached to the diaphragm of a modified telephone microphone. When voice energy was directed against the diaphragm, the grid to which it was attached moved back and forth in response to the signal. This caused a representative fluctuation in the sunlight passing through the two grids. The fluctuating light was detected by a homemade selenium light detector designed by Bell.

Professor Bell called his pioneering lightwave communicator the "photophone." In the first version, described above, the detector was separated from the grids by only a few centimeters. Soon afterward, Bell and Tainter were talking over beams of sunlight at distances of hundreds of feet. For many of these experiments they used a transmitter so simple it can be assembled by a child.

Figure 5 shows construction details of a modern version of one of Bell's photophones. Bell's version used a very thin glass mirror attached to the end of a speaking tube. The mirror became alternately convex and concave in response to the pressure of sound waves, causing the divergence of the beam of sunlight reflected from the mirror to vary accordingly. Consequently, the intensity of the beam at a distant point was amplitude or intensity modulated by the spoken words.

There are many ways to fashion a transmitter for a do-it-yourself photophone. The one shown in Fig. 5 is made by attaching a sheet of aluminum foil (shiny side out) to one end of a hollow tube. The tube can be cardboard, plastic or metal. The foil can be attached with tape or a rubber band. Aluminized Mylar provides a smoother, flatter surface than aluminum foil, projecting a narrower beam than that reflected from an aluminum foil transmitter. Unfortunately, aluminized Mylar is partially transparent and, therefore, has less reflectance than aluminum foil.

The receiver for a homemade photophone can use any of the light sensors mentioned above. For best results, however, use a silicon solar cell. The large surface area of this detector provides excellent collection efficiency without requiring an external lens. Since the photophone is designed to be used in daylight, it's important to increase the signal-to-noise (S/N) ratio by installing the cell in one end of a hollow tube. For best results, spray the inside of the tube with flat black paint or line the tube with black construction paper.

To use the photophone, simply reflect a spot of sunlight toward the detector. While holding the transmitter as still as possible, speak into its open end. The person at the receiver end should then hear every word you speak. The quality of

Fig. 5. A basic photophone system.

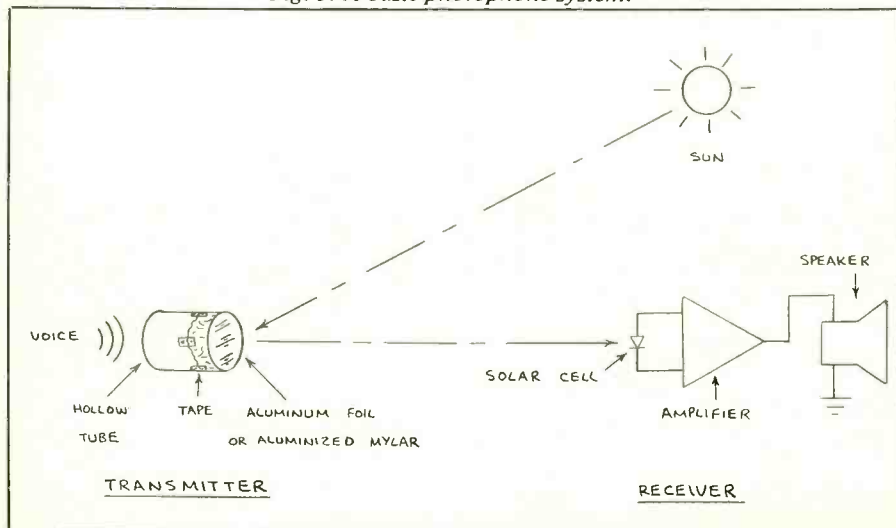

AMAZING SCIENTIFIC and ELECTRONIC DEVICES

LASER DEVICES

- LC5 BURNING CUTTING CO2 LASER \$20.00
- RUB3 RUBY LASER RAY PISTOL 20.00
- LRG3 IIR LASER RIFLE/PISTOL 10.00
- LGU3 VISIBLE RED LASER RIFLE 10.00
- LBT1 LIGHT BEAM COMMUNICATOR 10.00
- LHC2 BEGINNER simulated VISIBLE LASER 5.00

SCIENTIFIC & ELECT

- TCL3 SOLID STATE TESLA COIL 35KV 7.00
- BTC3 250 THOUSAND VOLT TESLA COIL 10.00
- BTC5 1.5 MILLION VOLT TESLA COIL 15.00
- GRA1 GRAVITY GENERATOR 10.00
- IOG3 ION RAY FORCE FIELD GUN 10.00
- PTG1 PLASMA TORNADO GENERATOR 10.00

ULTRASONIC ACCOUSTICAL

- PPF1 PHASOR PAIN FIELD GENERATOR 15.00
- PSP3 PHASOR SHOCK WAVE PISTOL 8.00
- IPG5 POCKET PAIN FIELD GENERATOR 8.00
- RAT2 RAT AND PEST ELIMINATOR 7.00
- HT9 HIGH FREQ LISTENING DEVICE 8.00

SECURITY & PROTECTION

- BLS1 BLASTER WAND 10.00
- PPG1 PHASOR PROPERTY GUARD 15.00
- MFT1 MINI VOICE XMTR 2-3 MILE 7.00
- INF1 INFINITY TRANSMITTER 15.00
- STG1 STUN AND PARALYZING GUN 7.00
- SD5 SEE-IN-DARK NIGHT EYE 10.00

WE STOCK ALL PARTS NECESSARY FOR CONSTRUCTION OF THE ABOVE PROJECTS

• CATALOG CONTAINING HUNDREDS MORE OF ALL NEW AMAZING and FASCINATING PLANS EASY TO BUILD KITS AND ASSEMBLED ITEMS \$1.00 CATALOG INCLUDED FREE WITH ANY OF THE ABOVE PROJECT PLANS. SEND CASH, CHECK, MO, VISA, MC TO:

INFORMATION UNLIMITED

P.O. BOX 716, DEPT. ME3, AMHERST, NH 03031

CIRCLE 62 ON FREE INFORMATION CARD

cable tv DESCRAMBLER PARTS

We stock the exact parts. PC Board and A.C. Adaptor for an article published in Radio Electronics Magazine (Feb., 1984) on building your own CABLE TV DESCRAMBLER.

#701 PARTS PACKAGE \$29.95

Includes all the original resistors, capacitors, diodes, transistors, integrated circuits, coils and IF transformers.

#702 PC BOARD \$12.95

Original etched & drilled silk-screened PC Board used in the article.

#704 AC ADAPTOR \$12.95

(14 volts DC @ 285MA)

Both #701 & #702 \$39.00

#701, 702 & 704 \$49.00

FREE!! Reprint of Radio Electronics Article on Building Your Own Cable TV Descrambler with any purchase.

Add \$2.50 Shipping & Handling
\$4.50 for Canadian Orders

ORDER TOLL FREE
1-800-227-8529

Visa, MasterCard or C.O.D.

J & W ELECTRONICS, INC.

P.O. Box 800Z
Mansfield, MA 02048

CIRCLE 30 ON FREE INFORMATION CARD

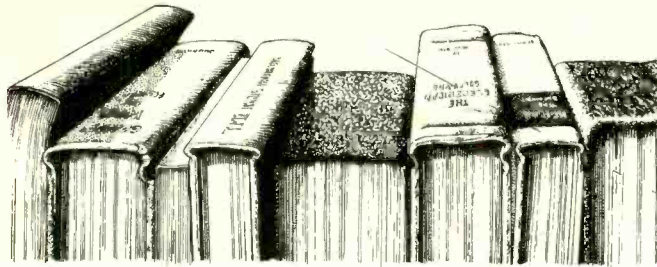

Designing Electronic Circuits by Robert G. Middleton. (Prentice Hall. Hard cover. 351 pages. \$29.95.)

As electronics design-type books go, this one is a good cut above what is usually available. It does not overwhelm the reader with unnecessarily heavy text detail and it provides wide coverage. Essentially, this handbook of procedures and reference data gets you immediately down to the task of designing discrete-transistor circuits. Limiting mathematics to basic algebra, the book focuses on practical circuit design procedures through terse text, formulas and liberal use of schematics and other diagrams.

Each of the 13 chapters in this book tackles a different amplifier topic—basic amplifiers, audio preamps, driver and power amplifiers, tuned amplifiers, wide-band amplifiers, and basic MOSFET amplifiers, to name just a few. Each successive topic builds on previous topics to provide unified coverage.

An interesting feature of this book are the more than 60 BASIC programs (written for the IBM PC and compatibles but with information in an appendix that tells you how to convert them for the Commodore 64 and Apple II computers). You key in these programs and then have a computer do most of the preliminary design calculations. The computer-aided design programs are a nice touch that we would like to see more of in electronics books. In sum, this is a practical, valuable book for anyone interested in designing circuits.

Pocket Digital Multimeter Techniques by Homer L. Davidson (Tab Books. Soft cover. 360 pages. \$22.95.)

The omnipresent digital multimeter (DMM) is usually the most versatile instrument one can own. This book focuses on its many uses, emphasizing quick and easy methods to troubleshoot almost any electronic device. For example, in addition to making garden-variety voltage, current and resistance measurements and simple continuity tests that can be conducted with the DMM, you are shown how to make critical measurements and how to use these to pursue a realistic repair procedure.

To demonstrate what can be done with a DMM, each chapter deals with troubleshooting of a different electronic product. Among the products used as illustrative examples are a variety of TV receiver types, portable and table-model radios, AM/FM-stereo receivers, stereo amplifiers, 8-track and cassette decks, car and truck radios, and telephones. Within each chapter is a list of the most common problems that may occur in the product under discussion, plus several case histories that help illustrate how to isolate the cause of a problem, make certain tests, locate and repair problems. In fact, a significant part of this book deals with symptom/cause/correction of electronic circuit problems, noting voltage and resistance differences. Thus, the book is really a troubleshooting guide using a DMM or any other type of multimeter, rather than a pocket DMM in particular. The title of the book is therefore inappropriate. Nonetheless, the book itself is a veritable course on examples of what can go wrong in a circuit and how to troubleshoot with only a multimeter.



There's Always One Catalog You Can Count On— **MCM ELECTRONICS!**

You want a company you can depend on for quality.

You want a company that's famous for fast service.

And you want a company that's known for great, low prices.

What you want is **MCM Electronics.**

Because if you want to get the best out of your business, it only makes sense to order from the best.

Nobody will serve you better.

CATALOG #11 NOW AVAILABLE

**CALL TOLL FREE
1-800-543-4330**

(IN OHIO, 1-800-762-4315)
(IN ALASKA AND HAWAII, 1-800-858-1849)



MCM ELECTRONICS
A DIVISION OF PREMIER INDUSTRIAL
858 E. Congress Park
Centerville, OH 45459

CIRCLE 27 ON FREE INFORMATION CARD SOURCE NO. ME-8

Faster Than a Reading Bullet

By Art Salsberg

With so much to read and so little time to do it, anything to speed up the process would be very helpful. That's where "speed reading" courses come in. To many people this conjures up Evelyn Woods' speed-reading seminars, popularized during President John Kennedy's administration, which is going stronger than ever today.

I had taken a compulsory speed-reading course many years ago when I studied electronics. It was called the "Harvard Speed Reading" course and used audio-visual methods that were very effective. Doubling one's reading speed after completing the course was commonplace. Many students, including me, greatly exceeded this modest increase.

Examining CBS Software's *Micro-SpeedRead*, a \$125 four-disk program with an accompanying softcover user's manual (over 200 pages), revealed that the same basic teaching principles were used as in my audio-visual course many years ago. Accordingly, it should certainly have the potential for significantly increasing a user's reading speed. The program is designed for use with an IBM PC or compatible that uses DOS 1.1 or higher, an IBM PCjr (requiring DOS 2.1 and its BASIC cartridge), and Apple II+ /IIe/IIc computers. Only one disk drive is needed.

The disk operating system must be loaded first, followed by loading of BASIC. Then the program disk is substituted. There are ten lessons in all, with the first lesson enabling you to estimate your present speeds. Note the plural, *speeds*. You will find that there is a standard reading speed, a reading speed when you're pushing for greater speed, and skimming and scanning speeds.

Pressing the space bar to start and stop the computer's automatic scoring of your reading speed when you read material in the manual gives you a clear indication of how fast (or slow) you read when starting the speed-reading course.

Remaining lessons develop your reading speed and comprehension abilities, followed by refining your skills through prac-

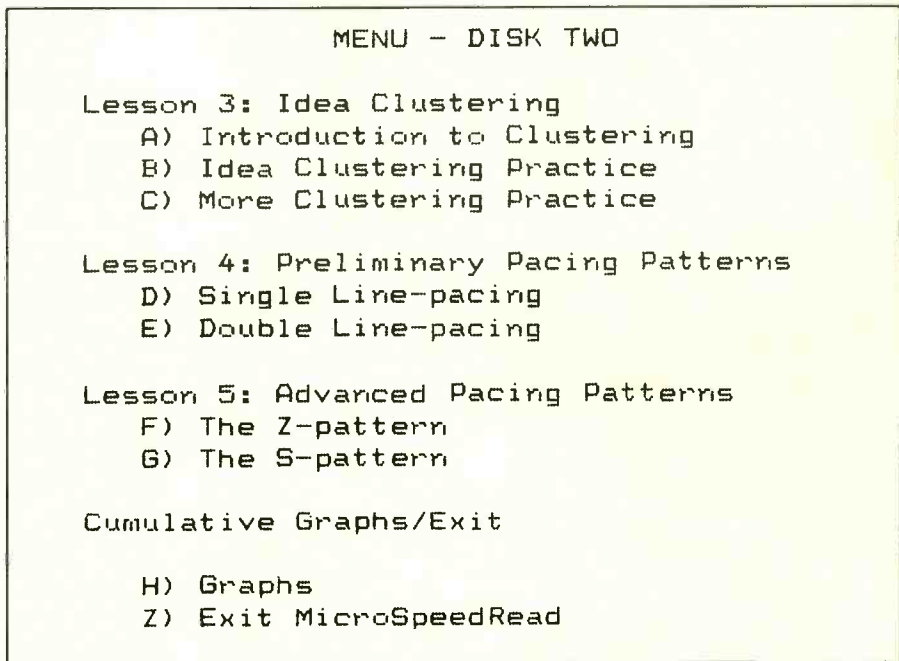

Fig. 1. Sample menu.

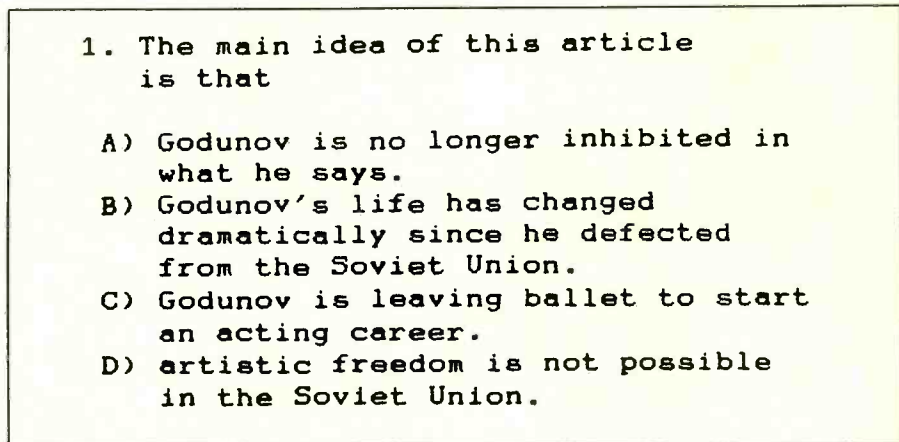

Fig. 2. Sample comprehension test.

tice. High reading speed is useless unless you retain what you read, of course. So the little exams that follow check you out on reading retentivity.

The video display challenges you by moving from sentence to sentence in varying speeds that you choose or by limits you set on how long text remains on screen. You'll be startled at first by your inability to read or comprehend much at the higher speeds you'll want to try your hand (eyes)

on at the start. But if you stick with the course, I'm confident that all but the really high speeds will be handled quite well.

It's a case of practice makes better, aided by neat reading tips for speeding your way through articles and books. This type of speed reading, or any other type, is not designed to provide one with great reading pleasure. You don't chew words

(Continued on page 90)

RAMSEY

THE FIRST NAME IN ELECTRONIC TEST GEAR



\$30⁰⁰ OFF

Save \$30 on the RAMSEY 20MHz Dual Trace Oscilloscope

Unsurpassed quality at an unbeatable price, the Ramsey oscilloscope compares to others costing hundreds more. Features include a component testing circuit for resistor,

capacitor, digital circuit and diode testing • TV video sync filter • wide bandwidth & high sensitivity • internal graticule • front panel trace rotator • Z axis • high sensitivity x-y mode • regulated power supply • built-in calibrator • rock solid triggering

Was \$399.95 NOW ONLY **\$369.95** high quality hook on probes included



NEW RAMSEY 1200 VOM MULTITESTER

Check transistors, diodes and LEDs with this professional quality meter. Other features include: decibel scale • 20K volt metering system • 3 1/2" mirrored scale • polarity switch • 20 measuring ranges • safety probes • high impact plastic case

\$19.95 test leads and battery included



NEW

RAMSEY D-4100 COMPACT DIGITAL MULTITESTER

Compact sized reliability and accuracy. This LCD digital multitester easily fits in your pocket, you can take it anywhere. It features full overload protection • 3 1/2 digit LCD readout • recessed input jacks • safety probes • diode check function • 2000 hours battery life

\$22.95 test leads and battery included

NEW 35 MHz DUAL TRACE OSCILLOSCOPE

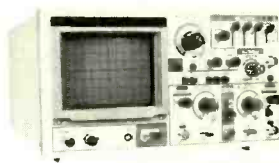

A heavy duty and accurate scope for service as well as production use. Features include • wide frequency bandwidth • optimal sensitivity • extremely bright display • delayed triggering sweep • hold off • ALT trigger • single sweep • TV sync • 5X magnification • XY or XYZ operation • HF/LF noise reduction

3500 Dual Trace Oscilloscope \$499.95 includes 2 high quality probes

ALL OSCILLOSCOPES INCLUDE 2 PROBES

NEW 15 MHz DUAL TRACE PORTABLE OSCILLOSCOPE

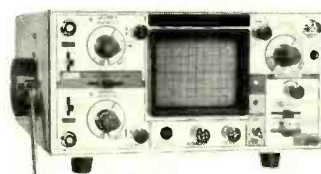

Ideal for field/bench applications, this scope can display up to 15 MHz signals. Internal battery pack allows up to 2 hours operation on a single charge. Features include • built-in battery charger • 5X horizontal magnification • high brightness CRT • front panel trace rotator • internal rechargeable battery pack

2500 Portable Oscilloscope \$449.95 includes 2 high quality probes

MINI KITS—EASY TO ASSEMBLE, FUN TO USE BEGINNERS & PROS WILL HAVE A GREAT TIME WITH THESE KITS

FM MINI MIKE



A super high performance FM wireless mike kit! Transmits a stable signal up to 300 yards with exceptional audio quality by means of its built in electret mike. Kit includes case, mike, on-off switch, antenna, battery and super instructions. This is the finest unit available.

FM-3 Kit \$14.95
FM-3 Wired and Tested 19.95

Color Organ
See music come alive! 3 different lights flicker with music. One light each for, high, mid-range and lows. Each individually adjustable and drives up to 300 W. runs on 110VAC.

Complete kit, ML-1 \$8.95

Video Modulator Kit
Converts any TV to video monitor. Super stable, tunable over ch 4-6. Runs on 5-15V accepts vid. video signal. Best unit on the market! Complete kit, VD-1 \$7.95



Led Blinky Kit
A great attention getter which alternately flashes 2 jumbo LEDs. Use for name badges, buttons, warning panel lights, anything! Runs on 3 to 15 volts. Complete kit, BL-1 \$2.95

Super Sleuth
A super sensitive amplifier which will pick up a pin drop at 15 feet! Great for monitoring baby's room or as general purpose amplifier. Full 2W rms output, runs on 6 to 15 volts, uses 8-45 ohm speakers. Complete kit, BN-9 \$5.95

CPO-1
Runs on 3-12 Vdc 1 watt out, 1 KHZ good for CPO. Alarm, Audio Oscillator. Complete kit \$2.95

FM Wireless Mike Kit
Transmits up to 300' to any FM broadcast radio, uses any type of mike. Runs on 3 to 9V. Type FM-2 has added sensitive mike preamp stage.

FM-1 Kit \$3.95 FM-2 Kit \$4.95



Whisper Light Kit
An interesting kit, small mike picks up sounds and converts them to light. The louder the sound, the brighter the light. Includes mike, controls up to 300 W, runs on 110 VAC. Complete kit, WL-1 \$6.95

Tone Decoder
A complete tone decoder on a single PC board. Features: 400-5000 Hz adjustable range via 20 turn pot, voltage regulation, 567 IC. Useful for touch-tone burst detection, PSK, etc. Can also be used as a stable tone encoder. Runs on 5 to 12 volts. Complete kit, TD-1 \$5.95



Siren Kit
Produces upward and downward wail characteristic of a police siren. 5 W peak audio output, runs on 3-15 volts, uses 3-45 ohm speaker. Complete kit, SM-3 \$2.95

Universal Timer Kit
Provides the basic parts and PC board required to provide a source of precision timing and pulse generation. Uses 555 timer IC and includes a range of parts for most timing needs.

UT-5 Kit \$5.95

Mad Blaster Kit
Produces LOUD ear shattering and attention getting siren like sound. Can supply up to 15 watts of obnoxious audio. Runs on 6-15 VDC. Complete kit, MB-1 \$4.95

60 Hz Time Base
Runs on 5-15 VDC. Low current (25ma) 1 min/month accuracy 1B-7 Kit \$5.50 TB 7 Assy \$9.95

30 Watt 2 mtr PWR AMP

Simple Class C power amp features 8 times power gain. 1 W in for 8 out, 2 W in for 15 out, 4 W in for 30 out. Max output of 35 W, incredible value, complete with all parts, less case and T-R relay.

PA-1, 30 W pwr amp kit \$22.95
TR-1, RF sensed T-R relay kit 6.95

Power Supply Kit

Complete triple regulated power supply provides variable 6 to 18 volts at 200 ma and +5 at 1 Amp. Excellent load regulation, good filtering and small size. Less transformers, requires 6 3W (a 1 A and 24 VCT. Complete kit, PS-3LT \$6.95

CT-70 7 DIGIT 525 MHZ COUNTER

Lab quality at a breakthrough price. Features • 3 frequency ranges each with pre amp • dual selectable gate times • gate activity indicator • 50mV @ 150 MHz typical sensitivity • wide frequency range • 1 ppm accuracy

\$119.95 wired includes AC adapter
CT-70 kit \$99.95
BP-4 nicad pack 8.95

CT-50 8 DIGIT 600 MHZ COUNTER

\$169.95 wired
CT-50 kit \$139.95
RA-1 receiver adapter kit 14.95

CT-90 9 DIGIT 600 MHZ COUNTER

The most versatile for less than \$300. Features 3 selectable gate times • 9 digits • gate indicator • display hold • 25mV @ 150 MHz typical sensitivity • 10 MHz timebase for WWV calibration • 1 ppm accuracy

\$149.95 wired includes AC adapter
CT-90 kit \$129.95
OV-1 0.1 PPM oven timebase \$9.95
BP-4 nicad pack 8.95

CT-125 9 DIGIT 1.2 GHZ COUNTER

\$169.95 wired includes AC adapter
BP-4 nicad \$8.95

DM-700 DIGITAL MULTIMETER

Professional quality at a hobbyist price. Features include 26 different ranges and 5 functions • 3 1/2 digit, 1/2 inch LED display • automatic decimal placement • automatic polarity

\$119.95 wired includes AC adapter
DM-700 kit \$99.95
MP-1 probe set 4.95

PR-2 COUNTER PREAMP

The PR-2 is ideal for measuring weak signals from 10 to 1,000 MHz • flat 25 db gain • BNC connectors • great for shifting RF • ideal receiver/TV preamp

\$44.95 wired includes AC adapter
PR-2 kit \$34.95

PS-2 AUDIO MULTIPLIER

The PS-2 is handy for high resolution audio resolution measurements, multiplies up in frequency • great for PL tone measurements • multiplies by 10 or 100 • 0.01 Hz resolution & built-in signal preamp/conditioner

\$49.95 wired
PR-2 kit \$39.95

PS-10B 1.5 GHZ PRESCALER

Extends the range of your present counter to 1.5 GHz • 2 stage preamp • divide by 1000 circuitry • super sensitive (50 mV typical) • BNC connectors • 1 GHz in, 1 MHz out • drives any counter

\$79.95 wired includes AC adapter

ACCESSORIES FOR RAMSEY COUNTERS

Telescopic whip antenna—BNC plug \$ 8.95
High impedance probe, light loading 16.95
Low pass probe, audio use 16.95
Direct probe, general purpose use 13.95
Tilt bail, for CT-70, 90, 125 3.95

PHONE ORDERS CALL **716-586-3950**
TELEX 466735 RAMSEY CI

TERMS: • satisfaction guaranteed • examine for 10 days; if not pleased, return in original form for refund • add 6% for shipping and insurance to a maximum of \$10.00 • overseas add 15% for surface mail • C.O.D. add \$2.50 (C.O.D. in USA only) • orders under \$15.00 add \$1.50 • NY residents add 7% sales tax • 90 day parts warranty on all kits • 1 year parts & labor warranty on all wired units.

RAMSEY

RAMSEY ELECTRONICS, INC.
2575 Baird Rd.
Penfield, N.Y. 14626

New electronic memory chips, a new microprocessor chip, the UART defined & some circuits, how drawings are made

By Don Lancaster

We'll once again start out with our usual reminder that this is your column and you can get solutions to many of your "Hardware Hacker" questions per the phone and address in the ending box.

Since there's lots of exciting new hacker components this month, let's just jump right in.

What's new in electronic memory?

So much is happening so fast it is hard to keep up. Let's look at three new developments:

First, if you check the ads right here in *Modern Electronics*, you will find 256K dynamic RAMs available for a mere \$3 each, give or take a few cents. That's almost *one millicent* per bit!

What utterly boggles the mind is that if "they" keep increasing memory size and keep reducing the per-bit price at the same rate "they" have for the past 14 years, you will have the equivalent of the 5-billion neurons in the human brain on a single chip for under a dollar before the end of the century!

Second, Apple has a new RAM card that holds a full megabyte of memory and fits either a II+ or IIe. The card automatically supports both the DOS 3.3 and ProDOS operating systems. You can use as many cards as you need, up to a total of seven or eight megabytes. Plus the 64K or 128K you started out with.

I've started using this card and I like it very much. It is destined to become the primary standard for Apple add-on memory cards. Why? Because it (a) comes from the "company," and (b) does *not* use awkward and ungainly bank switching. Instead, the entire card is readable from one single address that auto-increments.

I have put together a disassembly script and a few utilities that make this card more understandable and far easier to use. Write or call if you need more on this.

Third, Both NEC and OKI have some new memory modules out that show outstanding potential for the advanced hardware hacker.

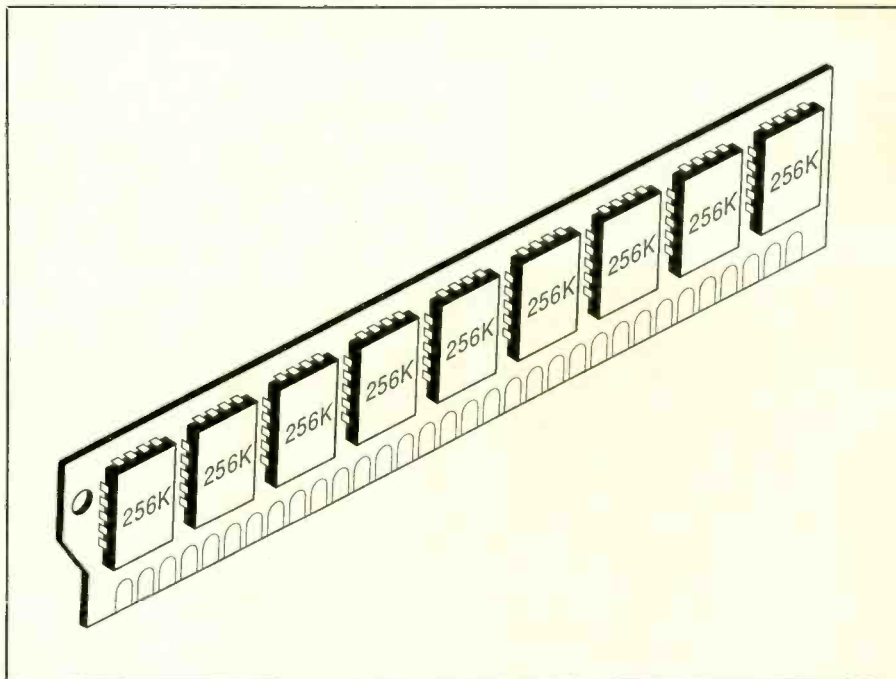

Fig. 1. A module with nine 256K RAM chips costs \$24 in single quantity.

As Fig. 1 shows, these modules consist of a fancy printed-circuit board and nine 256K dynamic RAMs in a small plug-in unit. The ninth RAM can be used either for error testing or as a spare that gets jumpered if another RAM chip fails.

Besides being much smaller than traditional DIP packaging, these new modules are removable and contain internal supply bypass capacitors. They are almost certain to become the RAM of choice for the next generation of microcomputers.

OKI will sell you *two* 256K \times 1 modules and a special double socket for only \$48 in singles. That's right at the magic millicent per bit figure. Its called the DRAM SIMM Sample Set, and is available right now. Before you get all excited, though, note that these are strictly for advanced hackers only. There are serious hassles involved in using any dynamic RAM. You have to know where the address lines are going to come from to address an entire 256K block of words. You have to know how you are going to refresh the RAM chips to keep the memory alive. And, you have to know how to handle address pin multiplexing where one package pin is used at different

times for either a column address or a row address.

Nonetheless, these RAM modules should drop into a Macintosh with a minimum of hassles or rework. More information on dynamic RAM appears in my newly reprinted *Micro Cookbook*, Volume I (SAMS #21828).

Any new micros this month?

I just ran into a really exciting new microprocessor chip that should be ideal for almost any small controller, trainer, or data gathering use. This chip has hacker written all over it.

Its called the Mitsubishi M50734 and sells for \$12 in single. It is built-in CMOS and speaks 6502, so it should be really easy to use with Apples, Commodores, Ataris, and the rest of the 6502 gang. Internal bank switching is used to create a double-sized 128K address space.

No RAM or ROM inside, but my oh my, the ready-for-use peripheral circuitry stuffed into this beast. How does 40 I/O lines, a Centronics port, nine timers, a multiple input A/D converter, some step-

per motor drivers, a pulse position modulator, and a two-way UART serial communications channel interface sound? If that's not enough for you, there are enough pins on the package that you can also use it for an emergency cheese grater.

Obvious uses for the M50734 include data recorders, hydrophonic garden timers, cable TV intelligent taps, solar-powered pump interfaces, general robotics, weight scales, cattlefeeder setups, student trainers, hot-tub pump cyclers, cotton-picker tooth setter, numeric machine controls, etc.

It might even be possible to drop this dude and an adapter directly into the 65C02 socket on an Apple IIc or IIe and run everything else out of a humongous new I/O connector. Stay tuned to this column for more details.

The beauty of being more or less Apple compatible is that the full resources of the Apple become available for design, debugging, and testing of what you want to do. No costly ROM masks or emulation software is needed, and the design process is fast and fun by using standard assemblers, debuggers, printers, disk drives, etc.

Two minor gotchas. The 64-pin, 70-mil shrink DIP package is oddball, so sockets may be very difficult to find. In addition, there are not enough pins to go around, so they used Motorola style pin multiplexing on the data/low address lines. At worst, this means you have to add a 74HC373 address latch to your final circuit.

You'll find lots of information on programming 6502-style chips like the M50734 in my two *Micro Cookbooks* SAMS #2128 and 21829).

Tellyawhat. Let's have us another contest. A free SAMS book to the best 10 uses for the M50734. The overall winner gets an all expense paid tinaja quest for two (FOB Thatcher, Arizona), plus some possible cash type money if their entry is good enough to become a *Modern Electronics* feature or construction article.

What is a UART

There are two different ways of sending data between two points. With parallel data communications, all bits in a data

word are simultaneously sent using as many lines as there are bits. Parallel data communication is very fast but need lots of wires. On the other hand, serial data communication needs only a single wire to get from point A to point B. All bits are sent down the line one at a time in a specific order. Serial data communication is much slower than parallel, but it needs only a single channel.

In general, parallel data communication is used inside or near computers, while serial data links are used between computer systems, particularly over long distances. Consider the absurdity of needing eight separate telephones at both ends to send 8-bit data words.

There are lots of times when you want to convert from parallel data to serial or vice versa. For instance, a lap or handicapped keyboard would best have its data sent to a computer in serial form. Some computers, such as the Apple IIc, output data *only* in serial form. You might like to convert to parallel outside the computer to drive a parallel dot-matrix printer or a power controller full of relays or solid-state power switches.

Some electronic circuits do not have a microprocessor in them. Except for the simplest of computers, the main microprocessor in a microcomputer cannot be expected to sit around all day to generate slow serial code or wait until new serial input data arrives. The micro almost always has better things to do. Instead, there are many special ICs that convert data from serial to parallel and back again as needed. They are cheap and easy to get.

These special circuits are called UARTs, short for Universal Asynchronous Receiver Transmitters. The "asynchronous"

in the name means that any amount of time can go by between successive transmissions or receptions.

There are two basic types of UARTs. A hardware UART is used when there is no microcomputer involved at its end of the communication channel. Two examples of hardware UARTs are the Intersil IM6402 and IM6403. With hardware UARTs, the data formats are set by physical jumpers, and the input and output data appears on individual lines.

A Peripheral style UART is intended for use with a controlling microprocessor. The Rockwell 6551 is a typical example. With a peripheral UART, the data format and sometimes the data rate is settable by software. Input and output parallel data is usually routed directly to the data bus on the controlling micro.

Figure 2 shows the usual format of a serial asynchronous code. This was originally called the Teletype code. Very often this code is sent from system to system by using RS-232C standard levels and pin-outs. Note that a code and a standard are two totally different things.

You always start with a start bit that tells the receiving UART that a new character is to arrive. Remember that with asynchronous communication, a random amount of time can go by between individual transmissions. The actual code bits then follow in sequential order, starting with the LSB, or least-significant bit. After the code bits a minimum of one or two stop bits is sent, followed by as many more stop bits as you need to wait until the next transmission.

The speed of transmission is set by the baud rate. The baud rate is defined as how fast the bits come out of the pipe. Popular

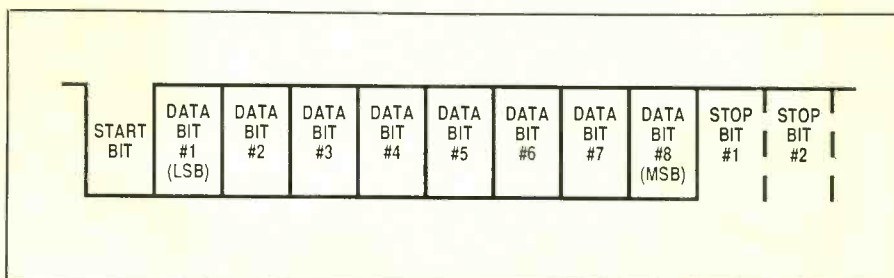

Fig. 2. The standard 8-bit asynchronous serial code.

HARDWARE HACKER . . .

baud rates include 300 baud for modems and 9600 baud for printers. You can roughly relate baud rate to cps (characters per second) by dividing by 10. Thus, a 300-baud modem link maxes out at 30 cps.

Most UART circuits need input reference frequencies that are far higher than the communication baud rate. Among other reasons, this lets the receiver circuit sample only the very center of a received data bit for minimum noise. Often, but not always, the system baud rate reference will be 16 times the actual transmission and reception baud rate.

While eight data bits are usually the norm, five or seven are sometimes used. It is also possible to use an optional error-checking parity bit, although this is not done too much in local microcomputer use. The parity bit forces all of the ones in a word to an even number; if an odd number was received there was an error. Odd parity can also be selected.

It is extremely important that the baud rate, number of data words, number of stop bits, and parity (if any) agree between sending and receiving ends. Since both baud rates must agree to better than one-percent accuracy, crystal control is normally used at both ends.

Show me some UART circuits.

The Intersil IM6402 is a good choice for a modern hardware UART. This one is available from Digi-Key \$6.90, (part no. NT5000-ND) among other dealers. The IM6402 is pin-compatible with earlier UARTs, but needs only a single +5-volt power supply.

As with earlier hardware UARTs, the IM6402 needs an external $16 \times$ baud rate that is input to the transmitter on pin 40 and input to the receiver on pin 17.

The number of data, parity, and stop bits is programmed by jumpering pins 34 through 39 to ground or +5 volts. Making all of these +5 volts gives you eight data bits, no parity, and two stop bits. Consult the data sheet for any of the other combinations if you need them.

Naturally, you should *never* use *any* integrated circuit without the data sheet and any available ap notes on hand and these

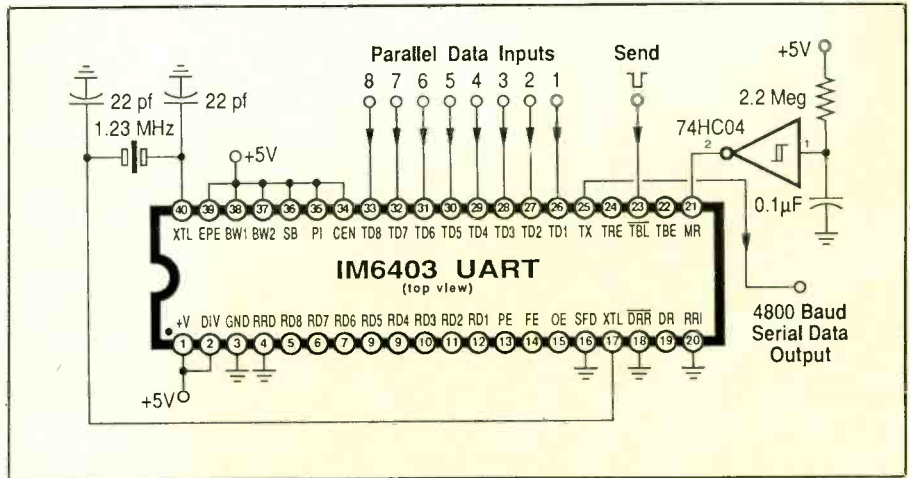

Fig. 3. Typical UART transmitter could be used for a laptop keyboard.

should be thoroughly understood before you do use a given UART.

In general, the "top half" of a hardware UART is used to transmit, and the "bottom half" to receive.

The IM6403 is a variation on the IM6402 that has some interesting advantages. Instead of a pair of $16 \times$ baud rate inputs, you can hang a crystal directly on the chip and generate your own internal baud rate. Unfortunately, many popular

baud rates need higher-frequency crystals that require higher supply voltages, preferably +9 or +10 volts, or the baud rate generator will not oscillate reliably.

Figure 2 shows a UART transmitter that is set to 4800 baud, uses a cheap crystal, and runs off a +5-volt supply. A transmitter accepts parallel data in and outputs serial data. Pins 34 through 39 are shown programmed for eight data bits, no parity, and two stop bits. The inverter on the right

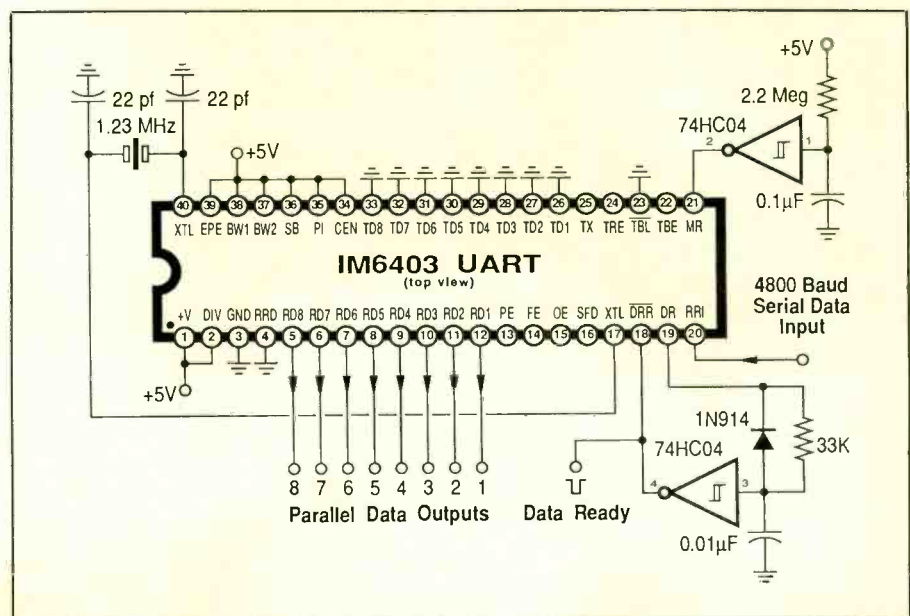

Fig. 4. A UART receiver used to drive a parallel dot-matrix printer.

is one way to do a power-on reset. Any other scheme that briefly brings pin 21 high after power-up will work as well.

One possible use for this circuit is a lap or handicapped keyboard.

Figure 4 shows a UART receiver that accepts serial input data and outputs parallel words. One obvious use would be for a dot-matrix printer adapter for the Apple IIc personal computer.

That bottom inverter requires some careful explanation. In most fancy UART systems, you need full handshaking to make sure that each received character gets used once and only once. To do this, the DR or data ready pin goes high when data is received. When the rest of whatever the UART is driving accepts that character, it resets the UART by bringing the DRR or DataReady Reset line low.

For some simple UART uses, you instead want to just say "here is the data"

and immediately get ready for more data. The bottom inverter does this, outputting a brief negative pulse every time a new character is ready to be received.

Thus, you use this inverter when you do not want or need handshaking. Note that the UART will hang after one character if you do not pull the IC's pin 18 low.

How are figures for this column drawn?

All four figures in this month's Hardware Hacker (and all those that have appeared in this column during the past few months) were "drawn" on an Apple IIc using the stock and popular ProDOS Applewriter word processor. The figure drawing process is sped up and helped along by some utility routines I have put together on my own. These figure textfiles are written in a special yet easy-to-use *Postscript* lan-

guage. The Postscript text files are printed on a Laserwriter printer. The images are then photographically reduced to their final page size.

Note that the quality of these images is vastly better than anything that's currently available from any screen-oriented graphics routine on any microcomputer. This happens because an exact text description is far and away the most powerful, most flexible, and most exact way of wringing the ultimate performance out of the Laserwriter.

With the right utilities, exact text descriptions of electronic figures can actually be done faster and much more compactly than by using screen graphics programs.

For instance, Fig. 4 took about 12 minutes to "draw." The final Postscript file ended up pretty much the same size and with just about the same complexity as an ordinary business letter.

MICRO
MART

508 Central Ave.
Westfield, N.J. 07090
(201) 654-8008

<p>15 Pin Header & Mating Socket, Vert MT/PC</p> <p>156" Centers 5/1.00</p> <p>Combo Green LED's 15/\$1, 100/\$6.00</p> <p>3.300F 35V Axial .1" x .1" N/C 2.95</p> <p>Coils For Radio Elec's Feb. 84 TV Project, Toko #S T-1, T-2, L-1 (12uH) & L-2 (.071uH) Complete Set Of All 4 Coils 8.50</p> <p>MC 330-Prime (Moto) 2/1.00</p> <p>BFQ-85 Transistor 1.50</p> <p>Disc Caps .001uf 20/1.00</p> <p>74123-Prime (Nat) 3/1.00</p> <p>470uf 35V (Radial) 3/1.00</p> <p>470uf 16V (Axial) 4/1.00</p> <p>2N3904 10/1.00</p> <p>2N3906 10/1.00</p> <p>1N914 40/1.00</p> <p>1N4148 40/1.00</p> <p>1N5231B (5.1V Zener Diode) 5/1.00</p> <p>Voltage Regulators (Prime TO-220) 7/805</p> <p>7812, 7824, 7905, 7912-Mix or Match 3/1.00</p> <p>Mica Insulators For TO-220 Pkg. 20/1.00</p> <p>Voltage Reg's (Unmarked, 60% Prime) May include Positive/Neg & Adjust 15/1.00</p> <p>78L08 Voltage Reg (DM106, TO-92) 20/1.00</p> <p>PN2222A 20/1.00</p> <p>2N3055 50</p> <p>Logic Probe (Pencil Type) 18.95</p> <p>Logic Pulsar (Pencll Type) 18.95</p> <p>Zeners (U-Sort), 1N4735A&1N4749A, 30/\$1</p> <p>Relay-SPST 12V Coil, Normally Closed Contacts Open When Energized 95</p> <p>Edgecard Conn 15/30 pin, 156" Ctr's 6/32</p> <p>Screw-In Stand Off Terminal 20/\$1</p> <p>LM309K (MC7805CK) Regulator 1.00</p> <p>15 Cent (1.15) Per IC 74LSXX</p> <p>74LS02 74LS32 74LS158</p> <p>74LS08 74LS74 74LS174</p> <p>74LS10 74LS86 74LS257</p> <p>74LS20 74LS153 74LS273</p> <p>20 Cent (1.20) Per IC CMOS</p> <p>4001B, 4011B, 4050B, 4051B</p> <p>MC838 (DTL) 10/1.00</p> <p>.01uf 100V Mylar Cap (AX) 20/\$1</p> <p>2716 Eprom 1.45</p> <p>2732 Eprom 1.95</p> <p>2764 Eprom 2.45</p> <p>27128 EPROM 4.95</p> <p>256K Dram 150ns Prime Hitachi (Ideal For Mac Upgrades & Expansion Projects) 4.95</p> <p>8243 (I/O Expander IC) W/Specs 2.95</p> <p>UDN 6118 (Display Driver IC) W/Specs 85</p> <p>UDN 6128 95</p> <p>UCN 4116B-Osc/Freq Div Clock IC-Specs-5/1</p> <p>2N3643 (NPN TO-92) Plastic 10/\$1</p> <p>LM339 45</p> <p>LM380 (ULN2280) 45</p> <p>555 Timers (TI) 4/1.00</p> <p>NE555 (Dual Timer-Moto) 50</p> <p>741 Op Amp 4/1.00</p> <p>LM1310 (Unmarked, Tested Prime) 50</p>	<p>LM1889 95</p> <p>LM3900 45</p> <p>AM/FM Radio IC (#2204 W/Specs-Hobby) 15/1.00</p> <p>IC Sockets</p> <p>8 PIN .07 14 PIN .13 16 PIN .15</p> <p>18 PIN .17 20 PIN .19 22 PIN .21</p> <p>24 PIN .22 28 PIN .24 40 PIN .39</p> <p>7 Segment Display (.3" Common Cath) 15</p> <p>7 Segment Display (.6" Common Ann) 65</p> <p>Trn Slate LED's 3/1.00</p> <p>Jumbo Red LED's-Diffused Lens, Prime (TI) All 100% Prime-15/\$1, 100/\$6, 1,000/\$57.50</p> <p>LED Mounting Clips & Rings 15/1.00</p> <p>TuF-200V Mylar Film (AX) 15/\$1</p> <p>UDN1180 Segment Driver IC/Data 65</p> <p>Dip Switch-12 Position 2/1.00</p> <p>Dip Switch-8 Position 4/1.00</p> <p>Keyboard Push Button Tops 30/1.00</p> <p>Audio Cable 30 Feet/1.00</p> <p>22AWG Wire 50 Feet/1.00</p> <p>27AWG Wire 50 Feet/1.00</p> <p>Mini Lubricator (& Lubricant) 1.00</p> <p>Molex Pins (7 Pin/Strip 100/\$2,500/\$4, 1K/\$5 MC1458 (dual 741) 4/\$1.00</p> <p>ULN2274 (dual audio power amp) 75¢</p> <p>Rotary Switch (5 Position, 5A 125V)-3/1.00</p> <p>Giant Alpha Numeric Display 1-1/2" X 2" 7X5 (35 Total) Red LED Matrix/Specs-4.95</p> <p>11 LED Bar Graph Display-2-3/4" Rect LED's (Specify Red, Grn, Amb) Specs 2.69</p> <p>Seven Amp (?) Tapped Transformer-Can Be Wired For (1.5V, 3V, 15V, 18V) Reg Shpg. 8.95</p> <p>Wall Plug Transformer-24V 525mA 1.50</p> <p>6.3V 1.2A Transformer 1.20</p> <p>12V Center Tap Transformer 2.50</p> <p>8AMP 200V BRIDGE, QUICK DISCONNECT (GII)95</p> <p>1N4007 20/1.00</p> <p>1N5069 (200V 1 Amp) 15/1.00</p> <p>1N5060 (400V 1 Amp) 10/1.00</p> <p>Zener Diodes-20V 1W 30/1.00</p> <p>Zener Diodes-13V 1W Glass 30/1.00</p> <p>2560DK Crystal 50</p> <p>3.579545 Color Burst Crystal (HC-18) 50</p> <p>0015uf 100V (152) 1.95</p> <p>6.0 Mhz Crystal 1.95</p> <p>TO-5 Heat Sinks (Berrn) 10/1.00</p> <p>TO-18 Heat Sinks (Berrn) 10/1.00</p> <p>Super Sub-Mini Ceramic Caps (All 100V)</p> <p>0022uf 100V (182) 30/1.00</p> <p>0027uf 100V (272) 30/1.00</p> <p>0033uf 100V (332) 30/1.00</p> <p>0039uf 100V (392) 30/1.00</p> <p>005uf 100V (562) 30/1.00</p> <p>0082uf 100V (822) 30/1.00</p> <p>4.7uf 40V Lytic (Radial) 20/1.00</p> <p>47uf 25V Lytic (Radial) 10/1.00</p> <p>1000uf 185V Twist Lock 1.00</p> <p>3200uf 50V (Ideal For Power Supplies)-1.00</p> <p>5600uf 25V (Comp Grade 3-5/8" X 1)-3/1.00</p> <p>1uf 50V Monolithics 10/1.00</p> <p>.01uf 50V Monolithics 20/1.00</p>	<p>Chip Caps-Set of 4, 2 Each 2.7 & 3.3pf-1.00</p> <p>.33uf 100V Dip Mylar 10/1.00</p> <p>1N4004 Diodes 30/\$1.00</p> <p>Pots-1 Meg, Linear Taper 5/1.00</p> <p>Motion Detector Bds (Inc IC-\$2) 7/10.00</p> <p>Mot Det (IC Only-UL N2232A) 3/\$2-20/10.00</p> <p>Project Box/Lid For Detector 1.95</p> <p>Miniature Speaker For Detector 65</p> <p>Extensive Construction Article For Det. \$1</p> <p>TV Knobs 15/1.00</p> <p>Ammeter (0-15 A.C. Amperes) 4.95</p> <p>Volt/OHM Meter MVMNT (0-1K OHM 0-300V) 2.95</p> <p>6V Miniature Gear Motor 50</p> <p>RF Chokes-1.8uh, 8.2uh, 12uh, 22uh-10/1.00</p> <p>40 Pin Insulation Displacement Connector 40</p> <p>50 Pin Insulation Displacement Connector 50</p> <p>14 Pin Dip Header Plug/Mate (3M) 3/1.00</p> <p>Mixed Connector Ass't 10/1.00</p> <p>1.5AMP 50V Bridge (GI, TO-5 Pkg) 50</p> <p>25AMP 200V Bridge (Conec Lug Term) 1.50</p> <p>Zenith TV Replacement IC Special \$1 Each</p> <p>221-42, 221-43, 221-45, 221-48, 221-69, 221-79, 221-87, 221-96, 221-104, 221-105, 221-106, 221-140</p> <p>25D900 (Horiz Output W/Damper Diode)-2.95</p> <p>25C1172B (Toshiba-Horiz Output Trans)-1.95</p> <p>Winograd 4 Bay Bowtie UHF Antenna-19.50</p> <p>IC Storage (Bug Box Holds) 30 IC's-2.25</p> <p>Preclon (Multi-Turn) Trim Pots (Copa) 100 OHM, 500 OHM, 1K, 2K, 5K, 10K, 20K, 50K, 100K, 200K, 500K, 1M-85 Each-3/\$2</p> <p>Pher PT-10V Hor Mt (Single Turn) Trimmers 100 OHM, 1K, 5K, 10K, 25K, 50K, 100K, 200K, 500K, 1M 25 EA/CH</p> <p>Mixed Coll Ass't 10/1.00</p> <p>Buzzers 3/1.00</p> <p>Chip Resistor (6.8K) 20/1.00</p> <p>Chip Resistor (470K) 20/1.00</p> <p>Chip Cap (330pf) 20/1.00</p> <p>35 Pin Rt Angle Header conn. 50¢</p> <p>MFR 901 (Hobby Grade-60% Good) 10/1.00</p> <p>IC Ass't (Hobby Grade, Some Marked)-30/\$1</p> <p>74SC374-D Type Flip-Flop, Non/Inv</p> <p>74SC533-Transparent Latch-Inverted</p> <p>74SC534-D Type Flip-Flop, Inverted</p> <p>74SC540-Octal Buffer/Line Driver-Inv</p> <p>74SC541-Octal Buffer/Line Driver-N/I</p> <p>74SC563-Transparent Latch, Inverted</p> <p>74SC564-D Type Flip-Flop, Inverted</p> <p>74SC573-Transparent Latch, Non/Inv</p> <p>74SC574-D Type Flip-Flop, Non/Inv</p> <p>Data Book For All Above #s 2.50</p> <p>Cypher IV Micro-Controller Kit- \$129.50</p> <ul style="list-style-type: none"> 4 MHz, 8-Bit Microprocessor (NAT 1NS8073) Control Basic Interpreter On-Chip Auto-Start Operation At Power-On Fast 16-Bit Multiply And Divide RS-232, Supports CRT & Serial Link 24 Bi-Directional I/O Lines (8255A) RAM Memory-2K Expandable To 16K Eprom Memory Expandable To 16K Built In Eprom Programmer Parrr (Centronix) Printer Interface Optional Real-Time Clock W/Backup <p>Pay TV Hardware Installation Kit Blow Out As Low As \$2.95 + \$3.50 Shipping Per Unit</p> <p>All Kits Contain 5 F Connectors, 300 to 75 OHM Patch Cord, 300 OHM Terminal Block, 2 Ft 75 OHM Patch Cord, 2 F1300 OHM Twin Lead, Nylon Cable Ties, And UHF Antenna</p> <p>Model #4124-\$2.95 Includes All Of The Above Plus 25 Feet Coaxial Cable And Mounting Hardware For Indoor Wall/Ceiling Installation</p> <p>Model #4880-\$2.95 Includes All Of The Above Plus 25 Feet Coaxial Cable And Attractive Expandable Pole-U-Bolt For Easy Indoor Installation</p> <p>Model #4845-\$3.95 Includes All Of The Above Plus 65 Feet Coaxial Cable And All Necessary U-Bolt Hardware</p> <p>MODEL 705 Digital Multimeter</p> <p>DC Voltage 100uV to 1000V</p> <p>AC Voltage 100uV to 750V</p> <p>DC Current 0.1uA to 10A</p> <p>AC Current 0.1A to 10A</p> <p>Hi-Z Resistance 0.1Ω to 20MΩ</p> <p>Capacitance 1pf to 200F</p> <p>Diode Test forward voltage testing</p> <p>Hr test transistor testing</p> <p>UHF-TV PREAMP</p> <p>(As featured in Radio Electronics March/ May articles, 1982)</p> <p>This inexpensive antenna mounted pre-amp can add more than 25 dB of gain to your system. Lots of satisfied customers and repeat orders for this high quality kit, which includes all component parts, PC BD, Case, Power Supply and Balun \$3.50 Assembled Version \$57.50</p> <p>Terms: MICRO-MART accepts Visa, MC and telephone COD's. Minimum order \$10.00. Shipping—U.S. orders: \$2.00. Canada and other countries \$3.50 (includes ins.). Shipping rate adjusted where applicable. NJ residents add 6% sales tax.</p> <p>MICRO-MART • 508 CENTRAL AVE., WESTFIELD, NJ 07090 • (201) 654-8008</p>
--	--	---

Say You Saw It In Modern Electronics

CIRCLE 33 ON FREE INFORMATION CARD

April 1986 / MODERN ELECTRONICS / 81

HARDWARE HACKER...

Let's quickly sum up some of the key secrets of my new schematic drawing utilities:

First is a gray rubber grid that lets you stretch or squash the drawing to the size you need. Normally, one unit of the grid is defined as the space between adjacent pins on an IC package. You can turn the grid on and off as needed. Unlike screen graphics grids, you can easily use fractional grid values. No matter how fine the grid or how nervous the programmer, horizontal and vertical lines always stay that way.

Second is the use of *opaque symbols*. A symbol is something like a resistor, an IC or an inverter. Whenever these symbols are put down, they erase and then overwrite whatever happens to be under them. Thus, you could put down one *continuous* wire first, and then drop a resistor on top of it. This is far faster and easier than worrying about exactly where each connection to

NAMES AND NUMBERS		
Adobe Postscript 1870 Embarcadero S120 Palo Alto, Ca 94303 (415) 852-0271	Digi-Key 701 Brooks Ave. South Thief River Falls, MN 56701 (800) 344-4539	OKI Semiconductor 650 North Mary Avenue Sunnyvale, CA 94086 (408) 720-1900
Apple Computer 20525 Mariani Avenue Cupertino, CA 95014 (408) 966-1010	Mitsubishi 1050 East Arques Avenue Sunnyvale, CA 94086 (408) 730-5900	Rockwell International 3310 Miraloma Avenue Anaheim, CA 98203 (800) 854-8099
Intersil 10710 N. Tantau Avenue Cupertino, CA 95014 (408) 996-5000	NEC Electronics 401 Ellis Street Mountain View, CA 94039 (800) 632-3531	SAMS 4300 West 62nd Street Indianapolis, IN 46206 (800) 428-SAMS

each part of each symbol has to go. Symbols can later be slid along a wire for best final appearance.

Third is the use of action points. Rather than define the position of a symbol from its corners, you define it from a logical connection point instead. The action point of a resistor would be its center. The action point of an IC pictorial is the center of pin one, and so on.

Fourth is the use of an automated DIP pictorial generator. To draw a complex 40-pin integrated circuit, you use a special routine. All you have to tell this routine are the number of pins, the name of the chip, and two strings of callouts as needed for the top and bottom pin rows. Thus, an entire DIP pictorial is drawn with a few dozen keystrokes! Complement bars are easily added when and as needed with a companion routine.

Fifth is the use of slide-under wiring. Since the symbols are all opaque, they will position themselves on top of any wires and will completely erase any wire under them. By putting the wire descriptions early in the textfile and the symbols late in the textfile, all of the wires will magically stop at the exact edge of each symbol. Usually, you put your symbols down first, and then slide the wires under them. This mind-boggling trick is done simply by entering wire descriptions above the symbol callouts in your textfile.

Sixth is the use of predefined symbols. To show a resistance omega, you just type the word "ohms." To show a capacitance

mu, you just type the word "micro," and so on. Things like arrowheads, clock pulses, and connection dots are similarly handled. You do not have to define these in the textfile for a particular schematic; they are already predefined in the pre-loaded schematic utility routines.

Seventh, and finally, is the use of self-breaking wires. Note the white space in Figs. 3 and 4 every time a horizontal wire ducks under a vertical one. This gets handled automatically by drawing a fat white vertical wire and then redrawing a thin black vertical wire on top of the white one. Special adjustments are made to keep from erasing portions of the wire endpoints. You can pick no breaks, vertical breaks, or horizontal breaks per your drawing style.

These same ideas will work very well for quick and simple printed circuit layouts. More on this some other time.

I'd be most happy to send you some free listings of these utility routines, along with a few mind-boggling demos.

Just call or write.

ME

SIBEX MODEL S-1

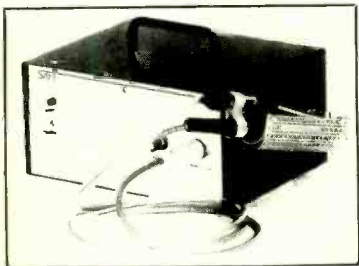

"The Low Priced Desoldering Tool with the High Priced Features"

- Built in vacuum pump for efficient desoldering
- Easily cleaned in use
- Designed for PC repair

PRICED AT \$189.95

SIBEX Inc.

3320 U.S. 19 N. • Suite 410
Clearwater, Florida 33519
(813) 786-3001

CIRCLE 46 ON FREE INFORMATION CARD

First Impressions: Ashton-Tate's Framework II Integrated Software package; Tecmar's MegaFunction Memory-Expansion, RAM-Disk and I/O Board

By Eric Grevstad

Before tackling this month's other topics—an expansion board with something extra and an editorial on DOS enhancements—I must face conflict-of-interest charges. I'm going to give a rave review to a program from Ashton-Tate, whose publishing arm produced Jim Heid's and my beginner's book about the Tandy 1000.

Having confessed the connection, I'm not sure how to prove my objectivity except to say that the company's dBase III and MultiMate are not my favorite database and word processor. Also, I'm mad that Ashton-Tate wouldn't give advance information so the software section of our book, not mentioning this new product, is outdated. The product is Framework II, and it's the single best computer program I've seen.

A Splendid Success

Other programs still haven't matched Framework's concept of handling three-dimensional frames, containing and combining multiple files, instead of two-dimensional windows onto separate files. And its elegantly easy commands—pull-down menus, ample on-line help, and Select, Move, and Copy functions that work for everything from word processing text to spreadsheet cells and disk files—almost belie its tremendous power.

Still, by its 1984 debut, the market was already losing the notion of giant integrated packages as the only software anyone would ever need. A buyer taking a casual glance at Framework might have thought it built mainly around two less popular functions, its outline processor and FRED, a sort of half-spreadsheet, half-dBase programming language, while its rival Symphony carried a mighty Lotus spreadsheet (though its other applications were and are inferior).

Framework II represents a new marketing approach as well as a complete technical upgrade. Instead of "Colossal product that overflows 512K machines," it's modestly billed as "word processing,

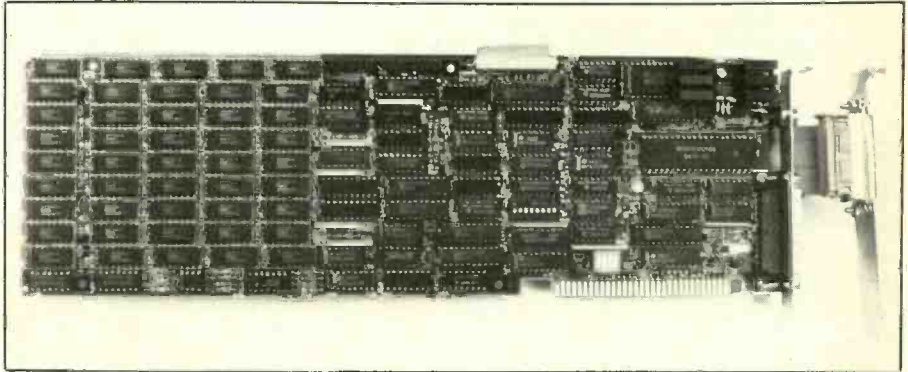

The Tecmar MegaFunction board combines memory expansion, RAM disk and input/output ports on a board that takes up one slot.

spreadsheets, and more." Snazzy packaging and a fine series of manuals lessen the intimidation of the four-volume, eight-disk bundle. FRED's moved into the background and improved applications have taken center stage.

The word processor still has much of the cut-and-paste ease and fancy on-screen formatting of Microsoft Word, but now boasts mail merge, visible page breaks (hear that, Word?) and a fast, flexible spelling checker.

The spreadsheet runs faster and allows bigger worksheets, as do new versions of 1-2-3 and Multiplan, by not wasting memory on empty cells. It creates smaller files, too—a 7,500-byte Framework 1.0 spreadsheet translated to a 3,000-byte Framework II file. (I can now endorse the program for 384K systems as well as larger ones, but still urge a hard disk over floppies.) Spreadsheet or data base graphs, drawn with three keystrokes, come in seven flavors, from bar and pie to high-low-close charts, and both text and numeric applications support custom libraries of macros and abbreviations.

Framework II's spreadsheet-style data base is more modest, lacking relational abilities and making you sort one field at a time, but I found it faster and easier to use than PFS:File. Ashton-Tate supplies a menu option for users who want to add dBase III to the Framework desktop; you can add other programs if you write a short FRED routine, or simply run them from a DOS access gateway without leav-

ing Framework. One program that was clumsily tacked on before, the communications package Mite, is a finely enhanced, integrated, menu-driven part of Framework II.

If that's not enough, Framework II handles more imports and exports than Hong Kong harbor. Besides its own and ASCII files, the program reads and writes dBase, MultiMate, IBM DCA, WordStar, and 1-2-3 (version 1A) formats; FRED will let you add three other files. There are minor quirks with this software—a Lotus file doubles in size from .WKS to .FW2 style, despite losing its macros, graph, or data base info, and I had to edit the file that imports WordStar files, changing its default header ("here is left header") and page length (five lines).

But that, and a copy-protection scheme that can prove fatal if you try the DOS hard disk Backup and Restore commands, are my only complaints. (At least you can start work without a key disk, change your hardware setup any time, and uninstall the program to change computers.) Otherwise, Framework II is spectacular: a smooth integrated package as good as six stand-alone programs, worth its \$695 price but under \$400 from mail-order dealers. It could genuinely be the only software you'll ever need.

The Phantom Disk

Let kiddies swap floppies and AT owners argue who's got bigger hard disks; real

PC PAPERS...

Apps Disk Create Edit Locate Frames Words Numbers Graph Print 12:39 pm

[2Q Graph]

(Thousands)

Month	North	South
April	~50	~30
May	~60	~40

2nd Quarter

	A	B	C	
3 North	\$43,018.60	\$28,340.50	\$42	
4 South	\$35,564.21	\$54,089.65	\$27	
5 East	\$22,875.33	\$46,873.11	\$87	
6 West	\$16,876.44	\$54,300.87	\$15	

[Letter to the Editor]

must congratulate you on supplying a reliable source of project ideas and product information. However, while I enjoy nearly all of Modern Electronics, there is a glaring exception.

The column entitled "PC Papers" is the worst mix of chatty writing and ignorant opinions I have ever read. The author seems

[Letter to the Editor]

[2Q Graph]

[2nd Quarter] Doc: 2/3

Framework II's desktop, showing graphics, spreadsheet and word-processing frames. My screen printout program missed on-screen underlining of "Modern Electronics."

riverboat gamblers use RAM disks. The fastest Winchester can't match an electronic drive's speed; the craziest lunatic can't deny the danger of storing programs where a neighbor's turning on a hair dryer might annihilate them.

But if you're like me, once you've tried a RAM disk you can't resist loading programs in seconds. Even so, there's the nuisance of having to refill the thing each

morning, as well as its subtracting workspace from your system. To solve those problems, check out Tecmar's MegaFunction board—a card that combines the usual clock/calendar, serial, and parallel ports with 1.25 MB of memory, plugged into a floor-mounted adapter that keeps your RAM disk intact, even if the computer's off, as long as the wall socket stays live.

Outline and database frames share screen with a Framework II pull-down menu, reached with the Ins and arrow keys or by shorthand commands (Ctrl-ER here).

Apps Disk Create Edit Locate Frames Words Numbers Graph Print 1:19 pm

[Notes for Speech]

- ▶ 1 Anecdote: intro
 - 1.1 thanks for welcome
 - ▶ 1.2 reminds me of stor
 - 1.2.1 tell story
- ▶ 2 Look back at 3rd qtr
 - ▶ 2.1 Sales up
 - 2.1.1 Eastern Div.
 - 2.2 Kickback scandal c
- ▶ 3 Looking ahead: 4th qtr

[Clientele]

Last Name	Fi	Address
Acworth	Su	400 Park Ave.
Atkinson	Diane C.	484 Fernwood P
Blofeld	Ernst S.	136b Blvd Haus
Marshall	Frank	32 Sixth Ave.,

[Clientele]

[Notes fo]

Notes for Speech Doc: 2/2

Remove selected rows/records from a spreadsheet/database

Besides DIP switches to disable or assign DOS numbers to its RS-232C and printer ports (the latter, if used, covers a second expansion slot), the \$895 board includes switches that specify either a 1268K RAM disk or a smaller disk and 384K of system memory. Installed in a 256K PC, XT, or compatible (it won't work with AT or early PC1 motherboards), MegaFunction yields a 640K system plus a 760K RAM drive, which can turn a PC into a mini-XT by booting DOS with no floppy required. RAM maniacs can add a \$795 daughterboard for another two megabytes.

The board worked well in my Tandy 1200 HD, accepting unprotected software, DOS subdirectories, and Norton Utilities checks just like a regular drive—the difference, of course, being its fast DMA (direct memory access) response time. Its 5-volt, phone-sized ac adapter grew slightly warm but survived numerous accidental kicks beneath my desk, retaining the RAM drive and directories while the Tandy slept.

On the other hand, it seemed hostile to copy-protected software. PFS:File's installation program said "Cannot access target drive," and the Tecmar's presence crashed Framework II, which recognized and read conventional (part of main memory) RAM disks. According to the tech support engineer I called MegaFunction organizes its tracks and sectors differently than a physical drive. Too, the MegaFunction board might give a false sense of security, lulling users to skip backups—though it's vulnerable to power failures 24 hours a day, not the eight hours or less a software RAM disk is in actual use. (A \$295 backup battery supports the board for one hour.)

All told, the MegaFunction might be fun if you don't already have an upgrade board, and particularly if you lack a hard disk and want to load DOS faster. If you've already got a card and don't need another clock or serial port, you can get above-640K RAM disks plus workspace for the newest programs with an expanded memory unit like Intel's Above Board. It'll need reloading every morn-

ing, but what's an AUTOEXEC.BAT file for?

Heaven Can Wait

Now I'll take off my reviewer's hat; I considered writing an April Fool item for this issue, but decided to write a sage opinion or editorial instead (*How can you tell the difference?—Ed.*) Specifically, I want to clarify last month's remark that a DOS menu like Bourbaki's Idir might eliminate the need for graphics interfaces like Microsoft Windows. "Even if Windows weren't an upcoming standard," I hear you mutter, "how can you ignore its support of multi-tasking? Shells like Idir can't run programs concurrently.

First, let me go on record against Microsoft by stressing the key word in my phrase "no need for graphics interfaces." I think pull-down or pop-up menus like those of Framework II or Alpha Software's Keyworks are a splendid way to run software, with or without a mouse. But such programs get along fine without graphic icons. Graphics take more memory than ASCII characters, and many video cards can't show them.

As for multi-tasking, I'll change my casual dismissal to a partial one. When you think about it, background processing is a boon for printing and communications, and possibly for huge data base sorting jobs.

Otherwise, what people need aren't concurrent programs but co-resident ones—applications waiting, if not running, in the background, for use without having to quit one program and load another. This is why I'm a fan of simple switcher utilities like Awesome Technology's Multiple Choice (reviewed December 1985), which allow DOS access or cut-and-paste date transfer in much less memory than TopView or Windows.

For true multi-tasking, you'll need two things: a more powerful processor than the 8088, which leaves PC and XT owners out, and a version of DOS that supports multi-tasking and memory above 640K, which the AT still lacks at this writing. Without one of the expanded memory

cards that switch banks of RAM past a 64K access frame, even a three-megabyte AT is only a 640K machine.

The obstacles may fall to DOS 4.0 by the time you read this, or possibly not for a year or more. Meanwhile, 8088 machines are becoming cheap appliances like VCRs or toaster ovens, and you can improve them cheaply with switchers, speedup boards (see February 1986), or expanded memory, supported by a growing number of applications. Some of the latter (Framework II, Windows) allow the more homely trick of virtual memory, swapping your least recently used material to a hard disk.

Someday soon we'll all have 20 megabytes of RAM and everything will be memory-resident (witness the promise of Borland's Turbo Lightning data retrieval system, now primarily a spelling

checker). But right now you can get 90 percent of the power that 90 percent of users will ever need. If the PC didn't have all the keen software, I'd take my conservative viewpoint even further and endorse the Apple II.

Why, look what just came for next month's column: Windows. Stay tuned and see if I eat my words. **ME**

Names and Addresses

Ashton-Tate
20101 Hamilton Ave.
Torrance, CA 90502-1319
213-329-8000

Tecmar Inc.
6225 Cochran Rd.
Solon, OH 44139-3377
216-349-0600

ATTACH LABEL HERE

PLEASE PRINT

ZIP

NEW ADDRESS HERE

STATE

DATE

NAME

ADDRESS

CITY

MODERN ELECTRONICS

MODERN ELECTRONICS

MODERN ELECTRONICS

76 N. Broadway,

Hicksville, NY 11801

SUBSCRIBER SERVICE
CHANGE OF ADDRESS

Planning to move? Please let us know six weeks in advance so you won't miss a single issue of MODERN ELECTRONICS

Attach old label and print new address in space provided. Also include your mailing label whenever you write concerning your subscription to insure prompt service on your inquiry

MODERN ELECTRONICS
76 N. Broadway,
Hicksville, NY 11801

Now available to everyone!

Computel Publishing Society
a unit of the Computel System presents...

The one you've all been waiting for



Computel
PUBLISHED MONTHLY

ONE YEAR SUBSCRIPTION: \$14.00
CANADIAN: \$18.00 FOREIGN: \$24.00
(SAMPLE COPY: \$1.00) (BACK ISSUE: \$2.00)

- ◆ The membership Print Certificate—can't be bought, looks like a real membership, created by the Computel staff to signify membership in the Computel System!
- ◆ Hundreds of WHO'S HOT and below-wholesale priced electronic gift items available for your own personal use or for use with the Computel Merchandise Distribution Plan—marketing techniques for your own business!
- ◆ Group discounts when buying computer systems, supplies, and components with the other members of the Society, from huge discounts and factory shutdowns that we are constantly seeking as they occur!
- ◆ Discounted prices on computer hardware and software purchased through the Society at worldwide outlets!
- ◆ A comparison of the computer systems and equipment on the market BEFORE you make an investment, through Computel's advisory panel of members whose dedication in your locality will assist you on where to buy and where to get help!
- ◆ A multinational magazine bulletin board for students, visitors, management personnel, Computer Hackers, Phone Phreaks and anyone interested—spanning the world of Computers, Electronics and Communications, getting the hobby and the profession in a spectacular display of creativity you won't want to miss!
- ◆ FREE advertising in Computel for members who wish to trade or sell their equipment, leave messages, or just want to find out what's going on with other members—we will publish almost anything you submit to us!

INFORMATION NEVER BEFORE PUBLISHED FOR THE PUBLIC!

Learn the secrets of computing!

COMPUTEL—the complete SOURCE for everyone. You can now do the things you've only heard about, right in the privacy of your own home. Indispensable reference for phreaks and hackers. Learn how to get all kinds of computer programs FREE. Get the inside story of big business systems—their sparks and flames—and reveal up to date vital occurrences within the computer industry. Computel is a publication designed for everyone who has an intense curiosity about computer systems. Containing a wealth of hard-to-find information that you just won't find elsewhere! Subscribe now, and join the thousands already engaged!

You will be in control of your computer with the only publication of its kind written for the user. Discover the secrets and gain the sensitivity of modern computer command control concepts. Experiment with computer and telephone systems, interface them, learn how they work, what they do... and how to get them to work for you! Everything that you heard about in published in Computel, and you won't be satisfied until you have it! Stop guessing, U.S., Bubble, and Atomic Switching Systems are studied. Computers and telephones are the future! This publication is an absolute must for everyone interested! Join the Computel Society NOW!

CRUNCH!

THE CAPTAIN IS BACK...with an all new program for everyone!

- ◆ Check ◆ Money Order ◆ Postage ◆ Cash
- The History of Computing \$14.95
- The History of the Telephone \$16.95
- The Phone Phreaks' Guide to Computers \$19.95
- Telephone Engineering Course \$24.95
- Computer Repair—Do it Yourself and SAVE! \$24.95

ALL 5 REPORTS PLUS A SUBSCRIPTION TO COMPUTEL: \$69.00.

Computel Publishing Society

6354 Van Nuys Blvd., 161-B / Van Nuys, CA 91401-2696

Don't miss out—Subscribe now!

CIRCLE NO. 9 ON FREE INFORMATION CARD

Top Shortwave Programs

By Glenn Hauser

Each year, *Review of International Broadcasting* conducts a listener survey under the auspices of Dr. Kim Andrew Elliot, who is also Chief of Audience Research at the Voice of America. Part of last year's survey has now been published. It ranks programs by the percentage of respondents who listen to each edition (thus evening the odds between programs that are broadcast daily and weekly, for example). This summary is restricted to the top 20.

First, the number of top 20 programs per station: BBC, 6; Radio Netherlands, 3; Radio Canada International, 2; CBC, 2; Radio Sweden, 2; Radio Australia, 2; WRNO, Swiss Radio International, HCJB, and Radio Moscow, 1 each.

Eight of the top programs are in the DX or media news category; five more involve listener-participation, such as mailbag shows. Clearly, shortwave listeners are very partial to programs produced with their own interests in mind. Of the remaining seven, two are straight news, and the other three are news-in-depth programs. One has to go down to No. 24 for a purely entertainment program, BBC's "Play of the Week," something which requires an hour to a sesquihour of attention, surpassing all kinds of lighter entertainment in the ratings.

Here, then, are the top-twenty shortwave shows among North American listeners:

- (1) 38.0 SWL Digest, R. Canada International
- (2) 29.9 World News (BBC)
- (3) 29.5 World of Radio (WRNO)
- (4) 29.1 Media Network (Radio Netherlands)
- (5) 16.4 Shortwave Merry-Go-Round (Swiss R. International)
- (6) 15.6 Letter from America (BBC)
- (7) 11.6 Happy Station (Radio Netherlands)
- (8) 9.5 Waveguide (BBC)
- (9) 9.2 DX Party Line (HCJB)
- (10) 8.5 Sweden Calling DXers (R. Sweden International)
- (11) 8.0 Sunday Morning (CBC)
- (12) 7.8 Radio Newsreel (BBC)
- (13) 7.2 Letterbox (BBC)
- (14) 7.0 Twenty-Four Hours (BBC)
- (15) 6.3 Moscow Mailbag, (Radio Moscow)
- (16) 6.2 As It Happens (CBC)
- (17) 6.1 Talkback (R. Australia)
- (18) 5.5 Listeners' Corner (Radio Canada International)
- (19) 5.3 News (Radio Australia)
- (20) 5.1 Shortwave Feedback (Radio Netherlands)

Radio Club Historics, Memorabilia, and You. A researcher and radio enthusiast seeks to write biographical sketches of prominent DXers of the past, and radio club histories, primarily the Universal Radio DX Club (URDXC), Newark News Radio Club (NNRC), the early American SWL Club (ASWLC), and the early North American Shortwave Association (NASA). Club bulletins from the early days, radio magazines of the '30s and '40s, old photos of DXers and club officials are difficult to find, as are SWL cards of the '50s and '60s, and pre-1965 *World Radio TV Handbooks*. If you are willing to donate to donate or sell such material for historical preservation, indexing, and eventual publication of histories in the DX press for the mutual benefit of everyone, please respond to: Stephen Bohac, R.D. #4, Box 750-A, Branchville, NJ 07826.

Now, a roundup of radio news, mostly shortwave.

Anguilla. Most people consider 1610 kHz to be mediumwave now. But aside from a few flea-powered travelers' information service outlets around airports, parks and highway construction, the Caribbean Beacon has the channel to itself, just about the only remaining "clear-channel station" in the true sense of the word. John Demmitt in Pennsylvania noted stronger signals than usual one night; it turned out they had raised power to 50 kilowatts. This U.S.-backed gospel station still has a Caribbean flavor in its local announcements; give it a try any time after darkness until 0500 UTC. But in the mornings, The Caribbean Beacon uses 690 kHz instead. While there's a fair amount of domestic interference, Cuba has vacated the channel for reasons of its own (see below). Within a few years, U.S. mediumwave stations will

take over 1610 and other frequencies up to 1700 kHz, so now's the time to go for The Caribbean Beacon.

Brazil. The external service from Brasilia was rumored to be facing a shut-down last year, but it seems to have pulled through. Adam Simms received a letter direct from the station saying the reports was unfounded. Listen at 0200 UTC on 11745 kHz. But there are plenty of changes elsewhere on the Brazilian shortwave bands. In addition to last year's reshuffling of stations on the 49-meter band, a similar realignment has been arranged for the 31-meter band, effective date unknown; so report Antonio R. da Motta and Claudio R. Moraes in Brazil.

Canada. Labour contracts are up for renewal again this year at the CBC. That's foreboding news for those who remember a series of strikes that disrupted Radio Canada International news, programming and transmissions during previous labour disputes several years ago. Meanwhile, Austin Kelley in Chicago reports that Radio Japan has been asking its monitors to check RCI transmissions. Both RCI and Radio Japan could benefit greatly by a relay swap—none too soon for North American listeners who rarely have good reception from Tokyo.

Colombia. A new station is Ecos del Putumayo, in Puerto Asis, a remote jungle town. Henrik Klemetz in Ecuador heard it irregularly on 5353 kHz around 1100 and 2300 UTC, with a strong signal. It's a fair bet this one is unlicensed.

Cuba. A new station ostensibly for tourists in Cuba appeared on 1160 kHz, Radio Taino, "tour radio from Havana." While mostly in Spanish, there are English announcements every half hour, and English news capsules scattered throughout the day. It's probably a 75-kilowatt transmitter, but the Cubans restricted it to daytime hours only (1200-2300 UTC), except during hurricane emergencies and special occasions, when it stayed on until 0500, interfering with U.S. stations, notably KSL in Salt Lake City and WJJD in Chicago. This came less than a month after south Florida's most powerful AM station, WGBS, 710 kHz, merged with WNWS,

790 and sold the 710 facilities to a virulently anti-Castro group, Radio Mambi, WAQI (pronounced "aqui," not "wacky"). Within four days, three or four Cuban stations moved onto or near 710 kHz, formerly free of Cubans, in an obvious attempt to block WAQI reception in Cuba. With 50 kilowatts during the day, a saltwater path, and 50 kilowatts directional toward Cuba at night, WAQI had the capability of covering Cuba far better than radio Marti, 1180, which received far more publicity and no increase in jamming. The Cuban programming, and sometimes jamming on and within 5 kHz of either side of 710 kHz, not only blocks Radio Mambi in Cuba, but also disrupts reception of WOR, beyond the New York metro area.

Curacao. Radio Earth is proceeding with plans to set up its own shortwave transmitter on this island, which has commercially supported the operation from the outset. An application has been filed, a transmitter purchased, and sites investigated, for an airdate of June at the earliest, with the callsign PJQ. Besides carrying "The World," Radio Earth's main program, which is also on WHRI, the new station will broadcast many other features and relay overseas shortwave stations badly in need of improved North American reception.

Ecuador. HCJB has begun broadcasting in Chinese—not for China, but for some 2-million Chinese in the Americas it wants to reach with the Christian gospel, daily at 2200-2230 UTC on 11960—subject to change because radio Canada International was already there. John Norfolk and Kraig W. Krist note that the Saturday edition of "DX Party Line" has returned to its 2130 UTC time slot, on 15270 and 17790, again conflicting with the most popular shortwave program, RCI's "SWL Digest." Fortunately, both programs have additional airtimes. HCJB is undoubtedly the easiest Ecuadorian to pick up; if you'd like more of a challenge try for the unlicensed Radio La Voz de la Juventud, from somewhere in the province of Loja, perhaps Higueroles or Catacocha, towns mentioned in ads. Henrik Klemetz found that it is likely to broadcast Sunday nights only, varying around 6581 kHz.

BIG SAVINGS ON LIMITED SUPPLY OF COMMODORE PLUS/4™ COMPUTERS AND FAMOUS BRAND DISK DRIVES

INCLUDES BUILT-IN SOFTWARE

for word processing,
file management,
spreadsheets
and 128 color graphics!
Ideal for home or business!
Perfect for programmers!

Commodore® designed Plus/4™ for small businesses and programmers... then made it VERY EASY for novices to learn and use. For programmers, this machine has easy-to-use powerful commands and 60K of usable memory. And you can hook up as many as four disk drives.

FOUR highly popular programs are BUILT-INTO the machine. And they quickly interact with each other! Use the FILE MANAGEMENT program for mailing lists, inventories, personal or business files, etc. Write and edit letters, reports, student papers with the WORDPROCESSOR before final printout.

Do the books, budgets, sales forecasts, profit/loss statements, etc., with SPREADSHEET program. Every time you change a number, Plus/4™ immediately recalculates entire spreadsheet. Combine the calculations with WORDPROCESSOR text.

Use GRAPHICS program to draw simple or complex shapes. GRAPHICS works with

FACTORY NEW! FIRST QUALITY!

PLUGS
INTO YOUR
TV FOR A
MONITOR!



SPREADSHEET or WORDPROCESSOR, so you can display calculations in up to 128 colors... or include graphics in your text.

Touch a key to go from one built-in program to another. Additional software is available for a variety of businesses or personal uses. Games available, too!

ADDITIONAL FEATURES: Data base of 99 records. Computer holds 99 lines of text before it must be transferred to disk drive for storage. Excellent terminal for use with modem. Split screen and windowing capabilities. Compatible with all Commodore® hardware except joystick and dataset. NOT compatible with C64 software.

Includes Commodore® warranty.

Mfr. List: \$299.00

\$79

Closeout Price

Item H-1129-5035-001 Ship, handling: \$8.00

DISK DRIVE (Compatible with Plus/4™)

A famous U.S. brand, but we're not permitted to print the name. Factory reconditioned and warranted. Intelligent, high-speed. 2K RAM, 16K ROM. Maximum storage of 170K formatted data; 35 tracks. Uses 5 1/4" floppy diskette, single sided, single density (double density can be used, but not needed). Serial interface. Second serial port for chaining second drive or printer. Data transfer rate of 400 bps. Compatible with C64, VIC 20, SX64, Educator 64, C16 and Plus/4™.

Mfr. List When New: \$269.00

\$149

Closeout Price

Item H-1129-3553-013 Ship, handling: \$8.00

Credit card customers can order by phone, 24 hours a day, 7 days a week.



Toll-Free: 1-800-328-0609



Your check is welcome!
No delays in orders paid by check.

Sales outside continental U.S. are subject to special conditions. Please call or write to inquire.

C.O.M.B.
DIRECT MARKETING CORP.

Authorized Liquidator
14605 28th AVENUE NORTH
MINNEAPOLIS, MN 55441-3397

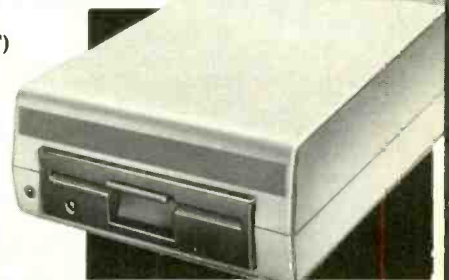

C.O.M.B. Direct Marketing Corp. Item H 1129
14605 28th Ave. N./Minneapolis, MN 55441-3397

Send ___ Commodore® Plus/4™ Computer(s) Item H-1129-5035-001 at \$79 each plus \$8 each for shipping, handling.
Send ___ Disk Drive(s) Item H-1129-3553-013 at \$149 each plus \$8 each for shipping, handling.

(Minnesota residents add 6% sales tax. Allow 3-4 weeks for delivery. Sorry, no C.O.D. orders.)

My check or money order is enclosed. (No delays in processing orders paid by check, thanks to TeleCheck.)

Charge to my MasterCard® VISA®

Acct. No. _____ Exp. / _____

PLEASE PRINT CLEARLY

Name _____

Address _____

City _____

State _____ ZIP _____

Phone (____) _____

Sign Here _____

Jamaica. We've been hearing JBC Radio One on a new frequency of 850 kHz during hours of darkness. Ron Schatz says channel 1 is registered for a relay at Old Harbour, southwest of Kingston.

Nicaragua. This country has become rather paranoid about "intrusion" of foreign broadcasts, something which is actually completely natural and unavoidable in a small country next to others. On an anti-communist TV program in Miami, former Nicaraguan government communications minister Mario Cordero charged that the Sandinistas are setting up to two powerful new transmitters of their own, one about 100 km northwest of Managua, and the other in a remote coastal area lacking roads near Puerto Cabezas on the Caribbean. We assume these will be mediumwave.

Saba. There has been a radio station on

this Netherlands Antille for a year or two, which has escaped official notice, but has been heard by visitors to nearby St. Maarten, such as John Schmid—it's Voice of Saba, on 1410 kHz.

St. Kitts. Another small Caribbean island is well-known among mediumwave DXers, thanks to the powerful Radio Paradise, 835 kHz, another U.S.-backed gospel outlet. But now it's made short waves too, due to a third harmonic on 2475 kHz, heard during the evening hours by Bob Hill in Massachusetts.

San Andres. This Colombian island off Nicaragua amounts to a separate radio country well-known to hams, but not to mediumwave and shortwave DX listeners, since its radio stations are usually mixed in with Colombian mainlanders. Radio Morgan (probably named after the pirate Henry Morgan) has made a sur-

prise appearance on 2522.8 kHz, the second harmonic of 1261.4 (nominal 1260 kHz), during the evening. We found it fascinating listening, with its mixture of Spanish and Caribbean English. Also on the air from the island is Radio San Andres, 910 kHz, seldom heard in the USA; but we picked it up during the daytime on a visit to Costa Rica.

Sweden. After decades as a Tuesday fixture, "Sweden Calling DXers" moved to Wednesday on Radio Sweden International. Complicating the picture was an advanced start to the next UTC day's programming, so that it appears on the 2300 UTC Tuesday, and 1400 UTC Wednesday broadcasts, the latter on 15345. Once a prime source for shortwave DX news, that now is secondary to information about computers, satellites, etc.

U.S.A. KCBI, Dallas, has added "World of Radio" to its schedule, Fridays at 2100 UTC on 11790, and Sundays 1830 on 11905.

WHRI, Noblesville, Indiana, went on the air toward the end of last year. After several frequency changes to avoid interference, this schedule emerged: 1100-1300 on 5995, 1300-1500 on 11850, 1500-1700 on 15105, 1700-1900 on 15355, 1900-2100 on 11865, 2100-2300 on 9770, 2300-0100 on 11775, 0100-0300 on 9745, 0300-0600 on 7400, 0600-0800 on 6100, 0800-1100 on 7355. Part of these are directed northeast, part directed to the southeast. There may have been further changes in March.

Radio Earth quickly moved from KCBI to WHRI, where it could broadcast at its preferred prime time, 10 pm EST (0300 UTC year-round), six nights a week, on 7400 kHz.

KVOH, Simi Valley, California, experienced delays in transmitter delivery, but hoped to start testing by early March. NDXE, Opelika, Alabama, continues a major advertising campaign without any transmitters and continual target date delays; they've been predicting July 4, 1986. Meanwhile, the FCC points out that they do not plan to authorize such an N-prefix callsign for a broadcasting station. This won't necessarily keep the station from going by those letters—the call letters just won't be official.

ME

ME

Power Supplies Discount Prices!

VERSATILE LABORATORY POWER SUPPLY



ELECTRO INDUSTRIES MODEL 3002A

Reg. \$125.00 Sale Price **\$104⁹⁵**

• 0-30 VDC at 0-2A • Fully adjustable current limiting • CV/CC operation • Excellent load and line regulation • Ripple & noise — 500 uV RMS • Built-in short-circuit and overload protection. Options: 10-Turn Voltage & Current Controls, \$25 ea.

EPSCO MODEL D-612T POWER SUPPLY

• 0-8 VDC/0-16 VDC at 10A • Up to 20A intermittent • Dual panel meters • Unregulated

Reg. \$229.50 Sale Price **\$190⁰⁰**

Check, Money Order or C.O.D. (\$2.00 extra). Add \$4.00 for shipping in Continental U.S. Ill. residents add 7% sales tax. Money Back Guarantee.

Salen Enterprises

P.O. Box 915, Morton Grove, IL
60053 Area 312-465-1424

CIRCLE 22 ON FREE INFORMATION CARD

SOFTWARE FOCUS

(from page 74)

and sentences as you might when reading for pure enjoyment. But in the business and educational world of reading, this is not generally necessary. And that's where speed reading comes in.

A key consideration in this training program is learning not to read every word. If you do, you'll limit yourself to a fraction of your reading speed potential. Instead, reading in "idea clusters" is the core of the training presented in *MicroSpeedRead*. The program operated flawlessly, though I wish that one could press "Escape" in the middle of sections should one wish to quit a part and move swiftly to another. But since I'm talking about only seconds of time perhaps wasted, this is really a minor criticism.

MicroSpeedRead is a most useful computer program for anyone who would like to improve his reading productivity. Average reading speed is 250 words per minute, by the way, while 500 wpm is considered to be only "good." Do you measure up well?

Telephones (from page 39)

ments are supplanting the carbon mike, particularly in electronic telephones, so be alert to it.

The final element is the speech network itself. Because the telephone is a current operated device, it's sensitive to all resistive influences—including those in the link itself. The amount of current flowing through your telephone depends on the resistance of the wires connecting your telephone to the exchange. The farther you are from the battery, the higher the line resistance, and the less current available to you. This creates the effect that the current in short loops is relatively high, tending to make voices too loud, while in long loops the current is relatively low, forcing users to raise their voice.

To counteract this effect, the telephone contains automatic compensation circuits that adjust the current through the transmitter and receiver so that performance on a very long line is equal to that on a short line. Inside the traditional telephone instrument is a network of coils, resistors,

and capacitors that make up the equalization network.

At the heart of the this network is a variable resistor called a varistor that works in a manner just the opposite that of a resistor. Larger current flowing through it, increases its resistance, while smaller current, reduces its resistance. Placing a pair of varistors in series with the line, causes the negative-resistance characteristics of the varistors to stabilize current flow and minimize the effects of line resistance. Should you note any problems with this network, replacement of the entire network is recommended.

In the electronic telephone, a special circuit called an automatic gain control, or agc, compensates for line resistance by sampling the incoming signal and adjusting the gain of the electronic amplifier accordingly. Troubleshooting the network and amplifier portion of an electronic telephone is similar to repairing any electronic instrument. Voltage measurements and signal tracing are a must.

ME

Now available to everyone!

Computel Publishing Society

a unit of the
Computel System presents

Subscribe now—and become an official member! A subscription to Computel brings all of these exciting entitlements for the duration of the membership!

The one you've all been waiting for
Computel
PUBLISHED MONTHLY

ONE YEAR SUBSCRIPTION: \$14.00
CANADIAN: \$18.00 FOREIGN: \$24.00
(SAMPLE COPY: \$1.00) (BACK ISSUE: \$2.00)

- A membership Print Certificate—an honorable lasting meditation worth framing, created by the Computel Staff to signify membership in the Computel System!
- Hundreds of WARESALE and below-wholesale priced electronic gift items available, for your own personal use or for use with the Computel Merchandise Distribution Plan—a marketing technique for your own business!
- Group discounts when buying computer systems, supplies, and components with the other members of the Society, from huge closets and factory shutdowns that we are constantly working at for you!
- Discounted prices on computer hardware and software purchased through the Society at worldwide outlets!
- A comparison of the computer systems and equipment on the market FREE! you make an investment through Computel's advisory panel of members whose dedication in your locality will assist you on where to buy and where to get help!
- A multi-national magazine bulletin board for students, teachers, management personnel, Computer Hackers, Phone Phreaks, and anyone interested—spanning the world of Computers, Electronics, and Communication, joining the hobby and the profession in a spectacular display of creativity you won't want to miss!
- FREE advertising in Computel for members who wish to trade or sell their equipment, leave messages, just want to find out what's going on with other members—we will help you do it!

INFORMATION NEVER BEFORE PUBLISHED FOR THE PUBLIC!
Learn the secrets of computing!

COMPUTEL—the complete SOURCE for everyone. You can now do the things you've only heard about, right in the privacy of your own home. Indispensable reference for phreaks and hackers. Learn how to get all kinds of computer programs FREE. Get the inside story of big business systems—their quirks and flaws—and remain up to date with vital occurrences within the computer industry. Computel is a publication designed for everyone who has an intense curiosity about computer systems, containing a wealth of hard-to-find information that you just won't find elsewhere! Subscribe now, and join the thousands already progressed!

You will be in control of your computer with the only publication of its kind written for the user. Discover the secrets and learn the versatility of modern computer control concepts. Experiment with computer and telephone systems, interface them, learn how they work, what they do... AND HOW TO GET THEM TO WORK FOR YOU! A COMPLETE TELEPHONE ENGINEERING COURSE IS INCLUDED IN MONTHLY CHAPTERS. BRINGING YOU THROUGH STEP, CROSSBAR, ESS, BUBBLE, AND ATOMIC SWITCHING SYSTEMS! EXCLUSIVE COVERAGE IN BIOLOGICAL COMPUTING SYSTEMS, TOO! COMPUTERS AND TELEPHONES ARE THE FUTURE. THIS PUBLICATION IS AN ABSOLUTE MUST FOR EVERYONE INTERESTED!

THE CAPTAIN IS BACK...with an all new program for everyone!

•Check •Money Order •Postage •Cash	
The History of Computing	\$14.95
The History of the Telephone	\$6.95
The Phone Phreaks' Guide to Computers	\$19.95
Telephone Engineering Course	\$24.95
Computer Repair—Do it Yourself and SAVE!	\$24.95

ALL 5 REPORTS PLUS A SUBSCRIPTION TO COMPUTEL: \$69.00.

Computel Publishing Society

6354 Van Nuys Blvd., 161-B / Van Nuys, CA 91401-2696

Don't miss out. Subscribe now!

CIRCLE 29 ON FREE INFORMATION CARD

QUALITY ETCHED PC BOARDS IN LESS THAN 5 MINUTES.

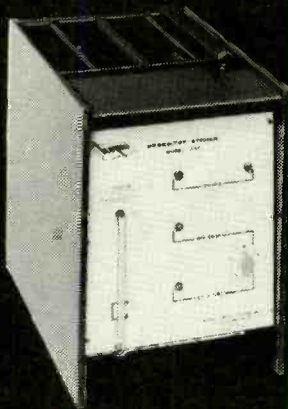

Convenient economical, high quality production of 12" x 12" panels is obtained using Kepron's Bench-Top Sprayer Etcher, only \$765. Kepron—the one stop source for all your Prototype and Short Run PCB needs.

kepron

Kepron Circuit Systems, Inc.

Write for full line catalog or call
1-800-325-3878 • 1-314-343-1630 (Missouri)

410 Axminister Drive • Fenton, MO 63025-2992

CIRCLE 28 ON FREE INFORMATION CARD

Now available for the computer experimenter!

COMPUTER CONNOISSEUR'S DELIGHT!

NOW BE IN CONTROL WITH YOUR COMPUTER — THE ONLY PUBLICATION OF ITS KIND WRITTEN FOR THE USER. DISCOVER THE SECRETS AND LEARN THE VERSATILITY OF MODERN COMPUTER COMMAND CONTROL CONCEPTS. EXPERIMENT WITH COMPUTER AND TELEPHONE SYSTEMS, INTERFACE THEM, LEARN HOW THEY WORK, WHAT THEY DO... AND HOW TO GET THEM TO WORK FOR YOU! A COMPLETE TELEPHONE ENGINEERING COURSE IS INCLUDED IN MONTHLY CHAPTERS. BRINGING YOU THROUGH STEP, CROSSBAR, ESS, BUBBLE, AND ATOMIC SWITCHING SYSTEMS! EXCLUSIVE COVERAGE IN BIOLOGICAL COMPUTING SYSTEMS, TOO! COMPUTERS AND TELEPHONES ARE THE FUTURE. THIS PUBLICATION IS AN ABSOLUTE MUST FOR EVERYONE INTERESTED!

UNPUBLISHED MATERIAL

WIT

COMICS

DIRECTORY LISTING NET-WORKS

ACCESS CODES

The one you've all been waiting for

NOW AVAILABLE—Learn how to repair telephones and telephone systems, how they work, in monthly installments with the magazine for you.

Computel

PUBLISHED MONTHLY

ONE YEAR SUBSCRIPTION \$14.00
(SAMPLE COPY \$2.00)
SUBSCRIPTION & 2 PROGRAMS \$20.00

COMPUTEL—the complete SOURCE for everyone. You can now do the things you've only heard about, right in the privacy of your own home. Indispensable reference to phreaks and hackers. Learn how to get all kinds of computer programs FREE. Get the inside story of big business systems—their quirks and flaws—and remain up to date with vital occurrences within the computer industry. Computel is a publication designed for everyone who has an intense curiosity of computer systems, containing a wealth of hard to find information, codes, and numbers. Published monthly.

Computel Publishing Society

6354 VAN NUYS BL., #161-A / VAN NUYS, CA 91401

CIRCLE 30 ON FREE INFORMATION CARD

MODERN ELECTRONICS MART

Classified Commercial Rates: 90¢ per word, 15-word minimum (\$13.50) prepaid. (Word count includes name and address, ZIP code and abbreviation each count as one word; P. O. Box number and telephone number count as two words each.) Indicate free category heading. A special heading is available for a \$6 surcharge. *First word only is set boldface caps* at no charge. Add 20% for additional boldface words.

Mart Display Rates: 1" x 1 col., \$120; 2" x 1 col., \$230; 3" x 1 col., \$330. Prepayment discount 5% for 6 issues; 10% for 12 issues prepaid at once.

(All advertisers with PO Box addresses must supply permanent address and telephone number. Copy is subject to publisher approval.)

Mailing Information: Copy must be received by the publisher by the 20th of the third month preceding the cover date. Send Advertising material with check or money order to: Modern Electronics, Classified Department, 76 North Broadway, Hicksville, NY 11801.

COMPUTERS

CONTROL your world with your computer! Control up to 48 devices easily. Interface your computer with robotics projects, radio control, home security and more. Unlimited potential! Complete plans, schematics, programs, \$12.95. SASE for more information. B&W Electronics, 3621 Lowden, Kalamazoo, Mich. 49008.

DESIGN your own custom circuits on your Commodore 64 or 128. Just enter specifications and the computer does the rest. Send \$5.00. Weaselgraphics Program Dept. ME586, 606 Thomasville, Pocahontas, AR 72455.

COMPUTER Text Adventures. APPLE, ATARI, C64, SPECTRUM. \$12.95-\$17.95. SASE Catalog. COMPUQUEST EIC, Box-492, St. Croix Falls, Wisconsin 54024.

TI-99/4A Software/Hardware bargains. Hard to find items. Huge selection. Fast Service. Free Catalog. Tynamic, Box 690, Hicksville, NY 11801.

TI-99/4A Discount Softwares: FREE Catalog from Microbiz Hawaii, POB 1108 Pearl City, HI 96782.

RENT PUBLIC DOMAIN SOFTWARE, IT'S NOT COPYRIGHTED, no fees to pay, Copy hundreds of useful business, utility and game programs from our rental libraries onto your own computer at home! National Public Domain Library, 1533 Avohill, Vista, CA 92083. (619) 941-0925. Recording—(619) 727-1015.

BASIC COMPUTERS, 10 lesson correspondence course, \$39.50. Certificate. Details free. AMERICAN TECHNICAL INSTITUTE, Box 201, Cedar Mountain, NC 28718.

IBM-PC programs; everything you need on 5 ds/dd disks; word processing, spread sheet, communications, data base, arcade games, and utilities. Send \$25.00 to ALT Software, 686 Longbrook Ave., Stratford, CT 06497.

ELECTRONICS

RESISTORS - any value/quantity, ¼ watt @ \$.01, ½ watt @ \$.015 (\$1.00 minimum). Quantity discounts, 1,000 + . Send wattage(s), value(s), quantity(s), and remittance - T.O.R.C.C.C. Electronics, Box 47148, Chicago, Illinois 60647; (312) 342-9171.

LASERS and Nightvision surplus components. FREE catalog, M.J. NEAL COMPANY, 6672 Mallard Ct., Orient, OH 43146.

RECONDITIONED Test Equipment. \$1.25 for catalog Walter's, 2697 Nickel, San Pablo, CA 94806, (415) 724-0587.

LINEAR PARTS, TUBES, TRANSISTORS —MRF454 \$16, MRF455 \$12, MRF477 \$11, MRF492 \$18. Catalog. RFPC, Box 700, San Marcos, CA 92069. (619) 744-0728.

PICTURE Flyer lists quality electronic surplus at low prices. Since 1970. Send for the last 3 issues. Star-Tronics, Box 683, McMinnville, OR 97128.

TEST equipment: Spectrum analyzers, microwave signal generators, counters, Tektronix scopes, power supplies. Free lists. Sheldon M. Rubin, 117 N. Ridge St., Rye Brook, NY 10573. 914-937-2535.

AUTOMOTIVE Security Alarm. Easy, inexpensive protection from theft. Plans \$4.95. Philtronics, Box 31085, Mpls., MN 55431.

Copy Worldwide Short-wave Radio Signals on Your Computer

Remember the fun of tuning in all those foreign broadcast stations on the short-wave radio? Remember those mysterious sounding coded tone signals that baffled you? Well, most of those beeps & squeals are really digital data transmissions using radioteletype or Morse code. The signals are coming in from weather stations, news services, ships & ham radio operators all over the world. Our short-wave listener cartridge, the "SWL", will bring that data from your radio right to the video screen. You'll see the actual text as it's being sent from those far away transmitters.

The "SWL" contains the program in ROM as well as radio interface circuit to copy

MICROLOG
INNOVATORS IN DIGITAL COMMUNICATION

Morse code and all speeds/shifts of radioteletype. It comes with a cable to connect to your radio's speaker/earphone jack, demo cassette, and an excellent manual that contains a wealth of information on how to get the most out of short-wave digital DXing, even if you're brand new at it.

For about the price of another "Pac-Zapper" game, you can tie your Commodore 64, 128 or VIC-20 into the exciting world of digital communications with the Microlog SWL. \$64. Postpaid, U.S. MICROLOG CORPORATION, 18713 Mooney Drive, Gaithersburg, Maryland 20879. Telephone: 301 258-8400.

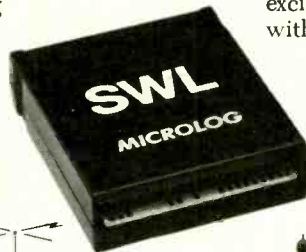

★ QUALITY PARTS ★ DISCOUNT PRICES ★ FAST SHIPPING!

ALL ELECTRONICS CORP.

SEND FOR
FREE
NEW 1986 CATALOG...
48 PAGES!

EDGE CONNECTORS

ALL ARE 1.56" SPACING.

- 22/44 EDGE CONNECTOR
PC style \$2.00 each
10 for \$18.00
- 22/44 EDGE CONNECTOR
solder lug style \$2.50 each
- 28/56 EDGE CONNECTOR
PC style \$2.50 each
10 for \$22.00
- 38/72 EDGE CONNECTOR
PC style \$3.00 each
- 43/86 EDGE CONNECTOR
PC style \$4.50 each

TRANSISTORS

- 2N705 4 for \$1.00
- 2N2222A 3 for \$1.00
- PN2222A 4 for \$1.00
- 2N2904 3 for \$1.00
- 2N2904 3 for \$1.00
- 2N2905 3 for \$1.00
- MJ2955 1 for \$1.50
- 2N3055 1000 for \$60.00
- PMD 10K40 \$1.00
- TIP 121 75¢
- TIP 125 75¢

TRANSFORMERS

- 120 volt primaries
- 5.6 volts @ 750 ma. \$3.00
- 6 volts @ 150 ma. \$1.25
- 6.3 volt @ 600 ma. \$3.00
- 12 V.C.T. @ 200 ma. \$2.00
- 12 V.C.T. @ 400 ma. \$3.00
- 12 V.C.T. @ 1 amp \$4.00
- 12 V.C.T. @ 2 amp \$4.85
- 12 V.C.T. @ 4 amp \$7.00
- 18 volts @ 650 ma. \$3.50
- 24 V.C.T. @ 200 ma. \$2.50
- 24 V.C.T. @ 1 amp \$4.85
- 24 V.C.T. @ 2 amp \$6.75
- 24 V.C.T. @ 4 amp \$9.50
- 24 V.C.T. @ 4 amp \$11.00
- 36 V.C.T. @ 135 ma. \$3.00

WALL TRANSFORMERS

- all plug directly into 120 vac outlet
- 4 VDC @ 70 ma. \$2.00
- 6 VDC @ 500 ma. \$3.50
- 6 VDC @ 750 ma. \$4.50
- 9 VDC @ 500 ma. \$5.00
- 12.5 VDC @ 265 ma. \$3.00
- 18 VDC @ 18 VA and 8.5 VDC @ 1.28 VA \$4.50
- 24 VDC @ 250 ma. \$3.00
- MULTI-VOLTAGE @ 500 ma. \$3.00
- 3, 4, 6, 7, 9 or 12 VDC \$7.50

MINI-BOX

Pomona #2104
Heavy-duty black phenolic project box with cover and screws. 2 3/8" X 1 1/2" X 1 1/2".
\$1.00 EACH

FUSES

- 3AG (AGC) SIZE 1, 1 1/2, 2, 2 1/2, 3, 4, 5, 6 AMP
- GMA SIZE 1, 2, 3, 4, 5 AMP
- of any ONE amperage 75¢

SOUND AND VIDEO MODULATOR FOR T.I. COMPUTER

T.I. # UM1381-1. Designed for use with T.I. computers. Can be used with video sources. Built-in A/B switch. Channel 3 or 4 selection switch. Operate on 12 vdc. Hook-up diagram included.
CAT# AVMOD \$10.00 REDUCED TO \$5.00 EACH

SPECIALS

1 AMP 50 VOLT DIODES
IN4001 TAPE AND REEL
100 for \$4.50
1000 for \$30.00

SOLDER TAIL I.C. SOCKETS
24 PIN 100 for \$2.50
1000 for \$20.00

SPECIAL PRICE TRANSISTOR
plastic transistor
PN3569 TO-92 N.P.N.
100 for \$8.00
1000 for \$60.00
LARGE QUANTITIES AVAILABLE

48 KEY ASSEMBLY FOR COMPUTER OR HOBBYIST

NEW T.I. KEYBOARDS. Originally used on computers, these keyboards contain 48 S.P.S.T. mechanical switches. Terminates to 15 pin connector. Frame 4" x 9"
CAT # KP-48 \$6.50 each
2 for \$11.00

TI SWITCHING POWER SUPPLY

Compact, well-regulated switching power supply designed to power Texas Instruments computer equipment.
INPUT: 14 - 25 vac @ 1 amp
OUTPUT: +12 vdc @ 350 ma.
+5 vdc @ 1.2 amp
-5 vdc @ 200 ma.
SIZE: 4 1/4" x 4 1/4" x 1 1/4" high \$5.00 each

13.8 VDC REGULATED POWER SUPPLY

These are solid state, fully regulated 13.8 vdc power supplies. Both feature 100% solid state construction, fuse protection, and L.E.D. power indicator. U.L. listed.
2 amp constant, 4 amp surge \$18.00 each
3 amp constant, 5 amp surge \$25.00 each

D.C. CONVERTER

Designed to provide a steady ±5 vdc @ 240 ma. from a battery supply of 3.5 to 6.25 volts.
2 1/16" x 3 1/16" x 1 1/16" \$1.50 each

MICRO-CASSETTE MECHANISM

Micro-cassette tape transport for standard MC60 or MC45 micro-cassettes. 3 Vdc operation. Contains: drive motor, belt, head, capstan, pinch wheel and other components. 3 1/2" X 2 1/4" X 5/8"
CAT# MCMEC \$3.00 each 10 for \$27.50

COMPUTER GRADE CAPACITORS

- 2,000 mfd. 200 vdc \$2.00
- 1 3/4" x 5" high
- 6,400 mfd. 60 vdc \$2.50
- 1 3/8" x 3 3/4" high
- 9,700 mfd. 50 vdc \$3.00
- 1 3/8" x 4 1/2" high
- 31,000 mfd. 15 vdc \$2.50
- 1 3/4" x 4" high
- 50,000 mfd. 40 vdc \$4.50
- 3" x 5 3/4" high
- 66,000 mfd. 15 vdc \$3.00
- 3" x 3 3/4" high
- 60,000 mfd. 40 vdc \$3.50
- 3" x 5" high
- 66,000 mfd. 15 vdc \$3.00
- 3" x 3 3/4" high
- 86,000 mfd. 30 vdc \$3.50
- 3" x 5 1/4" high
- 5,500 mfd. 30 vdc \$1.00
- 1 3/8" x 3 1/2" high
- 5,900 mfd. 30 vdc \$1.00
- 1 3/8" x 2 1/4" high
- 9,300 mfd. 50 vdc \$1.00
- 2" x 4 1/2" high
- 18,000 mfd. 10 vdc \$1.00
- 1 3/8" x 2 5/8" high
- 48,000 mfd. 10 vdc \$1.00
- 2 1/2" x 3 1/4" high
- 100,000 mfd. 10 vdc \$1.00
- 2 1/2" x 6" high
- 185,000 mfd. 6 vdc \$1.00
- 2 1/2" x 4 1/2" high

SLIM LINE COOLING FAN

Etr # 99XMI82 low noise fan. Measures 3 3/4" square x 1" deep. 21 cfm. 23 db. 1700 rpm
SPECIAL PRICE ... \$12.50 each

2K 10 TURN
MULTI-TURN POT
SPECTROL # MOD 534-7161
\$5.00 EACH

SOLID STATE BUZZER
Star # SMB-06L
6 vdc
TTL Compatible.
\$1.00 each
10 for \$9.00

± 12 Vdc or 24Vdc POWER SUPPLY

DELTRON MODEL QD12/15-1.7
Dual plus and minus 12Vdc open frame power supply. Can be used as 24Vdc @ 1.5 amp. INPUT: either 115 Vac or 230 Vac
Fully regulated computer grade supply.
7" x 4 3/4" x 2 3/4"
\$12.50 each 10 for \$110.00

220 Vac COOLING FAN

ROTRON # MX77A3
Muffin XL
220 Vac
4 1/8" square metal frame fan
CAT# CF-220 \$6.50 ea
10 for \$60.00 / 100 for \$500.00
QUANTITIES AVAILABLE

LINE CORDS

- TWO WIRE
6' 18/2 SPT-1 flat 3 for \$1.00
- 6' 18/2 SPT-2 flat 2 for \$1.00
- 6' 16/2 SJT round \$1.25 each
- THREE WIRE
6' 18/3 flat \$1.50 each
- 8' 18/3 round \$2.00 each

3 1/2" SPEAKER

8 ohm impedance. Full range speaker. 8 oz magnet 4" diagonal mounting centers.
\$2.50 each 10 for \$20.00

7 CONDUCTOR RIBBON CABLE

Spectra-strip red marker strip. 28 ga. stranded wire. \$5.00 per 100' roll

SPRING LEVER TERMINALS

Two color coded terminals on a sturdy 2 3/4" x 3 3/4" bakelite plate. Great for speaker enclosures or power supplies.
75¢ EACH 10 for \$6.00

XENON FLASH TUBE

3/4" long X 1/8" dia. Flash tube designed for use in compact camera flash units. Ideal for experimentors.
CAT# FLT-1 2 for \$1.00

MINIATURE TOGGLE SWITCHES

ALL ARE RATED 5 AMPS @ 125 VAC

- S.P.D.T. (on-on) PC style non-threaded bushing. 75¢ each 10 for \$7.00
- S.P.D.T. (on-on) Solder lug terminals. \$1.00 each 10 for \$9.00 100 for \$80.00
- S.P.D.T. (on-off-on) Solder lug terminals. \$1.00 each 10 for \$9.00 100 for \$80.00
- S.P.D.T. (on-off-on) PC style non-threaded bushing. 75¢ each 10 for \$7.00
- S.P.D.T. (on-on) PC lugs threaded bushing. \$1.00 each 10 for \$9.00 100 for \$80.00
- D.P.D.T. (on-on) Solder lug terminals. \$2.00 each 10 for \$19.00 100 for \$180.00

STANDARD JUMBO DIFFUSED T 1-3/4

- RED 10 for \$1.50 100 for \$13.00
- GREEN 10 for \$2.00 100 for \$17.00
- YELLOW 10 for \$2.00 100 for \$17.00

D.P.S.T. LIGHTED ROCKER SWITCH

115 vac lighted rocker. snap mounts in 3/8" x 1 1/8" hole. Orange lens. 16 amp contact.
\$1.50

FLASHER LED

5 volt operation red jumbo T 1 1/4 size \$1.00 each
NEW GREEN FLASHER CAT# LED-4G \$1.00

MINI-PUSH BUTTON

S.P.S.T. momentary normally open 1/4" bushing. Red button. 35¢ each 10 for \$3.00

BI-POLAR LED HOLDERS

Two piece holder for jumbo LED 10 for 65¢ 100 for \$5.00

SNAP ACTION SWITCH

Cherry elect. #E-21. N.O. or N.C. 0.1A contacts. Suitable for alarms and other low energy circuits. 1 1/2" lever.
45¢ EACH 10 FOR \$4.20

CLEAR CLIPLITE LED HOLDER

Make LED a fancy indicator. Clear. 4 for \$1.00

ROTARY ACTION MICRO

OMRON #C-5G3-C41
Clockwise action micro used in coin operated mechanisms and low torque operations.
RATED: 5 amps @ 125 Vac.
\$1.25 each 10 for \$11.00
LARGE QUANTITIES AVAILABLE

RECHARGEABLE NI-CAD BATTERIES

- AAA SIZE 1.25V 500MAH \$1.85
- AA SIZE 1.25V 500MAH \$1.85
- AA with solder tabs \$2.00
- C SIZE 1.2V 1200MAH \$3.50
- D SIZE 1.2V 1200MAH \$3.50

UNIVERSAL CHARGER

Will charge 4-AA, C, D, or AAA ni-cads or one 9 volt ni-cad at one time.
\$11.00 per charger

13 VDC RELAY

CONTACTS: S.P.N.C. 10 amp @ 120 vac
Energize coil to open contact.
COIL: 13 vdc 650 ohms
SPECIAL PRICE \$1.00 each

4PDT RELAY

14 pin KH style... 3 amp contacts... USED but fully tested \$1.70 each
Specify coil voltage desired
Either 24 vdc or 120 vac
LARGE QUANTITIES AVAILABLE

SOCKETS FOR KH RELAY

75¢ each

TOLL FREE ORDERS ONLY
1-800-826-5432
(ORDER ONLY)
(IN CALIFORNIA: 1-800-258-6666)
ALASKA, HAWAII, OR INFORMATION
(213) 380-8000 NO C.O.D.!!

QUANTITIES LIMITED
MINIMUM ORDER \$10.00
USA: \$3.00 SHIPPING
FOREIGN ORDERS:
INCLUDING SUFFICIENT SHIPPING
CALIF. RES. ADD 6 1/2%

ALL ELECTRONICS CORP.
LOS ANGELES, CA STORE
905 S. Vermont Ave.
#13 380-8000
VAN NUYS, CA STORE
6228 Sepulveda Blvd.
818 997-1806

MAIL ORDERS TO:
P.O. BOX 20406
Los Angeles, CA 90006
TWX - 5101010163 ALL ELECTRONIC
EASLINK MBX - 62887748



ADVERTISERS' INDEX

RS#		Page #
35	All Electronics Corp.	93
49	B&K Precision	18
-	C.O.M.B.	45, 89
171	Cleveland Institute of Elec.	21
31, 25	Communications Electronics	5, 47
29, 30	Computel	85, 91
-	Computer Direct	49
-	Dick Smith Electronics	59
34	Digi-Key Corp.	95
-	Grantham College of Engrg.	1
91	Health	4
62	Information Unlimited	71
30	J&W Electronics	71
28	Kepru	91
138	Lolir	65
27	MCM Electronics	73
-	McGee Radio	94
-	McGraw-Hill Book Club	31
166	Mercer Electronics	Cov. II
162	Microlog Corp.	92
33	Micro-Mart	81
-	NRI Schools	8, 11
-	Pacific Cable Co., Inc.	7
-	Protecto	15
23, 158	Radio Shack	3, Cov. IV
170	Ramsey Electronics	75
22	Salen Enterprises	90
46	Sibex Inc.	82
48	Synergetics	48
-	Unity Electronics	94
118	Wholesale Outlet	Cov. III

Free Product Information

Readers can obtain free information on products advertised by the above companies, as well as for some editorially mentioned products. Simply circle the appropriate number printed below an advertisement onto the Modern Electronics "Free Information Service" card bound into this issue. After filling in your name and address, just mail the postpaid card. Your request will be forwarded directly to the advertiser with a mailing label prepared by our reader-service department to ensure speedy response.

SPEAKER CATALOG

1001 bargains in electronics. Save up to 50% call toll free 1-800-346-2433 for ordering only. Order by VISA/MC/AMX. No COD's. Missouri, Alaska, Hawaii call 1-816-842-5092, or write McGee Radio, 1901 McGee St., K.C., MO 64108. Postage for catalog \$1.00.

NEW 20-PAGE CATALOG FREE

7 MILLION TUBES

Includes all current, obsolete, antique, hard-to-find receiving, transmitting, industrial, radio/TV types. **LOWEST PRICES.** Major brands in stock. **Unity Electronics Dept. M**
P.O. Box 213, Elizabeth, N.J. 07206



RESISTORS - any Value / Quantity, 1/4 watt @ \$1.01, 1/2 watt @ \$5.015 (\$1.00 Minimum). Quantity discounts, 1,000 +. Send wattage(s), value(s), quantity(s), and remittance - **T.O.R.C.C.C. Electronics**, Box 47148, Chicago, Illinois 60647; (312) - 342-9171.

SCANNER Hum 220 Hz, remove with simple circuit, for Bearcat, Regency. Print parts list \$4.50. Kit \$15.00. "Filter" 911 Monclair, Pensacola, Florida 32505. 904-432-8779.

CAPACITORS - Ceramic Disk - 50 Volts. All values @ \$0.10 plus \$1.00 shipping per order. **T.O.R.C.C.C. Electronics**, Box 47148, Chicago, IL 60647. (312) 342-9171.

\$\$\$\$ Super Savings on electronic parts, components, supplies and computer accessories. Free 40-page catalog for SASE. Get on our mailing list. **BCD ELECTRO**, P.O. Box 830119, Richardson, TX 75083 or call 214-690-1102.

BUILD this five digit panel meter with frequency counter, square wave generator, ohms/capacitance meter. Detailed instructions \$2.50. Refundable. **Bagnall Electronics**, 179 May, Fairfield, CT 06430.

CIRCUIT Boards, guaranteed lowest quotes and Free twelve hour prototypes. Single and double sided boards. Small through large production quantities. Mail specifications. - **Hobbyists**; any schematic, 6" x 9" maximum, etched on a 3" x 4" board - \$1.75. (larger boards -\$2.50). - Send remittance and schematic or artwork; or, **Print your own circuit boards**. Kits of all sizes. Guaranteed lowest prices. - Basic kit \$3.00; Materials for two 3" x 4" boards (included), or S.A.S.E. for catalog - **T.O.R.C.C.C. Electronics**, Box 47148, Chicago, Illinois 60647, (312) -342-9171.

VIDEO

BUILD Your Own Satellite TV Receiving System And Save! Instruction manuals, schematics, circuit boards, parts kits! Send stamped envelope for complete product listing: **XANDI**, Box 25647, Dept. 30M, Tempe, AZ 85282.

COMPUTER printout of all satellite look angles for your location \$9.95 DMF, 6690 7 Mile, S. Lyon, MI 48178.

CORDLESS TV TRANSMITTER used to conveniently transmit TV signals to remote television locations within a 200 foot range. Free information **CAMEO ENTERPRISES**, P.O. Box 63M, Accord, MA 02018 (617) 871-5611.

CABLE and SUBSCRIPTION TV secret manual. Build your own **DESCRAMBLERS**, converters. Instructions, schematics for sine wave inband/outband gated sync SSAVI (HBO, Showtime, Cinemax, UHF, etc.). Send \$8.95 to **CABLETRONIX**, Box 30502ME, Bethesda, MD 20814.

PAY TV and Satellite Descrambling. 73 pages. 5th edition. Schematics and theory for most systems including Fantasy, Anik, etc. \$12.95, MDS Handbook \$9.95. Product catalog \$1. **Shojiki Electronics Corp.**, 1327 E. Niagara St., Niagara Falls, NY 14303. COD's. 716-284-2163.

DESCRAMBLER Manuals, Sinewave, Gated pulse, SSAVI, \$4.00 each, all three \$10.00, **DNX**, 6690 7 Mile, S. Lyon, MI 48178.

CABLE TV CONVERTERS & EQUIPMENT. Plans and parts. Build or buy. **SEND SASE.** C & D ELECTRONICS, P.O. Box 1402, Dept. ME, Hope, AR 71801.

SATELLITE TV receivers, LNA's, etc. At wholesale prices. **Jake's**, Box 593, Brigham City, UT 84302.

CABLE TV Secrets - the outlaw publication the Cable Companies tried to Ban. HBO, Movie Channel, Showtime, Descramblers, Converters, etc. Suppliers list included. \$8.95. **Cable Facts**, Box 711-ME, Pataskala, OH 43062.

INVENTORS

INVENTORS! Can you profit from your idea? Call **AMERICAN INVENTORS CORPORATION** for free information. Over a decade of service. 1-800-338-5656. In Massachusetts call (413) 568-3753.

REPAIR YOUR OWN TV

NEW . . . REPAIR YOUR OWN TV . . . EASY. Write, **Research Rt. 3**, Box 601BW, Colville, WA 99114.

EDUCATION

SCHOLARSHIPS and grants matched to college bound students. Results guaranteed. For more information send \$2.00 for postage/handling. Include year in school to **SRA**, Box 110, Perth Amboy, NJ 08862.

COMMUNICATIONS

UNSCRAMBLERS, hear the coded messages of fire, police and emergency channels. Satisfaction guaranteed. **DNE Inc.**, Rt. 7, Box 257M, Hot Springs, Ark. 71901 501-623-6027.

COMMUNICATIONS PLANS, BOOKS, KITS! AM/FM broadcasting (licensed/unlicensed), 1750 Meter transceivers, ham/CB amplifiers, surveillance bugs, more! **FREE** catalog. **PAN-COM**, Box 130-ME4, Paradise, CA 95969.

ARMY RADIOS: CPRC-26 Infantry Backpack Radio, compact, transmits-receives 46-54 MHz FM, with battery box, antenna, crystal, handset: \$22.50 apiece, \$42.50/pair. PRC-9 Backpack Radio, transmits-receives 28-39 MHz FM continuous tuning, factory mint: \$52.50 piece, \$77.50 with good condition battery box, antenna, handset. R-390A Communications Receiver, .5-30 MHz all models: \$195 complete/checked, \$115 complete/repairable. R-748 Receiver, 130-150 MHz single channel AM: \$27.50. ARC-27 Aircraft Receiver, 220-248 MHz single channel AM: \$12.50 mint. 45 Day Replacement Guarantee. Add \$9.50 Shipping-Handling except R-390, shipping collect. **Baytronics**, Dept. ME, Box 591, Sandusky, OH 44870.

MISCELLANEOUS

ASIAN LADIES want correspondence for friendship, marriage. **SUNSHINE INTERNATIONAL**, Dept. TR, Box 260, North Hollywood, CA 91603.

30,000 receiving tubes from \$4 to \$10 each. Send stamped envelope for list. **Fox**, 22661 Glenwood, Mt. Clemens, MI 48043

\$10-\$360 WEEKLY/UP, Mailing Circulars! No Quotes. Sincerely Interested, Rush stamped envelope: **National Division**, Box 20728-MC4, San Diego, CA 92120.

NATIONAL SEMICONDUCTOR • PANASONIC MACHINE • EWING, INC. • INTERSIL • AD EAC, INC. • J. W. MILLER • AAVDI ENGINE E. F. JOHNSON • ATLANTIC SEMICONDUCTOR

256K (262,144 x 1) DRAM 150ns \$5.70/1; \$39.95/9

JODES • DIAMOND TOOL • UNGAR • EGAR • CW INDUSTRIES • AMDEK • G.E. YAGOR • YAGOR • J. W. MILLER • LUXO SC CHEMICALS • ARIES • PLESSEY

FACTORY FRESH

INTEGRATED CIRCUITS

Part No.	Manufacturer	Price
7400 TTL	74LS127N	1.10
7400N	74LS127N	1.10
7401N	74LS127N	1.10
7402N	74LS127N	1.10
7403N	74LS127N	1.10
7404N	74LS127N	1.10
7405N	74LS127N	1.10
7406N	74LS127N	1.10
7407N	74LS127N	1.10
7408N	74LS127N	1.10
7409N	74LS127N	1.10
7410N	74LS127N	1.10
7411N	74LS127N	1.10
7412N	74LS127N	1.10
7413N	74LS127N	1.10
7414N	74LS127N	1.10
7415N	74LS127N	1.10
7416N	74LS127N	1.10
7417N	74LS127N	1.10
7418N	74LS127N	1.10
7419N	74LS127N	1.10
7420N	74LS127N	1.10
7421N	74LS127N	1.10
7422N	74LS127N	1.10
7423N	74LS127N	1.10
7424N	74LS127N	1.10
7425N	74LS127N	1.10
7426N	74LS127N	1.10
7427N	74LS127N	1.10
7428N	74LS127N	1.10
7429N	74LS127N	1.10
7430N	74LS127N	1.10
7431N	74LS127N	1.10
7432N	74LS127N	1.10
7433N	74LS127N	1.10
7434N	74LS127N	1.10
7435N	74LS127N	1.10
7436N	74LS127N	1.10
7437N	74LS127N	1.10
7438N	74LS127N	1.10
7439N	74LS127N	1.10
7440N	74LS127N	1.10
7441N	74LS127N	1.10
7442N	74LS127N	1.10
7443N	74LS127N	1.10
7444N	74LS127N	1.10
7445N	74LS127N	1.10
7446N	74LS127N	1.10
7447N	74LS127N	1.10
7448N	74LS127N	1.10
7449N	74LS127N	1.10
7450N	74LS127N	1.10
7451N	74LS127N	1.10
7452N	74LS127N	1.10
7453N	74LS127N	1.10
7454N	74LS127N	1.10
7455N	74LS127N	1.10
7456N	74LS127N	1.10
7457N	74LS127N	1.10
7458N	74LS127N	1.10
7459N	74LS127N	1.10
7460N	74LS127N	1.10
7461N	74LS127N	1.10
7462N	74LS127N	1.10
7463N	74LS127N	1.10
7464N	74LS127N	1.10
7465N	74LS127N	1.10
7466N	74LS127N	1.10
7467N	74LS127N	1.10
7468N	74LS127N	1.10
7469N	74LS127N	1.10
7470N	74LS127N	1.10
7471N	74LS127N	1.10
7472N	74LS127N	1.10
7473N	74LS127N	1.10
7474N	74LS127N	1.10
7475N	74LS127N	1.10
7476N	74LS127N	1.10
7477N	74LS127N	1.10
7478N	74LS127N	1.10
7479N	74LS127N	1.10
7480N	74LS127N	1.10
7481N	74LS127N	1.10
7482N	74LS127N	1.10
7483N	74LS127N	1.10
7484N	74LS127N	1.10
7485N	74LS127N	1.10
7486N	74LS127N	1.10
7487N	74LS127N	1.10
7488N	74LS127N	1.10
7489N	74LS127N	1.10
7490N	74LS127N	1.10
7491N	74LS127N	1.10
7492N	74LS127N	1.10
7493N	74LS127N	1.10
7494N	74LS127N	1.10
7495N	74LS127N	1.10
7496N	74LS127N	1.10
7497N	74LS127N	1.10
7498N	74LS127N	1.10
7499N	74LS127N	1.10
7500N	74LS127N	1.10

T. I. C. SOCKETS

Part No.	Manufacturer	Price
1000 CMOS	74VHC00	1.10
1001	74VHC01	1.10
1002	74VHC02	1.10
1003	74VHC03	1.10
1004	74VHC04	1.10
1005	74VHC05	1.10
1006	74VHC06	1.10
1007	74VHC07	1.10
1008	74VHC08	1.10
1009	74VHC09	1.10
1010	74VHC10	1.10
1011	74VHC11	1.10
1012	74VHC12	1.10
1013	74VHC13	1.10
1014	74VHC14	1.10
1015	74VHC15	1.10
1016	74VHC16	1.10
1017	74VHC17	1.10
1018	74VHC18	1.10
1019	74VHC19	1.10
1020	74VHC20	1.10
1021	74VHC21	1.10
1022	74VHC22	1.10
1023	74VHC23	1.10
1024	74VHC24	1.10
1025	74VHC25	1.10
1026	74VHC26	1.10
1027	74VHC27	1.10
1028	74VHC28	1.10
1029	74VHC29	1.10
1030	74VHC30	1.10
1031	74VHC31	1.10
1032	74VHC32	1.10
1033	74VHC33	1.10
1034	74VHC34	1.10
1035	74VHC35	1.10
1036	74VHC36	1.10
1037	74VHC37	1.10
1038	74VHC38	1.10
1039	74VHC39	1.10
1040	74VHC40	1.10
1041	74VHC41	1.10
1042	74VHC42	1.10
1043	74VHC43	1.10
1044	74VHC44	1.10
1045	74VHC45	1.10
1046	74VHC46	1.10
1047	74VHC47	1.10
1048	74VHC48	1.10
1049	74VHC49	1.10
1050	74VHC50	1.10

DISC CAPACITORS

Part No.	Manufacturer	Price
PA001	500 75	6.48 48.71
PA002	150 75	6.48 48.71
PA003	300 75	6.48 48.71
PA004	450 75	6.48 48.71
PA005	600 75	6.48 48.71
PA006	750 75	6.48 48.71
PA007	900 75	6.48 48.71
PA008	1050 75	6.48 48.71
PA009	1200 75	6.48 48.71
PA010	1350 75	6.48 48.71
PA011	1500 75	6.48 48.71
PA012	1650 75	6.48 48.71
PA013	1800 75	6.48 48.71
PA014	1950 75	6.48 48.71
PA015	2100 75	6.48 48.71
PA016	2250 75	6.48 48.71
PA017	2400 75	6.48 48.71
PA018	2550 75	6.48 48.71
PA019	2700 75	6.48 48.71
PA020	2850 75	6.48 48.71
PA021	3000 75	6.48 48.71
PA022	3150 75	6.48 48.71
PA023	3300 75	6.48 48.71
PA024	3450 75	6.48 48.71
PA025	3600 75	6.48 48.71
PA026	3750 75	6.48 48.71
PA027	3900 75	6.48 48.71
PA028	4050 75	6.48 48.71
PA029	4200 75	6.48 48.71
PA030	4350 75	6.48 48.71
PA031	4500 75	6.48 48.71
PA032	4650 75	6.48 48.71
PA033	4800 75	6.48 48.71
PA034	4950 75	6.48 48.71
PA035	5100 75	6.48 48.71
PA036	5250 75	6.48 48.71
PA037	5400 75	6.48 48.71
PA038	5550 75	6.48 48.71
PA039	5700 75	6.48 48.71
PA040	5850 75	6.48 48.71
PA041	6000 75	6.48 48.71
PA042	6150 75	6.48 48.71
PA043	6300 75	6.48 48.71
PA044	6450 75	6.48 48.71
PA045	6600 75	6.48 48.71
PA046	6750 75	6.48 48.71
PA047	6900 75	6.48 48.71
PA048	7050 75	6.48 48.71
PA049	7200 75	6.48 48.71
PA050	7350 75	6.48 48.71
PA051	7500 75	6.48 48.71
PA052	7650 75	6.48 48.71
PA053	7800 75	6.48 48.71
PA054	7950 75	6.48 48.71
PA055	8100 75	6.48 48.71
PA056	8250 75	6.48 48.71
PA057	8400 75	6.48 48.71
PA058	8550 75	6.48 48.71
PA059	8700 75	6.48 48.71
PA060	8850 75	6.48 48.71
PA061	9000 75	6.48 48.71
PA062	9150 75	6.48 48.71
PA063	9300 75	6.48 48.71
PA064	9450 75	6.48 48.71
PA065	9600 75	6.48 48.71
PA066	9750 75	6.48 48.71
PA067	9900 75	6.48 48.71
PA068	10050 75	6.48 48.71
PA069	10200 75	6.48 48.71
PA070	10350 75	6.48 48.71
PA071	10500 75	6.48 48.71
PA072	10650 75	6.48 48.71
PA073	10800 75	6.48 48.71
PA074	10950 75	6.48 48.71
PA075	11100 75	6.48 48.71
PA076	11250 75	6.48 48.71
PA077	11400 75	6.48 48.71
PA078	11550 75	6.48 48.71
PA079	11700 75	6.48 48.71
PA080	11850 75	6.48 48.71
PA081	12000 75	6.48 48.71
PA082	12150 75	6.48 48.71
PA083	12300 75	6.48 48.71
PA084	12450 75	6.48 48.71
PA085	12600 75	6.48 48.71
PA086	12750 75	6.48 48.71
PA087	12900 75	6.48 48.71
PA088	13050 75	6.48 48.71
PA089	13200 75	6.48 48.71
PA090	13350 75	6.48 48.71
PA091	13500 75	6.48 48.71
PA092	13650 75	6.48 48.71
PA093	13800 75	6.48 48.71
PA094	13950 75	6.48 48.71
PA095	14100 75	6.48 48.71
PA096	14250 75	6.48 48.71
PA097	14400 75	6.48 48.71
PA098	14550 75	6.48 48.71
PA099	14700 75	6.48 48.71
PA100	14850 75	6.48 48.71

7400 TTL

Part No.	Manufacturer	Price
7400	74LS127N	1.10
7401	74LS127N	1.10
7402	74LS127N	1.10
7403	74LS127N	1.10
7404	74LS127N	1.10
7405	74LS127N	1.10
7406	74LS127N	1.10
7407	74LS127N	1.10
7408	74LS127N	1.10
7409	74LS127N	1.10
7410	74LS127N	1.10
7411	74LS127N	1.10
7412	74LS127N	1.10
7413	74LS127N	1.10
7414	74LS127N	1.10
7415	74LS127N	1.10
7416	74LS127N	1.10
7417	74LS127N	1.10
7418	74LS127N	1.10
7419	74LS127N	1.10
7420	74LS127N	1.10
7421	74LS127N	1.10
7422	74LS127N	1.10
7423	74LS127N	1.10
7424	74LS127N	1.10
7425	74LS127N	1.10
7426	74LS127N	1.10
7427	74LS127N	1.10
7428	74LS127N	1.10
7429	74LS127N	1.10
7430	74LS127N	1.10
7431	74LS127N	1.10
7432	74LS127N	1.10
7433	74LS127N	1.10
7434	74LS127N	1.10
7435	74LS127N	1.10
7436	74LS127N	1.10
7437	74LS127N	1.10
7438	74LS127N	1.10
7439	74LS127N	1.10
7440	74LS127N	1.10
7441	74LS127N	1.10
7442	74LS127N	1.10
7443	74LS127N	1.10
7444	74LS127N	1.10
7445	74LS127N	1.10
7446	74LS127N	1.10
7447	74LS127N	1.10
7448	74LS127N	1.10
7449	74LS127N	1.10
7450	74LS127N	1.10
7451	74LS127N	1.10
7452	74LS127N	1.10
7453	74LS127N	1.10

Add Stereo Sound To Your TV Receiver *(from page 64)*

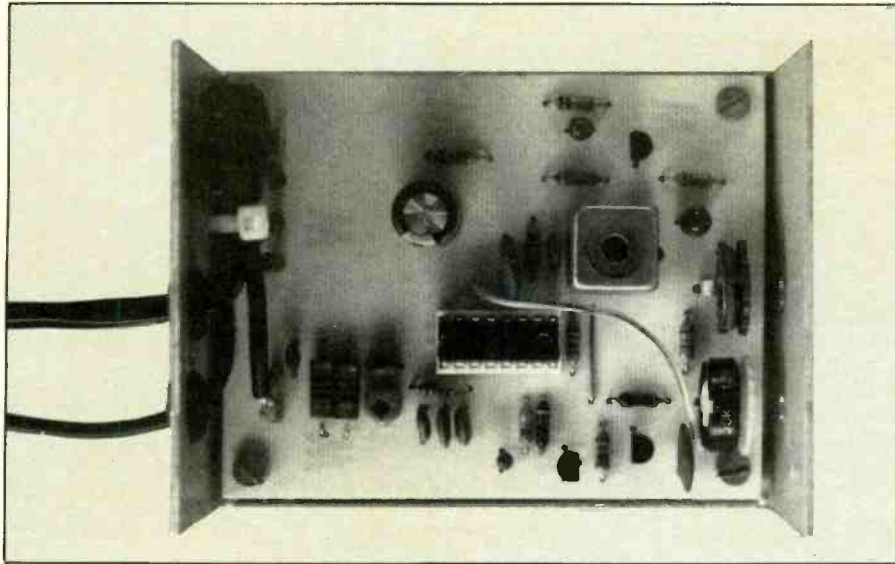

An interior view of the finished project.

driver with a metal shank for the alignment procedure.

If you already mounted the project on the back panel of your TV set, dismount it now and set SQUELCH control *R2* fully counterclockwise (minimum resistance) and VOLUME control *R11* to midposition. Plug the project's OUTPUT cable into the audio amplifier. If the amplifier has a treble control, set it for full cut.

Turn on your TV set and tune in a channel that's transmitting a stereo program. Carefully adjust fine tuning (if your set has this control) for optimum picture and sound quality. If your fine tuning is sloppy, you'll misalign the project slightly and will have to readjust the fine tuning for the other channels.

As you turn up the volume on the audio amplifier, you'll probably hear a noisy, distorted program. Adjust *C2* and then *L3* for maximum volume. Either of the two peaks you may find while making this adjustment is fine. Carefully adjust *L3* for maximum volume, and then touch up *C2* for minimum audible noise.

Tune the TV set to an unused channel. Adjust the SQUELCH control to slightly past the point where the rushing noise just disappears. Then tune

to an active channel and note that the sound comes on.

At this point, you should be getting excellent sound. This will be particularly noticeable if you're using a good-quality amplifier and speaker system. You may at this time be satisfied with obtaining high-quality monophonic sound and stop here un-

til you're ready to invest in a stereo TV converter. If so, connect a 0.01-microfarad capacitor across the OUTPUT cable to restore the treble to its normal range.

In Closing

Once you're satisfied with the results obtained with this project, it's time to add a stereo TV converter. There are many such converters on the market. If you want one with a built-in power amplifier to drive an extra set of speaker systems, you might consider Sony's Model MLV-1100. On the other hand, if you prefer to use your present stereo system, you can try Sears' No. 564.54390450 stereo adapter. Both converters work well with this project and are reasonably priced, especially the Sears unit at less than \$100.

To obtain stereo sound, connect the converter as indicated in the instructions supplied with it. If necessary, adjust VOLUME control *R11* for dependable, quiet stereo reception. Note that this is a very broad adjustment. Then sit back and enjoy great stereo sound. **ME**

A Versatile Printer Stand *(from page 55)*

acrylic cement. When the stand is fully assembled and the glue has set for about 24 hours, you are ready to paint it.

If you wish your wood stand to have a very smooth, professional finish, first rub onto all exterior surfaces a thin layer of Dap. This is a premixed plaster-like material that comes ready-to-use in a can. It dries white like plaster, but the color is immaterial, since you will be applying a paint, rather than a stain, finish. Allow the Dap to dry a couple of hours.

Gently rub down with very fine (No. 000) emery cloth to smooth the surface. Spray on a primer coat of paint and allow it to completely dry. Then spray on a coat of the color paint you plan to use for finishing (an enamel or gloss acrylic paint is best). Once again, allow the paint to completely dry. Then gently rub down the paint with fine steel wool (No. 000) and spray on the final finishing coat.

The Plexiglass/Lucite version is available in kit form, cut, slotted and polished (see note in Parts List). **ME**

COMPUTERS AT WHOLESALE

SMARTTEAM MODEM



103/212A-Operates at 300 BAUD and 1200 BAUD
 •BELL 103 and 212A compatible •HAYES compatible •Auto answer, dial and redial •External speaker for monitoring calls • AC adapter supplied
 Uses RS 232-C Connector.

No. 91990 **\$165⁰⁰**

COLOR GRAPHICS BOARD

RGB and Composite Port, Light Pen interface, Graphics 320 x 200 (color), 640 x 200 (BW), Text 25 x 80.

No. 92280 **\$72⁰⁰**

MULTI I/O CARD

Built-in Floppy Controller that can drive 2 floppy drives. Two RS 232 serial adapters. Timer Port, Parallel printer port, joystick adapter.

No. 96770 **\$88⁰⁰**

BUILD YOUR OWN COMPUTER SYSTEM

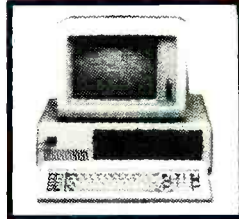

IBM® PC/XT-COMPATIBLE COMPUTER SYSTEM

IBM®PC/XT-Type Case: No. 90180 **\$39.00**
 150 Watt Power Supply: No. 90155 **\$79.00**
 IBM®-Type 5150 Keyboard: No. 90130 **\$49.00**
 Mother Board expandable to 640K with 128K included—
 No. SPCL01 **\$135.00**
 Monochrome Graphic Printer Board: No. 92270 **\$85.00**
 Floppy Drive Controller Board: No. 92260 **\$35.00**
 2 Floppy Disk Drives: No. 93140 at \$85 ea. **\$170.00**
 12" Magnavox TTL High Resolution Monitor with
 green-color Screen (amber color optional): No. 96710 **\$97.00**

YOUR COST: \$689⁰⁰
 Get components from such famous & reliable manufacturers as TEAC, Panasonic, Seagate, Magnavox, QUME, NEC, Hitachi, ITT, Mitsubishi & more!
 Any of the components may be purchased separately. All boards carry a 1-year warranty (2 years on Magnavox monitors).

KEYBOARDS



K150M—AT-look-a-like keyboard, made exclusively for XT's, with enlarged return key, cap lock & num lock.

No. 99020 **\$59⁰⁰**
 5151—features separate numerical & cursor pads/ function keys along top. LED cap lock & num lock.
 No. 51515 **\$79⁰⁰**

MAGNAVOX COLOR MONITOR



•RGB High resolution •14" diagonal •640 dots/H-240 lines/V-2000 characters •Built-in tilt stand.

No. 97890 **\$350⁰⁰**

POWER OUTLET STRIP



6 outlets with 15 amp surge protector & 6' cord. UL rated.

90140 **\$11⁹⁹**

SATELLITE SAVINGS — OUT OF THIS WORLD

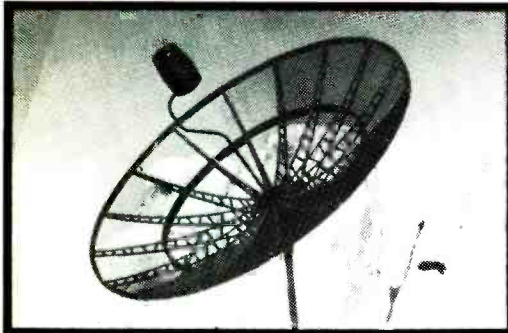

"SYSTEM A" FULLY UPS—SHIPPABLE SYSTEM

INCLUDES EVERYTHING YOU NEED:

- 6 ft. black mesh antenna
- WS-1000 receiver
- Amplica 100° LNA
- Polarizer Feedhorn Type I

SAVE OVER \$800
 COMPLETE SYSTEM

JUST **\$398⁰⁰**

COMPLETE SATELLITE TV SYSTEMS!

Join the age of Satellite TV and receive over 115 stations nationwide, including 24-hour prime time & sporting events. You can also receive HBO, Cinemax, ESPN, Playboy, Disney Channel and more!!

ORDER TODAY —
 YOU'LL SAVE TIME & MONEY, AND ENJOY WATCHING TV MORE THAN EVER!

WE CARRY A FULL LINE OF QUALITY SATELLITE EQUIPMENT—
 CHOOSE FROM UNIDEN, WILSON, AMPLICA & MORE!

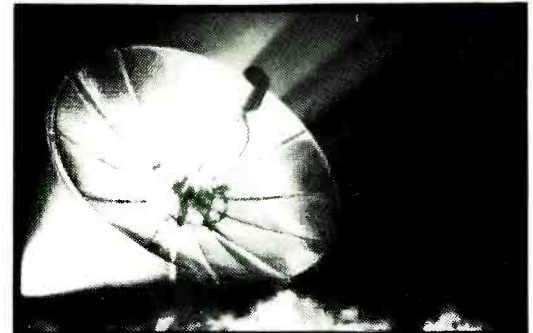

FULL SIZE "SYSTEM B" SATELLITE TV SYSTEM

Features all of the outstanding components of System A, but the dish you get is a full-size 9 ft. WILSON Airstream antenna. This famous dish has a true polar mount and is made of black mesh steel that withstands 100 mph winds. Includes handcrank and nose cone.

SAVE OVER \$1,000
 COMPLETE SYSTEM

JUST **\$489⁰⁰**



THE WHOLESALE OUTLET

1 INTERSTATE AVENUE, DEPT. ME, ALBANY NEW YORK 12205

CALL TOLL FREE: 1-800-344-4387 (NON-NYS) ALL OTHER CALLS AND NYS 518-459-7883. CALL FOR CATALOG WITH HUNDREDS OF OTHER ITEMS! ALL ORDERS SHIPPED FOB ALBANY. CUSTOMER PAYS FREIGHT AND HANDLING. CHECKS ACCEPTED (ON MAIL-IN ORDERS ONLY) AND YOUR ORDER IS SHIPPED WITHOUT DELAY! ALL OTHER ORDERS SHIPPED UPS COD (MONEY-ORDERS OR CASHIER'S CHECK ONLY.) MINIMUM ORDER \$25. (PRICES SUBJECT TO CHANGE WITHOUT NOTICE. WE ARE NOT RESPONSIBLE FOR TYPOGRAPHICAL ERRORS.)

IBM, PC, XT ARE REGISTERED TRADEMARKS OF INTERNATIONAL BUSINESS MACHINES, INC.



RADIO SHACK SATELLITE TV

The First Full-Featured System Designed for Easy Do-It-Yourself Installation

Radio Shack's new Home Satellite TV System brings you the winning combination of first-class performance, easy set-up, and a brand name you can trust. The 8 1/2-ft., horizon-to-horizon dish has a rotatable hub. You can assemble it from the ground with ordinary hand tools. The heavy-duty mast has a built-in bubble level for precise positioning. And the LNB is truly state-of-the-art, rated 80° for visibly clearer pictures.

For total remote-control convenience, the Realistic® receiver is preprogrammed with the correct audio, stereo mode and polarity on existing as well as future satellites. After easy initial programming, you simply select a channel and the system positions the dish automatically and locks-in the electronics for best reception. The receiver has outputs for standard TV sets and monitors, stereo audio amplifier and descrambler.

With illustrated instructions and video cassette installation guide, this complete block down conversion system is only \$1995. Or as low as \$92 per month with Radio Shack/CitiLine credit. Selected components are also offered for upgrading existing systems. Visit Radio Shack today.



Radio Shack®
The Technology Store™

A DIVISION OF TANDY CORPORATION
CIRCLE NO. 158 ON FREE INFORMATION CARD

Price applies at participating Radio Shack stores and dealers. CitiLine is an open-ended credit plan from Citibank. Actual payment may vary depending on balance.