

May 1978 \$1.50

modern electronics

Ⓜ 06707

Marine Electronics:
best gear for the new season
page 88

Pocket scanners
page 68

BASIC
easy self-instruction
in home computer
language
page 46

TVI
■ what it is
■ how to cure it
page 36

- 6 great projects**
- Star Wars sound effects
 - Cruise control
 - Westminster chimes
 - ModuClock
 - Thumb Thing
 - Power supply

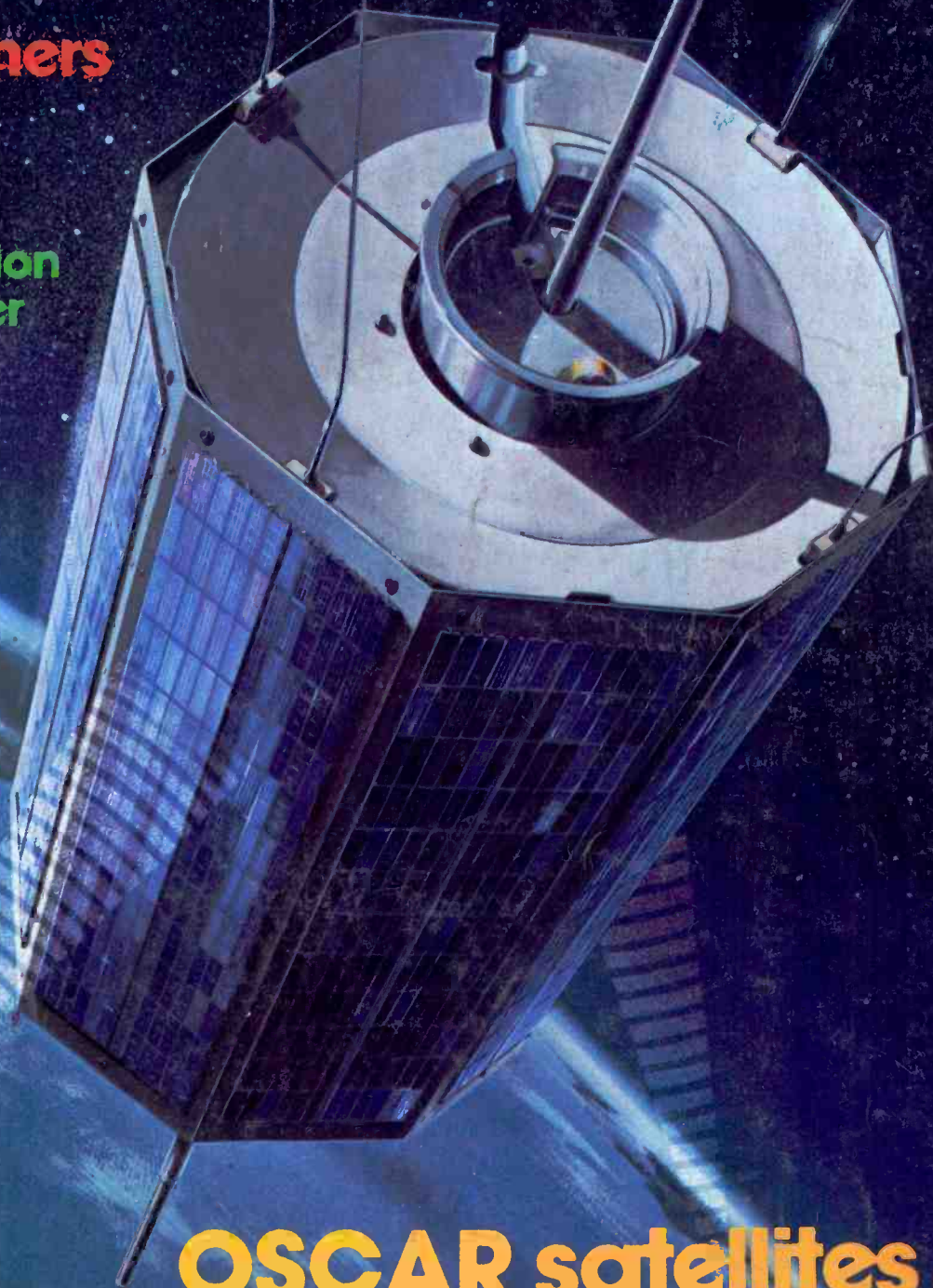

OSCAR satellites
how you can listen in
as hams talk through space
page 26





Jogging Computer

Make jogging fun in the privacy of your home with a new space-age indoor exercise system.

The JS&A Jogging Computer is a total system of physical fitness and conditioning.

It's a fact. You reach your physical peak at age 25 and your mental peak at age 40. From then on it's downhill. But it needn't be. A 50 year old who exercises regularly can be healthier and in better physical shape than the average 25 year old.

When you're physically healthy, you are alert and better able to handle stress. You are better motivated and just plain happier. Jogging can keep you in good physical shape.

THE ADVANTAGES OF JOGGING

Jogging as a regular exercise has gained in popularity because it does three things for you. 1) It improves the functioning of the heart, lungs, blood vessels and lymph glands. 2) It helps control your weight without resorting to starvation diets, and 3) It is one of the few safe, strenuous exercises that creates the exertion necessary for good physical conditioning.

A NEW JOGGING COMPUTER

There is now a new, fun way to jog. The new JS&A Computer is a solid-state system that lets you jog in place in the comfort of your own home. It's fun, easy to use and convenient.

You simply set the distance and pace you wish to run and press the start button. An audible beep tone sounds and you jog in place to its rhythm. Each stride is registered on a large LED readout in the control unit so you can see how far you've run.

You jog on a large pad with sensors which register each stride. The pad is designed to feel like grass or soft earth so you can run either barefooted or with gym shoes. The idea is to gradually increase your distance and speed each day to build up your endurance.

Getting yourself to start jogging is often the hardest step. That is why the JS&A Jogging Computer is an ideal system for both the beginner and the experienced jogger.

FOR THE BEGINNER

The first time you step on the Jogging Computer, you run at a pre-selected pace and distance for approximately five minutes. (A chart will show you which speed to select based on your sex and age.) You then take your pulse rate for one minute by touching your wrist. The pulse/rate chart determines the settings and distance you should run the next time you jog.

You could be in poor, average or good shape, and this simple five minute test will accurately tell you. Start the jogger at the distance indicated on the chart, and gradually build up a little each day. In just one week you'll notice the difference, feel great, have greater endurance, and you won't tire as easily. That is what's so nice about the system—how easily and quickly it puts you into better shape.

FOR THE EXPERIENCED

If you jog regularly, you know the many benefits of jogging. But you also know the disadvantages—all overcome by owning a Jogging Computer. For example:

Forget about the ritual You wake up early, drive to your favorite indoor track, change clothes, and you're ready to run. With the Jogging Computer, just step out of bed and start running. The time you save in preparing to jog can be substantial.

Forget about the boredom Running around a track can be quite boring. And if you count laps, how many times have you lost your count? With the Jogging Computer, you can forget about counting, as the unit does it automatically for you. You can concentrate on problems or take flights of fancy—all while you strenuously exercise.

Forget about the weather Even in summer, there are days when you can't jog outdoors. And in a daily exercise program, you must resort to the indoor track. Not so with the Jogging Computer. It's always there when you need it—portable and ready to operate.

Forget about jogger's heel If you've run on indoor tracks, you know the pain of jogger's heel caused by leaning in around those curves. Jogging in place is easier on your whole body and eliminates this common jogging problem.

BRING IT ANYWHERE

The Jogging Computer is powered by four "C" cell batteries and requires no AC power so it goes anywhere—on your patio, in the garage or basement, or at your office. The control unit can be propped up with its built-in easel or placed on a wall using the four foot expansion cord. It's portable, so after you've run a few miles, just turn it off and put it away. There's no large exercise device to take up space.

QUALITY THROUGHOUT

The JS&A Jogging Computer is all solid state, and the 17" x 22" pad was pre-tested to take years of constant, hard pounding under all conditions. Service should never be required, but if anything ever does go wrong, JS&A's service-by-mail center will have it repaired and back to you in a matter of days. Be assured that we stand solidly behind our product's quality, construction and design. JS&A is America's largest single source of space-age products. We've been in business over a decade—further assurance that your modest investment is well protected.

We suggest that you order the JS&A Jogging Computer and use it for 30 days. Jog each day when you get up in the morning or before dinner. Enjoy the thrill of feeling your endurance build. Experience the convenience and fun. See how much better you feel and how much sharper you think. Then after 30 days, measure your progress. If you don't find the JS&A indoor jogger a convenient and fun way to stay trim and healthy, then return your unit for a complete and full refund including the \$3.00 charge for postage and handling. You can't lose.

Simply send your check for **\$149.95** plus \$3.00 postage and handling (Illinois residents add 5% sales tax) to the address below or call our toll-free number. By return mail, we will send you the complete jogging computer system with instructions, charts, personal score card and a one year limited warranty.

Start today on an organized physical fitness program using the latest in solid-state, space-age technology. Order your JS&A Jogging Computer at no obligation today.

JS&A NATIONAL SALES GROUP

Dept. ME One JS&A Plaza
Northbrook, Ill. 60062 (312) 564-9000
Call TOLL-FREE 800 323-6400
In Illinois Call (312) 498-6900
© JS&A Group, Inc., 1978

WHY SETTLE FOR LESS— THAN A 6800 SYSTEM

MEMORY—

All static memory with selected 2102 IC's allows processor to run at its maximum speed at all times. No refresh system is needed and no time is lost in memory refresh cycles. Each board holds 4,096 words of this proven reliable and trouble free memory. Cost—only \$125.00 for each full 4K memory.

INTERFACE—

Serial control interface connects to any RS-232, or 20 Ma. TTY control terminal. Connectors provided for expansion of up to eight interfaces. Unique programmable interface circuits allow you to match the interface to almost any possible combination of polarity and control signal arrangements. Baud rate selection can be made on each individual interface. All this at a sensible cost of only \$35.00 for either serial, or parallel type

PROCESSOR—

"Motorola" M6800 processor with Mikbug[®] ROM operating system. Automatic reset and loading, plus full compatibility with Motorola evaluation set software. Crystal controlled oscillator provides the clock signal for the processor and is divided down by the MC14411 to provide the various Baud rate outputs for the interface circuits. Full buffering on all data and address busses insures "glitch" free operation with full expansion of memory and interfaces.

POWER SUPPLY—

Heavy duty 10.0 Amp power supply capable of powering a fully expanded system of memory and interface boards. Note 25 Amp rectifier bridge and 91,000 mfd computer grade filter capacitor.

DOCUMENTATION—

Probably the most extensive and complete set of data available for any microprocessor system is supplied with our 6800 computer. This includes the Motorola programming manual, our own very complete assembly instructions, plus a notebook full of information that we have compiled on the system hardware and programming. This includes diagnostic programs, sample programs and even a Tic Tac Toe listing.

Mikbug[®] is a registered trademark of Motorola Inc.

SWTP 6800

Computer System

with serial interface and 4,096 words of memory. \$395.00



- Enclosed is \$395 for my SwTPC Computer Kit Send Data
- or BAC _____ # _____
- or MC _____ Ex Date _____

NAME _____

ADDRESS _____

CITY _____ STATE _____ ZIP _____

Southwest Technical Products Corp., Box 32040, San Antonio, Texas 78284



The Touch

by Regency

16 channel scanner

\$239⁹⁸

SCANNER WORLD, USA now offers you the most advanced scanning monitor available in the world today — "The TOUCH," manufactured 100% in the United States by Regency, makers of the world's first transistor radio.

FEATURES AND SPECIFICATIONS

- ★ Search or scan. You can either search through all bands for unknown frequencies, or listen to the stored frequencies you've selected for the sixteen (16) scanning channels. Either way you can scan any combination of 16 channels in Lo, Hi or UHF Band, creating a total of 15,357 different frequencies available at your fingertips.
- ★ Frequency range Lo Band 30-50 MHz, Hi Band 146-174 MHz, UHF Band 440-512 MHz.
- ★ Receives all public service frequencies including police, fire, ambulance, mobile telephone, FBI, Customs, VHF marine, 2 meter amateur, plus many others.
- ★ Comes equipped with AC power cord for home use, DC power cord for mobile use, telescopic antenna and complete operating instructions for immediate use upon receipt.
- ★ Automatic scan delay momentarily stops the scanning after a call, to wait for a reply.
- ★ Has priority control switch so that you can automatically override calls on other channels and never miss a call on your favorite frequency.
- ★ Discover "Live" frequencies you never knew existed by activating automatic search with a single touch.
- ★ No crystals required — never buy another crystal.
- ★ One year warranty.
- ★ Weather alert receiver will automatically alert you in the event of a severe weather warning broadcast by the National Weather Service (subject to availability by local weather service transmitter).
- ★ Save over \$110.00 from manufacturers suggested list price of \$349.99 because of Scanner World's massive buying power.
- ★ From SCANNER WORLD, all of the above can be yours for only \$239.98 plus \$2.00 shipping. Call 518-436-9606 now to place a Master Charge or COD order by phone. Direct mail orders to the address below, including money order, Master Charge information, or we will ship your order COD. Catalogue \$1.00, free with order.



10—MENEW SCOTLAND AVENUE
ALBANY, NEW YORK 12208
518-436-9606

modern electronics

MAY 1978

CONTENTS

VOLUME ONE NUMBER THREE

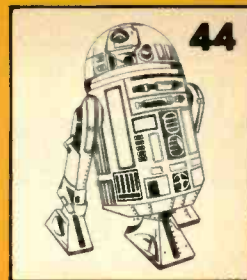

COVER STORY

26 OSCAR satellites: repeaters in the sky

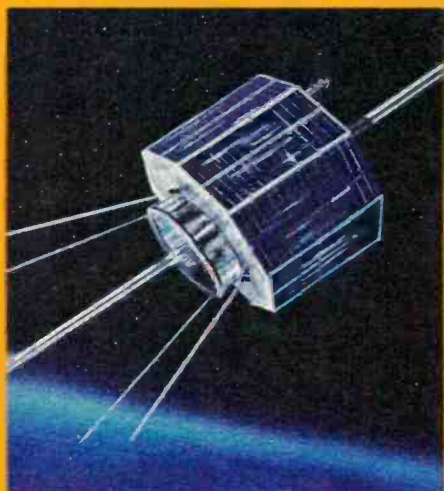

How to tune in ham radio space satellites

EDITOR

Anthony R. Curtis
K3RXK/W8TIZ

ASSISTANT EDITOR
Bob Margolin
K1BM/KAB#6647

CONTRIBUTING EDITORS
Judith G. Curtis
WB3AIG/KIE2647
Hans Fantel
Peter A. Stark
K2OAW

Ron Cogan
Jeffrey A. Sandler
Carmine W. Prestia
WB3ADI

Gerald R. Patton
WA3VUP

EDITORIAL ASSISTANT
Jeanne Lang

PRODUCTION MANAGER
David Fredericks

DESIGN CONSULTANT
Don Mannes

COVER ART
Fred Wolff

PUBLISHER
Richard A. Cowan
WA2LRO/KGE4096

Modern Electronics is published monthly by Cowan Publishing Corp., 14 Vanderventer Ave., Port Washington, NY 11050. Our title is registered with the United States Postal Service. Application for second-class postage is pending at Port Washington, NY.

SPECIAL FEATURES

36

TVI FCC official dope on how to cure interference from CB and ham to television and stereo

46 Computer Basic easy-to-understand story of the language for your home computer

68 Pocket scanners carry excitement in your lunch pail

60 Gear good stuff you'll want

34 Digital auto instruments readout fun in your car

80 Marine electronics everything you could want for boating this summer

58 Scanners Harold Perry saves a life



PROJECTS

44 R2-D2 sound effects

52 Thumb Thing tiny tester in a used film can

55 Westminster chimes add Heath's music to any clock

64 Modu-Clock red, green, yellow digits flash time

70 Power supply it's easy to change ac to dc

76 Cruise control add an electronic brain

MONTHLIES

5 Newscheck late news

6 Clinic readers try again to stump the editors

20 Gear new goodies

22 How it works equal time for TI

58 Comic book Harold Perry on scanning monitor receivers

60 Gear more good stuff you'll want

72 Program 3 different sets

92 Handbook notes on electricity

COLUMNS

4 Comment Tony likes OSCAR, hates TVI

8 Stereo Hans tells how to choose recording tape

12 Mobile Ron looks at new super stereo for car and van

14 Radio Judy finds an odd use for a CB walkie-talkie

17 Computers Pete on analog vs. digital

INFO

10 Sterec pointers what to look for when you buy a tape deck

57 Clocks how digital counters work

67 Soldering how to do it right

79 Schematics electronic symbols used in diagrams

comment

OUTPUT FROM MODERN ELECTRONICS' EDITOR

by Anthony R. Curtis
Editor, Modern Electronics

Amateur radio is one of the few hobbies around the world which contributes to the good of society. Hams have waded through floods, dug out of snow storms, talked half-sunk ships into harbor, located lost babies and stranded motorists, all placing their gear and operating expertise in the service of others.

Of course CB radio operators, computer hobbyists, and others in electronics often do good things for us all. But hams have the longest, most consistent record. When did you hear of a stamp collector using his hobby to save life or property?

Amateur radio dates to the beginnings of two-way wireless before the turn of this century. All of the first experimenters were amateurs since commercial systems hadn't been invented.

Which brings us to the crowning achievement of amateur radio hobbyists: space satellites. Modern Electronics is proud to salute ham ops everywhere with our coverage of OSCAR, the Orbital Satellites Carrying Amateur Radio (see our cover and pages 26-31). To have designed these birds for highly sophisticated communications-relay roles; to have built them in the home workshops of individual hams (see *Jan King: The Man Who Builds OSCAR Satellites* in Modern Electronics, March 1978); to control these satellites from Earth and use them to promote international understanding, goodwill and education is an achievement.

Meanwhile, April showers turn our attention to uncovering the old Stink Pot, hauling it down to the water and heading off on spring and summer cruises. This year, there's a ton of new electronic gadgets to make your on-the-water time super fun. Bob Margolin tells us all about the best and most fun on page 80.

We've talked a lot about home computers and the gear necessary to have your own. Now it's time to find out how exactly how one goes about talking with a Black Box. The most popular language for home-brew programs is Basic. Basic is a registered trademark of Dartmouth University. The letters stand for Beginners All-purpose Symbolic Instruction Code, or so we're told. At any rate, Basic is the most-used language for hobby machines. Pete Stark has put together a quick explanation of Basic starting on page 46. Read it and you'll be able to program your own computer today! And, so you won't have to write all of your own programs, we present three useful sets of instructions for your computer on page 72.

Star Wars is a blast. The R2-D2 robot probably is the most loved character in the movie. Dave Heiserman, who builds robots for himself, has designed an electronic gadget which you can build in one night with readily-available parts. The box will give you sound effects like those spoken by R2D2. Details are on page 44.

Television and stereo interference are the real pain for CB radio operators. Hams suffer too. Now the Federal Communications Commission (FCC) has pooled the immense resources of the government to find out what can be done about TVI. Starting on page 36, you'll find highlights of the FCC report.

Other goodies this month:

- Harold Perry has outdone himself, saving a child's life with a scanner on page 58.
- Ron Cogan tells how to install mo-fi in your car or van on page 12 and electronic cruise control for your car on page 76.
- Fred Blechman's Modu-Clock, page 64, is beautiful, with digital read-outs in three colors.

Dig in! Your going to love ME this month.



modern electronics

Business Staff

President and Publisher
Richard A. Cowan
Associate Publisher
Richard A. Ross
Vice President
Jack N. Schneider
Chairman of the Board
S. R. Cowan

Advertising Staff

Display Advertising
Richard A. Cowan
telephone (516) 883-6200
Midwest Sales Director
Jim Reilly
telephone (312) 824-2412
Circulation Manager
Janet Kurtz
Production Consultant
Cary L. Cowan

Art Staff

Art Director
William H. Travis
Assistant Art Director
Liz Beener
Design
Sheryl Stern
Illustrator
Harold Perry
Staff Artist
Fran Vitrano
Staff Artist
Tom Batcher

Property rights

All circuits, designs and construction projects in Modern Electronics are strictly experimental. We can't guarantee any results to be expected from their use or application. The publisher and editors do not know of any proprietary rights which could be violated by the making, building or using of any projects or gear described in this issue.

Freelance writers

Letters to the editors should be addressed to Modern Electronics, 14 Vanderventer Ave., Port Washington, NY 11050. Our editorial telephone is (516) 883-6200. We can't assume responsibility for unsolicited manuscripts but we will try to handle them courteously. Please mark your name, address and telephone number clearly on each page of manuscripts and on all photographs and artwork. Modern Electronics' readers demand manuscripts, photographs and artwork of the finest quality. Writers, photographers and artists meeting the standards of Modern Electronics' editors will receive prompt professional payment for submissions upon acceptance.

Change of address

Send us word of your change of address as early as possible. We need at least six weeks to make the change in our mailing list. Address changes and Postmaster form 3579 to Circulation Department, Modern Electronics, 14 Vanderventer Ave., Port Washington, NY 11050. Include your old address, new address and a mailing label from a recent issue of Modern Electronics.

Subscriptions

Mail subscriptions are available for \$12 a year or \$22 for two years. Newsstand cover price is \$1.50 per issue. Subscriptions are slightly higher for other countries. Write Circulation Department, Modern Electronics, 14 Vanderventer Ave., Port Washington, NY 11050. This magazine is printed in the United States of America.

Copyright

Copyright to the whole contents of Modern Electronics is held by Cowan Publishing Corp. 1978. You may not reprint any of our material without written permission from Cowan Publishing Corp.

news check ^{CB}

STOP THE PRESSES: LAST MINUTE NEWS JUST IN TO MODERN ELECTRONICS

BY ANTHONY R. CURTIS

PREACHING VIA SATELLITE IS THE latest venture for RCA and Trinity Broadcasting Network Inc. TBN will send Bible studies, kids' shows and Christian entertainment specials up to an orbiting RCA bird from Trinity's Earth station at KTBN-TV, channel 40, Tustin, CA. TBN will aim its around-the-clock religion at KPAZ-TV, Phoenix, AZ, immediately and later to Oklahoma City, Houston, Denver, Seattle and Honolulu.

FCC WATCHERS NEED TO KNOW the system of "docket" numbers is changed this year. New numbers start with a two-letter abbreviation for the FCC bureau proposing the rules change. That's followed by two numbers indicating the year and then a whole-FCC serial number. For instance, when the Broadcast Bureau (which governs your local disc jockeys) issues what might be the FCC's 43rd docket for this year, it would be labeled BC-78-43. Other abbreviations include SS for Safety and Special Services Bureau; CC for Common Carrier; CT for Cable tv; and GEN for general dockets from more than one of the FCC bureaus.

DOES HAM GEAR COST MORE THAN CB? Yes and no. Antenna tuners and two-meter radios are getting more reasonable price tags. But elaborate complete-station-in-one-box shortwave transceivers have so many bells and whistles add on that prices for newer packages are higher. Super new radios, glistening with pizzazz, were seen at a recent Las Vegas industry show with tags from \$1000-\$1500. The Cadillac's in the CB field, on the other hand, usually run \$500-\$1000.

HY-GAIN AND OTHER CB MANUFACTURERS are in deep trouble without enough sales of gear to keep the industry at the peak it hit many months ago. HY-GAIN reportedly is going into bankruptcy. Other former big CB names, like E.F. Johnson, are backing out of the unstable CB market. You'll still be able to buy good quality radios but there won't be 50-75 brand names on store shelves in the future.

IS RADIO DANGEROUS TO HEALTH? Probably not but the idea comes up from time to time that radio-frequency (rf) energy transmitted on the airwaves can hurt you. Now it's reported that the Governmental Affairs Committee of the U.S. Senate wants the U.S. Environmental Protection Agency (EPA) to become our federal watchdog over radiation hazards. By the way, radio waves at ultra-high frequencies (UHF) and microwave frequencies can burn human tissue. Never look into the barrel of Smokey's radar!

GEAR FACTORIES TURNING OUT stereo, CB, ham, computers, burglar alarms and all sorts of electronic equipment, are pinched between pressures from consumers to hold down prices and increases in prices charged by parts makers. Manufacturers of resistors, relays, switches and other essential elements of factory-built products have raised prices 5-10 percent this year. Watch for higher prices on electronic goodies.

BY JEFF SANDLER

Big gym turn on

My science class just built a digital scoreboard. It works fine, but the display is only about a half-inch high. Is there some way we can use it to drive the big scoreboard we have in our gym? That one uses strings of ten 15-watt bulbs to make up the number segments.

C.R., Massillon, OH

What you need is an interface capable of switching over an ampere of current for each segment. Although you could use triacs, I prefer to use relays because of the isolation they provide. Each segment is connected to the ac power line through a relay contact.

R = 2KΩ IF DRIVER OUTPUT IS 5 VOLTS.
R = 3.6KΩ IF DRIVER OUTPUT IS 6-10 VOLTS.
R = 5.1KΩ IF DRIVER OUTPUT IS 11-15 VOLTS.

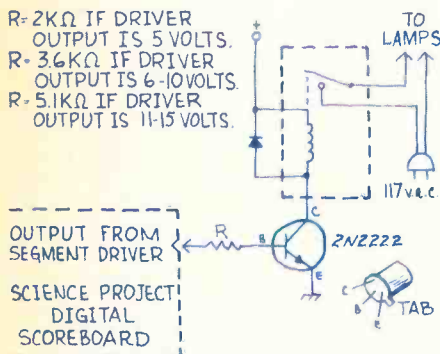

The relays are controlled by the segment drive lines of your digital scoreboard. Since the relay coils require much more current than the digital displays you're using, you need to add a transistor switch as shown. The collector voltage required depends on the relay you use. A Radio Shack 275-204 relay, for example, will operate from between six and nine volts. A 275-206 requires 12 volts.

IC breadboard cooker

A wisp of smoke is usually the first hint I get that I've cooked an IC. Is there some easy way to check out my breadboards so my errors show up before the ICs go south?

P.F., Carlingsford, CA

Obviously, the first thing to do is thoroughly check the wiring for errors and

shorts. About the only way to locate a design fault is to fire up the circuit and see what happens. If you can get your hands on a current-limited supply, you can calculate the maximum current the circuit normally will

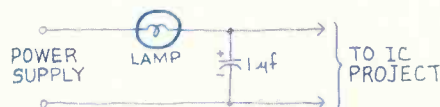

draw, and set the supply accordingly. Otherwise, you can use a pilot lamp in series with your circuit, as shown here. Choose the bulb type based on expected current flow from the following table:

Power supply voltage	Expected current (mA)	Bulb	Radio Shack number
0-3	0-15	-	272-1139
0-3	0-30	49	272-1111
4-7	0-15	-	272-1140
4-7	15-60	40	272-1128
4-7	60-200	PR12	272-1123
7-15	0-15	-	272-1141
7-15	0-60	1487	272-1134

Hope for an oldie

In my work I have to troubleshoot and repair solid-state circuits out in the field, away from power lines. I carry around a 12-volt battery pack for power, but I find the voltage regulation gets very poor as the batteries get old. Is there some way I can regulate the output voltage of a portable battery pack?

R.S., Belgrade, MT

You didn't state what kind of batteries you were using; some have better regulation than

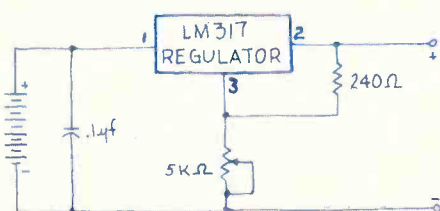

others. The new rechargeable sintered electrode NiCad batteries supply lots of current with good regulation. If you need really tight regulation, you can use a LM317 voltage

regulator IC as shown to provide a truly regulated variable voltage supply. With 12 NiCads, you'll get from 1.5 to 12 volts output at up to 250 mA for up to two hours before you'll have to recharge.

Wee-wee ringer

I just got a puppy for my son. She's a fine animal, but I'm having a real problem housebreaking her. She does fine during the day when we're around to correct her, but at night it's another matter. Do you have a gadget we can use to discourage her from travelling off the newspaper we leave?

T.Q., Vincennes, IN

I'm afraid I can't help you with general housebreaking problems. If you haven't already, check with your vet or an animal trainer. However, if your dog usually does

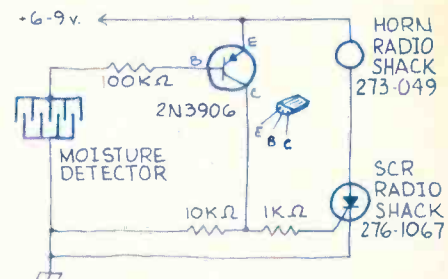

her thing in one or two places, you might try this moisture sensing alarm. The detector is made of fine wires spaced about one or two inches apart placed under a sheet or other porous cloth. Since it works on six to nine volts, there's little danger to the animal. When the area between a pair of wires becomes moistened, the horn will sound. This should take the place of your scolding and enforce your efforts to train her to paper. If nothing else, it'll let you know there's been an accident. Good luck.

Pinout pinups work

I recently purchased an assortment of integrated circuits from a national electronics store chain. When I wired them into my circuit following the pinout diagrams that came with them, the circuit

wouldn't work. I found out that the pinouts provided by the chain were wrong for some of the IC types I bought. How can I be sure I have the right data?

W.L., Little Rock, AK

The only way you can be 100 percent sure of the pinouts is to get them from the manufacturer. All of the large IC makers publish data books that give all the available information on every device they make. If you know someone in the industry, you can probably get the book you need free of charge. Otherwise, you'll have to pay up to \$20 each. But, if you're looking for data on only one or two devices, you can write the manufacturer for a free data sheet on each.

Torch for an old board

I've just obtained a boxful of computer circuit boards, each chuck full of working ICs. How can I salvage them with the least chance of damage? I don't care about the boards at all.

A.Y., Succasunna, NJ

While there are many desoldering tools and aids on the market, I've found this to be the best way to strip large IC boards of valuable parts. Fasten down the board using a bench vise, or even a pair of C clamps. Then play a one-half to 1½ inch flame from a butane or propane torch over the foil side of the board. In just an instant, the solder will melt. As it does, pull the IC off the component side with a pair of pliers or an IC holder. The whole process happens so fast, the ICs don't even get warm.

Idiot meter

During my vacation last winter, I found myself stranded out on a dirt road in the middle of Nevada with a dead battery. My car doesn't have an ammeter, just an idiot light. Maybe I missed it, but I never saw it light. How can I prevent this situation from happening again?

J.M., St. Paul, MN

This circuit should do the trick. It uses an LED and 4081 CMOS integrated circuit that are very reliable, and short of a collision, shouldn't fail to work. The variable resistor

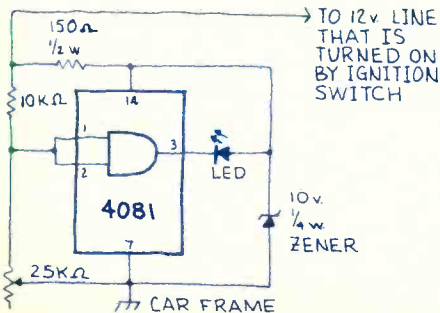

sets the voltage at which the LED turns on. Using a voltmeter known to be accurate, set the control so that the LED lights when the voltage from the car's ignition switch drops

below 13.8 volts. The LED normally will light every now and then for a short period of time. But, if it stays on for very long, your electrical system is in trouble.

Solder wick

Every now and then I have to remove an IC from one of my projects' printed circuit board. How can I avoid damaging the board when replacing an IC?

J.P., Butler, MO

If the IC is known to be bad, you can clip the leads with a pair of fine cutters as close to the IC as possible. Then, it's just a matter of removing one lead at a time from the board. If the IC is good, and you want to reuse it, you can use a desoldering wick, such as Radio Shack 64-2090. You can also make your own wick from a length of coax shield braiding, or even stranded wire from a lamp cord. Just dip the wire into liquid soldering rosin and let dry. Then place the rosin coated wire over the pad on your board and heat with your soldering iron. When the solder melts, it will flow into the wire and off the pad. When all of the pads have been cleaned of solder, the IC should slip out of the board easily. You may have to use the soldering iron on a solder bridge still left between an IC lead and the pad, but the hard work will be done.

Electric chips

I recently constructed a timer built around a 555 IC. The entire circuit only used 4 parts, yet I couldn't get it to work. What did I do wrong?

G.Y., Muncie, IN

It's impossible to diagnose all individual circuits. But, based on your letter and the diagram you sent, my guess is that you failed to connect the 555 to the power supply. Most schematic diagrams of circuits using ICs show only the logic symbols. Some may also include pin numbers on the leads going to the symbols, but few show power supply connections. It is understood that the IC will be powered. Newcomers to the hobby who aren't aware of those conventions in diagramming, often overlook providing power to the IC itself. However, Modern Electronics now provides IC powering information in project diagrams. If you're building projects from other sources, you may have to write the IC manufacturer for data sheets on the devices you're using.

6 to 12 converter

My job requires me to spend a lot of time on the road in a company car that doesn't have a radio. I've been using a portable radio propped up on the dashboard, but it runs through batteries faster than I can replace them. Is there some way I can

connect this six-volt radio to my 12-volt electrical system?

A.R., Warwick, RI

The easiest way to power a six-volt circuit from an automobile's 12-volt system is to buy a commercial adapter. Radio Shack, for example, sells a universal adapter (270-1561) for \$8.95. Although these adapters do the job, they do have some drawbacks. The voltage is fixed at one or two preset levels, and there is a relatively high no-load current drain. You can get around these, and save some money too, by building your own

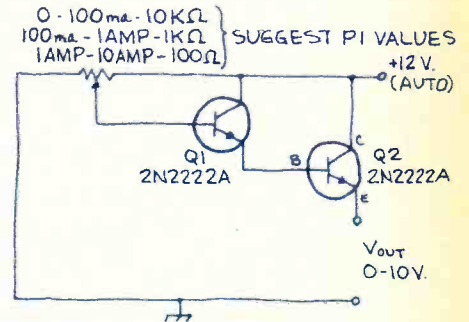

NOTE: THE LOWER THE VALUE OF PI, THE HIGHER THE STANDBY POWER CONSUMPTION

adapter. The circuit shown here uses just two transistors and a control. Q1 can be any low power NPN such as the 2N2222. If the load current is 40 ma or less, a 2N2222 can also be used for Q2. Higher load currents will require higher power transistors mounted in a heat sink. For loads of up to 100 ma, a 10,000 ohm linear control is ideal. The output voltage will be equal to the voltage between the control output and ground.

Turn it up

Every now and then the sound coming out of my radio becomes distorted, and sometimes, gets very soft. Can you tell me how to fix this problem?

L.T., Conalville, IA

Your radio is suffering from the most aggravating problem in electronics—the intermittent. Finding the cause of the intermittent in your radio may take a few minutes, or a few hours, even for a competent service technician. The first step is to tap the components and circuit board with the eraser-end of a pencil. If your trouble appears, the cause is in the area just tapped. If nothing happens, get a can of freeze spray, such as Radio Shack Freeze Mist 64-2321. Spray the components, one at a time until frost appears. If the intermittent appears, the last component sprayed is probably at fault. If this doesn't work, try heating each component with the tip of a soldering iron. Be careful not to over do it. To be safe, place a drop of water on the tip and plug in the iron. When it gets hot enough to boil off the water, unplug it—it's at the right temperature. If you still haven't found the trouble, a swift kick may help.

BY HANS FANTEL

Your cassette deck is only as good as the tape running through it. Here's how to choose which recording tape is best for you.

With all the different kinds of blank cassettes now on the market, it's no wonder that even savvy audio fans are getting a bit confused. Rival companies seem to be announcing new cassette types practically every month.

Granted, many of the new tape types use magnetic formulations providing wider frequency response and greater dynamic range than anything in the past; but the sheer variety of tapes presents a problem for the recordist who must adjust his tape deck to the specific requirements of these tapes—in terms of bias and equalization—to get optimum results.

To clarify these matters, let's go back to basics. As the carrier of the recorded sound, the tape largely determines what you hear. No recorder can be better than the tape running in it. No matter what the specs of your machine, the tape itself affects such vital factors as frequency response, the level of hiss, and dynamic range, the spread between the loudest and softest sounds that can be put on the tape.

Secret process

The working part of the tape is the magnetic layer coated on the plastic backing. This layer magnetically holds the musical signal and consists of microscopically small metallic oxide particles dispersed in a so-called *binder* substance.

Most manufacturers guard the formula for this oxide layer as jealously as a French restaurant chef guards the recipe for his Sauce Perigeux. It is the secret process of preparing the oxide and the binder that accounts for the characteristic sound of each tape brand.

Two basic types of magnetic materials are used in cassettes today. One is gamma ferric oxide (FeO_2), which is a kind of iron rust. The other is chromium dioxide (CrO_2). Each has advantages and drawbacks, thereby furnishing grist for non-stop arguments. In general, chromium tape provides stronger highs but tends to be a trifle weak at the low end. The results is a bright, punchy sound,



often preferred by rock and jazz fanciers. Ferric tapes may lack the glossy highs of the chrome tapes, but many listeners like their well-balanced frequency response and overall smooth sound.

Earlier chrome tapes often were somewhat abrasive, and as they rubbed against the recording head, they would cause those precision-ground metal parts to wear down more rapidly. Lately this problem has been overcome by improved binders and surface polishing. As a result, the latest chrome tape types—such as 3M's Scotch Chrome, BASF's Professional II, Memorex MRX2, Fuji FC, and the Advent Cassette—offer excellent high-frequency response at no undue risk to anyone's equipment.

Get the best of both

In addition to basic ferric and basic chrome tapes, two new formulations

have recently attracted much attention from audio fans eager to get top performance from their tape decks. These are known as *ferrichrome* and *ferricobalt* tapes.

In ferrichrome tapes, such as the Scotch Master III or the Sony FeCr, a thin chromium layer is placed on top of a ferric layer so the high frequencies are recorded by the chrome while the lows register in the iron particles. In short, each part of the musical range finds its most congenial recording medium. The idea is to combine the separate advantages of chrome and ferrite in a single tape.

In ferricobalt tapes, by contrast, there are no multiple layers. Instead, each tiny iron grain is bonded to a molecule of cobalt by a tricky chemical process. This increases sensitivity to high frequencies and also improves the signal-

If you think you can't learn TV and audio servicing at home, I say, "BALONEY!"

Maybe you don't believe that we can actually teach you to service TV and audio equipment by mail. Yet here at NRI, we're doing it every day. Helping people to bigger and brighter futures. Let me tell you why the NRI way works so well... and challenge you to put us to the test.

One of the secrets of the success of this school is the fact that its founder, J.E. Smith, was a teacher. So, when he originated his first course in radio over 60 years ago, it was carefully designed with training in mind. And that principle has guided us ever since. In every technical course we offer. Today, every aspect of our courses in TV and audio servicing are student-oriented to make learning as fast and as easy as possible.

Exclusive Training Methods

Right off, that means that you get far more than book learning. NRI gives you practical, hands-on experience as you progress. In our Master Course in TV and audio servicing, you actually construct a 25-inch diagonal solid state color TV. You start right with the basic parts and as you build it, you introduce and correct typical servicing problems, ending up with a complete unit, ready to use. That way, you get the actual bench time and intimate knowledge you need to handle real servicing problems. And before that, you even assemble some of your own electronic test instruments so you not only know how to use them, but how they work. That kind of training sticks with you... gives you extra confidence.

And Mr. Smith taught us something else, too. Not to go too fast. So, our courses have what we call "bite-size" lessons. That's another way of saying that they're easy to digest. Big enough to cover a specific subject thoroughly, but not so much that it'll overwhelm you. Written clearly, without a lot of gobbledegook. And we keep in mind that you're learning at home, so you take our lessons at your own pace. That way, you can learn in your spare time without interfering with your present job or eating up too much of your family life. Of course, if you want to move ahead faster, we're behind you all the way. The point is, it's your choice.

Professional Instructor/Engineers

One of the ways we back you up is with a fully-qualified staff of professional instructor/engineers. They're there to help you when you have a problem with any aspect of your studies... lessons, theory, bench training. And because most of them



John F. Thompson, NRI President

actually helped plan your lessons and designed your equipment, you'll get answers right from the horse's mouth, answers that are clear and to the point.

I might add that these are not a bunch of ivory-tower professor types. In between checking your lessons and giving you personal help, they're busy keeping up with the state of the art, designing new equipment and revising lessons to get you ready to handle even the latest equipment. As a case in point, take the audio equipment we added to our course recently. Not just stereo, but *four-channel*. Maybe a little exotic, but when a servicing problem like this hits your bench, you're ready for it. It's the kind of thinking and planning ahead our founder would have liked.

I Dare You To Do It

Now you might think I'm bragging a little too much on how good NRI is, and maybe I am. I'm mighty proud of our accomplishments. But the proof of the pudding is in the eating... how our training works in preparing people for actual jobs. So I'm inviting you to ask the only people who can give you a totally objective answer, professional TV and audio technicians. And here's my bet. Just look in your yellow pages for a couple of TV repair shops, ask to speak with anyone who actually does the repair work, and ask him what he thinks of NRI. I'll bet he says, "Do it!"

I'm not really sticking my neck out, because I know something you may not. Almost half the TV servicemen working out there have taken home-study courses. And among them, it's NRI more than three to one! Ask the pros on the firing line and three to one they'll recommend NRI to you as their first choice. I'll be happy to send you a copy of the national survey that proves it.

Why do the pros like us? Because NRI works. You take it at home so you don't have to go to classes. You take it in your spare time, so you can hold down your job while you get ready for your step forward. And you take it easy, because our

bite-size lessons make it easier, let you set your own pace.

Equipment Designed for Learning

And to top it off, NRI's equipment is exclusive. We design most of our own, so it's not somebody else's hobby kit or a stripped-down and mostly assembled commercial unit. It's designed so you really learn as you build, designed to give you lots of honest bench time, designed to give you the satisfaction of finishing up with a fully operable, top-quality unit that's comparable to any commercial set on the market. But you built it... you learned something on it! That's J.E. Smith's philosophy again.

It all boils down to the fact that we've aimed our training at a very practical goal... giving you the skills you need to move ahead in a rewarding career. Or even to have your own full- or part-time business.

Send for Free Catalog, No Salesman Will Call

There's lots more to tell about NRI training in TV and audio servicing and other courses, but not much space left to do it. So I'm inviting you to send for our free catalog of electronics courses. It contains a complete description of every course, including each lesson, training kits, and experiments. Full color photos show you exactly what your course will include in the way of test instruments, electronic components, and major kits like the 4-channel audio center and color TV.

No salesman will call on you, either. We don't work that way, never have. Our catalog shows you what we have to offer you, what we can do for you. Look it over, then think about it and make your own decision without outside pressure. J.E. Smith always felt that his best students were the self-motivated ones.

I can only add this. With over 60 successful years and more than a million students behind us, we must be doing something right. Just ask anybody we've helped along the way. So get started on your future. Send the postage-paid card and check the course that interests you. If it has already been removed, write me and I'll personally see that your catalog gets rushed to you. And thanks for listening to me.



John F. Thompson, President
NRI Schools
McGraw-Hill Center for
Continuing Education
3939 Wisconsin Avenue
Washington, D.C. 20016

CIRCLE 9 ON READER SERVICE CARD

to-noise ratio so the spread between soft and loud is greatly expanded. This sophisticated technology has resulted in some truly splendid-sounding tapes, such as TDK's SA (Super Avilyn), the Nakamichi SX, Maxell's UDXL-II, and 3M's Master II. On good components, these tapes will rival the sound of a fine disc recording.

From the user's point of view, the variety of available tapes is welcome. But keep in mind that three of the four current tape types—ferric, chrome, ferrichrome, and ferricobalt—require different adjustments of your cassette deck. Many ferricobalt tapes can be used with the *chrome* setting. Only if equalization and bias are properly adjusted for the particular type tape can you expect the tape to do its best. On most cassette decks, equalization and bias selectors are combined in a single switch. On more elaborate models, a separate control is provided for each.

Nobody knows why

The equalization switch (calibrated in microseconds) adjusts the frequency balance during recording so that, in playback, all notes will be given their proper due, with neither highs nor lows too loud or too soft. The bias function concerns a rather mysterious aspect of magnetism that is not yet fully understood—not even in theory.

In order to accept the signal to be recorded, the tape has to be primed by a so-called *bias current*, a high-frequency signal far above the audible range. This bias frequency must be applied to the tape along with the music. Nobody knows why. But it has been found by experiment that different kinds of magnetic tape require bias signals of different frequency and strength. Unless the proper bias is applied, the sound gets either too bright or too dull, and distortion increases noticeably.

The simplest bias selectors have two positions: one marked *normal* for ferric tapes and one for *chrome*. Some have a third position for ferrichrome, marked FeCr. Some equipment manufacturers recommend a certain kind of tape be used with their deck for best results. It's a good idea to follow these suggestions.

I make my own informal tests for matching recorder and tape type without benefit of any elaborate measuring devices. I just record the interstation hiss from my fm tuner. This makes an excellent test signal because the noise contains a random distribution of frequencies throughout the entire spectrum. Then, as I play back the recording, I switch back and forth between the tape and the original noise received over the air, and I stick with the tape brand that comes closest to the original sound. 

Tape deck shopping made easy

When you're in the market for a tape deck, it's confusing to know what to look for. What's the difference between 8-track and cassette decks; what controls are essential; what do all the terms and specifications mean?

This short guide to tape decks will help you decipher the specs so you can decide what deck you need.

Tape decks record and playback sound upon your command. The record part of the deck is like any tape recorder, requiring a microphone to pick up sounds in a room or a direct connection to a radio, record player, tape recorder or other electronic sound source.

The playback part of a deck provides a weak sound which must be amplified before it can be heard from a loudspeaker. You don't hook the deck directly to a loudspeaker. Rather, an *amplifier* must come between the deck and speaker. Such an amplifier can be a separate unit or it can be the amplifier built into a stereo receiver.

Tape decks have both electronic and mechanical parts. The mechanical parts make up the transport which moves the tape past a head. The *head* is a tiny cube with a slit. The head looks at the magnetic recording tape as it passes the slit.

Changes in the magnetism of the tape, caused by having sound recorded on it, are read by the head. The head changes the magnetism it senses into electrical impulses. Those impulses are sent to a *preamplifier* where they are boosted to a weak audio level. From the preamplifier, inside the deck, the weak sound goes to output jacks on the deck. Wires take the sound from those output jacks to tape input jacks on the stereo receiver.

Different packages

One way to package recording tape is in a *cartridge*. A tape deck's head can be made to look at only selected parts of a piece of tape. With an 8-track cartridge, the tape deck playback head is set to look at eight different tracks along the tape. The eight tracks are grouped as four pairs so you can have a left-channel and a right-channel stereo sound. Manufacturers refer to each of these four stereo pairs as a program. An 8-track tape deck plays, and some models record, only on 8-track cartridges.

Another means of packaging tape is in *cassettes*. They are smaller than cartridges and only hold one pair of stereo sounds from end to end. In effect, they have only one program, but it may be as long or longer than the total length of four programs in a cartridge.

Controls to do everything

Tape decks have such controls as fast forward, rewind, eject, tape counter and the like. *Fast forward*, found on all cassette machines and on better 8-track decks, allows you to speed the tape ahead to different sound. *Rewind*, available only on cassette decks, permits running the tape backward to replay something you liked. *Eject* helps you get the tape from the mechanical transport in the deck.

A *tape counter*, found only on cassette decks, shows a number. As the tape moves forward, the number advances. Such a counter lets you return exactly to a favorite part of a cassette if you remember the number at that tape location.

When a cassette tape plays all the way through to its end, *automatic shutoff* stops the forward motion and turns off power to the deck. You can walk away from the deck, while it is playing, knowing that it will turn itself off even if you forget. Only better-quality 8-track decks have such shutoff. It usually comes at the end of the fourth program.

Watch the meter

Those dual windows in tape decks with moving pointers are called VU meters. They tell you, while recording, whether the microphone volume is turned up enough. You can make the left-side mic louder than the right, or vice-versa, in a stereo recording, if you like.

Music tapes often have a weak hiss in the background which you can hear. *Dolby* is a special electronic circuit in better tape recorders to remove the hiss. Some fm radio stations have taken to broadcasting music with Dolby filters to remove hiss from their over-the-air sounds. A receiver with Dolby built in is necessary to get the hiss-removal effect.

When listening to music, you'll want the best sound with the least background of noise. Buy the highest *signal-to-noise* ratio number you can afford in tape decks, turntables, stereo receivers. —Judy Curtis 

The most important piece of electronic equipment you'll ever own.

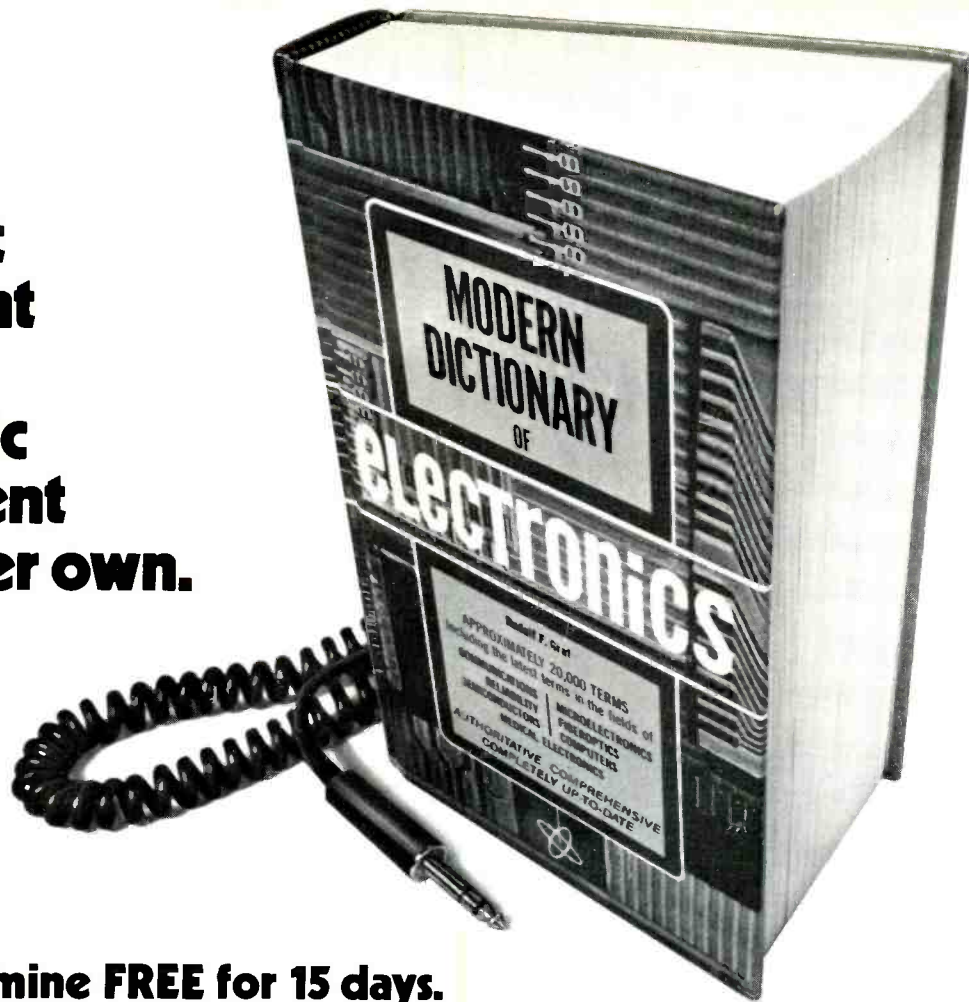

Yours to examine FREE for 15 days.

245

INCLUDES ALL THE LATEST TERMINOLOGY FOR SUCH FIELDS AS:

- Communications
- Microelectronics
- Fiberoptics
- Semi-conductors
- Reliability
- Computers
- Medical
- Electronics

LOOK at all the valuable "extras" this one handy reference volume contains:

- Hundreds of easy-to-grasp ILLUSTRATIONS AND DIAGRAMS—positioned with the terms they depict—and clearly captioned for quick understanding.
- CROSS-REFERENCED to aid you in locating those terms which you might look for in more than one place. Example: When looking up "Esaki diode" you'll be referred to "tunnel diode."
- Helpful PRONUNCIATION GUIDE of more than 1100 often-mispronounced electronic terms showing syllabic division as well as the newest, most-accepted pronunciation of each term.
- A newly-revised list of SEMI-CONDUCTOR SYMBOLS AND ABBREVIATIONS for use in semiconductor device data sheets and specifications.
- Clearly-illustrated SCHEMATIC SYMBOLS.
- GREEK ALPHABET. A special table lists the letters along with technical terms for which these letters are used as symbols (Name and Designates).

819 Pages of crystal-clear definitions. Over 18,500 terms defined and alphabetically arranged. Size: 5-1/2 x 8-1/2.

- Authoritative • Comprehensive • Completely up-to-date

BE OUR GUEST. Examine the MODERN DICTIONARY OF ELECTRONICS free for 15 days. Discover why book reviewers and some of the most demanding electronics experts around are calling it the most complete, up-to-date, authoritative dictionary ever compiled for this exacting field. And get a FREE \$4.95 bonus book.

Since rolling off the presses this giant reference is already being hailed as *THE* dictionary of the industry by thousands of electronic engineers, technicians, experimenters and hobbyists from coast to coast. So don't be surprised if it becomes one of the

most dogeared, coffee-stained books on your reference shelf.

Users tell us that one of the things that sets it head and shoulders above other electronic dictionaries is all the valuable *extra information* it contains. But see for yourself. Send for the MODERN DICTIONARY OF ELECTRONICS today. If you don't agree it's one of the most important pieces of electronic "equipment" you could own, simply return it within 15 days and owe nothing. And no matter what you decide, you'll get a free copy of "How to Read Schematic Diagrams" to keep...as our "thank you" gift.

FREE TRIAL COUPON



YOURS FREE...

"How to Read Schematic Diagrams" A \$4.95 value...keep it—even if you decide to return the DICTIONARY. **SAVE** postage and handling costs. Full payment enclosed (plus tax where applicable). 15-day return privilege still applies. (Prices subject to change without notice)

Yes. Please rush me the MODERN DICTIONARY OF ELECTRONICS (#21488*) for my free trial. I understand if not completely satisfied I may return it within 15 days and owe nothing. Otherwise, it's mine to keep for only \$18.95 plus postage and handling and local taxes (where applicable).

Name _____
Address _____
City _____
State _____ Zip _____

Mail to:
Howard W. Sams & Co., Inc.
4300 W. 62nd St.,
Indianapolis, Ind. 46260

EW41

BY RON COGAN

Control your own audio mixing with today's latest stereo accessories for your car or van.

It all began years ago with the introduction of stereo tape decks for your automobile, quickly progressing to the myriad of auto stereo components you see on the shelves today. Mobile lis-

deck and still come out with truly amazing sounds.

The heart of the system is the Graphic Equalizer Booster, which not only boosts RMS stereo power but allows

Assuming this system uses a total of four speakers, turning the front/rear fader control counter-clockwise brings up the level of the front speakers while lowering the level of the rear. At mid-position, both sets of speakers are at maximum level.

Depressing the power switch on the faceplate turns the device on and off,

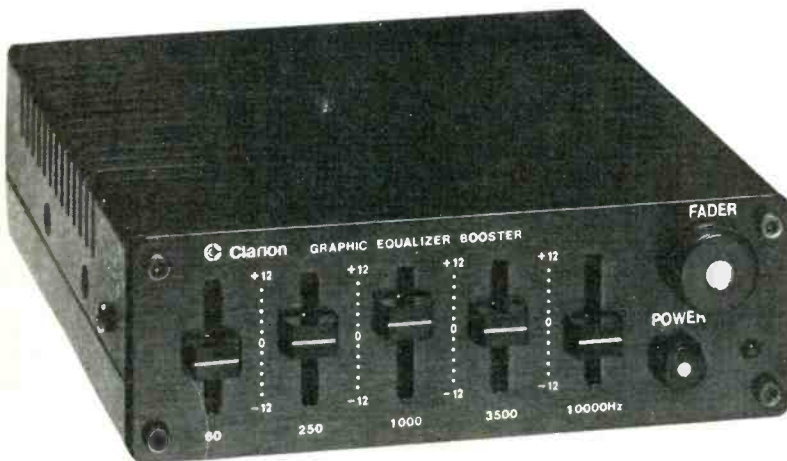

Clarion's 100-EQB-2 provides frequency control and a 30-watt (15 watts per channel) boost of RMS stereo power. Model 200-EQB offers similar controls and a 60-watt boost.

teners finally were freed from the confines of their local radio stations. What's coming next?

The latest state-of-the-art auto stereo components are not merely updated or cosmetically improved parts from the past, but sophisticated system components that enhance the clarity and quality of sound. Adding this new electronic gadgetry to your existing auto stereo system improves reproduction to the point where home stereo's inherent superiority is questionable.

Breakthrough in sound

One impressive system is Clarion Corporation's *Hi-Way Fidelity System*, which uses a matched set of components to produce the very best in auto sound. You can use Clarion's am/fm/8-track or cassette decks as a basic component or add their gear to your existing

you to individually control highs, lows, and mid-range sounds to be reproduced by your speakers. Models 200-EQB and 100-EQB-2 boost power 60 watts and 30 watts, respectively. The smaller 30-watt component in a field test did a superior job of filling the cavernous interior of a van with real-life stereo sound.

Simple operation, too

The equalizer booster has five slide controls, each affecting a different frequency band. A detent in the center position of each control locks it to the flat setting. Sliding the control knob upward boosts sound in that frequency band, while sliding it downward cuts sound in the band proportionately. The position of the slide controls shows frequency response, and the faceplate is marked to show the degree of boost or cut in dB at the center frequency.

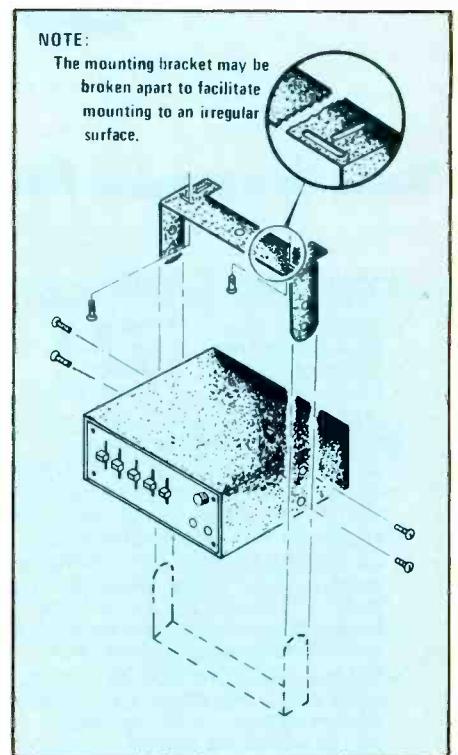

The 100 or 200-EQB units may be mounted in various locations easily with the bracket supplied by Clarion.

with a red light-emitting diode indicating on. With the button in, the unit is on and all controls may be used. With the button out, the unit is off and your speakers are re-connected to the stereo deck. This feature allows a before and after comparison that's sure to be a shocker.

Although most motorists really don't

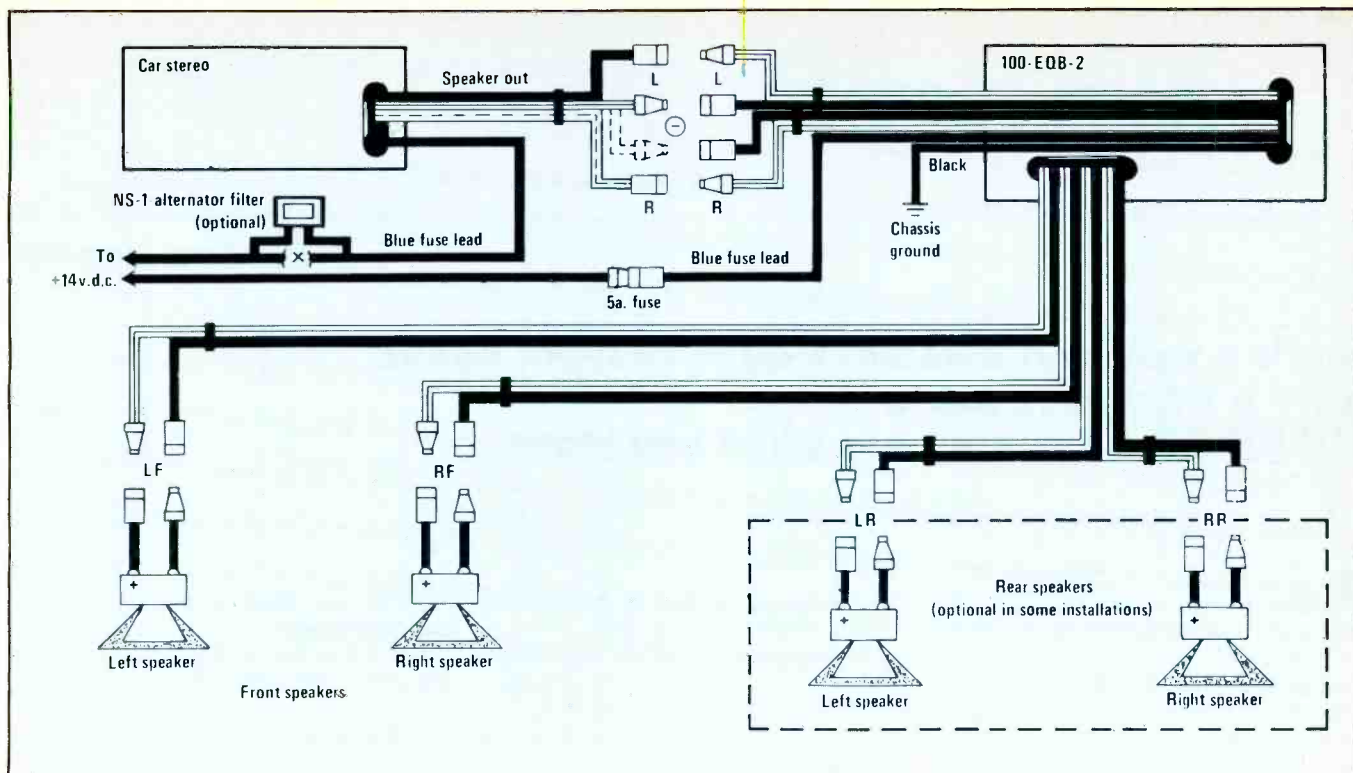

Installation is made simple with Clarion's wiring diagram and instructions that accompany either equalizer booster.

think about it, a typical car interior possesses a strange shape from a frequency point of view. It's surrounded by glass at ear level, has a carpeted floor, leather or fabric seats, and of course, a varying number of occupants. All these factors affect the frequency balance of your

of the recording or broadcast engineer—the control of frequency mix is at your fingertips.

Why control frequency response?

Also, by attenuating the bottom bass you can eliminate any rumble, while attenuating the 10,000 kHz frequency control eliminates tape hiss. If you're listening to Dolby tapes or Dolby-encoded fm in your car, this technique also will compensate for the boosted highs without cutting off much music, as would be the case with a treble control. It all adds up to the ability to *fine-tune* whatever



SK-99 speaker offers individual woofer, tweeter, and mid-range speakers behind acoustically transparent grilles.

stereo system. Until recently, there was nothing that could be done to correct this frequency imbalance; you simply lived with the best sound your conventional auto stereo system was capable of producing.

How many times have you felt a vocal was being drowned out by background instruments, or felt the number would sound better with a bit more bottom? With a graphic equalizer booster, you simply don't have to settle for the taste

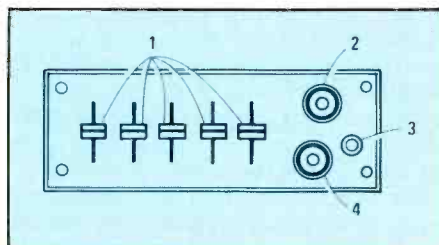

Controls on the EQB components include: 1—slide controls to allow frequency adjustments; 2—front/rear fader control; 3—on/off light-emitting diode; and 4—pushbutton power switch.

music you listen to in your car to your most exacting requirements.

In essence, equipping an automobile with this type of system will result in superb stereo sounds that will rival that of a fine home stereo system.

GILFER

"NORTH AMERICA'S SHORTWAVE MAIL ORDER PLACE"

One-Stop Armchair Shopping For All SWL Needs

* Receivers — Drake, Yaesu — special mods for better performance * Frequency Readouts * Receiving Antennas * Antenna Tuners * Frequency Calibrators * Log Books * FM or TV Guides * QSL Albums * AM Pattern Maps * ITU Publications * QSL Address Books * Confidential Frequency List * Clocks * All SWL Books

The New 1978 32nd Edition WORLD RADIO TV HANDBOOK Is Ready!

Listen to the world with this comprehensive directory of stations at your side. Best there is! Only \$11.95 ppp.

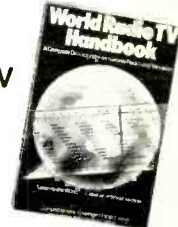

FREE SWL MINI-CATALOG GILFER SHORTWAVE

Dept. ME-5, Box 239, Park Ridge NJ 07656

CIRCLE 52 ON READER SERVICE CARD

by Judy Curtis, WB3AIQ

Here's a new and different way to prevent ripoffs: carry a CB walkie-talkie and take it out of your car when you leave.

Believe me, having your car stolen is a bummer! I stopped by a New Jersey shopping mall after work. The car was in the lot something less than the hour it took to buy a large parcel and a thunder-shower to start. I came out to an empty stall and three hours sloshing in search of the car. After adding my theft report to a thick sheaf of others, a friendly cop dropped me at a station from which I rode Conrail an hour to get home.

Thirty days later the car hadn't walked back home so insurance was forced to pay up. Getting blood from that turnip was painful but it was the personal losses which were most unpleasant. Two of my favorite pieces of electronic gear, invisible to the thief beforehand, had become icing on his cake that rainy night.

I carry two radios in the car. A two-meter ham transceiver for chatting with friends around town. And a CB to catch Smokey reports and road conditions on trips. (see *Repeaters Are The Best Thing That's Happened In Ham Radio Since Side-band*, February 1978)

With the rip-off rate what it is, I have telescoped my mobile equipment needs down to hand-held transceivers. I use the *Wilson 1405* five-watt two-meter fm handheld portable and a *Radio Shack TRC-200*. Well, actually it's a TRC-204 now. The 200 was locked in the trunk of the car when it disappeared. And the Wilson was tucked away under the front seat.

Extremely portable

The nice thing about the TRC-204 is portability. It's so small at about 10x3x2 inches that you can hide it under a seat, put it in the trunk or easily carry it away from the car to safety. It has power, antenna, microphone and loudspeaker built in. Or you can plug in a regular mobile microphone on a coil cord (Radio Shack number 21-1172; \$12). A 12-volt dc power cord (number 270-1533; \$3) runs current from your car cigarette lighter to

a connector on the side of the TRC-204 (catalog number 21-1633; \$99).

The dashboard in my car provides a small flat shelf space under the mirror. I butt the foot of the walkie-talkie against the windshield with the top of the rig pointing toward the back window. Velcro strips, available at boat-supply, hardware and other stores, hold the radio in position. I extend the built-in center-loaded antenna toward the back seat so it rests horizontally over the back of the front seat. Sure, it's horizontally polarized and the other radios on the road are hooked to vertical whips. That cuts my range, but it works! And that's what counts.

Not quite the range

If you are used to hearing signals 5-10 miles ahead and behind on Interstate highways with a vertical antenna, look for a range of only 1-5 miles with the antenna down flat.

Of course, you could hook up an external antenna as I do in the few instances when I am looking for longer CB range. The base-loaded magnetic-mount antenna (Radio Shack number 21-940; \$22) sits in the middle of the roof, feeding signals into the car via coax through a side window. You need a coax-connector adapter (number 278-208; \$1.59) to be able to plug the cable into the side of the radio.

The set runs on eight AA penlite batteries or 10 rechargeable AA-size NiCad batteries. Regular non-recharging batteries provide 1.5 volts each. Eight in series give a total of 12 volts. Rechargeables, on the other hand, put out only about 1.25 volts each so 10 are required to obtain the necessary 12 volts for circuits in the radio.

The choice between regular batteries or rechargeables boils down to cost. Radio Shack alkalines (number 23-552) are \$2.49 for a pack of four. That's \$5 to fill the radio. Rechargeables, on the other hand, are listed by Radio Shack at

\$4.19 for two. That's nearly \$21 to power the transceiver.

But, I find the regular batteries power the radio only 6-18 hours. After that, they go in the trash can for a new \$5 outlay. Rechargeables hold up only about 5-9 hours but can be revitalized easily, overnight, time and again.

Regular vs. rechargeable

Why the wide latitude in use times? It depends upon whether a lot of signals are heard on the CB channel you monitor. And whether you talk a lot, or just listen. A radio with squelch closed, receiving no signals, uses very little current from batteries. If signals are received, it takes more current from the batteries to get sound through the radio and out the loudspeaker. It takes more juice, the louder you turn up the sound. And, when you transmit, that takes far more current from the batteries than when you are only listening.

The AA rechargeables are Radio Shack number 23-125; Eveready CH-500; Ray-O-Vac 615; GE GC-1; or Mallory NC15AA. Regular non-rechargeable alkalines are Radio Shack number 23-552; Ray-O-Vac 815; Eveready E91; or Mallory MN1500.

One solution for saving batteries while driving your car is a 12-volt dc power cord. It's an eight-foot wire from cigarette lighter to radio. Batteries are switched out of the circuit when the cord is plugged into the radio.

Radio Shack's NiCad recharger (number 21-516; \$6) takes ac from your house outlet and plugs it into the side of the TRC-204. It'll bring the NiCads up to snuff overnight.

I often make a pleasure trip of 300 miles one-way (600 miles roundtrip) into Pennsylvania from New York City. Charged NiCads hold up well during the six-hour drive with some transmitting and non-stop listening. And there are plenty of drivers as well as some good buddies to eavedrop on across Interstate 80!

Vhf engineering

PRICES EFFECTIVE
JAN. 15, 1977

THE WORLD'S MOST COMPLETE LINE OF VHF-FM KITS AND EQUIPMENT

RX28C	28-35 MHz FM receiver with 2 pole 10.7 MHz crystal filter	\$ 64.95
RX28C W/T	same as above—wired & tested	117.95
RX50C Kit	30-60 MHz rcvr w/2 pole 10.7 MHz crystal filter	64.95
RX50C W/T	same as above—wired & tested	117.95
RX144C Kit	140-170 MHz rcvr w/2 pole 10.7 MHz crystal filter	74.95
RX114C W/T	same as above—wired & tested	119.95
RX220C Kit	210-240 MHz rcvr w/2 pole 10.7 MHz crystal filter	74.95
RX220C W/T	same as above—wired & tested	117.95
RX432C Kit	432 MHz rcvr w/2 pole 10.7 MHz crystal filter	84.95
RX432C W/T	same as above—wired & tested	129.95

RECEIVERS



RXCF	accessory filter for above receiver kits gives 70 dB adjacent channel rejection	8.95
RF28 Kit	10 mtr RF front end 10.7 MHz out	13.50
RF50 Kit	6 mtr RF front end 10.7 MHz out	13.50
RF144D Kit	2 mtr RF front end 10.7 MHz out	18.50
RF220D Kit	220 MHz RF front end 10.7 MHz out	18.50
RF432 Kit	432 MHz RF front end 10.7 MHz out	29.50
IF 10.7F Kit	10.7 MHz IF module includes 2 pole crystal filter	29.50
FM455 Kit	455 KHz IF stage plus FM detector	18.50
AS2 Kit	audio and squelch board	16.00

TX50	transmitter exciter, 1 watt, 6 mtr	44.95
TX50 W/T	same as above—wired & tested	64.95
TX144B Kit	transmitter exciter—1 watt—2 mtrs	34.95
TX144B W/T	same as above—wired & tested	59.95
TX220B Kit	transmitter exciter—1 watt—220 MHz	34.95

TRANSMITTERS



TX220B W/T	same as above—wired & tested	59.95
TX432B Kit	transmitter exciter 432 MHz	49.95
TX432B W/T	same as above—wired & tested	79.95
TX150 Kit	300 milliwatt, 2 mtr transmitter	24.95
TX150 W/T	same as above—wired & tested	39.95

PA2501H Kit	2 mtr power amp—kit 1w in—25w out with solid state switching, case, connectors	64.95
PA4010H Kit	2 mtr power amp—10w in—40w out—relay switching	64.95
PA50/25 Kit	6 mtr power amp, 1w in, 25w out, less case, connectors & switching	54.95
PA144/15 Kit	2 mtr power amp—1w in—15w out—less case, connectors and switching	44.95
PA144/25 Kit	same as PA144/15 kit but 25w	54.95
PA220/15 Kit	similar to PA144/15 for 220 MHz	44.95
PA432/10 Kit	power amp—similar to PA144/15 except 10w and 432 MHz	54.95
PA140/10 W/T	10w in—140w out—2 mtr amp	219.95
PA140/30 W/T	30w in—140w out—2 mtr amp	189.95

POWER AMPLIFIERS



Blue Line	RF power amp, wired & tested, emission—CW-FM-SSB/AM			
Model	BAND	Power Input	Power Output	
BLC 10/70	144 MHz	10W	70W	149.95
BLC 2/70	144 MHz	2W	70W	169.95
BLC 10/150	144 MHz	10W	150W	259.95
BLC 30/150	144 MHz	30W	150W	239.95
BLD 2/60	220 MHz	2W	60W	164.95
BLD 10/60	220 MHz	10W	60W	159.95
BLD 10/120	220 MHz	10W	120W	259.95
BLE 10/40	420 MHz	10W	40W	179.95
BLE 2/40	420 MHz	2W	40W	179.95
BLE 30/80	420 MHz	30W	80W	259.95
BLE 10/80	420 MHz	10W	80W	289.95

PS15C Kit	15 amp—12 volt regulated power supply w/case, w/fold-back current limiting and overvoltage protection	94.95
PS15C W/T	same as above—wired & tested	124.95
PS25M Kit	25 amp—12 volt regulated power supply w/case, w/fold-back current limiting and ovp, with meter	154.95
PS 25M W/T	same as above—wired & tested	179.95

POWER SUPPLIES



O.V.	adds over voltage protection to your power supplies, 15 VDC max.	12.95
PS3A Kit	12 volt—power supply regulator card with fold-back current limiting	10.95
PS3012 W/T	new commercial duty 30 amp 12 VDC regulated power supply w/case, w/fold-back current limiting and overvoltage protection	249.95

RPT50 Kit	repeater—6 meter	499.95
RPT50	repeater—6 meter, wired & tested	799.95
RPT144 Kit	repeater—2 mtr—15w—complete (less crystals)	499.95
RPT220 Kit	repeater—220 MHz—15w—complete (less crystals)	499.95
RPT432 Kit	repeater—10 watt—432 MHz (less crystals)	579.95
RPT144 W/T	repeater—15 watt—2 mtr	799.95
RPT220 W/T	repeater—15 watt—220 MHz	799.95
RPT432 W/T	repeater—10 watt—432 MHz	849.95

REPEATERS



DPLA50	6 mtr close spaced duplexer	575.95
DPLA144	2 mtr, 600 KHz spaced duplexer, wired and tuned to frequency	379.95
DPLA220	220 MHz duplexer, wired and tuned to frequency	379.95
DPLA432	rack mount duplexer	319.95
DSC-U	double shielded duplexer cables with PL259 connectors (pr.)	25.00
DSC-N	same as above with type N connectors (pr.)	25.00

TRX50 Kit	Complete 6 mtr FM transeiver kit, 20w out, 10 channel scan with case (less mike and crystals)	244.95
TRX144 Kit	same as above, but 2 mtr & 15w out	234.95
TRX220 Kit	same as above except for 220 MHz	234.95
TRX432 Kit	same as above except 10 watt and 432MHz	254.95
TRC-1	transceiver case only	29.95
TRC-2	transceiver case and accessories	49.95

TRANSCIVERS



SYN II Kit	2 mtr synthesizer, transmit offsets programmable from 100 KHz—10MHz, (Mars offsets with optional adapters)	169.95
SYN II W/T	same as above—wired & tested	239.95
SYN 220 Kit	same as SYN II Kit except 220-225 MHz	169.95
SYN 220 W/T	same as above—wired & tested	239.95

SYNTHESIZERS



OTHER PRODUCTS BY VHF ENGINEERING

CD1 Kit	10 channel receive xtal deck w/diode switching	\$ 7.95
CD2 Kit	10 channel xmit deck w/switch and trimmers	15.50
CD3 Kit	UHF version of CD1 deck, needed for 432 multi-channel operation	13.50
COR2 Kit	carrier operated relay	22.75
SC3 Kit	10 channel auto-scan adapter for RX with priority	19.95
Crystals	we stock most repeater and simplex pairs from 146.0-147.0 (each)	5.00
CWID Kit	159 bit, field programmable, code identifier with built-in squelch tail and ID timers	39.95
CWID	wired and tested, not programmed	54.95
CWID	wired and tested, programmed	59.95
MIC 1	2,000 ohm dynamic mike with P.T.L. and coil cord	12.95
TS1 W/T	tone squelch decoder	59.95
TS1 W/T	installed in repeater, including interface accessories	89.95
TD3 Kit	2 tone decoder	35.95
TD3 W/T	same as above—wired & tested	59.95
HL144 W/T	4 pole helical resonator, wired & tested, swept tuned to 144 MHz band	29.95
HL220 W/T	same as above tuned to 220 MHz band	29.95
HL432 W/T	same as above tuned to 432 MHz band	29.95



Vhf engineering

DIVISION OF BROWNIAN ELECTRONICS CORP.

BOX ME/ 320 WATER ST. / BINGHAMTON, N.Y. 13901 / Phone 607-723-9574

Prices and specifications subject to change without notice. Export prices slightly higher. 502 3100-1.78



NEW

Frequency Counter

\$79.95 kit



UTILIZES NEW MOS-LSI CIRCUITRY

You've requested it, and now it's here! The CT-50 frequency counter kit has more features than counters selling for twice the price. Measuring frequency is now as easy as pushing a button, the CT-50 will automatically place the decimal point in all modes, giving you quick, reliable readings. Want to use the CT-50 mobile? No problem, it runs equally as well on 12 V dc as it does on 110 V ac. Want super accuracy? The CT-50 uses the popular TV color burst freq. of 3.579545 MHz for time base. Tap off a color TV with our adapter and get ultra accuracy - .001 ppm! The CT-50 offers professional quality at the unheard of price of \$79.95. Order yours today!

CT-50, 60 MHz counter kit \$79.95
 CT-50 WT, 60 MHz counter, wired and tested 159.95
 CT-600, 600 MHz prescaler option for CT-50, add 29.95

SPECIFICATIONS

Sensitivity: less than 25 mv.
 Frequency range: 5 Hz to 60 MHz, typically 65 MHz
 Gate time: 1 second, 1/10 second, with automatic decimal point positioning on both direct and prescale
 Display: 8 digit red LED .4" height
 Accuracy: 10 ppm, .001 ppm with TV time base!
 Input: BNC, 1 megohm direct, 50 Ohm with prescale option
 Power: 110 V ac 5 Watts or 12 V dc @ 1 Amp
 Size: Approx. 6" x 4" x 2", high quality aluminum case

Color burst adapter for .001 ppm accuracy
 CB-1, kit \$14.95



CLOCK KIT

6 digit 12/24 hour

Want a clock that looks good enough for your living room? Forget the competitor's kludges and try one of ours! Features: jumbo .4" digits, Polaroid lens filter, extruded aluminum case available in 5 colors, quality PC boards and super instructions. All parts are included, no extras to buy. Fully guaranteed. One to two hour assembly time. Colors: silver, gold, black, bronze, blue (specify).

Clock kit, DC-5 \$22.95
 Alarm clock, DC-8, 12 hr only 24.95
 Mobile clock, DC-7 25.95
 Clock kit with 10 min ID timer, DC-10 25.95
 Assembled and tested clocks available, add \$10.00

CHEAP CLOCK KIT \$8.95

DC-4 Features: Does not include board or transformer

PC Board \$2.95
 Transformer \$1.49

600 MHz PRESCALER



Extend the range of your counter to 600 MHz. Works with all counters. Less than 150 mv sensitivity. Specify 10 or 100. Wired, tested, PS-1B \$59.95
 Kit, PS-1B \$44.95

30 watt 2 meter Power Amp

The famous RE class C power amp now available mail order! Four Watts in for 30 Watts out, 2 in for 15 out, 1 in for 8 out, incredible value, complete with all parts, instructions and details on T-R relay. Case not included.

Complete Kit, PA-1 \$22.95

CALENDAR ALARM CLOCK

Has every feature one could ever ask for. Kit includes everything except case, build it into wall, station or even car!

FEATURES:

- 6 Digits, 5" High LED
- 12/24 Hour Format
- Calendar shows mo./day
- Snooze button
- True 24 Hour Alarm
- 7001 chip does all!
- Battery back-up with built-in on chip time base

Complete Kit, less case, DC-9 \$34.95

LINEAR		REGULATOR		TRANSISTORS	
5314 Clock	\$2.95	555	\$.50	MRF-238 30W VHF	\$11.95
74S00	.35	556	.75	NPN 2N3904 type	10/\$1.00
74S112	.75	566	1.49	PNP 2N3906 type	10/\$1.00
7447	.79	567	1.49	NPN Power Tab 40W	3/\$1.00
7473	.35	1458	.50	PNP Power Tab 40W	3/\$1.00
7475	.50	LED DRIVER	7812	FET MPF 102 type	3/\$2.00
7490A	.55	75491	.50	UJT 2N2646 type	3/\$2.00
74143	3.50	75492	.50	2N3055 NPN Power	.75

DIODES: 1KV, 2.5A 5/\$1.00	100V, 1A 10/\$1.00	1N914A type 50/\$2.00
----------------------------------	--------------------------	-----------------------------

LED DISPLAYS

FND 359	.75
FND 510	1.25
DL 707	1.25
HP 7730	1.25

Red Polaroid Filter 4.25" X 1.125" \$9

741 OP-AMP SPECIAL

Factory prime mini dip with both Xerox and 741 part numbers

10 for \$2.00

SOCKETS

14 PIN	5/\$1.00
16 PIN	5/\$1.00
24 PIN	2/\$1.00
40 PIN	3/\$2.00

FERRITE BEADS

with info and specs

15/\$1.00
 6 hole Balun Beads 5/\$1.00

ramsey electronics

P.O. Box 4072 Q, Rochester, NY 14610
 (716) 271-6487

TELEPHONE ORDERS WELCOME



Satisfaction guaranteed or money refunded. C.O.D. add \$1.00. Orders under \$10.00 add \$.75. NY residents add 7% tax.

MINI-KITS

STONE DECODER KIT

A complete tone decoder on a single PC Board. Features: 400-5000 Hz adjustable frequency range, voltage regulation, 567 IC. Useful for touch-tone decoding, tone burst detection, FSK demod, signaling, and many other uses. Use 7 for 12 button touch-tone decoding. Runs on 5 to 12 volts.

Complete Kit, TD-1 \$4.95



SUPER-SNOOP AMPLIFIER

A super-sensitive amplifier which will pick up a pin drop at 15 feet! Great for monitoring baby's room or as a general purpose test amplifier. Full 2 watts of output, runs on 6 to 12 volts, uses any type of mike. Requires 8-45 ohm speaker.

Complete Kit, BN-9 \$4.95

FM WIRELESS MIKE KIT

Transmit up to 300' to any FM broadcast radio, uses any type of mike. Runs on 3 to 9 V. Type FM-2 has added super sensitive mike preamp.

FM-1 \$2.95 FM-2 \$4.95

COLOR ORGAN/MUSIC LIGHTS

See music come alive! 3 different lights flicker with music or voice. One light for lows, one for the mid-range and one for the highs. Each channel individually adjustable, and drives up to 300 watts. Great for parties, band music, nite clubs and more.

Complete Kit, ML-1 \$7.95

LED BLINKY KIT

A great attention getter which alternately flashes 2 Jumbo LEDs. Use for name badges, buttons, or warning type panel lights. Runs on 3 to 9 volts.

Complete Kit \$2.95

POWER SUPPLY KIT

Complete triple regulated power supply provides variable 15 volts at 200 mA and +5 volts at 1 Amp. 50 mv load regulation good filtering and small size. Kit less transformers. Requires 6.8 V at 1 Amp and 18 to 30 VCT.

Complete Kit, PS-3LT \$6.95



SIREN KIT

Produces upward and downward wail characteristic of police siren. 5 watts audio output, runs on 3-9 volts, uses 8-45 ohm speaker.

Complete Kit, SM-3 \$2.95

DECADE COUNTER PARTS

Includes: 7490A, 7475, 7447, LED readout, current limit resistors, and instructions on an easy to build low cost frequency counter.

Kit of parts, DCU-1 \$3.50

computers

HOW THEY WORK,

HOW YOU USE THEM, WHAT THEY CAN DO FOR YOU

BY PETE STARK

For some problems, a small analog computer can do a better job than its big, complex digital brother.

You don't hear much about analog computers these days, yet only a dozen or so years ago they were very popular. In the early 60s, when digital computers sold for \$50,000 and up, Heathkit even had a \$190 analog computer kit in their catalog. Why such a turnaround?

Interestingly enough, even today when digital computers cost just a few hundred dollars, there are still some

as in 100100000010001010001. Each of these bits is handled separately from all the others. When all the bits of a given number are handled at the same time, we call that a *parallel* operation; if they are handled one after another, we call that a *serial* operation.

Modern digital computers are overwhelmingly parallel, but there are still many applications where serial opera-

long time. If parallel operations are used, we can handle a large number of bits rapidly; but we need a different wire for each bit. This increases the complexity and cost.

On the other hand, the digital computer has two advantages. If we need more accuracy, we simply add more digits to each number. If we want to store instructions to the computer or perhaps alphabetic information, we simply can code it into numbers and then treat it as if it was numerical.

Analog computers

The whole idea of an analog computer is completely different. Instead of handling numbers, an analog computer handles *quantities* which represent numbers. The most common type of analog computer represents numbers as voltages on a wire. But unlike a digital computer which may only use two levels of voltage—one to represent a binary 0 and the other to represent a 1—the analog computer permits a whole range of voltages.

Starting with an accurate 10-volt power supply, the potentiometer divides this voltage down into a smaller value whose voltage depends on the exact position of the potentiometer knob. The precise output voltage then can be measured with a digital voltmeter, and ranges from 10.0 volts at one end of the pot setting down to 0.00 volts at the other.

Problem of accuracy

If we wanted to express a range of numbers with such a voltage, we easily could do so. For example, if we were concerned with a problem whose inputs ranged from 0 to 100, then a voltage of 10.0 volts could correspond with a value of 100, a voltage of 6.300 volts with a value of 63, and so on.

In this way, the voltage becomes an *analog* of the actual number we want to work with. In actual problems, voltages may represent quantities such as distances, speeds, etc. The voltage is an analog.

There are limitations to this, of

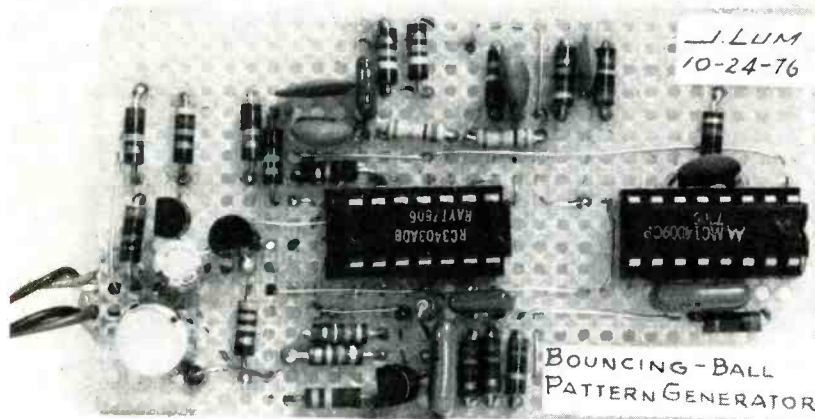

This simple analog computer built by Prof. Jackson Lum, Queensborough Community College, New York, consists of just two integrated circuits and a handful of parts. It operates from a 9-volt battery. Analog computers easily handle complex physics problems.

problems which an analog computer can solve faster or cheaper, although maybe not as well.

Digital computers

A digital computer handles only numbers containing ones and zeroes. Specifically, these ones and zeroes are called digits, which explains the name *digital*. Only two possible digits can exist inside the computer—0 and 1—and so they are called *binary* (two-valued) digits, or shortened to *bits*.

A large number, such as a thousand, is represented by a string of bits, in this case 1111101000. Small binary numbers might take just a few bits as in 11 or 101; large numbers might require many bits

as in 100100000010001010001. Each of these bits is handled separately from all the others. When all the bits of a given number are handled at the same time, we call that a *parallel* operation; if they are handled one after another, we call that a *serial* operation.

The reason for using only binary, or two-valued, digits is that they are easily represented as electrical signals. The presence of a voltage or current can be a 1; the absence a 0. On punched paper tape or cards, a hole is a 1, the absence of a hole a 0. A light lit or switch closed can be a 1, etc. The use of these bits is convenient while also reducing the chance of errors, since the difference between a 0 and a 1 is very obvious.

To express large numbers, however, we need a large number of bits. If serial operations are used, all these bits can travel over one wire, but it may take a

Ahead of
the
pack



FOX
XK
RADAR DETECTOR

...Makes your driving safer, easier...
The FOX XK is an All New Radar Detector that makes the vision-obstructing ugly black box obsolete! Compact, easily concealed, prevents harassment and theft. The FOX XK gives you 100% detection of all radar bands up to a 2 mile range with a visual and audible warning. Placed on dash or sun visor, operated from cigarette lighter, no special wiring or mounting brackets required. 1-year factory warranty. Buy all this protection for only **\$119.00!**

Order today from
PALCO, INCORPORATED

151 Steiner Dr., Henderson, Nev. 89015

Please ship _____ Fox XK's @ \$119.00
Enclosed: Money Order Check
Charge my credit card# _____

Expires: _____ Interbank# _____

Master Charge BankAmerica
(Visa)

Add \$2.00 for handling. Nev. Residents
Sales Tax.

Name _____

Address _____

Manufactured by COMRADAR Corporation
Dayton, Ohio 45424

course, one of them being the accuracy you can achieve. Just how accurate a voltage is depends on how well the potentiometer is calibrated, how well the 10-volt power supply maintains its output voltage, and how well you can measure the voltage with the digital meter. And, if this electrical signal is sent from one place to another, it may

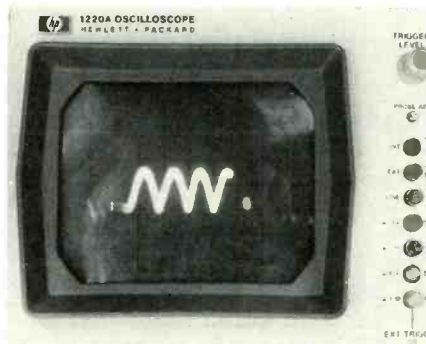

The path of a bouncing ball, calculated by a simple analog computer, appears on an oscilloscope screen. The computer draws a round circle which represents the ball. The circuit could be modified to flatten the ball as it hits the ground. A complex digital computer would be needed to draw the same picture.

not arrive with precisely the same voltage it started with; there may be some loss along the way.

Thus, an analog computer may not give as much accuracy as a digital computer—there are fundamental limits on just how accurate a number may be. Then there is another problem—a voltage can represent a number, but it cannot easily represent letters or names. So you cannot use it for the nonnumerical applications that a digital computer can be used for, such as doing a payroll or writing checks.

Good performance

On the other hand, within its limitations the analog computer really performs well. Part of this is because of its simplicity. An adder circuit, which will accept two voltages and produce a new voltage which is equal to the sum of the two inputs, can be built from three resistors and a 25 cent operational amplifier integrated circuit.

This has one startling effect. Instead of having to separate a problem into many parts and do just one at a time, as would be done by a digital computer, an analog computer can have many adders, subtractors, or multipliers operating at one time, and so it can perform many parts of the same problem all at once. Moreover, these various parts can be interconnected so that each one affects the others. This is similar to the way nature acts, and so an analog computer is very useful for solving problems from physics or engineering.

Typical problems from physics or engineering also require a mathematical operation called *integrating*. In simple

terms, this is a calculation whose result depends not only on some inputs coming in now, but also on what happened in the past.

For example, the total amount of water in a lake depends not only on how much is flowing into it now, but also on the amount of input over the last month or year. This kind of calculation involves continuous updating of a memory, which is hard to do with a digital computer at any reasonable speed. But an analog integrator can be built with one resistor, one capacitor, and an operational amplifier. The capacitor acts as a memory, since its voltage at any time depends on its history much like the voltage on an automobile battery today depends on whether the alternator was working yesterday and how long. It is a very simple circuit which can do the work of many digital circuits, and do it faster.

The conclusion is that, for certain kinds of problems, even a small analog circuit might do the job faster than a large digital computer. Moreover, its outputs—voltages—easily can be displayed on voltmeters or oscilloscopes rather than requiring expensive equipment. Since scientists and engineers feel at home with meters and scopes, this is an ideal marriage for scientific and engineering problems.

We're Fighting for Your Life

We're the American Heart Association. We're fighting the number one cause of death in this country: heart disease and stroke.

We fight with the support of 1,400 scientific investigators searching to find earlier detection and better methods of treatment and prevention. We also fight by delivering new medical knowledge to doctors and nurses for the benefit of their patients. We fight with knowledge, telling you what you need to know to stay healthy. And by sponsoring thousands of community programs from coast to coast.

When the Heart Association volunteer asks for your contribution, think of what we're fighting.

We need your help.

Please give generously to the
American Heart Association †
WE'RE FIGHTING FOR YOUR LIFE

ONCE YOU'VE GOT IT DESIGNED, YOU'VE GOT IT MADE.

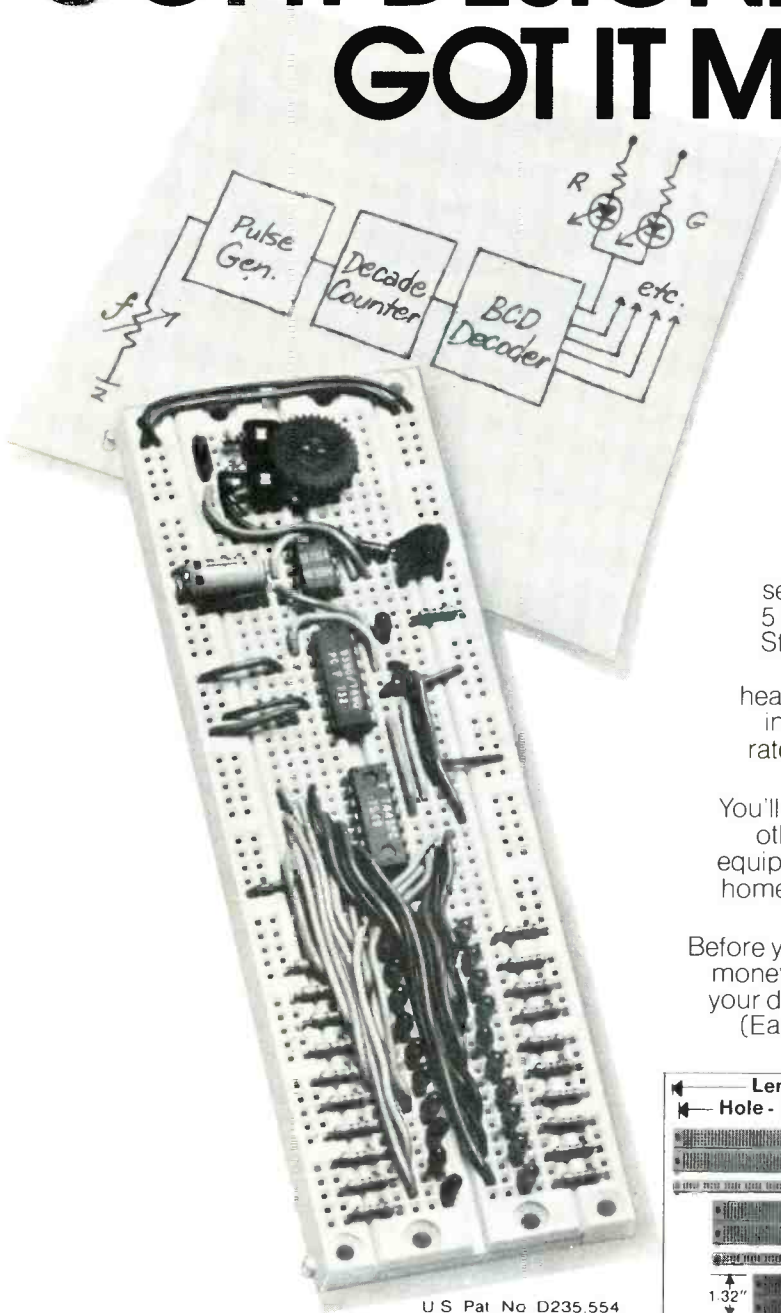

U.S. Pat. No. D235,554

It's that easy when you use CSC's QT solderless breadboarding Sockets and Bus Strips. Working directly from logic or block diagrams, you plug in IC's, transistors, resistors, capacitors, LED's — virtually any component — and optimize circuits stage-by-stage, literally as fast as you can think. (No special jumpers required, either — just ordinary #22-30 solid hookup wire.)

When you're done, you've got a highly-visible working layout that someone else can reduce to schematic, while you get other projects underway.

Available for as little as \$3.00* QT units snap together into larger breadboards, and mount securely wherever you need them. Sockets have 5 interconnecting tie points per terminal and Bus Strips feature 2 separate rows of interconnecting terminals. And all QT models are built to last: heavy-duty prestressed nickel-silver contacts, vinyl insulated backing and glass-filled plastic sockets rated at better than 100°C insure optimum day-in, day-out performance.

You'll find QT Sockets and Bus Strips useful in lots of other ways, too. Mounted on power supplies, test equipment, bench or plug in cards, they're equally at home in lab, on production lines, in QC test jigs or in the field, for on-the-spot emergencies.

Before you start your next project, start saving time and money with QT Sockets. Pick up your phone and call your dealer — or order direct by dialing 203-624-3103 (East Coast) or 415-421-8872 (West Coast). Major credit cards and purchase orders accepted.

Length Hole-to-Hole	Length	Hole-to-Hole	Terminals	Unit Price \$	
	QT-59S	6.5"	6.2"	118	12.50
	QT-59B	6.5"	6.2"	20	2.50
	QT-47S	5.3"	5.0"	94	10.00
	QT-47B	5.3"	5.0"	16	2.25
	QT-35S	4.1"	3.8"	70	8.50
	QT-35B	4.1"	3.8"	12	2.00
	QT-18S	2.4"	2.1"	36	4.75
	QT-12S	1.8"	1.5"	24	3.75
	QT-8S	1.4"	1.1"	16	3.25
	QT-7S	1.3"	1.0"	14	3.00

All QT units are .33" thick.

See your CSC dealer or call 203-624-3103 (East Coast) or 415-421-8872 (West Coast) major credit cards accepted.

*Manufacturer's suggested list Prices and specifications subject to change without notice Prices slightly higher outside USA.

CONTINENTAL SPECIALTIES CORPORATION



70 Fulton Terrace, Box 1942, New Haven, CT 06509
203-624-3103 TWX 710-465-1227
WEST COAST: 351 California St., San Francisco, CA 94104,
415-421-8872 TWX 910-372-7992
GREAT BRITAIN: CSC UK LTD
Spur Road, North Feltham Trading Estate,
Feltham, Middlesex, England.
01-890-8782 Int'l Telex: 851-881-3669

CANADA: Len Finkler Ltd., Ontario

© 1978 Continental Specialties Corporation

CIRCLE 19 ON READER SERVICE CARD

gear parts tests books



Double trouble

Bearfinder's new \$149 Two+Two radar detector is the first to use separate antennas for X and K radar bands. That may make it the most sensitive unit on the market since antennas tuned for separate bands would enhance receiver sensitivity. Bearfinder claims it gives an extra half mile warning time. You select audio or visual alert signals. It works on 12 volts by plugging into your car cigarette lighter. For more information, circle number 159 on our reader-service card.



Desktop computer

Attache is a 25-pound \$1449 desktop computer from Pertec Computer Corporation. Built around the popular 8080 integrated-circuit (IC) chip, Attache comes in a stylish cameo-white case with full ASCII keyboard including lower case and upper case letters. Its circuitry uses the popular S-100 bus with slots for 10 boards. LEDs indicate power on/off. The video output is 16 lines of 64 characters, upper and lower case, with black on white or white on black display. A 1K ram with extra sockets for PROMs is standard. Cassette memory, floppy disc and other accessories are available. For more information, circle number 163 on our reader-service card.

Find yourself

Do airplanes ever get lost? Not too often, and you won't either in your pleasure boat with the \$795 D-VOR digital very high frequency (vhf) omnidirectional rangefinder by Regency Electronics. It's a receiver to tune in coastal VOR stations and tell you which way you're headed and where you are. You triangulate between two coastal stations to determine exact position in the

same method used everyday by commercial airline pilots. It's good up to 50 miles and accurate within one degree. D-VOR is a synthesized 108-117.95 MHz receiver powered by 11-18 volts at 350 ma. The bearing indicator lights are high-intensity one-half-inch-high LEDs. For more information, please circle number 166 on our reader service card.





Computer backgammon

First it was an intelligent chess board. Now it's backgammon, the 5000-year-old game of chance. Texas Micro Games Inc. is producing the \$200 game with built-in microcomputer. In traditional backgammon, moves are determined by roll of dice. In computer backgammon, there are no dice. Moves are determined by an electronic display of simulated dice. You control the game through a computer-input keyboard. For more information, circle number 153 on our reader-service card.

Alarm computer

Casio's \$39 AQ-810 beeps when your time runs out. It combines a calculator with a clock, an alarm and an alarming timer. The calculator part is four-function with constant, four memories, square root and perfect seven-function percent key. The clock reads hours, minutes, seconds and am/pm. Two silver-oxide batteries power the AQ-810 up to 3000 hours continuous use. For more information, circle number 164 on the reader-service card.

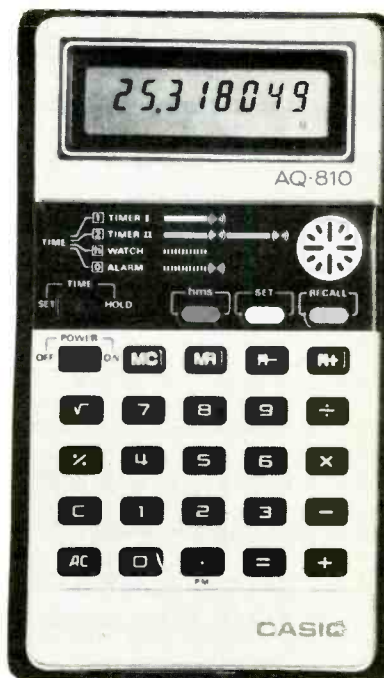

The editors roundup exciting new products you should know about.

**gear
parts
tests
books**

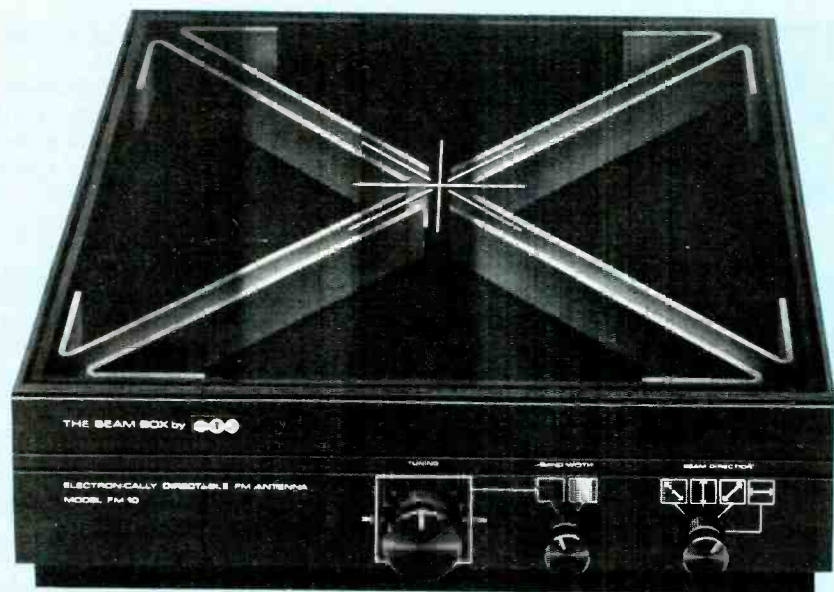

Antenna in a box

Lots of stereo fm listeners need an antenna hooked to their receivers for good reception. But it's tough to hang a wire dipole on the roof of your house. And what can you do inside an apartment building? One thing you might do is hook up British Industries Company's (BIC) \$89 Beam Box. It's a passive electronic circuit which directs its reception sensitivity to any of four geographic locations you select. The antenna does not move. It receives from all directions but is more sensitive in the direction you select. It uses no house or battery power and shouldn't be confused with so-called boosters. For more information, please circle number 152 on our reader-service card.

how it works™

ONE PIECE OF GEAR EXPLAINED

BY GERALD R. PATTON

Hold an amazing 960 steps of program in the palm of your hand with TI's super new programmable calculator.

Powerful! This is probably the best one-word description for the TI-59 programmable calculator built by the giant of the semiconductor industry, Texas Instruments.

The TI-59 is keyboard programmable, with both programs and data being recorded on and retrieved from small magnetic cards. These cards are inserted into one side of the unit until the calculator "grasps" the card. Then its tiny motor pulls it through and out the other side.

You even can protect confidential information in a program you record on a card by entering a special code. When the card is later read back into the calculator, the program can't be traced or listed, edited, or rerecorded.

The calculator's memory capacity can be allocated as needed between program steps and data registers.

It's possible to use up to 100 data registers or up to 960 program steps. Entering the desired balance of registers and program space into the calculator is known as *partitioning*.

If you really don't need the magnetic card storage capacity of the TI-59, the TI-58 provides all the other capabilities of the 59 except it has 60 data registers instead of 100 and 480 program steps instead of 960.

Go to the library

A unique feature of both the TI-59 and its smaller brother, the TI-58, is their ability to use *solid state software* in the form of a small plug-in module that fits into a compartment in the back of the unit. Several of these modules are now available, and they can be changed at any time to provide you with ready-made programs in several different fields.

The module, known as the Master Library, comes with the calculators and provides 25 programs at the touch of a key in areas such as math, statistics, finance, conversions, and games. The Master Library even contains a self-diagnosis program which tests all the module's programs.

Module programs can be used on

their own or as subroutines in other programs.

In contrast to Hewlett-Packard's Reverse Polish Notation (RPN) logic system (See *How It Works*, March 1978 p. 8), Texas Instruments uses an Algebraic Operating System (AOS) logic system. With this system, problems are entered as written, left to right.

The algebraic hierarchy in the calculator sorts and orders the entered operations. The equals key then completes all operations. Parentheses keys tell the calculator the order in which expressions are to be evaluated or the way in which numbers should be grouped as a

problem is solved. The calculator can accept as many as nine sets of parentheses open at any given time with up to eight pending operations.

ing and decrementing are processes used to set the number of times a program loop should run before going back to the main program.

Ten user flags and 72 labels are available for program use, and six levels of subroutines are possible.

Program editing is easy with keys that let you single step or backstep within a program. Insert and delete keys add or remove a step with the rest of the program moving forward or backward to accommodate the change.

Any particular program step also can be corrected or exchanged for another operation without affecting the rest of the program memory.

Programming the calculator is as simple as entering the functions that you want performed. The learn (LRN) key is pressed first to tell the calculator that a program is being entered. LRN is used again at the end of the entry to restore the normal operation mode.

Printer base

An example of a simple program given in the *TI Personal Programming manual* is used to convert Celsius (C) temperatures to Fahrenheit (F). The formula is $F = C \times 9/5 + 32$. To program the TI-58/59 for this conversion, the following keys would be used: LRN X 9 ÷ 5 + 32 = R/S LRN. All you do now is key in the Celsius value, press RST to reset the program to the beginning, and press R/S (Run/Stop) to execute the program.

As many different Celsius temperatures as you wish can be converted just by pressing the RST and R/S keys after entering the Celsius value.

Of course, the calculator can perform many scientific functions from the keyboard without even using its programming capabilities. These include: squaring, reciprocals, powers, roots, logarithms, trigonometric functions, conversions, and statistical calculations (mean, variance, standard deviation, and linear regression).

The flexibility and versatility of either the TI-58 or TI-59 can be increased by combining them with the PC-100A thermal printer. This unit provides a locking

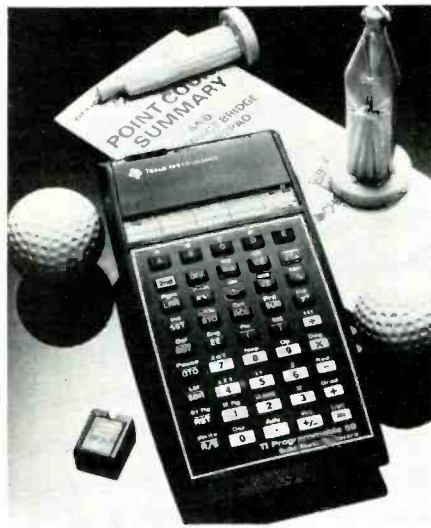

Testing, testing

Four types of number comparisons or tests can be made in a program using an independent "T" register: x equals t, x does not equal t, x larger than or equals t, and x smaller than t. The yes or no results of these comparisons are used to control the following operation in a program.

Up to 10 additional test registers are available for program looping, incrementing, and decrementing. Increment-

base for the calculator and a battery charger.

The alphanumeric printer has 64 character capability, with a maximum line length of 20 characters. It will print, on 2½-inch wide thermal paper, results and tables; messages for prompting, as part of a program, or headings; and audit trail symbols and numbers.

It will list program step numbers, key-codes, and key symbols; the contents of all data registers; and labels and locations. The whisper-quiet printer even will plot data relationships from the keyboard or directly by program.

Although this printer also operates with TI's SR-52 and SR-56 calculators, its alphanumeric, plotting, and prompting capabilities can be used only with the TI-58 and TI-59.

Small package

The rechargeable battery pack provided with the TI-59 allows about 2½ hours normal operation and can be fully recharged in four hours.

The TI-59 measures slightly under 6½ inch x 3¼ inch x 1½ inch and weighs in at only 10.74 oz. The suggested list price of the TI-59 is \$300.00 the TI-58 is \$125.00 and the PC-100A thermal printer sells for \$200.00. With these super-sophisticated TI calculators, it's never been more true that good things come in small packages!

**Great kids.
Great families.
AFS brings
you together.**



Through AFS International Scholarships, a student from abroad can live with your family for a year while attending high school in your community. Share your life and learn about the world at the same time. Write, or call (212) 661-4550.

AFS International Scholarships
313 East 43rd Street, New York, N.Y. 10017

**Do something
CREATIVE
with your musical and audio talents**

Subscribe
To
**MODERN
RECORDING**

14 Vanderverter Avenue
Port Washington, N.Y. 11050

Subscribe Now
And Receive
**THE HISTORY
OF RECORDING**
by Bob Argus **FREE**



\$22.00 for 24 issues -
Save \$14.00

\$12.00 for 12 issues -
Save \$ 6.00



check money order
enclosed for the amount of \$ _____

(Foreign subscribers add \$2.00 for each year. Foreign subscriptions payable **ONLY** in U.S. funds by international draft or money order.)

Bank Americard Master Charge

--	--	--	--	--	--	--	--	--	--	--	--

Interbank No. _____ Exp. Date _____
Mo Year

Name _____
Address _____
City _____
State _____ Zip _____

805F

5

great reasons

why YOU should

subscribe to
(if you aren't already doing so!)

CB RADIO
AMERICA'S OLDEST AND LARGEST CB MAGAZINE

S9

- 1 You'll save a bundle. Newsstand copies are \$1.50 each, or \$18 for a year's supply. Your subscription costs only \$12 – that's 33% off!
- 2 You'll get S9 earlier. Subscriber copies will reach you as much as two or three weeks ahead of newsstand or store copies.
- 3 You'll be sure of getting your copy. Many times S9 is sold out before you can find it. Your subscription is like an insurance policy of fun reading.
- 4 You'll get a bonus. Right on! A 24 page copy of the FCC Part 95 CB regulations. The Commission charges \$1.25 for a copy, and it's a must for every CBER.
- 5 You'll make our editor very happy. And there's nothing more important than having a happy Tomcat (that is, if you're going to keep a Tomcat on the premises, as we do.)

So, indulge yourself. S9 is the CB magazine that doesn't quit when it comes to giving CBers all the scoop on what's happening out in the CB world. Do it now! Today! Before you forget!! After all, spreading joy is what CB's all about, now, isn't it?

CB RADIO/S9

14 Vanderventer Avenue
Port Washington, New York 11050

Here's my \$12 for a 1 year sub,
..... \$20 for 2 years. This is a new
sub, or a renewal.

Please include my FREE copy of FCC Part 95 CB Regulations

Name _____ Call _____

Address _____

City _____ State _____ Zip _____

Signature _____



Interbank No.				Exp. Date		Mo. Year	
---------------	--	--	--	-----------	--	----------	--

BankAmericard Mastercharge

ME

Note: Allow 8 weeks for delivery of first issue.

805F

TEN-TEC CENTURY 21. The Exciting New 70-Watt, 5-Band CW Transceiver That's Surprising Everyone, Beginner and Old Timer, With Its Super Performance and Low Cost.

- Full Break-In • Full Band Coverage on 3, 5, 7, 14, 21 MHz Bands, 1 MHz on 28 MHz Band • 70 Watts Input
- Total Solid-State • Receives SSB and CW • Receiver Sensitivity 1 μ V • Instant Band Change, No Tune-up • Offset Receiver Tuning • 3-Position Selectivity • Adjustable Sidetone Level • Linear Crystal-Mixed VFO • Overload Protection • Built-In AC Power Supply • Black & Gray Styling • HWD: 6 1/8" x 12 1/2" x 12", 15 1/2 lbs. • Matching Accessories

THE RECEIVER. Double-Direct-Conversion. Easy tuning. Just select the frequency and set the audio level. Excellent cross-modulation characteristics. Offset tuning so you can tune either side of zero beat to reduce QRM. Front panel control selects one of 3 selectivity curves: 2.5 kHz for SSB reception, 1 kHz for normal CW, and 500 Hz for when the QRM gets rough. Plus separate AF and RF controls, headphone jack, and built-in speaker.

THE TRANSMITTER. Total solid-state. Push-pull Class C final amplifier. Individual low-pass filters are switched into the antenna line to reduce unwanted radiations, minimize TVI. No tune-up needed when changing frequencies or bands. And *full break-in* allows incoming signals to be heard between transmitted characters. Now CW is real conversation!

THE VFO. Common to receiver and transmitter. Permeability tuned. Linear scale. 5-5.5 MHz basic frequency is crystal-mixed to the desired frequency so bandwidth and stability are the same on all bands (crystals included for 3.5, 7, and 14 MHz bands).

THE POWER SUPPLY. Built-in, AC operated, and regulated. Monitors current demand, shuts down automatically when necessary for protection. Lighted input current meter shows proper Drive setting.

MATCHING ACCESSORIES. Model 670 Electronic Keyer, 6-50 wpm, self-completing characters, powered by the Century. Model 276 Calibrator for markers at every 100 and 25 kHz. Model 271 Crystal for 21-21.5 MHz; 272 Crystal for 28-28.5 MHz; 273 Crystal for 28.5-29 MHz.

See the surprise of the CENTURY 21 at your TEN-TEC dealer — or write for full details.

TEN-TEC, INC.
SEVIERVILLE, TENNESSEE 37862
EXPORT: 5715 LINCOLN AVE., CHICAGO, ILL. 60646

THE SURPRISE OF THE CENTURY

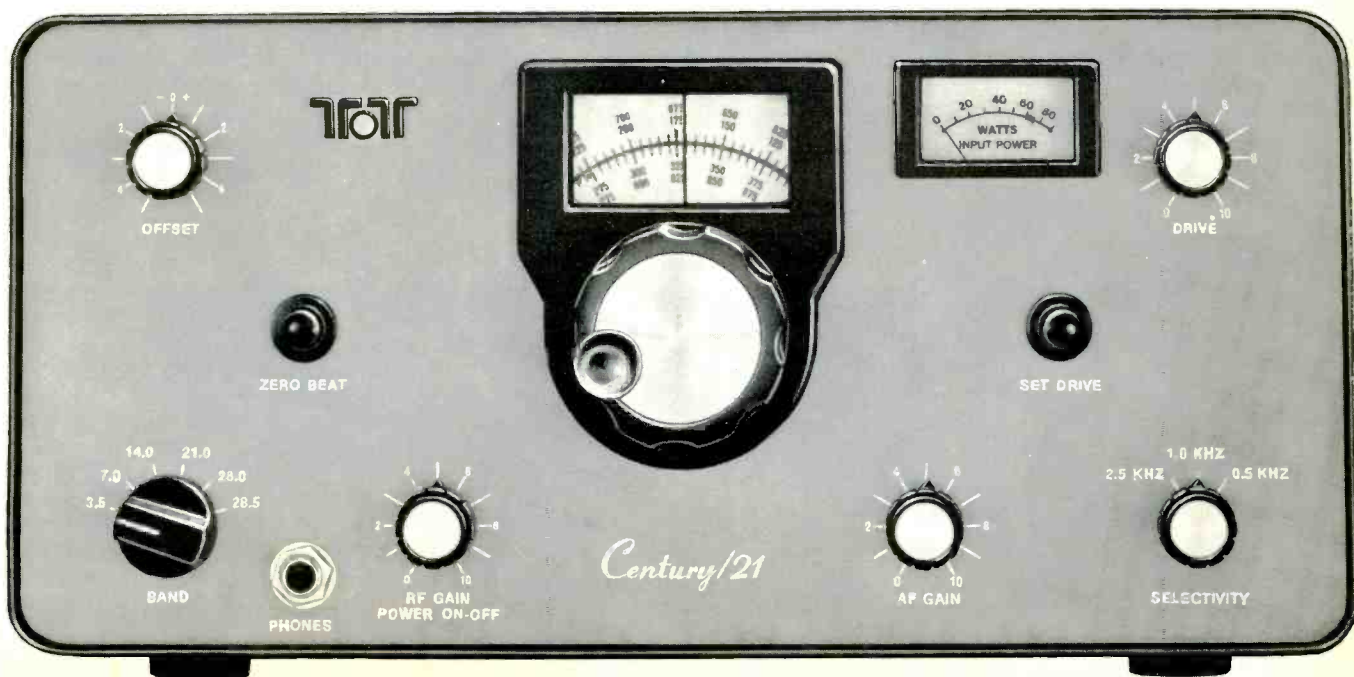

OSCAR: ham radio

Hams sent their first satellite spinning around the globe in 1961. Since then, seven more have flown. And a new generation of super-sophisticated birds is being readied for the 1980s. Here's the exciting story of how they are built and how amateur radio operators use them to talk around the world.

by Anthony R. Curtis, K3RXK
Modern Electronics Editor



Sputnik, Vanguard, Pioneer, Explorer, Apollo—20 years of space satellites in the news whetted my appetite, then bit me like a flu bug. And when OSCAR fever struck, it hit me hard.

I had dreamed of being more than a man-on-the-street in the space age. Now amateur satellites were making space communications available to everybody. Thousands of ham radio operators were chatting, handling emergencies and doing public service work through the high-flying birds. They were very excited—and I had the same gut reaction.

Take the case of Dr. Pete Peham, one of Africa's flying doctors working out of a little village on the northern slope of Mount Kilimanjaro, Kenya. Somebody gave Pete an old radiotelephone, a vacuum tube and some coaxial cable. The doctor added empty aspirin tins and a quartz crystal from his airplane radio. Right out there in the African bush he fired up a home-brew transmitter built on the aspirin tins and talked to the world through OSCAR—the Orbital Satellite Carrying Amateur Radio.

The excitement gripping Pete as he built the transmitter reached fever pitch as he sent a signal up to a satellite 900 miles overhead and heard his own call letters, 5Z4J, coming back down to his receiver. His very first chat was with another ham radio operator, through the satellite was with amateur station 4W1ED, more than 1000 land miles away in Yemen.

Since his contact with Yemen, Pete has communicated with amateur radio operators in scores of countries on several continents. Meanwhile, Suby, operator of ham station VU2UV in southern India, has been talking with hams in Finland, Rhodesia, Poland, Germany, Japan and the USSR via the satellite.

Dick Cotton, owner of station W8DX in Detroit has used OSCAR to talk with hams in 77 different countries on five continents. Ben Stevenson, W2BXA, in New Jersey, has worked amateurs in 95 nations. And Pat Gowen, G3IOF, in England, has talked to 98 countries.

Vic Politi, W1NU of Fairfield, Conn., is an amateur bulletin station, broadcasting news about OSCAR through OSCAR to anybody interested. Bud Schultz,

Radio relay in the sky

Total communications range of nearly 5000 miles is possible via OSCAR 7 as the satellite flies through overlapping range rings.

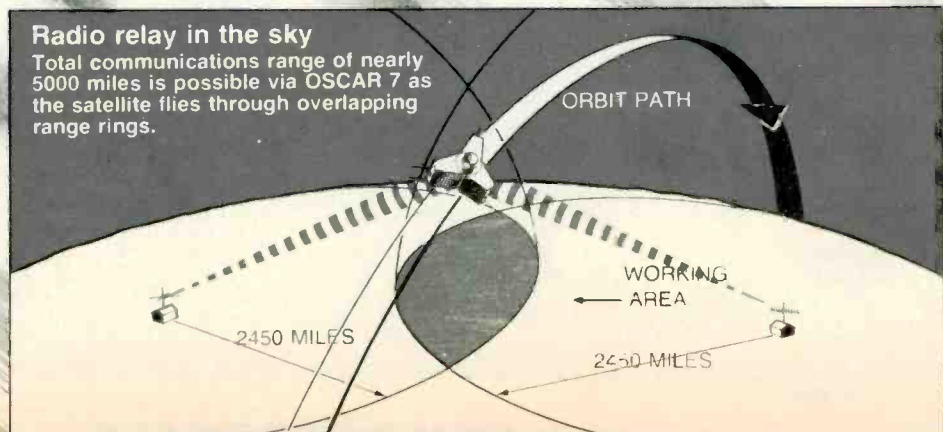

ME art: Fred Wolff

ace

OSCAR Phase III
next-generation super-sophisticated
satellite to be launched late in 1979

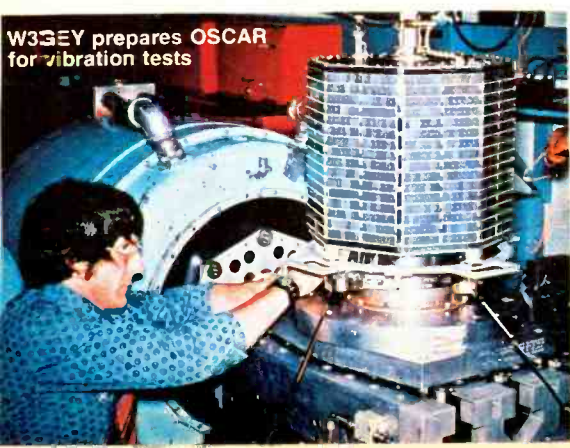

W33EY prepares OSCAR
for vibration tests





OSCAR 7 was launched Nov. 15, 1974.

OSCAR 8
latest ham bird,
just launched.

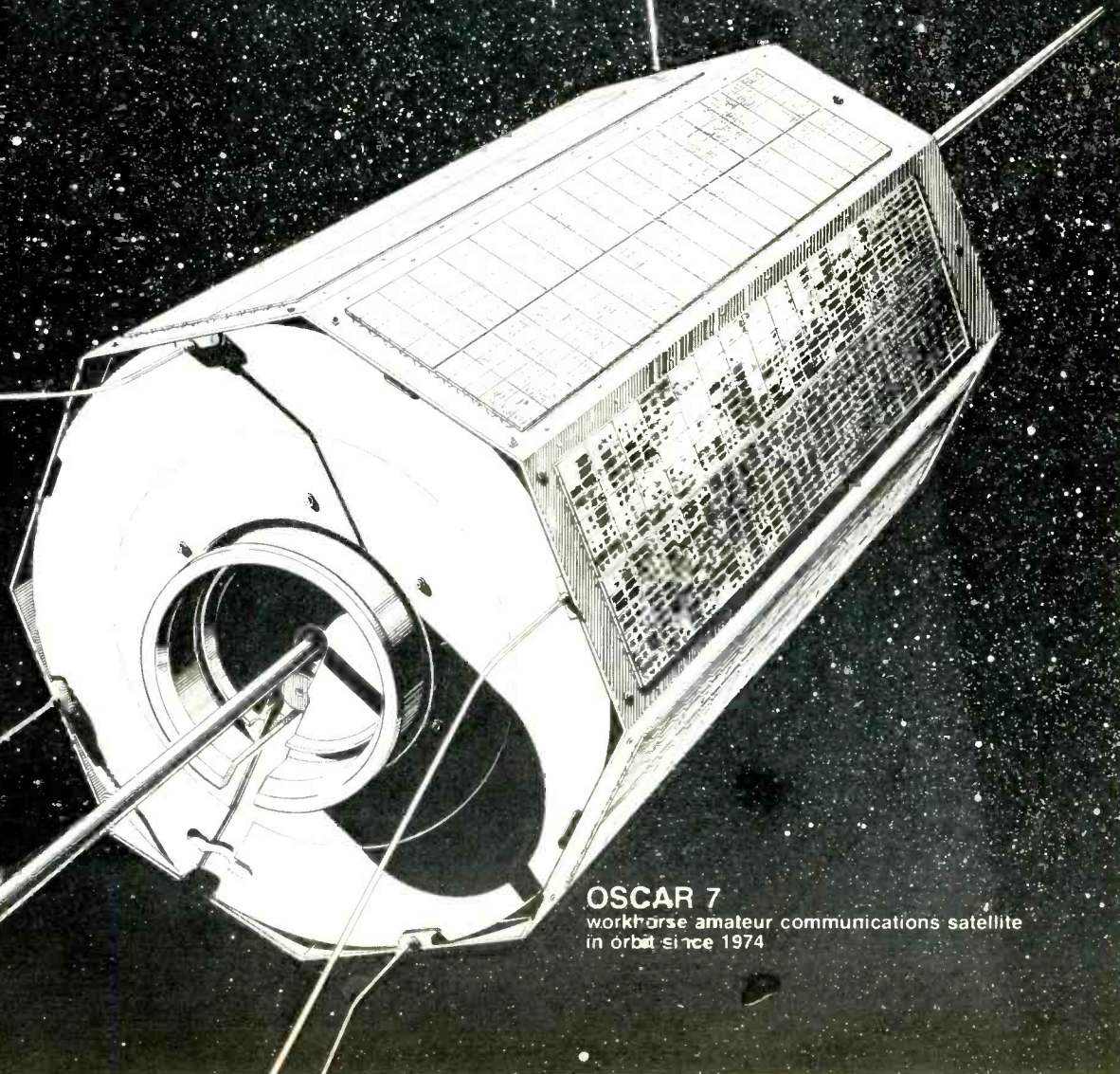
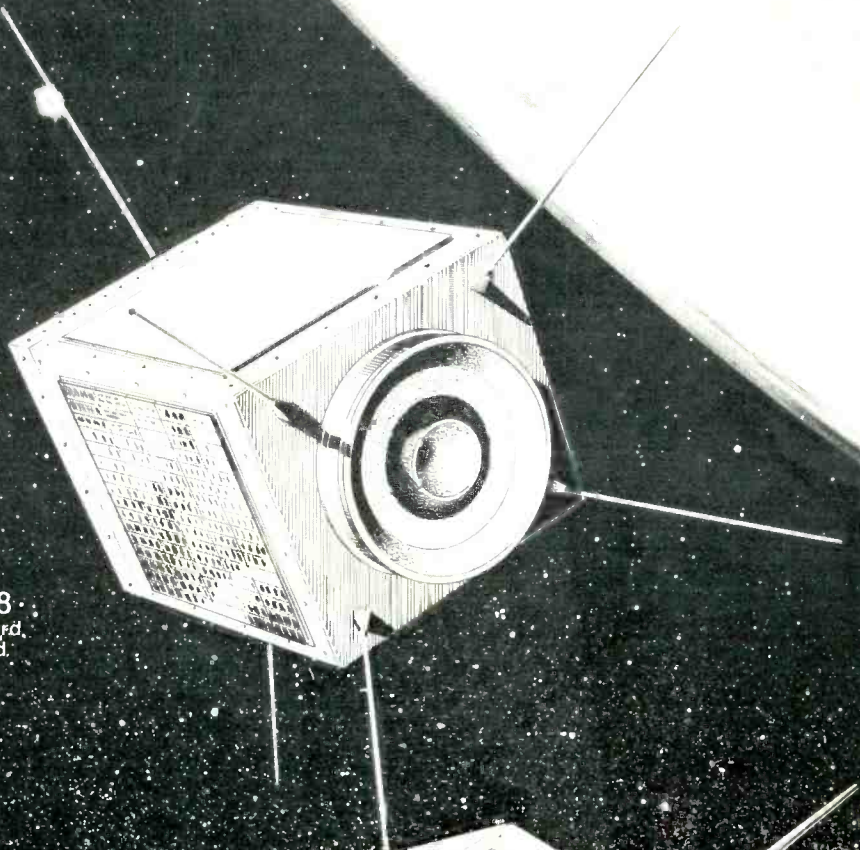

OSCAR 7
workhorse amateur communications satellite
in orbit since 1974



wiring OSCAR transmitter

W6CG of Anaheim, Calif., has earned an award for contacting other ham operators in each of the 50 states through the satellites.

Thousands are using OSCAR

OSCAR satellites are the hottest news in ham radio. The hobby, which started radio broadcasting and point-to-point communications at the turn of this century, is in the grip of OSCAR fever. Thousands of hams in nearly every nation of the world are geared up and riding along electronically every day on satellites they designed, built and financed. Many more are preparing for the ride.

There have been seven OSCAR satellites in orbit. OSCAR 8 was to have been fired into orbit in March 1978. All have gone into orbit as piggyback riders on rockets blasting government satellites into space. The National Aeronautics and Space Administration (NASA) uses OSCARs instead of deadweight ballast to further public education in space science.

OSCAR 7 is up there today, circling the globe in 900-mile-high polar orbit every couple of hours.

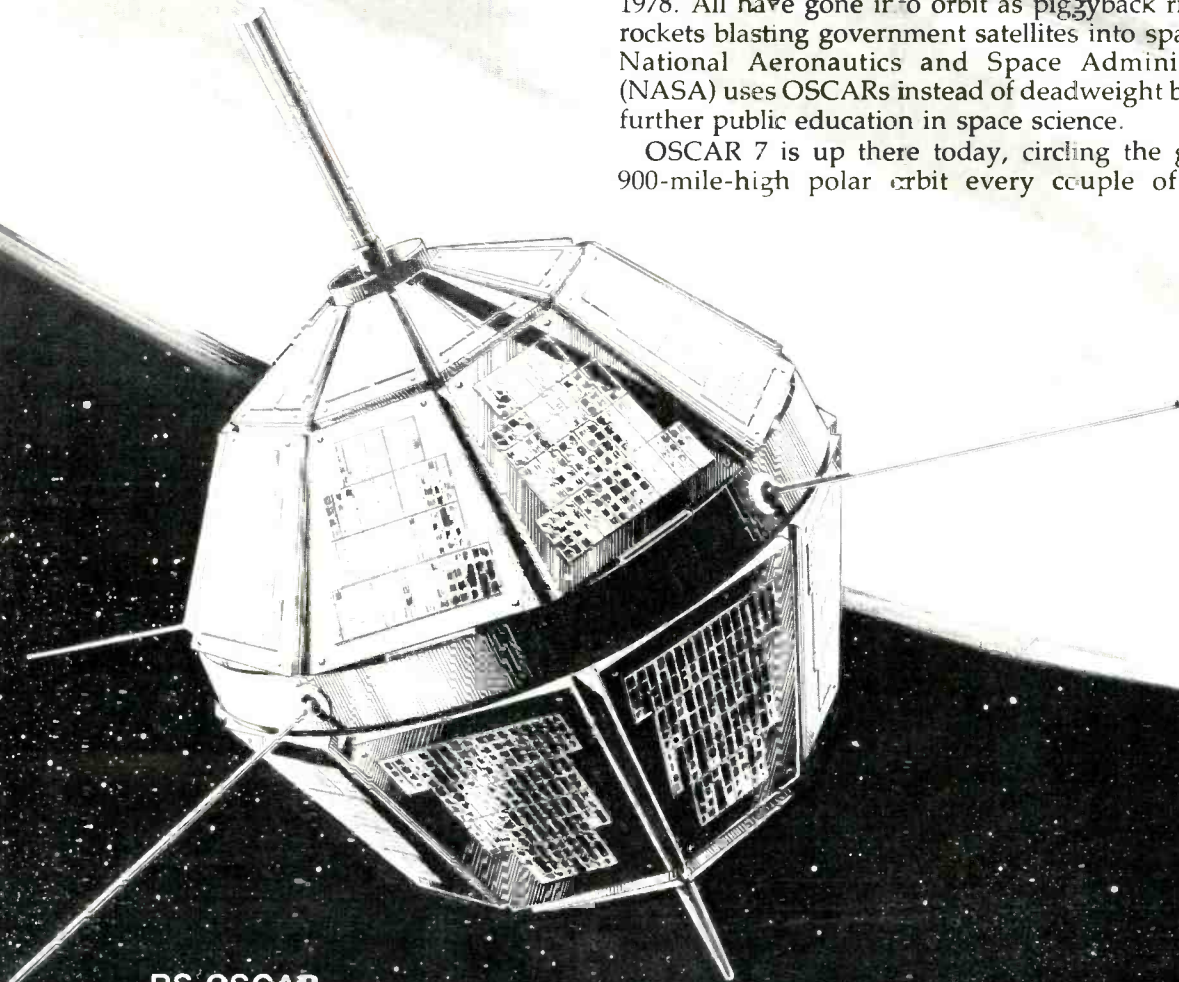

RS OSCAR
artist's concept of
Russian ham satellite
to be launched this year

OSCAR 6, which was shut down by amateur ground command for the last time only recently, was launched in 1972 alongside an ITOS weather satellite. OSCAR 7 rode aloft in 1974 with the NOAA 4 weather satellite and the Spanish INTASAT satellite. Hams use their satellites by transmitting signals up to OSCAR, which retransmits the signals over a wide area of the Earth's surface.

Satellites built by hams

OSCAR satellites have been built by hams from many countries. For instance, the 65-pound OSCAR 7 includes a telemetry system built by Australian hams, one

OSCAR 6
five years public service

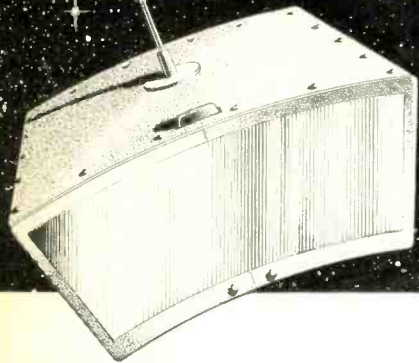

AMSAT paid tribute to the first real workhorse ham satellite when it finally was declared dead in space last year. OSCAR 6, launched Oct. 15, 1972, relayed radio signals around the world until mid-1977 when its Sun-energized NiCad batteries no longer would take a new charge. The 40-pound bird not only repeated two-way ham communications, but it also had the ability to receive and store messages for later playback. It was commanded on and off by AMSAT Earth stations. Transmitter power was one watt.

retransmitting system built by German hams, another rebroadcaster built by Americans, a beacon transmitter built by Canadian hams and another beacon built by a San Bernardino, Calif., ham club. New and even more sophisticated amateur satellites are under construction.

As I said, OSCAR fever hit me hard. When amateur satellites made space communications possible for the man-on-the-street, I had to be in on the action.

Anybody can listen

First, I wanted to hear the Morse-code telemetry beacon from the satellites. Then I wanted to be able to transmit through the satellite to other hams and shortwave listeners. I had a receiver just like any shortwave radio listener's. The set was capable of being tuned to the amateur radio 10-meter band. OSCARs transmit down to Earth on frequencies between 29.400-29.550 MHz. Most popular general-coverage shortwave radios cover 550 KHz to 30 MHz which spans the OSCAR downlink frequencies. Anybody with one of these receivers can sit at home and listen to OSCAR.

Amateur radio operators transmit up to OSCAR on frequencies in the two-meter ham band. OSCAR repeats what it hears by retransmitting down in the 10-meter ham band. It is only necessary to listen in on 10 meters to hear everything going through OSCAR. Signals passing through OSCAR are in voice and in International Morse code. Many conversations go on at the same time.

Since the satellites are at altitudes up to 900 miles, an Earth station can be as much as 2450 miles away from an OSCAR and receive signals from it when it comes over the horizon. Communication is possible with another ham up to 4900 miles away when the satellite is in view of his station at the same time.

The satellite is constantly moving along its orbital path so stations in different parts of the world come in and go out of view of the satellite. A very large portion of the globe is available for communication for the ham operator who waits for OSCAR to be in just the right spot. It's amazing too that this coverage is possible with rigs that are small in size, power and cost.

Simple antennas

Fancy equipment is not needed to hear OSCAR. All I used was the shortwave receiver and a wire antenna strung between two chimneys on my house. My antenna is a simple dipole (see *How To Build Your Own Dipole Antenna*, page 71, February 1978) constructed

with 8 feet of wire attached to each end of a center insulator. The lead-ins attaches to each "branch" at the center insulator.

Bob Peters, operator of a amateur radio station K3EZS in State College, Pa., has listened to OSCAR with a 25-year-old shortwave radio and a single long-wire antenna running from his ham shack out to a tree.

Once in a while a radio will sound dead on 10 meters and need some extra pep. To give their radios a boost, hams add small *preamplifiers* between antenna and receiver. They are available from radio stores in kits for \$6 or ready-made for \$12. Adding such a preamp would give a basic OSCAR Earth-station Cadillac quality. But, a preamp usually is not needed to hear the stronger signals passing through OSCAR.

One feature needed in the receiver is a "BFO" (beat frequency oscillator) or other means of detecting single sideband (SSB) voice communications and the beep-beep of International Morse code. OSCAR can hear and retransmit AM, FM, SSB and code. But AM and FM transmissions suck too much current from OSCAR's batteries. So SSB and code are the hams' favorite modes of operation. If you're clever with electronics, you might even retune an SSB CB radio's receiver from its present coverage of 26.9-27.4 MHz up to 29.4-29.55 MHz and be able to eavesdrop on hams talking through an OSCAR satellite.

Here comes OSCAR

It was exciting when I first fired up my own Earth station. The 10-meter band was silent as the satellite crossed the equator and moved north toward the United States. Suddenly, as the satellite came over the horizon some 2450 miles southwest of my station, the band came alive with signals. There was the Morse-code telemetry beacon on 29.502 MHz. Morse code and SSB voice conversations were everywhere between 29.400-29.500 MHz. OSCAR 7 was out over the Rocky Mountains streaking north at four miles per second.

I knew my signal should be heard in the area of 29.480 MHz so I tuned there and transmitted a long string of "dits," the letter "E" in the dit-dah of International Morse code. And there it was. My own dits coming back to me from 900 miles above the Rocky Mountains. Quickly I sent a simple "CQ de K3RXK," meaning, "Hey, you guys, how about somebody talking to me." Immediately Gordy Wightman, operator of ham station VE5XU who had been listening by coincidence on my

frequency, came right back to me, "K3RXX de VE5XU." I got goose-bumps from the excitement.

Here I was. A licensed ham for 25 years. Twenty years after Sputnik. I was freely using an orbiting satellite floating across the sky out west more than 1000 miles from my central Pennsylvania home, working another fellow all the way up in Regina, Saskatchewan, Canada!

Gordy and I talked for about five minutes, exchanging signal reports while the satellite raced 1200 miles farther north. OSCAR 7 was in view of my Earth station only 20 minutes on that pass. Listening for the satellite and for my own signals, and talking to Gordy, I used up the time.

Next evening, OSCAR 7 came over again and Ed Bizub, WA2CBB of Clark, N.J., came back to my call.

And yet another thrill was coming. My first DX distant contact came on the third night. OSCAR 7 was over the North Atlantic when G3IOR in Norfolk, England, came back to my CQ. Again the rush of excitement was overwhelming.

My first use of OSCAR 6 came shortly after I talked with G3IOR. OSCARs 6 and 7 are in similar orbits, one trailing the other. OSCAR 8's slightly lower altitude brings it around the globe a bit quicker each hour. After a satellite crosses the equator, it passes over the United States from south to north.

The Earth is moving under the satellite so OSCAR seems to be moving to the west. If the satellite comes up over the Southeastern United States one hour, it will come northward over the Rocky Mountains two hours later. And two hours after that it will come north over the Pacific Coast. And so on, around the Earth in a corkscrew pattern, daily covering the United States and the world.

Because of the spinning Earth, a satellite half the time ends up looping across the equator south-to-north on the far side of the globe. When this happens, OSCAR comes up over top of the North Pole and down over the United States from north to south. A new orbit starts whenever and wherever OSCAR passes across the equator south-to-north.

Talk to each other

Since OSCARs 6 and 7 are in slightly different orbits, they are not overhead at the same time. A half-hour after I chatted with G3IOR in England, OSCAR 6 came over my horizon. My first contact through that satellite

was with Dick Smith, W1FTX of Winsted, Conn.

Contacts through both satellites in the weeks following were with amateurs in California, Florida, Illinois, Kansas, Maine, Maryland, Massachusetts, Michigan, New Hampshire, New York, Ohio, Pennsylvania, Tennessee, Texas, Virginia, Wisconsin and Washington. Hams are on in all states and everybody has an equal chance to hear the satellite.

Telemetry beacons from the satellites are strings of numbers of Morse code that can be deciphered easily to find out temperatures, voltages and current drain in the satellites. OSCAR has an alarm clock on board to remind when internal housekeeping chores are to be done. It's easy to find out what time OSCAR thinks it is from the telemetry.

The satellites are being tested in several serious experiments. Medical electrocardiograms (EKGs) have been sent via OSCAR 7 from George Dillon, W6ELT at Santa Ana, Calif., to Len Aberbach, K3ATA, at the National Institutes of Health in Washington, D.C.

Miami hams maintain a hurricane watch and weather bulletins are transmitted via satellites. Techniques have been worked out to use the satellites to find downed aircraft. Portable Earth stations in suitcases have been built to provide emergency communications at earthquake and other natural-disaster sites on short notice anywhere on the globe.

The American Radio Relay League (ARRL), national organization of radio amateurs, makes available free to interested teachers a curriculum book for classroom use of OSCAR in teaching math, physics, astronomy, communications, electronics and space science. The book explains in elementary language how to use a simple shortwave receiver to teach and learn what keeps a satellite up, what governs its speed and how to use OSCAR for many math and science classroom activities. Hundreds of school students already have participated in the program.

Students using the educational package learn how to determine the satellite's period, how long it takes to go once around the globe; its increment, how many degrees farther west it will be when it crosses the equator next time; and its inclination, the angle at which the satellite path crosses the equator.

OSCAR 6 has a period of 114.99449 minutes, an increment of 28.7486° per orbit, and an inclination of 101.6015°. OSCAR 7 has a period of 114.94478 minutes,

please turn to page 75

OSCAR HISTORY

Amateur radio will mark its 17th anniversary in space this year. It was 12:42 p.m. on Dec. 12, 1961, when a Thor-Agena rocket lifted on a pillar of flame from Vandenberg, Calif., carrying a 10-pound OSCAR satellite aboard as ballast.

Working evenings, weekends and during every spare moment in basements, garages and attics, hams have built seven OSCARs. Here's a rundown:

OSCAR 1 carried a transmitter with power of only one-tenth of a watt which transmitted telemetry in a beacon to Earth for three weeks.

OSCAR 2, launched June 2, 1962, was identical to OSCAR 1 with telemetry-beacon transmissions lasting 18 days.

OSCAR 3, launched March 9, 1965, was amateur radio's first active communications satellite. It received ham signals and retransmitted them at the high output power of one watt. It made history as the first free-access communications satellite. One hundred different amateur stations in 16 countries communicated through the satellite during its two-week life.

OSCAR 4, launched Dec. 21, 1965, was an active satellite with three watts output. It did not make a good orbit, but hams did communicate through it, including the first direct U.S.-to-U.S.S.R. contact via satellite.

OSCAR 5, launched Jan. 23, 1970, was built by students at Melbourne University, Australia, and launched from the

United States under auspices of AMSAT. Its batteries lasted 1½ months.

OSCAR 6, launched Oct. 15, 1972, lasted five years as an active repeater satellite. It heard ham signals and retransmitted them. The 40-pound satellite could store messages and repeat them. It could be turned on or off by ground command. Transmitter power was one watt.

OSCAR 7, launched Nov. 15, 1974, was built by hams in Germany, Canada, Australia and the United States. It has two separate communications repeaters on board with two watts power. It can store messages for later replay, be turned on or off at ground command. Medical data, weather bulletins and other emergency communications have been transmitted through the 65-pound OSCAR 7.

“If you’re going to learn electronics, you might as well learn it right!”



*“Don’t settle for less.
Especially when it comes
to career training...because
everything else in your life
may depend on it. That’s
why you ought to pick CIE!”*

You've probably seen advertisements from other electronics schools. Maybe you think they're all the same. They're not!

CIE is the largest independent home study school in the world that specializes exclusively in electronics.

Meet the Electronics Specialists.

When you pick an electronics school, you're getting ready to invest some time and money. And your whole future depends on the education you get in return.

That's why it makes so much sense to go with number one... with the specialists... with CIE!

There's no such thing as bargain education.

If you talked with some of our graduates, chances are you'd find a lot of them shopped around for their training. Not for the lowest priced but for the best. They pretty much knew what was available when they picked CIE as number one.

We don't promise you the moon. We do promise you a proven way to build valuable career skills. The CIE faculty and staff are dedicated to that. When you graduate, your diploma shows employers you know what you're about. Today, it's pretty hard to put a price on that.

Because we're specialists, we have to stay ahead.

At CIE, we've got a position of leadership to maintain. Here are some of the ways we hang onto it...

Our step-by-step learning includes "hands-on" training.

At CIE, we believe theory is important. And our famous Auto-Programmed® Lessons teach you the principles in logical steps.

But professionals need more than theory. That's why some of our courses train you to use tools of the trade like a 5 MHz triggered-sweep, solid-state oscilloscope you build yourself—and use to practice troubleshooting. Or a beauty of a 19-inch diagonal Zenith solid-state color TV you use to perform actual service operations.

Our specialists offer you personal attention.

Sometimes, you may even have a question about a specific lesson. Fine. Write it down and mail it in. Our experts will answer you promptly in writing. You may even get the specialized knowledge of all the CIE specialists. And the answer you get becomes a part of your permanent reference file. You may find this even better than having a classroom teacher.

Pick the pace that's right for you.

CIE understands people need to learn at their own pace. There's no pressure to keep up... no slow learners hold you back. If you're a beginner, you start with the basics. If you already know some electronics, you move ahead to your own level.

Enjoy the promptness of CIE's "same day" grading cycle.

When we receive your lesson before noon Monday through Saturday, we grade it and mail it back—the same day. You find out quickly how well you're doing!

CIE can prepare you for your FCC License.

For some electronics jobs, you must have your FCC License. For others, employers often consider it a mark in your favor. Either way, it's government-certified proof of your specific knowledge and skills!

More than half of CIE's courses prepare you to pass the government-administered exam. In continuing surveys, nearly 4 out of 5 CIE graduates who take the exam get their Licenses!

For professionals only.

CIE training is not for the hobbyist. It's for people who are willing to roll up their sleeves and go to work... to build a career. The work can be hard, sure. But the benefits are worth it.

Send for more details and a FREE school catalog.

Mail the card today. If it's gone, cut out and mail the coupon. You'll get a FREE school catalog plus complete information on independent home study. For your convenience, we'll try to have a CIE representative contact you to answer any questions you may have.

Mail the card or the coupon or write CIE (mentioning name and date of this magazine) at: 1776 East 17th Street, Cleveland, Ohio 44114.



Patterns shown on TV and oscilloscope screens are simulated.

CIE Cleveland Institute of Electronics, Inc.
1776 East 17th Street, Cleveland, Ohio 44114
Accredited Member National Home Study Council

YES... I want the best of everything! Send me my FREE CIE school catalog—including details about troubleshooting courses—plus my FREE package of home study information. MO-05

Print Name _____

Address _____ Apt. _____

City _____

State _____ Zip _____

Age _____ Phone (area code) _____

Check box for G. I. Bill information: Veteran Active Duty

MAIL TODAY!

LEDs, digital logic: the world of electronics takes to the highways

Flashy digital add-ons dazzle and inform drivers at the same time. Easy to install and fun to use, these instruments will spruce up your driving.

by Ron Cogan
Contributing Editor



With the technological innovations and luxurious appointments built into today's cars, what could be new? Digital electronics, that's what. The flashing, impressive LED and LCD displays we've all come to know and love on our wrist watches, alarm clocks, microwave ovens, and calculators have been slowly making their way into the automotive scene.

The first inroads were made with simple digital clocks sporting bright red LED readouts which quickly were followed by instruments of every sort imaginable. Installations are simple, involving only mounting the device with brackets provided and splicing in a few power wires. Because they're so easy and fun, digital instruments can be in anyone's car whether the motorist possesses an expertise in electronics or not.

What's available

What types of instruments are available? Anything from mini-computers to complete engine instrumentation—and everything in between. Devices that will tell the time

of day, the fuel economy you are attaining, the distance you've traveled on a trip, and more.

Into the automotive rally scene? There are even a few rally computers available which will, on command, indicate the speed you've averaged on a course and allow elapsed time computations at your fingertips. Some of the digital clocks on the market not only tell you the time of day, but can be programmed to wake you up with a beep-tone when camping.

Obviously, this can be taken as a sign of things to come in the automotive market. Although devices such as these are primarily available from *aftermarket* manufacturers (not from car manufacturers directly), Detroit is working on it feverishly. As an example, Cadillac Motor Division is expected to emerge with a very sophisticated mini-computer system with LED displays at any time now. We can safely assume, then, that other car manufacturers are right on Cadillac's heels with prototypes or designs of a similar nature. We'll certainly all be waiting to see them.



One of the flashiest digital instruments for automobiles out is this setup from RLS Industries. The digital tachometer, which reads in 50 rpm increments on an adjustable LED display, is either sold

separately, top above, or as an integral part of a sophisticated dash setup, bottom above. RLS Industries, 799 E. 7th St., Upland, CA 91786.

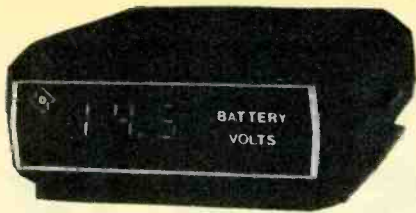

Monitoring basic engine functions can be done in style with these goodies from Instrumentation Diversified Inc (IDI). Instruments in this series include water temperature, oil pressure, voltage, fuel level, speedometer, and tach. IDI Automotive Division, 14757 Manning Trail N., Stillwater, MN 55082.



Another useful product for campers is this Digitar inside/outside thermometer which reads in Fahrenheit or Celsius. Interior and exterior sending units are supplied and installation is simple. Magnaphase Industries, 26207 Maple Valley Hwy., Maple Valley, WA 98038.



Installation is simple with this small, stick-on LED clock, above. Its real advantage is exceptionally small size and ability to install the clock just about anywhere. If you're into liquid crystal display, Applied Marketing also offers this self-stick model, above right. The clock is powered by an internal battery and can be adhered to dash or an optional clear plastic stand. Applied Marketing Corp., 864 Phoenix Dr., Ann Arbor, MI 48104. The Digital alarm clock offers a large one-half inch LED readout and can be dash-mounted in your vehicle to appear factory installed. Features quartz accuracy, alarm function, hour and minute set, and more. This device is especially handy in motorhomes, vans, trucks, and trailers where an efficient alarm would prove useful. Magnaphase Industries, 26207 Maple Valley Hwy., Maple Valley, WA 98038.



With citizen band radios offering better and more unique features as time passes, it was only a matter of time before digital displays showed up on the scene. Clarion Mike CB system is one of the handsome models using digital readouts. Clarion Corp., 5500 Rosecrans Ave., Lawndale, CA 90260.



Another device for gas-conscious motorists is the Fuelmaster, which indicates your miles-per-gallon or miles-per-hours as needed. Smallish case fits easily under dashboard. Fueltronics, 4029 Westerly Place, Suite 202, Newport Beach, CA 92660.

Home remedies for tv

Here are the official tricks from the Federal Communications Commission you can use to clear away CB and ham transmitter interference from tv, fm and stereo.

During the past few years tremendous advances have been made in the field of radio and television communications. Communications by radio and television from any point on the earth, and sometimes from points beyond the earth, have now become commonplace.

In recent years, the growth of two-way radio, permitting personal communications from motor vehicles and homes, has been explosive. These

advances in communication technology are not without problems.

The radio frequency *spectrum* is becoming crowded and interference problems, due to lack of compatibility between the different radio systems, are becoming widespread. This is evidenced by the thousands of complaints of interference to home electronic entertainment equipment (television, stereo, electronic organ, telephone, tape recorder and other audio equipment)

received by the Federal Communications Commission (FCC) each year.

Most of these interference problems can be traced to one or more of the following factors:

■ Characteristics of the receiving system, such as the system design and installation.

■ Environment of the receiving system, including the distance from television transmitter, intervening terrain, or the presence of nearby radio transmitter.



Electrical interference—This is what your television picture looks like when your set is reacting to any of the following devices operated in or near your home: Hair dryers, electric shavers, mixers, blenders, power saws, vehicle ignition systems, and other similar devices. When this type of interference is occurring, you may also hear a sizzling or buzzing sound along with the sound of the tv program. Do not confuse this interference with poor tv signal.



Poor tv signal—This is the type of television picture you will be receiving if you are far away from the tv transmitter site or if there is a building or mountain between you and the tv station. Defective antenna, improper antenna orientation, or disconnected or broken lead-in wire may also cause this problem. The sound of your tv usually will not be affected unless the tv signal is extremely weak. You can improve the quality of the signal by installing a higher antenna, using a directional antenna, a signal amplifier, or repairing the lead-in wire. Check with your tv sales and service representative on antenna systems available.

interference



■ Characteristics of radio frequency generating devices, such as citizens band (CB) and other radio transmitters.

■ Practices of the radio transmitter operator. For example, a CB user operating an illegal overpower transmitter or amplifier.

The FCC has jurisdiction over some of these factors. For example, the Commission has technical standards for transmitting devices such as CB trans-

mitters. These technical standards were recently strengthened by the the Commission. In addition, the Commission has rules concerning the way in which radio transmitters may be operated.

Obviously, control of some of the factors is not within the jurisdiction of the Commission. The quality of the television signal received at your home, for example, is most often influenced by the distance you live from the television station and the intervening terrain.

The commission has no standards for the design and installation of television receivers and associated antenna systems. However, many interference problems can be corrected by modifying and improving the television receiving systems.

As you begin to identify the type of interference you are experiencing, keep in mind that not only must your equipment be able to receive and amplify the desired signal, but it also must reject all

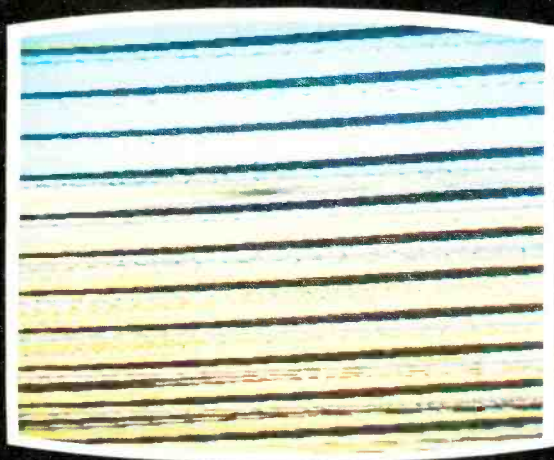

Horizontal control problem—When your set requires adjustment of the horizontal hold control or replacement of a bad tube or component, the above pattern will appear on your tv picture. The sound, if affected, may contain a high pitch tone. To eliminate, simply adjust your horizontal hold control or call your service representative to replace the bad tube or component.

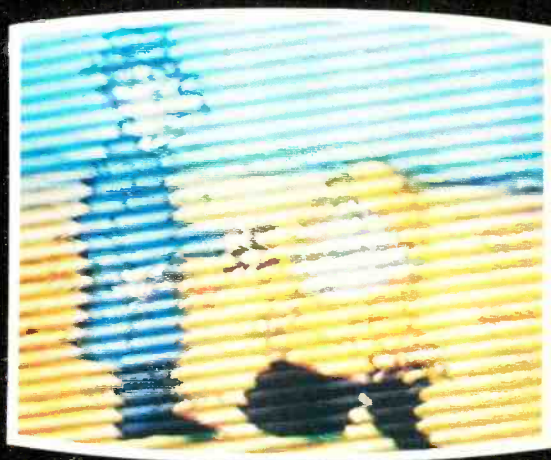

Radio transmitter interference—This is what your picture looks like when it is picking up the transmission of CB, Amateur, Police or other radio transmitters. It will normally affect vhf channels only. You may notice that the interference pattern changes or moves as the radio transmitter operator talks. Do not confuse this interference with horizontal control problem.



unwanted signals and noise. This means that, even if the equipment you think is causing the interference is being properly operated, it is still possible to experience interference.

Purchasing a filter

There are no set procedures for eliminating television interference—it's a matter of eliminating the most likely sources of interference a step at a time. The first step is to install an inexpensive *high-pass filter* on the back of your tv set. In making this installation, follow these procedures:

- Determine the type of antenna wire that is connected to your tv set. Coaxial cable is a round lead-in wire which requires a filter impedance of 75 ohms. Twin lead is a flat wire which requires a filter impedance of 300 ohms.

- Purchase the filter which matches the type of antenna wire going to your tv set. The impedance information mentioned above will be on the filter label. Do not use a combination of twin-lead and coaxial cable without proper matching transformers, often called baluns. Filters are available in most stores that sell or repair television sets, and in electronics stores such as Radio Shack and Lafayette.

- Carefully read the instructions that are provided with the filter. You should be installing the filter on the back of your tv set, as near to the antenna terminal as possible.

- If you are on a cable system, you may still install the filter at the antenna terminal. However, if the interference continues, contact the cable company repair service for assistance. Do not attempt to modify the cable system yourself.

Installing a filter

The following is a guide to installing the filter. You may have to modify some steps to suit your particular installation.

- Disconnect the antenna wire (twin-lead or coaxial) from the television set antenna terminals.

- Connect the wire from the antenna to the input terminals of the filter.

- For twin-lead wire, connect a very

short (1" to 2") "jumper" wire from the antenna input terminals of the set to the filter. For coaxial cable, it will be necessary to obtain a jumper cable that has the proper connectors already installed. This can be purchased at the time you buy the coaxial filter.

- Be sure that in the case of twin lead wire, the actual wires are making contact with the terminals. For coaxial cable, be sure the connector plugs are properly installed on the coaxial cable.

- If you have an amplifier in your antenna system, you should have a filter installed ahead of the amplifier and another filter ahead of the tv receiver input terminals. If the amplifier is located close to the receiver, then install the filter before the amplifier only.

Booster amplifiers usually are located near the back of the tv set. Mast mounted outdoor amplifiers are usually located on the antenna. Distribution amplifiers usually are located somewhere in the distribution system. If a distribution amplifier is in your antenna system, then be sure to trace the entire length of the antenna system, because amplifiers are usually in out-of-the-way places.

- The connecting wires between the filter and amplifier, and between the amplifier and antenna terminal, should be as short as possible.



FM interference—Interference from a nearby fm broadcast station will cause this type pattern to appear on your tv screen. Although it normally will affect tv channel 6 only, one additional channel in the channel 2-13 series may occasionally be affected. It sometimes affects both the picture and sound of your set. Note that the interference pattern may change or vary with the sound of the fm broadcast station program, *not* the sound of the tv program. Do not confuse this interference with fine tuning problem.



Fine tuning problem—This is the type of pattern which will appear on your screen if the fine tuner of the tv set is not properly adjusted. Although it looks similar to fm interference, you will note that the pattern changes with the sound of the tv program. Readjust the fine tuning control of the tv set to eliminate the problem.

■ The instructions provided with the filter you bought may call for a ground connection. The wire should be as short as possible and connected between the high-pass filter ground terminal and a metallic cold water pipe or a ground rod. Use bell wire, which can be obtained in most variety stores, for this connection.

■ If installation of the filter at the tv antenna terminals does not entirely eliminate the interference, contact your service representative to install a high-pass filter inside the tv set at the tuner input terminals. Internal modification to your set should be done only by a service representative.

Resolution of interference

Although some interference problems can be attributed to television receiver, many problems can also be traced on CB radio transmitters. Therefore, upon receipt of an interference complaint from your neighbor, you should take all steps possible to insure that your radio transmitter is not causing the interference.

Voluntary installation of a low-pass filter, or other steps as outlined below, may eliminate the interference, and may prevent you from receiving an order from the Commission to implement these measures. You are not, however,

required to service or add filtering to the complainant's television, and should not take any such action without the full cooperation of your neighbors.

CB interference to channel 2

You are cautioned that the use of an amateur transmitter on the Citizens Band is illegal. Further, the use of external rf power amplifiers with CB transceivers is illegal. Both actions may subject you to Commission actions or criminal penalties.

Second harmonic interference from a CB transmitter to channel 2 may exist even though the transmitter meets FCC specifications for harmonic radiation. In these cases, a tuned filter across the antenna terminals of the television should help. An open circuit, quarter-wave, tuned stub across the antenna terminals can also be used. The stub should be made of the same type of wire as that connected to the antenna input terminals of the television.

The initial stub length should be 37 inches for RG-59/U coax; and 48 inches for 300 ohm twin lead. After connecting the stub, cut the unterminated end of the stub off in one-quarter inch sections until the interference is eliminated.

For harmonics falling on other tv channels, such as channel 5, 6, or 9, the

length of the stub can be calculated using the formula:

$$\text{Length in inches} = \frac{2952V}{f}$$

where V = velocity factor of line
and f = frequency in megahertz

Amateur interference to channel 2

One additional type of interference from a nearby transmitter is unique to the amateur 6 meter band—50-54 MHz. Since 6 meters is immediately adjacent to channel 2 (54-60 MHz), interference to channel 2 may occur.

In most cases, installation of an open circuit, quarterwave, tuned stub at the antenna terminals of the television set should be effective.

If RG-59/U is used as the tv lead-in wire, the initial length of the stub should be 42 inches. If 300 ohm twin lead is used, the initial length should be 53 inches.

After the stub is attached to the television, begin cutting off the unterminated end of the stub one-quarter inch at a time until the interference is eliminated. If the interference is reduced, but not eliminated by this method, add a second



Co-channel interference—This is the type of pattern which will appear on your screen when your set is simultaneously receiving two tv signals. Note that the two images are different, as though one picture has been placed on top of the other. Co-channel interference is due to either atmospheric conditions or the location of your home in relation to the location of the tv stations. If the problem is from atmospheric conditions, little can be done to correct the problem. However, the problem is usually temporary. If it is caused by the location of your home in relation to the location of the tv stations, use of a highly directional antenna may help eliminate the problem. Do not confuse this interference with ghosting.



Ghosting—This is the type of picture you will see when the tv signal is reflected, or the tv antenna or antenna lead-in wire are in poor condition. When ghosting occurs, it means the tv signal is being reflected off a mountain, building or other man-made structure, with the signals being sent over different paths to your tv set and arriving at slightly different times. With ghosting, note that the two images are the same. Rotation of your tv antenna to a new position, or installation of shielded lead-in wire may resolve this problem. If rotation of the antenna does not resolve the problem, have a service representative check the condition and/or placement of the antenna and antenna lead-in wire.



stub directly to the input terminals of the tuner.

Electrical interference is caused by either vehicle ignition systems or electrical devices. The first step in attempting to resolve electrical interference problems is to locate the source of interference.

Interference from vehicle ignition

Ignition interference sounds like a "popping" noise in the sound system of your tv that rises in intensity. This can be caused by any vehicle ignition system, including gasoline operated lawn mowers, snowmobiles, and automobiles. If the interference is to television receivers, you may hear the popping noise and also see dancing dots in the picture. In some case, you may only see the interference, and not hear the popping noise in the sound.

If your own vehicle is causing interference, you may wish to install a commercially manufactured kit in your vehicle to reduce the ignition noise. Other remedial measures include relocating your antenna, raising the antenna, and using shielded lead-in antenna wire.

Interference from electrical devices

The interference you are experiencing on your television set or am/fm radio may be caused by an electric razor, vacuum cleaner, fan, drill, electric blankets, bake ovens, fluorescent lights, arc

lights, light dimmer controls, relays, static from machinery, lightning arrestors, adding machine.

Cash register, circuit breakers, ultraviolet lamps, germicidal lamps, defective wiring, loose fuse, arc welder, switch contacts (such as on dishwashers and other home appliances), refrigerator, water pump, sewing machine, light blinkers (including Christmas tree lightblinker), electric heating pads, aquarium warmers.

Neon signs, door bell circuits/transformers, toys (such as electric trains), sign flashers, antifriction bearings, printing press static eliminators, calculator, insulators, incandescent lamp (new or old), sun lamps, electrical pole (ground wire cut or poor contact), loose electrical connection, electric fence unit, furnace controls, power company transformers, and smoke precipitators.

If you have a portable radio that is affected by the interference, use it as a detection device to assist in locating the source of interference. With the portable radio, move from room to room and determine in which room the interference appears to be the loudest. Then look for one of the devices listed above and unplug it to see if the interference disappears. If several devices are in the room, unplug them, one at a time, until the interference disappears.

If a portable radio is not affected, you can go to the main fuse or circuit breaker box in your home, remove one fuse at a time, or shut off one breaker at a time, and see if the interference goes away.

If it does not go away when the first fuse or circuit breaker is off, replace the fuse or turn the circuit breaker back on and continue on until the interference does disappear. When the circuit that supplies the power to the tv or radio is turned off, it will be necessary to plug that device into some other circuit.

When the interference disappears with a fuse removed or circuit breaker off, go to the room supplied by that cir-

cuit and look for any of the suspect devices. If any are in the room, replace the fuse or turn the circuit breaker back on. Then unplug the device suspected of causing the interference. If several devices are in the room, unplug them, one at a time.

If you are unable to locate within your own home the device that is causing the problem, the interference may be coming from a device located in your neighbor's home. With the cooperation of your neighbor, follow the same procedures described above.

If your investigation leads you to suspect that a power line or power company equipment is the source of interference, contact the power company.

To resolve electrical interference, modifications must be made to the interfering device. This should only be done by a qualified service representative. Short duration interference, such as that from electric drills and saws, may be very costly to attempt to eliminate; you may just want to "live with it".

Resolving electrical interference

Before proceeding with the following steps to modify the device located as the source of interference, you should check the local electrical codes to determine if the device may be modified, and whether a licensed electrician must modify the device.

Caution: all bypassing of devices with capacitors should be done with extreme care to insure that the capacitors do not short out the ac line. Dangerous voltages exist which can cause electrocution if mishandled. Avoid power wiring which can cause the full ac line voltage to appear on the case of the device.

Since interference from an electric drill or saw may be of short duration, we suggest no modifications be made to the device. If, however, interference is of long duration, and you wish to take on this task, proceed as follows:

- Interference from a drill or saw is actually caused by arcing between the brushes and commutator. The interference then is transmitted through the power cord. Bypassing each side of the line to ground each side to the other, and the switch with capacitors may be helpful. The bypassing should be done inside the device in question.

- Electric blankets, fish tank heaters, and other thermostatically controlled appliances, with worn and pitted contacts, cause interference because of contact arcing of the breaker points. This can be eliminated by bypassing the contacts with a .001 mfd capacitor or replacing the worn or pitted contacts.

- Defective devices such as doorbell transformers should be replaced.

- Dimmer switches that utilize an SCR or triac can produce tremendous interference and it is very difficult to eliminate. This is due to the approximate

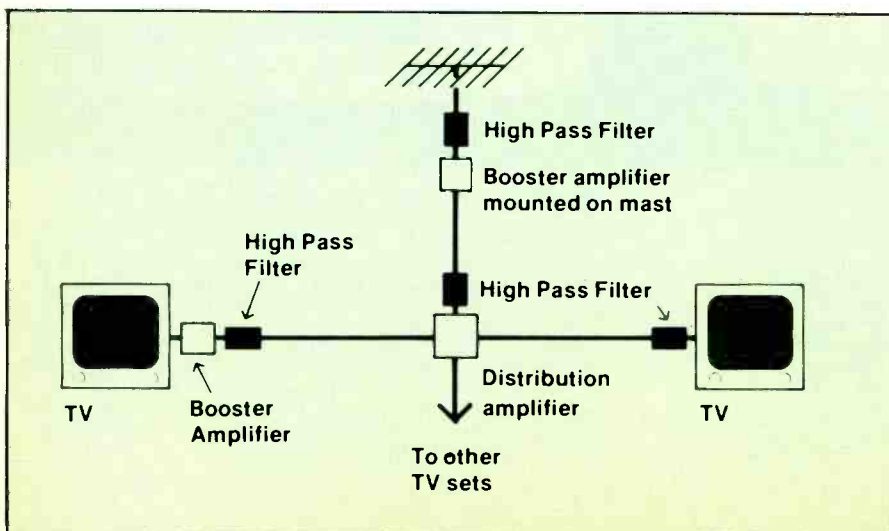

FREE!

THE NEW 104-PAGE SPRING, 1978 EDITION!



Choose from a variety of exciting new kits for spring kitbuilding fun. Nearly 400 kits in all to help you get the most from your electronic dollar!

The world's largest selection of quality electronic kits. Plus dozens of Heath-recommended name-brand products too!



Low-Cost Straight Line/White Line Chart Recording Depth Sounder



Budget-Priced Digital Alarm Clock

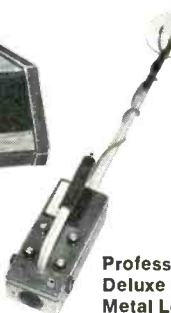

Professional-Quality Deluxe Coin-Tracking Metal Locator



Unique Electronic Digital Scale

Self-Instruction Courses In Electronics

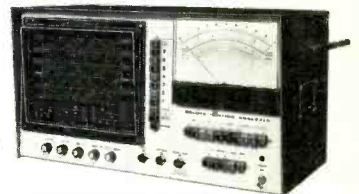
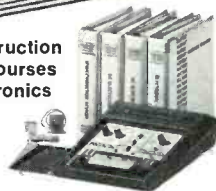

Professional-Quality Auto Engine Analyzer



Personal Computing Systems

Learn about the fascinating and rewarding hobby of electronic kitbuilding. Experience the satisfaction of owning a top-performing, high-quality electronic product that you built with your own hands.

Our easy-to-understand assembly manuals are your kitbuilding "partner" from start to finish. Large, clear illustrations and step-by-step instructions lead you to successful completion and the thrill of "turn-on". It's easy, it's fun, and it's personally satisfying.

Send for your FREE catalog today! 

FREE CATALOG SEND TODAY

HEATH
Schlumberger

Heath Company, Dept. 378-400
Benton Harbor, Michigan 49022

Please send me my FREE Heathkit Catalog.
I am not on your mailing list.

Name _____

Address _____

City _____ State _____

CL-654 _____ Zip _____



square wave output that is produced by the switching at the SCR or triac. However, bypassing may be helpful.

■ Since resolving electrical interference has to proceed on a case-by-case basis, you should always consider adequately bypassing with ceramic capacitors any component of the circuit that arcs or distorts the ac sine wave.

Identification of audio

Interference to audio devices, such as tape recorders, record players, electronic organs, telephones, and hi-fi amplifiers, is caused by the equipment responding to the transmission of a nearby radio transmitter. Audio interference, often called audio rectification, may also affect the sound portion of your tv and am/fm radio.

When this type of interference is occurring, you will hear the voice transmissions of the radio transmitter and/or the volume level of the audio device you are using may decrease. If you have determined that this is the type of interference you are receiving, these suggested methods for eliminating audio interference may help.

Audio interference is a condition that usually requires internal modification of your equipment. For safety reasons, we recommend that any modifications be made by a qualified service technician.

In the case of telephone interference, contact your local telephone company. They can install a 1542A or similar inductor in the telephone instrument to resolve the problem. Bell System personnel can obtain additional data in Section 500-150-100 of the "Bell System Practices—Plant Series" manual.

For all other audio devices, you may find the following suggestions helpful:

■ Replace unshielded wire between the amplifier and speakers with shielded wire.

■ Ground the affected equipment to a metallic cold water pipe or ground rod. A ground connection can be made with a short piece of bell wire, which can be obtained at most variety stores. Do not ground ac-dc type devices. Normally devices which may safely be grounded will provide a grounding terminal. If no terminal is provided, consult a qualified service representative for advice.

■ If the interference is not eliminated after taking these steps, call a qualified

service representative. You may also wish to discuss the matter with the operator of the radio transmitter.

Resolving audio interference

Audio interference is defined as reception of rf energy by an audio amplifier. The rf energy is then rectified, or more properly detected, by an electron tube, transistor, diode, poor solder joint or ground, or integrated circuit. The detected signal is then treated identically as a normal audio signal appearing at the amplifier input terminals.

The effects of audio interference vary with the type of modulation employed by the transmitter. The following chart shows expected effects:

■ AM—The voice or music will be heard as any normal audio signal applied to the amplifier. The voice or music may be extremely loud and slightly distorted.

■ SSB—single sideband—the voice will sound practically unintelligible and garbled.

■ FM—Usually no sound will be heard; however, a decrease in the volume of the amplifier will be noted when the radio transmitter is on. Clicks may be heard when a two-way radio transmitter is keyed and unkeyed. A "frying" noise that sounds like bacon sizzling may also be heard.

■ TV—Audio rectification of a tv signal will sound like a buzz. The buzz will change its sound as the television picture changes.

Rectification before volume

In attempting to isolate where in the audio chain the rectification is taking place, check to determine if the volume control has any effect on the interference. If the volume of the interfering signal changes with a change in the volume control, then the rectification is occurring before the volume control. If the volume control has minimal or no effect, the rectification is occurring after the volume control.

A multiple input audio amplifier may be susceptible to audio interference on only one or some of the available inputs. Generally, low-level, high-impedance inputs, such as those in turn-tables, cartridges, tape heads, or microphones, are the most susceptible.

Grounding

If, for example, the only input affected is from a turn-table, then disconnect the turn-table cartridge from the amplifier at the input terminals of the amplifier. If the interference is eliminated, then the cartridge, or wire between the cartridge and amplifier, is sensing the rf.

Proper grounding, connections, shielding, and rf bypassing are keys

to solving audio rectification. Often, a "process of elimination" approach must be used.

All grounding should be to a good earth ground such as a metallic cold water pipe or 8' ground rod. Ground leads should be as short as possible. Remember, a dc ground may appear as an open circuit to rf energy.

Ground leads should be of as large a diameter wire as practicable. Finally, grounding of the chassis, shields of speaker leads, and other external connections should be made to a common point to avoid ground loops. Ground loops are circuits that form a dc ground, but contain rf circulating currents. *Caution:* Some equipment chassis are at line voltage potential and cannot be connected directly to ground.

In these circumstances, a ceramic capacitor of 0.001 mfd at 1Kv should be placed in the ground lead. This capacitor appears as a short to rf, but an open circuit to ac.

■ Shielding—all speaker leads from audio equipment should be made of two conductor shielded wires. The shield should be grounded only at the amplifier end, and should not be used as an audio conductor. The two internal wires should be connected to the speaker.

■ Power line filter—rf may be entering the audio device through the ac power line. Several power line filters are commercially available. If necessary, a power line filter can be constructed. Place the filter as close as possible to the point where the ac cord enters the amplifier.

■ Poor electrical connections—poor solder connections or old electrolytic capacitors may be the cause of the audio rectification problem. If tests to this point have failed, try resoldering all connections in the amplifier and replacing electrolytic capacitors. Before actually replacing the electrolytic capacitor, try paralleling the capacitor with another one of like value. This should reveal the presence of a bad capacitor.

When the volume control is in its minimum position, and the interference is still heard, an rf filter is required in the

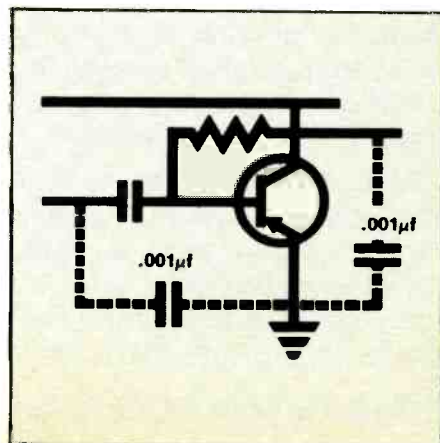

This article is a condensation of the helpful tv tips in *How To Identify and Solve Radio-Television Interference Problems*, a complete report by the Federal Communications Commission, published by Cowan Publishing Corp., 14 Vanderver Ave., Port Washington, NY 11050. Copies of the complete FCC tv book are available by mail from Cowan Publishing for \$1 plus 25c postage and handling.

audio amplifier. It's very important that the filter does not affect the audio response of the amplifier.

Tube type equipment

Interference in tube type equipment can be avoided by connecting an rf choke, ranging in value from 2 millihenry to 5 millihenry, in the upper end of the cathode circuit. The choke coil must not be bypassed by a capacitor. The dc resistance of such coil is generally quite low and the bias voltage is not greatly affected. However, if the dc resistance does affect the bias voltage, the value of the bias resistor should be decreased to compensate for the dc resistance of the choke.

A grid-stopping or "swamping" resistor can also be employed. The resistor, ranging in value from 1000 to 75,000 ohms, is connected in series with the grid.

Capacitors, rf chokes and resistors can be used in combinations to make filters to eliminate the interference. Use a choke of two to six microhenries and a capacitor of about 10 picafarads.

Transistor equipment

Interference in transistor equipment can usually be eliminated with the use of a shunt capacitor. A resistor/capacitor combination can also be used. It's important that the filter network does not affect the biasing of the transistor or the frequency response of the amplifier. The values of the capacitors used are not critical, but there are some pitfalls to look out for in using capacitors.

For example, ceramic caps are the best choice. Paper caps should be avoided, however, because they do not work at radio frequencies. Leads should be kept as short as possible. Grounds should be made directly to the emitter and not to the chassis or other grounds. If the signal increases, then a ground loop has been created, and the inductor method should be tried.

In areas of high rf energy, the inductor approach is more effective than the shunt capacitor. An rf choke should be used in series with both the input and output leads of the amplifier stage since the rf can enter a stage through either.

Organ circuits can be isolated by the use of the Swell Pedal, band box vol-

ume, or tabs (draw bars). By adjusting each one of these different controls, the effect on the interference can be noted.

If the volume of the interference changes, the rf is being detected by the amplifier at a point before that particular control. If the volume of the interference does not change, then the interference is being detected after that control. Using this method, the point at which the rf is entering the organ can be determined, and the appropriate filter inserted into the circuit.

Telephones

Telephone rf interference can be eliminated by the use of a 1542A or similar inductor. This inductor must be installed inside the phone and not at the baseboard.

To install the inductor inside the phone, the corners of the plastic container will have to be removed. If the phone is too small for the inductor, such as the "Princess" telephone, then a pair of 2.5 MH chokes (75 ma or higher) can be substituted for the 1542A filter. Install one on each side of the line and as close to the 211A equalizing network as possible. *Note:* The information provided here applies primarily to privately owned equipment and should not be applied to equipment owned by the telephone company.

Telephone company owned equipment should be modified only by tele-

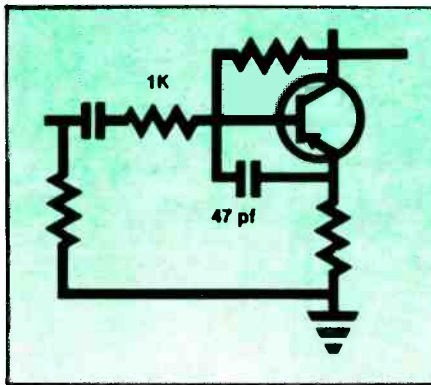

phone company personnel. Bell System personnel can obtain additional data in Section 500-150-100 of the "Bell System Practices—Plant Series" manual.

Resolving fm interference

The installation of an inexpensive *fm band rejection filter* is the first step to take in resolving fm interference. In making this installation, follow the steps outlined for purchasing and installing a high-pass filter.

There are no set procedures for eliminating fm interference. It's a matter of eliminating the most likely sources of interference a step at a time. You may be required to take several steps before the interference problem is resolved. Once you've installed the filter called for, or made the required adjustment, leave the

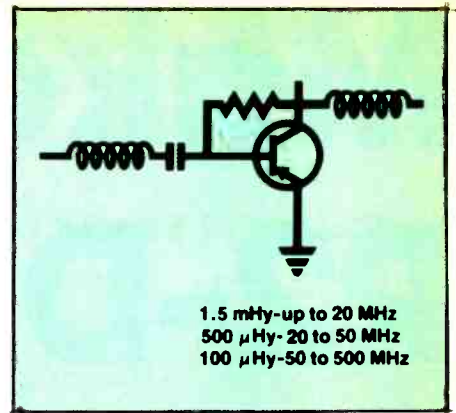

modifications in place and proceed to the next step.

To begin, check to see that an fm band rejection filter has been installed on the tv set at the antenna terminals. If the installation of an fm band rejection filter is not effective, then a tuned stub trap should be constructed.

The trap should be placed on and parallel to the lead-in and tuned for minimum interference. Then slide the trap along the line to further reduce interference. Finally, tape the trap to the lead-in in the most effective position.

Another type of stub, called an open circuit quarter-wave type, can be made from the same type of wire as the antenna lead-in wire. The initial length of the stub should be 24 inches for RG-59/U coaxial cable or 29 inches for 300 ohm twin-lead wire. If connecting the stub to the antenna terminals is not completely effective, connect a second stub of the same length directly to the input terminals of the tuner, inside the television set. This should eliminate the interference.

Amateur transmitter operators

If you have a linear amplifier on your amateur transmitting equipment, use two low-pass filters. One filter should be installed between the actual transmitter (exciter) and the input to the linear amplifier. This prevents harmonics generated in the exciter from reaching the linear amplifier. The second filter should be installed at the output of the linear amplifier to reduce harmonic and spurious content. One unique interference problem to tv channel 2 is from an amateur transmitter operating on the 6 meter band. This is due to the close proximity of the frequencies involved.

If the transmitter is not grounded, connect the chassis to a good earth ground with large diameter wire or copper strap. This should assist in elimination radiation of energy from the cabinet.

Local Television Interference (TVI) Committees are available to assist you in resolving interference problems. Contact the nearest FCC district office or the American Radio Relay League, Newington, Connecticut, for assistance in locating a TVI committee in your area. ☐

Make your own R2-D2 robot sound effects

by David L. Heiserman

Slowly the Imperial cruiser closed with the smaller ship, energy beams now scoring direct hits. Deep within the damaged vessel a golden hued human-like robot and his short, stubby cylindri-

cal companion bounced from wall to wall.

"This is madness. This time we'll be destroyed for sure," See Threepio said slowly shaking his head.

"Beep chirp, beep beep whistle chirp beep," Artoo Detoo responded.

And so began what has become the most successful movie ever made, *Star Wars*. Although the story revolves around Luke Skywalker, Ben Kenobi, Han Solo, Princess Leia, and of course, Darth Vader, it is little Artoo Detoo who has captured the viewer's imagination.

A large part of Artoo's charm is the delightful bleeping and chirping that makes up its vocabulary. Well, here's an inexpensive, easy-to-build beeper-chirper you can use to add life to your Artoo Detoo model, or your version of the *Modern Electronics* MEL robot. Its unique sound effect makes the beeper-chirper ideal for use in alarm systems too.

Beep beep

The ME Beeper-Chirper produces 16 different tones in either random or programmed sequence. The entire circuit can be built on a small printed circuit board, or can be hand wired on perforated board such as Radio Shack catalog number 276-1395.

The beeper-chirper shown in this article produces an output during the period of time the on-off switch is held in the *on* position. But, if you're into circuit design, you can also build it with a voice actuated switch and delay that gives you a response to your questions.

You also can customize your beeper-chirper to produce a series of rapid, high-pitched tones that gradually change to a lower pitch range, changing at a slower rate. This is done by connect-

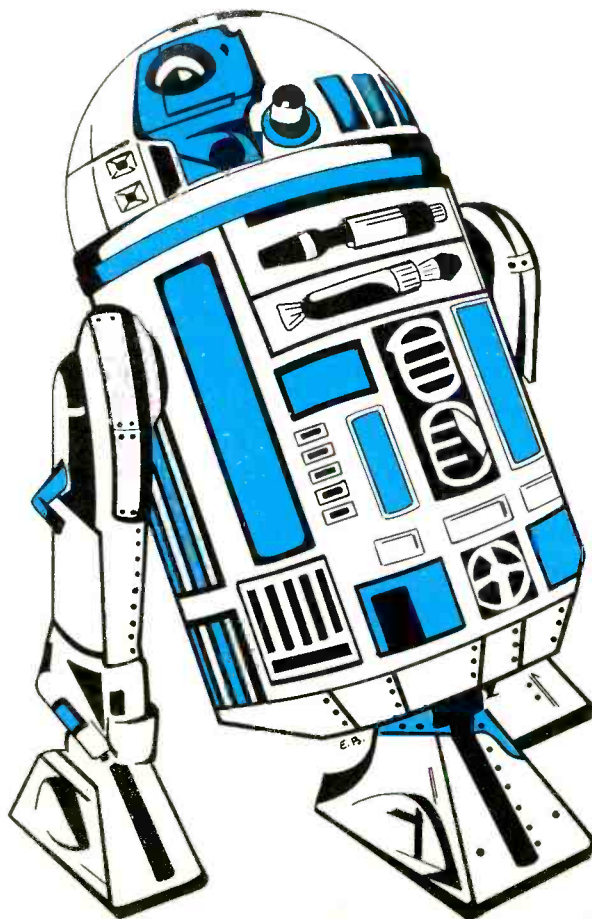

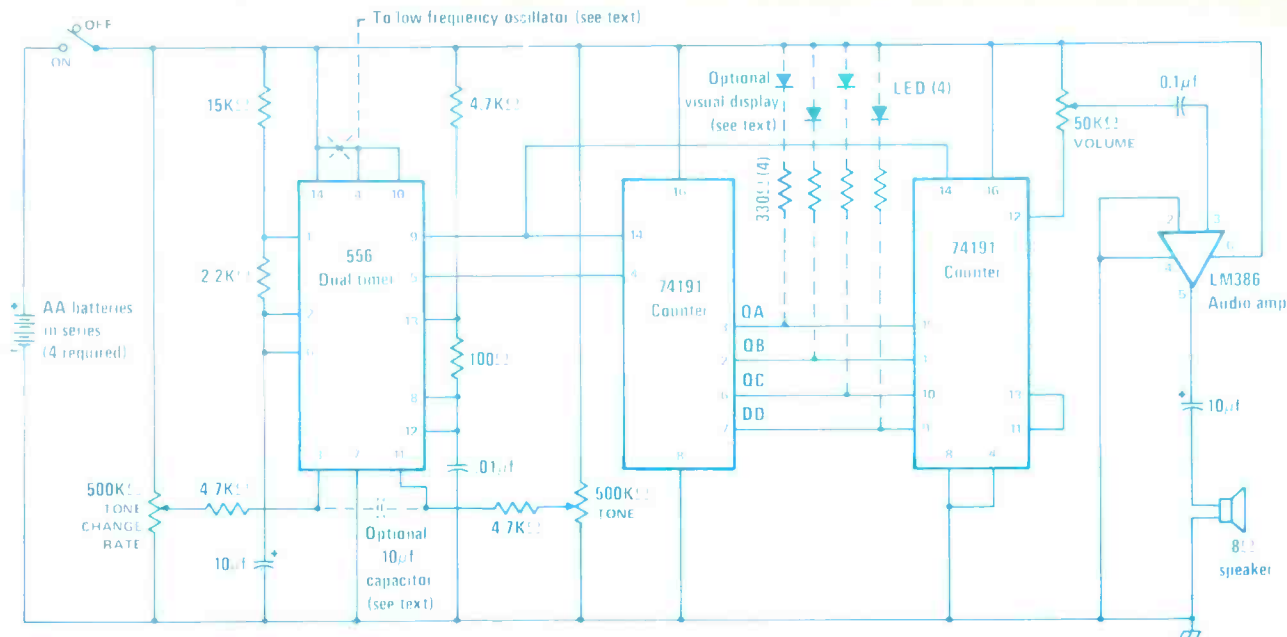

ing a 10 µF capacitor between pins 3 and 11 of the 556 timer IC.

Customize your own

If you have a 555 timer IC handy, you can add an interesting babbling effect. Just build a very-low frequency oscillator around the 555, and connect the output to pins 4 and 10 of the 556 timer IC.

You also can add a striking visual

effect by connecting an LED through a 330 resistor to each of the four Q outputs of the first 74191 counter IC. This will produce a four-LED display that twinkles in patterns that follow the sounds you're hearing.

Construction is straightforward; parts layout is not critical. You'd be wise, however, to breadboard your beeper-chirper before constructing the final unit. This will allow you to work out any

problems, and to experiment with custom modifications.

The circuit provided has both a variable tone and a variable rate. If by chance you set the two controls so that the frequency and rate are directly related, you'll get a relatively short tone-change pattern that repeats itself over and over. All you have to do to correct this is change the setting of either control.

Complete Package...\$6.95

GET YOUR HAM RADIO LICENSE THE EASY WAY

The Fun Way, The Quickest Way with the CQ/S9 learning program

The publishers of S9 and CQ Magazines have collaborated with Ameco to bring out the best ham radio training program ever offered. Just a few minutes a night, for just a few weeks will bring you the joys and rewards of being a fully licensed radio amateur.

This complete novice package includes a 1 hour code cassette course, a 32 page code instruction book, and an easy-to-use theory book with sample FCC exam questions.

All for just \$6.95.
The best training program on the market at the very best price. Order today.

Order from Circulation Department
Cowan Publishing Corp.
 14 Vanderventer Avenue
 Port Washington, N.Y. 11050

Basic

plain talk for your home computer

Modern Electronics' easy-to-understand primer on how to teach the most popular language to your home computer.

by Peter A. Stark
Contributing Editor

Basic is probably the most popular and widely used computer language for small computer hobbyists, and with good reason—it is powerful, yet simple. I'm sure you're ready to learn more about what Basic is and what it can do.

Originally invented at Dartmouth College in the early 60s, it was intended to bring the computer to the average Dartmouth student in a way that had never been tried before. The traditional approach was to place a large computer center in the corner of the campus and then force students to go to the center to run their computer programs.

Dartmouth tried the exact opposite. It placed computer terminals throughout the campus, even in dormitories, within easy reach of every student and then tempted students to use them, not only by having the terminals easy to get to but also by having a simple computer language to program the computer with. That was the beginning of Basic!

Unlike earlier languages such as Fortran or Cobol, which were intended for large programs, Basic was intended for the small uses. A Fortran and Cobol user had to prepare his programs on punched cards away from the computer. Only when he had the entire set of cards ready, would he go into the computer room and enter the cards into the computer. His program would be run on the computer, his results printed or punched back into cards, and then he would be encouraged to leave to make room for the next user. In other words, these languages kept the user away from the computer as much as possible.

Basic, on the other hand, was designed for use with terminals, such as teletypewriters, which were connected to the computer and actually using the computer for extended periods of time. A student could sit

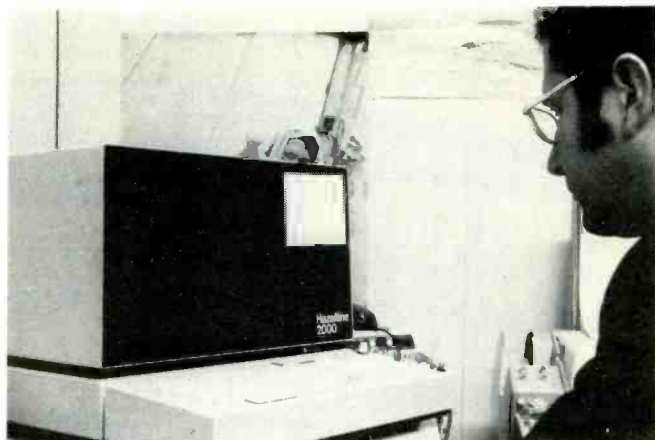

One popular computer terminal is the CRT or Cathode Ray Tube which displays a program and its results on a screen similar to a tv set.

down at a terminal and play a game against the computer for hours on end.

To make this entire idea practical in the days of million-dollar computers required the use of *time-sharing*, where dozens or perhaps even hundreds of terminals were connected to the computer at the same time. Since the computer is so fast, it easily could take care of many students using the computer at the same time, with each student having the impression he was the only user.

But now, in 1978, the entire approach has changed. For just a few hundred dollars, you can buy a small computer which can run Basic programs. Since it is no longer necessary to time-share, the computer system can be quite simple and cheap, and yet still be power-

ful enough to run sizable programs, although only one at a time.

To see just what Basic is and what we can do with it, let's sit down at a computer terminal and type in some commands, seeing what the computer does. These examples were run on a Southwest Technical Products MP-6800 home computer, but would be the same with any small home computer system.

The first thing we notice is the terminal has a keyboard similar to a typewriter, except some symbols are in new places and some keys have symbols not found on a typewriter.

For instance, above the comma is the symbol <, and above the period is the symbol >. Of special importance is a key labelled CR or RETURN, which means carriage return. This key means you are finished with a line and want to return the carriage, the part that prints on the paper, to the left, ready for the next line. Every line you enter into the computer must be followed by a CR to tell the computer you are done.

Let's sit down at the terminal and start with a CR. The computer responds with

```
READY
```

and returns to the beginning of the next line. Sometimes the computer will print a #, > or ? on the next line. This is the *prompting character* and its purpose is to tell you it's your turn to type something and the computer is waiting.

In our case we get the message

```
READY
```

```
#
```

which tells us the computer is ready, and waiting for a command. Let's enter a simple program telling the computer to print something:

```
10 PRINT 2+3
```

A one-line program like this is about as simple as you can get. Don't forget the carriage return or CR at the end. This simply tells the computer to add 2 and 3 and print the result.

Notice the number 10 in front. Every instruction of a Basic program must have a *line number* before it, and this is line number 10. The 10 does not necessarily mean that this is the tenth line of a program; it just means that we have decided to give this line the number 10. We could have just as well numbered it 1 or 500. The point behind line numbers is that every line of a program has a different line number, so at some later time we can go back and remove or change lines at will, referring to them by line numbers.

Once we have typed in a program such as this one, we can do two things with it—get a listing of it on the printer to check that we have typed it correctly, or run it. To get a listing, we type the word

```
LIST
```

and, as soon as we hit the CR, the computer responds with

```
0010 PRINT 2+3
```

```
READY
```

```
#
```

With minor changes, the computer simply types the program as we have entered it.

Notice that, up until now, we have not gotten the actual answer of 5, which the computer is supposed to print. We merely have entered the program and

checked it. To actually perform it and get our answer, we type

```
RUN
```

and the computer prints

```
5
```

```
READY
```

```
#
```

Notice that there is a difference between *lines of a program*, which *always* get a line number, and *commands* to the computer telling it what to do with the program, which *never* get a line number. The commands we use most often are LIST and RUN, but each computer system has a number of other commands such as:

■ NEW or CLEAR—Erase the program

■ SAVE—Save the program on tape or other storage for later use

■ LOAD—Load a program previously saved back into the computer

Let's erase the simple program we wrote and enter a new one:

```
NEW
```

```
READY
```

```
#10 LET I=3
```

```
#20 LET J=I + 17
```

```
#30 PRINT I, J
```

```
#
```

With one exception, every program instruction starts with a short word such as LET or PRINT right after the line number. The one exception is that the word LET may be omitted. Notice that each line has a line number. We could have numbered the lines 1, 2, 3 but this is a bad habit to get into. Very often we find, after trying to run the program, we made a mistake and have to add a few lines. With lines numbered 10, 20, 30, and so on, it's easy to slip in extra lines such as line 15 or 18. Even though we may enter them at a later time, giving them a line number between 10 and 20 will automatically tell the computer that we want them placed in that order.

In the above program, lines 10 and 20 mean just what they say. Line 10 says to let a number I be equal to 3. We have to learn the difference between *constants*, which are constant and never change, and *variables* which can vary and change. In this line, the number 3 is a constant while I is a variable. We could, for example, insert another line into the program as follows:

```
22 LET I=5
```

I thus changes—it was equal to 3 at line 10, but becomes equal to 5 at line 22. We could now get a listing of the program as follows:

```
LIST
```

```
0010 LET I=3
```

```
0020 LET J=I + 17
```

```
0022 LET I=5
```

```
0030 PRINT I, J
```

```
READY
```

```
#
```

Notice the computer automatically put line 22 in the right place, between 20 and 30.

Constants are plain numbers such as 3, 5, 17, or -12.597. There is a way of expressing very large or very small constants by using powers of 10, but that does

not concern us at this point. By their very nature, they obviously never change.

Variables, on the other hand, are represented by letters such as I or J. In fact, any of the letters A through Z can be used for variables. Since this only would allow 26 different variables, Basic also allows variables to be represented by a letter followed by a number from 0 through 9. This is very convenient for calculations on electrical circuits, since the values of resistors can be represented by the variables R1, R2, and so on.

Let's take the above program and run it.

```
RUN
5 20
READY
#
```

To understand what has happened, we have to examine the above program line by line. Line 10 told the computer to let the variable I equal 3. Line 20 says to add I (which is 3) to 17, and let J be the answer. Thus J becomes equal to 20. Then, line 22 says to let I equal 5. From this point on, I is 5, not 3, so that line 30 prints 5 for I and 20 for J.

As you can see, the computer performs these instructions in the order of their line numbers, not in the order we typed them in. This is another important use of line numbers—they specify the order in which the computer will perform its instructions.

The opposite of a PRINT statement is an INPUT. For an INPUT, the computer stops, prints a ? prompting character, and then waits for you to type in something. Let's write a short program to allow you to type in a number, have the computer multiply it by 3, and print out the answer. First erase the old program:

```
NEW
READY
#
```

Now enter a new program:

```
#10 INPUT N
#20 S = 3 * N
#30 PRINT S
```

Line 10 allows you to type in a number, which becomes the variable N. Line 20 multiplies it by 3; notice how a star * is used to mean *times*. Finally, line 30 prints out the product. If we now type:

```
#RUN
```

the computer prompts with

```
?
```

and we supply a number, such as

```
1.2
```

the computer comes back with

```
3.6
```

```
READY
```

```
#
```

This would not be much fun if we could only enter and print numbers, but Basic also allows us to use letters and words. For example, let's add the line:

```
#5 PRINT "TYPE IN A NUMBER AND I WILL MULTIPLY IT BY 3"
```

and change line 30 to read

```
#30 PRINT "THE ANSWER IS", S
```

If we list it, we get the printout

```
#LIST
```

```
0005 PRINT "TYPE IN A NUMBER AND I WILL MULTIPLY IT BY 3"
```

```
0010 INPUT N
0020 S = 3 * N
0030 PRINT "THE ANSWER IS", S
Now try running it:
#RUN
TYPE IN A NUMBER AND I WILL MULTIPLY IT BY
3
? 7
THE ANSWER IS 21
READY
#
```

As you can see, enclosing a message in quotes " and placing it in the PRINT statement makes the computer print it exactly as it stands.

Another type of variable is the *string variable*. It is signified by a letter A through Z, followed by the \$ sign. Its function is to hold a string of letters or other characters from the keyboard, but allow them to be changed, like variables, throughout a program. To illustrate, let's try a new program:

```
#NEW
READY
#10 PRINT "WHAT IS YOUR NAME?"
#20 INPUT N$
#30 PRINT N$, "IS A NICE NAME"
```

Line 20 lets us input a string of letters, while line 30 prints them out again. Watch what happens when we run the program:

```
#RUN
WHAT IS YOUR NAME?
? PETE
PETE IS A NICE NAME
READY
#
```

After inputting the name PETE, the computer printed it out again, followed by the words IS A NICE NAME. There is a large space after PETE which is put in by the computer because Basic normally prints its output spread out across the page to be in nice columns if numbers are being printed. In this case it makes the output look messy, but that is easy to get around if we use a semicolon ; in line 30 instead of a comma. This is one of the fine points in Basic, which are of little interest to the beginner but are very useful to the expert.

The tremendous power of the computer comes from the fact that programs, or portions of them, can be repeated over and over. Suppose we add one more line to the above program:

```
#40 GO TO 30
```

and run it again:

```
#RUN
WHAT IS YOUR NAME?
? PETE
PETE IS A NICE NAME
PETE IS A NICE NAME
PETE IS A NICE NAME
PETE IS A NICE NAME
PETE IS A NICE NAME
PETE IS A NICE NAME
PETE IS A NICE NAME
PETE IS A NICE NAME
PETE IS A NICE NAME
PETE IS A NICE NAME
```

Computer experts would now say the computer is *stuck in a loop*. It would keep on printing out the same line over and over if we didn't stop it by pushing a

button on the control panel. Our last line, line 40, is the culprit. It told the computer to go back to line 30 and repeat from there. Thus the computer does the printout in line 30, and the very next line sends it right back to do another printout, and so on. This is an *infinite loop*, since it never stops—unless we push a button to stop it, that is.

A better way of controlling a GO TO is with an IF instruction. For example, we can say IF X=3 GO TO 30, and the GO TO will only be done by the computer if the value of the variable X happens to be 3.

Let's change the above program so it will ask for a name, and will only print out "IS A NICE NAME" if the name happens to be PETE; otherwise, the computer will answer that the name is a poor one:

```
#10 PRINT "WHAT IS YOUR NAME?"
#20 INPUT N$
#30 IF N$ = "PETE" GO TO 60
#40 PRINT N$, "IS A POOR NAME"
#50 GO TO 10
#60 PRINT N$, "IS A NICE NAME"
#70 GO TO 10
```

As before, the computer asks WHAT IS YOUR NAME. If you answer PETE, then line 30 tells the computer to go to line 60, so that it will print the name again, followed by the words IS A NICE NAME. For any other name, the computer will *not* go to line 60, but will instead continue to line 40 and print IS A POOR NAME. Either way, a GO TO 10 returns to the top, so the computer asks for another name. Let's run it to see what happens:

```
#RUN
WHAT IS YOUR NAME?
? SAM
SAM      IS A POOR NAME
WHAT IS YOUR NAME?
? GEORGE
GEORGE   IS A POOR NAME
WHAT IS YOUR NAME?
? PETE
PETE     IS A NICE NAME
WHAT IS YOUR NAME?
?
```

As before, the computer is stuck in a loop since it keeps returning to step 10. This is usually not quite what we want. A good loop is one which has an end to it. In some way, we like to tell the computer when to get out of the loop. One common way is to count the repetitions of the loop, and stop at some predetermined number of them. For example, the following program prints out the numbers from 1 to 12 and their squares:

```
#NEW
READY
#10 LET N = 1
#20 LET S = N * N
#30 PRINT N, S
#40 LET N = N + 1
#50 IF N < 13 GO TO 20
```

Line 10 starts the number N at 1; line 20 squares it by multiplying it by itself; line 30 then prints the number N and its square S. Now, line 40 says something a bit different from what a mathematician would expect



A computer terminal's keyboard has several added keys you won't find on an ordinary typewriter. Otherwise it's similar. An important key always used is the CR or Carriage Return key, shown at right.

from $N = N + 1$ (which is not really a good equation after all.) What it means is that the computer should take the value of N, add 1 to it, and then place the result back as a new N. In other words, line 40 adds 1 to N. Since N started at 1, it is now 2. But since this is in a loop, in a little while N will go to 3, and then 4, and so on, all the way up to 12.

The symbol < in line 50 means *less than*, so this line says "if N is less than 13, go back to line 20." But eventually N will go from 12 to 13, and when that happens, line 50 no longer sends the computer back to line 20. So we have here a loop which is repeated exactly 12 times.

The IF statement is very useful, since it allows checking whether two things are equal or not. In addition to the less than or < symbol, we also use > which means *greater than*. The combination <> means *less than or greater than*, which is the same as saying *not equal*, so IF X <> 5 GO TO 300 means that if X is not equal to 5 the computer should go to line 300. Moreover, instead of ending the IF with a GO TO, we can also end with the word THEN followed by any other valid Basic instruction. Our program to judge whether a name is nice or not could have been written with these two IFs:

```
#40 IF N$ = "PETE" THEN PRINT N$, "IS A NICE NAME"
#50 IF N$ <> "PETE" THEN PRINT N$, "IS A POOR NAME"
```

Two other combinations are <= which means *less than or equal*, and >= which means *greater than or equal*.

The idea of using a variable to count the repetitions of a loop is so common and useful that Basic has a special pair of instructions just for that purpose—the FOR and NEXT pair. These always go together, the FOR at the start of the loop and the NEXT at the end. To see how they work, let's rewrite the program to square the numbers from 1 to 12:

```
#NEW
READY
```

```
#10 FOR N = 1 TO 12
#20 LET S = N * N
#30 PRINT N, S
#40 NEXT N
```

Line 10 tells the computer that N is the counter, and it is supposed to vary from 1 to 12. Initially, N starts at 1, and the computer continues down through the following steps until it gets to NEXT N. Now it adds 1 to N, and goes back to the first statement inside the loop, which is line 20. It will repeat the loop, adding 1 to N each time, until N reaches 12. When N tries to go to 13, the loop ends.

There is a variation on the FOR which lets N change in different ways; this is done by adding one more word to the line:

```
#10 FOR N = 1 TO 12 STEP 1
```

This specifies that N is supposed to go from 1 to 12 in steps of 1. If we said

```
#10 FOR N = 1 TO 12 STEP 3
```

then N would go up in steps of 3. Or if we said

```
#10 FOR N = 12 TO 1 STEP -1
```

it would go from 12 back to 1 in steps of -1. That is, N would go 12, 11, 10, 9, 8, and so on, all the way to 1. Just to see what happens, let's try running the program:

```
RUN
12 144
11 121
10 100
9 81
8 64
7 49
6 36
5 25
4 16
3 9
2 4
1 1
READY
#
```

Basic has several more possible instruction types. Some, like REM (remark) and STOP, are useful to the beginner and we will see them later in some of the demonstration programs. Others are for more advanced users and we will skip them here.

In addition to the various instruction types, Basic also has *functions* which perform specific math calculations or some other operations. For example, a mathematician or engineer might use the SIN or COS functions when working with angles. The functions likely to be used by the beginner, out of the dozen or more most computers have, are these:

■INT () converts whatever is placed inside the parentheses into the next lower integer (whole number). For example, saying

```
#10 LET J = INT(3.14)
```

would make J equal to 3.

■RND (0) makes the computer invent a random number between 0 and 1. This is usually used in games for coming up with random moves or random numbers. For instance,

```
#10 LET J = RND(0)
```

would result in J becoming equal to some unknown value between 0 and 1.

Sometimes we combine the RND and INT functions to generate other random numbers. For instance, suppose we are writing a game where the computer is supposed to pick a card from a deck of cards and print out what it is. Since there are 13 cards in a suit, we need a random number which is a whole number between 1 and 13.

If we use RND to make a number from 0 to 1, and then multiply it by 13, the result will be a number from 0 to 13. Add 1 to this, and you have a random number between 1 and 14, but always just a bit smaller than 14. Convert it to an integer with INT, and you have a whole number ranging from 1 to 13 (and never equal to 14.) The result of putting all this into one line is

```
#100 LET C=INT(RND(0) * 13+1)
```

One more function useful to beginners is the TAB(); which makes the terminal's printer or display move over to the right to the position indicated by whatever is inside the parenthesis. For example

```
#50 PRINT TAB(15); I
```

would print the value of I fifteen places from the left end of a line on the printer. Note that the TAB is used in a PRINT statement, and that it is usually followed by a semicolon.

Finally we are ready to put all this together into several simple programs. How about a program to pick five cards at random and print out what they are? We will program it as a loop which is repeated five times, use the RND function to pick a random number, and use IF statements to print out words like

JACK or KING:

```
#NEW
READY
#10 FOR I=1 TO 5
#20 LET C=INT(RND(0)*13+1)
#30 IF C<11 THEN PRINT C
#40 IF C=11 THEN PRINT "JACK"
#50 IF C=12 THEN PRINT "QUEEN"
#60 IF C=13 THEN PRINT "KING"
#70 NEXT I
#RUN
1
7
QUEEN
7
2
READY
#
```

Now let's add a few more steps to add the suit. We will use RND again to pick a number between 1 and 4, and use it to print out the suit. Add the following steps:

```
#25 LET S=INT(RND(0)*4+1)
#62 IF S=1 THEN PRINT TAB(6); "OF HEARTS"
#63 IF S=2 THEN PRINT TAB(6); "OF DIAMONDS."
#64 IF S=3 THEN PRINT TAB(6); "OF CLUBS"
#65 IF S=4 THEN PRINT TAB(6); "OF SPADES"
```

To see what the program now is, we list it:

```
#LIST
0010 FOR I=1 TO 5
0020 LET C=INT(RND(0)*13+1)
0025 LET S=INT(RND(0)*4+1)
0030 IF C<11 THEN PRINT C
0040 IF C=11 THEN PRINT "JACK"
0050 IF C=12 THEN PRINT "QUEEN"
0060 IF C=13 THEN PRINT "KING"
0062 IF S=1 THEN PRINT TAB(6); "OF HEARTS"
0063 IF S=2 THEN PRINT TAB(6); "OF
DIAMONDS"
0064 IF S=3 THEN PRINT TAB(6); "OF CLUBS"
0065 IF S=4 THEN PRINT TAB(6); "OF SPADES"
READY
#RUN
KING
    OF HEARTS
5
    OF DIAMONDS
JACK
    OF CLUBS
6
    OF DIAMONDS
JACK
    OF CLUBS
READY
#
```

We could neaten the output so each card is printed on one line, but that's more complicated. Let's do another example. How about a program to input the names of two people and print them out in alphabetical order?

```
#NEW
READY
#10 PRINT "ENTER TWO NAMES"
#20 INPUT A$, B$
#30 IF A$<B$ THEN PRINT A$, B$
#40 IF B$<A$ THEN PRINT B$, A$
#RUN
ENTER TWO NAMES
? SMITH,JONES
JONES    SMITH
READY
#
```

Notice how we are comparing two strings of letters as if they were two numbers; whichever is less is printed first. Although this example only sorts two names, we could do it for more names with a more complicated program.

Suppose a math student needs to plot an equation for his homework. The equation is $y=x^2-10x+26$, and he is supposed to find y for x going from 0 to 10. This program would do it:

```
#NEW
READY
#5 REM THIS IS A REMARK
#7 REM LET X GO FROM 0 TO 10
#10 FOR X=0 TO 10
#20 LET Y=X*X - 10*X+26
#25 REM PRINT BOTH X AND Y
#30 PRINT X, Y
```

```
#35 REM END OF LOOP
#40 NEXT X
#50 REM WHEN LOOP IS DONE, STOP
#60 STOP
#RUN
0          26
1          17
2          10
3           5
4           2
5           1
6           2
7           5
8          10
9          17
10         26
READY
#
```

Better yet, why not have the computer draw a picture? Change line 30 to `#30 PRINT TAB(Y); "*"` and run:



The computer draws a picture, as instructed in a program, to solve a math equation.

```
READY
#
```

The graph may be sideways and a little coarse, but it certainly gives the picture.

With this introduction to Basic, you're on the way to writing your own programs.

Build Thumb Thing for next to nothing

Fire off your digital circuits. Inject test signals into amplifiers and am radio circuits. Build our classy three-speed wave squarer and you can do all this and more.

by Fred Blechman

You can't get something for nothing. Or so they say. But you can get a Thumb Thing for next to nothing; about \$6 in parts. And the Thumb Thing really is something!

It's a handy-dandy three-speed square wave generator you hold in the palm of your hand. With it, you can trigger digital circuits; test amplifiers; and check out am radio circuits.

But what is it?

If you select manual operation, press the button with your thumb and you get a change of digital state from *low* to *high* or *high* to *low*. For slow speed, use your thumb to move the *rate* slide switch to slow. The logic state coming out will change about once each second. Set the same switch to *fast* with your thumb and

the output jumps up to about 460 Hz. That means the square waves change from high to low and low to high 460 times each second.

And here's a big plus bonus: power for these operations is stolen from the circuits you are testing!

Who needs it?

Control of the Thumb Thing is, literally, under your thumb. You can use it to trigger all sorts of digital counters and flip-flops and the like. Even linear devices and transistors can be fired off with this simple one-IC (integrated circuit) device. Use it to test TTL, DTL, or CMOS circuits.

The Thumb Thing provides a high or low (slow or fast) square wave clock, particularly useful with counting and

logic circuits when you want to slow things down so you can see what is happening electronically.

The square output wave is like a sine wave, only rich in harmonic frequencies up to several thousand cycles per second. That means the signal will even go through tuned circuits. That's how you can make the Thumb Thing work for you in testing amplifier and receiver circuits.

Small, compact

Although Thumb Thing can be assembled on perforated board, many of the connections are close together and it takes special care in hand wiring to prevent short circuits between adjacent connections. Using a printed circuit board layout will simplify assembly. A

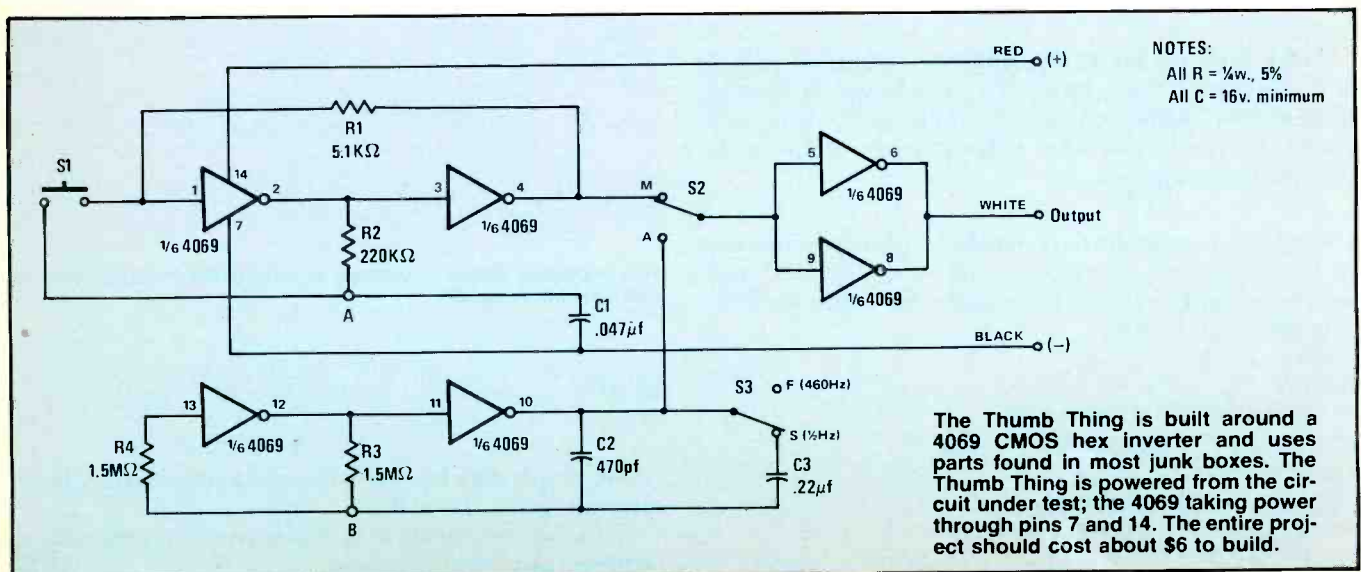

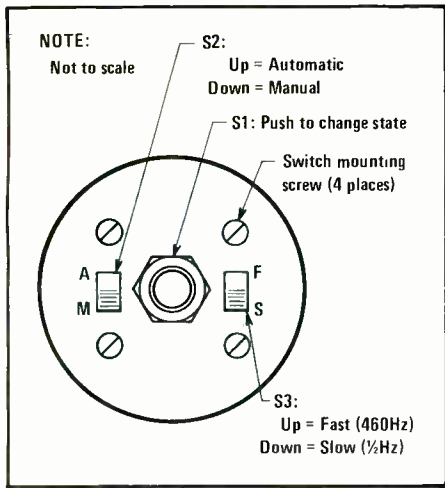

The *mode* and *frequency* slide switches are mounted beside the pushbutton using 2-56 machine screws and nuts.

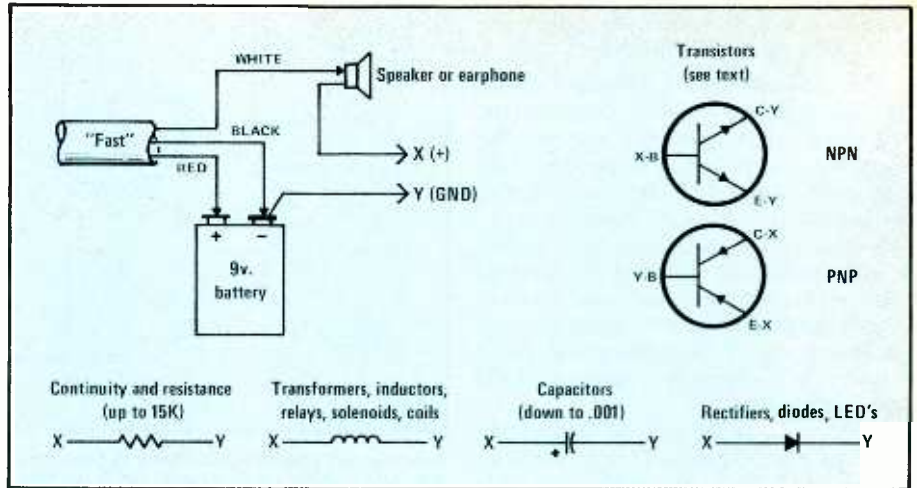

You can use your Thumb Thing to test components. Just connect the output (X) and ground (Y) leads across the components as shown. Transistors should be treated as two diodes, with the leads connects as shown for each diode junction.

complete kit of parts is available from Optoelectronics Inc., Box 219, Hollywood, FL 33022. The \$5.95 kit includes a PC board, IC and socket, three-conductor cable, subminiature slide switches and mini-alligator clips with insulators.

The case can be a small plastic pill bottle or any other enclosure of sufficient size to hold the PC board. However, an *ideal* case is a 35MM film container, which you can get from any film dealer. These are made from a soft plastic easily cut with a razor blade or X-acto knife, and the cap snaps firmly on the formed rim of the can.

Cut a hole in the bottom large enough for the three-conductor cable, and cut holes in the cap for the three switches.

The pushbutton switch is held in position with the large nut that comes with it. The subminiature slide switches are held to the cap with #2-56 screws and nuts.

Insert the components into the top (non-foil) side of the PC board, following the layout shown. The PC board supplied with the kit is pre-drilled and silk-screened with the parts locations and switch wiring points. Solder carefully to the foil side, using 0.031 diameter resin-core solder and a fine-tipped 25 to 50 watt soldering iron. Clip off the excess leads and examine the soldering carefully for unintentional solder bridges across the gaps between foil strips.

Next, wire the PC board assembly to the cap switches. The top edge of the PC board fits between the solder lugs of the

pushbutton, with the component side facing S2 (mode) and the foil side facing S3 (rate). Follow the wiring diagram.

Particular care should be paid to making the connection to the pushbutton on the foil side of the board. First bend the pushbutton lug upward, away from the board, and then use a short solid wire jumper to the PC board. The jumper can be a clipped-off component lead. This insures that the switch terminal will not contact the solder at points M or A on the PC board.

Imaginative uses

Now connect one end of the three-wire cable to the PC board, observing the wire colors as shown in the wiring diagram. Solder the clips on the other ends of the wires, slip the proper col-

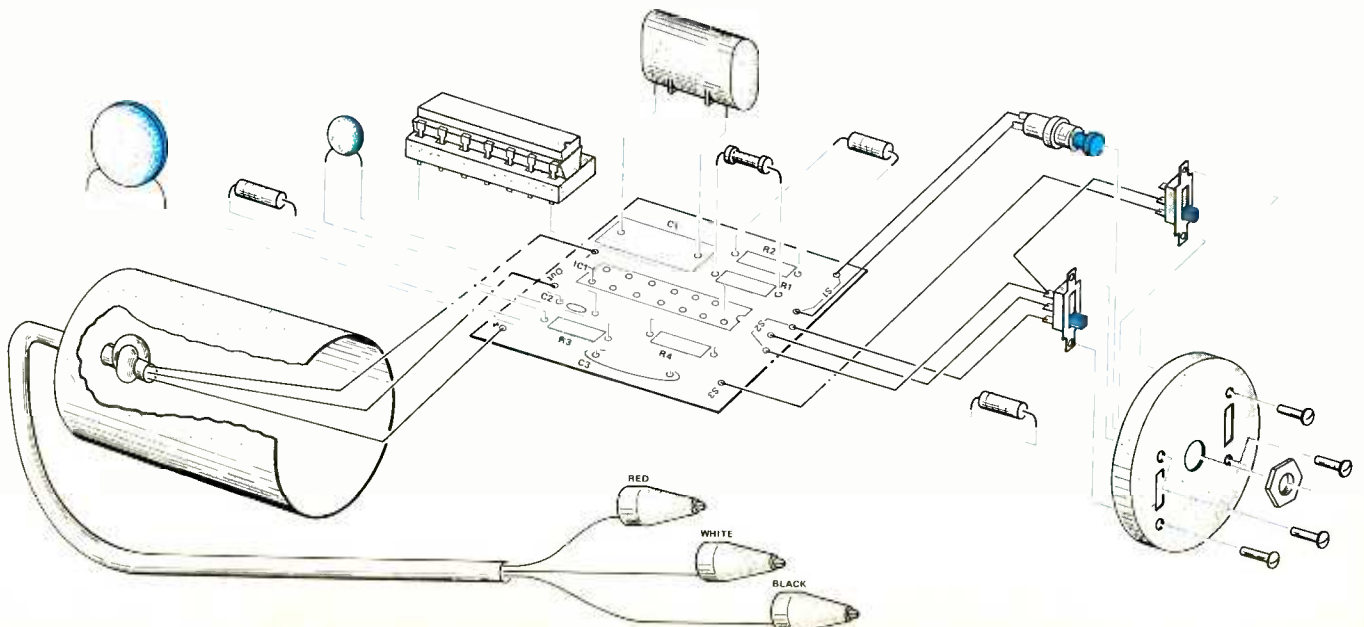

ored insulator over each clip, and your Thumb-Thing is complete!

The basic use for the Thumb-Thing is to trigger digital circuits. Connect the red clip to circuit positive voltage, the black clip to ground, and use the white clip as the *trigger*, setting the switches for manual or automatic operation.

In the manual mode, you can operate a counting circuit, holding the desired state as long as you want. You also can determine if the circuit operates on a positive-going or negative-going pulse edge with a voltmeter, scope or LED status indicator.

If you want to add an LED status indicator to your Thumb-Thing, you can mount the LED in the cap of the case permanently. However, the current requirement for the Thumb-Thing will go from about 1 ma without the LED to over 5 ma with the LED. In manual mode the LED will light when the output is high. In the automatic mode it will blink at the cycle rate when in the slow mode, and appear to be on all the time when in *fast* mode, although it's only on half the time.

The Thumb-Thing also can be useful in testing amplifiers, radios and many

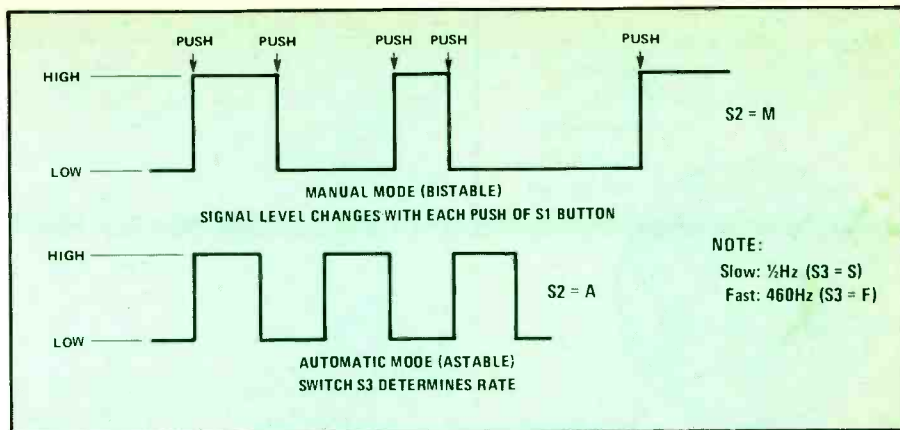

You can set your Thumb Thing to provide a continuous square wave output, as shown on the lower trace, of 1/2 or 460 Hz. You can also operate your Thumb Thing manually, as shown on the upper trace. When operated manually, the output state changes each time the pushbutton is depressed.

Connect the negative lead of the battery to the circuit ground of the radio you're testing. Use a 0.01 mfd capacitor of sufficient voltage to isolate the circuits. Probe the radio circuits using the Thumb-Thing in its fast automatic mode as a signal injector. It has sufficient power to drive the speaker, so start

application, it should be set for *fast*. When testing resistive devices, the sound from the speaker will be loudest when resistance is lowest. You'll still be able to hear some sound with up to 15,000 ohms in series with the speaker.

Tests almost anything

When testing capacitors, the larger the capacitance, the louder the sound through the speaker. Capacitors as small as 0.001 mfd (1000 pf) still will be audible. When testing polarized capacitors (electrolytic, tantalum, etc.) be sure test point X is connected to the positive lead.

The rectifier/diode/LED test determines both condition and polarity, since the speaker is silent if the component connection is reversed. An LED under test will light when properly connected, with current limiting provided by the IC output and the speaker impedance.

Transistors are tested as if they were composed of two diodes with a common base. First determine which leads are the base, and alternately connect Y to the collector and emitter. Speaker sound in *both* cases tells you the transistor is a functioning NPN type. If the speaker is silent, reverse the leads so test lead Y is connected to the base, and X alternately connected to the collector and emitter. Sound now means you have a functioning PNP transistor.

Many other components, such as switches, incandescent bulbs, photocells, earphones, some microphones, potentiometers, and patch cords can be tested for continuity. You can use any battery from 5 to 15 volts for these tests. If you choose, you can build the Thumb-Thing circuitry in a larger case to include a battery, LED and speaker and have a portable universal tester!

Simple, small, inexpensive, portable, easy to build and versatile in its applications, the Thumb-Thing can become one of your most useful pieces of test equipment.

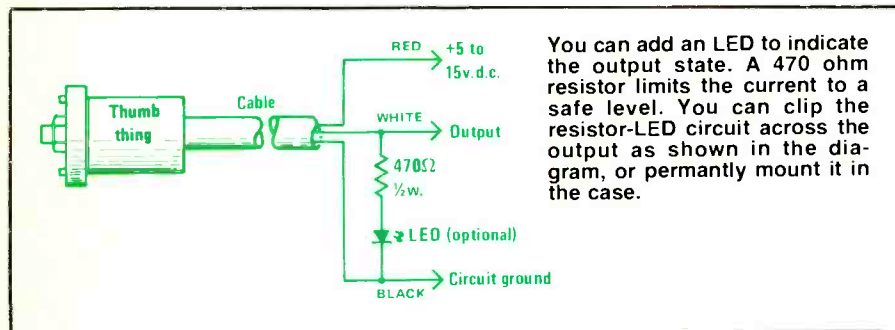

You can add an LED to indicate the output state. A 470 ohm resistor limits the current to a safe level. You can clip the resistor-LED circuit across the output as shown in the diagram, or permanently mount it in the case.

electronic components. In typical transistor radios, which operate on 6, 9, or 12 volts, the Thumb-Thing can be powered by the radio power supply. If this is inconvenient, use a standard nine-volt transistor radio battery, 2U6 or equivalent, to power the Thumb-Thing.

there and move backwards through the circuitry until you find a dead stage. At that point, voltage and continuity checks will isolate the bad part.

Using a nine-volt battery and a small speaker, you can put the Thumb-Thing to work as a component tester. In this

Parts List

IC	CMOS 4069 or 4069B
R	all resistors 1/4 watt 5% carbon
R1	5.1 K ohm
R2	220 K ohm
R3	1.5 Meg ohm
R4	1.5 Meg ohm
C	all capacitors disc ceramic, 16 volts dc minimum
C1	0.047 mfd
C2	470 pf
C3	0.22 mfd
S1	pushbutton switch, normally open
S2	subminiature slide switch, SPDT
S3	subminiature slide switch, SPDT
Misc.	PC board, 14-pin IC socket, 3-conductor cable, 3 mini-alligator clips, 3 colored clip insulators, nuts, screws, enclosure

A complete kit of parts, with all items in the parts list except the enclosure, is available from Optoelectronics Inc., Box 219, Hollywood, FL 33022. Kit TT-1 is \$7.25 each including \$5.95 kit price, 30¢ shipping and insurance for each kit and a \$1 handling charge for orders under \$15. Florida residents add 4% sales tax (24¢ per kit).

Ring my chimes!

Here's how you can use the popular Heath Westminster chimes kit with just about any of the digital clock integrated-circuit chips on the market today. You build the clock and Heath will ring your chimes.

by Fred Blechman

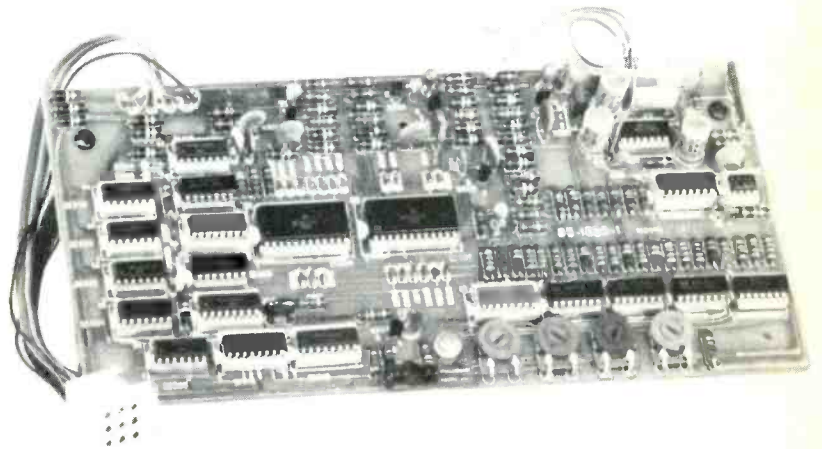

If you enjoy customizing and want a really unusual conversation piece, you can add Heathkit's Westminster Chimes Accessory to any digital clock using the 12 most popular clock integrated circuits. The Heath Company, Benton Harbor, MI 49022, makes an electronic synthesizer that simulates the chimes.

It plays four notes on the quarter-hour, eight notes on the half-hour, and

12 notes on the three-quarter hour. At the beginning of each hour, it plays the full 16-note melody, followed by a monotone striking the number of hours. It also tick-tocks the seconds constantly, just like an old-fashioned pendulum clock.

Although the Westminster Chimes Accessory Kit (\$69.95) is designed to be used exclusively with Heath's Floor and

Shelf Super Clocks, it can be adapted to other circuits. But any other use voids the Heath warranty. Heath will *not* provide information on how to mate their chimes with other clocks.

Table 1 shows the clock chips that readily work with the Heath Westminster Chimes. The chips need to be wired for a 12-hour display, *not* multiplexed, have positive *segment on* outputs, and have a one Hz output pin. The input to the chip may be 50 or 60 Hz from a 117v or 220v ac line, but the positive voltage applied to the chimes should not exceed 18 volts dc. Although no 28-pin chips qualify, many 40-pin chips do.

Clock with chimes

Adding the chimes to a clock using one of the IC's shown in Table 1, involves connecting seven logic leads and two power-supply leads to the pins shown.

An ideal clock for this accessory is the Mini-Grandfather Digital Clock, MG-01, offered in kit form (\$39.95) by Bullet Electronics, PO Box 19442E, Dallas, TX 75219. A custom, solid hardwood case is \$19.95.

This clock kit features a swinging electronic LED pendulum and a large 0.5-inch high LED display. Although logic circuitry and an amplifier for hour-counting chimes and tick-tock sound are included, the Westminster melody is not.

All the clock chips listed in Table 1 operate in the same general manner.

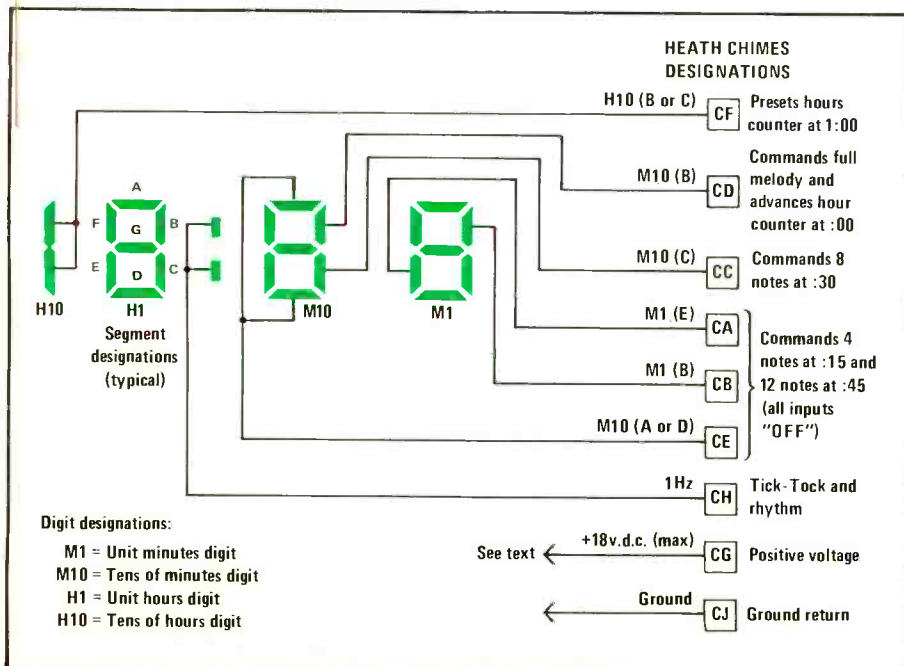

The Westminster chimes kit is designed for use only with the Heath Super Clock. The connections between the clock and chime kits are shown in the diagram, as are the functions of each interconnect.

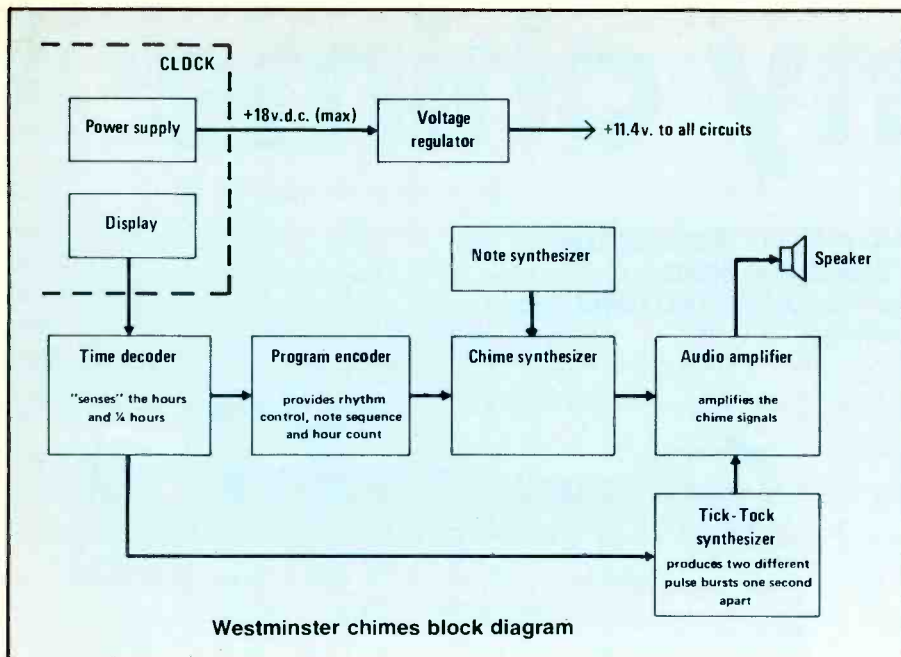

Westminster chimes block diagram

The input line frequency is counted and the minutes and hours are decoded into a four-digit seven-segment format. The

The following are sources for the Clock Chips listed in Table I:

Bullet Electronics
PO Box 19442E
Dallas, TX 75219

National Semiconductor Corporation
2900 Semiconductor Drive
Santa Clara, CA 95051

Digital Concepts Corporation
249 Route 46
Saddle Brook, NJ 07662

Fairchild Camera & Instrument Corporation
4001 Miranda Ave
Palo Alto, CA 94304

Heath chimes use seven wires of a nine-wire cable for logic input signals. This lets the chimes circuitry know when to play which melody, and how many times to strike the hour count. The wiring diagram shows where these seven wires are connected in typical clock displays.

The other two wires in the cable connect to your clock power supply. The supply may, however, need to be beefed up with a larger transformer to handle the extra power required by the chimes.

The chimes do not come with a cabinet, since they are intended to be installed in the Heath Super-Clock cabinets. You'll have to exercise your own packaging ingenuity to suit your requirements.

Most digital clocks aren't clocks at all. They're really just educated on-off switches that count changes in your ac power line voltage. Here's a simple explanation of how these switches keep track of time.

by Bob Margolin

Whether built into a tiny wristwatch or table-top clock with jumbo readouts, the heart of digital clocks is a tiny integrated circuit. And built into this marvelous chip are hundreds of resistors, capacitors, diodes and transistors—all there to count time. That's right, *count* time.

Although these ICs are called *clock* chips, they really aren't clocks at all; rather, they're counters or scalars. They count the number of cycles of ac voltage being generated by your local power company, or by a crystal oscillator time base. What makes clock counters different from other counters is the way they count.

The counters in a clock chip are basically *decade* counters—they count by ones from zero to nine and then reset to zero to begin counting again. But decade counters are themselves just fancy binary counters.

Binary counters are really nothing more than on-off switches. By definition, a switch in its *off* position is said to be *low* or at its *zero* state. A switch in its *on* position is said to be *high* or at its *one* state. So a binary counter has an output of either 0 or 1.

In order to count large numbers, many binary counters are connected together to build a higher capacity counter. Each succeeding stage of the counter advances from 0 to 1 when the preceding stage resets from 1 back to 0 to begin a new count. The following table shows how a six-stage binary counter counts from zero to 63.

If the output of the third, fourth, fifth and sixth counters were applied to an AND gate, the gate would have a high output only when all four counters were high. As you can see from the table, the four counters are all high only after the 60th count.

If the AND gate output were to be connected to a *reset* line that caused all of the counters to reset to zero when the line was high, the counter could never reach a count of 60. As the count went from 59 to 60, the AND gate output would go high, and the counters would all reset to zero.

If a two-digit decade counter were connected to the first counter so that it advanced its count by one every time the

Table 1
WESTMINSTER CHIMES CONNECTIONS

Display segment or function	M1 E	M1 B	M10 C	M10 B	M10 A or D	H10 B or C	+18v.d.c. (max)	1Hz	Ground	
Heath wire no.	CA	CB	CC	CD	CE	CF	CG	CH	CJ	
Clock IC										
Bullet	FCM-7010	7	11	15	14	16	27 or 28	1	36	2
National semiconductor	5316	20	19	15	13	12	2	28	39	29
	5384	21	22	26	28	29	39	13	2	12
	5385	22	23	27	29	30 or 31	1 or 2	13	4 or 5	12
	5387AA	20	19	15	13	12	2	28	39	29
	5396	19	18	14	12	10 or 11	39 or 40	28	36 or 37	29
	5402	20	19	15	13	12	2	29	39	28
	5405	21	22	26	28	29	39	12	2	13
	53108	21	22	26	28	29	39	13	2	12
Digital concepts	DCC-7301	20	19	15	13	12	2	28	39	29
	DCC-7302	25	22	30	29	28	4 or 5	1	6	18
Fairchild	3817	20	19	15	13	12	2	28	39	29

NOTES:

- 5316, DCC-7301 and 3817 are interchangeable in most applications.
- 53108 is mirror-image pinout of 5316.
- 3817 is used in Heath "SUPER-CLOCKS".

You can use your Westminster chimes with any digital clock built around one of the twelve clock chips listed in the table. Just connect the Heath-coded wires to the IC pins for the chip used.

Digital Clocks: what makes them tick

first counter reset to zero, you would have the basis of a seconds-counting clock. All you would have to do is connect the first counter to a 60 Hz ac power line, observing proper safety precautions, of course.

Since a 60 Hz voltage has 60 cycles each second, the first counter would reset to zero once each second, causing the second counter to advance its count. If the second counter reset when its count reached 60, it would reset once each minute. Connecting a second decade counter would then give you a minutes count.

If the second decade counter were made to reset at a count of 60 too, it would reset once each hour. Adding a third counter would complete the clock circuitry. Then you'd only need to add a readout system to complete your clock.

The first digital readouts employed a string of 10 lamps, each representing one of the ten digits between zero and nine. To determine the count, you had to read the digit printed on the panel next to the lamp that was on. Although simple to construct, and very reliable, this readout wasn't very convenient to use.

The next step in digital readouts was the Burroughs' *Nixie* tube. Instead of a string of 10 lamps, the *Nixie* tube contained in a single glass envelope ten independent elements, each shaped into the form of one of the digits from zero to nine. The envelope was filled with neon gas, and when a high voltage was applied to one of the elements, it glowed just as a neon bulb would. The result was a display in which you could actually see

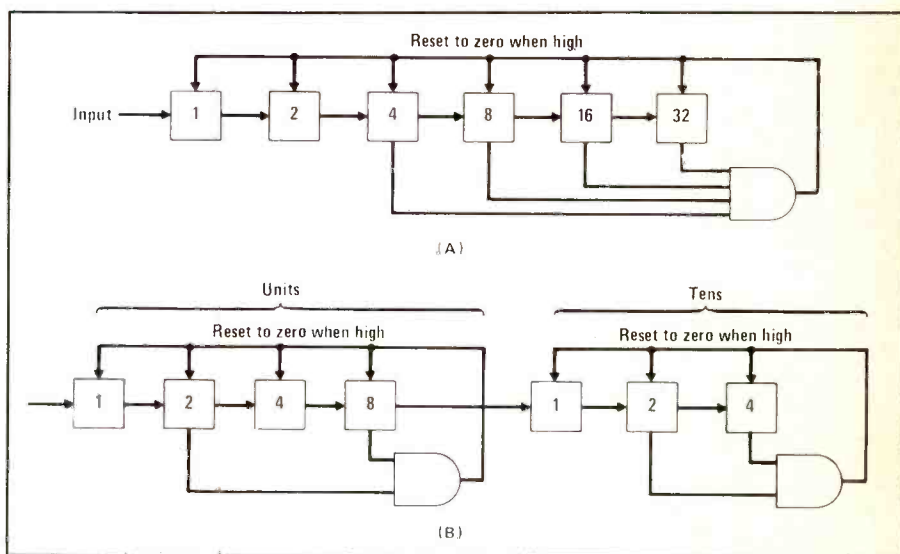

A simple binary counter (A) is used to convert the 60 Hz power line frequency into a seconds count. When the four, eight, 16 and 32 counters are high, the AND gate output goes high, resetting the counter zero. To get a decimal readout, you'll need a two-digit decade counter (B).

numerals changing before your eyes as the count changed.

The latest in digital readouts is the seven-segment display. Some of these displays work on a principle similar to the old *Nixie* tube—gas discharge. Others use light emitting diodes (LED). But regardless of the method used to illuminate the display, the principle of operation is the same.

In a seven-segment display, each digit from zero to nine is represented by some combination of segments. A zero, for example, uses the six outer segments. Adding the seventh segment creates an

eight. Eliminating the lower left and bottom segments creates a nine. The trick is electronically to convert the clock output into the right combination of segments to produce the right display.

Looking back at the clock counters, you'll see that the seconds and minutes counters each have six binary stages. By connecting each of the six outputs to a logic matrix consisting of AND gates, you could obtain the correct segment signals.

The hours display would be easier to get because the tens display in a 12-hour clock is either a one or not on at all. Even with a 24-hour clock, there's only one more possibility—a two. But the basic logic matrix would be the same as the one used for seconds and minutes.

Of course, you don't have to go to the trouble of designing and building a logic matrix any more than you have to build your own multi-stage binary counters. It's all contained in the clock IC. All you have to do is connect the clock outputs to the seven-segment displays and you're in business. Of course, if you're using large displays, or gas discharge units, you'll have to add the appropriate drivers.

If you'd like to build your own digital clock, you'll find *Modu-Clock* you can build yourself on page 64.



SCANNERS

ALL CARS IN VICINITY OF 45TH AND 5TH. OFFICERS IN SHOOT OUT AT CITIBANK WITH TWO PERPS AND REQUEST A 10-78 ALL UNITS RESPOND CODE 3.

SAVE LIVES!

WE JOIN JACK HARRIS AS HE MONITORS HIS COMPUTERIZED SCANNER. WHILE LISTENING, HE DAY-DREAMS ABOUT PARTICIPATING IN THE HEROICS HE IS HEARING ABOUT.

BY: HAROLD A. PERRY



OPERATIONS TO ONE BRIAN XRAY. WE HAVE A 10-200 AT DOUGLSTON POND NORTH END. KID ON ICE. RESPOND CODE 3.

HEY, THAT'S RIGHT ACROSS THE STREET!

OPERATIONS THIS IS ONE BRIAN XRAY. NEGATIVE ON THAT 10-200. WE'VE GOT A 10-50. UNABLE TO RESPOND. SUGGEST YOU CALL UNIT FROM ANOTHER SECTOR.

10-4 ONE BRIAN XRAY.

KNOWING THAT A POLICE CAR FROM ANOTHER SECTOR CAN'T REACH THE CHILD IN TIME, JACK TAKES ACTION.

I'LL SAVE THAT KID MYSELF.

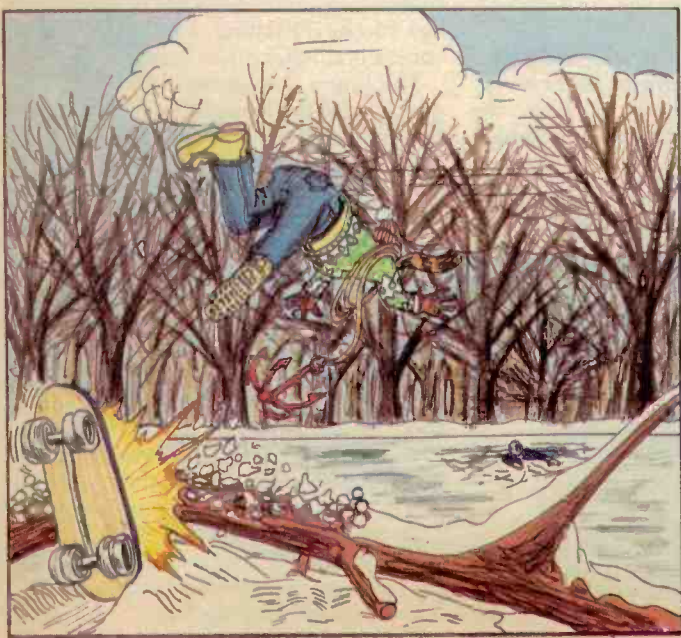

HURLING ACROSS THE ICE OUT OF CONTROL, JACK MANAGES TO GRAB THE HOOK.



AS HE SWOOPS BY, JACK SNAGS THE BOY'S HOOD.

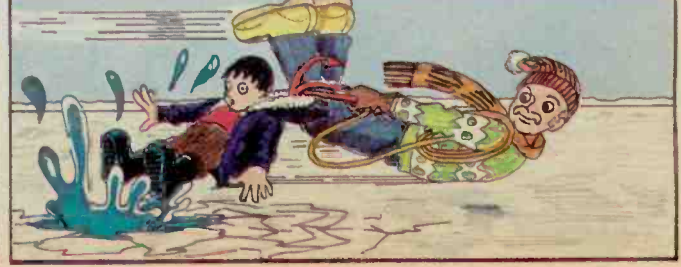

JACK SLOWS TO A STOP, THEN WALKS TO SHORE AND AN ANXIOUS MOTHER.



THEN, AS JACK PULLS HIMSELF TO THE SURFACE



LISTEN HERE, KID. MY NAME IS LOU GRUNT. I'M A REPORTER AND I SMELL A STORY. YOU TELL ME EVERYTHING AND I'LL MAKE YOU A HERO. YOUR NAME WILL BE A HOUSEHOLD WORD. Y'KNOW, LIKE THAT GUY WHA-TIZNAME, WHO - CLIMBED TO THE TOP OF THE WORLD TRADE CENTER.

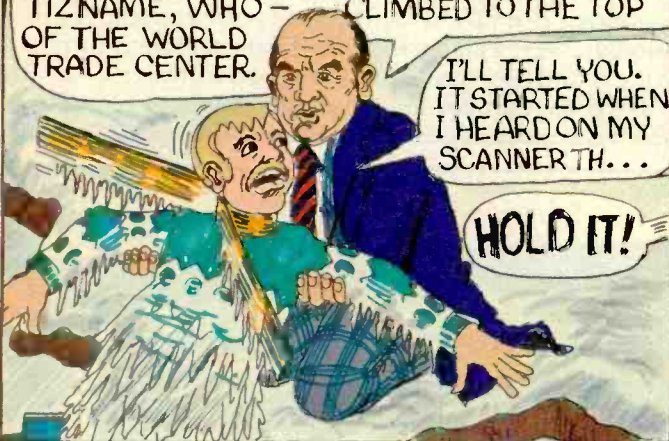

I'LL TELL YOU. IT STARTED WHEN I HEARD ON MY SCANNER TH...

HOLD IT!

YOU'D BETTER CLAM UP KOOTCHIE KOO. REVEALING WHAT YOU HEAR ON A SCANNER IS A NO-NO. AND WE'RE THE FUZZ. YOU DIG IT, BABY?



WHAT KIND OF STUPID LAW IS THAT?

LISTEN, FURRY LIP. THAT LAW WAS MADE TO PROTECT THE RIGHTS AND PRIVACY OF GUYS LIKE YOU. YOU'D GET MAD IF I WENT AROUND BLABBIN' ABOUT YOUR PERSONAL PHONE CALLS.



SO AS JACK HARRIS MELTS INTO THE SUNSET, WE SALUTE HIM AND ALL THE OTHER UNSUNG HEROES THROUGHOUT THE PAGES OF HISTORY.



THE END

gear parts tests books

The editors roundup exciting new products you should know about.



Where'd red go?

LEDs are neat because the tiny red lights are eye catching and easy to see in the night. But they eat batteries. Whenever you use electricity to generate light or heat, it consumes a lot of current. And there's only so much available in the tiny batteries in wristwatches. LCDs, on the other hand, don't generate light. They reflect it, thereby using much less current. Batteries last longer. Manufacturers have jumped off the LED bandwagon like rats off a sinking ship. LCDs are in this year. These, for example, are \$14-\$24 LCDs from Texas Instruments. How does TI fix it so you can see your LCD at night? They add Tritium backlighting, making the numerals show up as shadows against a greenish glow. For more information, circle number 158 on our reader-service card.

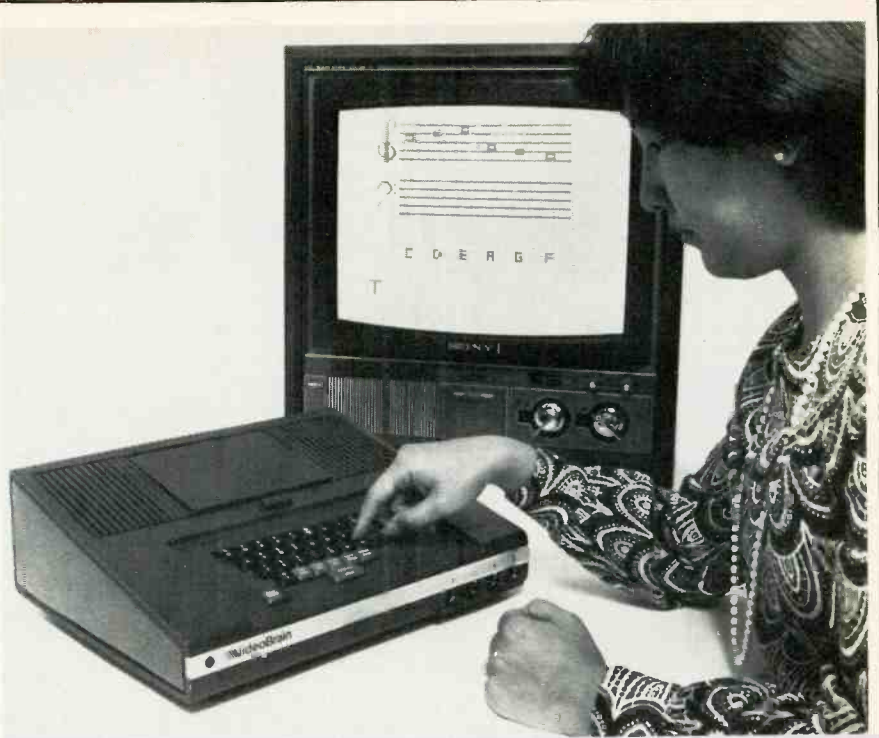

Computer entertainment

You really don't have to be a programmer to operate a home computer like the \$500 VideoBrain from Umtech. It comes with a preprogrammed library of educational, home management and entertainment programs. It hooks up to your tv and runs programs stored on cartridges. For more information, please circle number 155 on our reader-service card.



Match box

Just the thing for apartment dwellers and other shortwave listeners, hams and CBers with no-space antenna problems. The \$79 Versa Tuner II from MFJ Enterprises is an efficient means of matching a transmitter or receiver to an antenna for best reception or peak transmission. The tuner has a built-in SWR bridge with meter plus a transmitter power meter with ranges up to 30 watts for CB or QRP ham and up to 300 watts for other ham gear. A back-panel switch allows you to select from coax-fed, balanced-line or random-wire antennas. If you're stuck in an apartment with an indoors antenna, the tuner will match your rig to a wire of random length hung from the draperies. It's 8x2x6 inches in an eggshell-white case with walnut-grain sides. For more information on the tuner, circle number 170 on the reader-service card.



Microradio

It had to happen sooner or later. The extra-tiny microcassette recorders are a natural companion for small transistor radios. Pearlcor has mated the two in its \$199 SR-501, the first micro to have am and fm tuners built in. The recorder has capstan drive and a sleep switch for 30 minutes of either am/fm music or recording playback before automatically shutting off. An electret mic is built in along with a tape counter and audio tone control. For more information, circle number 162 on the reader service card.



Scotch tape

When you need new tape cassettes for your Beta-format home videotape recorder, look for 3M Company's \$12.45 L-250, for 30-60 minute length, or the \$16.95 L-500, for 60-120 minute recordings. These Scotch tapes are the same quality as video tapes for broadcast, industrial and educational use. For more information, please circle number 154 on our reader-service card.



220 ham rig

We like to think repeaters are about the best thing that's happened in ham radio since sideband 20 years ago. At least, the best in terms of stirring up enthusiasm and activity. First repeaters were in the very high frequency (vhf) two-meter ham band from 144-148 MHz. Next came repeaters operating in the 70 cm band from 420-450 MHz. Other machines are on the air now in the 1¼-meter, 6-meter and 10-meter bands. In fact, 1¼ meters, from 220-225 MHz may be the biggest growth area right now with new machines going on the air every month. About the sexiest, and most convenient radio for 220 MHz, is the synthesized model 13-513 from Midland. It covers the entire band and gives the ham operator the ability to work any machine within range. For more information, please circle number 165 on our reader-service card.



Black-panel CB

Colt has a new-style \$69 40-channel CB radio with unusual front-panel styling. It's chrome-finished matte black metal, sectionalized for quick recognition of controls. Knobs and switches include automatic noise limiter, rf gain control, modulation and on-the-air lamps, LED digital channel readout and an illuminated meter to read power and received-signal strength. For more information, please circle number 169 on the reader-service card.

Cassette computer

Now there's a second computer controlled cassette tape deck available as a stereo component. Optonica High Fidelity Products' \$360 model RT-6501, with five memories, can be programmed to turn itself on and off, to record or to playback. It has both electronic memory rewind and tape counter memory. It even can be programmed to play a particular segment of tape. Its automatic program locate device can be programmed to find the beginning and play any song on a cassette by going either fast forward or fast rewind. For more information, please circle number 157 on the reader-service card.



platt

CASES FOR BUSINESS AND INDUSTRY.
2101 S. Prairie Ave., Chicago, Ill. 60616 312 223-6670

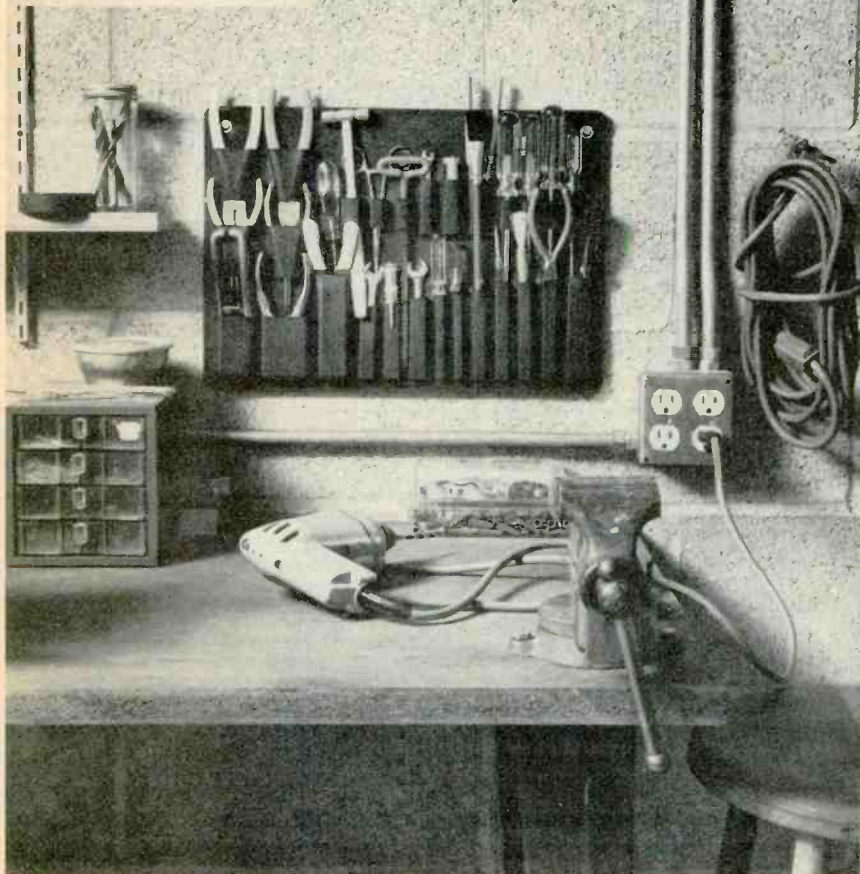

No grit, no grime

There's nothing like a clean and neat shop. Here's how a luggage company can help organize your tools. Platt Luggage Inc. makes the Platt pallet, molded of tough plastic, to hold lots of different small tools. Put it up next to your bench and keep the tools out of grit and the grime out of your toolbox. It's hard to lose them in this one-piece set of pockets with no seams, flaps or rivets. For more information, circle number 168 on the reader-service card.

Tall sounds

Racks to stack up your stereo components are all the rage this year. Not to be outdone, JVC has this MusicTower which is a flexible standup cabinet to hold different mixtures of hi-fi components plus LPs in the bottom. The largest MusicTower is model LX-3000 at 63.6 inches high. It's 22.6 inches wide and 22.3 inches deep, intended for radio stations and recording studios. We show model LK-905 for the home at 49.5 inches high, 21.7 inches wide and 17.8 inches deep. LK-905 is finished in black wood. For more information, please circle number 167 on the reader-service card.

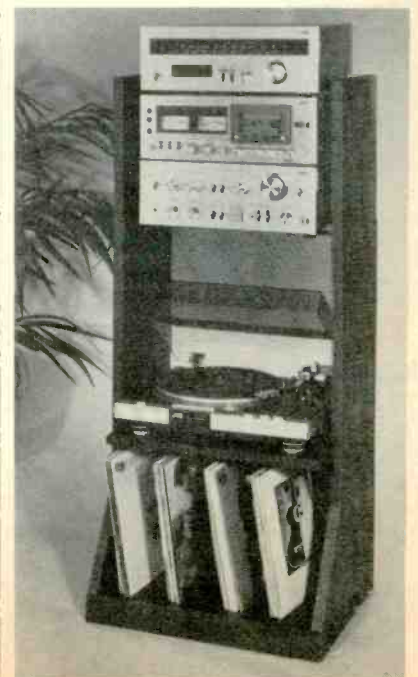

Computer output

Having a computer is not enough. You have to find a means of communicating with, to instruct it and receive its responses. The pieces of equipment through which you communicate are accessories known as input/output (I/O) devices. One such inexpensive output device is the \$257 Miniprinter from Electronic Product Associates. It's a 5x7 dot matrix printer using electro-sensitive paper to make permanent copies at speeds up to 88 characters per second with 44 characters per line. Black letters are printed on aluminum paper about 2½ inches wide. Your computer controls the Miniprinter motor and printing electrodes. You have to provide a power supply of 40 volts at one amp to run the model MP-44. For more information, please circle number 156 on our reader-service card.



The editors roundup exciting new products you should know about.

gear parts tests books



Two for the price of one

Among a zillion color tv sets introduced this year is one sharp idea: Dualvision from Sharp Electronics. It has remote control and 21-inch color screen. And it's possible to watch a second channel in black and white at the same time you're watching a color picture. A six-inch black and white picture is superimposed on the main color screen. It can be located either in the upper right-hand or lower left-hand corner of the main color screen. Audio accompanying the black and white picture can be heard via a headset. Also, you can switch pictures so the black and white image becomes the main picture and the color image becomes smaller. For more information, circle number 161 on our reader-service card.

Microflame

Sixteen-bit microprocessors will replace eight-bit chips in home computers eventually. They are more powerful because they can do more work. This model 9440 integrated circuit (IC) chip, dubbed the Microflame by Fairchild Camera and Instrument Corporation, is a 15-bit microprocessor capable of 10 million cycles per second (10 MHz). Its computing power is said to be as strong as so-called minicomputers built with TTL integrated circuits. Minicomputers are the bigger brothers of microcomputers in use by hobbyists. Microflame is a complete minicomputer central-processing unit on a 40-pin chip. Its memory capacity is 32,768 sixteen-bit words and its input/output ports can run 63 accessories. For more information, please circle number 150 on the reader-service card.

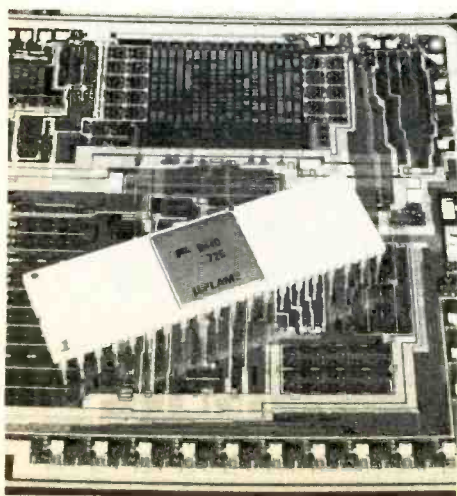

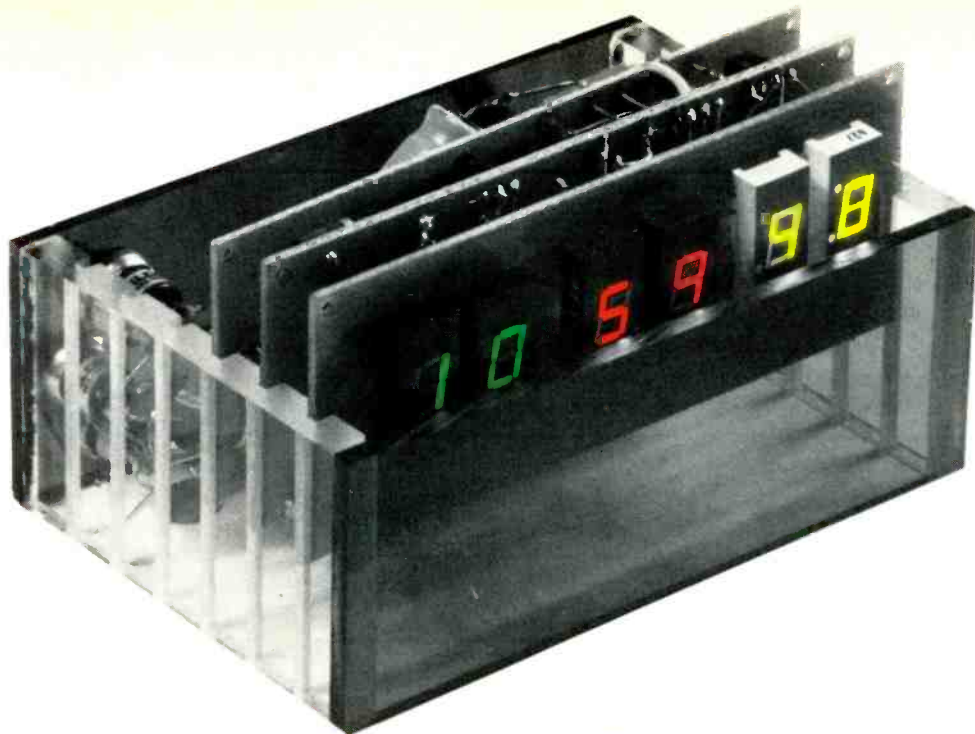

Modu-Clock: colorful in a rugged wrapper

Easy project number one for April is a flashy new digital-readout clock with pizzazz aplenty. Build this one tonight and watch the red, green and yellow numbers roll.

by Fred Blechman

The *Modu-Clock* is a versatile, multi-colored six-digit display electronic clock packaged in a seemingly indestructible extruded aluminum case. This space-age-looking decorator clock uses the popular MM5314 clock integrated circuit (IC) chip.

Your *Modu-Clock* can have 12 or 24-hour display. You can power it with 50 or 60 Hz ac using a 117-volt or 220-volt transformer, or with 12-volt dc using a simple crystal time base.

So, you can use it anywhere in the world as an accurate second-counting laboratory or house clock, a military clock, a rack-mounted time standard, or a studio clock/timer. Adding the inexpensive time base and an *enable display* wire, you can use it in an auto, van or

boat, running directly off 12-volt dc power.

Multi-colored displays

Although you can use any cabinet large enough to hold your *Modu-Clock*, the Logi-Case specified in the parts list is ideal. The outer shell is a deburred $3\frac{1}{4}$ -inch length of a one-eighth-inch wall, $4\frac{1}{2} \times 1\frac{3}{4}$ -inch rectangular cross-section aluminum extrusion—extremely strong but light.

The drawer is made of four one-eighth-inch thick pieces of plastic machined to slide into the shell. The front and back are different colors—

smoke and red. Since our display uses different colors, we picked the smoke-colored end as the front panel.

The sides of the Logi-Case drawer each have six machined vertical grooves. The inside dimension between the grooves is four inches—exactly the width of the printed circuit boards.

You can etch your own circuit board or use the boards offered in the parts list. If you etch your own, you can use a single, large board or cut it into three separate boards. These smaller boards can be mounted in the Logi-Case, or sandwiched together with screws, nuts and spacers into your own case. Con-

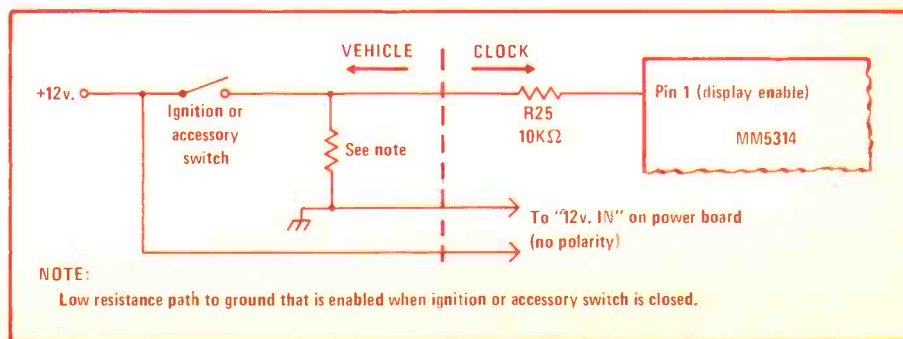

You can use your *Modu-Clock* in your car by adding a crystal time base as described in the text. Connecting the *Modu-Clock* to your car's electrical system as shown will kill the display when the ignition switch is off, but allow the clock to continue keeping time.

struction procedures described here assume you use three PC boards installed in a Logi-case with the specified transformer.

Power by ac or dc

The readout module holds six 7-segment 0.3-inch common-anode digits—your choice or red, green, yellow or orange. We used red for hours, green for minutes and yellow for seconds. The parts list contains a suggested source of these displays.

The clock module contains the clock IC, seven segment-driver transistors, six digit-driver transistors, biasing and current-limiting resistors, and a resistor and capacitor (R1 and C1) for multiplex timing.

The third PC board contains the power supply. When powered from dc, polarity is proper at the output of the bridge rectifier circuit regardless of the input polarity. So you can connect either input wire to the dc positive line.

Construction is straightforward. The first step is to decide whether the clock uses ac or dc, 12 or 24-hour display, 50 or 60 Hz timing pulse, display blanking or constant display.

For ac operation, mount the transformer on the back panel, inside the drawer. Any transformer similar to ours that provides at least 100 mA at 10 volts may be used. The three time-setting pushbutton switches (S1, S2, S3) also are mounted on the back panel.

Stuffing the boards

The PC boards are *stuffed* with a few parts at a time on the non-foil side. Mount the resistors first, then the transistors, the capacitors, and the diodes. The clock IC is last. Solder the leads on the foil side using small-tip 25-40 watt soldering iron and clip the excess wire. Use 0.031 60/40 resin core solder to reduce the likelihood of forming solder bridges across the gaps between the foil strips.

When inserting the displays into the readout board, be sure that pin 1 of each display is in the upper left hand corner of its display area. Pin 1 of each digit is the upper left hand pin when viewed from the front of the digit with the decimal points at the bottom. The top of the PC board is the edge *without* the 13 small holes.

If the 2000 ohm resistors R10 through R16 on the clock board are not small enough to fit between transistors Q7 through Q13, tilt the resistors up at the transistor end, or raise the transistors slightly off the board. The tops of the transistors should not be more than five-sixteenth-inch above the board.

The wide printed circuit path running down the center of the MM5314 area is circuit ground. If you want a 12-hour

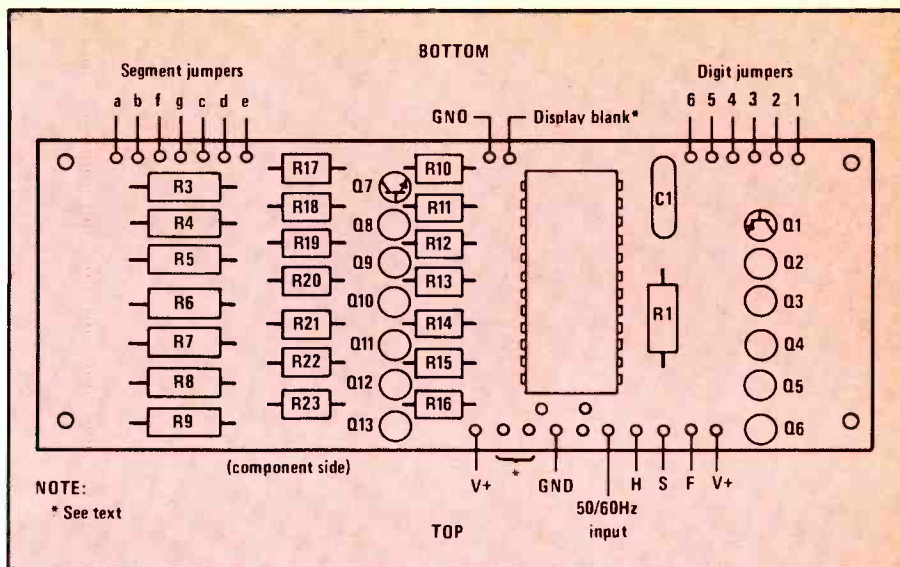

The clock board is stuffed with components as shown. Transistors Q1 through Q5 are each inserted into the board with their emitter, base and collector leads positioned as diagrammed in the Q1 symbol. Transistors Q7 through Q13 are each inserted as shown in the Q7 symbol.

display, jumper pin 10 of the 5314 to ground. Leave this pin unconnected for a 24-hour display. If you're going to use a 60 Hz input, jumper pin 11 to ground; leave this pin unconnected for 50 Hz input.

On the power board diode D1 must be mounted on the foil side of the power supply or it won't fit in the drawer slot.

Make sure the banded end (cathode) of each diode is as shown. Solder D1 between D2 and D4, with the cathode connected to the cathode of D4 and the anode connected to the cathode of D2. Don't overlook the wire jumper, which provides voltage to the digit display driver transistors. Capacitor C3 also mounts on the foil side of the board,

Modu-Clock parts list

Part number	Description	Price	Supplier
MC-2100A	PC Board Set	\$4.95/set of 3	REL Electronics
LC-2100A	Logi-Case	\$6.95	REL Electronics
R01, R02	Red .3" common anode LED display, Man-72	\$1.25 each	James
R03, R04	Green .3" common anode LED display, Man-52	\$1.00 each	James
R05, R06	Yellow .3" common anode LED display, Man-82	\$1.00 each	James
IC1	MM5314 digital clock integrated circuit	\$2.95	California Industrial
R1, R2	100K ohm 1/4W carbon resistor #271-1300	5/.39	Radio Shack
R3-R9	270 ohm 1/2W carbon resistor #271-000	2/.19	Radio Shack
R10-R16	2K ohm 1/4W carbon resistor #271-1300	5/.39	Radio Shack
R17-R23	10K ohm 1/4W carbon resistor #271-1300	5/.39	Radio Shack
R24	See text—voltage dropping resistor		
C1	.022 mfd ceramic disc capacitor	.06	James
C2, C4, C5, C6	.01 mfd ceramic disc capacitor	.05 each	James
C3	1000 mfd 15V electrolytic capacitor	.55	California Industrial
D1-D4	1N4001 silicon rectifier	.08 each	California Industrial
D5	1N4148 signal diode	.07	California Industrial
Q1-Q6	2N3906 PNP general purpose transistor	.15 each	California Industrial
Q7-Q13	2N3904 NPN general purpose transistor	.15 each	California Industrial
T1	10v transformer #DTT-1	\$1.95	California Industrial
S1, S2, S3	Normally open SPST pushbutton switch	3/\$1.00	California Industrial
Line Cord	2-conductor 6' power supply cord	.39	James
Miscellaneous;	screws, nuts, insulated and bare wire.		
	dc version		
All of above parts, except R2, T1 and line cord, plus the following:			
R25	10K ohm 1/4W carbon resistor #271-1300	5/.39	Radio Shack
TB	Time Base Kit #TB-1 or equivalent	\$4.95	Optoelectronics

Suppliers:

California Industrial, PO Box 3097M, Torrance, California 90503. Postpaid if transformer ordered. Otherwise add \$1 for shipping and handling. California residents add 6 percent sales tax.
 James Electronics, 1021-A Howard Avenue, San Carlos, California 94070. Minimum order is \$5 shipping postpaid. California residents add 6 percent sales tax.
 Optoelectronics, Inc., Box 219, Hollywood, Florida 33022. Add \$1.25 for shipping and handling. Florida residents add 4 percent sales tax.
 Radio Shack—over 6000 locations in 50 states and 9 countries.
 REL Electronics, 5220-A E. Donald Avenue, Denver, Colorado 80222. Add \$1 per order for postage and handling. Colorado residents add 6 percent sales tax.

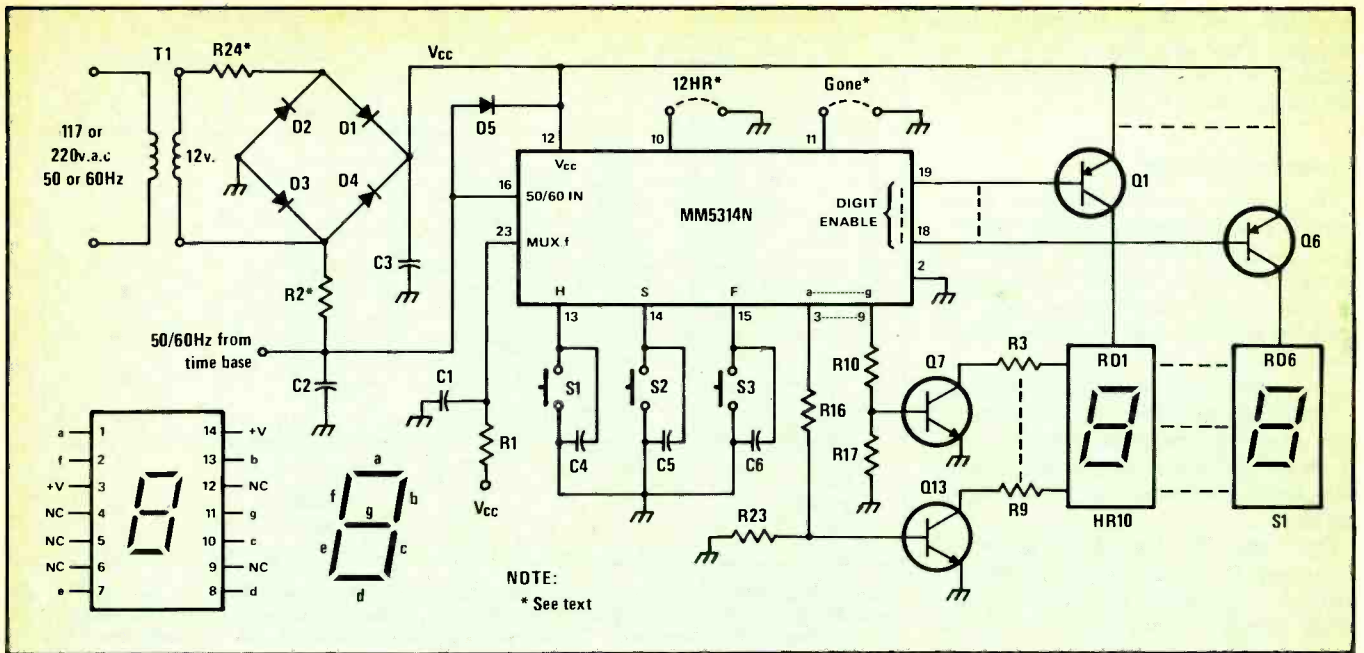

approximately as shown, to prevent interference with the transformer.

Insert the completed display board into the slot closest to the front panel, with the digits facing forward. Insert the clock module into the next slot, with the foil side facing forward and the 13 solder pads at the bottom, opposite the 13 solder pads on the display module.

Now join the two boards with 13 bare

wire jumpers, which can be salvaged resistor and capacitor leads clipped off after soldering. Seven segment-jumpers are on the lower left side, with six digit-jumpers on the lower right side. The holes and solder pads for these jumpers should be directly opposite and facing each other. Solder each end of the jumpers to the foil of the two boards.

Temporarily insert the power board,

foil facing the rear, into the next drawer slot. Locate and mark the area on this board opposite the three time-setting wire holes on the clock module.

Remove the power board and, using a fine saw or file, cut a notch in the board about three-sixteenth-inch wide and one-eighth-inch deep. This slot will be used later to pass through the time-setting wires to the rear-mounted switches. Re-insert the power board in the drawer, foil facing the rear. Solder four straight, bare jumper wires from the top of the power board directly across the clock board solder pads. Cut off the excess wire.

All that remains now is the switch and transformer wiring. Three wires go from the clock module to the switches—one to each switch. The other terminals of each switch are joined together by a single bare wire going to ground on the power board. A 0.01 capacitor is wired across each switch (C4, C5, C6) to eliminate jumpy time setting and false triggering by transient electrical signals.

Setting the time

The power cord passes through a one-quarter-inch diameter hole drilled in the rear panel, and is connected to the orange and gray transformer primary wires. Twist and solder the wires. Use heat-shrink insulation, or tape to cover the wires. The secondary leads of the transformer, yellow and green wires, are soldered directly to the 12 V in pads on the power board.

Plug the clock into a power outlet. The six digits should all light, probably but not necessarily displaying all zeros. The last digit should begin counting seconds. Measure the dc voltage across C3; it should not exceed 15 volts. If the voltage across C3 is higher than 15 volts, use a dropping resistor, R24, in series with the transformer secondary. The value of

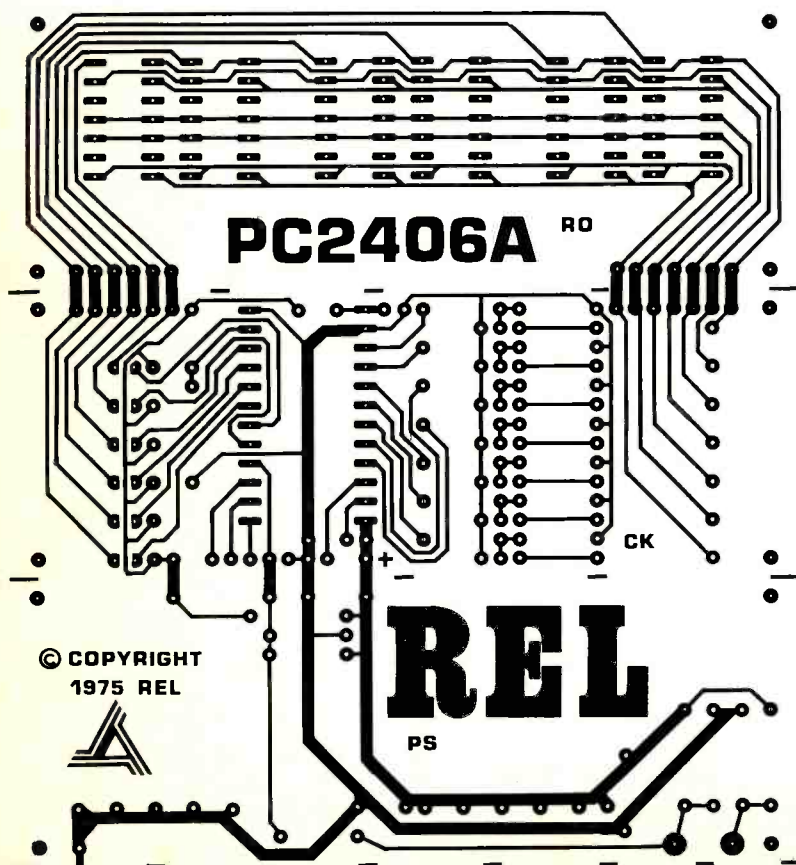

If you'd rather etch your own PC board, you can use this layout. If you're using your own case for the clock, you can leave the board as a single unit. If you want to use the Logi-Case, or sandwich the boards, cut the master board at the two cut marks.

Six steps for successful PC soldering

There's no question about it, using a printed circuit board makes circuit construction much, much easier than old-fashioned point to point wiring. But, if you're not careful, you'll find printed circuits also make it a lot easier to create *short* circuits. That's because it's so easy accidentally to leave a solder bridge between two adjacent foil strips.

Another problem you might encounter using printed circuit boards is a false connection—a solder joint that looks good, but is in fact no connection at all. This happens when only the component lead is heated. The solder forms a blob on the lead, which becomes insulated from the copper foil by rosin from the solder's core.

The trick to using printed circuit boards is to do a good job of soldering the component leads to the copper foil. It's really easy to do, if you'll follow these tips and take your time.

- Use a soldering iron designed for use on printed circuits. These are usually rated at 25 watts and have relatively small tips—perhaps a chisel point about 1/8th-inch wide.
- Use a top-quality electronic solder, which must be of the rosin core variety. Use the smallest diameter solder you can obtain.

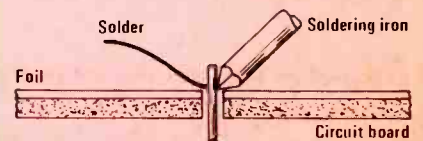

- Place the soldering iron tip on the copper foil and against the lead to be soldered. Apply the solder to the junction of the foil and lead on the side opposite the soldering iron.

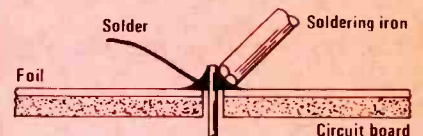

- When the foil and lead have been heated to the proper temperature by the soldering iron, the solder will flow onto the foil and lead like a drop of light oil.

- Remove the solder and iron. As the solder cools and hardens, it should appear smooth and it will shine.
- As you remove the soldering iron from the foil, lift it away. If you drag it away, you risk making a solder bridge across the gap to the adjacent foil strip.

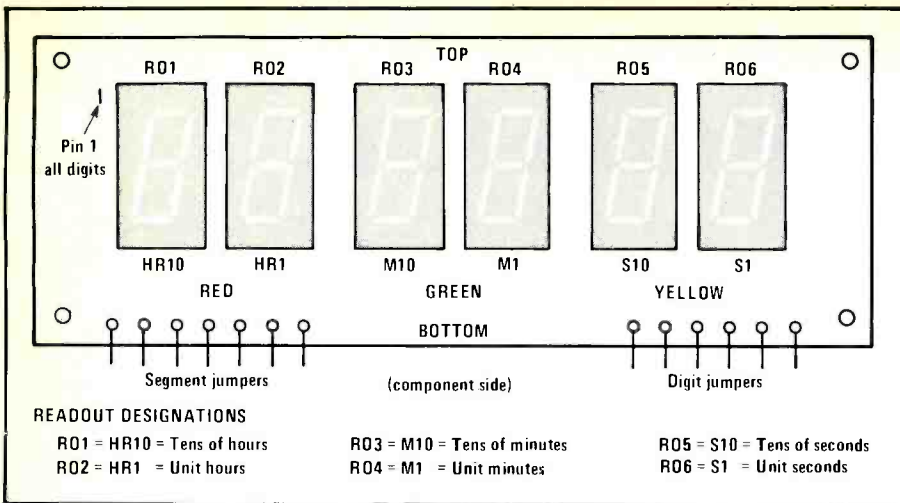

The readout LEDs are mounted on a PC board as shown. Looking at the board from the component side, the segment and digit jumpers attach along the bottom edge.

R24 should be about 10 ohms and 0.1 watt for each volt over 15 volts. For example, use a 50 ohm, one-half-watt resistor if the voltage measures 20 volts.

Setting the time is easy. The *fast* switch, S3, advances the time display one hour per second. The *slow* switch, S2, advances the minutes once per second. The *hold* switch, S1, stops all counting. Set the display slightly ahead of real time, as determined by phone company recording, WWV broadcasts or any other time standard, then press the *hold* switch until the real time catches up with the displayed time.

If you want to power your clock from 12 volts instead of a transformer, mount the time base on the rear panel. Connect its power leads to the power board positive and ground (across C3), observing polarity. The time base output, 50 or 60 Hz, is wired to the foil strip on the power board that connects R2, D5 and C2. Be sure to remove resistor R2 from the power board. Connect the 12 V in

pad on the power board to a source of 12-volts dc and your clock should light up and count.

When you operate your clock on dc, it's wise to *blank* the display to conserve power, and to make the clock less inviting a target for thieves in a dark, empty vehicle. To blank the display, connect pin 1 of the MM5314 to a ground or low-voltage point. Use a 10K resistor, R25, and a third wire connected to a point that has a low-resistance path to ground when no power is applied. The display appears when the ignition or accessory switch is turned on.

You can find this switchable voltage in your car at the fuse block by trial and error. Connect one input lead from the clock to an always on 12-volt point, and the other input lead to vehicle ground. Then testing with the third *enable* wire, find a place at the fuse block where the clock display is *on* when the car ignition switch is *on*. There are probably at least two places. Even when the display is off, the clock keeps counting time. ☐

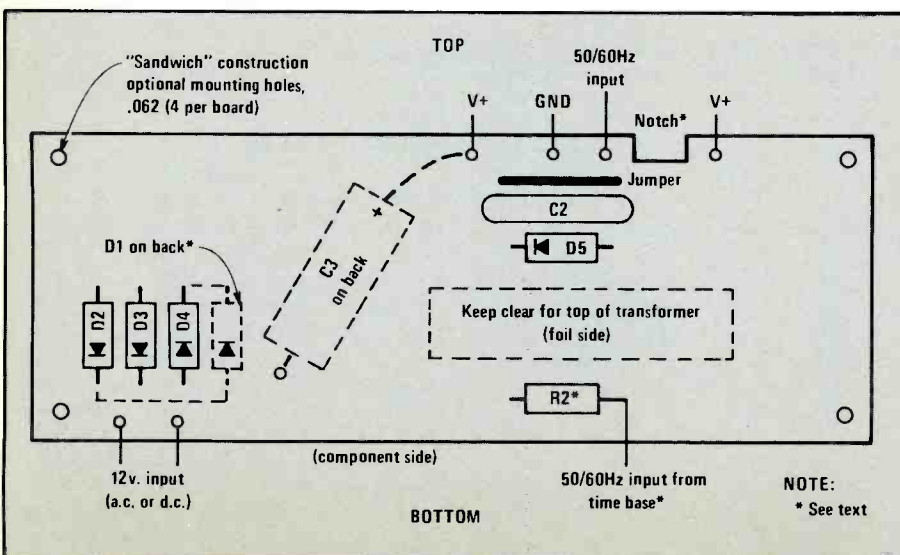

Components are mounted on the power supply board as shown. Note diode D1 and capacitor C3 are mounted on the foil side of the board. Make sure the area shown in dashed line above R2 in the diagram is kept clear of components.

Pocket scanners are portable fun

Here's a new and different way to carry a secret CB in your car without bolting it into the dash or trunk.



by Gerald R. Patton
Contributing Editor

Warning! Pocket scanners are not for everyone: only for those of us who don't yet own one....

The fact of the matter is that pocket scanners, tuned for public safety, amateur, or other radio services of interest, can be extremely informative, entertaining, and indeed essential for some people, such as certain public servants.

While talking to manufacturers during the preparation of our ME Buyer's Guide chart on pocket scanners, an interesting fact quickly came to light. Several firms who had previously made these units no longer do so. The reason for this is uncertain, but it can probably be attributed to the basic volatility of the

still-formative consumer communications market, which can keep even major manufacturers off balance (witness the current CB sales slump, for example).

In any event, we contacted five primary manufacturers who currently offer a total of fourteen different models covering various frequency bands. These frequency ranges include VHF low band (30-50 MHz), VHF high band (148-174 MHz), UHF band (450-470 MHz), and the UHF "T" band (470-512 MHz). Obviously, the model that's right for you depends in large part upon the frequencies that are active in your locality.

Those who, like myself, are ham radio operators and want to monitor the amateur radio two meter repeater sub-band (146-148 MHz) will want to know that, in general, any of these scanners that cover the VHF high band can also be used for the two meter band, although some peaking of the receiver may be necessary, particularly in order to enjoy maximum sensitivity on these frequencies.

How They Differ

Actually, except for frequency coverage, there are many more similarities among the scanners on our chart than there are differences. All offer four channel scanning with light emitting diodes as visual indicators of which channel is being received at any given time.

Some have channel lockout switches on all four channels, which enable you to have the scanner "skip" over a particular frequency, while the Fanon/Courier models and the Tempo MS-2 have a lockout provision on only one of the four channels. The lockout switch is very useful, for example, if you have a crystal for a National Weather Service frequency (162.55 MHz or 162.40 MHz) installed in your scanner. These stations broadcast weather reports 24 hours a day in many parts of the country. If you didn't have a way to turn this channel

off, your scanner would be locked up continuously on this frequency.

Inputs and Outputs

The scanners all have connections for an earphone (which typically mutes the internal speaker), external antenna (which can be used to greatly increase the coverage of the unit), external power, and battery charging (when Nicad batteries are used).

The Tempo MS-2, smallest of all the scanners listed, comes complete with "built-in" rechargeable batteries and a separate combination AC adapter/charger, so the charger and external power jacks are combined into one on this unit.

A unique accessory offered by Fanon/Courier for their scanners (Fanon models are tradenamed Scanfare, while Courier units use the trademark Cop-Scan) is the SCMA-1 mobile adapter. The scanner plugs into this adapter, which also serves as a mobile mount. It amplifies the scanner's audio output to 2.5 watts and delivers it to a large built-in speaker. The adapter provides operating and recharging power and also has an external antenna connector.

Auto or Manual

All of the scanners let you choose between automatic (scanning) operation or manual stepping to the frequency you want to monitor. Radio Shack's scan delay feature holds the unit on channel for approximately two seconds after the incoming signal ceases. In this way, if a reply is made within the hold time, the receiver is still tuned to that frequency. Otherwise, you might miss the reply because the scanner may have moved on and stopped on another frequency.

This feature is of more value when listening to units communicating directly with each other (such as a base station and a mobile) rather than stations talking through a repeater (an automatic

station located at a point of high altitude to receive and re-transmit FM signals for the purpose of greatly extending the range of relatively low power transceivers), whose carrier "tail" would usually hold the scanner on channel long enough for a reply message to be heard anyway.

Where to Find Them

Fanon/Courier and Bearcat units are marketed through electronics dealers across the country, while Radio Shack and Lafayette products are sold through their own dealer and mail-order network. The Tempo MS-2 scanner, along with a number of other unique miniature and sub-miniature FM receivers, are made for and distributed by the giant Los Angeles amateur radio dealership, Henry Radio.

These scanners represent some very sophisticated electronics squeezed into a tiny package. Whether you're a policeman, fireman, ham radio buff, or just an interested spectator of the drama of everyday human life, one of these portable "windows on the world" can keep you tuned-in to the action taking place in your area!

MAKE/ MODEL	PRICE CLASS	SIZE INCHES	WT. OZ.	FREQUENCY COVERAGE	NUMBER CHAN- NELS	LOCK- OUTS	JACKS	COMMENTS
Bearcat		2.75x6.25x1.50	11		4	4	Ant, Ear, Chg, Pwr	AC Adapter, Battery Chgr.
SP H/L	130			36-44 & 152-162				
SP U	130			450-470				
SP U/T	140			450-470 & 470-512				
Fanon/ Courier		2.90x5.60x1.40	13		4	1	Ant, Ear, Chg, Pwr	AC Adapter, Car Adapter, Mobile mount.
VHF	80			146-175				
VHFL	75			25- 54				
VHF-HL	100			30- 50 & 146-174				
VHFH-U	110			146-175 & 450-475				
UHF	75			450-475				
UHFH	75			475-512				
Lafayette								
Hi-U-100	120	2.90x6.50x1.40	9	148-174 & 450-512	4	4	Ant, Ear, Chg, Pwr	Available May 1978
Radio Shack		6.50x2.90x1.50	12		4	4	Ant, Ear, Chg, Pwr	AC Adapter, Car Adapter, Scan delay.
PRO-4A	100			148-174				
PRO-5A	120			450-512				
PRO-6	120			30- 50 & 148-174				
Tempo								
MS-2	100	2.75x4.50x1.25	7	140-170	4	1	Ant, Ear, Chg/Pwr	AC Adapter/ charger incl. Wire antenna, earphone incl. Nicads incl Flex ant extra.

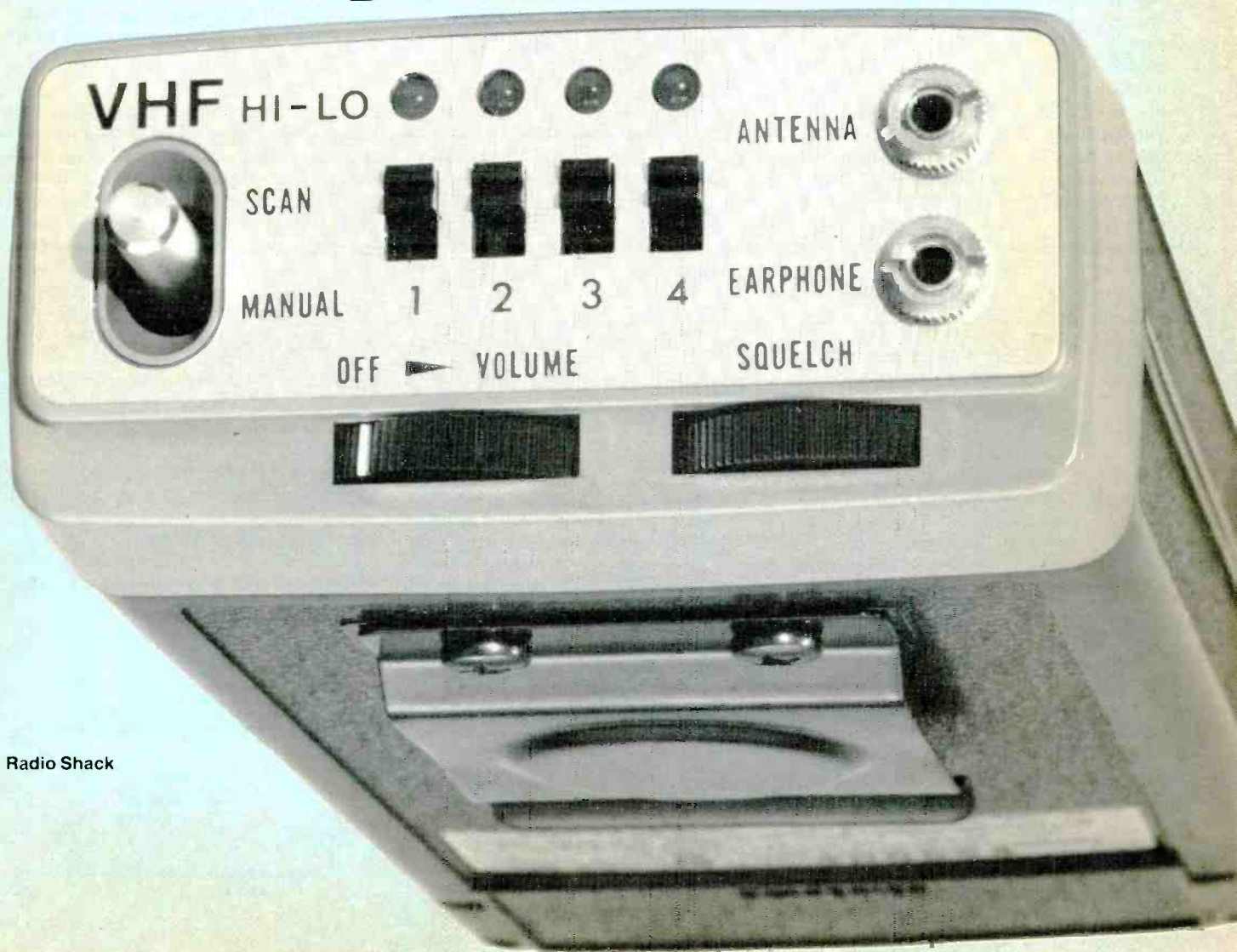

Radio Shack

Universal power supply

If you're into solid-state electronics, you need a good, reliable, low-voltage regulated power supply. Here's an inexpensive, easy to build universal supply that meets your needs with room to spare.



by Jeffrey A. Sandler
Contributing Editor

One of the handiest gadgets an experimenter can have is a regulated power supply, especially if it provides a switch-selectable choice of the voltages most often used. Here is just such a supply. Although simple to build, it provides a choice of five or 12 volts at up to one amp. Best of all, if you have a reasonably well stocked junk box, the supply shouldn't cost you more than a few dollars to build.

The heart of most low current power supplies built today is the solid-state voltage regulator chip. Contained in a molded package about one-half inch square and an eighth inch thick, these regulators maintain their rated output voltage to within 100 millivolts.

Choose your own

In actual operation, most regulator chips perform better than their specs. Typically, a 7805 can maintain its five-volt output to within 11 millivolts while the load current demand varies from 150 ma to over one amp. The 7812 typically can hold its output to within 17 millivolts

of its rated 12 volts over the same current range.

The power supply shown here uses the 7805 and 7812 regulators to provide a switch-selectable choice of five or 12 volts. But, if you prefer, you can substitute other regulators in the 7800 series to obtain different voltages. You also can use a double pole rotary switch and several regulators to provide a greater number of selectable output voltages. Listed below are the commonly available regulators:

Regulator number	Radio Shack number	Output voltage
7805	276-1770	5
7806	—	6
7808	—	8
7812	276-1771	12
7815	276-1772	15
7818	—	18
7824	—	24

The 7800 series regulators all require at least two volts greater input voltage than the rated output, even during the low point of the input ripple component. All

of the regulators, except the 7824, will operate with dc inputs of up to 35 volts. The 7824 will handle inputs of up to 40 volts.

Use your own

If you have your own unregulated dc supply, you can convert it into a regulated supply by adding only the 7800 series regulators to the output. All you need do is make certain the output of your supply is well filtered and at least *two volts greater* than the regulated output you want.

If you don't already have a dc supply, you may have a transformer, diodes and filter capacitors in your junk box. You can use just about any power supply circuit you'd like. However, the basic dc supply circuit shown in the schematic will work well, and uses readily obtainable parts.

The power supply shown is built into a Radio Shack cabinet. You can build your supply in just about any enclosure you have laying around. Parts layout is not critical. The only requirement beyond using good construction practices is that

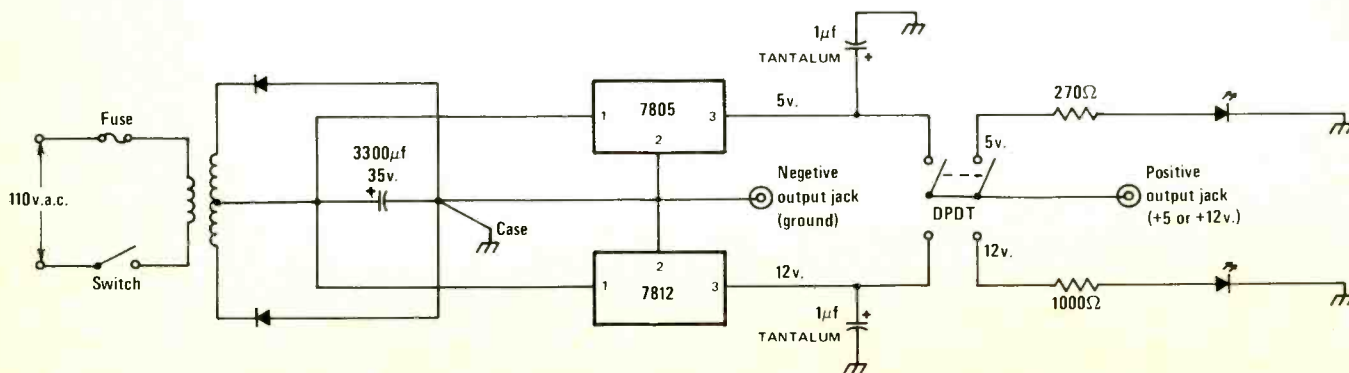

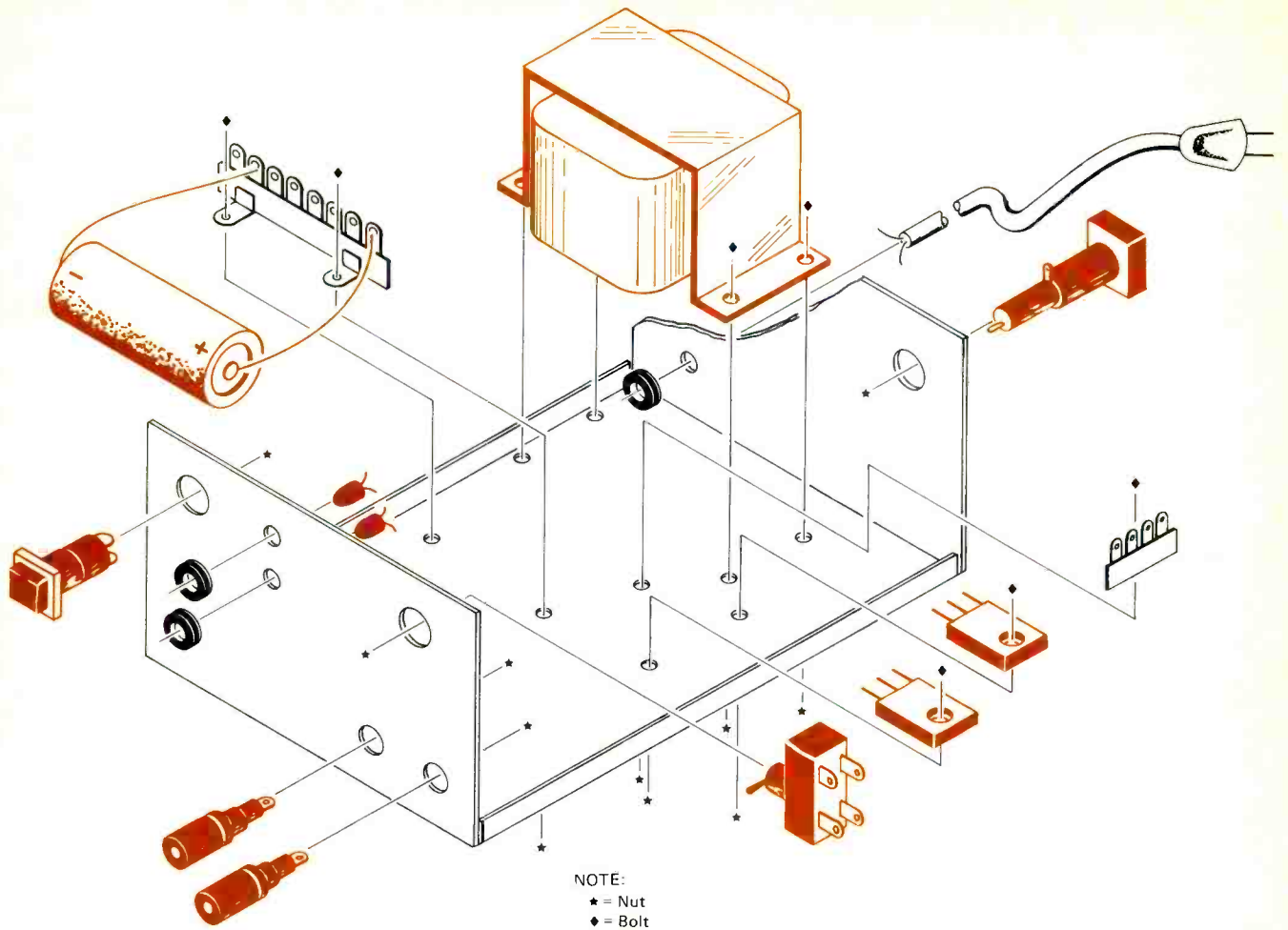

the 7800 series regulators be mounted directly to the chassis or be otherwise heat sunk.

The LED voltage indicators can be replaced by a voltmeter, or eliminated. If

you do leave out a voltage indicator, make sure you label the switch positions in large, easy-to-read lettering.

Operation of the regulated supply is straightforward. Just connect the circuit

to be powered to the output connectors, and turn on the supply.

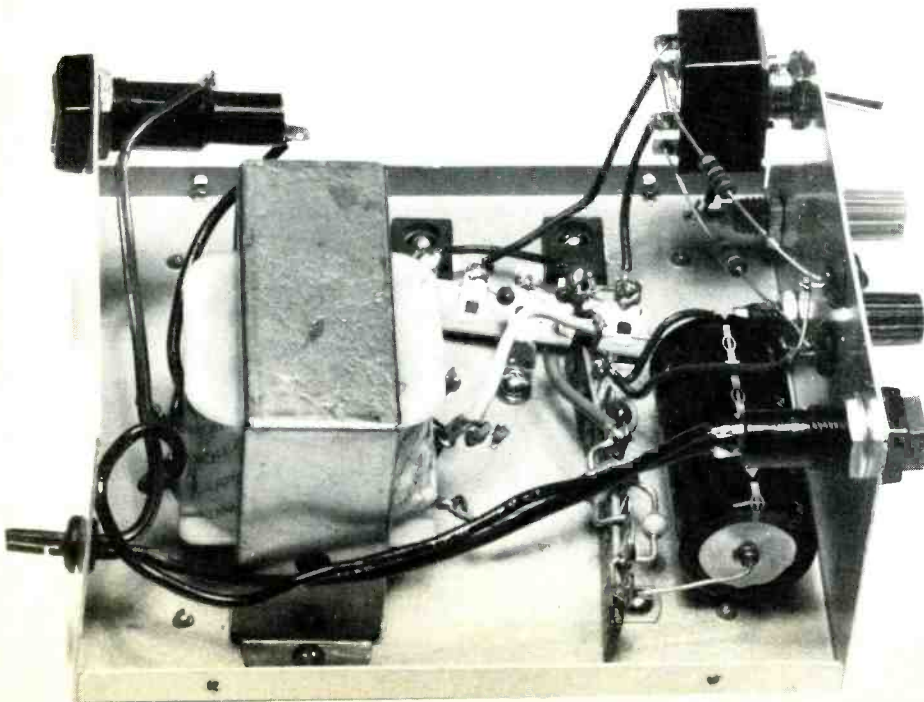

Component	Radio Shack number
Resistor, 270 ohm	271-016
Resistor, 1000 ohm	271-023
Capacitor, 3500 mfd @ 35 V	272-1021
Capacitors (2), 1 mfd tantalum	272-1406
7805 regulator	272-1770
7812 regulator	272-1771
LEDs (2)	276-041
Transformer, 25 V CT @ 2 A	273-1512
SPST on-off switch	275-617
DPDT toggle voltage switch	275-666
Fuseholder	270-365
Fuse, 1/2 amp slow-blow	270-1282
Terminal strip, 5 terminal	274-688
Terminal strip, 8 terminal	274-692
Binding posts (2)	274-662

In addition, you'll need miscellaneous hardware, a case or chassis, line cord and strain relief to complete the supply. Radio Shack part numbers are given because of their availability in small quantities. All of the parts can be obtained from mail-order parts supply houses as well.

All of the 7800 series regulators have built-in current limiting. Even if you should accidentally short the output leads, the output current will be held to a level the regulator can safely handle. While this will protect your power supply, it won't protect the circuit being powered.

Insulators and capacitors

Electricity is the flow of electrons in a circuit. That's why such circuits are called **electronic**. Like water in a pipe, electricity can be made to flow in only one direction in a circuit. Or its **polarity** can be switched back and forth, alternately changing the direction of flow.

We call that one-way flow **direct current**.

The rapidly switching two-way flow is called **alternating current**.

direct current - **dc**

alternating current - **ac**

Insulators

1. Rubber
2. Glass
3. Mica
4. Paper
5. Wood
6. Plastic
7. Ceramics
8. Air
9. Others

Many materials are composed of **atoms** with a firm grip on their electrons. If such atoms don't allow electrons to flow easily, we think of the materials as **insulators**.

Even the air we breathe is a **poor conductor**. Materials which are non-conductors are called **insulators**.

Copper wire, on the other hand, is a good conductor since copper atoms require very little electromotive pressure to make electrons flow.

Conductors

1. Copper
2. Steel
3. Others

Steel also is a good conductor but requires more push to get electrons to flow. It is not as good a conductor as copper.

Why don't electrons spill out of wall sockets ?

The electric company puts 120 volts pressure into copper wires to your house. We find the flow of electrons they have generated at electrical outlets or wall sockets.

Non-conductors vs. poor conductors

There are no true nonconductors. What we call insulators really are poor conductors. With extremely high voltage pressure, so-called non-conductors can be made to carry an electron flow.

Air is an insulator between the two sides of an outlet. That prevents current flow. But air is not always an insulator.

When a force of millions of volts builds up between sky and ground, it's large enough to send a bolt of electrons along the cloud-to-Earth circuit. Every insulator has a break down voltage beyond which it will start to conduct electricity.

handbook

Storage cans for electricity

A capacitor is one component in an electronic circuit. Think of it as two conductors separated by an insulator.

The conductors are called **plates**. Their size and spacing determine the amount of electrons you can store in a capacitor. That is, what its **capacitance** is.

microfarads - μfd
picofarads - pf

Farads

We label the amount of capacitance as **farads**. The more capacitance, the more farads. Electronic circuits normally require only tiny amounts of capacitance, below one farad.

Common values of capacitors are in millionths of a farad or **microfarads**. Even smaller amounts are **pico farads**.

Roadblocks to dc

Electrons flow through a circuit from one capacitor plate to the other. If there is only a one-way flow, as in dc, the capacitor quickly is charged to full capacity and no more current flows. The capacitor is a roadblock to dc.

On the other hand, as the direction of electron movement switches back and forth, as in ac, current can continue to flow.

Capacitors permit ac current to flow while blocking the flow of dc current.

OSCAR

continued from page 31

an increment of 28.7362° per orbit, and an inclination of 101.7010°.

For more information about the educational program write the ARRL at 225 Main St., Newington, Conn. 06111. For more about when, where and how to listen to OSCAR, write ARRL or the Radio Amateur Satellite Corp. (AMSAT), Box 27, Washington, D.C. 20044. AMSAT is an international organization of hams and listeners interested in amateur satellite work. It sponsors the satellites and coordinates activities.

OSCAR Earth stations need not be in houses. Fred Merry, W2GN of East Greenbush, N.Y., makes contacts through OSCAR while driving his car. Dick Long, WA4JID of Plantation, Fla., talked with hams from on board his sailboat while on an ocean trip down through the Florida Keys.

Sun-revitalized batteries

OSCARs are powered by rechargeable nickel-cadmium (nicad) batteries, revitalized by the sun through solar cells on the satellite skins. OSCAR 7 has many cells so its power supply is strong. OSCAR 6, with fewer solar cells, was turned off periodically to conserve energy. Now it's off permanently with dead batteries.

OSCAR 6 had only one rebroadcaster on board. It was only capable of hearing signals in the two-meter ham band and retransmitting them on the 10-meter amateur band. OSCAR 7, on the other hand, has two repeaters aboard. One day it hears the two-meter band and retransmits on 10 meters. The next two days it hears signals at 432 MHz in the 70-centimeter band, and retransmits them to Earth in the two-meter band. Shortwave receivers hear only the 10-meter band, not two meters, so OSCAR 7 can be heard with a simple receiver only every third day. OSCAR 7 signals on two out of three days coming down on two meters can be heard by hooking a converter between antenna and receiver. Converters start at \$40. OSCAR 8 also has two repeaters on board.

When to listen

A sure-fire way to hear OSCAR is turn on a shortwave receiver. OSCARs pass overhead at least twice during an evening.

Select the band on the receiver for coverage of the 10-meter ham band. Set the dial at about 29.5 MHz. Turn on the receiver's "BFO" or turn a "mode" switch to "CW" or "code" or "SSB" position. When an OSCAR satellite passes overhead or near your location you'll be able to hear at least the stronger signals coming through.

OSCAR 6 was designed for one year of life. However, it lasted five years. OSCARs 7 and 8 also will be in orbit for years. And AMSAT is building a new generation of OSCARs to extend communications time.

These Phase III satellites will have kick motors to push the satellites into elliptical orbits, taking OSCAR as far out as 20,000 miles over the Northern Hemisphere Earth stations for up to 12 hours and out of sight behind the Earth only about one hour. The ability of hams to help out in emergencies and natural disasters, transmit medical data or locate downed aircraft will be even greater.

Phase III birds will give hams around-the-clock abil-

ity to talk through space satellites to England, Russia, China and the whole northern half of the world.

The first Phase III satellite is under construction now. It is expected to fly late in 1979. A second Phase III bird may go up a year later.

Amateur radio operators in the USSR plan to launch their own OSCAR into orbit this year. Known as the RS OSCAR, the satellite will be in orbit about 590 miles high. OSCAR 8 is about 560 miles up. Since RS OSCAR and OSCAR 8 are closer to Earth than OSCAR 7 at 900 miles, they will take less time to complete one circle around the globe. Their periods will be about 103 minutes or about 12 minutes faster than OSCAR 7. OSCAR 8 and RS OSCAR will complete 14 revolutions per day compared with about 12½ for OSCAR 7.

With RS and 8 at lower altitudes, hams using the communications satellites will have slightly shorter range available. You can make contacts through OSCAR 7 with amateurs as far as 4900 miles away. With OSCAR 8, range is reduced to about 4000 miles since the bird doesn't look down on quite as large an area of the Earth's surface at one time. The Phase III ham satellites of the 1980s, however, promise 12,000 miles range!

So dust off your shortwave receiver. Hang out a wire antenna. Cock an ear toward OSCAR. You might hear WA4JID on the ocean, W2GN in his car, EKGs from California, hurricane bulletins from Florida, G3IOR completing an extraordinary 6000-mile conversation with W6CG, or even my station, K3RXX, as I talk with new states and countries. There's plenty of excitement when you ride along the ham satellites. 

TAB POPULAR CB BOOKS

CB Radio Operators Guide—2nd Edition

Tells what CB is, how it is used, how to buy and install equipment—PLUS Part 95, the FCC rules regulating CB. 256 pps.

Order No. 799 Paper \$5.95 Hardbound \$8.95

Practical CB Radio Troubleshooting & Repair

Complete details on CB operation, installation and repair, including 21 programmed troubleshooting charts and complete schematics for 18 popular transceivers. Also an in-depth section on antennas and feedlines. 238 pps.

Order No. 754 Paper \$5.95 Hardbound \$8.95

Pictorial Guide to CB Radio Installation & Repair

Step-by-step guide to car and base systems installation and basic maintenance. 256 pps.

Order No. 683 Paper \$5.95 Hardbound \$8.95

Citizens Band Radio Service Manual

All-in-one troubleshooting and maintenance guide for all types of CB sets, including a 36-page schematic foldout section. Step-by-step repair procedures and trouble-analysis charts. 192 pps.

Order No. 581 Paper \$5.95 Hardbound \$8.95

ORDER FORM

Modern Electronics
14 Vanderventer Avenue
Port Washington, NY 11050

Ship the books listed below. To cover shipping, I've added 50¢ for the first book and 25¢ for each additional book. Enclosed \$

No.	Price	Name _____
_____	_____	Address _____
_____	_____	City _____ State _____ Zip _____

Cruise control: make tumpike driving fun again

Add this convenient cruise control to your car. Eliminate cramped legs on long trips and save gas mileage to boot. An expensive option to buy from the factory, this easy add-on makes long distance driving less tiring.

by Ron Cogan
Contributing Editor

The most common complaint voiced about driving on long trips is the constant pedal pressure that must be applied to keep a steady speed.

There is a way to all but eliminate one-third of the work involved in driving long distances. With the addition of a sophisticated cruise control, you can forget about future attacks of throttle-foot fatigue and simply concentrate on watching the road and negotiating curves.

The cruise control maintains a steady speed for you over long stretches at highway speeds. You have to manually control the gas pedal during in-town driving and at slower speeds. This option is especially helpful for motorists who undertake extra-long trips since the steady stretches are the most boring and hardest on the right foot.

Cruise controls are available from many manufacturers nationwide and fall into two distinct categories: *vacuum operated* and *electronic*. For the most part, the devices that operate on the vacuum principle are more involved and require either dealer installation or a very diligent do-it-yourself approach. On the other hand, the electronic *Pacesetter* system we installed as an example is designed for an easy at-home hook-up. Directions are straightforward and very few parts are involved.

The first step in installing this system

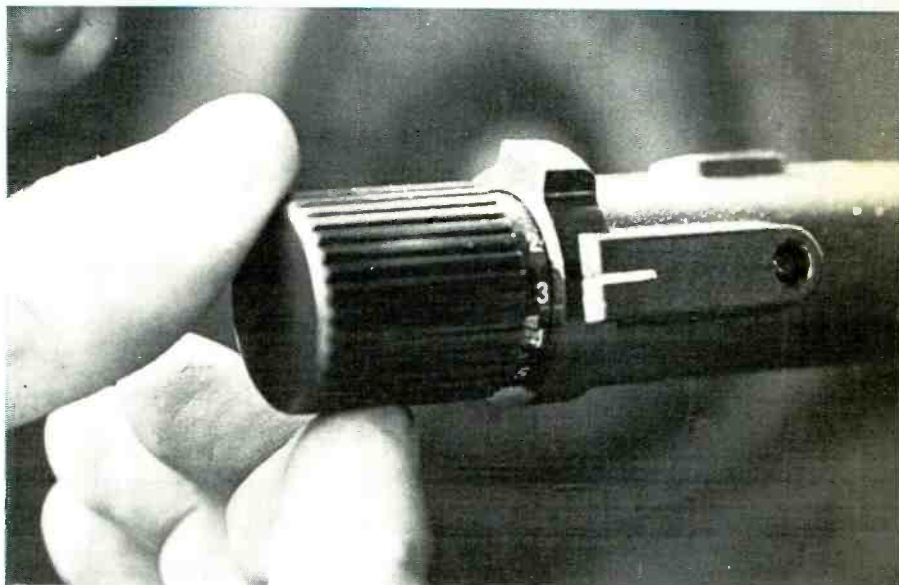

It's easy to set your automatic cruise control mounted on the turn signal lever. With a flick of the switch and a quick adjustment of the Pacesetter's speed control knob, you'll be eliminating fully one-third of the work involved in driving. You'll save with fuel economy and no longer will have to watchdog the speedometer to keep within legal speed limits.

is to place the servo in your engine compartment. The servo's cable will pull and release the throttle and must be placed so it pulls the throttle straight back. Keep this in mind when determining a likely mounting location for the servo and cable assembly.

Under the hood

When you have found the most likely spot to mount the servo, double-check to make sure your cable can easily reach the throttle arm. It must lay in a smooth loop without sharp bends. You can snake it around obstacles such as hoses, wiring, and brackets, but be sure it doesn't touch any hot or moving parts of the engine. Line the servo up in position, mark mounting holes, drill, and attach securely with hardware provided. The servo can be positioned in many ways for correct operation *except* upside-down, with the servo arm on top.

With the servo cable already routed to the carburetor area of the engine, you

should attach the hooked end of the cable to the throttle arm, and then attach the plastic cable tab securely to a non-moving part in the engine compartment. This keeps the cable itself from moving as the servo pulls the throttle arm and ensure that the pull on the arm is as straight back as possible.

The idea behind the spring clip connection is to attach it so it pulls the throttle linkage all the way from *hot idle* to *full throttle*—just short of your passing gear. The servo is designed to pull the cable a maximum of 1¼ inch—therefore the cable must be attached at a place where a 1¼ inch pull will cause the engine to progress from the hot idle to full throttle range.

If the 1¼ inch specification is not met, the vehicle will have a tendency to surge—losing speed going up hill and gaining speed going down hill. A handy measurement chart and more detailed instructions on this part of the installation is included in the Pacesetter's owner's manual.



First step is to locate a mounting spot for the servo in your engine compartment. After adjusting the movable mounting brackets and determining the best location, mark reference points for drilling mounting holes.

Mounting controls

The controller should be mounted next. Since the controller in the Pacesetter III system must be attached to your car's turn signal lever, your first step is to prepare the lever for the installation. Most levers have a decorative knob on the end which prevents the controller from being slipped into place. Some of these knobs can be unscrewed and removed, while others are permanently attached and will have to be hacksawed off. Try to unscrew the knob by gripping it tightly and turning counterclockwise. If your efforts prove futile, you'll have to grab a hacksaw and do it the hard way. Smooth off any burrs or sharp corners with a file.

Slip the controller's mounting collar and nylon sleeve onto the turn signal lever, then the controller itself. Make sure that the controller's operating light is facing you and the *engage* button is pointed up; then attach the controller permanently on the lever using the mounting collar and sleeve following the directions.

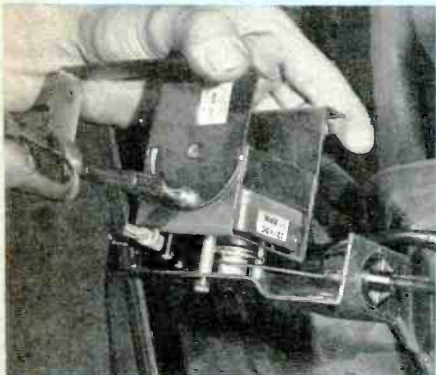

The movable arms on the servo must be securely tightened prior to installation.

The wiring harness from the controller should either be run inside your steering column housing or glued neatly along the outside of the housing and routed to an area under the dash. Special quick-dry glue is provided for this purpose.

The electronics package comes next. Take a look at the driver's side of the firewall in your vehicle to locate a suitable spot for the package, preferably one that's high enough to be out of view and away from potentially-damaging feet. Also, this is an ideal spot because the component is within reach of the wiring connectors from both the servo and controller. The unit should be secured to the firewall with the self-tapping screws supplied.

The wiring harness from the controller (which you've left dangling under the dash near the steering column) should now be plugged into the electronics package. Next, drill an access hole through the firewall inside the engine compartment to allow the



After the holes have been drilled, the servo should be mounted securely in position using the four sheet metal screws provided.

servo's wiring harness to be routed to the electronics package; then plug it in. Finally, the system's power harness should be plugged onto the remaining terminals. The Pacesetter's directions outline which connectors should be plugged to the three different terminals to eliminate any errors.

Color-coded connection

Five color-coded wires are included in the power harness for easy reference during connections. The *red-and-white* striped wire and the *gray* wire must be routed through the access hole in the



firewall and run into the engine compartment. Connect the red-and-white wire to the positive battery cable, and the gray wire to the distributor side of your coil, which is usually marked DIST.

If you have the new General Motors high energy ignition (HEI), the gray wire must be connected to the solid brown wire coming from the bottom of the distributor to the distributor cap. In Ford electronic ignition systems, the gray wire must be connected to the



Carefully route the servo's throttle cable to the throttle linkage near the carburetor. This cable can be gently curved around noses and other engine components, but avoid sharp bends that might restrict cable movement.

green-and-yellow striped wire coming from the coil.

An extra Scotch-lok connector is included in the system's installation kit to facilitate these connections. For Chrysler electronic ignitions, the gray wire goes on the distributor side of the coil, the same as in any other standard installation. Pacesetter's manufacturer should be contacted for specific instructions when an installation is being performed on a vehicle equipped with non-factory electronic ignitions or CID.

Three wires are left now in the power harness—red, black, and blue. The black wire is ground and must be grounded to a bare-metal spot on the car's frame or dash. The red wire should be connected to your heater's blower fuse at the fuse box. This is an accessory that is only hot when the ignition switch is in the on position. Crimp the connector clip supplied in the kit to the stripped end of the red wire, and then clip the wire to the left-hand side of the blower fuse.



Drill an access hole through your firewall for the servo's wiring harness. Several other wires from the cruise control's electronics package also will be routed through this hole to the engine compartment.

Finally, the blue wire should be connected to the cold side of your brake light switch, which should be located at the end of the brake arm inside the firewall of the car. The wire that runs from the brake light switch to the battery is the hot side, while the wire running from the switch to the brake lights is the cold side you'll be tapping into.



Feed the wiring harness through the hole so the end will reach the electronics package you'll be mounting inside. You might want to install a rubber grommet in this hole or wrap the wiring with extra electrical tape to prevent the metal edge from fraying the wire later.

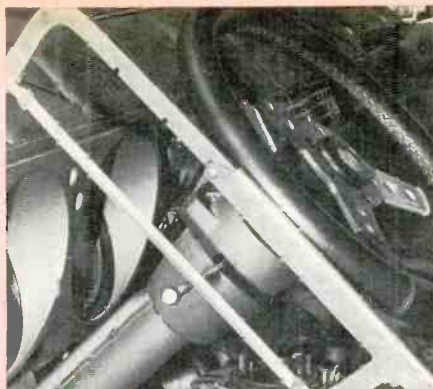

The Pacesetter III system we're installing utilizes a controller that mounts to your turn signal lever. Try to remove the lever's decorative knob by twisting counter-clockwise. If this doesn't work, you will have to saw the end of the lever off with a hacksaw. Use a file to remove burrs or jagged edges.

Now it's time for a test to make sure that everything is working properly. Start the car with the transmission in neutral and the parking brake on, then switch the Pacesetter selector to on and turn the speed knob to 1. The engine should rev up and down when the engage button is pushed. If it continues to rev up, then the gray wire on the coil is on the wrong side.

After it has revved up and down a few times, tap the brake; the system should disengage and your engine should return to a normal idle. If it does not disengage, check to make sure that your brake light is functioning properly and the blue wire is securely connected.

With your gearshift in neutral or park and the Pacesetter turned off, race the engine for a moment. Then, lift your foot off the accelerator. If the engine does not return to normal idle—if it continues to race—the spring clip is



catching on something. This should be corrected before actually taking the vehicle on the street for some field testing. If the engine returns to normal idle when you lift your foot off the accelerator, you are ready for the road test.

Take your car to a highway where 55 mph is a proper and legal speed. Speed up to 45 mph and set your speed adjustment knob at a safe, low level (usually

about 3 on the dial), and turn the system on. Hold your foot on the accelerator for a few seconds and turn the dial slowly until you feel the system take over the operation of the throttle.

Note the number on the speed adjustment knob and correlate that with your actual miles per hour. Now vary the speed, up and down, and note the relationship between the dial setting and the speed of your vehicle. You will quickly learn which dial setting to turn to for a desired road speed. Drive for a few miles with the system on whatever

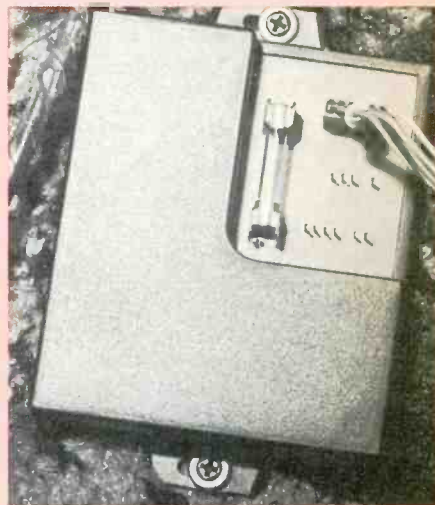

Determine a mounting location for the system's electronics package. This should be placed at a spot where both the servo and controller wiring harnesses will be able to reach, as well as out of the way of potentially damaging feet and moving cab components. We found the best location to be on the upper section of the firewall inside the cab.

dial setting you feel comfortable with. The system should maintain a constant speed—within one or two miles per hour—the entire way, uphill or down.





























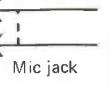







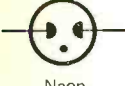



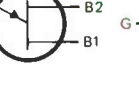



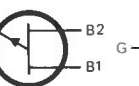









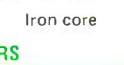

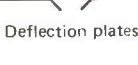







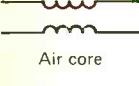
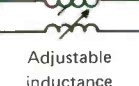
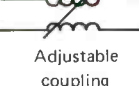











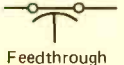
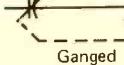

Now, tap the brake pedal to make sure the system disengages. You should immediately feel the cruise control let go of the throttle cable and your speed begin to drop. If it does not do this, either the spring clip is hanging up on something, the brake light is not working correctly, or your brake light connection to the blue wire is faulty.

That's all there is to it! You now have an efficient, electronic cruise control at work for you. Over the next few trips that involve some heavy miles, you may want to make a note of your gas mileage so you can compute the exact savings in miles per gallon that's being achieved because of the steady throttle pressure. And unless you possess a throttle foot that can maintain an absolutely steady pressure throughout a trip, you will see your gas mileage increase.

Additional information on the Pacesetter system (\$89.95) may be obtained by contacting Annuncionics, Inc., Dept. ME, 2205 Stoner Avenue, Los Angeles, CA 90064.

Electronic symbols

as used in Modern Electronics magazine

 <p>A = Ammeter V = Voltmeter mA = Milliammeter</p> <p>* Insert appropriate designations</p> <p>METERS</p>	 <p>MOTOR</p>	 <p>Single cell</p>  <p>Multicell</p> <p>BATTERIES</p>	 <p>Chassis</p>  <p>Earth</p> <p>GROUND</p>	 <p>Aerial</p>  <p>Loop</p> <p>ANTENNA</p>	 <p>HEADSET</p>	 <p>CRYSTAL</p>
 <p>Coaxial receptacle</p>  <p>Coax plug</p>  <p>Female</p>  <p>Male</p>  <p>230v.</p> <p>CONNECTORS</p>	<p>CONTACTS</p>  <p>Phone plug</p>  <p>Phone jack</p>  <p>Phono jack</p>  <p>Mic jack</p> <p>CONNECTORS</p>	 <p>Shielded wire or coaxial cable</p>  <p>General</p>  <p>Enclosure</p>  <p>Enclosure</p> <p>SHIELDING</p>	 <p>AND gate</p>  <p>OR gate</p>  <p>Inverter</p>  <p>Other</p> <p>LOGIC</p>			
 <p>Neon</p>  <p>Pilot</p> <p>LAMPS</p>	<p>N-channel</p>  <p>D G2 G1 S</p> <p>N-channel</p>  <p>D G S</p> <p>N-channel</p>  <p>D G S</p> <p>N-channel</p>  <p>D G S</p> <p>P-channel</p>  <p>D G2 G1 S</p> <p>P-channel</p>  <p>D G S</p> <p>P-channel</p>  <p>D G S</p> <p>P-channel</p>  <p>D G S</p> <p>PNP</p>  <p>C B2 B1 E G</p> <p>NPN</p>  <p>C B2 B1 E G</p> <p>DUAL-GATE MOSFET</p> <p>MOSFET</p> <p>JUNCTION FET</p> <p>UJT</p> <p>BIPOLAR</p> <p>TRANSISTORS</p>	 <p>Amplifier</p>  <p>Operational amplifier</p>  <p>Other</p> <p>LINEAR INTEGRATED CIRCUITS</p>				
 <p>Ferrite bead ring</p>  <p>Air core</p>  <p>Tapped</p>  <p>Adjustable</p>  <p>Plug in</p>  <p>Iron core</p> <p>INDUCTORS</p>	 <p>Grid</p>  <p>Plate</p>  <p>Deflection plates</p>  <p>Heater or filament</p>  <p>Indirectly heated cathode</p>  <p>Cold cathode</p>  <p>Gas filled</p> <p>ELECTRON TUBE ELEMENTS</p>	 <p>Photoemissive (LED)</p>  <p>Zener</p>  <p>Diac (SCR)</p>  <p>Triac</p> <p>DIODES</p>				
 <p>Air core</p>  <p>Adjustable inductance</p>  <p>Adjustable coupling</p>  <p>Iron core</p>  <p>With link</p> <p>TRANSFORMERS</p>	 <p>Triode</p>  <p>Pentode</p>  <p>Voltage regulator</p> <p>COMPLETE TUBES</p>	 <p>SPST</p>  <p>DPDT</p>  <p>SPDT</p> <p>RELAYS</p>				
 <p>Electrolytic</p>  <p>Fixed</p>  <p>Variable</p>  <p>Feedthrough</p>  <p>Ganged</p> <p>CAPACITORS</p>	 <p>Fixed</p>  <p>Adjustable</p>  <p>Tapped</p>  <p>Adjustable</p> <p>RESISTORS</p>	 <p>SPST</p>  <p>Rotary</p>  <p>SPDT</p>  <p>Push-Pull</p> <p>SWITCHES</p>	 <p>No connection</p>  <p>Terminal</p>  <p>or</p>  <p>Connection</p> <p>WIRING</p>			



Marine electronics

a world on the waves

Radios, depth sounders, distance logs, wind speed indicators, radar. Electronics and boats go together like saltwater and taffy. Here's everything you ever wanted to know about electronics afloat in '78.

by Bob Margolin
Assistant Editor

I eased off on the sheets and let the boat nose into the wind. Eyeing the digital depth-sounder readout, I flicked the radio to channel 28 and called the marine telephone operator. My friend, on the other end of the landline call, pointed out that National Weather Service was broadcasting a high-wind warning.

The telltales flapping from my shrouds would have verified the report if the electronic wind gauge hadn't been closer at hand. Should I break out the fish finder and relax? Or heed the warning from my on-board radar that a storm was nearby?

The answer was easy. I left a resigned sigh with the fish and gull-winged it homeward.

Whatever your little joys in life are, one thing's for

sure. You can't in this age get away from electronics. If sailing over the waves is your relaxation to get away from it all, you probably still take along enough electronic gear to sink a native outrigger.

For most boat owners, the first thought after buying their boat is, "I've got to get a radio." It's hard to imagine modern boating without on-board radio. You need it to check for storm warnings, contact marinas for fuel and supplies, communicate with other boats, and even to send and receive ship-to-shore telephone calls. And if tragedy strikes, to call the Coast Guard for help.

Most pleasure boat owners aren't *required* to have a marine radio. Because of this, many boats are equipped with CB radio. While CB radio is useful on



The Sentry II Oxygen/Temperature Monitor by Ray Jefferson lets you know if the waters you're fishing are likely to be inhabited by fish. Although a good reading won't guarantee the presence of fish, a bad reading virtually guarantees their absence.

inland waters and in harbors where its short range is acceptable, it's not a substitute for marine radio.

Boats for hire that can carry six or more passengers are required to have a marine radio installation. These so-called *compulsory* installations are inspected every year by the district FCC office to see that they work.

VHF marine radio

Marine radio operation falls into three general classifications: line of sight, coastal waters, and high seas. Line-of-sight operation is the workhorse of marine radio. Operated in the 156 to 162 MHz band, vhf marine radio is *the* pleasure boat owner's radio service.

Every boat with a marine radio, whether a compulsory or voluntary installation, must have a vhf set aboard. The FCC simply will not license any other kind of marine radio without a vhf radio on board.

The vhf marine band is divided into 55 channels. Channel 16 is set aside for distress, safety and calling use only. The Coast Guard, in fact, monitors channel 16 24-hours a day, seven days a week.

Most vhf marine radios on the market have 25-watt transmitters, many with a switch-selectable one-watt output option for local ship-to-ship communications. With only a few exceptions, these radios are crystal controlled, requiring a separate transmit and receive crystal for each channel used.

Crystals cost

Although the average boat owner may use as many as 14 of the available channels, most vhf radios are sold with two to five channels installed. Most, however, also have at least one NOAA weather receiving channel as well.

Adding more channels to your radio can be an expensive proposition. The crystals used in most radios will cost you between \$5 and \$10 each, and you'll need two per channel. So, to crystal up 12 additional channels on your radio could cost you \$200 or more.

Depending on how many channels you expect to use, you may be better off buying a *synthesized* radio, which has all the vhf marine channels built-in. Although they do cost more to buy, you won't have the expense of adding crystals to your radio to get more channels.

Most vhf marine radios work off 12-volt electrical systems. If your boat has a 24 or 32-volt system, you'll need an adapter. You can also get an adapter to run your radio at home from the ac line.

Don't forget the antenna

If you're adding a radio to your boat, you'll also have to install an antenna. Boat antennas are different from car antennas because most boats have no built-in ground plane. And while the metallic body of an automobile makes a good ground plane for mobile antennas, your boat's wood or fiberglass body does not. So, you'll need an antenna that doesn't require a ground plane.

Virtually all vhf marine antennas work well without additional grounding, but there are a few designed for installation on steel vessels. Make sure the antenna you buy will work on your boat.

Coastal and high seas radio

When you go shopping for your vhf radio, you'll see quite a few *single sideband* (SSB) radios. These are medium wave (mf) radios used on vessels that normally operate 50 miles or more from shore.

Single sideband marine radios run up to 150 watts, and operate in the 2 to 3 MHz *coastal* band, and the 4 to 22 MHz *high seas* band. Most pleasure boat owners will be using the coastal band. The emergency channel monitored by the Coast Guard is 2.182 MHz.

Depth 160 feet, range...

Perhaps more common than radio on board pleasure boats is sonar. Sonar, which stands for sound navigation and ranging, can be used to measure the depth under your boat, or to find the distance and bearing of another boat or object in the water.

Sonar works by injecting a sound pulse through a submerged transducer into the water. When the pulse strikes the bottom or an object, some of the sound is reflected back to the transducer. Electronic circuitry built into the sonar measures the time, to a millionth of a second, the pulse used to make the round trip, and converts it into distance.

Scanning sonars electronically sweep the water in all directions on a horizontal plane around your boat. Using sonar, you can locate unseen hazards such as submerged wrecks and reefs, shorelines, piers, buoys, and other boats. You can even locate schools of fish.



The Seatron Mark X autopilot is one of the easiest to operate. All you have to do is set the desired course bearing, and push the *system on* button. The lack of additional controls makes the Mark X ideal for the weekend sailor who wants operating simplicity.



Digital depthfinders, such as this Datamar Kodiak, give you the depth in numerical form, saving you the trouble of interpreting a calibrated scale and flashing light. The Kodiak not only gives you the depth in feet, but at the flip of a switch, in meters or in fathoms.

Virtually all scanning sonars use cathode ray tubes (CRT) to indicate both distance and bearing from your boat to the object detected. These CRTs are very similar to those used as radar scopes. Because of the complexity of the circuitry used, sonars are expensive, generally more than \$2000.

How deep is the ocean

First cousin to the scanning sonar is the depth finder, which is really just a non-scanning vertical sonar. A sound pulse is beamed down to the sea floor beneath your boat. The time required for the echo to return is electronically converted to depth and displayed on an indicator.

Although just as accurate as the scanning sonar, depth finders can only tell you about whatever is under your boat. So, you can't use your depth finder to warn you of a sudden change in depth, such as a submerged wreck.

This Apelco flasher chart recording depth sounder is typical of the wide assortment of combination units you'll find at your marine electronics store. The curved-line trace provided by the recorder is more difficult to interpret than straight-line tracings. However, these recording depthfinders are less expensive than the straight line models.



Selected vhf marine radios

Model#	Two-way channel capacity	Weather channel capacity	Price
Apelco, 676 Island Pond Rd., Manchester, NH 03103			
AF-12	10	2	\$400
Benmar Div., Cetec Corp., 3000 W. Warner, Santa Ana, CA 92704			
1200	12	1	495
2400	24	1	650
Bristol Electronics, Inc., 651 Orchard St., New Bedford, MA 02744			
CH500	12	1	500
Epsco Brocks, 411 Providence Hwy., Westwood, MA 02090			
Seavoice	12	1	665
Gem Marine Products "Gemtronics", 356 South Blvd., Lake City, SC 29560			
GT-25	12	1	400
GT-25/55	55	2	500
GT-5500	55	4	800
GT-5510	55	4	850
General Aviation Electronics, Inc. "Genave", 4141 Kingman Dr., Indianapolis, IN 46226			
MM-12	12	3	340
MM-55-75	55	3	600
Icom East, Inc., 3331 Towerwood Dr., Dallas, TX 75234			
M-25	25	4	—
Inmar Electronics And Sales, Inc., Box 370, Oneonta, NY 13820			
seaTel-12dx	12	2	435
seaTel-55dx	55	2	500
seaTel-76/h	76	4	860
Intech, Inc. "Mariner", 282 Brokaw Rd., Santa Clara, CA 95050			
M-12	12	optional	440
M-20	12	1	380
M-70	55	4	595
M-76	15	2	500
ITT Decca Marine Inc., Box G, Palm Coast, FL 32037			
STR-25	57	2	1095
Konel Corp., 271 Harbor Way, S. San Francisco, CA 94080			
KR-28VN	12	2	540
VHF-780	78	3	895
Micro Marine, Inc., 2234 Micro Place, Escondido, CA 92025			
3100	13	2	850
Modar Electronics, Inc., 1301 East Algonquin Road, Schaumburg, IL 60196			
Triton	12	1	590
Triton Portable+	4	0	410
Triton 55/75	55	4	985
+ 1 watt power output			
Pathcom, Inc., 24105 South Frampton Avenue, Harbor City, CA 90710			
Pace M152	6	3	375
Pace M5200	13	3	335
Pace M5600	78	2	700
+ 2.5 watts power output			
Pearce-Simpson, 4701 N.W. 77th Avenue, Miami, FL 33166			
Bimini 25A	12	2	350
Bimini RT	12	2	390
Capri 25	12	2	420
Capri 55	55	2	680
Ray Jefferson, Main & Cotton Streets, Philadelphia, PA 19127			
1025	12	2	430
1425	12	2	460
5525	71	2	700
Raytheon Marine Company, 676 Island Pond Road, Manchester, NH 03103			
Ray 48A	12	2	400
Ray 50A	55	4	895
Regency Electronics, Inc., 7707 Records Street, Indianapolis, IN 46226			
Aqua-Com I+	5	1	300
AquaPhone*	6	2	220
MT-25	12	2	30
MT-55	55	2	670
+ 4 watts power output *17 watts power output			
Simpson Electronics, Inc., 2295 N.W. 14th Street, Miami, FL 33125			
1200	12	2	400
12-2	12	2	495
55	55	2	680
Sonar Radio Corp., 73 Wortman Avenue, Brooklyn, NY 11207			
2308-	5	0	550
+ 2 watts power output			
Standard Communications Corp., Box 92151, Los Angeles, CA 90009			
SR-C 830S	5	0	370
Horizon 25	12	2	440
Horizon 78	55	4	750
+ 3 watts power output			
Tele Comm Communications, Box 3232, Margate, NJ 08402			
VHF25M	10	0	595
VHF25M55	55	0	900
Texas Instruments, Box 6080, Dallas, TX 75222			
Ti2000	55	4	795
Unimetrics, Inc., 123 Jericho Turnpike, Syosset, NY 11791			
Sea Hawk 25	12	2	290
Sandpiper 2500	14	2	350
Sea-Com 78	78	4	600
International 1080	108	4	700

Unless otherwise noted, all radios listed provide 25 watts of transmitter output and operate from 12 volts dc.

But, they're ideal for navigating a channel and avoiding sandbars or other gradual changes in the bottom. And while they won't tell you about a school of fish 100 yards off the port bow, some will let you know when you're directly over one.

Flashers are common

Depth finders are classed according to their readout indicators. There are depth finders with flashing lights, with digital displays, with old-fashioned meters, and with chart recorders. To a large extent, the cost of a depth finder depends on the kind of readout it has.

Flashers are the most common, and usually least expensive, fast action depth finder. A lamp, mounted on the edge of a slowly rotating disc, passes behind a calibrated depth scale. Each time the lamp passes zero feet, a sound pulse is injected into the water.

After bouncing off the bottom, the pulse returns to your boat, and the lamp flashes. The time the pulse took to make the trip is the same time it took the lamp to travel along the dial calibration to the actual depth beneath the boat. If you see

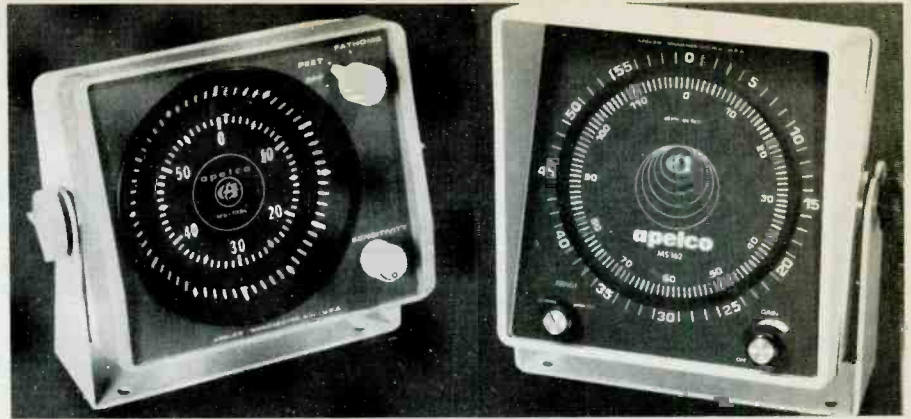

These Apelco depthfinders are typical flasher units. The MS-138L, on the left, is single range, dual scale instrument that gives you depth soundings up to 60 feet or, at the flip of a switch, 60 fathoms. The MS-162, on the right, provides a choice of 60 or 120 feet depth limits, but doesn't provide readings in fathoms. Other flasher units provide readings only in feet to a single depth limit.

some rapid blinks several feet above a more sustained flash, you're over a school of fish.

Digital and analog

Digital depth finders work in a similar manner, but instead of lighting a lamp, the time is electronically converted into

feet and displayed as a number. While it's much faster to read a number than to watch for a flashing light, digital depth finders generally can't be used as fishfinders.

Analog meter readouts are the least expensive depth finders, but are very slow acting. They're used almost exclusively as navigational aids when reading charts.

Chart recorders give you an inked paper graph of the terrain beneath your boat, not just an average depth as do the other types. And they graphically indicate the presence of fish. Most chart recorders are built into depth finders that have a flasher or digital readout. A few, such as the Seatron Professional and the Ross Sportsman Straight Line Recorder, are self-contained units that provide only a chart recording of the depth.

Another kind of fish finder

While depth finders and sonars give an accurate indication of fish, there is another, less expensive fish finder—the oxygen indicator. Fish require from five to 13 parts per million (ppm) dissolved oxygen in the water. Since fish can't live where there's less oxygen than this, there's little point in fishing waters lacking this oxygen level.

Oxygen monitors measure the dissolved oxygen in the water and display the reading in ppm. Although the monitors can't guarantee the presence of fish, they do let you know when you're in waters that can sustain fish.

Some monitors, such as Ray Jefferson's \$120 Sentry give you only the dissolved oxygen measurement. Others, such as the Sentry II, also give the water temperature. So, if you limit your fishing to areas with the right oxygen level and the right temperature, your chances for success are excellent.

Although beyond the means of most pleasure boat owners, radar can be worth its weight in gold. At night or in fog, radar can warn you of other boats

Selected single sideband marine radios

Brand	Power output	two-way channel capacity	Price
Communications Associates, Inc., 200 McKay Road, Huntington Station, NY 11746			
SSB-125	125	24	\$2000
CA-35MS-20	150	20	6210
CA35MS/MK II	150	40	7500
ITT Decca Marine, Inc., Box G, Palm Coast, FL 32037			
SSB-150	150	24	2645
R.L. Drake Company, 540 Richard Street, Miamisburg, OH 45342			
TRM-1	150	12	1430
General Aviation Electronics, Inc., 4141 Kingman Drive, Indianapolis, IN 46226			
GSB-1000	60	10	795
Inmar Electronics and Sales, Inc., Box 370, Oneonta, NY 13820			
SeaTel-ssb 100	100	10	1600
Intech, Inc. 282 Brokaw Road, Santa Clara, CA 95050			
Mariner M-500	75	8	1045
Mariner M-1500	125	23	1500
Mariner M-1600	150	24	2250
International Radiotelephone, Box 600, Kent, WA 98031			
RT-1200	100	14	1600
RT-1250	150	24	2000
Konel Corporation, 271 Harbor Way, South San Francisco, CA 94080			
SSB-1022	130	22	1200
KR-100SB	100	17	1600
Maritek, Inc., 1819 South Central Avenue, Kent, WA 98031			
SB6-80	80	6	800
SB6-100	100	6	1095
M6100	100	12	975
M6150	150	12	1075
Micro Marine, Inc., 2235 Micro Place, Escondido, CA 92025			
Offshore 100	100	11	1500
2100	125	12	2000
Modar Electronics, Inc., 1301 East Algonquin Road, Schaumburg, IL 60196			
Triton SSB	125	24	2410
Northern Radio Company, 14975 N.E. 40th Avenue, Redman, WA 98052			
N-570	100	11	1500
N-550	150	12	2500
Raytheon Marine Company, 676 Island Park Road, Manchester, NH 03103			
RAY 1210	50	8	750
SGC, Inc., 220 Airport Boulevard, Watsonville, CA 95076			
SG-711-MF	70	11	875
SG711	100	11	1200
America One	150	24	1500
InterContinental	150	36	2500
Seatron, 4312 Maine Street, Philadelphia, PA 19127			
SSB-100	100	10	1400
Tele Comm Communications, Box 3232, Margate, NJ 08402			
WA150SSB	110	10	1500

Depth finders: flashers,

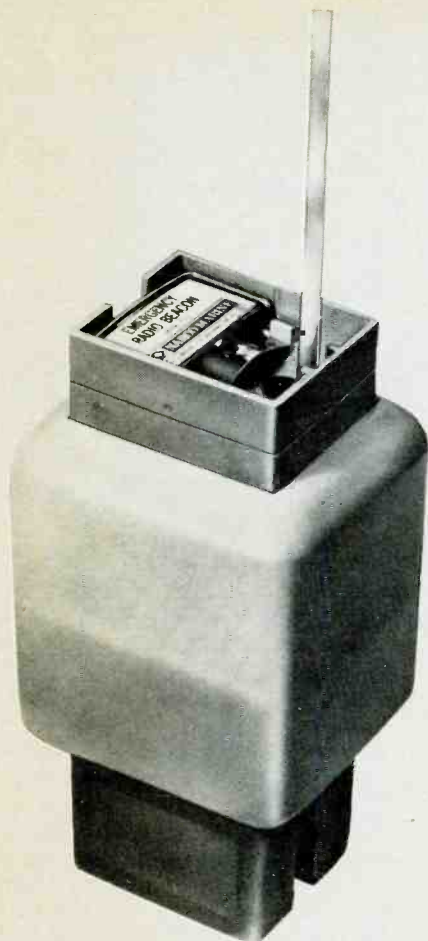

Emergency position indicating radio beacons, or EPIRBs, such as this NARCO MRB 510 transmit on 121.5 and 243 MHz, typically for 7 days, while floating in the water. The signal can be detected by search and rescue airplanes 100 miles or more away.

and hazards above the surface that you wouldn't otherwise see.

Radar works in a manner similar to sonar. A radio frequency pulse is transmitted from the antenna. If the pulse strikes an object, some of the pulse is reflected back to the antenna. The returning pulse is displayed as a blip of light on a radar scope calibrated in distance. Looking at your scope, you can tell how far away and in what direction the object is, and its relative size and shape.

In addition to warning you about other boats and hazards, you can use your radar to determine your location. By observing the contour of the shoreline on your scope and comparing it to your charts, you can pinpoint your location.

Loran and you

If your main interest in radar is locating your position, Loran can do the job at less than one-quarter the price. Loran is a network of government-run coastal transmitters. Special receivers on board your boat compute and display your location based on Loran signals received

Model	Depth range in ft.	dc voltage required	Price
-------	--------------------	---------------------	-------

Depth finders with flasher readout

Apelco, 676 Island Pond Road, Manchester, NH 03103			
MS 160	60	12	\$150
MS-138L	360	12	200
Aqua Meter Instrument Corp., 465 Eagle Rock Road, Roseland, NJ 07068			
36300	100	12	140
Compact	200	12	195
36600	360	12	195
Benmar Division, 3000 West Warner, Santa Ana, CA 92704			
D1-16	100	12	130
FF-17	360	12	200
D1-19	720	12/24/32	360
Coastal Navigator, Inc., 17711 15th Ave., NE, Seattle, WA 98155			
DS-050	50	12	100
DS-200	200	12	145
DS-606	360	12	225
Compass Electronics, Box 366, Forest Grove, OR 97116			
Sensi-Depth 3	60	12	190
Sensi-Depth 4	120	12	130
Sensi-Depth 6	200	12	150
Danforth, 500 Riverside Industrial Parkway, Portland, ME 04103			
T202	200	12-24/32	230
T204C	200	12/12/32	375
Epsco Brocks, 411 Providence Highway, Westwood, MA 02090			
Seafarer 3	360	12 to 40	185
Fishfinder	360	12 to 40	185
Garcia Corp., 329 Alfred Road, Teaneck, NJ 07666			
9260A Portable	60	12	135
9350 Hi-Speed	100	12	165
Gemtronics, 356 South Boulevard, Lake City, SC 29560			
GT-1011	150	12	200
GT-660	360	12	160
Heathkit, Benton Harbor, MI 49022 (build-it-yourself kits)			
MI-1030	240	12	60
MI-1031	240	12	90
Inmar Electronics, Box 370, Oneonta, NY 13820			
Sea-Trac 100	100	12	175
Sea-Trac 7070	420	12	200
Ray Jefferson, Main & Cotton Streets, Philadelphia, PA 19127			
511	100	12	120
521	200	12	150
5700	420	12	190
Lowrance Electronics, 12000 East Skelly Drive, Tulsa, OK 74128			
LFG-175	100	12	108+
LFG-360	180	12	218+
LFG-460	360	12	306+
+ All units require additional extra-cost transducer.			
Pearce-Simpson, 4701 N.W. 77th Ave., Miami, FL 33166			
Dolphin 101	100	12	100
Dolphin 360	360	12	160
Raytheon Marine Co., 676 Island Pond Road, Manchester, NH 03103			
DE-123	120	12	170
DE-738L	360	12	240
DE-726B	720	12/24/31	640
Ross Laboratories, Inc. 3138 Fairview Ave., E. Seattle, WA 98102			
Sportsman T100-B	100	12	245
Sportsman DR-300B	300	12/32	425
Fisherman DR-600C	600	12/32	800
Sea Deep International Corp., 633 Revell Highway, Annapolis, MD 21401			
SD-100	100	12	130
SD-200	200	12	200
SD-400	400	12	190
Sears, Roebuck, Sears Tower, Chicago, IL 60684			
59551	100	12	80
59565	200	12	120
59562	360	12	160
Simpson Electronics, Inc., 2295 N.W. 14th St., Miami, FL 33125			
F-100	100	12	105
60	360	12/32	190
Sonar Radio Corporation, 73 Wortman Ave., Brooklyn, NY 11207			
D-1010	60	12	145
D-1021	100	12	170
D-1020	200	12	160
Techsonic Industries, Inc., One Humminbird Lane, Eufaula, AL 36027			
HBT60	60	12	150
HBT100	100	12	150
WP200	200	12	240
Unimetrics, Inc., 123 Jericho Turnpike, Syosset, NY 11791			
High Speed 600	60	12	190
High Speed 1200	120	12	150
High Speed 3600	360	12	190
Depth finders with digital readouts			
Bristol Instruments, Inc., 651 Orchard St., New Bedford, MA 02744			
DD1240	99	12	130
DD1200	199	12	290
Coastal Navigator, Inc.			
DDS-99 Digital	99	12	300

meters, charts and digitals

Datamarine International, Inc., Commerce Park Road, Pocasset, MA 02559			
Datamar 100D	99	12	230
M-200D Capree	199	12	250
2650 Kodiak	999	12	479

Electro Marine Systems, Inc., 96 Fox Hunt Lane, E. Amherst, NY 14051			
RSD	120	12	330

Heathkit (build-it-yourself kit)			
MI-101	200	12	150

Kenyon Marine, Box 308, New Whitfield St., Guilford, CT 06437			
DS-300	300	12	400

Narco/Andrews Instruments, 9033 Monroe Road, Houston, TX 77061			
DS330	360	12	310

Ray Jefferson			
201	200	12	260

Raytheon Marine			
DE-750	360	12	470

See Deep International			
SD-1	299	12	300

Signet Scientific Company, 3401 Aerojet Ave., Elmonte, CA 91510			
Mark 70	100	12	365
Mark 71	500	12	470

Depth finders with meter readouts

Apelco			
MS-162	120	12	170

Electro Marine Systems			
U25D	60	12	160
VSP	120	12	220

Pearce-Simpson			
Dolphin 100	100	12	140

Raytheon Marine			
DE-737A	100	12	220

Depth finders with chart recorders

Apelco			
MR-201C	360	12	320

Agua Meter Instrument Corp.			
380	600	12	450

Epsco Brocks			
Seascribe II	600	12 to 40	700

Garcia Corporation			
9400AF	240	12	425

Gemtronics			
GT 1202S	480	12	480
GT 1202D	960	12	550
GT-1056	1440	12/24/32	1000

Heathkit (build-it-yourself kit)			
MI-2910	600	12	290

Inmar Electronics			
Sea-Trac 480R	480	11 to 40	550

Konel Corporation, 271 Harbor Way, South San Francisco, CA 94080			
FG-200A	288	12	650
FG-11A	960	12	735
FE-500	1800	12/24/32	1300

Lowrance Electronics			
LRG-1510	240	12	480
LRG-610A	360	12	600

Ray Jefferson			
5300	300	12	350
5600	585	12	450
5800	540	12	550

Raytheon Marine			
DE-731	2400	12/24/32	1890

Ross Laboratories			
Sportsman DS-300B	300	12/32	710
Fisherman DS-600C	900	12/32	1245
Fine Line 200-B	1200	12/32	2450

Sears, Roebuck			
59547	100	12	470

Simrad Inc., One Labriola Court, Armonk, NY 10504			
Skipper 701	420	12 to 32	595
EY	1080	12	1345

Smiths Industries, Inc., Box 5389, Clearwater, FL 33518			
SI-TEX HE31	1440	12/24/32	645
SI-TEX HE 103B	1700	12/24/31	1150

Sonar Radio Corp.			
DC-1024	240	12	300
DC-1048	480	12	360

Telisons International Corp., 7075 Vineland Ave., N. Hollywood, CA 91605			
AS-100STC	780	12	460
TS-1301	840	12	660
TS 1303	1680	12	700

Unimetrics, Inc.			
White Line 500	480	12	450
White Line 960	960	12	550
Straight Line 1000	1000	12	650

from a pair of coastal stations. Most Loran receivers are accurate to within a fraction of a nautical mile.

If the \$1500 or so price tag of a Loran receiver is beyond your means, there's still another location aid you can use—the radio direction finder, or RDF. The Pearce-Simpson Islander, for example, covers six bands, yet costs only \$150.

Finding your way

RDFs are very similar to the multi-band radios you can buy from Panasonic, Sony, Radio Shack and others, but with the addition of a sensitive directional antenna. Usually mounted on the top of the case, the antenna can be turned compass-style over a 360 degree circle.

As you turn the antenna, the received signal suddenly will drop in strength. The bearing of the antenna at this *null* point is the bearing from your boat to the station being received. If you know the location of several shore stations, you can triangulate your position from the bearings you've taken.

Most RDFs provide only a line bearing. They do not, however, indicate whether the station is in front of or behind the antenna. This doesn't present any problems if you're triangulating, but if you're steering toward a *single* station, you could find yourself heading out to sea.

Raytheon and other manufacturers offer automatic direction finding equipment that gives you a true bearing on a compass-like indicator. But, Raytheon's Navimatic RDF will cost you about \$1500, the price of a Loran receiver.

They've even got calculators

Knowing where you are is only half the battle. You also have to know how to get where you want to go. For the weekend sailor, navigation is a real problem. How many hours or minutes should you sail south southwest before changing course to west northwest, for example.

Tamaya's NC-2 Astro-Navigation Calculator can give you this kind of

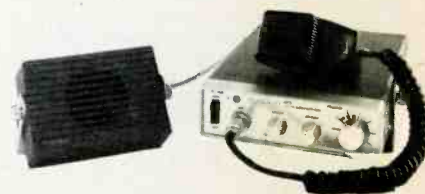

The Apelco AF12 vhf marine radio is one of the smallest 25-watt units available. Measuring just two inches high, seven inches wide and 9 inches deep, the AF12 has 10 two-way channels plus the two NOAA weather receive-only channels.

course, speed, and time information as fast and easily as any pocket calculator you've used to solve simple arithmetic problems.

At \$175, it's within the reach of almost all boat owners. The Coast Navigation School, 418 E. Canon Perdido, Santa Barbara, CA 93102, is the U.S. distributor. They also offer home-study courses in navigation built around the NC-2 for \$130 and \$235 each.

Lazy man's helmsman

If you do a lot of boating, spending many hours at sea, you may find an autopilot more of a necessity than a luxury. An autopilot, which keeps your boat on a predetermined heading automatically, will free you from the wheel so you can get in your fishing or maintenance work, or catch some sleep. Its value is more apparent if you're the only experienced mariner aboard.

Autopilots come in a variety of sizes, shapes, and cost. You can pay as little as \$700 for Orinda Control Systems' The Autopilot, or \$4000 for the Wesmar AP1100. And, if you're rolling in money, you can even get a system that uses navigational satellites for bearings.

Regardless of cost, all autopilots contain three major components—the com-

pass, control electronics, and a servo system to control the rudder. The compass is the heart of the system, providing the data needed by the control electronics to determine the correct rudder setting.

They're not all the same

The compasses used in autopilots differ from ordinary marine compasses by having transducers that provide electrical signals proportional to the compass bearing. The control electronics use these signals to steer your boat.

Some manufacturers use photocells and lights to generate the compass signal. Another uses a Hall effect probe. Others use inductive pickups.

Wesmar recently introduced a new device called a *saturable core* compass. This device, which senses the earth's own magnetic field, has no moving parts, so it has an instantaneous response to changes in course. And it's unaffected by rough sea.

The problem with hunting

One problem faced by the autopilot is *hunting*—the constant correcting of small changes in heading caused by oversteering and wave action. Some manufacturers, such as Wesmar, offer



Radar receiver for your boat

Radar is without question one of the best safety devices you can have on your boat. In fog and at night, it lets you know where other boats are in the sea around you. But radar is expensive—\$2000 or more. At those prices you may be inclined to look at radar as a luxury you can live without.

There is a much less expensive way you can benefit from radar, to a limited extent, for about one-quarter the cost. Regent Marine and Instrumentation, 1051 Clinton Street, Buffalo, NY 14206, sells a directional radar alert system, the Drom Model 300, for \$475.

The system uses both lights and an audio alarm to indicate the presence of a radar transmitter nearby. The four lights represent the four quadrants around your boat. When a boat with an operating radar enters the approach zone, about four miles from your boat, the alarm begins to beep. If the boat is well within one of the quad-

rants, the corresponding light begins blinking. If the boat is near the intersection of two quadrants, both lights will blink.

When the boat gets within three miles or so, it enters the detection zone. At this point, the alarm sounds continuously and the lights remain on. If the boat has changed its relative position to your boat, the lights will change to reflect the new bearing.

If the boat strays within a mile or so of your boat, it enters the danger zone. When this happens, the sound level of the alarm increases and all four quadrant lights turn on.

This should give you enough warning to plan your escape maneuvers, get your horn working, and visually locate the other boat.

If you normally operate in waters where most of the boats do not have radar, the Drom 300 will be of little value. It requires the other fellow to have his radar on. But, if most of the boats do have radar, this gadget could save your life.

Selected Loran manufacturers

Aeromarine Electronics, Inc.
6055 Fairmont Ave.
San Diego, CA 92120

Benmar Div. Cetec Corp.
3000 W. Warner Ave.
Santa Ana, CA 92704

Communication Associates, Inc.
200 McKay Rd.
Huntington Station, NY 11746

Digital Marine Electronics Corp.
Civil Air Terminal
Bedford, MA 01730

Epsco Brocks
411 Providence Hwy.
Westwood, MA 02090

Gem Marine Products "Gemtronics"
356 South Blvd.
Lake City, SC 29560

ITT Decca Marine, Inc
Box G
Palm Coast, FL 32037

Konel Corp.
271 Harbor Way
S. San Francisco, CA 94080

Micro Marine, Inc.
2235 Micro Place
Escondido, CA 92025

Mieco, Div. Polarad Electronics Corp.
109 Beaver Ct.
Cockeysville, MD 21030

Morrow Electronics
4740 Ridge Dr., N.E.
Salem, OR 97303

Nautical Electronics Co. Inc. "Nelco"
7095 Milford Industrial Rd.
Baltimore, MD 21208

Ray Jefferson
Main & Cotton Streets
Philadelphia, PA 19127

Raytheon Marine Co.
676 Island Pond Rd.
Manchester, NH 03103

Seatron Div. Jetronic Inc.
4312 Main St.
Philadelphia, PA 19127

Simrad, Inc.
One Labriola Ct.
Armonk, NY 10504

Slep Electronics Co.
PO Box 100
Otto, NC 28763

Smiths Industries Inc., Marine Div.
Box 5389
Clearwater, FL 33518

Sperry Marine Systems Div.
Sperry Rand Corp.
Great Neck, NY 11020

SRD Labs
381 McGlincey Lane
Campbell, Ca 95008

Texas Instruments
Box 6080
Dallas, TX 75222

Vexilar, Inc.
9345 Penn Ave. S.
Minneapolis, MN 55431

Selected autopilot manufacturers

Benmar Div., Cetec Corp.
3000 W. Warner Ave.
Santa Ana, CA 92704

Coe Manufacturing Co.
PO Box 463
Dana Point, CA 92629

Danforth
500 Riverside Industrial Pkwy.
Portland, ME 04103

Energy Control Corp.
1614 130th N.E., Box 127
Bellevue, WA 98009

Epsco Brocks
411 Providence Hwy.
Westwood, MA 02090

First-Mate Marine Autopilots
Box 330778
Miami, FL 33133

International Marine Instrument Inc.
Joshua Solucum Dock
Stamford, CT 06902

Metal Marine Pilot Inc.
2119 W. Mildred St.
Tacoma, WA 98466

Orinda Control Systems
PO Box 203
Orinda, CA 94563

Ray Jefferson
Main & Cotton Streets
Philadelphia, PA 19127

Seatron Div. Jetrionic Ind. Inc.
4312 Main St.
Philadelphia, PA 19127

Signet Scientific Co.
Box 6489, 129 E. Tujunga Ave.
Burbank, CA 91510

Sky-Way Communications
10833 E. Jefferson
Detroit, MI 48214

Sperry Marine Systems
Great Neck, LI, NY

Tiller Master
Box 1901
Newport Beach, CA 92663

Unipas Inc.
1303 Jefferson Blvd.
Warwick, RI 02886

Wesmar Marine Systems Div.
905 Dexter Avenue N.
Box C19074
Seattle, WA 98109

proportional drive options to minimize hunting. Others rely solely on the sensitivity control.

Orinda's The Autopilot avoids hunting with a built-in, adjustable *deadline* control. Depending on your setting, the Autopilot ignores changes in course of less than two to 30 degrees. Over a period of time, small changes due to wind and sea should average out. Once the cumulative effects of these actions exceeds the preset deadband, the Autopilot engages and corrects the heading.



Long distance navigation has always been a problem for some weekend mariners. But this Tamaya Astro-Navigation Calculator, available from the Coastal Navigation School of Santa Barbara, California, should make it much simpler to figure out where you are, what course to steer at what speed for how long to get where you want to go.

Not all marine electronics is as sophisticated as that in radar, sonar, and radio. You'll find electronic circuitry in gauges such as fuel flow meters, apparent wind speed indicators, rudder angle monitors and speedometers.

Add-on electronic gauges come in a wide variety of sizes and shapes. Some are designed for panel mounting; others are packaged in carry-along cases. All are relatively expensive. But the \$100 or so you spend for one of these gauges could save you the cost of a new boat.

How's the engine doing?

Many of the gauges monitor engine operation—temperature, oil pressure and revolutions. In addition to the usual assortment of temperature gauges and tachometers, there are a few, usually overlooked, gauges worth considering.

Two of the most useful of these are the engine compartment air temperature, and engine exhaust temperature gauges. The efficiency of your engine is partly

dependent on the temperature of the intake air used in combustion—especially in diesels. By adjusting engine compartment ventilation to maintain an air intake temperature between 85 and

Emergency Position Indicating Radio Beacons

All EPIRBs transmit simultaneously on 121.5 and 243 MHz with at least 75 mW of power.

■ ACR Electronics, Inc., 3901 N. 29th Ave., Hollywood, FL 33020. The Model RLB-12 uses magnesium battery with three-year replacement cycle, weighs approximately five pounds, is 19½ inches long by 3½ inches in diameter, and costs about \$200.

■ Narco Marine, Commerce Dr., Fort Washington, PA 19034. The MRB-51J uses alkaline batteries with a 1½ year replacement cycle, weighs four pounds, is 9½ inches high, 4½ inches wide, 4 inches deep and costs \$190.

How to get a boat-radio license

If you're running a party boat or otherwise rent your boat to carry six or more passengers, you must have a certified vhf marine radio installation. Even if you never operate your boat for hire, you should carry a marine radio.

Regardless of whether your installation is voluntary or compulsory, it must be licensed. Getting a marine radio station license is very easy. All you have to do is fill out FCC form 502 and mail it to the FCC at PO Box 1050, Gettysburg, PA 17325. There's no fee.

To operate your radio, you'll also need an operator's license. Most pleasure boat operators need only the Restricted Radiotelephone Operator Permit. To get yours, just fill out FCC form 753 and mail to the Gettysburg address given above. There's no fee or exam, and the permit's valid for your lifetime.

Know the rules

Once you've received your licenses and installed your radio you're in business. The rules require you to have a copy of Parts 81 and 83 of Volume IV of the FCC Rules and Regulations. They're available from the Government Printing Office for \$9.50 postpaid.

When you get them, read them thoroughly until you understand them. The FCC is committed to maintaining the highly-structured operation found on the marine bands. If you operate a CB radio on board, remember when you switch radios to switch your operating procedures, too. When you key your marine radio, remember the rules are different.

While the FCC's effort to police the CB band has been less than 100 per cent effective, they are improving their techniques. One very effective tool is the Special Enforcement Force, or SEF, (see March 1978, p. 25).

Big brother is watching

Although the SEF units have been concentrating on CB rules violations, the FCC intends to use them to enforce marine radio regulations as well. And they will have available new direction finding gear that can locate the source of a transmission in just seconds, even if it's in motion.

You can get detailed information about the proper use of marine radio in the new 80-page Marine Radiotelephone Handbook published by the Radio Technical Commission for Marine Services. In addition to complete licensing information, it includes up-to-date lists of all marine operators, FCC offices, Coast Guard radio-monitoring stations and weather stations. You'll also find sections dealing with emergency position indicators and CB radios. It's \$3.00 postpaid from RTCM, PO Box 19087, Washington, DC 20036.

FCC Form 502 September 1975		United States of America FEDERAL COMMUNICATIONS COMMISSION		Form Approved GAO No. B-180227 (R0204)	
APPLICATION FOR SHIP RADIOTELEPHONE AND/OR RADIONAVIGATION STATION LICENSE					
FOR COMMISSION USE (Fee Stamp)			FOR COMMISSION USE (Interim License Information)		
			<input type="checkbox"/> RADIOTELEPHONY <input type="checkbox"/> RADIONAVIGATION <input type="checkbox"/> EPIRB		
ISSUING OFFICER			CALL SIGN		
ISSUED BY			DATE ISSUED		
READ INSTRUCTIONS BEFORE FILLING OUT FORM. USE TYPEWRITER OR PRINT CLEARLY IN INK					
1A. NAME OF INDIVIDUAL (Last, First, Middle Initial)			1B. NAME IF OTHER THAN INDIVIDUAL		
2. MAILING ADDRESS OF APPLICANT (Number and Street, City, State and Zip Code)					
3. TYPE OF APPLICANT (Check one)			4A. TYPE OF LICENSE (Check one)		
<input type="checkbox"/> (I) Individual <input type="checkbox"/> (C) Corporation <input type="checkbox"/> (P) Partnership <input type="checkbox"/> (D) Individual with business name <input type="checkbox"/> (A) Association <input type="checkbox"/> (G) Governmental entity			<input type="checkbox"/> Regular <input type="checkbox"/> Plurality <input type="checkbox"/> Portable (Attach required showings)		
4B. IF YOU CHECKED PLURALITY, ENTER NUMBER OF SHIPS TO BE COVERED					
5. NAME OF SHIP		6. IS SHIP NUMBERED OR OTHERWISE REGISTERED IN THE UNITED STATES? IF NO, EXPLAIN WHY NOT.			
		YES NO			
7. OFFICIAL NUMBER OF SHIP (Coast Guard Documentation No., or Federal or State Registration No.)		B. CALL SIGN (Previously assigned to ship, if any)		9. CLASS OF SHIP (See instruction)	
				A. GENERAL B. SPECIFIC	
ITEMS 10-14. CHECK ALL FREQUENCIES TO BE USED BY APPLICANT					
10. RADIOTELEPHONY FREQUENCIES			11. RADIONAVIGATION (Radio) FREQUENCIES		
<input type="checkbox"/> 156-158 MHz <input type="checkbox"/> 1600-4000 kHz <input type="checkbox"/> 4000-23000 kHz <input type="checkbox"/> OTHER (Specify and explain)			<input type="checkbox"/> 2900-3100 MHz <input type="checkbox"/> OTHER (Specify and explain) <input type="checkbox"/> 9300-9500 MHz		
ITEMS 12-14. EMERGENCY POSITION INDICATING RADIO BEACON (EPIRB) INFORMATION					
12A. FREQUENCY	12B. QUANTITY	13A. FREQUENCY	13B. QUANTITY	14A. FREQUENCY	14B. QUANTITY
<input type="checkbox"/> 121.5 MHz		<input type="checkbox"/> 243 MHz		<input type="checkbox"/> 2182 kHz	
15. If 121.5 or 243 mhz are requested for EPIRB'S, is the ship expected to operate in international waters beyond the range of marine VHF distress coverage, or is the EPIRB required by the U.S. Coast Guard.					
YES NO					
16A. Will applicant own the radio equipment? If no, give name of owner in item 16B.					
YES NO					
16B. Name of owner of the equipment					
17. If not the owner of the radio equipment, is applicant party to a lease or other agreement under which he maintains full control of it.					
YES NO					
18. Will each transmitter be a type accepted or approved by the Commission in accordance with part 83 of the Rules? If no, explain on reverse.					
YES NO					
19. Will the ship normally communicate with foreign coast stations or make international voyages?					
YES NO					
20. Will this ship be used at any time to transport passengers for hire? If yes, give the maximum number to be carried per voyage.					
NUMBER					
READ CAREFULLY BEFORE SIGNING					
Certifications: 1) The applicant waives any claim to the use of any particular frequency or of the ether because of previous use of same, whether by license or otherwise. 2) The applicant accepts full responsibility for the operation and control of the requested station license in accordance with applicable law and rules of the FCC. 3) The applicant will have unlimited access to the radio equipment and will take effective measures to prevent its use by unauthorized persons. 4) Neither applicant nor any member thereof is a foreign government or representative thereof.					
WILLFUL FALSE STATEMENTS MADE ON THIS FORM OR ATTACHMENTS ARE PUNISHABLE BY FINE AND IMPRISONMENT. U.S. CODE, TITLE 18, SECTION 1001.		21. SIGNATURE of individual, partner, or authorized person on behalf of a governmental entity, or an officer of a corporation or association.		DATE	

Every marine radio, including EPIRBs, must be licensed by the FCC. To get your radio licensed, all you have to do is fill out form 502 and mail it to P.O. Box 1040, Gettysburg, PA 17325.

FCC FORM 753 SEPTEMBER 1976 PART 2		FEDERAL COMMUNICATIONS COMMISSION P.O. BOX 1090 GETTYSBURG, PA 17325		APPROVED BY GAO # 180227 (R0225)	
APPLICATION FOR RESTRICTED RADIOTELEPHONE OPERATOR PERMIT BY DECLARATION					
A. USE TYPEWRITER OR PRINT IN INK. Signatures must be handwritten. Be sure to complete all items including 7, 8, 9, and 10. B. Enclose fee with application. See Fee Schedule, (FCC Form 76-K). DO NOT SEND CASH. Make check or money order payable to FEDERAL COMMUNICATIONS COMMISSION. C. No oral or written examination is required. Applicant must be at least 14 years of age. D. Submit application: Parts I and II to FCC, P.O. Box 1050, Gettysburg, Pa. 17325. E. ALIENS should submit FCC Form 755 instead of this form.					
DO NOT WRITE IN THIS BLOCK					
① REASON FOR APPLICATION <input type="checkbox"/> NEW PERMIT <input type="checkbox"/> NAME CHANGE (Attach Present Permit) <input type="checkbox"/> REPLACE PRESENT PERMIT DUE TO ITS CONDITION (Attach Present Permit)			<input type="checkbox"/> ORIGINAL PERMIT IS LOST OR DESTROYED. IF FOUND I WILL RETURN IT TO FCC. A REASONABLE SEARCH HAS BEEN MADE FOR THE PERMIT. <input type="checkbox"/> OTHER (Specify)		
② NAME (Last)		FIRST		Middle Initial	
PERMANENT ADDRESS (No. & Street)					
CITY		STATE		ZIP CODE	

You'll need a valid Restricted Operator's Permit to operate your marine radio. There's no fee and no exam for this lifetime permit. Just fill out the computer-card form 753 application and mail it to P.O. Box 1040, Gettysburg, PA 17325.



Gemtronics' GT-207C Accu-Fix Loran C receiver is just the thing for offshore sailors. Weighing a little over 12 pounds in a cabinet approximately six inches high by 10 inches wide and 12 inches deep, the GT-207C has a daytime range of about 1500 miles, and 2300 miles at night.

90 degrees, you'll be able to squeeze the last mile out of a gallon of fuel.

You can keep track of your engines condition by monitoring its exhaust temperature. As the engine works harder, the exhaust temperature rises. If you notice the temperature increasing over a period of time for the same kind of operation, it may be time to give your engine a going over.

Another gauge that can provide an indication of engine performance is the fuel flow meter. If you notice a significant increase in fuel consumption while cruising at a steady speed, for example, your engine is probably in need of help.

Vapor detectors save lives

If you have an inboard engine, you must have a vapor detector in the engine compartment. Its purpose is to warn you of a dangerous build-up of explosive gas fumes.

When the alarm signals the presence of fumes, shut down the engine and electrical system, and ventilate the compartment. If you don't, you're risking an explosion that could cost you your boat, and even your life.

Several manufacturers make vapor detectors. Aqua Meter's \$160 Sentry is typical of the more sophisticated detectors. A green light lets you know the detector is on and no gas fumes are present. When fumes are detected, an amber light goes on along with a high-pitched audio alarm. If you don't take action quickly, and the concentration of fumes reaches the explosive level, a red light goes on and the volume of the alarm increases.

Where's the wind?

If you're a sailor, gauges to monitor engine performance won't interest you. But, wind direction and speed indicators should. And powerboat operators will find them useful for laying in course corrections when they find themselves in the middle of a good sized squall.

You can get separate wind speed and wind direction gauges, or a combined instrument that gives both measurements. But, regardless of which type you get, the wind speed indicated is the



Regency's Aquafone is typical of the smaller vhf-fm marine radios. Packed into a cabinet no larger than most mobile CB radios, the Aquafone has six two-way channels and two receive-only weather channels for monitoring the NOAA weather broadcasts.

Help at pinpointing your location

Brand	Number of Bands	Null meter included	Price
Selected radio direction finders			
Aqua Meter Instrument Corp., 465 Eagle Rock Ave., Roseland, NJ 07068 CH-705	5	yes	\$260
Davis Instruments Corp., 642-143rd Ave., San Leandro, CA 94578 HELP/174	2	no	70
Epsco Brocks "Seafarer", 411 Providence Hwy., Westwood, MA 02090 Seaspot 2	2	no	239
Heath Co. "Heathkit", Benton Harbor, MI 49022 MR-1010	2	yes	200
Pearce-Simpson, Div. Gladding Corp., 4701 NW 77th Ave., Miami FL 33166 Gulfstream Islander	5 6	yes yes	210 150
Plastimo "Shark", 809 Aquidneck Ave., Middletown, RI 02840 65-13-05-1	4	yes	567
Ray Jefferson, Main & Cotton Sts., Philadelphia, PA 19127 RDF 630 640	6 5 5	yes yes yes	130 180 220
Raytheon Marine Co., 676 Island Pond Road, Manchester, NH 03103 Ray DF-20	3	yes	330
Unimetrics, Inc., 123 Jericho Pke., Syosset, NY 11791 Unimetrics	5	yes	249
V/T Sales Corp. "Vecta", 1331 S Dixie Hwy. W., Pompano Beach FL 33060 Vecta	2	yes	200
Selected automatic direction finders			
Gem Marine Products "Gemtronics", 356 South Blvd., Lake City, SC 29560 GT-302	3	yes	549
Ray Jefferson, Main & Cotton Streets, Philadelphia, PA 19127 6150	4	yes	430
Konel Corp., 271 Harbor Way S., San Francisco, CA 94080 ADF-5 FDK-1	3 5	yes yes	1595 4275
Pearce-Simpson, Div. Gladding Corp., 4701 N.W. 77th Ave., Miami, FL 33166 Newport	5	yes	430
Raytheon Marine Co., 676 Island Pond Road, Manchester, NH 03103 Navimatic	3	yes	1460
Smiths Industries Inc., Marine Div., Box 5389, Clearwater, FL 33518 Si-TeX/Koden	3	yes	1395

A VHF fm marine radio is better than CB for your boat

Many boat owners are turning away from the relatively expensive marine radios, and instead are using CB. Although the Coast Guard informally monitors CB for distress calls, they maintain their primary watch on vhf channel 16. So, if for no other reason than this, you should carry a vhf marine radio on your boat.

However, there is another good reason for carrying marine radio—Ma Bell. Using your marine radio, you can make telephone calls to just about any part of the world. Ma Bell, and many independent companies as well, maintain a network of land stations licensed for ship-to-shore public correspondence.

Placing a call from your boat is very easy. All you do is switch your vhf radio to channel 26 or channel 28, depending on your location. If the channel is clear, key your transmitter for about five seconds.

Number please

When the marine operator answers, give your callsign and the name of your vessel, answer any questions the operator has, and make your call. When you're through, just sign off. That's all there is to it.

You also can receive telephone calls on board your vessel. Of course, your radio will have to be left on, and tuned to the ship-to-shore calling frequency.

Since compulsory equipped boats must monitor channel 16, the Bell System marine operators, and most independents as well, use it to establish contact. Once you've been contacted, you'll be asked to shift to a working channel to receive your call.

Coastal waters are different

Although the FCC requires every licensed radio installation to carry vhf marine band radios, many boats also carry medium wave single sideband equipment. If you have an SSB radio and want to receive ship-to-shore telephone calls, you must tell your callers in advance what frequency you'll be monitoring.

The range over which you can send and receive telephone calls through a marine operator depends on your equipment, antenna height, and the land station's location. Under good conditions, you can make vhf calls of up to 50 miles. Using SSB, 300 miles or more is possible.



The Gemtronics GT-1202S is claimed to be one the most sophisticated flasher-recorders available. With an overall depth range of 480 feet, its special 30-foot range makes it ideal for bass and other shallow water fishing.

apparent wind speed—how fast the wind is passing over your boat. How close the apparent speed is to the true wind speed depends on how fast and in what direction your boat is traveling.

You can measure your boat's speed through the water with any of the many speedometers available. But, here too the indication is one of apparent speed, not true speed. If, for example, your speedometer shows an apparent speed of 10 knots while your moving against an eight-knot tide, your true speed is only two knots.

The old megaphone used for centuries to hail other boats is now the electronic hailer. The hailer is much more than just a specialized PA system too. Not only can you use it to amplify your voice, you can also use it to amplify the voice of the other boatsman hailing you.

Most of the hailers have built-in electronic fog horns. Some, such as Inmar's Seaspeak, can be sounded manually, or set for automatic operation. And most hailers can also be used as an on board intercom as well.

The other kind of flasher

Although you probably don't think of lighting in terms of electronic circuitry, some lights do use electronics. These are the high intensity anti-collision and rescue strobe lights.

Most of these lights use a xenon flash tube and self-contained oscillator circuit. Anti-collision lights are usually powered

by the boat's electrical system. Rescue lights run off disposable batteries.

The usable range of these lights depends on the weather and location of the observer. ACR's Firefly, for example, is a rescue light about the size of a pack of cigarettes. But its single mercury battery is enough to produce about 50 flashes per minute for over nine hours of operation. The flash, which has a brilliance of 250,000 peak lumens which can be seen up to 5 miles distant on a clear night.

Here I am

If you suffer an on-board explosion or hit something, and your boat sinks, you can expect to be in the water for a long time. How long depends on how long it takes someone to realize you're missing and then find you.

You can shorten your wait with an emergency position indicating radio beacon (EPIRB). These small, self-contained radio transmitters operate for days while in the water. They transmit on international distress frequencies that are always monitored. If you do a lot of deep sea fishing that puts you out of range of your vhf radio, an EPIRB is a must.

Marine electronics, just like every other area of hobby electronics, has something to offer everyone. Although you can spend almost as much for the electronics as you did for your boat, they add not only pleasure, but life-saving safety.

YOU... AND AMSAT PHASE III

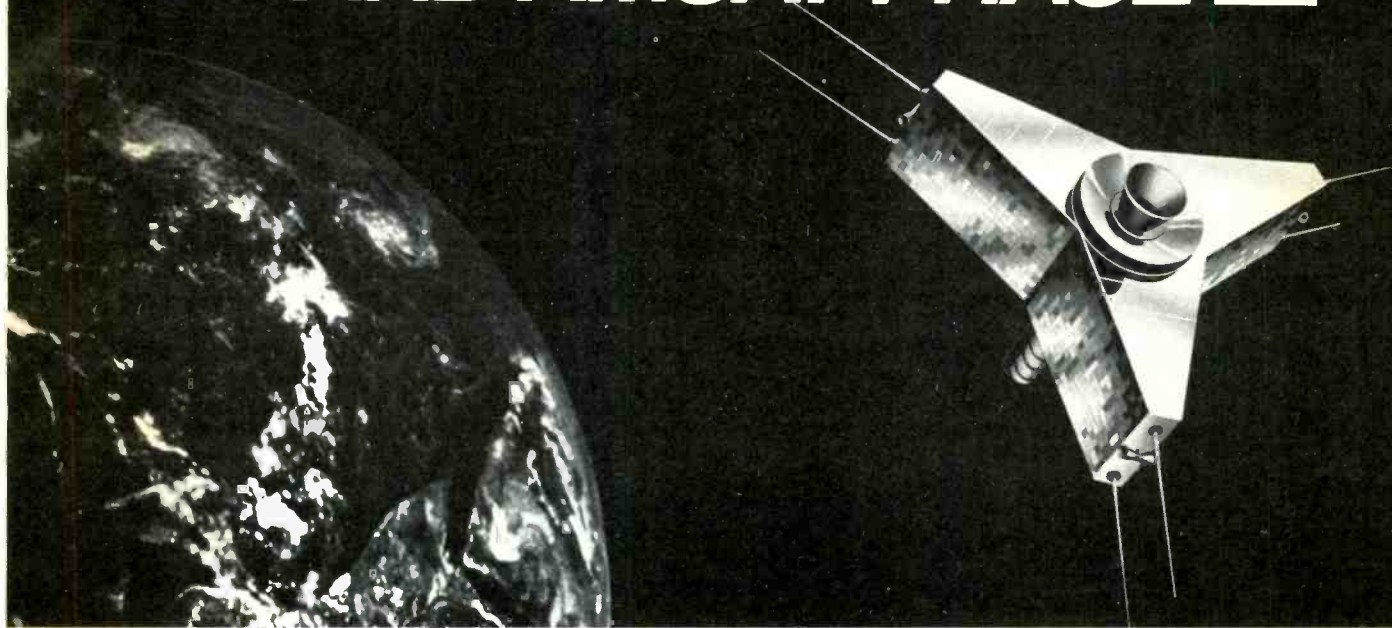

An exciting new era in amateur radio is about to begin... the era of AMSAT PHASE III OSCAR satellites.

Many of you are familiar with the benefits of the AMSAT OSCAR satellites, notably OSCAR 6 and 7. These satellites, with a combined total of over 8 years in orbit, have provided communications between amateurs throughout the world. They have also provided a capability for an educational program in space sciences and many interesting experiments.

AMSAT, with members and contributing groups worldwide, and headquarters in Washington, D. C., has been responsible for our current satellite program. Many people feel that perhaps the greatest value of the amateur satellite program is the dramatic demonstration of amateur resourcefulness and technical capability to radio spectrum policy makers around the world.

The value of this aspect of amateur radio as we prepare for the 1979 World Administrative Radio Conference (WARC) is enormous.

The AMSAT PHASE III satellite program promises a continuing demonstration that amateur radio is at the forefront of modern technology. PHASE III satellites will routinely provide reliable communications over paths of up to 11,000 miles (17,600 km) for 17 hours each day. You can think of them as a resource equivalent to a new band.

The cost of these PHASE III satellites is a projected \$250,000. Commercial satellites of similar performance would cost nearly \$10,000,000.

Your help is needed to put these PHASE III OSCAR satellites in orbit.

Your valued, tax-deductible contribution can be as small as one of the 5000+ solar cells needed. A handsome certificate will acknowledge the numbered cells you sponsor for \$10 each. Larger components of the satellites may also be sponsored with contribution acknowledgements ranging to a plaque carrying your name aboard the satellites. Call or write us for the opportunities available.

Your membership in AMSAT is important to the satellite program, and will give AMSAT a stronger voice in regulatory matters concerned with satellites. At \$10 per year or \$100 for life, you will be making a most significant contribution to the satellite program and the future of amateur radio. You will also receive the quarterly AMSAT newsletter.

Clip the AMSAT PHASE III coupon below and send your support today, or call 202-488-8649 and charge your contribution to your BankAmericard (VISA) or Master Charge card.



AMSAT PHASE III
Radio Amateur Satellite Corporation
Box 27 ME Washington, D. C. 20044
202-488-8649

YES, I want to support AMSAT PHASE III OSCAR satellites. Enclosed is:

- \$_____ in sponsorship of _____ solar cells (@ \$10 each)
 \$10 Annual membership \$100 Life membership
 Send information on sponsoring larger satellite components.

Name _____ Call _____ AMSAT Member? _____

Street _____

City _____ State _____ Zip _____

The publisher has donated this space to AMSAT in support of AMSAT and the PHASE III program.

program

TRY THIS ON YOUR HOME COMPUTER

BY PETE STARK

It's not 3.14. Nor is it 3.141592653589793238462643. And it's not even 22/7. Will the real Pi please stand up?

As every high school student knows, the number π is a number which we use to calculate the area or circumference of a circle.

We usually approximate it as 3.14, but in reality it happens to be an infinitely long number which starts with the digits 3.141592653589793238462643. Since it is infinitely long, there is no way of knowing exactly what π is, but there have been some computer programs written to find the first 10,000 or so digits of π .

Finding a few thousand digits of π may be fun, but it is certainly not a practical thing to do. For most uses it is good enough to approximate π with a shorter number such as 3.14 or perhaps 3.14159. In fact, a popular alternative often taught in high school is the fraction $22/7$, which is equal to about 3.1429—close to the real value of π . Using $22/7$ instead of π introduces an error of about 0.04 percent into a calculation, and that is certainly good enough for most common problems.

But there are other fractions which are either easier to remember than $22/7$ or a lot more accurate. This program written in BASIC finds these other fractions which could be used as approximations for π . As you can see from the printout of the program's results, $22/7$ happens to be the best of the simple fractions.

If we are willing to accept slightly longer fractions, we find that $179/57$ is slightly closer to the real value of π but certainly harder to remember. On the other hand, the fraction $355/113$ is a really good approximation. Its value of 3.14159292 is only 0.000008 percent from the true value. It is even fairly easy to remember, since if you read the denominator (bottom number) followed by the numerator (top number), you get 113355.

How does the computer check different fractions and look for good ones? It works by simply trying different frac-

LIST

```
0100 REM THIS PROGRAM FINDS APPROXIMATIONS
0110 REM TO PI = 3.14159265
0120 P = 3.14159265
0130 E=1
0140 FOR D = 1 TO 500
0150 N1 = INT(P*D)
0160 N2 = N1 + 1
0170 F = N1/D
0180 E1 = ABS(F-P)
0190 IF E1>=E GO TO 230
0200 E = E1
0210 PRINT N1; "/ "; D; " IS "; F
0220 GOTO 280
0230 F = N2/D
0240 E2 = ABS(F-P)
0250 IF E2>=E GO TO 280
0260 E = E2
0270 PRINT N2; "/ "; D; " IS "; F
0280 NEXT D
```

READY

#RUN

```
3 / 1 IS 3
13 / 4 IS 3.25
16 / 5 IS 3.2
19 / 6 IS 3.16666666
22 / 7 IS 3.14285714
179 / 57 IS 3.14035087
201 / 64 IS 3.140625
223 / 71 IS 3.14084507
245 / 78 IS 3.14102564
267 / 85 IS 3.14117647
289 / 92 IS 3.14130434
311 / 99 IS 3.14141414
333 / 106 IS 3.14150943
355 / 113 IS 3.14159292
```

READY

#

tions until it finds a good one, and then prints out the one it found. Many hundreds of calculations are needed to find a good set of fractions, but the computer can do them so fast that there is nothing wrong with using this method.

Although short, our program does a lot. In line 120 we define the number P to be equal to a fairly accurate value for pi. Line 130 then defines E as being equal to 1. The symbol P stands for pi, and E stands for the error.

Lines 140 through 280 define a loop—a part of the program which is repeated over and over. In this case, the statement 140 FOR D=1 TO 500 tells the computer to repeat that loop 500 times. For each repetition, D takes on a new value, starting with 1, then 2, and so on, all the way to 500. Thus D acts as a counter to count off repetitions of the loop, but it also stands for denominator. Each repetition of the loop tries a different denominator.

For each different denominator D, lines 150 and 160 calculate two different numerators which should be tried. Line 150 multiplies the denominator D by the true value of pi, and then keeps only the integer portion of the answer, calling it N1. The second numerator N2 is simply the next higher integer, equal to N1 plus 1.

For example, the first repetition of the loop, D is equal to 1. D times pi is 3.14..., and the integer portion of this is 3. Thus N1 becomes 3 and N2 becomes 4. The reason is that the next few lines are going to try two fractions: N1/D (which is 3/1 or 3) and N2/D (which is 4/1 or 4).

The first fraction is a bit smaller than pi, while the second fraction is a bit larger than pi. In any case, for that particular denominator D those are the only two numerators that are worth trying for an approximation to pi.

We could, of course, have the computer try all possible combinations of numerator and denominator, but that would take a very, very long time even for a fast computer. This process helps to limit the number of combinations which have to be tried.

Once we choose N1 and N2, line 170 calculates the first fraction $F = N1/D$. Line 180 calculates the error this gives by subtracting pi from this fraction and taking the absolute value of the answer—that is, making the result always positive. This new error is called E1.

Next, in line 190, comes the test with an IF. Is this new error E1 larger than the previous error E? If so, GO TO 230 and forget about this fraction, since we've already found a better one.

On the other hand, if this new error is smaller than E, then obviously we have found a good fraction whose error is smaller than the best fraction found previously. In that case we store the value of E1 as E, and print the values of N1, D, and the fraction F. Then we go to the end of the loop at line 280.

The remainder of the loop, lines 230 through 270, is a repetition of the first half, except that this time we try N2 as the numerator instead of N1.

The secret of the entire program is in its use of E. At the very beginning, we force E to be 1. The very first fraction we try is 3/1. Line 180 finds that the error between 3 and the true value of pi at 3.14

is about 0.14, and so E1 is 0.14. Since this is smaller than the value of E, which is 1, the computer goes through line 190 to line 200, making E equal to 0.14, and then printing 3 / 1 IS 3 in line 210.

The very next fraction tried is 4/1 but this time the error is about 0.86 (since the difference between 4 and the real value of pi is 4 - 3.14, or about 0.86). Since E2 is now larger than E, line 250 tells the computer to GO TO 280 and try the next value of the denominator D. And so the computer keeps trying the fractions in this order:

3/1
4/1
6/2
7/2
9/3
10/3
12/4
13/4

Not until 13/4 does it find a fraction which is better than 3/1, and so the next line of the printout is 13/4 IS 3.25 as shown.

The program loop is run for denominators from 1 to 500, but the printout shows the largest denominator as 113. The reason is that none of the fractions with larger denominators give as good results as 355/113. In fact, to get a better answer we must go up to numbers in the thousands.

For instance, 102928 divided by 32763 gives almost exactly 3.14159265, but this is not practical. After all, the reason for looking for fractions is to have a simple way of calculating pi if we don't remember the value itself, and these two numbers are harder to remember than even pi itself.

Games and statistical research and even other computer programs require random numbers from time to time. Here's a super-simple program, in Basic language for your home computer, to generate random numbers.

BY CARMINE PRESTIA

Here is an example of a small, easy and quickly developed program. It took less than one half hour to work up this program on our Heathkit H8 computer and H9 video display terminal. The program is written in Heath's Extended Benton Harbor Basic.

The idea for this program came from a discussion with a friend. One of his pastimes is playing a complex tactical war game called "The Empire of the Petal Throne", developed by M.A.R. Barker. This is a fantasy adventure set on an alien planet called Tekumel. The characteristics of the players and the moves

Program Listing

```
10 REM RANDOM, VER 1, 10/24/77 - RANDOM NUMBER GENERATOR
15 REM TO GENERATE A SERIES OF 40 NUMBERS BETWEEN 0 & 100
20 REM USE "SHORT FORM" VIDEO OUTPUT
25 FOR A=0 TO 40
30 PRINT INT(RND(1)*100)
35 NEXT
40 END
```

that they make are determined by random numbers that the participants obtain by casting percentile dice. In one case, random numbers are needed in the range of 1 to 100.

Since random numbers and games are right at home with computers I offered the services of my H8 system to supply these numbers.

This program uses the random number generator function (RND) that is included in the Heath Basic language.

Since this function delivers a random number less than one, the number is multiplied times 100 to obtain a number between zero and 99.

The integer function (INT) is used to discard the decimal part of the number that remains. A loop is established in lines 25 and 35 that tells the computer to find and print a random number 40 times. The "short form" video output is used so that all the numbers will be printed on the screen. This is a function

that Heath has built into the H9 video display for just such instances. When you want a list of short items, like numbers, just press the "short form" button on the H9 and you get 48 lines of 20 characters each instead of the usual 12 lines of 80 characters each.

Give it a try yourself, or even go a few steps further and design your own games programs. How about one to play "craps" with the computer? That way you don't lose any cash.

This program shows you how to make tests for your kids, wife, girl friend or mother-in-law.

BY THOMAS ROHR

This program written in Basic computer language shows how to program a computer to give examinations to students.

The program asks three simple questions about electronic theory. After each question it waits for an answer to be typed in. After each answer, it tells the student whether his answer is correct or not. If it is incorrect, it then types out the correct answer. After all three questions, the computer prints out the number of answers which were right and the overall grade for the test.

The program is a very simple one and demonstrates what Basic can do. It starts in line 100 with several PRINT statements, which start off the test by printing the rules and the first question.

The PRINT statement can be used to print out values of numbers, but in this case it is used to print out a message which is enclosed in parentheses in the program. Following this, line 150 sets a number C equal to zero. C will be used to keep track of how many questions were answered correctly, and it is, therefore, forced to zero at the beginning.

The INPUT statement in line 160 causes the computer to type a question mark and wait for an answer. Once an answer is received, the IF statement in line 170 checks to see whether it is right or wrong.

The correct answer to the first question is 1. If the answer received was 1, then the statement IF A=1 sends the program to line 200 which adds one to C. The following line would then print out YOU GOT THAT ONE RIGHT.

On the other hand, if the answer was not a 1, then the program continues right through the IF at line 170, and prints SORRY. . . . , as shown in line 180.

Sample program

```

100 PRINT "HELLO, WOULD YOU LIKE TO TAKE A BASIC ELECTRONIC QUIZ?"
110 PRINT "I WILL ASK YOU A QUESTION AND YOU TYPE IN 1, 2, OR 3"
120 PRINT "AS AN ANSWER, FIRST QUESTION:"
130 PRINT "POWER IS MEASURED IN WHAT UNITS - 1) WATTS,"
140 PRINT "2) VOLTS, OR 3) AMPERES?"
150 C=0
160 INPUT A
170 IF A=1 GO TO 200
180 PRINT "SORRY, BUT THE CORRECT ANSWER IS 1) WATTS."
190 GO TO 220
200 C=C+1
210 PRINT "YOU GOT THAT ONE RIGHT."
220 PRINT "IF THE CURRENT THROUGH A 5 OHM RESISTOR IS"
230 PRINT "4 AMPERES, THE VOLTAGE ACROSS IT IS"
240 PRINT "EQUAL TO 1)45, 2)20, 3)50 VOLTS."
250 INPUT A
260 IF A=2 GO TO 300
270 PRINT "TOO BAD, BUT YOU MISSED IT, VOLTAGE IS CURRENT"
280 PRINT "TIMES RESISTANCE, OR 20 VOLTS."
290 GO TO 320
300 C=C+1
310 PRINT "YOUR ANSWER IS CORRECT."
320 PRINT "IN A SERIES CIRCUIT WHICH IS DIVIDED? 1)VOLTAGE, 2)CURRENT."
330 INPUT A
340 IF A=1 GO TO 370
350 PRINT "YOUR CHOICE IS WRONG. THE CORRECT ANSWER IS 1)VOLTAGE."
360 GO TO 390
370 C=C+1
380 PRINT "YOU GOT THAT ONE RIGHT BUT YOU HAD A 50-50 CHANCE."
390 G=C/3*100
400 PRINT "YOUR NUMBER OF CORRECT ANSWERS IS"; C; "OUT OF 3."
410 PRINT "YOUR GRADE IS"; G; "PERCENT."
420 PRINT "WELL, I HAVE TO GO NOW. I'LL SEE YOU THE NEXT TIME"
430 PRINT "YOU WANT TO TRY THIS QUIZ. GOODBYE."
440 STOP

```

All three questions are programmed in the same way. If the answer is correct, then the computer prints out a message of encouragement. If the answer is wrong, then it corrects the student.

After it has responded to the last answer, the computer prints out the

value of C, which is the number of correct answers, in line 400, sandwiched between the words YOUR NUMBER OF CORRECT ANSWERS IS and OUT OF 3. Line 410 then prints out the grade, which was calculated in line 390 using the formula C/3 times 100. Finally, lines 420 and 430 print a goodbye message. 

ok[®] wire wrapping center ok[®]

NEW HOBBY WRAP MODEL BW 630



Battery wire wrapping tool

\$34.95

ONLY \$34.95 COMPLETE WITH BIT AND SLEEVE

STRIP / WRAP / UNWRAP MODEL WSU-30



\$6.95*

RIBBON CABLE ASSEMBLY

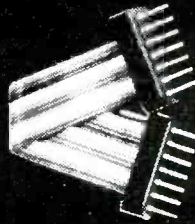

DIP SOCKETS

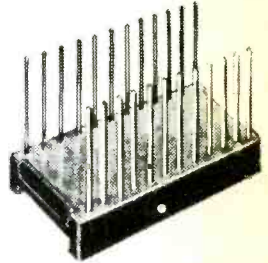

DIP IC INSERTION TOOL WITH PIN STRAIGHTENER

MODEL INS-1416



\$3.49*

WIRE DISPENSER MODEL WD-30-B



\$3.95*

PRE-CUT PRE-STRIPPED WIRE

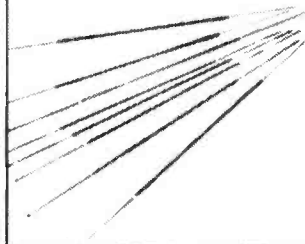

WIRE WRAPPING KIT

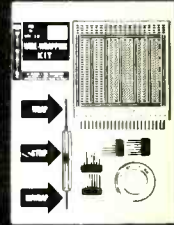

\$15.45*

*MINIMUM ORDER \$25.00. SHIPPING CHARGE \$1.00. N.Y. CITY AND STATE RESIDENTS ADD TAX

OK MACHINE AND TOOL CORPORATION

3455 CONNER STREET, BRONX, NEW YORK, N.Y. 10475 U.S.A.

PHONE (212) 994-6600 TELEX NO. 125091

CIRCLE 66 ON READER SERVICE CARD

WANTED

OLD LIONEL TRAINS

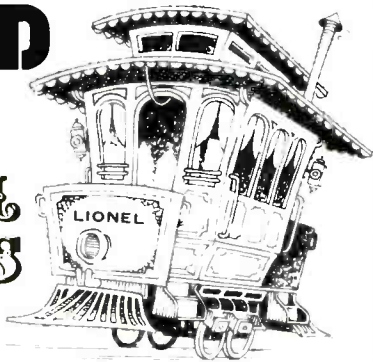

Especially pre-WW II "O" Gauge and Standard Gauge. Certain engine models are particularly needed. These are 5344, 700E, 763, 773 and 736. Also want 256, 260E, 255, 263, 752. Passenger cars bring good prices in excellent or better condition.

These trains will be for my personal collection. For that reason I can offer top cash or great swaps in radio equipment. Certain accessories bring mucho money. For example, the Lionel Industrial Power Station, Hell Gate Bridge, Scenic Park, etc.

I don't collect American Flyer or Lionel "O 27" gauge, but I will pay extra premiums for Ives models. Don't be bashful. Those old clunkers in your basement or attic will look great on my den walls.

Please write: **DICK COWAN, Publisher ME**
14 Vanderventer Ave., Port Washington, N.Y. 11050
 Better still, call collect, if you're not certain what you have.
516/883-6200

8700 Computer/Controller

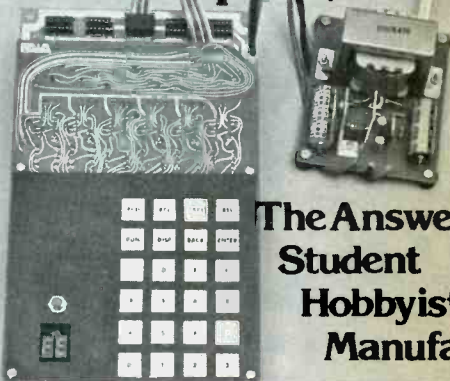

The Answer For...
Student
Hobbyist
Manufacturer

8700 Processor: 6503 MPU. Wear free "Active Keyboard". Micro-Diagnostic.[®] Extensive documentation. Fully Socketed.

Piebug Monitor: Relative address calculator. Pointer High-low. User Subroutines. Back-step key.

Cassette Interface: Load & Dump by file #. Tape motion control. Positive indication of operation.

Applications systems from \$90 (10 unit quantity)

Development systems from \$149 (single unit)

TELL ME MORE

I want to see for myself that the 8700 is The Answer.

Please send documentation and price lists. \$10 enclosed. name: _____

I don't need documentation please send price lists. address: _____

Please send FREE CATALOG. city: _____ state: _____ zip: _____



EIA ELECTRONICS Dept. 5-E • 1020 W. Wilshire Blvd. • Oklahoma City, OK 73116 (405) 843-9626

CIRCLE 95 ON READER SERVICE CARD

**If they copy the style,
they can't match the quality.**

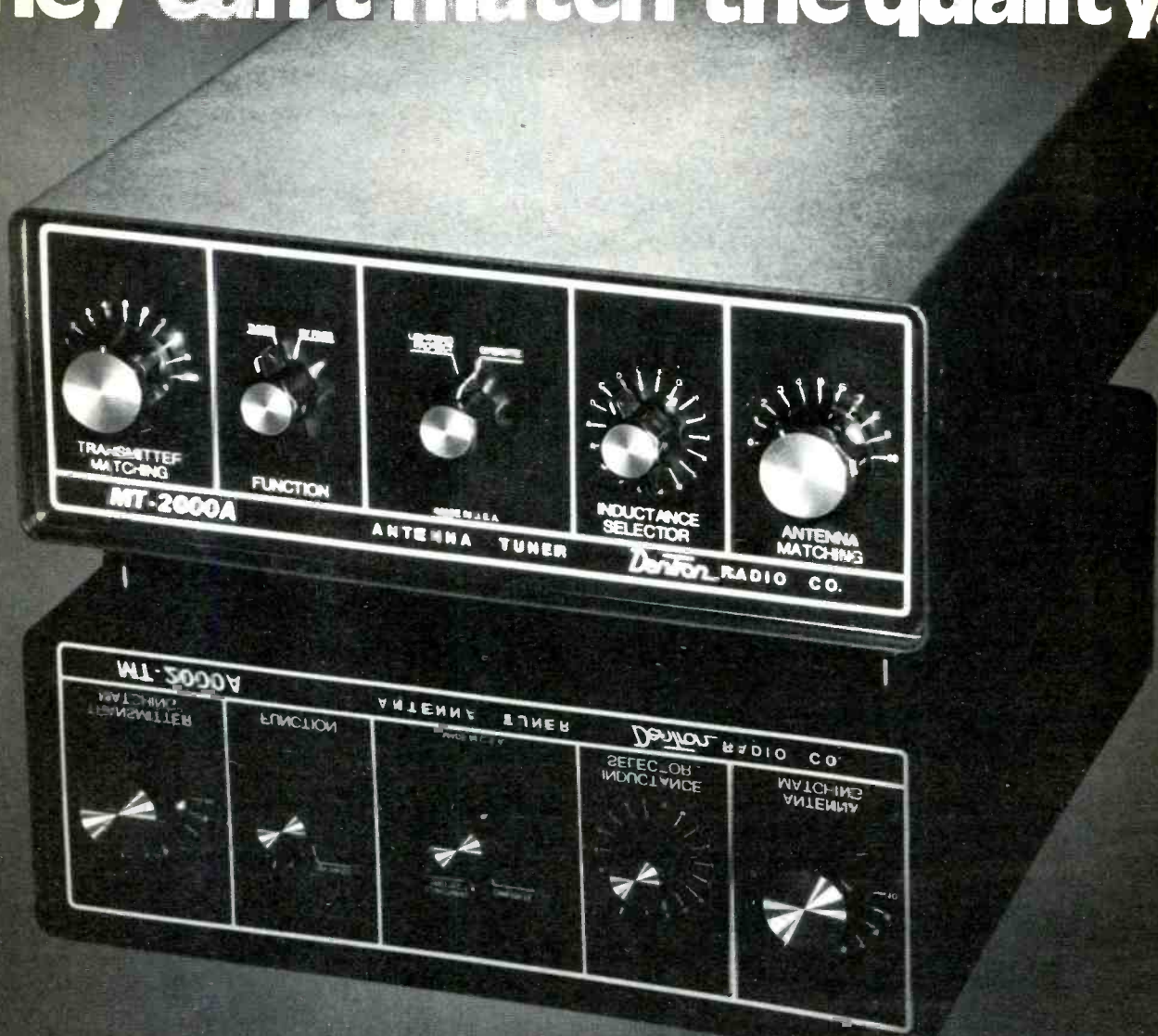

**If they copy the quality,
they can't meet the price.**

The original DenTron Super Tuner. The original Super Super Tuner. The original MT-3000A. And now DenTron brings you the original MT-2000A, an economical, full-power tuner designed to handle virtually any type of antenna.

The sleek styling and low profile of the MT-2000A is beautiful, but be assured that is only a part of the excitement you'll derive from the MT-2000A. The MT-2000A is designed and engineered using heavy-duty all-metal cabinetry, and high quality American components throughout.

When you consider the MT-2000A's unique features 5 1/2" H x 14" D x 14" W, front panel coax bypass switching, front panel lightning protection antenna grounding switch, 3K V PEP, and the ability to match

coax, random wire and balanced feedline, we're sure you'll decide to buy an American original and stay with DenTron.

MT-2000A \$199.50 at your favorite dealer.

DenTron

Radio Co., Inc.
2100 Enterprise Parkway
Twinsburg, Ohio 44087

216 425-3173



AMERICA'S
FAVORITE

Wilson

8-Element Shooting Star

Directional, Dual Polarity, Yagi-Quad
CB Base Station Antenna with DPE*

When size or economics are your main consideration, consider the 8-element Shooting Star with DPE*. Developed to fill the need for top performance, dual polarity operation at an economical price, the Shooting Star has a gain of 14 dB. That's like broadcasting with 28 times your normal power!

The design uses a 16-foot boom with six scientifically-spaced 18 foot elements and a quad reflector to obtain the best combination of gain and front-to-back ratio. It's the same design used to bounce signals off the moon!

Using the same construction as the famous Wilson Laser beams, with heavy-wall aircraft-type aluminum tubing and Wilson's special extruded element clamps, the Shooting Star's mechanical construction is superior to other like antennas. And, it has the Wilson 2 kW power handling capability!

You can locate any of America's favorite
Wilson CB products at better dealers nationwide.

To complete your antenna system, use Wilson's crankup towers and rotors.

*Dual Parasitic Excitation field. DPE allows less energy to escape out the back or sides of the antenna.

Model antenna
not to scale



Specifications

- Gain: 14 dB over isotropic
- Front-to-Back Separation: 38 dB
- VSWR: 1.1 to 1, SWR adjustable
- Vertical-to-Horizontal Separation: 20/25 dB
- Power Handling Capability: 2 kW
- Power Multiplication: 28 times
- Bandwidth: Less than 1.5 to 1 over all 40 channels
- Windload Area: 6 square feet
- Boom Length: 16 feet
- Longest Element: 18 feet
- Weight: 28 pounds
- Recommended Rotor: Wilson WR-500
- Recommended Tower: All Wilson towers
- Quad Element: Fiberglass insulation

CB and Amateur Dealers Wanted.
New Dealers are needed for many areas of
the country. If you are interested, please
contact us.

Wilson Electronics Corp.

4288 S. Polaris Ave, P.O. Box 19000, Las Vegas, Nevada 89119
Phone 702-739-1931 • TELEX 684-522

C RCLE 98 ON READER SERVICE CARD

KENWOOD
...pacesetter in amateur radio

Here's a new and versatile accessory from Kenwood that belongs in every station. The AT-200 is an antenna tuner, but it's also much more. It's an antenna switch, an SWR bridge and an in-line wattmeter. The AT-200 reduces the clutter and increases the operating efficiency of your station... and at a surprisingly moderate price.

The AT-200 features a seven position rotary switch that selects 1 of 3 antennas and connects it through the antenna tuner circuit or directly to the transceiver. The 7th position allows you to connect a dummy load directly to your transceiver for tune up and testing. Two of the antenna inputs are fitted with SO-239 type coax connectors. A third input allows for easy hook up of a wire antenna with an impedance of 10 to 500 ohms. The AT-200 may be used on all HF amateur bands from 160 to 10 meters. It's handsomely styled to match the TS-820S and TS-520S Series (and TS-820 and TS-520), but can also be used with any HF transceiver or transmitter with less than 200 watts output.

Frequency Coverage: Amateur bands 1.8 to 30 MHz • Input Impedance: 10 to 500 Ohms • Maximum Power Capability: 200 watts • Insertion Loss: 0.5db • Power Meter: 20 watt/200 watt full scale • SWR Meter measures up to 10:1 • Dimensions 6-1/2" W x 7-3/8" D x 6-9/16" H • Weight: 6.2 lbs.

AT-200 WITH THE TS-820S



The MC-50 dynamic microphone has been designed expressly for amateur radio operation as a splendid addition to any Kenwood shack. Complete with PTT and LOCK switches, and a microphone plug for instant hook-up to any Kenwood rig. Easily switched for high or low impedance. (600 or 50k ohm).

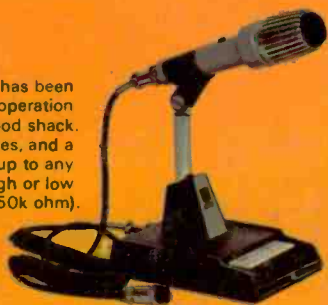

The TS-820S... still the Pacesetter. It has proven itself to be the performer we promised, proven itself through thousands of hours of operating time, worldwide and under the most difficult conditions. Unique features, superb specifications and top quality construction... all hallmarks of Kenwood amateur products are eminently displayed in the TS-820S. But then, you've probably heard all that on the air by now.

Trio-Kenwood Communications Inc.
1111 W. Walnut, Compton, CA 90220.

CIRCLE 99 ON READER SERVICE CARD