

February 1978 \$1.50

30 easy
projects complete
in this issue

modern electronics

©05707

13 projects under \$10

page 47

Shortwave receivers

page 68

7 winter weekend
projects

page 72

How ham
repeaters work

page 52

Videotape
recorders

page 64

SSB CB

page 58

Computerized
scanners

page 30

- how they work
- how to use them
- what they'll do for you

MICROCOMPUTERS

page 25



This Antenna is guaranteed clearer than any other

K40 no other antenna can claim all these features!

4 WHIP ADJUSTABLE OVER 2" for fine-tuning SWR—NO cutting!

5 METL-PLAS construction combines metal and plastic into one heterogeneous coil for highest permanent tolerances—less than 2% variance from antenna to antenna!

6 COMPUTER DESIGNED ISOLATION CHAMBER dampens static, provides clearer reception than ordinary solid inductance cores.

8 30° ROTATING BASE permits vertical adjustment on any angled surface.

9 FULLY ASSEMBLED with 18' of co-ax with in-line connectors for trouble-free mounting!

10 Optional UNIVERSAL MOUNT adapts for mounting anywhere you want it; mirror, luggage rack, gutter, etc.

Available direct from the manufacturer to dealer!

RUST PREVENTION—all metal components plated to MIL-SPEC QQ-C-320B, MIL-STD 868 and 870

1 RADIUSED 180° TIP provides static dissipation without requiring ball. No ball loss—ever!

3 FULL LENGTH 56" WHIP ground from 17-7PH Stainless Steel for 300% increase in signal-transmitting surface over 36" and 42" whips.

2 CRITICAL ASSEMBLY material and specifications adhere to U.S. Government Specs for mobile antennas (MIL-A-55288B-EL).

So unique—77 new patent claims pending or issued including U.S. Patent 3,626,051.

7 QUARTER-TURN QUICK RELEASE removes antenna from mount.

*DOUBLE GUARANTEE

GUARANTEE I: The K-40 will transmit farther and receive more clearly than the antenna it replaces or the customer will receive a prompt and full refund from the Registered K-40 Dealer who installed and tuned it.

GUARANTEE II: Materials and workmanship are guaranteed for a full 12 months. Any part that fails to perform satisfactorily will be replaced absolutely free.

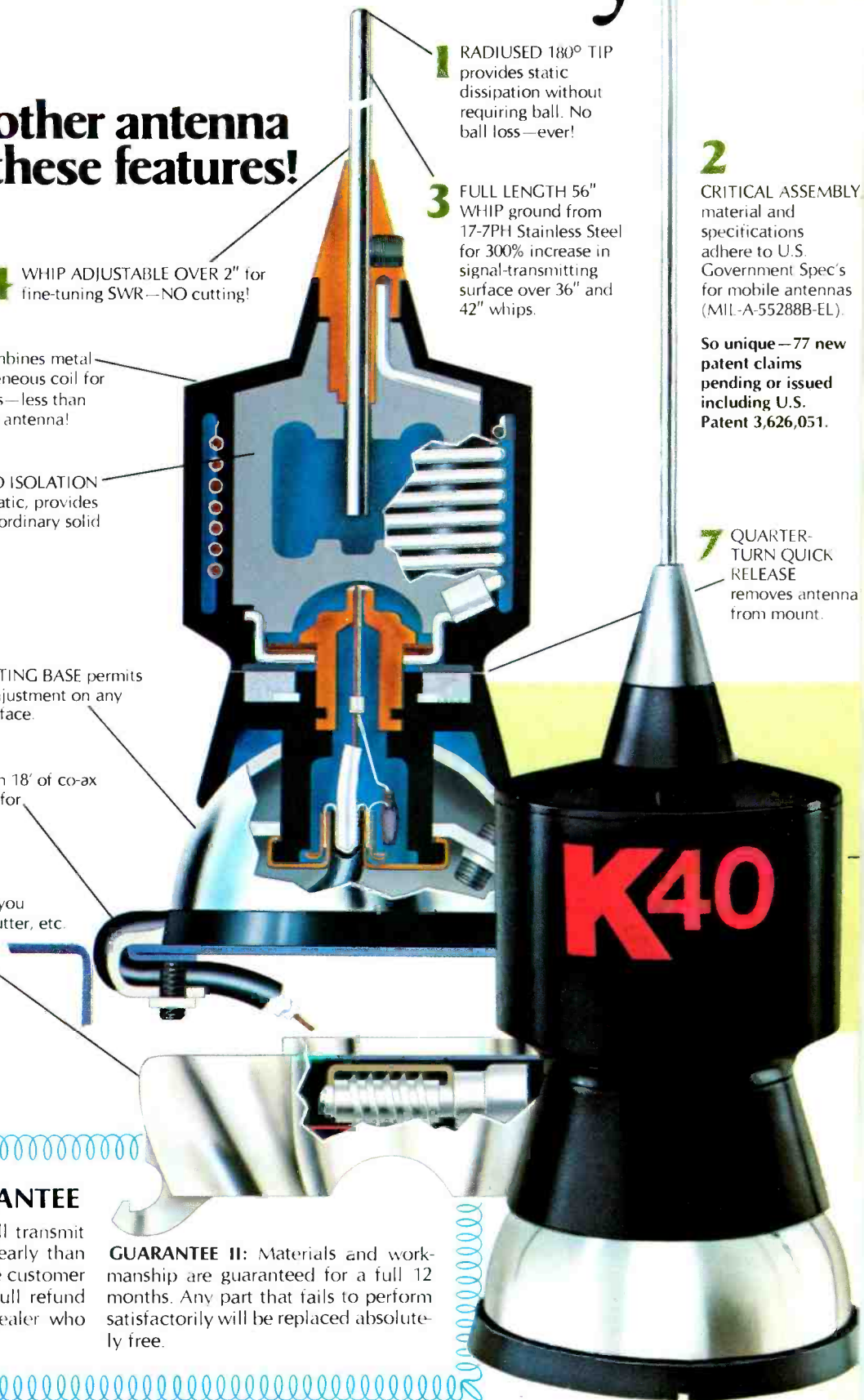

to transmit farther and mobile CB Antenna made!*

\$38.50 buys all this performance...
and wait'll you see it transmit!

Guaranteed more power! *This claim is made because we've tested it with hundreds of CB'ers in all fifty states for over one year! The K-40 was *conceived* in the Research Department of one of America's most innovative engineering companies... then *perfected* in the research labs of one of America's most respected universities and *proved* in actual use by 771 experienced CB'ers with 23 & 40 channel radios.

30% increase! *Average performance rated (VSWR and Efficiency combined) 30.5% better than all other brands tested, including Antenna Specialists, Avanti, Hy-Gain, Shakespeare, Turner, Newtronics, etc.

Equals full-length whip! The all-new K-40 was designed to equal or exceed the performance of a full-length whip—guaranteed to out-perform all other mobile antennas!

And it mounts anywhere!

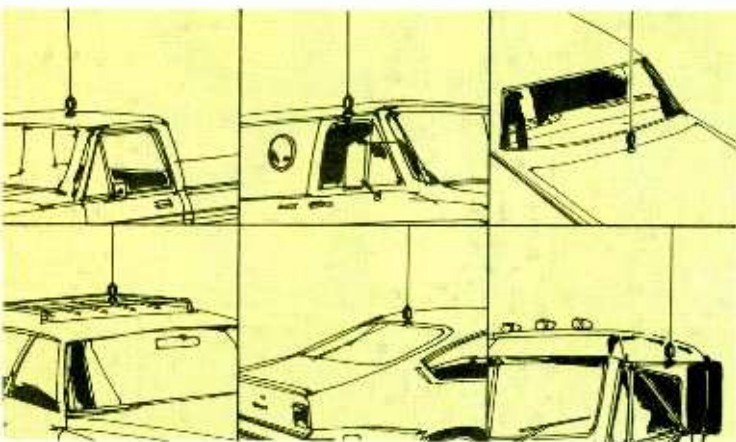

**See your local CB Dealer
for a demonstration.**

Here is what those CB'ers actually said:

K-40 vs. ANTENNA SPECIALISTS

"I'm a truck driver and I've been a CB'er for ten years. Compared to my Model M-410, "Big Momma," I recorded a 40% to 50% increase in transmission distance, clearer reception and a lower SWR by 20%. Frankly, the K-40 is the best antenna I've tried so far—over Antenna Specialists, Francis, Shakespeare, Hustler, Avanti—I tried them all."

John H. Collett, 207 McFee, Bastrop, Louisiana

K-40 vs. NEWTRONICS

"Compared to my XBLT-4, the K-40 can consistently transmit 40% further and the reception was better. I compared the two antennas using my Cobra Model #138 which has 69 channels. Quality is very good. I'd say the K-40 is the perfect way to complete any CB system."

Jerome R. Browne, 7800 S. Linder, Burbank, Illinois

K-40 vs. HY-GAIN

"I own a Volkswagen dealership and I've been a CB'er for over 12 years. I operate a TRAM XL5 with a Hy-Gain HELL CAT antenna that I've owned for over a year. The K-40 was better in reception with a measured SWR of 1.2. The K-40 was 20% better than the HELL CAT and transmitted 50% further."

Dale A. Dayden, 14 Barbara Dale Lane, Annapolis, Maryland

K-40 vs. FIBERGLASS

"I replaced my Francis with the K-40 and greatly improved my reception. The transmission was excellent, about a 30% improvement over my Francis. I talked well over 45 miles to an Astro Beam base. K-40's SWR of 1.1 was 10 to 20% better than my Francis!"

H. Ganse, 1964 Mt. Zion Road, York, Pennsylvania

K-40 vs. DUAL-ANTENNAS

"My twin Hustlers do not perform as well as the K-40. I got an improved performance on reception and about a 30% increase in transmit distance using the K-40. I've been a CB'er for 17 years, and I'd say it's superior to any other antennas."

James L. Andrews, P.O. Box 1509, Titusville, Florida

K-40 vs. WHIPS

"I'd rate the K-40 superior, although the transmission and reception of the K-40, compared to my 102" Antenna Specialist whip, was just about identical. I was able to tune the K-40 lower than my 102" whip. I think the K-40 is one of the best looking antennas on the market and overall, I'd rate the performance about as good as my 102" whip."

Daniel A. Rohlf, R.R. #2, Box 88, Binford, North Dakota

K40

American Antenna, 1945 South Street, Elgin, Illinois 60120

An All American Product from an All-American Company

CIRCLE 1 ON READER SERVICE CARD

Introducing the mobile that can move you out of the world of the ordinary and into the world of the serious CB'er. The Cobra 138XLR Single Sideband. Sidebanding puts you in your own private world. A world where there's less congestion. More privacy. More time to talk.



It's all possible because instead of 40 channels you get your choice of 120 channels. Both AM and SSB. And instead of 4 watts of legal power you get 12 watts of legal power. So you get almost double the range of AM.

With the 138XLR Single Sideband there's less background noise and less interference. So there's cleaner, clearer reception. Because like all Cobras, the 138XLR SSB is engineered to punch through loud and clear. Even in crowded metropolitan areas.

And like all Cobras it comes equipped with such standard features as an easy-to-read LED channel indicator. Switchable noise blanking and limiting. An RF/signal strength meter. And Cobra's exclusive DynaMike gain control.

You'll find the 138XLR SSB wherever Cobras are sold. Which is almost everywhere. Because Cobra's got a nationwide network of dealers and Authorized Service Centers offering sales, installation, service and advice. So come on in. And move on up.



Punches through loud and clear.

Cobra Communications Products
DYNASCAN CORPORATION
6460 W. Cortland St., Chicago, Illinois 60635

Write for color brochure
EXPORTERS: Empire • Plainview, N.Y. • CANADA: Atlas Electronics • Toronto

UPWARD MOBILITY.



CIRCLE 2 ON READER SERVICE CARD



modern electronics

FEBRUARY 1978

CONTENTS

VOLUME ONE NUMBER ONE

COVER STORY

40 Meet Mel, our friendly robot



A computer is as a computer does...

EDITOR
Anthony R. Curtis
K3RXK/W8TIZ

ASSISTANT EDITOR
Bob Margolin
K1BM/KAB6647

CONTRIBUTING EDITORS

Hans Fantel
Peter A. Stark
K2OAW

Gerald R. Patton
WA3VUP

Ron Cogan

Jeffrey A. Sandler

Judith G. Curtis
WB3AIQ/KIB2647

EDITORIAL ASSISTANT
Cathy McCaffrey

DESIGN CONSULTANT
Don Mannes

PUBLISHER
Richard A. Cowan
WA2LRO/KGB4096

Modern Electronics is published monthly by Cowan Publishing Corp. Our title is registered with the United States Postal Service. Application for controlled-circulation postage is pending at Port Washington, N.Y.

SPECIAL FEATURES

25 Microcomputers
now you can have your very own

64 Videotape recorders
piggybanks for time

34 Marine handhelds
talk from bridge to dinghy

30 Computerized scanners
search and lock on secret signals

52 Ham repeaters
how they work

68 Shortwave receivers
new radios top the old pros

78 Home study
13¢ stamp brings a new career

58 SSB CB
talk farther with the professional crowd



PROJECTS

47 13 projects under \$10

a baker's dozen fun things you can build in a night or weekend

55 4 op-amps

working with chips will take the mystery out of these simple integrated circuits

72 7 winter weekend warmers

do these indoors this Saturday

MONTHLIES

36 Gear
here's a colorful assortment of equipment you should know about

60 Handbook
resistance is easy

83 Program
monthly basic steps to computer fun

92 Puzzle
world's easiest electronics crossword

96 Newscheck
late news in the world of electronics

HOW TO

41 Choose your home computer

Pete tells how to shop for gear

81 Play computer chess

plts you against the smart board

COLUMNS

4 Comment
Tony writes on a clean slate

8 Mobile
Dave's in a world of electronics away from home

12 Computers
Pete explains where microprocessors come from

16 Clinic
readers try to stump the editors; score: readers 1, editors 10

18 Radio
Judy sees microcomputers in CB and ham gear

20 Stereo
Hans finds a microcomputer in a stereo receiver

87 How it works
Sharp tape deck has a micro brain

comment

OUTPUT FROM MODERN ELECTRONICS' EDITOR

BY ANTHONY R. CURTIS
EDITOR, MODERN ELECTRONICS

We have a clean slate. What shall we write on it?

Robots, microcomputers, ham radio, stereo, CB radio, short-wave listening, video recording, home and auto security, scanners and monitors, TV games, space electronics, test equipment, audio recording, marine electronics, radio control, even model railroad electronics. And scores of fun and exciting evening and weekend projects you'll be able to build with simple tools and easy-to-find parts.

These will be our stories. And much more, too. We'll cover everything in the world of electronics, revealing the mysteries, recounting the adventures, exploring the future.

Four kinds of articles will fill our pages:

- simple, inexpensive contemporary construction projects using readily available parts;
- reports and evaluations of useful new gear;
- easy-to-understand instruction in basic electronics;
- exciting accounts of the many different hobbies within electronics.

Projects will be useful, fun things for your computer, home, car, boat, plane, RV, model railroad, TV, ham radio shack, CB base station, stereo listening center, and workshop. They'll be inexpensive to build, and require parts which can be found anywhere.

Our columnists will explain their specialties and give you inside tips on how to get the most from your electronic gear, tools, and parts:

- Hans Fantel, stereo editor for the *New York Times* and widely-read author of audio books and articles, each month will lend insights into sound recording and playback, stereo disc, tapes and gear, and other parts of the audio field.
- Pete Stark, one of the top writers today in personal microcomputers for the home, each month will help you get into this exciting new field. Computers seem to be everywhere today. In a short few years from now, they will be in every home and car. Pete will lay the foundation so you can understand how microprocessors work, what they can and can't do and where we all are going in our digital yellow submarine.
- Judy Curtis, author of national magazine articles about radio and co-author of the current edition of the novice license training package, *Tune In The World With Ham Radio*, from the American Radio Relay League, will open up exciting new vistas in radio communications. She will explore the fun of CB; describe the public service, professionalism and exhilaration of ham radio; scrape away the barnacles for a better look at modern marine two-way radio; open up new avenues of discovery in the grand old hobby of shortwave listening; and crack the secret world of scanners and police monitoring.
- Modern Electronics' editors will answer your technical questions in *Clinic*.
- Each issue we'll supply a new *Computer Program of the Month*, designed to run in Basic on one or more currently-popular machines.
- Our *Handbook* will be an electronics shortcourse made easy. A small package of theory will be opened each month, examined, explained and tucked away for your future reference. You'll learn, month after month, about resistance, capacitance, inductance, power supplies, transformers, diodes, transistors, tubes, and integrated circuits in an easy-to-understand form.

And, there will be lots more. Too much, in fact, to recount here. Our plans are extensive and thorough. I hope you'll tune in each month to see what we're up to!

modern electronics

Business Staff

President and Publisher
Richard A. Cowan
Associate Publisher
Richard A. Ross
Vice President
Jack N. Schneider
Chairman of the Board
S. R. Cowan

Advertising Staff

Display Advertising
Richard A. Cowan
telephone (516) 883-6200
Advertising Manager
Bill Edwards
telephone (603) 924-3360
Midwest Sales Director
Jim Reilly
telephone (312) 824-2412
Classified Advertising
Cathy McCaffrey
telephone (516) 883-6200
Circulation Manager
Janet Kurtz
Production Consultant
Cary L. Cowan

Art Staff

Art Director
William H. Travis
Assistant Art Director
Liz Beener
Design
Sheryl Stern
Illustrator
Harold Perry
Staff Artist
Fran Vitrano
Staff Artist
Tom Batcher

Property rights

All circuits, designs and construction projects in Modern Electronics are strictly experimental. We can't guarantee any results to be expected from their use or application. The publisher and editors do not know of any proprietary rights which could be violated by the making, building or using of any projects or gear described in this issue.

Freelance writers

Letters to the editors should be addressed to Modern Electronics, 14 Vanderventer Ave., Port Washington, NY 11050. Our editorial telephone is (516) 883-6200. We can't assume responsibility for unsolicited manuscripts but we will try to handle them courteously. Please mark your name, address and telephone number clearly on each page of manuscripts and on all photographs and artwork. Modern Electronics' readers demand manuscripts, photographs and artwork of the finest quality. Writers, photographers and artists meeting the standards of Modern Electronics' editors will receive prompt professional payment for submissions upon acceptance.

Change of address

Send us word of your change of address as early as possible. We need at least six weeks to make the change in our mailing list. Address changes and Postmaster form 3579 to Circulation Department, Modern Electronics, 14 Vanderventer Ave., Port Washington, NY 11050. Include your old address, new address and a mailing label from a recent issue of Modern Electronics.

Subscriptions

Mail subscriptions are available for \$12 a year or \$22 for two years. Newsstand cover price is \$1.50 per issue. Subscriptions are slightly higher for other countries. Write Circulation Department, Modern Electronics, 14 Vanderventer Ave., Port Washington, NY 11050. This magazine is printed in the United States of America.

Copyright

Copyright to the whole contents of Modern Electronics is held by Cowan Publishing Corp. 1978. You may not reprint any of our material without written permission from Cowan Publishing Corp.

Quick kick in the set

Turner offers the quickest and easiest steps to better CB performance. To start with, make sure your set has the advantages of a Turner antenna. Attention to such details as a spring-loaded cable-to-coil contact do away with intermittent signal problems and potential VSWR damage to your set.

The die-cast metal base, molded coil cover structure and heavy-duty stainless-steel parts assure you

of an antenna that's built for a tough life on the streets.

Then, to be certain that your set has enough audio input to give you all the "talk power" it is designed to deliver, treat your CB to a Turner mike. Models with audio input preamp, volume control, speech compression and noise cancelling can do wonders for any CB set.

Find out what your CB set has been missing. See a Turner dealer. For kicks.

Turner, 716 Oakland Road N.E., Cedar Rapids, Iowa 52402.

TURNER
MICROPHONES
ANTENNAS

Signal
Kicker

TURNER
ROAD-KING 70

CIRCLE 5 ON READER SERVICE CARD

CDNRAC
CORPORATION



Preparation
of this premier issue of
Modern Electronics
was done by
REGENCY LITHO INC.
22 West 21 Street
New York, New York 10010
(212) 929-4610

separating=prep=plating=printing

Our *Sheer Color Scan Inc.* division
can give you full service
with the first Magnascan 510
electronic scanner for
color separations
in New York City

CIRCLE 100 ON READER SERVICE CARD

Application Software!

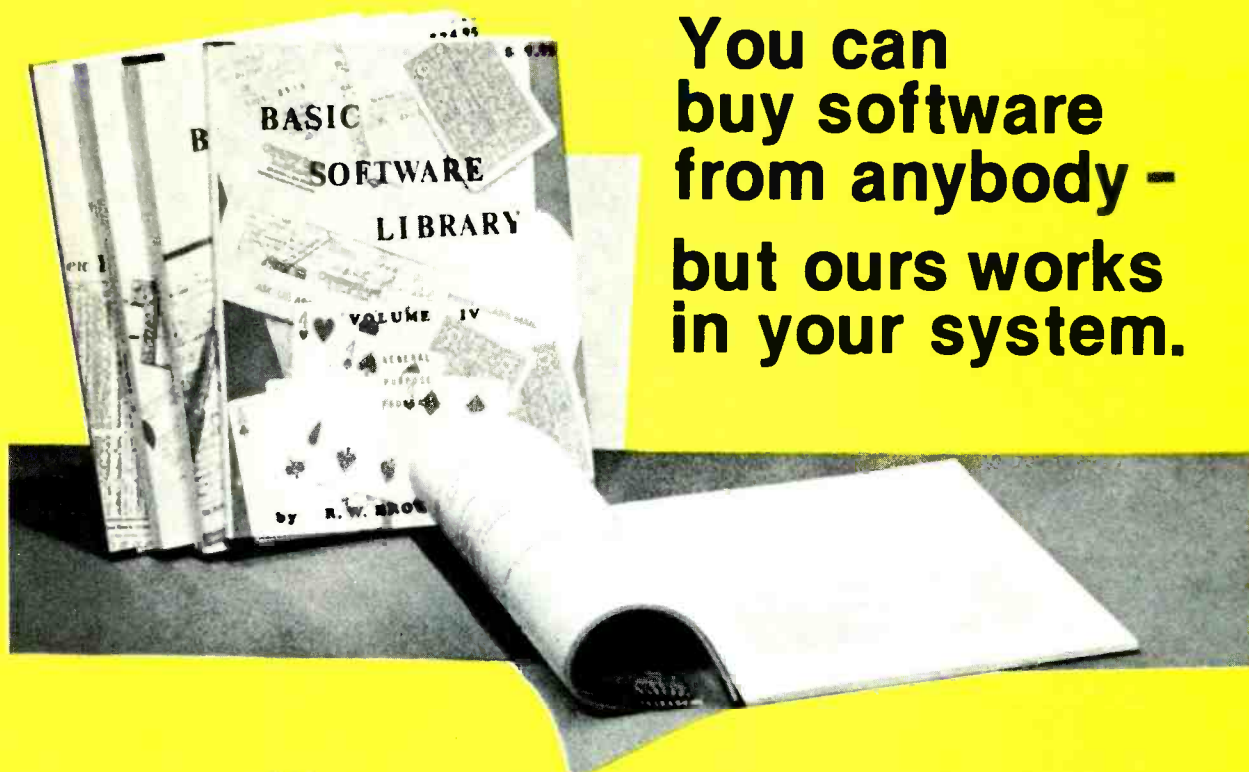

You can
buy software
from anybody -
but ours works
in your system.

We only sell one product, Quality.

We have been in business for over nine years building a reputation for providing a quality product at nominal prices — NOT what the traffic will bear. Our software is:

- **Versatile** — as most programs allow for multiple modes of operation.
- **Tutorial** — as each program is self prompting and leads you through the program (most have very detailed instructions contained right in their source code).
- **Comprehensive** — as an example our PSD program not only computes Power Spectral Densities but also includes FFT's, Inverse-transforms, Windowing, Sliding Windows, simultaneous FFT's variable data sizes, etc. and as a last word our software is:
- **Readable** — as all of our programs are reproduced full size for ease in reading.
- **Virtually Machine Independent** — these programs are written in a subset of Dartmouth Basic but are not oriented for any one particular system. Just in case your Basic might not use one of our functions we have included an appendix in Volume V which gives conversion algorithms for 19 differ-

ent Basic's; that's right, just look it up and make the substitution for your particular version. If you would like to convert your favorite program in to Fortran or APL or any other language, the appendix in Volume II will define the statements and their parameters as used in our programs.

Over 85% of our programs in the first five volumes will execute in most 8K Basic's with 16K of free user RAM. If you only have 4K Basic, because of its' lack of string functions only about 60% of our programs in Volumes I thru V would be useable, however they should execute in only 8K of user RAM.

Future additions:

Soon to be released! A "fantastic" word processing package set up for lawyers, publishers and writers; and a Medical Billing system which will also allow a patients record to be individually scanned. AND there are rumors that a 12K chess game, in Basic, will also be released.

Volumes VI and VII available on our Firmware System.

Vol. I — \$24.95

Bookkeeping
Games
Pictures

Vol. II — \$24.95

Math/Engineering
Plotting/Statistics
Basic Statement
Def.

Vol. III — \$39.95

Advanced Business
Billing, Inventory
Investments
Payroll

Vol. IV — \$9.95

General Purpose

Vol. V — \$9.95

Experimenter's
Program



SCIENTIFIC RESEARCH

220-M Knollwood, Key Biscayne, FL 33149

Phone orders call (305) 361-1153

Information and Maryland residents call (301) 721-1148

Add \$1.50 per volume handling, all domestic shipments sent U.P.S. except APO and P.O. Box which go parcel post. Foreign orders add \$8.00/volume for air shipment and make payable in U.S. dollars only.

AVAILABLE AT MOST COMPUTER STORES

Master Charge and Bank Americard accepted.

Our Software is copyrighted and may not be reproduced or sold.

CIRCLE 7 ON READER SERVICE CARD

BY DAVE SCOTT

Boats, planes, cars and RVs are more fun when you plug into the 12-volt dc world of electronics away from home.

There was a good 5 knot wind filling the sails as we scuttled down the Chesapeake Bay toward the horn at Bloody Point. We had long since passed Thomas Point Lighthouse which squats like a splendid white spider surveying the bay outside Annapolis harbor. The spider was lost from view and the rhyth-

mic bellowing of the horn was faint in the distance when the marine radio began to crackle on emergency channel 16.

"Annapolitan I, WYN 555, to Annapolitan. Go to channel 30."

Over marine channel 30 we could hear Annapolitan I, returning from a

day cruise to St. Michael's, MD, report engine trouble and ask for instructions.

"Should we attempt to fix the one boiler here in the middle of the bay or should we try to make it home? We have a full load of passengers, if anything should go wrong..."

"This is Annapolitan. We cannot read you; cannot read you. You're breaking up."

The exchange went on for a couple more transmissions before I realized I could hear both the ship and its home base, full quieting. The pleasure cruiser was far enough down the bay to be out of range over the VHF marine band, where all transmissions are line of sight. But I was equidistant between the two. I grabbed the mic.

"Break. This is WYN 2260. Can I relay, Annapolitan I?"

Contact was made and Annapolitan I was ordered to limp home and make repairs there. The possible danger to passengers was too great to try anything in the middle of the bay.

Whether you're maritime mobile, aero mobile or foot mobile in the Rocky Mountains, you are never out of touch via radio.

On the waves

Boaters are assigned the frequencies between 156-164 MHz in the radio spectrum. Channel 16, the international distress, safety and calling frequency, is 156.8 MHz. There are 55 channels in this slice of the band, 14 of which the average boater would use. Many boaters have synthesized rigs, however, and listen in on activity on all channels, even though they must not transmit over all 55.

Several marine channels are set aside for ship-to-shore telephone calls. A marine operator can connect a boater with anyone ashore via his marine radio. Boaters also monitor two frequencies set aside for continuous National Weather Service broadcasts at 162.4 MHz and 162.55 MHz.

These frequencies are in the very high frequency (VHF) portion of the spectrum. Boaters used to communicate in

please turn to page 22



When the fish aren't biting, Charlie Myers can watch the ball game on tv. Charlie mounted on his camper a flying-saucer shaped RCA tv antenna. The Mini State antenna is powered by the 12-volt battery in his recreational vehicle. A hand-held remote control lets him point the antenna electronically for the best tv signal. It also operates from 120-volt ac house power when Charlie is home.



NRI CAN TURN YOUR CB INTEREST INTO PART-TIME INCOME OR A CAREER

Career opportunities are opening up fast for the man trained in communications.

The field of communications is bursting out all over. In Citizens Band alone, class "D" licenses grew from 1 to over 2.6 million in 1975, and the FCC projects about 15 million U.S. CB'ers by 1979. That means a lot of service and maintenance jobs . . . and NRI can train you at home to fill one of the countless career jobs available in design, installation and maintenance of communications equipment. Start training now, the NRI way, to get your all important FCC Radiotelephone License and qualify for one of these openings.

Learn on your own 400-channel, digitally-synthesized VHF transceiver

The NRI Complete Communications Course teaches you at home to service and adjust all types of two-way radio equipment (including CB), using the one unit that is best equipped to train you for CB, Commercial and Amateur communications: a digitally-synthesized 400-channel VHF transceiver

and AC power supply. This 2-meter transceiver gives you "Power-On" training. Then we help you get your FCC Amateur License with special instructions so that you can go on the air.

More know-how for your dollar

The complete program includes 48 lessons, 9 special reference texts, and 10 training kits. Included are: your own electronics Discovery Lab, a new Antenna Applications Lab, an Optical Transmission System, CMOS Digital Frequency Counter, and TVOM. The course covers AM and FM Transmission Systems; Radar Principles; Marine, Aircraft, and Digital Electronics and Mobile Communications. You must earn your first class radio-telephone FCC license or you get your money back.



CB Specialist Course also available

NRI offers a specialized course in CB Servicing. You get 37 lessons, 8 reference texts, your own CB transceiver, AC power supply and multimeter . . . for hands-on training. Also included are 14 coaching units to make it easy to get your commercial radiotelephone FCC license, enabling you to test, install and service communications equipment.

Widest choice of courses with Quadraphonic Audio and Color TV Servicing

NRI offers five TV-Audio servicing courses as well as career courses in Digital Computer Electronics; Marine and Aircraft Electronics; Mobile Communications, and more.

Over a Million have enrolled with NRI

Send for the free NRI catalog and discover why more than a million people like yourself have chosen the NRI way as the right way to get ahead. Read how you learn at home from bite-size lessons, progressing at your own speed to your FCC license and then into the communications field of your choice. There's no obligation, and no salesman will call.



If card is missing, write to:



NRI SCHOOLS
McGraw-Hill Continuing
Education Center
3939 Wisconsin Avenue
Washington, D.C. 20016

CIRCLE 9 ON READER SERVICE CARD

We're changing the world of sound.

Man has always
had an ear for
new experiences.

From the distant thunder of the sea in an ornate shell... to the advanced communications systems of today.

Now, Palomar Electronics introduces the SSB-2900. A 40 Channel AM/Single Sideband 2-way radio that is the most advanced C.B. you can buy. Send for a free data sheet... or see it at your nearby dealer. Check the specs... compare performance with any other 2-way radio... and you'll see why Palomar Electronics calls the SSB-2900 the "State of the art... future tense".

It's the best C.B. around, for those with a real ear for it.

FREE SEA SHELL POSTER



Send for a Spec Sheet on
the Palomar SSB-2900 and
receive this beautiful
4-cc or, 22"x30" poster
... FREE



PALOMAR Electronics Corporation
We're Wired for Progress!

665 Upper Street, Encinitas, Calif. 92025 • Telephone: (714) 436-2660
CIRCLE 10 ON READER SERVICE CARD

IF YOU'RE WAITING FOR SOLDERLESS BREADBOARDS TO BE FASTER, EASIER, MORE VERSATILE AND LOWER-PRICED...

Incredibly inexpensive. EXPERIMENTOR solderless sockets begin at \$5.50* (\$4.00* for the 40 tie-point quad bus strip). A spool of solder costs more.

Mix and match. Use large and small chips in the same circuit without problems. There are two sizes of EXPERIMENTOR sockets with 0.3" and 0.6" centers.

Full fan-out. A CSC exclusive. The only solderless breadboard sockets with full fan-out capabilities for **micro-processors** and other larger (0.6") DIP's.

Microprocessors and other complex circuits are easy to develop. Each EXPERIMENTOR quad bus gives you four bus lines. By combining quads, 8-, 12- and 16-line address and data buses can be created, simplifying complex data/address circuits.

Infinitely flexible. Circuits can go in any direction, up to any size. All EXPERIMENTOR sockets feature positive interlocking connectors that snap together. Horizontally and/or vertically. And un-snap to change a circuit whenever you wish.

Easy Mounting. Use 4-40 screws from the front or 6-32 self-tapping screws from the rear. Insulated backing lets you mount on any surface.

EXPERIMENTOR 350. \$5.50* 46 five-point terminals plus two 20-point bus strips. 0.3" centers; $\frac{3}{8}$ x 3 $\frac{1}{2}$ x 2"

EXPERIMENTOR 650. \$6.25* 46 five-point terminals plus two 20-point bus strips. 0.6" centers; $\frac{3}{8}$ x 3 $\frac{1}{2}$ x 2 $\frac{1}{4}$ "

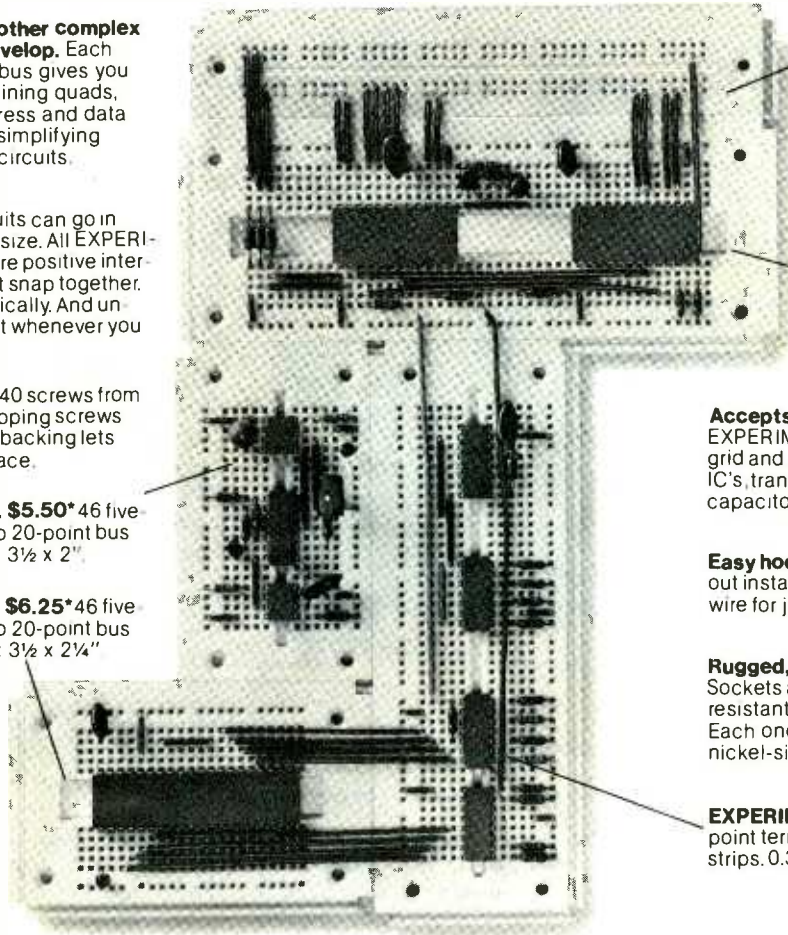

EXPERIMENTOR QUAD BUS STRIP \$4.00* Four 40-point bus strips. $\frac{3}{8}$ x 6 x $\frac{3}{4}$ "

Designated tie-points. Simplify translation from breadboard to PC-boards or wiring tables.

EXPERIMENTOR 600. \$10.95* 94 five-point terminals plus two 40-point bus strips. 0.6" centers; $\frac{3}{8}$ x 6 x 2 $\frac{1}{4}$ "

Accepts all standard components. EXPERIMENTOR sockets conform to an 0.1" grid and are DIP compatible. Also accept IC's, transistors, diodes, LED's, resistors, capacitors, transformers, pots, etc.

Easy hookup. Components push in and pull out instantly. Use #22-30 solid AWG wire for jumpers.

Rugged, dependable construction. Sockets are constructed from abrasion resistant materials and withstand 100°C. Each one features non-corrosive nickel-silver contacts.

EXPERIMENTOR 300. \$9.95* 94 five-point terminals plus two 40-point bus strips. 0.3" centers; $\frac{3}{8}$ x 6 x 2"

WHAT ARE YOU WAITING FOR?

Discover today how solderless breadboarding can save time and money on every circuit you build. Get acquainted with EXPERIMENTOR™ sockets* and how they simplify circuit design, assembly and testing. Eliminate the hassles and component damage of soldering. No special hardware or jumper cables required, either. And the price is so low, it's hard to believe.

See your CSC dealer today. Or call 203-624-3103 (East Coast) or 415-421-8872 (West Coast) for the name of your local stocking distributor and a full-line catalog.

CONTINENTAL SPECIALTIES CORPORATION



70 Fulton Terrace, Box 1942, New Haven, CT 06509, 203-624-3103 TWX 710-465-1227
WEST COAST: 351 California St., San Francisco, CA 94104, 415-421-8872 TWX 910-372-7992
GREAT BRITAIN: CSC UK LTD., Spur Road, North Feltham Trading Estate,
Feltham, Middlesex, England, 01-890-8782 Int'l Telex: 851-881-3669

*Manufacturer's recommended resale.
© 1977, Continental Specialties Corporation

†U.S. Patent No. D235,554

computers

HOW THEY WORK,

HOW YOU USE THEM, WHAT THEY CAN DO FOR YOU

BY PETE STARK

Everyman's home computer is on the shelf now at your local computer store. Where did it come from? Where is it going?

With the coming of a new magazine and a new column, it is traditional to outline where we're going and what's ahead. But even if we were already here and steaming along, it would be a good idea to occasionally slow down to let the stragglers catch up. So it seems particularly appropriate to introduce you to the subject of this column: the *computer*. So many people only know of him as the chap who prints DO NOT FOLD, SPIN-

computer can also be the box deep inside a penny arcade game, the small integrated circuit chip inside a CB transceiver, or the large box on the hobbyist's workbench. This column will deal with all of those, though with emphasis on the smaller computers rather than the large ones for the simple reason that the very large computers are only accessible to the computer professional, whereas the smaller computers are all around us.

also *written* into it during normal computer operation. ROM also has numbers written into it, but the writing is done during manufacture or installation, and only reading is done during normal operation. The words writing and reading are commonly used to mean storing data in a memory and then getting it back.

The memory can store three types of *data*—numbers which are needed in various calculations, letters and punctuation marks involved in alphabetic problems such as updating a mailing list, and instructions which guide the computer through a problem from start to end.

More Compact

The instructions make up the *program*. During normal computer operation, the CPU will read one instruction out of memory at a time and send it to the control unit. Here the meaning of the instruction (which was coded in memory as a series of numbers) is decoded and the control unit sends the appropriate electrical control signals to the rest of the computer to cause that instruction to be done. Typical instructions might cause a number to be sent from memory to the ALU, or perhaps add that number to the number already in the ALU, or might send the answer back to memory. Each of these instructions is very primitive and many such instructions are needed to solve even a simple problem. The utility of the computer comes from the fact that these instructions can be performed very rapidly at rates up to 10 million per second in some cases.

Together, the central processing unit and its memory can act as a workable computer to solve problems. To be useful, though, *input* and *output* devices, and their interconnection circuitry called *interfaces*, have to be added. The interfaces are also controlled by the CPU to synchronize their operation with the rest of the system. When more than one input or output device is used, then each device has its own interface.

Some interfaces, especially those which are used with complex input or output devices such as tape or disc drives, are called *controllers* to point out

please turn to page 22



Here's where it all started a couple of years back. MITS Altair 8800 was the first micro-computer sold to hobbyists.

DLE, OR MUTILATE on their utility bills.

The history of computers starts in many places, depending on how far back you want to go. One can start with the abacus of the Far East, or with Pascal's calculator of 1642, or with Babbage's differential engine of 1820, or any one of a thousand other milestones. The simple fact is that today's computer is as much the product of a few large advances as it is of thousands of small improvements added over the years. Even today, when we think of a computer, we think of many different systems.

The traditional computer is the large brain, most often painted a pretty IBM Blue, which resides in an air-conditioned room, its wires neatly hidden beneath a false floor, and a large picture window facing the hallway so all who pass can be suitably impressed. But the

All computers have certain similarities and consist of similar functional units. The heart of any computer is the *CPU* or Central Processing Unit. This contains the control circuitry which operates all of the other computer parts, and synchronizes them so they work well together. Also in the CPU is the *ALU* or Arithmetic and Logic Unit. The ALU can perform certain simple arithmetic operations such as addition or subtraction, as well as some logical operations such as testing a number to see whether it is positive, negative, or zero.

Mostly alike

Connected to the CPU is the *memory* which can consist of various combinations of RAM (Random Access Memory) and ROM (Read Only Memory).

RAM memory differs from ROM in that data can be not only *read* from it but

Now you can communicate with the President!

Communicating with the President is easy. No red tape. No hassle. In fact, the President hot-line is TOLL FREE! Why? Because this year there's more and more CBer's who won't settle for anything but the best. Best performance. Best price.

President is the CBer's CB. Every model is designed for 40 channels. Every President



comes with everything you'd expect on a top-of-the-line CB-plus sophisticated features you'd expect to pay extra for. And every single President unit is tested for top performance before you get it. You get the best, and only the BEST!

And, best of all, you get a super price! A price so low, we're afraid President's president may not like our president any more.



PRESIDENT
Engineered to be the very best.

Toll Free:
800-558-5151
In Wisconsin 800-242-7010

ECHO®

COMMUNICATIONS, INC./CEDARBURG, WI 53012

CIRCLE 13 ON READER SERVICE CARD

MICROCOMPUTER

MICROPROCESSOR'S

F-8	19.95
Z-80	25.00
Z-80A	35.00
CDP1802CD	24.95
AM2901	22.95
6502	12.95
6800	19.95
8008-1	8.75
8080A	15.95
TMS-9900TL	89.95

6800 SUPPORT

6810P	4.95
6820P	8.00
6828P	11.25
6834P	16.95
6850P	9.95
6852P	11.95
6860P	14.95
6862P	17.95
6880P	2.70

Z80 SUPPORT DEVICES

3881	12.95
3882	12.95

F-8 SUPPORT DEVICES

3851	14.95
3853	14.95

DYNAMIC RAMS

1103	1.50
2104	4.50
2107A	3.75
2107B	4.50
2107B-4	4.00
TMS4050	4.50
TMS4060	4.50
4096	4.50
4116	42.00
MM5270	5.00
MM5280	6.00
MCM6605	6.00

CHARACTER GENERATORS

2513 UP	6.75
2513 DOWN	6.75
2513 UP (5v)	9.95
2513 DOWN(5v)	10.95
MCM6571	10.80
MCM6571A	10.80
MCM6572	10.80
MCM6574	14.75
MCM6575	14.75

PROM'S

1702A	5.00
2704	15.00
2708	20.00
2716	38.00
3601	4.50
5203AQ	4.00
5204AQ	6.00
6834	16.95
6834-1	14.95
82S23B	4.00
82S129B	4.25
8223B	2.70

8080A SUPPORT DEVICES

8212	3.95
8214	9.95
8216	4.50
8224	4.95
8228	8.75
8238	8.00
8251	12.00
8253	28.00
8255	12.00
8257	25.00
8259	25.00

STATIC RAMS

	1-24	25-99	100
21L02 (450)	1.50	1.40	1.25
21L02 (250)	1.95	1.80	1.50
21L11	4.25	4.10	3.95
1101A	1.49	1.29	1.10
2101-1	2.95	2.75	2.60
2102	1.25	1.15	1.00
2102-1	1.50	1.30	1.15
2111-1	4.00	3.50	3.25
2112-1	3.00	2.80	2.69
2114	17.95	16.95	16.50
31L01	2.50	2.35	2.00
3107	3.95	3.70	3.25
4200A	12.95	12.50	11.95
4804/2114	17.95	16.95	16.50
5101C-E	11.95	11.25	10.25
74C89	3.25	3.05	2.85
74S201	4.50	4.30	4.25
7489	2.25	2.10	1.90
8599	1.88	1.75	1.60
9102BPC	1.65	1.45	1.30

KEYBOARD CHIPS

AY5-2376	13.95
AY5-3600	13.95

UART'S

AY5-1013A	5.50
AY5-1014A	8.95
TR-1602A	5.50
TMS-6011	6.95
IM-6402	10.80
IM-6403	10.80

FLOPPY DISC CONTROLLER

1771B	55.95
1771B-01	59.95

SHIFT REGISTERS STATIC

2518B	3.95
2533V	2.00
TMS3002	1.00
TMS3112	3.95
MM5058	2.00

KIM

KIM-1	245.00
6502	12.95
6520	9.00
6522	9.25
6530-002	15.95
6530-003	15.95
6530-004	15.95
6530-005	15.95

USRT

S-2350	10.95
WD1671B	29.95

WAVEFORM GENERATOR

8038	4.00
MC4024	2.50
566	1.75

MISC. OTHER COMPONENTS

NH0025CN	1.70	P-3408A	5.00
NH0026CN	2.50	P-4201	4.95
N8T20	3.50	MM-5320	7.50
N8T26	2.45	MM-5369	1.90
74367	.90	DM-8130	2.90
DM8098	.90	DM8131	2.75
1488	1.95	DM-8831	2.50
1489	1.95	DM-8833	2.50
D-3207A	2.00	DM-8835	2.50
C-3404	3.95	SN74LS367	.90
		SN74LS368	.90

TV

Game Chip
TMS1955NL
Now Only
\$10.95

PerSci DISK AND CONTROLLER

Use the PerSci Disk and Controller now with the Info 2000 Adapter for the S-100 Bus.

INFO 2000 "SPECIAL"

(includes Model 277 Dual Drive, Model 1070 Controller, Case with power supply and fan, and cable)

Model 277 Dual Diskette Drive	\$2,150
Model 1070 Controller	\$1,130
Model 1070 Controller	\$740
Slimline case with power supply and fan	\$280
Adapter for the S-100 Bus (Kit)	\$120

JADE PARALLEL/SERIAL INTERFACE KIT

\$124.95 KIT

JADE

VIDEO INTERFACE KIT

\$89.95 KIT

8K STATIC RAM BOARD

ASSEMBLED & TESTED

250ns.	\$199.95
350ns.	\$189.95
450ns.	\$169.95

- * WILL WORK WITH NO FRONT PANEL
- * FULL DOCUMENTATION
- * FULLY BUFFERED
- * S100 DESIGN
- * ADEQUATELY BYPASSED
- * LOW POWER SCHOTTKY SUPPORT IC'S

KIT

250ns.	\$169.95
350ns.	\$139.95
450ns.	\$129.95

MSAI/ALTIR S-100 COMPATIBLE

JADE Z80 KIT

—with PROVISIONS for ONBOARD 2708 and POWER ON JUMP

\$135.00 EA. (2MHZ)

\$149.95 EA. (4MHZ)

BARE BOARD \$35.00

MSAI/ALTIR S-100 COMPATIBLE

JADE 8080A KIT

— WITH EIGHT LEVEL VECTOR INTERRUPT

\$110.00 KIT

BARE BOARD \$35.00

JADE

Computer Products

5351 WEST 144th STREET
LAWDALE, CALIFORNIA 90260
(213) 679-3313

RETAIL STORE HOURS M-F 9-7 SAT. 9-5
Discounts available at OEM quantities. Add \$1.25 for shipping. California residents add 6% sales tax.

CATALOG FREE WITH \$10.00 ORDER J6

BY JEFF SANDLER

Put you in the pix

A friend of mine has an expensive 35 mm camera that has a built-in timer that lets him get into his pictures. I have an inexpensive camera that doesn't have a timer, but I'd like to get into my pictures, too. Is there any way I can build a timer for my camera?

B.L., Peducha, KY

The circuit shown below should fill the bill. The camera gets tripped after the adjustable

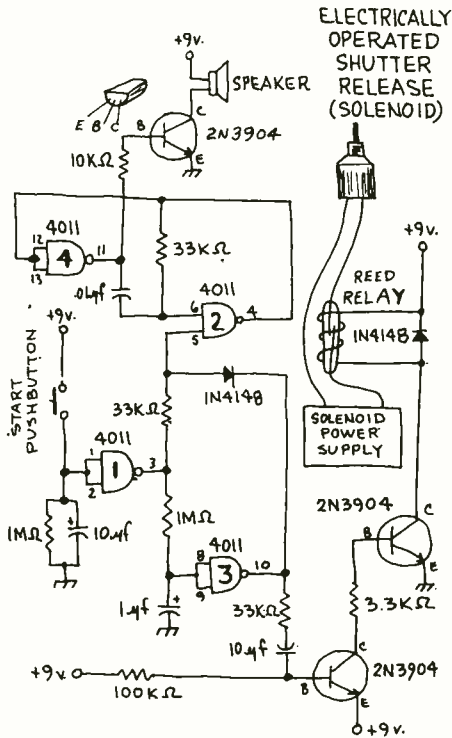

time delay has expired, but not before an audible "smile" warning sounds. You can also use the circuit as a darkroom timer.

Unfry your transmitter

I'd like a warning when my CB antenna SWR goes above 2:1 so I don't cook the transmitter. Can you make an LED light up, above 2:1?

F.S., Tadpole, WV

Unfortunately, you won't be able to get away with just connecting an LED to the SWR meter. There's just not enough signal there to light it up. But, using an inexpensive op-amp, you can make a visual SWR monitor. Best part of this circuit is that by adjusting

the variable resistor, you can preset the SWR at which the LED lights.

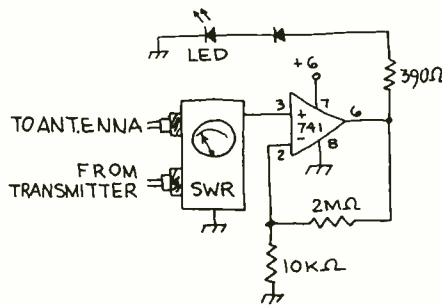

Car radio needs help

I just bought an am-fm car radio for my pickup truck. The fm works great, but the am reception is very poor. Unless I'm very close to the station, about all I get is a lot of ignition noise. I always thought am signals traveled much further than fm. So why can't I get am stations as far as I can get fm stations?

R.A., East St. Louis, IL

You're right about the relative reception distances of am and fm broadcasts; am should be heard much farther from the transmitter than fm. Based on your description, it sounds as if you forgot to adjust the antenna trimmer in the radio. Without properly setting the trimmer, the antenna is so poorly matched to the radio that very little of the am signal is actually fed into the radio itself. To set the trimmer, tune the radio to a weak signal about 1400 on the am dial. Then adjust the trimmer to the point at which the signal is the loudest. However, you may have a little difficulty finding the antenna trimmer. For some reason, the manufacturers like to hide it in out of the way places, like under the volume control.

Eliminate rat's nest

Back when I was a kid, electronic circuits were easy to build. All the parts were large, and the chassis big enough for roomy layouts. It's different today. The same circuit I used to build in 12" x 15" chassis is now built on a 3" x 5" printed circuit board. I'm just not used to all this miniaturization. My boards look like a rat's nest. Is there any trick I

can use to make the boards look better?

T.J.Q., Walla Walla, WA

Here's a trick I've used quite successfully for some time. Instead of using ordinary hook-up wire, which is rather thick, I use Vector wiring for over the board connections. The insulation used is designed to burn off from the heat of a soldering iron, but only at the spot the heat is applied. The insulation remains intact elsewhere on the wire, so there's no chance of a short circuit developing. It's amazing how the smaller gauge wire can condense that rat's nest you mentioned. In almost all cases, the slight increase in resistance due to the smaller wire gauge will not affect the circuit in any way.

Your purse is ringing

About a month ago, my wife had her purse stolen. Yesterday, it happened again. Isn't there some kind of alarm I could build into her purse that would sound when the purse was grabbed by a thief?

J.H., Los Angeles, CA

The alarm circuit shown below should solve your problem. As long as your wife is holding the handle or strap, the alarm remains quiet. However, if the purse is grabbed so that the handle is not held for about 30 seconds, the alarm goes off. The alarm is built around a compact, battery operated "bicycle

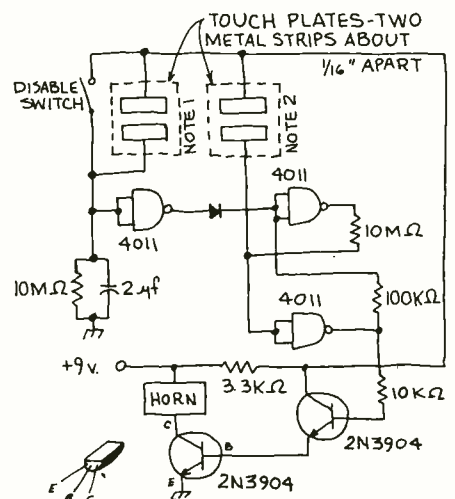

- NOTES:
1. ON STRAP-HAND MUST TOUCH BOTH PLATES OR ALARM SOUNDS.
 2. HIDDEN RESET TOUCHPLATE - TURNS ALARM OFF WHEN TOUCHED.

horn." The horn and circuit are small and light enough to fit into the bottom of the purse. The sound of the horn should be loud enough to wake the dead. Do me a favor. Write and let me know how it works. Be sure to describe the look on the thief's face when he gets caught.

Where's the #@*% switch

My kid is always leaving his toys all over the house. Hardly a night goes by that I or my wife doesn't step on something. I'm not very experienced working with house wiring, and I don't want to spend too much money, but I would like to build some kind of easy way to find the light switch. The idea would be to make something large enough to find in the dark.

G.Z., Norwood, MA

You'll like this circuit because there's no connection to your house wiring, and it's very inexpensive to build. The circuit is based on the electrical fields produced by the ac house wiring. When you touch the plate, which

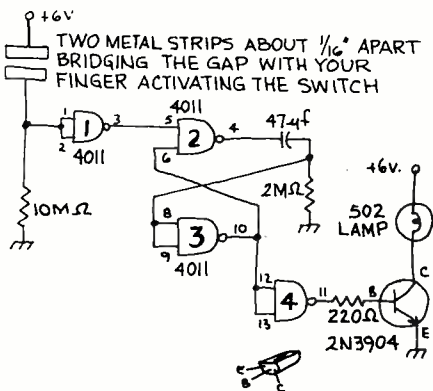

can be any size and decorated in any manner, the light will go on, and remain on for several minutes, more than enough time to get across the living room floor without stepping on something. And at \$5, you can put one of these wonders in every room.

Big Brother is watching

My tv game puts out a signal that needs to be hooked inside the tv set. Wouldn't it be a lot easier to attach it to the antenna screws on the back of the set?

J.L., Santa Fe, NM

Yes it would, but it would also be a lot easier to get yourself into a lot of hot water with the FCC. That's because your tv antenna works equally well at transmitting to signals as it does receiving them, and your tv game is really nothing more than a low-power transmitter. So, if you connect it to the tv terminals, you end up broadcasting your game for the entire neighborhood to see. You can solve your problem, though, by using an FCC certified coupler.

Single-channel nut

A stereo store tells me I'm nuts for wanting to use only one speaker, but my room is so small I can't hear the stereo effect from two speakers anyway. I don't need big volume. How do I hook up one good speaker to the left and right channel outputs on my stereo receiver, at the same time?

P.B., Annapolis, MD

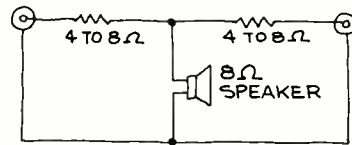

The solution to your problem depends on the circuit in your receiver. If the circuit permits, you can simply plug the speaker into either output jack, set the amp for mono, and adjust the balance control so that no output appears at the unused jack. If you must have a load connected to both outputs, this simple hookup will work nicely. Make sure the resistors can handle the power. Their wattage rating should be at least as great as that of your receiver.

One, two, three . . .

I'd like a seven-segment LED to count 0-9 over and over. How few parts can I get by with?

E.D., Columbus, OH

How about two? That's right, all you'll need is a 4026 chip and a small (.1 to .3 inch) seven segment display. Larger displays will require transistor drivers. You didn't state what it was that you wanted to count. If you're counting pulses from some other cir-

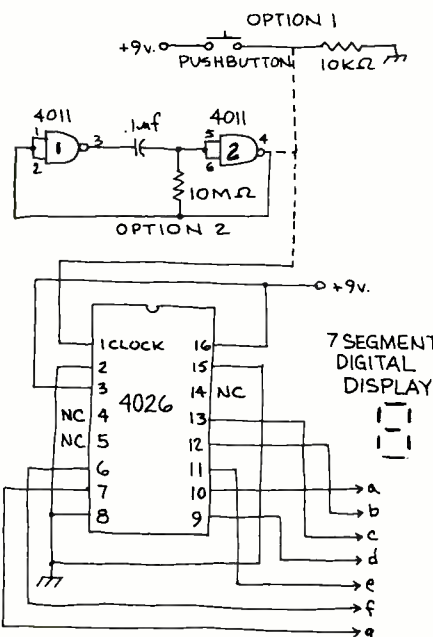

cuit, just feed them into the clock input (pin 1) and you're in business. If you want to manually advance the clock, use option 1. You'll have to use a mercury switch to prevent false counts due to contact bounce. If you want a free-running display, use option 2. The rate at which the count advances is determined by the RC time constant. The values shown give you a 1 Hz advance rate.

Pink-ticket beater

The FCC requires hams to give their calls every 10 minutes during a QSO. What's the cheapest reminder signal I can build?

N.B., Chicago, IL

This simple timer will keep you legal. The heart of the circuit is a free-running flip-flop. Depending on the values you choose, it will trigger an audio oscillator to run for one sec-

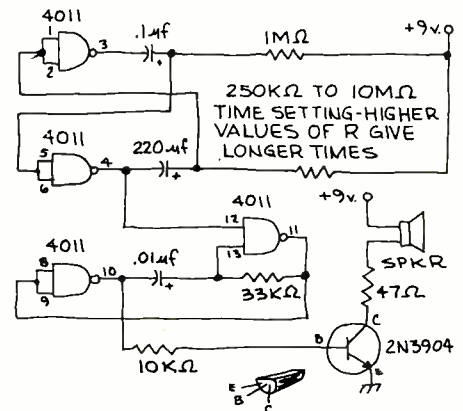

ond every so often. To get exactly 10 minutes, you'll need a 2.72 meg resistor. The best way to get this is to connect a 1 megohm potentiometer in series with a 2.2 meg resistor. Get an approximate setting with an ohmmeter, then fine tune with a clock to get your 10 minute interval.

Stumps the editors

There's this old tube radio in the kitchen whose only problem is an occasional hiss which almost drowns out the station I'm listening to. I think this is some sort of intermittent problem inside the set but it beats the hell out of me how the hissing always stops when someone runs water out of a faucet. Can you guys at ME end hours of head scratching with a reasonable explanation?

K.J., Marietta, Ohio

It beats the hell out of us too, K.J.

Jeff is an electronics artist whose brush is a soldering iron, whose canvas is a breadboard and whose palette holds resistors, transistors, capacitors and integrated circuits. Complete projects designed by Jeff will be regular features in Modern Electronics. The Clinic letters in this first issue were selected from inquiries directed to editors of other Cowan Publishing Corp. magazines.

BY JUDY CURTIS, WB3AIQ

Take a peek inside your ham and CB radios. You may find a microcomputer thinking away inside.

Quack, Squawk. Your single-sideband receiver is tuned off frequency and Fred's signal sounds like Donald Duck talking. Twisting the clarifier knob a bit, you fine-tune the rig and Fred's voice becomes clear.

You listen to Fred's transmission and then start your own when he turns it over to you. Across town, he is leaning back in an easy chair, sipping a Coke. Even though your transmitter is putting out its signal on a slightly different frequency from where he had his receiver tuned, he doesn't have to do any fine tuning! An honest-to-god microcomputer, *inside* Fred's radio, is tweaking the fine tuning for him.

Tiny Computer Brain

It's not imagination. The Texas Instruments 40-channel single-sideband (SSB) citizens-band radio has not one but *two* tiny computers built in: one in the radio and one in the microphone.

The microcomputers do many different jobs at the same time in the TI CB. The receiver tuning works by locking on to a brief burst of information transmitted by a TI rig to which you are listening. When you transmit, your TI radio sends an information burst so the receiving station can lock onto your signal and automatically clarify it.

The microcomputers, each made of slices of silicon only one-twentieth of a square inch, are revolutionary in SSB radios. They will allow hands-free CB operation. They do, for the first time, present a workable method, tested on the air, of locking a ham or CB or any other receiver onto an incoming SSB signal. They set the stage for SSB repeaters on the two-meter ham band and elsewhere in the radio spectrum.

TI's brains are the same technology which helped Mariner II navigate to Mars and which flies jet fighters at supersonic speeds at treetop level.

Better than FM

Ham repeaters now eat huge chunks out of the VHF and UHF bands because they use the frequency-modulation (FM) means of carrying voices. If machines repeated SSB, rather than FM, three or four times as many repeaters could occupy the same bands.

FM signals are broad. Receivers, poorly tuned as far from the center of a channel as 1.5 kHz, can let you hear what is being said. SSB, on the other hand, requires precise tuning by the repeater of signals it hears and precise tuning by your receiver of signals arriving from the repeater. Old-fashioned

transceiver, could make SSB repeaters possible right now!

Computers already are in use by hams, by the way. At Wheeling, W. Va., amateur radio operators control their machine through a microcomputer built right into the repeater. Other hams are plugging tiny computer chips into



Two! That's right, two microcomputers smaller than the tip of her fingers talk to each other in the Texas Instruments CB. One is in the microphone; one in the radio. They keep a constant housekeeping watch on the inner workings of the set plus do such extra chores as fine tune the receiver for off-channel signals.

analog circuits are just too touchy to do the job day-after-day, tucked away on a cold mountaintop away from human operators. (See *How Ham Repeaters Work* in this issue for details.)

Microprocessor-controlled SSB, as in TI's rig, coupled with accurate frequency selection and control as in the ICOM IC-245 two-meter ham SSB/FM

their repeaters to turn the devices on and off by remote control, handle autopatch telephone-call dialing and a score of other complex chores. 

Judy, an avid CW and two-meter ham operator, uses marine radio on her sloop and CB to beat the Interstate bears.

NEW

Frequency Counter

\$79⁹⁵ kit

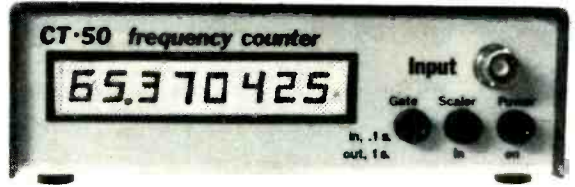

UTILIZES NEW MOS-LSI CIRCUITRY

You've requested it, and now it's here! The CT-50 frequency counter kit has more features than counters selling for twice the price. Measuring frequency is now as easy as pushing a button, the CT-50 will automatically place the decimal point in all modes, giving you quick, reliable readings. Want to use the CT-50 mobile? No problem, it runs equally as well on 12 V dc as it does on 110 V ac. Want super accuracy? The CT-50 uses the popular TV color burst freq. of 3.579545 MHz for time base. Tap off a color TV with our adapter and get ultra accuracy — .001 ppm! The CT-50 offers professional quality at the unheard of price of \$79.95. Order yours today!

CT-50, 60 MHz counter kit \$79.95
 CT-50 WT, 60 MHz counter, wired and tested 159.95
 CT-600, 600 MHz prescaler option for CT-50, add 29.95

SPECIFICATIONS

Sensitivity: less than 25 mv.
 Frequency range: 5 Hz to 60 MHz, typically 65 MHz
 Gatetime: 1 second, 1/10 second, with automatic decimal point positioning on both direct and prescale
 Display: 8 digit red LED .4" height
 Accuracy: 10 ppm, .001 ppm with TV time base!
 Input: BNC, 1 megohm direct, 50 Ohm with prescale option
 Power: 110 V ac 5 Watts or 12 V dc @ 1 Amp
 Size: Approx. 6" x 4" x 2", high quality aluminum case

Color burst adapter for .001 ppm accuracy

CB-1, kit \$14.95



CLOCK KIT 6 digit 12/24 hour

Want a clock that looks good enough for your living room? Forget the competitor's kludges and try one of ours! Features: jumbo .4" digits, Polaroid lens filter, extruded aluminum case available in 5 colors, quality PC boards and super instructions. All parts are included, no extras to buy. Fully guaranteed. One to two hour assembly time. Colors: silver, gold, black, bronze, blue (specify).
 Clock kit, DC-5 \$22.95
 Alarm clock, DC-8, 12 hr only 24.95
 Mobile clock, DC-7 25.95
 Clock kit with 10 min ID timer, DC-10 25.95
 Assembled and tested clocks available, add \$10.00

CHEAP CLOCK KIT \$8.95

DC-4 Features:
 ● 6 digit .4" LED
 ● 12 or 24 format

Does not include board or transformer

PC Board \$2.95
 Transformer \$1.49

VIDEO TERMINAL KIT \$149.95

A compact 5 x 10-inch PC card that requires only an ASCII keyboard and a TV set to become a complete interactive terminal for connection to your microprocessor synchronous interface. Its many features are single 5 volt supply, crystal controlled sync and baud rates (up to 9600 baud), 2 pages of 32 characters by 16 lines, read to and from memory, computer and keyboard operated cursor and page control, parity error display and control, power-on initialization, full 64-character ASCII display, block-type search-thru cursor. Keyboard/computer control backspaces, forward spaces, line feeds, rev. line feeds, home, returns cursor. Also clears page, clears to end of line, selects page 1 or 2, reads from or to memory. The card requires 5 volts at approx. 900 ma and outputs standard 75 ohm composite video.

TH3216 Kit \$149.95
 TH3216, Assembled and Tested 239.95
 VD-1, Video to RF Modulator Kit 6.95

CAR CLOCK KIT \$27.95



12/24 Hour 12 Volt AC or DC
 ● High Accuracy (1 minute/month)
 ● 6 jumbo .4" LED readouts
 ● Easy, no polarity hookup
 ● Display blanks with ignition
 ● Case, mounting bracket included
 ● Super instructions
 Complete Kit, DC-11 \$27.95

AUTO-DIMMER \$2.50

Automatically adjusts display brightness according to ambient light level. For DC-11 Car Clock.

MINI-KITS

STONE DECODER KIT

A complete tone decoder on a single PC Board. Features: 400-5000 Hz adjustable frequency range, voltage regulation, 567 IC. Useful for touch-tone decoding, tone burst detection, FSK demod, signaling, and many other uses. Use 7 for 12 button touch-tone decoding. Runs on 5 to 12 volts.
 Complete Kit, TD-1 \$4.95



SUPER-SNOOP AMPLIFIER

A super-sensitive amplifier which will pick up a pin drop at 15 feet! Great for monitoring baby's room or as a general purpose test amplifier. Full 2 watts of output, runs on 6 to 12 volts, uses any type of mike. Requires 8-45 ohm speaker.
 Complete Kit, BN-9 \$4.95

FM WIRELESS MIKE KIT

Transmit up to 300' to any FM broadcast radio, uses any type of mike. Runs on 3 to 9 V. Type FM-2 has added super sensitive mike preamp.
 FM-1 \$2.95 FM-2 \$4.95

COLOR ORGAN/MUSIC LIGHTS

See music come alive! 3 different lights flicker with music or voice. One light for lows, one for the mid-range and one for the highs. Each channel individually adjustable, and drives up to 300 watts. Great for parties, band music, nite clubs and more.
 Complete Kit, ML-1 \$7.95

LED BLINKY KIT

A great attention getter which alternately flashes 2 Jumbo LEDs. Use for name badges, buttons, or warning type panel lights. Runs on 3 to 9 volts.
 Complete Kit \$2.95

POWER SUPPLY KIT

Complete triple regulated power supply provides variable 315 volts at 200 mA and +5 volts at 1 Amp. 50 mV load regulation good filtering and small size. Kit less transformers. Requires 6-8 V at 1 Amp and 18 to 30 VCT.
 Complete Kit, PS-3LT \$6.95



SIREN KIT

Produces upward and downward wail characteristic of police siren. 5 watts audio output, runs on 3-9 volts, uses 8-45 ohm speaker.
 Complete Kit, SM-3 \$2.95

DECADE COUNTER PARTS

Includes: 7490A, 7475, 7447, LED readout, current limit resistors, and instructions on an easy to build low cost frequency counter.
 Kit of parts, DCU-1 \$3.50

600 MHz PRESCALER



Extend the range of your counter to 600 MHz. Works with all counters. Less than 150 mv sensitivity. Specify 10 or 100. Wired, tested, PS-1B \$59.95
 Kit, PS-1B \$44.95

30 watt 2 meter Power Amp

The famous RE class C power amp now available mail order! Four Watts in for 30 Watts out, 2 in for 15 out, 1 in for 8 out, incredible value, complete with all parts, instructions and details on T-R relay. Case not included.
 Complete Kit, PA-1 \$22.95

CALENDAR ALARM CLOCK

Has every feature one could ever ask for. Kit includes everything except case, build it into wall, station or even car!

FEATURES:
 ● 6 Digits, .5" High LED ● 12/24 Hour Format
 ● Calendar shows mo./day ● Snooze button
 ● True 24 Hour Alarm ● 7001 chip does all!
 ● Battery back up with built-in on chip time base
 Complete Kit, less case, DC-9 \$34.95

LINEAR		REGULATOR		TRANSISTORS	
5314 Clock	\$2.95	555	\$.50	78MG	\$1.49
74S00	.35	556	.75	309K	.89
74S112	.75	566	1.49	309H	.99
7447	.79	567	1.49	340K-12	.99
7473	.35	1458	.50	7805	.89
7475	.50	LED DRIVER	7812	7812	.89
7490A	.55	75491	.50	7815	.89
74143	3.50	75492	.50	7818	.89

DIODES: 1KV, 2.5A 5/\$1.00 100V, 1A 10/\$1.00 1N914A type 50/\$2.00

LED DISPLAYS

FND 35975
 FND 510 1.25
 DL 707 1.25
 HP 7730 1.25
 Red Polaroid Filter 4.25" X 1.125"59

741 OP-AMP SPECIAL

Factory prime mini dip with both Xerox and 741 part numbers
 10 for \$2.00

SOCKETS

14 PIN 5/\$1.00
 16 PIN 5/\$1.00
 24 PIN 2/\$1.00
 40 PIN 3/\$2.00

FERRITE BEADS

with info and specs 15/\$1.00
 6 hole Balun Beads 5/\$1.00

ramsey electronics

TELEPHONE ORDERS WELCOME

Satisfaction guaranteed or money refunded. C.O.D. add \$1.00. Orders under \$10.00 add \$.75. NY residents add 7% tax.



P.O. Box 4072 M, Rochester, NY 14610

(716) 271-6487

BY HANS FANTEL

Your stereo will sound better with a built-in microcomputer tweaking the circuits and peaking the response.

If I were to take bets on the future of audio, I would give heavy odds that before long, digital computer techniques will radically change our methods of sound recording. In fact, the first steps in this development have already been accomplished.

Up to now, sound reproduction worked entirely on the analog principle. The recorded signals were direct images

opened the way to digital audio. For example, one of the first digital audio recorders, recently shown by Sony, uses the Betamax video cassette machine as its basic recording unit. With an added analog-to-digital converter, the audio signal is translated into pulse form and then imprinted on the tape by the Betamax. The process is reversed in playback. Known as Pulse Code Modulation

I was greatly impressed by the clarity and exceptional dramatic impact of the music at high volume levels. This is partly due to the fact that the rise-time characteristic of pulse amplifiers is superior to that of conventional audio (analog) amplifiers. Consequently, it reproduces transients and sudden loudness peaks (such as a drumbeat, cymbal crash, or a sudden loud chord on the piano) with virtually no distortion due to "overhoot" and "ringing." This fact was impressively confirmed by watching square-wave tests on an oscilloscope screen. Sony's new digital sound gear is still being refined at their laboratories in Tokyo, but the company hopes to have the PCM unit ready for sale during 1978 at about \$1300. My guess is that it will be—initially at least—used mostly in recording studios rather than in the home.

Now that audio signals are being digitalized, new possibilities are also opening up in terms of recording media. The phonograph record with its mechanical scanner—the stylus or "needle"—represents a rather primitive technology that hasn't basically changed in the hundred years since Edison patched together his first "talking machine." This is now due for a change. The latest form of disc recording—used by Philips in their new videodisc soon to be marketed in this country by Magnavox—employs a laser beam to inscribe and "read out" information from the record groove. Originally tailored to the demands of video, this laser-based disc-recording system has a 4 MHz bandwidth. This easily accommodates the 200,000 Hz bandwidth required for digital audio recording. Once videodisc players are standard items in the American home (something likely to happen within the next five years), they could be easily adapted for use as digital phonographs. The extra bandwidth could then be used for multichannel presentation of musical material. Moreover, on such discs the laser track is imbedded beneath a plastic shield, making the records immune to wear and careless handling.

Having seen and heard the Philips—
please turn to page 22

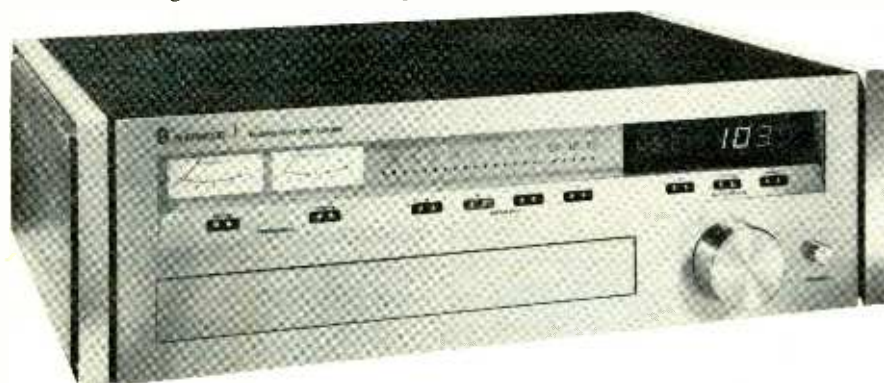

Sherwood Micro-CPU 100 digital stereo tuner has a microcomputer built in. It memorizes the call letters of your favorite radio stations. When you tune in one of those stations, the letters are displayed in light-emitting diodes (LEDs).

of the actual musical waveforms. Like most analog techniques, this process is troubled by distortion and noise. In a way, the whole history of the high-fidelity movement is a continuing effort to reduce these drawbacks. But now audio engineers are thinking of a different approach. Instead of trying to reduce the problems of noise and distortion, they are planning to undercut these problems at their root by abandoning the analog principle and going digital. One prominent audio designer with whom I talked at the last meeting of the Audio Engineering Society puts it this way:

"A generation ago, the computer industry recognized the advantage of digital over analog techniques. The development of miniaturized, high-speed solid-state circuits in recent years now enables the audio industry to follow the same path."

It is the development of video recording techniques with their enormous bandwidth—up to 4 MHz—that

(PCM for short) the process opens the way to duplication of tapes without any increase in noise and distortion. Once the audio signal is encoded in digital pulses, it can be processed further without suffering any quality loss at all. The pulses, which spell out the waveform, are either there or not there, leaving no room for any error in transmission or amplification and thus making added noise and distortion theoretically impossible.

Pulse code modulation

A companion item in Sony's new line of digital sound equipment is a PCM amplifier rated at 180 watts RMS per channel. Since it amplifies intermittent pulses rather than a continuous signal, it can generate its powerful output without having to be particularly large or heavy. Unlike conventional amplifiers, it runs very cool and does not require massive heat sinks that add bulk and weight.

At a recent demonstration of this unit,

mobile

continued from page 8

the high frequency (HF) portion using double sideband am signals instead of fm signals used at VHF frequencies. VHF signals are transmitted line of sight and are better for short range communications. HF signals skip around the globe, bouncing from the ionosphere to Earth, back to the ionosphere, back to Earth and so on around the world. These signals are better for long range communications, and ships crossing the seas still use HF frequencies. Double sideband signals have been abandoned, however, in favor of more efficient, more readable single sideband (SSB) signals.

The portion of the VHF band below boaters at 144-148 MHz is used by amateur radio operators or hams. Many hams are die-hard mobile operators. In early radio years when equipment weighed tons and needed constant tuning adjustments, hams stubbornly carted stations into the car so they could operate mobile.

Now with tiny battery-powered handheld transceivers, every ham can carry a radio on his belt. Mobile hams with low power one-watt hand helds can talk up to 100 miles away via amateur radio repeaters. A repeater, in the 146-148 MHz portion of the ham bands, hears a weak signal in its super-sensitive receiver and retransmits it long distance over its high power transmitter.

A California ham had strapped on his handheld radio before driving his jeep up in the California mountains. The February day was clear and crisp, although cold on the way up. But as he started down, an icy snow storm broke. His jeep plummeted over a cliff. Slightly injured, the man was able to call for help via a repeater. Rescue teams were hampered by the storm and the jeep's location could be pin-pointed only by following the tiny radio's signal. In the freezing cold, unable to talk anymore, the ham managed to click the dots and dashes of the International Morse code, giving the searchers a signal to follow.

With complete HF stations being refined down to the size of a shoe box, mobile hams can talk around the world while cruising along the highway. Some mobile hams work distant stations across the globe via one of two Orbital Satellites Carrying Amateur Radio (OSCAR). One Pennsylvania ham's ultimate goal is to work OSCAR while aeronautical mobile.

No more marveling at the policeman's tiny handheld radios. Or being amazed at space communications. The technology is available for everyone to use. In the future, we may all have our own pocket telephone to carry around with us wherever we go. We'll be linked into a mobile network with global possibilities. 

stereo

continued from page 20

Magnavox videodisc, I can assure you that it really works, and I am excited about the audio possibilities of the new format, which would eliminate all the current drawbacks of phonograph records. Magnavox says they'll price the first videodisc players at \$500. Granted, that's a bit stiff, but really no more expensive than a top-rank, direct-drive, quartz-controlled standard turntable costs now.

Not all digital audio equipment is somewhere off in the future. Some of it you can take off the shelf right now—for example, radio tuners for stereo systems with digital display of the frequency to which they are tuned. Virtually all these digital designs derive their local oscillator frequency from a crystal, giving them excellent tuning stability. By far the fanciest of these digital tuners is Sherwood's Micro-CPU 100, which also contains a memory into which you can enter the call letters of your favorite stations. Whenever you



Sony pulse-code modulation box takes audio, which is an analog signal, and changes it to a digital signal for better storing on tape. It reconverts, digital-to-analog, upon playback.

tune to the frequencies of those stations, their call letters light up in LEDs. It's one nice frill among the many remarkable features of this highly advanced design, which incorporates automated functions that adjust circuit parameters (IF bandwidth, stereo separation, etc.) to the quality of the incoming signal. These automated internal functions are also governed by built-in logic devices. Just how many listeners will ante up the asking price of \$2000 for this truly exceptional tuner remains to be seen.

As digital audio equipment becomes more common, prices will surely respond to competitive pressure, but it is doubtful that they will soon go down to the level of ordinary sound gear. What seems certain at this point is that the seemingly separate technologies of data processing and audio are rapidly merging and that audio has much to gain by it. 

Hans is stereo editor of The New York Times and Esquire magazine.

computers

continued from page 12

that they control the operation and timing of the device to a large degree; in some cases they may even take over temporary control of the computer and its memory during input or output operations.

The differences between large and small computers are in how these parts of the computer system are arranged and housed. In large-scale computers the CPU may be a large cabinet with the memory either in the same cabinet or in other cabinets, depending on memory size. These large computers commonly have a memory capable of storing from 64 thousand to perhaps a million or more numbers. In computer terminology, a K is 1024 rather than 1000 as in common electronics. A 64K memory would be small by commercial standards; 256K would be more common. Input devices and their interfaces or controllers would also tend to occupy their own cabinets.

Small computers, on the other hand, are often contained in desk cabinets or are even smaller. In *minicomputers*, the CPU, memory, and most of the interfaces could be contained in a desk-top cabinet. A similar cabinet is used for many *microcomputers* such as the Altair, IMSAI, or SWTP systems used by hobbyists. The difference is that in a minicomputer the CPU may consist of several hundred integrated circuits and several printed circuit boards, whereas in a microcomputer the CPU might be at most a few dozen integrated circuits on one board; in fact, most of the circuitry might be on just one IC called a microprocessor unit or *MPU*. Mini and microcomputers also tend to have less memory, in some cases as little as just a few thousand locations.

Some of the early MPU integrated circuits required several dozen other integrated circuits as well as external memory to operate, but newer MPU's sometimes contain built-in memory and interfacing circuits, with the result that they can operate alone or with just one or two other integrated circuits. This is perhaps the most intriguing concept to come along, since it means that computers are at last leaving the field of pure computing. For example, Texas Instruments has introduced a new Citizen's Band transceiver with all its controls mounted on the microphone. To avoid the need for over twenty wires in the mic cable, the microphone has a built-in microprocessor and the main unit has a second. The two microprocessors communicate over just four wires. This is just one example of how microprocessors do unconventional jobs in non-computing computers. 

Pete, a university professor, is the leading computer writer on the East Coast.

Vhf engineering

PRICES EFFECTIVE
JAN. 15, 1977

THE WORLD'S MOST COMPLETE LINE OF VHF-FM KITS AND EQUIPMENT

RX28C	28-35 MHz FM receiver with 2 pole 10.7 MHz crystal filter	\$ 64.95
RX28C W/T	same as above—wired & tested	117.95
RX50C Kit	30-60 MHz rcvr w/2 pole 10.7 MHz crystal filter	64.95
RX50C W/T	same as above—wired & tested	117.95
RX144C Kit	140-170 MHz rcvr w/2 pole 10.7 MHz crystal filter	74.95
RX114C W/T	same as above—wired & tested	119.95
RX220C Kit	210-240 MHz rcvr w/2 pole 10.7 MHz crystal filter	74.95
RX220C W/T	same as above—wired & tested	117.95
RX432C Kit	432 MHz rcvr w/2 pole 10.7 MHz crystal filter	84.95
RX432C W/T	same as above—wired & tested	129.95

RECEIVERS



RXCFL	accessory filter for above receiver kits gives 70 dB adjacent channel rejection	8.95
RF28 Kit	10 mtr RF front end 10.7 MHz out	13.50
RF50 Kit	6 mtr RF front end 10.7 MHz out	13.50
RF144D Kit	2 mtr RF front end 10.7 MHz out	18.50
RF220D Kit	220 MHz RF front end 10.7 MHz out	18.50
RF432 Kit	432 MHz RF front end 10.7 MHz out	29.50
IF 10.7F Kit	10.7 MHz IF module includes 2 pole crystal filter	29.50
FM455 Kit	455 KHz IF stage plus FM detector	18.50
AS2 Kit	audio and squelch board	16.00

TX50	transmitter exciter, 1 watt, 6 mtr	44.95
TX50 W/T	same as above—wired & tested	64.95
TX144B Kit	transmitter exciter—1 watt—2 mtrs	34.95
TX144B W/T	same as above—wired & tested	59.95
TX220B Kit	transmitter exciter—1 watt—220 MHz	34.95

TRANSMITTERS



TX220B W/T	same as above—wired & tested	59.95
TX432B Kit	transmitter exciter 432 MHz	49.95
TX432B W/T	same as above—wired & tested	79.95
TX150 Kit	300 milliwatt, 2 mtr transmitter	24.95
TX150 W/T	same as above—wired & tested	39.95

PA2501H Kit	2 mtr power amp—kit 1w in—25w out with solid state switching, case, connectors	64.95
PA4010H Kit	2 mtr power amp—10w in—40w out—relay switching	64.95
PA50/25 Kit	6 mtr power amp, 1w in, 25w out, less case, connectors & switching	54.95
PA144/15 Kit	2 mtr power amp—1w in—15w out—less case, connectors and switching	44.95
PA144/25 Kit	same as PA144/15 kit but 25w	54.95
PA220/15 Kit	similar to PA144/15 for 220 MHz	44.95
PA432/10 Kit	power amp—similar to PA144/15 except 10w and 432 MHz	54.95
PA140/10 W/T	10w in—140w out—2 mtr amp	219.95
PA140/30 W/T	30w in—140w out—2 mtr amp	189.95

POWER AMPLIFIERS

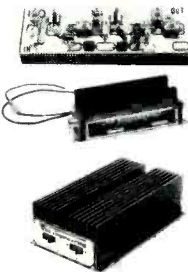

Blue Line	RF power amp, wired & tested, emission—CW-FM-SSB/AM	Power Input	Power Output	
Model	BAND			
BLC 10/70	144 MHz	10W	70W	149.95
BLC 2/70	144 MHz	2W	70W	164.95
BLC 10/150	144 MHz	10W	150W	254.95
BLC 30/150	144 MHz	30W	150W	239.95
BLD 2/60	220 MHz	2W	60W	164.95
BLD 10/60	220 MHz	10W	60W	154.95
BLD 10/120	220 MHz	10W	120W	259.95
BLE 10/40	420 MHz	10W	40W	179.95
BLE 2/40	420 MHz	2W	40W	179.95
BLE 30/80	420 MHz	30W	80W	259.95
BLE 10/80	420 MHz	10W	80W	289.95

PS15C Kit	15 amp—12 volt regulated power supply w/case, w/fold-back current limiting and overvoltage protection	94.95
PS15C W/T	same as above—wired & tested	124.95
PS25M Kit	25 amp—12 volt regulated power supply w/case, w/fold-back current limiting and ov, with meter	154.95
PS 25M W/T	same as above—wired & tested	179.95

POWER SUPPLIES



O.V.P.	adds over voltage protection to your power supplies, 15 VDC max	12.95
PS3A Kit	12 volt—power supply regulator card with fold-back current limiting	10.95
PS3012 W/T	new commercial duty 30 amp 12 VDC regulated power supply w/case, w/fold-back current limiting and overvoltage protection	249.95

RPT50 Kit	repeater—6 meter	499.95
RPT50	repeater—6 meter, wired & tested	799.95
RPT144 Kit	repeater—2 mtr—15w—complete (less crystals)	499.95
RPT220 Kit	repeater—220 MHz—15w—complete (less crystals)	499.95
RPT432 Kit	repeater—10 watt—432 MHz (less crystals)	579.95
RPT144 W/T	repeater—15 watt—2 mtr	799.95
RPT220 W/T	repeater—15 watt—220 MHz	799.95
RPT432 W/T	repeater—10 watt—432 MHz	849.95

REPEATERS



DPLA50	6 mtr close spaced duplexer	575.95
DPLA144	2 mtr, 600 KHz spaced duplexer, wired and tuned to frequency	379.95
DPLA220	220 MHz duplexer, wired and tuned to frequency	379.95
DPLA432	rack mount duplexer	319.95
DSC-U	double shielded duplexer cables with PL259 connectors (pr.)	25.00
DSC-N	same as above with type N connectors (pr.)	25.00

TRX50 Kit	Complete 6 mtr FM transceiver kit, 20w out, 10 channel scan with case (less mike and crystals)	244.95
TRX144 Kit	same as above, but 2 mtr & 15w out	234.95
TRX220 Kit	same as above except for 220 MHz	234.95
TRX432 Kit	same as above except 10 watt and 432MHz	254.95
TRC-1	transceiver case only	239.95
TRC-2	transceiver case and accessories	49.95

TRANSCEIVERS



OTHER PRODUCTS BY VHF ENGINEERING

CD1 Kit	10 channel receive xtal deck w/diode switching	\$ 7.95
CD2 Kit	10 channel xmit deck w/switch and trimmers	15.50
CD3 Kit	UHF version of CD1 deck, needed for 432 multi-channel operation	13.50
COR2 Kit	carrier operated relay	22.75
SC3 Kit	10 channel auto-scan adapter for RX with priority	19.95
Crystals	we stock most repeater and simplex pairs from 146.0-147.0 (each)	5.00
CWID Kit	159 bit, field programmable, code identifier with built-in squelch tail and ID timers	39.95
CWID	wired and tested, not programmed	54.95
CWID	wired and tested, programmed	59.95
MIC1	2,000 ohm dynamic mike with P.T.T. and coil cord	12.95
TS1 W/T	tone squelch decoder	59.95
TS1 W/T	installed in repeater, including interface accessories	89.95
TD3 Kit	2 tone decoder	35.95
TD3 W/T	same as above—wired & tested	59.95
HL144 W/T	4 pole helical resonator, wired & tested, swept tuned to 144 MHz ban	29.95
HL220 W/T	same as above tuned to 220 MHz ban	29.95
HL432 W/T	same as above tuned to 432 MHz ban	29.95

SYN II Kit	2 mtr synthesizer, transmit offsets programmable from 100 KHz—10MHz, (Mars offsets with optional adapters)	169.95
SYN II W/T	same as above—wired & tested	239.95
SYN 220 Kit	same as SYN II Kit except 220-225 MHz	169.95
SYN 220 W/T	same as above—wired & tested	239.95

SYNTHESIZERS



Vhf engineering

DIVISION OF BROWNIAN ELECTRONICS CORP.

BOX S / 320 WATER ST. / BINGHAMTON, N.Y. 13901 / Phone 607-723-9574

Prices and specifications subject to change without notice. Export prices slightly higher. 502 3100-1.78



CIRCLE 23 ON READER SERVICE CARD

TIMESHARING

The 80-103A works both ways. Your system can call a timesharing service and communicate as an intelligent terminal *OR* your S-100 system can be the timesharing system where the 80-103A answers the phone and communicates with terminals or other processors.

80-103A DATA COMMUNICATIONS ADAPTER

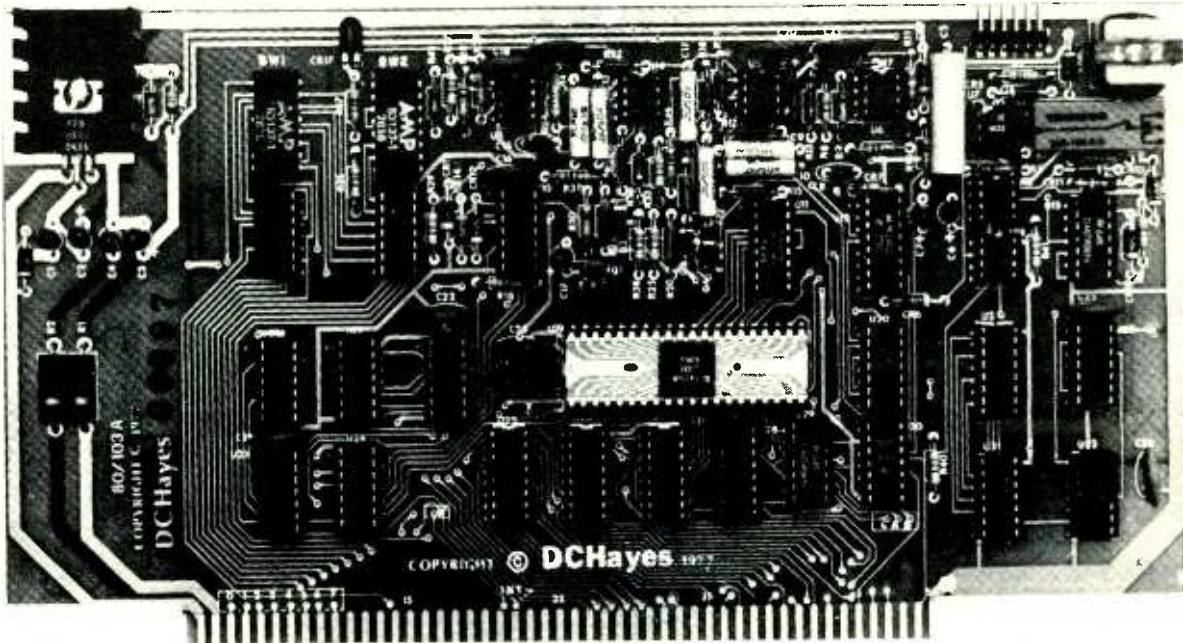

The 80-103A DATA COMMUNICATIONS ADAPTER was developed to function as an S-100 bus compatible serial interface incorporating a fully programmable modem and Telco interface. These functions are usually accomplished by the use of two separate modules: 1) a serial I/O board, and 2) an external modem. By combining these features on a single board, the 80-103A can offer microcomputer applications significant cost/performance advantages over other implementations.

- FULLY PROGRAMMABLE FEATURES
- AUTOMATED DIALING AND ANSWER
- ORIGINATE OR ANSWER MODE
- 110-300 BIT/SEC DATA RATES
- CHARACTER FORMAT AND PARITY
- ERROR DETECTION
- FULLY BUFFERED, OUTPUTS DRIVE 25 S-100 BUS LOADS

DC Hayes Associates offers a full range of capabilities for solving your information handling problems. Whether your problem is large or small, we will apply innovative techniques for finding the best solution. Contact us about our products and services.

- STANDARD U.S. FREQUENCIES
- FULL TELCO COMPATIBILITY WHEN ATTACHED TO DAA
- COMPATIBLE WITH EXISTING TELE-TYPES AND TIME SHARING MODEMS
- ALL DIGITAL MODULATION AND DEMODULATION. NO ADJUSTMENTS REQUIRED.

PRICES:

Assembled 80-103A with 48 hour burn in and 90 day warranty is \$279.95

Bare Board with manual is \$49.95

DC Hayes associates

P.O. Box 9884 • Atlanta, Georgia 30319 • (404) 231-0574

THE COMPUTER REVOLUTION

1978 is the year of the home computer.
Personal computers are on store shelves across the country.
Here's what you'll need to know to get started.

by Anthony R. Curtis,
Modern Electronics Editor

A new era has dawned. Computers, which revolutionized our lives years ago, are in a state of revolution themselves. They now are so small, so easily built, so simple to operate that everyone can have one in his home to do practically all his chores.

It boggles the mind to dream up all the things computers can do. Uses seem endless because computers remember

things. They store and file all sorts of information we might lose, like:

- Your family budget, financial records, anything relating to income taxes. Put data in every week or month and when April comes, instead of weeks of headaches, press the right buttons and the information will spill out onto your 1040, ready to be mailed in.
- Games and courses. The machine will teach your kids the Three R's while you

eat dinner. Or you can take a brush-up course yourself. Later, play Blackjack or Chess while Junior makes Lunar Landings.

■ Family medical data. Your computer will remember when your kid had what disease, dental checkups, even vet calls for the cat.

■ When you're home. Let the computer turn on lights when you enter a room,



Complete home
computer system by
The Digital Group, Box
6528, Denver, Colo.
80206.

Radio Shack
TRS-80 home
computer system



COMPUTER REVOLUTION

turn them off when you leave, and switch them randomly if you are away.

■ **Recipes.** When guests show unexpectedly for dinner, it will convert proportions of ingredients and cook the right amount for 10. And it'll count calories, protein content and vitamins to give you a weekly readout on intake. Store complete family nutrition records in its memory.

■ **Gardening needs.** Let it control yard sprinklers and mind the rose spray.

■ **Anniversaries.** Each morning, take a computer list of birthdays, vacations or when Sissy is coming home from college from the machine's memory.



CCSMAC VIP, above is a low-cost hobby computer kit by RCA, Solid State Division, Route 202, Somerville, N.J. 08876.



H8 computer, from Heath Co., Benton Harbor, Mich. 49022, is the heart of a complete Heathkit system.

SR60A personal computer by Texas Instruments, Box 5012, Dallas, Tex. 75222, can write, on a letter-quality typewriter, full-page reports. It will keep the family budget, health and nutrition records, and even solve the most advanced college math homework problems. It is as simple to operate as a calculator.

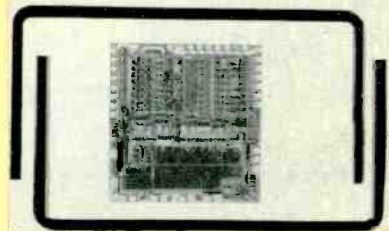

Framed by two ordinary staples, above, a tiny Bell Telephone Labs microprocessor contains 7,000 transistors. As Bell was inventing the transistor 30 years ago, computers were being conceived around vacuum tubes.



Altair 8800b, left, from MITS, 2450 Alamo S.E., Albuquerque, New Mexico 37106, is the latest version of the microprocessor which started the home computer revolution. It has been the standard of the industry.



Altair 680b, left, by MITS, is smaller than the 8800b but popular because it does most of what the 8800 will do. Circuit board, below, plugs into 680 to give it a very large 16K memory.

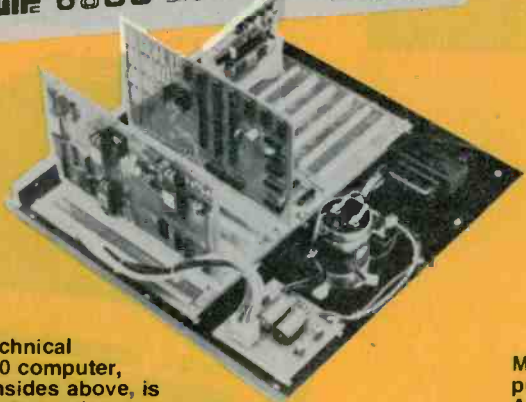

Southwest Technical Product's 6800 computer, outside and inside above, is built around a Motorola microprocessor integrated circuit chip. Teletype, video display and other input/output devices can be used to communicate with this SWTPC machine.



Model 500-1, above, from Ohio Scientific, Hiram, Ohio 44234, is a computer with Basic language built inside, in its memory, ready to run. Add video display and you're in business.

Tubes were large, hot and heavy. An early-50s computer filled a room but did little more than a \$15 hand calculator today. Transistors changed all that, being small, light weight and cool. Solid-state computers filled rooms but solved marvelously-complex problems. Integrated circuits were packages of dozens and hundreds of transistors, bringing mini-computers. Mini machines did, in the 60s in closet-size boxes, what the older full-size computers had done. Large-scale integration, scrunching thousands of transistors into tiny integrated circuit 'chips,' gave us microprocessors as the brains of microcomputers in the 70s.



You command the POLY 88 microcomputer via the standard typewriter keyboard. It responds on the TV screen, presenting results of its labors in words, pictures, tables and graphs. It's by PolyMorphic Systems, 460 Ward Dr., Santa Barbara, Calif. 93111.

COMPUTER REVOLUTION

The microprocessor "brain" in your computer takes your commands and information, does its calculations and responds by instructing motors, switches or indicators to perform. It

even monitors its own actions and tells you what it's up to.

How much for all this? Get in with a starter hobby kit for about \$100. Advance to \$2500 or more if you like.

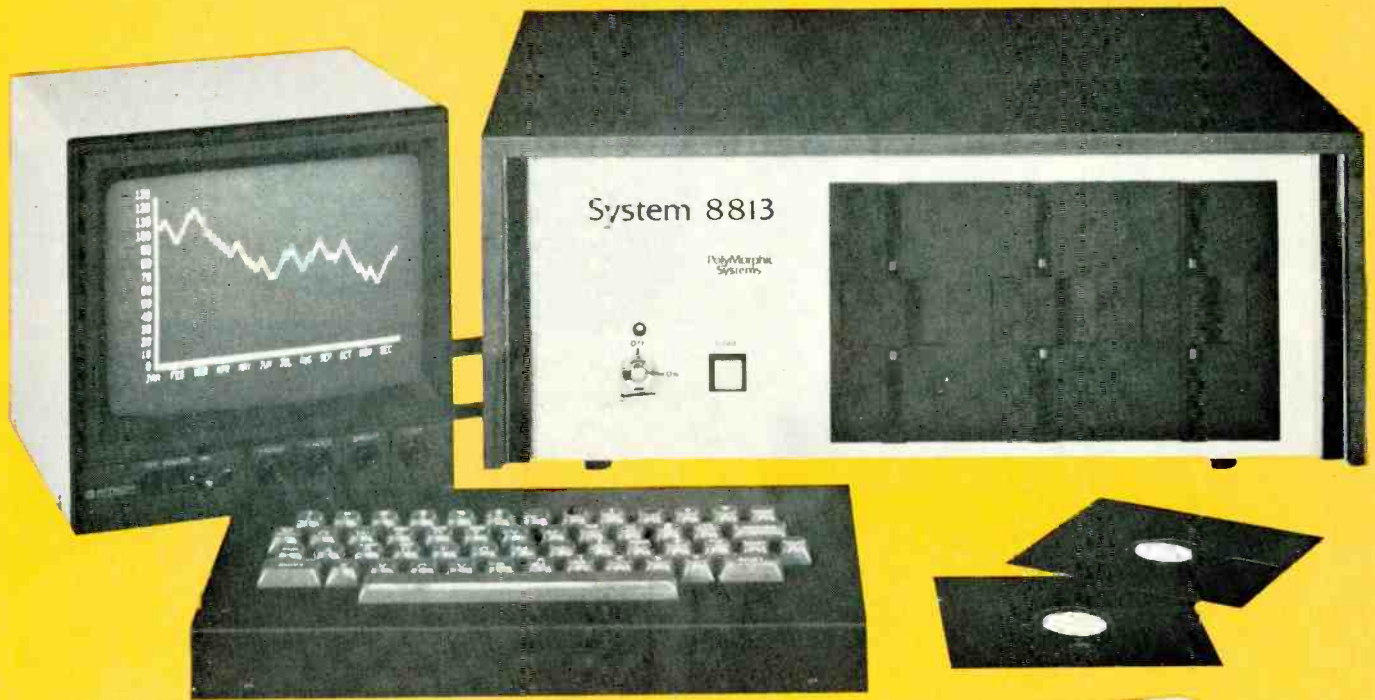

System 8813 from PolyMorphic, 460 Ward Drive, Santa Barbara, Calif. 93111, is useful for novice or experienced programmer.



Your computer takes orders as you type on the keyboard and it prints responses on this DEC Writer II from Heath Co., Benton Harbor, Mich. 49022.



Heath H9, above, is for communicating with the electronic innards of your computer. MITS Altair Minidisk, below, adds lots of storage to your computer's memory.

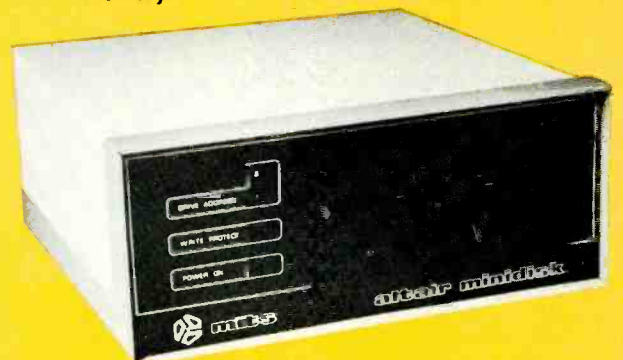



Heath H-10, above, is a different input/output device which reads holes punched in paper tape and punches new tape.



CT-64, above right, from Southwest Technical Products, 219 W. Rhapsody, San Antonio, Tex. 78216, is a video display which prints black on a white background when needed.

But shop carefully for prices compared with specs. Good complete systems now can be had off the shelf for \$600.

To get started, you'll need a central processing unit (CPU). Input and output (I/O) gear, like a Teletype or a video display terminal, will let you command the machine and get its written response. And lots of extra memory will be important to most home applications.

It's a heck of a lot cheaper hobby than cars, boats or planes. For the price of a color TV or a classy stereo amp you can plant both feet firmly in the new era. ☐

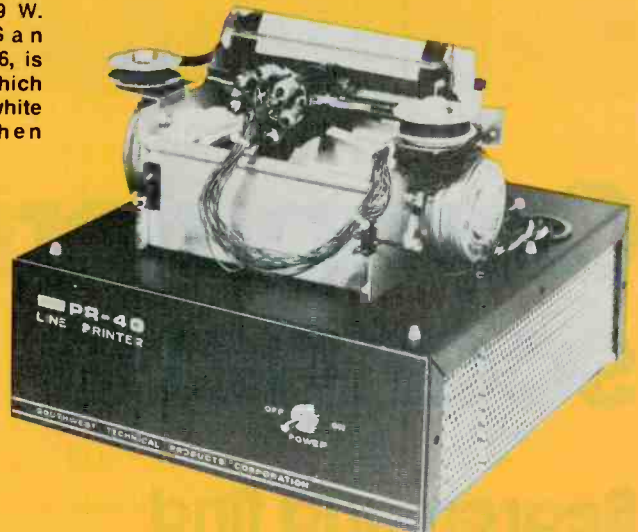

Southwest Technical Products' PR-40, right, a computer output device, is a low-cost kit which prints 75 lines of 64 letters and numbers per minute.

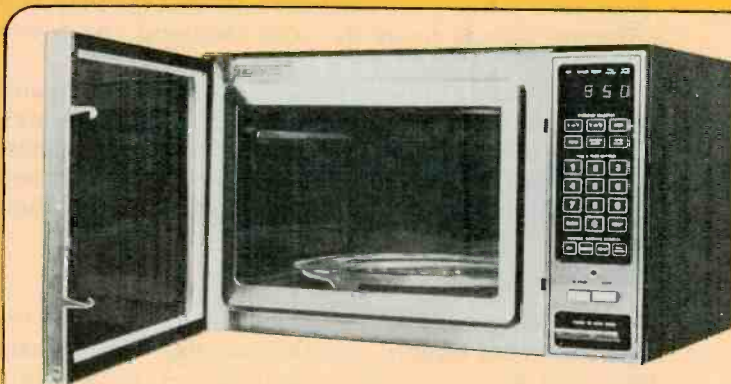

Not all microcomputers look like hobby rigs. More and more computers are being tucked away, inside familiar appliances. Sharp Electronics has a tiny computer controlling a microwave oven, above. Sears breaks new ground with microcomputers in Lady Kenmore washers, right, dryers and dishwashers. You program the computer in the washer to perform any of 12 different wash functions. The computer does the rest.

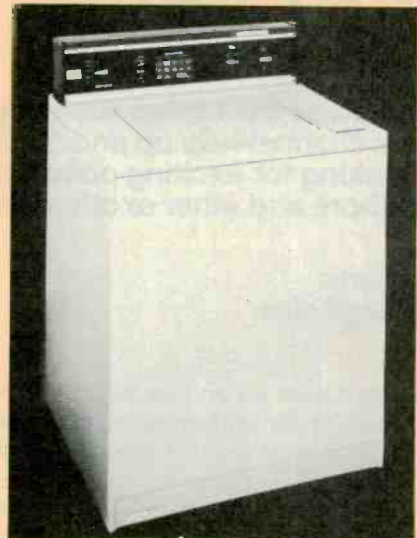

The Touch is Regency's search-and-scan 15,357-channel monitor receiver.

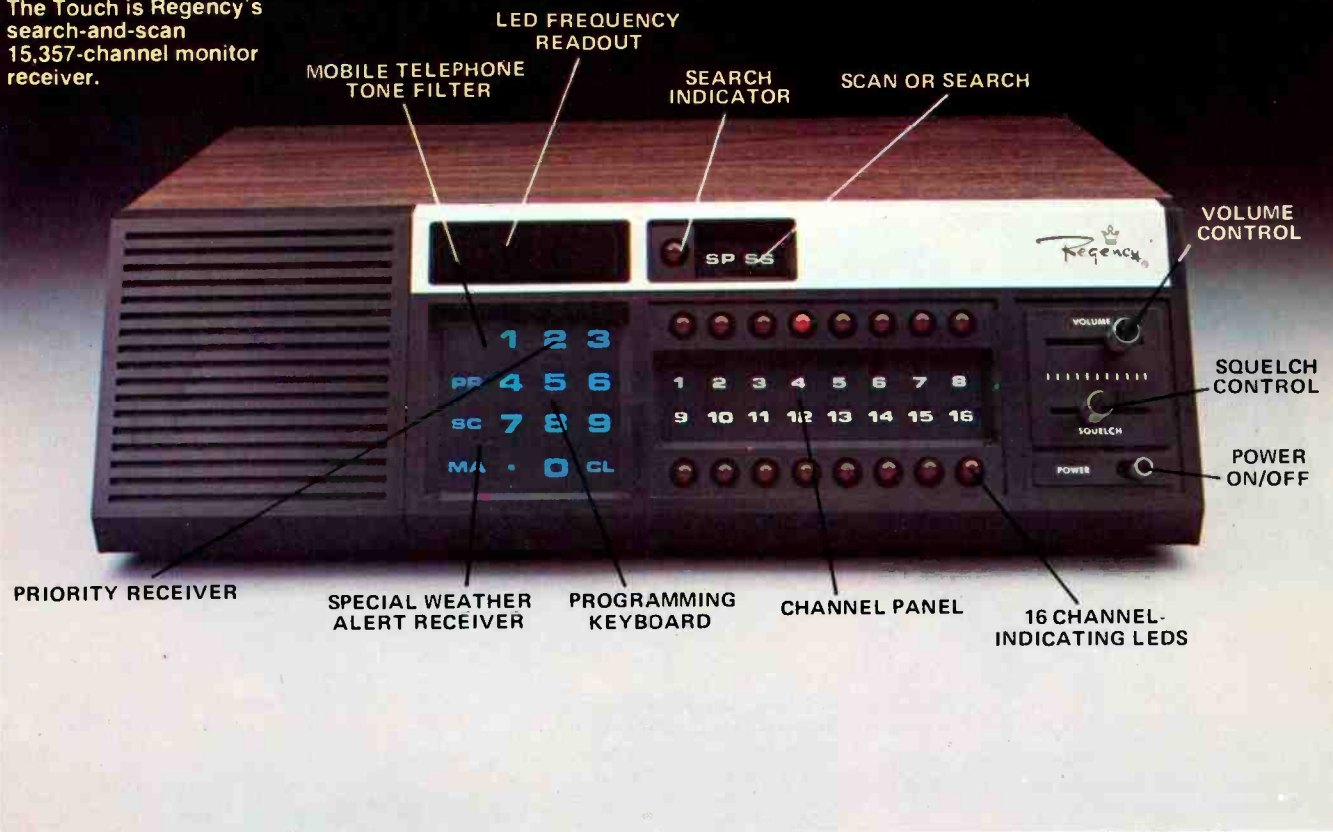

Computerized scanners:

Search and find mystery signals

1978 computer-controlled scanning monitor receivers channel-hop up and down entire bands looking for exciting police, fire, ham, ship-to-shore and other exotic signals.

by Judy Curtis
Contributing Editor

There was a time when you had to corner a cop and ask for a peek at the bottom of his radio to find out the frequency your local police talk on. And then you had to plunk down \$5 a crystal for each police, fire, ambulance, ham, or marine channel you wanted to scan in your monitor receiver.

No more! Now, for the old price of a scanner plus

one load of crystals for a dozen channels, you can buy a receiver to search through *thousands* of channels. Hour-after-hour, your machine will look for new and different signals to excite your listening. And you won't buy even one crystal for it.

Touch a finger to the scanner's digital keyboard and you set your own private signal seeker on the search for secret police chatter, downed-aircraft hunts, newsmen telling their editorial desks what really happened behind the lines, or harbor pilots gabbing with their wives.

\$75,000 rocks

You can program your receiver to search your favorite frequencies tonight and then change the program tomorrow in search of unknown signals. It's a radical new departure for public-service-band listening. The new sets have the latest digital electronics:

- Digital synthesizers are used instead of crystals for frequency determination.
- Digital memories store and recall frequencies you want to hear again.
- Digital keyboards let you have complete command of all receiver operations at the touch of a

fingertip.

■ Digital readouts display actual frequencies of mystery signals being received from unknown stations.

■ Digital microprocessors control the whole works.

Not buying crystals, you save \$40-\$100. And it would cost \$75,000 if you were to buy rocks for the 15,357 channels scanned by Regency's radio.

At the same time, you won't have to keep lists of frequencies for which you own crystals. Big red LEDs (light-emitting diodes) spell out exact frequencies of signals you receive. Memories store that frequency information so you can get back there fast when action starts.

You can toss out your old scanner code book. The first generation of digitally-synthesized scanners merely replaced crystals with electronic circuits. You looked up in a code book a frequency you wanted to monitor and keyed special numbers into the scanner. The new generation of synthesized machines lets you punch in exact frequencies. For instance, if you wanted to hear an amateur radio repeater on 146.940 MHz, you would tap in 146.94 on the radio's keyboard.

Here's a rundown on the best second-generation sets:

Bearcat 210

Electra Company, Cumberland, Ind., one of the best-known manufacturers of scanners, gives coverage of a wide chunk of the VHF and UHF radio spectrum in the Bearcat 210. The rig can be programmed to search any frequency from 32-50 MHz; 146-174 MHz; and 416-512 MHz.

You load any of 10 of your favorite frequencies into the 210 and it will scan them. Or you can fire it off on a search of any of the three bands from 32-512 MHz, looking for whatever it can hear. It tunes rapidly across a band at a rate of 20 channels per second. It is very sensitive to weak signals, even when using its built-in telescoping whip antenna.

Bearcat 210 has a feature long needed by public-service listeners: a filter to screen out idle tones used on mobile telephones. The scanner keeps right on searching when it comes to a channel tied up by a tone. However, if any other audio is on that frequency, the scanner will lock up and let you listen in.

The Touch

Regency Electronics Inc., Indianapolis, Ind., has one of the most versatile of the new sets in a model called The Touch. Along with the search-and-find operation,

The Touch has a built-in priority receiver which sits back and listens to a channel you have specified as top priority. When a signal comes in on that frequency, The Touch switches to that channel. You never miss a call on your favorite frequency.

The Touch also will stand by on the National Weather Service frequency, even as it scans other frequencies, to sound an alert if NWS transmits a special tone indicating severe weather is coming.

The Touch covers 30-50 MHz, 146-174 MHz and 440-512 MHz. It can search 12 channels per second.

Radio Shack PRO-2001

The Realistic scanner covers six segments of the radio spectrum: 30-50 MHz VHF low band; 144-148 MHz two-meter ham band; 148-170 MHz high band; 430-450 MHz ham band; 430-470 UHF low band; and the new UHF high "T" band from 470-512 MHz. It has 16 programmable channels plus a seventeenth in the monitor button.

These scanners are in the \$250-\$400 price range, have built-in loudspeakers and are powered by both 110-volt ac house current and 12-volt dc car or boat battery.

Here's how they work. The receivers have front-panel keyboards through which you enter frequencies, start searches or program normal scanning. Suppose you want the Bearcat 210 to search the frequency range of 152 to 153 MHz for unknown mobile telephone calls. You key in 152.000 and press a key labeled "lower." Then punch in 153.000 and press "upper." Now press "start" and the automatic search begins. To stop the search or stay on a frequency after the machine has stopped, depress "hold."

Scanning your favorite 10 channels in the Bearcat 210 is accomplished by programming your selection of frequencies into the 10 available memory locations. For instance, if your local police operate on 154.655 MHz, you punch in 154.655 and the "E" key to place the police frequency numbers into the radio's memory. Press "scan" and the rig starts looking over the 10 channels you like. Push "manual" to stop the action or to step forward one channel at a time.

You can hold onto a channel for a couple of seconds after a signal disappears by programming "delay" into the memory. Or you can "lock out" a channel, causing the receiver to overlook it.

There's a world of unusual and exciting radio signals waiting to be heard. You'll be surprised at just what you can hear once you have one of these computerized scanners on the job hunting down secret transmissions. □

Realistic PRO-2001 searching digital scanner from Radio Shack monitors 16 channels you program in, or it looks through any range of frequencies you pick for mystery signals. Monitor button adds a seventeenth channel. LEDs display exact frequency being received.



At CIE, you get electronics career training from specialists.

If you're interested in learning how to fix air conditioners, service cars or install heating systems – talk to some other school. But if you're serious about electronics, come to CIE – The Electronics Specialists.

John E. Cunningham

**Special Projects Director
Cleveland Institute of Electronics**



My father always told me that there were certain advantages to putting all your eggs in one basket. "John," he said, "learn to do one important thing better than anyone else, and you'll always be in demand."

I believe he was right. Today is the age of specialization. And I think that's a very good thing.

Consider doctors. You wouldn't expect your family doctor to perform open heart surgery or your dentist to set a broken bone, either. Would you?

For these things, you'd want a specialist. And you'd trust him. Because you'd know if he weren't any good, he'd be out of business.

Why trust your education and career future to anything less than a specialist?

You shouldn't. And you certainly don't have to.

FACT: CIE is the largest independent home study school in the world that specializes exclusively in electronics.

We have to be good at it because we put all our eggs in one basket: electronics. If we hadn't done a good job, we'd have closed our doors long ago.

Specialists aren't for everyone.

I'll tell it to you straight. If you think electronics would make a nice hobby, check with other schools.

But if you think you have the cool—and want the training it takes—to make sure that a sound blackout during a prime time TV show will be corrected in seconds—then answer this ad. You'll probably find CIE has a course that's just right for you!

At CIE, we combine theory and practice. You learn the best of both.

Learning electronics is a lot more than memorizing a laundry list of facts about circuits and transistors. Electronics is interesting because it's based on some fairly recent scientific discoveries. It's built on ideas. So, look for a program that starts with ideas—and builds on them.

That's what happens with CIE's Auto-Programmed® Lessons. Each lesson uses world-famous "programmed learning" methods to teach you important principles. You explore them, master them completely... before you start to apply them!

But beyond theory, some of our courses come fully equipped with the electronics gear to actually let you perform hundreds of checking, testing and analyzing projects.

In fact, depending on the course you take, you'll do most of the basic things professionals do every day—things like servicing a beauty of a Zenith color TV set... or studying a variety of screen display patterns with the help of a color bar generator.

Plus there's a professional quality oscilloscope you build and use to "see" and "read" the characteristic waveform patterns of electronic equipment.

You work with experienced specialists.

When you send us a completed lesson, you can be sure it will be reviewed and graded by a trained electronics instructor, backed by a team of technical specialists. If you need specialized help, you get it fast... in writing from the faculty specialists best qualified to handle your question.

People who have known us a long time, think of us as the "FCC License School."

We don't mind. We have a fine record of preparing people to take... and pass... the government-administered FCC License exams. In fact, in continuing surveys nearly 4 out of 5 of our graduates who take

the exams get their Licenses. You may already know that an FCC License is needed for some careers in electronics—and it can be a valuable credential anytime.

Find out more! Mail this card for your FREE CATALOG today!

If the card is gone, cut out and mail the coupon.

I'll send you a copy of CIE's FREE school catalog, along with a complete package of independent home study information.

For your convenience, I'll try to arrange for a CIE representative to contact you to answer any questions you may have.

Remember, if you are serious about learning electronics... or building upon your present skills, your best bet is to go with the electronics specialists—CIE. Mail the card or coupon today or write CIE (and mention the name and date of this magazine), 1776 East 17th Street, Cleveland, Ohio 44114.



Patterns shown on TV and oscilloscope screens are simulated.

CIE Cleveland Institute of Electronics, Inc.

1776 East 17th Street, Cleveland, Ohio 44114

Accredited Member National Home Study Council

YES... John, I want to learn from the specialists in electronics—CIE. Send me my FREE CIE school catalog—including details about troubleshooting courses—plus my FREE package of home study information. MO-01

Print Name _____

Address _____ Apt. _____

City _____

State _____ Zip _____

Age _____ Phone (area code) _____

Check box for G. I. Bill information: Veteran Active Duty

Mail today!

Ahoy, the dinghy!



From the Chesapeake Bay to San Francisco, wherever boatmen and Sunday sailors get into trouble, their first reaction is to grab a VHF radio microphone and call the Coast Guard. They've had to dive into cockpit or cabin to a large bolted-down transmitter. Now you can carry safety on your belt. Lounging on the foredeck or rowing a dinghy a half-mile from your boat, a handheld portable radio can be on hand when you need it.

by Anthony R. Curtis

ME graphics: Color Directions

Good news! Spring is just weeks away, according to that Punxsutawney groundhog. That means it's time to turn your attention to fixing up the powerboat or sloop for the new season. The big hit in marine electronics this year is going to be handheld VHF radios.

The Federal Communications Commission has liberalized its rules so you

now can enjoy the freedom of movement about the waterways provided by one of these two-way fm transceivers. Now you can use your radio away from your main boat.

A handheld radio is perfect for the owner of a small boat without room for bolting in a larger set; for the fisherman who wants to protect his gear by taking it off the boat after every trip; for the sunlover who prefers hours on the foredeck to standing by a radio in the cabin. With these little transceivers, a casual boatman can have the Coast Guard, passing boats, telephone calls or even weather broadcasts as close as an arm's reach wherever he is stationed. You can even take one of these gems along in the dinghy when you row over to a quiet lagoon for some shuteye away from the family.

You can get a radiotelephone station license for your boat by completing an application and mailing it to FCC, Box 1040, Gettysburg, PA 17325. The delay in getting a boat station license back from the FCC has been up to six months. You can take your completed application in person to an FCC field office near you and have the license handed back over the counter for immediate use.

The station license allows you to have a radio in your boat. You'll also need a restricted operator's permit to legally

use that radio. Applications for restricted permits should be mailed to FCC, Box 1050, Gettysburg, PA 17325, or pick one up at a field office.

Portable license

If you know ahead of time that you will be using a handheld radio, add that information to your radiotelephone station license. Your license then will have the extra endorsement "portable".

Handhelds are used the same way you would a larger radio on board. The Coast Guard can be summoned in emergencies. Other boats can be hailed. Calls ashore through the telephone company's landlines can be completed. Broadcasts from the National Weather Service can be monitored if you use up one of the channels in your handheld for a WX-receive crystal (no transmitting allowed on WX channels). The small radios work on the same channels, between the frequencies of 156-162 MHz, as their bigger brothers.

The FCC requires all marine radios be sold with at least emergency channel 16 and ship-to-ship channel 6 ready to work. So, all handhelds as well as larger sets come with crystals for those two channels. In addition, the FCC recommends that all VHF fm marine radios have the capability of operating on at least one "public correspondence" channel so you can make landline tele-



Model 1505 battery-powered handheld portable two-way radio from Wilson Electronics, Las Vegas, NV 89119 is the same for freighters, above, or your powerboat, top of page.



Portables like Triton from Motorola, Schaumburg, IL 60172, have channels 16 and 6 for calling Coast Guard or other boats plus more-private channels of your choice for personal dinghy-to-sloop communications.

phone calls through marine operators ashore.

The FCC also would like you to install crystals for channel 68 in your radio. That channel is a boat-to-boat frequency for non-commercial pleasure vessels. After making an initial contact with another boat on channel 16 or 6, you would switch to 68 to continue communication.

Small packages

Despite their size, these radios have large technical specs. They have receivers as hot as most larger 25-watt sets. Receivers are as selective as many bigger radios, able to reject signals transmitted on channel 17 as you listen to 16.

Range of a handheld is up to five miles boat-to-boat on open water. Range might be a bit longer boat-to-shore if the antenna ashore is high in the air. For instance, the Baltimore marine telephone operator on channels 25 and 26 in Maryland regularly reaches out 30-40 miles to radios on boats. A hand-

held portable might be good for telephone calls up to 15 miles away from the Baltimore marine operator's high antenna. Coast Guard antennas usually are equally high and contacts over relatively long distances are possible with handhelds.

The higher the better

Antenna height is more important than transmitter power in a VHF fm radio of any size. And some handhelds have standard antenna connectors so you can unscrew the rubber ducky and attach a larger, higher boat-mounted antenna to improve range.

Watch out! You can drop a handheld overboard and lose hundreds of dollars. These radios can cost more than \$500.

Another disadvantage is the very thing which makes them portable: batteries. Most handheld circuits require 12 volts direct current (dc) just as circuits in larger radios. A handheld's power often comes from either eight penlight-size throwaway batteries or 10 penlight-size rechargeable batteries. A couple of days listening and just a little bit of transmitting drains throwaway batteries at a cost



Smooth-working squelch on handheld from Regency Electronics, Indianapolis, IN 46226, allows quiet monitoring of unused channels.



Marine handhelds, like model SR-C830S50 from Standard Communications, Carson, CA 90248, are rugged solid-state construction with built-in microphone and loudspeaker.

of \$2-\$5 per set. Your better bet probably will be rechargeable batteries. A set may cost \$20 or more plus the cost of the charger, but you'll save money in the long run.

You can buy a charger for use with shorepower and, sometimes, one for use with your boat battery. You'll need the boat-battery recharger if you use the radio for an extended period of time on board without shore power.

Add ons

Accessories include an external microphone and external loudspeaker. Handheld radios usually are lifted near the mouth for transmitting. Some manufacturers offer a small combo mic and speaker on a long coil cord. Connecting the speaker-mic cord to the handheld permits setting the radio on a deck or cabin table or even keeping it attached to your belt while you row along in the dinghy. You talk into the small speaker-mic. Sound comes out of it.

Handheld portables cost as much as their big brothers—\$300-\$700. But the convenience may be well worth it! 

Here's what to shop for in a VHF fm radio for your boat

When you stop by your local marine electronics shop to check out radios, look for these important technical specifications:

■ **Channel capacity.** You'll want at least channels 16 and 6 for emergencies and other calls. Additional channels will provide more-private calling frequencies. For instance, when you have made contact with another boatman on 16 or 6, you'll want to switch to channel 9 to complete communications, leaving 16 and 6 open for others.

■ **Receiver sensitivity.** The weaker a signal a receiver can hear, the better the radio. Signals often are measured in "microvolts (uV) at 20 decibels (db) of quieting." A receiver which could not hear a signal weaker than 0.5 uV would not be as sensitive as one which could hear a weaker 0.3

uV signal. The smaller the sensitivity number, the better.

■ **Receiver selectivity.** If you are listening on channel 16, you don't want to hear a station bleeding over from an adjacent channel. Selectivity is the ability of a receiver to reject signals on nearby channels while letting you hear the channel you are tuned to. You want maximum selectivity so look for the largest number.

■ **Intermod rejection.** When other strong transmitters are operating near your radio, the signals may mix inside your set and cause intermodulation noise. The more attenuation of intermodulation, the better. The larger number here is better.

■ **Audio power.** The watts pushing your receiver's loudspeaker are important. A boat gets noisy under power and you want to hear a call. The more receiver audio out-

put power, in watts, the better.

■ **Antenna.** Handhelds have either stainless steel whip or rubber-covered flexible antennas. The "rubber ducky" antenna is shorter and less breakable than a whip which can get bent. But the slightly-longer whip antenna is more efficient at sending your radio signal out into the air. You may appreciate the rubber-covered antenna more, in the long run, even if it is an extra-cost option.

■ **Rechargeable batteries.** Compare costs of adding new throw-away batteries regularly with the one-time price of rechargeables plus charger. You may want an adaptor to power your radio directly from the boat battery in an emergency if the handheld's internal battery should go dead. You'll need two separate chargers if you plan to plug into the dc system on your boat sometimes and into ac shore power sometimes.

gear parts tests books

The editors roundup exciting new products you should know about.



Experimenter's scope

Heathkit's new oscilloscope, the Model IO-4555, offers many features found only on laboratory-grade instruments. One of these is the X5 magnifier that lets you expand a small section of the trace by a factor of five. The vertical amplifier has 10 MHz bandwidth, more than enough for most TV servicing work, and a sensitivity of 10 mV/cm. It's \$299. For more information, circle number 182 on the reader-service card.



Sink that sub

Here's an exciting electronic game to play without tying up the television screen. In *Code Name: Sector* by Parker Brothers, a computer chip and programmed logic circuits supply players with information needed to track and attack a hidden submarine. Each player captains his destroyer across the nautical chart playing board. New positions are readout by the computer in digital display. There's lots of fast-paced action as players' destroyers attack the computer's submarine. If the depth charge misses the sub, the sub fires back. Once one secret sub is sunk, another comes into play, so the siege can continue as long as players charge on. While designed for ages 12 and up, strategy needed to sink the computerized sub is a challenge for all ages. It's \$40. For more information, circle number 181 on the reader-service card.



Quartz car clock

No more need to ask for a 10-36 with this quartz crystal LED clock mounted in your car dash. This clock by Sparkomatic Corp. constantly displays hours and minutes in large, bright numerals. And it's accurate to within one minute a year. Time setting is easy with hour and minute buttons on the front. You can mount the Sparkomatic clock in any car, camper, van, pickup, boat, or other vehicle with a 12-volt electrical system. Unlike ordinary car clocks, this unit has no moving parts to go bad. It's \$43. For more info, circle number 180 on the reader-service card.



Integrated amp

Kenwood's new KA-7100 integrated stereo amplifier eliminates the distortion introduced in most other units by the coupling networks built into their circuitry. Kenwood has done this by designing the KA-7100 as a dc amplifier, which has no coupling networks. The result is virtually flat response from dc to 100,000 Hz with less than 0.02 percent distortion. It's \$300. For more information, circle number 170 on our reader-service card.

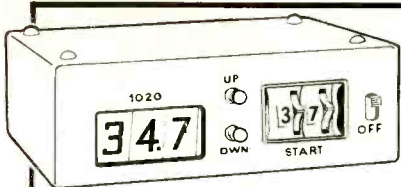

Mile marker

Do you feel lost on the turnpike, somewhere between mile marker 100 and 250? If you do a lot of freeway driving and want to know exactly where you are, install the C. W. Inc. model 1020 Indicator. Install and calibrate the \$60 unit in less than 30 minutes. The exact mileage to within a tenth of a mile displays on large LED digital readout. For more information, circle number 172 on our reader-service card.

Four-way TV



Carry eight pounds of pure entertainment over your shoulder anywhere you go with Webcor's portable mini television. Receive VHF and UHF channels plus all your favorite am and fm radio stations with

this one convenient set. Plug it in your wall; hook it into car, van or boat; run it on a rechargeable battery pack or use eight D-cell batteries. No matter where you are, you can take the Webcor with you. A

telescoping monopole antenna is built in, or easily hook up an outdoor antenna to the external antenna terminals. VHF and UHF tuner is fully electronic plus an electronic tuning eye brings in am and fm signals. The 4½-inch tv screen shows fine picture definition and brightness. A shadow mask around the screen makes daytime viewing pleasant. A built-in stand tilts the set upward. The rich brown cabinet and modern aircraft-type tuning knobs and dials complete a sleek package you'll want to cart everywhere. It's \$199. For more info, circle number 179 on our reader-service card.

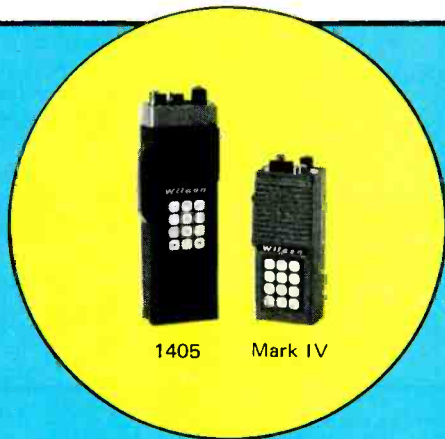
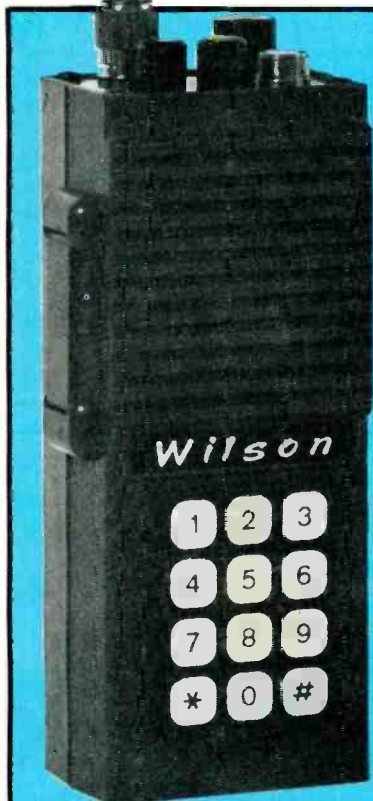

Tiny two-way

Here it is! The smallest handheld VHF fm two-meter transceiver for amateur radio operators is on the market from Wilson Electronics.

Slightly bigger than a cigarette pack, the new Mark II (\$199) and Mark IV (\$239) portables are about half the size of their predecessors, the 1402 and 1405 models. Mark II transmits 2.5 watts of power and the Mark IV runs four watts. Both have six channels and use standard Wilson crystals. Both use rechargeable batteries.

Receiver and transmitter specifications match Wilson's other quality handhelds. For more information, circle number 178 on our reader-service card.

Auto amp with equalizer



Boost your car stereo or radio with "Audio Max" model AMP-1000 from Audiovox. The amplifier can be used with any car stereo or radio to increase output by 22 watts per channel. A convenient mini handheld remote control unit sits upfront with you to control the amplifier hidden away under dash, seat or in trunk. Controls include volume, bass, mid-range and treble slide-bars. Full frequency response of 60 to 15,000 Hz. Audio Max (\$120) works with your existing car speaker system. For more information, circle number 173 on our reader-service card.

Super meter



The Conway Masterranger MK II/A is a Canadian multimeter with very unusual features. For example, the input impedance is 100 megohms, far greater than most VTVMs. It can measure voltages ranging from 50 microvolts to 50,000 volts, currents from 5 microamperes to 150 amperes, and resistances up to 10,000 megohms. In addition, it also measures temperature from -150 degrees to +500 degrees Celsius. It's \$240. For more info, circle number 177 on our reader-service card.

High-velocity phones



Let your ears breathe with Mura's "8-hour" stereo headset. Vented high velocity construction avoids listening fatigue. The light-weight polymer film diaphragm gives exceptional distortion-free low and high frequency response. Individual volume controls for each ear create perfect stereo balance. The phones are \$45. For more information, please circle number 176 on the reader-service card.

SSB CB

RCA's new Model 14T302 Co-Pilot CB radio packs into its 7½ x 2½ x 7¼ case operating features you've always wanted in a deluxe 40 channel single sideband transceiver. LED digital readout displays the channel. A dimmer lightens or darkens display for night or daytime driving. This control also adjusts brightness of the meter which does triple duty as a signal strength, transmitter output and antenna SWR check. With the clarifier control, you can fine tune SSB signals plus tune in slightly off frequency am signals. And there's a local/distance switch to adjust receiver sensitivity to prevent over-



load from strong signals. Co-Pilot lists at \$299. For more information, circle number 175 on our reader-service card.



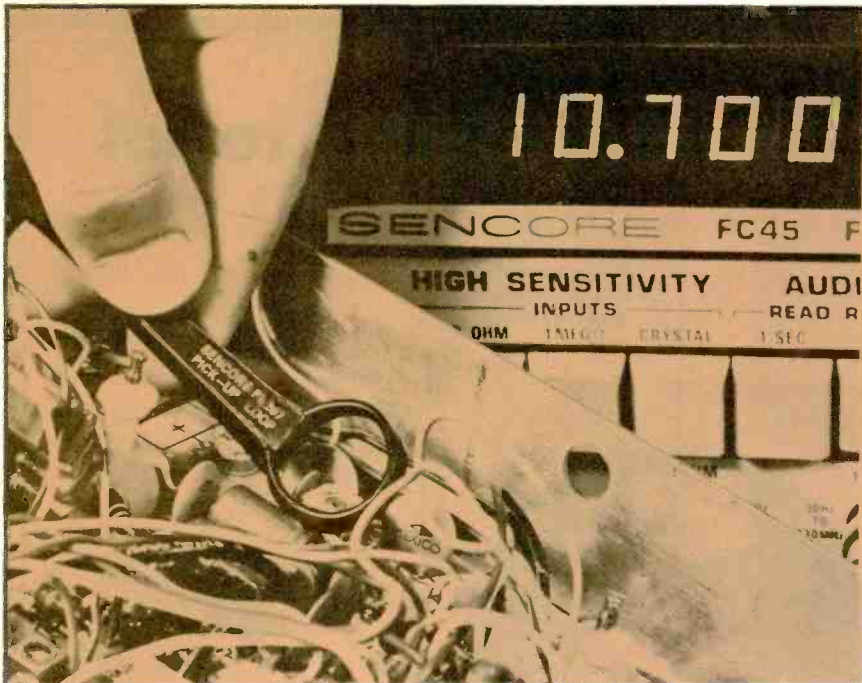

Snoop loop

Uncover mystery signals with a snoop loop. This closed loop picks up signals and measures frequency without connecting to the circuit. Connect it to the 50 ohm input cable of any frequency counter. You protect yourself from shock and your test equipment from damage since you're not connected to the circuit.

You can retrace the signal path through all circuits to the oscillator coils, without upsetting the operating frequency. If you ever have to measure frequency in a hot circuit, you'll appreciate the convenience of Sencore's snoop loop (\$10). For more information, circle number 174 on the reader-service card.



SWL rig

Teak wood sides. Brushed aluminum panel. Textured black enamel finish. The McKay Dymek DR-22 is a shortwave listener's receiver loaded with lots of goodies and pizzaz. A five-digit LED readout flashes the frequency being received. Select frequencies with four rotary switches and a fine tuning control. This fully synthesized receiver covers 50 kHz to 29.7 MHz. You'll be able to select between weak signals with crystal filters and switch-selectable ceramic band-pass filters. The receiver is sensitive and selective so your listening enjoyment includes more than just strong signals. Once tuned, the DR-22 (\$995) locks on frequency with quartz crystal accuracy and stability. For more information, please circle number 171 on the reader-service card.

Rank Leak

A new full-range speaker system has been introduced into the U.S. by Rank Hi Fi. The unique design of the Leak 3050 system employs two 6½" woofers and a ¾" dome tweeter fed through an 11 element crossover network. Frequency response for the system is claimed to be from 48 Hz to 22 kHz. According to the manufacturer, the computer generated design compensates for time delays that are generated in most speaker systems. The result is said to be "startlingly realistic" sound. The Leak 3050 is rated at 50 watts, measures 25½ x 11¾ x 13¾, and weighs 42 pounds. They are sold only in matched pairs for \$700. For more information, please circle number 169 on the reader-service card.



**gear
parts
tests
books**

Here's Mel, our do-anything robot

Mel's a figment of our imagination, but not for long, we hope! Whatever his final specs, we'd like to see Mel for real one of these days...

Super high-gain UHF two-way telemetry and command radio antenna for contact with sensors.

Mel can look in any direction, pivot on a dime and reach the highest shelf in your library for a book.

"Arm" attachments convert Mel into the home handyman.

Mel is equipped with a built-in fire extinguisher for those little emergencies that crop up from time to time.

Mel can display charts, graphs, maps and other designs on his built-in computer output devices.

Mel can prepare over 200 different mixed drinks.



Picture from video intercom at front door of house.

Mel is a calculator, computer, controller, and entertainment center of the finest rolling stock.

Mel's stereo receiver spreads music throughout your home.

Microwave oven.

Dust and ash receptacle.

Telephone dialing pad for the occasional number you forgot to store in Mel's memory.

Complete weather center provides current temperature, humidity, and barometer readings as well as receiving NOAA broadcasts.

Soft rubber tread wheels Mel at your beck and call.

Vacuum cleaner.

ME art: Jack Doyle



**At last.
The complete inside story.
What it takes to set up your
own
home computer.**

Here's the low down on exactly what you need to set up your own personal computer system. What to buy. How much it'll cost. How to set up the gear.

by Peter A. Stark
Contributing Editor

The time has come when you can go into a store and walk out, for the price of a color tv set, with a home computer. With the easy availability of all types of computers, there are two questions the electronics enthusiast wants to know—*why* and *how*? Why get a home computer and what can you do with it, and how do you get started? The two questions are related because what you want to do with it determines how to get started.

People have been building and buying home computers for quite a few years, even before the invention of the *microprocessor* which started the current boom. They have done it as a hobby, for entertainment, as an aid in another hobby, for education, for help in running the home, and to make money.

First and foremost, a computer can be fun, recreation, entertainment, and *anything* else you want it to be. All by itself it makes an excellent hobby, much better than stamp collecting, wood carving or a thousand other hobbies. Put another way, it is a hobby for the mind rather than for the body.

For some, a computer is an end in itself. Quite independent of what it can do, it is a machine which reacts to its owner's actions. For some it is a slave which follows their wishes instantaneously and without complaint; for some it is a companion for a game; for still others it is something to pit their brains against. Just as you can love a dog or cat, so you can love a computer!

Sometimes, a computer is a game. Even a small computer can be programmed to play more games than the most expensive electronic tv game. Not just action games like hockey, tennis or tank, but also word games, picture games, guessing games, math games. Besides buying pre-programmed games, the computer hobbyist can write his own or trade them with others.

Many games can be educational as well. On a large scale, CAI or *computer aided instruction* has been tried and tested in thousands of schools around

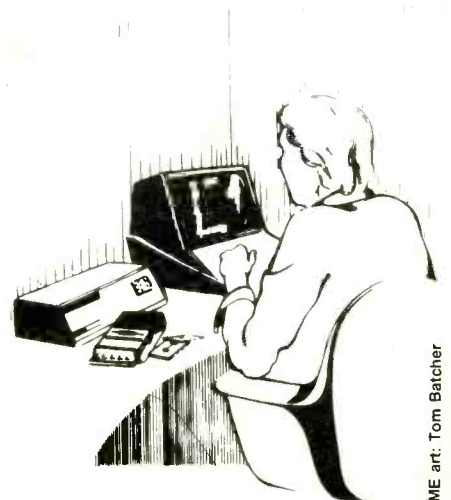

ME art: Tom Batcher

the country, and found to be very effective. In simple cases, a computer can be like a drill sergeant, providing drill to youngsters in arithmetic, spelling, history or geography.

Helping us learn

In more advanced cases, computer simulations have been used by graduate schools in training business executives. The computer sets up a typical business situation involving products, inventories, competition and all other aspects of business, and students react to these elements by making various business decisions. The computer calculates the effect of their decisions on their company or industry, presents them with the results of what they have done and lets them make further decisions. Between grammar school and graduate school, there is tremendous range of possible applications for computers in replacing or helping teachers.

Sometimes people get a computer to help them in another hobby. Some model railroad buffs have connected their

computer to their model railroad to automate track switching, train routing, control of train speeds, and even control of train crossings. It is exciting to watch several trains move back and forth over a complex track set at high speeds, crossing in front of each other, waiting for faster trains at rail sidings, and in general keeping busy without once crashing into each other.

An extra hand

Radio amateurs also have taken to computers as accessories to their hobby. Some use a computer to automatically keep their beam antennas pointed at a ham radio satellite as it crosses overhead. Others log a file of their long distance contacts in their computer so the next time they contact the same station, their computer quickly recalls for them the other ham's name, location, and equipment. By interfacing a computer to a radioteletype (RTTY) station, an amateur radio operator can receive messages over the air even in his absence. Some ham computers even have been pro-

grammed to copy Morse code sent over the air and provide a printed listing of what is being sent.

In addition to helping in another hobby, a computer can help around the house. Housewives will be unhappy to hear that the computer can't yet clean the house by itself, but perhaps that day yet will come. In the meantime, balancing a checkbook is a useful job that needs doing once a month as the bank statement arrives. Although a calculator can do the additions and subtractions just as well, it cannot reconcile the bank statement with the checkbook stubs to match up date, check number, and amount, keeping track also of deposits not yet posted to the account by the bank, and checks written but not yet cashed. A computer can.

A common example of a chore the computer can do is maintain a recipe file. And, calculating the calorie content of foods, keeping track of foods in the pantry and preparing a master shopping list every week based on that inventory are perfectly feasible useful jobs. Better yet, how about having a shopping list printed out in the same order as the merchandise is located in your favorite supermarket? Then it would be a simple matter of walking down the aisles, picking up items as you pass them.

Another good application is in budgeting your income. By entering all income received as well as all expenses, the computer could maintain a running total of cash on hand. This use probably would require a bit of programming, but think of the advantages each April 15 if you could account for every penny spent on sales tax or gasoline tax, and not have to depend on the tax tables in the IRS forms.

That brings us to making money. Many computer owners are using a small computer in their daily business. The most obvious application is in accounting. A small computer can be used to prepare the payroll, keep track of inventory and accounts owed or to be paid.

The equipment needed by a small grocery store having thousands of small transactions still might be very expensive, but for any businessman dealing with a small number of different items a computer is ideal. This includes, for example, the doctor or dentist who sees a limited number of patients each day and who must prepare monthly bills and keep track of payments.

Another application, of particular interest to book and magazine writers, is text editing or word processing. This involves writing a book or article on a computer terminal instead of a typewriter, and storing the text in the computer's memory.

Using a keyboard and a tv display, the writer can recall parts of the material he has written, edit it to add, change or



remove parts he does not like, and when he is satisfied that it is as he wants it, he can prepare a final typed copy with a perfection no human typist could achieve.

Take it to work

Text editing has been used for years in industry in one form or other—companies use it to type form letters, Congressmen and Senators use it to write individualized letters to their constituents, newspapers and wire press services use it to process news stories all the way from the original writing to the final typeset form which appears in the paper. But not until the home computer has the individual writer or author been able to afford the equipment needed for his own home office.

Finally, a home computer can be used to provide computer services for others. A host of entrepreneurs has arisen in the last year or two to enter the computer business. Small computer shops sell equipment to other small businesses, and nights and weekends their owners work at home developing the programs for that equipment. Accountants who moonlight nights and weekends in the spring preparing tax returns use small computers to help in preparing the tax forms and keep track of the numbers and calculations needed.

In short, the applications of home computers are almost limitless. Each time someone thinks of a new application, he is quickly followed by someone else who thinks of a better one. The next question is *how* do you start and what do you need?

Types of Systems

Home computers come from complete and assembled versions all the way down to partial kits. They can roughly be classified into the following categories:

■ **Complete assembled systems:** costing in the range of \$400 to \$600, Radio Shack's TRS-80 and Commodore's PET are available. Each includes a completely built and tested computer with a keyboard and either a built-in or external tv monitor which is used for output. Since they are built and ready to go, they can be operating within minutes of being taken out of the box.

They are programmed in a simple language such as *Basic*, which is designed for beginners. Programming in this language is easy, and high school and even grammar school kids do it every day. Pre-written programs for a variety of tasks are available so that many users may not ever have to do any programming if they don't want to. As these systems become more widespread, more programs will become available.

Although these systems offer good value, they are designed to be as cheap to manufacture as possible. Thus, they



take some shortcuts which may limit future expansion. They may be perfect if you want them as they are or with slightly more memory capacity, primarily to use for small programs or games and entertainment. If you have visions of ultimately building a super system, they may have large drawbacks.

■ **Semi-complete assembled systems:** there are several assembled systems which are not quite complete, but which still can be placed into operation soon after being unpacked. For example, Ohio Scientific has a \$300 printed circuit board which requires the addition of a power supply and cabinet and either a teleprinter or cathode ray tube (CRT) terminal for operation.

When these are added, this system can be programmed in *Basic* for simple applications. Aside from their need for some work and for a teleprinter or CRT terminal, either of which can be expensive, they have many of the same disadvantages of the complete systems—they may be hard to expand in the future.

■ **Complete-line kit systems:** Heath Co. has the newest line of kits. A number of companies have been in the home computer field long enough to have developed an extensive line of equipment in kit form for putting together a complete system. The three who have been in the field the longest are Altair-MITS, which started the kit computer concept just a few years ago, IMSAI which produces an entire line of products compatible with Altair, and Southwest Technical Products (SWTPC) which introduced a low-cost system shortly thereafter.

All three of these, as well as several

others, produce an entire line of equipment which includes the main computer as well as add-on modules such as extended memory, input and output interfaces, and peripheral equipment such as printers, keyboards, tv video displays, and cassette and disc memory systems. By picking and choosing among options, an excellent system for home or business use can be assembled from any of these. These systems have greater potential for long-term expansion than the complete, assembled systems listed earlier.

However, because of the need to accommodate expansion modules and permit easy connections to them, the price is higher. Even a stripped system costs more than a complete system, primarily because it does not include a keyboard and tv display as part of the package.

■ **Modules from different suppliers:** Other companies make different modules which can be assembled into complete systems. They are easy to connect together because of the existence of several standard interconnection systems, called *busses*.

The starting point for assembling a system is a power supply and motherboard, as well as a cabinet or other mechanical arrangement for holding everything together. The motherboard is a large printed circuit board with up to 100 printed copper wire traces running more or less parallel throughout the entire length of the board.

Connectors for plug-in printed circuit boards holding the other computer modules are then soldered to the moth-

erboard so each connector is connected to each of the parallel traces. All connectors therefore, are tied together through the motherboard. They are essentially in parallel so that pin 1 of the connector is tied to pin 1 of all the others etc.

Some of the smaller systems may have only a small power supply with space for perhaps a half-dozen connectors on the motherboard; larger systems may have more powerful supplies and as many as two dozen or so connector positions.

Since all connectors on the motherboard are in parallel, a plug-in module board may be plugged into any of the empty positions on the motherboard. All that is required is that all the boards within a system use the same pins of the motherboard for the same signal. The assignment of which pin is used for what signal is called the bus structure, and the collection of parallel wires in the motherboard is called the *bus*. When putting together a system consisting of the motherboard and the plug-in boards, it is absolutely necessary to make sure they all use the same bus.

The most common bus structure in the home computer field is the Altair or S-100 bus, since it was introduced first by MITS-Altair on their 8800 computer. The name S-100 comes from the fact that this bus has 100 connections. Although MITS is the originator of the bus, it has been adopted by many other computer system manufacturers as well as small companies that supply just one or two boards to fit the bus.

Another common bus is the SS-50 bus introduced in the Southwest Technical Products MP-68 computer, which has 50 connections. The number of compatible plug-in boards available from other manufacturers is smaller for this bus than for the Altair bus, possibly because the MP-68 computer and its accessories are cheaper, making it harder for small competitors to undercut the price structure with their own products.

There are several other bus structures used, including the 50-pin bus used in the new Heath H-8 computer. It's too new, however, to have led to competitive modules available for it.

The bus is merely an inter-connection scheme, but it is an important one because it permits the expansion of a system. By using a standard bus, it is possible to insert newer modules as they are developed without having to replace an entire system as new developments are available. The motherboard, power supply, and cabinet which are used to support the bus and its components are also somewhat expensive ranging in price from \$200 to \$500.

The heart of the entire system is the central processor board, sometimes called the *central processing unit* (CPU). This board contains the microprocessor

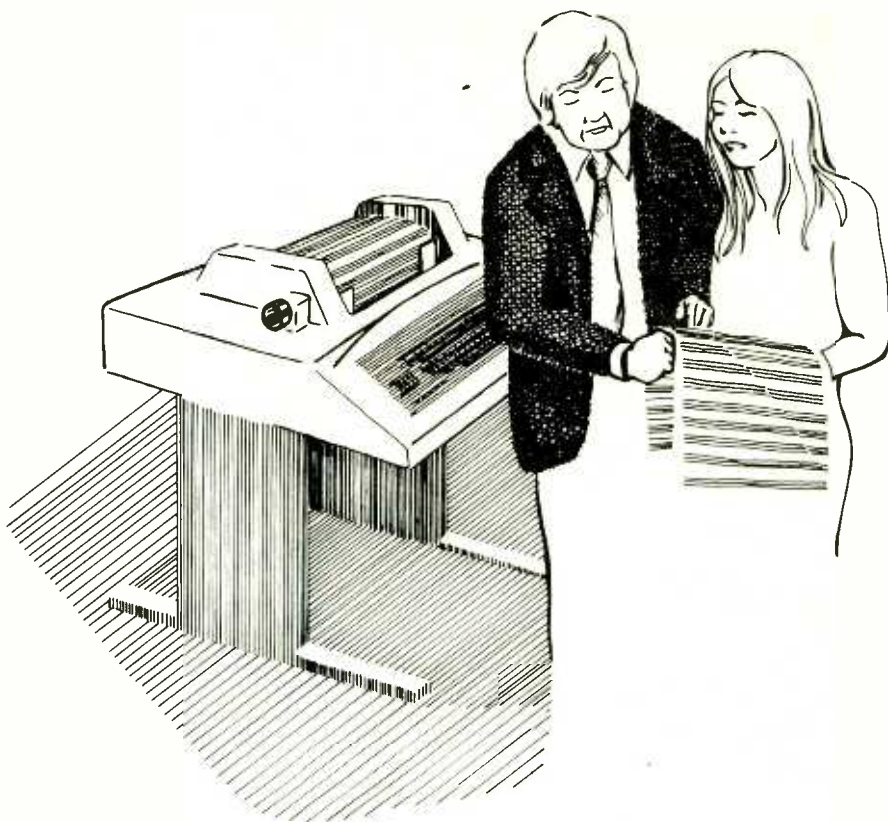

integrated circuit which controls everything, as well as its timing and control circuits, and buffer amplifiers which interface it to the bus. The choice of which bus to use is in many ways tied to the choice of microprocessor.

The original Altair bus was designed for the Intel 8080 micro processor, and most systems using that bus use the 8080. Because of its similarity to the 8080, the Zilog Z-80 IC is also commonly used with the bus, although processor boards using the Z-80 must use additional circuitry to remain compatible. One or two manufacturers make processor boards using the Motorola 6800 or MOS Technology 6502 processors for the Altair bus, but this is an unhappy marriage for the bus is not really well suited for these processors. Altogether, there may be as many as two dozen CPU boards for the Altair bus.

The 50-pin SS-50 bus, on the other hand, is far less popular, with only a handful of manufacturers making boards to fit it. It is ideally suited to the Motorola 6800 CPU, and is not used with other, although possibly the 6502 could be used with it. The Heath bus is presently only used by Heath with their 8080 processor.

In addition to the CPU board, a system must have some *memory*, in the form of one or more random access memory (RAM) boards. Memory generally comes in increments of 4K, or 4096 memory locations, where one K is 1024. A simple 4K memory board is available for \$75 or less. The greatest choice in memory boards is for the Altair bus,

with almost one hundred boards available from three dozen manufacturers, ranging in price from \$75 for 4K up to \$2600 for 64K.

A functioning system must have either a front panel board or a read only memory (ROM) board and can have both. They are needed to initially start the computer after power is first turned on by entering the first program, which can then be used to load following programs. The very first program to be entered must either be stored in ROM memory, and read in automatically when power is turned on or a reset button is pressed, or else a control panel with switches and indicators must be used to *load* it.

Input and output *interface* boards connect the bus to external input and output devices. Four popular types are a *video* board which provides a display on a tv monitor (a modified tv set), a *cassette* board which provides program and data storage on an ordinary cassette tape recorder, a universal *serial* interface board which can connect to a teletypewriter or CRT terminal, and a *parallel* interface which might connect to an inexpensive keyboard for program and data input.

These are not, however, the only boards available, as many manufacturers make other boards or combination boards to fit various busses. For the Altair bus, for example, there are combination cassette/serial/parallel boards available, as well as interfaces for analog inputs and outputs, color tv sets, tv cameras, disc and tape drives, digital

clocks and digital calculators, speech input and speech output devices, music synthesizers, high speed printers, telephone lines, and IBM Selectric typewriters, to name just a few.

Assembled systems as well as kits are suitable for general purpose computing as well as for more specific purposes such as control. The next category, however, is more suited for control than general computing.

■ **Single-board computers:** it is entirely possible to put all the components for a complete computer on one printed circuit board. Although a few complete systems are available on a single board (the Radio Shack and Ohio Scientific systems are really single-board systems), many of the systems in this category are much more limited, both in their total memory as well as the variety of input-output equipment.

A popular example is the KIM-1 by MOS Technology. This is a single printed circuit board having a 6502 central processor, a small amount of memory (both RAM and ROM), a small keyboard and a light emitting diode display, costing \$245.

Other computers in the same price range are the IMSAI 8048 and the Motorola MEK6800-D2 kit. The National Semiconductor SC/MP kit with its display module is about \$195. Perhaps the cheapest system in this category is the National SC/MP kit at slightly under \$100, but it requires a teleprinter or CRT terminal for input and output.

Except for the KIM-1, which can be interfaced to the Altair bus, it is very dif-

icult to expand the others. As a result, none of them is suitable for general purpose computing. On the other hand, they are superb for the enthusiast or engineer who wants to learn about microprocessors in order to improve his knowledge and possibly get a better position. Since they are so simple and limited, a good knowledge of both programming and electronics is needed to get the most out of them, and this leads to excellent learning.

All these single-board systems are suitable for control of model railroads and the like, although for most applications they will need additional memory. Most of them have facilities either on the board or on an extension board for adding additional memory to fit slightly more complex uses.

The finishing touches

Although a computer can be operated easily enough from its front panel or a small keyboard, in the long run this will be satisfactory only if it is used for control applications where it is programmed very rarely, so that it operates unattended at its control job for long periods of time. This might be true of a computer controlling a number of household gadgets such as the burglar or fire alarm, the sprinkler system, and the heating system, but it is not true of a computer being used for general computing or games. In this case some more convenient way of entering data into the computer and getting results out is needed.

Entering data and programs into the computer is the easy part. New and

used typewriter-like keyboards are available for \$35 to \$60. Radio Shack carries a complete kit for about \$50. Commercial programs are available on paper tape, cassettes, and flexible records. Paper tape readers are available for perhaps \$60 and cassette players or record players are even cheaper. Some computers have built-in interfaces for connection to these, while for others it may be a relatively inexpensive option.

Output, however, is more expensive. The least expensive is a used Baudot 5-level teleprinter, available sometimes through ham magazine ads or at ham flea markets for as little as \$25 for older models.

Plug-in tv interfaces which can display 16 lines of 32 characters across the screen of a common tv set cost as little as \$75 for some busses, but for the Altair bus the price is usually around \$175. Several companies have printers for \$250 which connect to a parallel interface board. Complete CRT terminals, which include a typewriter-like keyboard, a small tv monitor and all the circuitry to drive it, have been introduced in the past six months by Heath and Southwest Technical Products Corporation for close to \$500. However, although tv display outputs are convenient and silent, in the long run a printed output is a necessity for many uses.

Newer teleprinters using the ASCII code, still in great demand even for commercial computers, cost from \$500 used up to \$1000 new, and higher speed teleprinters such as the DECwriter or a "daisy wheel" terminal can cost as much as \$4000. For text editing applications, a printer having lower case as well as upper case letters is a must. Many hobbyists have obtained used IBM Selectric Input/Output typewriters, Dura or IteI text editing typewriters, or Flexowriters for just this application. They are available on the used market for \$300 to \$800, depending on condition and age. They also occasionally are auctioned off by the government as surplus federal property.

Talking to your computer

Although many programs are available from computer manufacturers, other hobbyists, computer stores, and computer magazines, every home computer owner eventually will want to write his own programs to do something special on his computer. Three types of computer languages are used to program home computers—machine language, assembly language, and higher-level languages such as Basic.

The fundamental computer language is *machine language*. It consists of numerical codes for each of the possible machine operations. Every computer, no matter how small, understands a machine language and can be programmed in it. Many of the single-board



computers can be programmed using only machine language, entered directly through a small numeric keyboard like that of a calculator. Unfortunately, machine language is awkward for people, since it requires great attention to detail.

The next step up is *assembly language*, where some of the drudgery required by

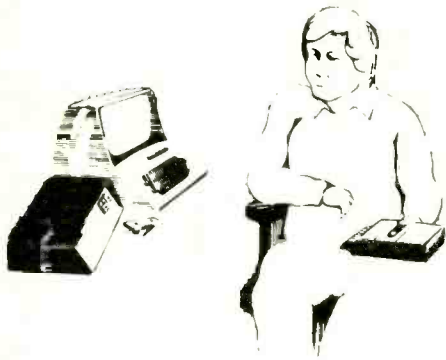

machine language is taken out of the process by a translator program (available from the manufacturer or other source of programs) which translates the assembly language program into machine language. To translate the assembly language program, however, requires at least 3 to 4K of memory; more is the program is large.

The currently most popular language for beginning users is *Basic*. Originally developed at Dartmouth College for beginners, it is still as popular today as it was with Dartmouth students some 15 years ago. Once some Basic rules are learned, it is very easy to use. A typical program—one that asks your name and then prints a reassuring message—would look like this:

```
1 PRINT "HI, WHAT'S YOUR
NAME?"
2 INPUT A$
3 PRINT "NICE TO SEE YOU, "; A$
4 END
```

A\$ is simply a symbol for storing whatever name the person types in. The computer then would print it out following the words NICE TO SEE YOU.

A *translator* is required to translate the Basic language program into machine language, and this translator needs about 4K of memory for simple programs, more for longer or more complicated ones. Basic translators are, however, easily available. Some of the systems even come with the Basic system permanently stored in a read-only memory. From there on, it's up to you.

Now that microprocessors are finding their way into test instruments, penny arcade games, home appliances, CB sets and many other industrial and consumer devices, it is a good time to learn about what they are and what they can do. And what a better way than with a home system of your own? 



Coming next month

- Russian satellites
- AM stereo
- Trunk-mount CBs
- Drunk meter
- Computer VDTs
- Ham autopatch
- Electronics schools
- 3 dozen weekender projects for spring

We're excited about our world of features, projects and product reviews. We're going to have the most colorful, most exciting, most informative electronics magazine around. Here's what we'll have each month:

- simple inexpensive contemporary construction projects using readily available parts;
- reports and evaluations of useful new gear;
- easy-to-understand instruction in basic electronics; and
- exciting accounts of the many different hobbies within electronics by hobbyists actually in those fields.

FUTURES

We've programmed a spectrum of articles for the coming months in *Modern Electronics*. Here's a short sample:

1. How a computer is different from a calculator. 2. Video games. 3. OSCAR satellites. 4. AM stereo. 5. CB frequency counters. 6. FCC strike vans. 7. How computer video display terminals work. 8. Telephone add-ons. 9. Model railroad digital controls. 10. NE555 projects. 11. How to install stereo in your van. 12. Ham autopatch and how it works. 13. Cheap-n-easy power supplies to build. 14. CB matchboxes. 15. Solar-powered gadgets. 16. Car computers in your future. 17. 55-channel marine radios. 18. Microcassette recorders. 19. How computer memories work. 20. TTL projects. 21. How to start your car in the garage from inside your warm kitchen. 22. Cure CB and ham TVI. 23. Cleaning your CB radio. 24. Battery stereo decks. 25. Unusual tools. 26. How to use a breadboard. 27. Different expert views on how to build Mel, our friendly robot. 28. Testing the Radio Shack computer. 29. Building a 60 Hz timebase. 30. Three ham QRP transmitters. 31. Model airplane electronics explained. 32. Change your calculator to a stopwatch. 33. Five ways to upgrade your CB base station. 34. Mobile telephones. 35. LED logic monitor projects. 36. What good is a tone decoder? 37. I built the Altair 880B and loved it. 38. Diode testers. 39. Solve problems with our electronic coin toss. 40. Pep up your ham, CB or SWL receiver with a preamp. 41. What's a computer motherboard? 42. WWW. 43. Carting the Heath HW-8 into the backwoods of Pennsylvania. 44. Drunk meter. 45. Digital turntables. 46. I installed the Heath H8 computer. 47. Trunkmount CBs. 48. R2D2

sounder. 49. Auto digital instruments roundup. 50. I built the OSCAR satellite. 51. CMOS projects. 52. CB repeaters. 53. Spring weekender projects. 54. Stereo add-ons. 55. Pocket scanners. 56. 8 great moments in basement workshops. 57. National Weather Service broadcasts. 58. 9 uses for SCRs. 59. Computer tape punchers explained. 60. How to SWL the RTTY signals. 61. Digital logic made simple. 62. Supermeter. 63. Mo-Fi. 64. In-dash CB roundup. 65. LED field strength meter. 66. Electronics schools for ham tickets. 67. Reel-to-reel tape decks. 68. Op-amp projects. 69. Pocket beepers. 70. Capacitance in the Handbook. 71. How the Z80 differs from an 8080. 72. I/O explained. 73. Lightwave telephones. 74. Tapes from outer space. 75. Crossword puzzles. 76. Thumb Thing. 77. Recipe card projects. 78. New gear. 79. Video recording. 80. Scanning monitors. 81. How to get started in ham radio. 82. Best shortwave receivers. 83. Test equipment. 84. Fast-scan vs. slow-scan. 85. Building your first computer system. 86. 900MHz CB. 87. Home security projects. 88. What good is a digital VOM? 89. Space satellites. 90. Tuning up your own scanner. 91. Basic radio repair. 92. Robots. 93. How boatman's radar works. 94. 10 workbench tips from the pros. 95. Stereo receivers. 96. Electronic troubleshooting made easy. 97. What can you do with 100 unmarked chips for 69c. 98. How to use a CB beam. 99. TV DXing. 100. Apartment antennas for CB/ham/SWL. 101. What's a NiCad battery? And the list goes on and on...

13 projects under \$10

A baker's dozen easy-to-build construction projects. Get parts anywhere and complete them in a weekend.

by Jeffrey A. Sandler
Contributing Editor

Just the thing to while away a long winter's evening: 13 easy, inexpensive electronics projects. Each takes a handful of parts from your local Radio Shack or the parts houses listed in the back of Modern Electronics. A soldering iron under 30 watts, some solder and the parts will put you in business.

Check out the whine tester. What could be easier? One capacitor and a speaker and you can hear the condition of the alternator in your car!

If you have been hungry to get started in amateur radio but haven't gotten around to practicing the International Morse code, build the Di-dah-dit sender.

Find out if your CB is putting out transmitter power. Set our radio-check circuit near your transceiver and see if it lights up when you transmit.

Charge three batteries at once in the triple charger and check your diodes in the tester. Kill commercials in your radio with our audio silencer.

The hearing tester will tell you just how high a frequency you can hear. And how much sound level you need to hear. The egg timer will time you...whatever.

Get a friend and play Ready, Set, Go! It'll drive you bananas. Nobody will psych out your electronics combination lock. There are 10,000 combinations possible.

By the way, our home security brain and the wailer actually can earn their keep even if they prevent only one break-in.

Radio check

1

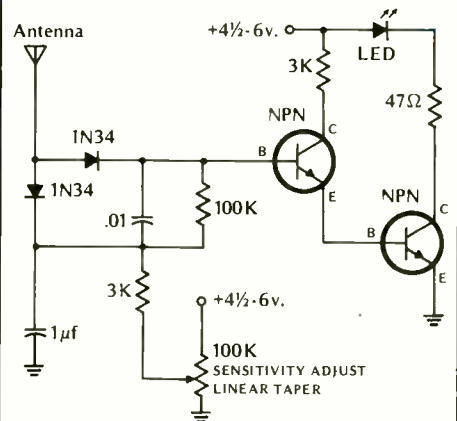

This transmission indicator is 100 times more sensitive than field strength meters at one-fifth the price. An LED lights only if the RF field is higher than you preset as the field strength level. Watch out of the corner of your eye to see if the LED is glowing as you transmit. Any small signal NPN transistors can be used. Two penlight cells provide power and will last about a year.

ME art: K&S Graphics

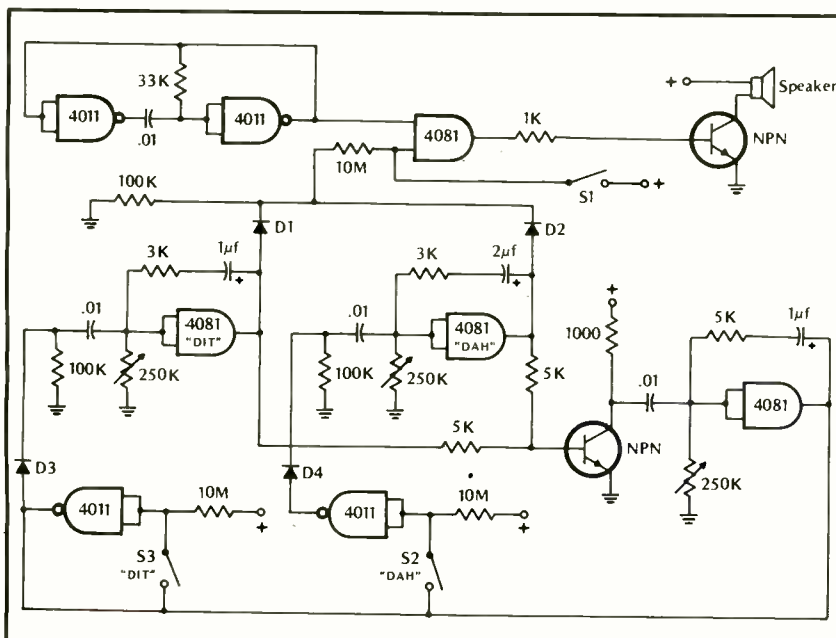

Di-dah-di sender

2

This sophisticated code practice oscillator costs pennies to build, yet has individually adjustable *dit*, *dah*, and *space* duration controls. You can use separate SPST switches for S1 and S2, but for the feel of ham radio, use a sideways-moving "paddle" key. Just connect the paddle to the 4011/4081 output line, one of the contacts to the *dit* 4011 input, and the other contact to the *dah* 4011 input. You can use any small signal NPN transistors—2N2222 and 2N3904 work well. The oscillator runs on a standard 9-volt battery, but will work on 6 volts as well.

Commercial killer

3

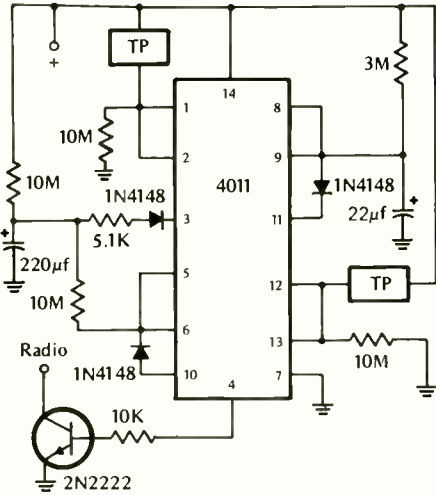

With a touch of your finger, you can turn on your radio for up to a half-hour, after which it turns itself off automatically. With a second touch, you can kill the sound for one minute—long enough to silence annoying commercials. Each touch plate, labeled "TP" in the diagram, consists of two strips of metal about 1/16th inch apart. Bridging the gap with your finger activates the circuit. When you've built the circuit, you can mount it right inside the radio case. Power it from the 9-volt radio battery. To connect it to the circuit, remove the wire presently going to the minus (-) terminal of the battery and reconnect it to the collector, marked "radio" in the diagram, of the 2N2222 transistor.

Triple charger

4

Build a charger that handles three sets of different-voltage batteries for one-third the cost of a conventional charger. With a plug-in AC adapter from your calculator and a few inexpensive parts, this circuit accurately monitors within 20 percent the rate of charge of each battery by the brightness level of pilot lamps or an LED. Any 6 to 24 volt rechargeable battery can be handled. The transistors can be any NPN types capable of handling the voltage and current of the batteries you want to charge. R1, R2, and R3 limit the current flow to the battery. Refer to our Handbook section in this issue for how to calculate resistance for a given voltage and current. R4 must be selected for the current range of the LED used.

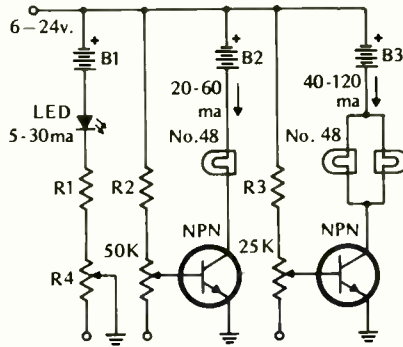

Security wailer

5

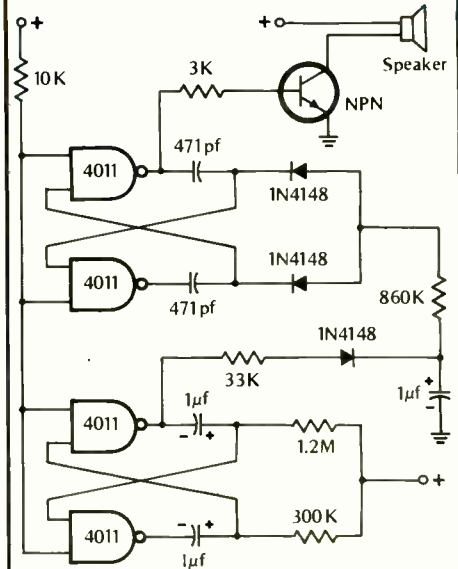

Sound off with the wail and shriek of a fire engine. The blast of sound can be varied depending on transistor and speaker selection. By varying component value, you can change the sound to suit your tastes. The rise and fall of the wail's pitch plus the percentage of change in pitch also can be adjusted.

Diode check

7

Check diodes under load with ME's diode tester. Avoid mistakes, caused by using a VOM, with this foolproof method. First, place the diode across terminals so LED is off. If this can't be done, the diode is bad. Second, press switch. If LED stays off, the diode is good. The cathode of the diode being tested is the end connected to ground. Note that sometimes "leaky" germanium diodes cause the LED to light dimly.

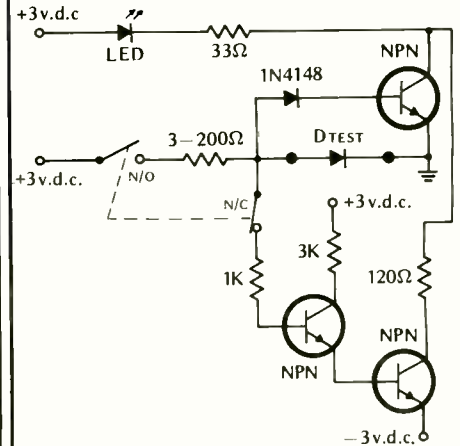

Blown-fuse alarm

6

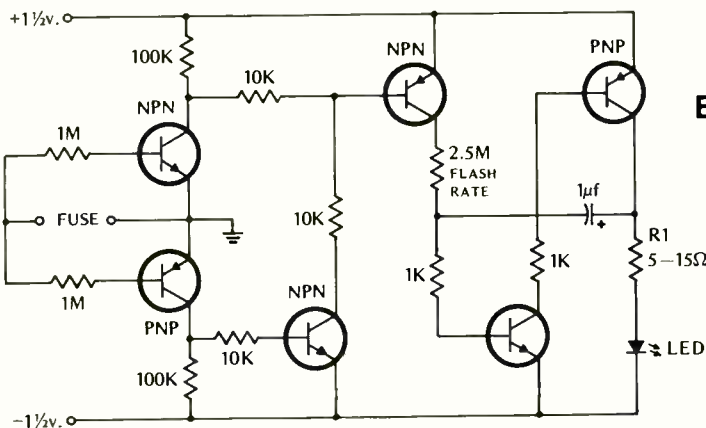

If you've ever spent an hour looking for a fault in an electronic circuit only to find the problem was a blown fuse, you'll love this handy blown-fuse alarm. Just connect it across the fuse in your circuit—the alarm does the rest. If the fuse does blow, an LED indicator, which can be mounted in any convenient location, will begin to blink. A pair of AA penlight batteries will keep the LED blinking for up to three months if you don't use the protected equipment regularly.

Any small signal NPN transistors, such as the 2N3904, and PNP transistors, such as the 2N3906, can be used. The value of R1 should be selected to provide average light intensity from the LED you use.

Egg timer

8

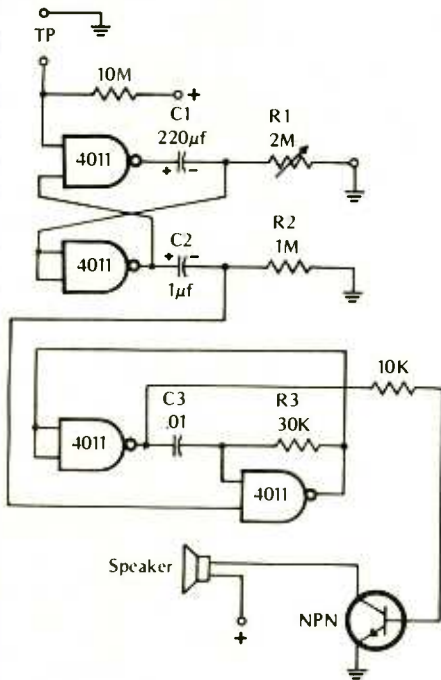

Here's a nifty egg timer that can also be used in the darkroom, or wherever you need to time periods of up to seven minutes duration. A built-in control lets you set the period you need. Then just touch the "turn-on" plate and wait. After the selected time has elapsed, an alarm will sound for a short period, then automatically turn off.

The turn-on touch plate, labeled "TP" in the diagram, is two metal strips about 1/16th-inch apart. Bridging the gap with your finger activates the timer. If you need more time range, increase R1 and/or C1. R2 and C2 determine the period of time that the alarm will sound. Increasing either will extend the time. The tone of the alarm is determined by R3 and C3. Increasing either *lowers* the tone, decreasing them *raises* the tone.

Hearing tester

9

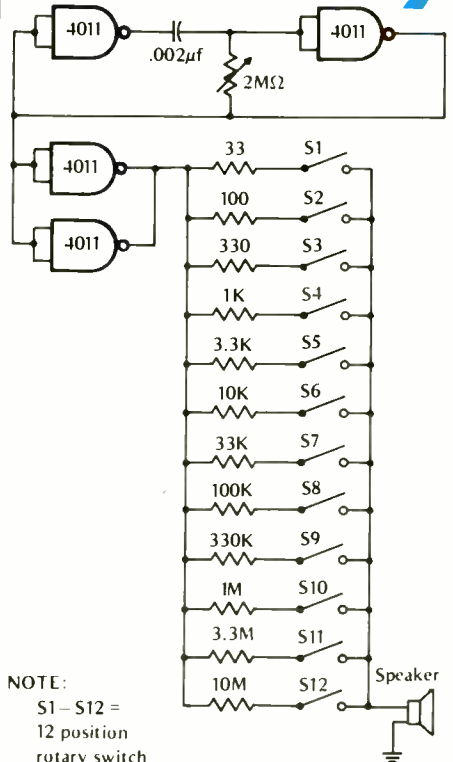

NOTE:
S1 - S12 =
12 position
rotary switch

Is your tv set turned up louder than anyone else's? Do others hear sounds you can't? You can test your hearing with this handy hearing tester. A built-in variable tone generator lets you set the frequency from about 400 Hz to 20 kHz. Then just turn the selector switch through each of 12 positions. Each switch advance reduces the sound by 10 dB. By comparing the switch position at which the sound becomes inaudible to you with the positions for others, you can get a good idea of how your hearing stacks up.

For best results, use a 100-ohm speaker. If you can't obtain a 12-position rotary switch, use 12 SPST switches. A nine-volt battery will power the tester adequately.

Ready, Set, Go!

10

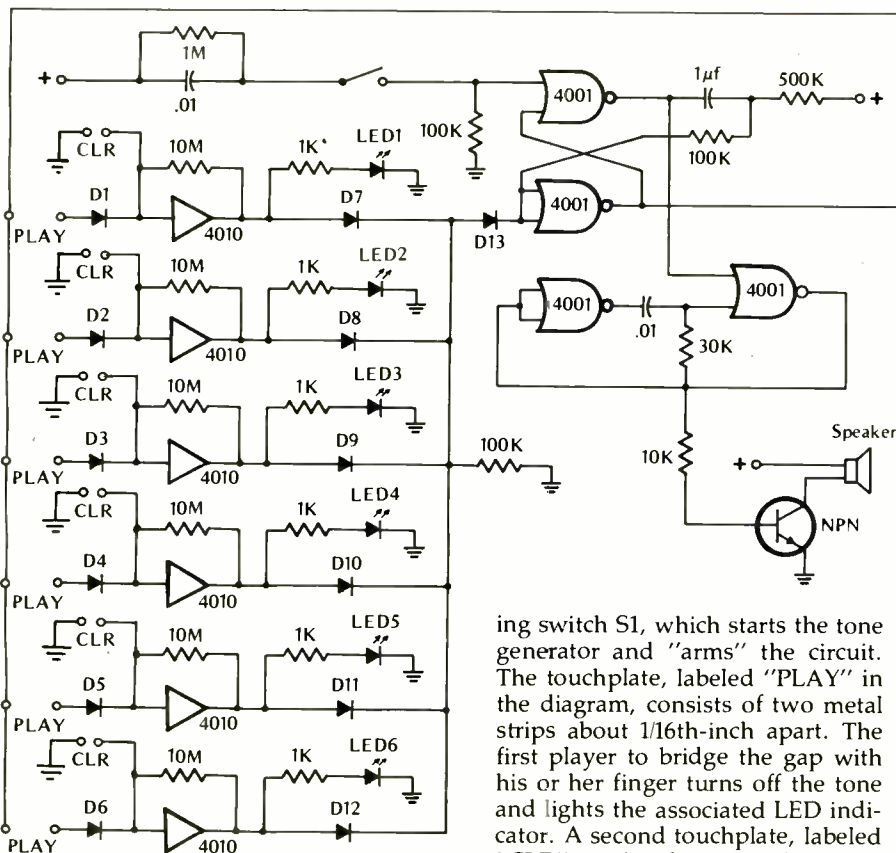

This great party and coffee table game tests players' reaction times. The fun game is activated by clos-

ing switch S1, which starts the tone generator and "arms" the circuit. The touchplate, labeled "PLAY" in the diagram, consists of two metal strips about 1/16th-inch apart. The first player to bridge the gap with his or her finger turns off the tone and lights the associated LED indicator. A second touchplate, labeled "CLR" in the diagram, clears the circuit, extinguishing the LED, when its gap is bridged by a fingertip.

Whine tester

11

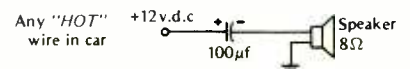

This simple under-\$1 circuit tells you if there's anything wrong with your car alternator by analyzing the whine. A clean-sounding whine means the alternator's OK. Whine with a buzz means one or more diodes burnt out. If whine frequency doesn't keep pace with engine speed, the fan belt is loose.

Home-security brain

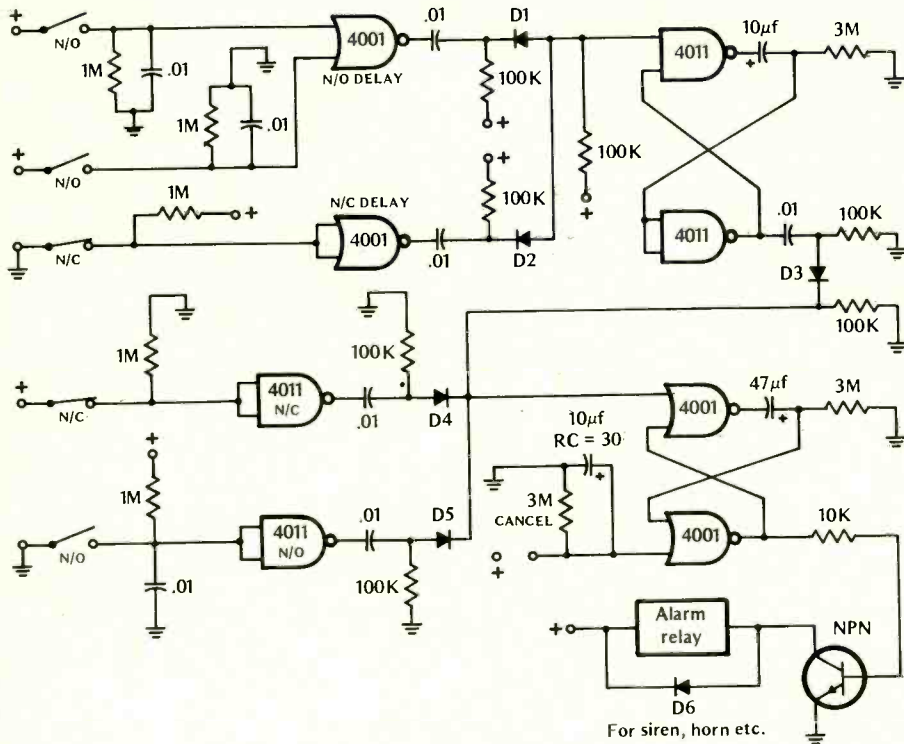

Get a loud blast of sound for your home security monitoring system for protection against forced entry by burglars. Battery powered, the unit is on duty even during power failures. Standby current drain is so low the batteries will perform for their shelf life. The circuit shown provides both normally open contacts (NO), such as fail-safe magnetic door switches, and normally closed contacts (NC), such as window tape. The two lower switches provide instantaneous operation. The three upper switches turn on the alarm after a 30-second delay, giving you time to turn off the system by closing the "cancel" switch.

If you use a reed relay to activate your alarm, a 2N2222 or 2N3904 transistor can be used. Otherwise, any NPN transistor with a current rating high enough to power the relay you use will work.

Electronic combination lock

A thief has only seven seconds to crack this 10,000 combination push-button lock. If an incorrect button is pushed, an alarm sounds and all pushbuttons stop working for two minutes. The relay built into our circuit lets you control anything from your front door lock to car ignition. A nine-volt transistor radio battery runs the circuit one year.

To operate the lock, you must close S1, S2, S3, S4, and S5 in rapid sequence. By connecting these five switch leads in a random fashion to a 10 button switch pad, you can make any sequence you want—9, 2, 5, 4, 10 for example. To further complicate things, you connect the "disable" switch leads to the remaining switches on the pad. So, if the intruder pushes 9, 2, 5, 4, 8, the lock disables so that even if he then pushes 10, it still won't open. You can use any NPN transistor with ratings high enough to power the relay you use to activate a circuit or electrically operated lock.

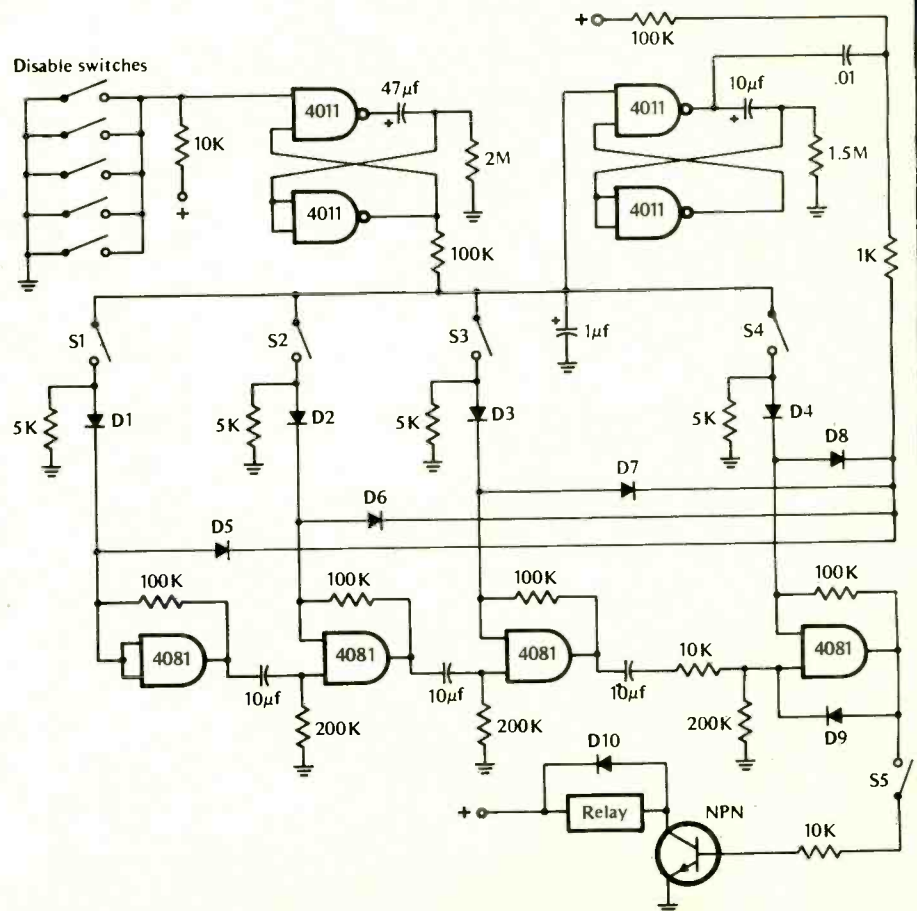

\$ 77⁷⁷



KRIS puts highway help at your fingertips...

Just pick up the mic—Kris XL 45 CB is as easy to use as a telephone! You have 40 channels to choose from, with 100% modulation and 4W maximum legal power, so you can reach out to fellow CB'ers for highway directions, weather reports, emergency help or just good conversation. And, Kris XL 45 has the features you want most: noise blanking, RF gain control, mic gain control, LED channel readout, talkback intercom. KRIS XL 45—the TALKING ROADMAP AT YOUR FINGERTIPS.

ECHO[®]
ECHO COMMUNICATIONS, INC.

/CEDARBURG, WI 53012



Toll Free: 800-558-5151

In Wisconsin 800-242-7010

CIRCLE 51 ON READER SERVICE CARD

Repeaters are the best thing that's happened in ham radio since sideband



ME art: Harold Perry

A repeater is a receiver feeding its audio into a transmitter. Signals received at the repeater site are retransmitted over the air. The advantage is to weak portable or mobile stations which need only to transmit enough power for their signals to be heard at a repeater site atop a tall building, hill or mountain. The weak signal is boosted and retransmitted over a wider area.

by Judy Curtis, WB3AIQ
Contributing Editor

The most exciting news in ham radio in 25 years is the boom in VHF and UHF repeaters. With well over 2,000 "machines" on the air, old-timers are flocking

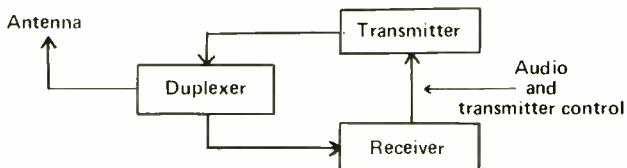

Repeaters are easy to understand. In block form: the antenna intercepts signals in the air. A duplexer allows signals to pass into the receiver without interference from the repeater's transmitter which is on the air even as the repeater is receiving signals. The repeater's receiver changes incoming radio signals into audio sounds which are fed into the repeater's transmitter. The transmitter boosts the signals and sends them out through the duplexer to the antenna and into the air.

back onto the air and newcomers are about to double our numbers.

Hams always have wanted to chat while driving cars. Some have done it, even decades ago when gear filled trunks and sapped car batteries. In the last 10 years relatively small shortwave transceivers from

Yaesu, Kenwood, Atlas, Swan and others have let us cart the high-frequency station away from home.

But these radios are bulky and frequencies in the 3-30 MHz portion of the spectrum require monster antennas and cumbersome loading coils, like tree trunks sprouting from rear bumpers.

So what are hams doing differently in 1978? Using small mobile and tiny portable VHF/UHF fm radios with antennas only a fraction the size of 3-30 MHz whips.

Transmissions in fm give hi-fi voice reproduction.

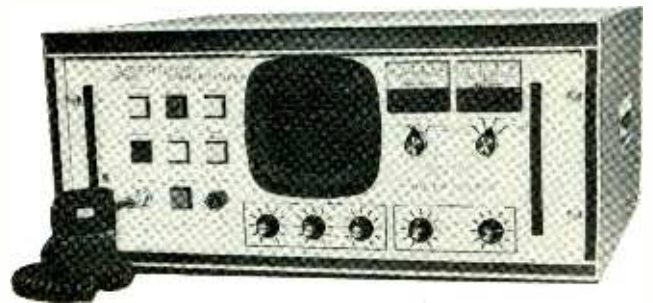

Spectrum Communications SCR-1000 is a complete under-\$1000 amateur radio VHF fm repeater in a single package. It has operating controls and metering up front in a contemporary-styled cabinet. An antenna system, with or without duplexer, is all that is needed to put this machine on the air.

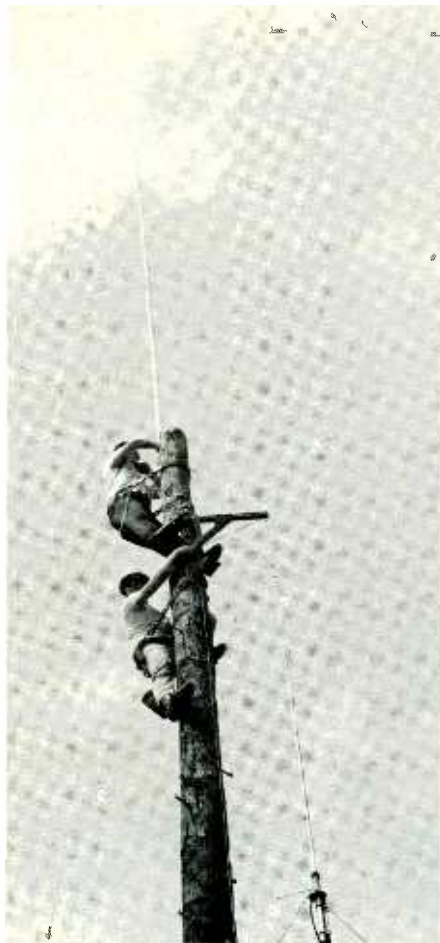

ME photo: Mary Patton

Bob and Tom Gutshall, operators of amateur radio stations W3BTX and W3BZN at Altoona, Pennsylvania, work high up a tower on the antenna of ham repeater WR3ACM on a mountain in central Pennsylvania.

Transmitter powers range from less than one watt to 30 watts of typical output power rather than the 100-1000 used on lower frequencies. Uncut quarter-wave antennas are as short as six inches. Typical antennas in use are about three feet long and boost the signal. Compare that with nine-foot no-gain antennas for lower frequencies.

There is a drawback to VHF/UHF radio. Tall buildings and mountains, like transparent window glass to shortwave signals, block or reflect VHF and UHF signals. How do we get around such roadblocks? Repeaters.

Repeaters are super-sensitive receivers and high-power transmitters placed atop hills, mountains, tall buildings and towers in flatlands. They hear weak signals from mobile and portable stations and re-transmit them out over very wide areas for others to hear.

Mini radios

I have used a tiny Wilson 1402 hand-held battery-powered portable two-watt radio in my living room to chat with friends up to 100 miles away. The secret: the 1/2-watt effective-radiated power

(ERP) from my Wilson traveled a short distance—less than 10 miles—across town to a repeater atop a high hill. My friend, miles away, was using a 30-watt base station with beam antenna pointed at the same repeater. Our conversation was pleasant and free of interference.

Hams everywhere use hand-size portables by Wilson, Motorola, Standard, Heathkit, Tempo, and others for walk-around communications: chatting, helping out with parades and walkathons, handling emergency communications and even giving tourist directions.

Names like Kenwood, Yaesu, Midland, Clegg, Lafayette, Icom and others are on miniature mobile radios slung under the dashboards of hams' cars. These sets usually put out 10 or 25 watts power.

Repeaters can be used for ragchewing (the amateur version of what CBers call ratchetjawing), emergency communications, public service work and even telephone calls.

Telephone calls

Hams in the Central Pennsylvania Repeater Association at Harrisburg, PA, installed an "autopatch" unit in a repeater they built for that area. Hams there equipped their portable and mobile radios with Touch-Tone (a Western Electric trademark for the key switches and tone generating circuitry in a Touch-Tone telephone)'pads."

A ham dials a special number through his radio, causing the repeater to hook itself into a local Bell Telephone Co. line. The amateur then transmits the seven-digit number he wishes to dial. The system is similar to "phone patch" which hams have used for years on shortwave, except that it is done automatically, at the remote repeater site, with no hams in attendance on the scene.



Joe deCourcelle, K3OBU, operates this repeater near Philadelphia. Bottom half of the cabinet is filled with duplexer.

An autopatch conversation is carried on as if the ham were at a regular telephone except that he must release his own push-to-talk button to hear the party on the other end. The ham retains full control at all times and can blank out unwanted comments from the other party.

Hams in Chicago, IL, Staten Island, NY, and other major cities have added

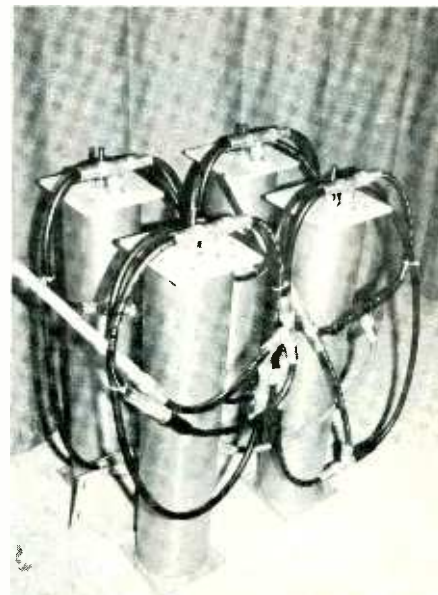

Duplexers are machined metal tubes, or "cavities," which allow use of a single antenna for transmitter and receiver. Received signal from antenna passes through to the repeater receiver but the outgoing signal from the repeater's transmitter is blocked by the duplexer from entering the receiver. Receiver receives and transmitter transmits, both at same time.

automatic dialing of the telephone company's 911 emergency police number.

At Columbus, OH, hams added an extra receiver capable of hearing National Weather Service continuous forecast broadcasts. When a correct set of audio tones is transmitted to the repeater by a ham, weather forecasts are switched on the air for use in emergencies.

The Horseshoe Radio Club of Altoona, PA, lifted a repeater to the top of Blue Knob Mountain, nearly the highest peak in the state. Before, the Pennsylvania Turnpike had poor repeater coverage through central and western Pennsylvania. Now hams can stay in touch for more than 100 miles of that superhighway with just one repeater. Altoona hams monitor the machine around the clock to relay emergencies to police.

Hams traditionally have been experimenters, and there's plenty of experimenting going on with repeaters. The friendly group running the Wheeling, WV, machine has gone as far as to build

please turn to page 85



Scanner World, USA

10- ME New Scotland Avenue Albany, New York 12208
518-436-9606

Scanner World, USA

Models May Be Mixed For Quantity Discount



BEARCAT III



REGENCY Channel Monitor



BEARCAT IV

REGENCY ACT-R-106



REGENCY ACT-E 10H/L/U



	SCANNER WORLD PRICE		Postage & Insurance Each Item
	1-5 Pieces	6 or More	
BEARCAT 210	\$239.99	\$222.99	\$2.00
BEARCAT 4 L/H/U	117.99	109.99	2.00
BEARCAT 3 H/L	98.99	94.99	2.00
BEARCAT 6 H/L	92.99	88.99	2.00
BEARCAT 12 L/H/U	122.99	117.99	2.00
BEARCAT 8 L/H/U	114.99	109.99	2.00
BEARCAT SPHL Hand Held H/L	96.99	92.99	2.00
BEARCAT SPHU Hand Held UHF	96.99	92.99	2.00
REGENCY ACT-T-16K "Touch"	239.98	222.99	2.00
REGENCY ACT-W-10HLU (Wham O)	159.99	147.99	2.00
REGENCY ACT-R-106	96.99	89.99	2.00
REGENCY ACT-C-4HLU	75.99	69.99	2.00
REGENCY ACT-R-92AP (Aircraft)	119.98	114.99	2.00
REGENCY ACT-E-10HLU	99.99	93.99	2.00

All Merchandise New in Factory Sealed Cartons. One Year Warranty.

*From SCANNER WORLD, all of the above can be yours. Call 518-436-9606 now to place a Master Charge, VISA or COD order by phone. Direct mail orders to the address below, including money order, Master Charge information, or we will ship your order COD. Catalogue free.

We ship U.P.S. ONLY

Be sure to give street address

SHIP TO:
(Use only if different from "ORDERED BY"
Please Print)

ORDERED BY: (please print)

<input type="checkbox"/> Mr. First Name M.I. Last Name <input type="checkbox"/> Mrs. <input type="checkbox"/> Miss				<input type="checkbox"/> Mr. First Name M.I. Last Name <input type="checkbox"/> Mrs. <input type="checkbox"/> Miss																												
Street or Box No.				Street or Box No. Route																												
City		State		Zip		City State Zip																										
Telephone				Telephone																												
AMOUNT ENCLOSED \$																																
<table border="1"> <thead> <tr> <th>Qty.</th> <th>Item Description</th> <th>Unit Price</th> <th>Shipping</th> <th>Total Amount</th> </tr> </thead> <tbody> <tr><td> </td><td> </td><td> </td><td> </td><td> </td></tr> <tr><td> </td><td> </td><td> </td><td> </td><td> </td></tr> <tr><td> </td><td> </td><td> </td><td> </td><td> </td></tr> <tr><td> </td><td> </td><td> </td><td> </td><td> </td></tr> </tbody> </table>								Qty.	Item Description	Unit Price	Shipping	Total Amount																				
Qty.	Item Description	Unit Price	Shipping	Total Amount																												



METHOD OF PAYMENT

- Check or Money Order
- Master Charge Visa-B/A
- C.O.D. (+.85)

Card Account Number:

Inter Bank # Above Name

Credit Card Expiration Date:

Customer Signature:

4 op-amp one-nighters

Hook-up and solder readily-available parts for one night's project fun. Make an inexpensive boat alarm, auto analyzer, temperature indicator and signal squarer.

by Jeffrey A. Sandler

boat-rustler alarm

Here's a simple alarm circuit that looks easy to defeat, but in reality isn't. The key ingredient is a resistor hidden under the dock and connected to the boat by a loop of insulated wire—ordinary lamp cord will work quite well. A potential thief, seeing the wire, will either cut it or try to short circuit it on the boat. Either

action will trigger the alarm. The hidden resistor and another with identical resistance form a voltage divider connected to the alarm input. If the wire is cut or shorted, the voltage at the alarm input will change, and the alarm will sound for about 5 minutes. The value of these resistors is not critical—anything from 20 to 100,000 ohms will work.

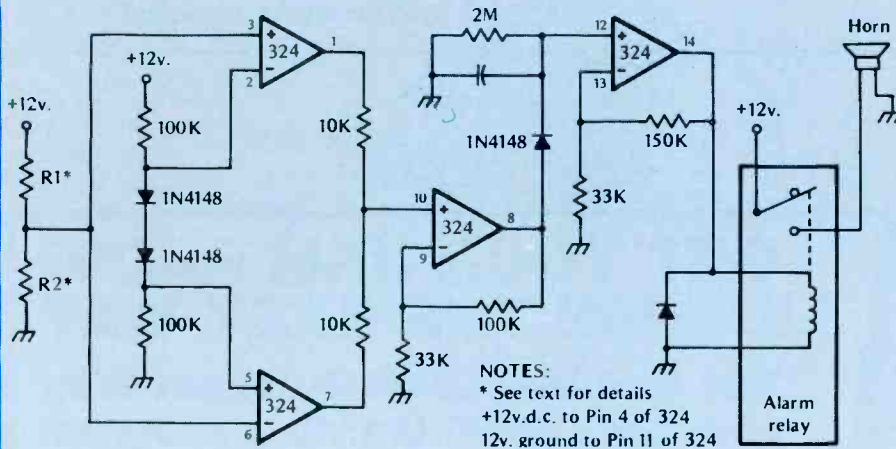

wave squarer

If you have a circuit that requires a square wave or squared pulse input, but have available only a sine wave or rounded pulse, this handy squarer circuit is just what you need. It's an updated version of the classic Schmidt Trigger, or zero crossing detector.

The output is normally zero volts. However, when the input signal crosses zero in a positive going direction, the

output jumps to near the supply voltage in about 200 nanoseconds. It remains at this voltage until the input crosses zero in the negative going direction.

By offsetting the input, an asymmetrical output can be obtained. However, if you have a sine wave with a dc offset, and want a symmetrical square wave, you can use the optional input filter. Also shown is an optional amplifier that provides a low impedance output.

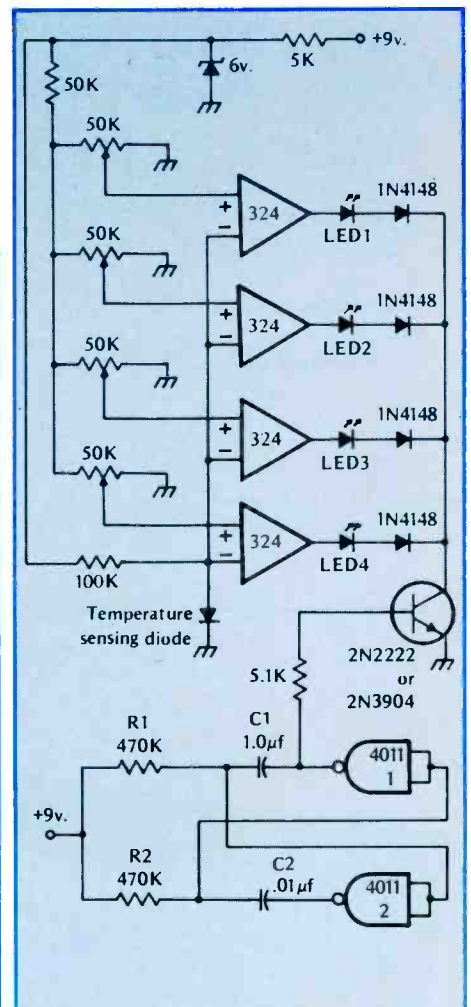
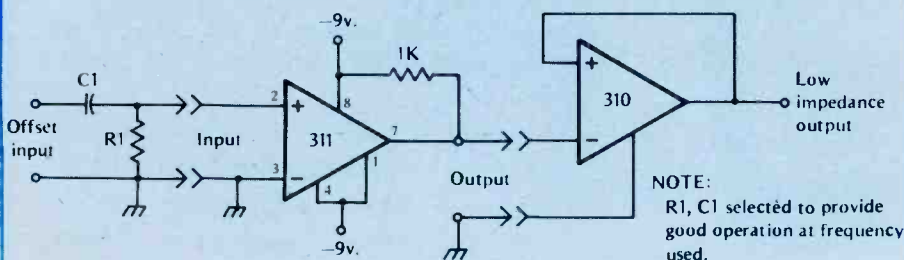

power-failure alarm

Ever come home and find all your digital clocks reading "eights" leaving you wondering how long the juice was off? Well this inexpensive circuit can give you a good idea. All you have to do is connect it to any outlet.

When the power fails, an alarm will sound and from one to four LEDs will light, depending on how long the outage lasts.

You can select the time required for each LED to light by carefully choosing the values of each R^*C^* pair. The values given here are for 1 second, 10 seconds, 100 seconds, and 500 seconds. The tone of the alarm is determined by R_1C_1 .

Current drain is quite low when the alarm is off. A single 9-volt battery should last a year.

After a power failure has occurred, you can reset the alarm by momentarily depressing the pushbutton "reset" switch.

auto analyzer

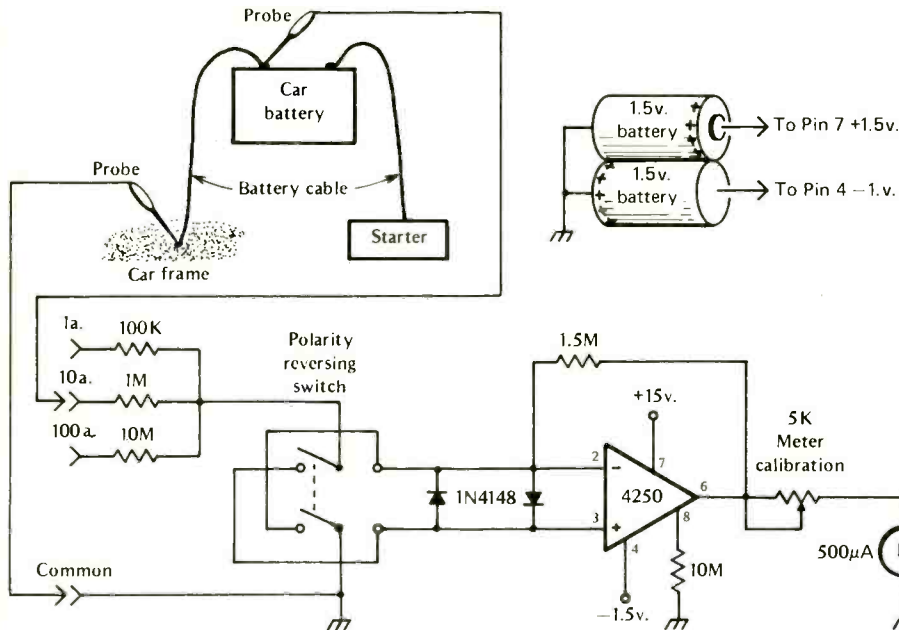

Measuring the current drain on your car's battery can be quite a problem. For one thing, it's hard to find some place in the circuit where you can break the line to connect an ammeter.

Using this handy op-amp analyzer, you can measure the current drawn by any device in your car, whether you can find the wires going to it or not. The analyzer works by measuring the very small voltage that develops across the battery cables when current flows.

The analyzer can be built as a small portable test instrument, or permanently mounted on the dashboard. However, you must insulate the instrument so that only the probes make connection to the car.

Once you've connected the probe tips to the battery cable ends (either cable will do), you'll have to calibrate the unit. To do this you must measure the current flow somewhere in your car with an accurate ammeter, then adjust the analyzer for that current reading.

GET YOUR HAM RADIO LICENSE THE EASY WAY

The Fun Way, The Quickest Way with the CQ/S9 learning program

The publishers of S9 and CQ Magazines have collaborated with Ameco to bring out the best ham radio training program ever offered. Just a few minutes a night, for just a few weeks will bring you the joys and rewards of being a fully licensed radio amateur.

This complete novice package includes a 1 hour code cassette course, a 32 page code instruction book, and an easy-to-use theory book with sample FCC exam questions.

All for just \$6.95.

The best training program on the market at the very best price. Order today.

Order from Circulation Department

Cowan Publishing Corp.

14 Vanderventer Avenue

Port Washington, N.Y. 11050

AMATEUR RADIO NOVICE CLASS THEORY COURSE



Communicate with the world through ham radio

LEARN CODE with the CODE COURSE

How To Send
How To Receive
No Previous Background Required

Ameco Publishing Corp. ABC-100
Novice Code Course
Call #1007

Complete Package... \$6.95

Send today for the
NEW WINTER '78
HEATHKIT CATALOG

FREE



The world's largest selection of fun-to-build electronic kits plus value-packed Heath-recommended assembled products. Heathkit products are world-famous for their easy step-by-step instructions, top performance and professional specifications.

**MAIL COUPON BELOW
FOR YOUR FREE COPY!**

Select from
nearly 400 unique
electronic kits for the student,
hobbyist and experimenter including:

- TEST & SERVICE INSTRUMENTS ■ PERSONAL COMPUTERS
- ELECTRONICS COURSES ■ AMATEUR RADIO
- COLOR TV ■ HI-FI COMPONENTS ■ HOME PRODUCTS
- MARINE, AUTO & AIRCRAFT ACCESSORIES

FREE

Send for your Heathkit Mail Order Catalog today! It's filled with large, clear illustrations and complete descriptions of unique products you can build and service yourself!



You can get a FREE retail catalog by redeeming this coupon in person at any of the 50 Heathkit Electronic Centers (Units of Schlumberger Products Corporation) in major markets coast-to-coast, where Heathkit products are sold, displayed, and serviced. (Retail prices on some products may be slightly higher.) Check the white pages of your telephone books for the Heathkit Electronic Center nearest you.

HEATH	
Schlumberger	
Heath Company, Dept. 378-380 Benton Harbor, Michigan 49022	
Please send me my FREE Heathkit mail order Catalog. I am not on your mailing list.	
Name _____	
Address _____	
City _____	State _____
CL-649	Zip _____

SSB/CB

Donald Duck talks farther than Ancient Modulation

Talk farther, get through worse interference with one of these pro quality single sideband rigs.

by Gerald R. Patton
Contributing Editor

Imagine a CB radio that lets you talk over longer distances, with less interference, than conventional rigs, and also comes equipped with three times as many channels. These features can be yours right now with any of the fine single sideband (SSB) CB radios currently on the market!

Sideband transmissions are more efficient than regular AM signals because all the power of the transmitter is concentrated on the intelligence portion (voice) of the signal rather than being wasted on a "carrier wave" of radio frequency (RF) energy. An AM signal is made up of this carrier wave in between

two equal but opposite intelligence-carrying signals known as sidebands. Only one of these sidebands is necessary to transmit your message through the airwaves, because each of them contains the complete voice information of the transmission. When using SSB, one sideband is eliminated completely, and the RF carrier wave is highly suppressed.

More channels, less interference

The fact that sideband signals require much less bandwidth than AM signals makes it possible to more efficiently utilize the frequencies available for CB because more channels can "fit" into the same amount of spectrum space. For example, 80 SSB channels exist within the 40 regular AM channels. Unfortunately, these sideband channels can be effectively "wiped out" by strong AM stations located on the same channels.

SSB receivers are, however, relatively immune from some other forms of interference that cause real noise problems in conventional AM receivers. One way

that interference can enter a receiver is by "riding" in on another station's RF carrier wave. With single sideband, though, the carrier wave is almost totally suppressed, thereby eliminating this possibility. Furthermore, at this time there are not nearly as many sideband stations on the air as AM stations, so that those channels reserved by gentlemen's agreement for SSB use don't exhibit the crowded conditions of many CB channels.

One negative aspect of sideband communication is the "Donald Duck" voice quality apparent on signals when the transmit and receive frequencies don't exactly match. This is the reason for having fine tuning or clarifier controls on sideband sets. The proper use of this control homes in the tuning of your receiver to the other operator's transmitter to make voices sound natural.

Sophisticated sideband

All sideband CB radios on the market offer the unique advantages of single sideband communications, but one



Cobra 132XLR rig gives 120 channels with the standard 40 available for am plus the same 40 subdivided into 40 upper and 40 lower sideband channels.

super-sophisticated unit by Texas Instruments (TI), the first to utilize microcomputer control, has even eliminated the Donald Duck syndrome. A brief tone burst code is transmitted preceding voice modulation. When using two of these radios, the tone burst is received by the other unit and causes it to immediately adjust for any frequency disparity between the sets.

TI has advanced the state of the art even further with this unit, which is available in both base and mobile configurations. All operating controls, along with a light emitting diode (LED) display, are located on a small handset. You can control squelch and volume, change channels, and select AM or upper or lower sideband modes of operation, all with this handset. The radio will advise you of the standing wave ratio (SWR), via the LED display, of the antenna you're using and will even search out a clear (or busy) channel for you.

Silence can be golden

The TI units contain a unique digital selective calling system that, when activated, allows your receiver to remain absolutely quiet regardless of other activity on the channel, until another TI radio sends a signal to you with the correct code. Millions of different possible code/channel choices are available for programming into your transceiver. Better yet, the five codes you use most often can be memorized by the microcomputer so that just one key stroke is needed to select the particular code desired.

Typical of the new breed of performance-oriented SSB transceivers is CB-5470 by Sharp Electronics.

This rig, which carries a suggested price of \$249, has an LED channel indicator which flashes when Channel 9 (the nation-wide emergency frequency) is selected.

The unit also has a noise blanker, RF gain control, and lighted mode (AM-USB-LSB) indicator.

If you haven't yet had a chance to use, or at least listen to, single sideband CB, there's a thrill in store for you. The increased range of communications possible with less interference, plus the knowledge that you are getting in on the ground floor of the future of CB, provide a welcome entry into single sideband communications for today's active, involved CB'er!



Randy Patton is an assistant director of the American Radio Relay League and an elected official in Pennsylvania.



Washington model SSB CB rig is from President Electronics.



SSB CB mobile radio, above, and base station, right, by Texas Instruments, have microcomputers built in. All controls are in the handset/microphone.

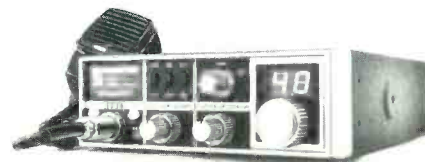

Among available SSB radios are SBE, top right; Communications Power Inc., middle right; Panasonic, lower right; Teaberry, lower left; and Sharp, upper left.

A RESISTOR IS AN ELECTRICITY SPONGE

The more water pressure in a pipe, the more water that flows. Similarly, the more volts in a circuit, the more electricity that flows. Volts are the pressure making electrons, or current, flow. The more volts of pressure, the more electrons that flow.

Electron flow, then, is current. Sometimes it's good to have a part of the circuit resist current flow. Thus, we have **resistors**. Resistors are like sponges pushed into water pipes. A sponge would soak up some water before passing it on. To get more water through, you would have to increase the pressure. Similarly, raise the voltage to pressure more current through a resistor in an electrical circuit.

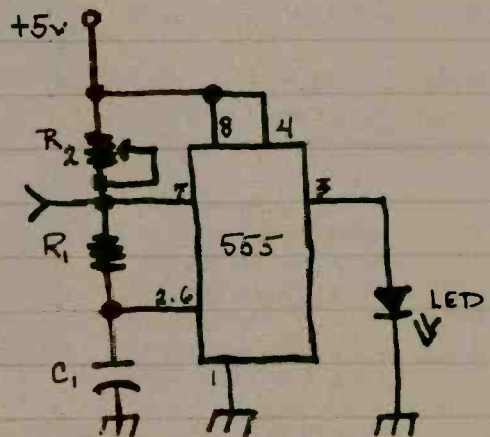

We have labels used to name the measures of electricity:

- The electromotive force or pressure in a circuit is measured in **volts**.
- Current flow is measured in amperes or **amps**, for short.
- Resistance provided in a circuit by a resistor is measured in **ohms**. We use the symbol Ω to indicate ohms.

Schematic symbols

A zig-zag line, in a circuit diagram, indicates a resistor. This schematic represents a timer which will light the LED periodically. Resistor R_1 has a fixed value. R_2 is variable, like a radio volume control. C_1 is a capacitor and 555 is an integrated circuit "chip."

A resistor is a tube with stripes and a wire coming out of each end.

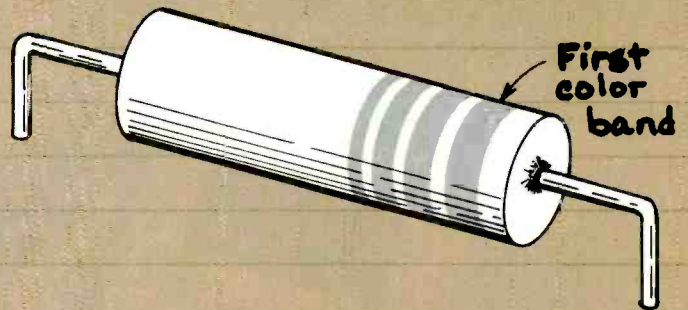

Here are the numbers matching the first two color bands on a resistor. The third band shows the number of zeros following. For example, a 4700 ohm resistor is yellow, violet and red in that order.

BROWN	1	ORANGE	3	GREEN	5	VIOLET	7	WHITE	9
RED	2	YELLOW	4	BLUE	6	GRAY	8	BLACK	0

What if none of your resistors is the right value?

Resistors are manufactured in standard values. Experimenters often stock several values. But, what if you need a 200 ohm resistor and have only two at 100 ohms?

Easy! Put the two end to end in "series" in the circuit and add their values.

$$R_1 + R_2 + R_3 + R_N = R_{total}$$

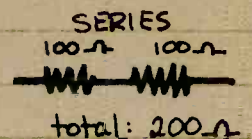

If you had placed the two 100 Ω resistors side by side in "parallel" in the circuit, the formula would be:

$$R_{total} = \frac{1}{\frac{1}{R_1} + \frac{1}{R_2} + \frac{1}{R_3} + \frac{1}{R_N}}$$

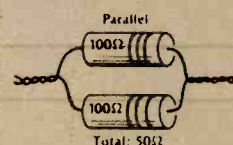
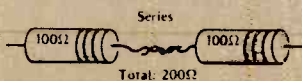
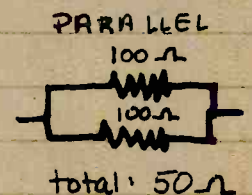

handbook



Measuring devices

- I. Ammeter measures current.
- II. Voltmeter measures emf or voltage.
- III. Ohmmeter measures resistance.

This instrument is a **volt-ohmmeter (VOM)** to measure volts, amps and ohms.

It is model 3300 by Triplet. Meters and test gear make it possible to build or repair electronic equipment.

There is a nice thing about volts, amps and ohms. They relate in a very predictable fashion. Rule of thumb for this relationship is **Ohm's law**.

Ohm's law

Here's the formula: $E = IR$

To find volts in a circuit multiply amps times ohms.

For example, 100 volts equals 2 amps times 50 ohms.

$E =$ volts

$I =$ amps

$R =$ ohms

Turn the formula around to calculate amps.

For instance, divide 100 volts by 50 ohms to compute 2 amps.

$$I = \frac{E}{R}$$

Or divide 100 volts by 2 amps to get 50 ohms.

$$R = \frac{E}{I}$$

Power: how many watts in that circuit?

The strength of an electrical circuit is its power, measured in **watts**. Power can be calculated with the formula: $P = EI$

P = watts

E = volts

I = amps

For example, 12 volts pushing 5 amps equals 60 watts.

$$12 \times 5 = 60$$

Resistors have to be physically big enough to withstand the power of the circuit they are in.

For instance, a 10 watt resistor is needed in a circuit where 5 volts and 2 amps are present.

$$P = EI. \quad 10 = 5 \times 2$$

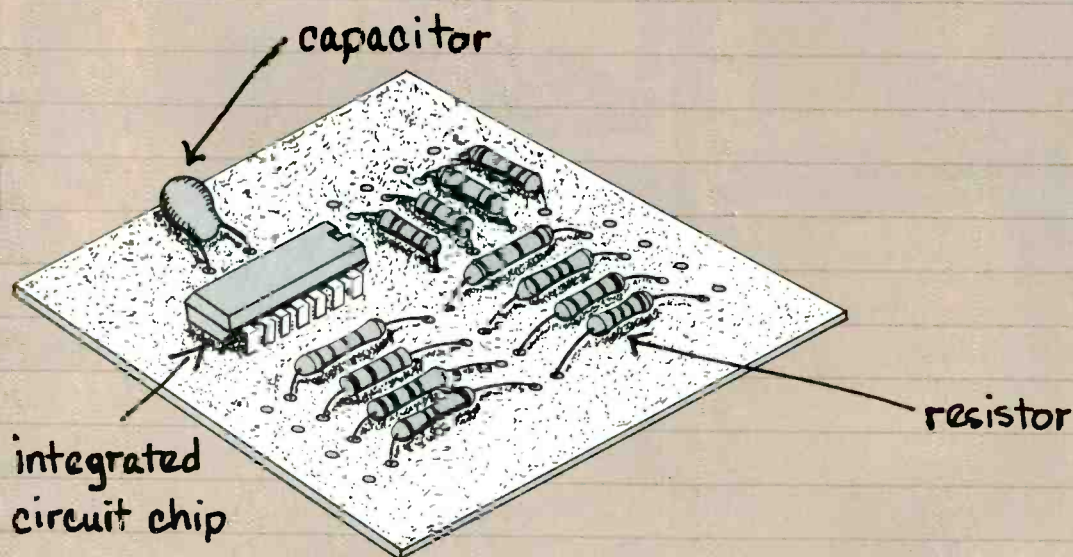

1978-style hardware usually is built of individual parts soldered to a **printed circuit board**.

Above, a PC board holds resistors, a capacitor and an IC.

Piggybanks for time

Time is money and a penny saved is a penny earned. With a videotape recorder you can amass a fortune.

by Bob Margolin



You're all set to enjoy the sporting event of the week on tv when your boss calls and asks you to have a lengthy report on his desk the next morning. It's 9 p.m. and time for the movie of the week, a film you've been waiting months to see, but the family insists on watching a special on another channel. Tomorrow is your child's birthday and you'd like to record on film those once in a lifetime happenings, but there's never enough time to set up your movie camera. What do you do?

The solution to these dilemmas is the latest, most exciting home electronics product — the home videotape recorder. Known as the HVTR, or just VTR, it is occasionally referred to as the VCR, or video cassette recorder. By any name, it is truly a marvel. With a VTR, you can record for later viewing a program being aired while you're at work or visiting a sick friend. Or, you can record the program on one channel while watching another channel. And, with an optional camera, you can make instant color and sound home movies.

Videotape recorders have been around since mid 1960s. Until recently, however, the cost and physical size of VTRs put them beyond the reach of most people. But thanks to design and production technologies spun off the space program, VTRs are becoming more affordable. Today, you can purchase a home VTR for less than \$1000 complete.

Sony, a major world producer of home tv, was the first to market a VTR specifically designed for home use — the Betamax. Introduced in Japan in the spring of 1975, the \$1300 Betamax reached the U.S. market in November, 1975. To produce a VTR at this relatively low price, Sony reduced the size of the videotape to one-half inch and created a new method of recording the program information, called the Beta format.

Encouraged by the success of the Betamax, other companies began work on home VTRs. About a year after the introduction of the Betamax, JVC (Japan Victor Company) introduced its Video Home System, or VHS format. Developed in conjunction with Matsushita, manufacturers of Panasonic products and the parent of JVC, the VHS used technology different from, and incompatible with, the Sony Beta format.

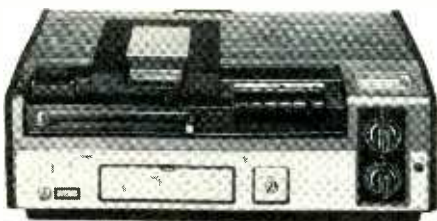

Quasar's Great Time Machine uses a simplified design that is easier and less expensive to build.

Though producing about the same picture quality as the Betamax, the VHS was physically lighter and smaller.

The great time race

The original Betamax provided one hour of playing time per cassette. This seemed adequate since most TV shows run either one-half or one full hour. JVC, however, with sporting events and full-length feature films in mind, designed the VHS to provide two full hours of playing time per cassette.

Sony countered JVC's two-hour VHS with the design of a changer that automatically would feed a second one-hour cassette into a Betamax, increasing its playing time to two hours. More recently, Sony introduced a two-hour version of the Betamax, the Beta-2 format. About this time, RCA decided to enter the home VTR market. After considering the pros and cons of both the Beta and VHS formats, it chose the VHS approach. However, RCA believed that what you really wanted was four hours of playing time per cassette. Working with RCA, the engineers at Matsushita



Sony's V Cord II uses higher tape writing speed for a sharper picture.

succeeded in modifying the VHS format to produce four-hour capability.

To differentiate between the two-hour and four-hour versions of the VHS format, VTRs are identified as being either VHS-2 or VHS-4 machines. The major difference between the two formats is the width of the recorded track on the tape. The VHS-4 track is about half the width of a VHS-2 track. Although the circuit has been modified in the VHS-4 to minimize the effect, picture quality is slightly poorer in the four-hour version than in the two.

In order to provide you with the best possible picture, all VHS-4 machines are equipped with a switch that lets you convert to the VHS-2 format when the four-hour playing time isn't required. When set for VHS-2 operation, the four-hour machines produce a videotape identical to that produced by a standard VHS-2 recorder.

Who's on first?

In selecting your VTR, you'll have to choose which format and what time capacity you want. There's the one-hour or two-hour Betamax, and two-hour or four-hour VHS format. And if these recorders don't fill the bill, there's also

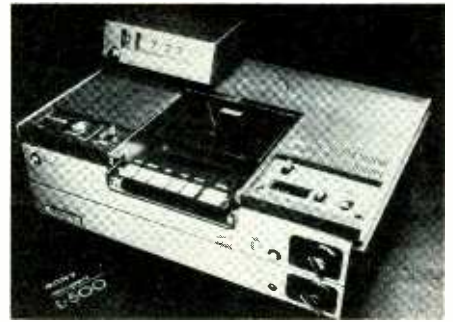

Sony was the first to market a VTR specifically designed for home use—the Betamax.

the Quasar Great Time Machine and the Sanyo V Cord II.

The Great Time Machine is based on an early VTR design of Matsushita that utilizes a single record and playback head. Because the recorder uses less complex mechanics and supporting electronics, it is less costly to build. It sports a list price of \$995.

The Sanyo V Cord II is based on Sanyo's industrial and educational VTR designs. The major advantage of the V Cord is a higher tape speed which gives you a crisper picture than the other three formats. It sells for about \$1200.

Both the Great Time Machine and the Sanyo V Cord II offer you two-hour playing time per cassette. While both have some advantages over the Beta and VHS format recorders, their biggest disadvantage is their limited distribution and potential. As "oddballs" in the VTR market, blank tapes and accessories may be hard to obtain. Servicing, however, should be readily available through the nation-wide network of Quasar and Sanyo service centers.



Your VTR becomes an instant sound home movie production center with the addition of a mic and tv camera.



The VHS-4 format, developed by Matsushita for RCA and now offered by Magnavox and other brands as well, gives you a choice of two or four hour playing time. In the long playing mode, this machine can record an entire evening's network tv programming on a single cassette.

Because of electrical and mechanical differences, a cassette designed to fit one of the VTR formats will *not* work in any of the other three. If you plan to swap tapes with a friend, you'll have to have the same format recorders. While it is too early to tell, it seems the market will be divided roughly in half between the Beta and the VHS format, with the Great Time Machine and the Sanyo V Cord running far behind.

Since you'll want to save some programs for later viewing, you'll need to buy more than one blank cassette. The prices for cassettes run about the same for all four formats — one-half hour cassettes about \$12 each, one-hour cassettes about \$15, and two-hour cassettes about \$20.

The quality of the picture you get on your tv set depends on how well aligned it is. If it is in tip-top condition, the pic-

ture you get from your VTR will seem slightly out of focus when compared to an off-the-air picture. Even the Sanyo V Cord's picture will seem a little soft. However, if your tv is in average condition, you'll never notice the difference between taped and off-the-air programming.

What about picture quality?

If you're a perfectionist who insists on the very best, you can get razor sharp pictures from another kind of home VTR — the three-quarter-inch recorder. The three-quarter inch format has been in use for about 15 years in commercial applications. With the success of the home VTR, several manufacturers such as NEC (Nippon Electric Company), JVC, Matsushita, and Sony, have added the features you need to their professional three-quarter-inch recorders. The result is a somewhat larger, heavier VTR that looks like a standard home recorder, but gives you professional performance.

As you might expect, this added performance is going to cost you. The home type three-quarter-inch recorder prices start at about \$2000. And the blank cassettes will cost more, too — about 60 percent more. But if you want the best, the three-quarter-inch VTR is worth the price.

Lights, camera, action!

All VTRs are sold ready to record and playback tv programs. But, with the

Speed counts

Take a peek inside a typical videotape recorder and see how the tape transport, playback and record heads work.

If you've ever dabbled with audio recording, you know that most reel-to-reel tape recorders can provide a smooth response up to 15,000 Hz, and many to 20,000 Hz. But have you ever wondered why even the best cassette recorders can only get up to 12,000 Hz or so?

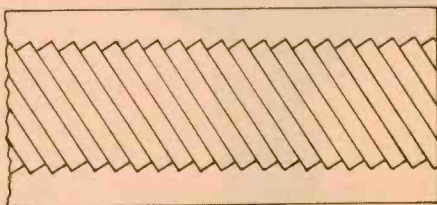

An overlapping track pattern and rotating record/playback head provide tape writing speeds of more than 20 inches per second.

The answer is speed. All other things being equal, the faster the tape travels across the recording head, the higher the frequency that can be recorded. How, then, can several megahertz of video signal be recorded on a tape moving at about the same apparent speed as it does in a standard portable cassette recorder?

This feat is accomplished by passing the tape across a recording head that is moving at a very high speed. The speed

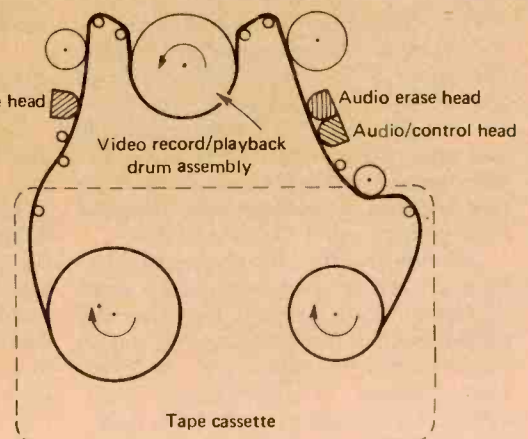

at which the signal is recorded, the tape *writing* speed, is the net speed of the rotating head and tape motion. You're probably asking yourself how the recording head can move in any direction. It can because it's mounted in a rotating drum assembly.

Overlapping pattern

The head assembly is designed to record at an angle across the surface of the tape in an overlapping pattern. By over-



The tape controls on some VTRs such as the Sony Betamax (top) are exactly the same as those on your portable cassette recorder. Others such as the JVC (bottom) have added pause and audio dubbing pushbutton keys.

addition of a \$300 tv camera, you're ready to make instant black and white home movies. Add an inexpensive microphone and you have sound on film.

Color is an expensive proposition. Until recently, color cameras ran well over \$2000. Today, you can get a good color camera from JVC for only \$1500. While this may seem high, you can pay for it with the savings in film and processing costs.

The real advantage of using your VTR to make home movies is that you can see what you've shot in the time it takes

lapping, much more information can be recorded per inch of tape than otherwise possible. In the JVC VHS-2 format, for

example, more than six times as much! Because of the overlap and the rotating head, the effective writing speed in the

to rewind the tape. If you're not happy with it, shoot it again. And when something you've shot is no longer of interest, you can reuse the tape.

If you buy a VTR, it's most likely because you want to record tv programs off the air. But, soon you'll be able to

Beta format videotape

Sanyo Betacord*

Sears Betavision*

Sony Betamax

2-hour deck, \$1300. Cassette changer and b&w camera*

Toshiba

2-hour deck; \$1300.
IK-12 color camera, \$1700.

Zenith

2-hour deck, \$1300. 25 inch tv-VTR console, \$2500. B&w camera*

The others

Sanyo V Cord II

2-hour deck, \$1050.

Quasar Great Time Machine

2-hour deck, \$995. B&w camera with built-in mic*

VHS videotape

Curtis Mathes*

4-hour, tv-VTR console

GTE Sylvania*

Hitachi*

JVC Vidstar

2-hour deck, \$1280. B&w camera, \$395.
Color camera, \$1500.

Magnavox

4-hour deck, \$1075. B&w camera*

MGA*

Panasonic

4-hour deck, \$1095. B&w and color cameras available from \$395 to \$4000.

RCA Selectavision

4-hour deck, \$995.

Sharp*

*Price and product information not available.

buy, rent, or even borrow from your local library, pre-recorded tapes. As this "software" becomes available, you'll have access to a much wider variety of program material than you can get off the air, including uncut feature films and sporting events. 

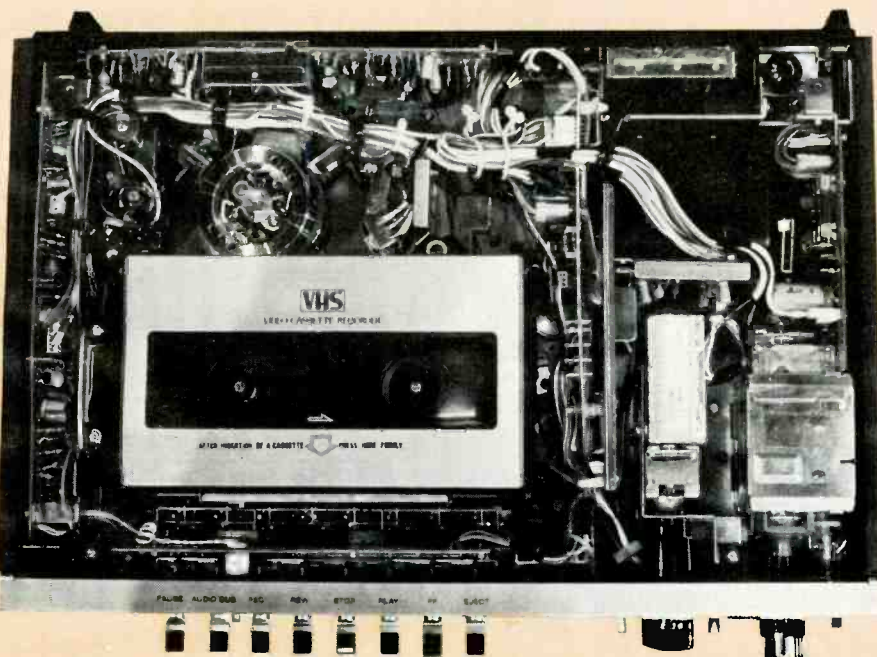

VHS-2 format is 23.2 inches per second.

Another operating characteristic of VTRs that you won't find on your portable cassette recorder is the tape path. In your portable, the tape remains within the cassette case, traveling from one internal reel to the other across one exposed side. The tape in a VTR cassette, however, is pulled out of the case to travel through the interior of the VTR itself. In some respects, it's similar to a cassette-loaded movie projector, with the tape following a complicated path through a series of rollers.

Although the path is much more complex, the operation is similar to your portable recorder. First, the tape is passed over an erase head that removes the previously recorded video program. The tape then passes over the rotating record/playback head assembly where the video is recorded, and stationary erase and record/playback heads where the sound and control signals are recorded. Because the frequency response required for recording these signals is so low, a conventional technique is used, identical to that used in your portable cassette recorder.—Bob Margolin



Eavesdrop on the world

From Iran to Italy, Burma to Brazil, there's a world of instant news, exotic entertainment and mystery signals to be heard in the shortwave segment of the radio spectrum. A new breed of pro quality communications receivers let you in on all the action with the best armchair copy yet.

by Anthony R. Curtis
Modern Electronics' Editor

The glare from a gooseneck lamp pushes a shadow from your pencil as you stare at the dimly-lit dial on your shortwave receiver, headphones cocked as you work to hear through a pile up of megawatt international broadcasters. Underneath booming signals from the likes of Moscow, London and The Netherlands, is the pirate voice of Arab Syria attacking the national regime. It's in there, you can almost hear it. And you need it for your log of stations heard on shortwave!

Around the world, thousands of listeners everyday twist radio dials in search of the rare and elusive DX radio broadcaster's signal. Shortwave listeners man monitoring posts in attics, basements, garages, dens as radio signals from four corners of the Earth descend their antenna wires.

Exotic music from the Orient, precise news from London, ham radio operators helping out in an earthquake, even Cbers talking across your hometown.

Now you can eavesdrop on radio signals, secret as well as public, more easily than ever before.

There's a new breed of general-coverage radio receiver being used by SWLs (shortwave listeners) around the world. The new sets, costing \$150-\$350, are as well-built and sensitive as the \$2500 professional rigs of the '60s.

Names like Yaesu, Kenwood, Drake, Heathkit and



Yaesu FRG-7

McKay Dymek have a familiar ring in today's SWL listening post where sets by these manufacturers pick up weaker signals, separate interfering stations, and have more features than many of yesterday's most expensive receivers.

Wet noodle

The new radios go beyond the \$25 multiband portables which hear only the giants of international shortwave broadcasting. In fact, it takes little more than a wet noodle to pick up the millions of watts transmitted by Radio Moscow, Voice of America, or the British Broadcasting Corp. (BBC).

The new batch of professional communications receivers offered to hobby listeners are far more sensitive, selective and convenient to use:

- More sensitive means they can hear Afghanistan, Peking or the 50 African nations now transmitting music, news, comment, sports and other forms of shortwave listening excitement.

- More selective means you can tune in weak signals buried on the dial between Radio Cairo, All India Radio, Radio Japan or the Voice of Vietnam.

- The new sets are convenient with more controls up front, finer tuning knobs and well-marked front panels.

Radio Shack, Drake, Yaesu, Kenwood and Dymek all tune continuously from the bottom end of the U.S. am broadcast band at 550 kilohertz (kHz) up to the top end of the shortwaves at 30 megahertz (MHz).

In addition, the Radio Shack covers 150-400 kHz. Kenwood's R-300 covers 170-410 kHz and the Dymek hears signals from 50 kHz on up.

Needs only a skyhook

All you need to make these new sets work is an antenna, and many come with a simple beginner's whip or wire. One simple antenna you can make yourself is the dipole described with this article. Hang a wire out the window to the nearest tree. Or even stretch a small-diameter hidden wire under your living room rug.

In evaluating four of the best of the new breed, I listened to hams chatting around the world, to propaganda from Albania, and to radioteletype (RTTY) carrying news stories to tickers in far corners of the globe.

I tested the FRG-7 from Yaesu Electronics, which lists at \$299 and is sold in some stores at \$269; the SSR-1 from R.L. Drake Co., which lists at \$350 and sells in one store at \$245; the DX-160 available at 6000 Radio Shack stores in North America at \$159; and the Heathkit HR-1680 from Heath Co. at \$199.

The excellent Yaesu FRG-7 also is available from Sears, Roebuck and Co. (catalog number 61A3638C) as well as in super-fine SWL tune from Gilfer Associates.

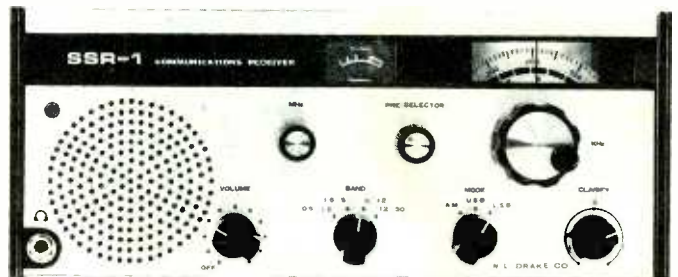

Drake SSR-1

Where to search for exotic signals

Tune across these frequencies in the shortwave portion of the radio spectrum. International broadcasters, amateur radio operators, CBers, all sorts of unique transmissions can be heard.

International broadcasting to SWLs

120-meter band	2.300-2.500 MHz
90-meter band	3.200-3.400 MHz
75-meter band	3.900-4.000 MHz
60-meter band	4.750-5.060 MHz
49-meter band	5.950-6.200 MHz
41-meter band	7.100-7.300 MHz
31-meter band	9.500-9.725 MHz
25-meter band	11.700-11.975 MHz
19-meter band	15.100-15.450 MHz

16-meter band
13-meter band
11-meter band

The *World Radio TV Handbook* by Jens Frost of Denmark, distributed by Billboard Books (\$10.95), 1515 Broadway, New York, NY 10036, is a popular guide to the international broadcasting stations and their frequencies.

U.S. amateur radio ham bands

160-meter band	1.800-2.000 MHz
80-meter band	3.500-4.000 MHz
40-meter band	7.000-7.300 MHz
20-meter band	14.000-14.350 MHz
15-meter band	21.000-21.450 MHz
10-meter band	28.000-29.700 MHz

17.700-17.900MHz
21.450-21.750 MHz
25.600-26.100 MHz

U.S. amateurs have additional frequencies in the VHF, UHF and microwave portions of the radio spectrum.

U.S. CB Citizens Band

Channels 1-40 26.965-27.405 MHz

Time signals

WWV, Colorado	2.500 MHz
WWVH, Hawaii	5.000 MHz
	10.000MHz
	15.000 MHz
CHU, Canada	3.330 MHz
	7.335 MHz
RAT, Moscow, USSR	5.000 MHz
BVP, Shanghai, China	9.368 MHz
JJY, Japan	10.000 MHz



Radio Shack Realistic DX-160

The Kenwood R-300 is being sold by one store at \$239. The Dymek is \$900.

Tuning capacitors

The Drake and Yaesu rigs use an ultramodern *synthesizer* circuit to determine what frequency the receivers are tuned to. Radio Shack uses conventional tuning capacitors but adds dial markings so you can tune very quickly to an international broadcasting portion of the radio spectrum or to a ham band. That may make the DX-160 a bit easier for an SWL newcomer to find signals of interest.

Radio Shack, Yaesu and Kenwood have noise limiters to dampen static and car-ignition interference. And the Radio Shack has an automatic volume control (AVC) switch so you can select the steadiest signal.

Yaesu and Drake provide attenuator switches to cut



Kenwood R-300

down signal strength from overpowering local stations. These are useful when local am broadcasters overdrive your receiver or when your CB neighbor transmits on a channel next to one you happen to be monitoring.

Radio Shack and Kenwood use an RF gain control, rather than an attenuator, giving you a larger range of control.

Channel 9

You can tune smoothly and continuously from 26.960 to 27.405 MHz (CB channels 1-40) with these receivers, even hearing signals between channels. You might operate your CB transceiver on your favorite local channel, for instance, while using a shortwave receiver to monitor emergency channel 9.

The Yaesu, Drake, Radio Shack and Kenwood all operate from either 110-volt ac house power or the 12-

volt dc battery in your car or boat. Yaesu, Drake and Kenwood have space inside for packs of D batteries. Batteries left inside, if house electricity fails, automatically keep the sets functioning.

Ham-band only

What of the Heathkit HR-1680? It's a special receiver covering only the shortwave ham bands. The advantage is better sensitivity, selectivity and convenience on those particular frequencies.

Log of Monitor Station

Receiver(s) _____

Antenna(s) _____

Abbreviations	QRP	QRM	QRN	QSO	QTH	QTR	QTX	QZ	
QRP	very low power	QRM	interference	QSO	contact	QTR	transmission	QZ	silence
QRM	radio interference	QRN	atmospheric noise	QTH	location	QTX	transmission	QZ	silence
QSO	contact	QTH	location	QTR	transmission	QTX	transmission	QZ	silence
QTH	location	QTR	transmission	QTX	transmission	QZ	silence		
QTR	transmission	QTX	transmission	QZ	silence				
QTX	transmission	QZ	silence						
QZ	silence								

DATE	TIME	FREQ/DIAL	STATION HEARD	LANG	S	I	N	F	O	TRANSMISSION	REMARKS	NEW FREQ	NEW ST	LEFT SENT

From _____

To Radio Station _____

I Am Pleased To Report Reception

Your Verification (by card or letter) Would Be Much Appreciated

ON _____, 197__ ON OR ABOUT _____ KILOHERTZ

Time	Time (GMT)	Program/Transmission	S	I	N	F	O

YOU HAVE (HAVE NO) INTERFERENCE ON THE FREQUENCY. IF ANY, INTERFERENCE IS ON A _____

HIGHER (LOWER) (SAME) FREQUENCY FROM A (BROADCASTER) (RADIOTELEPHONE) (CW) (FSK)

STATION RECEIVING CONDITIONS WERE (GOOD) (POOR) (UNUSUAL) (AVERAGE)

MY RECEIVER IS A _____

MY ANTENNA IS A _____

REMARKS _____

Signal Strength	Interference	Atmospheric Noise	Fading	Overall Report
5 Excellent	1 None	1 None	1 None	5 Excellent
4 Good	2 Slight	2 Slight	2 Slight	4 Good
3 Fair	3 Moderate	3 Moderate	3 Moderate	3 Fair
2 Poor	4 Severe	4 Severe	4 Severe	2 Poor
1 Barely Audible	5 Extreme	5 Extreme	5 Extreme	1 Barely Audible

Important accessories in any shortwave-listening post are log-book, top, and reception report form, bottom above. Log has spaces where you record date, time, frequency, station heard, signal report and other key data. You fill in the blanks on the reception report and send it to the station you heard. If you are in luck, the station will send you back a QSL card confirming your reception. Pads of both forms are available at \$2.50 each from Gilfer Associates, Box 239, Park Ridge, NJ 07656.

A disadvantage is no tuning outside of five 500 kHz-wide bands.

No tuning outside those bands doesn't prevent you from serious SWL DXing. I hooked the audio coming out of the HR-1680's earphone jack into a Hal Communications Corp. ST-6000 RTTY converter and received excellent copy of radioteletype from around

the world on my old surplus Teletype model 19.

How do the new sets look? They have a blend of classic communications receiver design and modern high-style appearance. They would look great in your attic, basement, garage or bedroom listening post. But they'll also tuck away nicely in the family room. Boat anchors they're not!



How to build your own dipole antenna

Here's how to make a top-notch *dipole* antenna for any international broadcaster, ham, CB or other frequency:

Frequency

Determine the frequency you wish to hear. For example, if you would like to listen to the international broadcasting stations in the 31-meter band, note their frequencies range from 9.500-9.725 MHz in the radio spectrum. You'll want to tune across the entire 31-meter band so cut the antenna for the middle of the band: about 9.615 MHz.

Wavelength

Translate the frequency into wavelength. That is, change 9.615 MHz into an exact wavelength in meters. To do that, divide 300 by the frequency in MHz. Dividing 300 by 9.615 gives 31.2 meters, the exact wavelength for the specific frequency.

Half-wave dipoles

The dipole antenna is a *half-wave* antenna. Its overall length is five percent less than one-half of the wavelength of the specific frequency for which you are cutting the antenna. In this example, the wavelength for 9.615 MHz is 31.2 meters. Half of 31.2 meters is 15.6 meters. The total length of the dipole will be 15.6 meters less five percent end-to-end. That's 14.82 meters.

Non metric

If you're not into metric numbers yet, you'll want to convert 14.82 meters to inches and feet. One way is to recall that there are 39.37 inches in one meter. Multiplying 14.82 meters by 39.37 shows there are 583.46 inches in overall length to our dipole. With 12 inches in a foot, 583.46 inches equals 48.62 feet. That's 48 feet 7 inches approximately. So, the total length, end to end, of our dipole antenna will be 48 feet 7 inches.

Cutting antennas

A dipole antenna is a length of wire, any wire of any size strong enough to hold itself between a tree and your house, between two poles, or between two supports of one sort or another. The length of wire is cut exactly in the middle and a lead-in wire is attached at that center point. If our wire is 48 feet 7 inches long, where is the center point? Half of 48 feet 7 inches is 24 feet 4 inches. The dipole wire is cut exactly 24 feet 4 inches from either end.

Insulators

The ends of the dipole antenna and the two halves of the wire must be insulated so no electrical connection is made between them and any other object. An insulator of porcelain, plastic or rubber (Radio Shack catalog number 270-1518 is a package of two insulators for 59¢) is inserted between the two halves and at the ends. Wire can be

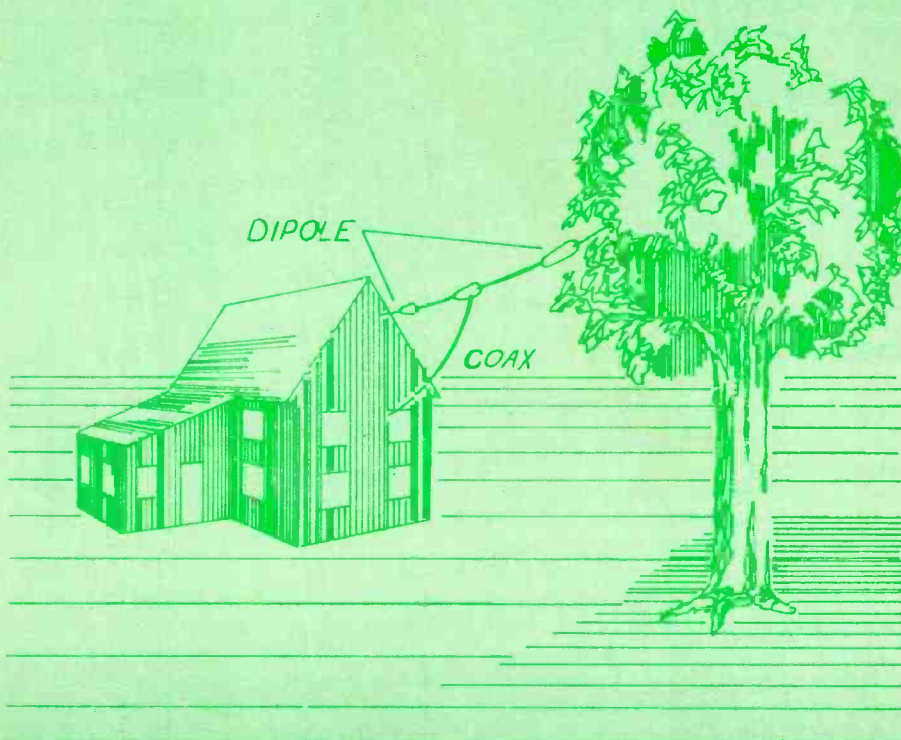

ME art: Tom Batchler

used to support the antenna wire (Radio Shack catalog number 278-1325 or similar) but it must be insulated from the antenna.

Lead-in wire

Coaxial cable of either 50-ohm or 75-ohm (Radio Shack catalog number 278-1326 or 278-1327 or similar) can be used. They are sizes RG-58/U and RG-59/U. Larger, more expensive RG-8/U is more efficient but not necessary at shortwave frequencies. Coax has a center conductor surrounded by an outer braid of wire. Connect one side of the antenna to the braid and the other side to the coax center conductor. Make sure the connection is firm mechanically and sure electrically. Solder the joints.

At the receiver

Hang the dipole as high as possible off the ground. It will work inside an apartment under a rug or taped to the walls. But, outside will be better. Stringing the wire between two trees at a height above 50 feet would be ideal. Run the coax away from the dipole at a right angle and into your

shortwave-listening shack. Attach the center conductor of the coax there to the antenna terminal on your receiver. Connect the coax braid to the ground post on your set.

Wide band

The dipole will work most efficiently when your receiver is tuned to 9.615 MHz. It will, however, work well across the entire 31-meter band. Technically, it will be less efficient when your receiver is tuned to 9.500 or 9.725 MHz, but you won't be able to tell the difference.

Other bands

Here are some wire lengths for other international broadcasting shortwave bands:

11-meter band	17'
13-meter band	21'9"
16-meter band	26'3"
19-meter band	30'6"
25-meter band	40'
31-meter band	48'7"
41-meter band	55'
49-meter band	77'
60-meter band	107'6"

signal injector

If you ever get into the repair of radios, one thing you'll need is a good signal injector. This handy gadget lets you put an i-f or rf signal into the circuit at any point you choose. With an injector, you can work from the output end of the circuit back towards the input. When the output signal disappears, you've found the bad stage in the circuit.

The injector shown here uses a single 4011 CMOS chip powered by a 9-volt transistor battery to produce a square wave. The frequency is determined by the RC time constant of R_1C_1 . Though the upper limit for this circuit is about 1 MHz, the harmonic content of the square wave should provide signals well into the rf range.

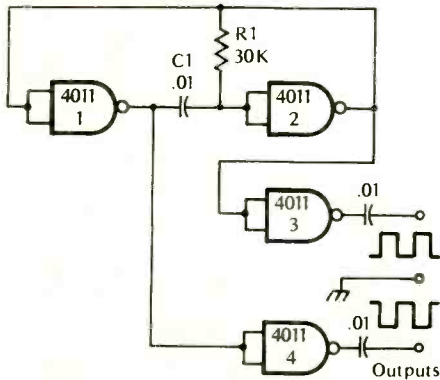

low-volts alarm

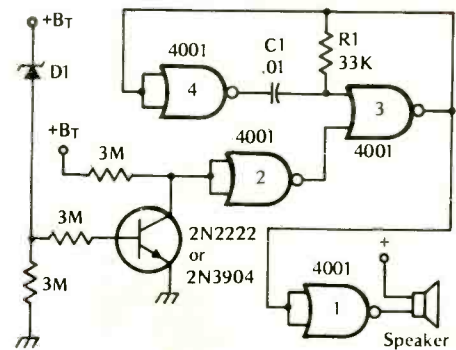

Here's an inexpensive dc supply voltage monitor that sounds a warning when the voltage falls below a preset value. It's ideal for keeping track of your rechargeable batteries since it draws only a few microamperes when not sounding.

The voltage at which the alarm sounds is determined by the zener diode, D_1 . When the voltage falls below the zener voltage, the alarm sounds. The alarm tone is determined by the RC time constant of R_1C_1 .

ME art: K&S Graphics

battery backup

If you have a circuit powered by a small dc supply you'd like to protect against power failure, here's an automatic battery backup system that's just the thing.

While the power supply is working, the battery is isolated from the circuit. However, when power fails, the battery is instantaneously connected into the circuit. There's hardly a flicker in the voltage during the change-over.

The power supply circuit shown here in light line is meant only to represent the typical supply. Yours may be different. The back-up circuit is shown in heavy line. The back-up battery must

NOTE:
* $R_1 = \frac{15 \times E_{OUT} \text{ (POWER SUPPLY)}}{I_{OUT MAX.} \text{ (POWER SUPPLY)}}$

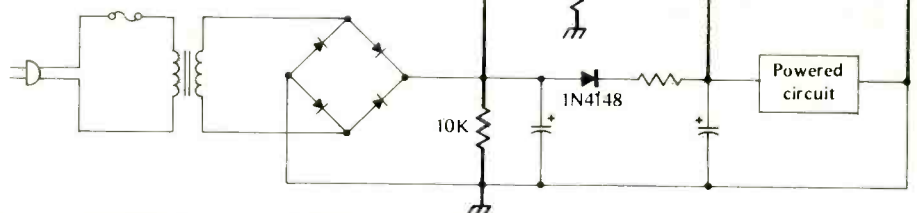

provide the same voltage and current as your supply. Q_1 can be any small-signal PNP transistor, such as a 2N3906. Q_2

should be a PNP power transistor rated to handle at least the power used in the circuit being protected.

tv killer

If you'd like an easy and inexpensive way to kill tv sound during commercials, try this handy flashlight-actuated remote control.

Shining your flashlight on the "cut sound" photocell for an instant kills the sound for a time period equal to the RC time constant of resistor R_1 and capacitor C_1 . After expiration of this time period, the sound is automatically restored.

If you hold your flashlight beam on the cut-sound photocell for several seconds, the sound will be killed for a longer time period, determined by R_2 and C_2 . You can restore the sound before the built-in time period has elapsed by shining your flashlight on the "cancel" photocell.

Because the background light varies from one home to another you'll have to tailor the photocell sensitivity to your specific environment. You can do this by covering part of the photocell with black tape so that the unit does not

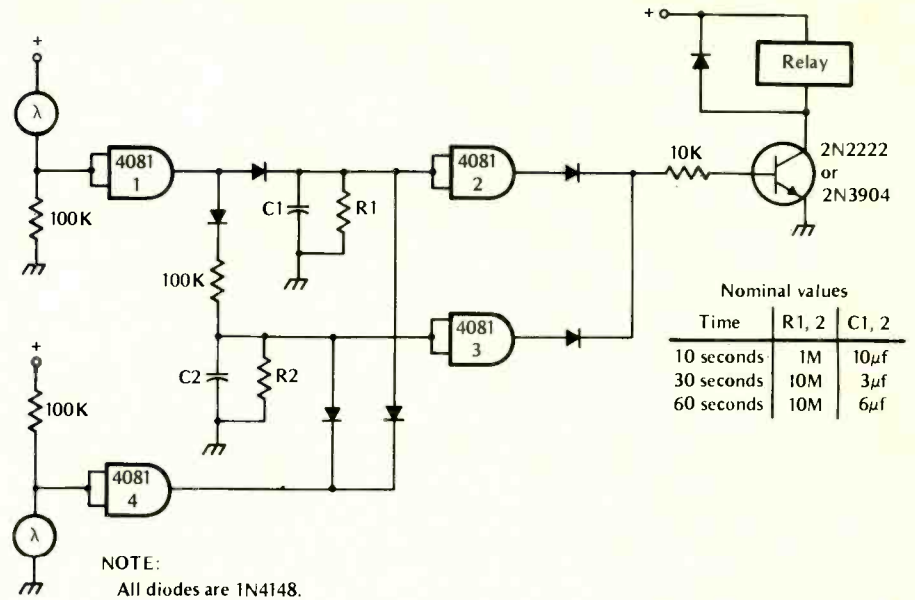

respond to room light, but does actuate when struck with your flashlight beam. Power for the unit can be supplied by a standard 9-volt battery.

The circuit functions by opening a relay contact in the speaker line. To connect the circuit, you'll have to open your

tv set and connect one of the speaker leads through the relay. Remember there are lethal voltages inside your set. Be careful. A safer way would be to use an external speaker plugged into the earphone jack, with one lead connected through the relay contacts.

reaction timer

Think you're pretty fast, eh? Well here's a reaction timer that lets you prove the point—if you can.

When a friend touches a remote "set" touch plate, a tone is sounded and the meter needle starts a rapid increase in reading. As soon as you touch your touchplate, the tone and needle travel stop.

If you're competing with friends, the fastest contestant is the one with the lowest meter reading.

You can use your VOM or a spare panel meter for the indicator. If you use an ammeter, you'll need a series resistor to convert it to read voltage. If you use a voltmeter, omit the resistor. You can change the tone by changing R_1 and C_1 . The touchplates can be any metallic object connected to the battery supply line as shown.

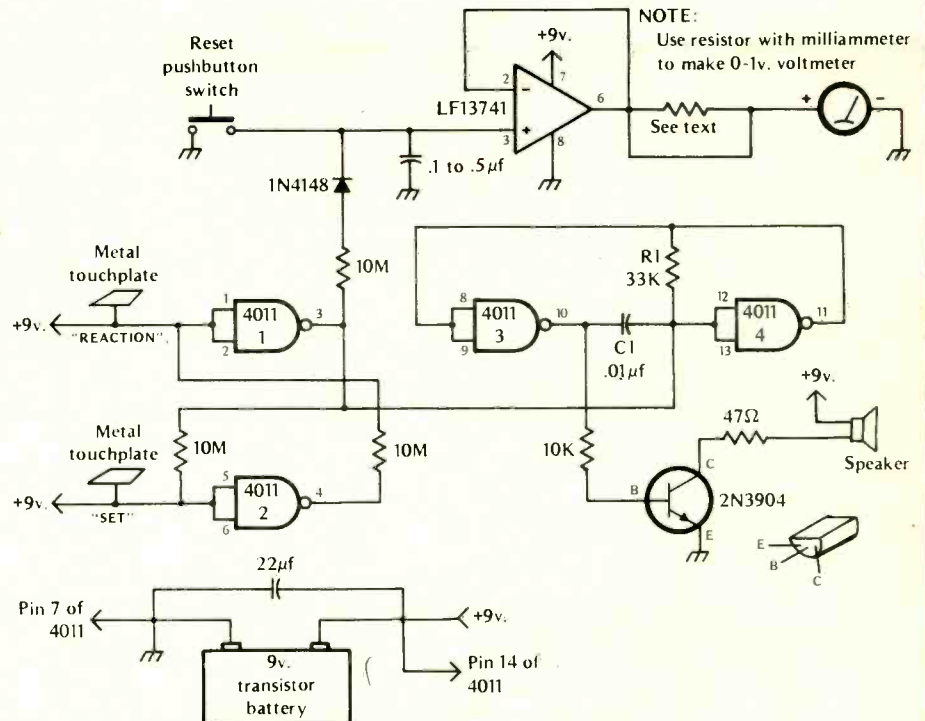

Videodisc: a colorful alternative

Whether laser beams or tiny capacitors, the pits and slots in videodiscs may bring low-cost color movies, sports, entertainment specials for your home library.

by Bob Margolin

If you're not ready to spend \$1000 or so for a VTR, a \$400 video player may be more appealing. With a player and rented or borrowed recordings, you can use your tv to view a wide variety of programs, even though you won't be able to record your own.

Two giants in the home entertainment industry — RCA and North American Philips Corporation — are just about ready to introduce another kind of video player. It's the videodisc, and it's very much like the phonograph you already have in your den. All you do is hook it to your tv set, put a disc on the turntable, move the pickup into position, and presto, you're watching your favorite feature.

Both RCA and Philips are heavily involved in the VTR market. But both believe that there is a viable disc market as well. The major advantage of the disc is price. RCA, for example, expects to provide a two-hour program for between \$10 and \$15.

At the moment, both RCA and Philips are moving ahead with different disc systems. While the VTR market is vital enough to support four different formats, the videodisc market is not. Eventually, one of the two systems will prevail, the other being relegated to the status of fond memory. Which system wins out depends on which reaches the market first, which is more reliable, and which can provide the best selection of pre-recorded discs.

Different discs

The RCA system is closest to the phonograph record you're used to handling. About the same size, its surface

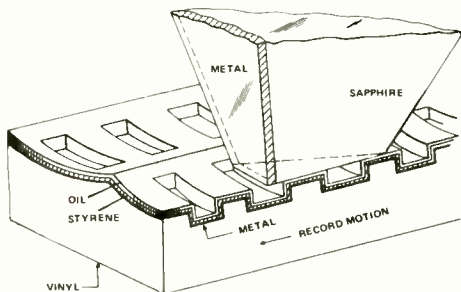

contains the same kind of groove. The pickup uses a stylus very similar to that used in your stereo pickup.

One significant difference is the way in which the signal is impressed on the disc. In a stereo phonograph record, the walls of the groove undulate in step with the program material. In RCA's video-disc, the groove walls are smooth-sided with transverse slots etched into the surface. A thin layer of metal is deposited on the disc surface after slotting, which is in turn covered by an insulating material.

The stylus consists of polished sapphire to which a strip of metal is attached. As the stylus rides in the groove, a capacitor is formed with the metal in the disc and on the stylus acting as the plates.

The actual capacitance is unimportant. What matters is the change in capacitance as the stylus travels over the slotted surface. It is this change that is processed to produce the picture you see on your tv set.

Play it again, Sam

Although there is wear to both the disc and the stylus, RCA claims each videodisc should be able to provide over 200 plays, with the stylus good for over 200 hours of use. Present plans call for the player to cost about \$400.

The Philips system uses radically different technology. Instead of grooves, tiny "pits" are etched into the surface of

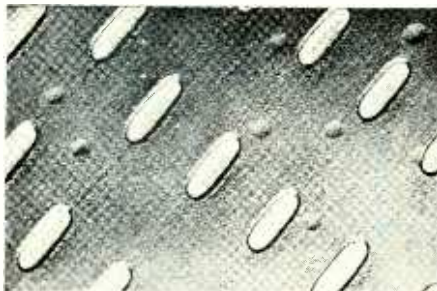

the disc. Instead of a stylus, the pickup uses a laser beam to scan the disc.

The laser beam is reflected off the disc surface and onto a photosensitive pickup. As the videodisc rotates, the laser beam alternately reflects off the smooth surface and the pits. As a pit passes through the laser beam, the angle at which it is reflected changes, which causes the reflected light beam to alternately fall on and off the photosensitive pickup. It is this change of light

intensity at the pickup that is processed to produce the tv picture you see.

Although the Philips/MCA discs only provide about half as much playing



The Philips videodisc player, to be sold under the Magnavox label, is similar in operation to a child's record player. Just open the lid, drop the disc on the turntable, and close the lid. The player does the rest automatically.

time, the "optical" system employed is said to offer other advantages over the RCA system. For one thing, the pickup is not locked into a spiraling groove. You can stop its across-the-surface travel and re-scan the same picture over again to "freeze" the action. By slowing the turntable speed, you can create "slow motion" effects. You can even reverse the action by reversing the direction the turntable rotates.

Two very large questions that have yet to be answered are how easy will it be for you to get the videodiscs themselves, and how large a selection of material will be available? Both RCA and MCA have excellent distribution networks for their phonograph records. MCA does seem to have a slight advantage in the programming department because it owns Universal, which distributes such movie smash hits as *Jaws*, *American Graffiti*, and *Airport*. 

Please turn to pages 64-67 for a complete report on videotape recorders and an explanation of how they work, by Bob Margolin, Modern Electronics' assistant editor.

Mobile antennas: fact and fiction

Your CB radio isn't worth a plugged nickel without a good antenna to squirt the signal into the air. It can be a real head scratcher, sorting through confusing claims for antenna performance. Here's a complete easy-to-understand explanation of CB antennas for cars, trucks and RVs.

by Bill Orr, W6SAI

OK SPORT FANS, let's talk about mobile antennas for two-wheelers, RVs and eighteen-wheelers. (For the uninitiated, that means automobiles, campers/trailers and tractor-trailer rigs.)

Radio transmission and reception from moving vehicles is nothing new, radio hams were doing it in the early "twenties" and Detroit, Michigan had radio equipped Bears (patrol cars) in the early "thirties". But it is only in the past few years that mobile CB radio has really caught the attention of the American

public. Some observers of society say that the big growth and interest in CB radio came about as a result of the trucker's strike in the fall of 1975. Who knows?

But the end result is that today there is more interest than ever in CB radio and a big proportion of the interest is in mobile operation.

In magazines and on TV "commercials" you'll see the advantages of mobile CB radio extolled—just the thing for highway emergencies, or to inform the little woman that you'll be late for dinner, or for the better half to tell you to stop and pick up some extra canned beans for dinner! This is great stuff, and very thrilling, if it works.

However, many CB service centers report that a vast number of CBers experience trouble with their mobile rig, and that the trouble usually centers around the antenna installation! It would seem, then, that the mobile antenna is the weak link in the communication chain which can drastically impair your enjoyment of CB two-way communication. God knows there are enough mobile antennas on the market! A quick glance through S-9 will convince you that whatever type of mobile antenna you desire, it is available, and in quantity. What, then, is the big hang-up? Why do so many CBers experience difficulties getting the CB rig from the shipping carton, and into action in their vehicle?

Well, before we examine the action, a word of advice from this Old Timer—advice that applies to CB equipment of all types, antennas included: too many CBers think the instruction manual, or sheet, is something to be thrown away with the shipping carton. As a last resort, before you panic, *read the instructions!* The manual, or instruction sheet, is included with the equipment for a very good reason. *Read it and save it!* Now, having gotten that bit of folk wisdom off my chest, let's get the show on the road.

What is the mobile antenna—and why?

The usual CB mobile antenna is a vertical metal whip of some sort mounted on the body of the vehicle. The whip is made stainless steel, or other conducting material, and is insulated from the body of the vehicle by a support structure made of nonconducting mate-

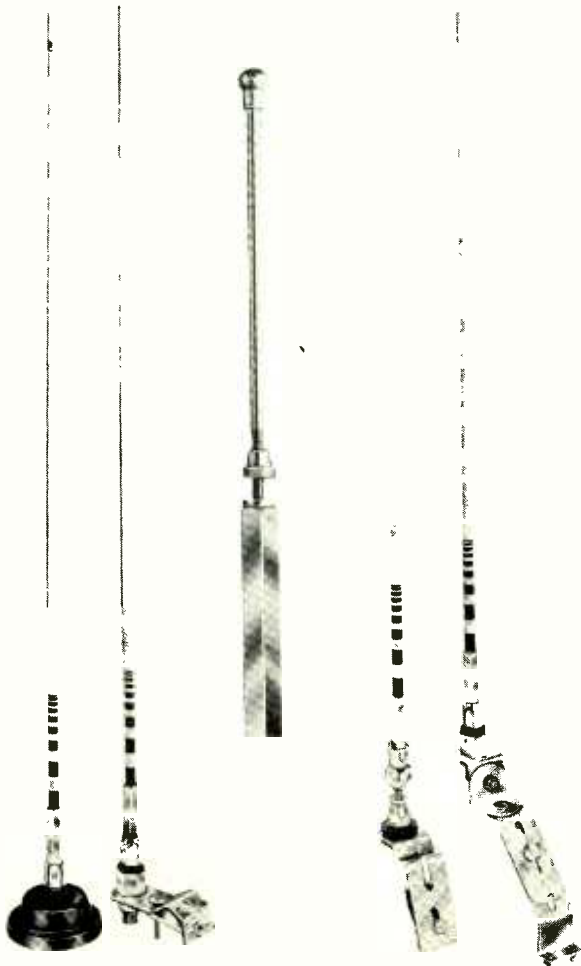

Fig. 1—Whips, whips, whips! They come in a variety of sizes with a variety of mounts. Which is best for you depends on what you want your antenna to do.

rial. Thus, there's no electrical connection between the antenna, as such, and the body of the vehicle.

By tradition, and because of ease of mounting, the mobile antenna is placed in a vertical position and for best results the antenna length bears a definite relationship to the length of the CB radio wave. The "work horse" antenna for CB mobile service is the *vertical whip*, shown in various versions by figure 1. The most popular whip is flexible, quarter-wavelength long tapered stainless steel rod having a threaded base fitting. (Better antennas use stainless steel for the whip assembly to reduce corrosion and rust). The top end of the whip should have a steel or plastic ball on it to prevent you from putting your eye out when installing it on your car. In addition, the ball insulates the tip and prevents the build-up of static electricity on the antenna, as often happens in a fast-moving vehicle in dry weather. Static electricity can cause a crackling, frying noise in the receiver that makes reception extremely difficult and has even been known to burn out the sensitive transistors in the input circuits of a receiver!

Whip antennas come in all sizes, price ranges and performance values, so let's discuss some of the more popular models.

The 102 whip

The so-called "102 whip" is 102 to 106 inches long, or nearly one-quarter electrical wavelength (Figure 2). Actually, a quarter-wavelength is closer to 106 inches, but part of the antenna length may be included in the mounting fixture and, as a result, manufactured whips take this into account and usually run only about 102 inches from top to bottom. Many 102 whips have a base section having a special $\frac{3}{8}$ " x 24 threaded post to fit most mounting devices.

Some whips are demountable, that is, the whip is held in position in the threaded post by a threaded coupling or by an *allen* set-screw (Figure 3). The user can quickly loosen the whip with an *allen* wrench and remove it for storage in the car, so that it won't be ripped off!

Generally speaking, whip length is not critical within two or three inches, and most whips are "fine tuned" by cutting one end, a half-inch at a time, until the antenna is tuned to the channel desired.

Fig. 2—The quarter-wavelength whip antenna. This so-called "102 whip" is made by a variety of manufacturers. The whip may be stainless steel, or steel coated with fiberglass. A small ball is placed at the tip of the whip to prevent you from putting your eye out when installing it on your car. The tip ball also helps to reduce build-up of static electricity on the whip. The base of the whip is threaded to fit into a spring mount and swivel ball. The split ball permits mounting the whip on a surface which is at an odd-angle to the ground.

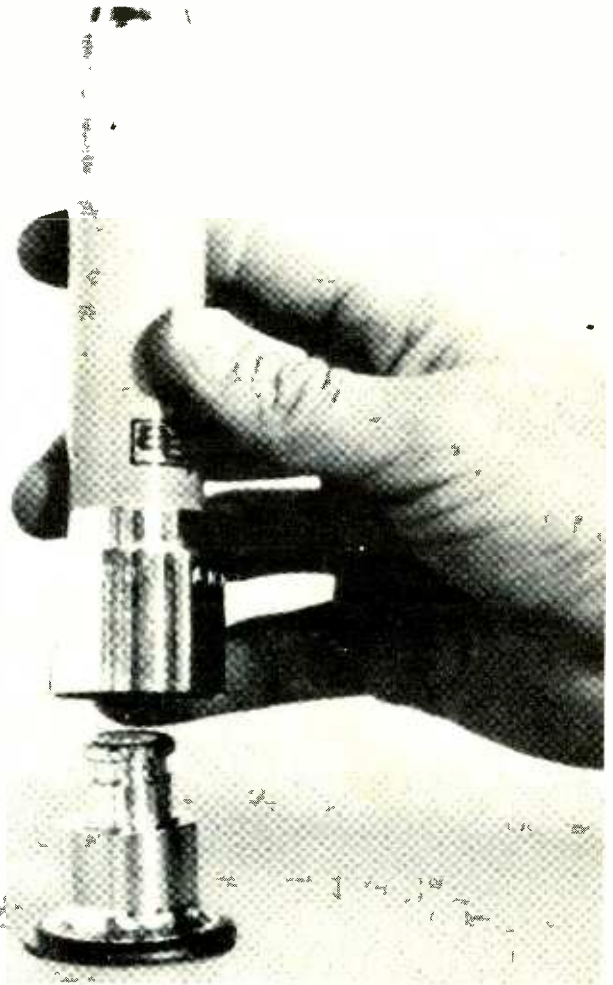

Fig. 3—This base loaded whip is quickly removable from the mount. A threaded fitting permits the whip to be taken off with a few turns. Some whips can be locked into position with an *allen* set screw to prevent them from being stolen. It is a good idea to remove the whip when the vehicle is parked in a public place so that it won't attract attention to the radio equipment in the car!

Everything else being equal, the 102 whip is just about the best mobile antenna from the point of view of overall efficiency. All of the antenna is radiating as part of it is not wound up into a coil which does no radiating. However, the 102 whip is not without its problems. First of all, it is an unwieldy device, capable of striking your garage entrance, and long enough to bang into overhead tree limbs when you drive down the street. In addition, under high speeds the 102 whip tends to bend backwards in the wind, and flop about, which often adds a very objectionable "flutter" to the signal.

Some CBers try to remedy these faults. The whip is mounted very low on the vehicle (usually on the rear bumper) so that it will not strike overhead objects, and the whip is braced to the car body with nylon cord to keep it from moving about when the vehicle is in motion.

These are not bad ideas, but when the whip is mounted low on the vehicle, the body of the vehicle tends to "shield" the antenna in certain directions and

please turn to page 82

Get a piece of the

For a new hobby or a better job, it's easier than ever to study electronics at home.

by Gerald R. Patton
Contributing Editor

You're interested in electronics and want to learn more about this fascinating realm. The electronic equipment market is expected to total \$48 billion this year and you feel this just may be the industry for your future. Or, you want to enjoy electronics as a thrilling hobby, such as amateur radio or experimenting with your very own microcomputer.

Whatever your goal, if you are out of school with job and family responsibilities, you probably find it impossible to fit your lifestyle into a classroom, even if a continuing education or vocational training course is available in your area. You also may find it difficult to just select a book or two on a subject as technical as electronics and get a really good



ME art: Chuck McVicker

Learn to repair radios, TV sets or stereos. Improve your communications skills. Gear yourself up for an exciting new hobby or train for a better job. Home study provides learning at your own pace in familiar surroundings.

\$48-billion action

grasp on it without expert guidance on materials to choose. It can be an extremely frustrating experience, to say the least.

Fortunately, another option is available in home study, popularly known as *correspondence courses*. There are several types of courses from which to choose.

Hobby courses

A new and exciting entry into the short course arena is Heath Co., the electronics kit manufacturer at Benton Harbor, Michigan. Heath is offering several "kit courses" for under \$100, including training hardware, on such subjects as DC and AC electronics, semiconductors, circuits, and digital techniques. A ham novice license course is available for \$25, and new courses will deal with microcomputers.

If you're interested in more serious career training, including preparation for passing the all-important FCC commercial license examinations, then more formal, in-depth programs offered by companies such as the National Radio Institute (NRI) of Washington, D.C., and Cleveland Institute of Electronics (CIE) in Ohio probably are for you. These courses consist of forty or more lessons, usually in small individual

manuals plus reference manuals. Kit hardware, such as test equipment or a color television to provide "hands-on" training, is provided with many such programs.

A series of open-book exams are self-administered throughout the course. These tests are then mailed in to the school, where they are reviewed and graded for you. The instructor at the school will comment on your answers and provide additional explanations and assistance either upon request or as he feels necessary. Depending upon the course, a final exam, either self-administered or proctored, signals your understanding of the lessons and qualifies you for a diploma from the school.

Did you study today?

One disadvantage of home study over a structured classroom environment is the amount of drive and self-discipline necessary to complete the program. There is no steely-eyed instructor to require excuses if you get too tired or for some other reason fail to complete a lesson the night before. There's no doubt about it: if you need outside force to get the job done, you should think twice before starting home-study training. The flip side of this drawback is the tremendous advantage of being able to set your own study schedule, limited only by the generous completion time allowed with most courses.

One very strong point of all the courses given by reputable home study

schools is the overall quality of the text material they provide. This is the heart of a correspondence course. Their texts have to be easy to read and understand in order for you to be successful with their courses. Without this, they have nothing to attract you as a student, and the big schools in the industry have been around for many, many years.

College, too

One step beyond even these complete technical programs is a series of four "semesters" of courses offered by the Center for Degree Studies of International Correspondence Schools in Scranton, Pennsylvania, which can lead to an Associate in Specialized Technology (AST) degree in electrical engineering technology or electronics technology.

This institution has accreditation by the Commission on Higher Education of the Middle States Association of Colleges and Schools, making it the first

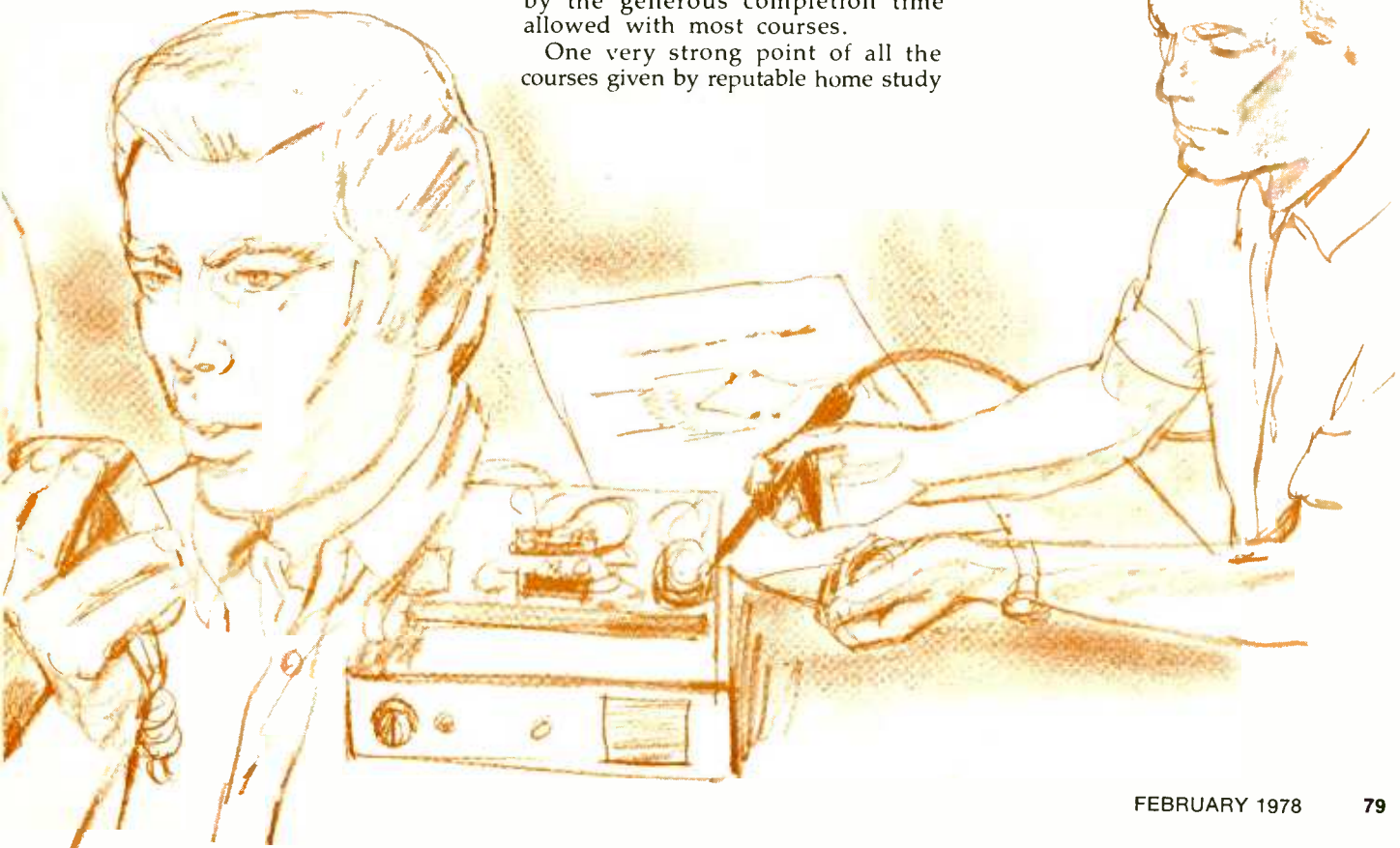

\$48-billion action

proprietary, non-traditional postsecondary institution to achieve this status.

A two-week residence requirement at Lafayette College in Easton, Pennsylvania, is an integral part of this program. ICS also offers the traditional type of correspondence course leading to a diploma.

License guarantees

If one of your primary reasons for enrolling in a correspondence school is to obtain an FCC commercial license, which is a government requirement for engineers and technicians who service and maintain all broadcast transmitters

and, indeed, nearly *all* transmitters except those licensed in the amateur radio service, then be sure to find out whether the school in which you're interested offers an "FCC license or money-back" guarantee.

Many established institutions have this provision, which means that, within a certain period of time following your successful completion of their course, if you are unable to pass the FCC exam of the appropriate class, all or a large part of your tuition will be refunded to you. The period of time covered by this type of warranty usually varies from three to six months.



Course sources

Here's a list of major schools and other sources of home study materials in electronics:

CLEVELAND INSTITUTE OF ELECTRONICS, INC. (CIE)
1776 East 17th Street
Cleveland, OH 44114

CAPITOL RADIO ENGINEERING INSTITUTE (CREI)
3939 Wisconsin Avenue
Washington, DC 20016

GRANTHAM COLLEGE OF ENGINEERING
2000 Stoner Avenue
Los Angeles, CA 90025

HEATH COMPANY
Benton Harbor
Michigan 49022

NATIONAL RADIO INSTITUTE (NRI)
3939 Wisconsin Avenue
Washington, DC 20016

NATIONAL TECHNICAL SCHOOLS
4000 South Figueroa Street
Los Angeles, CA 90037

INTERNATIONAL CORRESPONDENCE SCHOOLS (ICS)
Scranton
Pennsylvania 18515

What's it cost?

Here's a rundown on prices of 15 courses offered by National Radio Institute, Washington, D.C.:

CB radio specialist	\$595
TV/Audio servicing I	\$475
TV/Audio servicing II	\$585
Color TV servicing	\$880
Master color TV service	\$1195
Advance color TV service	\$665
Digital computer electronics	\$980
Electronics technology master	\$660
Communications electronics	\$875
FCC license	\$320
Marine electronics with FCC	\$335
Aircraft electronics with FCC	\$335
Mobile communications with FCC	\$335
Applied math in electronics	\$90
Basic Electronics	\$195

Tips and extras

Here are a few things to check out:

■ Schools offering formal correspondence courses should be approved by the Accrediting Commission of the National Home Study Council in Washington, D.C. This assures you, for example, of fair cancellation and refund policies if you are unable to complete your course.

Typically, a registration fee of \$50 or 10 percent of the tuition, whichever is less, is charged in addition to an amount corresponding to the percentage of completion of the program. For example, if you have completed less than 25 percent of the lessons, you would owe the registration fee plus 25 percent of the tuition. If you terminate your enrollment after having completed 25 percent of the lessons, but less than 50 percent, the charge would be the registration fee plus half the tuition. After 50 percent of the lessons have been completed, full tuition is required.

■ If you're a member of the armed forces or are a veteran, you'll want to be sure that the school is a participant under the G.I. bill for educational benefits. In this way, provided you're eligible, you can receive up to 90 percent of your tuition back from the Veterans Administration as you complete the course.

■ Some institutions offer optional lessons in some courses to meet specific interests.

■ Another feature sometimes available is a toll-free telephone number which you can call with specific questions and problems.

■ Many schools will prepare professional style resumes for you and will also write letters of recommendation to help you find employment in the industry. However, no reputable school can or will promise you employment following your graduation from their program.



Play chess against the computer

Playing the chess computer is easy. Beating it is not.

A computer able to play chess used to fill an entire laboratory. Not any more! Now the computer is built into the very board itself, making it only imperceptibly thicker than a non-electronic game.

Chess Challenger is an ordinary-board-sized \$199 game with a real computer inside. It's programmed at a level to teach beginners but challenge experts. It's said that average players beat the board 25-70 percent of the time.

Input to this computer is through a keyboard. Output is in red light-emitting diodes (LEDs) above the keys. The

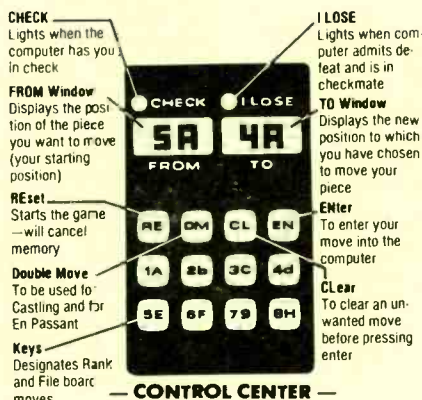

board is marked with special lettering for your use in keying in your moves. And those moves can include castling and en passant!

Chess Challenger is not a kit. It is ready to go, powered from 110-volt ac house power. Pieces are wooden.

The computer is available from Heath Co., Benton Harbor, MI 49022; Chafitz, 1055 First St., Rockville, MD 20850; and other stores.

Great for learning and practicing, Chess Challenger can tune and sharpen the game of an expert. And a backgammon version is on the way!

Your own chess partner is Chess Challenger, a computerized playing board by Fidelity Electronics.



GILFER



"NORTH AMERICA'S SHORTWAVE MAIL ORDER PLACE"

One-Stop Armchair Shopping For All SWL Needs

* Receivers — Drake, Yaesu — special mods for better performance * Frequency Readouts * Receiving Antennas * Antenna Tuners * Frequency Calibrators * Log Books * FM or TV Guides * QSL Albums * AM Pattern Maps * ITU Publications * QSL Address Books * Confidential Frequency List * Clocks * All SWL Books

The New 1978 32nd Edition WORLD RADIO TV HANDBOOK Is Ready!

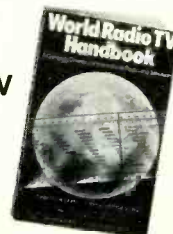

Listen to the world with this comprehensive directory of stations at your side. Best there is! Only \$11.95 ppd.

FREE SWL MINI-CATALOG GILFER SHORTWAVE

Dept. ME 2, Box 239, Park Ridge NJ 07656
CIRCLE 81 ON READER SERVICE CARD

ALDELCO ELECTRONICS COMPANY

NEW IMPROVED DIGITAL ALARM CLOCK KIT
0.5 LED Display 12 hour format
Snooze Feature
Elapsed Time
Simulated Wood Grain or Black Leather Cabinet \$24.95
12 or 24 Hour Clock Kit. Similar to above but without Alarm or Timer features Only \$23.95
Crystal Time Base Kit for 12 Volt DC use 4.95



COMBINATION FREQUENCY COUNTER & CLOCK 0.4" LED Display. .0001% accuracy. 12 or 24 hour Clock uses BAA NiCad batteries (not supplied) \$99.95
Assembled Unit 110 Volt AC Power Supply & Battery Charger 5.95

VOLTAGE REGULATORS		CLOCK CHIPS	
TO220 Package		5313	\$3.49
Positive	Negative	5314	3.95
\$1.00	\$1.25	5316	3.95
7805	7905	5375	3.95
7806	7906	CT7001	6.95
7808	7912	LOGIC PROBE KIT DIGIPEAKE-A \$11.95	
7812	7915	POWER SUPPLY KITS	
7815	7918	Includes schematic	
LM309H	\$1.10	5 Volt 6 Amp	\$17.95
LM309K	1.10	+15 Volt & -15 Volt	\$16.95
LM723	.55		
FETS 40673	1.55		
MpF 102	.55		

MA 1003 National AUTO or BOAT CLOCK MODULE SPECIAL \$21.95
With Module Three Push Button Switches AND choice of Blue, Green, or Amber Filter.

WOW LOOK AT THIS JUMBO RED LEDS
11 for \$1.00
Green, Yellow or Orange LEDs 5 for \$1.00
FND 70 CC 0.3" Display LED .49
FND 500 CC 0.5" Display LED .89
CLOCK FILTERS 2 1/8 x 5 3/4" Red, Blue, Green or Amber 60 ea

AMATEUR TV CONVERTER
Covers 420 to 450 AM TV BAND. Works on unused Commercial TV Channel. KIT ONLY \$39.95
ASSEMBLED \$49.95

BLINKY-FLASHER-TIMER KIT
Includes 555, PC Board, Parts & Instruction \$2.50

WE STOCK COMPUTER, AMATEUR, AND ELECTRONIC BOOKS AND MAGAZINES. COME IN TO OUR STORE AND LOOK US OVER. YOU'LL BE PLEASANTLY SURPRISED.
Want our catalog in a hurry? Send us a first class stamp. TAKE THE MEADOWBROOK PARKWAY TO BABYLON TURNPIKE EAST. PROCEED 1/4 MILE SOUTH ON BABYLON TURNPIKE.

VARIABLE POWER SUPPLY KITS, .5 Amps 5-15 Volt DC \$6.95
add \$1.00 per kit shipping...5 Amps 12-28 Volt DC 6.95

Visit Our Store. Hours 9:00 A.M. to 6:00 P.M. Mon. to Fri. Sat 9:00 A.M. to 2:00 P.M. Phone Orders accepted. Visa & Master Charge. Add 5% FOR SHIPPING. ORDERS UNDER \$10.00, add \$1.00. Foreign Orders add 15% shipping (Except Canada & Mexico) send Certified Check or Money Order in USA funds.

ALDELCO

2281 M Babylon Turnpike, Merrick, New York 11566
516 378 4555

CIRCLE 99 ON READER SERVICE CARD

Mobile Antennas

continued from page 77

radiation from the antenna is not the same in all directions from the vehicle.

Short, loaded miniature whip antennas are becoming increasingly popular among mobile CBers. These whips are from 18 inches to 80 inches long, with the missing portion of the whip that is required for a full quarter wavelength system being wound up in a *loading coil* placed in series with the whip. The coil may be either at the base of the whip (Figure 4), or in the middle of it. Since a portion of the normal, full-size antenna is missing (wound up in the coil to conserve height), the efficiency of the whip suffers to a degree.

Fig. 4—The base loaded whip. This compact whip antenna is about 42 inches high and is designed for roof or rear deck mount. The missing portion of the whip is wound up into a loading coil, which may be seen at the base of the whip, just below the flexible spring. Whips of this general type may be obtained having an overall length of 18 to 80 inches. The longer whips have greater efficiency than the shorter ones. Some models of the mini-whip can be adjusted to frequency by trimming the whip length an inch at a time.



Fig. 5—The center loaded whip. The efficiency of a short whip can often be improved by moving the loading coil from the base to the center of the antenna. This 28 inch high mini-whip is designed to mount on the rain gutter. A special clamp permits quick and easy attachment to the rain gutter of a vehicle. Make sure that this base clamp penetrates the paint of the vehicle to make a good metal-to-metal contact for grounding purposes.



Very short mini-whips (18" to 36") that have the loading coil at the base seem to average about ten to twenty percent as efficient as a full size whip, with the greater portion of the transmitter power wasted in the form of heat in the coil. Longer mini-whips, of course, have higher efficiency.

The mini-whip antenna

Many CBers are willing to accept the trade-off of antenna efficiency for convenience, and whip lengths of 48" to 80" are becoming very popular. Because the mini-whip is shorter, it can be mounted higher on the vehicle, atop the roof and atop the rear trunk area being two convenient mounting places. Some antenna manufacturers state that the loss in efficiency brought about by the use of a mini-whip antenna is more than compensated for by the ability to mount the whip antenna at a higher point on the car—and they may very well be right. Since not everyone drives the same kind of car, RV or truck,

it is difficult to make specific comments, and observers such as myself are reduced to generalities which are based upon common sense. Here are a few such generalities:

- 1—Longer antennas are more efficient than shorter ones. Use the longest whip antenna (up to a quarter-wavelength) that you can.
- 2—Mount the whip as high on the vehicle as you can.
- 3—Don't let the body of the vehicle cast a "shadow" on the whip. (One of the worst installations is to mount a whip on the rear bumper of a station wagon, as the body of the wagon is very close to the whip and creates a radio "shadow" around the whip).

Mini-whips make use of an inductor called a *loading coil* to establish the *electrical* length near resonance, or about 102 inches. As I said before, the portion of the antenna wound up in the coil doesn't do anything as far as radiating the signal goes. Theoretically, it is possible to place the loading coil at any point in the antenna. Placing the coil at the base of the mini-whip makes a physically strong assembly that has very little wind resistance. Antenna efficiency, however, can be raised an appreciable amount by placing the loading coil near the center of the whip (Figure 5), rather than at the base. Raising the coil beyond the center of the antenna does not "buy" much, and tends to make the antenna top heavy and makes adjustment more critical.

Once again, the user is confronted with a trade-off in values. Which is more important, antenna efficiency or wind resistance? Is it more aesthetic to use an antenna with a base loading coil, or to use one with a (relatively) unattractive loading coil in the center of the antenna?

Some manufacturers place the loading coil near the mid-point of the mini-whip in order to boost antenna efficiency, and then cut down the length and diameter of the coil to decrease wind resistance. The improvement in efficiency in such circumstances is doubtful.

The problem confronting the manufacturer, seller and end user of any mobile antenna is that it is extremely difficult to determine the overall efficiency of the antenna, especially when it is to be mounted on a vehicle of the user's choice. Measurements of antenna efficiency and performance are costly and difficult to perform. Some of the larger manufacturers have an "antenna range" where measurements may be made under controlled conditions. On a typical range, the antenna under test is placed in the middle of a large sheet of metal and readings of the signal strength from the antenna are taken at various points around the compass, several hundred feet away from the antenna. In some instances, the antenna may be actually mounted on a vehicle, or truck.

Sad to say, performance of a given antenna varies greatly from vehicle to vehicle and from truck to truck.

please turn to page 86

BY THOMAS ROHR

This month's Basic program saves time and effort in transistor amplifier calculations

Here's the first in a series of computer programs which will be simple to understand, easy to run on popular home computers and, usually, in beginner's Basic language. Our *Program of the Month* will show what a program looks like, how its steps are logical and, with study, how to write other programs for your personal computer. Our first package helps you calculate voltages, current, input resistances and the gain of transistor circuits.

The transistor amplifier circuit of figure 1 is perhaps the most common circuit configuration. It is an NPN transistor used in the common-emitter circuit to provide gain in audio and other low-frequency applications. Depending on the values of the resistors and capacitors used, it can provide gain in the range of five or less up to a hundred or more. It can operate at supply voltages from a few volts up to a hundred volts (with suitable transistors), at currents ranging from a fraction of a milliampere up to several tens of ma.

Our computer program, written in the Basic programming language used in home as well as professional computers, calculates the voltages and currents in the circuit, as well as the input resistance and the gain of the circuit. The voltages and currents are useful in troubleshooting, since they are easily measured with almost any inexpensive multimeter.

If you have a circuit to check, you can use this program to calculate the voltages and currents that it should have, and then compare these with the values actually measured. The gain, which describes how much larger the ac output voltage is than the input, can also be measured with fairly inexpensive equipment. The input resistance, while not especially useful for troubleshooting, is useful in deciding what can be connected to the amplifier's input.

Even if you do not have access to a computer, the program can still be interesting. By studying it, you can see that the Basic programming language is

BASIC PROGRAM FOR TRANSISTOR AMPLIFIER CALCULATIONS

```

1 PRINT "ENTER VALUES OF VCC, R1, R2, R3, R4, R5 (IN OHMS)"
2 INPUT S, R1, R2, R3, R4, R5
3 PRINT "ENTER YOUR VALUE OF BETA"
4 INPUT B
5 V = S * R2 / (R1+R2)
6 R = (R1*R2) / (R1+R2)
7 I1 = (V-0.7) / (R + B*(R4+R5))
8 V1 = V - I1*R
9 I2 = I1*B
10 V2 = S - I2*R3
11 V3 = I2 * (R4+R5)
12 D = 0.025/I2 + 2
13 G = R3 / (R4+D)
14 T = B * (R4+D)
15 N = (R*T) / (R+T)
16 PRINT "BASE CURRENT IS "; I1*1000; " MILLIAMPERES"
17 PRINT "COLLECTOR CURRENT IS "; I2*1000; " MILLIAMPERES"
18 PRINT "EMITTER CURRENT IS "; I2*1000; " MILLIAMPERES"
19 PRINT "BASE VOLTAGE IS "; V1; " VOLTS"
20 PRINT "COLLECTOR VOLTAGE IS "; V2; " VOLTS"
21 PRINT "EMITTER VOLTAGE IS "; V3; " VOLTS"
22 PRINT "INPUT RESISTANCE IS "; N; " OHMS"
23 PRINT "THE GAIN OF THE AMPLIFIER IS "; G
24 PRINT
25 GO TO 3
26 END
    
```

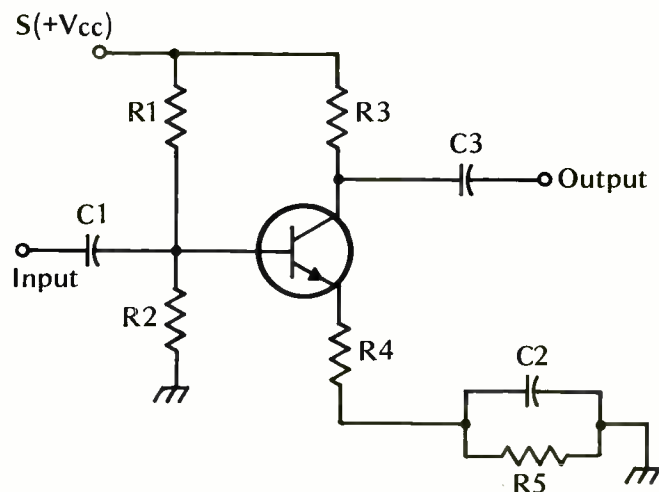

Figure 1: schematic diagram of amplifier

quite easy and straightforward to use and understand.

As most programs, this one has a short section at the beginning which asks for the user to enter the values of the supply voltage, the five resistors, and the beta of the transistor (also called h_{fe} in the transistor spec sheets.) The center section of the program calculates the results, while the last section of the program prints them out in an orderly format.

As it turns out, the circuit's operation does not depend very much on the beta of the transistor at all. This is one of the reasons why it is so popular. To illustrate this point, the program has an instruction at the end which says *GO TO 3*. This returns the computer back to line 3, and allows the same set of calculations to be repeated, but with a different value of beta. A sample set of calculations is shown beneath the program listing.

If you want to use the formulas without having a computer, the following calculations are done. Start with these given values:

- S = value of dc supply voltage (also called V_{cc})
- R_1 = top base bias resistor (see figure 1)
- R_2 = bottom base bias resistor
- R_3 = collector resistor
- R_4 = emitter resistor which is unby-passed by capacitor
- R_5 = emitter resistor which is bypassed
- B = transistor beta.

If the Beta is not known, a good trial value is 100 for small transistors. If no emitter resistor is present at all, use 0 ohms for R_4 and R_5 . If the entire emitter resistance is bypassed by a capacitor use 0 ohms for R_4 . If no emitter bypass capacitor is used, then use 0 ohms for R_5 .

Each line of the Basic program has a line number, which identifies the line to the computer. Lines 5, 6, and 7 are performed, in that order, to find I_b , the base current. Arithmetic formulas in Basic are written in the same way as they might be written in algebra, except that they must be written all on one line. Thus line 5 could also be written as

$$V = \frac{S R_2}{R_1 + R_2}$$

but the one-line form used in the program is equally easy to understand. The only strange symbol is *, which means 'times'.

To solve the problem without a computer, the equations are done in order as listed in the program. After the base current is found in line 7, base voltage V_1 is found in line 8, followed by collector current in line 9.

The collector and emitter voltages are found next in lines 10 and 11. Following this, lines 12 and 13 are done to find the gain G, followed by lines 14 and 15 to find the input resistance N.

The calculated values then are printed

by the computer using lines 16 through 23. In each case, a *PRINT* instruction tells the computer to start a new line, print the words enclosed in parentheses exactly as shown, followed by the value of the calculated result. Since the currents were found in amperes, each current value is multiplied by 1000 in the *PRINT* instruction to convert it to milliamperes.

After the last printout in line 23, line 24 says *PRINT* one more time, but without specifying anything to be printed. This is used to skip a line in the printout. Then the program says *GO TO 3*,

which instructs the computer to return to line 3 and start again from there. This allows you to keep the same resistor and voltage values specified at the beginning, but enter a different value of beta. The computer will repeat the program as long as you wish, allowing you to try different values of beta each time.

The printout of the results shows the values calculated by the program for the typical circuit of Figure 2. As you can see, doubling the value of beta, from 50 to 100, has very little effect on the results. Only the input resistance changes markedly.

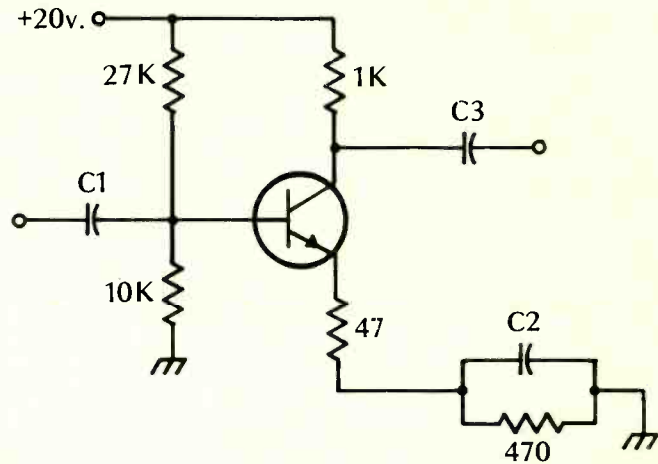

Figure 2: sample circuit

SAMPLE RESULTS FOR CIRCUIT OF FIGURE 2

```

ENTER VALUES OF VCC, R1, R2, R3, R4, R5 (IN OHMS)
?20, 27000, 10000, 1000, 47, 470
ENTER YOUR VALUE OF BETA
?50
BASE CURRENT IS .141954 MILLIAMPERES
COLLECTOR CURRENT IS 7.09772 MILLIAMPERES
EMITTER CURRENT IS 7.09772 MILLIAMPERES
BASE VOLTAGE IS 4.36952 VOLTS
COLLECTOR VOLTAGE IS 12.9023 VOLTS
EMITTER VOLTAGE IS 3.66952 VOLTS
INPUT RESISTANCE IS 1931.14 OHMS
THE GAIN OF THE AMPLIFIER IS 19.0396

```

```

ENTER YOUR VALUE OF BETA
?100
BASE CURRENT IS 7.97563E-02 MILLIAMPERES
COLLECTOR CURRENT IS 7.97563 MILLIAMPERES
EMITTER CURRENT IS 7.97563 MILLIAMPERES
BASE VOLTAGE IS 4.8234 VOLTS
COLLECTOR VOLTAGE IS 12.0244 VOLTS
EMITTER VOLTAGE IS 4.1234 VOLTS
INPUT RESISTANCE IS 3040.91 OHMS
THE GAIN OF THE AMPLIFIER IS 19.1811

```

Repeaters

continued from page 53

microprocessor control circuitry for their repeater. It almost thinks for itself.

Amateurs in Vermont use a Burlington machine with so many bells and whistles hooked up that it even tells when the tones you send to it are wrong.

In Southern California, Nevada and Arizona, hams can instantly link up several local repeaters to cover thousands of square miles of countryside when needed.

These examples are reproduced

everyday across America. There's hardly a square mile of turf where you are out of reach of one repeater or another. And there are a great many more repeaters in Canada, Europe and other parts of the world.

In the air everywhere

You don't have to be a licensed amateur to listen to the fun if you have a receiver to tune in. Chances are you do have one: a public-service-band police scanner.

The two-meter ham band, with the largest number of repeaters of the six

bands where they are legal, is adjacent to the VHF-High Police band in the spectrum. High-band scanners often cover 144-174 MHz. Hams are at 144-148 MHz. Thousands of two-meter repeaters are on the air.

The second most popular band is 442-450 MHz, adjacent to the 450-512 MHz UHF public service band.

Other ham repeater bands are 10 meters (29.5-29.7 MHz); 6 meters (52-54 MHz); 1 $\frac{1}{4}$ meters (222-225 MHz); and 1215 MHz. Hams operate tv repeaters, capable of retransmitting video as well as audio, in the 442-450 MHz UHF band. 

800 channels in one radio

Small ham radios, like small CB sets, make the hobby fun. As transceiver technology advances, radios get more features and better specs while growing smaller.

Yaesu, Kenwood, Wilson, ICOM, Midland and other manufacturers have been able to cram 800 channels into under-dash mobile transceivers about the same size as modern 40-channel CB radios.

Most of the current crop of amateur radio fun gear operates in the two-meter 144-148 MHz ham band. Some radios, which look and feel the same, operate in the 220-225 and 420-450 MHz bands. The radios are used for friendly chatting and public-service work through some 3000 repeaters on the air in North America (see: *Repeaters are the best thing that's happened in ham radio since sideband*, page 52).



Wilson Electronics' 1405 handheld has a five-watt transmitter and a receiver as sensitive as many larger mobile radios. Such a low-powered handheld can be used for contacts from 20-100 miles through repeaters.

With so many repeaters on the air, an individual amateur can have a seemingly-endless string of friends for rag-chewing on the way to work or on a transcontinental journey. There are dozens of different repeater frequencies, called *channels*, in use. At \$10 a pair,



A powerful 800-channel radio is the Midland 13-510 with 25 watts.

amateurs tire of buying crystals for new channels. So, the advent of *synthesized* radios was inevitable.

Repeaters listen on one frequency and retransmit what they hear onto another frequency. For example, a popular



Heath HW-2036, under-\$300 radio with 400 channels, is a popular kit used by amateur radio operators for conversations through repeaters. The telephone-style dialing pad in the microphone permits "autopatch" telephone calls through repeaters.

repeater pair is 146.34 MHz and 146.94 MHz. The individual amateur transmits his signal to the repeater on 146.34 The repeater retransmits that out on 146.94 MHz for other hams to hear. There are many such repeater pairs in the 146-148

MHz portion of the two-meter band alone, with other frequencies in use too.

If a radio is capable of transmitting and receiving on frequencies every 10 kilohertz (kHz) from 144-148 MHz between 144-148 MHz, it has 800 channels capacity. If it can do the same steps up from 146-148 MHz, it is a 400-channel radio.

Heathkit and others manufacture 400-channel radios. Most 400 and 800-channel transceivers run either 10 or 25 watts

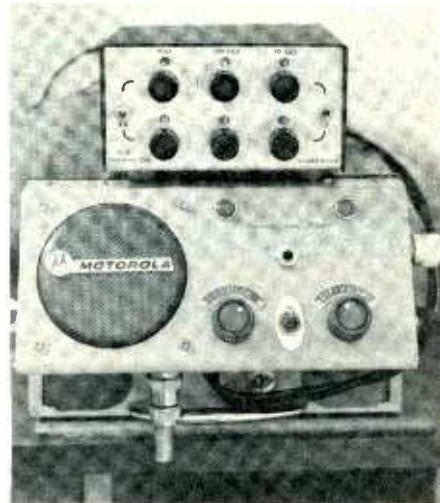

Many amateurs use older, surplus police and fire department radios. A GLB synthesizer converts a one-channel Motorola to 400 channels.

transmitter power. Range through repeaters is 20-100 miles.

Synthesized two-meter radios are \$250-\$500.

Smallest two-meter radios today are battery-portable handhelds. These crystal-controlled transceivers are used by amateurs for a wide variety of fun, games and public-service work. Wilson, Standard, Regency, Genave, Motorola, Hy-Gain and others have sets in use by amateurs.

Mobile Antennas

continued from page 82

The irregular body of the vehicle distorts the antenna pattern so that reception and transmission varies greatly, depending upon the direction from the vehicle the measurement is being taken.

This is little comfort for the CB buyer. He would have to have a whole room full of expensive instru-

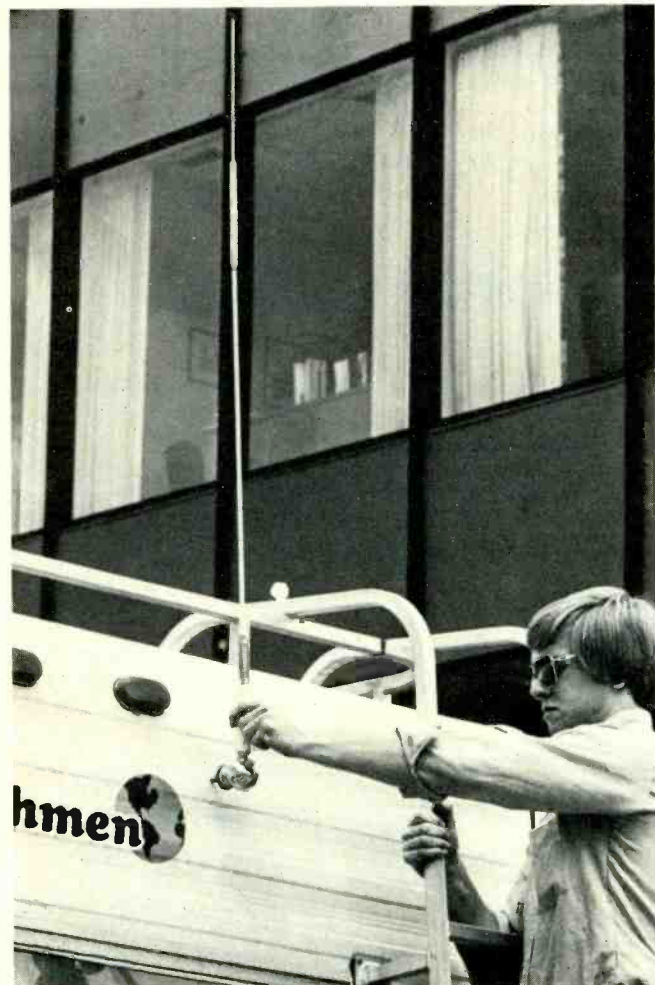

Fig. 6—A few mobile antennas such as this Breaker Corp. Model 10-500 are specially designed for use on fiberglass-bodied RV's, campers and sports cars.

ments, and a large "antenna range" in order to make comparisons between mobile antennas, and the results he would get from these measurements would vary from vehicle to vehicle. And it is asking too much for Yours Truly to state that one antenna, or type of antenna, is better for your vehicle than another. In the last analysis, the one that works *best for you* is the best one for you!

When all the smoke dies away, is there a real difference between an unloaded, full-length whip, a bottom-loaded mini-whip and a center loaded mini-whip? I asked a friend of mine that question. He's an antenna engineer for a very large antenna company that makes mobile antennas for CBers, radio hams and the military. Here's his reply:

"Well, the full length, 102 inch whip is a great antenna. If you use a super-stiff spring in the mount you

can keep it upright at normal highway speeds. But it tends to bend over at high speeds. And if you hit a tree with it—that's all, brother!

"Center-loaded mini-whips tend to be a bit better as far as efficiency goes than base-loaded whips, but they sway about in the wind and the motion detunes the whip, imparting a flutter to the signal unless the whip is very rigidly made. The bottom loaded mini-whip is very stable under all road speeds and has very little bending action at high speeds. It's more durable because it is quite short and can't be battered about by trees. But the base-loaded whip has less overall efficiency than the other two types. Also, it can be detuned easily by nearby objects. Even walking close to the body of a vehicle with a base-loaded mini-whip can detune the whip.

"My advice to the CBER is to keep his eyes and ears open. See what the other CBERs are using in the way of antennas. See who has the best and most consistent inobile signal. Examine the whip antennas at your local CB outlet. Look at the antenna of your choice. Is it well made? Corrosion resistant? You can tell a lot by merely eyeballing the antenna.

"Don't forget that the automobile forms the ground system for the whip antenna. Some vehicles with a fiberglass body—such as the Corvette—don't provide a very good ground system. In this case, the best thing to do is to cover the inside of the rear of the vehicle with self-adhesive, aluminized tape. The tape is put everywhere you can reach on the inside and then connected to the ground connection at the base of the antenna by a very short piece of wire. Some antenna manufacturers sell a ground kit for this problem (*the Antenna Specialists Co.*, 12435 Euclid Ave., Cleveland, Ohio 44106. Ask for Ground Kit M-262)."

The final wrap-up

Look through the pages of S-9 and read all the advertisements for CB antennas. You can get catalogs of many of these outfits at your local CB store, or you can write directly to the manufacturer for his catalog. I'll bet you would make him happy if you enclosed 50¢ postage, too, as a lot of the catalogs are quite weighty and costly to produce and mail. Spend an evening reading the literature, and when you finish, you'll have a good working knowledge of mobile antennas. Don't let the exotic antenna names "snow" you; antenna manufacturers have the same weakness prevalent in the automotive field—that of giving exotic names to rather mundane products!

Next, examine your vehicle, catalogs in hand. Where can you mount the antenna? How much overhead can you afford? Once you answer these two questions, you'll have come a long way in deciding what type of mobile antenna is best suited for your particular installation.

Next month's column will discuss antenna mounts and how to mount the mobile antenna on a number of vehicles. Until then, may all your signals be wall-to-wall and tree-top-tall!



how it works

ONE PIECE OF GEAR EXPLAINED

BY ANTHONY R. CURTIS

Now there's even a computer buried inside a stereo cassette deck with a command post fit for a king.

Want to play the fifth cut on your favorite cassette music tape at 11:13 every morning? Skip the sixth cut, which sounds like last year's hog-calling contest? And save the seventh for wake-up tomorrow morning? You can do all that, and more, by hooking a computer to your tape deck.

Sharp Electronics Corp., 10 Keystone Place, Paramus, NJ 07652, is first in the audio industry to do just that.

Officially called, "Computer Controlled Stereo Cassette Deck RT-3388," it has five forms of memory. It can be directed to find the start and automatically play any song on a cassette by going either forward or in reverse. It can be programmed to turn itself on and off, and has both rewind and tape counter memory. It can even be programmed to repeatedly play a certain segment of a tape.

According to Charles Daigneault, vice president of Sharp's Consumer Electronics Division, the under-\$300 RT-3388 is a significant technological



Tweezers show size of the large-scale-integration circuit "chip" which is the computer heart of Sharp's RT-3388 stereo cassette deck.

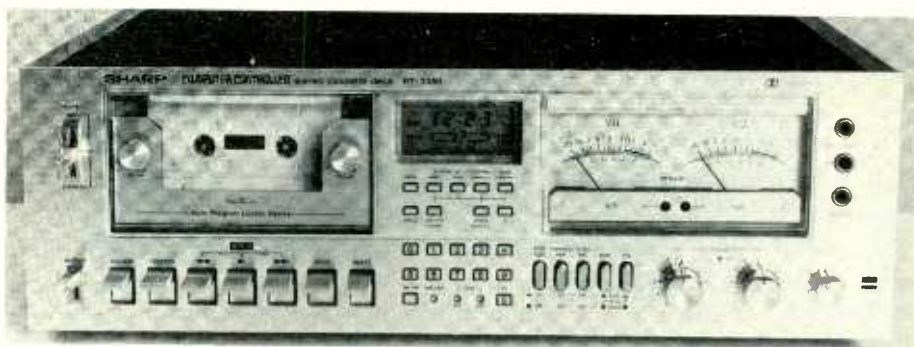

Sharp's new cassette deck is the first in the audio industry with a microcomputer built in. With five memories, it can find the start and automatically play any song on a cassette by going either forward or reverse. Programmable to turn itself on or off, it has both rewind and tape-counter memory. It even will repeat plays of one song.

breakthrough in tape equipment.

"Operation of a tape deck generally involves a lot of guesswork and annoying delays," Daigneault says.

"Incorporation of a microprocessor eliminates these problems and insures that deck operation, including finding the start of a song, replaying a specific section of tape, and setting up timed recording and playback operations, can be accomplished easily and accurately."

Sharp eye

According to Daigneault, Sharp Corporation in Japan could develop the RT-3388 because it was able to combine the technology of its exclusive "Sharp Eye" Automatic Program Search System (APSS), with its ability to design and manufacture the tiny integrated-circuit chip that is the microcomputer.

APSS, which has been on Sharp tape products for several years, enables a listener to skip ahead to the next selection on a tape, or back to the start of the selection being played.

Among the capabilities of the new computer-controlled stereo tape deck:

■ It can be directed to find the start of any song on a cassette. Through an automatic *program locate device*, it searches out the non-signal segments of

a tape and can skip—either forward or in reverse—up to 19 songs and stop, or start playback of the desired song automatically. Thus, the listener can play only the songs he wants to hear and in the order he wants to hear them. He can switch from song one to song five, then back to song four, on to song nine, and then back to song two.

■ It has *tape counter memory*, enabling a listener to locate a specific number on the tape counter. And, the counter memory button can be directed to remember that number and recall it when so directed. For example, if a listener has a favorite aria in an opera, he can automatically switch to that section without listening to earlier parts of the opera.

■ It has a *memory rewind* function which can be used to reset the tape counter to "0" at any point on the tape. When put into the rewind mode, the tape will stop at that reset "0" point, or start playback automatically depending upon which button is depressed. The same opera listener might want to hear the last three arias a second time after the opera is completed. He can go back to that point on the tape by programming this memory rewind function.

■ By using a *combination* of memory rewind and counter memory, it is possi-

ble to mark off a specific section of the tape to be replayed. Then, by entering this section into the microprocessor memory bank, and through the use of direct memory, the listener can direct the tape deck to replay this section as often as desired. The listener, for example, can have a special section of a symphony replayed by depressing the proper buttons. It will play and stop when the section ends. To replay it again, the listener just has to push the direct memory button and rewind. And, he can continue to repeat this section as long as the cassette remains in the machine.

■ It can be programmed to turn itself

on at a certain time of day, or off, or both *on and off*. Thus, a listener can arrange to record a program from any source when not at home. This programmed time on/time off can be stored in the machine and recalled each day. For example, a person can arrange, each day, to have the deck come on, record the 6-6:30 news, and shut itself off when it goes off the air. The receiver or amplifier plugs into an ac outlet in the rear of the cassette deck.

■ It has a *direct memory* function which instantly memorizes any point on the tape for a single playback. Thus, a listener can mark off any spot on the tape for replay by pushing the direct

memory button at the point of desired future replay. The listener can then recall that point later on.

■ It has an electronic *tape counter* assuring accuracy in all microprocessor-controlled functions. A seconds counter is also included. This can be set to count the number of seconds a tape has been running during recording or playback. It can also be used to determine approximately how much time is left on the tape when recording.

Heart of the microprocessor unit is an LCD (Liquid Crystal Display) digital quartz clock and *command post* that serves as the headquarters of the operation. Time is displayed in either twelve hour day, with am/pm displayed, or twenty-four hour day. And the command post also tells the listener what else is taking place.

Arrows indicate when the deck is in fast forward, reverse, or play mode. Footage can be digitally displayed. A symbol comes on when the *Dolby* noise reduction system is on. When the automatic program locate device is on, the listener can watch the countdown to the song he selected as numbers flash on the display.

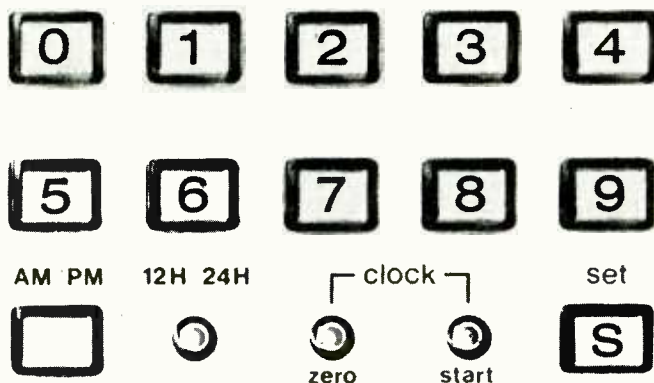
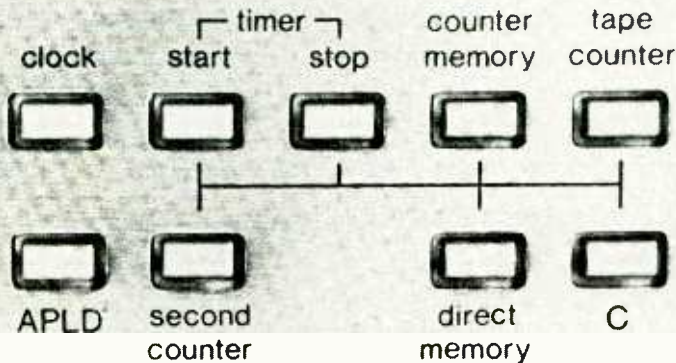
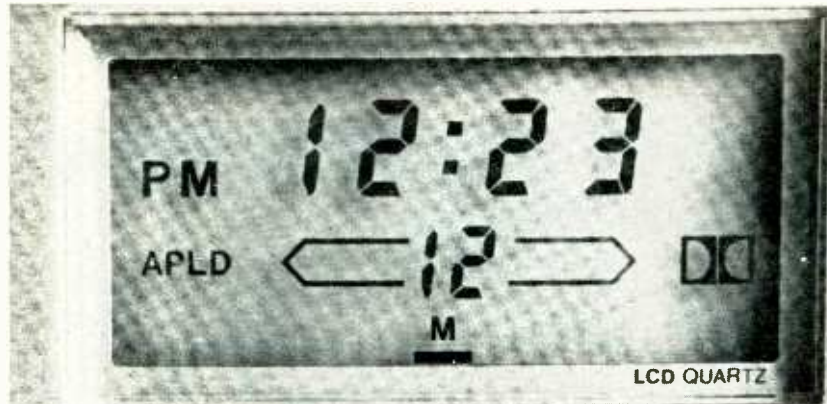

Heart of the Sharp computer-controlled stereo cassette deck is an LCD (liquid-crystal display) digital quartz clock and this "command post." Time is displayed in either 12-hour am/pm days or 24-hour days. The command post also tells what the computer is doing at any one time. Arrows point when the deck is in fast forward, reverse, play. Footage is shown. A symbol flashes when Dolby is on. You can watch the countdown to a specific song you have selected on a tape as the automatic "program locate" works; numbers flash by. Pushbuttons below the LCD control microprocessor actions in the under-\$300 deck.

Fail safe

In order to assure accuracy of the clock and to preserve its memory function, the microprocessor automatically switches the clock to built-in battery operation during a power failure.

In designing the RT-3388, Sharp did not just concentrate on the microprocessor.

"We were just as concerned with providing high performance standards," Daigneault says. "That's why we have included such features as a Dolby noise reduction system, a bias and equalizer tape selector and an ultrahard permalloy record/playback head."

Other features include:

■ An *editor button* for recording puts a non-signal segment between songs to facilitate the APLD search.

■ A full *automatic stop* mechanism with a Hall Effect IC.

■ A friction damped cassette holder for gentle cassette release and less wear and tear on the compartment door. The cassette compartment is lighted. The compartment door can be removed easily in order to facilitate cleansing of the deck heads.

■ Independent mic/line circuits make *microphone mixing* possible, permitting added versatility and allowing creative combinations during recording and playback.

■ Separate VU meters and peak level indicator.

■ LED recording indicator.

■ Output level control.

■ The pause key doubles as the standby key for timed recording and playback programs.



How to kill ignition noise

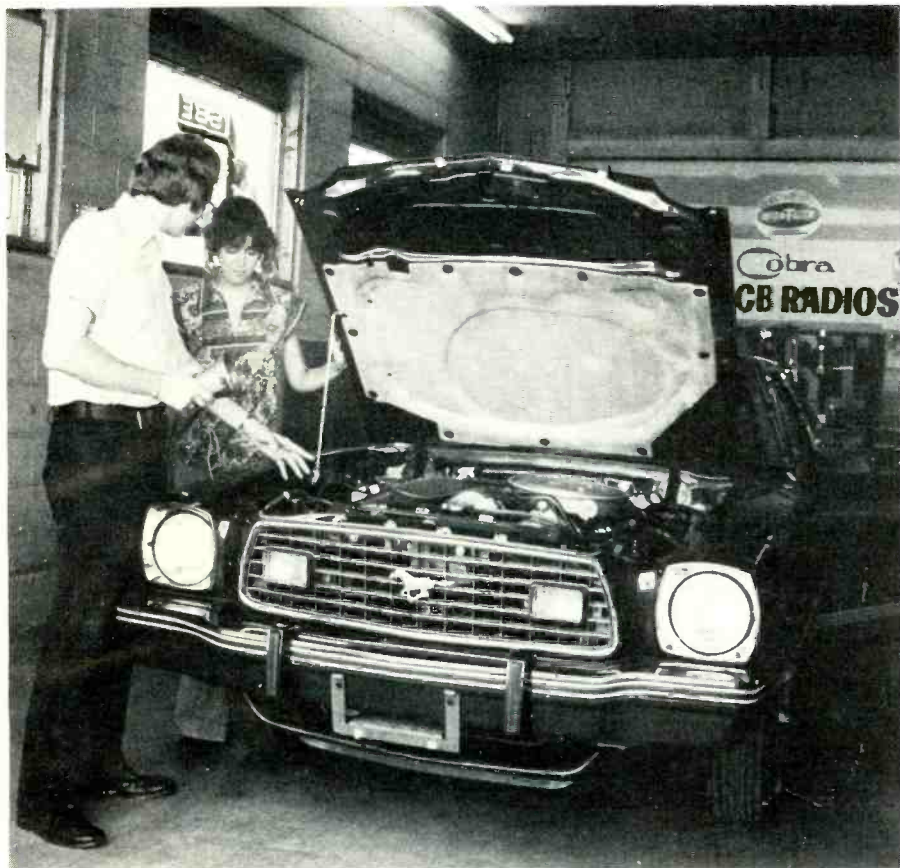

Radio hash, thrown out by your automobile engine, can wreck CB, ham and other two-way mobile reception. Now something can be done. Here's how to cut the noise and suppress interference easily and efficiently.

by R. W. Woodbury

Manufacturers of CB and other 2-way radios strive to produce communications equipment providing clear, clean reception. Most radios are designed with sophisticated circuitry incorporating safeguards against generating noise from within. But even the best of equipment cannot assure interference-free reception when the source of vehicular noise happens to be from devices such as generators, alternators, voltage regulators, ignition coils, etc. Vehicular electrical systems produce one of the worst possible environments for radio reception.

In order to reduce this type of interference, you must take up where the radio manufacturer left off . . . he did all he could to keep his equipment from emitting interference, now it's up to you to suppress vehicle originated noise at its source.

Take time to do it right

Satisfactory interference suppression can only be achieved if all components are properly connected where necessary and grounded where necessary. Be sure that paint, oil, grease, dirt, or rust is removed from those areas where good electrical contact is required. This means those areas where filter capacitors

will be mounted by their mounting straps and/or brackets. Scrape or wire-brush these areas down to bare metal. When you mount components, use clean hardware and sharp-toothed lock-washers to further ensure positive ground connections. Where wires connect to filter capacitors, be sure that connections are electrically and mechanically good. Every soldered joint must be sound. Tape all
(continued)

SAFETY PRECAUTION

Before carrying out any of the procedures outlined in this article which pertain to mobile radio interference, REMOVE BOTH RED (+) and BLACK (-) CABLES FROM BATTERY TERMINALS. *Failure to remove both cables may result in personal injury.* Follow all installation instructions completely and in the correct sequence. Automotive wiring can be hazardous since the battery can deliver hundreds of amperes instantaneously. Such high currents can heat up finger rings, pliers, and screwdrivers, with resultant burns and other possible physical injuries.

exposed connections where there is the slightest possibility of accidental contact with other wires, the grounded engine, or nearby accessories. Whenever it becomes necessary to cut the wiring leading to an alternator or generator in order to put a filter into the circuit, use cable connectors, such as Sprague QH2-5 or QH2-10, on the cut ends to ensure positive and permanent connections.

Careful attention to every aspect of installation of filter components will result in improved radio reception and tape playback.

Pre-filtering suggestions

When installing or replacing radio or audio equipment in your car, truck, boat, or tractor, these simple suggestions will minimize any additional steps for reducing interference:

1. Check all suppression components installed as original equipment by the vehicle manufacturer. These include resistor plug wiring, bonding straps, and bypass capacitors. Replace anything that doesn't look right.
2. Have the engine tuned by a good mechanic. This will not only eliminate some of the interference, but will give you better engine performance.
3. Connect the radio or tape deck directly to the battery through the proper in-line fuse.
4. Route all new wiring away from other wires, especially high-voltage ignition wires, **THIS IS IMPORTANT!**
5. Make certain the antenna lead-in wire shield is properly grounded at each end. All connections must be clean, tight, and properly soldered.

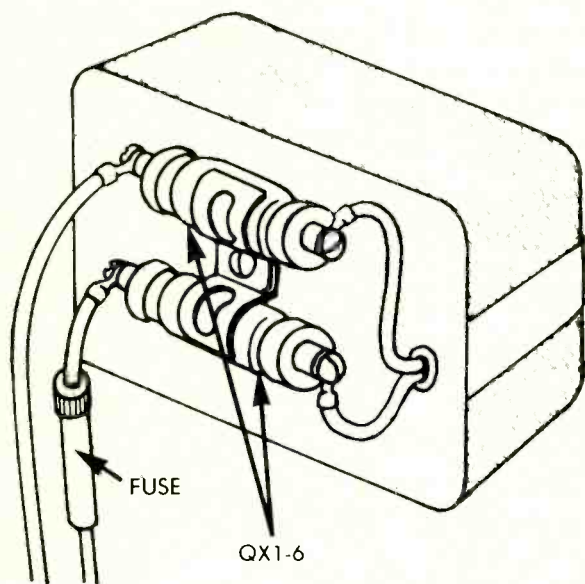

Figure 1A

Filtering the power line

To suppress radio-frequency noise, which is usually the most troublesome for CB and other AM radio installations, mount a general-purpose $.1\mu\text{F}$ @ 400 VDC,

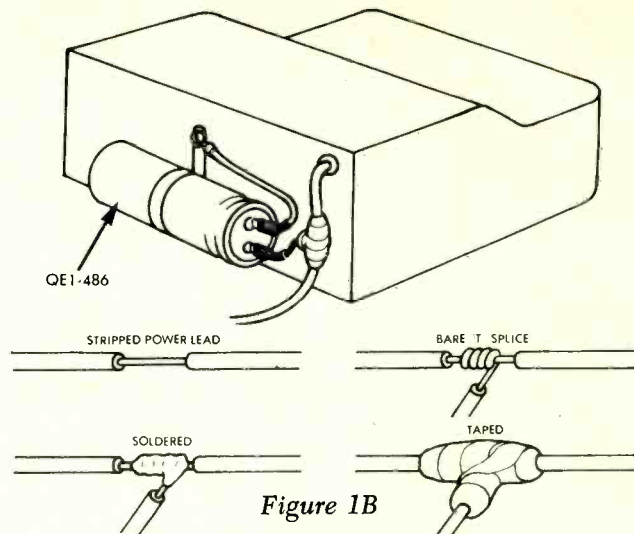

Figure 1B

20-amp feed-thru filter capacitor (Sprague Type QX1-6) on the back of the radio chassis, as shown in Figure 1A. Cut it into the power line as close as possible to the radio. If there is more than one power lead, install the filter in the lighter-gauge lead first. If noise persists, install a second filter in the remaining lead.

Audio-frequency noise, especially in tape decks and AM/FM receivers, can be just as annoying and troublesome. In these situations, connect a $200\mu\text{F}$ @ 200 VDC electrolytic filter capacitor (Sprague Type QE1-486) to the power line as closely as possible to the cabinet, as shown in Figure 1B.

With negative-ground electrical systems, connect the black lead to the tape deck cabinet, and the red lead to the power line. With positive-ground electrical systems, ground the red lead and connect the black lead to the power line.

Filtering the ignition coil

Mount a general-purpose $.1\mu\text{F}$ @ 400 VDC, 20-amp feed-thru filter capacitor (Sprague Type QX1-6) as closely as possible to the ignition coil, as shown in Figure 2. Don't mount the filter on the engine block. Disconnect from the coil the wire which leads to the ignition switch. Connect this wire to one end of the

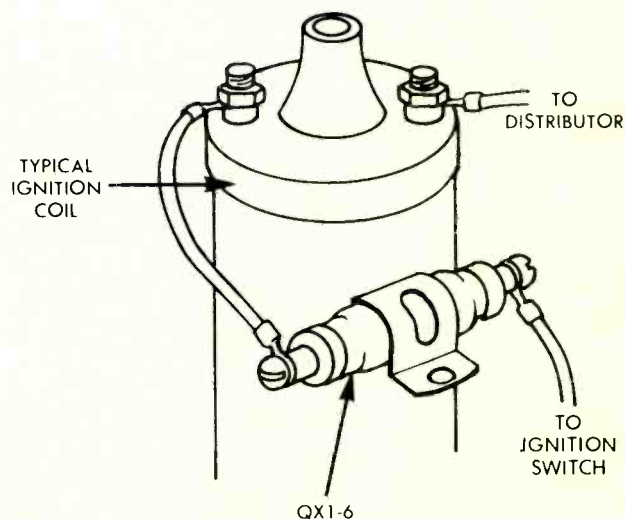

Figure 2

filter capacitor. Install a jumper wire using the same size and type of wire, from the remaining end of the filter to the coil terminal from which the wire was removed.

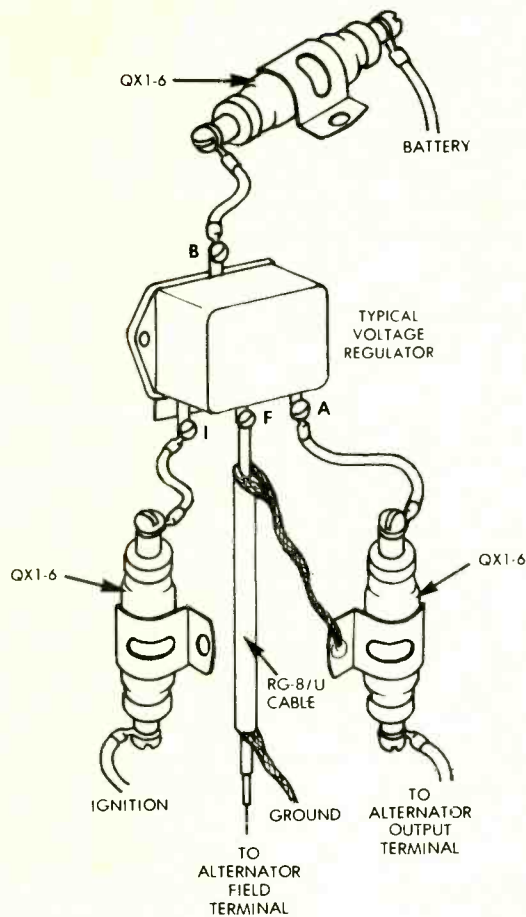

Figure 3

Filtering the voltage regulator

For vehicles with plug-in type electrical connectors, check with your auto mechanic for proper wire identification.

Mount a general-purpose $.1\mu\text{F}$ @ 400 VDC, 20-amp feed-thru filter capacitor (Sprague Type QX1-6) as closely as possible to the voltage regulator, as shown in Figure 3. Disconnect the wire from the terminal marked "I" or "ignition", and connect it to one end of the filter capacitor. Install a jumper wire, using the same size and type of wire, from the opposite end of the capacitor to the "I" terminal.

If noise persists, disconnect the wire from terminal "A" (armature) and connect it to one end of a second filter capacitor. Install a jumper wire from the opposite end of the capacitor to the "A" terminal.

If noise persists, disconnect the wire from terminal "B" (battery) and connect it to one end of a third filter capacitor. Install a jumper wire using the same size and type of wire, from the opposite end of the capacitor to the "B" terminal.

If regulator noise still persists, replace the wire from Terminal "F" with Type RG-8/U coaxial cable, grounding both ends of the braided "shield" portion of the cable to the chassis or nearest grounding point other

than the engine block. Be certain that the cable does not touch the engine block or any other accessory which may become hot during operation.

WARNING: Do not install any filter device on the terminal marked "F" or field. Permanent damage will result if this terminal is filtered or by-passed.

Filtering the alternator or generator

For standard alternators and generators, use a $.5\mu\text{F}$ @ 50 VDC 40-amp feed-thru filter capacitor (Sprague Type QX1-18). For heavier-duty alternators, use a $.5\mu\text{F}$ @ 50 VDC 40-amp feed-thru filter capacitor (Sprague Type QX1-100). For heavy-duty truck alternators, use a $.5\mu\text{F}$ @ 600 VDC 100-amp feed-thru filter capacitor (Sprague Type QX1-500), or a $.5\mu\text{F}$ @ 600 VDC 200-amp feed-thru filter capacitor (Sprague Type QX1-600).

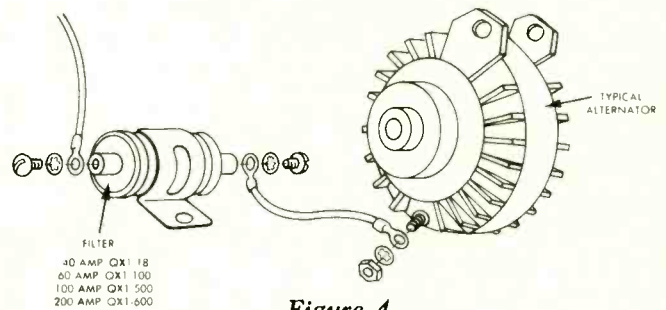

Figure 4

Mount the filter capacitor as close as possible to the alternator or generator, as shown in Figure 4. However, do not mount it on the engine block. Disconnect the wire from the output terminal on the alternator or generator and connect it to one end of the filter capacitor. Install a heavy jumper wire from the other end of the capacitor to the alternator output terminal.

Additional auto noise suppression measures.

Additional suppression steps can be taken at the terminals of such devices as the ammeter, oil pressure gauge, engine temperature gauge, and fuel gauge. It may even be necessary to suppress noise caused by the wiring at the dome light, trunk light, and instrument panel lights. In such cases, a general-purpose $.1\mu\text{F}$ @ 400 VDC, 20-amp feed-thru filter capacitor (Sprague Type QX1-6) should be located as close as possible to the offending accessory, or where its lead wire passes through the engine compartment firewall.

Grounding the exhaust end of the tail-pipe can reduce re-radiated interference. Such grounding can be accomplished by using a length of braided grounding strap.

For severe cases of ignition noise, before you resort to complete ignition system shielding, try the following less-expensive alternatives first:

1. Use resistor-type spark plugs, *after* you have checked with your auto mechanic. These plugs are

not to be used with capacitor discharge ignition systems.

2. Investigate the use of bonding or jumper straps, especially between the engine hood, fenders, engine block, alternator frame, and tail-pipe.

3. General-purpose $.1\mu\text{F}$ @ 400 VDC, 20-amp feed-thru filter capacitors (Sprague Type QX1-6) will often eliminate intermittent noise from turn signal flashers or windshield wipers by installing them at the terminals of the offending devices. NOTE: Feed-thru filter capacitors will have *no effect* on wiper motor noise, or signal fading, where the auto radio antenna is embedded in the windshield.

Automotive noise suppression requirements will vary with different vehicles, engines, and accessories. It is not possible to prescribe pat cure-alls for all noise problems. Each must be considered a custom case, with solutions for that particular car only. However, the information in this article should give you a good step forward in the suppression of noise for most of your specific problems. It remains for you to put the finishing touches to the job.

Boats and aircraft

Since electrical systems, power sources, and accessories in boats and airplanes are substantially more varied than those found in automotive vehicles, it would be extremely difficult to even generalize on procedures for noise suppression. It is suggested that you consult with your marine or aviation serviceman to determine the best approach and solution to your particular noise problems. Note that in the case of

aircraft, a certified, licensed mechanic must be employed. It is always best to check with your dealer.

Filtering at Power Cord of A-C Radios

CAUTION: Before doing any work on A-C line operated equipment, Pull the Plug!

If your fixed-station radio rig is used in a properly-grounded electrical system (a 3-wire 110 volt a-c system, a system using BX cable in good condition, or a permanent chassis-to-ground system), an a-c power line filter with a dual 3-amp rating @ 250 VAC/60Hz (Sprague Type QX1-03) may be installed in your radio to suppress line interference, as shown in Figure 5. Remove the line cord from the a-c receptacle and discharge any filters or bypass capacitors connected across the line cord.

Disconnect the line cord from the terminal strip, fuse holder, transformer, etc. Remove any bypass capacitors (usually disc ceramic capacitors) connected across the line cord or connected between the line cord and the chassis ground. Install the filter so that its lead wires reach the points where the line cord was originally connected. Connect the original line cord to the lug terminals of the filter.

CAUTION: When servicing equipment in which a line filter has been installed, always remove the line cord from the receptacle before removing the ground connection. Conversely, always connect the ground line before plugging the cord back into the receptacle.

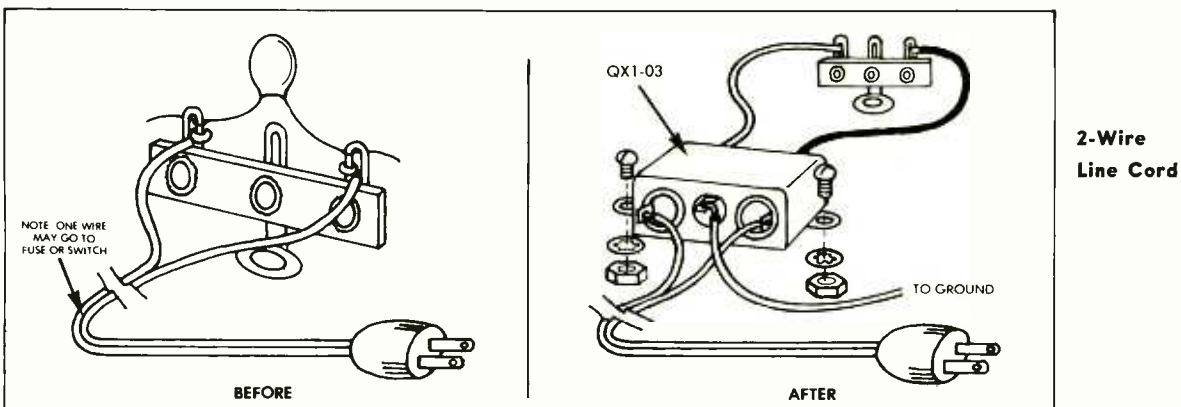
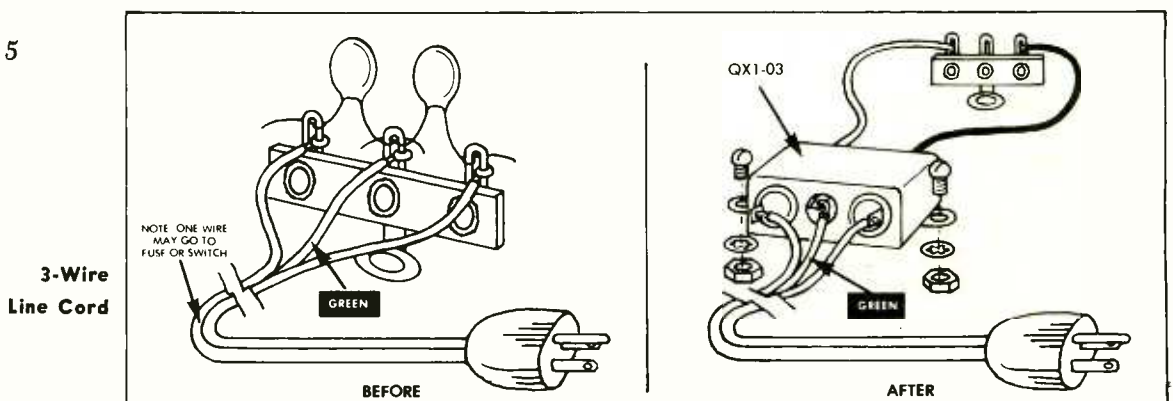
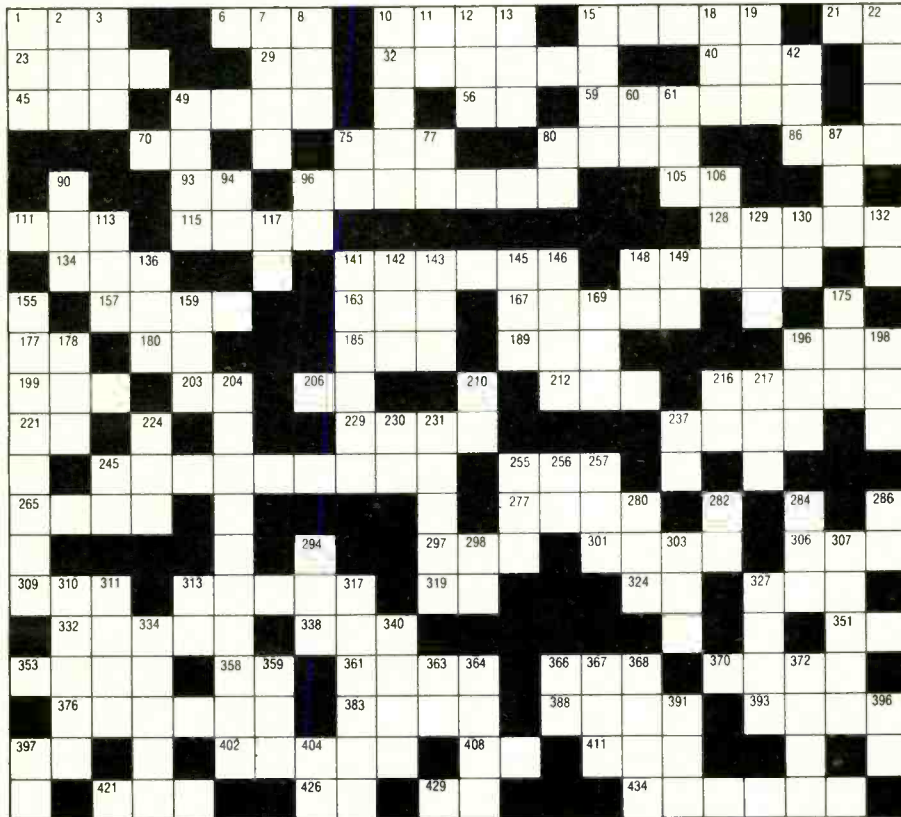

Figure 5



puzzle **ET**

OUR ELECTRONIC BRAINTEASER OF THE MONTH



Across

1. Turntable speed
6. Card acknowledging receipt of transmission
10. Opposite of space in RTTY
15. Measure of power
21. Measurement of sound level change
23. A bit of news
29. 1000 Hz (obs.)
32. Unit of current
40. 30-300MHz
45. 5-volt logic
49. Tube element
56. Belonging to me
59. Resistors can be hooked in parallel or in _____
70. Final amplifier in a transmitter
75. Motorola transistor numbering system
80. A unit
86. A thousand cycles per second
93. Integrated circuit
96. Another name for antennas
105. Silicon rectifier
111. If 110 is high voltage, 12 is _____ voltage
115. Kind of modulation popular with VHF hams
128. Operational amplifier
134. One who monitors foreign transmissions
141. Type of switch
148. NE555
157. Unit of electromotive force
163. Unit of resistance
167. Popular computer language
177. Any amateur radio operator (abbrev.)
180. Manufacturer of CBs, TVs and light bulbs (abbrev.)
185. Universal time (obs. abbrev.)
189. Reduced-carrier suppressed-carrier mode of transmission
196. Type of transistor
199. Part of radio you speak into
203. Flows in one direction
206. Prefix in coax numbering system
212. Meaning of radioman's "affirmative"
216. _____ modulation is pseudo-fm
221. _____-259

229. Phase-locked _____
237. To monitor several frequencies with same piece of gear
245. Electronic part
255. Fast-scan is _____
265. Vacuum _____
277. Only metal which magnetizes soundwaves
297. Personal receiver of mechanical soundwaves
301. Portion of electromagnetic spectrum
306. Film speed
309. "Say again please" (CW abbrev.)
313. Video tapes and video
319. Transmitters put out _____ energy
324. According to Ohm's Law, E = _____
327. Heath _____
332. Mel _____
338. Test instrument, measures current, resistance, voltage
351. Watts = _____
353. Radio-tv manufacturer
358. One logic device is an _____ gate
361. Pilot _____
366. Chases mice from ham shack
370. Manner of transmission
376. Panel _____ tell what's happening in your set
383. Tune in by turning the radio _____
388. Antennas often are made of _____
393. Light _____
397. _____ you were, men!
402. Hard iron
408. Light at a non-visible wavelength
411. Science fiction: _____ gun
421. One side of SSB
426. Other non-visible wavelength of light
429. _____ 58U coax
434. Contributing Editor Randy Patton's birthday comes _____

Down

1. Clarifier
2. _____ button on microphone
3. Our robot
7. Long distance radio propagation on shortwaves
8. Battery-saving readout
10. Another name for manufacturer

11. Mode of radio transmission
12. Measure of how fast your LP spins
13. Used to send Morse code signals
15. In ham lingo, W6 is on the _____ Coast
18. Unwanted disruption of home entertainment by a transmitter
19. Female pronoun
22. Alarm clocks _____
42. Radioteletype mode of operation
49. Transistor's beta is a measure of its _____
60. College major in electronics (abbrev.)
61. Term used in ac
75. Floats your balloon
77. _____ network
80. Sixth and seventh letters of name of simple emitter-base-collector semiconductors
87. Male pronoun
90. Well-known distress signal
94. World's largest two-way radio network
96. Ancient modulation
106. Semiconductor device which gives out stored information on command but won't take new data
113. Station which transmits time
117. Kind of broadcasts between 88-108 MHz
129. Twice the average dc power output
130. End of transmission (CW abbrev.)
132. Keystone State
136. SWL, ham or CB operations record
141. _____ switch
142. 19th Century German physicist
143. World time standard
145. Measure of weight (abbrev.)
146. This puzzle is _____
148. Invented the integrated circuit
149. Hundreds or thousands of transistors in one small package
155. Now you can own one of these
159. Bright red readout
169. Two-way radio manufacturer
175. Large industry convention
178. Some electronic gear is manufactured to _____ specs
196. Used to cool tubes
198. _____ little Indians

204. Devices for storing an electrical charge
210. Record
216. Board used to mount components (abbrev.)
217. Amateur radio operator
224. Five per foot
230. Turn the power _____
231. Different; additional
237. End of contact (CW abbrev.)
245. Channel 19 is in a _____ radio
255. Put your transmitter on the _____
256. Antenna and power switching relay in a two-way radio
257. Voice-controlled tape recorder or transmitter
280. Famous electronics home-study school
282. Please stand _____
284. Italian radio
286. One-thousandth of an Ampere
294. Kind of voltage from car battery
298. Receivers deliver this to loudspeakers
303. High-voltage _____
307. Stainless _____
310. You load information into these only once
311. Bass or treble
313. Make with _____
317. Lead and tin
327. Your stereo has a main-tuning _____
334. Groups of multiple bits in computer lingo
340. Reading the _____
359. Signal report (CW abbrev.)
363. Fractional measure of current
364. _____ in the tv
366. Transmission of International Morse code
367. _____ waves
368. Flat receptacle with raised edges for carrying things
372. Stereo requires _____ speakers
391. I would like an _____ ball contact with you
396. _____ line
397. opposite of dc
404. Power equals _____

STEREO CHORD EGG



*EGG - ENCEPHALO-GRATIFICATION GENERATOR

The EGG* plugs into any stereo amplifier to create soothing, flowing environmental sound textures - through headphones it's incredible. The chords and notes EXIST in your mind, they pan, swell and phase their way through your psyche in unpredictable patterns never repeating.

The combination of LSI organ technology with synthesizer-type processing and digital randomizing/control elements make the EGG an altogether intriguing package from either technological or metaphysical viewpoints.

The complete kit includes: circuit board, all parts and step-by-step instructions.

STEREO CHORD EGG KIT..... # 3790..... \$24.95 plus \$1.00 postage

another great kit from **PAIA**

() Send #3790 Chord EGG kit(s) at \$24.95 plus \$1.00 postage

name: _____

Address: _____

City: _____ State: _____ zip _____

() Send FREE CATALOG of other PAIA Kits. (405) 843-9626

PAIA ELECTRONICS • 1020 W. Wilshire Blvd. • Oklahoma City, OK 73116

CIRCLE 94 ON READER SERVICE CARD

WANTED

OLD LIONEL TRAINS

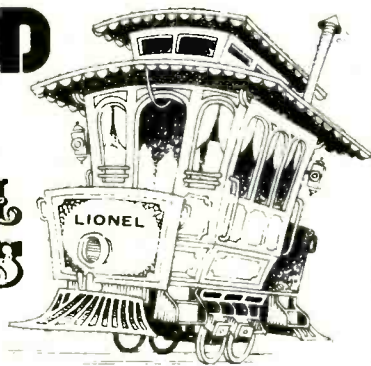

Especially pre-WW II "O" Gauge and Standard Gauge. Certain engine models are particularly needed. These are 5344, 700E, 763, 773 and 736. Also want 256, 260E, 255, 263, 752. Passenger cars bring good prices in excellent or better condition.

These trains will be for my personal collection. For that reason I can offer top cash or great swaps in radio equipment. Certain accessories bring mucho money. For example, the Lionel Industrial Power Station, Hell Gate Bridge, Scenic Park, etc.

I don't collect American Flyer or Lionel "O 27" gauge, but I will pay extra premiums for Ives models. Don't be bashful. Those old clunkers in your basement or attic will look great on my den walls.

Please write: **DICK COWAN**, Publisher ME
14 Vanderverter Ave., Port Washington, N.Y. 11050
Better still, call collect, if you're not certain what you have.
516/883-6200



Make \$ \$ \$ \$ \$ \$ \$ \$ \$ \$ \$ \$ in your spare time

modern electronics needs full or part time subscription salesmen

Because MODERN ELECTRONICS is the new magazine on the stands, it's got a sales potential of millions of hobby-oriented people. People like you who enjoy reading about all that's new in this dynamic field.

And if you like what you see in our magazine, you can be our best salesman. And that means lots of extra cash in your pocket.

The program is very simple. Simply sell charter subscriptions to MODERN ELECTRONICS to all your friends and neighbors at the bargain price of just \$9.95 for each one year sub.

Send in the subs to us, but keep a full \$2.00 commission on every sub you sell. To qualify as an ME salesman you need only send in five or more orders at any one time.

The magazine will sell itself. All you've really got to do is show it to your friends. The commissions you make can amount to really big cash.

Don't delay. Every day you waste is a day that could be bringing you big extra earnings.



Cowan Publishing Corp.

14 Vanderverter Ave., Port Washington, N.Y. 11050

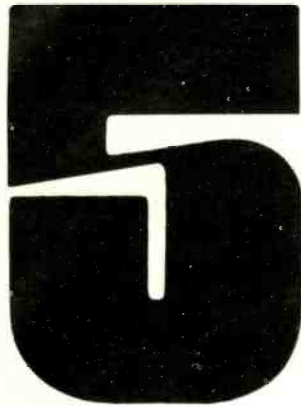

great reasons

why YOU should

subscribe to **CB RADIO**
(if you aren't already doing so!) AMERICA'S OLDEST AND LARGEST CB MAGAZINE

S9

- 1** You'll save a bundle. Newsstand copies are \$1.50 each, or \$18 for a year's supply. Your subscription costs only \$12 — that's 33% off!
- 2** You'll get S9 earlier. Subscriber copies will reach you as much as two or three weeks ahead of newsstand or store copies.
- 3** You'll be sure of getting your copy. Many times S9 is sold out before you can find it. Your subscription is like an insurance policy of fun reading.
- 4** You'll get a bonus. Right on! A 24 page copy of the FCC Part 95 CB regulations. The Commission charges \$1.25 for a copy, and it's a must for every CBer.
- 5** You'll make our editor very happy. And there's nothing more important than having a happy Tomcat (that is, if you're going to keep a Tomcat on the premises, as we do.)

So, indulge yourself. S9 is the CB magazine that doesn't quit when it comes to giving CBers all the scoop on what's happening out in the CB world. Do it now! Today! Before you forget!! After all, spreading joy is what CB's all about, now, isn't it?

Here's my \$12 for a 1 year sub,
..... \$20 for 2 years. This is a new
sub, or a renewal.

CB RADIO/S9

14 Vanderventer Avenue
Port Washington, New York 11050

Please include my FREE copy of FCC Part 95 CB Regulations

Name _____ Call _____

Address _____

City _____ State _____ Zip _____

Signature _____

Interbank No.		Exp. Date	
		Mo.	Year

BankAmericard Mastercharge

Note: Allow 8 weeks for delivery of first issue.

ME

news check ^{em}

STOP THE PRESSES: LAST MINUTE NEWS JUST IN TO MODERN ELECTRONICS

BY BOB MARGOLIN

COMPUTERS ARE TRENDING toward ready-to-run-when-you-take-it-home gear. Several plug-in-and-go types are on the market, along with many kits. Radio Shack has a ready-to-go computer, complete with video display under \$600. Sears hints at a test market for a \$600 set up during 1978. Atari, the video game people, Bally, the giant of pinball manufacture, PET and others are tooling up to ship micros to beginning-computer fans.

THE FCC CLAIMS to be stepping up enforcement activities. A recent sweep through high-problem areas resulted in hundreds of pink tickets. The best new tool in the Commission's arsenal is a highly-sophisticated transmitting-locating van. The direction finding gear in the truck displays the bearing, accurate to within one degree, of an illegal transmitter in less than one second! The FCC can easily pinpoint the location of a bootlegger within the time it takes the illegal operator to key his mic button.

STEREO BUFFS with fm receiver reception problems caused by signal ghosts have a new answer. BIC has a new Beam Box as a stereo accessory. It has an fm antenna inside which can be pointed electronically in any one of four directions selected from the front panel. A second front panel control lets you adjust antenna sensitivity to reduce the likelihood of your receiver being captured by strong stations on adjacent frequencies.

HAM RADIO operators around the world are excited about Russian and American amateur radio satellites. The two-way communications satellites provide world-wide talk power and are used by thousands of amateurs. The Russian bird is due any time and the U.S. OSCAR 8 will fly this spring. OSCAR 8 will replace the dormant OSCAR 6 which lost battery power last summer after years of valiant service.

HOME SECURITY with a complete tv system for \$425 is available in a new Sharp Electronics package. The three-piece outfit includes a two-pound camera, a 9-inch monitor and a two-way intercom with talk button. Power is in the 33 feet of cable and no ac installation is required. Sharp had been out of the home security business for years.

THE SHADOW KNOWS you have a radar detector in your car, but the cops don't. Shown at a recent auto accessory show, The Shadow allows you to tuck your present radar detector behind the front bumper/grill area. Shadow relays alarms to the driving compartment. Also seen at the show: Screw Ball, a ratchet screwdriver with two built in slotted bits and two phillips; Mr. Charge BC-1 battery charger which plugs into the 110-volt house power in your garage; and Fox, a high-performance two-band radar detector, also hides under the hood in grill.



The pick-up cost \$21,000.
The President SSB is somewhat less.

SSB (single sideband) is the most sophisticated form of CB.

And President may well have the most sophisticated form of SSB:

All new for 1978, it's called Adams.

It gives you more range and performance than any ordinary CB—with 12 watts of peak envelope power.

And it gives you a lot more ways to get the word out—with 40 upper sideband channels, 40 lower sideband channels and 40 AM channels.

And it gives you more ways to control the way the word

gets out and in than the average police radio—with 19 controls and switches covering every function.

And hear this:

Adams can keep an ear out for you on three channels at once—Channel 9 for emergencies, Channel 19 for the road, and the channel of your choice.

Now you may not want to spend \$21,000 for a pick-up.

But—for a mere 52nd of the cost—how can you pass up President's finest SSB Mobile?

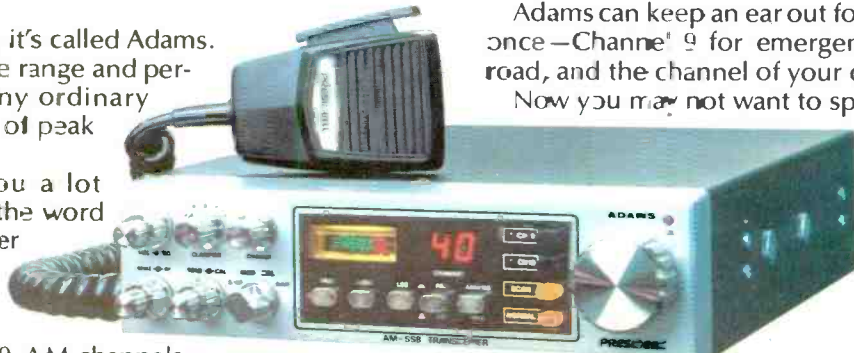

CIRCLE 6 ON READER SERVICE CARD

PRESIDENT

Engineered to be the very best.

President Electronics, Inc.
16691 Hale Avenue · Irvine, CA 92714 · (714) 556-7355
In Canada: Electron Radio Sales Ltd., Ontario

"...the Sansui tradition: solid, well thought-out...performance right up there with the best... a fine value..."

HIGH FIDELITY MAGAZINE*

If you're not yet convinced that Sansui receivers stand in a class by themselves, we'll try a different approach. Read what the editors say. After all, they're the experts.

"Here is yet another receiver in what we have come to think of as the Sansui tradition: solid, well thought-out...delivering performance right up there with the best...."

"Some 'extras' are immediately apparent when you lay an inquiring finger on the controls. The tone knobs are stepped...and include a MIDRANGE as well as the usual BASS and TREBLE...two phono inputs...mono mike input with its own mixing level control...There also is output-power metering...One special feature of the 7070 is its provision for outboard decoding of Dolby** FM broadcasts.

"The amplifier section is rated at 18dBW (60 watts) per channel and actually will pump out 1/2dB (10 watts) more before exceeding the distortion rating at any audio frequency. More impressive, harmonic distortion is far below Sansui's 0.3% rating at all tested power levels.... Intermodulation, too is low...."

"...If your expectations are high, there's very little about the 7070 that we think might disappoint you. Feel and finish of the parts is excellent, as we have come to expect of Sansui. The capable amplifier section has enough power for use with two pairs of speakers...the tuner section is among the best; the ancillary functions...are comprehensive and efficient. All in all, a fine value for the money."

See your local franchised Sansui dealer for a demonstration of the beautifully styled 7070, one of the only mid-powered receivers that offers twin power meters. You'll find that the experts are right. Musical quality is excellent and a finer value can't be found. It is what you've come to expect from Sansui.

A whole new world of musical pleasure.

*High Fidelity Magazine, Dec. '76 **Trademark of Dolby Laboratories, Inc. Simulated woodgrain cabinet.

SANSUI ELECTRONICS CORP.

Woodside, New York 11377 • Gardena, California 90247
SANSUI ELECTRIC CO., LTD., Tokyo, Japan

SANSUI AUDIO EUROPE S.A., Antwerp, Belgium • In Canada: Electronic Distributors

Sansui



CIRCLE 87 ON READER SERVICE CARD