

*San Francisco Brake*

# ELECTRICAL COMMUNICATION

*Technical Journal of the  
International Telephone and Telegraph Corporation  
and Associate Companies*

•

ELECTRIC TICKET-RESERVING SYSTEM  
AUTOMATIC SWITCHING IN PNEUMATIC-TUBE SYSTEMS  
MODERN TELEVISION-TUBE MANUFACTURE  
RHO-THETA SYSTEM OF AIR NAVIGATION  
MEDIUM-POWER TRAVELING-WAVE TUBE TYPE 5929  
AUTOMATIC SWITCHING OF TELEGRAPH MESSAGES  
PORTABLE MICROWAVE TELEVISION LINK  
FEEDBACK IN MAGNETIC AMPLIFIERS  
PHASE DISTORTION IN FEEDERS



Volume 27

DECEMBER, 1950

Number 4



# ELECTRICAL COMMUNICATION

Technical Journal of the  
INTERNATIONAL TELEPHONE AND TELEGRAPH CORPORATION  
and Associate Companies

H. P. WESTMAN, Editor

F. J. MANN, Managing Editor

J. E. SCHLAIKJER, Assistant Editor

## EDITORIAL BOARD

P. F. Bourget	H. Busignies	H. H. Buttner	E. M. Deloraine	W. Hatton	B. C. Holding
J. S. Jammer	E. Labin	A. W. Montgomery	E. D. Phinney	E. G. Ports	Haraden Pratt
G. Rabuteau	T. R. Scott	C. E. Strong	A. E. Thompson	E. N. Wendell	H. B. Wood

Published Quarterly by the  
INTERNATIONAL TELEPHONE AND TELEGRAPH CORPORATION  
67 BROAD STREET, NEW YORK 4, NEW YORK, U.S.A.

Sosthenes Behn, Chairman

William H. Harrison, President

Charles D. Hilles, Jr., Vice President and Secretary

Subscription, \$2.00 per year; single copies, 50 cents

Electrical Communication is indexed in Industrial Arts Index

Copyrighted 1950 by International Telephone and Telegraph Corporation

Volume 27

December, 1950

Number 4

## CONTENTS

ELECTRIC TICKET-RESERVING SYSTEM .....	251
<i>By W. R. Triem and J. S. Jammer</i>	
AUTOMATIC SWITCHING IN PNEUMATIC-TUBE SYSTEMS .....	260
<i>By Wolfgang Stieber</i>	
MODERN TELEVISION-TUBE MANUFACTURE .....	262
RHO-THETA SYSTEM OF AIR NAVIGATION .....	268
<i>By P. C. Sandretto</i>	
MEDIUM-POWER TRAVELING-WAVE TUBE TYPE 5929 .....	277
<i>By J. H. Bryant</i>	
AUTOMATIC SWITCHING OF TELEGRAPH MESSAGES .....	280
<i>By E. J. Agnew</i>	
PORTABLE MICROWAVE TELEVISION LINK .....	295
FEEDBACK IN MAGNETIC AMPLIFIERS .....	298
<i>By Alan S. FitzGerald</i>	
PHASE DISTORTION IN FEEDERS .....	320
<i>By L. Lewin, J. J. Muller, and R. Basard</i>	
IN MEMORIAM—SIR FRANK GILL, K.C.M.G., O.B.E. ....	324
FIFTEENTH PLENARY ASSEMBLY OF THE COMITÉ	
CONSULTATIF INTERNATIONAL TÉLÉPHONIQUE, PARIS, 1949 (CORRECTION) ....	294
RECENT TELECOMMUNICATION DEVELOPMENTS	
HIGH-FREQUENCY MEASUREMENTS CONFERENCE .....	319
FAHIE PREMIUM TO FLOWERS AND WEIR .....	319
400-KILOVOLT DIRECT-CURRENT TESTING EQUIPMENT .....	323
CONTRIBUTORS TO THIS ISSUE .....	326



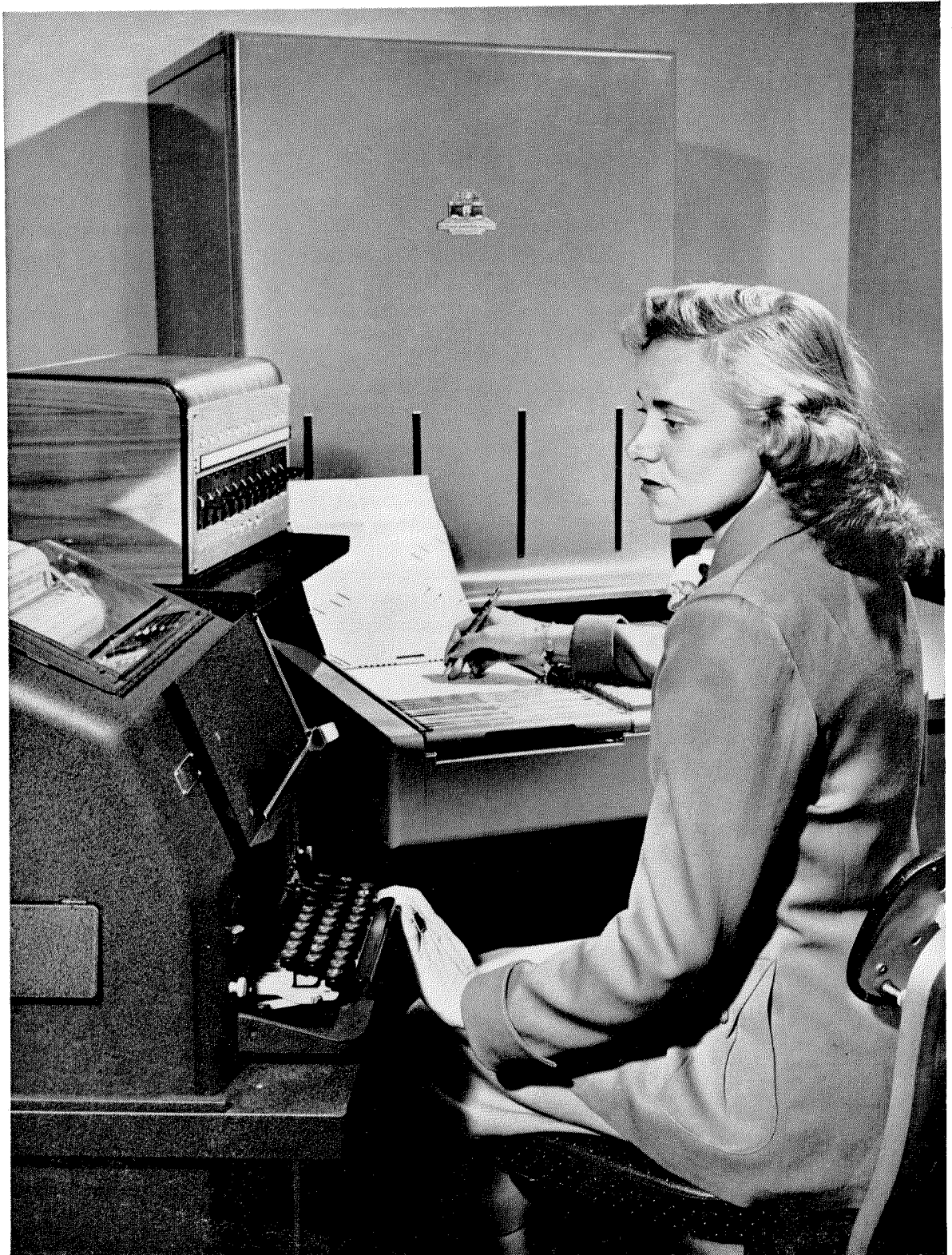

The space-control clerk in the Intelx system receives railroad reservations by teleprinter. An automatic switching system places the proper file before her for recording each reservation.

# Electric Ticket-Reserving System\*

By W. R. TRIEM

*The Pennsylvania Railroad Company, Philadelphia, Pennsylvania*

and J. S. JAMMER

*International Standard Trading Corporation, New York, New York*

STEADILY increasing difficulties have marked the expansion of the reservation systems of railroads and air lines over the past two decades. This may in large part be due to the greater number of people traveling today, to the increased speed of the vehicles, and perhaps also to the efforts that the carriers have made in supplying a large variety of accommodations. A large railroad can provide 12 different types of space such as berths, club chairs, roomettes, and so forth, all of which must be recorded in the reservation department to assure that every available seat is sold and at the same time to prevent duplicate selling that would irritate the passenger and endanger good public relations.

When it is realized that almost all of the many different types of accommodations can be had in a single train, and that for a number of weeks previous to the departure time the traveling public will be making reservations, buying tickets, cancelling reservations, and inquiring about available space, some idea of the complexity of the reservation records becomes apparent. The number of reservation transactions required to fill the cars of a typical train may approach 300.

The Pennsylvania Railroad over the years has maintained a manual reservation procedure at Pennsylvania Station in New York City and at six other major terminals. Clerks in the New York Bureau, for example, seated around movable files containing some 25,000 car diagrams, must manually select that particular diagram for the destination, day, train, and car for which an inquiry has been received, or on which a reservation or cancellation is to be recorded.

During the past few months, the railroad has been testing and installing at Pennsylvania

Station a new type of electromechanical automatic reservation system called *Intelex*,<sup>1</sup> a development of the International Telephone and Telegraph Corporation and its associate, the International Standard Trading Corporation. When the installation has been expanded to cover all trains leaving New York Terminal, it is estimated that a reduction of over 50 percent will be effected in the time required to cover a transaction relating to a reservation. Eventual expansion is planned by the railroad to cover all reservation handling over the entire system.

Before describing the Intelex system, it may be in order to give a brief description of the manual reservation procedure now used by the railroad.

## 1. Manual Reservation Handling

The basis of reservation recording for railroads is the car diagram, a card of heavy paper about 3½ inches wide by 12 inches long. On this card, in approximately the same position as on the actual railroad car, are marked spaces in which are entered the reservation information pertaining to each particular roomette or berth. Thousands of these cards are stored in movable files. An illustration of two of the types of files in current use is given at the right in Figure 1. In each of the files are stored the car diagrams for one section of the system for 60 days ahead. For instance, one of the top files in Figure 1 might be New York–Chicago trains; the next, New York–St. Louis, and so forth. Calls from ticket clerks and other railroad personnel are handled by automatic telephone switching through a private branch exchange, while calls from outside customers pass through clerks at a manual board.

<sup>1</sup> "Intelex" is a registered trade mark. See J. D. Mountain and E. M. S. McWhirter, "Intelex—Automatic Reservations," *Electrical Communication*, v. 25, pp. 220–231; September, 1948.

\* Reprinted from *Electrical Engineering*, v. 69, pp. 775–780; September, 1950.

A customer at a ticket window informs the ticket clerk of the date, train, and type of accommodation desired. The clerk then dials the proper telephone number and when one of the space-distributor clerks handling the file for that particular train is free, he will be answered. The ticket clerk then passes on the information, and the distributor picks out the proper set of diagrams from among

those in the file. Searching through the diagrams for this train, the distributor attempts to find a vacant space of the type requested. If successful, the ticket clerk is informed of the car and space numbers, which he enters on the customer's ticket; and in turn, the ticket clerk informs the distributor of the ticket number, which is duly entered on the car diagram. The customer then pays for the ticket and departs.

Should the customer have telephoned from his home or elsewhere, the method of handling is much the same. Instead of entering a ticket number on the car diagram, however, the customer's name is entered together with the time limit within which he must pick up his ticket at one of the ticket-selling points of the railroad. When the customer arrives at a ticket window, he informs the clerk of his name and the date, train, car, and space that was reserved for him. The ticket clerk then calls the distributor clerk and checks by having the clerk find the original transaction. If the information is correct, the ticket is sold and the distributor erases the customer's name and writes in the ticket number.

Should this customer decide to cancel his trip, he informs one of the railroad's agents of the day, train, car, and space number. This is passed along to the distributor and the previously entered information is erased from the car diagram.

About half an hour before train time, the diagrams relating to the train are removed from the

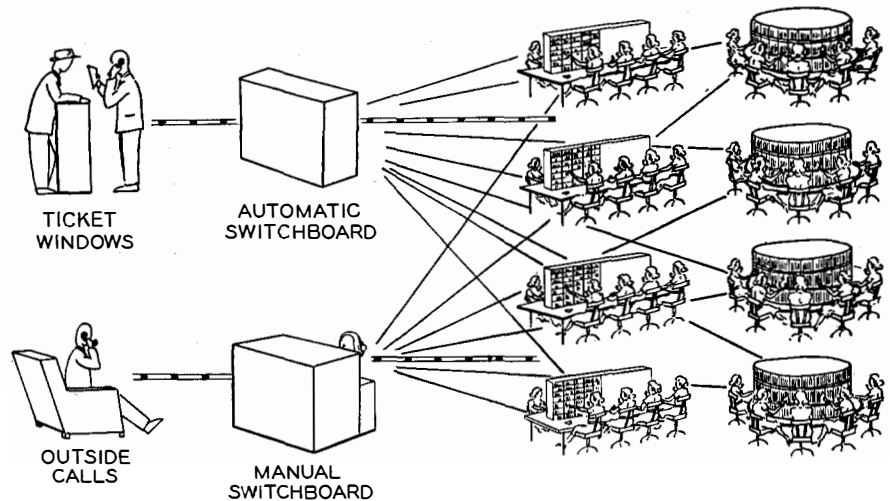

Figure 1—Manual reservations network in which customers and ticket clerks communicate by telephone with the distributor clerks at the files.

file, microfilmed for record purposes, and passed along to the conductor of the train so that he may check the travelers' tickets. An attempt is made at this time to sell any empty space on the train. As the trains depart, the spaces from which the diagrams were removed from the file are filled with a fresh set for the same train on the same section for a date 60 days ahead.

This, briefly, is the manner in which the present-day systems operate. In the busiest season at Pennsylvania Station, as many as 30,000 transactions a day have been handled by the 215 reservation people in the bureau. For the summer schedule, 79 trains comprising 427 cars leave the station daily, traveling to some 80 destinations with as many as 12 types of space—a total of 6,480 individual accommodations in 1,250 groupings of space and destination. This does not take into account such additional complications as are raised when extra cars are added to a train, or car substitutions are made.

In analyzing the manual method of handling reservations, it has been found that one of the main difficulties is the introduction of errors through misunderstanding of oral instructions, transposition of dates and numbers, and similar human factors.

Note that the only written records exchanged are the customer's car and space number that was written on his ticket by the ticket clerk and the ticket number written on the car diagram. Also, this information was exchanged orally.

On popular trains and on heavily traveled sections of the railroad, one distributor clerk may have to wait until another clerk finishes with the cards for a particular day and train before she can answer a request.

Again, as a particular train is approaching the date and time of departure, more and more requests for space on that train will be received. The distributor clerk must remove the appropriate diagrams from the file each time one of these calls is received, even though it is probable that no space is available.

## 2. General Description of Intelix

In the development of the Intelix system, elimination of all possible oral communication has been stressed. It may be noted by reference to Figure 2 that all communication, with the exception of calls from outside customers, is by means of teleprinters. This, in addition to minimizing the errors previously mentioned, has the advantage that printed records of all transactions are provided automatically.

The Intelix system may be divided into three interrelated parts: an availability service, a reservation service, and a ticket-information de-

livery service. In Figure 2, there is on each ticket clerk's desk an inquiry set, consisting of a telephone-type dial and a telephone receiver or loudspeaker. By dialing a code number, the clerk is connected through an automatic switchboard with one of a group of magnetic recorders. On each recorder, an announcer has placed up-to-the-minute information on the available space on trains departing for a single city on a certain day.

For the purpose of illustration, assume that a customer telephones the bureau to make a reservation. He will be connected with one of the telephone sales operators, who will use the inquiry service in finding suitable space. If the clerk finds accommodations that are satisfactory to the customer, he obtains the customer's name and the city ticket office at which he wishes to pick up the ticket. The clerk then turns to a teleprinter at his desk and types out a message of the following form:

**1824 6/25 29 AR NY-CHI 1604D3 CTA 6/17 JONES R.**

The first four digits of this series are a code in which 18 indicates that a New York-Chicago train is desired and the 24 indicates the date; second week from the current week, fourth day

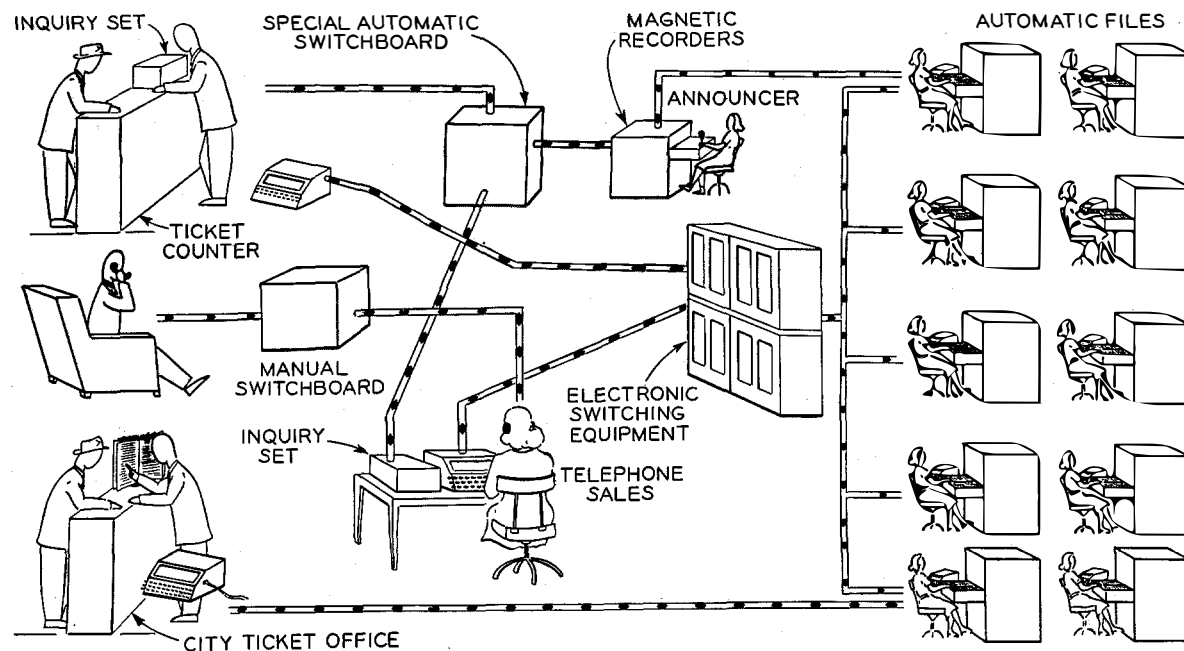

Figure 2—In the Intelix system, all communication is by means of teleprinters. The file cabinets automatically open the drawer containing the required diagrams so that the clerk can enter the information on them.

(Wednesday). This is the same code that the clerk uses for the inquiry service. The 6/25 is the date in un-coded form, a double check. The digits 29 indicate the train number (*Broadway Limited*), and the AR means one roomette (A = one, R = roomette). NY-CHI are the terminal stations for the trip, and 1604D3 is a composite serial number for the transaction in which 16 is the current day of the month, and 04D3 is the fourth transaction of clerk number D3 on that date. The CTA 6/17 JONES R. indicates that customer R. Jones has said he will pick up his ticket at city ticket office A by June 17.

As indicated in Figure 2, this message is transmitted through automatic switching equipment to a teleprinter beside one of the distributor clerks in front of the file cabinets. The first series in the preceding message 1824 enables the switching equipment to select cabinet 18. Each cabinet contains the car diagrams for all trains between two terminal points on the railroad system for 60 days in advance. At the same time as this message is being relayed on the teleprinter beside the distributor, the drawer corresponding to the second week, fourth day automatically slides out in front of the operator.

She then finds in this drawer the series of diagrams corresponding to train 29 and assigns a roomette to customer Jones, noting the serial number 1604D3 on the diagram. To validate this transaction, she will add to the end of the teleprinter message the code R9 W10, which means that Mr. Jones has been given roomette number 9 in car W10.

The complete message in this augmented form is then automatically transmitted back to the ticket clerk making the sale, whereupon Mr.



Figure 3—The announcer is making a new availability report that will be used for the inquiry service.

Jones may hang up his telephone. At the same time as the distributor clerk retransmitted the message to the ticket clerk, the same message was sent to city ticket office A, where Mr. Jones need only give his name to permit the clerk to find all the information required to complete the sale of the ticket without further reference to the reservation bureau.

If Mr. Jones had appeared at a ticket window, the procedure would be the same as that just described, except that the name of the customer is not recorded since the ticket is delivered forthwith.

Had this sale been the last roomette available on the *Broadway Limited* for June 25, the distributor clerk would also arrange to have this information automatically transmitted to the announcer at the availability service. This message is a signal that the recording for that train requires revision. A new recording is made

immediately, the previous one being erased automatically, so that the availability information is always kept up to date.

This Intelix reservation system, in addition to its elimination of human errors and the automatic provision of printed records in the station and at city ticket offices, has the advantage of speed. It is estimated that the time required for the machine handling of a reservation or cancellation will not exceed 30 seconds.

The operation of the entire system now having been described, some of the more interesting circuit features may be discussed.

### 3. Availability Service

The announcer for the availability service sits in front of a telephone-type switchboard on which are lamp and jack panels. A microphone is placed in front of her (Figure 3). When she receives information over her teleprinter that one of the recordings must be revised, she selects the magnetic recorder for that train by plugging into the proper jack on the panel in front of her. She then proceeds to record a completely new announcement to replace the previous information, which has been erased automatically. In the meantime, should any of the ticket clerks happen to dial for that record, they will hear instead a special recording saying that a new record is being made and will be available in a few seconds. When she disconnects, the new recording is available immediately.

These recorders (Figure 4) are of the magnetic type in which the recording material is on the surface of a cylinder. Maximum recording time is  $1\frac{1}{2}$  minutes, which is ample for the longest record. The recording and playback head is mounted on a carriage that travels across the surface of the cylinder. At the time that the operator plugs in the microphone, a bar magnet moves near the cylinder to erase the previous record. The recording head, as it advances, carries with it a small trip that is fastened at the exact spot at which the announcer stops talking. When the record is being played, this stop returns the playing

head to the beginning of the record automatically. Thus no time is lost by waiting for the entire  $1\frac{1}{2}$ -minute period to play through, yet each new listening starts from the beginning. Any number of clerks may be connected simultaneously to the same recorder.

When dialing over his inquiry set, the ticket clerk uses a 4-digit code such as 1824. In this code, the 18 indicates the section (such as the New York-Chicago section) and the 24 is a code indicating the date. If a standard 4-digit date code as is used in business were applied here, say for example 11/25, the amount of switching equipment that would be required to select the proper recorder would be increased enormously.

A calendar has been devised (Figure 5) in which the dates are divided into weekly periods. Indication of any date up to ten weeks in advance is thus possible by means of a 2-digit code. The inside slide of the calendar carries the dates and is moved up one line each week on midnight Saturday, so that the current week is always number 1.

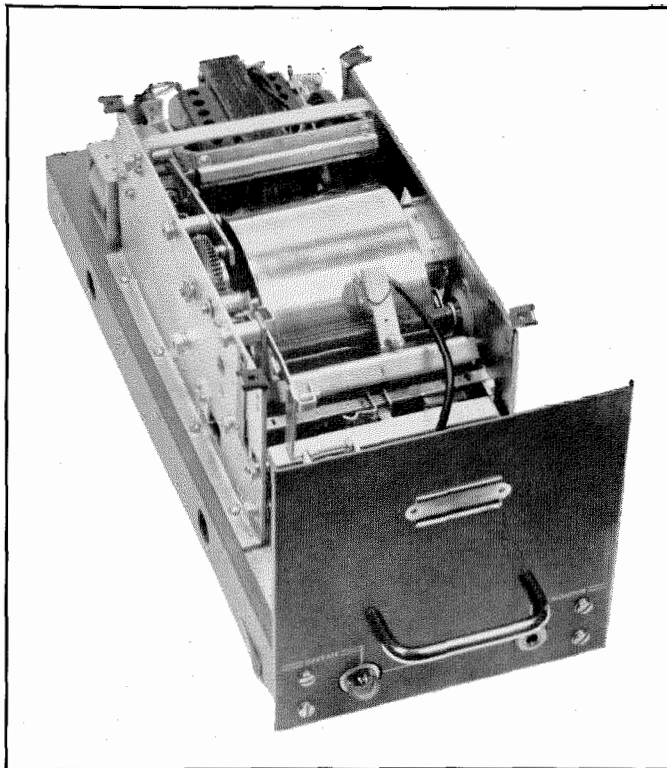

Figure 4—The availability information is recorded on a moving drum of magnetic material. The record is made so that it will repeat as soon as the recorded material is reproduced.



This means that the recorder containing the information for, say, August 17, may be reached this week by dialing 85, but next week, after the clerks move their calendars, they must be able to reach it by dialing 75. Therefore, a time-clock system is included in the switching mechanism to advance the third-digit selector switches by one digit each week.

**Intelex**  
**CALENDAR**

Displaying day of week.  
Valid for 70 days from starting date.

	Su.	M.	T.	W.	T.	F.	Sa.
	1	2	3	4	5	6	7
1—	June 25	26	27	28	29	30	July 1
2—	July 2	3	4	5	6	7	8
3—	July 9	10	11	12	13	14	15
4—	July 16	17	18	19	20	21	22
5—	July 23	24	25	26	27	28	29
6—	July 30	31	Aug. 1	2	3	4	5
7—	Aug. 6	7	8	9	10	11	12
8—	Aug. 13	14	15	16	17	18	19
9—	Aug. 20	21	22	23	24	25	26
0—	Aug. 27	28	29	30	31	Sept. 1	2

**Instructions**

To call for an Availability Record for any date:

DIAL section covering destination—then—

Dial	Week	number (vertical red column)
Day	number	(top red number)

Advance calendar midnight Saturdays so that  
Week No. 1 is current week.

\* Change calendar insert each tenth week.

Figure 5—The part of the calendar carrying the dates is moved up one line each week.

The recorders each can handle the information for all trains on a single day between two cities. Since reservations are made as far as 60 days in advance, this would mean that 60 recorders are required for each two terminal cities. However, since most of the reservations are made only about one or two weeks in advance, the full capacity of a recorder is needed for each day only for the 14 days preceding train departure. This requires 14 recorders. A full week is handled by each of the next two recorders and the balance of 32 or more days is put on a single recorder. This is a grade-1 rating. This same method of condensing the information is used where only a few trains travel over a lightly loaded route.

Under this system, the sections of the railroad are divided into groups requiring different grades of recorder service, and permit the number of recorders and the amount of switching apparatus to be reduced appreciably. It is estimated that 240 recorders will be in use when the installation at Pennsylvania Station, New York, is completed.

A diagram of the switching system used to route the ticket clerk's call to the proper recorder is given in Figure 6. In this switching circuit, telephone-type relays and step-by-step switches are used. To trace through the circuit, assume that the clerk at the inquiry set has just raised his telephone receiver. Immediately one of the line finders seizes his line. When he begins dialing, the first two digits, indicating the destination of the train, are absorbed by the connector switch. The first digit is used to select the proper destination switch, and the second marks the proper level on the destination switch.

The second two digits, representing the week and day of the requested information, are fed to the calendar translator, in which adjustment must be made for the grade of service (number of recorders) of the particular destination, and the daily and weekly change in the code with respect to the selection of the particular recorder. Since there are four different grades of service, the particular grade into which the destination falls must be taken into account in the translation of the date. The destination, and hence the grade of service, is indicated by the first two digits of the code.

Adjustment for the passage of days and weeks is made in the calendar translator by the clock

through the calendar control circuit. Daily adjustment is made at midnight. Therefore, when the second two digits of the code are applied to the calendar translator, the proper contacts on one of the levels of a single destination switch are marked. The destination switch then hunts for these contacts, and the through connection between the clerk's inquiry set and the proper recorder is completed. The recorder then starts, and the availability report is heard.

night, but before the announcer has revised the record, will be connected to the proper recorder, and not to the recorder holding the information that has already expired.

#### 4. Reservation Recording System

By means of an electromechanical switching system, the teleprinters of the ticket clerks are connected to the teleprinter and automatic file

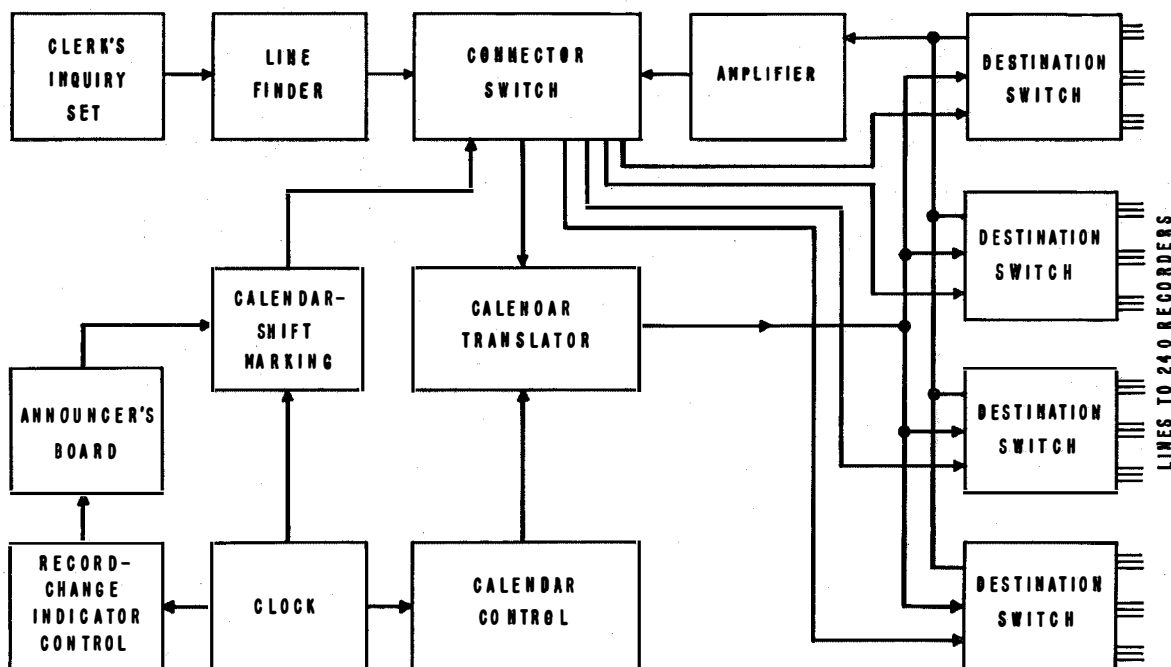

Figure 6—Block diagram of the switching circuit for the availability service.

The clock circuit also controls the record-change indicator control. This circuit, which operates at midnight daily, lights a signal lamp on the announcer's switchboard over each jack that connects to an out-of-date recorder. The announcer then knows that the information on these recorders, which contained the records for the day that has just passed, must be erased and new information recorded for some future day. By tearing off a small paper tag mounted just above the jack on the board, she will see indicated there the particular section and day for which the availability should be placed on the new record.

The calendar-shift marking circuit is installed so that a ticket clerk who might call after mid-

cabinet of the proper space-distributor clerk (see frontispiece). The teleprinter is at the clerk's left. Since she types only 4 to 6 digits and letters in confirming a reservation, it need not be in front of her. In a large file cabinet are 60 drawers in which are filed the diagrams for all trains between New York and Chicago for 60 days from the current day.

By decoding the first four digits of the ticket-clerk's message, the equipment automatically selects and moves the proper drawer in front of the clerk. In this drawer, the diagrams are arranged in groups representing the various trains leaving that day. The diagrams are so designed that when all of a certain type of space has been sold on one train it will be apparent immediately,

and the inquiry service announcer may be informed of this change in availability status.

Also visible in the picture, above and to the right of the teleprinter, is a small box mounting a key panel. When the clerk has confirmed a message by addition of the car and space number, she presses a button, which causes the drawer to slide back inside the file cabinet, and the completed message is transmitted to the ticket clerk. By depressing one of the keys on this keyboard, the distributor may also select certain other places to which the message is sent simultaneously. These include the various city ticket offices, the announcer of the inquiry service, and a monitoring supervisor.

Since the code dialed to reach the specific drawer in the proper file cabinet is exactly the same as that used for the inquiry service, it is apparent that the same form of calendar-adjust-

ing device must be used to allow for the changing week numbers. Also, since the 4-digit code number is transmitted in the 5-unit teleprinter code, some form of recoding device must be included.

A block diagram of this switching and storage circuit is given in Figure 7. In the box in the upper left corner are the transmitting and receiving teleprinters in the ticket clerk's office. Separate teleprinters are used for these two functions because more rapid operation is possible. One set of such instruments will take care of the traffic of several ticket clerks. At the start of transmission, connection is made through a line finder to a storage and distribution circuit and also to an electronic translator. In the storage unit, the entire message is punched in tape by an instrument combining a typing reperforator with a tape transmitter. Both the reperforator and transmitter in this teleprinter are mounted in the

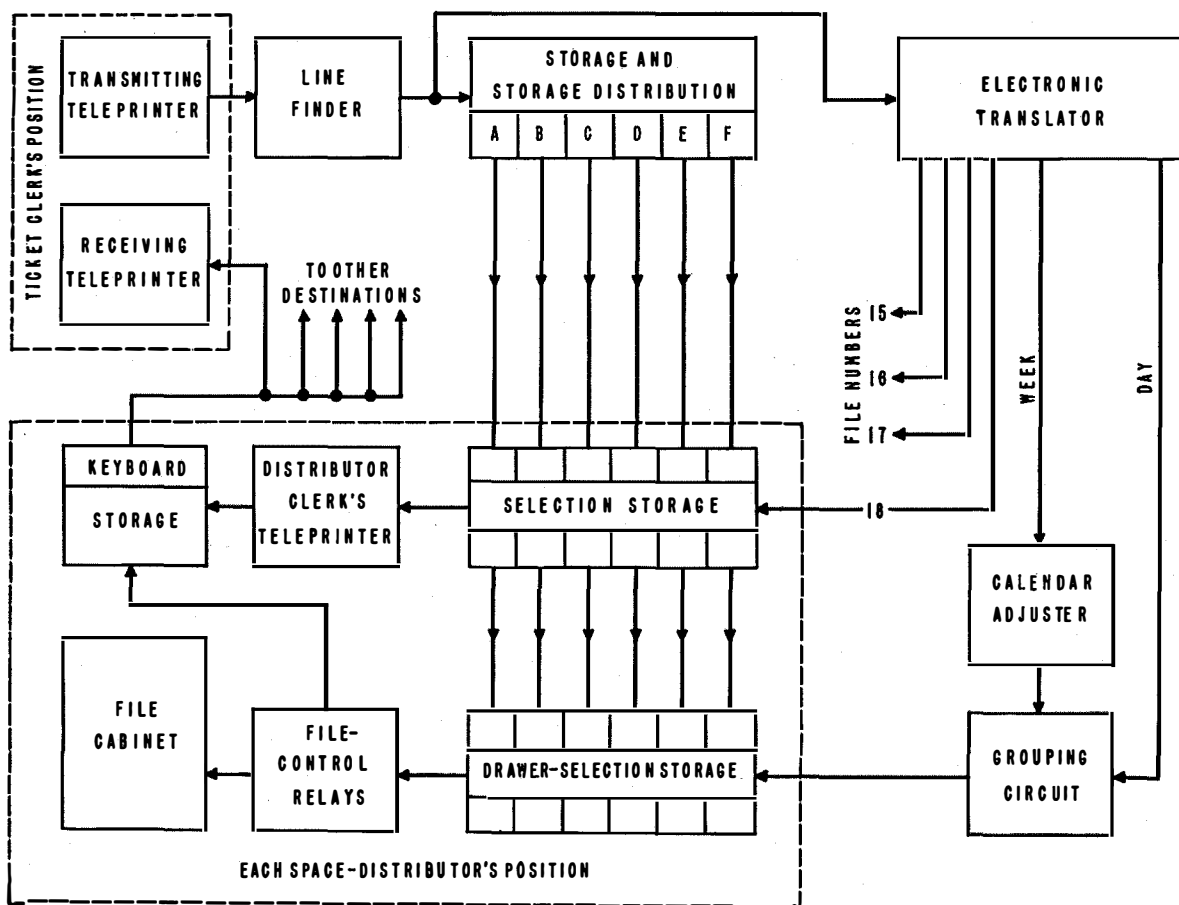

Figure 7—Block diagram of the switching system for the selection of the proper file and drawer at a distributor position. Switching and storage circuits use telephone-type relays and step-by-step apparatus.

same instrument, and the transmitter is so arranged that the transmitting head will advance along the tape toward the punching head so it can transmit the very last character punched in the tape. Storage space is provided for punched tape in case the transmitting function is held up while messages are still being received.

Then, the entire ticket clerk's message is stored in the tape of one of the teleprinters *A . . . F*, while the first four digits of the message containing the code for the file cabinet corresponding to the section of the railroad and the day of the requested reservation are fed to an electronic translator. This device consists of a group of gas-tube counting chains and storage relays so arranged as to decode the 5-unit teleprinter code and provide the file number, week, and day of the message in usable form.

Since only a weekly change in code number is required, the calendar adjuster is very simple; it consists of a slip-multiplied stepping switch moved once a week by a clock. Combination of the week and day information in the grouping circuit provides the information as to which drawer in any cabinet contains the car diagrams for the desired day. There are 60 drawers in each of the cabinets, and they are all similarly arranged as to the day involved.

The electronic translator activates the selection-storage circuit of file cabinet number 18, should that have been the one requested, and the number of the requested drawer is transferred into the drawer-selection storage circuit of this cabinet. It may be mentioned here that in the translation of the teleprinter code, the selection of the desired cabinet, and the storage of the information in the circuits of the cabinet, only about one second is required. Hence, the message capacity of the translator circuit is approximately 3,000 per hour. The equipment may be multiplied if greater traffic is expected.

In effect, the storage circuits of cabinet 18 have now been informed that there is a message waiting on say, storage unit *E* of the storage and storage-distribution circuit and the drawer number pertaining to that message. If there is an unanswered message yet on the distributor

clerk's teleprinter, this information will be stored until the preceding message is answered. This permits stacking of messages in each space-distributor position. If there is unanswered traffic at any file, a lamp is lighted above the position to attract attention.

When the distributor clerk's position is free of unanswered traffic, the message on storage unit *E* is transferred to the distributor's teleprinter and at the same time the file-control relays cause the proper drawer to move out of the cabinet. While the message is being transferred to the distributor's teleprinter, it is also punched in the tape of another storage reperforator-transmitter. When the distributor confirms the reservation or cancellation by typing four digits at the end of the message on her teleprinter, these are also punched in the tape in the storage unit.

After the clerk has completed all action on the message, she will depress one or more keys on the keyboard and will push the start button. Then, the drawer will return into the file and, at the same time, the complete message will be transmitted from the tape of the storage unit to the ticket clerk's receiving teleprinter and also to such other places as may be required.

## 5. Conclusions

The Intelix reservation system will provide a greatly increased efficiency in the handling of reservation traffic. In addition to speed of operation, it provides for the automatic provision of printed records of all transactions and reduces to a practical minimum all manual operations.

It is aimed at separating the process of answering the customer's questions as to what space is available from the process of actually entering the sales on the car diagrams, and accomplishes this without losing the personal touch. Under the manual system, these two processes were inseparable, resulting in clerks' waiting for each other to release diagrams. At times of busy traffic these conditions tended to snowball, and it is in these busy times that Intelix will show the greatest benefit to both the traveling public and to the railroad personnel.

# Automatic Switching in Pneumatic-Tube Systems

By WOLFGANG STIEBER

*Mix and Genest Aktiengesellschaft, Stuttgart, Germany*

**P**NEUMATIC TUBES provide a simple, convenient, and effective method of transporting written messages and relatively small packages over short distances. If just two places are to be interconnected, a simple two-tube installation will suffice. If, however, there are a multiplicity of stations and if each must have access to every other station in the system, the need for directing the carriers to the desired destination presents a serious problem.

As in almost all fields of technology, the easiest solution of a problem of this nature is to use an operator who, in this case, sorts the carriers by color or some other method permitting rapid identification and manually transfers them to the designated outlet.

Manual operation is satisfactory for many installations but in addition to requiring an operator on duty during all times when the system is in use, it is also necessary that each station be connected directly with the central distributing point by two tubes, one for each direction of travel. Where several stations are near each other and are also at a substantial distance from the

central distributing point, an arrangement permitting these stations to share a common tube, analogous to the party line in telephony, would reduce the amount of tubing needed.

A fully automatic switching system has been developed that can handle up to several hundred stations. As in the manual system, there is a central switching point through which all carriers must pass. A single loop of tubing to this central point can, however, handle as many as 10 stations.

In this system, the carrier, similar to that shown in Figure 1, has a number of metallic bands distributed along its length. The bands are electrically insulated from each other. At one end are two wider bands that may be rotated by hand to bring numbers marked on them to an indexed position, thus identifying the number of the station to which the carrier is to be transmitted.

When the carrier is inserted in the tube, it is transported by a moving column of air to a switching center of the type shown in Figure 2. Any number of carriers may be put into the tube at various stations on a single line for passage to the switching center, where each one is stopped for a moment while a set of electrical contacts touch the conducting rings on the carrier. The setting of the numbered rings determines which of the relays shown in Figure 3 will be activated to control the movement of the carrier to its indicated destination.

The relays having determined that no other carriers are in transit, selectively open only that receiving position to which delivery is to be made. The carrier then passes into the proper outgoing tube and is sent to its destination. On

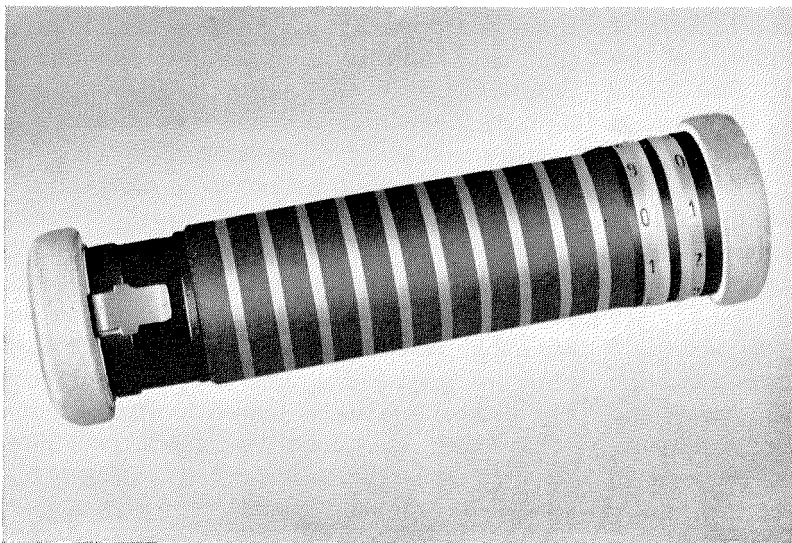

Figure 1—The standard type of cylindrical carrier is provided with 10 contact rings and two numbered rings that may be rotated to identify to the automatic switching mechanism the station to which the carrier is addressed.

arrival, the relays are released and the line is once more available for another delivery.

If the carrier has been put into the tube with the front and rear ends reversed or if the numbered rings have been set for a nonexistent re-

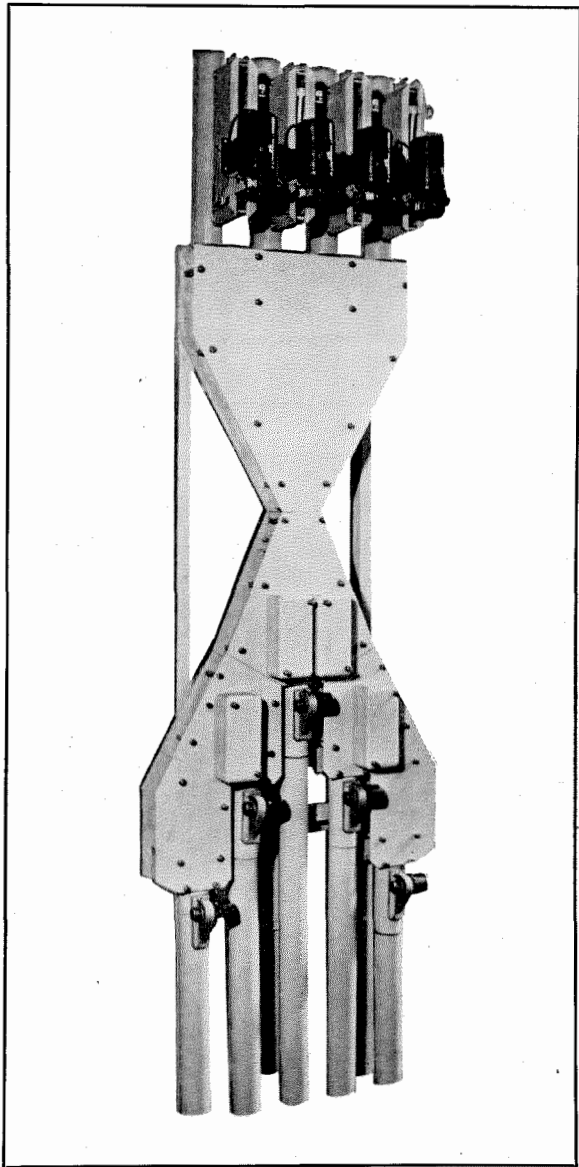

Figure 2—A four-channel automatic switching mechanism. The carrier to be distributed enters one of the tubes at the top where a series of contacts touch the rings on the carrier. The carriers are delivered to the appropriate tubes at the bottom for the completion of their journeys. The fifth tube at the bottom is for rejected carriers; those that are misdirected to nonexistent stations or are inserted in the tube wrong end to.

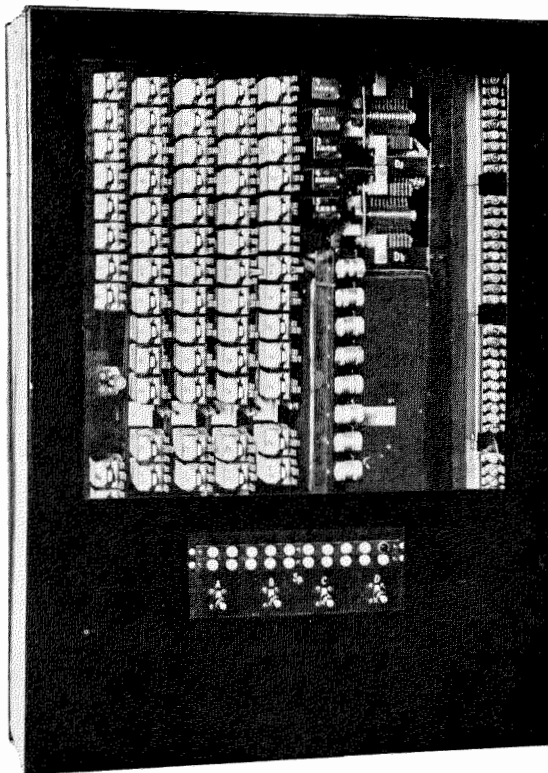

Figure 3—Relays are actuated by the contact fingers that touch the rings on the carriers. In turn, the relays control the various electromechanical devices associated with each station to select the delivery point.

ceiving station, the carrier will be discharged into a "reject" tube at the switching center and an alarm bell and light will announce the inability of the system to determine its destination. These errors are so few normally that the telephone operator, or someone having a similar type of duties, can make the necessary corrections without seriously interrupting her regular work.

A switching center using six lines is capable of servicing 60 stations and can handle up to 1200 carriers an hour. Both larger and smaller installations are practical. It is also possible to interconnect several switching centers by trunk lines.

This development in automatic switching of pneumatic-tube carriers was made by Mix and Genest, an associate of the International Telephone and Telegraph Corporation.

# Modern Television-Tube Manufacture

**A** PHOTOGRAPHIC series is presented here of the television cathode-ray-tube assembly line of Federal Telephone and Radio Corporation at Clifton, New Jersey. At the right is a 16-inch rectangular tube, one of the several types currently in production. All of the more popular sizes of round and rectangular tubes can be assembled on equipment especially designed to permit ready conversion to different types and sizes of tubes. The assembly line is arranged roughly in the shape of a giant circle, both the beginning and end of the line being situated at the shipping and receiving department of the factory. The component parts of the tubes are manufactured elsewhere.

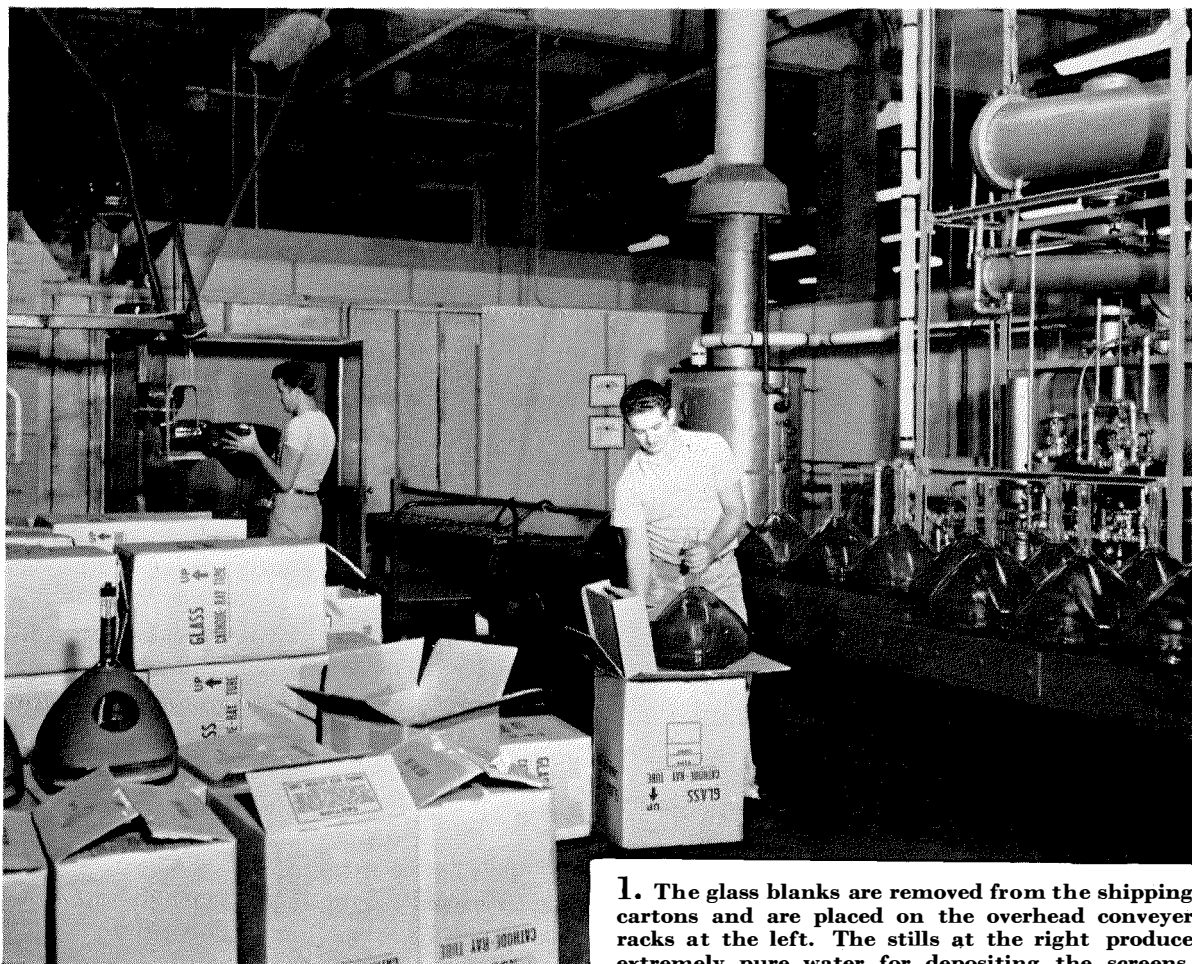
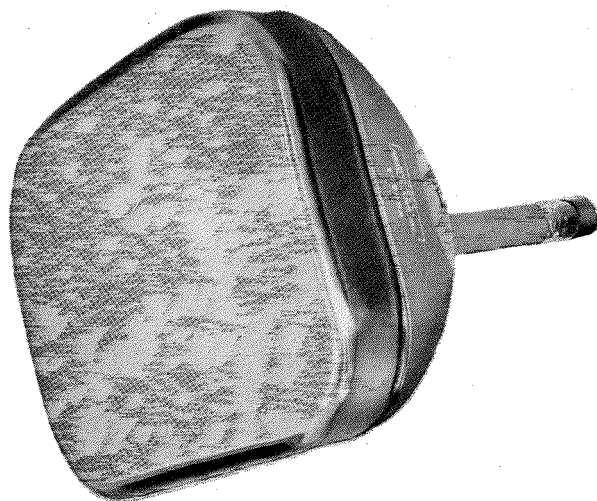

1. The glass blanks are removed from the shipping cartons and are placed on the overhead conveyer racks at the left. The stills at the right produce extremely pure water for depositing the screens.

**2.** The washing process includes cleaning of the inside of the blank with acid and two rinses with distilled water. The machine is operated automatically, requiring only loading and unloading.

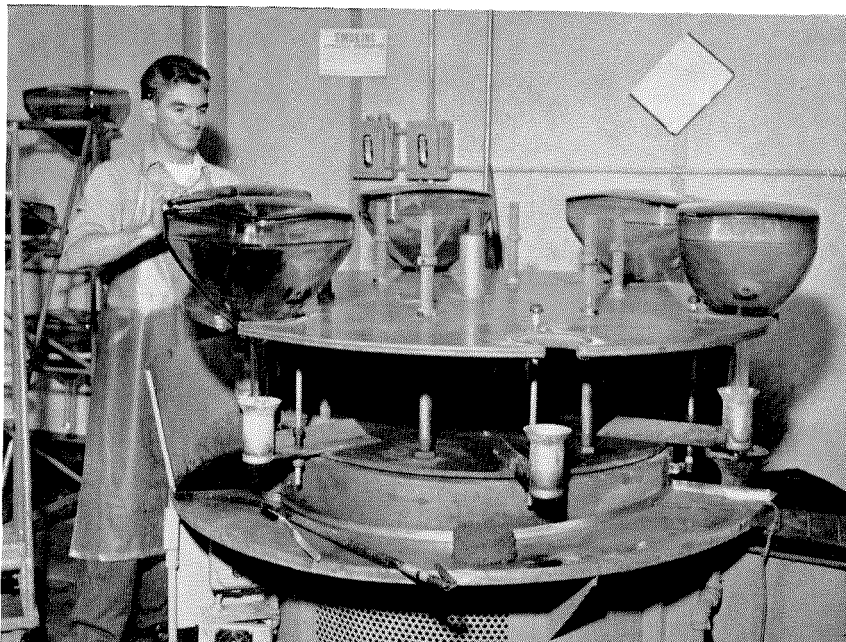

**3.** The phosphor is settled out of water to form the screen of the tube. The settling table then slowly tilts, pouring off the water without disturbing the screen. The screen is dried on the table at the right with a flow of hot air.







4. The inside aquadag coating is applied to the tube while it rotates on a stand. A small brush on the end of a long handle is used to apply the coating, which is in semiliquid form and must then be dried.

5. The screen and aquadag are dried in this large gas-fired oven. The tubes placed on the rotating table are brought up to the desired temperature and then slowly cooled. The fluorescent screen is next inspected under ultraviolet light for defects.

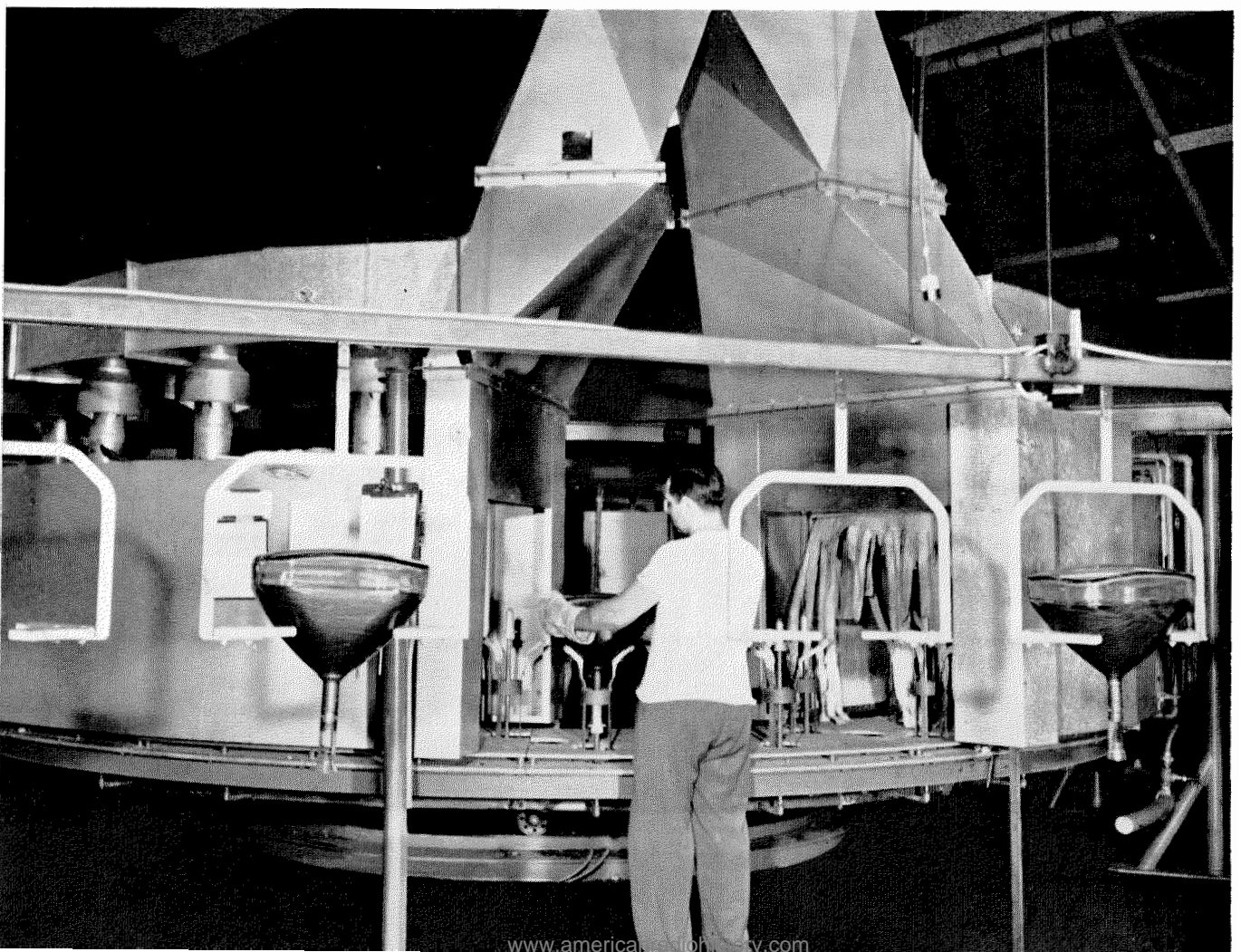

6. On this revolving table, the necks of the tubes are heated, the preassembled electron gun is sealed in, and the necks are annealed. The tubes are rotated rapidly on their axes during this process.

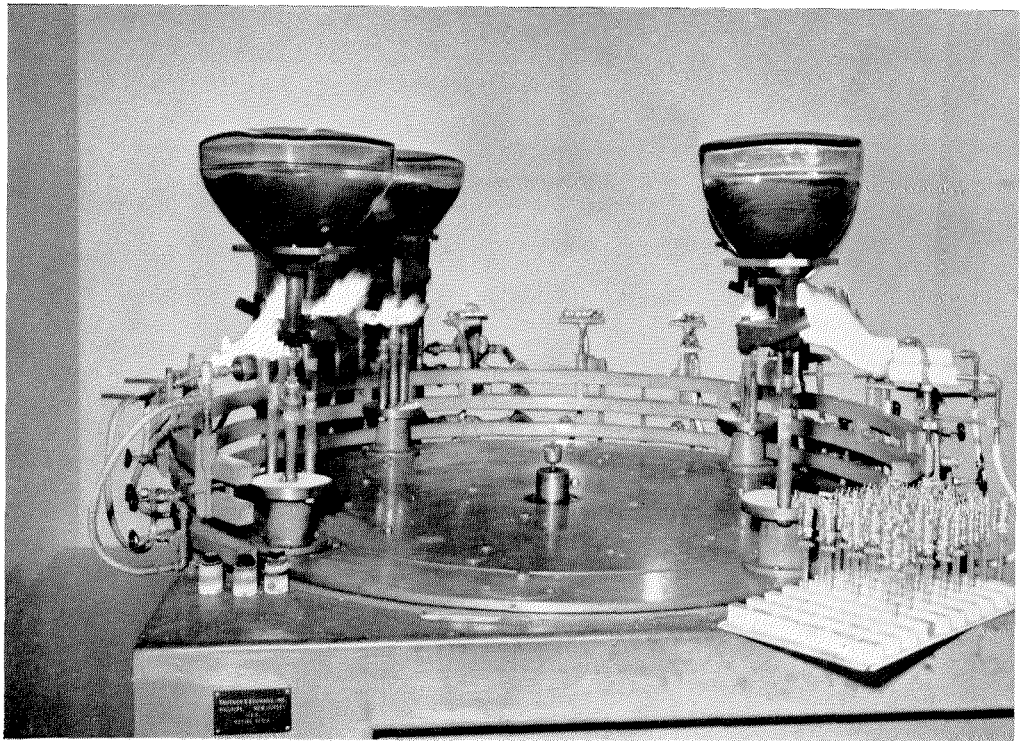

7. The exhausting oven is approximately 25 feet in diameter and has positions for 24 tubes. The tubes are heated by high-frequency induction apparatus and by gas flames to assure outgassing while being evacuated and are sealed off at the left.

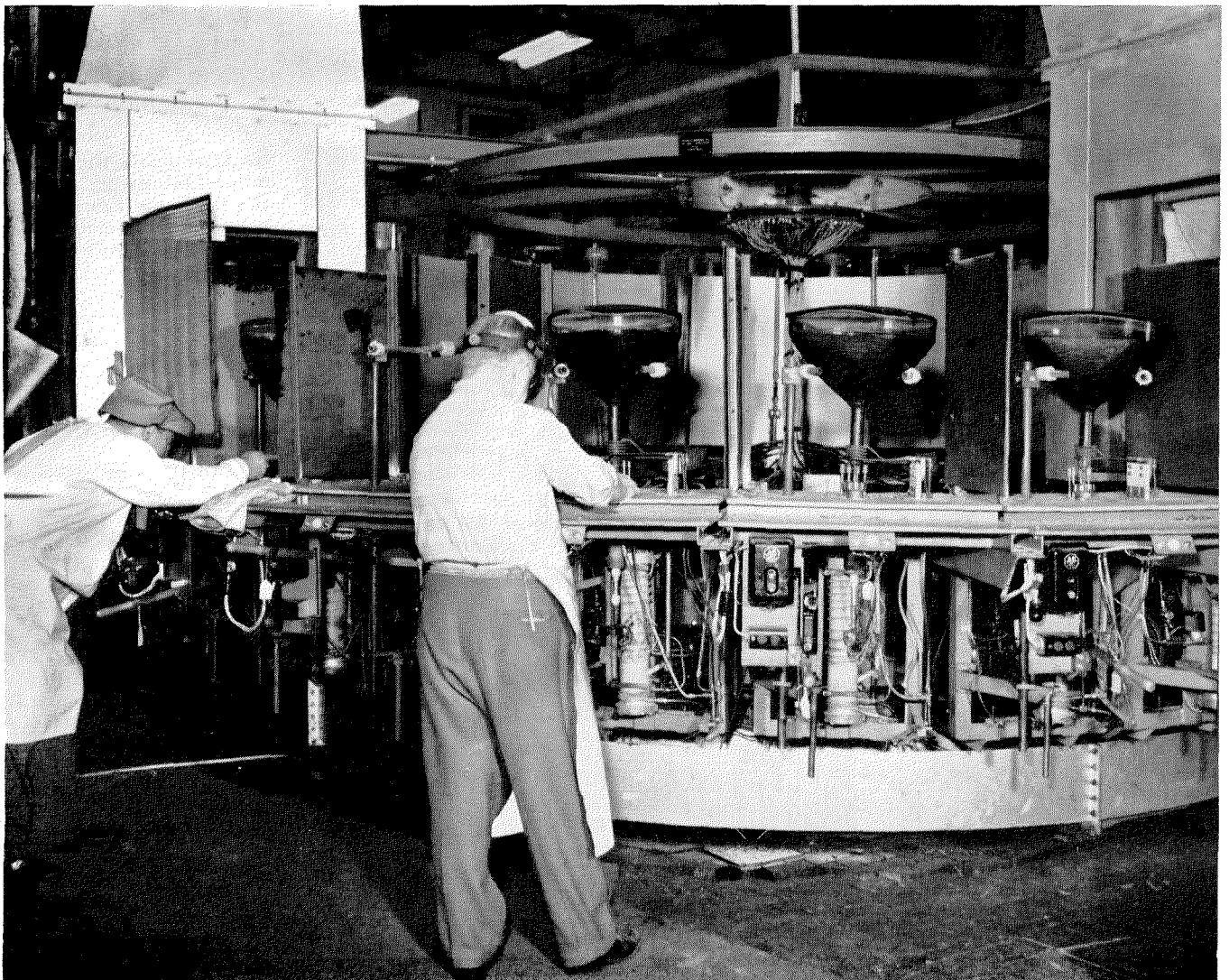

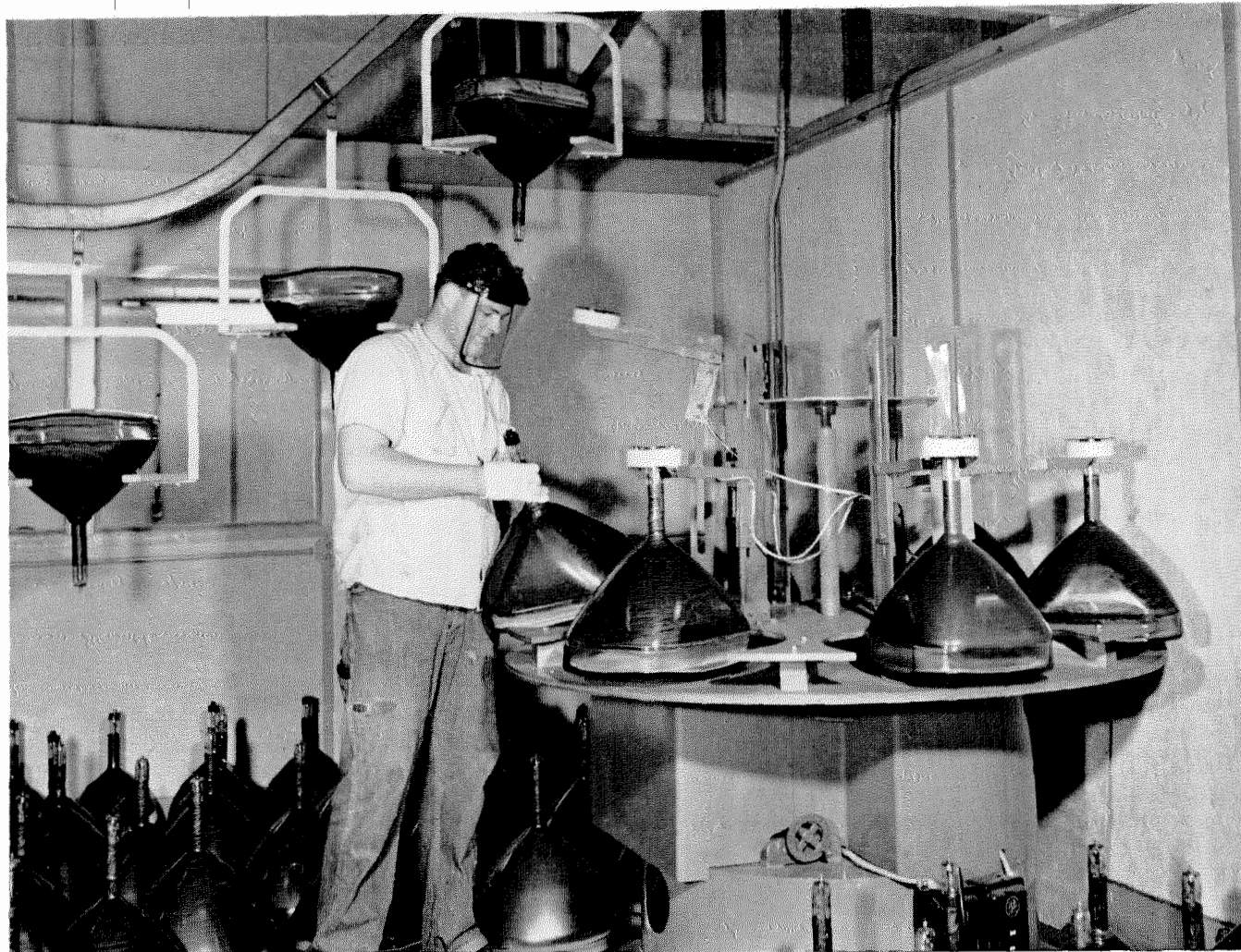

**8.** After firing the getter with induction-heating equipment, the bases are cemented to the tubes. Heating elements on the rotating table cure the cement.

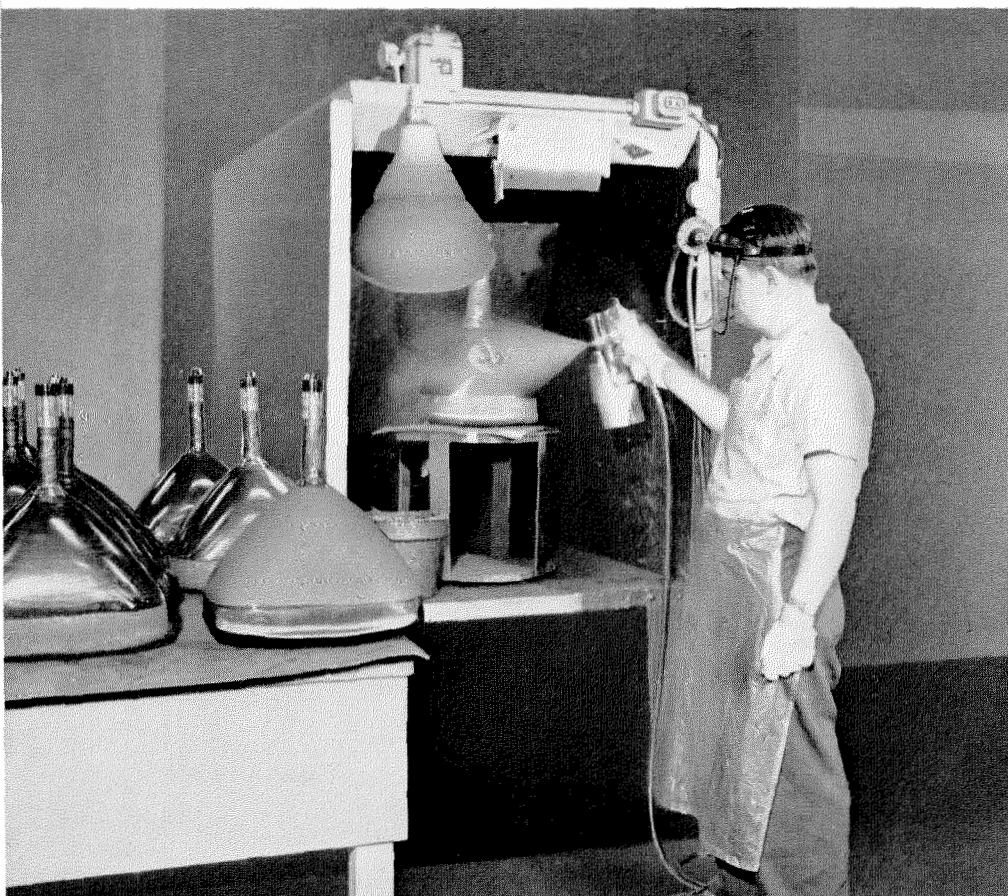

**9.** For some types of tubes, aquadag coating is sprayed on the outside of the tube for capacitance effect and shielding. Rubber masks prevent the aquadag from falling on certain areas of the tube, which is rotated on a small stand in the ventilated spray boot.

**10.** This is the testing position at the end of the assembly line. At the far right, tubes in a movable rack are undergoing an aging process. The operator at the test stand is using a photometer to measure the light output of the raster on the face of the tube in the cabinet. Provision is made for monitoring all tube-element currents and voltages under actual operating conditions. The tubes on the table at the left, which have been tested and approved, will be branded and in the background are being replaced in the original cartons for shipment to the customer. Wherever evacuated tubes are handled on the assembly line, face shields or goggles are worn to prevent injury to the operator in the event of an implosion.



# Rho-Theta System of Air Navigation

By P. C. SANDRETTO

*Federal Telecommunication Laboratories, Incorporated, Nutley, New Jersey*

**F**OLLOWING the earlier recommendations of its Special Communications Technical Division, the International Civil Aviation Organization adopted, under date of June 1949, the very-high-frequency omnidirectional radio range and the ultra-high-frequency distance-measuring equipment. The following is an excerpt from Annex 10 of the Standards and Recommended Practices.

In localities where conditions of traffic density and low visibility necessitate a short-distance radio aid to navigation for the efficient exercise of air-traffic control, the standard aid shall be the VOR (VHF omni-range) of the CW phase-comparison type conforming to the Standards contained in Paragraph 3.4 of Chapter III of this Annex.

Note 1—It is intended that UHF DME (Distance-Measuring Equipment) will become a basic component of the VOR at the earliest date practicable, to be added to all VOR which have been installed before that date. For guidance of Contracting States a set of Development Specifications for DME is set out in attachment B to this Annex.

The International Civil Aviation Organization is a subsidiary body of the United Nations and is responsible for recommending standard practices and equipment to promote international civil aviation for the world. The aids that it recommended in this case are for use in the enroute short-range zone; that is, where it is practicable to locate facilities at distances less than 200 miles apart.

Recommendation of the omnidirectional radio range and distance-measuring equipment was, in fact, adoption of the rho-theta system of air navigation. This is a new system in that it employs newly developed equipment operating at the very-high and ultra-high frequencies, but navigating by means of rho and theta, that is, distance and direction, is by no means new. In prehistoric times, man learned that he had a right and a left side and hence became acquainted with the factor of direction. Because he had to take a given number of steps to reach any desired place, man learned of the factor of distance; therefore, man has been navigating by means of rho and theta ever since he learned to change his locality.

Rho-theta is the classical system of navigation employed by the geographers. Distance from the poles is marked off by the parallels and direction around the poles is marked off by the meridians with the zero meridian passing through Greenwich, England. In the rho-theta system adopted by the International Civil Aviation Organization, the center of the system is the location of the antennas of the apparatus. Directional information is obtained by a special airborne receiver operated from the transmissions of the omnidirectional radio range, and distance is determined by an airborne interrogator-responder operating in conjunction with a ground transponder beacon. The material following will discuss these equipments and the methods by which they produce the two essential coordinates of this navigational system.

## **1. Determination of Direction (Theta)**

The need for an omnidirectional radio range to permit the determination of direction often has not been understood, and in many cases, omnidirectional radio ranges have been confused with nondirectional radio ranges (sometimes called radiophares, aerophares, or radio beacons). With an automatic or manual aircraft direction finder, it is possible to determine direction by taking a bearing on a nondirectional radio range, but the characteristics of the bearings so obtained are quite different from those that are produced by a navigational receiver obtaining its bearings from an omnidirectional radio range. The radiophare and the omnidirectional radio range are not at all similar, for while the radiophare has *no* directional characteristics whatsoever, the omnidirectional radio range has a characteristic in *each* direction that is totally different from its characteristic in any other direction. By identifying the characteristic being received at any moment, it is possible to determine the direction of the aircraft with respect to the radio station without reference to any other indicator.

The fundamental difference between the two systems is that in the case of the omnirange, as

with the 2- and 4-course ranges, tracks are laid down in space, whereas with the nondirectional beacon and airborne direction finder, no tracks are produced and only the bearing of the beacon relative to the aircraft heading is determined. The radiophare has no directional character-

landmark, from which observation a line of position on a chart may be determined only if a reference direction, such as true or magnetic north, is known.

To illustrate the difference between the information obtained with an aircraft direction

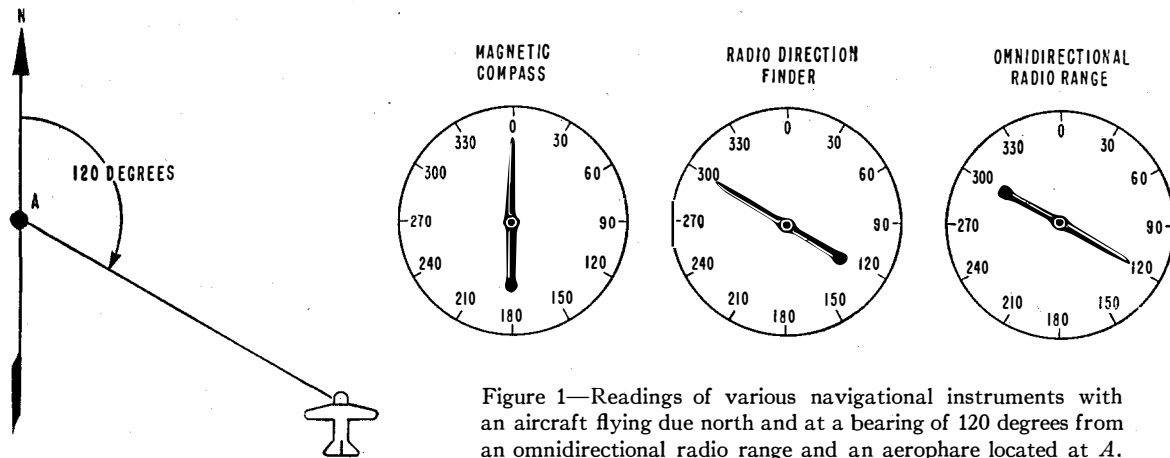

Figure 1—Readings of various navigational instruments with an aircraft flying due north and at a bearing of 120 degrees from an omnidirectional radio range and an aerophare located at A.

istics and it can be used for navigational purposes only if the aircraft is equipped with a device that is capable of determining the direction of arrival of the radio waves from it. While the omnirange receiver is a special device, it does not have in itself a means for determining direction of arrival of the radio waves. It merely identifies the characteristic of the premarked waves transmitted from the omnidirectional range. The omnirange system is similar to other forms of navigation such as consol and loran, which also lay down ground tracks that may be marked on charts. Direction finding, on the other hand, is similar to the visual observation of a fixed light or other

finder and a nondirectional radio range station and that obtained with a navigational receiver operating on an omnidirectional radio range, refer to Figure 1. This figure shows an airplane flying due north (magnetic). An omnidirectional radio range station and a nondirectional radio station are at point A. The aircraft is equipped with an omnidirectional receiver, a radio compass, and a magnetic compass. The magnetic compass reads 0 degrees (magnetic north), the automatic direction finder reads 300 degrees, and the omnidirectional radio range reads 120 degrees. Of course, the bearing reading from the omnirange can be converted to bearing toward

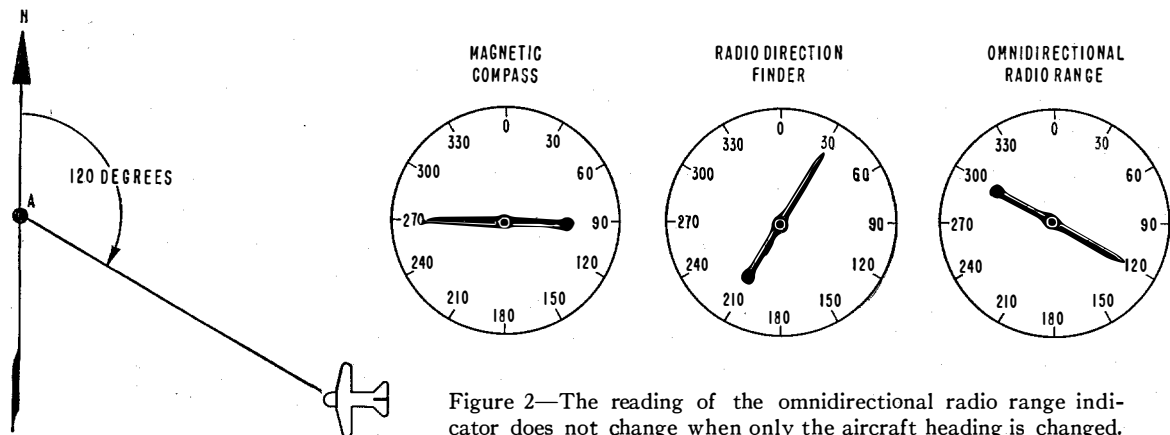

Figure 2—The reading of the omnidirectional radio range indicator does not change when only the aircraft heading is changed.

the range station by computing the reciprocal, which would mean that both the automatic direction finder and the omnirange bearings would be 300 degrees.

In Figure 2, the aircraft is now headed due west, but its position with respect to *A* has

the direction of the aircraft from the radio station does not directly affect the reading of the aircraft direction finder. To determine the direction, it is necessary to take into account the indication of the magnetic compass, and the magnetic deviation peculiar to the area in which

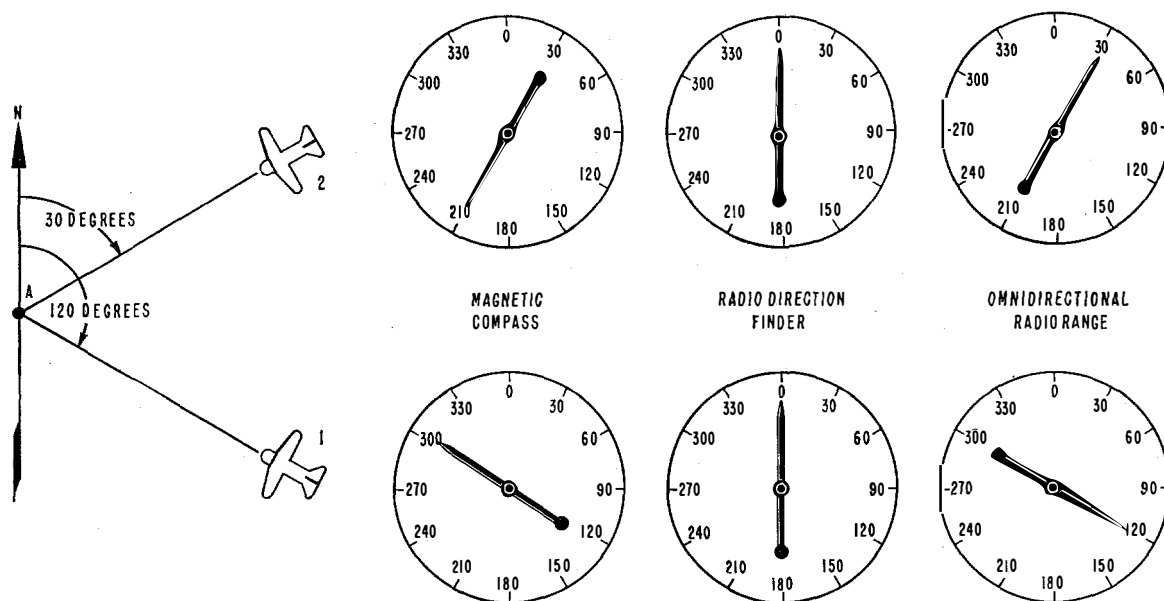

Figure 3—Differences in track location are indicated by the omnidirectional range but not the radio direction finder.

not changed. Now, however, the magnetic compass indicates 270 degrees, the automatic direction finder reads 30 degrees, but the omnidirectional radio range continues at 120 degrees (300 degrees). It can be seen that the automatic direction finder gives the bearing of the ground station relative to the heading of the aircraft and has no other meaning unless reference is made to the magnetic compass. By adding the magnetic bearing to the automatic-direction-finder reading, a bearing of 300 degrees can be obtained but, if for any reason the magnetic compass is in error, the directional information obtained will similarly be faulty.

Figure 3 shows two aircraft located in entirely different positions attempting to "home" to point *A*. This they do with the automatic direction finder by merely flying so that the reading on this device is 0 degrees. Note that while the aircraft are occupying entirely different positions, their automatic direction finders are giving the same reading, since they are both heading toward the same point. Thus, it can be seen that

the aircraft is flying. Because of the inherent inaccuracies of radio direction finders and magnetic compasses, and because the magnetic deviation is seldom known with great accuracy, the direction and position obtained with an automatic direction finder in an aircraft can never be determined with a high degree of accuracy. There is also the possibility of incorrect addition or subtraction of the magnetic variation.

In contrast to the behavior of the radio direction finder, note that the omnidirectional indications for the two aircraft in Figure 3, which are occupying different positions, are totally different, but that the readings in aircraft 1 of Figure 3, and those in Figures 1 and 2 each have the same value, regardless of headings. Thus, it can be seen that an omnidirectional system indicates the bearing of a given track, and if two aircraft fly with their omnirange equipments reading the same value, they will both be flying identically the same track, despite the fact that their headings (due to varying winds) may be very different.

## 2. Omnidirectional Radio Range

The use of a nondirectional station can be likened to the use of a simple light beacon. It would be easy to travel toward the light, but it would be impossible to tell one's geographic direction from the light. If a rotating white-light beacon is substituted for a simple light, if it is known that the beacon rotates at a constant speed (for example, one revolution per minute), and if a colored nondirectional light is flashed as the rotating beam passes through north, it would be possible to obtain the bearing merely by starting a stop watch the instant the colored light flashes and determining the time between the colored and the white flash of the rotating beacon. The bearing is determined by means of a time measurement, and this principle is somewhat similar to that used for the various omnidirectional radio ranges. The adopted device depends on the measurement of relative phase, which is a function of time.

Basically, the omnidirectional radio range system radiates two space patterns. One of these is circular (nondirectional) and contains the carrier frequency modulated by a low-frequency tone. The other pattern is a sinusoid rotated at 1800 revolutions per minute and contains only the carrier frequency.

The phase of the resulting tone from the rotating pattern relative to the phase from the nondirectional pattern varies with azimuth. The receiver in the aircraft is designed to measure accurately the difference between the phase of the tones in the rotating pattern and in the nondirectional pattern; therefore it accurately measures azimuth.

The reference phase signal is actually obtained by amplitude modulating the carrier with a subcarrier which is, itself, frequency

modulated by the low-frequency tone previously mentioned. By this means, the reference and the variable-phase signals can be conveniently separated in the receiver. Since the sideband pattern is nondirectional, and its phase is identical at all azimuths, the modulation can be used as a reference.

In the Federal omnidirectional antenna, which may be seen in Figure 4, a dipole fed with the unmodulated carrier rotates at 1800 revolutions per minute to produce in the receiver a 30-cycle amplitude-modulated wave. The antenna is mounted on a tower 15 feet in height with a 25-foot-diameter counterpoise. The transmitter is located in a house at the base of the tower and consists essentially of a 300-watt dual transmitter operating at one frequency in the band from 112 to 118 megacycles per second. This transmitter is amplitude modulated by a 10,000-cycle tone that is, in turn, frequency modulated  $\pm 500$  cycles at a rate of 30 cycles. The 10,000-cycle frequency-modulated tone is generated by a gear-toothed wheel mounted directly on the shaft that rotates the antenna. The modulated carrier and 10,000-cycle sidebands are impressed on a fixed horizontal antenna. The transmitter output also passes

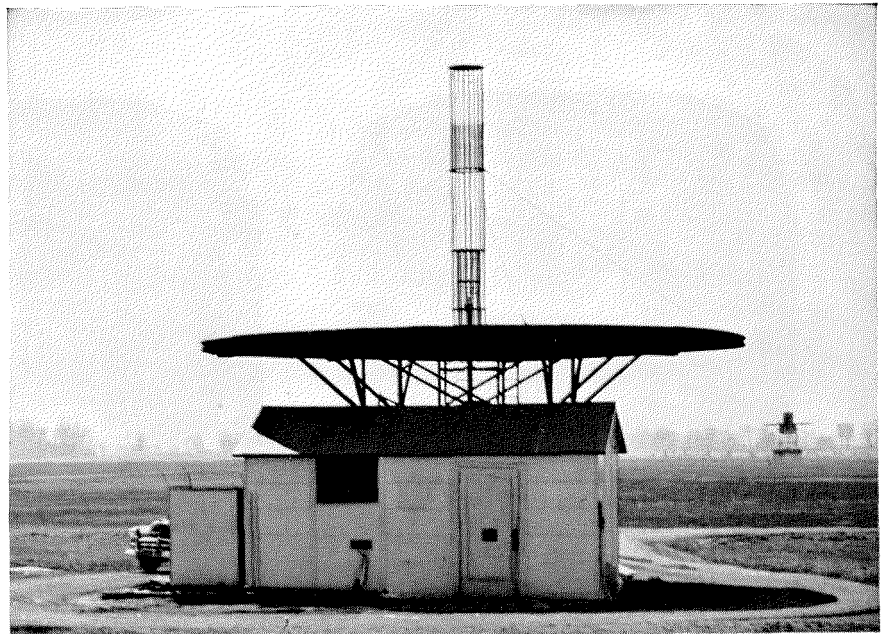

Figure 4—Federal omnidirectional radio range antenna operating at the Civil Aeronautics Administration experiment station at Indianapolis, Indiana.



through a clipper circuit, which strips it of all modulation, and the unmodulated carrier so obtained is connected to the rotating antenna. With the mechanism described, the phase relation of the radio-frequency carrier currents in the fixed and in the rotating antenna remain rigidly fixed.

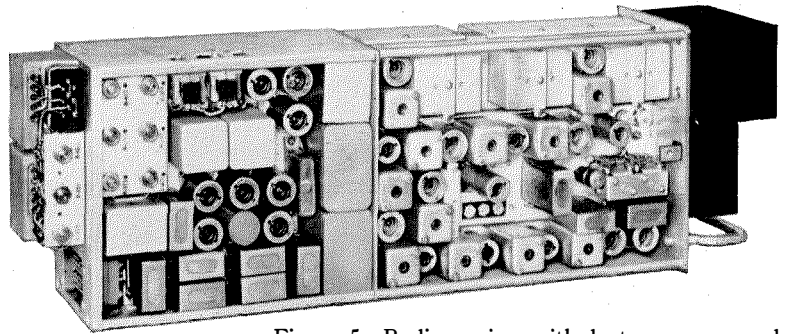

Figure 5—Radio receiver with dust cover removed.



Figure 6—Various indicators used with the receiver. At top are the flight-path-deviation indicator and omnibearing selector and below are the radio-magnetic indicator and omnibearing convertor.

A picture of a radio receiver used for reception of the very-high-frequency omnirange is shown in Figure 5. This receiver covers the band from 118 to 122 megacycles and furnishes 140 channels, each 100-kilocycles wide. It weighs approximately 25 pounds, not including power supply and auxiliary indicator circuits.

Figure 6 shows four indicators that may be operated from the omnirange receiver. The so-called omnibearing convertor gives data of the character discussed in regard to Figures 1, 2, and 3. The radio-magnetic indicator gives the readings from the omnirange, magnetic compass, and automatic radio direction finder all on one instrument. By means of the omnibearing selector, it is possible to select a radial to a station and then if the aircraft is flown so that the vertical needle of the flight path deviation indicator is on center, the aircraft will be following the selected radial. The flight-path-deviation indicator is also used with the rho-theta computer described later.

Before discussing the determination of distance, it may be well to discuss why it is necessary to have a second coordinate by which position may be determined continuously. Is it not sufficient to know that one is on the correct path to the desired destination and have knowledge of position only occasionally? While it is true that knowledge that an aircraft is on the correct path to its destination is sufficient in many cases, it is not sufficient information to allow the operation of aircraft in high-density traffic areas. The danger of collision in these areas makes it mandatory that the position of all aircraft be known with great precision at all times. The knowledge of position is also invaluable in maintaining a precise schedule to minimize delays in arriving at the terminal.

### 3. Determination of Distance

While navigators have been furnished for years with means for determining direction, until recent times they have never had methods for determining distance directly. Distance could previously be determined only indirectly by the measurement of direction from two radio stations. After plotting the bearings from two non-directional radio range stations, the intersections of the lines of position were used to determine the "fix," and distance to any desired point was measured on a chart from the fix. It is obvious

that such a procedure could not in general give a high degree of accuracy since a slight deviation in bearing results in a relatively great error in position, particularly when the distances from the radio stations on which the bearings were taken are large.

A second part of the rho-theta system consists of means for measuring *directly* the distance to each omnidirectional radio range station. These means are composed of separate ground and airborne equipment. By measuring distance to the same point as the bearing, high accuracy of position fixing results, and in addition, certain arbitrary paths may be produced as will be described later.

### 4. Distance-Measuring Equipment

The equipment used for distance measuring is of the pulse type. That is, a pulse is sent out from a transmitter in the aircraft and is received at a ground beacon that returns the pulse by retransmitting it on another frequency. The time required for the pulse to travel from the aircraft to the ground beacon and back to the airplane is measured and converted directly into distance. The reading of distance is given directly on a meter of the type shown in Figure 7. This meter is of the clock type with the pointer reading miles and tenths of miles while the inner dial

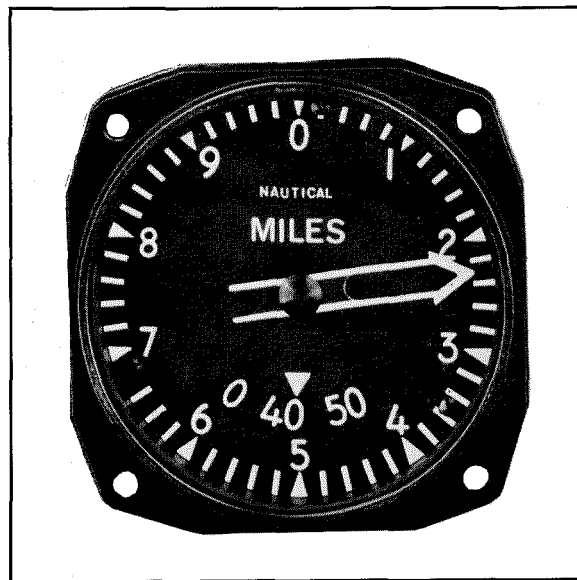

Figure 7—Indicator utilized with the Federal distance-measuring equipment. This is a standard three-inch aircraft instrument.

reads tens of miles. Thus, in Figure 7 the meter indicates 42.3 miles. This device is expected to be accurate to within approximately 0.2 mile. The range of the equipment will be about 100 nautical miles. The International Telecommunications Union, at its Atlantic City meeting, has set up the frequency band of from 960 to 1215 megacycles for distance measurement. Crystal-

controlled equipment<sup>1</sup> has been developed utilizing channels of 2.5-megacycle width and permitting the selection by push buttons of 100 separate operating channels. It is planned that only one control will be used for selecting both omnirange and distance-measuring stations.

<sup>1</sup> S. H. Dodington, "Crystal Control at 1000 Megacycles for Aerial Navigation," *Electrical Communication*, v. 26, pp. 272-278; December, 1949.

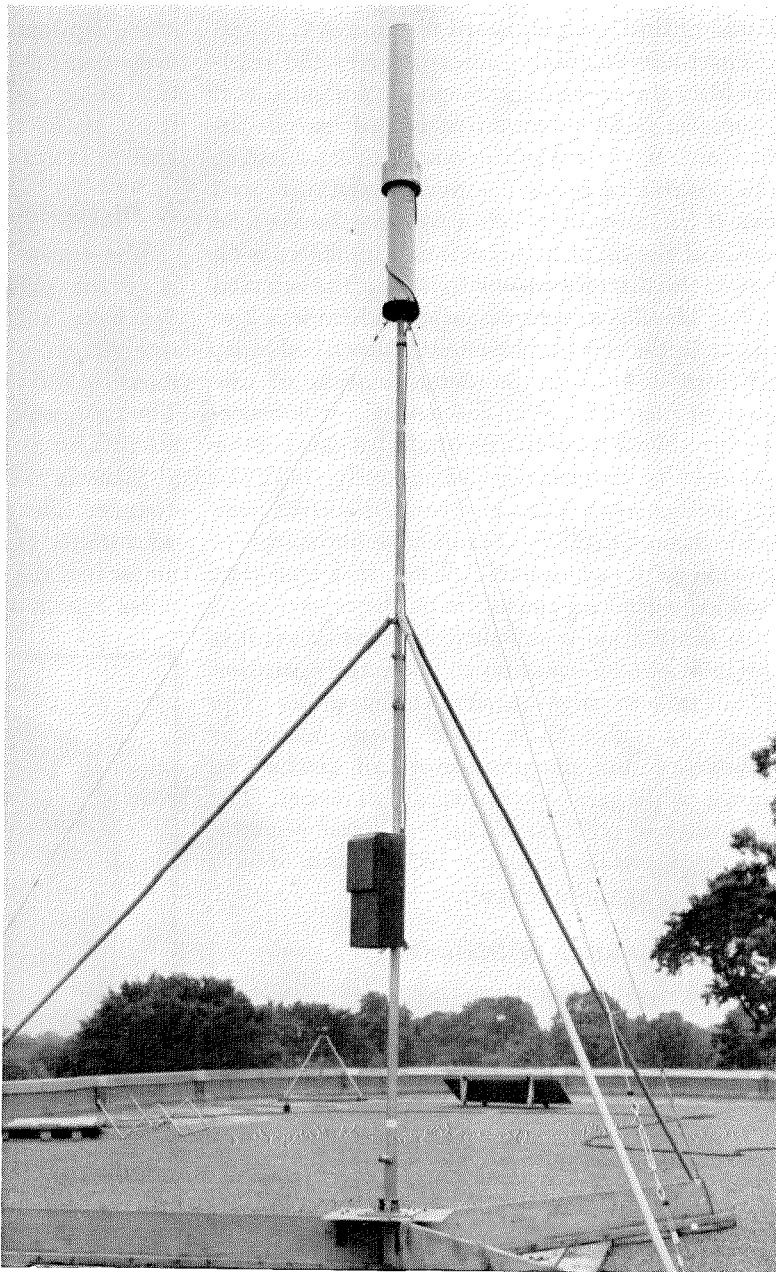
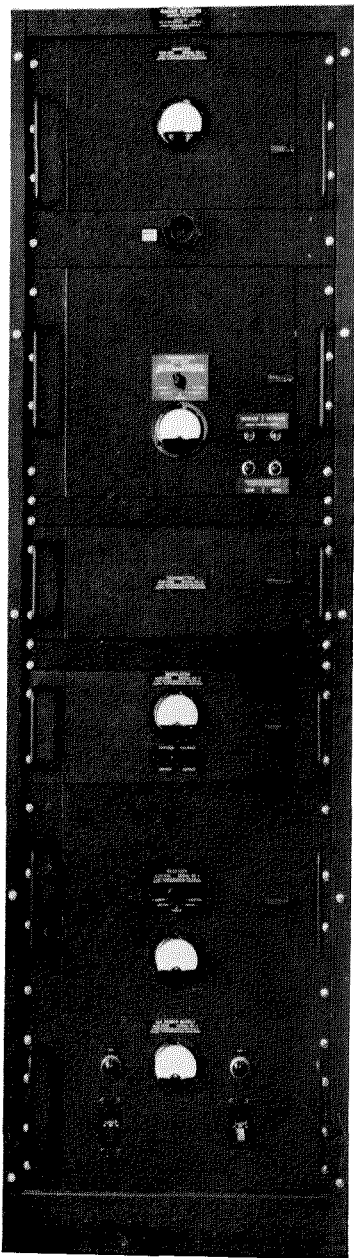

Figure 8—(Left) Federal distance-measuring ground-beacon transmitter. Figure 9—Distance-measuring-equipment ground antenna. Normally this antenna will mount in the upper structure of the antenna in Figure 4.

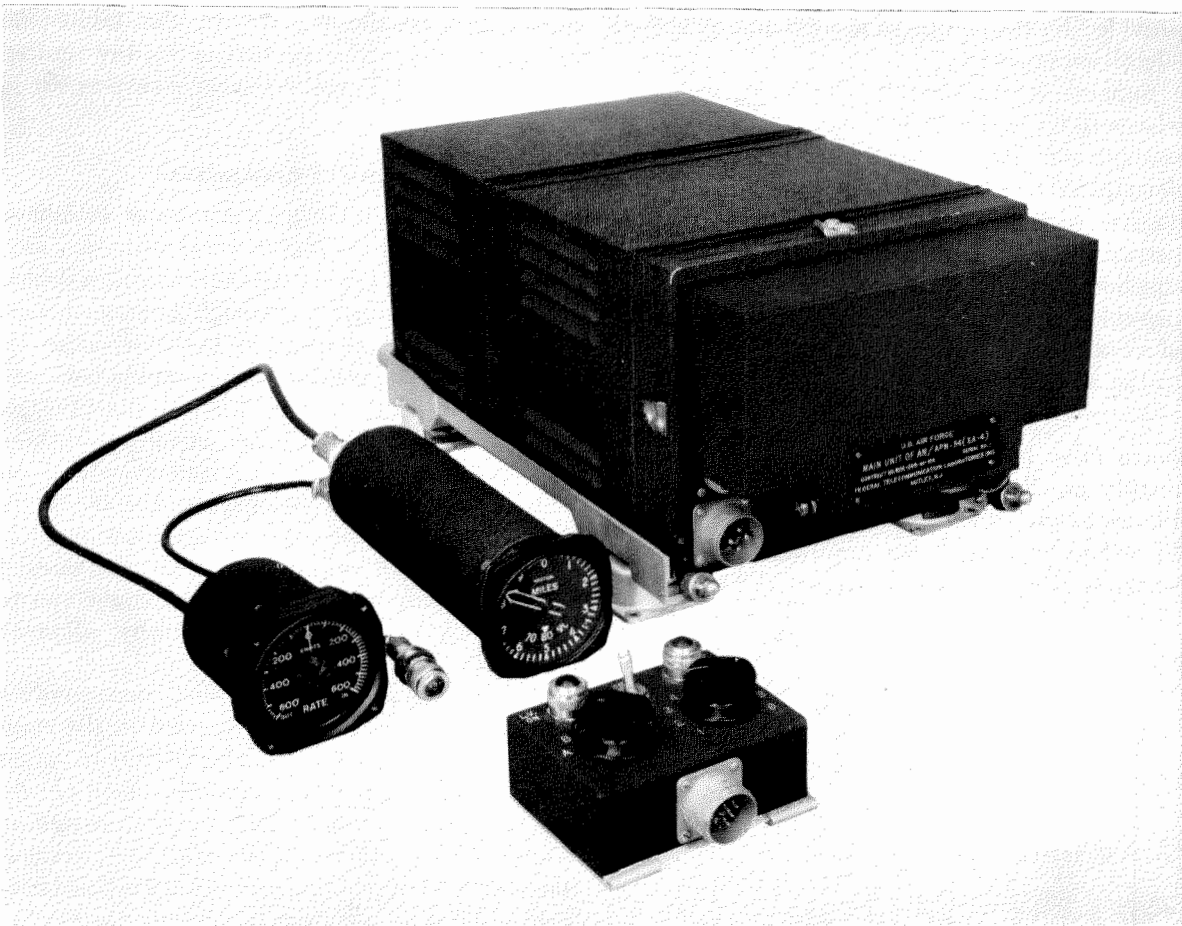

Figure 10—Airborne distance-measuring equipment.

Figure 8 shows the ground beacon of a distance-measuring system. Its antenna<sup>2</sup> is shown in Figure 9. Normally the antenna of Figure 9 will be mounted in the upper structure of the antenna of Figure 4. The beacon transmitters will be mounted in pairs (one plus spare) in the house shown in Figure 4. The airborne equipment, which weighs 45 pounds, is shown in Figure 10.

**5. Combined Rho and Theta**

Having means by which distance and bearing are read directly as shown in Figure 11, the pilot knows at all times exactly where he is. The selection of an omnirange frequency automatically selects the frequency of the distance-measuring beacon located at the same site and any desired radial to the radio station may be flown. Furthermore, certain additional facilities are

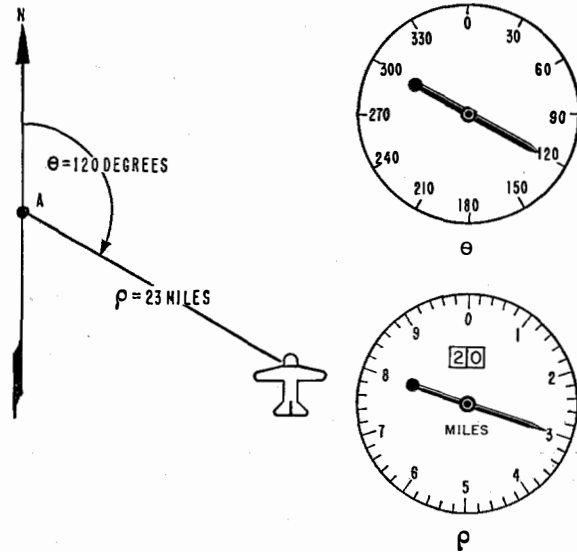

Figure 11—With instruments reading values of rho and theta directly, the pilot of an aircraft can appreciate his position at a glance.

<sup>2</sup> A. G. Kandoian, W. Sichak, and R. A. Felsenfeld, "High Gain With Discone Antennas," *Electrical Communication*, v. 25, pp. 139-147; June, 1948.

provided by the rho-theta system and extend its effectiveness greatly.

Suppose that an aircraft located as in Figure 12 wishes to fly to the airport shown. A line passing through the aircraft and the airport can be determined from a map as having a bearing of 30 degrees with respect to north. In addition, the perpendicular distance from the radio station to this line is 10 miles. By simple trigonometry, it is possible to determine that the polar coordinates of all points along the line connecting the aircraft to the airport are given by the relation

$$D/\rho = \sin(\theta - \phi).$$

Since  $D$  is 10 miles and  $\theta$  is 30 degrees, it is readily possible to compute the table shown in Figure 12 giving the values of rho corresponding to values of theta. By maintaining a course whereby the measured values of rho and theta

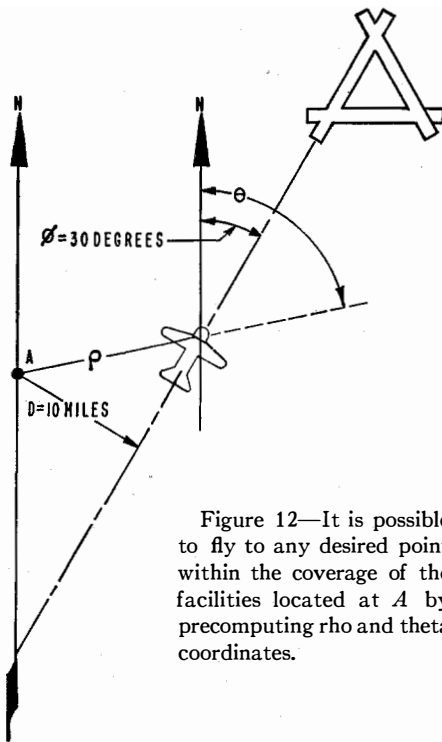

Figure 12—It is possible to fly to any desired point within the coverage of the facilities located at A by precomputing rho and theta coordinates.

$$D/\rho = \sin(\theta - \phi)$$

$\theta$ in Degrees	$\rho$ in Miles <sup>1</sup>	$\theta$ in Degrees	$\rho$ in Miles
180	20.0	110	10.1
170	18.5	100	10.7
160	13.1	90	11.5
150	11.5	80	13.1
140	10.7	70	18.5
130	10.1	60	20.0
120	10.0	50	29.3

correspond to those given in the table, the desired track to the airport, or to any desired point within the range of the radio station, could be flown.

### 6. Arbitrary-Course Computer

It is possible to design a computer to relieve the pilot of these course computations. Two voltage dividers having movable contacts driven by screws controlled through selsyn motors attached to the outputs of the omnirange receiver and distance-measuring equipment can be used to form the arms of a Wheatstone bridge. If one voltage divider gives an output voltage that is proportional to  $D/\rho$  and the other an output voltage proportional to  $\sin(\theta - \phi)$ , a balance read on the cross-pointer instrument of Figure 6 would indicate flight on the desired track. An automatic pilot can be connected to a cross-pointer instrument thereby allowing automatic flight.

Any values of the offset track corresponding to  $D$  and  $\phi$  can readily be inserted in the computer. If similar values of  $\phi$  but different values of  $D$  are selected by two aircraft, they will fly individual but parallel tracks and the problem of traffic control will be greatly simplified because the danger of overtaking another aircraft or being overtaken will have been minimized greatly.

### 7. Conclusion

From the foregoing discussion, it can be seen that there are many advantages to the rho-theta system. First, it is the natural system of navigation and the pilot can, at a glance, obtain an appreciation of his position with respect to a given location without the need for any calculation. He can accurately compute his ground speed and hence should be able to estimate times of arrival with an accuracy never previously attained in air operations. In addition, the rho-theta system possesses great flexibility. Any number of arbitrary tracks having definite coordinates can be set up and flown either manually or entirely automatically.

The Civil Aeronautics Administration has installed over 400 very-high-frequency omnidirectional radio ranges throughout the United States and these are being commissioned almost daily. Orders have been placed for the companion ground distance-measuring beacons.

# Medium-Power Traveling-Wave Tube Type 5929\*

By J. H. BRYANT

*Federal Telecommunication Laboratories, Incorporated, Nutley, New Jersey*

**T**HE TYPE 5929 traveling-wave tube operates in the band from 4400 to 5000 megacycles per second. It is rated at 10 watts of output power with 20 decibels of gain. It may be seen in Figure 1, and is a helix-type tube using waveguide input and output systems.

One requirement is that the tubes be interchangeable with a minimum of time and effort. The tube has, therefore, been equipped with alignment projections to insure that it is lined up with the magnetic field when placed in the amplifier assembly. A 14-pin medium-shell diheptal base is used with all but 6 pins removed. The base carries an indexing pin that permits the proper axial position to be selected so that no re-matching is necessary when changing tubes. An aquadag coating is applied to the outside of the bulb to give the required cold transmission loss of

30 decibels. An outline drawing of the tube is shown in Figure 2. The position of the indexing pin is fixed with respect to the helix input matching section. The collector is designed for use with a lightweight, finned cooler, which is removable from the tube.

The useful bandwidth is about 1000 megacycles and is determined by the helix-to-waveguide match. The power output and gain characteristics of a typical tube are shown in Figure 3. The average tube will give 23 to 26 decibels of gain at the 10-watt level and will produce 15 to 20 watts of output power with somewhat reduced gain. The highest output power obtained thus far is 33 watts with 17 decibels of gain. This highest power represents a beam conversion efficiency of 20 percent, where beam conversion efficiency is defined as the radio-frequency output power divided by the direct-current beam input power. This corresponds to large-signal operation, of

\* Presented at the Conference on Electron Devices at Ann Arbor, Michigan, on June 22, 1950.

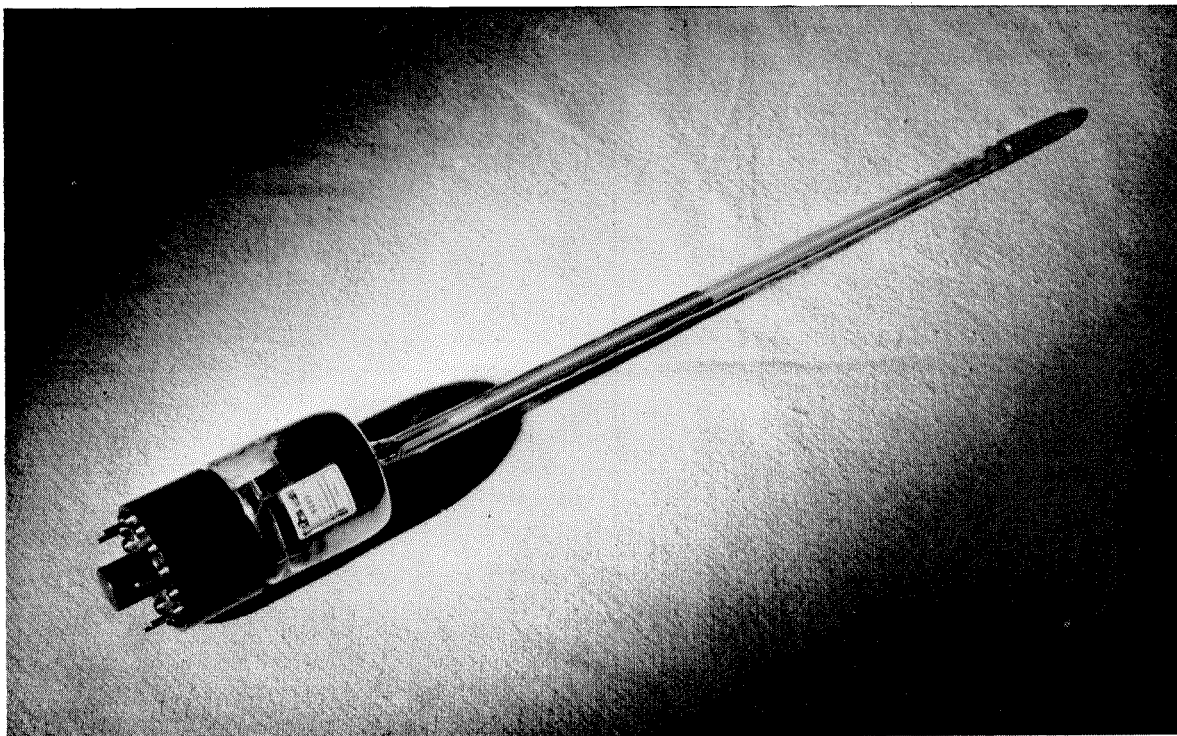

Figure 1—Type 5929 traveling-wave tube

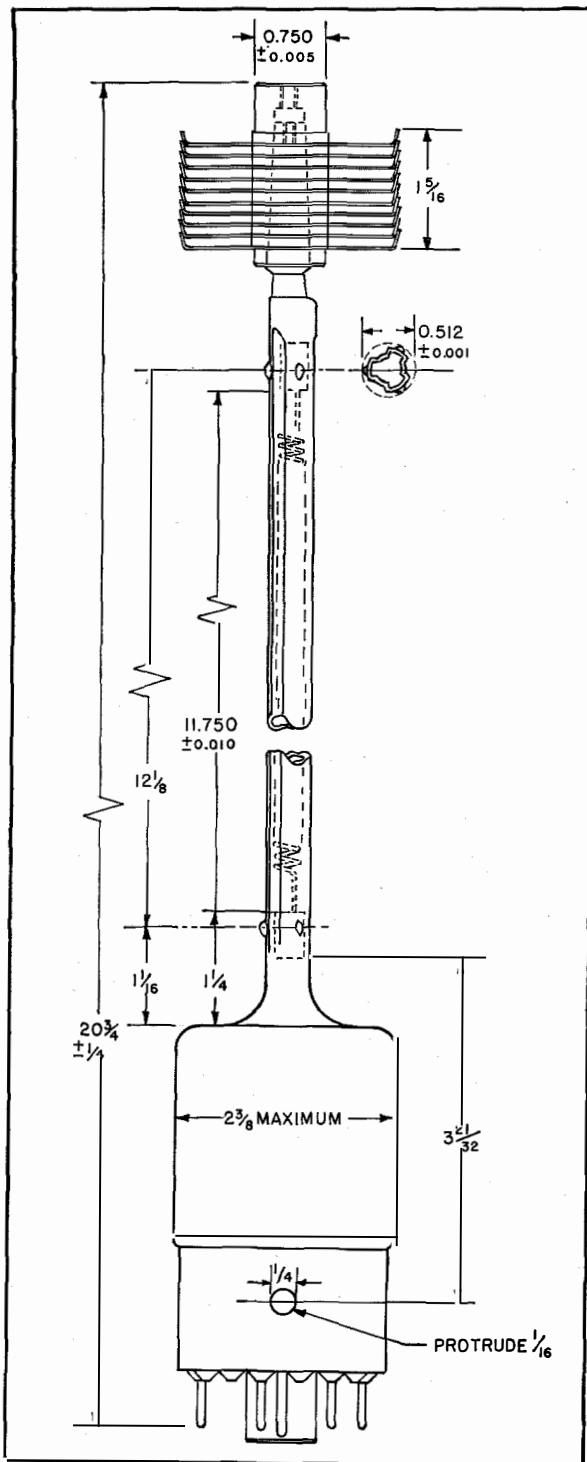

Figure 2—Dimensions of 5929 tube. The diheptal medium-shell 14-pin base carries only 6 pins. The cooler on the collector consists of 10 1 3/4-by-2 1/4-inch plates. All dimensions are in inches. The indexing pin on the base assures installation with the helix in proper position with respect to the matching section of the waveguide.

course, and no general large-signal theory for traveling-wave tubes is as yet available.

It is possible, however, to estimate a maximum efficiency.

$$\text{Beam Conversion Efficiency } \eta = \frac{\text{Radio-Frequency Output Power}}{\text{Direct-Current Beam Input Power}}$$

A number of workers have arrived at expressions for maximum beam conversion efficiency. The derivation given here is fairly simple and straightforward. In the process of amplification, direct-current kinetic energy in the electron beam is transferred to radio-frequency energy by a slowing down of the beam. It may be assumed that the maximum transfer of energy is determined by the range of velocity over which gain occurs. If  $v_a$  is the maximum velocity and  $v_b$  the minimum velocity for which gain is obtained, the maximum efficiency would be given by

$$\eta = \frac{v_a^2 - v_b^2}{v_a^2} \tag{1}$$

Let  $v_0$  be the small-signal synchronous velocity for maximum gain. As will be noted from Figure 4,  $v_a > v_0 > v_b$ . On a small-signal basis, the approximate range of velocity over which gain occurs is given by

$$\Delta v \cong \pm C v_0, \tag{2}$$

where  $C$  is the Pierce coupling coefficient. From (2),

$$\left. \begin{aligned} v_a &= v_0 + C v_0 \\ v_b &= v_0 - C v_0 \end{aligned} \right\} \tag{3}$$

Using (3) in (1) gives

$$\eta = \frac{4C}{(1+C)^2} \tag{4}$$

The theoretical value of  $C$  for this tube is 0.06, giving  $\eta = 21$  percent.

As a further experimental check, the following gain-voltage data were taken with constant beam current.

- $v_a = 3450$  volts, for unity gain,
- $v_0 = 3100$  volts, for maximum gain,
- $v_b = 2790$  volts, for unity gain.

Equation (1) may be expressed as

$$\eta = \frac{v_a - v_b}{v_a}$$

which with the above values gives  $\eta = 19$  percent.

Perhaps the greatest objection to the derivation given here lies in the expression for  $v_b$  in (3). This is because (2) is derived for small signals, which means a beam with very small modulation. This condition holds at the beginning of the helix,

be transmitted without excessively heating the helix is about 40 watts. To raise this value, a more-effective means of cooling the output portion of the helix would have to be found.

Although the 5929 tube is a power amplifier, it is of interest to note its operating characteristics at small-signal levels. The gain at small-signal levels is 30 decibels and the noise figure is 29 to 30 decibels.

Traveling-wave tubes are especially suited for output stages in transmitting equipment because their performance is insensitive to output match to the load or antenna. This is in contrast with klystrons or magnetrons in which tuned circuits or cavities are used, resulting in fre-

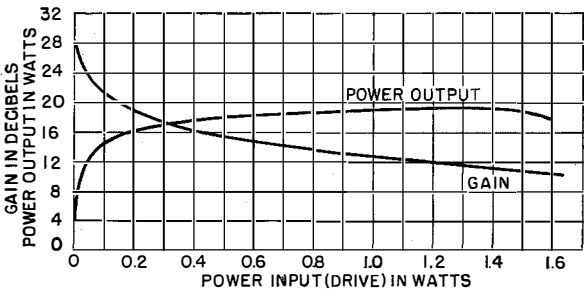

Figure 3—Power output and gain characteristics of a typical 5929 traveling-wave tube. Operation was at 4700 megacycles and power output at each point was maximized with helix voltage. The cold insertion loss was 27 decibels.

and  $v_a$  in (3) is consistent with (2). At the output of the helix, however, the beam is strongly bunched for large-signal operation so that  $v_b$  in (3) is not necessarily consistent with (2). The effect may be small and in the absence of a good large-signal theory of traveling-wave tubes, (4) may be used to estimate the maximum obtainable efficiency when the design information is given.

An estimate may be made as to the best efficiency obtainable with traveling-wave tubes. With a coupling coefficient of 0.1, which is not difficult to obtain, (4) gives 33-percent efficiency. Traveling-wave tubes have been operated at nearly this efficiency, and it seems that tubes can be designed to operate at 30- to 35-percent efficiency.

The limit of maximum stable continuous-wave power obtainable with a helix-type traveling-wave tube is set by the radio-frequency power transmission capabilities of the helix. In a well-designed tube, the helix heating due to intercepted beam current is very low. Consider, on the other hand, the dissipation of radio-frequency power in the helix. Because of the amplification process, the maximum radio-frequency power appears at the last few turns. With the present helix, which is copper-plated, the maximum continuous-wave radio-frequency power that can

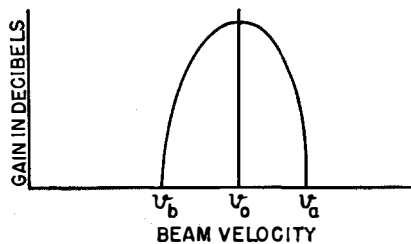

Figure 4—An illustration of the range of velocity over which gain is obtained.

quency pulling and reduced output power with slight changes in load impedance. A traveling-wave tube output stage very effectively isolates the antenna from preceding stages.

The 5929 traveling-wave tube has undergone extensive system and life tests, giving satisfactory performance. A preproduction pilot run has shown that the operating characteristics are entirely reproducible.

**Acknowledgment**

This work was carried out under the sponsorship of the Camp Evans Signal Laboratories of the United States Army Signal Corps. Acknowledgment is made to Messrs. G. C. Dewey, now with the Department of Defense, Washington, D. C.; T. J. Marchese, C. P. Majkrzak, and others who contributed in large measure to the development and mechanical design of the tube described here. The testing of experimental tubes was carried out by Mr. S. Stein.



# Automatic Switching of Telegraph Messages

By E. J. AGNEW

*Western Union Telegraph Company, New York, New York*

**R**EPERFORATOR switching, integrated with carrier and radio circuits, as developed by the Western Union Telegraph Company, has resulted in a completely new nationwide telegraph system in the United States. The transmission paths have been arranged to eliminate manual retransmission of telegrams. Messages are transmitted at originating points and pass through the telegraph network to their destinations without being retyped at any intermediate place. This has increased greatly the efficiency of telegraph service.

• • •

## 1. Block State Routing

The entire country is divided into 15 geographical areas as shown in Figure 1. Each area includes one or more entire states, all localities of which will have direct connection to an area switching center. Each area center will have direct connections to the other 14 area centers. Thus no telegram will pass through more than two area centers enroute from origin to destination. By careful analysis of the interchange of communications between cities and areas, the system has been arranged to provide direct point-to-point service.

The rearrangement of the nationwide distribution system was made possible by a tremendous expansion of plant facilities. Ground-return trunk circuits are being replaced by carrier channels derived from metallic wires and radio transmissions which, due to increased freedom from earth currents, inductive disturbances, and weather conditions, insure a stability of operation and continuity of service that is not possible over ground-return circuits.

## 2. Carrier Circuits

Approximately 5500 individual telegraph circuits are in service and include 1,600,000 circuit miles of carrier telegraph channels. The network

employs a multiplicity of voice-frequency bands, each of which is subdivided to provide up to 20 telegraph channels. Frequency modulation is employed on all channels to obtain stable operation unaffected by normal variations in signal level.

New central or relay offices have been installed in each of the area centers, which form the nucleus of the new distribution system. They have been equipped with switching systems of the most modern type and the time required for a telegram to be transmitted through these offices is greatly reduced.

## 3. Mechanized Operation

Figure 2 contrasts pictorially the old manual method of routing and handling a message with the reperforator switching or automatic method currently in use.

The top half of the figure indicates the former route of a message originating at Cheyenne, Wyoming, and destined for Annapolis, Maryland, with manual relaying. The message would be received, routed, and resent three times in addition to the original sending at Cheyenne and the final reception at Annapolis. All three relay offices would have a printed copy of the message on a telegraph blank, which would be filed as a relay copy.

Under the reperforator switching method shown at the bottom of the figure, the only sending operation required is at the originating office in Cheyenne. The message is passed through Kansas City, where the operation is entirely automatic, and Philadelphia, where a switching operator reads the destination and operates a push button labeled "Annapolis." All records of the message at Kansas City and Philadelphia are on continuous rolls of tape.

Before describing this modern telegraph switching system, the fundamental theory of teleprinter operation will be given, since all transmissions between an area center and its branch and tributary offices is on a start-stop teleprinter basis.



Figure 1—The 15 areas into which the United States have been divided for the routing of telegrams. All places in each area are connected directly to the area centers in the cities shown.

#### 4. Start-Stop Telegraph System

Figure 3 shows the circuit arrangement of a start-stop telegraph system. The sending distributor may be seen at the left and the receiving distributor is at the right. The brush arms are driven at a constant speed by synchronous, or accurately governed, motors. The receiving arm rotates slightly faster than the sending arm, so that the start signal at the sending distributor

mechanism of the receiver for selecting the perforating and printing characters.

The idle condition of the circuit is shown; both brush arms are in their rest positions. Line current maintains the receiving stop magnet energized and the brush arm at rest.

If the sending key is pressed momentarily, the sending stop magnet is energized, releasing the brush arm. The line current through the receiving stop magnet is interrupted when the sending

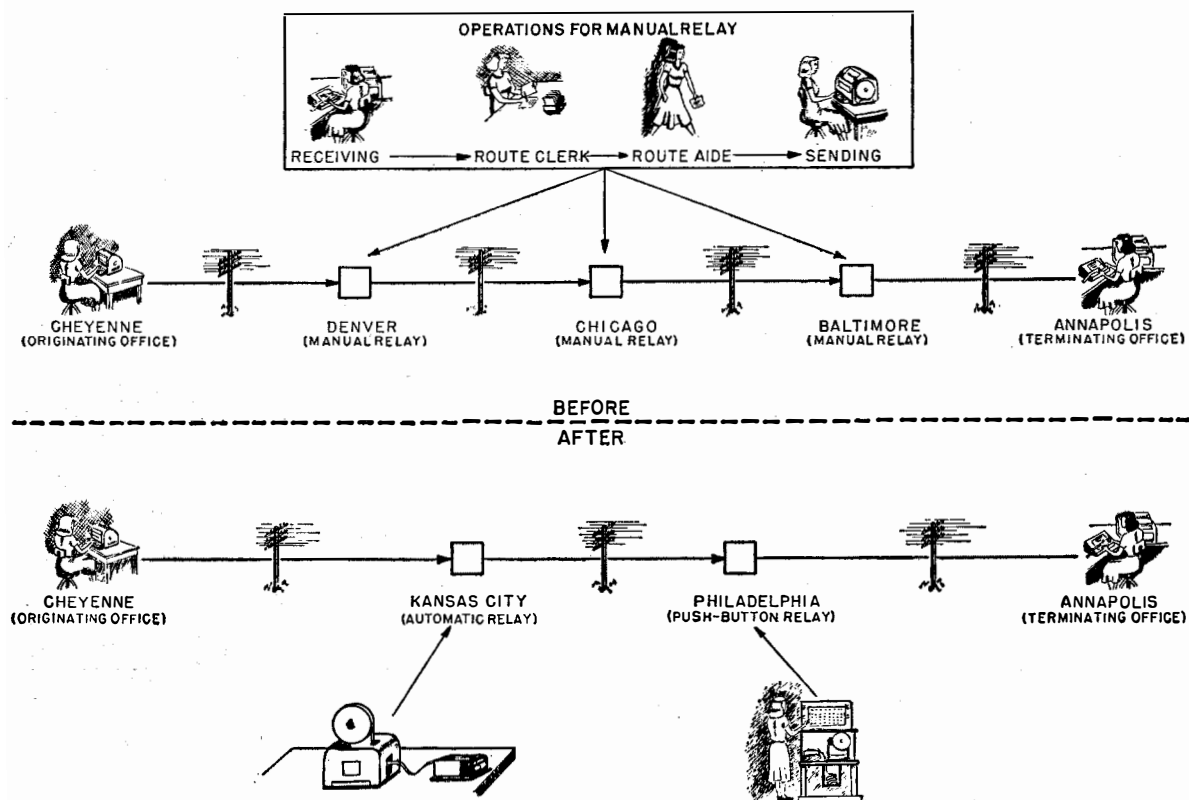

Figure 2—Typical routing of a message going from Cheyenne, Wyoming, to Annapolis, Maryland. In the older system shown above the dashed line, manual operation predominated. The mechanization program has reduced both the number of manual handlings per relay and the number of relays.

will always cause the brushes to leave the rest segment of the receiving distributor at the same time, thereby maintaining the proper phase relation between the two stations.

At the left of the diagram, 5 contacts are shown to represent the contact pins of a transmitter. The contacts would be open or closed depending on the code combinations corresponding to the key depressed on the transmitter. Similarly, the 5 coils at the right correspond to the activating

brush leaves the *R* segment of the distributor, releasing the receiving brush arm. The contacts on the receiving distributor are so spaced that the brushes rotate simultaneously over identically numbered segments at the two stations, and the receiving coils corresponding to the closed sending contacts are energized.

This system is commonly called a start-stop 7-unit system, 5 units being used for information, and the other 2 for synchronizing purposes. The

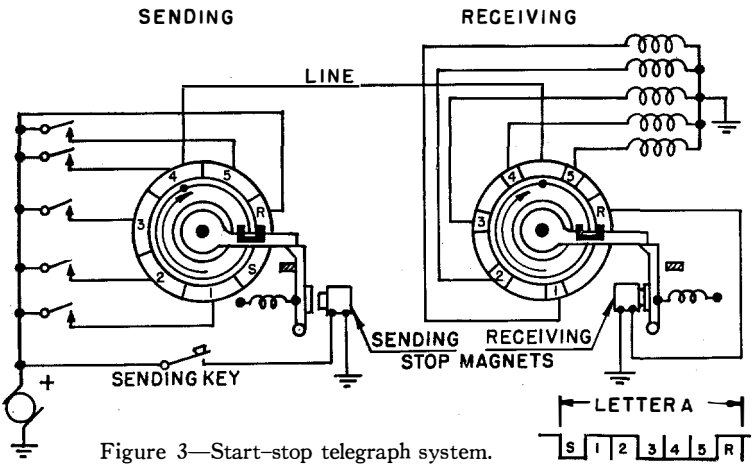

Figure 3—Start-stop telegraph system.

other areas, several cities such as New Haven, Hartford, White River Junction, and Portland are connected to the Boston office by carrier circuits and are called bundling points. The carrier channels at these bundling points are connected to tributary offices by extended-leg teleprinter circuits. Thus, the tributary offices have direct connection with the Boston switching center.

The principal equipment and circuit arrangements employed in a modern reperforator

first pulse of each character is a spacing pulse and is followed by 5 information pulses. Each of the 5 message pulses may be either marking or spacing. The 7th pulse is the marking stop or rest pulse, which is maintained until the start of the next character.

A line signal for the letter *A* is shown at the bottom of the diagram; pulses 1 and 2 are marking and positions 3, 4, and 5 are spacing.

switching center are shown in Figure 6. The receiving channels of typical circuits are shown terminated in receiving equipment on the right-hand side of the diagram. The associated sending channels are shown on the left-hand side. Be-

4.1 TAPE

A tape perforated for the 5-unit code is shown in Figure 4. There are two characters for each perforation pattern, the desired character being determined by operation of the "letters" or "figures" keys.

A printer-perforator tape of the chadless type is shown in Figure 5. In this tape, the perforations are not complete and the flaps of paper are still attached. Its principal advantage is the ability to print on the tape directly over the perforations. Of course, the fact that there are no chads to dispose of, is a convenience.

5. Switching Center

In the New England area, which is served by the Boston switching center and is typical of the

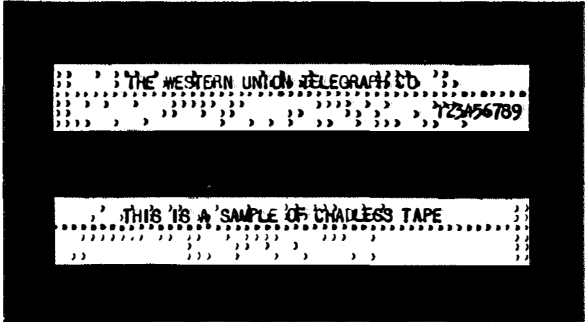

Figure 5—Chadless tape on which the message may also be printed. The printed characters are offset from the corresponding perforations.

tween them are the intraoffice apparatus and switching circuits.

Approximately half of the reperforator switching system is operated on an automatic basis, while the remainder employs manual push-button switching. Telegrams that originate within an area and are transmitted into the switching system at the area center from tributary and city branch offices are automatically switched into interarea trunks by means of selection characters prefixed to each message

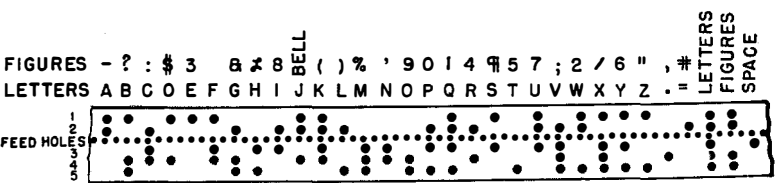

Figure 4—Sample of 5-unit-code perforated tape.

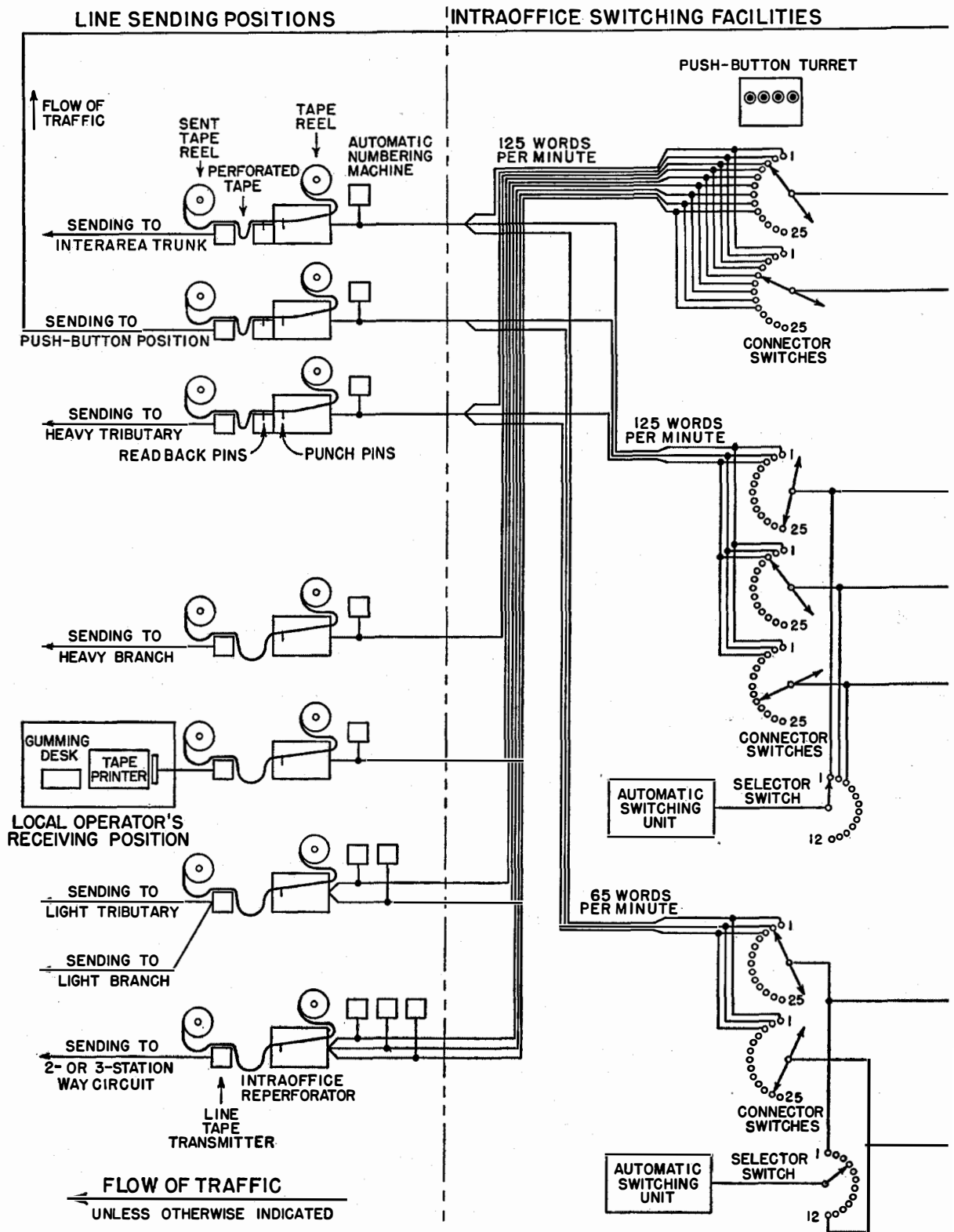
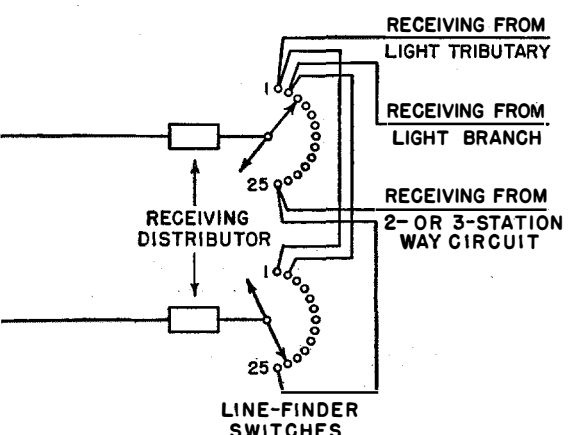
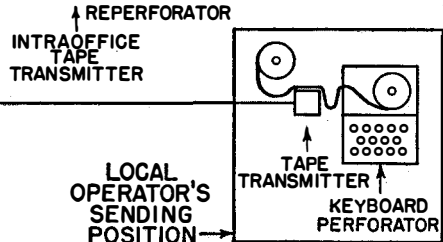
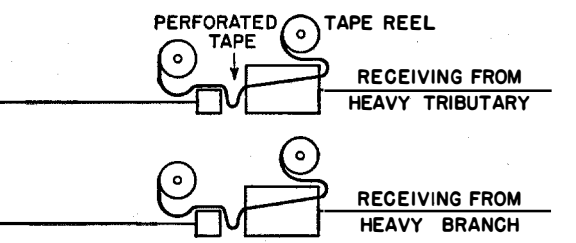
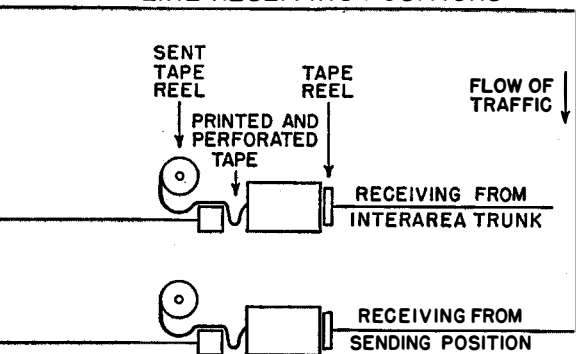

Figure 6—Schematic arrangement of reperfocator switching center.

LINE RECEIVING POSITIONS



and pass automatically to the distant centers. In the opposite direction, messages received over interarea trunks are switched by the mere pushing of a button to tributaries and city branches.

5.1 PUSH-BUTTON SWITCHING

A line receiving position consists principally of a printer-perforator, an intraoffice tape transmitter, and a turret in which a push button is provided for each sending destination. One switching turret is associated with several receiving positions.

Heavily loaded trunk circuits from other large cities and from area centers are terminated in these line receiving positions. Messages received over these circuits at 65 words per minute are recorded in both printed and perforated form on a single tape.

The tape feeds from the printer-perforator across the top surface of a tape transmitter in a position where the address of the message can be read easily by the switching clerk.

The fundamental requirements of reperforator switching in the area center can best be explained by first describing in a general way the operation of the intraoffice facilities in switching a message from the line receiving position to a line sending position.

Each message received at a line receiving position has a prefix consisting of the call letters of the originating office and the sequence number of the message.

The switching clerk checks the sequence number to guard against the possible loss of a message and reads the address as recorded on the printer-perforator tape. She marks off the sequence number on a tally sheet and records the call letters of the destination to which the message is to be switched.

The switching clerk depresses the destination button on the switching turret, initiating a request for a connection to the selected line sending position. If the sending position is busy, the transmitter waits its turn. When it becomes idle, the transmitter automatically seizes the intraoffice circuit and immediately "busies" it to any other waiting transmitter.

As the intraoffice circuit to the line sending position is seized, an automatic sequence number, the call letters of the area center, and the channel



Figure 7—Push-button switching position.

designation of the outgoing circuit are sent into the intraoffice reperforator ahead of the message. The intraoffice transmitter then sends the message into the reperforator at high speed, usually 125 words per minute. This is nearly twice as fast as the line speed of 65 words per minute at which the messages are received at the switching positions. This increased intraoffice speed is made

possible by the use of a 5-wire intraoffice circuit over which the 5 impulses for each character are transmitted simultaneously. This differential in speed allows for time consumed by the operating functions and transmitter waiting time.

When the two consecutive periods at the end of the message are transmitted over the intraoffice circuit, they are detected by period-reading

relays and the transmitter is stopped and disconnected immediately from the intraoffice circuit.

At the sending position, the message is recorded by the reperforator on a tape, which feeds into the associated line transmitter and sends the message to the branch or tributary office. Each sending position may receive messages from any receiving position and as the cross-office circuits operate at high speed each transmission circuit is maintained at full capacity as long as there are any messages stored in the tape.

A view of a push-button switching position is shown in Figure 7. Three incoming trunk circuits are terminated in printer-perforators. Two are shown on the right and one is below the push-button turret.

During peak loads, one operating position, consisting of the three incoming trunk circuits, may require the full time of one switching operator. At other times, one switching operator can take care of several positions.

Route charts are mounted above the push-button turrets to indicate the correct outgoing circuit, when the operator is not familiar with the destination shown on the incoming message.

## 5.2 CONCENTRATOR FACILITIES

The receiving sides of the heavy tributary circuits are terminated directly in individual reperforators at line receiving positions and these offices may send messages continuously.

One receiving position could be provided for each lightly loaded tributary office, but a more economical arrangement is achieved by terminating these receiving channels in concentrator facilities termed line finders, which connect a calling line to a receiving distributor for the duration of one message. Line finders permit a large number of receiving channels to be served by a smaller number of receiving distributors.

When the operator at the out-office has prepared at least one message in perforated tape form, she initiates a request for connection by pressing a push button. In response to the call, the calling line is connected at the reperforator office to an idle receiving distributor and an automatic switching unit. An automatic signal from the receiving distributor causes the out-office transmitter to send the selection characters and permit the automatic switching unit to con-

nect the receiving distributor to the desired line sending position. The message is then transmitted from the out-office transmitter directly to the intraoffice reperforator at the line sending position. Thus the intermediate reperforation, which occurs at the line receiving positions of heavily loaded circuits, is eliminated on lightly loaded circuits.

Figure 8 shows some of the apparatus that automatically switches the messages. It is housed in an air-conditioned dust-proof room for the protection of the necessarily large number of electrical contacts. At the bottom of the racks is a row of office-call selectors (cover removed on one at right), which set up the actual connections after the selection characters have been determined.

The intraoffice reperforators at line sending positions are operated on a 5-wire basis, one wire for each unit of the 5-unit code. All 5 units for each character are transmitted simultaneously.

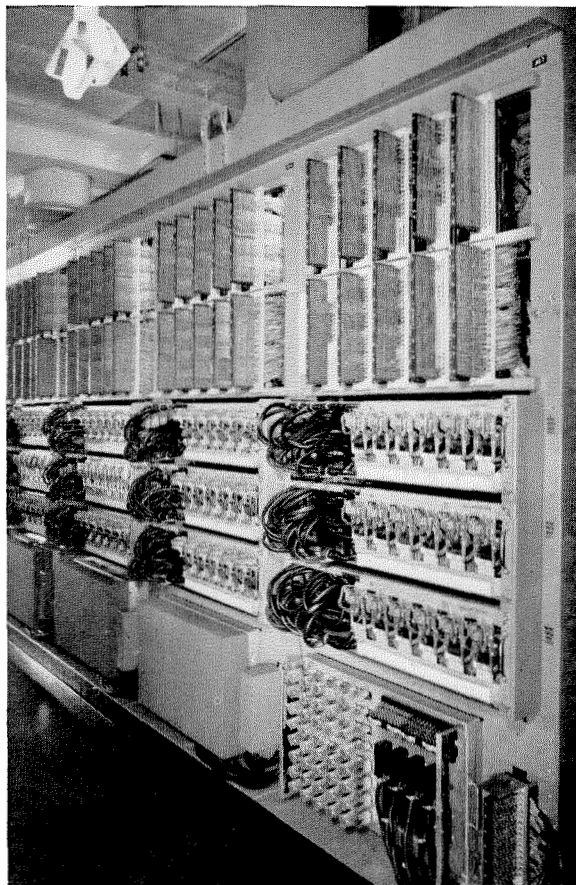

Figure 8—Automatic switching equipment.



Transmission from an out-office to the area center utilizes the start-stop code in which 7 code units for each character are transmitted consecutively. Therefore, in making a connection between an intraoffice re-perforator and the receiving channel of a lightly loaded out-office, it is necessary to inter-

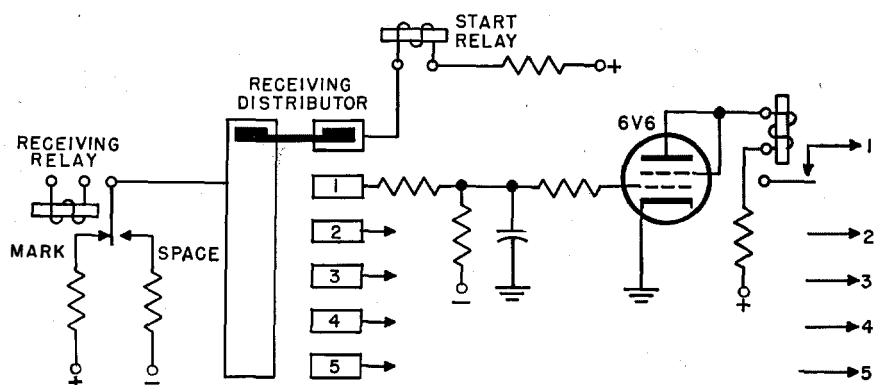

Figure 9—Circuit for converting from the 7- to the 5-unit code.

pose a start-stop receiving distributor to convert from the 7- to the 5-unit code.

Figure 9 shows schematically the method of converting from the 7-unit to the 5-unit code. The receiving leg, or line, is connected to the receiving relay, which idle line current holds energized. Through its marking contacts, a circuit is closed to the start magnet of the receiving distributor, which is shown in its idle position with its brushes on the rest segment. The control grid of the 6V6 tube is at negative potential and the relay in the plate circuit is not energized. Similar tube circuits are interposed between the other numbered segments and the output arrows.

As a start, or spacing, signal is transmitted

Figure 10—A group of receiving distributors for converting from the 7- to the 5-unit code. Four face-plate distributors are mounted on each rack.

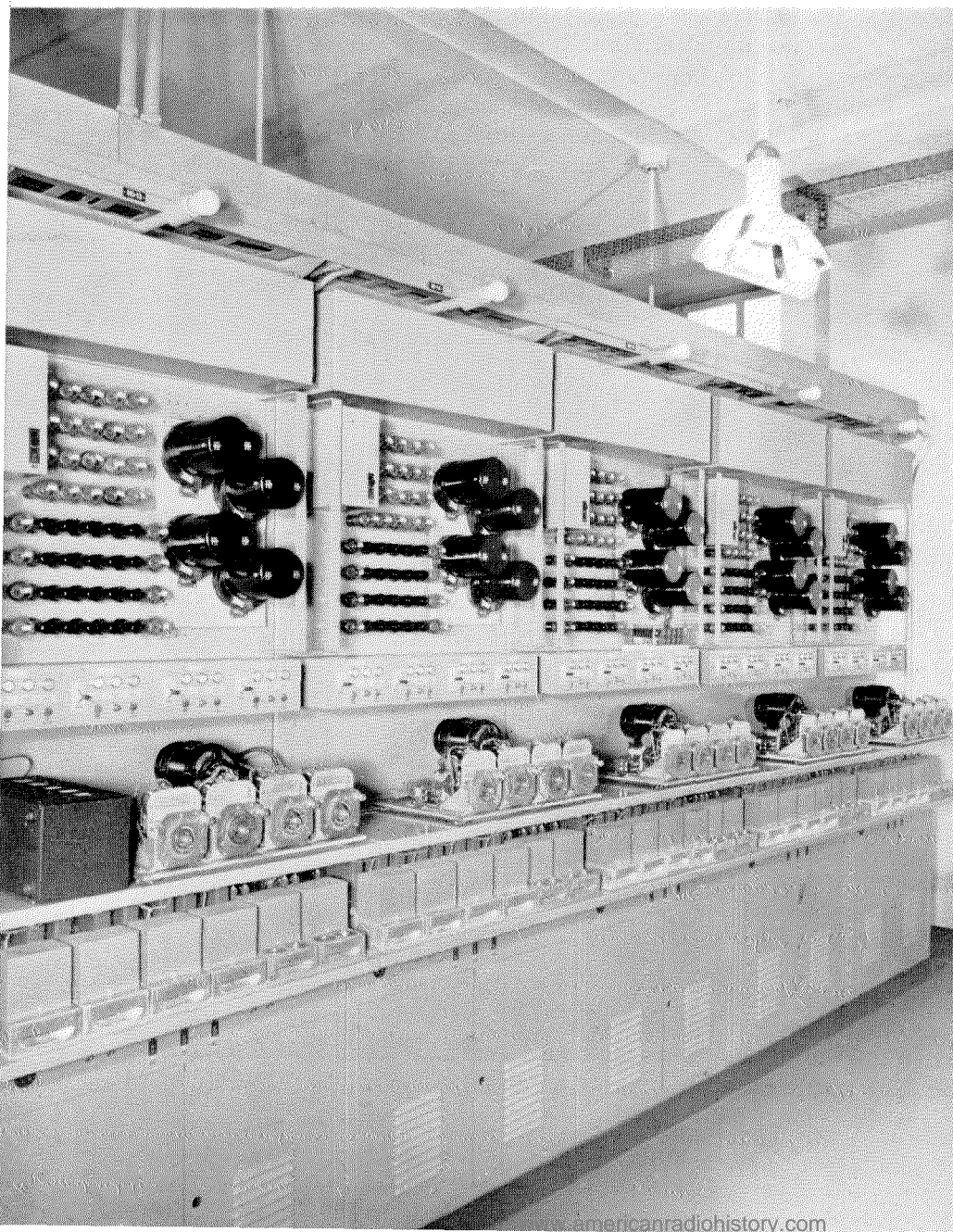

over the receiving leg, the flow of current through the receiving relay is interrupted and the start magnet of the receiving distributor releases the brushes, which move over the pulse segments in synchronism with the transmitting distributor at the out-office, applying either a positive or negative potential to the grids of the tubes in conformance with the marking or spacing pulses received. The contacts of the five plate-circuit relays act as an intraoffice transmitter to set up the code combination for sending into the intraoffice reperforator.

A view is shown in Figure 10 of the racks mounting the receiving distributors that convert from one code to the other. The face-plate distributors are shown in groups of 4 per rack. These units are concentrated so that a large number of out-offices are served by a relatively small number of receiving distributors, generally in the ratio of 3 out-offices to one distributor.

Figure 11 shows six sending positions mounted on three racks. Each position includes a reperforator for perforating the messages received from push-button and tributary offices and a tape transmitter for sending these messages to the destination with which the sending position is associated. The automatic message-numbering machines, which insert the channel designations and message numbers ahead

Figure 11—Each sending position consists of a reperforator and a transmitter. The automatic numbering machines are mounted at the top of the racks.

of individual messages, are shown at the top of the racks.

### 5.3 INTRAOFFICE CIRCUIT

A schematic diagram of the intraoffice circuit is shown in Figure 12. The intraoffice transmitter is shown at the right of the diagram. Its 5 information pulse circuits and its transmitter step pulse circuit are connected through a 10-level connector switch and the selector magnets of the intraoffice reperforator at the sending position to a motor-driven impulse unit, which is shown at the left of the diagram.

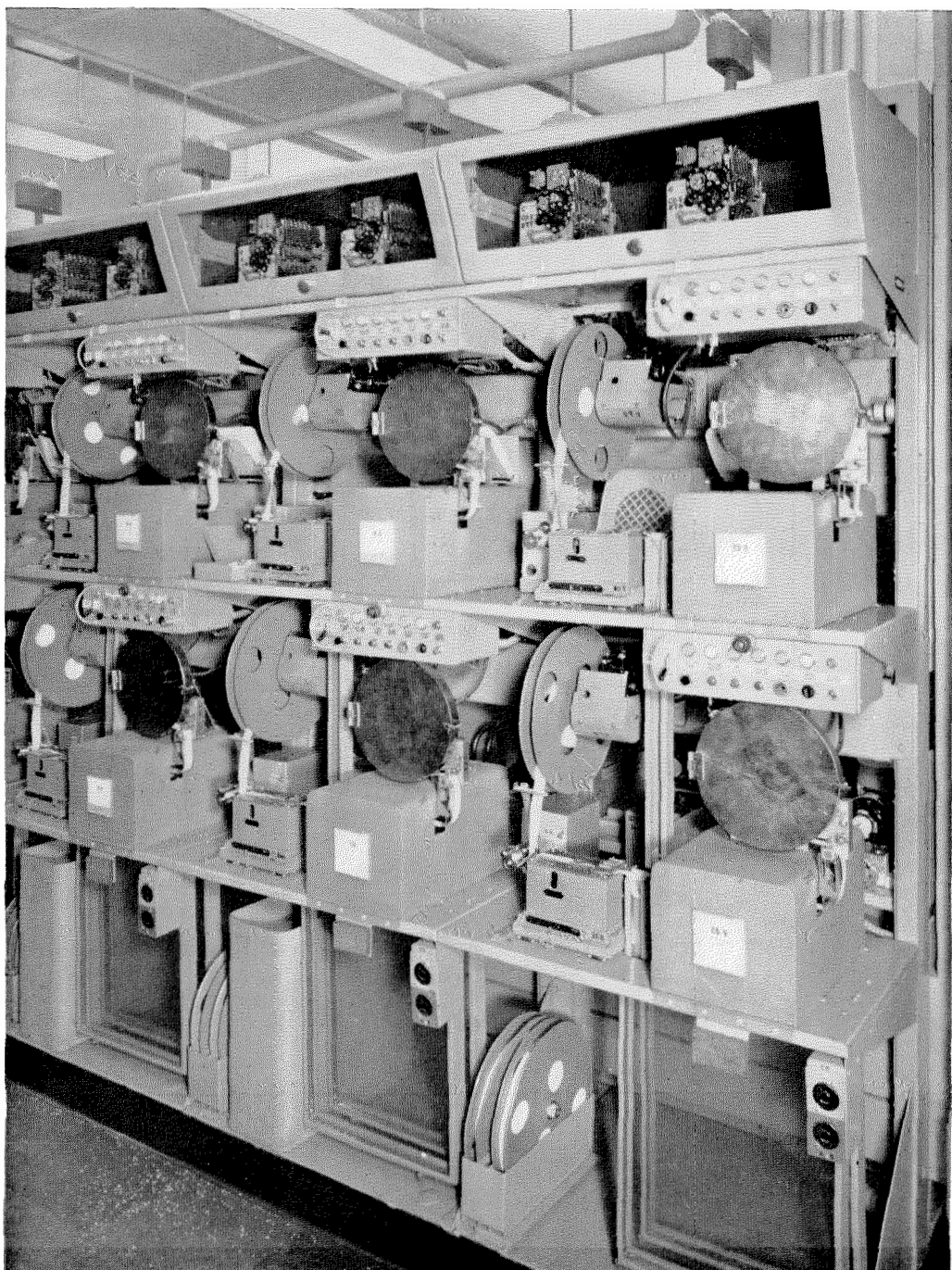

The 7 contacts on the impulse unit control the operation of the selector magnets of the reperforator, the punching of the perforations in the tape, and the stepping of the intraoffice transmitter.

The timing of these impulse-unit contacts is shown in the upper right-hand corner of the diagram. The timing chart is based on a speed of 150 words per minute. The time required for the transmission of one character at this speed is 66.6 milliseconds.

The number is inserted by the automatic numbering machine immediately after a connection has been made to the intraoffice reperforator and while the number-inserting relay is released and its back contacts are closed. After the numbering machine has transmitted the sequence number, the relay is operated and transfers the step pulse circuit to the intraoffice

transmitter, which then proceeds to send the message.

### 6. Identification of Messages

In handling commercial telegrams, unrelated and relatively short messages are transmitted, one after the other, over the telegraph circuit. In manual operation, each telegram was placed under a numbering stamp that imprinted on the blank the call letters of the distant office, channel designation, and channel sequence number for that message.

When the sending operator prepares a message for transmission under the present method, she prefixes it with her office call letters and with the channel designation and sequence number that were placed on the blank by the numbering stamp. At the receiving end of the circuit, the

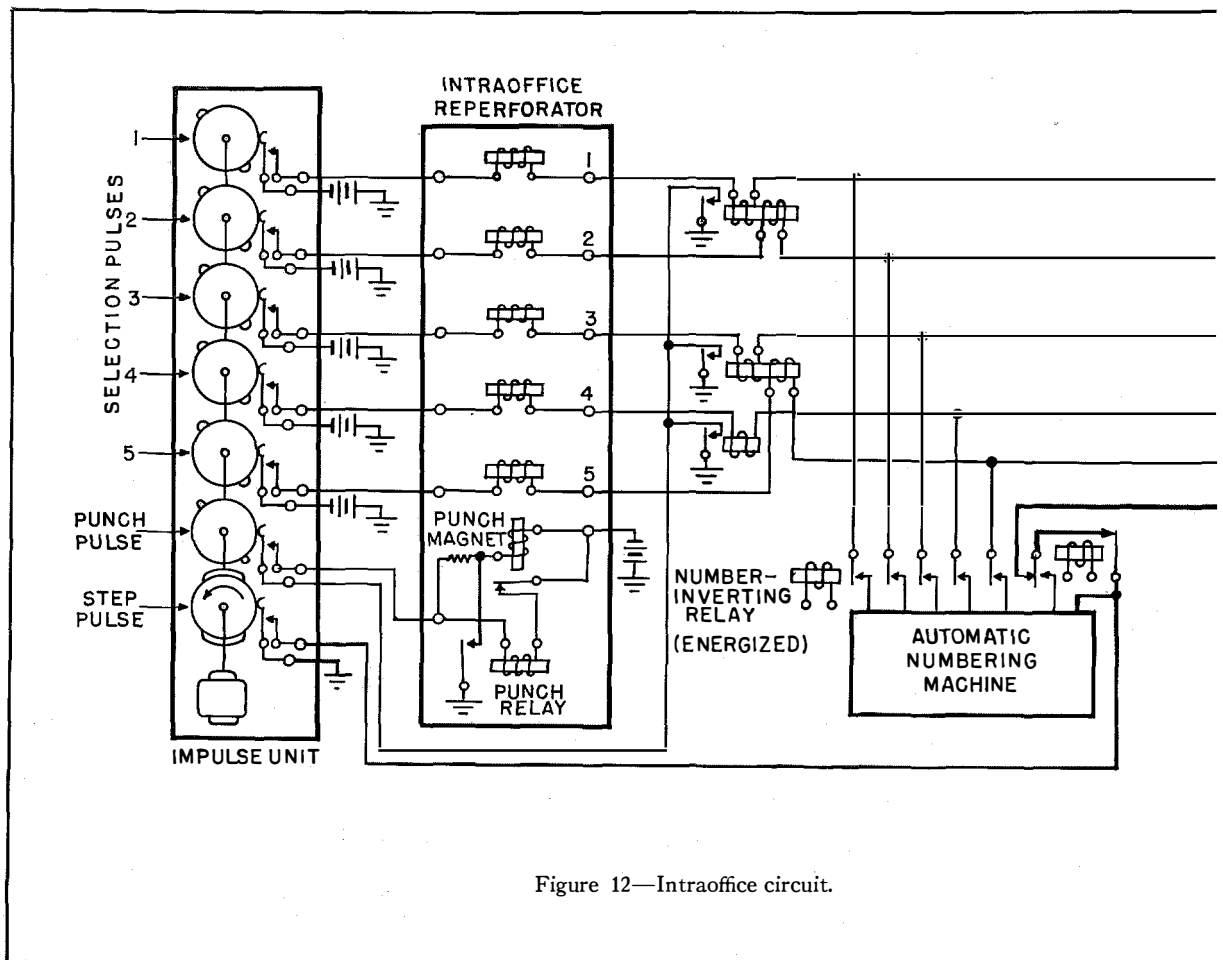

Figure 12—Intraoffice circuit.

receiving operator checks off on a tally sheet the sequence number of each received message and becomes immediately aware of omitted or duplicated numbers.

Prefixing messages with call letters and the channel sequence numbers provides the means of identifying any particular message. This is of value when a receiving office wishes to query a sending office on a specific message or when a receiving office indicates at which point transmission is to be resumed after any interruption of service.

In automatic switching, most telegrams pass through the switching centers without manual supervision. Consequently, it is necessary to provide automatic facilities for checking message sequence numbers. These facilities insure that all telegrams transmitted to the switching center have been received and that all characters of the

preamble consisting of office call, channel designation, and message number have been performed correctly at the line sending position. If this preamble is not received correctly, further transmission is stopped, the received portion of the message is automatically cancelled, and the originating office is signalled to examine and retransmit the message. Making certain of the accuracy of the preamble of each message permits tracing any message even though equipment or line trouble should cause the remainder of it to become mutilated or lost.

Each office within an area starts a new sequence of numbers every 24 hours. On arrival of a message at the area center, the sequence number is checked automatically by comparing it with a "sequence-number indicator," a group of which may be seen in Figure 13.

The sequence-number indicator is stepped up

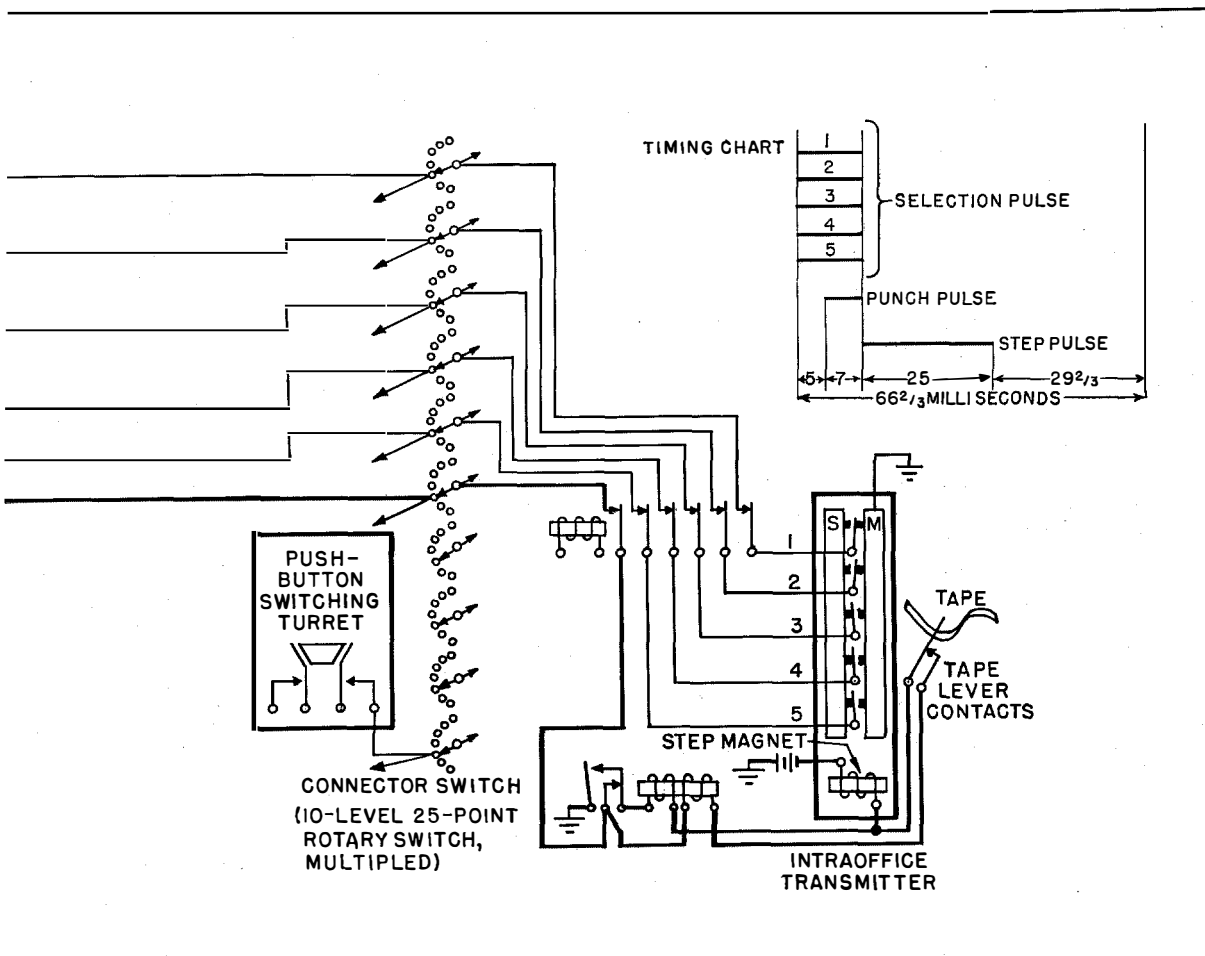

one number for every received message. The number is set up visually for the supervisor and electrically for comparison with the next transmitted number.

The checking of the preamble of each message takes place while the preamble and the first few characters of the message are being received and reperforated at the selected line sending position.

The intraoffice reperforator at the line sending position is equipped with readback feeler pins similar to the selecting pins on a tape transmitter. While a reperforator is punching code combinations in the tape in response to incoming signals, the readback feeler pins are reading a code combination that has been punched in the tape.

The readback feeler pins actuate contacts that transmit this code combination back over the 5 wires of the intraoffice circuit to comparison equipment.

Let us assume that Concord, New Hampshire, has a telegram for Niagara Falls, New York. Concord terminates in a line finder at Boston, while Niagara Falls is in the area served by Syracuse, New York. The message from Concord will be preceded by the following characters.

**SY space B.COA figure shift 036**

The first two letters are the selection characters for Syracuse. *B*, for Boston, is the call letter of the area that serves Concord. The following period is a separation character. *CO* are the call letters of the Concord office. *A* represents the *A* or first channel between Concord and Boston. The figures *036* indicate that the message is the 36th to be sent from Concord over channel *A* that day.

When the Concord operator has prepared the message in tape form, she initiates a request for connection to the Boston switching center by depressing a push button. A spacing signal is sent over the line to Boston. The Boston line finder responds and connects Concord to an idle receiving distributor, which in turn requests an automatic switching unit. When an automatic switching unit, which serves 11 other receiving distributors, answers the request, a stop is placed on message transmission to the Concord office so that the send-



Figure 13—Racks of sequence-number indicators.

ing channel may be used for a control signal. *Go-ahead selection* signal is then sent over the sending channel after which regular message transmission is resumed.

This spacing signal is read by an electronic timing device at the Concord office and the transmitter there is started. The transmitter is arranged to step the tape until it reaches the first space character. Therefore, the selection characters *SY* and the following *space* character are transmitted before the transmitter stops.

The automatic switching unit reads and stores these selection characters and then sets up a connection to one of the idle channels of the Syracuse trunk circuit. On establishment of the connection, the automatic message-numbering machine at the Syracuse line sending position transmits the channel sequence number to the intraoffice reperator.

Following the operation of the numbering machine, another *go-ahead* spacing signal is sent to Concord. The reception of this signal restarts the Concord transmitter. Since the characters *SY* and *space* have already been sent, resumption of transmission will start with *B.COA figure shift 036*, followed by the message.

While the intraoffice reperator is punching the received code combinations in the tape, the readback feeler pins are reading the code combinations that have already been punched in the tape. Each of the readback code combinations, except for the hundreds digit, is compared, respectively, against the code combinations for the nine characters *B.COA figure shift 036* set up in a sequence-number indicator associated with the Concord receiving channel. If a correct comparison takes place on all characters in the preamble, the sequence-number indicator is stepped up one digit to be in readiness for the next message, while transmission from Concord continues.

The two periods that terminate the message are read both at the Concord office and the Syracuse sending position. The transmitter at Concord automatically stops on the two periods. The reading of the two periods at the switching center disconnects the receiving distributor thus permitting the Syracuse sending position to accept another message.

As the intraoffice circuit becomes disconnected, a 2-second disconnect signal is sent to the Con-

cord office to indicate that the reception of the message has been completed.

The message is received at Syracuse in a printer-perforator in the push-button switching aisle. The switching clerk at Syracuse presses the Niagara Falls destination push button. The message is then transmitted across the office to the Niagara Falls sending position from which it is sent automatically to the Niagara Falls office.

### 6.1 WRONG COMPARISON

If any of the first nine characters of the message fail to compare with the characters set up in the sequence-number indicator, a wrong-comparison condition is established. The message is not accepted at the switching center and the sequence-number indicator is not advanced to the next number.

A 2-second spacing signal is sent to the Concord office stopping the transmitter there. Since this 2-second spacing signal has been received before the out-office transmitter has read 2 periods, it indicates that a wrong comparison has taken place at the switching center and a *resend* signal lamp is operated. The Concord operator then inspects the preamble of the message to determine the reason for the wrong comparison, makes any necessary corrections, and resends the message.

As a result of the wrong-comparison condition, the receiving distributor at the switching center makes a request for a *bust this* unit that serves 24 receiving distributors. This unit sends to the intraoffice reperator on the Syracuse line sending position the words *bust this* followed by 2 periods, thus informing the Syracuse office that the trunk channel sequence number is to be cancelled. The 2 periods serve as a disconnect signal and free the Syracuse sending position for other messages.

This checking of call letters and sequence numbers is done automatically. It is, therefore, desirable when a wrong comparison occurs to determine whether the comparison equipment is functioning correctly. This is done by having the readback contacts on the reperator send back to the *bust this* unit the code combinations perforated in the tape.

If the comparison is correct, the intraoffice connection is released. However, if a wrong

comparison occurs on any of the characters, the intraoffice connection is maintained and signals are operated to call supervisory personnel. The receiving distributor and sending position are not restored to service until inspected and manually released.

### 7. Alarm Circuits

Where an out-office operates directly with a line sending position through switching equipment that is shared by a large number of out-offices, it is naturally undesirable that any of this

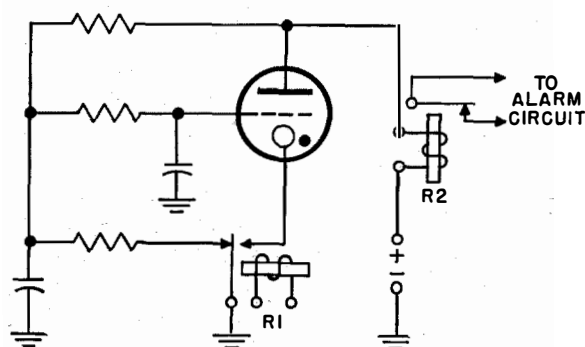

Figure 14—Timing circuit for operating alarm signals. The 20-microfarad capacitor is at the lower left.

common equipment be held longer than is necessary in the switching of a message. Trouble-detecting facilities are, therefore, provided and include the following.

If a line finder has a call registered but unanswered for three seconds, a trouble signal is operated, calling an attendant.

When a receiving distributor connects to a calling channel and makes a request for an automatic switching unit, the request must be answered within three seconds or the trouble alarm is operated.

When a receiving distributor connects to a calling channel, a *go-ahead* signal is sent to the calling office. If no characters are received within five seconds, a 2-second resend signal is automatically transmitted to the out-office, after which the receiving distributor is disconnected from the calling channel. This feature prevents false calls from tying up automatic switching facilities.

Figure 14 shows a typical alarm circuit for calling supervisory attention in the case of an abnormal delay in operation. In this case, assume that the circuit has been set up to include the operation of relay *R1*, shown at the bottom of the sketch. This operation removes the ground from the 20-microfarad capacitor and also closes the cathode circuit of the cold-cathode tube directly above it. After a period of time, controlled by the charging rate of the resistance-capacitance circuit, the voltage on the starter anode reaches a value that fires the tube. Relay *R2* operates and sets off the supervisory alarm. A supervisor then takes routine action to protect the message in transit.

## Fifteenth Plenary Assembly of the Comité Consultatif International Téléphonique, Paris, 1949

THE LEGENDS for figures 2 and 3 were transposed in the above paper, which appeared on pages 87 through 100 of the June, 1950, issue (volume 27, number 2) of *Electrical Communication*.



## Portable Microwave Television Link

FROM ANCIENT TIMES, the short channel crossing between Dover and Calais has been used for the communication link between England and the Continent. The early Romans set up their heliographs on the cliffs at Dover and some twenty centuries later, using electromagnetic waves of greater length but still substantially obedient to the laws of optics, the first microwave radiotelephone link<sup>1</sup> was demonstrated. Later, commercial microwave service<sup>2</sup> was initiated between the civil airports at Lympne, England, and St. Inglevert, France. These early results were significant steps in a microwave research and

development program that has assumed increasing importance with the advent of television broadcasting; the very wide band of frequencies that must be transmitted to reproduce a television picture makes the use of microwave carriers compulsory.

In addition to the normal broadcasting feature in television, there is the problem of picking up programs at places outside of the regular studios and sending the resultant video-frequency signals to the broadcast transmitter. Coaxial cables will carry these television signals but they are too expensive for infrequent use. This has resulted in the application of radio for linking outside-broadcast pickup points with the transmitter either directly or through the studio and its permanent coaxial circuits to the transmitter.

Top of page—Microwave equipment installed at Dover.

<sup>1</sup> "Micro-Ray Radio," *Electrical Communication*, v. 10, pp. 20-21; July 1931.

<sup>2</sup> A. G. Clavier and L. C. Gallant, "Anglo-French Micro-Ray Link Between Lympne and St. Inglevert," *Electrical Communication*, v. 12, pp. 222-228; January, 1934.



The modern trend for these radio links is toward compact, light-weight, portable equipment suitable for field use. By mounting the transmitter at an elevated point, the line-of-sight distance to the receiver can be increased greatly beyond that of ground-level equipment and the



The transmitting circuits are enclosed in the weather-proof cannister above the 4-foot paraboloid, which is being aimed at a distant receiver.

power may be substantially reduced without failure of the circuit due to noise.

On August 27, the British Broadcasting Corporation presented its first television event picked up from the Continent. Fittingly enough, the celebrations in Calais marking the centenary of the first cross-channel submarine cable were the subject of this first cross-channel television broadcast.

The program was picked up at Calais and from a tower some 200 feet above ground was projected across the Strait of Dover to a receiver also mounted on a tower. Three more radio links were used to bring the signals to London at which point they were introduced into the coaxial network that connects to the

Alexandra Palace and Sutton Coldfield transmitters. The distance from Calais to Alexandra Palace is approximately 95 miles and the longest hop was that across the Strait of Dover.

The television link equipment supplied by Standard Telephones and Cables for this broadcast constitutes a frequency-modulated system employing transmission frequencies of the order of 4000 megacycles per second. When two or more links are operated in tandem, the incoming signals are demodulated and transferred to a transmitter working at a frequency that differs from the received signal by 40 megacycles to prevent mutual interference.

The complete mains-operated transmitters and receivers are assembled in a number of small portable units. Except for semipermanent receiving terminals, the equipment is designed for use in a motor van. A 4-foot paraboloidal reflector, together with a weatherproof cannister in which either receiving or transmitting equipment is enclosed, may be mounted on the roof of the van for short transmission paths or placed at some advantageous elevated place for communication over greater distances.

The receiving or transmitting equipment in the cannister is connected to the paraboloid through a rectangular waveguide having a cross section of 2 inches by  $\frac{2}{3}$  inch and terminating in an electromagnetic horn, the aperture of which is located at the focal point of the paraboloid.

A separate transmitter control unit is normally located in the van. It includes a cathode-ray-oscilloscope monitor and a power supply. The transmitter unit in the cannister accepts a 1-volt peak-to-peak picture signal from a 75-ohm coaxial cable. After passing through a 2-stage amplifier, it is applied to the modulator electrode of a coaxial-line super-high-frequency oscillator, which utilizes a valve of the velocity-modulated type.

The transmission frequency is set approximately by adjustment of a piston in a calibrated cavity resonator, which permits a tuning range of 100 megacycles. Fine adjustment of frequency is achieved by varying the mean potential of the resonator.

A small sample of the 300 milliwatts of radiated power is applied to a silicon detector, amplified, and transferred over a coaxial cable to the monitor unit to furnish a measure of the

radiated power. The deviation of the modulator can be adjusted to be 2, 4, 6, or 8 megacycles over a bandwidth of 15 megacycles.

For receiving, the cannister contains a local oscillator of the coaxial-line type operating, like the transmitter, on a maximum of 250 volts. A crystal mixer combines the incoming signal and the locally generated wave to produce an intermediate-frequency signal at 60 megacycles. After passing through a 3-stage amplifier, using a grounded-grid triode, it is carried to the associated circuits in the van over a coaxial cable. It then goes to a 7-stage intermediate-frequency amplifier, a discriminator, and a power output unit.

The 7-stage intermediate-frequency amplifier employs stagger tuning and produces a gain of 65 decibels over a 14-megacycle band. It delivers about 1 volt of signal, which is amplitude limited and then discriminated in the conventional manner. After further amplification, the video-frequency signal is available as a 1-volt signal in the 75-ohm output circuit of a cathode-follower.

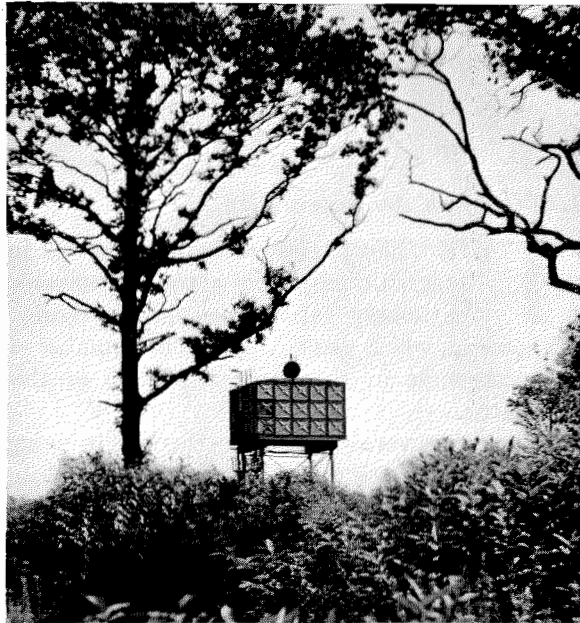

One of the relay points showing the transmitter atop a water tower at Harvel in Kent.

The system is flat from 25 cycles to 5 megacycles and is more than adequate for the British 405-line 50-frame transmissions.

In the discriminator circuit, positive- or negative-going video-frequency signals can be selected by push button irrespective of the sense of the intermediate-frequency deviation. A meter indicates the mean intermediate frequency so that knowing the magnitude and sense of deviation, the receiver may be adjusted to give the correct discriminator excursion.

When setting up a link, the oscillators are first adjusted to their nominal frequencies by means of the tunable cavities. The resonator potential of the local oscillator in the receiver is then adjusted to produce a frequency giving maximum signal output. After a brief warming-up period, the frequencies will remain satisfactorily stable for the duration of a broadcast. Any change in frequency can be observed on the meter that indicates the crystal current of the mixer in the receiver. Minor adjustments may be made even during transmission.

The paraboloids, which concentrate the fields in an area about 5 degrees across, are set up with the aid of a map and a compass. Slight horizontal adjustment and variation of the elevation of the paraboloid may be required for optimum results.

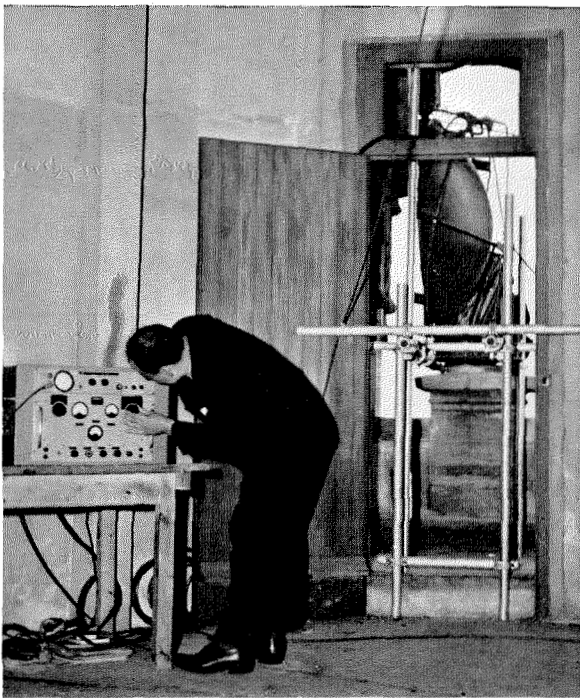

Portable microwave transmitter and associated equipment installed at Calais, France, for the first television program from Europe to be broadcast by the Alexandra Palace and Sutton Coldfield transmitters of the British Broadcasting Corporation.

# Feedback in Magnetic Amplifiers\*

By ALAN S. FITZGERALD

*Electrical Research Engineer, San Francisco, California*

## 1. Feedback Arrangements

THE USE of regeneration or feedback in magnetic amplifiers gives rise to some extremely interesting and intriguing phenomena, which can be applied in a number of different ways in the design and use of this apparatus.

There are several different methods of bringing about the feedback effect by both direct and indirect means. For example, an additional direct-current saturating winding may be connected in series with the rectified output of the amplifier,<sup>1</sup> or a resistor carrying the output current may be included in the input circuit.<sup>2</sup> There are various other arrangements by means of which the direct-current magnetomotive force applied to the core of the saturating reactor† may be augmented in accordance with the amount of the magnetic-amplifier output.

The simple series winding is the least complicated arrangement to illustrate and to describe and explain. Accordingly, this method will be adhered to in the present paper. Other equivalent or analogous arrangements may, of course, be employed when these alternative methods may be convenient or advantageous.

\* Reprinted from *Journal of The Franklin Institute*, v. 247, pp. 223-243 and pp. 457-471; March and May, 1949, respectively.

<sup>1</sup> Dowling, United States Patent 1,739,579.

<sup>2</sup> FitzGerald, United States Patent 2,464,639.

† For the convenience of the reader, the following description of the action of the saturating reactor is abstracted from a previous paper<sup>3</sup> by the author.

A saturating reactor (Figure 1) consists of two electromagnetic circuits, one carrying alternating and the other (input) direct current. Part of the magnetic circuit is common to both fields. With the input circuit disconnected, the alternating-current winding acts like the primary of a transformer with an open-circuited secondary; its impedance is high and only a small current flows. When the direct-current winding is energized, the flux density in the core increases, the impedance of the alternating-current winding is reduced, and the current in that winding becomes larger. By arranging the alternating-current winding in two halves with opposing magnetic fields, no voltage is induced in the input winding as a result of transformer action.

<sup>3</sup> A. S. FitzGerald, "Magnetic Amplifier Circuits Neutral Type," *Journal of The Franklin Institute*, v. 244, pp. 249-265; October, 1947; see Figure 11.

A single magnetic-amplifier element or stage is shown in Figure 1. Such an arrangement is of the neutral type; that is to say, its response is independent of the polarity of the input current. The addition of the series or feedback winding is illustrated in Figure 2.

Several qualitatively different types of action result, in accordance with the quantitative extent to which the feedback effect is introduced.

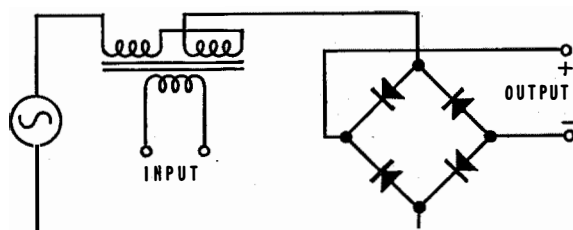

Figure 1—Neutral type of magnetic amplifier.

The amount of feedback will obviously depend on the number of turns of the series winding. But this is not the only significant element involved. The resistance of the output circuit is equally pertinent. The higher the value of the

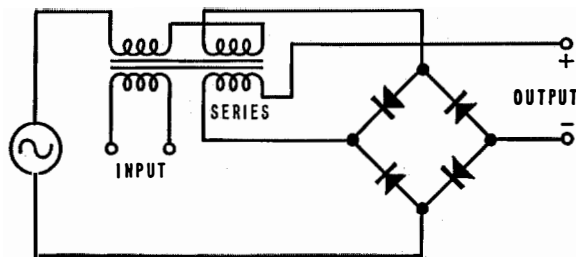

Figure 2—Magnetic amplifier with feedback (series) winding.

output-circuit resistance, the less output current we shall get. Clearly, it is the amount of ampere-turns that are set up by the series winding that in the last analysis determines the magnitude of the feedback that results.

In this connection, we must not overlook the

fact that the rectifier comprises a portion of the output-circuit resistance. Furthermore, the efficiency of rectification is an element in the amount

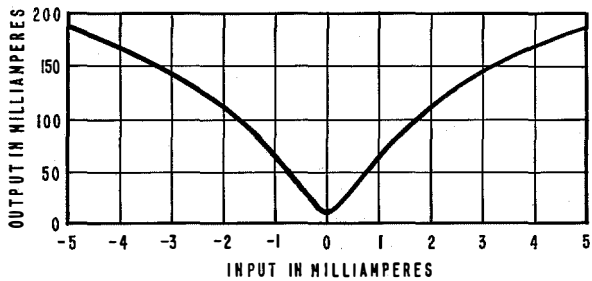

Figure 3—Response characteristic of neutral amplifier.

of the feedback effect. Thus, in a magnetic amplifier, changing one rectifier for another will sometimes cause an increase or a decrease in the feedback. Also, the fact that the rectifier characteristics are nonlinear introduces a complication in the prediction of the results of the use of any given feedback structure.

If we plot a curve showing the relation between the input and output currents for the circuit of Figure 1, showing both positive and negative input values, we obtain a result such as is shown in Figure 3. The curve is seen to be symmetrical about the zero axis; that is to say, the amplifier is of the neutral type.

If similar curves be obtained for the series feedback arrangement of Figure 2, it will be found that, in accordance with the amount of feedback employed, the resulting action will exhibit three separate and distinct phases or characteristic types of response. These may be described, respectively, as:

- A. Unitary or singular stability.
- B. Binary or plural stability.
- C. Absence of stability—resulting in a floating condition.

1.1 SINGULAR STABILITY

Figure 4 shows a curve of the same type as that of Figure 3, when the circuit has the following characteristics:

- A. The number of turns of the series or feedback winding is not more than one-half of the total number of turns in series with the alternating-current winding. For example, in Figure 4 the total alternating-current turns are 430 and the series turns, 200.
- B. The total resistance of the output circuit, exclusive of

the rectifier, is such that, in the absence of any feedback, that is to say, if the circuit is as in Figure 1, the current flowing therein is reduced to approximately 75 percent of the value that occurs when there is no additional circuit resistance.

The total circuit resistance is maintained at this constant value in all of the curves of Figures 3 to 12, inclusive.

While the phenomena to which this paper has reference have no more relevance to communication technology than to any other field of study, it is possible that the text may be somewhat more concise if we may refer to the application of input current, power, or excitation, by the conventional expression "signal." When the input excitation is additive, in relation to the feedback winding ampere-turns, we shall refer to the signal as being of positive polarity. When the input opposes the series winding, it will be designated as a negative signal.

In Figure 4, it is immediately evident that the circuit of Figure 2 responds in a different manner to a negative signal than is the case when the polarity of the signal is positive. The curve of Figure 4, unlike that of Figure 3, is not symmetrical about the zero axis. With a positive signal, the effect of the feedback is to increase the current to a value greater than that obtained

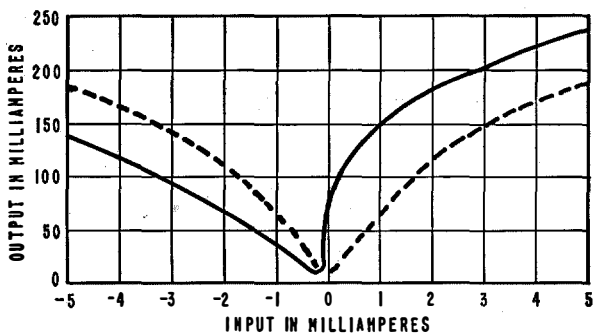

Figure 4—Response characteristic of feedback amplifier with a series winding of 200 turns.

with the circuit of Figure 1. When the signal is negative, the current is decreased. To bring out more clearly the extent of this difference, the neutral-type curve of Figure 3 is repeated again in broken lines in Figure 4.

For any number of series turns less than 200, the figure to which Figure 4 relates, other curves

may be plotted and all of these curves would lie between the full-line and broken-line curves shown in Figure 4.

For all such values of series turns, the condition of singular stability will obtain. That is to

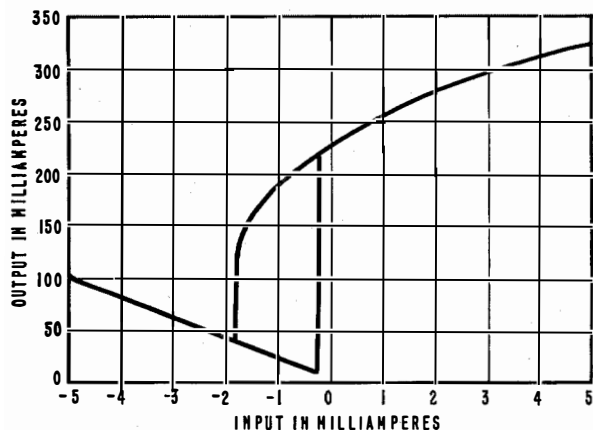

Figure 5—Response characteristic of feedback amplifier with a series winding of 450 turns.

say, if a signal of either positive or negative polarity be applied, a resulting change will take place in the output current, as long as the signal is maintained; but when the signal is withdrawn, the output current will revert to exactly the value previously existing.

## 1.2 BINARY STABILITY

If the number of series turns be increased to a figure approximately double the previous value, so that the feedback turns are of the same order of magnitude as the total number of the alternating-current turns in series, we obtain the very interesting result shown in Figure 5. This is a curve of the same general type as in Figure 4 when the series winding consists of 450 turns.

The significance of this curve illustrating binary stability can perhaps be explained most simply if we may follow the action of this circuit through a cycle of operation. Suppose, for example, that initially the circuit receives a negative signal of 5 milliamperes. If we observe the reading of an instrument that indicates the output current, we shall note that its pointer will be stationary at a reading of 100 milliamperes. Conditions will be entirely stable.

Suppose, now, we slowly reduce the value of

the negative signal. We shall observe that the output current will likewise be commensurately decreased. For example, at a signal of  $-3$  milliamperes, we shall note an output current of approximately 60 milliamperes. The circuit continues to remain in a condition of stability.

However, if we slowly reduce the signal further, at a value of about  $-0.25$  milliamperes input, a sudden discontinuity phenomenon will manifest itself. The pointer of the output current milliammeter will suddenly jump from a value of 10 to a value of nearly 220 milliamperes. At this value, a second range of stability now obtains. If the signal be further adjusted in the same direction, that is to say, in the positive sense, the output current will increase as the positive signal is increased and the condition will be one of stability; if the signal be withdrawn and re-established the same value of output current will ensue, in accordance with Figure 5. Thus, for example, if the signal be  $+3$  milliamperes, the output milliammeter will indicate 300 milliamperes.

Now suppose we adjust the signal in the opposite sense—towards negative values. The output current will, in accordance with the curve, decrease as the signal is reduced. When the signal is reduced to zero, the output current will be 225 milliamperes; but when the signal reaches the value of  $-0.25$  milliamperes, the action obtained with increasing signal values will not be repeated in reverse. The second, or upper, range of stability will be maintained for negative signal levels beyond the value of  $-0.25$  milliamperes. The cir-

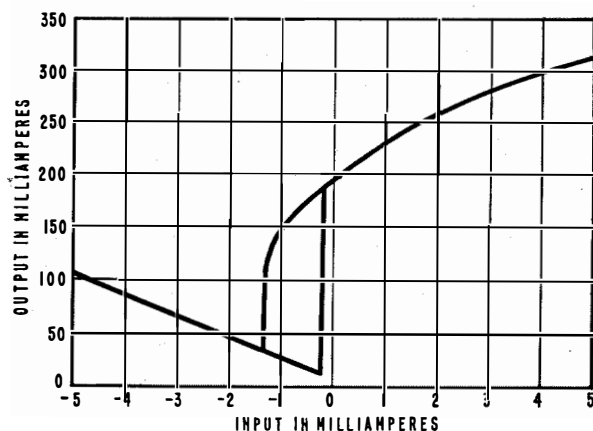

Figure 6—Response characteristic of feedback amplifier with a series winding of 400 turns.

cuit will not transfer to the lower range of stability until a signal of  $-1.8$  milliamperes is reached. At this value a similar discontinuity condition occurs and the lower range of stability is resumed. It is to be noted, however, that the trans-

ferent necessary to bring about transfer from one range of stability to the other, to the resulting change in output current, which is a quantity related to the gain, is increased by reducing the amount of feedback.

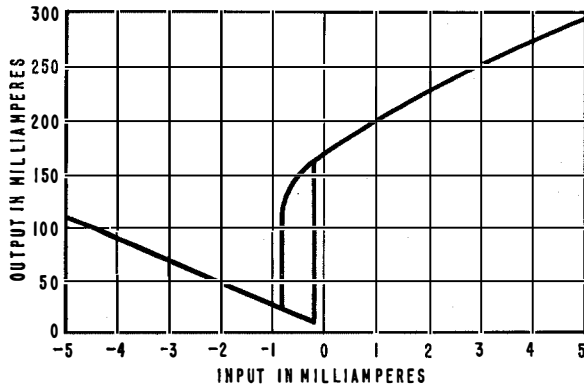

Figure 7—Response characteristic of feedback amplifier with a series winding of 350 turns.

fer to the lower range is less abrupt than that which takes place at  $-0.25$  milliamperes signal when the signal is adjusted in the positive direction. In this latter case, the action is very sharply defined and there is no indication, when watching the pointer of the output meter, of the approach to the critical point. When adjusting the signal in the negative direction, however, as is indicated by the shape of the curve, the point of discontinuity is approached more gradually, and the impending sudden switch from the upper to the lower stability ranges is preindicated by the action of the instrument pointer. Thus, when the signal reaches the value of  $-1.8$  milliamperes, the output current falls from a value in the neighborhood of 130 to 40 milliamperes, corresponding with the lower portion of the curve originally traversed when the signal was adjusted from  $-5$  milliamperes in the positive direction. If the signal now be restored to the latter value, that is to say,  $-5$  milliamperes, the output current, as before, will again be 100 milliamperes. The circuit will be in a condition of complete stability, in the lower of the two ranges.

Figure 6 shows a similar curve for 400 series turns, and Figure 7 shows the action obtained when the series turns are 350.

It is of special interest to note in Figures 5, 6, and 7, that the ratio of the change in input cur-

### 1.3 FLOATING ACTION

By selecting a number of turns for the series winding somewhere in the range of from 60 to 75 percent of the alternating-current turns, a completely different characteristic or action pattern results. This is illustrated in Figure 8 in which the number of series turns is 300.

As is foreshadowed by the results indicated in Figures 5, 6, and 7, the loop is now completely closed and the relation between the input and the output currents is now exactly the same whether the input be varied from positive to negative or in the opposite sense.

It is evident from Figure 8 that when the input is around  $-0.4$  milliamperes, at which value the curve has a section that is vertical, an extremely small positive or negative increment in the signal will result in a substantial change in the value of the output current. In other words, the circuit under these conditions is capable of manifesting an exceptionally high gain.

This special condition is accompanied by a most interesting phenomenon, which may be most usefully applied in the development of magnetic amplifiers. When the circuit constants are adjusted to exactly the proper values, the output current, with a signal of fixed and finite magnitude, is of indefinite and indeterminate value between the limits of 10 and 110 milliamperes.

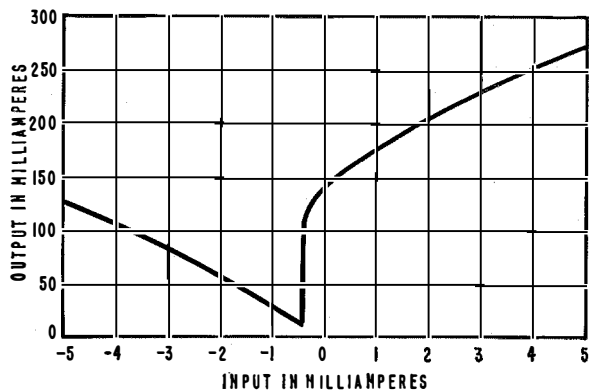

Figure 8—Response characteristic of feedback amplifier with a series winding of 300 turns.

Under these conditions the pointer of the output milliammeter manifests an apparent behavior almost identical with that of an instrument of the uncontrolled type such as a flux-meter. That is to say, in the absence of any constraining signal effect tending to increase or decrease the output current, it tends to remain for quite a prolonged period at any value between the above limits at which it may have been positioned.

When this condition exists, the output current is capable of being controlled or modulated, by some external or separate agency that can furnish an appropriate signal, to any value between the maximum and minimum values embraced by the vertical section of the curve in Figure 8.

This characteristic is one of the most important and valuable features of the use of feedback in magnetic amplifiers and the manner in which it may be applied will be described in greater detail below.

#### 1.4 BIAS WINDING

It will be noted on referring to all of the foregoing curves with the exception of Figure 3, that the most interesting relation between the input current and the output current obtains at a signal level other than zero. For example, in Figure 4, with a zero signal the output current is 70 milliamperes, whereas in Figure 3 in which there is no feedback, the current with a zero signal is 10 milliamperes. This, of course, is due to the fact that the  $I_0$ , or residual magnetizing current, which has a value of 10 milliamperes as seen in Figure 3, flows in the series winding, thereby increasing this value by cumulative action from 10 to 70 milliamperes.

This increased value of  $I_0$  is undesirable because, if the output of the circuit is to be applied to a second stage, it will be necessary to annul or compensate for this higher value instead of 10 milliamperes and this is likely to result, in one way or another, in a reduction in the gain of this second stage. For example, if the second stage comprises a compensating winding of the type described in a previous paper,<sup>3</sup> such a winding would require more ampere-turns if it be necessary to compensate for 70 than for 10 milliamperes, as a result of which the compensating winding would occupy a larger portion of the window area of the core punching thus leaving

less available for the second-stage input winding, which would result in reduced gain.

Furthermore, since the slope of the curve in Figure 4 decreases with increase in the positive signal, the higher the value of the residual cur-

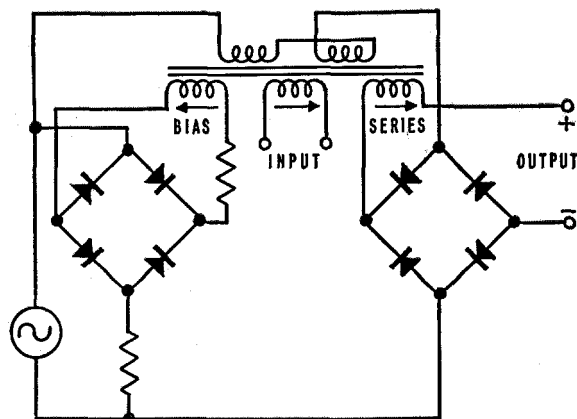

Figure 9—Magnetic amplifier with feedback (series) and bias windings.

rent, the less will be the sensitivity; that is to say, the amount of the change in the value of the output current that results from a given signal increment. For example, in Figure 4, it is seen that if we increase the signal from zero to +0.2 milliamperes we cause the output to increase from 70 to 100 milliamperes, a net current gain of 30 milliamperes. But if, instead of changing the signal from zero to +0.2 milliamperes, we change it from -0.2 milliamperes to zero, we obtain a resulting output current change of from 10 to 70 milliamperes, which gives us a difference of 60 milliamperes.

Accordingly, whenever a series feedback winding is employed, it is desirable to provide also an additional bias winding, referred to in a previous paper<sup>4</sup> and carrying a current of appropriate and constant value. This winding opposes the excitation of the series winding due to the  $I_0$  or normal residual current.

Figure 9 shows a single magnetic amplifier element with both a feedback and a bias winding. The latter is supplied from the alternating-current source through an additional rectifier and resistors of the proper value for furnishing the amount of excitation required.

<sup>4</sup> A. S. FitzGerald, "Magnetic Amplifier Characteristics Neutral Type," *Journal of The Franklin Institute*, v. 244, pp. 415-439; December, 1947; see Figure 2.

By adjusting the value of the bias current, it is possible to reduce the value of the output current, when the input signal is zero, to the same value as in Figure 3, which is 10 milliamperes. That is to say, the curve shown in Figure 4, which reaches its minimum value with an input of  $-0.2$  milliampere, may be displaced laterally so that the minimum comes at zero input as shown in Figure 10. A signal of  $+0.2$  milliampere will now raise the output current from 10 to 70 milliamperes, an increase of 60 milliamperes.

However, it is not necessarily always desirable to use a bias current that gives minimum  $I_0$  at zero input. It is found in practice that a slightly lower value of bias current is usually to be preferred such that the output current at zero input may be slightly greater than the minimum value. Clearly, the optimum value of the bias current will be that at which the slope of the curve is a maximum where it intersects the input zero axis, since this will give the maximum change in output current with an input signal of low value. For example, in Figure 10, if the bias current be adjusted so that the minimum value of 10 milliamperes occurs at  $-0.1$  milliampere, the output current at zero will be 20 milliamperes and a signal of  $+0.2$  milliampere will increase the output current from 20 to 90 milliamperes giving an increment of 70 milliamperes.

It will be observed that in Figure 9, for the purpose of determining and adjusting the bias current to the proper value, two resistors are shown, one included in the rectifier alternating-current connections, and one connected in the rectifier output circuit. The reason for this is as follows.

In a previous paper,<sup>5</sup> the author has referred to the phenomena that result when a rectifier is located in a circuit in which there may exist a double-frequency transformer voltage picked up in one saturating reactor direct-current winding due to the presence, in another direct-current winding, of saturating current containing a ripple component due to the fact that this current is supplied from another rectifier.

Because of the series or feedback winding in Figure 9, which is supplied by a full-wave rectifier, a double-frequency transformer electromo-

tive force is set up in the bias winding. This causes some rectified current to flow in the bias winding due to half-wave action of the bias rectifier, even though the alternating-current leads to the bias rectifier be opened.

For the purpose of adjusting the proper value of the current supplied to the bias winding from the alternating-current source through the normal full-wave action of the rectifier, only one resistor is actually necessary and this might be placed in either the alternating-current or the rectifier circuit. However, if the resistor is placed on the alternating-current side of the rectifier it is not included in the local circuit, which is involved when half-wave rectified current is set up in the bias winding due to the feedback winding ripple or double-frequency transformer voltage. On the other hand, if the bias-current-adjusting resistor is put in the output circuit of the rectifier, it substantially cuts down this "sneak" current to a value that is in most cases negligible. Since it is, in general, preferable to have some resistance in the alternating-current leads to the rectifier instead of connecting the latter directly to the alternating-current source, the total resistance necessary to furnish the desired current may be divided between the alternating-current and direct-current circuits, if desired, as shown in Figure 9.

It is to be noted that the amount of bias current required is roughly proportional to the amount of feedback. That is to say, increasing the number of series turns, or decreasing the output circuit resistance, will call for an increase in the bias current.

In the case of magnetic-amplifier applications in which the circuit constants are adjusted so as to obtain binary-stability characteristics as in

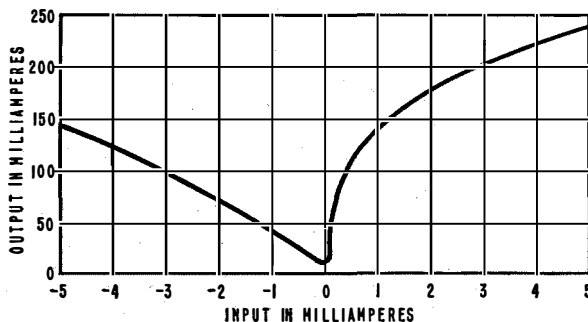

Figure 10—Response characteristic of amplifier with feedback and bias windings. The series winding is 200 turns.

<sup>5</sup> A. S. FitzGerald, "Some Notes on the Design of Magnetic Amplifiers," *Journal of The Franklin Institute*, v. 244, pp. 323-362; November, 1947: see page 349.



Figures 5, 6, and 7, the bias is also in most cases desirably included. For example, in each of these three curves, singular stability obtains at zero input. As has just been described in reference to Figure 10, by suitably adjusting the bias current,

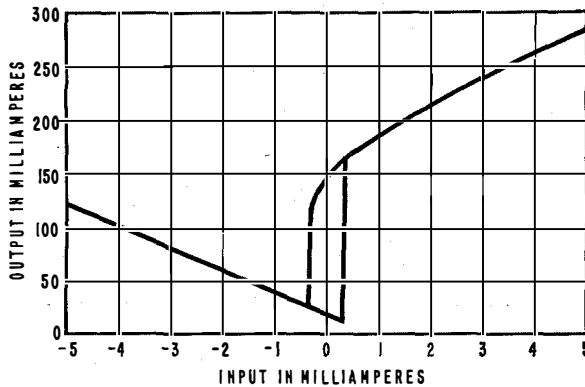

Figure 11—Response characteristic of amplifier with feedback and bias windings. The series winding is 350 turns.

the curve may be displaced laterally to any desired extent. Thus, by employing a suitable value of bias current, we can provide the characteristic shown in Figure 11, which refers to the amount of feedback used in Figure 7, which is 350 turns.

We now have the very interesting result of a circuit which, with zero signal, that is to say,

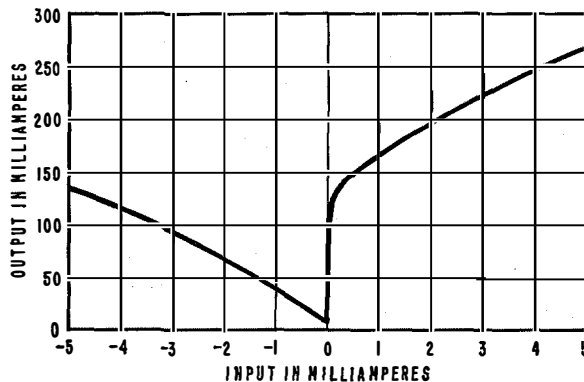

Figure 12—Response characteristic of amplifier with feedback and bias windings. The series winding is 300 turns.

with the input de-energized, has binary stability; it has two quite-different output current values either of which represents a completely stable condition that may be maintained indefinitely in the absence of a controlling signal.<sup>6</sup>

<sup>6</sup> FitzGerald, United States Patent 2,027,312.

In like manner, the use of the bias winding is desirable, for similar reasons, if the circuit is to be adjusted so as to furnish the floating control effect. Figure 12 shows the same characteristic as in Figure 8, with the bias adjusted so as to displace the whole curve slightly towards the right so that the critical floating action now takes place at zero input.

The manner in which the above three phases, or response characteristics, are manifested having now been very briefly outlined, we may now consider some of the ways in which these different action patterns may be utilized in magnetic-amplifier circuits. Each phase will be dealt with separately, and further and more detailed descriptive and explanatory data will be presented with particular reference to the several applications.

To restrict the volume of this text to reasonable dimensions, it will be necessary to limit the scope of this treatment mainly to qualitative description. Principles of design and details of structure and application are of necessity omitted at this time. In this connection, it should be stated that the figures given relating to numbers of turns of the series and alternating-current windings refer to one particular type of core and to a specific form of rectifier. They are cited for purposes of description and explanation and are not necessarily applicable to all types of circuit design.

## 2. Singular Stability

In a previous paper,<sup>4</sup> the author described the construction and performance of a group of magnetic amplifiers. In some of these units, feedback windings were incorporated for the purpose of studying the resulting increase in gain.

The above description represents a pertinent example of the use of feedback in magnetic amplifiers under conditions of singular stability. These data having been already placed on record, further mention thereof need not be made in the present text. For additional details, reference is invited to the above-cited publication.

However, the amplifiers described in the previous paper were intended for applications of the neutral type; that is to say, where either the response of the amplifier is independent of the polarity of the input signal or, alternatively, the polarity of the signal is not subject to reversal.

A very-brief consideration of the potential field of application of magnetic amplifiers is sufficient to indicate that, in a very large proportion of such possible uses of these devices, something more than a neutral or unilateral type of response is necessary.

Sensitive detecting and responsive devices such as amplifiers are most frequently needed in electrical control systems in connection with the well-known automatic self-balancing or null type of control principle. That is to say, systems that have a normal condition to which it is desired that they be automatically restored and that are subject to deviation in either of two directions from the normal; as for example, above or below correct temperature, voltage, frequency, or the like. Such systems require that some kind of restoring instrumentality such as might be driven, for example, by a reversing motor be operated selectively in the forward or reverse direction according to the sense of the deviation; and that the motor be stopped and remain at rest when the normal condition is restored. Two very-well-known examples of this principle are the

familiar potentiometer-type recorder and practically all servomechanism circuits.

Such systems essentially include either sensitive types of polarized relay, or electronic devices responsive to reversal of polarity or phase.<sup>7</sup>

It is clear, therefore, that such systems require a bilaterally responsive device; one that will respond selectively in accordance with the direction of deviation and that will also have a null or zero position to indicate that the condition is normal.

For example, if a polarized relay is used, it will have a central or normally open position when de-energized and will deflect in one or other of two directions, operating either of two contacts, according to the input polarity. Such types of polarized relay are usually referred to as giving three-position-type control.

The use of the feedback principle in magnetic amplifiers, under the condition of singular stability, may be utilized so as to realize a magnetic amplifier having a polarized response action of the three-position type analogous to that of a polarized relay. These polarized types of magnetic amplifier are capable of extremely high sensitivity, considerably surpassing the performance in this respect of the neutral-type amplifiers described in the above-cited previous paper.

**3. Push-Pull-Type Polarized Amplifiers**

By the use of saturating reactors with feedback windings in pairs, results closely approximating the type of action of a three-position polarized relay are possible.

Figure 13 shows a typical arrangement.<sup>2</sup> Two saturating reactors, complete with feedback and

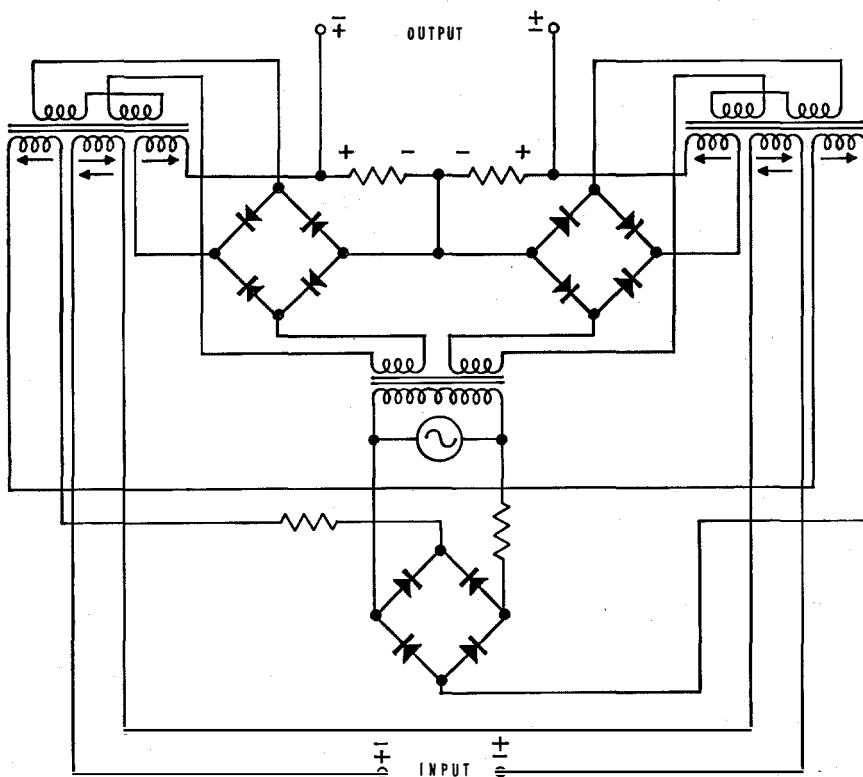

Figure 13—Push-pull polarized-type magnetic amplifier.

<sup>7</sup> FitzGerald, United States Patent 1,931,069.

bias windings in accordance with Figure 9, have their outputs connected to two resistors, both having the same resistance value. The two resistors are joined together at the negative extremities. To make this connection possible, both reactors must be supplied from separate alternating-current sources. An isolating transformer having two secondary windings is therefore furnished for this purpose. Both bias windings are connected in series and supplied by a single, separate, rectifier.

The two input windings are connected in series in opposite sense; that is to say, if the magnetomotive force due to one of the input windings is additive with respect to the magnetomotive force of the series winding, the magnetomotive forces of the input and series windings on the second reactor are in opposition. Each bias winding is connected so that it opposes the series winding.

It will be apparent on inspection of this diagram that if the outputs of both of the two reactors are exactly equal there will be no voltage difference between the ends of the two resistors.

Two terminals are accordingly connected thereto and the output of the amplifier is withdrawn at these terminals. Thus, if we connect a load circuit in series with a central-zero-type milliammeter to the output terminals, when there is no input, the currents in the two resistors are equal and no voltage difference appears at the output terminals. The output meter therefore indicates zero.

If, now, we apply a small current to the input circuit, one of the amplifier elements will receive a positive signal and the other will receive a negative signal. If we refer to Figure 4, it is apparent

that this will have the result of increasing the current in one of the resistors and decreasing that in the other resistor and the output meter will now show a deflection.

If the right-hand input terminal be made positive with reference to the left-hand terminal, the current delivered by the right-hand amplifier element will be increased and that of the left-hand unit will be decreased. Accordingly, the right-hand output terminal will become positive in respect of the left-hand output terminal.

If the direction of the input excitation be reversed, the polarity of the output will likewise reverse.

It will be noted that the function of the two resistors in Figure 13 is analogous to that of the coupling resistors in a push-pull-type electronic amplifier.

As shown in Figure 13, the two bias windings are supplied in series with a current-limiting resistor, from a rectifier, which is energized in series with a second resistor from the alternating-current source. A gain-control effect can be obtained by adjusting the value of the current that

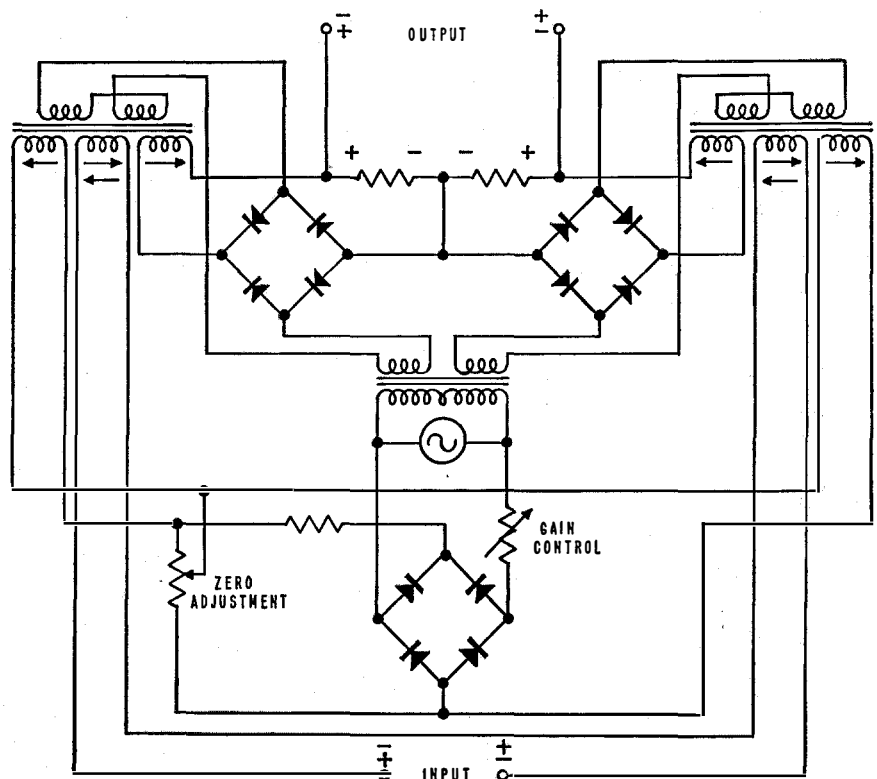

Figure 14—Polarized magnetic amplifier with gain control and zero adjustment.

flows in both bias windings. On referring to Figure 4, it will be noted that the slope of the output-current curve has a maximum value a little to the left of the input zero axis. The gain will be a maximum when the bias current is adjusted so that the two amplifiers are operating on that portion of the curve.

The purpose of Figure 13 is to present the general principles of this type of magnetic amplifier in a direct and simple manner. Thus, only the essential functional elements are shown in Figure 13. Figure 14 shows a complete diagram of such an amplifier including in addition to the gain control a zero-adjustment feature as well.

The zero adjustment is to permit of accurate balancing of the pair of magnetic-amplifier circuits so as to compensate for any inequality of structural components such as resistors, rectifiers, etc. In Figure 14, a potentiometer-type adjustable resistor is connected in parallel with the two series-connected bias windings. That is to say, the sliding contact of the potentiometer is connected to the common point of the two windings; the two ends of the potentiometer resistance element are connected to the two other extremities of the bias windings.

Thus the two sections of the potentiometer resistance form two shunts that, when the potentiometer is in midposition, divert equal amounts of current from each bias winding. When the potentiometer is operated in one direction or the other, the current in one bias winding is very slightly increased while that in the other is, at the same time, decreased. This has the effect of displacing the output current curve of Figure 4 in opposite sense in respect to each of the two magnetic-amplifier elements. This increases the current in one coupling resistor and decreases that in the other, thereby deflecting the pointer of the output instrument to the right or to the left according to the direction in which the knob of the potentiometer be turned.

In this way, the output meter, when there is no input to the amplifier, can be set exactly to zero by turning the zero-adjustment control in the proper direction as may be needed.

Only a single stage is illustrated in Figures 13 and 14. However, the arrangement of the circuit is such that any number of separate stages may be directly connected in catenation. For example, if a single stage of a polarized amplifier such as that of Figure 14 be schematically indicated in block diagram form, the power-supply, input, and output terminals being positioned in a corresponding manner and turned through 90 degrees, a three-

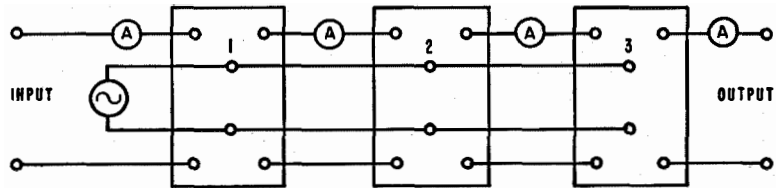

Figure 15—Three-stage polarized magnetic amplifier.

stage magnetic amplifier layout would appear as shown in Figure 15.

It will be noted that, when a number of stages are employed, central-zero-type meters can be included in each interstage connection as well as in the main input and output circuits as shown in Figure 15. Thus, each individual stage can be checked for zero setting and its functioning studied and supervised. The meters may all be connected with uniform polarity so that they will all deflect in the same direction in accordance with polarity of the signal.

It is of interest to note in this connection that the proper bias adjustment should always be such that the individual pairs of amplifier elements, with zero signal, are operating on that portion of the curve of Figure 4 that lies to the right of the nadir. If by inadvertence the bias be adjusted so that the units become operative in the left-hand zone of the output curve, the stage so maladjusted will cross over or reverse; that is to say, if, for example, the input meter shows a deflection to the right, the output meter will deflect in the reverse direction.

Push-pull-type polarized magnetic amplifiers of an order of sensitivity comparable with that of the neutral-type amplifiers previously referred to are no more complicated or critical in use or adjustment than the latter.

However, the balanced type of circuit permits the use of feedback to a much more substantial

extent than is possible in the simpler type of circuit. Amplifiers of the polarized type have been constructed that will respond to power levels in the range of from  $-60$  to  $-90$  volume units; that is to say, between  $10^{-9}$  and  $10^{-12}$  watts.

In the development of magnetic amplifiers operating in this low input range, problems are encountered that are not met with to any appreciable extent when working with the higher signal levels previously discussed.

The most important problems in the design and application of high-sensitivity polarized amplifiers arise in connection with the ratio between the normal response level and the maximum signal intensity to which the amplifier can, under any possible condition, be subjected. This question is important for two reasons.

In the first place, the basic circuit principle of the push-pull-type polarized amplifier is such that this arrangement is essentially limited to a finite range of signal levels.

If we consider the action of the circuit of Figure 13 in reference to the curve of Figure 4, it is evident that the output of this circuit is proportional to the difference between the individual output currents of the pair of amplifier elements resulting from positive and negative signals of equal value.

A study of the curve of Figure 4 indicates that at first this difference increases with increase of signal level. With further increase in the signal, the difference ceases to increase, and with very high signal levels the difference commences to decrease. Clearly this type of circuit will be functional only so long as this difference is manifested. It is of interest to note, however, that despite the above considerations this type of circuit is operative with signal power levels up to several hundred thousand times the minimum response level.

The second reason, which involves consideration of maximum possible signal levels, is not associated with the nature of the circuit structure but results from the increased sensitivity that is possible with amplifiers of this type.

Subjection of magnetic amplifiers to signal levels of high intensity results in hysteresis effects. These effects necessarily become apparent in proportion as the sensitivity is increased. That is to say, the lower the signal level the greater will

be the relative magnitude of any given hysteresis effect.

The extent of this effect is quite appreciable in high-sensitivity polarized amplifiers. For example, in a typical instance in which the amplifier had a minimum response level of 50 microvolts, when the amplifier was subjected to a signal of a thousand times this voltage, that is to say, one million times the minimum signal power level, a zero shift resulted which exceeded several times the threshold value.

Such a zero shift can readily be erased, and the original zero position restored, merely by subjecting the amplifier to a signal of suitable intensity of the opposite polarity.

However, in practical applications of magnetic amplifiers it is necessary or very desirable that this difficulty be taken care of automatically.

It has been pointed out above that it is especially in connection with automatic control systems of the self-balancing or follow-up type that polarized amplifiers appear to have particular pertinence. It is, therefore, important to remember that it is an unavoidable condition in such systems that under certain abnormal operating contingencies the amplifiers may be energized with signal intensities greatly exceeding the regular or normal follow-up increment or error-signal level. Such a condition may occur, for example, when a control system is initially connected to the supply source, or is energized subsequent to a power-supply interruption, under which circumstances it can happen that the follow-up system may be in a condition of maximum displacement from the null or normally balanced position.

Considerable study has been given by the author to the problems arising from these circumstances and various arrangements have been adapted or devised by means of which these abnormal signal magnitudes may be bypassed or limited, or in some way prevented from adversely affecting the operation of the amplifier.

The use of the nonlinear characteristics of dry-disk-type rectifying films, connected in parallel pairs in opposite sense so as to give bilateral conductivity, as a bypass device or limiter is well known. However, in the case of selenium films there is no substantial conductivity at voltages substantially less than one

volt and in the copper-oxide film some hundreds of millivolts.

In magnetic-amplifier circuits, for any given power level, the signal voltage, and therefore the applicability of a simple limiter, will depend upon the input circuit resistance. In general, it may be said that with magnetic amplifiers of any substantial degree of sensitivity, the signal voltage seldom approaches a magnitude at which a simple copper-oxide limiter manifests any conductivity.

The use of negative feedback<sup>2</sup> is an effective means for excluding from the input winding currents high enough to cause hysteresis zero shift. It also improves the speed of response. There is, however, a substantial resultant loss of gain.

One arrangement<sup>2</sup> devised by the author and which may be described as a "blocking-limiter" is shown in Figure 16.

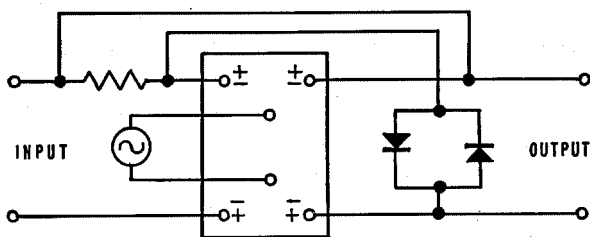

Figure 16—Blocking-limiter.

The blocking-limiter circuit consists of a resistor connected in series with the input circuit. This resistor is also connected across the output of the polarized amplifier in series with a bilaterally conducting nonlinear film element such as, for example, two copper-oxide films connected oppositely in parallel.

The number of films in series is so selected, in relation to the output voltage, that no substantial conductivity occurs when the amplifier receives signals not greatly exceeding the normal working magnitude. When, however, the signal level under abnormal conditions becomes very greatly increased—for example, if it is 100 or more times its minimum response level—the output voltage, being commensurately increased, reaches the order of magnitude at which the limiter passes current. The polarities of the connections to the resistor are made such that, as shown in Figure 16, the voltage drop set up

thereby across the resistor is in opposition to the signal voltage.

Accordingly, the action of this arrangement is to block signals of abnormal magnitude. Under such conditions, the current in the input winding is limited to values of moderate magnitude such that no substantial difficulty in connection with hysteresis effects is involved.

On the other hand, the blocking-limiter is entirely inert under normal signal conditions and in no way vitiates the sensitivity of the amplifier.

Only a single stage is indicated in Figure 16. However, the blocking-limiter is particularly effective when it is energized from the output of a second stage.

The blocking-limiter, however, is only effective when the circuit is energized and does not give protection if the amplifier can receive an over-voltage signal of a magnitude likely to cause hysteresis difficulties when it is de-energized as, for example, due to system power interruption.

In many instances, however, the signal itself may emanate from a device likewise electrically energized from the same power source in which case no such signals can arise under this condition.

For reasons of space, further and more detailed description of these methods cannot be given here. However, to indicate the extent of the progress that has been made in the solution of this problem, it may be stated that amplifiers of the polarized type have been constructed capable of responding properly to a signal of  $20 \times 10^{-12}$  watts following the application of a strong signal 60,000 times greater than this value.

In concluding this discussion of the use of feedback under conditions of singular stability, it may be pointed out that it is not possible to present any definite figures as to the amount of increase in output or gain that can thereby be attained.

The reason for this is that as the gain is increased by appropriately adjusting the circuit constants to this end (it has been pointed out above that increasing the feedback does not necessarily cause an increase in the gain), a condition is in due course reached in which each increment in the circuit adjustment results in greater and greater increase in gain accompanied by commensurate impairment in the stability; that is to say, in the ability of the amplifier to

“reset” or be restored to the previously prevailing condition, following withdrawal of the signal.

In the absence of any definition as to acceptable or unsatisfactory stability characteristics, it is impossible to say just how much increase in

Figure 17—Electromechanical analogue of application of binary stability.

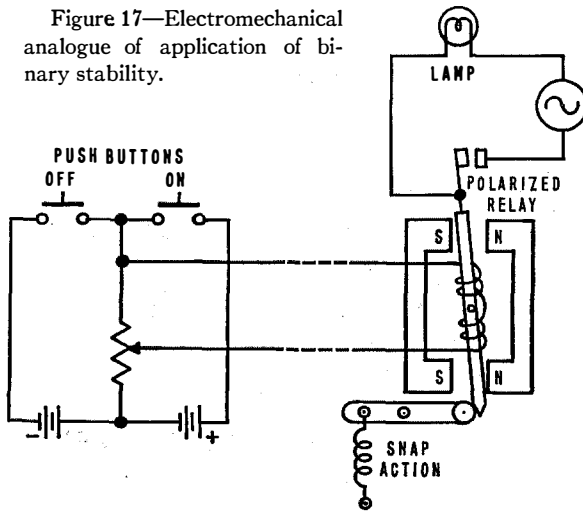

gain resulting from the use of feedback can be achieved. This will depend upon the conditions obtaining in individual applications and will be mainly determined by maximum-signal exigencies of the nature discussed immediately above.

In other words, there is no line of demarcation between the action of Figure 4 and of Figure 8. Between these two conditions, there is a penumbral zone characterized by a marked increase in gain and dynamic response characteristics of doubtful acceptability.

**4. Binary Stability**

The arrangement of Figure 9, when the circuit constants are adjusted so as to give the characteristics of Figure 11, is capable of manifesting a most interesting type of action, similar to that of the familiar “latched-in” type of electric relay.

This effect may, perhaps, be more easily described and explained by referring to Figure 17, which shows an exact electromechanical analogue of the action that is possible with a saturating-reactor circuit under conditions of binary stability.

In Figure 17, a load or indicating device, such as a lamp, is controlled by a polarized relay that has a snap-action spring control arrangement so that the armature cannot remain in midposition but snaps one way or the other according to the polarity of the direct current applied to the coil, and always remains in the position of the last operation when the control current is withdrawn. The relay is controlled over a two-wire circuit by means of two push buttons and a midtapped battery, so that the coil of the polarized relay may be energized at will with a signal of either polarity. Obviously, pushing one button momentarily will cause the lamp to light and to stay lit. Operating the other button will put the lamp out, which condition will be retained until the ON button be again actuated.

At first thought, it would almost seem that a physical movement or a change of position of some material member is a functional necessity inherent in such a system.

However, exactly similar action is manifested by the arrangement shown in Figure 18, in which the lamp is energized from the circuit of Figure 9,

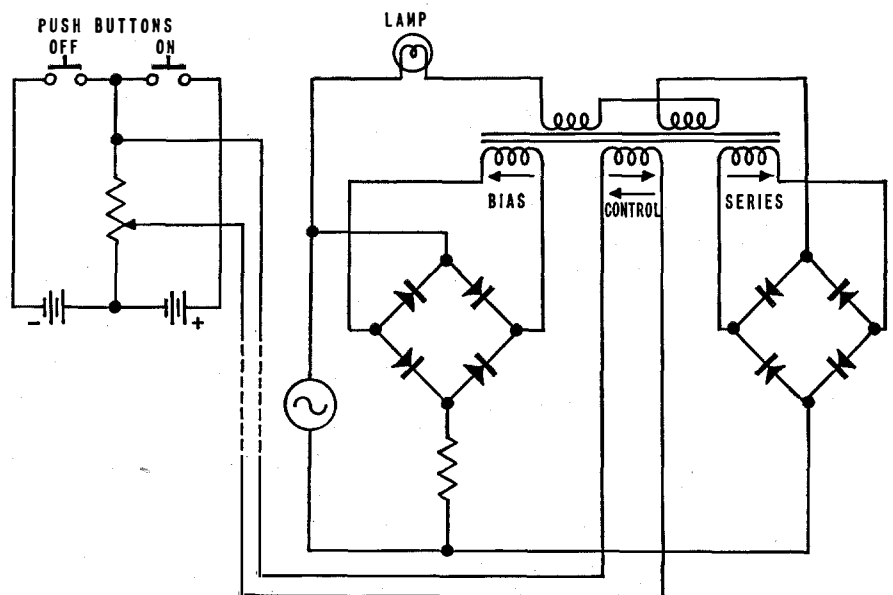

Figure 18—Application of binary-stability principle to control circuit.

the input coil of which is energized by the same battery and push-button arrangement as in Figure 17. There are no moving parts in this system and all the circuits are permanently closed with the obvious exception of the signal-emitting device, duplicating that of Figure 17.

If the circuit is adjusted in accordance with Figure 11, when the ON button is depressed the lamp lights. When the button is released the lamp remains illuminated. If the OFF button be now operated, despite the fact that the magnetic-amplifier circuit remains connected to the power supply, the lamp will appear to go out; that is to say the current will be reduced to a low level insufficient to cause the lamp to emit any visible light. After the OFF button is released the lamp remains out.

It is believed that it will be apparent to the reader that this action logically results from the characteristic illustrated by the curve in Figure 11 and that further explanation will be unnecessary.

The analogy between this magnetic-amplifier circuit and the electromechanical arrangement of Figure 17 is maintained under another operating condition in an even-more-striking manner. If the alternating-current supply to the magnetic-amplifier circuit in Figure 18 be interrupted, when the power is restored, neither push button having been operated in the meanwhile, the action existing at the moment of disconnection will be reproduced. If the lamp was not illuminated when the power was withdrawn, it will not light up when it is restored. But if the light was on when the power was disconnected, as soon as the circuit is again energized, the lamp lights up again.

Furthermore, if the signal be applied at a time when the magnetic amplifier circuit is de-energized, whether or not the lamp will light when the alternating-current power is restored, can be predetermined.

This "memory" action is due to a residual-magnetism effect in the core.

The application of an input signal of reversible polarity is not, however, the only effect by means of which the binary-stability circuit may be caused to transfer from one range to the other and therefore to undergo a change in current value of substantial amplitude. A study of the curves of Figures 5, 6, 7, and 11 will indicate that there are

a number of different changes in circuit constants that can cause such a transfer.

For example, if we refer to Figures 5, 6, and 7 it is apparent that a modification in the amount of feedback such as might cause the circuit char-

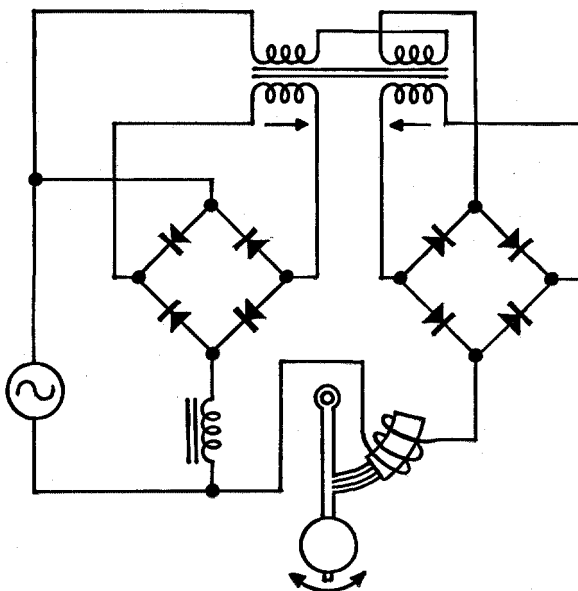

Figure 19—Binary-stability principle used for pendulum drive.

acteristics to change from, say, Figure 5 to Figure 7 can cause this transfer. This may be seen to be the case, for instance, at the portion of the curves corresponding to an input excitation in the neighborhood of  $-1$  milliamperes. Such a result could occur if the feedback turns be changed from 450 to 350.

However, it has been pointed out that the feedback is a function of the output circuit resistance as well as the turns. The same result might take place if instead of changing the feedback turns, the resistance or impedance of the load circuit be modified.

Figure 19 shows an intriguing application of this principle. A pendulum is provided with an actuating solenoid having a suitably shaped plunger mounted on the pendulum and entering and retracting from the solenoid coil as the pendulum swings.

The reactance of this solenoid winding will, of course, vary as the plunger enters to a greater or less extent into the coil. When the plunger swings fully into the coil, the reactance will be relatively



high; when it swings in the other direction, a lower value of reactance will result.

In Figure 19, the solenoid winding is energized from a binary-stability-type circuit such as has been described. It is clear that an increase in the

and accordingly the pull exerted thereby on the plunger, which pulsates in synchronism with the swing of the pendulum, has the characteristics necessary to drive the pendulum. Thus, once the pendulum is started, swinging motion is

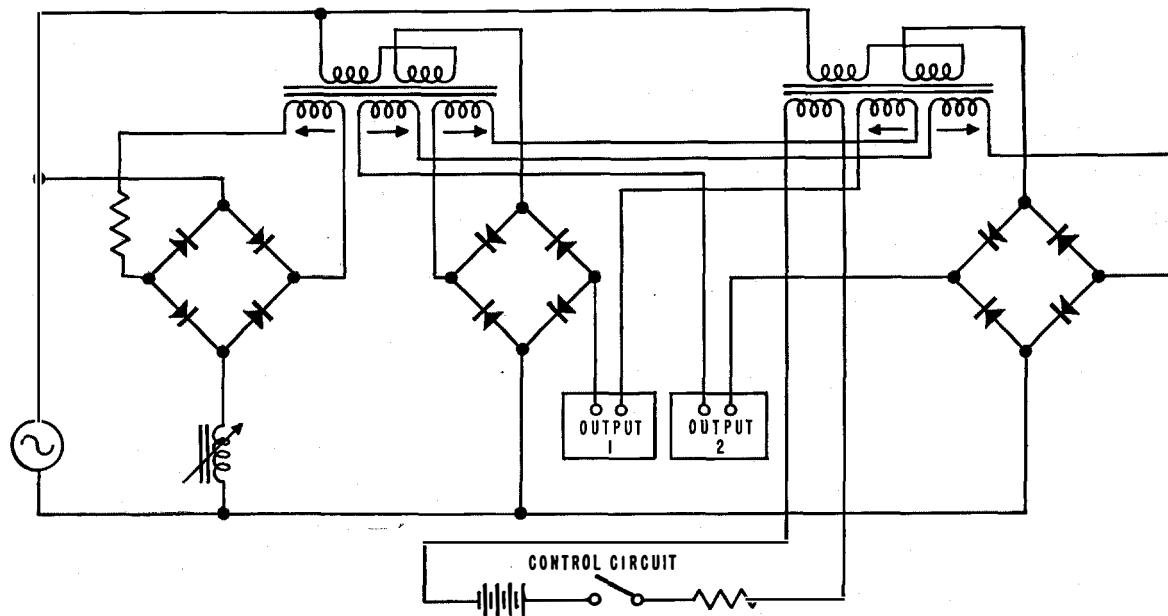

Figure 20—Oscillating or pulsating magnetic amplifier circuit.

reactance will reduce the effective feedback; and that, conversely, the feedback will be greater when the impedance is less. It follows therefore that the feedback will decrease when the plunger swings fully into the coil and will become greater when it swings in the outward direction.

Clearly, if this merely caused a more or less proportional variation in the current in the coil, no effective dynamic action could result. However, in the arrangement of Figure 19 the circuit constants can be adjusted so that the movement of the pendulum results in the discontinuity effect whereby the circuit transfers from one stability range to the other, and back again; this causes not a gradual, but an abrupt and substantial, change in current due to the plunger movement. That is to say, at a certain point on the outward travel of the plunger the current suddenly increases several hundred percent; in like manner as the pendulum swings towards the coil a sudden change in current in opposite sense takes place.

It is clear that this relation between the plunger position and the current in the solenoid,

continued as long as the circuit is energized with alternating current.

While it is not obvious that this device has any great value in horology, nevertheless it forms a very simple and inexpensive action device for display or other purposes where an oscillating movement may be of interest. The absence of any contacts should be favorable to reliability.

It is also of possible interest as a generator of pulsating electrical effects of more substantial magnitude since, by further stages of magnetic amplification, the pulsating current in the circuit of Figure 19 may be stepped up to substantial power levels. For example, instead of the pendulum, an oscillating system based on spring instead of gravity control may be used to provide an electric hammer or riveter.

It is, however, by means of this binary-stability-circuit principle, possible to produce a sustained pulsating effect without any mechanical moving element. If a pair of circuits of the form shown in Figure 9 be connected together so that

each one acts as a teaser for the other, it is possible to arrange for mutual interaction such that the dual circuit continues indefinitely in a condition of oscillation or pulsation.

Such an arrangement<sup>8</sup> is illustrated in Figure 20. In this diagram, it will be noted that the output circuit of each of the duplicate magnetic-amplifier elements is connected in series with the input circuit of the other one. Thus when the right-hand unit transfers from the lower range of stability to the upper range it delivers a signal to the left-hand unit such as to cause this likewise to change from the low value to the high current value. This in turn energizes the input of the right-hand unit in the opposite sense, throwing the latter back into the lower stability

<sup>8</sup> FitzGerald, United States Patent 2,168,402.

range. This closed-cycle chain reaction continues as long as the circuits are energized from the alternating-current source. Special features may be included in the bias circuits for inhibiting the pulsating effect or for permitting it to occur. Other circuit adjustments may be included that have the effect of modifying in some degree the type of dynamic action that ensues. For further details of these arrangements reference is invited to the citation.

An application of this latter principle is illustrated<sup>8</sup> in Figure 21. In this arrangement, one of the output currents of the system shown in Figure 20 is connected in series with the input windings of a pair of single magnetic-amplifier stages of the compensating-winding type shown in a previous paper.<sup>3</sup>

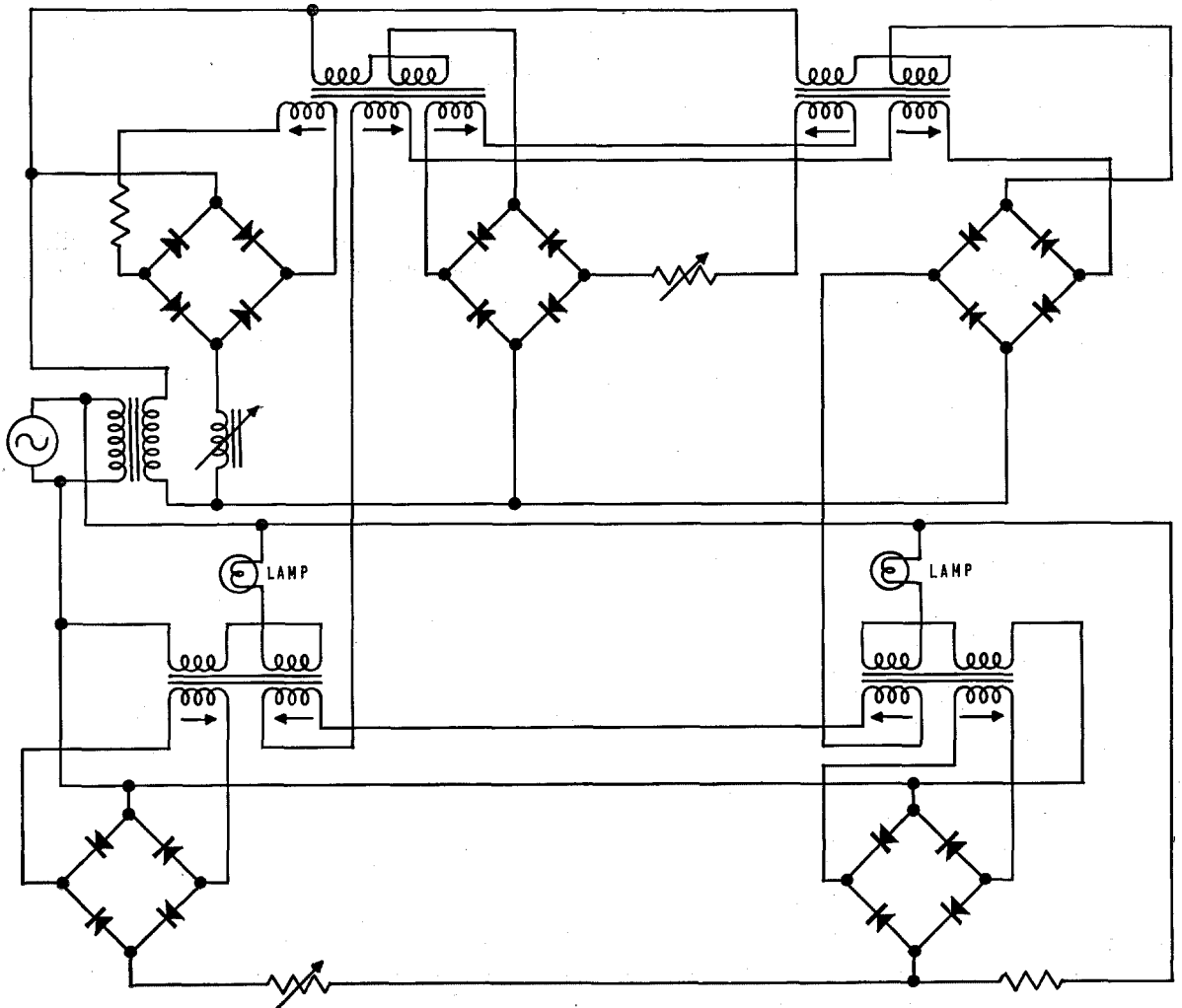

Figure 21—Lamp-control application of pulsating circuit.

Each of the output circuits of both of these magnetic amplifiers is connected to a signal lamp.

The input windings of the pair of amplifiers therefore both receive identical signals consisting of a unidirectional current continuously pulsating between a high and a low value. Both of the lamp amplifiers are identical except that the compensating currents are not adjusted to like values. In one case, the compensating excitation is adjusted to be equal to the input signal when the current is at its minimum value; in the other case, the bucking ampere-turns are made equal to the maximum value. Thus one of the lamp amplifiers will deliver only a very-low current when the signal has its minimum value and the lamp will be lighted when the input current has its high value. The other lamp, however, will be out with the high value of the pulsating current and on when it has the minimum value.

Thus the two lamps will flash alternately in the manner of the familiar grade-crossing danger signal. This complete arrangement, it will again be noted, has the reliability feature of complete absence of contacts or moving parts.

### 5. Modulating Condition

This phase of the behavior of feedback-type magnetic amplifiers is probably of the greatest potential value in that it makes possible amplifiers having very accurate linear response characteristics.

We shall now consider more specially the action of the circuit of Figure 9 when the circuit constants are chosen so as to provide the response characteristics of the type shown in Figure 12.

Figure 22 shows the circuit of Figure 9 with the addition of an output circuit that includes a milliammeter and an adjustable series resistance, together with a push-button arrangement similar to that of Figure 18 for furnishing an input of re-

versible polarity. A second adjustable resistor is provided for determining the value of the bias current.

Assuming that the type of rectifier and the number of series or feedback turns are suitably chosen and that the resistance of the load or output circuit is somewhat less than the optimum value, the action of the circuit can be controlled by the two adjustable elements, the bias resistor and the series resistor. The latter serves as a trimmer; it may be of a low value as compared with that of the output circuit, and such as enables the sum of the trimmer and the output circuit resistance values to be varied somewhat above and below the estimated optimum output circuit resistance.

To secure the desired characteristics, these two controls are to be adjusted with some nicety. The exact values that are required are determined by observing the behavior of the pointer of the milliammeter. As described above, when the adjustments have been correctly made this instrument gives an indication of indeterminate value; that is to say, it behaves like a fluxmeter or other uncontrolled type of instrument.

It will be recalled that the floating condition that is desired, and which is illustrated by the curve in Figure 12, lies between the singular-

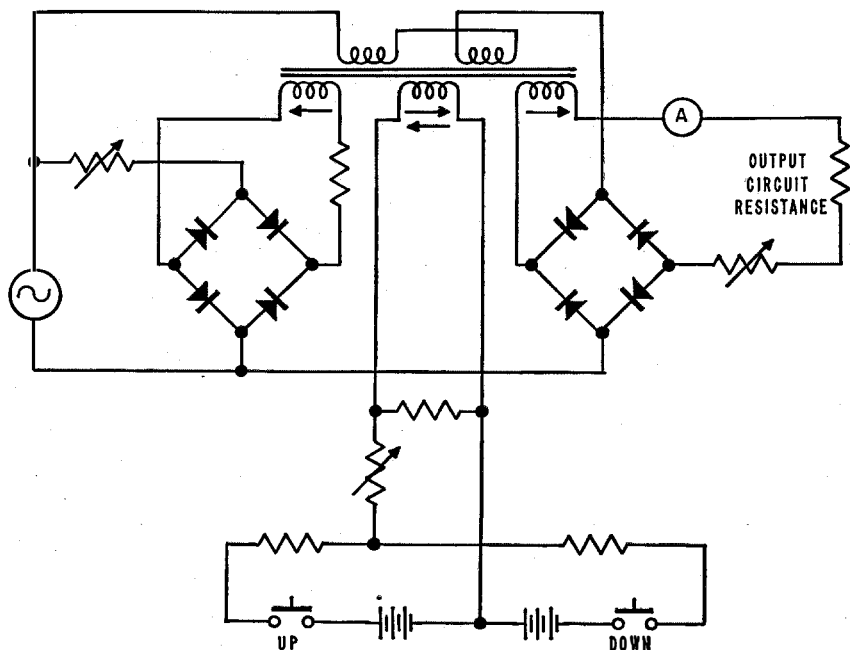

Figure 22—Modulating circuit.

stability characteristic of Figure 10 and the binary type of response of Figure 11. Clearly, if the adjustment departs from the optimum in one direction, the action will tend towards singular stability, and if the adjustment deviates in the opposite sense, there will be an approach to the binary condition of stability.

In each case, the behavior of the instrument pointer will be characteristic of the sense of deviation.

It is believed that a description of the relation between the circuit adjustment and the action of the instrument pointer may possibly be somewhat simplified by consideration of the visual aid or analogue shown in Figure 23. The action of the meter pointer, in response to a slowly varying signal, may be compared with that of a circular object rolling on an approximately horizontal curved surface.

As suggested by the diagram, the roller rests on the upper surface of a containing member capable of being tilted in either direction. Nine concepts of this structure are illustrated. It is shown as having a concave, flat, or convex surface. It is also shown in three different positions: tilted to the left, horizontal, and tilted to the right.

There is a close analogy between the manner in which the pointer of the milliammeter responds to a signal applied to the input of the amplifier and the way in which the roller will behave if a force be applied to it laterally, tending to displace it to the right or to the left. Similarly, adjustment of the bias current in the electrical circuit corresponds closely with the effect of a tilt in the mechanical counterpart shown in Figure 23.

For example, suppose we first consider the case of a concave surface. If there be no tilt and in the absence of any controlling force brought to bear on the roller, the latter will take up a position at the lowest point of the curve, approximately at the center. If, by the application of an external

	TOO MUCH BIAS	CORRECT BIAS	TOO LITTLE BIAS	
TOO MUCH RESISTANCE				SINGULAR STABILITY
CORRECT RESISTANCE				MODULATING CONDITION
TOO LITTLE RESISTANCE				BINARY STABILITY

Figure 23—Mechanical analogue of action of modulating circuit.

force, it be displaced from this position it will return there when the force is withdrawn. This is clearly a case of singular stability and corresponds with the action of the electrical circuit when this is adjusted in like manner, that is to say, when the circuit constants are such as to produce a tendency towards the characteristics of Figure 10.

In Figure 22, the push button that emits the positive signal is marked UP and the other one DOWN. The explanation of the action that follows refers specifically to very-weak signals, under which condition the phenomena to be described are manifested. Accordingly, a low resistance is connected in parallel with the input winding for the dual purpose of precluding opening of the input circuit by the push buttons and to limit the current in the input winding to a very-low order of magnitude. A variable series resistance of relatively high value permits the signal level to be controlled with convenience and precision at the desired low values.

In the absence of any signal, the bias is adjusted so that the meter reads at midscale. If now the UP button be operated so that a positive signal of a low value be delivered to the input of the amplifier, the meter pointer will be deflected to the right. When the button is released the pointer will return to its previous position at midscale. Exactly similar action in the opposite sense will result from the operation of the DOWN button.

If the bias current be increased, the meter pointer will have a normal position somewhat to the left of or below midscale. Similarly, if in the

mechanical analogue the surface be tilted to the left the normal position of the roller will likewise be more to the left. Decreasing the bias current gives an increased reading on the meter in the same way that tilting the surface to the right displaces the roller to the right.

Let us now consider the action when the surface is convex. In this case it will not be possible to retain the roller in the center of the surface without the application of an external force. It will tend to remain either at one or the other end of the convex surface. If by applying an external force it be removed from either extremity, when the force is withdrawn it will, if the surface is not tilted, roll towards whichever of the two ends it is nearer.

In the same manner, if the electric circuit be adjusted such that the binary-stability condition obtains, the pointer of the instrument will not remain in midscale. It will take up a position towards the high or low end of the scale, and it will only be possible to transfer it from one position to the other by means of an input signal of sufficient magnitude of either positive or negative polarity as may be required.

If the bias current be increased, it will require a stronger positive signal to move the pointer from the low to the high position; but a signal of reduced strength will be sufficient to transfer it in the downward direction. This corresponds with a tilt to the left. Reducing the bias has the opposite effect corresponding to a tilt to the right; that is to say, it will be easier to move the pointer in the upward direction than downward.

If now the circuit constants be adjusted to an intermediate condition so that the desired "floating" action is approached, the instrument pointer will behave in the following manner. If we operate the UP button and apply a fairly strong positive signal, the instrument pointer will move towards the right, indicating an output current value in the upper portion of the scale. If we then release the push button the pointer will be seen to remain in the vicinity of the latter position for a substantial period of time. Ultimately, it may tend very slowly to drift away from this position.

If on the other hand, we apply a negative signal by operating the DOWN push button the pointer will be deflected towards the left and will take up a position indicating a low current

value. And again, when the push button is released the pointer will remain for a substantial time at or near that position.

In like manner, if the pointer be positioned in midscale as may be done by suitably operating the push buttons, it will retain this approximate position when the positioning signals are withdrawn.

Suppose now we apply a very-weak signal. If this signal be of positive polarity, the milliammeter pointer will be observed slowly to move towards the right, that is to say, in the direction of increasing output current. If the push button be operated intermittently the pointer may be "inched" or "jogged" upwards. So long as the push button is depressed, the pointer will move to the right. When the push button is released, the movement will stop. Exactly the same action will be noted in the opposite direction if the other push button be operated so as to apply a weak negative signal.

Under these conditions, the action of the circuit will correspond to the condition suggested in the mechanical analogy when the surface is approximately both flat and horizontal. If the roller be displaced in either direction, there is no strong restoring force tending to return it to the central position, as when the surface is concave; or tending to cause it to move either to the right- or left-hand extremity, as is the case when the surface is convex.

Continuing to consider the mechanical analogy, it will be evident that the force necessary to displace or position the roller when the surface is flat and horizontal, will be very much less than that which is required when the surface is curved or inclined.

Correspondingly, therefore, when the electrical circuit is adjusted so as to give the "floating" action, and has exactly the proper amount of bias, the pointer may be displaced or positioned by means of a signal of much-weaker value than is necessary with either a singular or binary condition of stability. That is to say, the value of the output current can be controlled or modulated with transient input excitation of a very low order of magnitude.

As has been mentioned above, the optimum adjustment is arrived at by observation of the behavior of the instrument pointer. This procedure may be described with some gain in con-

ciseness if we may refer to the action of the electrical circuit in terms based on the mechanical analogue. Thus the correct adjustment of the bias current determines the degree of "levelness." This is indicated by the rate of movement of the instrument pointer up or down when signals of the same magnitude but of positive and negative polarity are alternately applied. If the reading of the milliammeter goes up in response to a positive signal more rapidly than it is reduced by a negative signal, the bias should be increased. Conversely, if the pointer moves with greater speed towards the left with a negative signal but more slowly towards the right of the scale with a positive signal of the same magnitude, then the bias should be decreased.

The "flatness" of the characteristic is indicated in the first place, in making the preliminary adjustment, by whether the pointer tends to drift towards midscale, indicating singular stability, or whether it tends to drift to either the left extremity or to the right extremity of the scale, which signifies that the circuit adjustments are such as to cause binary stability, in the absence of any signal.

When action indicative of strongly marked "concave" or "convex" characteristic has been eliminated by adjustment of the trimmer or series resistance, indication of the degree of flatness may be deduced by noting the speed of movement of the pointer at different portions of the scale, in response to weak signals.

Thus, if the pointer is indicating a low current value towards the left-hand end of the scale and a positive signal be applied, the pointer will commence to move towards the right. If with no change in the signal the rate of movement of the pointer increases, this will be an indication that there is still some "convexity" present. If, on the other hand, the rate of movement of the pointer decreases, and if, perhaps, the pointer comes to rest without reaching the upper portion of the scale, it may be inferred that some degree of "concavity" is still present.

In other words, the objective that is aimed at in making this adjustment is that the application of weak signals of the same value of both positive and negative polarity should, in the first place, approach a speed of response that is equal in both directions; and in the second place, this

speed of response should be substantially the same at all points on the scale of the instrument.

An electromechanical counterpart of the above circuit would be represented by a variable-output device such as a rheostat, driven by a reversing motor controlled by the two UP and DOWN push buttons. With such an arrangement, the output current will be determined by the position of the rheostat arm, which latter will move in one direction or the other as the motor is operated. Thus the output current will increase steadily as long as the UP push button is held down, or will continue to be reduced as long as the DOWN button is operated, and will remain at a constant value when neither of the push buttons is depressed.

The practical utility of this modulating circuit is not predicated on the achievement of absolute perfection in the reproduction of the action of the above electromechanical counterpart. That is to say, it is not essential that the output current remain at a constant value, when there is no signal, for an indefinitely prolonged period of time. In self-balancing regulating or control systems of the type to which reference has been made above, it is of equal significance if the current value be held for moderate periods of time of the order of a minute or two. In such systems, whenever there is a deviation from the proper value to which the current should be modulated, a corrective signal is automatically set up so that the required value is continuously maintained. Indeed, in many such control arrangements the output current is not required to be regulated to a constant value but rather one subject to continuous or frequent variation. In such circumstances a perfect type of action capable of holding a current at a fixed value for long periods of time would have no pertinence.

## 6. *Linear-Response Amplifier*

This modulating principle may be utilized to provide a self-regulating type of magnetic amplifier capable of giving an accurate linear response to an input signal.

Such an arrangement is shown in Figure 24, in which the output current is continuously automatically regulated so that it bears a constant relation to the input signal. This ratio is

maintained by means of a tapped resistor or potential divider, which is energized from the output of the amplifier. A given fraction of the output voltage obtained from the tap on the potential divider is compared with the signal, and any

to zero when there is no signal, is of the counterpoise type, which has already been described<sup>9</sup> by the author elsewhere.

It has already been mentioned that, as is seen in Figure 12, the range of the modulator-type

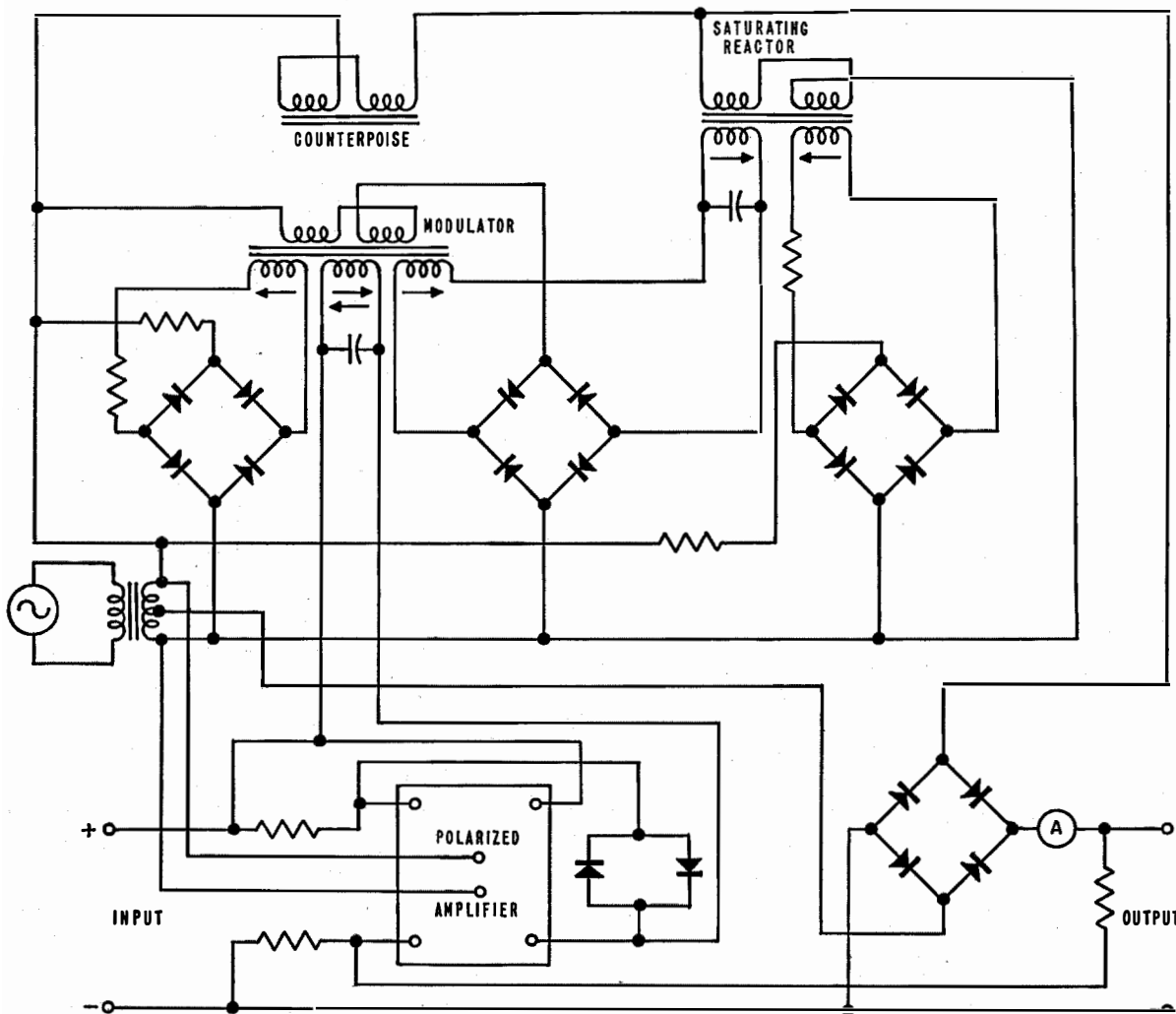

Figure 24—Linear-response magnetic amplifier.

difference between these two voltages is amplified by a polarized-type amplifier and applied as a control signal to a modulator-type circuit such as that in Figure 22. Thus, the output of the modulator is increased if the voltage obtained from the potential-divider tap is less than the signal voltage, or is decreased if the output is greater than the proper value.

The output of the modulator is fed to a third stage, which is of the neutral type and which, because it is required that the output be reduced

circuit does not go completely down to zero. For this reason, the third stage is provided with a compensating winding, the excitation of which is adjusted so that when the output of the second or modulator stage is at its minimum value the net ampere-turns applied to the core of the third-stage saturating reactor is zero, under which condition the output of the third stage, and therefore the current in the potential divider, is likewise zero.

<sup>9</sup> See Figure 10 of reference 3.

The polarized amplifier used in the first stage is shown only in block diagram form to simplify the illustration of the principle of the linear amplifier circuit and is of the type shown in Figure 14.

The blocking limiter of Figure 16 is also included. This makes it possible for the input signal to be applied instantaneously at its maximum value or to be suddenly reduced to zero, without causing any hysteresis zero shift in the polarized amplifier.

In linear amplifiers of this type, there is no difficulty in obtaining an accuracy over the full operating range of within one microampere. That is to say, the difference between the input signal and the fraction of the output that should have the same value, will not, except when the signal is rapidly varying, exceed one microampere.

To simplify the description and explanation, only a single stage of amplification is shown in Figure 24. However, any required number of additional stages of amplification may be incorporated in the linear amplifier so as to step up the output power to any desired level. Amplifiers of this type can be built with outputs in the kilowatt range.

It will be noted that the action of the linear-response magnetic amplifier is very similar to that of the rotary device known as the amplidyne. While it is possible that the magnetic amplifier may not at present compare favorably with the amplidyne in speed of response, it embraces a range of input and output power level that would require a combination of both amplidyne and electronic apparatus. It may also present some advantage in applications where for any reason it may be desired to avoid rotating parts, commutators, and brushes.

---

### ***Recent Telecommunication Developments***

#### **High-Frequency Measurements Conference**

**A** HIGH-FREQUENCY Measurements Conference will be held in Washington, District of Columbia, on January 10-12, 1951. The program will include about 25 technical papers, an evening demonstration, a luncheon, and inspection tours to nearby scientific institutions. To encourage authors to report their very latest findings, preprints of papers will not be issued and only brief abstracts will be published after the meeting.

The conference is sponsored by the National Bureau of Standards and the Joint Committee on High-Frequency Measurements of the American Institute of Electrical Engineers and the Institute of Radio Engineers of which Professor Ernst Weber of the Microwave Research Institute of the Polytechnic Institute of Brooklyn, at Brooklyn, New York, is chairman.

#### **Fahie Premium to Flowers and Weir**

**T**HE INSTITUTION of Electrical Engineers has awarded its Fahie Premium for the most meritorious paper in the fields of telephony and telegraphy published by the Institution during the preceding year to Messrs. T. H. Flowers and D. A. Weir for their paper on "The Influence of

Signal Imitation on the Reception of Voice-Frequency Signals". This contribution appeared in the May, 1949, issue of the *Proceedings of the Institution of Electrical Engineers* and was reprinted in the December, 1949, number of *Electrical Communication*.



# Phase Distortion in Feeders\*

By L. LEWIN

*Standard Telecommunication Laboratories, Limited, London, England,*

J. J. MULLER, and R. BASARD

*Le Matériel Téléphonique, Paris, France*

## 1. Introduction

IT IS WELL KNOWN that variations of delay time with frequency for any unit of a radio system can cause a distortion of the signal. A mismatch at the end of a long feeder is one such source of variable delay, and an investigation of its effects has been initiated by Friis.<sup>1</sup> He finds the phase delay for a constant-frequency input as a function of that frequency, but the results are not immediately applicable to frequency-modulated signals, and it is necessary to apply the variable-frequency analysis of Carson and Fry and others.<sup>2</sup> When this is done, a serious limitation of the method becomes apparent: with feeder lines of any appreciable length, the phase changes so rapidly with frequency that the first few terms of the expansion are insufficient, with the result that for a complete result the work becomes very clumsy and laborious. A fresh approach therefore seems desirable. This is provided by considering the system to support a series of running waves of various instantaneous frequencies, and reflected within the confines of the feeder, rather than the constant-frequency standing-wave formulation used by Friis.

## 2. Production of Waves in the Feeder

Let us consider an injected signal of carrier frequency  $f_c$  frequency modulated by a single-tone video signal  $\Delta f \cdot \sin(2\pi f_a t)$ , where  $\Delta f$  and  $f_a$  are respectively the peak frequency deviation and the modulating frequency. We write  $\omega_c = 2\pi f_c$ ,  $\Delta\omega = 2\pi\Delta f$ , and  $\omega_a = 2\pi f_a$ , so that the modu-

\* Reprinted from *Wireless Engineer*, v. 27, pp. 143-145; May, 1950.

<sup>1</sup> H. T. Friis, "Micro-Wave Repeater Research," *Bell System Technical Journal*, v. 27, pp. 183-246; April, 1948.

<sup>2</sup> J. R. Carson and T. C. Fry, "Variable Frequency Electric Circuit Theory with Application to the Theory of Frequency Modulation," *Bell System Technical Journal*, v. 16, pp. 513-540; October, 1937.

lated carrier can be written as

$$\cos \left\{ \int (\omega_c + \Delta\omega \sin \omega_a t) dt \right\} = \cos \{ \omega_c t + s(t) \},$$

where  $s(t) = -(\Delta\omega/\omega_a) \cos \omega_a t$ .

If the signal is sent along a line of length  $l$ , a portion of the wave, depending on the mismatch at the far end, is reflected and returns towards the transmitter. If the latter is also mismatched, a portion of the reflected wave is sent out along the line again and supplements the wave actually being transmitted at the time, and which is of a slightly different frequency, since the wave is frequency modulated. The wave leaving the feeder at any instant is accordingly a composite one, being composed of waves generated at different times, but delayed by reflections within the feeder. There will, of course, be multiple reflections, but if the mismatches are small, the dominant interference comes from that wave that has been reflected but once from each end of the feeder before leaving it.

If we introduce the time delay  $\tau$  along the feeder and the group velocity  $v$  of the waves, then  $\tau = l/v$  and we find for the transmitted signal  $S(t)$

$$S(t) = \cos \{ \omega_c t + s(t) \} + r_1 r_2 e^{-2\alpha l} \cos \{ \omega_c (t - 2\tau) + s(t - 2\tau) + \theta_1 + \theta_2 \}. \quad (1)$$

Here,  $r_1$ ,  $r_2$  and  $\theta_1$ ,  $\theta_2$  are respectively the reflection coefficients and phase changes occurring at each end of the feeder, whilst  $\alpha$  is the attenuation constant for the line. Unless  $\tau$  is such that  $s(t - 2\tau) = s(t)$  (a case treated later), the two terms of (1) will be of different frequencies, so that the composite signal will involve  $s(t)$  in a non-linear way, with consequent distortion.

## 3. Production of Phase Distortion

At reception, we assume that the wave is first amplitude limited and then put through the dis-

criminator networks, which produce an output proportional to the instantaneous frequency of the signal  $S(t)$ . Now (1) can be put in the form

$$S(t) = A \cos \{ \omega_c t + s(t) \} + B \sin \{ \omega_c t + s(t) \},$$

where

$$A = 1 + r_1 r_2 e^{-2\alpha l} \cos \{ 2\omega_c \tau + s(t) - s(t-2\tau) - \theta_1 - \theta_2 \} \quad (2)$$

and

$$B = r_1 r_2 e^{-2\alpha l} \sin \{ 2\omega_c \tau + s(t) - s(t-2\tau) - \theta_1 - \theta_2 \}.$$

This follows by putting

$$\begin{aligned} &\omega_c(t-2\tau) + s(t-2\tau) + \theta_1 + \theta_2 \\ &= \{ \omega_c t + s(t) \} - \{ 2\omega_c \tau + s(t) - s(t-2\tau) - \theta_1 - \theta_2 \} \end{aligned}$$

in the second term of (1) and expanding.

Equation (2) can be re-written

$$S(t) = (A^2 + B^2)^{\frac{1}{2}} \cos \{ \omega_c t + s(t) - \phi \},$$

where  $\tan \phi = B/A$ . The amplitude limiting removes the factor  $(A^2 + B^2)^{\frac{1}{2}}$  so that  $\phi$  represents the phase distortion due to the mismatches. Since  $B \ll r_1 r_2 e^{-2\alpha l}$ , which is assumed small, and  $A \approx 1$ ,  $\phi$  will be small. This gives the approximation  $\phi \approx B$ .

Now the output of the discriminator networks is proportional to the instantaneous frequency of the amplitude-limited signal, and hence to  $\omega_c + s'(t) - d\phi/dt$ . Of this,  $\omega_c$  can be ignored while  $s'(t) = \Delta\omega \sin(\omega_a t)$  represents the recovered signal. The last term contains the distortion. Carrying out the differentiation we get an output

$$\Delta\omega \cdot \sin(\omega_a t) - d/dt [r_1 r_2 e^{-2\alpha l} \sin \{ 2\omega_c \tau + s(t) - s(t-2\tau) - \theta_1 - \theta_2 \}]. \quad (3)$$

Now  $s(t) - s(t-2\tau) = 2\Delta\omega\tau$ .

$$\sin \{ \omega_a(t-\tau) \} \sin(\omega_a \tau) / \omega_a \tau.$$

The quantity  $2\Delta\omega\tau \cdot \sin(\omega_a \tau) / \omega_a \tau$ , which occurs frequently, will be denoted by  $y$ . Expanding (3) we get for the output

$$\begin{aligned} &\Delta\omega \sin(\omega_a t) - r_1 r_2 e^{-2\alpha l} \sin(2\tau\omega_c - \theta_1 - \theta_2) d/dt \\ &\quad [\cos [y \sin \{ \omega_a(t-\tau) \}]] + r_1 r_2 e^{-2\alpha l} \\ &\cos(2\tau\omega_c - \theta_1 - \theta_2) d/dt [\sin [y \sin \{ \omega_a(t-\tau) \}]]. \end{aligned} \quad (4)$$

#### 4. Harmonic Production

If we use in (4) the Fourier-Bessel expansion of  $\sin[y \sin \{ \omega_a(t-\tau) \}]$  and  $\cos[y \sin \{ \omega_a(t-\tau) \}]$ , we can find the various harmonics produced. Ignoring the small amount of recovered signal that appears from the distortion terms, we find

$$\left. \begin{aligned} &\text{Recovered Signal} \\ &\quad \Delta\omega \{ \sin(\omega_a t) \}, \\ &\text{Second Harmonic} \\ &\quad 2r_1 r_2 e^{-2\alpha l} (2\omega_a) J_2(y) \sin(\theta) \\ &\quad \quad \quad \times [\sin \{ 2\omega_a(t-\tau) \}], \\ &\text{Third Harmonic} \\ &\quad 2r_1 r_2 e^{-2\alpha l} (3\omega_a) J_3(y) \sin(\theta + \pi/2) \\ &\quad \quad \quad \times [\cos \{ 3\omega_a(t-\tau) \}], \\ &\text{Fourth Harmonic} \\ &\quad 2r_1 r_2 e^{-2\alpha l} (4\omega_a) J_4(y) \sin(\theta + \pi) \\ &\quad \quad \quad \times [\sin \{ 4\omega_a(t-\tau) \}], \text{ etc.} \end{aligned} \right\} \quad (5)$$

where  $\theta = 2\tau\omega_c - \theta_1 - \theta_2$ .

In this equation, the last factor in square brackets is the form of the harmonic, and the rest of the expression is its amplitude.  $J_2(y)$ ,  $J_3(y)$ , etc., are Bessel functions, and are tabulated in, for example "Tables of Functions," pages 156 *et seq.* by Jahnke-Emde. All the harmonics are delayed by an amount  $\tau$  with respect to the fundamental. The terms  $\sin(\theta + n\pi/2)$  are normally indeterminate. They depend not only on the unknown phase changes  $\theta_1$  and  $\theta_2$  but also on the precise electrical length of the feeder and the radio frequency. In a multi-repeater system, such terms would appear randomly phased, and hence would add up "power-wise" from repeater to repeater. It is convenient, therefore, to give them their root-mean-square values of  $1/2^{\frac{1}{2}}$ . But it should always be borne in mind that for any one particular set-up these terms will be quite definite and can be, for example, zero for certain frequencies or lengths of feeder.

Accordingly, we find

$$\left. \begin{aligned} &\frac{2\text{nd}^{\text{th}} \text{ Harmonic}}{\text{Fundamental}} = 2^{\frac{1}{2}} r_1 r_2 e^{-2\alpha l} (2\omega_a / \Delta\omega) J_2(y) \\ &\frac{3\text{rd} \text{ Harmonic}}{\text{Fundamental}} = 2^{\frac{1}{2}} r_1 r_2 e^{-2\alpha l} (3\omega_a / \Delta\omega) J_3(y) \\ &\frac{n\text{th} \text{ Harmonic}}{\text{Fundamental}} = 2^{\frac{1}{2}} r_1 r_2 e^{-2\alpha l} (n\omega_a / \Delta\omega) J_n(y), \end{aligned} \right\} \quad (6)$$

where  $y = 2\Delta\omega\tau \cdot \sin(\omega_a\tau)/\omega_a\tau$ . To get the harmonic margins in decibels, we simply take 20 log<sub>10</sub> of the above expressions.

It is clear from (6) that the margins of the harmonics with respect to the fundamental depend on the modulating frequency  $\omega_a$ . In many cases,  $\omega_a$  is small, so that  $y \approx 2\Delta\omega\tau$  and the harmonics are proportional to the modulating frequency  $\omega_a$ . Also, the harmonics are all delayed by  $\tau$  with respect to the recovered signal. Since  $\tau$  is different for different repeater stations, it follows that there can be no component of distortion adding up in phase from repeater to repeater, and there will be therefore no "voltage-rise" component of third-harmonic distortion.

These properties of the distortion are different from those that arise when the signal output can be taken as a simple power-series expansion of the input. It should not, therefore, be surprising if the absolute value of time-delay variation with frequency should turn out not to be a suitable measure of the distortion.

For very short runs,  $y$  is small, and  $J_2(y) \approx y^2/8$ . Hence (5) gives, for the second harmonic

$$2r_1r_2e^{-2\alpha l}\omega_a(\Delta\omega)^2\tau^2\left\{\frac{\sin(\omega_a\tau)}{\omega_a\tau}\right\}^2 \sin(2\tau\omega_c - \theta_1 - \theta_2).$$

Apart from the absence of the factor  $\{\sin(\omega_a\tau)/\omega_a\tau\}^2$ , which is usually very close to 1, and the omission of  $\theta_1$  and  $\theta_2$ , this is the same result as can be obtained from the formula for the phase given on page 62 of Friis's paper<sup>1</sup> by the use of the first few terms of the quasi-stationary-state expansion. But the expression for the variation of time delay with frequency increases proportionally to the length of feeder no matter how long it may be, while  $J_2(y)$  does not rise indefinitely as  $y^2/8$ , but reaches a maximum of about 0.486 at  $y \approx 3$ , whereafter it decreases again and oscillates about zero. For this reason, it is felt that the time-delay variation is not a suitable quantity to use when discussing the distortion arising from feeder mismatches unless the feeder is very short, and conclusions drawn about the unusability of very long feeders may not necessarily be sound.

Unless the feeder length is comparable with the wavelength of the modulating frequency  $\omega_a$ ,  $\omega_a\tau$  will be small, and  $\sin \omega_a\tau/\omega_a\tau$  can be replaced by unity. Hence  $y \approx 2\Delta\omega\tau$ . However, if  $\omega_a\tau = \pi$ ,  $y = 0$  and there is no harmonic distortion

whatsoever. This is easily seen to be so from (1) since the second term is merely a small multiple of the first, which is accordingly transmitted without phase distortion. This phenomenon will not usually occur for more complex modulating signals, however.

### 5. Example

Consider a wave of radio-frequency carrier wavelength  $\lambda = 7$  centimetres, conveyed over a feeder consisting of 50 feet of 2-inch by  $\frac{2}{3}$ -inch brass waveguide. Let the peak frequency deviation of the modulation be 3 megacycles per second, the video band being 800 kilocycles per second wide. It is required to find the distortion at the top of the band. The voltage standing-wave ratios at the ends of the feeder will be taken as 0.95 and 0.65, and the attenuation along the guide as 1 decibel each way. The group velocity is  $3 \times 10^{10} \cdot (1 - \lambda^2/4a^2)^{\frac{1}{2}}$  with  $a = 2$  inches.

Hence  $v = 2.1 \times 10^{10}$  centimetres per second and  $\tau = 0.71 \times 10^{-7}$  second.

We use a modulating tone of frequency 0.4 megacycle per second in order that its 2nd harmonic may be at the top of the band.

$$\begin{aligned} \text{Then } \omega_a\tau &= 2\pi \times 0.4 \times 0.071 \\ &= 0.178 \text{ or } 10 \text{ degrees,} \end{aligned}$$

$$\sin(\omega_a\tau)/\omega_a\tau = 0.995$$

$$\begin{aligned} y &= 2\Delta\omega\tau \cdot \sin(\omega_a\tau)/\omega_a\tau \\ &= 2.66. \end{aligned}$$

$$J_2(y) = 0.46$$

$$r_1r_2 = \frac{1 - 0.95}{1 + 0.95} \cdot \frac{1 - 0.65}{1 + 0.65} = 5.4 \times 10^{-3}$$

$$\begin{aligned} \frac{\text{2nd Harmonic}}{\text{Fundamental}} &= 5.4 \times 10^{-3} \times (0.8/3) \times 0.45 \\ &\quad \times 10^{-0.1} \times 2^{\frac{1}{2}} \equiv 63 \text{ decibels.} \end{aligned}$$

The ratio of third-to-second harmonic, when each in turn is arranged to occur at the top of the band (by a suitable choice of  $\omega_a$  for each), is  $J_3(2.66)/J_2(2.66) = 0.5$ . The third is thus 6 decibels down on the second. Since  $J_n(y)$  decreases for  $n$  greater than  $y$ , the higher harmonics rapidly become negligible in this example.

Thus  $J_4(2.66)/J_2(2.66) = 0.17$ , which is equivalent to a 15-decibel margin of fourth-to-second harmonic.

Equality of third-to-second harmonic would obtain for  $y=3.75$ ; i.e., for a length of about 70 feet in this example. For greater lengths, the second harmonic drops rapidly, becoming zero at 100 feet, the third and subsequently the higher harmonics becoming dominant.

#### 6. Connection Between Cross-Talk and Harmonics

This subject will be dealt with in detail in a forthcoming paper. However, it is obvious from

the above example and from Section 4 that the variation of time delay is not a suitable measure of the amount of harmonics produced (except for very small feeder lengths), and it transpires that the harmonic production is equally unsuitable (except in the case of the preponderance of second and third) to describe the cross-talk.

#### 7. Additional Reference

B. van der Pol, "Fundamental Principles of Frequency Modulation," *Journal of The Institution of Electrical Engineers*, Part 3, v. 93, pp. 153-158; May, 1946.

### Recent Telecommunication Development

#### 400-Kilovolt Direct-Current Testing Equipment

DISPLAYED at the British Industries Fair in London was a 400-kilovolt direct-current test setup designed and built by Standard Telephones and Cables for use in the power-cable laboratories at North Woolwich.

SenTerCel selenium rectifiers, requiring no auxiliary apparatus, provide a robust, compact, and simple arrangement having unusual flexibility, particularly with regard to the maximum voltage per stage, which is definitely limited with thermionic valves. The equipment operates normally as a two-stage Cockcroft type rectifier.

Either the positive or negative terminal may be earthed or center-tapped capacitors may be charged with the mid-point earthed. The transformer may be used separately for 200-kilovolt alternating-current testing.

All high-voltage components are mounted in cylindrical tanks of insulating material having metal end fittings to which the electrical contacts are made. This eliminates the need for separate high-tension terminal bushings and permits the units to be

stacked. The transformer and series capacitor form one of the columns shown and the other two contain the positive and negative arms of the rectifier supported on tubular standoff insulators rated to withstand the full output voltage. Each rectifier arm consists of two oil-filled 100-kilovolt half-wave units in series.

The control gear for the rectifier set is housed in one section of a two-pedestal control desk. The remaining space is for the low-tension accessories of an impulse generator with which the equipment will also be used.



## In Memoriam

**F**RANK GILL was born at Castletown, Isle of Man, in 1866 and died on October 25, 1950, at the age of 84 years at Geneva, Switzerland, while attending meetings of the Comité Consultatif International Téléphonique. A pioneer in telephony, he was a contemporary and friend of both Alexander Graham Bell and Oliver Heaviside.

At the age of 16, he went to work for the United Telephone Company and in 1896 was placed in charge of the activities of the National Telephone Company in Ireland. In 1902, he returned to London as engineer-in-chief. The government had decided not to renew the franchise of the National Telephone Company when it expired in 1911, so he was faced during this decade with the task of limiting capital expenditures in view of the termination of the franchise while at the same time improving the system to meet competition from municipalities that had entered the field and from the British Post Office that had operated a telephone system throughout the life of the franchise. The extent of his success against most formidable obstacles affords some measure of his singleness of purpose, but it is certain that his qualities of patience, tact, persistence, ingenuity, and imperturbability were tested to the limit during this period.

When, in 1912, the Post Office took over everything but the 12 senior executive officers of the National Telephone Company, Mr. Gill and Mr. W. W. Cook, assistant chief engineer of the company, formed the consulting firm of Gill and Cook. It engaged in telephone work in Argentina, Brazil, Portugal, Turkey, United States of America, and other countries.

After serving in the Ministry of Munitions during the first World War, he was European chief engineer from 1919 to 1928 of the International Western Electric Company, the name of which was changed to International Standard Electric Corporation in 1925. During 1925 and 1926, he also served as executive vice president of the Compañía Telefónica Nacional de España

and was responsible for initiating the building of the present modern Spanish telephone system. Later he undertook the reconstruction of the plant of the Shanghai Telephone Company.

In 1922, he was elected president of the Institution of Electrical Engineers of which he had been a member since 1891. It was his presidential address to this organization that led to the formation two years later of the Comité Consultatif International Téléphonique. The successful establishment of long-distance telephony in Europe is due in no small part to the efforts of this committee. It was while attending meetings of the Comité Consultatif International Téléphonique that he died.

At the time of his death, Sir Frank was chairman of Standard Telephones and Cables, Limited; International Marine Radio Company, Limited; Standard Telecommunication Laboratories, Limited; and Creed and Company, Limited. He was a director and vice president of the International Standard Electric Corporation.

He was a member of the Institution of Civil Engineers, past president and an Honorary Member of the Institution of Electrical Engineers, Fellow of the American Institute of Electrical Engineers, Honorary Member of the Institute of Royal Engineers, Member of the Royal Institution, and a Member of the Société des Ingenieurs Civils de France and of the Société Française des Electriciens.

He served for five years on an advisory council to the Archbishop of Canterbury and was a director of the British and Foreign Bible Society.

For his services during the first World War, he was made an Officer of the Order of the British Empire. In 1941, he was appointed a Knight Commander of the Most Distinguished Order of St. Michael and St. George for services in the development of the telephone industry and of international telephony. He was awarded the Spanish Royal Order of Isabel la Católica, and the Order of the Brilliant Star with Special Rosette by the Republic of China.



SIR FRANK GILL, K.C.M.G., O.B.E.

## Contributors to This Issue



E. J. AGNEW

E. J. AGNEW was born in Jordan, New York. After receiving the E.E. degree from Syracuse University in 1924, he joined the engineering staff of the Western Union Telegraph Company.

His early work was on the protecting of telegraph circuits from the effects of lightning and power-line disturbances. Since 1936, he has been active in the design of circuit arrangements for reperforator switching systems and has participated in the testing and initial operation of most of the new reperforator switching centers.

Mr. Agnew has prepared text material and taught many classes in the technical aspects of automatic switching.

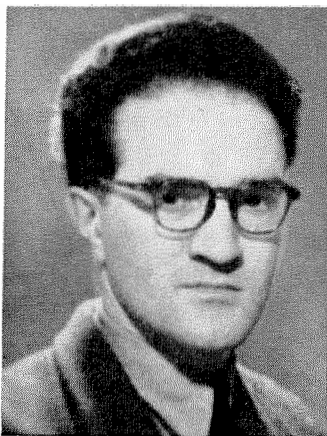

ROBERT BASARD

ROBERT BASARD was born at Lyons, France, on November 3, 1919.

After studying at Lyons University, Ecole Supérieure d'Electricité of Paris, and the Institute Electrotechnique of Grenoble, he joined the Laboratoire Central de Télécommunications in Paris in 1944. He is now working on radio links at Le Matériel Téléphonique.

• • •

JOHN H. BRYANT was born at Baird, Texas, on April 15, 1920. He received the B.S. degree in electrical engineering from the A&M College of Texas in 1942 and the Ph.D. degree from the University of Illinois in 1949.

From 1942 to 1946, he served as a commissioned officer in the Signal Corps of the United States Army.

For the summer of 1947, he was temporarily employed by the vacuum tube department of Federal Telecommunication Laboratories and in 1949 joined the staff as a project engineer. Dr. Bryant has been engaged in a study of vacuum tubes.

He is a member of Sigma Xi, American Physical Society, and Institute of Radio Engineers.

• • •

ALAN S. FITZGERALD was born in 1896 in England. After studying electrical engineering at Finsbury College in London, he entered the shops of the British Thomson-Houston Company. This work, interrupted by military service during the first world war, was terminated in 1924, when he came to the United States to join the General Electric Company.

In 1932, Mr. FitzGerald became an independent development and research engineer with laboratories at Swarthmore College and, later, at Haverford College. In 1950, he moved to San Francisco, California.

His researches cover a wide range of subjects and have resulted in the publication of numerous technical papers and the issuance of 85 United States patents. In 1924, he was given the John Hopkinson award of the Institution of Electrical Engineers for

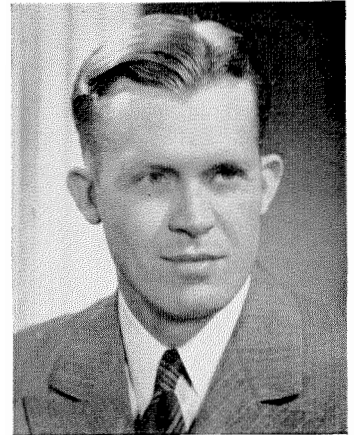

JOHN H. BRYANT

a paper on the protection of transmission lines. In 1949, he was awarded the Louis Edward Levy medal of the Franklin Institute for his papers on magnetic amplifiers.

Mr. FitzGerald is a member of the Institution of Electrical Engineers, American Institute of Electrical Engineers, Franklin Institute, and Sigma Xi. He is registered as a professional electrical engineer in California.

• • •

JACOB SUTER JAMMER was born in Cumberland, Maryland, on April 23, 1898. He received the B.S. degree in electrical engineering from Johns Hopkins University in 1918.



ALAN S. FITZGERALD



JACOB S. JAMMER

phone and Telegraph Corporation in 1945 and was appointed general commercial director of International Standard Electric Corporation the next year. He is responsible for sales promotion, contractual relations, market surveys, planning, and export sales from the United States. In 1947, he was placed in charge of the development of sales in the United States of automatic reservation systems, totalizers, automatic pneumatic tube systems, and printing telegraph equipment.

• • •

LEONARD LEWIN. A biography of Mr. Lewin appears on page 84 of the March, 1950, issue.

• • •

JEAN JACQUES MULLER was born in Bâle, Switzerland, on September 6, 1910. After studying at the Ecole Centrale des Arts et Manufactures of Paris, he obtained a diploma of doctor in technical sciences from the Federal Polytechnical School at Zurich.

From 1935 to 1940, he did research and development work on decimetric waves and television at the Federal Polytechnic School. He then entered Les Laboratoires, Le Matériel Téléphonique in Paris where he worked on microwave installations and on the design and construction of radio transmitters. He is now head of the technical service of the radio division of Le Matériel Téléphonique.

• • •

PETER C. SANDRETTO was born in Pont Canavese, Italy, on April 14, 1907. He received the BSEE and EE degrees from Purdue University in 1930 and 1938. He also did graduate work at Northwestern University and was graduated from the Air Staff Course of the Command and General Staff School at Fort Leavenworth in 1946.

From 1925 to 1930, he was a radio operator and engineer for several radio broadcasting stations. During the following two years, he was with Bell Telephone Laboratories. In 1932, he joined United Air Lines and served as superintendent of their communications laboratories until 1942, when he entered the U. S. Air Forces with the



PETER C. SANDRETTO

rank of major, advancing later to brigadier general.

He joined the I. T. & T. System in 1946 and is at present serving as assistant technical director of Federal Telecommunication Laboratories.

During the war, he was decorated with the Bronze Star for his achievements in the Central Pacific. He is a member of Eta Kappa Nu, honorary electrical engineering fraternity, a Senior Member of the Institute of Radio Engineers, Member of the Institute of Navigation, and an Associate Member of the Institution of Electrical Engineers. He has served on various committees of the Radio Technical Commission for Aeronautics ever since its inception in 1935. He is the author of the text book "Principles of Aeronautical Radio Engineering."

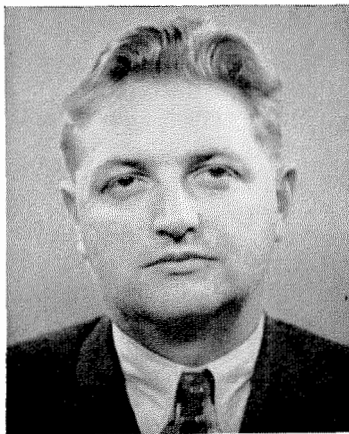

J. J. MULLER

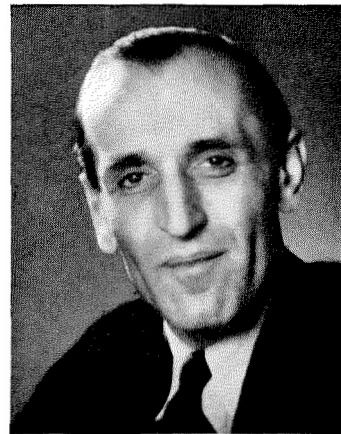

WOLFGANG STIEBER



WOLFGANG STIEBER was born in Leipzig, Germany, in 1909. He received the degree of Dipl.-Ing. in electrical engineering in 1933 from Technische Hochschule in Munich and studied economics and business administration at the University of Leipzig during the following year.

From 1934 to 1947, he worked for Carbone A-G and then joined the International Telephone and Telegraph

System. In addition to his activities on pneumatic-tube systems, he served with the Mackay Radio and Telegraph Company on the installation of the international radio terminal at Frankfurt (Main). Since 1949, Mr. Stieber has been in the United States as the technical representative of Mix and Genest Aktiengesellschaft in cooperation with the International Standard Trading Corporation.

W. R. TRIEM was born at Pittsburgh, Pennsylvania, on October 21, 1886. He received a degree in civil engineering from Ohio State University in 1910.

On graduation from college, he joined the engineering staff of the Pennsylvania Railroad and progressed through several positions to his present one of general superintendent of telegraph, which he assumed in 1936.

# INTERNATIONAL TELEPHONE AND TELEGRAPH CORPORATION

## Associate Manufacturing and Sales Companies

### United States of America

International Standard Electric Corporation, New York, New York  
Federal Telephone and Radio Corporation, Clifton, New Jersey  
International Standard Trading Corporation, New York, New York  
Capehart-Farnsworth Corporation, Fort Wayne, Indiana

### Great Britain and Dominions

Standard Telephones and Cables, Limited, London, England  
Creed and Company, Limited, Croydon, England  
International Marine Radio Company Limited, Croydon, England  
Kolster-Brandes Limited, Sidcup, England  
Standard Telephones and Cables Pty. Limited, Sydney, Australia  
Silovac Electrical Products Pty. Limited, Sydney, Australia  
Austral Standard Cables Pty. Limited, Melbourne, Australia  
New Zealand Electric Totalisators Limited, Wellington, New Zealand  
Federal Electric Manufacturing Company, Ltd., Montreal, Canada

### South America

Compañía Standard Electric Argentina, Sociedad Anónima, Industrial y Comercial, Buenos Aires, Argentina  
Standard Eléctrica, S.A., Rio de Janeiro, Brazil  
Compañía Standard Electric, S.A.C., Santiago, Chile

### Europe and Far East

Vereinigte Telephon- und Telegraphenfabriks Aktiengesellschaft Czeija, Nissl & Co., Vienna, Austria  
Bell Telephone Manufacturing Company, Antwerp, Belgium  
China Electric Company, Limited, Shanghai, China  
Standard Electric Aktieselskab, Copenhagen, Denmark  
Compagnie Générale de Constructions Téléphoniques, Paris, France  
Le Matériel Téléphonique, Paris, France  
Les Téléimprimeurs, Paris, France  
C. Lorenz, A.G. and Subsidiaries, Stuttgart, Germany  
Mix & Genest Aktiengesellschaft and Subsidiaries, Stuttgart, Germany  
Süddeutsche Apparatefabrik Gesellschaft m.b.H., Nuremberg, Germany  
Nederlandsche Standard Electric Maatschappij N.V., The Hague, Netherlands  
Fabbrica Apparecchiature per Comunicazioni Elettriche, Milan, Italy  
Standard Telefon og Kabelfabrik A/S, Oslo, Norway  
Standard Eléctrica, Lisbon, Portugal  
Compañía Radio Aérea Marítima Española, Madrid, Spain  
Standard Eléctrica, S.A., Madrid, Spain  
Aktiebolaget Standard Radiofabrik, Stockholm, Sweden  
Standard Telephone et Radio S.A., Zurich, Switzerland

## Telephone Operating Systems

Compañía Telefónica Argentina, Buenos Aires, Argentina  
Compañía Telegráfico-Telefónica Comercial, Buenos Aires, Argentina  
Compañía Telegráfico-Telefónica del Plata, Buenos Aires, Argentina  
Companhia Telefônica Nacional, Porto Alegre, Brazil  
Companhia Telefônica Paranaense S. A., Curitiba, Brazil  
Compañía de Teléfonos de Chile, Santiago, Chile  
Compañía Telefónica de Magallanes S.A., Punta Arenas, Chile  
Cuban American Telephone and Telegraph Company, Havana, Cuba  
Cuban Telephone Company, Havana, Cuba  
Compañía Peruana de Teléfonos Limitada, Lima, Peru  
Puerto Rico Telephone Company, San Juan, Puerto Rico  
Shanghai Telephone Company, Federal Inc. U.S.A., Shanghai, China

## Radiotelephone and Radiotelegraph Operating Companies

Compañía Internacional de Radio, Buenos Aires, Argentina  
Compañía Internacional de Radio Boliviana, La Paz, Bolivia  
Companhia Radio Internacional do Brasil, Rio de Janeiro, Brazil  
Compañía Internacional de Radio, S.A., Santiago, Chile  
Radio Corporation of Cuba, Havana, Cuba  
Radio Corporation of Porto Rico, San Juan, Puerto Rico

## Cable and Radiotelegraph Operating Companies

(Controlled by American Cable & Radio Corporation, New York, New York)

The Commercial Cable Company, New York, New York<sup>1</sup>  
Mackay Radio and Telegraph Company, New York, New York<sup>2</sup>  
All America Cables and Radio, Inc., New York, New York<sup>3</sup>  
Sociedad Anónima Radio Argentina, Buenos Aires, Argentina<sup>4</sup>

<sup>1</sup>Cable service. <sup>2</sup>International and marine radiotelegraph services.  
<sup>3</sup>Cable and radiotelegraph services. <sup>4</sup>Radiotelegraph service.

## Laboratories

Federal Telecommunication Laboratories, Inc., Nutley, New Jersey  
Standard Telecommunication Laboratories, Limited, London, England  
Laboratoire Central de Télécommunications, Paris, France