

Circulats

M. B. B. Jacobsen 2535

# ELECTRICAL COMMUNICATION

*Technical Journal of the  
International Telephone and Telegraph Corporation  
and Associate Companies*

●

COMITÉ CONSULTATIF INTERNATIONAL TÉLÉPHONIQUE  
INDUSTRIAL TELEVISION SYSTEM  
ILS-2 INSTRUMENT LANDING EQUIPMENT  
IMPEDANCE-FREQUENCY MEASUREMENT ON COAXIAL CABLES  
A.R.I.5272 AIRCRAFT RADIO SET  
335-MEGACYCLE EQUISIGNAL GLIDE SLOPES  
RECIPROCITY BETWEEN GENERALIZED MUTUAL IMPEDANCES  
FOURIER TRANSFORMS IN CIRCUIT ANALYSIS  
TELEPHONE STATISTICS OF THE WORLD



Volume 27

JUNE, 1950

Number 2



# ELECTRICAL COMMUNICATION

Technical Journal of the  
INTERNATIONAL TELEPHONE AND TELEGRAPH CORPORATION  
and Associate Companies

H. P. WESTMAN, Editor

F. J. MANN, Managing Editor

J. E. SCHLAIKJER, Editorial Assistant

## REGIONAL EDITORS

E. G. PORTS, Federal Telephone and Radio Corporation, Clifton, New Jersey  
B. C. HOLDING, Standard Telephones and Cables, Limited, London, England  
P. F. BOURGET, Laboratoire Central de Télécommunications, Paris, France  
H. B. WOOD, Standard Telephones and Cables Pty. Limited, Sydney, Australia

## EDITORIAL BOARD

H. Busignies    H. H. Buttner    G. Deakin    E. M. Deloraine    W. T. Gibson    Sir Frank Gill  
W. Hatton    E. Labin    A. W. Montgomery    Haraden Pratt    G. Rabuteau  
F. X. Rettenmeyer    T. R. Scott    C. E. Strong    A. E. Thompson    E. N. Wendell    W. K. Weston

Published Quarterly by the

## INTERNATIONAL TELEPHONE AND TELEGRAPH CORPORATION

67 BROAD STREET, NEW YORK 4, N.Y., U.S.A.

Sosthenes Behn, Chairman

William H. Harrison, President

Charles D. Hilles, Jr., Vice President and Secretary

Subscription, \$2.00 per year; single copies, 50 cents

Electrical Communication is indexed in Industrial Arts Index

Copyrighted 1950 by International Telephone and Telegraph Corporation

Volume 27

June, 1950

Number 2

## CONTENTS

	PAGE
FIFTEENTH PLENARY ASSEMBLY OF THE COMITÉ CONSULTATIF INTERNATIONAL TÉLÉPHONIQUE, PARIS, 1949 .....	87
<i>By P. E. Erikson</i>	
INDUSTRIAL TELEVISION SYSTEM .....	101
<i>By R. W. Sanders</i>	
ILS-2 INSTRUMENT LANDING EQUIPMENT .....	112
<i>By R. A. Hampshire and B. V. Thompson</i>	
TEST SET FOR IMPEDANCE-FREQUENCY MEASUREMENT ON COAXIAL CABLES ...	123
<i>By A. F. Boff</i>	
MODIFICATION OF A.R.I.5272 AIRCRAFT RADIO SET .....	138
CHARACTERISTICS AND ADJUSTMENT OF 335-MEGACYCLE EQUIGIGNAL GLIDE SLOPES .....	140
<i>By Sidney Pickles</i>	
RECIPROcity BETWEEN GENERALIZED MUTUAL IMPEDANCES FOR CLOSED OR OPEN CIRCUITS .....	152
<i>By A. G. Clavier</i>	
APPLICATION OF FOURIER TRANSFORMS TO VARIABLE-FREQUENCY CIRCUIT ANALYSIS .....	159
<i>By A. G. Clavier</i>	
TELEPHONE STATISTICS OF THE WORLD .....	165
RECENT TELECOMMUNICATION DEVELOPMENT PHOTOGRAPHIC COPIES AND INDEXES OF ELECTRICAL COMMUNICATION ....	164
CONTRIBUTORS TO THIS ISSUE .....	167



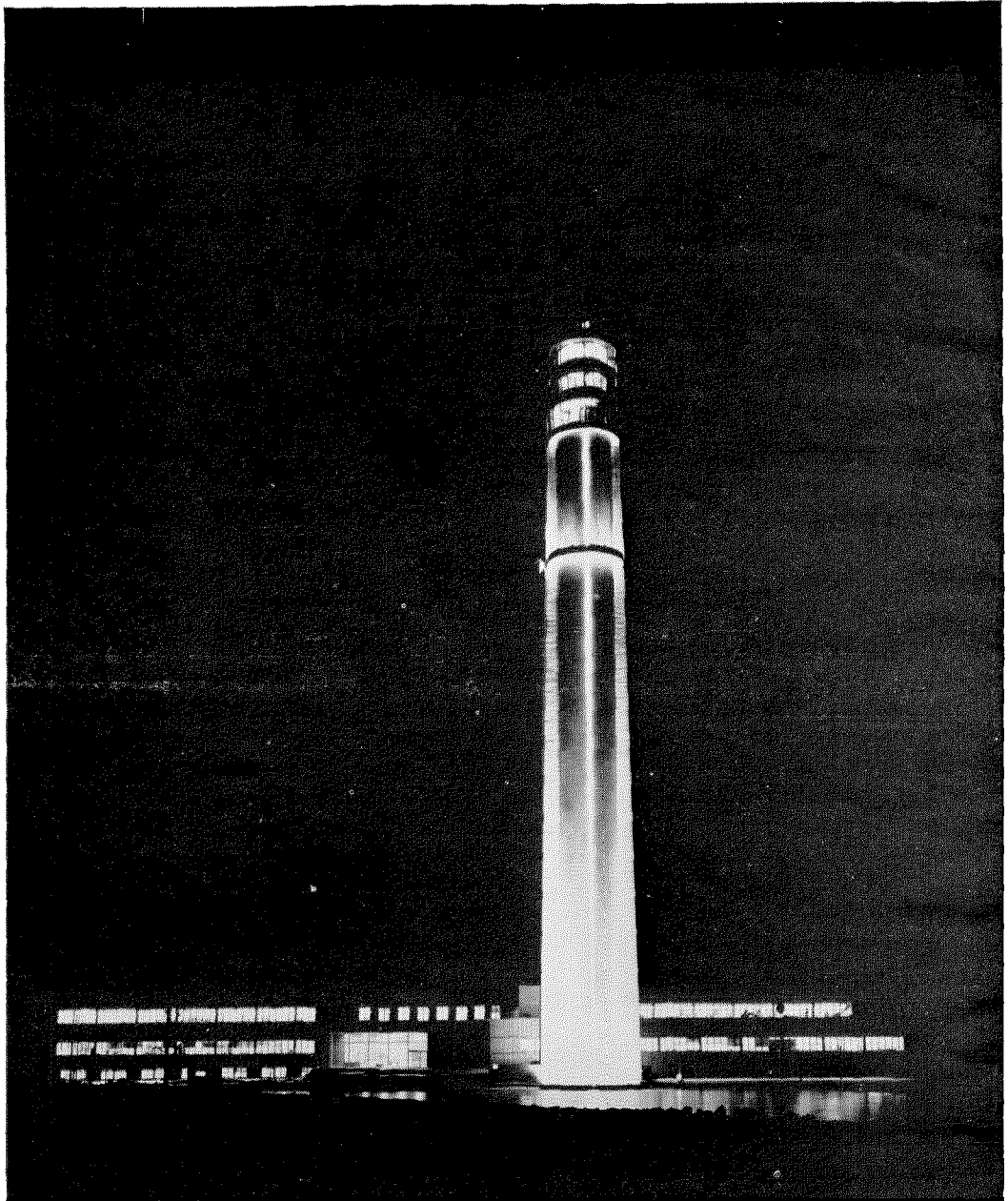

**Night view of Federal Telecommunication Laboratories, Nutley, New Jersey.**

# Fifteenth Plenary Assembly of the Comité Consultatif International Téléphonique, Paris, 1949

By P. E. ERIKSON

*International Standard Electric Corporation, London, England*

THE ANNALS of the Comité Consultatif International Téléphonique will contain a record of at least two events of unusual interest that occurred in 1949. In that year the organization celebrated its twenty-fifth anniversary and held its Fifteenth Plenary Assembly, the first to be conducted under the regulations of the Atlantic City Convention.<sup>1</sup>

Although the agreement among some European nations to form an international consultative committee on long-distance telephony was reached in 1923 at an organizing meeting under the leadership of the late M. Dennery, Inspecteur-Général of the French Posts, Telegraphs, and Telephones, the first plenary assembly was held during April and May of 1924. A year later, the Comité Consultatif International (C.C.I.)—as it was then called—was officially recognized by the International Telegraph Union. It was incorporated in the Union, but was left free to maintain a permanent secretariat in Paris and to establish its own internal regulations and methods of work. It is a matter of good fortune that throughout the 25 years of its existence the continuity of its work has been ensured by the services of its present director, M. Georges Valensi.

## 1. Study Groups

For reference, in connection with the text below, the organization of the Comité Consultatif International Téléphonique is shown in Figure 1. It will be noted that the eight study groups, which are the working bodies of the Comité, each deal with a specific subject and are interlinked through sub-committees to which questions of common interest are referred. Each study group is however responsible for the recommendations submitted to the plenary assembly.

<sup>1</sup>P. E. Erikson, "International Telecommunication Convention, Atlantic City, 1947," *Electrical Communication*, v. 25, pp. 232-236; September, 1948.

Preparatory to the Fifteenth Plenary Assembly the eight study groups held meetings, separately and jointly, during 1947 (Paris), 1948 (Stockholm), and 1949 (Scheveningen). Some of the sub-committees met at various places in the course of the years mentioned. During the week preceding the plenary assembly in Paris, all of the study groups met for a final check-up of the recommendations formulated at the earlier meetings.

## 2. Plenary Assembly

The General Regulations, annexed to the Atlantic City Convention, state that a plenary assembly of a consultative committee shall be presided over by the head of the delegation of the country in which the meetings are held. The chairman, so appointed, shall be assisted by vice chairmen, elected by the plenary assembly. Accordingly M. Lange, Director-General of the French Posts, Telegraphs, and Telephones, became chairman of the Fifteenth Plenary Assembly. The following four vice chairmen were elected to preside over the meetings, dealing with recommendations made by the study groups: Professor Baien (Union of Soviet Socialist Republics), 1st and 2nd study groups on protection against power interference and corrosion; Mr. J. D. H. van der Toorn (Netherlands), 3rd, 4th, and 5th Study Groups on transmission; Mr. A. Moeckli (Switzerland), 6th and 7th Study Groups on operating and tariffs; and Captain J. Legg (United Kingdom), 8th Study Group on signalling and switching. The recommendations of the Committee on Symbols were dealt with under the chairmanship of Captain Legg.

It is beyond the scope of this article to record all of the recommendations adopted at the meeting. It will only be possible in this brief account to bring out the more important features of new or revised recommendations and to indicate the

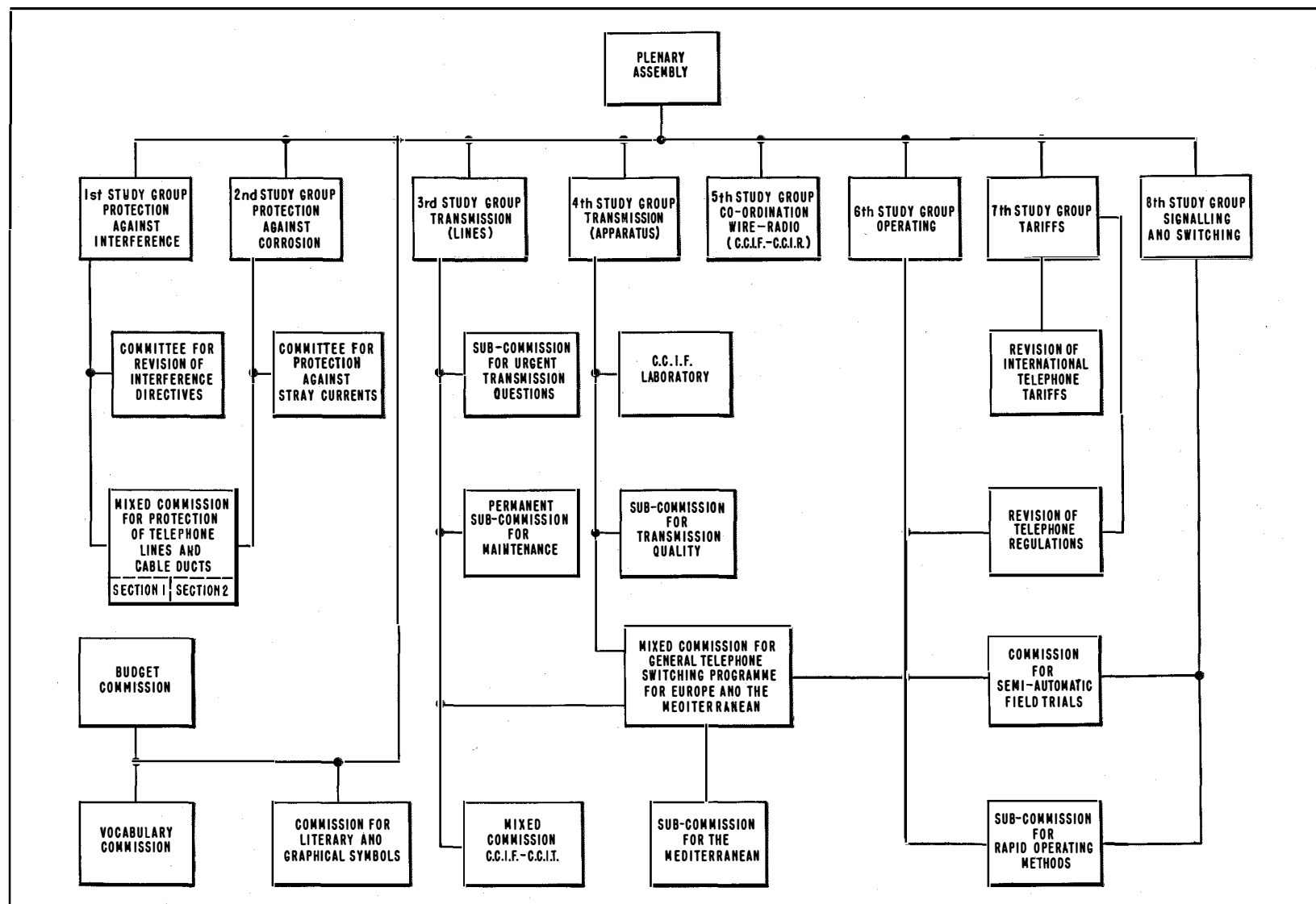

Figure 1—Organization chart for 1949 of the Comité Consultatif International Téléphonique (C.C.I.F.) The C.C.I.R. and C.C.I.T. are the comparable bodies for radio and telegraphy respectively.

trend of new questions that have been approved for future study.

### 3. 1st Study Group (*Protection Against Interference*)

The Plenary Assembly approved three recommendations concerning: (A) a new psophometer, (B) the value of short-circuit current for interference calculations, and (C) transpositions in a power line.

A. The essential clauses of a general specification for the new psophometer, adopted by the Fourteenth Plenary Assembly at Montreux (1946), were approved at Paris. Also, at Paris, certain minor inaccuracies in the schedule of weighting factors, adopted at Montreux, were removed. The permissible tolerances of the weighting factors remain unaltered, but will be subject to further study.

B. For the purpose of calculating the electromotive forces induced in telephone lines during a short circuit in the power line, the effective inducing current has heretofore been taken as 0.7 of the actual earth current. It is now agreed that there is *no* justification for this factor, which in the future will be replaced by a factor of 1.0. The existing limit of 300 volts will be increased in the ratio 0.7:1.0 to 430 volts as a maximum value, as experience has shown it to be unnecessary to make the existing requirement more severe.

C. Transpositions. In the past it has been implied that the length of a complete cycle of transposition should not exceed 36 kilometres (22.4 miles) in cases where three conductors of a power line are arranged so as to form the corners of a specified triangle and 18 kilometres (11.2 miles) for other arrangements of power conductors. It is now agreed that in the future no limit shall be placed on the lengths of such transpositions. Instead, it is recommended that the harmonic voltages and currents in each of the three conductors of a power line shall have the same magnitude. This result can generally be obtained by appropriate transpositions.

The 1st Study Group has 17 questions for continued study on its agenda covering practically the whole field of protection against power interference. Three new questions were approved for study by the Fifteenth Plenary Assembly, all relating to the three subjects outlined above, namely:

A. Insertion of weighting factors for intermediate frequencies for the new psophometer and new tolerances of measured weighting factors with respect to nominal values.

B. Increase of permissible induced electromotive forces beyond 430 volts.

C. The effect of transpositions in a telephone line on the psophometric electromotive force, appearing at the end of the line.

### 4. 2nd Study Group (*Protection Against Corrosion*)

The 2nd Study Group has heretofore distinguished means of protection against chemical action and those due to electrolytic corrosion. In the future, two documents will be issued: one dealing with corrosion generally, irrespective of the source, and one dealing specifically with corrosion caused by stray currents from electric traction systems.

The first-mentioned document was prepared in collaboration with the international bodies concerned with high-tension transmission lines, production and distribution of electric energy, electric railways, and gas production. It is entitled "Recommendations Concerning Protection of Underground Cables Against Corrosion, Edition 1949," and will be printed at an early date.

The second document has reached an advanced draft stage, and is expected to be ready for submission to the next plenary assembly in 1951.

### 5. 3rd Study Group (*Transmission; Lines*)

This study group is one of the largest and has constituent representatives of telephone administrations from no less than 20 countries. The magnitude of its work may be judged by the fact that the study programme for 1950 and 1951 comprises a total of 40 questions bearing on line, radio, and television transmission. Ten of these are new questions authorized by the Fifteenth Plenary Assembly, the remainder being old questions under continued study.

The forthcoming publication of the plenary proceedings will render a full account of the decisions reached by the Fifteenth Plenary Assembly. This article must needs be confined to some of the more important ones.

#### 5.1 INTERCONTINENTAL CIRCUITS

Approval was given to the recommendations of the 3rd Study Group, which were drawn up under three headings:

A. Overland circuits.

B. Overland circuits comprising one submarine cable link.

C. Radio links.



Provided that an overland circuit does not exceed 2500 kilometres (1554 miles), the existing recommendations shall be followed. Further studies will determine the limits applicable to circuits exceeding that length. In cases where a submarine link forms part of an overland circuit, it is left to the administrations concerned to discuss how far it will be economically possible to meet the limits recommended for overland circuits. The recommendations regarding radio links fall into two categories:

- A. Broad-band radio links using carrier frequencies greater than 30 megacycles per second (radio beams with optical or quasi-optical transmission).
- B. Circuits operating on frequencies less than 30 megacycles.

In the former case, a strongly directive antenna system can be used and the same frequency band adopted for different links. It is therefore recommended that efforts should be made to meet the Comité Consultatif International Téléphonique requirements for international overland circuits. When frequencies below 30 megacycles are used, consideration must be given to numerous factors that affect transmission, such as fading, atmospherics, and interference from other radio services. The recommendations with respect to preventive measures against such disturbing elements include the following directives. Radio links in the range below 30 megacycles should not be employed in cases where it is possible to use land lines or "optical-range" radio systems. The frequency band transmitted should not be less than 300 to 2600 cycles. Where, however, it is essential to obtain a large number of circuits in the high-frequency region (below 30 megacycles) it should be possible to arrange to use a narrower band by agreement between the interested parties in accordance with the merits of each case. Every effort should be made to increase the signal-to-noise ratio. Disturbing currents of sufficient magnitude to operate echo-

suppressors in circuits connected to a radio link should not be tolerated. All telephone circuits connected to a radio link should conform with the requirements for international circuits. The radio

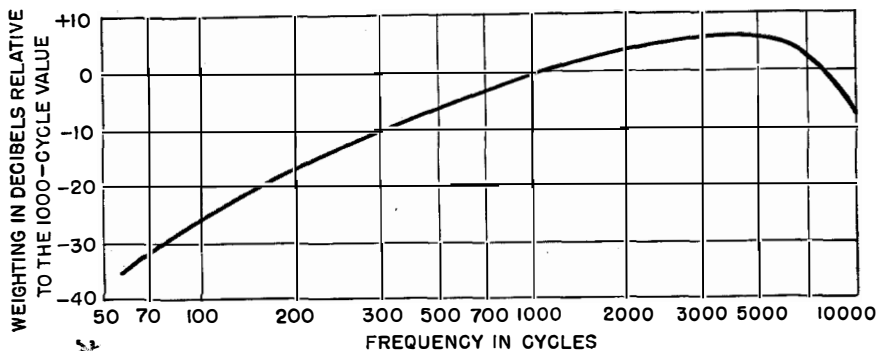

Figure 2—Variation with frequency of the overall equivalent of a complete normal programme circuit referred to the 1000-cycle value.

circuit should be equipped with reaction suppressors. If no automatic means are available, the technical operator should continuously check the transmission quality and make necessary adjustments. The radio circuit should include automatic gain control to compensate fading. The terminal equipment should be such that the radio circuit can be connected to any other circuit in the ordinary way. Any privacy equipment used should be of a design that does not affect the quality of the transmission.

## 5.2 COAXIAL CARRIER SYSTEMS

The existing specification (A-VI) contains the essential requirements that the constituent parts of a coaxial cable system should fulfil. The plenary assembly approved the definitions of the terms describing the parts that go to make up a coaxial carrier system. The recommendations applying to alarm signals, the advantages and disadvantages of alternating-current power supply over a coaxial cable and general practices in the latter respect were also adopted. Approval was given to the recommendation that it is redundant to maintain the limit on near-end crosstalk in a coaxial cable, recent tests having shown that it is always better than the far-end crosstalk. The far-end signal-to-crosstalk ratio measured on a repeater section between two coaxial pairs in the same cable should be at least 85 decibels (9.8 nepers) at any frequency effectively transmitted.

5.3 CARRIER WORKING ON SYMMETRICAL PAIRS

The general recommendations, adopted by the Fourteenth Plenary Assembly<sup>2</sup> (Montreux, 1946), remain unaltered. Since that time, the noise requirements for this class of circuit have been studied by the 3rd Study Group, who recommended that the total circuit noise on symmetrical cable pairs shall not exceed 2 millivolts (-7 decibels or -0.8 neper relative level) for circuits of a maximum length of 2500 kilometres (1554 miles).

5.4 BROADCAST CIRCUITS

Broadcasting organizations have for some years past advocated improvements of the cut-off frequency (6400 cycles) hitherto obtainable in circuits leased to them by telephone administrations. A new specification for broadcast circuits has now been approved. Henceforth, circuits effectively transmitting a band of 10,000 cycles (Figure 2) will be made available. For less exacting requirements, in a way related to the cost of the circuit, the use of circuits complying with the old specification remains authorized.

<sup>2</sup> P. E. Erikson, "Fundamental Toll-Switching Plan for Europe of the Comité Consultatif International Téléphonique," *Electrical Communication*, v. 26, pp. 9-16; March, 1949: see pp. 15 and 16.

Heretofore broadcast circuits have generally been carried in screened pairs or on the phantom of symmetrical pairs. In connection with the extended use of wide-band systems, a new method of providing broadcast channels has been approved. This method involves the use of 3 channels in a 12-channel group. It is recommended that such a circuit should occupy the band, either 64 to 76 kilocycles or 84 to 96 kilocycles (in the 60-to-108-kilocycle range), the latter arrangement being preferred.

5.5 NOISE

The measurement of noise on broadcast (music) circuits has presented many difficulties in the past, chiefly due to the defects of the old psophometer, dealt with earlier in this article. A weighting network to be used with the new psophometer, when programme circuits are to be tested, was provisionally adopted. The characteristic curve of this filter network is shown in Figure 3.

5.6 TELEVISION

Although considerable progress has been made in formulating recommendations regarding the technical requirements of successful transmission

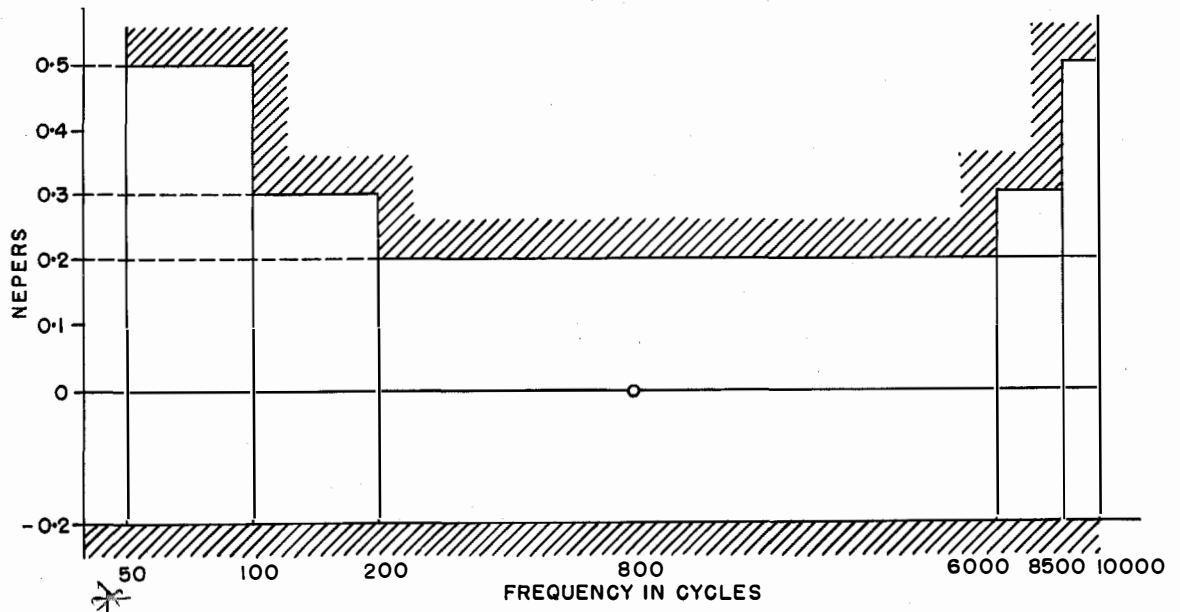

Figure 3—Characteristic curve of the psophometer filter network used for measurements of programme circuits.

*Note of Fig 2 and 3 should be reversed.*



of television over coaxial cables in Europe, two vital points have yet to be settled, namely:

- A. What are going to be the standard television signals to be transmitted?
- B. What distortion can be tolerated in the signals?

Coaxial cables specially designed for high-definition television have been made in some European countries, notably in Great Britain, but on the assumption that television organizations would wish to use the coaxial telephone cables now being installed in various countries, the information needed to answer the above-noted questions will have to be studied before final specifications can be prepared.

### 5.7 NOMENCLATURE

In the past the Comité Consultatif International Téléphonique published a rather-comprehensive list of the international circuits in Europe, including the main transmission characteristics of each circuit. The compilation of this document, which is known as "Nomenclature of Telephone Circuits," entailed a very considerable amount of work with attendant expense. It has now been decided to simplify this document, whilst retaining the information essential for the use of the various traffic departments in setting up their international connections.

Regarding the numbering of circuits, it was decided that for normal international circuits the names of the two terminal points in alphabetical order, followed by the number of the circuits, shall be used. For other types of circuits the following suffixes are to be provisionally adopted:

- P* = Private services (military, diplomatic, etc.).
- T* = Normal voice-frequency telegraph circuits.
- TP* = Private voice-frequency telegraph circuits.
- V* = Normal television circuits.
- VP* = Private television circuits.
- Z* = Circuits suitable for semi-automatic operation.

Broadcasting circuits:

- R* = One direction only.
- RR* = Both directions.

(Names of terminal points to follow direction of transmission.)

### 5.8 NEW QUESTIONS

Space does not permit the inclusion of the full text of these questions, which will appear in the forthcoming publication of the plenary proceedings. Some of the more important questions concern the preparation of general specifications for carrier systems on symmetrical cable pairs involving more than 24 channels, the absolute level at which the pilot frequency should be transmitted, and means for maintaining the relative power level at the points in the circuits where signal receivers are connected when two or more international circuits are switched in tandem. In co-operation with the 7th Study Group on tariffs, the 3rd Study Group will endeavour to assess the rates to be charged for the use of broadcast circuits of different bandwidths.

### 6. 4th Study Group (*Transmission; Apparatus*)

The limit of 40 decibels or 4.6 nepers, set for the overall reference equivalent of an international telephone circuit,<sup>3</sup> has been subject to discussions in the 4th Study Group, who recommended that it should never be exceeded and that it should include variations with time as well as tolerances in the efficiency of the telephone sets. The Fifteenth Plenary Assembly decided that, considering the influence of such variants, the limit could not be made absolute, but should be observed as nearly as possible.

For similar reasons the Assembly accepted a joint proposal by the 3rd and 4th Study Groups that the decision of the Fourteenth Plenary Assembly to include noise and cut-off impairments in overall planning of international connections should be rescinded. It was stated that the earlier recommendation had not been brought into practice, that it could not at present be implemented, and that no precise procedure could be specified. The Fifteenth Plenary Assembly, however, authorised a statement to be inserted in the proceedings to the effect that with the introduction at some future time of "performance rating" it might become unnecessary to specify a maximum limit for the overall reference equivalent of an international connection.

<sup>3</sup> See Figure 1 on page 9 of reference 2.

In the past, the transmission quality of a European telephone circuit has been judged in terms of its transmission reference equivalent. By this is meant the number of decibels or nepers that must be inserted in the transmission reference system, in order that the latter shall yield a telephone conversation that has the same loudness as the system to be evaluated. Before the second World War, a better method of quality rating was being considered for use in Europe. This method, which is known as "effective rating," is based on the so-called repetition rate, that is to say, the number of times a word or sentence has to be repeated in a given time of telephone conversation in service. Two telephone circuits, which give rise to equal repetition rates, are said to have equal effective rating. Many difficulties were encountered in developing this idea and therefore an alternative method of rating, based on articulation, is being studied by the Comité Consultatif International Téléphonique and is referred to as the "*A.E.N.* method," abbreviated from the French term, *Affaiblissement Equivalent pour la Nette*. No official translation has as yet been adopted, but it could be rendered "the method of articulation equivalent."

The application of *A.E.N.* (or articulation equivalent) has so far been considered only with reference to terminal losses. If terminal transmitting and receiving systems are joined by distortionless attenuation, and the attenuation is adjusted so that the sound articulation per cent has a standard fixed value (yet to be decided), the amount of attenuation thus introduced is a measure of the performance of the terminal systems. It is a statement of the line attenuation over which a standard grade of conversation can be sustained.

The *A.E.N.* of one system, as defined above, relative to another such system is the difference between the amounts of attenuation required in the two cases. In particular, one of the systems may be a special system used as an articulation reference system.

Arrangements have been made to carry out a series of closely controlled experiments in the laboratory of the Comité Consultatif International Téléphonique at Geneva to test whether *A.E.N.* values of definite significance can be attached to different systems.

The design of an improved psophometer has been referred to earlier in connection with its uses for interference measurements. The specification was prepared by the 1st and 4th Study Groups.

The new psophometer is designed for use at any point of an international line and therein differs from the old psophometer which was designed for use at the receiver terminals of the subscriber's instrument, although used (by general consent) at other points of a circuit. It therefore meets the main requirement in service, namely the measurement of line noise. The 4th Study Group is, however, much concerned with line noise at the subscriber's receiver and a new question for study has therefore been set up to determine how such observations should be made.

It was announced at the Fifteenth Plenary Assembly that the laboratory had been moved from Paris to Geneva. Plans were made (and since carried out) for the 4th Study Group to meet in Geneva in October 1949 to inspect the laboratory installations and accept (on the part of the Comité Consultatif International Téléphonique) the new system to be used for articulation tests (*A.R.A.E.N.*)<sup>4</sup> that has been lent by the British Post Office.

## 6.1 NEW QUESTIONS

In addition to continued studies of 14 questions on its agenda, the 4th Study Group has been authorized to consider several new ones. The subject matter of the new work includes the search for new methods of measuring crosstalk and room noise and, if feasible, a standard source of reference room noise for use in telephometric measurements. It is also desirable to establish a method of passing from the reference equivalent to that of performance rating, when specifying transmission quality. Information is also being collected concerning the realisation of artificial voice-ear apparatus.

## 7. 5th Study Group (Co-ordination: Wire-Radio)

Problems arising from the interworking of radio circuits and land lines are dealt with by the

<sup>4</sup> Appareil de Référence pour les *A.E.N.*

5th Study Group. The questions, authorized for study by the Fourteenth Plenary Assembly, included:

- A. Secrecy devices.
- B. Reaction suppressors.
- C. Control devices for carrier equipment in ship-to-shore telephone service.
- D. Links between mobile radio stations and international telephone networks.

### 7.1 SECRECY DEVICES

In approving the study of such devices, the Fourteenth Plenary Assembly unanimously decided that the term secrecy should be interpreted to mean relative secrecy, the object being to give protection against the inquisitive amateur rather than against the professional. This can be accomplished to a degree by using the systems described in the published proceedings of the Fourteenth Plenary Assembly.<sup>5</sup> The Fifteenth Plenary Assembly approved the recommendation of the 5th Study Group that these descriptions should be included in Volume III of the Paris plenary proceedings as guiding information for prospective users.

### 7.2 REACTION SUPPRESSORS

Various types of reaction-suppressor systems, at present in use or under development, were classified and included in the Montreux proceedings.<sup>6</sup> The Fifteenth Plenary Assembly adopted this classification and authorized the insertion of the descriptive text in Volume III of the Paris proceedings.

The essential characteristics of reaction suppressors will be subject to further study with a view to ultimate standardization.

### 7.3 CONTROL OF CARRIER EQUIPMENT IN SHIP-TO-SHORE TELEPHONE SERVICE

The methods, developed by the American Telephone and Telegraph Company, to control

<sup>5</sup> "C.C.I.F. Plenary Assembly, Montreux, 1946," Volume I, p. 334 in the French edition; p. 310 in the English edition.

<sup>6</sup> "C.C.I.F. Plenary Assembly, Montreux, 1946," Volume I, p. 339 in the French edition; p. 316 in the English edition.

operating time and release time in devices operated by speech currents or by carrier wave in ship-to-shore radiotelephone services, are described in the Montreux proceedings.<sup>7</sup> The Fifteenth Plenary Assembly adopted this text with one amendment. The table on page 342 of the French text (page 319 of the English text) will be replaced by a statement to the effect that the net operating time necessary to obtain a tolerable minimum of transmission quality should not be greater than 25 milliseconds for a test tone amplitude of -30 decibels and 15 milliseconds for an amplitude of -20 decibels with reference to the amplitude that produces 100-per-cent modulation.

### 7.4 LINKS BETWEEN MOBILE RADIO STATIONS AND INTERNATIONAL TELEPHONE NETWORKS

The 5th Study Group reported that the state of development of systems, suitable for international connections, has not advanced sufficiently for immediate adoption. Certain requirements for satisfactory operation have however been formulated and will form the basis of continued studies of this problem. The scope of these requirements includes the necessity of adopting 2-wire termination at the switchboard for interconnection to the land circuit, speech levels in and out of the radio circuit to co-ordinate with the conditions of the international land-line circuits, the influence of the attenuation-frequency characteristic of the radio circuit on the transmission quality of the overall connection, and the proper suppression of noise from the radio circuit to prevent false operation of echo suppressors and similar devices in the land lines.

### 7.5 NEW QUESTION

In co-operation with the Comité Consultatif International de Radio, the 5th Study Group will examine into the operating conditions to be recommended for telephonic communication between mobile radio stations (road vehicles, aeroplanes, and ships) and international telephone lines.

<sup>7</sup> "C.C.I.F. Plenary Assembly, Montreux, 1946," Volume I, p. 340 in the French edition; p. 317 in the English edition.

### **8. 6th and 7th Study Groups (Operating and Tariffs)**

The 6th Study Group deals with operating questions and the 7th Study Group with those concerning international tariffs. The two subjects are closely interlinked in many respects and for this reason the main recommendations that came before the Fifteenth Plenary Assembly are here recorded under a common heading. It should be mentioned here that the Administrative Conference of the International Telecommunication Union held a meeting in Paris from May to August in 1949 with the object of revising the international telephone and telegraph regulations (Madrid 1932 and Cairo 1938). The decisions, reached by that body which acted with plenary powers from the International Telecommunication Union, governed the work of the 6th and 7th Study Groups and are reflected in the recommendations approved by the Fifteenth Plenary Assembly.

The 6th Study Group accordingly revised its recommendations on operating procedure to harmonise with the new telephone regulations (Paris 1949). Most of the changes were of a minor nature, but there was one important change made to the effect that, in the future, distress calls would be given absolute priority without question.

In drawing up the various recommendations and instructions to operators, the general trend was to allow scope for improved and more rapid methods to be used in the future. The agreement reached in Stockholm (1948) as regards calling in an assistance operator at the incoming end of the international line and the proposals for handling *préavis* calls were approved by the Fifteenth Plenary Assembly on the understanding that these recommendations should be specifically marked as being provisional.

The 8th Study Group had asked whether, in the event of it being impossible to summon an assistance operator at the incoming end on a transit connection, the signal should be employed to call an operator in the transit country. The 6th Study Group decided to suppress this question with a note that it could be re-introduced later, if the result of trials made it appear necessary.

It was agreed that administrations should, as far as possible, prepare and distribute propaganda booklets giving information concerning the international facilities available. A vocabulary and glossary of terms are to be prepared for this purpose by a special sub-commission.

The 7th Study Group was not able to adopt all of the recommendations, previously made at Stockholm (1948), owing to delay in the provision of new high-speed cables. The full reduction recommended by the Tariff Revision Committee could not be implemented immediately, but for the present a case was made out for reduced charges, preliminary to carrying out the full reduction. At the suggestion of the delegation of the Union of Soviet Socialist Republics this recommendation was worded so as to emphasize the full sovereign rights of each country to make their own charges.

The same delegation proposed that the new directive for the revision of Avis No. 42, "International Telephone Charges," should be given further study. The delegations of France, Great Britain, and Switzerland urged the necessity of establishing charges for new types of circuits. The Assembly eventually decided to modify slightly the existing charges with a consequent reduction in the charges for the longer circuits.

The charges to be applied to telephone-radio links in international service were also discussed. For normal-quality radio transmission, it was decided to apply a tariff 1.25 times the ordinary rate and a surtax corresponding to 10 minutes conversation during busy-hour conditions. For high-quality radio circuits, 3 times the ordinary rate shall apply with a surtax equivalent to 24 minutes.

The telephone regulations, which previously applied to Europe only, were extended to cover the countries surrounding the Mediterranean. A recommendation was made concerning the use of international telephone circuits over power circuits, principally with the view to prevent their use by unauthorised persons. Various definitions (in French) were agreed and administrations interested were asked to communicate corresponding terms in their own languages.

It was decided that for the present it would not be advisable to re-introduce the cheap night

rates formerly available in Europe. A point of minor interest is that it is now possible to book a call to two numbers; if the first is not obtainable, the call is transferred to the second number. With regard to the setting up of broadcast or music circuits, the broadcasting organisations previously had to pay for 15 minutes for the so-called preparatory period. This was altered so that the payment would cover only the actual time utilised.

In order that the administrations should be able to reimburse themselves for the additional work necessary in preparing broadcast circuits for a particular transmission, a scale of additional charges was agreed on.

With regard to transit circuits, it was decided that the transit country should derive its revenue from the actual traffic over the circuit and that no minimum rental or payment was necessary.

### 8.1 NEW QUESTIONS

In addition to current questions on their agenda, the 6th and 7th Study Groups are arranging to collect and co-ordinate data concerning certain practices, adopted by various administrations and operating companies, in handling intercontinental traffic. More specifically, these practices relate to the classification and priority rating of various calls; arrangements for emergency circuits, and the rates charged when the latter are brought into service. Information is also to be gathered concerning the time limit, if any, imposed on the validity of a booked call. It is also desirable to know what rates are applied in each country with respect to report charges and charges for various classes of calls. Given the rate charged for the use of a direct intercontinental circuit, it is of interest to establish relations between that rate and the rates to be charged: (A) when two intercontinental circuits are used to reach a desired point and (B) when the circuit is extended by a continental network to reach the destination.

After consideration of the information obtained on the above-mentioned points, the 6th and 7th Study Groups will consider:

A. Whether a documentation on this subject should be issued either in the form of information or in the form of recommendations?

B. Whether any recommendations for changes (in the Atlantic City Convention) of the provisions that relate to the intercontinental telephone services are desirable?

C. After replying to (A) and (B), whether it is desirable to recommend an additional set of regulations annexed to the International Telecommunication Convention and applying to intercontinental telephone services?

### 9. 8th Study Group (Signalling and Switching)

The Fourteenth Plenary Assembly authorized the study of 16 questions relating to signalling and switching in the international service. Some of these questions are of a general nature, such as providing means of avoiding interference between voice-frequency systems, protection of signal receivers by guard circuits, international standardization of subscribers' dials, and switching of international circuits on a 4-wire basis.

The 8th Study Group acts as an advisory body on signalling and switching as applied to the European Toll Switching Plan,<sup>8,9</sup> and some of the questions authorized at Montreux were prompted by the projected use of high-speed transmission circuits in the international telephone service. Many new problems have to be solved in connection with the application of the new circuit technique.

The proposed introduction of semi-automatic switching, outlined below in Section 11, involves signalling and switching features that have been studied by the 8th Study Group, under whose direction the commission works.

At the Fourteenth Plenary Assembly a sub-commission, composed of members of the 6th and 8th Study Groups, was appointed to deal with rapid operating methods and their application to the international service. On July 18-19, 1949 members of this sub-commission and of the 8th Study Group met for the purpose of editing the text of its recommendations, which were approved by the Fifteenth Plenary Assembly.

The revision of the directives, governing manual operation of international circuits, as approved for the European Toll Switching Plan by the Fourteenth Plenary Assembly, was partly

<sup>8</sup>E. P. G. Wright, "Modernization of International Telephone Service, and Its Reaction on National Telephone Systems," *Electrical Communication*, v. 24, pp. 436-467; December, 1947; see page 436.

<sup>9</sup>See page 9 of reference 2.

due to the application of the new telephone regulations, adopted by the administrative conference in Paris (1949). It modifies to some extent the definitions of normal, auxiliary, and emergency routes. The old diagram, showing a typical international connection, was corrected in that the terminals of the two international circuits shown are so designated instead of being referred to as international transit centres (in the old diagram).

The recommendations on rapid operating methods in general were adopted with minor modifications.

9.1 NEW QUESTIONS

Among the more important questions to be studied during 1950 and 1951 may be mentioned the case where automatic-signalling frequencies are to be used in connection with manually operated international circuits. The questions of signal codes and tolerances of the constituent

signal elements will be pursued. The introduction of semi-automatic switching in the international service calls for a revision of the existing schedule of group circuit capacities,<sup>10</sup> which apply to manual operation. In some countries, international circuits terminate in several international exchanges. The question is: what facilities should an operator in one of these exchanges have to set up a call by using an international circuit terminated at another international exchange? Directives for the maintenance of signalling equipment will also have to be drawn up.

10. European Toll Switching Plan

An earlier article in this journal<sup>2</sup> contains particulars of the fundamental toll switching plan for Europe approved by the Fourteenth Plenary Assembly. The mixed commission (of the 3rd, 4th, and 6th Study Groups) responsible for the detailed planning has since brought this plan

<sup>10</sup> See page 10 of reference 2.

TABLE 1  
EUROPEAN TOLL SWITCHING PLAN  
Estimated Number of Circuits Required by April 1952

	Austria	Belgium	Bulgaria	Czechoslovakia	Denmark	Finland	France	Germany	Great Britain	Greece	Hungary	Italy	Luxembourg	Netherlands	Norway	Poland	Portugal	Rumania	Spain	Sweden	Switzerland	Turkey	U.S.S.R.
Austria	—																						
Belgium	12	—																					
Bulgaria	12	0	—																				
Czechoslovakia	24	12	12	—																			
Denmark	0	12	0	12	—																		
Finland	0	0	0	0	12	—																	
France	24	300*	12	24	12	0	—	60	—														
Germany	36	36	—	12	12	—	—	—	—														
Great Britain	12	72	0	12	24	0	156†	72	—														
Greece	0	0	12	0	0	0	12	0	0	—													
Hungary	24	12	12	24	0	0	12	12	12	12	—												
Italy	24	12	12	12	0	0	84	48	36	12	12	—											
Luxembourg	0	—	0	0	0	0	—	12	0	0	0	0	—										
Netherlands	12	144	0	12	12	0	60	48	96	0	12	12	12	—									
Norway	0	0	0	12	48	0	12	24	24	0	0	0	0	12	—								
Poland	24	12	12	24	12	0	12	12	12	0	12	12	0	12	12	—							
Portugal	0	0	0	0	0	0	12	0	12	0	0	0	0	0	0	0	—						
Rumania	12	—	24	24	0	0	12	12	12	0	24	12	0	0	0	12	0	—					
Spain	0	0	0	0	0	0	36	12	12	0	0	12	0	0	0	24	0	0	—				
Sweden	12	12	0	12	120	72	12	36	24	0	0	12	0	12	120	12	0	0	0	—			
Switzerland	36	36	12	12	12	0	96‡	36	60	0	12	84	12	36	0	12	12	12	12	12	12	—	
Turkey	0	0	24	12	0	0	12	0	0	12	12	0	0	0	0	0	0	12	0	0	0	0	—
U.S.S.R.	12	12	24	24	0	—	12	12	12	0	12	—	0	12	0	12	0	12	0	12	0	0	—
Yugoslavia	12	0	24	24	0	0	12	12	12	12	24	24	0	0	0	12	0	12	0	0	12	12	12

\* Belgium-France: 180 Brussels-Paris and 120 Brussels-Lille.  
 † France-Great Britain: 132 London-Paris and 24 Lille-London.  
 ‡ France-Switzerland: 96 Paris-Switzerland and 48 short-haul circuits.

up to date and obtained the approval of the amendments from the Fifteenth Plenary Assembly. Since the first drafting of the plan, administrations have had occasion to modify their estimates of the number of international circuits required in 1952. Table 3 in the above-mentioned article, which shows the original estimates, will now be replaced by Table 1 in this article. The Plenary Assembly considered that the countries in Africa and in Asia bordering on the Mediterranean should properly be included in the European Toll Switching Plan. Accordingly the name of the plan will be changed by incorporating the words "and the Mediterranean Basin" in the title. All Mediterranean countries will be invited to table their proposals for inter-continental circuits at the forthcoming meetings of the mixed commission. Many of these circuits will comprise radio relay links or submarine cables with submerged repeaters. In 1948, the International Telecommunication Union published a map of international broadcasting circuits in all of the European countries with the exception of Germany. The Allied Control Commission in Western Germany has since released information on broadcasting circuits now available in that territory. This information was presented to the mixed commission by accredited representatives of the Control Commission.

### ***11. Commission for Semi-Automatic Field Trials on International Circuits***

At its meeting in Scheveningen (1949), the commission agreed on a general specification that will apply to the field trials with semi-automatic operation on selected international circuits. As soon as the equipment required is available these trials will be made on two international networks:

- A. A West European system, using circuits between London, Amsterdam, Brussels, Paris, and Zürich.
- B. A Scandinavian system, involving the cities of Copenhagen, Oslo, and Stockholm.

The object of the trials is to ascertain the most suitable system of signalling and switching from a technical as well as an operating point of view. The aim is a rapid operating method, in which the operator at the outward international centre sets up an international circuit without the

assistance of another operator at the inward international exchange.

Specifically, there are three points on which it is hoped to get reliable information:

- A. The relative merits of a proposed signalling system, using two frequencies (transmitted simultaneously or separately) and a single-frequency system.
- B. Proportion of successful attempts on the part of the outward international operator to set up a circuit without the assistance of a second operator.
- C. Operating method to be used for *préavis* calls when semi-automatic switching alone is used.

Briefly, the principles applicable to the routing of calls during the trials are based on three assumptions:

- A. All international transit centres are connected by "final" routes, but not necessarily by direct routes.
- B. Countries, in which no international transit centre exists, have at least one "final" choice route.
- C. All other international routes are to be regarded as consisting of "high-usage" circuits.

It is evident that the number of international circuits available for the trials will be too small to test the normal conditions under which overflow traffic is diverted to "final" routes. It is, however, desirable that the equipment used in the trials should be so designed as to verify the principles of operation by artificially increasing the traffic on some direct routes during periods of light traffic.

The general specification, which was approved by the Fifteenth Plenary Assembly, is drawn up in considerable detail as regards the requirements imposed on the equipments to be used for the two systems under test. It is understood that, in the Scandinavian trials, only the two-frequency signalling system will be tried.

### ***12. Maintenance Sub-Committee***

Officially, a formal meeting of the Maintenance Sub-Committee was not called for at Paris, but a number of meetings were held under the chairmanship of Mr. Visser (Netherlands Posts, Telegraphs, and Telephones) to review the results of the special tests mentioned below, and actually the committee did also review certain matters proper to the normal Maintenance Sub-Committee.



The sub-committee examined the results of the special tests, made to determine the variation of overall equivalent with time on international circuits, which had been decided upon at Scheveningen. It will be recalled that the 8th Study Group had become very interested in the variation of equivalent of international circuits in determining specifications for signalling receivers, particularly for tandem working. As very little data were available as to the extent of this variation on international circuits, it was decided at Scheveningen that some tests should be carried out before the Paris meeting to obtain some idea of the extent of the variation.

In Paris each country concerned produced their series of results, which were combined and an overall mean and standard deviation figure obtained for all the routes under test. At a frequency of 800 cycles the mean of all the circuits was 0.91 neper<sup>11</sup> (7.9 decibels) with a standard deviation of 0.21 neper (1.82 decibels). This figure, however, excluded readings that showed a variation from the nominal equivalent of more than  $\pm 0.5$  neper (4.34 decibels) and indicated that the circuits were varying to a greater extent than was originally thought. The committee discussed the possible causes of these variations and it was noted that in some instances there was a very close correlation between the variations of the go and return of the circuit. In many instances, however, it was considered that the variations were due to incipient faults on circuits, and various remedial measures were suggested.

Should the 3rd and 8th Study Groups consider the above figures not sufficiently good for semi-automatic operation, the sub-commission believed that an improvement could be obtained by the following means:

- A. Systematic check of all the equipment in a repeater station.
- B. Systematic check of individual circuits.
- C. Increase in the frequency of periodical maintenance tests.

These recommendations are dependent on an increase in the maintenance personnel.

<sup>11</sup> An international circuit, when lined up for service, should by general agreement have an equivalent of 0.8 neper (7 decibels).

The sub-commission emphasized the great importance of the punctual execution of the tests laid down in the maintenance schedules.

The committee considered, however, that the period of the test, which was only five weeks, was not sufficiently long to enable stable statistics to be derived from the data obtained, and proposed that a further series of tests should be carried out for a period of five months, commencing in September, 1949.

The committee confirmed its proposals, made at Scheveningen, for modifications in the publication "Nomenclature des circuits téléphoniques internationaux," published by the Berne Bureau. These modifications, which consist mainly in deleting the complicated technical detail from the list of circuits, should assist materially in the rapid preparation of the information and should not detract from the normal uses to which the publication is put.

Finally, the committee proposed that a new question should be put forward for study concerning the maintenance of international wide-band carrier systems and 12-circuit groups. This new question was considered desirable as it was foreseen that the European wideband network would gradually become more and more complicated and that very long 12-circuit groups would be routed over it. The first instructions on international 12-circuit-group maintenance were only considered by the Comité Consultatif International Téléphonique in 1946 and, so far, the procedure has been successful, though it should be regarded as more of a trial than a final instruction. Consequently, the Maintenance Sub-Committee consider that the new question would enable the past procedure to be reviewed in the light of experience obtained to date and further recommendations made for the future.

### ***13. Commission for Literary and Graphical Symbols***

The Symbols Committee recommended that, whereas standard letter symbols should be used where possible, it should be permissible to substitute a lower- for an upper-case letter of the same alphabet and vice versa and to replace cursive letters or letters of the Greek alphabet by the corresponding Roman letters where no confusion is likely to arise. This recommendation was

adopted and will facilitate the preparation of typewritten reports.

Of particular interest is the recommendation that:

*A* represents the overall attenuation.

*B* represents the overall phase change.

$\gamma$  or  $p$  represents the propagation coefficient.

$\alpha$  or  $a$  represents the attenuation coefficient.

$\beta$  or  $b$  represents the phase coefficient.

$\Gamma$  or  $P$  represents the overall propagation.

### 13.1 NEW QUESTIONS

Although a considerable amount of work has been done to produce suitable symbols for use in international telephony, much remains to be done to keep pace with the advancement of the technique. Many concepts are common to allied arts (radio, acoustics, etc.), and, before a symbol can be recommended for international use, it is necessary to confer with other international organizations, engaged in similar work.

The working programme of the Comité Consultatif International Téléphonique for 1950 and 1951 includes definitions and symbols, relating

to the characteristics of electronic tubes, used in telecommunication. This work will be done in collaboration with the Comité Consultatif International Télégraphique and the Comité Consultatif International de Radio. Definitions of the principal acoustic terms will be formulated in consultation with the International Standardization Organization and a list of symbols prepared. Standardization of circuit diagrams, involving the sequential operation of relays in automatic switching will be undertaken. Last, but not least, symbols will be required for the waveguide technique.

### 14. Publication

The Proceedings of the Fifteenth Plenary Assembly of the Comité Consultatif International Téléphonique are to be published by the General Secretariat of the International Telecommunication Union, Geneva, Switzerland. The French edition, now available, comprises five volumes of Proceedings and two supplementary volumes, containing documentary information pertaining to Volumes III and IV (Transmission).

# Industrial Television System

By R. W. SANDERS

*Capehart-Farnsworth Corporation, Fort Wayne, Indiana*

**A** WIRE-LINE industrial television system was designed for power plants where the boiler-water level must be monitored from the control room. After 50 of these units had been manufactured, it was apparent that other industries had need for similar devices and a more universal type of industrial television equipment was developed.

• • •

industrial equipment. Continuous service-free operation results from using a minimum of tubes. Actually, the complete system requires only 15 standard receiving tubes, the cathode-ray picture tube, and the image dissector. All tubes are operated well within their ratings.

Figure 1 shows an actual picture of a test chart taken from the monitor (receiver) screen. Figure 2 shows the complete equipment, which

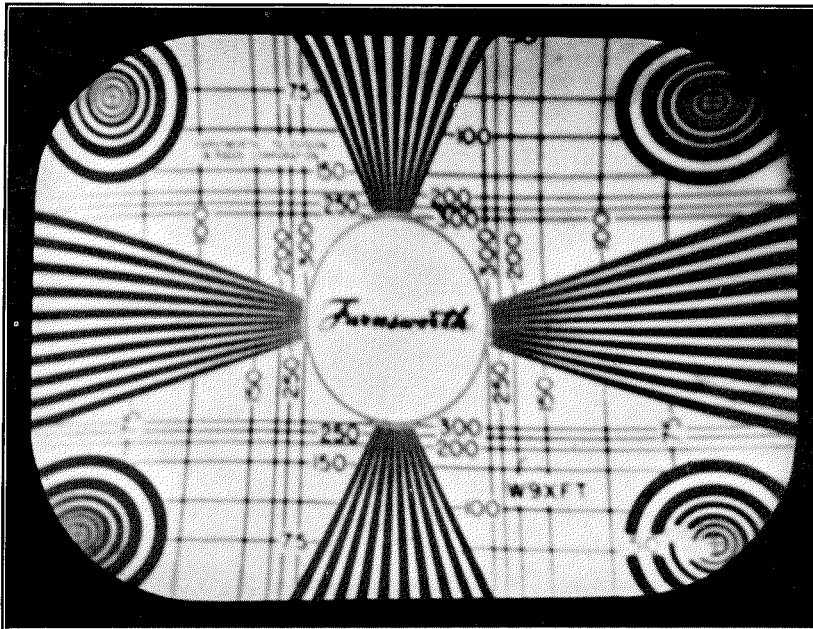

Figure 1—Test chart photographed from the cathode-ray-tube screen of the receiver.

## 1. General

The *U-300* Utiliscope employs the standard 4:3 aspect ratio and has a resolution of 300 lines horizontally and vertically. An image-dissector pickup tube is used to convert light variations into electrical waves. Its instantaneous characteristic (not a storage type) and high video-frequency output permit foolproof and extremely simple operation, factors of major importance in

consists of a camera unit, power unit, monitor or receiving unit, and connecting cables.

The camera unit is placed near the object to be viewed and is connected through a multiple-conductor cable to its power supply, which may be as far as 25 feet away from the camera. Three coaxial cables go to the monitor, which may be 1000 feet from the camera. These three cables carry the video-frequency signals and the

horizontal and vertical synchronizing pulses to the monitor. A single cable could be used at the expense of more complicated equipment, with its attendant service and maintenance problems.

High-voltage pulses from the beam relaxor are rectified by the two *8016* tubes in parallel to supply the multiplier and cathode voltages to the dissector.

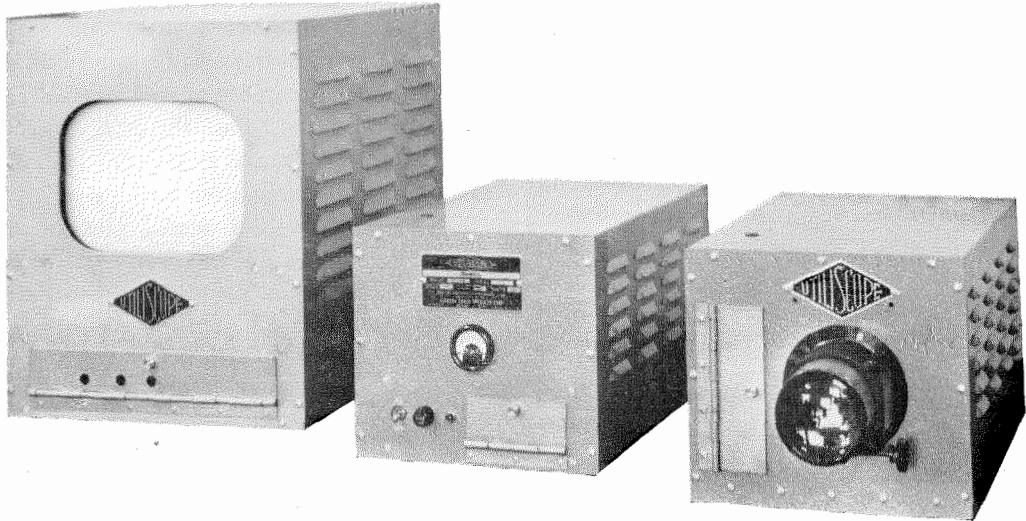

Figure 2—The Utiliscope system uses only three pieces of equipment, a monitor (receiver), camera power supply, and camera pickup unit.

## 2. Schematic Arrangement

A block diagram of the complete equipment is given in Figure 3. The image is focussed optically on the cathode of the image dissector in the camera. Horizontal- and vertical-deflection voltages and direct-current power for the various tubes are obtained from the power unit. The video-frequency signal from the dissector passes to the automatic black-level setter, which also receives blanking pulses from the power unit. The composite signal is then amplified by the *6AC7*, and after passing through the cathode-follower goes to the monitor over a coaxial line.

In the power unit, the *6SN7* oscillator-amplifier supplies vertical-deflection power to the camera unit and vertical synchronizing pulses through the *6J5* cathode-follower to the monitor. It also feeds vertical blanking pulses to the second *6SN7*. The *6L6* beam relaxor supplies horizontal scanning power to the deflection coils and pulses to the *6SN7*, which mixes, clips, and shapes the horizontal and vertical blanking pulses for the dissector. The beam relaxor also supplies horizontal synchronizing pulses to the monitor.

In the monitor, the vertical-deflection synchronizing pulses trigger the *6SN7*, which supplies vertical-deflection power to the cathode-ray tube. The horizontal-deflection synchronizing pulses from the power unit are amplified by the *6SN7* to synchronize the *6L6* beam relaxor, which supplies horizontal-deflection power to the cathode-ray tube as well as high-voltage pulses to the pair of *8016* rectifiers to produce approximately 8000 volts for the picture-tube anode. The video-frequency signal from the camera is amplified by the *5693* and *6AC7* tubes before being applied to the grid of the picture tube. A *1N34* is used as the direct-current restorer.

## 3. Camera Unit

### 3.1 OPTICAL SYSTEM

A lens focuses the object to be viewed on the translucent cathode of the dissector pickup tube. This lens is of 90-millimeter focal length and has a speed of  $f/1.4$ . The lens is coated to be non-reflecting for light of 7000 angstrom units. The mounting uses rack-and-pinion gearing for focus

adjustment, which is effective for objects 20 inches or farther from the lens. A motor can be coupled to the pinion gear for remotely focussing the camera. The angle of coverage for a 2-inch horizontal scan is approximately 27 degrees.

3.2 IMAGE DISSECTOR

The image dissector, shown in Figure 4, is a new type that uses a translucent instead of a solid cathode. One of its main advantages is that a fast wide-angle lens may be used. Also, under

sensitivity is in the near-infrared portion of the spectrum.

The cathode is at the end of the tube and directly behind it are five rings. Immediately behind the five rings is the nickel wall coating or the anode. Each of these rings is connected to a terminal on the front of the tube. There is an over-all voltage between cathode and anode of approximately 400 volts. The five rings are connected between the cathode and anode and have a differential of 75 volts between adjacent pairs. The purpose of these rings is to improve

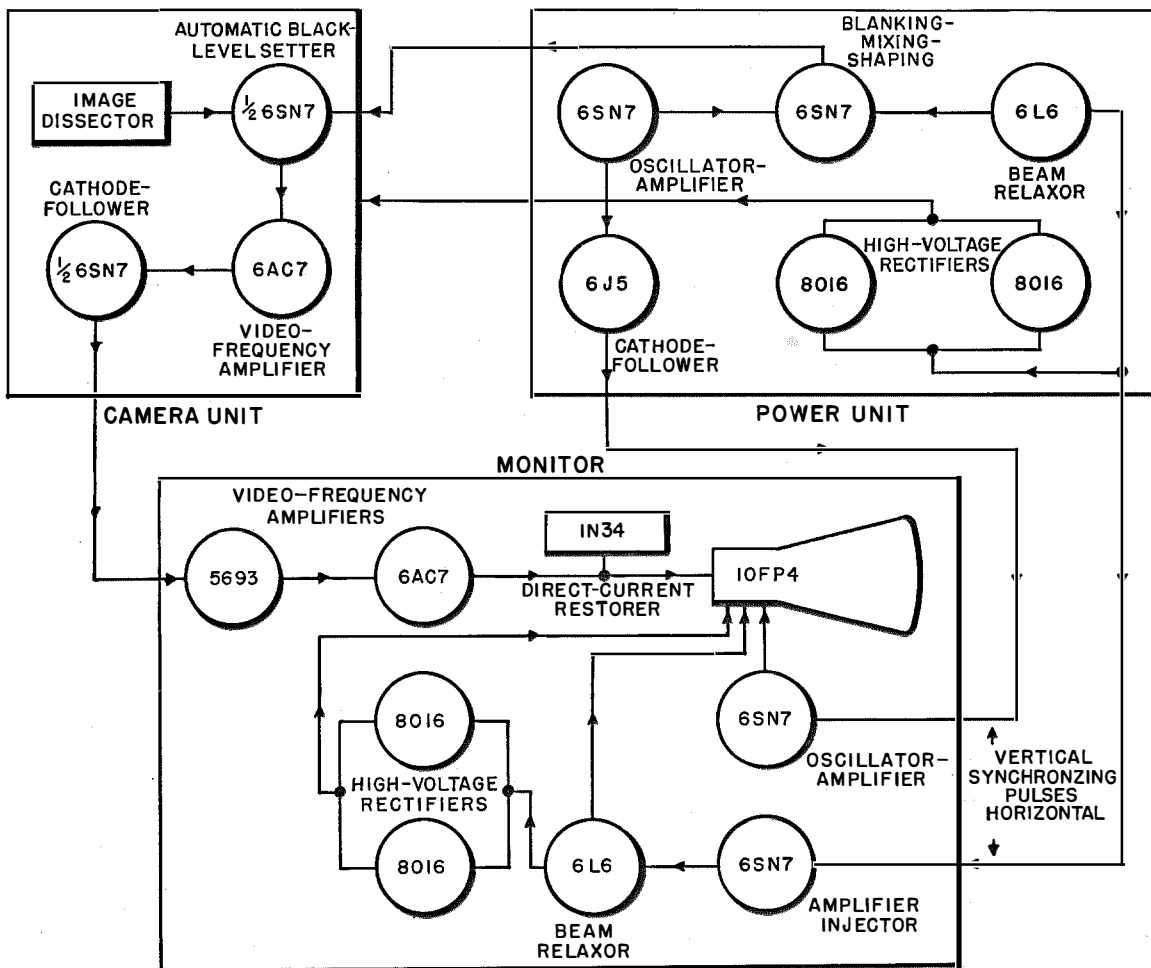

Figure 3—Block diagram of Utiliscope.

certain conditions, light reflected from the wall coating to the cathode of the solid-cathode type would degrade the picture contrast. This is eliminated with the translucent cathode. Figure 5 shows a typical response curve; the peak

the field in the vicinity of the cathode and decrease the amount of S distortion.

On exposure to light, an electron image extends outward from the back of the translucent cathode like bristles in a brush, usually diverging

from the cathode. It is possible to expand the size of this electron image up to  $2\frac{1}{2}$  times by employing a suitable magnetic focussing field. The extended electron image is focussed by a longitudinal field parallel to the axis of the dissector onto the multiplier housing, which has a plate having a small aperture at the center. The image is deflected across the aperture, horizontally and vertically, by rectilinear saw-toothed magnetic fields arranged at right angles to one

current after passing through the aperture strikes the plate of the first multiplier stage. The multiplier plates are coated with a secondary-emissive material and each stage has a gain of 3 or 4 when the voltage per stage is 200 volts. Total gain of the 11-stage multiplier is approximately 500,000. Silver-magnesium coatings are used for the secondary-emission surfaces instead of the cesium-oxide-silver used in the solid-cathode type dissector in order to provide better uniformity in

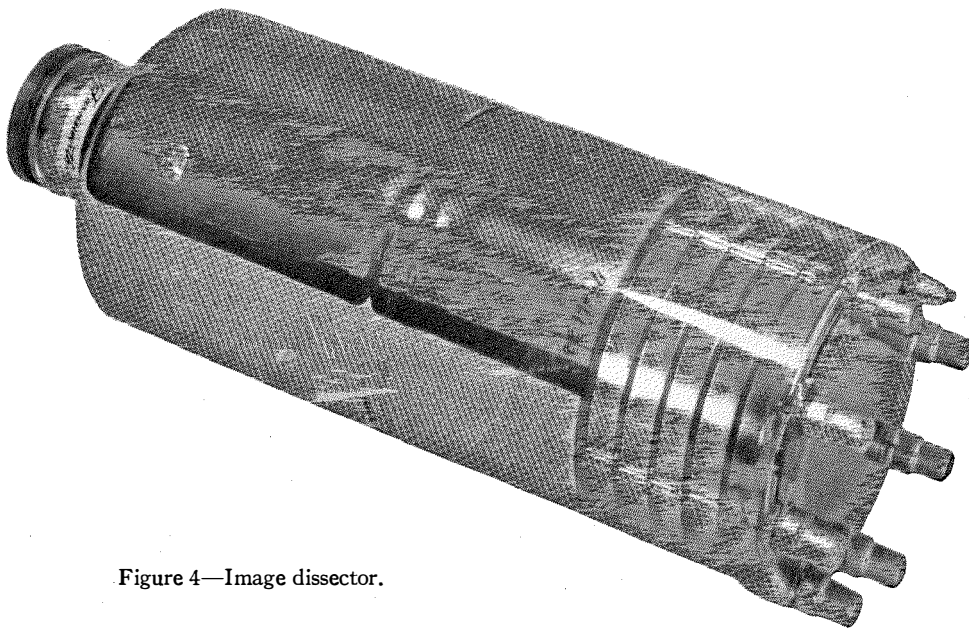

Figure 4—Image dissector.

another. The electrons passing through the aperture fall on the input of an 11-stage secondary-emission multiplier.

The aperture is in most cases a 0.030-inch square. Its size determines the amount of detail in the picture; the higher the definition desired, the smaller will be the aperture.

As the extended image is scanned across the aperture, the space current entering the multiplier is proportional at every instant to the part of the extended-image current density at which the aperture is looking. The aperture current is proportional to the area of the aperture, illumination on the cathode, and photosensitivity of the cathode. The photosensitivity is approximately 20 microamperes per lumen. This varying

multiplier performance from tube to tube. The problem of cesium shorts in the multiplier is also eliminated.

The signal-to-noise ratio varies as the square root of the aperture area while the resolution is inversely proportional to the aperture size. Thus, for a given illumination, a compromise must be made between noise and resolution. If definition of the order of 500 lines is desired, the picture may be noisy unless a high light intensity is used.

The 11-stage secondary-emission multiplier is operated with 180 volts across each stage. Approximately 2000 volts are applied to a resistive voltage divider from which the stage voltages are obtained. By varying the voltage between

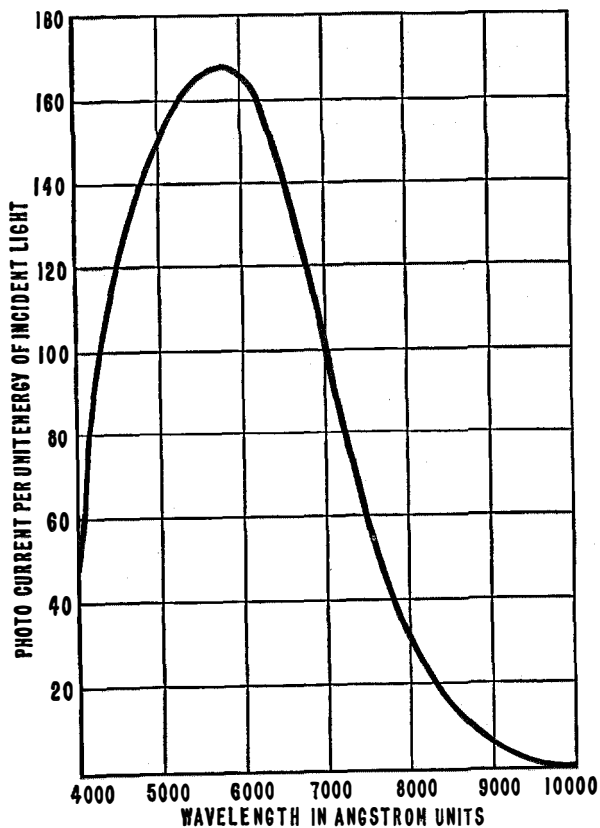

Figure 5—Spectral response curve of the translucent-cathode image dissector.

cathode and anode, the size (width and height) of the picture is controlled.

Overloading of the multiplier occurs only in the last two or three stages. To permit wide ranges of illumination to be tolerated, the voltage on the sixth stage is adjustable, providing a convenient gain control.

The image dissector is of the instantaneous (not storage) type and requires no shading compensation. It has no filament or heater to limit its life. Being of sturdy mechanical structure, it is not subject to microphonic troubles. With reasonable light intensities, an output video-frequency signal of the order of  $\frac{1}{2}$  volt may be obtained. The gamma of the tube is unity and it has linear input-output characteristics over an extremely large operating range.

### 3.3 DISSECTOR-COIL SYSTEM

Figure 6 is a photograph of the dissector-coil assembly, which combines the horizontal-deflection coil, vertical-deflection coil, and focus coil. It is a complete plug-in assembly. *S* distortion is minimized consistent with simple construction. An electron-image magnification of about 1.5 times is obtained.

The horizontal-deflection coil is the inner coil and is approximately 9 inches long. For vertical deflection, a toroidal coil approximately 1 inch long is wound over an iron form. This coil fits snugly on the horizontal-deflection coil. These two coils are electrically at a 90-degree angle with respect to each other. The focus coil is quasi-layer wound and sets directly over the dissector cathode. The coil assembly is supported by three studs on the front of the focus coil, which extend through slots in the front plate of the coil housing and are secured with wing nuts. The coil assembly can be

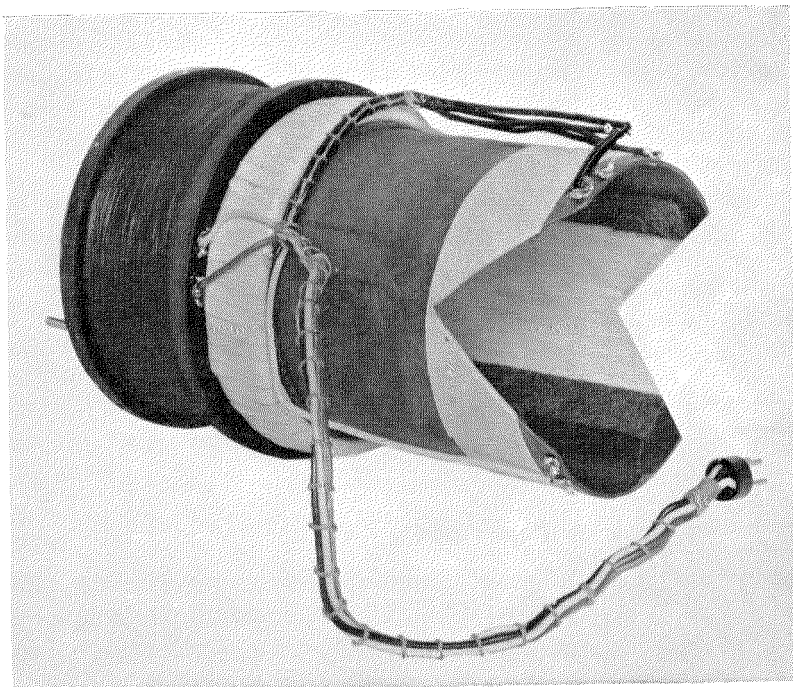

Figure 6—Dissector-coil assembly.



rotated to align the system electrically with the optical picture on the dissector cathode.

### 3.4 VIDEO-FREQUENCY AMPLIFIER

Figure 7 shows the circuit arrangement of the video-frequency amplifier in the camera unit. Connected by three plugs, the equipment can be

positive voltage to the cathode of the  $6SN7$  to allow only a very small amount of the blanking pulses to pass through the tube. This is accomplished by varying  $R3$ .

Any direct voltage appearing across  $R1$  due to random noise in the image dissector will remain at a constant value. Light striking the

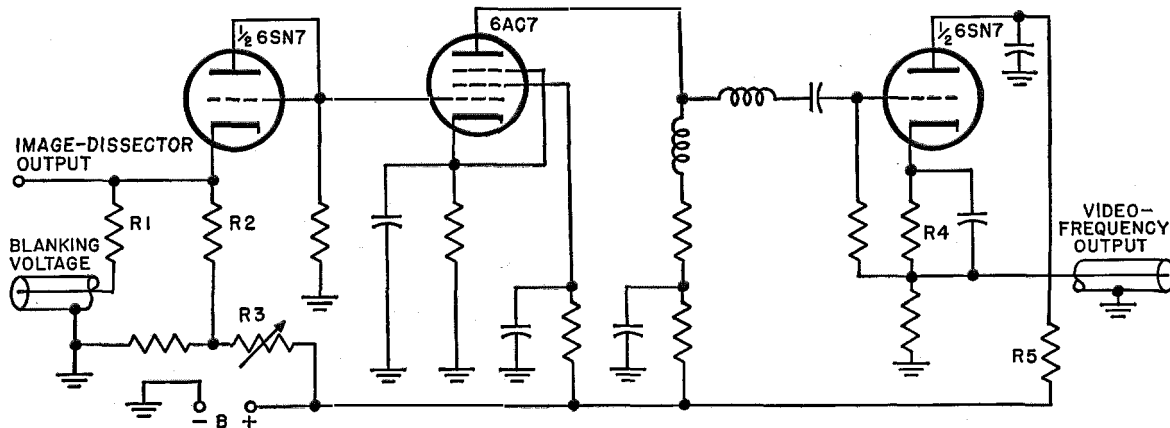

Figure 7—Circuit arrangement of video-frequency amplifier in the camera unit.

removed readily without the use of a soldering iron. The function of this unit is to mix the blanking pulses with the video-frequency output from the dissector collector, provide an automatic black-level setting, amplify the composite signal, and match the output to the transmission line.

Relatively large blanking signals are supplied to the cathode of the  $6SN7$  in series with the video-frequency voltage developed across  $R1$ , the load resistance in the collector circuit of the image dissector.

The initial clipping level of the black-level setter is adjusted by applying just enough

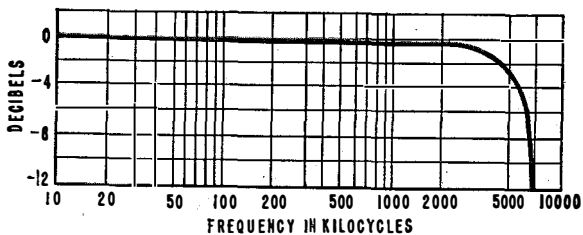

Figure 8—Response-frequency characteristic of the camera video-frequency amplifier.

dissector cathode causes an increase in collector current and the collector becomes more negative with respect to ground. This negative video-frequency voltage passes through the diode-connected  $6SN7$  to the grid of the  $6AC7$  amplifier, which has a gain of approximately 18. The pedestal will always be full but no video-frequency voltage can ever extend beyond the black level.

The second half of the  $6SN7$  is used as a cathode-follower to provide a low-impedance output to match the transmission-line impedance.  $R4$  and  $R5$  are chosen to give maximum linear output without exceeding the tube rating. The gain of this tube with the line properly terminated is approximately 0.3. Figure 8 gives the over-all response-frequency curve of the video-frequency amplifier.

### 4. Power Unit

Figure 9 shows the power unit with the case removed. Heater, plate, and multiplier voltages, scanning power, and blanking signals are supplied by it to the camera unit through a multicon-

ductor cable. The power unit also provides vertical and horizontal synchronizing pulses for the monitor.

The power unit draws approximately 100 watts and will operate on a line voltage between 95 and 135 volts. A meter with a red line to identify the correct operating voltage is mounted on the front panel with a control to adjust the voltage to that value.

#### 4.1 PLATE SUPPLY

The nominal plate power supply is at 275 volts after filtering. A bridge circuit utilizes eight 200-milliampere selenium rectifiers that are operated well within their normal ratings. The selenium rectifiers and bridge circuit were chosen for their ability to give trouble-free operation for extremely long periods of time. A variable resistor is inserted between the rectifier and filter to permit adjustment to proper output voltage under wide variations of line voltage.

#### 4.2 HORIZONTAL-DEFLECTION AND HIGH-VOLTAGE SUPPLY

A single *6L6* in a beam relaxor circuit, shown in Figure 10, provides horizontal scanning power and high voltage for the electron multiplier of the image-dissector tube. It is a free-running relaxation oscillator operating at approximately 21.5 kilocycles per second. It has a high degree of frequency stability over long periods of time. Small variations in frequency may be made by changing the value of the resistor between cathode and ground to compensate for the slight variation among production transformers. It is unnecessary to adjust this resistor unless the transformer has been replaced.

The horizontal-deflection transformer is shown in Figure 11. The plate winding of 500 turns is wound directly over the 100-turn grid winding. The high-voltage winding consists of 300 turns connected in autotransformer fashion. This

transformer must serve three interdependent functions. It must provide scanning power to the camera, high voltage to the dissector multiplier, and the return time (5.7 microseconds) must be slightly faster than the blanking return time. In addition, satisfactory scanning linearity must be maintained. A damping resistor in shunt with the

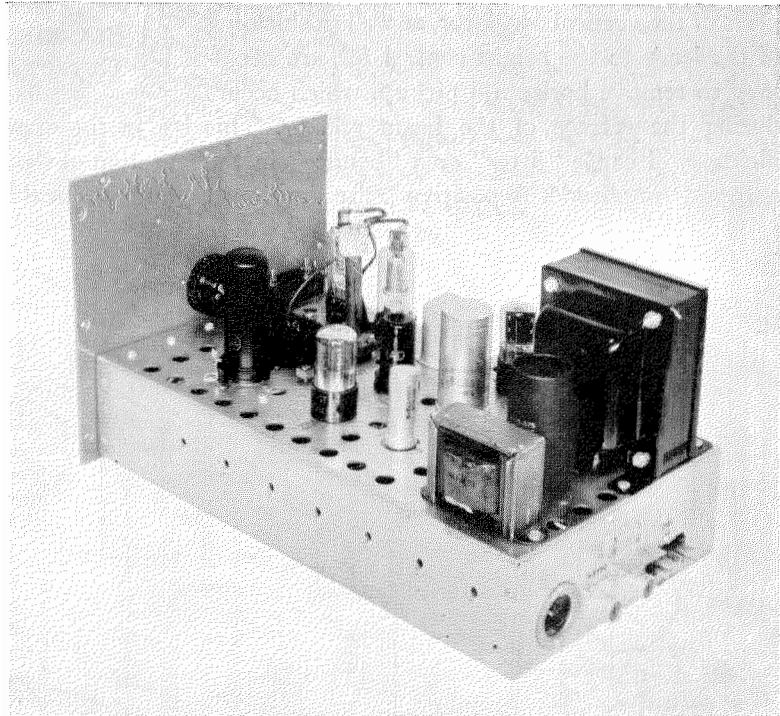

Figure 9—Power unit.

grid coil removes the overshoot that would otherwise occur through the scanning coils and cause severe nonlinearity. This transformer is tested at three times its normal operating voltage with no evidence of corona or breakdown.

The positive impulse derived from the horizontal-deflection transformer is rectified by the two *8016* rectifiers in parallel to provide a negative voltage of approximately 2500 volts for the multiplier. Since the current drain very nearly approaches the rating of a single *8016*, two are used in parallel as a precaution against failure in the field.

#### 4.3 VERTICAL-DEFLECTION CIRCUIT

The vertical-deflection circuit supplies vertical-deflection power to the camera, vertical

blanking pulses to the blanking-mixer, and vertical synchronizing pulses to the monitor.

One-half of the  $6SN7$  is used as a blocking oscillator. The frequency-determining time constant is provided by  $C2$  and  $R3$ . The lower end of the blocking-oscillator transformer is returned to the 6.3-volt heater winding on the power transformer. The capacitor  $C1$  connected to the plate of the vertical oscillator, as well as shielding of the leads to the height control  $R2$ , are necessary to remove horizontal pickup, which occurs during the retrace of the beam relaxor. This pickup will cause "jitter" or a "bounce" in the scanning amplitude. A positive pulse developed

across a resistor  $R4$  inserted in the cathode circuit of the vertical oscillator is used for blanking and monitor synchronization.  $C3$  reduces the horizontal pickup on this lead. The second half of the  $6SN7$  is used as a conventional vertical amplifier.  $R1$  is the vertical linearity control while  $R2$  is the height control.

#### 4.4 BLANKING-MIXER AND SYNCHRONIZING OUTPUT

In the upper part of Figure 10, the left-hand section of the  $6SN7$  is used to mix the horizontal and vertical blanking pulses while the other

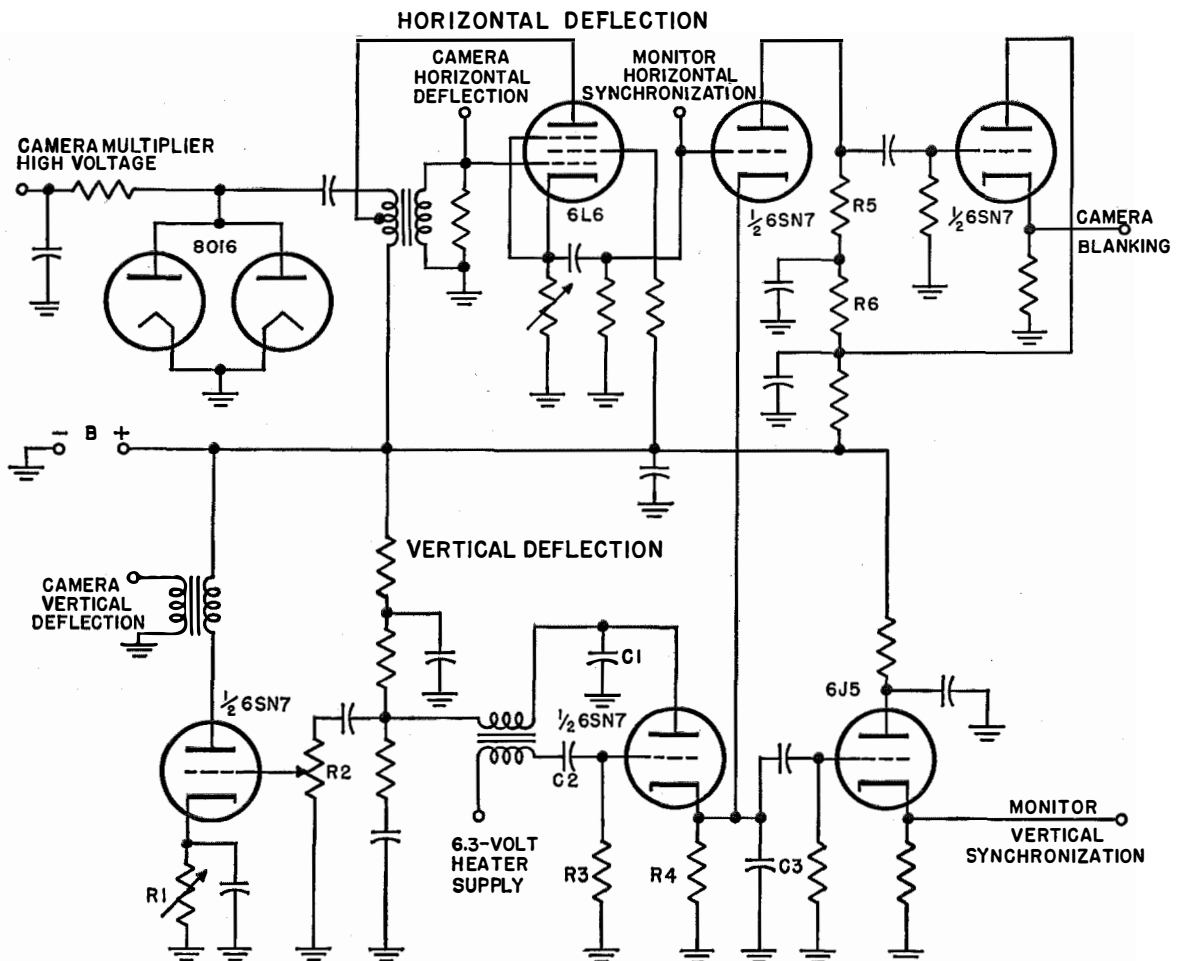

Figure 10—Circuit arrangement of power unit. The top portion shows the horizontal-deflection oscillator, blanking and mixing stage, and cathode-follower output tube. The vertical-deflection oscillator-amplifier and isolation amplifier for the vertical-synchronization voltages are at the bottom.

section serves as a cathode-follower. A positive vertical pulse is fed to the cathode of the blanking-mixer. A negative horizontal pulse from the beam relaxor cathode is applied to the grid of the blanking-mixer. A very low plate voltage is used, hence the blanking pulses cause very early saturation of the tube. This causes the base line of the blanking pulses to be absolutely flat, which is extremely important since at low light levels a shading component will otherwise appear. The values of  $R5$  and  $R6$  were carefully chosen to provide proper phasing of the horizontal blanking pulse with respect to the initial synchronizing pulse delivered to the monitor.

The  $6J5$  is a cathode-follower to isolate the cathode of the vertical oscillator from the monitor vertical oscillator and prevent a large pulse from being fed back to the power unit from the monitor vertical oscillator. This pulse, if applied across the cathode resistor of the power-unit vertical oscillator, is slightly out of phase with the cathode pulse and will make it impossible to derive a clean vertical blanking pulse from this point.

## 5. Monitor

The monitor resembles a conventional television receiver as far as the deflection system, high-voltage power supply, and video-frequency amplifier are concerned. Hence it need not be considered in great detail.

### 5.1 GENERAL

Physically, the monitor is so constructed that the cathode-ray tube and all other tubes may be installed before shipment. A small clamp keeps the  $6L6$  tube in its socket. All controls are available behind the hinged door at the front. The brilliance, contrast, and focus controls are screwdriver adjustments.

A plug termination for the video-frequency input cable is provided at the rear of the monitor. This terminating resistor is 120 ohms for all normal installations. However, where more than one monitor is used, the plug termination is changed to provide the proper impedance.

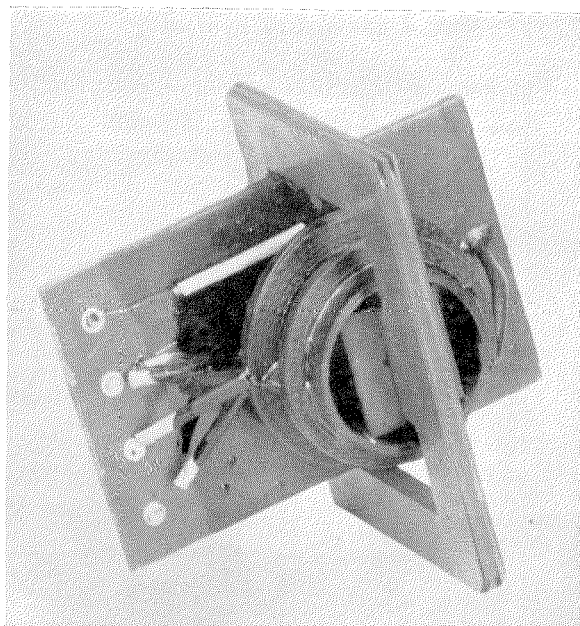

Figure 11—Horizontal-deflection transformer.

### 5.2 HORIZONTAL DEFLECTION AND HIGH-VOLTAGE SYSTEM

The horizontal synchronizing pulses are amplified in both sections of a  $6SN7$  double triode (Figure 12). They are then applied to a  $6L6$  used in a beam relaxor circuit to provide horizontal deflection and high voltage for the picture tube. Circuit-wise, this is quite similar to the beam relaxor in the power unit. However, synchronization is obtained by injecting the amplified synchronizing pulse into the screen circuit of the  $6L6$ , the frequency being controlled by a variable cathode resistor.

Basically, the beam relaxor transformer  $T1$  is similar to that in the power unit, with the addition of two heater windings for the  $8016$  rectifiers. The return time of the transformer must be faster than the camera blanking time, and is 5.7 microseconds.

Two  $8016$  tubes are used in a voltage-doubler circuit to produce about 8000 volts for the picture tube. The voltage-doubler circuit was chosen since it provides a highly efficient over-all circuit, particularly where power drain and return time are of great importance.

5.3 VERTICAL-DEFLECTION SYSTEM

The vertical-deflection system is very similar to that in the camera unit. *C1* and *R1* of Figure 12 are the frequency-determining ele-

ments in the vertical-oscillator circuit. Fixed elements are permitted here as tests have shown that this oscillator will stay in synchronization despite large variations of line voltage and other parameters.

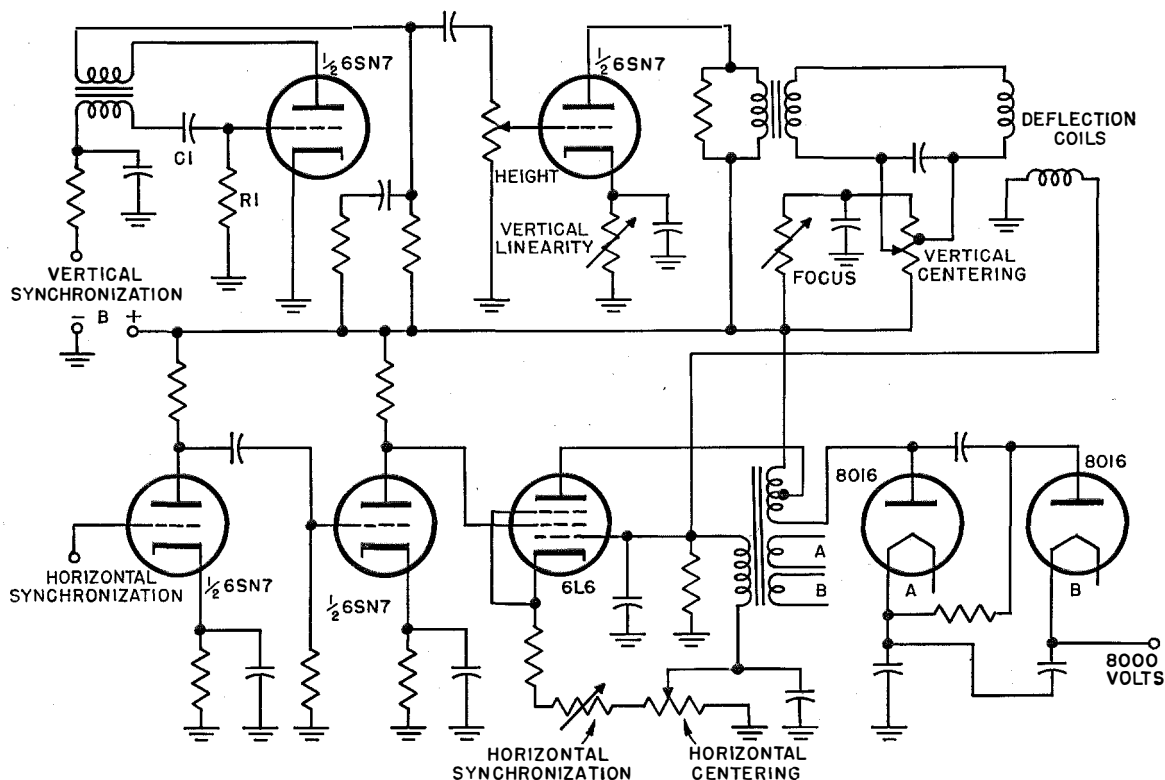

Figure 12—Deflection and high-voltage circuits in the monitor.

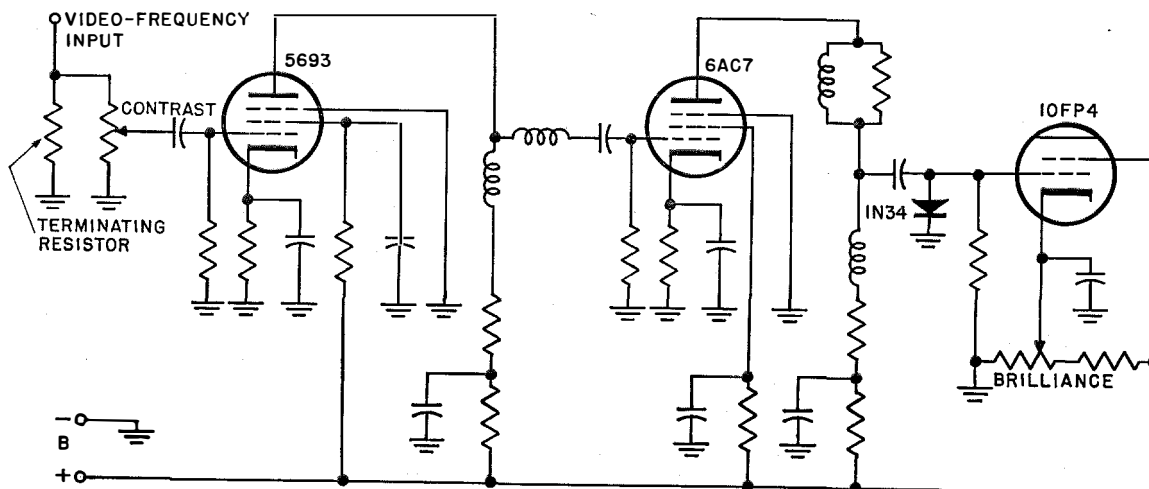

Figure 13—Video-frequency amplifier and picture-tube circuits in the monitor.

#### 5.4 POWER SUPPLY

The power supply is also very similar to that in the power unit, except that the output is at 350 volts. The ripple voltage appearing at this point is 0.6 root-mean-square volt.

A meter is used to set the width control for any given line voltage between 105 and 135 volts. This meter is behind the door on the front panel.

The width control is actually a variable resistor in series with the power-supply output, the voltage of which is measured on the meter. Therefore, adjustment of the horizontal scanning amplitude to the correct value assures that the voltages at all other points in the set will be within proper limits. If there should be any faults, it will be impossible to set the scanning width at the proper value and at the same time

to keep the meter pointer within a green area marked on the meter scale.

#### 5.5 VIDEO-FREQUENCY AMPLIFIER

A two-stage video-frequency amplifier with series and shunt peaking is shown in Figure 13. The first stage incorporates a type 5693 tube, which is the same as a 6SJ7 except that it is of the long-life type and is relatively free from microphonics. A 6AC7 is used as the second amplifier, the output of which is applied to the control grid of the 10FP4 picture tube. A 1N34 crystal diode is used as a partial direct-current restorer.

#### 6. Acknowledgment

The sponsoring of this development by the Diamond Power Specialty Corporation of Detroit, Michigan, is acknowledged.

In the Tidd station of the Ohio Power Company, the camera is focused on a boiler water-level gage and the monitor is mounted behind a panel in the control room.

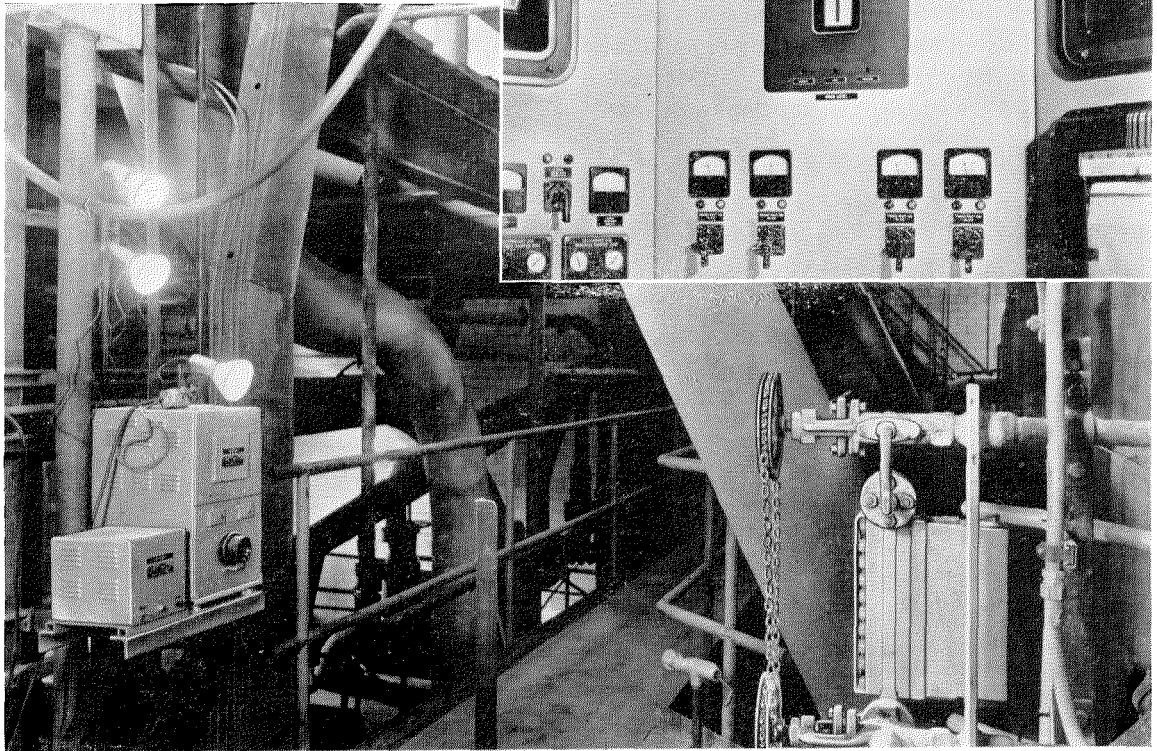

# ILS-2 Instrument Landing Equipment

By R. A. HAMPSHIRE and B. V. THOMPSON

*Federal Telephone and Radio Corporation, Clifton, New Jersey*

**C**HARACTERISTICS of the ILS-2 instrument landing equipment, meeting the major specifications of the International Civil Aviation Organization for a complete standard system, are described. Localizer, glide-slope, and marker-beacon installations are all of improved design and are monitored, started, and stopped from the airport control tower.

. . .

## 1. Historical

The modern instrument landing system, like its predecessors, is designed to permit a pilot to bring an airplane down directly over the airfield runway to within a few score of feet of the ground and thus make possible a safe landing under what might otherwise be hopelessly unfavorable conditions. All instructions from the ground are by continuous automatic radio transmissions and the pilot provides the only human interpretation required for the landing approach.

Almost two decades of development and operational experience have gone into the design of this aid to aviation. Its serious beginnings were in the work of Diamond and Dunmore<sup>1</sup> at the United States Bureau of Standards and in the developments of C. Lorenz, A.G.,<sup>2</sup> of Germany.

Lorenz equipment brought to this country was the basis of renewed development carried on at Indianapolis, Indiana, by the United States Civil Aeronautics Administration and the International Telephone Development Corporation.<sup>3</sup>

The equipment at the time of the Indianapolis tests consisted of a localizer, glide slope, two beacons, and a control-tower system. The func-

tions of these were identical with their modern counterparts, but the glide slope operated on the principle that the aircraft followed a line of constant field strength. In the modern system of glide-slope operation, the path is determined by an equisignal zone. This latter had been experimented with at Indianapolis; development was completed under Air Force sponsorship at the International Telephone and Telegraph laboratories in New York. The control-tower equipment was ignored until the war was just ending.

A modest program of equipment installation for the Civil Aeronautics Administration followed the Indianapolis work and continued until the United States entered the second world war. The war emphasized production and use and, even though only a very brief series of evaluation tests had been made, the basic system employed by the Civil Aeronautics Administration was adopted by the United States Army Air Force.

Thus, there was developed the *SCS-51* instrument landing system, later to be known as the Army Air Force's instrument approach system.<sup>4,5</sup> It was a mobile equipment, designed to be set up quickly at an airport and to be operated by inexperienced enlisted personnel. The system consisted of a localizer, glide slope, and marker beacons, which were usually three in number although many installations were made with only one or two. The localizer operated on any one of 6 channels between 108.3 and 110.3 megacycles per second. The glide slope originally operated only on 335.0 megacycles, but was soon modified to operate on 333.8 and 332.6 megacycles as well. Marker beacons operated on 75 megacycles.

Hundreds of these systems were produced during the war. The principal technological improvements were the development of the equi-

<sup>1</sup> H. Diamond and F. W. Dunmore, "Radio Beacon and Receiving System for Blind Landing of Aircraft," *Proceeding of the I.R.E.*, v. 19, pp. 585-626; April, 1931.

<sup>2</sup> R. Elsner and E. Kramar, "Ultra-Short Wave Radio Landing Beam," *Electrical Communication*, v. 15, pp. 195-206; January, 1937.

<sup>3</sup> W. E. Jackson, A. Alford, P. F. Byrne, and H. B. Fischer, "Development of the Civil Aeronautics Authority Instrument Landing System at Indianapolis," *Electrical Communication*, v. 18, pp. 285-302; April, 1940.

<sup>4</sup> H. H. Buttner and A. G. Kandoian, "Development of Aircraft Instrument Landing Systems," *Electrical Communication*, v. 22, n. 3, pp. 179-192; 1945.

<sup>5</sup> S. Pickles, "Army Air Forces' Portable Instrument Landing System," *Electrical Communication*, v. 22, n. 4, pp. 262-294; 1945.



signal glide slope, the development of both glide slopes and localizers that could operate over a band of frequencies, and, most important, the development of equipment and production techniques that resulted in completely prefabricated equipments. The need for tune-up of the antenna systems by highly trained technicians at the time of installation, which characterized prewar equipments, had been eliminated.

While the Air Force's procurement of the *SCS-51* was under way, the Civil Aeronautics Administration completed the installation of instrument landing systems at major airports in the United States. These installations did not include glide-slope equipment as the entire production of this apparatus was going to the Air

Force, but they did include localizer, marker beacons, and control-tower equipment.

The Civil Aeronautics Administration recognized the necessity for continuous monitoring of the complete system from the control tower, and it proved the desirability of keeping this monitoring as simple as possible. In prewar equipments, the location of the glide-slope and localizer beams had been displayed on meters in the control tower, and the operator was required to deduce from these meter readings whether the beams were in the proper positions. The Administration soon found that it was better to have a completely automatic means of determining the propriety of the beams and to provide only alarm lights and a horn in the tower to warn of improper operation.

In addition to this, the Administration recognized the need for communication channels between aircraft and the control tower, and it developed the first localizer with simultaneous

Figure 1—Components and placement of the various parts of an instrument landing installation for a single landing strip are shown below.

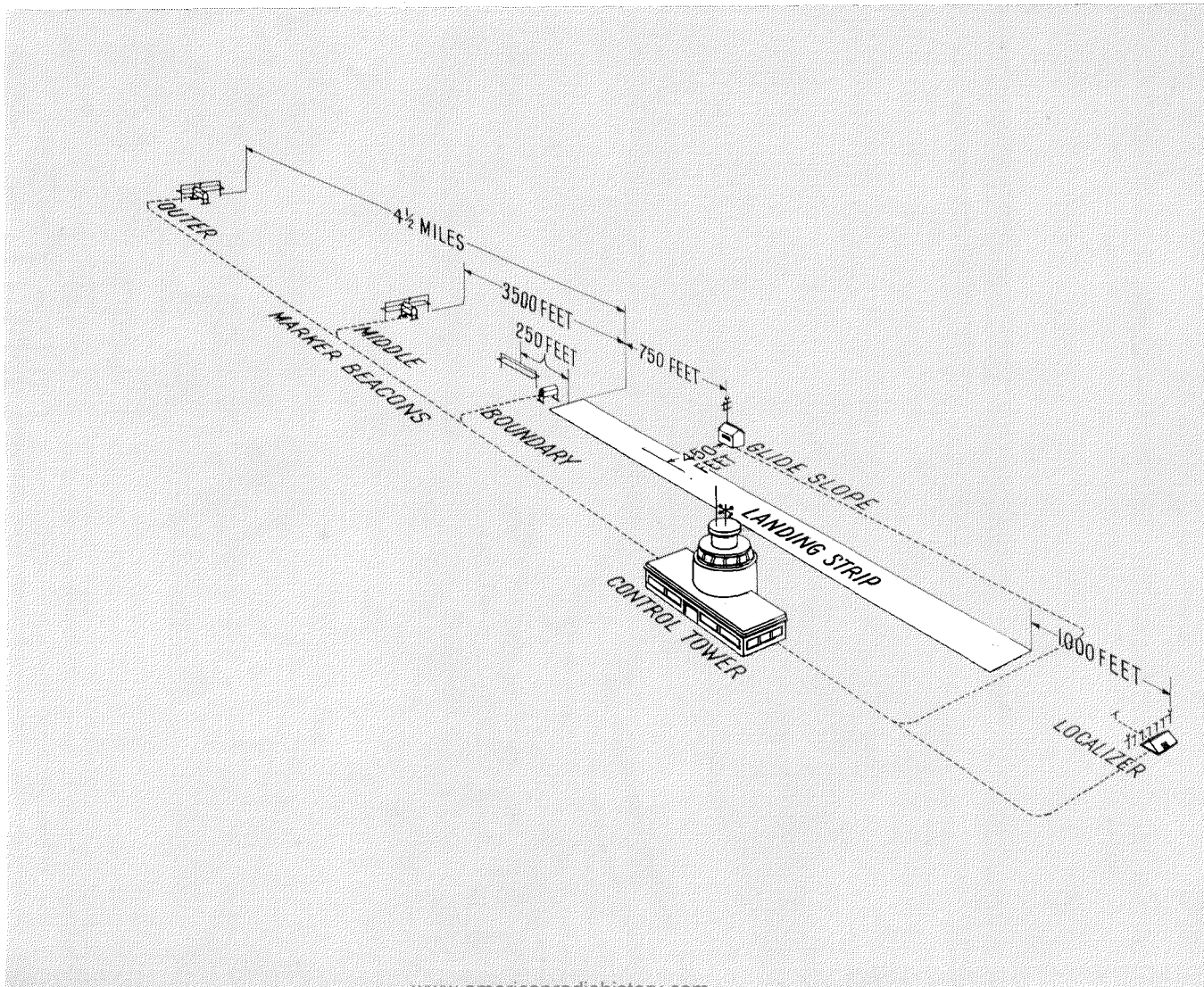

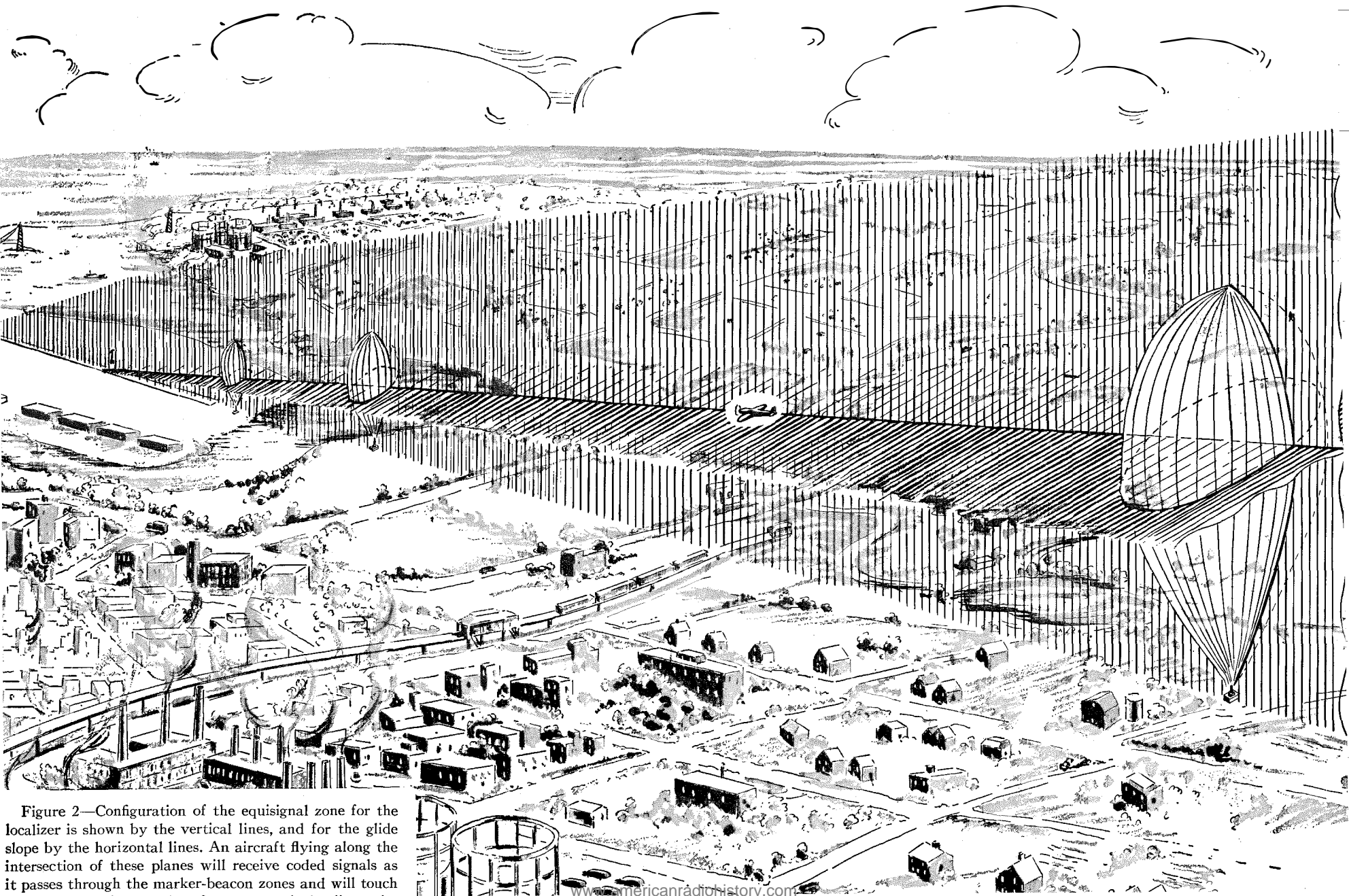

Figure 2—Configuration of the equisignal zone for the localizer is shown by the vertical lines, and for the glide slope by the horizontal lines. An aircraft flying along the intersection of these planes will receive coded signals as it passes through the marker-beacon zones and will touch

voice. All Administration localizers were then equipped for simultaneous voice operation.

The Civil Aeronautics Administration could not exercise the same high priority ratings in the procurement of its equipment as could the Air Force. Therefore, it had to divide its localizers into units that were purchased separately, and the advantages of unified design and prefabrication were denied. Wherever an Administration localizer went, there also went highly trained technicians to install and adjust the equipment. The large number of installations made under these difficult circumstances speaks highly of the ability of the Administration personnel.

At the end of World War 2, the widespread use of these systems created demands from all over the world. Temporary measures were taken to meet this demand and included the use of surplus *SCS-51* systems and the production of *FTR-51* equipment by Federal Telephone and Radio Corporation.

These *FTR-51* systems were the first commercial version of the *SCS-51* for civilian use, and were complete in that they included localizer, glide slope, three marker beacons, and a control-tower equipment. They did not include localizer simultaneous voice, nor did they cover the extended range of frequencies that by this time had been found desirable. The control-tower system was patterned after the military remote-control and monitoring equipment, development of which was fostered by the Air Force at Federal Telephone and Radio Corporation just before the end of the war.

The Provisional International Civil Aviation Organization (which later dropped the word "Provisional" from its name) met in 1945 and 1946; it clarified the postwar concept of the instrument landing system and published certain recommendations<sup>6</sup> thereon. Its important contributions were:

A. Localizer and glide-slope frequency channels were specifically allotted between 108 and 112 megacycles, and between 329 and 335 megacycles, respectively.

B. The use of three marker beacons was recommended, and the inclusion of compass-locater stations<sup>7</sup> in the basic standard system was tacitly abandoned.

<sup>6</sup> Provisional International Civil Aviation Organization Document 2553-COT/26; January, 1947.

<sup>7</sup> Compass-locater stations are low-power low-frequency beacons associated with two of the marker beacons in some installations. They are used to establish the aircraft

C. The use of simultaneous voice in conjunction with the localizer was established.

D. The proposed change of localizer modulation from the 90- and 150-cycle tones to phase-comparison operation<sup>8</sup> was abandoned.

The main work of the Provisional International Civil Aviation Organization was well done, and the way was cleared for the development and production of an instrument landing system of unified design.

## 2. *ILS-2 System*

The *ILS-2* equipment complies with all major requirements set up by the International Civil Aviation Organization, including Document 2553-COT/26; January, 1947 and Document 6625-COM/521; March, 1949. The basic specifications for the standard installation portrayed in Figure 1 do not differ from the *SCS-51* system.

The localizer generates a radio-beam course down the length of the runway, which provides left-right guidance to the aircraft, and extends for a minimum of 25 nautical miles. The rate of descent of an aircraft approaching for a landing is indicated by the signal from the glide-slope equipment, which generates a path that touches the landing strip at the proposed point of contact and extends outward and upward at an angle, which may be set between 2 and 4 degrees, from the landing-strip surface. Three marker-beacon installations provide checks on the distance to the point of contact.

The radiation-pattern paths resulting from these equipments are shown in Figure 2. The intersection of the localizer and glide-slope equisignal zones determines the proper approach path; any deviation from this path is shown on the flight-deviation indicator (a cross-pointer instrument) in the aircraft.

The approximate radiation patterns of the three marker-beacon installations are shown as the balloon-shaped zones intersecting the approach path.

heading on the localizer course. The aircraft "homes" on the beacons with the aid of its radio compass.

<sup>8</sup> In phase-comparison operation, a 30-cycle tone that amplitude modulates the carrier is compared with another 30-cycle tone that frequency modulates a 10-kilocycle subcarrier. This modulation system is used in the very-high-frequency omnidirectional radio range of the Civil Aeronautics Administration and is contemplated for its localizers. No decision regarding its international use has been taken.

Simultaneous voice transmission from the localizer is made without interruption of its course modulation. The radiation pattern of the voice transmission is approximately omnidirec-

For the above reasons, careful attention has been given to the design of the monitoring and control circuits of the *ILS-2* system. In Figure 3, are shown the various monitoring and control

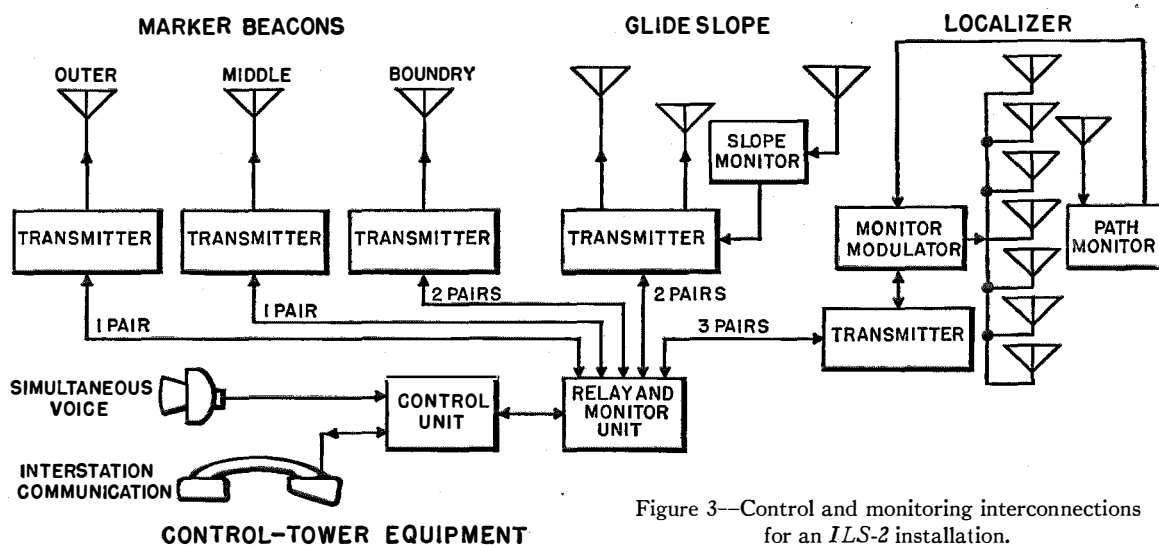

Figure 3—Control and monitoring interconnections for an *ILS-2* installation.

tional, and is useful over a range of about 20 miles. Whenever speech is not being used, a Morse-code identification signal is automatically transmitted.

The *ILS-2* localizer covers the frequency band in two steps of 108 to 110 and 110 to 112 megacycles. Different transmission lines to the antennas are used for the two halves of the band. Otherwise, the localizer requires only simple adjustments to cover the band. The glide-slope equipment requires only adjustment to cover the specified band of 329 to 335 megacycles, and the marker beacons all operate at 75 megacycles.

### 3. Unified System, Alarm and Control Circuits

The most important characteristic of an instrument landing system is *dependability*. Complete control of all its component equipments is necessary with immediate warning of any faulty operation. These indications must be available to both the aircraft pilot and the personnel in the airport control tower in order that instructions given to the pilot may be accurate. A faulty condition of which the pilot has had no warning may cause loss of life, or at least a loss of confidence in the system.

interconnections for an installation of the single type.

For a dual installation, stand-by transmitters and monitors are supplied for the localizer and glide slope; also, marker-beacon transmitters and certain power-supply equipment are duplicated. In general, duplicates are supplied only for those parts containing vacuum tubes. In the event of faulty operation of any part of the system or a fault in the monitor itself, the station is turned off to prevent misleading signals from being transmitted, and a warning signal lamp lights and an alarm sounds in the control tower.

The operator may then attempt to turn the equipment back on (by means of a switch on the control unit), since the condition may have been a temporary disturbance caused by a vehicle or aircraft moving close to the antenna arrays of the localizer or glide slope. If this attempt is not successful, he may switch over to the stand-by equipment in a dual installation. Switchover in this case is not automatic, because it might occur unnoticed by the operator. If a fault then occurred in the spare, there would be two inoperative equipments and service would have to be suspended. It is better that a fault be called to attention by requiring the operator to switch manually to the spare.

The monitors of the glide-slope and localizer equipments check for three conditions:

- A. Shift of the equisignal zone beyond chosen limits.
- B. Reduction of 90- or 150-cycle modulation.
- C. Reduction of field strength below a chosen percentage of normal.

In front of the localizer array and in line with the course is a simple crystal receiver that picks up a sample of the signal, demodulates it, and feeds it to the monitor unit. The 90- and 150-cycle tones are compared to test the accuracy of course alignment, and the combined level is measured to check that the field strength and modulation depths are satisfactorily maintained. Since the transmitter produces the course-identifying tones by mechanical modulation of a single source of radio-frequency power, adequate modulation depth on-course is assurance that a difference in tone levels exists off-course. The single monitoring receiver is thus able to prove that the localizer course actually exists, not merely that there is equality of 90- and 150-cycle tones where the course should be. There is an additional circuit that monitors the voice-channel power amplifier. Failure of this amplifier, which results in a change in the width of the course, causes a characteristic flashing of the monitor alarm lamp in the control-tower equipment.

The monitoring of the glide slope is done by circuits identical with those of the localizer monitor. The chassis containing the measuring circuits are, in fact, interchangeable. In each of these circuits, a delay adjustable between 8 and 15 seconds is provided after the monitor first detects a fault before the station is shut down and the control-tower alarm sounds. This delay precludes unnecessary alarms when vehicles and aircraft pass close to the antenna arrays.

In the marker-beacon transmitters, monitors check for the presence of the proper tone-modulated keyed emission. Circuits identify the presence of tone modulation and detect the failure of keying in either the key-down or key-up positions.

Connection of the various transmitters to the relay and monitor unit in the control tower is through telephone-line pairs. Signaling and control functions over these pairs are accomplished

through the use of power-line-frequency pulsed signals, reducing the possibility of interference and permitting the use of regular telephone lines: no direct-current continuity is required. A system of sound-powered telephones for inter-station communication is included. Because the middle and outer beacons are respectively 3500 feet and  $4\frac{1}{2}$  miles from the landing strip, only one pair of lines is used to connect each of these, and the beacon operation is interrupted during use of the telephone. This conserves telephone lines. For each of the other three equipments, a pair is used for monitoring and control, and a separate pair for telephony. For the localizer, a third pair is used for transmission of simultaneous voice signals from the control-tower operator.

The relay and monitor unit includes a 5-pen recorder to show permanently on charts the operation of the various pieces of equipment. Photographs of the relay and control units are given in Figures 4 and 5.

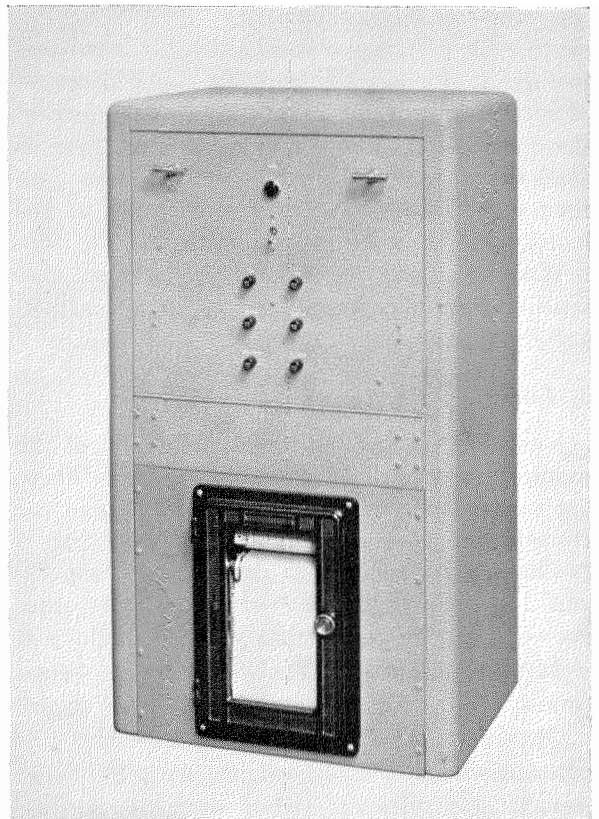

Figure 4—This relay unit is placed in the control tower along with the control unit. The 5-pen recorder give as permanent index of the operation of the system.

From the foregoing, it may be seen that the entire equipment may be monitored, started, and stopped from the control tower. Such centralization of these functions reduces the possibility of an accident through some phase of the operation passing unnoticed.

#### 4. Ease of Installation

Another interesting feature of an equipment that has been "streamlined" is the possibility of reducing the amount of labor and, hence, expense of installation. In previous instrument landing systems, it was found necessary to provide engineering supervision of the installation. This was due in large part to the fact that the lengths of the radio-frequency cables connecting the glide-slope and localizer transmitters to their antennas are extremely critical. Because of recent improvements in the manufacture of these cables, it is now possible to age them so that they are dimensionally stable. They are then cut to the proper electrical length at the factory and the connectors attached.

With the aid of instruction books alone, it is possible for radio technicians to install, adjust, and maintain the equipment.

#### 5. Localizer Equipment

Views of the localizer transmitter and of the monitor-modulator are given in Figure 6. There are two radio-frequency power amplifiers in the transmitter. One supplies carrier power to a mechanical modulator for generation of the 90- and 150-cycle sideband energy, and the other provides carrier power that is plate modulated either with a keyed 1020-cycle station-identification signal or with the simultaneous voice signal.

Operation of the mechanical modulator is conventional and in accordance with the time-proved principles of earlier equipments. The course-producing tones are generated by mechanical modulation of the output of a single amplifier, thus assuring maximum stability and



Figure 5—Control unit. Switches and alarm lamps are on the panel; the microphone for simultaneous voice is at the right. The telephone handset is for communication with other parts of the system.

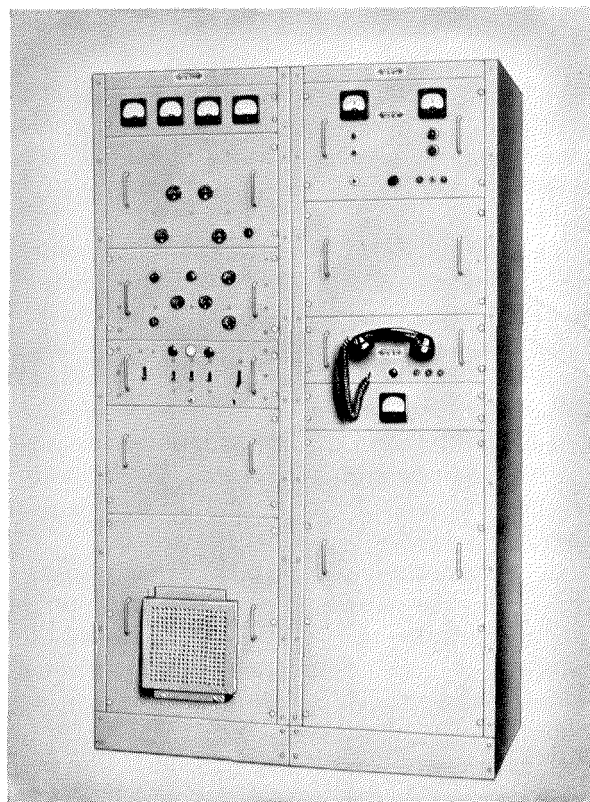

Figure 6—Localizer transmitter is at the left, and the monitor-modulator at the right.



reliability. The output of the other power amplifier is fed to the center antenna of the array through a hybrid circuit (radio-frequency bridge) that is balanced by a dummy antenna. By utilizing equal amounts of carrier power from the two channels, and by proper adjustment of the phase relations, any loss of carrier power in the dummy antenna is avoided and maximum over-all efficiency is retained.

The separated sideband and carrier energies are applied in proper phase to an array of 7

Connection of the monitor-modulator to the array is by means of 7 prefabricated twin-conductor lines of critical length. All power-dividing networks, the hybrid circuits, and the dummy antenna are contained in the monitor-modulator unit.

### 6. *Glide-Slope Equipment*

A view of a typical glide-slope installation is shown in Figure 9. The hut houses the transmitter shown in Figure 10. Except that there is

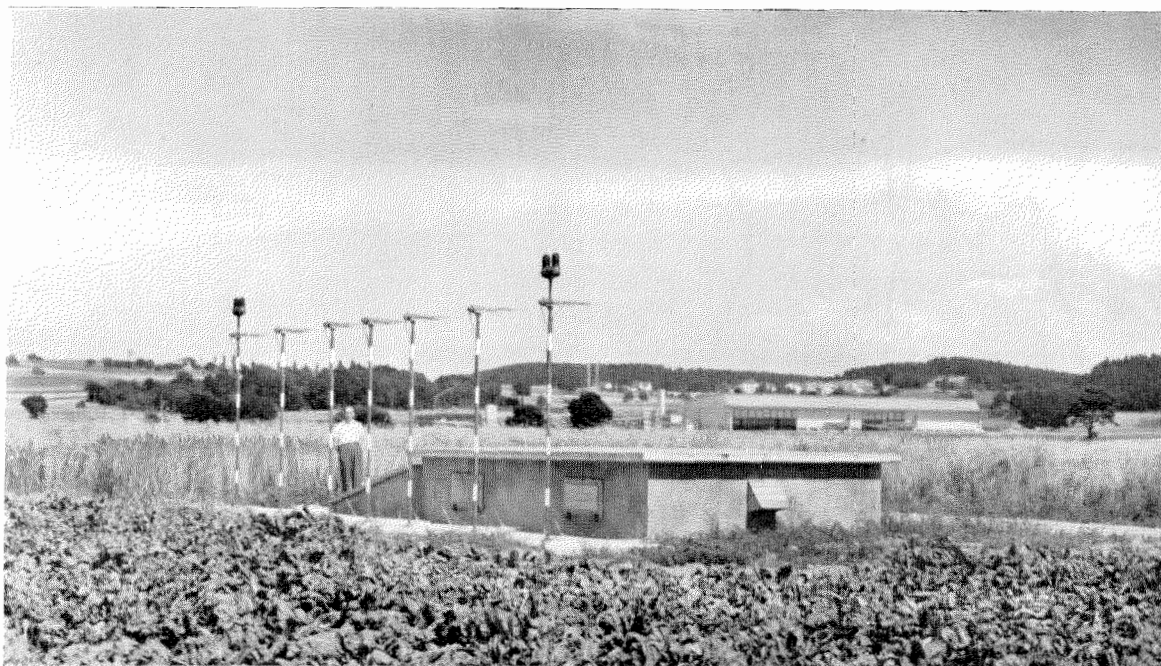

Figure 7—Localizer installation at Kloten Airport in Zurich, Switzerland. Twin obstruction lamps are mounted on the end antennas of the array.

V-type antennas (Figure 7), and produce the radiation pattern illustrated in Figure 8.

The small course-monitor box with its antenna is mounted on a post 200 feet in front of the array, and the detected signal is transmitted back to the monitor-modulator through a buried cable.

No part of the localizer equipment extends above ground by more than 12 feet. This is necessary because the equipment is directly in line with the runway. All of the localizer except the array is placed in a hut below ground level.

no necessity for simultaneous voice and that the frequency is higher, making for more compact apparatus, the operation of the glide-slope generating equipment is similar to the localizer.

Power at the carrier frequency is applied to a mechanical modulator where, with the aid of a radio-frequency bridge, modulation at 90 and 150 cycles is produced. Radiation of 90-cycle-modulated power from the lower antenna, and 150-cycle-modulated power from the upper antenna (Figure 9) results in the combined radiation pattern of Figure 11.



The angle of the glide slope is adjustable in steps of  $\frac{1}{4}$  degree between 2 and 4 degrees. A false slope is produced at about 5 times the angle of the proper slope. Since the sense of indication in an airplane flying the false slope is reversed, and since the angle is so great, there is no danger of the false slope being mistaken for the proper slope.

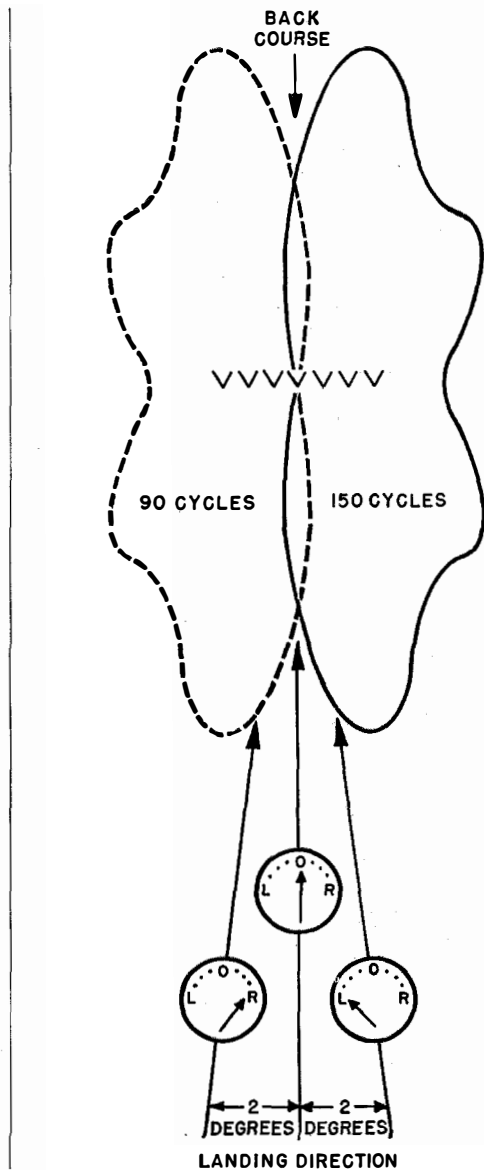

Figure 8—The left-hand localizer pattern is modulated with 90 cycles and the right-hand with 150 cycles. When the aircraft approaches along the middle, equal amounts of modulated signal are received. If the aircraft is to the left or right, unbalance causes a "fly-right" or "fly-left" indication on the instrument.

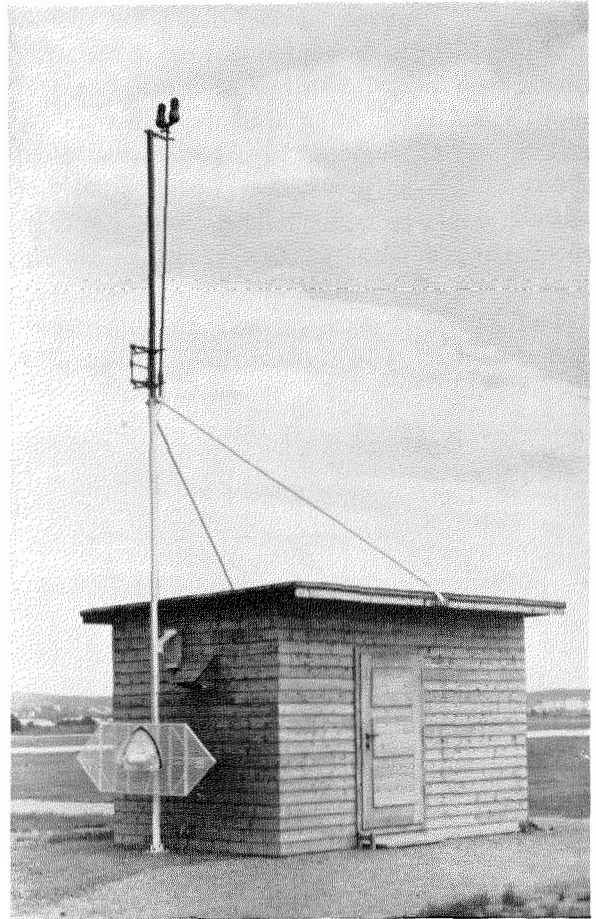

Figure 9—Glide-slope installation at Kloten Airport in Zurich, Switzerland. Two antennas are mounted on the pole, one above the braces and the other near the ground.

A monitor similar to that used for the localizer is placed about 200 feet in front of the glide-slope hut. Since the equipment is about 450 feet to the side of the landing-strip center line, it does not constitute a hazard, and all of the equipment is placed in a small hut above ground.

### 7. Marker-Beacon Installations

For the standard installation, three marker beacons are used. Their construction and circuitry are identical as all operate on 75 megacycles. The modulation used for the outer beacon is 400 cycles, keyed with continuous dashes; for the middle beacon, 1300 cycles, alternate dots and dashes; and for the boundary beacon, 3000 cycles, continuous dots. Choice of

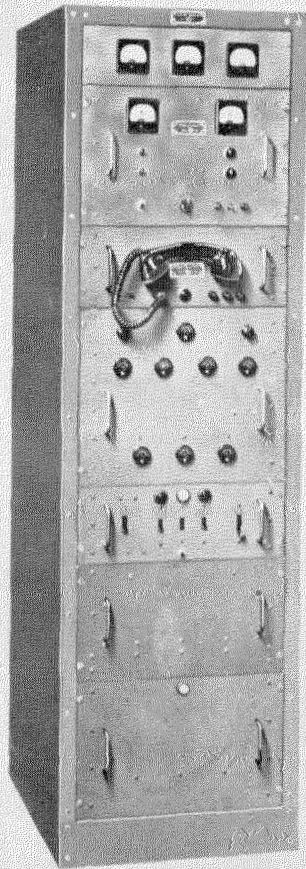

Figure 10—The cabinet houses the glide-slope transmitter, the mechanical modulator, and a chassis for the monitoring circuits.

modulating frequency is made by suitable connection of resistors in the equipment, and keying code by means of replaceable cams on the keyer unit. The transmitter, monitor, and power supply are all mounted in a weatherproof steel cabinet (Figure 12). A complete installation for the outer or middle beacons is shown in Figure 13.

Since the boundary marker beacon is only 250 feet from the start of the landing strip, clearance is important and height is reduced by mounting the antenna near ground, with the cabinet beside it instead of underneath. Maximum height of a boundary-marker installation is 48 inches.

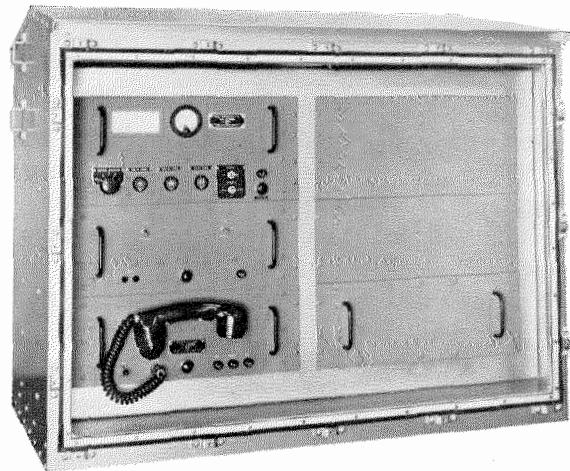

Figure 12—Marker-beacon cabinet. Left rack contains, from top to bottom, the transmitter, monitor, and a relay panel. The power supply is at the bottom of the right rack. Spare space is for a stand-by transmitter.

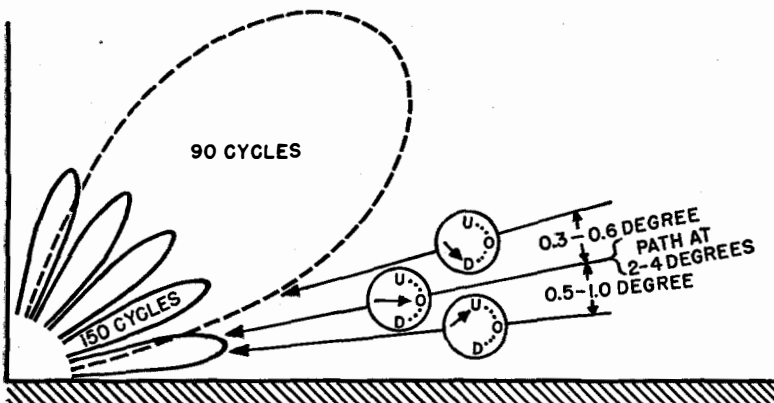

Figure 11—Vertical-plane radiation patterns of the glide-slope equipment. Relative amounts of 90- and 150-cycle modulation received in the aircraft determines the indicator reading.

### 8. Power Equipment and Power Requirements

Operating from 115-volt 60-cycle supply, the power requirements for an *ILS-2* instrument landing installation are: beacons, 0.5 kilovolt-ampere; glide slope, 1.5 kilovolt-amperes; and localizer, 3.0 kilovolt-amperes. While the three marker-beacon installations will operate at any frequency between 50 and 60 cycles, the motor-driven mechanical modulators of the localizer and glide-slope equipment require that the supply

be exactly 60 cycles. For operation of this equipment from sources other than 60 cycles, an electronic crystal-controlled frequency converter has been designed. Using thyatron tubes in the power circuits, it operates by conversion of the input to direct current, and reconversion of this direct current to alternating current at exactly 60 cycles. Maximum 60-cycle continuous output is 0.6 kilovolt-ampere, but peak output sufficient for starting the motor is available.

Since all of the equipment of the system operates at inputs of 115 volts (nominally), provision is made to supply autotransformers with or without voltage regulators where use of a different voltage is necessary.

### 9. Dual Installations

Because an instrument landing system must be extremely dependable, it is preferable that stand-by equipment be available for those parts containing vacuum tubes. For a dual installation, therefore, the following stand-by equipments are supplied: localizer transmitter, monitor, and frequency converter (if used); glide-slope transmitter, monitor, and frequency converter (if used); and marker-beacon transmitters (one for each beacon).

For a dual localizer, a duplicate transmitter is added on the right-hand side of the monitor-modulator (Figure 6). An additional monitor chassis like that at the top of the monitor-modulator cabinet in Figure 6 replaces the blank panel immediately below it. Transmitter- and antenna-transfer relays are installed in the same cabinet. In the glide slope, the dual installation requires the addition of another cabinet like that shown in Figure 10. The mechanical modulator (lowermost unit in Figure 10) is replaced by a blank panel in the added cabinet, and the transfer relays are mounted behind this panel. In the marker-beacon cabinets, all additional units are installed in place of existing blank panels.

As mentioned above, the start-stop and transfer functions are all controlled from the

airport control tower, where no additional equipment is required for a dual installation.

### 10. Widespread Acceptance

These *ILS-2* commercial equipments seem destined to follow their military predecessors all over the world. Equipments of this type are installed or in the course of installation in Argentina, Australia, Denmark, France, Ireland, Italy, Lebanon, The Netherlands, Norway, Portugal, Sweden, and Switzerland. *FTR-51* equipments have been installed in Belgium, Canada, France, and Sweden.

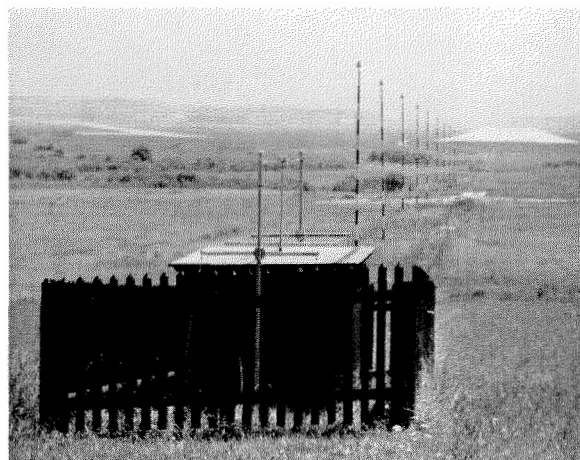

Figure 13—Marker-beacon installation at Kloten Airport. A dipole antenna and its counterpoise are mounted above the transmitter cabinet.

### 11. Conclusion

An instrument landing system has been designed that, in addition to meeting major requirements of the International Civil Aviation Organization, features an integral alarm and control system. It provides for simultaneous radiation of voice signals from the localizer without interruption of its function as a landing aid and is unique in that construction is completely prefabricated, thus simplifying the work of installation.

# Test Set for Impedance-Frequency Measurement on Coaxial Cables

By A. F. BOFF

*Standard Telecommunication Laboratories, Limited, London, England\**

**D**ETERMINATION of the characteristic impedance, attenuation constant, phase constant, and velocity ratio of long lengths of coaxial cable is discussed. It is shown that, by avoiding frequency-dependent parameters in the measuring circuits, precise measurements may be made with a rapidity impossible with previous methods. A description is given of a portable test set covering the range from 5 to 30 megacycles per second.

• • •

At radio frequencies, the impedance-frequency characteristic of a long coaxial cable has the form illustrated in Figure 1. This is demonstrated in

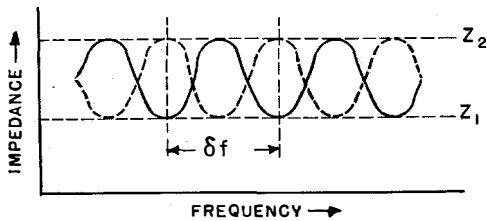

Figure 1—Impedance-frequency characteristic of a long coaxial cable at radio frequencies. The solid line is for a short-circuited cable and the broken-line curve is for the open-circuited condition.

Section 11.2 of the appendix. The impedance  $Z$  is complex, but becomes purely resistive at the extreme values  $Z_1$  and  $Z_2$ . From measurements of  $Z_1$ ,  $Z_2$ , and  $\delta f$ , together with the physical length of the cable, the characteristic impedance, attenuation constant, phase constant, and velocity ratio may be deduced. Of the existing techniques for measurements on coaxial cables at radio frequencies, the radio-frequency bridge<sup>1</sup> and Hartshorn and Ward susceptance-variation set<sup>2</sup> are most commonly used in England. The latter provides an accurate means of measuring short

cables, but is not suitable for lengths of cable exceeding a few yards owing to the large amount of damping introduced into the resonant circuit.

For testing cables in long lengths and particularly for measurements in the field, bridge methods have so far been used exclusively. Radio-frequency bridges, however, require careful balancing at each frequency and employ a detector (usually a radio receiver) that must be separately tuned. The process of locating the purely resistive impedances  $Z_1$  and  $Z_2$  by successive adjustments of frequency is, therefore, tedious.

It would clearly be of great advantage if a direct indication could be given of the magnitude of the cable impedance, especially if changes of frequency did not involve any adjustments apart from the tuning of the oscillator. The impedance-frequency characteristic of Figure 1 could then be followed as quickly as desired by the turning of a single knob. Such a method would also be invaluable in checking terminated repeater lengths where the impedance-frequency characteristic due to irregularities in the line or mismatch at the joints is erratic. Routine checks on such lines require literally hundreds of bridge readings to ensure detection of sharp irregularities. Consideration of these features led to the development of a test set based on the elementary circuit given in Figure 2.

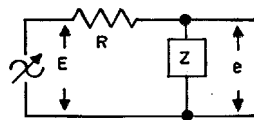

Figure 2—Elementary circuit of test set.

Here  $Z$  may be expressed in terms of the constant resistance  $R$  and the ratio of the voltages  $e/E$  if the phase angle is known. This ratio may conveniently be determined by means of the circuit of Figure 3. The values obtained from this circuit by rectification of these radio-frequency

\* The author is now with Marconi's Wireless Telegraph Company.

<sup>1</sup> Numbered references are to the bibliography in Section 12.

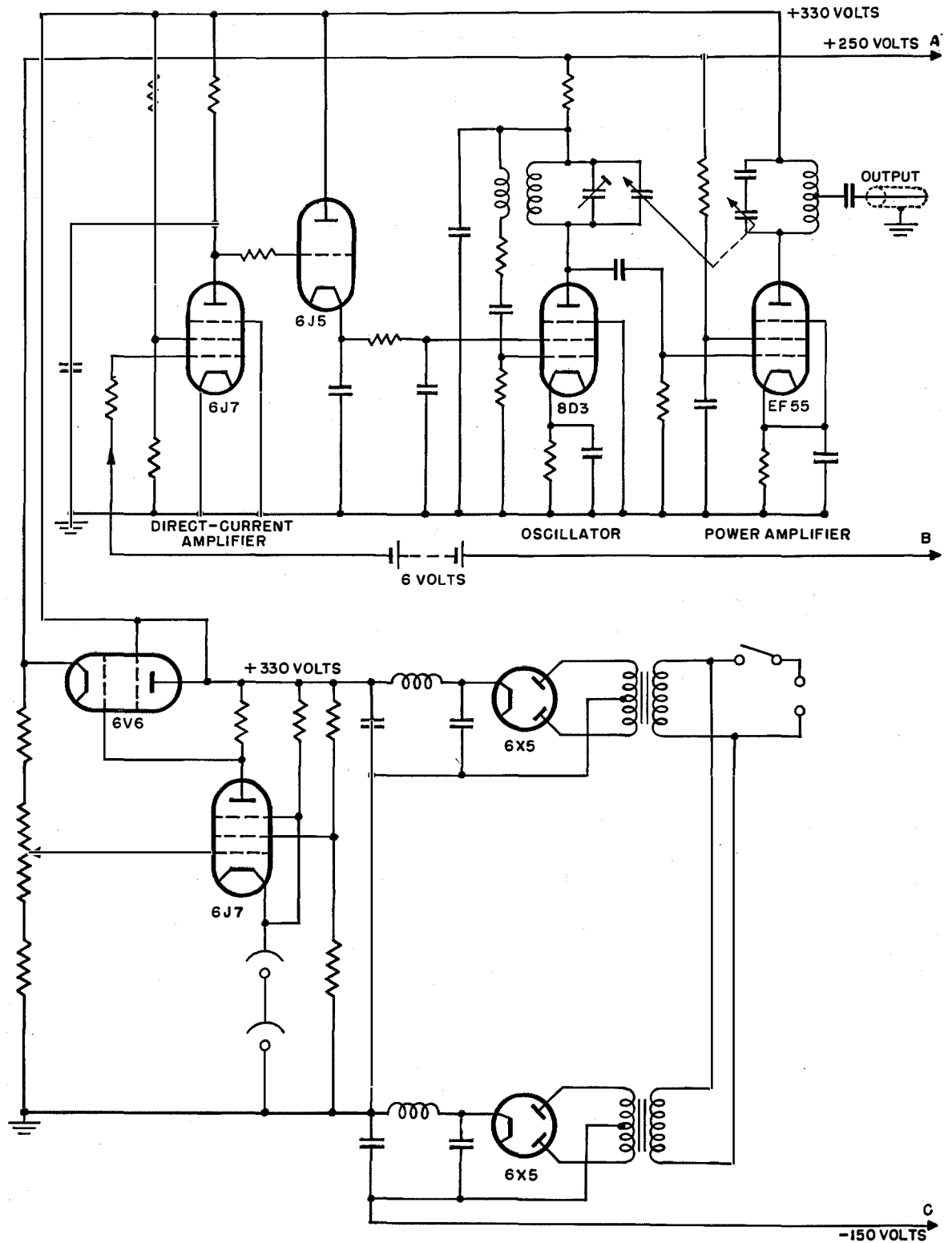

Figure 4—Circuit diagram of oscillator, power amplifier, feedback amplifier, and power supply. The leads A, B, and C connect to the corresponding leads in Figure 6.

voltages will not correspond exactly with the characteristic of Figure 1 for all values of  $Z$ , since  $e$  is dependent on the phase angle but, at the extreme values of  $Z$ , i.e.,  $Z_1$  and  $Z_2$ , they will

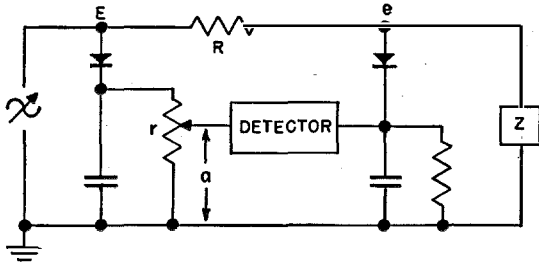

Figure 3—Basic circuit of detector. At balance,  $e/E = a/r$ . By rectifying the radio-frequency voltages  $E$  and  $e$  at their points of origin, direct-current-operated detection equipment may be used remotely from these points.

fall into line since at these points the phase angle is zero. It is shown in Section 11.3 of the appendix that the minimum and maximum values of this ratio  $e/E$  always correspond to  $Z_1$  and  $Z_2$  respectively, despite the phase-angle effects. The circuit of Figure 3 is designed to be independent of fluctuations of the supply voltage  $E$ , so that, as the frequency is varied, such fluctuations are not confused with the effect of changes of  $Z$ . Although both rectifiers are working over those portions of their characteristics normally considered straight, their very slight non-linearity necessitates that  $E$  should still be maintained within fairly close limits if precision measurements are required.

In the instrument to be described here, great constancy of output voltage is achieved by means of an amplified feedback system. A high oscillator voltage is provided to ensure that both rectifiers work over an approximately linear portion of their characteristics even for the lowest values of  $Z$ . In the following sections, the circuit design is discussed in detail.

### 1. Oscillator and Power Amplifier

The main requirements of the source of radio-frequency power are firstly, constancy of amplitude over a wide frequency range and for all possible loading conditions; secondly, good short-term frequency stability. The first of these features has been achieved by the use of amplified direct-current feedback and the second by careful choice of oscillator components.

As may be seen in Figure 4, a tuned-anode pentode amplifier with inductive feedback is used as a master oscillator feeding a power amplifier. Frequencies from 5 to 30 megacycles per second are covered in three ranges by pairs of plug-in coils, tuned by ganged capacitors. The coils are of the metallized ceramic type mounted in screening cans. The screen-grid potential of the oscillator provides a flexible and convenient amplitude control fed by the amplified feedback voltage. This voltage is derived by a crystal rectifier across the input to the radio-frequency potential-dividing network described in Section 3. The difference between direct voltage obtained in this manner and a fixed reference potential is applied to the input of an amplifier and cathode-follower which together constitute a direct-current amplifier of high gain and low output impedance. The overall voltage gain is 550 and, since the feedback system utilises only the difference between the rectified radio-frequency potential and the

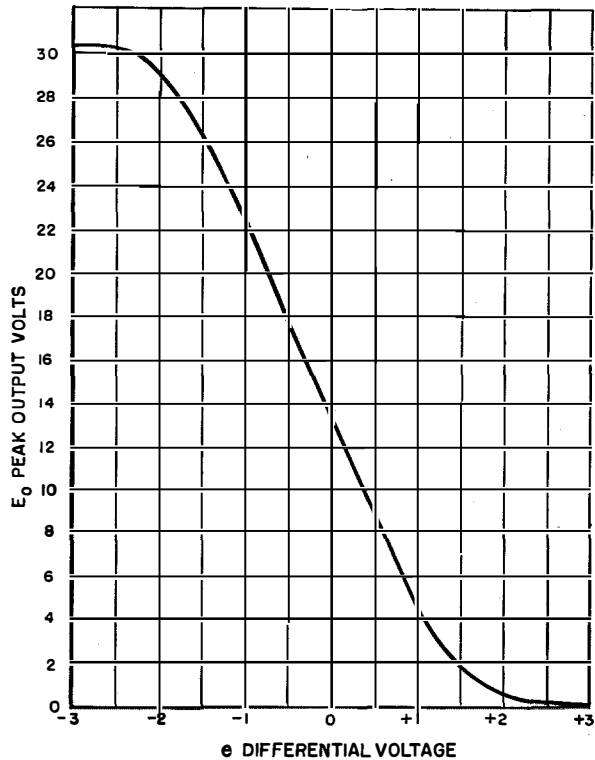

Figure 5—Overall amplitude-control characteristic of oscillator, power amplifier, and feedback amplifier.  $E_0$  is the output peak volts into a 150-ohm load and  $e$  is the differential voltage applied to the feedback amplifier.

direct-current reference potential, it is clear that the gain stability of the amplifier is not of first importance. In Figure 5 the radio-frequency voltage output is shown in terms of the differential voltage applied to the feedback line. In operation, the radio-frequency output is maintained at 11 volts peak at all frequencies and loadings, the requisite sensitivity being obtained under these conditions.

## 2. Detector Circuit

The basic circuit of Figure 3 is elaborated to the circuits of Figures 4 and 6. All the radio-frequency components included in the radio-frequency potential divider of Figure 6 are mounted in a probe, which is directly connected to the cable under test. The test set and probe are shown in Figure 7.

The rectified voltage from the probe passes to the direct-current potential-divider network in Figure 6, which may be conveniently remote from the probe. A direct-current amplifier and meter,

shown at the right in Figure 6, comprises the detector.

The potential divider  $r$  of Figure 3 is thus made up of the resistances  $R3$ ,  $R4$ , and  $R5$  of Figure 6, which are contained in the probe, and the remainder of the network in the test set.

## 3. Radio-Frequency Potential Divider

In the radio-frequency potential-divider circuit of Figure 6, a radio-frequency voltage  $E_0$  is applied to the resistance  $R1$  in series with the cable on test. Capacitors  $C1$  and  $C2$ , together with the resistances  $R2$  and  $R3$  and crystal rectifier  $X1$ , comprise a network that produces a direct voltage between the lead  $D$  and earth, proportional to the peak value of  $E_0$ . It is this voltage that is used in the automatic-amplitude-control system and, since  $C1$  may be connected to measure  $E_0$  at the point where voltage is applied to resistance  $R1$ , the line from the oscillator unit may be made as long as desired without introducing error.

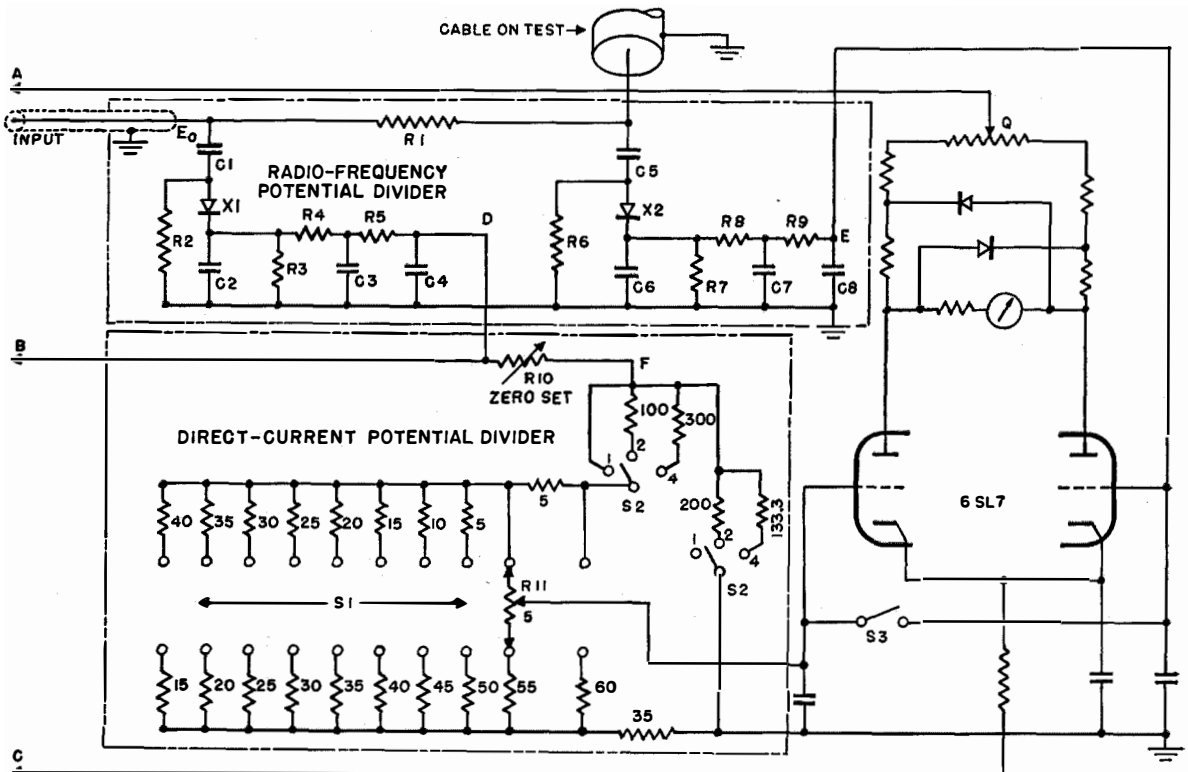

Figure 6—The radio-frequency equipment within the rectangle designated "Radio-Frequency Potential Divider" is mounted in the probe. Rectification being accomplished in the probe, the "Direct-Current Potential Divider" may be mounted conveniently at a distance from the probe. The values of the resistors in the potentiometer are indicated in thousands of ohms. The 6SL7 direct-current amplifier and meter at the right comprise the detector.

An identical network consisting of  $C5$ ,  $C6$ ,  $R6$ ,  $R7$ , and  $X2$ , serves to measure the peak voltage across the cable.

The network  $R4$ ,  $R5$ ,  $C3$ , and  $C4$  constitutes a two-stage radio-frequency filter as does  $R8$ ,  $R9$ ,  $C7$ , and  $C8$ . These two filters are made as similar as sensitivity considerations will allow. The two rectifier networks are, therefore, substantially identical, and any relative frequency effects on their characteristics will be minimized. A convenient feature is that the voltages appearing at the terminals  $D$  and  $E$  are effectively isolated from the radio-frequency circuits by the filters, and contain only direct-current components. These direct voltages are conducted from the probe to the remainder of the apparatus by a flexible cable containing a coaxial line for the radio-frequency supply and two shielded wires for the direct current.

by calibration. The total resistance from the point  $F$  to earth by a path not including the source of direct current is constant for all positions of the ganged switch  $S1$ . It is clear that the voltage across  $R11$  is a fixed portion of the direct-current input. For the values shown in the figure this voltage is:—

**4. Direct-Current Potential Divider**

The direct-current potential appearing at point  $D$  in Figure 6, besides being used as already described for automatic-control purposes, is also applied to the direct-current potential divider. This network, combined with resistances  $R3$ ,  $R4$ , and  $R5$  enables a voltage ratio of 8 (corresponding to impedances of from 10 ohms to 500 ohms) to be covered continuously by means of two dials and a range switch. The fine dial has a continuous range of 0–0.1, the coarse dial switches from 1 to 1.9 in steps of 0.1, and the range switch  $S5$  divides by 1, 2, or 4. The calibration of the fine dial is independent of the coarse-dial setting and the complete range from 0.25 to 2 may, therefore, be covered with high accuracy. The numbers mentioned here indicate relative voltages only but may be interpreted directly as impedances

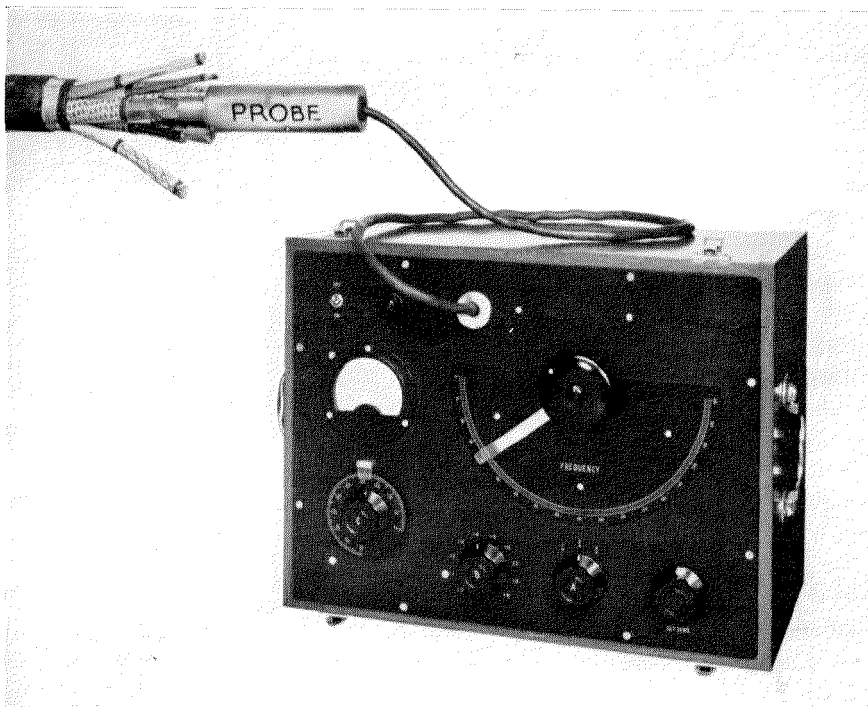

Figure 7—Test set showing manner of making connection to the cable under test by means of a probe in which all radio-frequency components of the test equipment are mounted.

by calibration. The total resistance from the point  $F$  to earth by a path not including the source of direct current is constant for all positions of the ganged switch  $S1$ . It is clear that the voltage across  $R11$  is a fixed portion of the direct-current input. For the values shown in the figure this voltage is:—

$$\frac{(\text{Direct-Current Input}) \times 5000}{100,000 + R10}$$

when  $S2$  is in position 1. In practice,  $R10$  is used to set the zero of the instrument as subsequently described.  $S2$  is designed to change the range of the potential divider without altering its input impedance.

**5. Balance Indicator**

To facilitate effective wide-range filtering, a high-impedance detector is desirable and a sensitivity of a few hundred microamperes per volt would comfortably permit balance to within 0.1 per cent on a robust moving-coil meter. An electronic meter stage is a logical choice. The detector shown to the right of Figure 6 utilises a double-triode valve connected in the form



commonly known as a "long-tailed pair" and having a 25-0-25-microampere meter connected between the anodes. The cathode resistance is common to both valves and has an ohmic value large compared with all the other resistances in the circuit. It is clear that variations affecting both valves in parallel, e.g., high-tension variations, heater fluctuations, etc., will encounter almost 100-per-cent feedback whilst signals impressed on the grid are amplified in push-pull by virtue of the cathode coupling. The sensitivity obtained is 700 microamperes per volt and a balance will be maintained indefinitely when the circuit has warmed up.

To prevent damage by overload, two biased crystal rectifiers are connected across the meter and a resistance in series. A sharp cut off is obtained just beyond full-scale deflection which entirely prevents harm to the instrument without distortion of the scale shape. The voltage divider  $Q$  is used to balance the detector with button switch  $S3$  depressed.

### 6. Effect of Stray Impedances in Radio-Frequency Potential Divider

Stray impedances will include those unavoidably present due to physical limitations of the layout and also those undesirably but necessarily introduced as part of the measuring technique. Consideration of Figure 6 shows that impedances across the input side of the network, that is, the side remote from the cable, fall across the oscillator and are of no consequence. The series resistor  $R1$  is of the high-stability tubular carbon type and is mounted as the central conductor of a coaxial line. The distributed inductance and capacitance associated with this item cause a phase angle which, although minute, can be shown to have a noticeable effect on precision measurements. The remaining effect is that of the rectifier network across the cable and is most easily analysed by a graphical method.

In Figure 8 each circle represents the locus of an admittance vector of origin  $O$  for a cable having a selected value of total attenuation, i.e., the product of attenuation constant times length. If a susceptance is placed across the cable, the new locus can be obtained by displacing the origin along the ordinate axis to say  $O'$  (exaggerated). The rectifier network will then give minimum

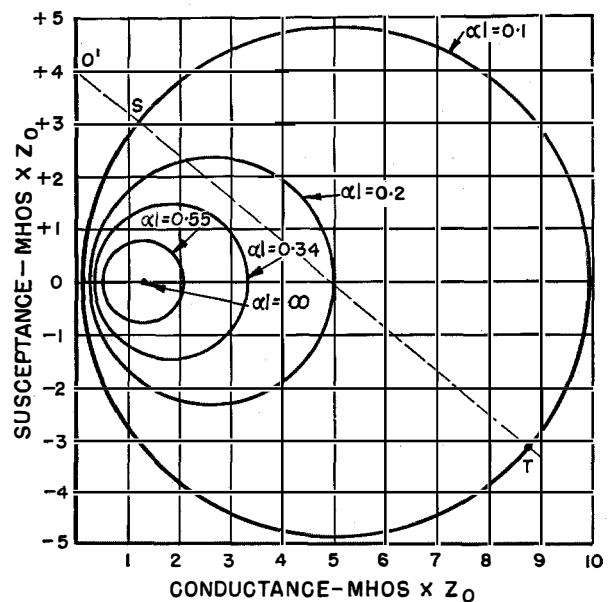

Figure 8—Admittance circle diagrams for cables having various values of attenuation  $\alpha l$ .

and maximum outputs corresponding to  $O'T$ ,  $O'S$  respectively if we neglect the small correction due to the effect of phase angle on the voltage distribution between  $R1$  and the cable. The addition of a conductance term will move the origin to the left.

It is clear that small susceptances are closely cancelled by slight retuning but that conductances are directly additive. There is evidently a difference in the voltage obtained across a cable of a given resistive impedance and that which would be obtained using a resistor of equal magnitude, since in the latter case there is no tuning of the stray reactances.

### 7. Impedance Calibration

Initial calibration is circumscribed by available apparatus and the difficulties arising out of stray reactances discussed above. The ideal calibrator would be a long length of uniform cable having accurately known constants. Such a calibration would at once remove all errors due to stray reactances, but practical cables are not sufficiently uniform to permit accurate calculations over a range from 10 to 500 ohms. Instead, a procedure was adopted permitting the use of a tuned circuit and resistance in the place of the cable.

In Figure 9,  $R1$  is, as before, the series resistor;  $R2$ ,  $C1$  represent the effective resistance and capacitance of the rectifier network;  $RD$  represents the dynamic impedance of a tuned circuit comprised of  $L2$ ,  $C2$ , and strays;  $R3$  is a special type of high-frequency resistor. In practice, it is not possible to connect the tuned circuit across  $R2$  without some inductance (represented by  $L1$ ) but the effect may be minimised by the use of a very short coaxial line having a diameter ratio close to unity.

The frequency of the oscillator is set at 5 megacycles, and  $R3$  is 500 ohms.  $C2$  is adjusted to give a maximum voltage across the rectifier network. Different values for  $R3$  are then inserted without re-adjustment of  $C2$  and the voltage measured for each value of  $R3$ . A calibration curve is plotted showing volts obtained for effective resistance  $R'$ , where  $R'$  is the resistance of  $R3$  in parallel with  $RD$ . The process is repeated at points throughout the frequency range and a family of curves obtained as given in Figure 10.

The dispersion occurring at the low-resistance end of the curves is consistent with the presence of a small inductance  $L1$  which, it may be emphasised, causes no dispersion when cables are being tested. The true calibration curves therefore require correction for this inductance and the result is a frequency-independent calibration substantially coincident with that measured at 5 megacycles. In the absence of any frequency effects, the shape of the impedance-voltage characteristic can be easily calculated. If allowance is made for a small change in  $R2$  with voltage, the calculated values may be shown to correspond precisely with the calibration curve. This is particularly useful as a check on the calibration for small impedances.

Cable impedances close to 75 ohms may be accurately measured by available apparatus. A

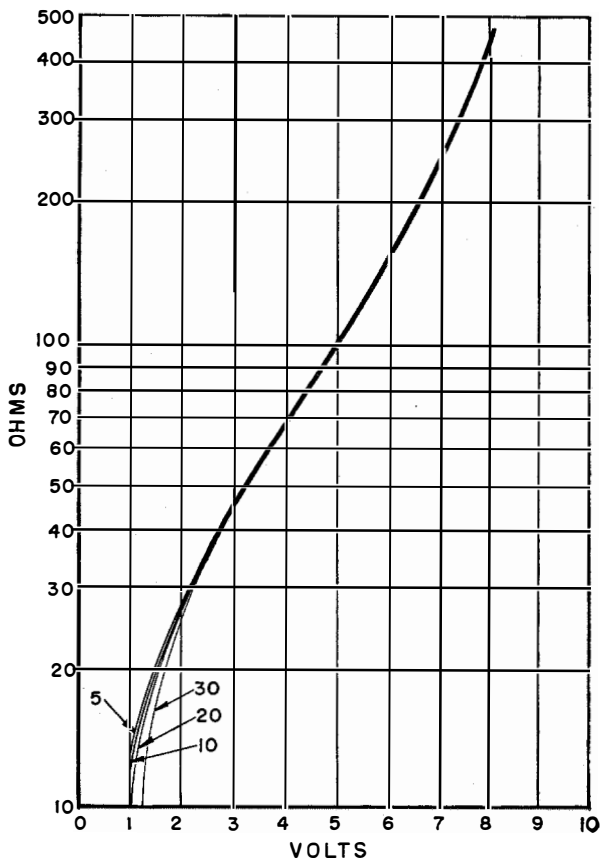

Figure 10—Uncorrected impedance-frequency calibration curves. The frequencies in megacycles are indicated for the several branches of the curves at low voltages.

comparison was therefore undertaken with the dual purpose of cross-checking the calibration at these values and obtaining precise values for the resistor used in setting up. Agreement was reached within 0.1 per cent. The stability is affected by three factors.

- A. Change in oscillator amplitude due to variation in battery potential, ageing of valves, etc.
- B. Change in current through the direct-current potential dividers due to variations in rectifier efficiency.
- C. Variations of the value of the series resistor  $R1$  due to temperature, humidity, ageing, mechanical shocks, etc.

Items *A* and *B* will effectively multiply the calibration curve by a constant factor whilst item *C* will both multiply the calibration curve and distort the shape. It is clear that, if the curve could be moved to coincide with the original calibration at some selected point, a smaller error would in general arise, being actually zero at the

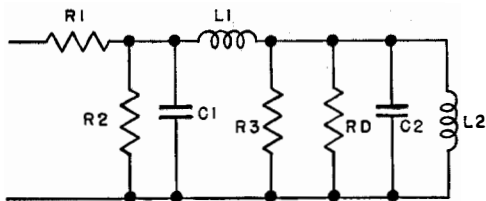

Figure 9—Simplified equivalent circuit for calibration using a resistance and tuned circuit.

point of intersection. Now, in this apparatus, which is to be used exclusively for cables having a characteristic impedance close to 75 ohms, the impedance excursions are geometrically centred at 75 ohms. The action of "setting zero" has, therefore, been arranged to bring the 75-ohm points into coincidence, and it follows that in evaluation of  $Z_0$  from the formula  $Z_0 = (Z_1 Z_2)^{\frac{1}{2}}$  the characteristic impedance is obtained with high accuracy even with appreciable change in specific points on the calibration curve.

The foregoing discussion has been conducted solely in terms of the fundamental test frequency without reference to the effect of harmonics. It is shown in Section 11.4 of the appendix that under certain conditions harmonics can greatly influence the results and that a calibration in terms of purely resistive loads is not valid except for impedances close to the characteristic impedance of the cable. For precision measurements on cables presenting a wide impedance swing, comparison must be made with a cable of known characteristics. This is not generally a disadvantage since tests on short lengths of cable are usually more concerned with detection of non-uniformity of manufacture than with absolute measurements of characteristics.

### 8. Frequency Calibration

The radio-frequency probe was coupled to a wavemeter by means of a single turn of copper wire and, at intervals of 5 degrees on the frequency dial, the frequency was measured with an accuracy of approximately 0.1 per cent. This is adequate for the main frequency setting, but

it is necessary for determination of the phase constant to measure small changes of frequency that cannot reasonably be taken from the main frequency calibration. An additional curve has therefore been plotted for each of the three frequency ranges showing the slope of the frequency curve in kilocycles per degree at any chosen mean frequency.

### 9. Accuracy of Measurements

Complete specification of the accuracy obtained is not practicable since it depends to some extent on the length and attenuation of the cable to be measured, but it may be claimed that the characteristic impedance of a cable may be determined to within 0.1 per cent whilst the attenuation constant may be measured with in general slightly lower accuracy. Measurement of  $\beta$  is so dependent on the length of the cable under test that no useful estimate may be given but, as a guide, it may be stated that frequency increments ranging from 1 to 17 kilocycles are discernable, according to frequency.

### 10. Measurement Procedure

To determine  $Z_1$ ,  $Z_2$ , and  $\delta f$ , the following test procedure is adopted:—

- A. Coils are inserted according to the frequency range in which measurements are to be made.
- B. The frequency dial is set to the required frequency.
- C. The amplitude dials are set to the position given on the calibration graph.
- D. With the calibrator plugged into the probe, the "set zero" is adjusted to obtain balance. Balance is achieved when depression of  $S3$  causes no change of meter reading.

TABLE 1

$R(Z_T)$	Characteristic Impedance $Z_0$ in Ohms	Attenuation Constant $\alpha$ in Decibels/Mile	Phase Constant $\beta$ in Radians/Mile	Velocity Ratio $v/c$
$\infty^*$	$(Z_1 Z_2)^{\frac{1}{2}}$	$\frac{8 \cdot 686}{L} \tanh^{-1} \left( \frac{Z_1}{Z_2} \right)^{\frac{1}{2}}$	$\frac{\pi f}{L \delta f}$	$\frac{2L \delta f}{c}$
0	$(Z_1 Z_2)^{\frac{1}{2}}$	$\frac{8 \cdot 686}{L} \tanh^{-1} \left( \frac{Z_1}{Z_2} \right)^{\frac{1}{2}}$	$\frac{\pi f}{L \delta f}$	$\frac{2L \delta f}{c}$
$> Z_0^*$	$(Z_1 Z_2)^{\frac{1}{2}}$	$\frac{8 \cdot 686}{L} \left[ \tanh^{-1} \left( \frac{Z_1}{Z_2} \right)^{\frac{1}{2}} - \coth^{-1} \left( \frac{Z_T}{Z_0} \right) \right]$	$\frac{\pi f}{L \delta f}$	$\frac{2L \delta f}{c}$
$< Z_0$	$(Z_1 Z_2)^{\frac{1}{2}}$	$\frac{8 \cdot 686}{L} \left[ \tanh^{-1} \left( \frac{Z_1}{Z_2} \right)^{\frac{1}{2}} \tanh^{-1} \left( \frac{Z_T}{Z_0} \right) \right]$	$\frac{\pi f}{L \delta f}$	$\frac{2L \delta f}{c}$

\* Not recommended (see appendix).

E. The cable is connected and the oscillator retuned slightly to obtain a maximum and minimum; values of  $Z_1$  and  $Z_2$  being noted. The cable must be terminated if  $Z_1$  or  $Z_2$  are outside the range of the set. (See Section 11.1 of the appendix.)

F. The frequency is varied over small increments on either side of the principal setting and the separation measured between a convenient number of impedance peaks of the same sign. Thus, let the total frequency difference read from the incremental frequency graph be  $f'$  for  $n$  peaks, then the mean separation between two adjacent peaks is given by:—

$$\delta f = f'/n.$$

$Z_0$ ,  $\alpha$ ,  $\beta$ , or  $v/c$  may then be determined by substitution in the relevant formulae of Table 1. The cable length is here expressed in miles and  $c = 186,280$  miles per second.

## 11. Appendixes

### 11.1 SYMBOLS

$Z_0$  = characteristic impedance

$Z$  = impedance of cable (sending end)

$|Z|$  = modulus of  $Z$

$Z_2$  = maximum value of  $|Z|$

$Z_1$  = minimum value of  $|Z|$

$Z_T$  = terminating impedance

$R(Z_T)$  = resistive component of  $Z_T$

$\alpha$  = attenuation constant

$\lambda$  = wavelength in cable

$\beta$  = phase constant =  $2\pi/\lambda$

$v$  = velocity of wave in cable

$c$  = velocity of light in vacuo

$L$  = physical length of cable

$f$  = frequency

$\delta f$  = frequency increment between two adjacent impedance peaks of the same sign.

### 11.2 $Z_0$ , $\alpha$ , $\beta$ , AND $v/c$

In this appendix, the equation for the sending-end impedance of a cable under various conditions of termination is examined and manipulated to show how  $Z_0$ ,  $\alpha$ ,  $\beta$ , and  $v/c$  may be deduced from the purely resistive measurements  $Z_1$  and  $Z_2$  together with the frequency measurement  $\delta f$ .

The general equation<sup>3</sup> giving the sending-end impedance of a cable terminated at its far end by  $Z_T$  is:—

$$Z = \frac{Z_T + Z_0 \tanh(\alpha + j\beta)L}{1 + \frac{Z_T}{Z_0} \tanh(\alpha + j\beta)L}. \quad (1)$$

This may be simplified for the following four specific cases.

#### 11.2.1 Case 1, Cable Open-Circuited at Far End

By substituting  $Z_T = \infty$  in (1), we obtain

$$Z = Z_0 \coth(\alpha + j\beta)L, \quad (2)$$

and expanding

$$= Z_0 \frac{\cosh \alpha L \cos \beta L + j \sinh \alpha L \sin \beta L}{\sinh \alpha L \cos \beta L + j \cosh \alpha L \sin \beta L},$$

and rationalising

$$= \frac{Z_0 \sinh 2\alpha L + j \sin 2\beta L}{2 \cosh^2 \alpha L - \cos^2 \beta L}. \quad (3)$$

In this equation, the attenuation constant  $\alpha$  is a function primarily of the geometry and physical form of the cable and, although it varies with  $f^{\frac{1}{2}}$  it may be assigned fixed values over small frequency changes. The phase constant  $\beta = 2\pi/\lambda = (2\pi f)/v$  varies almost directly with frequency and is, therefore, the term responsible for the frequency characteristic of cable impedance. If fixed values are assigned to  $\alpha L$ , and  $Z$  is plotted in the complex plane as a function of  $\beta L$ , a family of circles is obtained representing the impedance loci. Alternatively, if  $1/Z$  is plotted as a function of  $\beta L$  the family of circles obtained represents the admittance loci. A typical set of characteristics is shown in Figure 8 from which it will be noticed that each circle has a diameter along the real axis. As the frequency is varied, the impedance modulus swings to and fro between extreme values represented by the ends of the diameter on the real axis and traces out the typical impedance-frequency characteristic of Figure 1. It is important to notice that  $Z_1$  and  $Z_2$  of Figure 1 correspond to purely resistive points on the circle diagrams.

Now the minimum value of  $|Z|$  occurs when  $\beta L = (2n+1)\pi/2$  in which case (3) reduces to:—

$$Z_1 = Z_0 \tanh \alpha L. \quad (4)$$

Similarly  $|Z|$  is a maximum when  $\beta L = n\pi$ , then

$$Z_2 = Z_0 \coth \alpha L. \quad (5)$$

By multiplication of (4) and (5), we obtain:—

$$Z_1 \cdot Z_2 = Z_0^2$$

or

$$Z_0 = (Z_1 \cdot Z_2)^{\frac{1}{2}}. \quad (6)$$

It follows from (4) that

$$\tanh \alpha L = \frac{Z_1}{Z_0} = (Z_1/Z_2)^{\frac{1}{2}}$$

or

$$\alpha = \frac{1}{L} \tanh^{-1} \left( \frac{Z_1}{Z_2} \right)^{\frac{1}{2}}. \quad (7)$$

By use of (6) and (7), therefore,  $Z_0$  and  $\alpha$  may be determined from the measurements of  $Z_1$  and  $Z_2$ .

The phase constant  $\beta$  is defined as  $2\pi/\lambda$ , but since  $\lambda = v/f$  it may be expressed more conveniently as:—

$$\beta = \frac{2\pi f}{v}. \quad (8)$$

Now, it is clear from Figure 8 that the change in  $\beta L$  for successive maxima or minima of  $Z$  is  $\pi$ . Hence, change in

$$\beta L = \frac{2\pi \delta f L}{v} = \pi, \quad (9)$$

whence

$$v = 2L\delta f. \quad (10)$$

Substituting this value for  $v$  in (8), we have

$$\beta = \frac{\pi f}{L\delta f}. \quad (11)$$

Also from (10)

$$\frac{v}{c} = \frac{2L\delta f}{c}. \quad (12)$$

The phase constant and velocity ratio may thus be deduced from measurements of  $\delta f$  and knowledge of  $L$  and  $f$ .

All of the required cable parameters may, therefore, be determined from measurements on an open-circuited cable. It is shown in the following section that a short-circuited cable will give identical results.

### 11.2.2 Case 2, Cable Short Circuited at Far End

By substituting  $Z_T = 0$  in (1), we obtain

$$Z = Z_0 \tanh (\alpha + j\beta)L. \quad (13)$$

Expanding and rationalising as for case 1,

$$Z = \frac{Z_0 \sinh 2\alpha L + j \sin 2\beta L}{2 \frac{\sinh 2\alpha L + \cos^2 \beta L}{2}}, \quad (14)$$

from which

$$Z_1 = Z_0 \tanh \alpha L,$$

occurring when

$$\beta L = n\pi$$

and

$$Z_2 = Z_0 \coth \alpha L, \quad (15)$$

occurring when

$$\beta L = \frac{(2n+1)\pi}{2}.$$

Equations (6) to (12) may now be deduced precisely as in case 1.

It will be observed from Figure 8 that, as  $\alpha L$  becomes smaller, the difference between  $Z_1$  and  $Z_2$  increases. With short lengths of cable, values of  $Z_1$  and  $Z_2$  may therefore fall outside the practical range of measurement. In such cases, they may be kept within bounds by terminating the cable with an impedance having a known resistive component. This has the effect of virtually increasing  $\alpha L$ . There are two cases to consider, one when  $R(Z_T) > Z_0$  and the second when  $R(Z_T) < Z_0$  but, as in the open- and short-circuited cases, both lead to the same results and similar formulae.

### 11.2.3 Case 3, Cable Terminated by Impedance $Z_T$ Where $R(Z_T) > Z_0$

Put

$$Z_T = Z_0 \coth R_1. \quad (16)$$

By substituting in (1),

$$Z = Z_0 \coth (R_1 + \alpha L + j\beta L). \quad (17)$$

Comparing this equation with (2), it immediately follows that

$$Z_1 = Z_0 \tanh (R_1 + \alpha L), \quad (18)$$

occurring when

$$\beta L = (2n+1)\pi/2.$$

$$Z_2 = Z_0 \coth (R_1 + \alpha L), \quad (19)$$

occurring when

$$\beta L = n\pi.$$

Equations (6), (11), and (12) may be deduced directly from (18) and (19) thus giving the required relationship for  $Z_0$  and  $\beta$ . An expression for  $\alpha$  is deduced from (16) and (18) as follows:—  
From (18)

$$(R_1 + \alpha L) = \tanh^{-1} \frac{Z_1}{Z_0}$$

and from (16)

$$R_1 = \coth^{-1} \frac{Z_T}{Z_0}.$$

Hence

$$\alpha = \frac{1}{L} \left( \tanh^{-1} \frac{Z_1}{Z_0} - \coth^{-1} \frac{Z_T}{Z_0} \right). \quad (20)$$

In the foregoing analysis, it has been tacitly assumed that  $R_1$  is purely real. This is closely true for a resistive termination and moreover, as may be seen from (17), an imaginary component adds a constant to  $\beta L$  which necessitates slight retuning to obtain a maximum but has no effect on the amplitude.

11.2.4 Case 4, Cable Terminated by Impedance  $Z_T$  Where  $R(Z_T) < Z_0$

Put

$$Z_T = Z_0 \tanh R_2. \quad (21)$$

By substitution in (1),

$$Z = Z_0 \tanh (R_2 + \alpha L + j\beta L). \quad (22)$$

By comparison with (13), it follows that:—

$$Z_1 = Z_0 \tanh (R_2 + \alpha L), \quad (23)$$

occurring when

$$\beta L = n\pi.$$

$$Z_2 = Z_0 \coth (R_2 + \alpha L), \quad (24)$$

occurring when

$$\beta L = (2n + 1)\pi/2.$$

As in case 3, (6), (11), and (12) may be deduced from (23) and (24) while  $\alpha$  may be obtained thus:—

From (23),

$$(R_2 + \alpha L) = \tanh^{-1} \frac{Z_1}{Z_0}.$$

From (21),

$$R_2 = \tanh^{-1} \frac{Z_T}{Z_0}.$$

Hence

$$\alpha = \frac{1}{L} \left( \tanh^{-1} \frac{Z_1}{Z_0} - \tanh^{-1} \frac{Z_T}{Z_0} \right). \quad (25)$$

In the foregoing, impedances are expressed in ohms,  $\beta$  in radians per unit length, and  $\alpha$  in nepers per unit length. Conversion of nepers to decibels is effected by the formula:—

$$\text{Decibels} = 8.686 \times \text{Nepers}.$$

A summary of the results obtained from the four cases discussed is given in Table 1.

11.3 EFFECT OF PHASE ANGLE ON LOCATION OF  $Z_1$  AND  $Z_2$

It has been pointed out in the introduction that in the circuit of Figure 2 the measured value of  $e$  will not correspond exactly with the characteristic of Figure 1 for all values of  $|Z|$  since the value of  $e$  is dependent on the phase angle as well as the modulus of  $Z$ . The effect of the phase angle must therefore be investigated in so far as it may mask the determination of the purely resistive values  $Z_1$  and  $Z_2$ . As shown in Figure 11, the

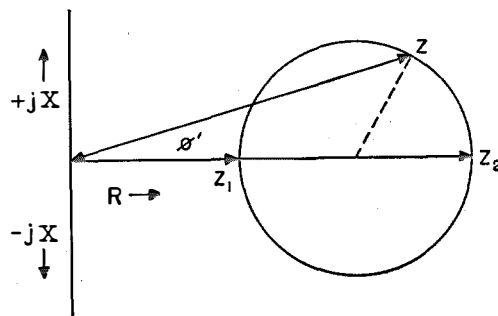

Figure 11—Impedance locus of a coaxial cable.

impedance locus of a cable is a circle between the minimum value  $Z_1$  and the maximum  $Z_2$ . Now in the circuit of Figure 2, the voltage ratio  $e/E$  may be expressed in terms of  $R$  and  $Z$  by:—

$$\frac{e}{E} = \left| \frac{Z}{R+Z} \right|. \quad (26)$$

As the impedance vector  $Z$  moves away from its minimum  $Z_1$ , both its magnitude and phase angle

are increasing. Each of these factors will increase the ratio  $e/E$  in (26). The effect of the phase-angle will, therefore, be to sharpen the lower peaks of Figure 1 and assist in the precise location of  $Z_1$ . In the vicinity of the maximum, however, the modulus of  $Z$  increases as the phase angle becomes smaller and vice versa. The two factors are now in opposition. If the modulus change predominates, the only result will be to flatten the maximum values of Figure 1 but if the phase-angle change is the greater, a double hump will occur in the characteristic. The flattening of the curve is of no consequence since it does not give rise to error in the evaluation of  $Z_2$ , and  $\delta f$  may conveniently be assessed from the sharp minimum values. It is now shown in this appendix that the double-hump effect cannot occur when measuring cables.

Referring to (26), the impedance  $Z$  may be expressed as:—

$$Z = |Z| \cos \phi + j |Z| \sin \phi,$$

$$\therefore \frac{Z}{R+Z} = \frac{|Z| \cos \phi + j |Z| \sin \phi}{R + |Z| \cos \phi + j |Z| \sin \phi}. \quad (27)$$

Rationalising,

$$\frac{Z}{R+Z} = \frac{|Z|^2 + |Z| \cdot R \cos \phi + j |Z| \cdot R \sin \phi}{R^2 + 2|Z| \cdot R \cos \phi + |Z|^2}, \quad (28)$$

hence

$$\left| \frac{Z}{R+Z} \right| = \frac{Z}{(R^2 + 2|Z| \cdot R \cos \phi + |Z|^2)^{\frac{1}{2}}}. \quad (29)$$

Substituting for  $\left| \frac{Z}{R+Z} \right|$  from (26) and re-writing for  $\cos \phi$ , we have:—

$$\cos \phi = \frac{|Z|^2 \left( \frac{E^2}{e^2} - 1 \right) - R^2}{2|Z| \cdot R}. \quad (30)$$

Now  $R$  and  $E$  are fixed, but there are an infinite number of combinations of  $\phi$  and  $Z$  that will satisfy the equation for a given value of  $e$ . We require to discover whether voltages can be obtained that are equal to or greater than those given at the points  $Z_2$ . When  $|Z| = Z_2$ , we have by inversion of (26)

$$\frac{E}{e} = \frac{R+Z_2}{Z_2}.$$

Substituting this value in (30),

$$\cos \phi = \frac{|Z|^2 \left( \frac{R^2 + 2RZ_2}{Z_2^2} \right) - R^2}{2 \cdot |Z| \cdot R}$$

$$= \frac{|Z|^2 \cdot (R + 2Z_2) - Z_2^2 R}{2Z_2^2 \cdot |Z|}. \quad (31)$$

This equation relates the values of  $\phi$  and  $Z$  that would produce a voltage equal to that obtained at  $Z_2$  and which would, therefore, cause a perfectly flat response. If, for any given values of  $Z$ , the phase angle is greater than that prescribed in (31), a double hump will result.

Now in Figure 11 the radius of the circle is clearly  $(Z_2 - Z_1)/2$  and by use of the cosine rule the phase angle  $\phi'$  may be expressed:—

$$\cos \phi' = \frac{|Z|^2 + Z_1 \cdot Z_2}{|Z| (Z_1 + Z_2)}.$$

But

$$Z_1 = \frac{Z_0^2}{Z_2}$$

so that,

$$\cos \phi' = \frac{Z_2 (|Z|^2 + Z_0^2)}{|Z| (Z_2^2 + Z_0^2)}. \quad (32)$$

For the condition  $\cos \phi' > \cos \phi$  we have, therefore,

$$\frac{Z_2 (|Z|^2 + Z_0^2)}{|Z| (Z_2^2 + Z_0^2)} > \frac{|Z|^2 (R + 2Z_2) - Z_2^2 R}{2Z_2^2 \cdot |Z|}$$

or  $|Z|^2 > Z_2^2$ ,

i.e.,  $|Z| > Z_2$ .

But, by definition,  $Z_2$  is the maximum value of  $|Z|$  so that in no case can  $\cos \phi'$  be greater than  $\cos \phi$  and a double hump result.

#### 11.4 EFFECT OF HARMONICS

The maximum error arising in an aperiodic measuring circuit due to the presence of harmonics might normally be considered as being equal to the percentage harmonic distortion present in the source of radio-frequency power but, in the case of coaxial cables, the harmonics receive selective treatment that may in some circumstances either reduce or greatly magnify the normally expected error.

Throughout this equipment all radio-frequency voltages are measured in terms of positive-going

peaks. The effective oscillator output may be represented by the infinite series:—

$$\sum V_n = V_1 + V_2 + V_3 + \dots$$

Here  $V_n$  represents the effective amplitude of the  $n$ th harmonic. The word “effective” is used here to refer to that component of the harmonic that affects the peak value of the composite wave and may be positive or negative.

In the circuit of Figure 2, having a resistive load equal to  $P$ , the voltage  $e$  across the load is given by:—

$$e = \frac{P}{R+P} \cdot \sum V_n \tag{33}$$

Now, in the case of a cable, the impedance  $Z$  has a value dependent on frequency (and therefore on  $n$ ) and we may write:—

$$e = \sum \left[ \frac{Zf(n)}{R+Z \cdot f(n)} \cdot V_n \right] \tag{34}$$

It is shown in Section 11.2 that maximum and minimum values of  $Z$  occur when either  $\beta L = m\pi$  or  $(2m+1)\pi/2$ , where  $m$  is any integer.

Since  $\beta$  varies almost directly with frequency, we may write:—

$$\beta n = n\beta_1 \tag{35}$$

where  $n$  is the order of the harmonic.

In general, therefore, if

$$\beta_1 L = m\pi,$$

then

$$\beta_n L = nm\pi.$$

Similarly, if

$$\beta_1 L = (2m+1)\pi/2$$

then

$$\beta_n L = (2m+1)n\pi/2.$$

Now, so long as  $\beta_n L = nm\pi$ , the cable condition is identical for all harmonics, e.g., in the open-circuit case, from (5),  $Z_2 = Z_0 \coth \alpha_n L$  for all harmonics, and similarly, in the short-circuit case, from (14),  $Z_1 = Z_0 \tanh \alpha_n L$  for all harmonics.

When  $\beta_n L = (2m+1)n\pi/2$  however, a reversal takes place if  $n$  is even, so that the cable presents a maximum impedance to the fundamental and odd harmonics, and a minimum impedance to even harmonics, or vice versa.

It is clear that for cables where the impedance excursion  $Z_1$  to  $Z_2$  is small, there can be little discrimination between fundamental and harmonics and no appreciable error is likely to arise. The following analysis therefore considers only the extreme cases where  $Z_0 \coth \alpha L > Z_0 > Z_0 \tanh \alpha L$  so that unity is taken as inconsiderable compared with  $\coth \alpha L$  but large compared with  $\tanh \alpha L$ . Also, for the sake of simplicity,  $R$  is taken as being equal in value to  $Z_0$ .

On these assumptions the four specific terminating conditions examined in Section 11.2 can now be investigated.

#### 11.4.1 Case 1, Cable Open Circuited

##### 11.4.1.1 Case 1A, When $\alpha L = (2m+1)\pi/2$

When  $\alpha L = (2m+1)\pi/2$ , from (4),

$$Z_1 = Z_0 \tanh \alpha L.$$

Substituting this value in (34) and noting that in practice the attenuation constant  $\alpha$  varies as  $f^{1/2}$  so that  $\alpha_n = n^{1/2} \cdot \alpha$ , we may write:—

$$e = \underbrace{\sum \frac{Z_0 \tanh n^{1/2} \alpha L}{R + Z_0 \tanh n^{1/2} \alpha L} \cdot V_n}_{n \text{ odd}} + \underbrace{\sum \frac{Z_0 \coth n^{1/2} \alpha L}{R + Z_0 \coth n^{1/2} \alpha L} \cdot V_n}_{n \text{ even}}$$

Now bearing in mind the assumption that  $Z_0 = R$  and that  $Z_0 \tanh \alpha L < Z_0 < Z_0 \coth \alpha L$ , this equation reduces to:—

$$e = \underbrace{\sum (\tanh n^{1/2} \alpha L) \cdot V_n}_{n \text{ odd}} + \underbrace{\sum V_n}_{n \text{ even}} \tag{36}$$

This reveals that the effective amplitude of the odd harmonics is multiplied, relative to the fundamental, by a term:—  $\tanh n^{1/2} \alpha L / \tanh \alpha L$ , whilst the even harmonics are multiplied by  $\coth \alpha L$ . If these terms were unity there would be no error and any departure from unity is accordingly a measure of the error introduced by the presence of the harmonics. The first of these terms is always  $> 1$ , and for small values of  $\alpha L$  is approximately equal to  $n^{1/2}$ . The second term is  $\gg 1$  by hypothesis. When the cable is open circuited, therefore, values of  $Z_1$  may be in serious error if  $Z_1$  is very different from  $Z_0$ .



11.4.1.2 Case 1B, When  $\beta L = m\pi$

When  $\beta L = m\pi$ , from (5)

$$Z_2 = Z_0 \coth \alpha L,$$

$$e = \sum \underbrace{\frac{Z_0 \coth n^{\frac{1}{2}}\alpha L}{R + Z_0 \coth n^{\frac{1}{2}}\alpha L}}_{n \text{ odd and even}} V_n \div \underbrace{\sum V_n}_{n \text{ odd and even}}$$

Here the multiplying factor is approximately unity for all harmonics and no large error can result. Under open-circuit conditions,  $Z_2$  may thus be measured with accuracy.

11.4.2 Case 2, Cable Short Circuited

11.4.2.1 Case 2A, When  $\beta L = m\pi$

When  $\beta L = m\pi$ , from (14)

$$Z_1 = Z_0 \tanh \alpha L.$$

Proceeding as in case 1,

$$e = \sum \underbrace{\frac{Z_0 \tanh n^{\frac{1}{2}}\alpha L}{R + Z_0 \tanh n^{\frac{1}{2}}\alpha L}}_{n \text{ odd and even}} V_n \div \underbrace{\sum (\tanh n^{\frac{1}{2}}\alpha L) V_n}_{n \text{ odd and even}}$$

The multiplying factor is accordingly  $\tanh n^{\frac{1}{2}}\alpha L / \tanh \alpha L$ , the effect of which is small as already discussed.

11.4.2.2 Case 2B, When  $\beta L = (2m+1)\pi/2$

When  $\beta L = (2m+1)\pi/2$ , from (15)

$$Z_2 = Z_0 \coth \alpha L$$

$$e = \sum \underbrace{\frac{Z_0 \coth n^{\frac{1}{2}}\alpha L}{R + Z_0 \coth n^{\frac{1}{2}}\alpha L}}_{n \text{ odd}} V_n + \sum \underbrace{\frac{Z_0 \tanh n^{\frac{1}{2}}\alpha L}{R + Z_0 \tanh n^{\frac{1}{2}}\alpha L}}_{n \text{ even}} V_n$$

This equation simplifies on approximation to:—

$$e = \sum_{n \text{ odd}} V_n + \sum_{n \text{ even}} (\tanh n^{\frac{1}{2}}\alpha L) V_n$$

and the multiplying factors are seen to be unity and  $\tanh n^{\frac{1}{2}}\alpha L$  for odd and even harmonics respectively. Now  $\tanh n^{\frac{1}{2}}\alpha L$  is always less than unity and cannot therefore cause an error greater than the harmonic distortion actually present in the oscillator output.

It is thus seen that in the short-circuit case, the effect of harmonics on the measurement of either  $Z_1$  or  $Z_2$  is small so that it should always be employed in preference to the open-circuit condition.

11.4.3 Case 3, Cable Terminated by  $Z_T$  Where  $R(Z_T) > Z_0$

11.4.3.1 Case 3A, When  $\beta L = (2m+1)\pi/2$

When  $\beta L = (2m+1)\pi/2$ , from (18)

$$Z_1 = Z_0 \tanh (\alpha L + R_1)$$

so that

$$e = \sum \underbrace{\frac{Z_0 \tanh (n^{\frac{1}{2}}\alpha L + R_1)}{R + Z_0 \tanh (n^{\frac{1}{2}}\alpha L + R_1)}}_{n \text{ odd}} V_n + \sum \underbrace{\frac{Z_0 \coth (n^{\frac{1}{2}}\alpha L + R_1)}{R + Z_0 \coth (n^{\frac{1}{2}}\alpha L + R_1)}}_{n \text{ even}} V_n$$

This is seen to be similar to case 1A, Section 11.4.1.1, except that the multiplying factors are  $\tanh (n^{\frac{1}{2}}\alpha L + R_1) / \tanh (\alpha L + R_1)$  and  $\coth (\alpha L + R_1)$ . Although these values are nearer to unity than for the open-circuit case, unless  $R(Z_T)$  is close to  $Z_0$ , the error in measuring  $Z_1$  is still appreciable.

11.4.3.2 Case 3B, When  $\beta L = m\pi$

When  $\beta L = m\pi$ , from (19)

$$Z_2 = Z_0 \coth (R_1 + \alpha L).$$

As this corresponds exactly with case 1B, Section 11.4.1.2, it follows that  $Z_2$  may be accurately measured under this condition.

11.4.4 Case 4, Cable Terminated by  $Z_T$  Where  $R(Z_T) < Z_0$

This case is completely analogous to case 2 and it can be shown that all multiplying factors tend to unity. It should therefore be employed in preference to case 3.

11.4.5 Conclusion

The foregoing analysis is incomplete in that only extreme cases are considered quantitatively and no attempt has been made to indicate at what values of actual cable impedance the errors

become intolerable under specific cable conditions. This approach is justifiable since it serves adequately to indicate the optimum operating conditions and to show that, even when measuring a wide impedance range, errors can be kept within a limit only slightly removed from the actual percentage harmonic distortion emitted by the oscillator. Of the specific cases examined, 1A and 3A are particularly unsuitable for use when a wide range is anticipated. It is, therefore, recommended that measurements should normally be made on cables which are either short circuited or terminated with an impedance having a resistive component less than  $Z_0$ .

### 11.5 MAINTENANCE

The circuits are in principle very simple and largely self correcting. They may be serviced by conventional technique, but the following notes on the automatic-control system may be of use.

Failure of the automatic control will be in evidence as instability of the impedance readings and random drift of zero settings. A speedy check may be made as follows:—connect a 10-ohm resistor to the probe and a voltmeter to the terminal of the screen supply of the oscillator. After switching on, this point rises almost immediately to about 350 volts and after about half a minute should fall quickly and “lock in” to a

voltage in the range 50 to 300 volts. The frequency dial should now be moved over the whole of the frequency range, in the course of which the screen voltage should smoothly adjust itself to voltages in the above-mentioned range. If at any point the limit of 300 volts is exceeded, the radio-frequency amplifier valve is the most probable source of trouble and should be replaced. If the screen-voltage characteristic is normal, then it is unlikely that the electronic apparatus is at fault.

### 12. Bibliography

1. Bray and Taylor, “Impedance Bridges for Use on Coaxial Cables over the Frequency Range 60 Kilocycles to 40 Megacycles,” Cable Test Report 1448, Part I, General Post Office, London, England.
2. T. I. Jones, “The Measurement of the Characteristics of Concentric Cables at Frequencies Between 1 and 100 Megacycles per Second,” *Journal of the Institution of Electrical Engineers*, v. 89, Part 3, pp. 213–220; December, 1942.
3. Willis Jackson, “High Frequency Transmission Lines,” Methuen and Company, London, and Chemical Publishing Company, New York; 1945.
4. J. H. Evans, “Application of Crystal Rectifiers at Frequencies Up to 10,000 Megacycles,” *Journal of the British Institution of Radio Engineers*, v. 8, pp. 12–121; May–June, 1948.
5. G. W. O. Howe, “Behaviour of High Resistances at High Frequencies,” *Wireless Engineer*, v. 12, pp. 91–295; June, 1935.

## Modification of A.R.I. 5272 Aircraft Radio Set

**T**HE *A.R.I. 5272* very-high-frequency radiotelephone communication set<sup>1</sup> for naval aircraft has been adapted for 10-channel operation in any one of 3 frequency bands, 100–125, 115–145, and 124.5–156 megacycles per second. The corresponding commercial equipment is in two models; the *S.T.R.-9-X* covers the range from 115 to 145 megacycles, and the *S.T.R.-9-X2* tunes from 100 to 125 megacycles. The original equipment provided for 4 radiotelephone channels between 115 and 145 megacycles.

Apart from minor circuit modifications in the highest-frequency unit, design changes have been restricted almost entirely to the apparatus mounted in front of the panel of the main unit,

<sup>1</sup>E. C. Fielding, "Aircraft Radio Communication Set A.R.I. 5272," *Electrical Communication*, v. 25, pp. 244–255; September, 1948.

which can still be accommodated in the mounting tray for the original design.

A new remote-control box incorporates built-in dial lighting and will mount on the same fixing centres as the 4-channel unit. Thus, an existing 4-channel equipment may be replaced by the newer 10-channel apparatus quite simply, the major installation change being the replacement of the cable between the control box and set.

As will be evident from the photographs, the channel-selecting mechanism has been expanded to include slides and cams for 10 settings. The operating principles are unchanged. The crystal panel has been modified to accommodate 10 units of either the new international miniature type or the older 4004 model. Spring-loaded crystal retainers are fitted inside the dust cover of the mechanism.

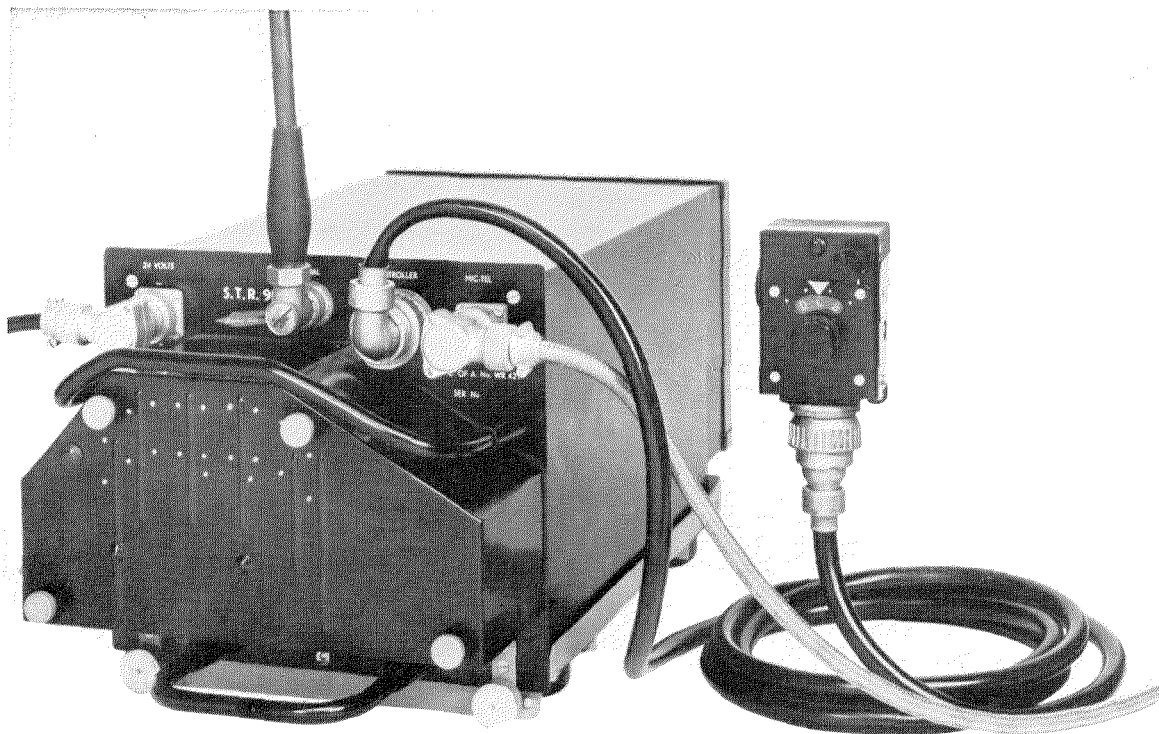

*S.T.R.-9* aircraft radiotelephone set adapted for 10-channel working. The remote-control box incorporates built-in dial lighting.

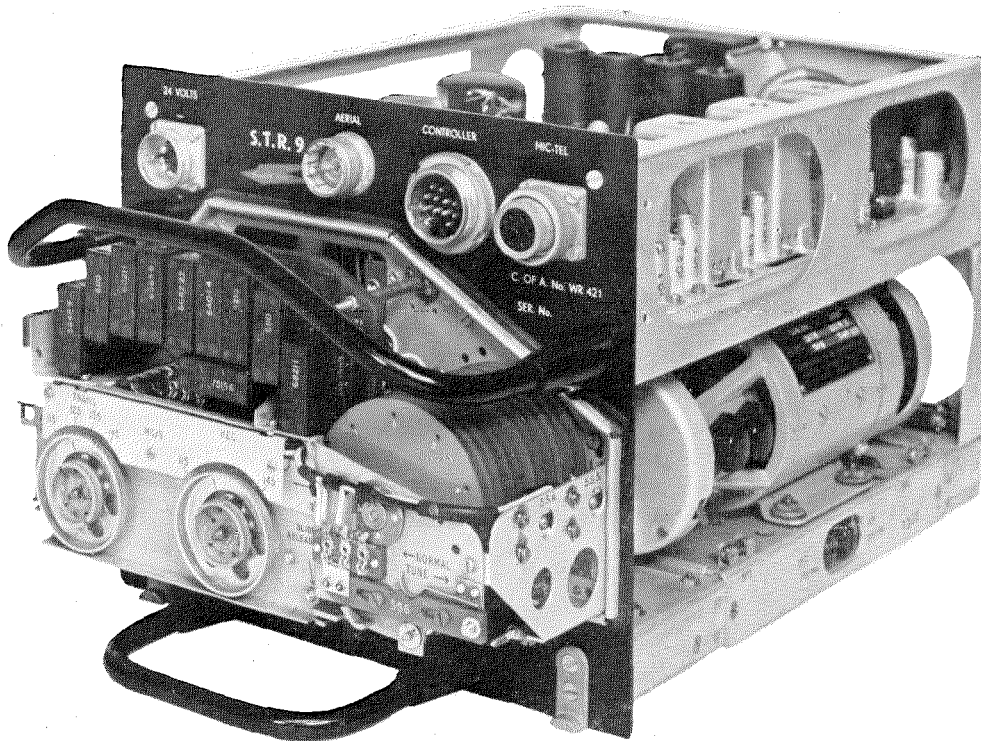

The 10 crystals and channel-selecting mechanism, mounted on the front of the panel, are protected by the handle and guard rail during servicing.

A guard rail has been fitted above the mechanism and in conjunction with the carrying handle permits the set to be stood on its face during servicing.

The redesigned mechanism extends about 1.5 inches farther beyond the front panel than did the 4-channel design and the set now weighs approximately 25 pounds (11.3 kilograms).

The new control unit is 3.7 by 2.2 by 2.75 inches (9.4 by 6 by 7 centimetres) and weighs

9.5 ounces (0.27 kilograms). The internal dial is viewed through a plastic window.

The original design by Standard Telephones and Cables, Limited, was adapted to 10-channel working through the close collaboration of the London, Antwerp, and Stockholm branches of the Standard organisation. Thanks are due to the British Ministry of Supply for permission to record the new frequency range 124.5 to 156 megacycles.

# Characteristics and Adjustment of 335-Megacycle Equisignal Glide Slopes

By SIDNEY PICKLES

*Federal Telecommunication Laboratories, Incorporated, Nutley, New Jersey*

**A**LTHOUGH glide-slope equipments have been in operation for a number of years, adjustment methods and procedures have not been adequately covered in the published descriptions of the apparatus. Increased use of these aids to the landing of aircraft and the desirability of standardizing the signals received in the airplane have stimulated the preparation of this paper.

Several factors influence the radiated signals and include in addition to reflecting surfaces at the site such things as percentage modulation, cross modulation, cross feed, and amplitude and phase relations between the two radiations that comprise the glide slope. Improved performance and increased safety of operation will result from recognition of the order in which the various factors should be examined and the use of suitable test equipment and methods.

. . .

## **1. Theory of Equisignal Glide Slope**

The equisignal glide slope is produced by radiations from two antennas. An upper antenna is placed directly above a lower antenna at several times its height. Figure 1 shows the vertical radiation patterns from the two horizontally polarized antennas. The radio-frequency power supplied to each antenna has a distinctive modulation, being 150 and 90 cycles, respectively, for the upper and lower antennas. (For convenience, it may be remembered that the lower antenna has the lower-frequency modulation and the lower number of radiation lobes.) The first main lobe from the lower antenna encompasses several lobes from the upper antenna, and the intended glide slope is formed where the first lobe from the upper antenna intersects the lower side of the first lobe of the lower antenna.

These patterns are plotted in rectangular coordinates in Figure 2 for convenience in analyzing them. When this equipment was first under de-

velopment, the specifications required that the lobes from the upper antenna encompassed by the first lobe from the lower antenna be at least 4 decibels less in amplitude than the corresponding portions of the lower-antenna lobe. This was with reference to the second, third, and fourth lobes of the upper antenna, which form the first, second, and third low-clearance regions above the glide slope. It was further specified that the point where the fifth lobe from the upper antenna intercepted the upper side of the first lobe of the lower antenna should be at a vertical angle of not less than 6 times the glide-slope angle. Section 5 gives the adjustment procedure to obtain these results.

An investigation of the radiations shown in Figure 2 indicates that alternate lobes of radiation from the upper antenna are of opposite phase. From general considerations, it would seem necessary that the phase of the carrier radiated from the upper antenna should be adjusted so that its first lobe is in phase with the carrier of the first lobe from the lower antenna. Under these circumstances, even-numbered lobes from the upper antenna would have a carrier phase opposite to that of the carrier phase in the first lobe from the lower antenna and odd-numbered lobes would be in phase with the first lobe of the lower antenna.

## **2. Action of Glide-Slope Signals on Linear Detectors**

An investigation of detector action under the condition of a lack of carrier shows that what is known as "swamping effect" takes place; i.e., if one signal is somewhat predominant in magnitude over the other, detection of the signals will result in a considerably greater ratio between the audio-frequency outputs than would be the case if the carriers had been in phase and of sufficient amplitude. Of course, the magnitude of the desired audio-frequency signals would be somewhat

less because of the production of cross modulation and harmonics. However, the important point is the increased ratio that is developed between the desired modulations.

A further investigation of the swamping action shows that this effect is most pronounced when the carriers are nearly 135 to 140 degrees, rather than 180 degrees, out of phase. Recordings taken on the glide-slope equipment have shown that this effect markedly improves the first and third low-clearance regions above the glide slope. The question arises as to whether the phase of the carriers at these low-clearance regions should be  $\pm 135$  degrees which, of course, would make the phase of the carriers in the first lobes of the upper and lower antennas  $\mp 45$  degrees.

In a previous article,<sup>1</sup> it was shown that the phase of the carriers from the upper and lower antennas of the glide slope shifted as the equipment was approached from a great distance. The shift consisted of a retardation in phase of the carrier radiated by the lower antenna. The magnitude of this phase shift is a function of the separation of the antennas and the distance from the equipment. At distances less than 100 times the separation of the antennas, the phase of the upper antenna retards considerably and increases in retardation very rapidly as the equipment is approached.

It would be most undesirable for aircraft using the signals near the landing area to find carriers of "on-slope" signals far out of phase. For this reason, it is preferable that the phase of the upper-antenna signal, when far from the equip-

<sup>1</sup> Sidney Pickles, "Army Air Forces' Portable Instrument Landing System," *Electrical Communication*, v. 22, n. 4, pp. 262-294; 1945.

Figure 1—Polar plot of glide-slope radiations.

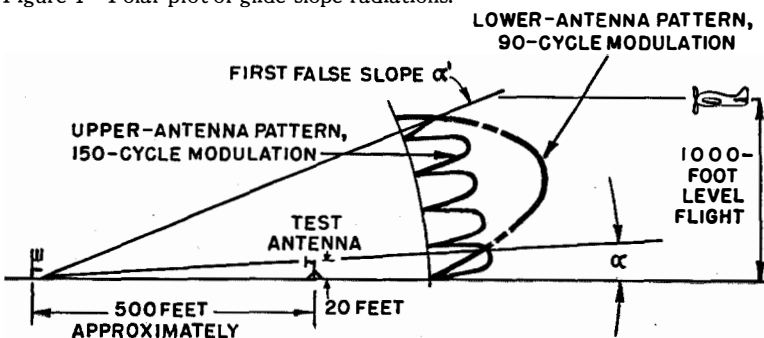

ment, be advanced by approximately 45 degrees with respect to the phase of the carrier from the lower antenna. This advance would allow the carriers to come nearly into phase in the landing region and would provide the increased clearance mentioned previously for the first and third low-clearance regions above the slope when considerably distant from the transmitting antennas.

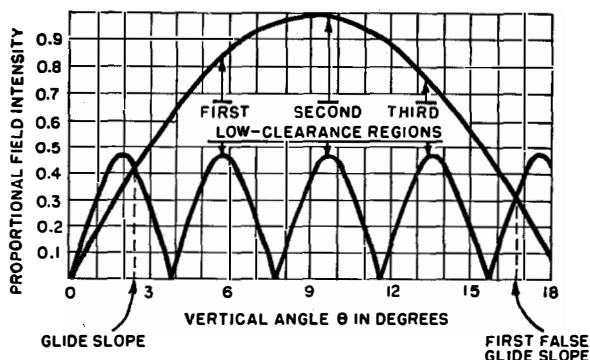

Figure 2—Rectangular plot of glide-slope radiations. The major single lobe is for the lower radiator [ $\sin(565.3^\circ \sin \alpha)$ ] and the several minor lobes are for the upper radiator [ $0.462 \sin(2685^\circ \sin \alpha)$ ].

It was shown several years ago that the phase shift between the two carriers could be nullified or completely eliminated by displacing the upper antenna toward the runway with respect to the lower antenna. However, this would reduce the clearances above the slope and because a phase advance of less than 90 degrees between carriers results in no undesirable effects, it has been found preferable to make the phase shift between carriers a function of distance from the equipment.

### 3. Oscillograms of Glide-Slope Intermediate-Frequency Signals

The test receiving antenna described in Section 5.1 was used to observe the effect of phase on the radio-frequency envelope. The test antenna was set up 1200 feet from the transmitting antennas at the height of an "on-slope" signal. The mast of the glide-slope antennas was set in positions for 0-degree and then for 180-degree carrier phase relations by

the method described in Section 5.3. A local oscillator was used to heterodyne the glide-slope signal down to a frequency that would pass through the amplifier of an oscilloscope. The oscillograms of Figures 3 and 4 each show a cycle of the modulation envelope. Beside each envelope is plotted the calculated detected envelope for one modulation cycle of such signals as taken from equations given in Appendix IV of the article<sup>1</sup> cited. The slight difference in waveforms is due to the fact that an analysis of the oscillograms shows that not exactly equal amounts of 90- and 150-cycle modulations were present. Also a few percent of harmonics and cross-modulation components were present. Otherwise the similarity is striking.

The beat-frequency signal can be used for determining percentage modulation provided the signal level is high enough to make the detectors operate in a linear manner. The beat-frequency method for measuring percent modulation described in Section 5.2 makes use of a stronger signal than can be obtained by the above method.

#### 4. Flight Recordings

In Figure 1, there is shown an aircraft making a level flight over a glide-slope equipment. Such flights provide means for checking the glide-slope angle and also for determining the clearances below and above the slope. Figure 5 shows recordings taken in an aircraft making such flights. When flying above an easily recognizable point on the ground, a mark was made at the beginning of the recording. When flying directly over the glide-slope equipment, another mark was made

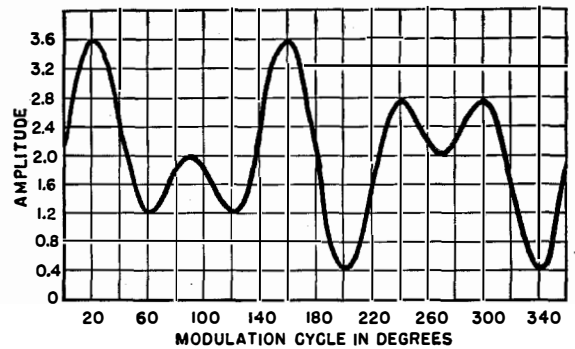
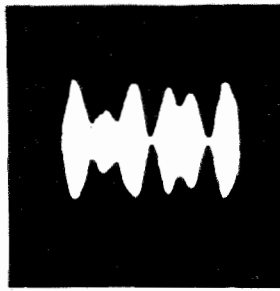

Figure 3—Oscillogram of the beat-frequency envelope of an on-slope signal picked up 1200 feet from the radiators with carriers in phase. The graph at right is the calculated detected envelope of these two amplitude-modulated waves.

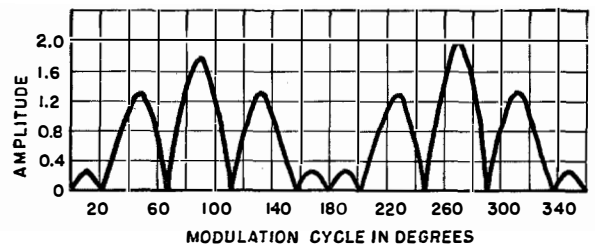
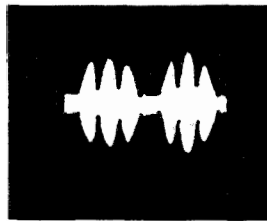

Figure 4—Oscillogram of the beat-frequency envelope of an on-slope signal picked up 1200 feet from the radiators with carriers in phase opposition. The calculated detected envelope for these two amplitude-modulated waves is given at the right.

on the recording. By means of an accurate map, the distance between the two points was determined. Thereby, the distance from the glide-slope equipment to the point in space where the on-slope signal was received could be determined.

The altitude of the flight divided by the distance from the glide-slope equipment to the on-slope signal determines the tangent of the glide-slope angle. The angle is marked on the first recording of Figure 5; in this case, 2.3 degrees. The glide-slope antennas had been set and adjusted to produce a 2.25-degree glide slope.

It is to be noted that the upper antenna was adjusted for a 30-degree phase advance with respect to the lower antenna in this particular instance. It is also to be noted that the first, second, and third low-clearance regions above the slope were essentially equal. This is in contradiction to the actual amplitudes of the signals as shown in Figure 2 and, therefore, must depend on the swamping effect previously mentioned. It is further to be noted that the low-clearance regions have a minimum clearance at least as

great as the maximum "up" signal that was obtained below the slope.

The frequency of the glide-slope equipment was then changed and readjustments made. After the readjustment, a similar level flight was made over the equipment when the upper antenna was again adjusted for a 30-degree phase advance for its carrier relative to the carrier in the lower antenna. By this same means, the point where the on-slope signal was intercepted was determined to be 2.3 degrees once again as shown by the second recording of Figure 5. Another flight was made over the same equipment under the same adjustments except that the upper antenna

was further displaced forward from the lower antenna so as to provide a 70-degree phase advance. A determination of the glide-slope angle intercepted in this case was found to be 2.4 degrees as may be seen in the third recording of Figure 5. This was even further from the adjustment made by use of the test antenna, thereby casting doubt on the validity of such a procedure as described in Section 5. A certain uniformity to the discrepancy is noted. As the phase of the upper-antenna signal with respect to the lower-antenna signal was advanced, the slope appeared to rise. This brought about additional consideration of the problem.

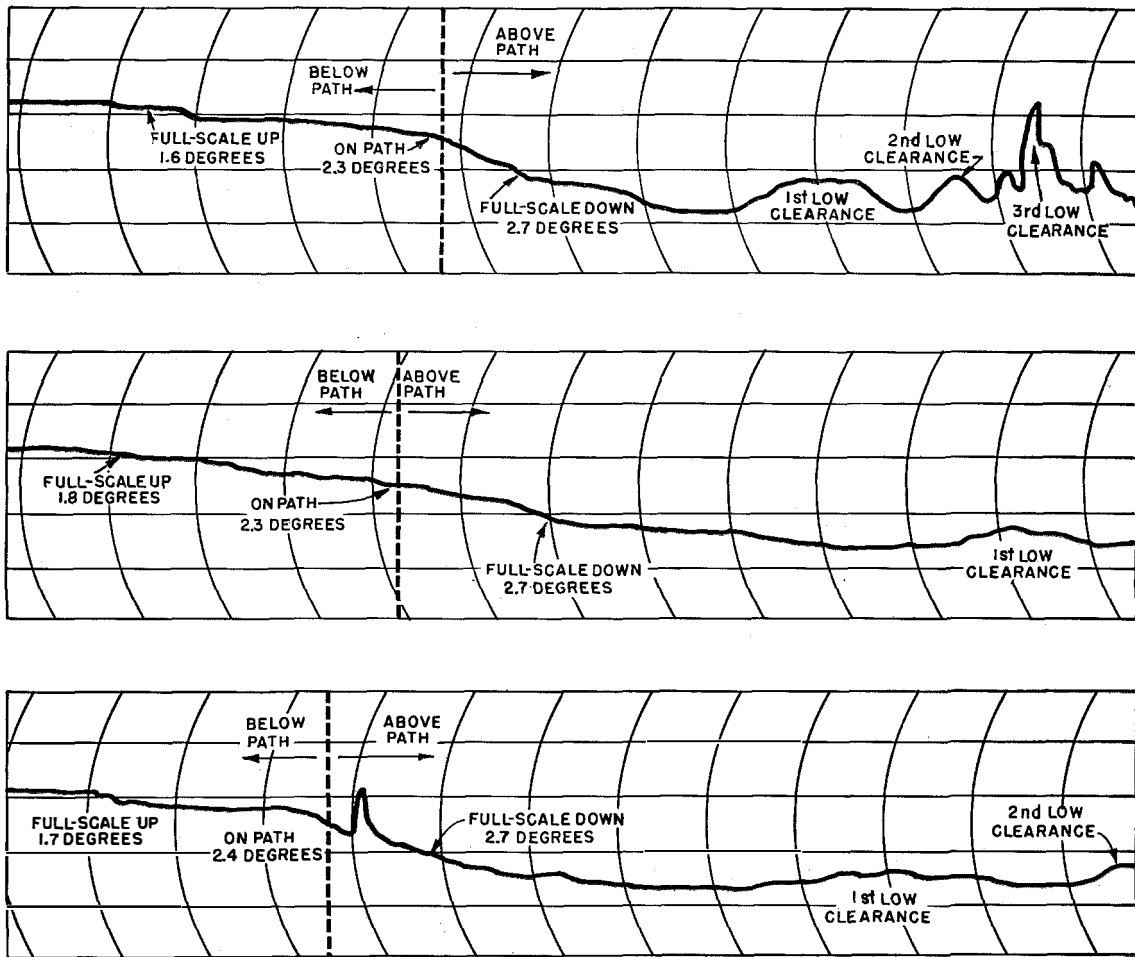

Figure 5—Three recordings taken in flights 1000 feet above the runway for which the glide-slope radiations are adjusted. In the upper record, the transmission frequency was 335 megacycles and the upper-antenna carrier was advanced 30 degrees from that of the lower antenna. In the second record, the carrier relations were also 30 degrees and the frequency was 229 megacycles. The third record was made at the same frequency but with a 70-degree carrier relation. The dashed vertical lines indicate the on-slope point; the glide angle being 2.3 degrees for the upper two records and 2.4 degrees for the bottom record.



It is evident that the low-clearance regions above the slope for both phase conditions were ample and more than could be expected from a consideration of the amplitude values shown in

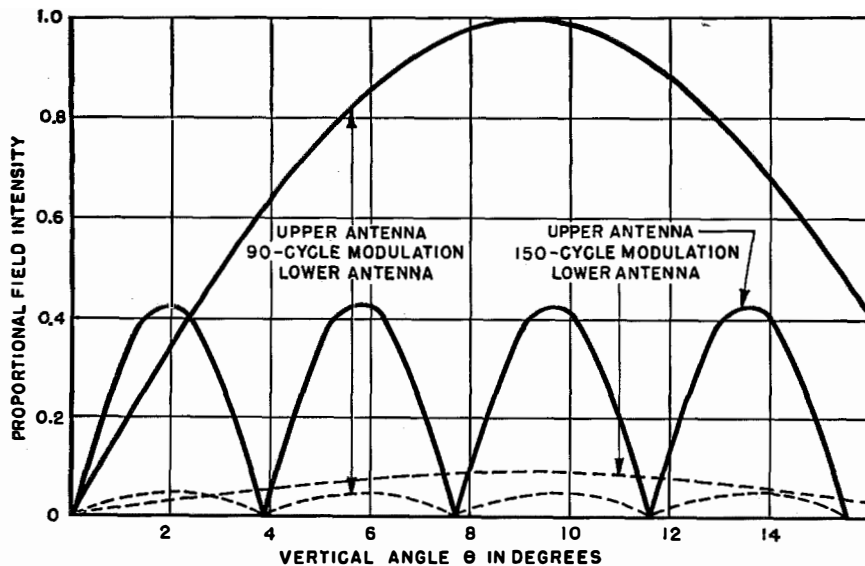

Figure 6—The solid lines show the normal radiation patterns and the dashed lines are the radiations resulting from injecting small amounts of energy from each antenna into the other.

Figure 2. Also, the magnitude of the “up” signals that were found below the slope was also ample.

Figure 6 shows some effects that have long been known but not widely used. Suppose that some of the 90-cycle sideband signal, normally radiated from the lower antenna, is supplied to the upper antenna to be radiated along with its 150-cycle-modulated wave. If the phase of this weaker 90-cycle sideband radiation from the upper antenna is opposite to the phase of the main 90-cycle radiation from the lower antenna, the out-of-phase radiations will cancel. If the radiations are in phase, they will add.

It is also possible for 150-cycle sideband energy from the upper antenna to be injected into the lower antenna. If this signal is radiated in phase with the first lobe of the upper-antenna signal, it will be in phase with succeeding odd-numbered lobes and out of phase with even-numbered lobes. If the phase relations are the reverse of this, the magnitude of the first and third lobes of the upper-antenna signal will be less than required and the second and fourth will be greater.

Figure 7 shows a condition in which approximately 8 percent of each type of modulation was injected into the opposite antenna. The 90-cycle sideband from the lower antenna is out of phase with the first lobe of the upper antenna and the 150-cycle sideband from the upper antenna is in phase with the first lobe of the lower antenna. The clearance below the slope under these circumstances is greater than normal. The slope angle is raised slightly, the first and third low-clearance regions below the slope are greater than normal, and the clearance at the second low-clearance region is decreased. A constant-level flight record similar to Figure 5 taken under these conditions showed clear-

ance below the glide slope to be unusually high. The glide-slope antennas had been set for a 2.5-degree glide slope and the equipment was located on a downhill grade, which should have lowered the glide slope. However, the glide slope was found to be 2.6 degrees. The low-clearance regions above the slope were also found to be unusually good.

In Figure 8, the opposite condition is shown. This is the condition in which the 90-cycle sideband signal from the lower antenna is in phase with the weaker 90-cycle sideband radiation in the first lobe of the upper antenna and the 150-cycle sideband energy in the first lobe of the upper antenna is out of phase with the weaker sideband radiated by the lower antenna. The calculated clearance below the slope is seen to be considerably less than in the previous case. The slope angle is reduced very appreciably and the first clearance above the slope is decreased below normal. Flight recordings confirm these calculations. The phase relations of radiated signals during this recording were 180 degrees from those in the previous recording.

Obviously, cross-feed effects do not have to be present in both antennas at the same time, for cross feed of only one sideband signal can produce nearly the same effects. These results suggest the advisability of testing glide-slope equipments to make optimum use of such cross modulation or cross feed that may exist. If such investigation

is not made, it is possible that the more undesirable condition may prevail, in which case it will be difficult to obtain proper "up" signal below slope and proper clearances above the slope. This fact, of course, is in addition to phase effects on clearances mentioned previously. Ground tests for the cross-feed effect are described in Section 5.4.

In the flight measurement of glide-slope clearances to determine these phase relations between antennas, care has to be given to the selection of the receiver to be used. The type of receiver now in common use has an audio-frequency circuit that varies gain as a function of the level of the received signal. Gain is controlled by distorting the desired modulations into frequencies that do not pass through the filter system. Figure 9 shows two successive recordings using the standard *R89B* receiver with the softening or audio-frequency gain-control circuits and an *R57* receiver, which does not have such characteristics.

The recordings were made on a glide-slope equipment whose carriers from upper and lower antennas were very nearly 180 degrees out of phase. With the *R57* receiver, the first low clearance above the slope was seen to be much less than the second, which indicates the out-of-phase conditions. The recording taken with the *R89B* receiver does not show these effects. Not all *R89B* receivers have the same characteristics and often such receivers do demonstrate the effects shown by the *R57* receiver. This characteristic is a limitation on the use of the *R89B* receivers for phase determination from flight measurements.

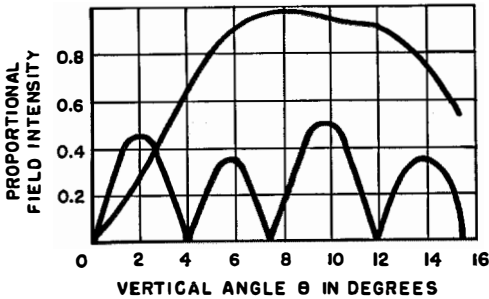

Figure 7—Resultant radiation patterns with cross modulation of approximately 8 percent. With respect to the first radiation lobe of the upper antenna, the 90-cycle sidebands are out of phase between the two antennas and the 150-cycle sidebands are in phase.

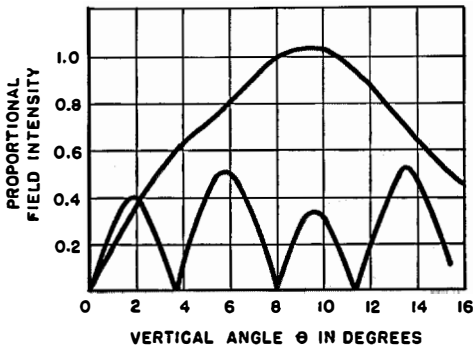

Figure 8—(Above). Resultant radiation patterns with cross modulation of approximately 8 percent. With respect to the first lobe of the upper antenna, the 90-cycle sidebands are in phase and the 150-cycle sidebands are out of phase.

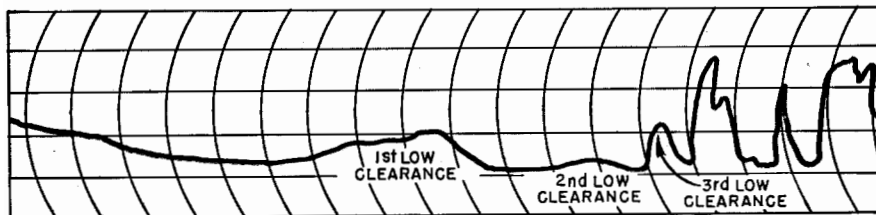
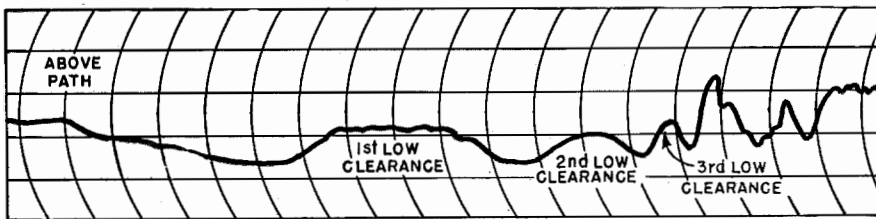

Figure 9—(At right). Two records made at 335 megacycles with carriers from upper and lower antennas very nearly 180 degrees out of phase. The upper record is for the *R89B* receiver and the lower was made with an *R57* receiver.

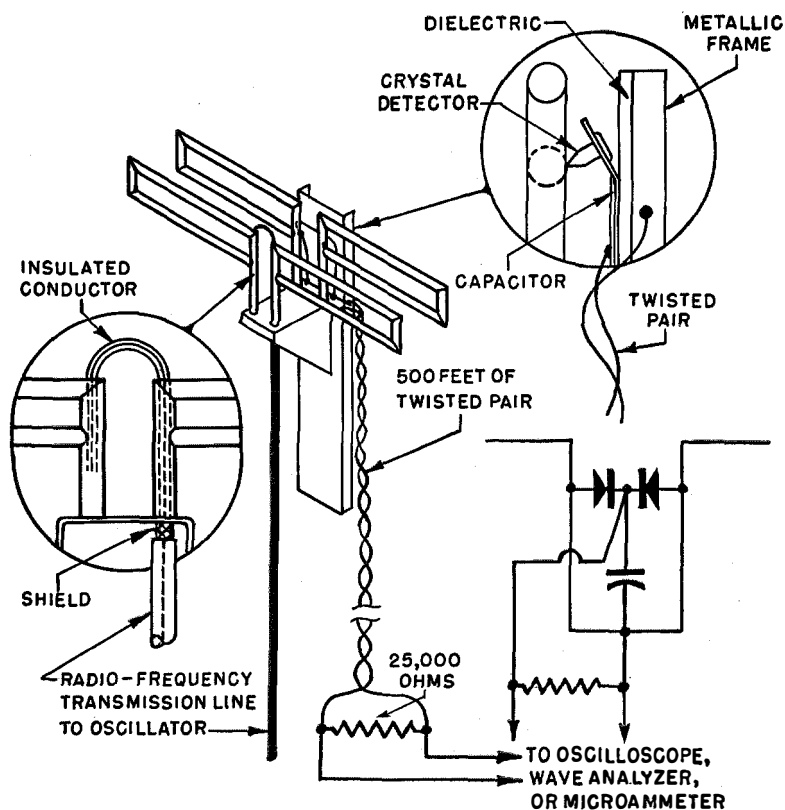

Figure 10—High-gain test antenna with connection for heterodyning oscillator.

usually used for sodded landing areas. If such ground is available and it is evident that it has a grade of less than 0.1 degree with respect to the horizontal, no further investigation of the immediate area need be made except to make sure that the regions to the rear and sides are also clear of large buildings and similar reflecting surfaces for a distance of approximately 500 feet depending on the size of the objects. If the approach region beyond 1000 feet from the equipment meets the requirements for aircraft instrument approach, it will fulfill requirements for the proper radiation of signals from the glide-slope equipment. If such terrain conditions prevail, the test antenna shown in Figure 10 should be set up 20 feet above the ground and at the distance from the equipment specified

The softening circuits have not interfered with the normal operation of the receiver in indicating "on-slope," "fly-up," or "fly-down" signals.

in Table 1. If conditions are otherwise, see Section 6.

### 5. Installation and Adjustment

The following steps should be taken in the installation and adjustment of a 335-megacycle glide-slope equipment.

- A. Site analysis.
  - a. Reflecting-surface determination.
  - b. Necessary freedom from reflecting objects.
  - c. Test-antenna position.
- B. Cross-modulation and percentage-modulation adjustment.
- C. Amplitude and phase adjustments.
- D. Cross-feed phase test.
- E. Flight check.

#### 5.1 SITE ANALYSIS

It is most desirable that glide-slope sites on the approach side be for at least 1000 feet in front of the equipment smooth level ground such as is

#### 5.2 CROSS-MODULATION AND PERCENTAGE-MODULATION ADJUSTMENTS

The test antenna may be used for cross-modulation and percentage-modulation adjustments. In adjusting the percentage of modulation, only one signal should be radiated, the other

TABLE 1

DISTANCE BETWEEN EQUIPMENT AND TEST ANTENNA

$\theta$ Glide-Slope Angle in Degrees	$S$ Distance in Feet from Glide-Slope Antennas to Test Antenna, 20 Feet High	$\phi$ Phase Shift in Degrees Between Carriers for Distance $S$
2.00	575	77
2.25	512	68
2.50	458	61
2.75	416	55
3.00	382	51
3.25	354	47
3.50	326	44
4.00	286	37

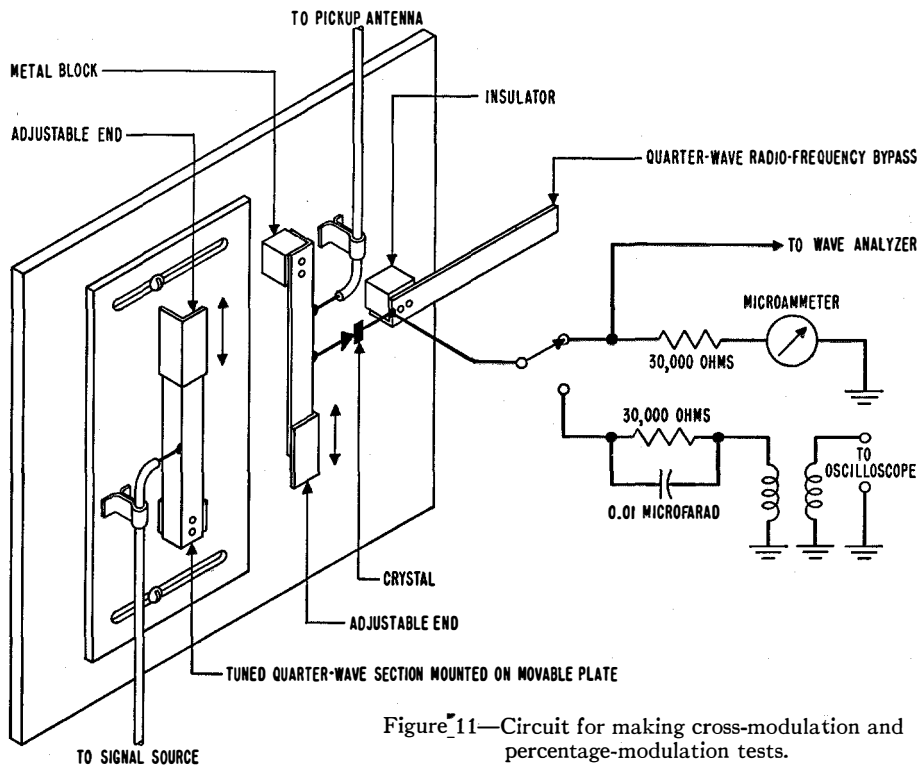

Figure 11—Circuit for making cross-modulation and percentage-modulation tests.

the transformer through which the oscilloscope receives the signal.

During these measurements, both glide-slope antennas can be connected in a normal manner. The pick-up antenna should be close enough to one transmitting antenna so that the signal from the other is relatively weak enough to be of no consequence. To test the relative strengths of the two signals, the desired signal should be dissipated in a non-radiating load while

being dissipated in a nonradiating load. A beating oscillator and oscilloscope with a wide-band amplifier are used in the standard manner for percentage-modulation measurements on the intermediate-frequency envelope.

For convenience and increased accuracy resulting from high signal levels, a simple dipole antenna may be placed immediately adjacent to the glide-slope antennas and signals supplied to the circuit shown in Figure 11. A conventional signal generator is adjusted to beat with the signal from the antenna and produce a frequency that will pass through the oscilloscope amplifier. A Dumont type-208 oscilloscope or its equivalent can be used for measuring the percentage of modulation to within  $\pm 5$  percent of the true value when the maximum deflections on the screen are more than two inches. The percentage modulation is

$$\frac{(\text{maximum deflection}) - (\text{minimum deflection})}{(\text{maximum deflection}) + (\text{minimum deflection})} \times 100.$$

For this measurement, the audio-frequency currents in the detected products are rejected by

the pick-up antenna is kept in place. A measurement of the signal received when the antenna is radiating should also be made. The ratio of desired to undesired pickup should be 50 to 1 or more to insure dependable results.

Before checking percentage modulation, cross modulation and cross-feed signals should be adjusted to a minimum value. Cross-modulation signals are of 60 to 240 cycles. Cross-feed signals are a 90-cycle signal in the 150-cycle antenna and vice versa. These signals should be noted in the wave analyzer with the heterodyning signal turned off. They should be adjusted to a minimum by proper location of the cross-modulation short. Percentage-modulation adjustments should then be made.

By international agreement, modulation is supposed to be adjusted to 95 percent. This is accomplished by means of a short on the modulation section in question. Very small movements of these shorts, equivalent to the thickness of a screw-driver scratch, are required when reaching this high modulation percentage. (Modulation of 75 percent requires a considerably less difficult adjustment of the position of the shorting bar

and is one of many reasons why a lower percentage of modulation is preferable. Greater tolerance of relative carrier phase adjustments is another.)

After these adjustments have been completed for the signals from one antenna, the pick-up antenna should be moved to the immediate vicinity of the other antenna for similar measurements on cross modulation and percentage modulation. It is seldom that the same cross-modulation adjustment will be optimum for signals to both antennas. A compromise adjustment is, therefore, suggested and several tests with the pick-up antenna will be required to bracket the cross-modulation and cross-feed adjustments in the compromise position.

### 5.3 AMPLITUDE AND PHASE ADJUSTMENTS

The signal from the test antenna in the field at the distance specified in Table 1 should be utilized for amplitude and phase adjustments. The signal should be carried back to the vicinity of the glide-slope equipment on a twisted pair. The first adjustment is to determine the relative phase of the carrier signals from the two glide-slope antennas. The microammeter, one preferably having a full-scale deflection for less than 250 microamperes, should be connected in correct polarity to the twisted pair. A plumb line should be suspended from the upper antenna so that the distance  $d_1$  in Figure 12 is more than 18 inches when the mast is vertical.

With signals being transmitted from both antennas, the top of the mast should be tilted toward or away from the test antenna while noting the current in the microammeter. The mast should be tilted to the position where minimum current is obtained, the position of most complete carrier cancellation. The new distance  $d_2$  on the plumb line should be measured. The mast should then be readjusted to  $d_3$ , a more nearly vertical position that will be 18 inches from  $d_2$ . It is preferable to shift the antennas physically for phase adjustments rather than to insert electrical phase shifters in the radio-frequency transmission lines. The small standing-wave ratios produced by the small irregularities in the antennas and phase-shifting devices as a result of manufacturing tolerances will produce ampli-

tude changes as well as phase shifts, and the simultaneous change of both parameters makes the adjustments difficult and confusing.

The twisted pair from the test antenna should then be connected to the wave analyzer. The magnitude of the 90- and 150-cycle signals should be measured and recorded. If they are not equal, the amplitude of the current in the upper antenna should be adjusted until they are equal. If more than a 5-percent change in upper-antenna current has to be made to obtain equality of signals, the phase of the carriers should be reinvestigated by the previous procedure.

### 5.4 CROSS-FEED PHASE TEST

To make use of the remnant cross-feed signals and to ensure that they do not cause decreased up signal below slope and decreased low clearance above slope at the first and third low-clearance regions, the following test should be made. The mast should be tilted forward or backward, whichever way is required to obtain an increase in the ratio of 150- to 90-cycle signals, while all other adjustments and the test-antenna height remain constant. Usually an increased ratio is obtained by tipping the mast forward. It should be continued until the maximum ratio results while changing the plumb-line position preferably not more than 9 inches. At this point, the current in the upper antenna should be readjusted to equalize the 90- and 150-cycle signals.

Providing less than 10 percent of 150-cycle energy is present, this signal will produce an on-slope indication in a receiver that is properly adjusted. However, to project this signal to the point in space where the on-slope signal is to be used, an adjustment for the proximity effect of the test antenna has to be made. Proximity effect<sup>1</sup> is a shift in phase between carriers of two signals radiated from different points as a function of distance from these points. Table 1 shows the amount of this phase shift  $\phi$  for various glide-slope angles. For final adjustment, the upper antenna should be moved backward as indicated by the plumb line. It is helpful to know that 1 inch movement of the plumb line is approximately 10 degrees at the glide-slope transmitting frequency.

5.5 FLIGHT CHECKS

The adjustments previously described test and prepare the equipment for proper operation. Since it is physically quite difficult to support the test antenna at the required altitude when several thousand feet from the equipment, the previous tests do not indicate all effects that the

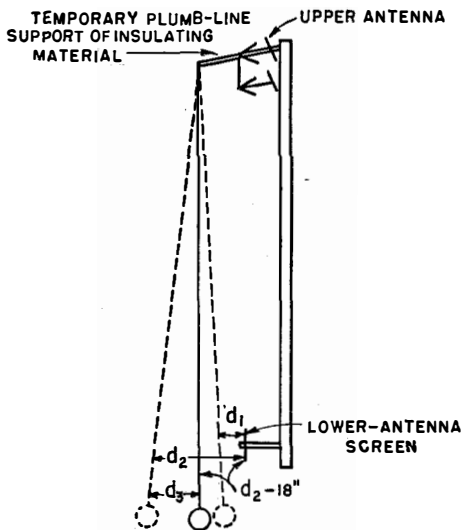

Figure 12—Adjustment of tilt of antenna mast to obtain proper amplitude and phase relations between upper- and lower-antenna radiations.

site may have on the signals. It is, therefore, advisable to make flight checks to determine the effects of the site.

An Esterline-Angus tape recorder, giving a full-scale deflection for 1 milliampere, connected directly to the output of a properly adjusted receiver in place of one cross pointer will serve for recording the flight check. Such a device will not produce full-scale or off-scale indications when so connected. However, much valuable information is lost if an amplifier is used between the receiver and the recorder so that off-scale indications will be obtained in regions of maximum deflection where more than full-scale cross-pointer current is obtained. As described in the earlier article,<sup>1</sup> quantitative phase checks on the carriers can be obtained from these recordings providing the recorder is not driven off scale by an added amplifier between the cross-pointer circuit and the recorder.

A check on the glide-angle adjustment can be obtained by noting on the recording the point where the flight passes over an easily recognizable mark on the terrain several miles (6 to 8) from the equipment. The flight should then continue at constant altitude and speed while recording the glide-slope signals. The point on the recording when passing directly over the glide slope should be marked. From a suitable map of the region, the distance between the two points can be obtained. From this information, the distance from the glide-slope equipment to the point where the on-slope signal was recorded can be determined. The altitude of the level flight divided by the distance between the glide-slope equipment and the on-slope signal is the tangent of the glide angle. If an accurate map of the terrain is not available, the length of the runway can be used for calibrating the recording during flight.

The angles from the on-slope signal to full scale below slope and full scale above slope can be calculated in the same manner. However, it is to be pointed out that the glide-slope width is a system characteristic and varies as a function of the receiver gain and transmitter adjustments. Slope width is proportional to percentage modulation in the transmitting equipment. The radio-frequency patterns of the transmitting antennas also can affect the slope width, but any readjustment of the antenna heights to achieve such change will alter the design characteristics of the equipment. Incorrect phase of carriers as received remotely from the equipment will also affect the slope width by swamping action. However, after following and accomplishing the above adjusting procedure, an incorrect slope width is an indication of incorrect receiver adjustment or some abnormal characteristic of the transmitting site.

A flight down the glide slope should be made and recorded to determine whether the site has any undesirable effects other than what had been noted before. The recording should show no irregularities other than increased deflections from on-slope signals as the equipment is approached. This is due to the fact that for a given displacement from on slope, the deflection is increased as the equipment is approached.

6. Reflecting Surfaces Over Rough Terrain

If the ground in front of the glide-slope equipment is somewhat rough and of varying grades,

it is quite likely that a usable glide-slope signal can be produced, but considerable investigation is necessary to determine the grades of the effective signal-reflecting surfaces. The test antenna can be used to investigate the site.

From Figure 2, it is seen that a null in the upper-antenna signal occurs at 1.5 times the glide-slope angle. This ratio holds for all settings of the glide-slope antennas. Therefore, if the null can

be located, the effective reflecting surface for the signals from the upper antenna is at an angle of 1.5 times the glide angle below this null.

To locate the null with the test antenna, the following procedure should be used. The antenna should be taken a considerable distance in front of the equipment depending on the height at which the glide-slope antennas are set. Table 2 shows the recommended distances where the tests should begin. For instance, if the upper antenna is set for a 2.5-degree position, the test antenna should be set up 1030 feet from the glide-slope equipment. It should be raised to approximately 67 feet above the ground and moved up and down to determine the exact location of minimum signal as indicated by a microammeter. It is preferable that the signal be unmodulated. It is essential that the lower-antenna signal be dissipated in a nonradiating load during this procedure. After locating the point of minimum signal, a suitable marker should be left in the position of the antenna. The antenna should then be moved approximately 100 feet nearer the equipment and the procedure repeated. The line connecting the two positions is then known to be 1.5 times the glide angle corresponding to the antenna settings above the effective reflecting surface.

To determine the grade of the reflecting plane for the lower antenna, the upper antenna should remain energized and the lower-antenna signal should be dissipated in a nonradiating load as before. Table 2 should be consulted for the recommended distance at which to set up the test antenna. The null for the upper-antenna signal should be located in two more positions to determine what the position of the reflecting surface

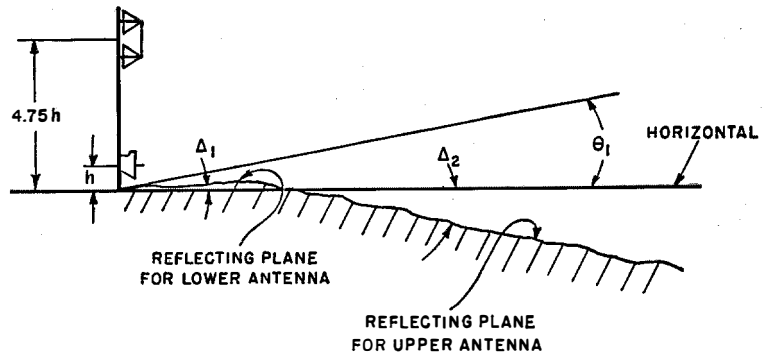

Figure 13—Measurements for detecting the grade of reflecting planes located near the radiators.

may be at this point nearer to the equipment. As before, it will be 1.5 times the glide-angle setting for the upper antenna below the null line.

In Figure 13, let  $\Delta_2$ , measured positive in a clockwise direction, be the angle of the reflecting plane for the upper antenna with respect to the horizontal. The upper antenna should be relocated to a new height

$$H' = \frac{\theta}{\theta + \Delta_2} H,$$

where  $H$  is the upper-antenna height normally required for the selected glide angle  $\theta$ . If  $\Delta_1$  is the corresponding angle of the reflecting plane for the lower-antenna signals, the new height of the lower antenna should be

$$h' = \frac{\theta}{\theta + \Delta_1} h,$$

where  $h$  is the lower-antenna height normally required to produce the desired glide angle  $\theta$ . It must be remembered that if the incremental

TABLE 2  
RECOMMENDED DISTANCE BETWEEN EQUIPMENT AND TEST ANTENNA

$\theta$ Glide-Slope Angle in Degrees	Maximum Distance in Feet From Lower Glide-Slope Antenna	Maximum Distance in Feet From Upper Glide-Slope Antenna	Approximate Height in Feet of Test Antenna at Null of Upper Glide-Slope Antenna
2.00	340	1620	85
2.25	264	1250	75
2.50	216	1030	67
2.75	178	845	61
3.00	150	710	56
3.25	128	610	52
3.50	110	522	48
4.00	84	400	42

angles are counter-clockwise from the horizontal, their signs will be negative.

The test antenna should be set up at the original position and the null relocated. The antenna should then be lowered by an amount corresponding to one-third of the angle at which the upper antenna is set. The twisted pair from the test antenna should then be led back to the glide-slope equipment for the analysis of the signals.

### **7. Measurement of Modulation Percentage**

There are several methods for obtaining a measurement of the percentage modulation of the 335-megacycle signal. In the past, a probe voltmeter has been used to note maximum and minimum signal levels on the radio-frequency lines going to the antennas while manually operating the rotor of the mechanical modulator. Unbalance on the lines and nonlinear characteristics of voltmeters prevents this method from giving results with less than about 20-percent error. Use has also been made of the ratio of direct voltage to audio-frequency alternating voltage in directly detected signals to determine percentage of modulation. However, the method has not been reduced to commercial practice as yet.

The ability of the oscilloscope to delineate the radio-frequency signal has not been made use of in previous methods because of the very high frequency of the glide-slope carrier.

Recent efforts have been directed toward heterodyning the carrier frequency to some lower beat frequency that common oscilloscope amplifiers will pass. The beat signals not only make it possible to measure percentage of modulation on the oscilloscope, but also greatly assist in analyzing all adjustments. In addition, the beat fre-

quency can be put through circuitry somewhat as described above for obtaining a direct reading of percentage of modulation.

The signal generator used in this investigation left something to be desired in the way of frequency stability. Later tests indicated that a crystal-controlled oscillator and multiplier chain were superior as a source of heterodyne signal.

There has also been developed and some use made of another type of percentage-modulation measuring equipment. A square-wave generator instead of a sine-wave generator was used to modulate the signal in the circuit shown in Figure 11. This produced a beat signal in the high audio-frequency range, which could pass through common types of high-quality audio-frequency amplifiers. The output of the audio-frequency amplifier at high level was then detected and the ratio of the different audio-frequency voltages to the direct voltage could be measured with considerable accuracy. The apparatus used for this purpose employed 90- and 150-cycle filters for determining the relative magnitudes of these signals with respect to the direct current from the detector of the audio-frequency equipment. The accuracy of this system has been found to be much better than any previous arrangement and exceeds the accuracy with which the glide-slope modulator can be adjusted.

### **8. Acknowledgment**

Lieutenant Commander B. J. Lauff, U.S.N., Student Officer in electronic engineering at the Post Graduate School at Annapolis, Maryland, provided invaluable assistance in the collecting and correlating of the data obtained in the investigations on which this paper is based.



# Reciprocity Between Generalized Mutual Impedances for Closed or Open Circuits \*

By A. G. CLAVIER

*Federal Telecommunication Laboratories, Incorporated, Nutley, New Jersey*

LET TWO WIRES  $L1$  and  $L2$  be considered and electromotive forces  $E_{P1}$  and  $E_{P2}$  be applied at two small gaps  $P1$  and  $P2$  of the wires, which can either be part of a loop or an open circuit (antennas). The two circuits are assumed to be placed in an isotropic medium. A general expression is obtained between  $E_{P1}$  and  $E_{P2}$  and the corresponding currents  $I_{P1}$  and  $I_{P2}$  at the gaps. In case the electromotive forces are sinusoidal and of the same frequency, the above expression leads to generalized self- and mutual impedances. The mutual impedances are shown to be reciprocal, the demonstration being derived from the reciprocity theorem in the form given to it by Ballantine. The formulas are applied to different cases, such as quasi-stationary current distribution, closely or loosely coupled antennas, and wave projectors. Attention is drawn to the conditions assumed in the demonstration for its validity.

. . .

## 1. Definition of Generalized Mutual Impedances

Let two metallic systems  $D1$  and  $D2$  be considered. It will be assumed that the vector current density  $j$  is related linearly to the total electric field  $e_{total}$  at all points of the systems considered. This is expressed by the following equation

$$j = \gamma e_{total},$$

where  $\gamma$  is the local conductivity.

For the first metallic system  $D1$ , the total electric field may be considered as consisting of three parts:

A. An impressed electric field  $e_{a1}$ , which is due to the action of a source of electric energy acting on  $D1$ .

\* Reprinted from *Proceedings of the I.R.E.*, v. 38, pp. 69-74; January, 1950. Presented at the joint meeting of the American Section of the Union Radio Scientifique International and the Washington Section of the Institute of Radio Engineers in Washington, District of Columbia, May 4, 1948.

B. A self-induced electric field  $e_1$ , due to the action of electric charges set in motion in  $D1$ .

C. An electric field  $e_{21}$ , due to the action of the moving charges on  $D2$ . The same applies to  $D2$  giving the following two equations

$$e_{a1} = \frac{j_1}{\gamma_1} - e_1 - e_{21} \tag{1}$$

$$e_{a2} = \frac{j_2}{\gamma_2} - e_2 - e_{12}. \tag{2}$$

By scalar multiplication of (1) by  $j_1$  and (2) by  $j_2$ , two corresponding energy equations can be written.

$$\int_{D1} e_{a1} j_1 dv = \int_{D1} \frac{j_1^2}{\gamma_1} dv - \int_{D1} e_1 j_1 dv - \int_{D1} e_{21} j_1 dv \tag{3}$$

$$\int_{D2} e_{a2} j_2 dv = \int_{D2} \frac{j_2^2}{\gamma_2} dv - \int_{D2} e_2 j_2 dv - \int_{D2} e_{12} j_2 dv. \tag{4}$$

Let the problem be restricted to the case of two wires with electromotive forces  $\xi_1$  and  $\xi_2$  ap-

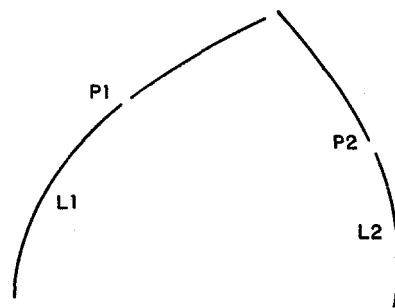

Figure 1.

plied at two infinitesimal gaps  $P1$  and  $P2$  (Figure 1). Then

$$\int_{D1} e_{a1} j_1 dv = \int_{L1} i_1 e_{a1} dl = i_{P1} \mathcal{E}_{P1}$$

$$\int_{D1} \frac{j_1^2}{\gamma_1} dv = \int_{L1} r_1 i_1^2 dl,$$

where  $r_1$  is the linear resistance of wire  $L1$  and  $i_1$  is the current intensity. Similar transformations being applied to the terms of (3) and (4) finally result in

$$\mathcal{E}_{P1} = i_{P1} \left( \int_{L1} r_1 \frac{i_1^2}{i_{P1}^2} dl - \int_{L1} \frac{i_1}{i_{P1}} \frac{e_{12} dl}{i_{P1}} \right) + i_{P2} \left( - \int_{L1} \frac{i_1}{i_{P1}} \frac{e_{21} dl}{i_{P2}} \right) \quad (5)$$

$$\mathcal{E}_{P2} = i_{P1} \left( - \int_{L2} \frac{i_2}{i_{P2}} \frac{e_{12} dl}{i_{P1}} \right) + i_{P2} \left( \int_{L2} r_2 \frac{i_2^2}{i_{P2}^2} dl - \int_{L2} \frac{i_2}{i_{P2}} \frac{e_{21} dl}{i_{P2}} \right) \quad (6)$$

Let the problem be further restricted to the case of functions varying harmonically with time so that

$$i_{P1} = \text{Real } I_{P1} \exp j\omega t$$

$$\mathcal{E}_{P1} = \text{Real } \mathcal{E}_{P1} \exp j\omega t, \text{ etc.}$$

In this case, (5) and (6) become

$$\mathcal{E}_{P1} = I_{P1} \left( - \int_{L1} r_1 \frac{I_1}{I_{P1}} \frac{I_1^*}{I_{P1}^*} dl - \int_{L1} \frac{I_1^*}{I_{P1}^*} \frac{E_{12} dl}{I_{P1}} \right) + I_{P2} \left( - \int_{L1} \frac{I_1^*}{I_{P1}^*} \frac{E_{21} dl}{I_{P2}} \right) \quad (7)$$

$$\mathcal{E}_{P2} = I_{P1} \left( - \int_{L2} \frac{I_2^*}{I_{P2}^*} \frac{E_{12} dl}{I_{P1}} \right) + I_{P2} \left( \int_{L2} r_2 \frac{I_2}{I_{P2}} \frac{I_2^*}{I_{P2}^*} dl - \int_{L2} \frac{I_2^*}{I_{P2}^*} \frac{E_{21} dl}{I_{P2}} \right) \quad (8)$$

Equations (7) and (8) define self- and mutual generalized impedances.

$$\mathcal{E}_{P1} = Z_{11} I_{P1} + Z_{12} I_{P2} \quad (9)$$

$$\mathcal{E}_{P2} = Z_{21} I_{P1} + Z_{22} I_{P2} \quad (10)$$

For any physical circuits, (9) and (10) are consistent, so that

$$Z_{11} Z_{22} - Z_{12} Z_{21} \neq 0.$$

There is reciprocity between mutual impedances when

$$Z_{12} = Z_{21}.$$

The present paper is concerned with the demonstration of this property and the formulation of the conditions for which it is valid.

## 2. Analogy with the Electrostatic Case of Mutual Coefficients of Capacitance

It is of interest at this stage to recall the demonstration of the reciprocal property of electrostatic coefficients of capacitance.

Let a closed electrostatic system be considered (Figure 2) consisting of two metallic bodies  $D1$  and  $D2$  inside a metallic screen  $D0$ .

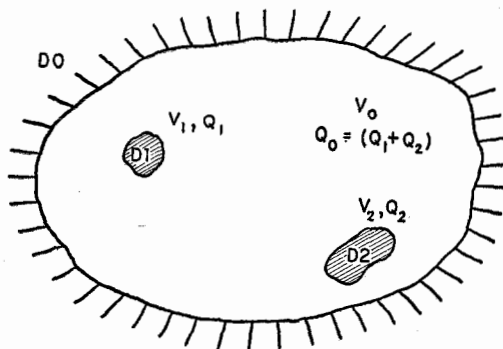

Figure 2.

The coefficients of capacitance are defined in terms of the charges and electrostatic potentials by the following equations:

$$Q_1 = C_{11}(V_1 - V_0) + C_{21}(V_2 - V_0)$$

$$Q_2 = C_{12}(V_1 - V_0) + C_{22}(V_2 - V_0).$$

To demonstrate that  $C_{21} = C_{12}$ , a preliminary lemma is demonstrated (lemma from Gauss) utilizing Green's theorem. Let a closed system be considered with  $n$  metallic bodies inside a metallic screen. Let two possible equilibrium states be denoted by

$$Q_0, Q_1, \dots, Q_n$$

$$V_0, V_1, \dots, V_n$$

and

$$Q'_0, Q'_1, \dots, Q'_n$$

$$V'_0, V'_1, \dots, V'_n.$$

It can be shown that

$$\sum [Q_n(V'_n - V_0') - Q'_n(V_n - V_0)]$$

$$= \int_S (V'E_N - VE_N) ds$$

$$= \int_v \text{div} (V'E - VE') dv = 0,$$

where the  $E$  are the electrostatic field intensities in the two states, and  $E_N$  their components

normal to the metallic surfaces. The notation  $\text{div}$  is for the usual operation of divergence. Symbolically,

$$\text{div} = i \frac{\partial}{\partial x} + j \frac{\partial}{\partial y} + k \frac{\partial}{\partial z}.$$

Applying the lemma for the particular case of two bodies inside the screen and  $V_1 = V_0$ ;  $V_2' = V_0'$  results in the following equation:

$$Q_1(V_1' - V_0') = Q_2'(V_2 - V_0),$$

from which it is immediately deduced that

$$C_{21} = C_{12}.$$

### 3. Electromagnetic Reciprocity Theorem

Just as the demonstration of the reciprocal property of coefficients of capacitance rests with the preliminary demonstration of the lemma from Gauss, so the demonstration of the reciprocity of generalized mutual impedances rests with the demonstration of the "reciprocity theorem."

Let an electromagnetic system be considered, consisting of a certain number of metallic bodies placed in a dielectric medium characterized by constant dielectric and magnetic coefficients  $\epsilon$  and  $\mu$ . Suppose a certain volume  $V$  enclosed in a surface  $\Sigma$  is considered. Consider two possible electromagnetic states, characterized by their distribution of impressed electric intensities ( $E_a, E_a'$ ) and corresponding current densities ( $J, J'$ ) for the particular case of sinusoidal time variations of angular velocity  $\omega$ . The reciprocity theorem is then expressed by the following equation:<sup>1</sup>

$$\int_v (E_a J' - E_a' J) dv = \text{flux}_{\Sigma} \frac{1}{4\pi} (E \times H' - E' \times H),$$

where  $H$  and  $H'$  are the magnetic field intensities in the two states considered and  $E \times H'$  denotes a vector product.

As  $J = \gamma(E_a + E)$ , where  $E$  is the electric field superposed to the impressed field by the action of the moving charges in the system, the left-hand term of the above equation reduces to

$$\int_v \gamma(E_a E' - E_a' E) dv.$$

<sup>1</sup>Stuart Ballantine, "Reciprocity in Electromagnetic, Mechanical, Acoustical, and Interconnected Systems," *Proceedings of the I.R.E.*, v. 17, pp. 929-951; June, 1929.

Furthermore, the various quantities involved are related by Maxwell's equations

$$\text{curl } H = 4\pi J + j\omega\epsilon E$$

so that the volume integral is found to be equal to

$$\frac{1}{4\pi} \int_v \text{div} (E \times H' - E' \times H) dv$$

equivalent, therefore, to

$$\text{flux}_{\Sigma} \frac{1}{4\pi} (E \times H' - E' \times H),$$

which demonstrates the reciprocity theorem in the form given to it by Ballantine.<sup>1</sup>

It can now be observed that extending the volume  $V$  to the whole space, the quantity

$$\text{flux}_{\Sigma} \frac{1}{4\pi} (E \times H' - E' \times H)$$

tends toward<sup>2</sup> 0.

This is so because far from the metallic bodies the fields reduce to radiated fields. At a very great distance, all points on an enclosing surface may be considered as located on a sphere with a fictitious equivalent electromagnetic source at its center. The electric and magnetic radiated fields tend to become perpendicular to the radius and are such as to produce a localized equipartition of electric and magnetic energy [ $E = (\mu/\epsilon)^{1/2} H$ ]. The theorem of reciprocity can thus be written for any physical system.<sup>3</sup>

$$\int_{\infty} (E_a J' - E_a' J) dv = 0.$$

Reducing this to the special case of wire circuits (Figure 1)

$$\int_{L_1} i' E_a dl = \int_{L_2} i E_a' dl$$

or

$$\int_{L_1} id\mathcal{E}_a = \int_{L_2} id\mathcal{E}_a'.$$

Let the theorem be first applied to two closed circuits (Figure 3). The linear dimensions of the circuits are assumed to be sufficiently small with respect to the wavelength, corresponding in the

<sup>2</sup>H. A. Lorentz, "Communication," *Amsterdamer Akademie van Wetenschappen*, v. 4, p. 176; 1895-1896.

<sup>3</sup>J. R. Carson, "Reciprocal Theorems in Radio Communication," *Bell System Technical Journal*, v. 3, pp. 393-399; July, 1924. Also *Proceedings of the I.R.E.*, v. 17, pp. 952-956; June, 1929.

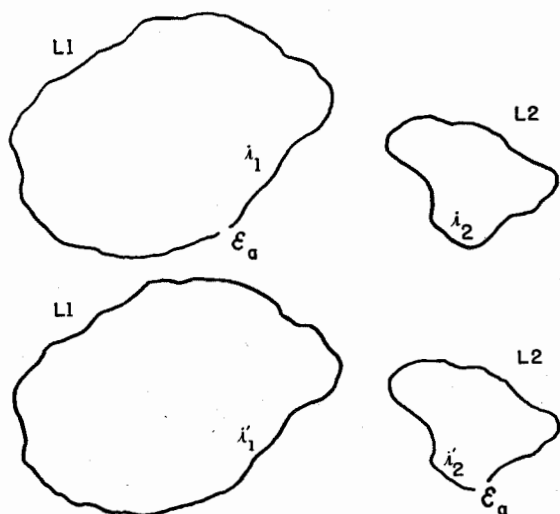

Figure 3.

dielectric medium ( $\epsilon, \mu$ ) to the angular velocity  $\omega$ , so that the current intensities may be considered as constant along the wires.

In a first state, an electromotive force  $\epsilon_a$  is applied to  $L1$  and the currents observed in  $L1$  and  $L2$  are  $i_1$  and  $i_2$ , respectively. In a second state, the same electromotive force is applied to  $L2$  and the currents are  $i'_1$  and  $i'_2$ . The reciprocity theorem gives

$$\begin{aligned} \epsilon_a i'_1 &= \epsilon_a i_2 \\ i'_1 &= i_2. \end{aligned}$$

This is the form given by Lord Rayleigh to the reciprocity theorem. It can be generalized to transient phenomena as the effect of any electromotive force suddenly applied to one of the circuits will be equivalent to the summation of the differential components of a Fourier integral, and the theorem will apply for each differential component individually. It can also be easily extended to all forms of passive electrical networks. An essential condition for the validity of the theorem in practical cases is, however, that should the electromotive force be produced by a generator and the current measured by an ammeter, both generator and ammeter should be such as to present a negligible internal impedance with respect to the impedances of the external circuits.<sup>4</sup> Thus the positions of an “impedance-

less” generator and an “impedanceless” ammeter in a passive circuit may be interchanged without affecting the current through the ammeter, either in magnitude or in phase, relative to the generator voltage.<sup>5</sup>

The passive networks need not be of the closed type provided the positions of the electromotive force and measured current are accurately specified (Figure 4).

If two open-wire circuits are considered, and the two states shown in Figure 4 realized, then  $i_{P1}' = i_{P2}$ .

The reciprocal property of generalized mutual impedances is just another way of expressing the same thing. In the first state,

$$\begin{aligned} \epsilon_a &= Z_{11}I_{P1} + Z_{21}I_{P2} \\ 0 &= Z_{12}I_{P1} + Z_{22}I_{P2}. \end{aligned}$$

In the second state,

$$\begin{aligned} 0 &= Z_{11}I_{P2} + Z_{21}I_{P2}' \\ \epsilon_a &= Z_{12}I_{P2} + Z_{22}I_{P2}'. \end{aligned}$$

To be consistent, the following condition must obtain:

$$\begin{bmatrix} Z_{11} & Z_{21} & 0 & \epsilon_a \\ Z_{12} & Z_{22} & 0 & 0 \\ 0 & Z_{11} & Z_{21} & 0 \\ 0 & Z_{12} & Z_{22} & \epsilon_a \end{bmatrix} = 0,$$

<sup>5</sup> IRE Standards on Antennas—Methods of Testing, 1948.

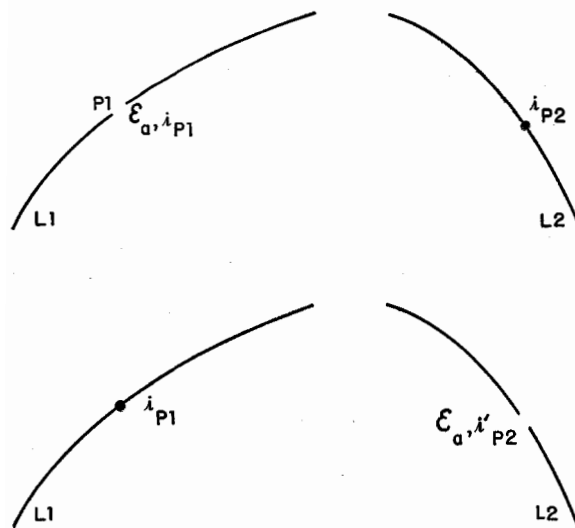

Figure 4.

<sup>4</sup> W. Dällenbach, “Reciprocity Theorem of the Electromagnetic Field,” *Archiv für Elektrotechnik*, v. 36, pp. 153-165; March 31, 1942.

that is to say,

$$(Z_{21} - Z_{12})(Z_{11}Z_{22} - Z_{12}Z_{21}) = 0.$$

As we have seen above that  $Z_{11}Z_{22} - Z_{12}Z_{21} \neq 0$ , it is thus demonstrated that  $Z_{11} - Z_{12} = 0$ .

The extension to  $n$  coupled circuits instead of 2 would result from a similar mathematical procedure.

#### 4. Application to Coupled Circuits

##### 4.1 ELECTRIC QUADRUPOLE

Let electromotive forces  $\mathcal{E}_{P1}$  and  $\mathcal{E}_{P2}$  be applied on the two circuits simultaneously. The following equations are obtained

$$\mathcal{E}_{P1} = Z_{11}I_{P1} + Z_{21}I_{P2}$$

$$\mathcal{E}_{P2} = Z_{12}I_{P1} + Z_{22}I_{P2}.$$

Alternately  $\mathcal{E}_{P2}$  and  $I_{P2}$  can be expressed in terms of  $\mathcal{E}_{P1}$  and  $I_{P1}$ .

$$\mathcal{E}_{P2} = b_{11}\mathcal{E}_{P1} + b_{12}I_{P1}$$

$$I_{P2} = b_{21}\mathcal{E}_{P1} + b_{22}I_{P1}.$$

The reciprocal property of the mutual impedances  $Z_{12} = Z_{21}$  results in a necessary condition for the  $b$  coefficients. For any physical quadrupole, the matrix

$$\begin{vmatrix} b_{11} & b_{12} \\ b_{21} & b_{22} \end{vmatrix}$$

of the coefficients of the above equations must be such as to have its determinant:

$$\begin{vmatrix} b_{11} & b_{12} \\ b_{21} & b_{22} \end{vmatrix}$$

equal to  $-1$ .

##### 4.2 COMPUTATION OF MUTUAL IMPEDANCES

The expression of the generalized mutual impedances has been found above. It is

$$Z_{21} = Z_{12} = - \int_{L1} \frac{I_1^* E_{21} dl}{I_{P1}^* I_{P2}} = - \int_{L2} \frac{I_2^* E_{12} dl}{I_{P2}^* I_{P1}}.$$

Let us consider the case of nondistributed currents in two closed circuits. Then

$$Z_{21} = Z_{12} = - \int_{L1} \frac{E_{21} dl}{I_2} = - \int_{L1} \frac{E_{12} dl}{I_1}.$$

$E_{21}$  can be expressed in terms of a scalar poten-

tial  $\phi_2$  and a vector potential  $A_2$ .

$$E_{21} = -\text{grad } \phi_2 - \mu \frac{\partial A_2}{\partial t}.$$

The circulation of the gradient of  $\phi_2$  along the closed path  $L1$  does not make any contribution to the results. On the other hand, the expression of  $A_2$  is as follows

$$A_2 = \int_{L2} \frac{I_2 \exp\left(-j\frac{\omega}{c}r\right)}{r} dl_2,$$

where  $r$  is the distance from the element  $dl_2$  to the element  $dl_1$  considered, and  $c$  is the speed of light in the medium ( $\epsilon, \mu$ ).

It follows that

$$Z_{21} = j\omega\mu \int_{L1} \int_{L2} \frac{\exp\left(-j\frac{\omega}{c}r\right)}{r} dl_1 dl_2.$$

This expression obviously verifies the reciprocal property of mutual impedances. In case

$$\frac{\omega}{c}r = \frac{r}{\lambda/2\pi}$$

is very small everywhere compared to unity, the above expression is closely approximated by

$$Z_{21} = Z_{12} = j\omega\mu \int_{L1} \int_{L2} \frac{dl_1 dl_2}{r}.$$

The mutual-induction coefficient

$$M = \mu \int_{L1} \int_{L2} \frac{dl_1 dl_2}{r}$$

is thus computable by the well-known Neumann formula. This coefficient becomes complex, however, as soon as the above-mentioned condition does not hold, that is to say, when the radiation field is not negligible.

#### 5. Application to Linear Antennas

##### 5.1 RADIATION COUPLING

In the case when the two linear antennas are located at a distance very great compared with  $\lambda/2\pi$  and their own lengths, the fields  $E_{12}$  and  $E_{21}$  reduce to the radiation fields and can be considered as practically constant along the whole length of each antenna. The expressions

for the mutual impedances are therefore as follows:

$$Z_{12} = -\frac{E_{21}}{I_{P2}} \int_{L1} \frac{I_1^*}{I_{P1}^*} \cos(\mathbf{E}_{21} \cdot d\mathbf{l}) dl$$

$$Z_{21} = -\frac{E_{12}}{I_{P1}} \int_{L2} \frac{I_2^*}{I_{P2}^*} \cos(\mathbf{E}_{12} \cdot d\mathbf{l}) dl$$

In case the antennas are rectilinear, the cosines become constant. Should the antenna lengths be the same and  $P1$  and  $P2$  being corresponding points so that the current distribution becomes identical for both antennas, then the reciprocal property  $Z_{12} = Z_{21}$  results in the following equation:

$$\frac{E_{21}}{E_{12}} = \frac{I_{P1}}{I_{P2}}$$

Finally, for same current amplitudes, the reciprocity between mutual coefficients leads to  $E_{21} = E_{12}$ , that is, to the particular form given to it by Sommerfeld and Pfrang<sup>6</sup> in 1926.

### 5.2 CASES FOR ZERO MUTUAL IMPEDANCES

The expression given above shows the different cases for which mutual impedances can be equal to zero. Consider

$$Z_{12} = Z_{21} = -\frac{E_{21}}{I_{P2}} \int_{L1} \frac{I_1^*}{I_{P1}^*} \cos(\mathbf{E}_{21} \cdot d\mathbf{l}) dl.$$

This expression is zero: (A) when  $E_{21} = 0$ , that is, when antenna 1 is located at a zero field radial with respect to antenna 2; (B) when  $\cos(\mathbf{E}_{21} \cdot d\mathbf{l}) = 0$ , that is, when antenna 1 is at a right angle to the field radiated by antenna 2; and (C) when

$$\int_{L1} \frac{I_1^*}{I_{P1}^*} \cos(\mathbf{E}_{21} \cdot d\mathbf{l}) dl = 0,$$

that is, when the current distribution induced in antenna 1 is such that the work done by the radiated field due to antenna 2 along the length of antenna 1 is zero.

When  $Z_{12} = 0$  for any one of the above causes, then  $Z_{21}$  is necessarily also equal to zero. It may be, however, that the causes that make  $Z_{12}$  and  $Z_{21}$  simultaneously equal to zero result from two different causes among the three listed above.<sup>1</sup>

<sup>6</sup>A. Sommerfeld and H. Pfrang, "The Reciprocity Theorem," *Jahrbuch der drahtlosen Telegraphie und Telephonie*, v. 26, p. 93; 1926. Also, v. 37, pp. 167-169; 1931.

### 5.3 RECIPROCAL PROPERTIES OF SAME ANTENNA USED AS TRANSMITTING AND RECEIVING ELEMENT

Let an antenna be submitted to experimental measurement of its directive properties. In a first series of experiments, let it be used as a transmitting element. The measuring apparatus will include a receiving antenna, and the equations relating the impressed electromotive force and the induced currents will be as before:

$$\mathcal{E} = Z_{11}I_{P1} + Z_{21}I_{P2}$$

$$0 = Z_{12}I_{P1} + Z_{22}I_{P2}$$

However, the reaction of the measuring apparatus on the antenna under test will be made negligible, and the current measured  $I_{P2}$  will be very approximately equal to

$$I_{P2} = -\mathcal{E} \frac{Z_{12}}{Z_{11}Z_{22}}$$

Let the system be reversed and the antenna under test be used as a receiving element. A signal generator will apply an electromotive force  $\mathcal{E}'$  on the same auxiliary antenna as before, and the equations will become

$$0 = Z_{11}I_{P1}' + Z_{21}I_{P2}'$$

$$\mathcal{E}' = Z_{12}I_{P1}' + Z_{22}I_{P2}'$$

In this case, however, the term  $Z_{12}I_{P1}'$  will be negligible in the second equation and the measured current will be given by

$$I_{P2} = -\mathcal{E}' \frac{Z_{21}}{Z_{11}Z_{22}}$$

Thus the radiation diagram and radiation resistance of the same antenna used as a transmitting or receiving element are identical. The previous equations point out that correct experimental results will be obtained, however, in that case only where reaction of the measured on the measuring system can be made negligible.

### 6. Application to Wave Projectors

The reciprocity theorem can also be applied to wave projectors. In this case, however, the most useful form is that due to H. A. Lorentz. Let two systems  $D1$  and  $D2$  be considered with wave projectors  $W1$  and  $W2$  (Figure 5).

Consider the space bounded by surfaces  $\Sigma_1$  and  $\Sigma_2$  on one side and an infinitely remote surface  $\Sigma_0$  on the other side. Consider two possible electromagnetic states denoted by subscripts 1 and 2. The total flux of the vector product  $\mathbf{E}_1 \times \mathbf{H}_2$  is equal to the total flux of the vector product

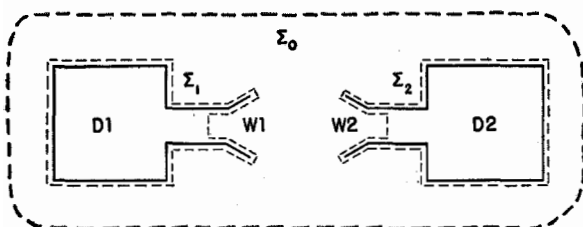

Figure 5.

$\mathbf{E}_2 \times \mathbf{H}_1$ . As explained before, the flux through  $\Sigma_0$ , which can be assimilated to a sphere of infinite radius, is equal in both cases, so that the following equation<sup>7</sup> is obtained

$$\int_{\Sigma_1 + \Sigma_2} (\mathbf{E}_1 \times \mathbf{H}_2)_n d\sigma = \int_{\Sigma_1 + \Sigma_2} (\mathbf{E}_2 \times \mathbf{H}_1)_n d\sigma.$$

In the first state, let  $W1$  be a transmitter and  $W2$  a receiver. The fields in a cross section of the wave guide feeding  $W1$  will be denoted by  $\mathbf{E}_1, \mathbf{H}_1$  and in a cross section of the feeder to  $W2$  by  $\mathbf{e}_2, \mathbf{h}_2$ . In the second case, the fields will be, respectively,  $\mathbf{E}_2, \mathbf{H}_2$  and  $\mathbf{e}_1, \mathbf{h}_1$ . The above equation gives the following relation

$$\int_{\Sigma_1} (\mathbf{e}_2 \times \mathbf{H}_1)_n d\sigma + \int_{\Sigma_2} (\mathbf{E}_2 \times \mathbf{h}_1)_n d\sigma = \int_{\Sigma_1} (\mathbf{E}_1 \times \mathbf{h}_2)_n d\sigma + \int_{\Sigma_2} (\mathbf{e}_2 \times \mathbf{H}_1)_n d\sigma.$$

Now, provided the field distribution across  $\Sigma_1$  in the two cases are the same,

$$\begin{aligned} \int_{\Sigma_1} (\mathbf{E}_1 \times \mathbf{h}_2)_n d\sigma &= - \int_{\Sigma_1} (\mathbf{h}_2 \times \mathbf{E}_1)_n d\sigma \\ &= - \int_{\Sigma_1} (\mathbf{e}_2 \times \mathbf{H}_1)_n d\sigma, \end{aligned}$$

<sup>7</sup> H. Gutton and T. Ortusi, "Sur le Théorème de Réciprocité en Ondes Hertiennes," *Comptes rendus Hebdomadaires des Séances de l'Académie des Sciences* (Paris), v. 217, pp. 677-679; December 27, 1943.

and the same is true for the surface integral on  $\Sigma_2$ . Thus, the previous equation reduces to

$$\int_{\Sigma_1} (\mathbf{e}_2 \times \mathbf{H}_1) d\sigma = \int_{\Sigma_2} (\mathbf{e}_1 \times \mathbf{H}_2) d\sigma,$$

or again to

$$\int_{\Sigma_1} (\mathbf{e}_2 \times \mathbf{E}_1) d\sigma = \int_{\Sigma_2} (\mathbf{e}_1 \times \mathbf{E}_2) d\sigma.$$

This must be true at all times. Consider the case when  $\mathbf{E}_1$  and  $\mathbf{E}_2$  are sinusoidal and in phase:

$$\begin{aligned} E_1 &= |E_1| \cos \omega t \\ E_2 &= |E_2| \cos \omega t. \end{aligned}$$

Let  $\psi_1$  and  $\psi_2$  be the phase shifts of  $\mathbf{e}_1$  and  $\mathbf{e}_2$  with respect to  $\mathbf{E}_2$  and  $\mathbf{E}_1$ . Finally, let  $W1$  and  $W2$  be the transmitted and  $w_1$  and  $w_2$ , the received powers through  $\Sigma_1$  and  $\Sigma_2$ , respectively. The reciprocity theorem gives finally

$$(W_1 w_2)^{\frac{1}{2}} \cos \omega t \cos (\omega t + \psi_2) = (W_2 w_1)^{\frac{1}{2}} \cos \omega t \cos (\omega t + \psi_1).$$

This means that the time taken by the wave to travel from  $D1$  to  $D2$  in the first electromagnetic case is equal to the time taken from  $D2$  to  $D1$  in the second case, whatever may be the obstacles in the path. It also means that the ratio of transmitted to received power is the same in both cases.<sup>7</sup>

### 7. Conditions for Validity of Reciprocity Theorem

It should be emphasized, however, that all the above conclusions depend on the validity of Maxwell's equations at all points of the system considered. That is to say, the characteristic coefficients  $\epsilon, \mu,$  and  $\gamma$  should be independent of time and of electric and magnetic field strengths. More generally, the properties of the medium should be such that the characteristic tensors  $\epsilon_{ik}, \mu_{ik}, \gamma_{ik}$  should be independent of time and field strengths and, furthermore, symmetrical. It is from this latter condition that the reciprocal properties found above are derived.

In practice, such cases as ferromagnetic substances, electronic space charges, and ionized gases are excluded from the foregoing analysis.<sup>2,4</sup>

# Application of Fourier Transforms to Variable-Frequency Circuit Analysis\*

By A. G. CLAVIER

*Federal Telecommunication Laboratories, Incorporated, Nutley, New Jersey*

FOURIER TRANSFORMS are very valuable for the analysis of the behavior of passive circuits when the driving force is frequency modulated. The output current or voltage is expressed in the form of a convolution integral, which can lead either to the expansion given by Carson and Fry or, preferably, to the van der Pol expansion in terms of the values of the transfer admittance or impedance for the instantaneous frequency, and its derivatives.

The proof given here lends itself to a discussion of the conditions for convergency. In certain cases, the convolution integral can be directly expressed in terms of known functions: this is the case, for instance, for broadband frequency-modulation line discriminators, an analysis of which is given.

• • •

## 1. Introduction

Consider a signal given as a function of time  $f(t)$ . With this signal can be associated a Fourier transform

$$T_{\omega} f(t) = \frac{1}{(2\pi)^{1/2}} \int_{-\infty}^{+\infty} f(t) \cdot \exp(-j\omega t) dt. \quad (1)$$

This is a function of  $\omega$  (angular frequency). There exists an extensive class of functions  $f(t)$  [in particular, those for which  $\int_{-\infty}^{+\infty} |f(t)| dt$  exists] for which the inverse transformation defined as

$$T_{\omega}^{-1} T_{\omega} f(t) = \frac{1}{(2\pi)^{1/2}} \int_{-\infty}^{+\infty} T_{\omega} f(t) \cdot \exp(j\omega t) d\omega \quad (2)$$

gives  $f(t)$  as a result.

Extensive lists of Fourier transforms have been

\* Reprinted from *Proceedings of the I.R.E.*, v. 37, pp. 1287-1290; November, 1949. Presented at joint meeting of American Section of Union RadioScientifique International and Washington Section of Institute of Radio Engineers in Washington, District of Columbia, on October 9, 1948.

published;<sup>1</sup> all the main properties will be assumed to be known in the present paper.

A certain number of essentially singular functions can be associated with Fourier transforms. One of the most important is the unit impulse function, defined as follows.

Consider a rectangular pulse as shown in Figure 1. Such a function has a regular Fourier

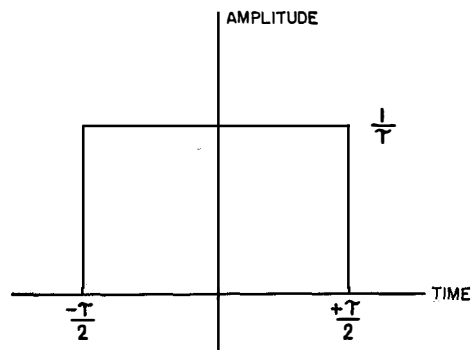

Figure 1.

transform which, according to the adopted definition, is found equal to

$$\frac{1}{(2\pi)^{1/2}} \frac{\sin \omega(\tau/2)}{\omega(\tau/2)}.$$

Let  $\tau$  tend towards 0. The limit is the unit impulse function, the Fourier transform of which is thus  $1/(2\pi)^{1/2}$ . By considering  $1/(2\pi)^{1/2}$  in its turn as the limit of  $\exp -\alpha|\omega|$  when the positive real number  $\alpha$  tends toward 0, it can be shown that  $T_{\omega}^{-1} [1/(2\pi)^{1/2}]$  corresponds to the unit impulse function, which we will designate as  $S_0(t)$ . It can be further shown that  $S_0(t)$  and  $1/(2\pi)^{1/2}$  considered in the previous light constitute a pair of Fourier transforms and can be treated in all mathematical problems as possessing the

<sup>1</sup> See for instance, G. A. Campbell and R. M. Foster, "Fourier Integrals for Practical Applications," *Bell Telephone System Monograph* B.584.



transformation properties associated with this mathematical concept. For instance,  $S_0(t-t_0)$  and  $1/(2\pi)^{1/2} \exp(-j\omega t_0)$  and conversely  $S_0(\omega-\omega_0)$  and  $1/(2\pi)^{1/2} \exp(j\omega_0 t)$  can be manipulated as valid pairs of Fourier transforms. This will be utilized in the following analysis.

**2. General Expression of the Response of a Passive Network<sup>2</sup>**

The value of Fourier transforms resides in the following mechanisms. Starting from a known signal, let the associated Fourier transform be found. This Fourier transform is operated on by the circuit considered, the transfer characteristic of which is assumed to be known for all values of  $\omega$ . The Fourier transform of the response is thus found, from which an inverse transformation  $T_{\omega}^{-1}$  yields the response itself in the signal-time plane of co-ordinates. The general properties of the Fourier transforms will be found to lead quickly to the desired results in a number of cases, for which a more direct analysis is found to be lengthy and cumbersome.

Let a passive circuit be considered and its admittance  $Y(j\omega)$  known for all values of  $\omega$ . Let a signal  $v(t)$  be applied, the response can be written symbolically

$$i(t) = T_{\omega}^{-1}[Y(j\omega)T_{\omega}v(t)]. \tag{3}$$

To solve this equation, let a particular signal be applied to the network instead of  $v(t)$  and, in fact, let it be the unit impulse function  $S_0(t)$ . The corresponding response will be

$$u(t) = T_{\omega}^{-1}\left[Y(j\omega)X\frac{1}{(2\pi)^{1/2}}\right]. \tag{4}$$

This is equivalent to

$$Y(j\omega) = T_{\omega}v(t)u(t). \tag{5}$$

The response  $i(t)$  of the circuit to  $v(t)$  can now be written

$$i(t) = T_{\omega}^{-1}[T_{\omega}v(t)u(t) \cdot T_{\omega}v(t)], \tag{6}$$

that is to say the Fourier transform of the response  $i(t)$  is the product of two Fourier transforms: (A) the Fourier transform of the response of the network to the unit impulse function; (B)

the Fourier transform of the signal  $v(t)$  really applied.

The answer to this problem is given in tables of Fourier transforms. The response  $i(t)$  is given by either one of the following equations

$$\left. \begin{aligned} i(t) &= \int_{-\infty}^{+\infty} u(t-x)v(x)dx \\ i(t) &= \int_{-\infty}^{+\infty} u(x)v(t-x)dx \end{aligned} \right\}. \tag{7}$$

A result that is often expressed by saying that  $i(t)$  is the convolution product of  $u(t)$  and  $v(t)$ .

**3. Example: Elementary Analysis of Line Discriminators**

The direct computation in closed form of the convolution product is possible in certain cases. Let, for instance, a line discriminator be considered (Figure 2).

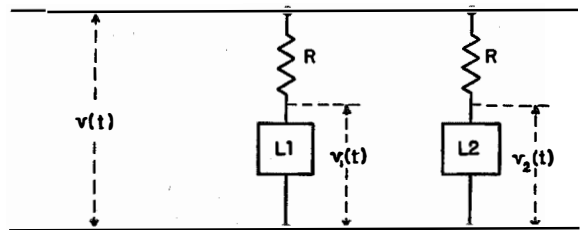

Figure 2.

$L_1$  and  $L_2$  are supposed to be lossless high-frequency lines of characteristic impedance  $Z_0$ . One is open circuited, the other short circuited. Let  $l$  be the electrical length of the lines and  $v$  the phase velocity at angular frequency  $\omega$ . The input impedances of the line are the following

$L_1$  (short circuited)

$$Z_{sc} = Z_0 \frac{1 - \exp(-2j\omega l/v)}{1 + \exp(-2j\omega l/v)} \tag{8}$$

$L_2$  (open circuited)

$$Z_{op} = Z_0 \frac{1 + \exp(-2j\omega l/v)}{1 - \exp(-2j\omega l/v)}. \tag{9}$$

The transfer characteristics from  $v$  to  $v_1$ , and to  $v_2$ , respectively, are as follows,  $R$  being assumed equal to  $Z_0$ ,

$$A_1(j\omega) = \frac{v_1}{v} = \frac{1 - \exp(-2j\omega l/v)}{2} \tag{10}$$

$$A_2(j\omega) = \frac{v_2}{v} = \frac{1 + \exp(-2j\omega l/v)}{2}. \tag{11}$$

<sup>2</sup> A. G. Clavier, "Application de la Transformation de Laplace à l'Étude des Circuits Électriques," *Revue Générale d'Électricité*, v. 51, pp. 447-455; October, 1942.

The responses to unit impulse functions are respectively:

$$u_1(t) = T_{\omega} \frac{A_1(j\omega)}{(2\pi)^{1/2}} = \frac{1}{2} \left[ S_0(t) - S_0\left(t - \frac{2l}{v}\right) \right] \quad (12)$$

$$u_2(t) = T_{\omega} \frac{A_2(j\omega)}{(2\pi)^{1/2}} = \frac{1}{2} \left[ S_0(t) + S_0\left(t - \frac{2l}{v}\right) \right]. \quad (13)$$

Let a frequency-modulated wave be applied, that is to say  $v(t) = \exp j(\omega_0 t + m \sin pt)$ . Then

$$v_1(t) = \int_{-\infty}^{+\infty} u_1(t-x) v(x) dx \quad (14)$$

$$v_2(t) = \int_{-\infty}^{+\infty} u_2(t-x) v(x) dx. \quad (15)$$

The result is, immediately,

$$v_1(t) = \frac{1}{2} \left\{ \exp [j(\omega_0 t + m \sin pt)] - \exp \left\{ j \left[ \omega_0 \left( t - \frac{2l}{v} \right) + m \sin p \left( t - \frac{2l}{v} \right) \right] \right\} \right\}. \quad (16)$$

$$v_2(t) = \frac{1}{2} \left\{ \exp [j(\omega_0 t + m \sin pt)] + \exp \left\{ j \left[ \omega_0 \left( t - \frac{2l}{v} \right) + m \sin p \left( t - \frac{2l}{v} \right) \right] \right\} \right\}. \quad (17)$$

Now, let the electrical length  $l$  be equal to an eighth of the wavelength, that is  $(2\omega_0 l/v) = \pi/2$ . The following equations are obtained

$$v_1(t) = \frac{v(t)}{2} [1 + j \exp(jma)] \quad (18)$$

$$v_2(t) = \frac{v(t)}{2} [1 - j \exp(jma)], \quad (19)$$

where

$$a = \sin p \left( t - \frac{2l}{v} \right) - \sin pt \quad \left. \begin{aligned} & \\ & = 2 \sin \frac{\pi}{4} \frac{p}{\omega_0} \cos p \left( t - \frac{l}{v} \right). \end{aligned} \right\} \quad (20)$$

The amplitudes of  $v_1(t)$  and  $v_2(t)$  are thus equal to the following

$$v_1 = \frac{2^{1/2}}{2} \left( \cos \frac{ma}{2} - \sin \frac{ma}{2} \right) \quad (21)$$

$$v_2 = \frac{2^{1/2}}{2} \left( \cos \frac{ma}{2} + \sin \frac{ma}{2} \right). \quad (22)$$

If  $v_1$  and  $v_2$  are applied to linear detectors and

opposed, the following response is proportional to

$$V_2 - V_1 = 2^{1/2} \sin \left[ m \sin \frac{\pi}{4} \frac{p}{\omega_0} \cos p \left( t - \frac{l}{v} \right) \right]. \quad (23)$$

If square-law detectors are utilized, the response is proportional to

$$V_2^2 - V_1^2 = \sin \left[ 2m \sin \frac{\pi}{4} \frac{p}{\omega_0} \cos p \left( t - \frac{l}{v} \right) \right]. \quad (24)$$

Provided that in the first case  $m \sin (\pi/4)(p/\omega_0) \ll 1$  and in the second case  $2m \sin (\pi/4)(p/\omega_0) \ll 1$ , the output signals are to a close approximation proportional to

$$\frac{\pi 2^{1/2}}{4} \frac{\Delta\omega_0}{\omega_0} \cos p \left( t - \frac{l}{v} \right) \text{ (linear detectors)} \quad (25)$$

$$\frac{\pi}{2} \frac{\Delta\omega_0}{\omega_0} \cos p \left( t - \frac{l}{v} \right) \text{ (square-law detectors)}. \quad (26)$$

It is thus shown, with a minimum of mathematics, that the dynamic response of line discriminators can be made very satisfactorily linear. The residual amount of distortion involved could be determined from the previous expressions.

#### 4. General Case: Expansion of Response as a Function of Instantaneous Frequency

Let us come back to the more general expression of the response

$$i(t) = \int_{-\infty}^{+\infty} u(x) v(t-x) dx, \quad (7)$$

where  $u(t)$  is the response of the network to the unit impulse function applied at time  $t=0$ . This function is 0 for  $t < 0$  so that

$$i(t) = \int_0^{+\infty} u(x) v(t-x) dx.$$

Let a frequency-modulated wave be applied, that is  $v(t) = \exp \{j[\omega_0 t + s(t)]\}$ . The response  $i(t)$  can be written

$$\begin{aligned} i(t) &= \int_0^{+\infty} u(x) \exp [j\omega_0(t-x)] \exp [js(t-x)] dx \\ &= \exp [j(\omega_0 t + s)] \int_0^{+\infty} u(x) \exp [-j(\omega_0 + s')x] \\ &\quad \cdot \exp \{j[s(t-x) - s(t) + xs'(t)]\} dx. \end{aligned} \quad (27)$$

Assume that  $s(t)$  is everywhere expansible in a Taylor series

$$s(t-x) = s(t) - xs'(t) + \frac{x^2}{2}s''(t) \dots, \quad (28)$$

which is certainly true for all signals formed with a finite number of sine waves, then the series

$$\begin{aligned} &\exp \{j[s(t-x) - s(t) + xs'(t)]\} \\ &= 1 + j\frac{x^2}{2}s'' - j\frac{x^3}{6}s''' + \frac{x^4}{24}(js^{IV} - 6s''^2) \dots \quad (29) \end{aligned}$$

will be convergent for all values of  $x$ .

It can be shown that, since  $u(t)$  is the response of a passive network to a unit impulse function, the series obtained by the term-by-term integration of

$$\exp [j(\omega_0 t + s)] \int_0^{+\infty} u(x) \exp [-j(\omega_0 + s')x] \left[ 1 + j\frac{x^2}{2}s'' - j\frac{x^3}{6}s''' + \frac{x^4}{24}(js^{IV} - 6s''^2) + \dots \right] dx \quad (30)$$

will converge toward  $i(t)$ .

In this expression,  $u(t)$  is the response of the network to the unit impulse function, so that

$$\left. \begin{aligned} Y(j\omega) &= (2\pi)^{1/2} T_s u(t) \\ &= \int_0^{+\infty} u(t) \exp (-j\omega t) dt. \end{aligned} \right\} \quad (31)$$

On the other hand,  $\omega_0 + s'(t)$  is the derivative with respect to time of the phase of the voltage  $v(t)$  applied to the circuit and, therefore, its instantaneous frequency  $\Omega$ .

The first term of the above integral is

$$\exp [j(\omega_0 t + s)] \int_0^{+\infty} u(x) \exp (-j\Omega x) dx, \quad (32)$$

that is to say,  $\exp [j(\omega_0 t + s)] Y(j\Omega)$ .

This means that the first approximation of the response of the passive network to the impressed frequency-modulation voltage is obtained by utilizing the stationary admittance for a value of frequency equal to the instantaneous frequency.

Let, for instance, a voltage be frequency modulated in such a way that the instantaneous frequency varies sinusoidally and this voltage be applied to a resonant circuit. Let the current be detected and its amplitude impressed on the vertical plates of an oscilloscope, the horizontal plates being submitted to the action of a voltage proportional to the instantaneous frequency. The curve on the screen will, to the approximation

considered, be identical with the stationary resonance curve of the circuit.

The second term of the expansion is

$$\exp [j(\omega_0 t + s)] \int_0^{+\infty} j\frac{x^2}{2}s'' u(x) \exp (-j\Omega x) dx, \quad (33)$$

that is to say,

$$j\frac{s''}{2} \exp [j(\omega_0 t + s)] \int_0^{+\infty} x^2 u(x) \exp (-j\Omega x) dx.$$

The integral is the expression of

$$T_x^2 x^2 T_\Omega^z Y(j\Omega). \quad (34)$$

Utilizing one of the basic properties of the Fourier transforms, viz.

$$T_x^n x^n T_\Omega^z Y(j\Omega) = (-1)^n \frac{\partial^n Y(j\Omega)}{\partial (j\Omega)^n}, \quad (35)$$

the second term is equal to

$$j\frac{s''}{2} \exp [j(\omega_0 t + s)] \frac{\partial^2 Y(j\Omega)}{\partial (j\Omega)^2}, \quad (36)$$

similarly, the third term is

$$+ j\frac{s'''}{6} \exp [j(\omega_0 t + s)] \frac{\partial^3 Y(j\Omega)}{\partial (j\Omega)^3}, \quad (37)$$

and the fourth

$$\exp [j(\omega_0 t + s)] \frac{js^{IV} - 6s''^2}{24} \frac{\partial^4 Y(j\Omega)}{\partial (j\Omega)^4}, \quad (38)$$

and so on.

This expansion of the response of a passive network to a frequency-modulated wave in terms of the values of the admittance and its derivatives in which the stationary frequency is replaced by the instantaneous frequency was first arrived at by van der Pol,<sup>3</sup> who, however, utilized a different demonstration.

Let us consider again the series-resonant circuit for which it is desired to plot the response of a linear detector versus instantaneous frequency.

The high-frequency output response has just

<sup>3</sup> B. van der Pol, "Fundamental Principles of Frequency Modulation," *Journal of the Institution of Electrical Engineers*, v. 93, Part III, pp. 153-158; May, 1946.

been found to be

$$\exp [j(\omega_0 t + s)] \left[ Y(j\Omega) + \frac{1}{2} j s'' \frac{\partial^2 Y(j\Omega)}{\partial (j\Omega)^2} + \dots \right]. \quad (39)$$

Let us consider in which case the second term in the brackets can be neglected with respect to the first so that the curve shown on the scope will be very close to the resonance curve of the circuit.

Let

$$s = \omega_0 t + \frac{\Delta\omega_0}{p} \sin pt, \quad (40)$$

then

$$s'' = -p \cdot \Delta\omega_0 \sin pt. \quad (41)$$

At maximum frequency deviation,  $s'' = 0$  and the second term is zero. Let us investigate what happens at resonant frequency.

From

$$Y(j\Omega) = \frac{1}{R \left[ 1 + jQ \left( \frac{\Omega}{\omega_0} - \frac{\omega_0}{\Omega} \right) \right]}, \quad (42)$$

where  $Q$  is the usual "Q factor" of the circuit, it is found that

$$\frac{\partial^2 Y}{\partial (j\Omega)^2} = \frac{1}{R} \frac{2Q^2 \left[ \frac{1}{\omega_0^2} + \frac{3}{\Omega^2} \right] - j \frac{2Q\omega_0}{\Omega^3}}{\left[ 1 + jQ \left( \frac{\Omega}{\omega_0} - \frac{\omega_0}{\Omega} \right) \right]^3}. \quad (43)$$

When the impressed frequency-modulated voltage passes through the resonant frequency, the first term of the expansion becomes  $1/R$  and the second

$$-\frac{1}{R} \left[ \frac{Qp \cdot \Delta\omega_0}{\omega_0^2} - j \frac{4Q^2 p \cdot \Delta\omega_0}{\omega_0^2} \right]. \quad (44)$$

The ratio of amplitudes is

$$4Q^2 \frac{p \cdot \Delta\omega_0}{\omega_0^2} \left( 1 + \frac{1}{16Q^2} \right)^{1/2}.$$

For a circuit with a moderate or high  $Q$  factor, the two extreme points reached on the resonance curve and the resonant point itself will practically coincide with the stationary curve provided

$$4Q^2 \frac{p \cdot \Delta\omega_0}{\omega_0^2} \ll 1.$$

As  $Q$  is equal to the ratio of  $\omega_0$  to  $2\pi$  times the 3-decibel bandwidth  $B$  of the circuit, this can also be written, if  $p = 2\pi f$  and  $\Delta\omega_0 = 2\pi F$ ,

$$4 \frac{fF}{B^2} \ll 1.$$

The van der Pol expansion can also be utilized for the computation of the distortion that will be due to a passive network when the output voltage is applied to a limiter-discriminator. According to cases, however, a more or less great number of terms will have to be considered and the phase of the output voltage determined and differentiated with respect to time.

An alternative solution to this problem was given by Carson and Fry<sup>4</sup> in 1937. The expansion they used is not, however, in terms of the values of the transfer characteristics and its derivatives for the instantaneous frequency. The use of one or the other expansion will have to be determined by the amount of mathematical computation involved, once convergence of the expansions has been ascertained for the particular problem considered.

<sup>4</sup>J. R. Carson and T. C. Fry, "Variable Frequency Electric Circuit Theory with Application to the Theory of Frequency Modulation," *Bell System Technical Journal*, v. 16, pp. 513-540; October, 1937.

### *Recent Telecommunication Development*

## **Photographic Copies and Indexes of Electrical Communication**

A NUMBER OF SERVICES have been added recently to those already available to readers and subscribers of *Electrical Communication*.

Libraries and similar organizations often face the problem of storing large numbers of periodicals that are not in daily use but are called for too often to be discarded. Arrangements have been made whereby any subscriber may purchase a positive-image microfilm copy of Volume 26 (1949) for about the cost of binding that volume. Orders should be sent to University Microfilms, 313 North First Street, Ann Arbor, Michigan, and should be accompanied by \$1.50, plus postage, in United States funds. At present, *Electrical Communication* is one of 150 periodicals available from University Microfilms to any subscriber of the desired publication. Prices vary with the periodical.

To centralize the ordering of back issues of communication and electronic publications, Electronics Research Company, Incorporated, 480 Canal Street, New York 13, New York, has been authorized to supply back copies of *Electrical*

*Communication* at the regular price of 50 cents each. If the issue is no longer in print, that organization will supply approximately full-size photostatic copies of individual articles at 20 cents per page. These services are also offered for a number of other journals.

A cumulative index for the first 25 volumes of *Electrical Communication* may be obtained from the publisher, International Telephone and Telegraph Corporation, 67 Broad Street, New York 4, New York for \$1.00 in New York funds. Extra copies of some of the yearly indexes are still available without charge on request. Back copies of the journal, when available, may be obtained for 50 cents each.

The contents of *Electrical Communication* are regularly abstracted or indexed by various services including *Electronic Engineering Master Index*, *Engineering Index*, *Industrial Arts Index*, and *Science Abstracts* as well as in the identical abstract sections appearing in both the *Proceedings of the I.R.E.* and in *Wireless Engineer*.

## Telephone Statistics of the World\*

AS OF JANUARY 1, 1949, there were 65,800,000 telephones in the world, reflecting a gain of 5,200,000 during 1948. Of this increase, 3,580,000 telephones, or 69 percent, were added in North America, and 23.5 percent of the total increase was added in Europe. The balance of the increase, or 7.5 percent, was spread over the four continents of Africa, Asia, Oceania, and South America.

The picture of world telephone distribution as presented in this survey was made possible through the cooperation of government administrations and of private companies that operate the many parts of the global network.

In considering the extent of telephone facilities

by countries, the number of telephones in relation to the population served is a significant measure of comparative development. Six countries had more than 15 telephones per 100 population. They were the United States with 26.1 telephones per 100 of its population, Sweden with 22.1, Canada with 18.8, New Zealand and Switzerland with 17.2 each, and Denmark with 15.3. Argentina, with 4.1 per 100 population, ranked first among the South American countries with respect to telephone density. Sweden led in Europe with 22.1 per 100 population; Israel, in Asia, with 2.4. New Zealand, first in Oceania, had 17.2, and the Union of South Africa led in Africa's countries with 3.2.

### TELEPHONES IN CONTINENTAL AREAS

January 1, 1949†

Continental Area	Total Telephones			Privately Owned		Automatic (Dial)	
	Number	Percent of Total World	Per 100 Population	Number	Percent of Total Telephones	Number	Percent of Total Telephones
North America (less United States)	2,959,000	4.5	4.6	2,613,000	88.3	1,701,000	57.5
United States	38,205,000	58.1	26.1	38,205,000	100.0	23,830,000	62.4
South America	1,574,000	2.4	1.5	810,000	51.5	1,133,000	72.0
Europe	18,940,000	28.8	3.2	2,670,000	14.1	11,960,000	63.1
Asia	1,923,000	2.9	0.2	150,000	7.8	820,000	42.6
Africa	735,000	1.1	0.4	9,000	1.2	475,000	64.6
Oceania	1,464,000	2.2	1.4	106,000	7.2	885,000	60.5
World	65,800,000	100.0	2.8	44,563,000	67.7	40,804,000	62.0

† Partly estimated; data reported as of other dates have been adjusted to January 1, 1949.

\* Abridgement reprinted from a booklet issued by The American Telephone and Telegraph Company.

TELEPHONES IN COUNTRIES OF THE WORLD  
January 1, 1949

Country	Total Telephones			Ownership		Automatic (Dial)	
	Number	Percent of Total World	Per 100 Population	Government	Private	Number	Percent of Total Telephones
<b>NORTH AMERICA</b>							
United States	38,205,483	58.1	26.1	—	38,205,483	23,830,000	62.4
Alaska	12,614	+	13.3	36	12,578	815	6.5
Canada	2,458,000	3.7	18.8	308,700	2,149,300	1,384,000	56.3
Central America	40,900	+	0.4	17,000	23,900	11,400	27.9
Cuba	100,700	0.2	1.9	503	100,197	83,246	82.7
Jamaica	10,275	+	0.8	—	10,275	9,527	92.7
Mexico	248,000	0.4	1.0	835	247,165	169,630	68.4
Puerto Rico	34,763	+	1.6	1,794	32,969	17,467	50.2
Trinidad and Tobago	12,216	+	2.0	—	12,216	7,503	61.4
Other Places	42,100	+	0.6	17,400	24,700	17,850	42.4
<b>SOUTH AMERICA</b>							
Argentina	679,335	1.0	4.1	599,262	80,073	500,872	73.7
Bolivia	7,860	+	0.2	—	7,860	7,415	94.3
Brazil	484,300	0.7	1.0	1,500	482,800	360,000	74.3
Chile	126,033	0.2	2.2	—	126,033	83,693	66.4
Colombia	70,300	0.1	0.6	61,800	8,500	29,950	42.6
Ecuador	18,882	+	0.5	13,927	4,955	4,900	26.0
Paraguay	4,986	+	0.4	4,986	—	4,346	87.2
Peru	44,400	+	0.6	—	44,400	35,085	79.0
Uruguay	77,686	0.1	3.3	76,146	1,540	55,879	71.9
Venezuela	55,272	+	1.2	1,258	54,014	50,755	91.8
Other Places	5,007	+	0.8	5,007	—	171	3.4
<b>EUROPE</b>							
Austria	350,592	0.5	5.0	350,592	—	285,335	81.4
Belgium	601,614	0.9	7.0	601,614	—	443,638	73.7
Bulgaria	(a) 54,347	+	0.8	54,347	—	23,000	42.3
Czechoslovakia	(a) 350,708	0.5	2.9	350,708	—	208,319	59.4
Denmark	644,975	1.0	15.3	(b) 32,196	612,779	259,958	40.3
Finland	302,104	0.5	7.3	34,604	267,500	158,483	52.5
France	2,232,536	3.4	5.5	2,232,536	—	1,336,790	59.9
Germany—American Zone	630,756	1.0	3.8	630,756	—	283,955	45.0
Germany—British Zone	1,160,924	1.8	5.1	1,160,924	—	597,146	51.4
Germany—French Zone	182,356	0.3	3.4	182,356	—	80,000	43.9
Greece	65,078	+	0.8	3,516	61,562	(c) 57,217	87.9
Hungary	(a) 106,768	0.2	1.2	106,768	—	77,492	72.6
Iceland	17,632	+	12.8	17,632	—	10,715	60.8
Ireland	66,806	0.1	2.2	66,806	—	38,325	57.4
Italy	1,014,321	1.5	2.2	—	1,014,321	908,448	89.6
Luxemburg	20,287	+	7.0	20,287	—	14,567	71.8
Netherlands	632,667	1.0	6.4	632,667	—	557,839	88.2
Norway	404,985	0.6	12.7	336,404	68,581	234,760	58.0
Poland	212,000	0.3	0.9	212,000	—	142,000	67.0
Portugal	124,305	0.2	1.5	36,178	88,127	61,259	49.3
Spain	552,467	0.8	2.0	—	552,467	401,800	72.7
Sweden	1,531,473	2.3	22.1	1,529,396	2,077	918,135	60.0
Switzerland	794,832	1.2	17.2	794,832	—	754,056	94.9
United Kingdom	(b) 4,922,816	7.5	9.8	4,922,816	—	3,420,395	69.5
Other Places	1,990,000	3.0	0.7	1,990,000	—	711,500	35.8
<b>ASIA</b>							
China	(a) 244,028	0.4	+	84,028	160,000	178,000	72.9
India	(e) 126,412	0.2	+	124,900	1,512	53,000	41.9
Israel	20,701	+	2.4	20,701	—	18,400	88.9
Japan	(b) 1,348,552	2.0	1.7	1,348,552	—	449,517	33.3
Pakistan	16,454	+	+	16,454	—	9,124	55.5
Turkey	52,423	+	0.3	52,423	—	46,010	87.8
Other Places	147,000	0.2	0.1	92,000	55,000	81,000	55.1
<b>AFRICA</b>							
Algeria	81,800	0.1	0.9	81,800	—	56,665	69.3
Egypt	(a) 98,093	0.1	0.5	98,093	—	65,268	66.5
Morocco	49,034	+	0.5	40,234	8,800	31,250	63.7
Tunisia	22,026	+	0.6	22,026	—	13,005	59.0
Union of South Africa	384,633	0.6	3.2	384,633	—	267,961	69.7
Other Places	97,000	0.1	+	96,745	255	38,100	39.3
<b>OCEANIA</b>							
Australia	995,773	1.5	12.8	995,773	—	602,442	60.5
Hawaii	94,559	0.1	17.5	—	94,559	87,069	92.1
Netherlands Indies	(f) 29,438	+	+	29,438	—	713	2.4
New Zealand	(b) 322,757	0.5	17.2	322,757	—	186,300	57.7
Philippine Republic	11,534	+	+	—	11,534	8,771	76.0
Other Places	20,700	+	+	20,700	—	3,100	15.0

+ Less than 0.1.

(a) January 1, 1948.

(b) March 31, 1949.

(c) Subscribers only.

(d) June 30, 1948.

(e) March 31, 1948.

(f) Territory under authority of

Netherlands Indies Government.

## Contributors to This Issue



ALBERT F. BOFF

ALBERT FRANK BOFF was born in London in 1924. He received the Higher National Certificate in radio engineering in 1944 and the B.Sc. degree in 1946 from London University.

After engaging in research on radio interference for the British Electrical and Allied Industries Research Association, he joined the technical staff of Standard Telecommunication Laboratories where he has been responsible for a number of improved techniques in diverse fields of measurement. He was recently appointed to the research staff of Marconi's Wireless Telegraph Company.

Mr. Boff is a graduate of the Institution of Electrical Engineers.

• • •



PER E. ERIKSON

A. G. CLAVIER. A photograph and biography of Mr. Clavier appears on page 83 of the March, 1950, issue.

• • •

PER E. ERIKSON received his degree in electrical engineering from the Royal Institute of Technology in Stockholm in 1903, and joined the Western Electric Company in New York as a shop student the same year.

Assigned to the engineering department, he was engaged on the early development of loading coils and balanced toll cables. Appointed transmission engineer for Europe in 1909 with headquarters in London, he was in charge of the construction of the London-Birmingham cable, the first loaded long-distance cable installed in Europe.

During 1918, he carried out the reconstruction of the Rio de Janeiro-San Paulo toll line, the first of its kind in Brazil to be equipped with repeaters and loaded toll entrance cables. As assistant European chief engineer of the International Western Electric Company, he had charge of the design of toll transmission systems, which were being introduced into various European countries after the first World War. In 1928, he was made assistant vice president of the International Standard Electric Corporation and European chief engineer in 1930.

Mr. Erikson has been associated with the Comité Consultatif International Téléphonique since 1925. From 1929 to date, he has been a delegate for the International Telephone and Telegraph System operating companies at meetings of that body and since 1934, he has been secretary of the System's committee.

He is a Member of the Institution of Electrical Engineers, London, and a Fellow of the American Institute of Electrical Engineers.

• • •

ROBERT A. HAMPSHIRE was born on December 21, 1912 at Philadelphia, Pennsylvania. He graduated from Polytechnic Institute of Brooklyn in 1934 with a bachelor's degree in electrical engineering.



ROBERT A. HAMPSHIRE

He was employed in 1934 and 1935 by the Ford Instrument Company of Long Island City, New York, and from 1935 to 1938 at the Radio Corporation of America research laboratories at Harrison, New Jersey.

From 1938 to date, Mr. Hampshire has been with Federal Telephone and Radio Corporation, and has been engaged in the development of instrument landing systems since 1941.

Mr. Hampshire is an Associate Member of the Institute of Radio Engineers and of the American Institute of Electrical Engineers, and is a member of Tau Beta Pi.

• • •

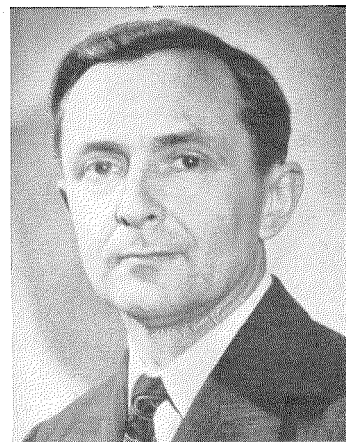

SIDNEY PICKLES





ROBERT W. SANDERS

SIDNEY PICKLES was born in 1909 in Monterey, California. He received the B.A. degree in physics and the electrical engineering degree from Stanford University.

Mr. Pickles came to Federal Telecommunication Laboratories in 1942 after having been with several organizations, including the Civil Aeronautics Authority and Mackay Radio Corporation. He is now one of the department heads in the aerial navigation division.

• • •

ROBERT W. SANDERS was born on May 30, 1916, in Fort Wayne, Indiana. He received the B.S. degree in electrical engineering from Indiana Technical College in 1937.

After two years with the Chicago and Southern Airlines as a communications engineer, he joined Farnsworth Television and Radio Corporation in 1939. Recently, this organization became a member of the International Telephone and Telegraph System as the Capehart-Farnsworth Corporation. Mr. Sanders is now the engineer in charge of the advance development section.

He is a Senior Member of the Institute of Radio Engineers.

• • •

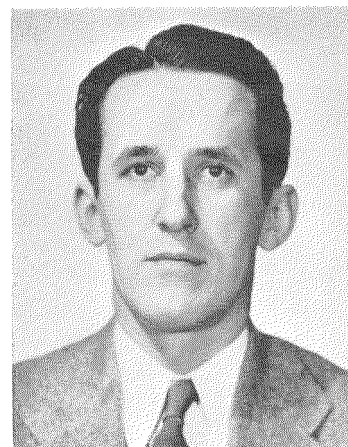

BEN V. THOMPSON

BEN V. THOMPSON was born at Burlington, Iowa, on April 2, 1916. In 1937, he received a B.S. degree in electrical engineering from Texas Technological College and in 1938 his masters degree from Massachusetts Institute of Technology.

Associated with the I.T.&T. System since 1938, he worked on the development of the Civil Aeronautics Administration instrument landing system at Indianapolis, Indiana. In addition to his current engineering work on the

ILS-2 system, he has been concerned with selenium rectifiers, frequency-modulation broadcast transmitters, and with the development of the 200-kilowatt high-frequency broadcast transmitters for the Office of War Information.

Mr. Thompson is an Associate Member of the American Institute of Electrical Engineers and a Senior Member of the Institute of Radio Engineers.

• • •

# INTERNATIONAL TELEPHONE AND TELEGRAPH CORPORATION

## Associate Manufacturing and Sales Companies

### United States of America

International Standard Electric Corporation, New York, New York  
Federal Telephone and Radio Corporation, Clifton, New Jersey  
International Standard Trading Corporation, New York, New York  
Cahart-Farnsworth Corporation, Fort Wayne, Indiana

### Great Britain and Dominions

Standard Telephones and Cables, Limited, London, England  
Branch Offices: Birmingham, Bristol, Leeds, Manchester, England; Glasgow, Scotland; Dublin, Ireland; Cairo, Egypt; Calcutta, India; Karachi, Pakistan; Johannesburg, South Africa; Salisbury, Southern Rhodesia  
Creed and Company, Limited, Croydon, England  
International Marine Radio Company Limited, Croydon, England  
Kolster-Brades Limited, Sidcup, England  
Standard Telephones and Cables Pty. Limited, Sydney, Australia  
Branch Offices: Melbourne, Australia; Wellington, New Zealand  
Silvae Electrical Products Pty. Limited, Sydney, Australia  
Austral Standard Cables Pty. Limited, Melbourne, Australia  
New Zealand Electric Totalisators Limited, Wellington, New Zealand  
Federal Electric Manufacturing Company, Ltd., Montreal, Canada

### South America

Compañía Standard Electric Argentina, Sociedad Anónima, Industrial y Comercial, Buenos Aires, Argentina  
Standard Electrica, S.A., Rio de Janeiro, Brazil  
Compañía Standard Electric, S.A.C., Santiago, Chile

### Europe and Far East

Vereinigte Telefon- und Telegraphenfabriks Aktiengesellschaft Czeija, Nissl & Company, Vienna, Austria  
Bell Telephone Manufacturing Company, Antwerp, Belgium  
China Electric Company, Limited, Shanghai, China  
Standard Electric Aktieselskab, Copenhagen, Denmark  
Compagnie Générale de Constructions Téléphoniques, Paris, France  
Le Matériel Téléphonique, Paris, France  
Les Téléimprimeurs, Paris, France  
C. Lorenz, A.G. and Subsidiaries, Stuttgart, Germany  
Mix & Genest Aktiengesellschaft and Subsidiaries, Stuttgart, Germany  
Süddeutsche Apparatefabrik Gesellschaft m.b.H., Nuremberg, Germany  
Nederlandsche Standard Electric Maatschappij N.V., The Hague, Netherlands  
Fabbrica Apparecchiature per Comunicazioni Elettriche, Milan, Italy  
Standard Telefon og Kabelfabrik A/S, Oslo, Norway  
Standard Electrica, Lisbon, Portugal  
Compañía Radio Aérea Marítima Española, Madrid, Spain  
Standard Eléctrica, S.A., Madrid, Spain  
Aktiebolaget Standard Radiofabrik, Stockholm, Sweden  
Standard Telephone et Radio S.A., Zurich, Switzerland

## Telephone Operating Systems

Compañía Telefónica Argentina, Buenos Aires, Argentina  
Compañía Telefónica Comercial, Buenos Aires, Argentina  
Compañía Telefónica del Plata, Buenos Aires, Argentina  
Companhia Telefonica Nacional, Porto Alegre, Brazil  
Compañía de Teléfonos de Chile, Santiago, Chile  
Compañía Telefónica de Magallanes S.A., Punta Arenas, Chile  
Cuban American Telephone and Telegraph Company, Havana, Cuba  
Cuban Telephone Company, Havana, Cuba  
Mexican Telephone and Telegraph Company, Mexico City, Mexico  
Compañía Peruana de Teléfonos Limitada, Lima, Peru  
Puerto Rico Telephone Company, San Juan, Puerto Rico  
Shanghai Telephone Company, Federal Inc. U.S.A., Shanghai, China

## Radiotelephone and Radiotelegraph Operating Companies

Compañía Internacional de Radio, Buenos Aires, Argentina  
Compañía Internacional de Radio Boliviana, La Paz, Bolivia  
Companhia Radio Internacional do Brasil, Rio de Janeiro, Brazil  
Compañía Internacional de Radio, S.A., Santiago, Chile  
Radio Corporation of Cuba, Havana, Cuba  
Radio Corporation of Porto Rico, San Juan, Puerto Rico

## Cable and Radiotelegraph Operating Companies

(Controlled by American Cable & Radio Corporation, New York, New York)

The Commercial Cable Company, New York, New York<sup>1</sup>  
Mackay Radio and Telegraph Company, New York, New York<sup>2</sup>  
All America Cables and Radio, Inc., New York, New York<sup>3</sup>  
Sociedad Anónima Radio Argentina, Buenos Aires, Argentina<sup>4</sup>

<sup>1</sup> Cable service. <sup>2</sup> International and marine radiotelegraph services.  
<sup>3</sup> Cable and radiotelegraph services. <sup>4</sup> Radiotelegraph service.

## Laboratories

Federal Telecommunication Laboratories, Inc., Nutley, New Jersey  
Standard Telecommunication Laboratories, Limited, London, England

Laboratoire Central de Télécommunications, Paris, France