

BOARD OF DIRECTORS, 1956

- A. V. Loughren, *President*
- Herre Rinia, *Vice-President*
- W. R. G. Baker, *Treasurer*
- Haradan Pratt, *Secretary*
- D. G. Fink, *Editor*
- W. R. Hewlett, *Senior Past President*
- J. D. Ryder, *Junior Past President*

1956

- E. M. Boone (R4)
- J. N. Dyer (R2)
- A. N. Goldsmith
- J. T. Henderson (R8)
- T. A. Hunter
- A. G. Jensen
- J. W. McRae
- George Rappaport
- D. J. Tucker (R6)

1956-1957

- J. G. Brainerd (R3)
- C. R. Burrows (R1)
- J. F. Byrne
- J. J. Gershon (R5)
- Ernst Weber
- C. F. Wolcott (R7)

1956-1958

- E. W. Herold
- J. R. Whinnery

George W. Bailey  
*Executive Secretary*

- John B. Buckley, *Chief Accountant*
- Laurence G. Cumming,  
*Technical Secretary*
- Evelyn Davis, *Assistant to the  
Executive Secretary*
- Emily Sirjane, *Office Manager*

EDITORIAL DEPARTMENT

- Alfred N. Goldsmith  
*Editor Emeritus*
- D. G. Fink, *Editor*
- E. K. Gannett,  
*Managing Editor*
- Helene Samuels  
*Assistant Editor*

ADVERTISING DEPARTMENT

- William C. Copp,  
*Advertising Manager*
- Lillian Petranek,  
*Assistant Advertising Manager*

EDITORIAL BOARD

- D. G. Fink, *Chairman*
- W. N. Tuttle, *Vice-Chairman*
- E. K. Gannett
- Ferdinand Hamburger, Jr.
- E. W. Herold
- T. A. Hunter
- J. D. Ryder



Responsibility for the contents of papers published in the PROCEEDINGS of the IRE rests upon the authors. Statements made in papers are not binding on the IRE or its members.



Change of address (with 15 days advance notice) and letters regarding subscriptions and payments should be mailed to the Secretary of the IRE, 1 East 79 Street, New York 21, N. Y.

All rights of publication, including foreign language translations are reserved by the IRE. Abstracts of papers with mention of their source may be printed. Requests for republication should be addressed to The Institute of Radio Engineers.

# PROCEEDINGS OF THE IRE

*Published Monthly by*

The Institute of Radio Engineers, Inc.

*March, 1956*

VOLUME 44

NUMBER 3

CONTENTS

Scanning the Issue.....	<i>The Managing Editor</i>	294
Poles and Zeros.....	<i>The Editor</i>	295
J. V. L. Hogan, 1956 Medal of Honor Winner.....		296
5650. Color Television Receiver Design—A Review of Current Practice.....	<i>R. G. Clapp, E. G. Clark, George Howill, H. E. Beste, E. E. Sanford, M. O. Pyle, and R. J. Farber</i>	297
5651. The Transfluxor.....	<i>J. A. Rajchman and A. W. Lo</i>	321
5652. The O-Type Carcinotron Tube.....	<i>P. Palluel and A. K. Goldberger</i>	333
5653. IRE Standards on Electron Devices: Definitions of Terms Related to Microwave Tubes (Klystrons, Magnetrons, and Traveling Wave Tubes), 1956.....		346
5654. A New Pressed Dispenser Cathode.....	<i>P. P. Coppola and R. C. Hughes</i>	351
5655. Junction Transistors with Alpha Greater than Unity.....	<i>H. Schenkel and H. Stalz</i>	360
5656. Frequency Modulation Noise in Oscillators.....	<i>J. L. Stewart</i>	372
<b>Correspondence:</b>		
5657. Russian Ionosphere Terminology.....	<i>G. F. Schultz</i>	376
5658. Variation with Temperature of Quartz Resonator Characteristics.....	<i>Rudolf Bechmann and Vera Durana</i>	377
5659. Transfer Ratios of Resistance and RLC Networks.....	<i>A. Talbot</i>	377
5660. Signal-Seeking Devices.....	<i>M. W. P. Strandberg</i>	378
5661. On Passive and Active Networks and Generalized Norton's and Thevenin's Theorems.....	<i>L. A. Zadeh</i>	378
5662. A Note on Local Feedback.....	<i>A. Fuchs</i>	379
<b>Contributors</b> .....		380
<b>IRE News and Radio Notes:</b>		
National Convention Committees.....		382
Convention Technical Sessions Schedule.....		383
Summaries of Technical Papers.....		384
Calendar of Events.....		418
Transactions of the IRE Professional Groups.....		419
Professional Group News.....		425
Technical Committee Notes.....		425
<b>Books:</b>		
5663. "Color Television Receiver Practices," by the Hazeltine Corp. Laboratories Staff... <i>Reviewed by W. P. Boothroyd</i>		426
5664. "Instrument Engineering: Vol. III, Applications of the Instrument Engineering Method; Part One, Measurement Systems," by C. S. Draper, Walter McKay, and Sidney Lees <i>Reviewed by J. G. Truxal</i>		426
5665. "Fundamentals of Television Engineering," by G. M. Glasford. <i>Reviewed by Scott Helt</i>		426
5666. "Transistor Electronics," by A. W. Lo, et al. <i>Reviewed by A. J. Grossman and F. H. Blecher</i>		426
5667. "Principles of Electromagnetism," third edition, by E. B. Moullin. <i>Reviewed by J. R. Whinnery</i>		427
5668. "Color Television Engineering," by J. W. Wentworth. <i>Reviewed by R. P. Burr</i>		427
5669. "Electrons, Waves and Messages," by J. R. Pierce. <i>Reviewed by F. E. Terman</i>		427
Professional Groups.....		431
Sections and Subsections.....		431
5670. Abstracts of IRE Transactions.....		433
5671. Abstracts and References.....		438

ADVERTISING SECTION

Meetings with Exhibits.....	6A	Notes.....	81A	Positions Open.....	300A
News—New Products.....	26A	Professional Group Meetings.....	64A	Positions Wanted.....	320A
IRE People.....	34A	Section Meetings.....	98A	Advertising Index.....	411A
Industrial Engineering.....					

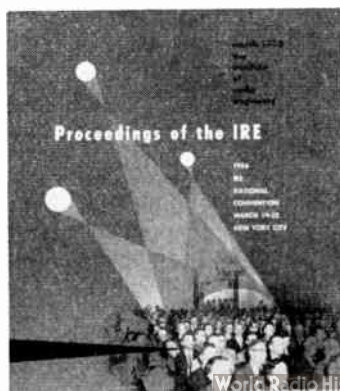

THE COVER—On March 19 the 1956 IRE National Convention will convene in New York City for four days of technical sessions, engineering exhibits and social events. This is the largest technical show and convention in the world and will be of interest and importance to all 48,000 members of the IRE.

The technical program, containing 55 sessions on a wide range of timely subjects, will be highlighted by two special symposia on the U.S. earth satellite program and on color television tape recording. Further details plus abstracts of all papers begin on page 382 of this issue. Also in this issue, starting on page 114A, is "Whom and What to See at the Radio Engineering Show" which gives a complete listing of 714 exhibitors, booth numbers, products to be displayed, exhibit booth personnel and floor plans of the Kingsbridge Armory and Kingsbridge Palace, a valuable preview of a fabulous display covering an entire industry.

## Scanning the Issue



### Color Television Receiver Design— A Review of Current Practice (p. 297)

The first paper in the issue takes a firm grasp of a subject which is of widespread interest and major importance to the electronics industry today—the design of color television receivers. Under the sponsorship of the IRE Professional Group on Broadcast and Television Receivers, design specialists from four companies have pooled their knowledge to present this outstanding survey of design practices currently employed in commercial receivers and have produced a noteworthy addition to the series of invited review papers which now frequent the PROCEEDINGS.

**The Transfluxer** (p. 321)—A novel magnetic core device for controlling and storing electrical signals has been developed which can perform entirely new functions. The transfluxer is similar to conventional core devices in that its output response to an input signal is controlled by a setting pulse which it has previously received and has stored. Unlike other devices, however, the transfluxer output in no way affects the setting pulse; hence, a single setting pulse can be stored—and will control the device indefinitely. In addition to operating in the usual fashion as an “on-off” switch, the transfluxer can also be set to yield an output at any desired level between “off” and maximum “on.” These two attributes mark the transfluxer as an important new component for the computer field. Moreover, it shows promise of finding a wide variety of uses in other fields as a channel selector switch in many multiplexing and switching operations, a peak pulse indicator for nuclear instruments, and a pulse-to-amplitude information converter, to name a few.

**The O-Type Carcinotron Tube** (p. 333)—This paper describes the excellent work that has been carried on in France on a type of backward-wave oscillator in the 1,000 to 12,000 mc range which has a very wide electronic tuning range and moderate power output. In their thorough, yet suitably brief, account the authors present a review of

backward-wave operation, new and useful information on the effects of reflections on frequency, an enlightening comparison of experimental results with theory, and practical design data which indicate that the art has developed to a relatively advanced state—all in all a very important and practical contribution to the field of microwaves.

**IRE Standards on Definitions of Terms Related to Microwave Tubes** (p. 346)—This Standard, which is a product of the IRE Committee on Electron Tubes, brings conformity and clarity to terminology relating to klystrons, magnetrons and traveling-wave tubes.

**A New Pressed Dispenser Cathode** (p. 351)—The latest innovations of L cathodes described in this paper promise to make them of great utility for power electron tubes in the future. The L cathode, like many other cathodes, utilizes a very thin layer of activating material on the emitter surface to stimulate the emission of electrons from the emitter. As the activator slowly evaporates with time, additional activator material is dispensed to the surface from a porous cavity within the emitter where it is stored. The present investigation by the authors of generating and regulating the supply of activator results in a cathode which can be readily mass produced at low cost and which gives high continuous emission currents and long life.

**Junction Transistors with Alpha Greater than Unity** (p. 360)—Junction transistors are normally operated at supply voltages far below the junction breakdown voltage. At these lower voltages not all of the charge carriers injected by the emitter reach the collector due to a recombination of some of the holes and electrons in the base region. As a result, the current amplification, or alpha, is always a little less than unity. However, it has been found that when the collector voltage is raised to a level just below breakdown voltage the charge carriers multiply and the alpha increases to values above unity. By investigating the characteris-

tics and applications of transistors with alpha greater than unity, this paper opens up to the circuit designer an important phenomenon out of which many new uses of junction transistors will appear, especially in the switching field.

**Frequency Modulation Noise in Oscillators** (p. 372)—All oscillator tubes generate a certain amount of internal noise, causing fluctuations in both the amplitude and the frequency of the output wave. The amplitude fluctuations can usually be eliminated by limiters or filters. Certain low-frequency types of fm noise can be avoided, too, by careful design and construction of the tube. However, high-frequency fm noise cannot, in general, be circumvented either by internal tube design or external circuits. Therefore, if there is any kind of discriminator action elsewhere in the system these frequency fluctuations will be converted into amplitude fluctuations and, hence, will add to the noise of the system. This is particularly true of local oscillator noise in many kinds of cw and fm systems. Little has been written on this subject until now because it involves theories on Gaussian noise which have only recently been developed. This paper evaluates for the first time the fm noise output of an oscillator in terms of frequency deviation and spectral bandwidth, and in so doing makes a noteworthy contribution both to modulation theory and practice.

**IRE National Convention Program** (p. 382)—Abstracts are presented of the 270 papers which will be presented at the 1956 IRE National Convention on March 19–22 at the Waldorf-Astoria Hotel and Kingsbridge Armory in New York City.

**Whom and What to See at the Radio Engineering Show** (p. 114A)—This year's list of the 714 Convention exhibitors, booth numbers and products to be displayed has been augmented to include the names of the company representatives who will be on hand in each booth at the Kingsbridge Armory and Kingsbridge Palace to answer your questions.

## Poles and Zeros



**Proceedings vs Transactions—I.** The IRE today publishes no fewer than 26 periodicals, including the PROCEEDINGS and 22 TRANSACTIONS of Professional Groups (the STUDENT QUARTERLY, DIRECTORY and CONVENTION RECORD complete the list). Since a technical paper may be published either in the PROCEEDINGS or in one of the TRANSACTIONS, the IRE publications policy should define their respective spheres of activity. The Editorial Board has wrestled with this question for many months. As a result, the editorial logistics are beginning to emerge with sufficient clarity to justify reporting them here in several installments, of which this is the first.

First, there appears to be general agreement that the IRE is in a period of massive transition, from its pre-war status as a single-state organization with one technical publication to a new-style confederation of groups of specialists, each with its own interests and its own publication. The extraordinary vitality of the Professional Group system needs no emphasis here. It is growing and will continue to grow, not only in number of Groups, but in the size and professional attainment of each Group.

Matching this transition in organizational structure, is a concurrent transition in publications activity. More and more first-rate papers are finding their way into the TRANSACTIONS, papers which in an earlier day would certainly have been published in the PROCEEDINGS.

This trend has posed the inevitable question: "What is the future of the PROCEEDINGS?" Eventually, will all the technical substance of the IRE editorial program gravitate to the TRANSACTIONS? If so, will those many IRE members who have broad interests find that they have to read two dozen periodicals to keep up with the technical times? One view is that the PROCEEDINGS must eventually relinquish its present command of top-grade papers and confine itself to industry and professional news and other such generalities as are common to the whole membership,

leaving technical matters wholly to the Professional Groups.

No one can predict with certainty the steady-state outcome of this growth pattern, but there is evidence that this picture of the future PROCEEDINGS is substantially over-simplified. Consider first the matter of potential readership.

The PROCEEDINGS is sent to over 47,000 members each month; the circulation of the TRANSACTIONS of the largest professional group (that on Electronic Computers) is currently 4,600. Even as the Professional Groups grow, some such 10-to-1 ratio of potential readership in favor of the PROCEEDINGS can be expected to persist, assuming that the IRE as a whole will grow in proportion. While any such ratio persists, the greater scope provided by the PROCEEDINGS will be sought by the technical contributor whenever (as often) he feels that his paper has potential interest outside the confines of a particular Group. Viewed in different perspective, when the editorial reviewers find that a particular paper qualifies for the wider audience, publication in the PROCEEDINGS carries prestige that should not be denied its author. Granted that such considerations carry less weight with the reader than the writer, they certainly go to the substance of which professional societies are made—professional recognition. Most important, the interest of the PROCEEDINGS reader *is* satisfied when the paper *has* broad interest.

This leads to the first article of a sound PROCEEDINGS-cum-TRANSACTIONS policy: Papers published in the PROCEEDINGS should, in one way or another, go beyond the limits of Professional Group interest. There are many different ways in which a paper can so qualify; and this fact is the foundation of a healthy future for the PROCEEDINGS. More on this in P and Z next month.

**Lawful Standards.** Among the unsung heroes of the Institute are those who prepare, review and promulgate IRE Standards. They work in the unglamorous world of precise generalities,

definitions, methods of measurement and the like. These gentlemen should now stop and take a deep bow in behalf of the membership at large, on the occasion of IRE Standards 51IRE17S1 and 54IRE17S1, prescribing the measurement of incidental receiver radiation, having been written into the Federal statutes with the full force and effect of law. This is not only recognition of sound technique; it marks an important milestone in radio regulation and places on our Standards organization a heavy new responsibility.

The background is this: The FCC in December of 1955, after preliminary warm-ups dating back to 1949, formally assumed jurisdiction over an important aspect of the design of radio receivers, namely, their propensity to radiate and thus to interfere with duly authorized interstate communications. This action was a big switch. Up to that date the Commission's authority over equipment design had been confined almost exclusively to transmitters, and it certainly did not extend to such common articles of commerce as fm and television receivers. As of the effective date of the new regulations (printed in full on pages 436-437, this issue) all this is changed. Henceforth the operation of any receiver manufactured after the effective date and tunable in the range from 30 to 890 mc, comes under jurisdiction if the receiver produces incidental radiation greater than 32 to 500 microvolts per meter, depending on the frequency, measured at a distance of 100 feet.

Since the vast majority of the citizens to which this control applies never heard of a microvolt per meter, the new regulations provide that it shall be *illegal* to operate such receivers ("without a station license!") unless they have been certified to meet the prescribed radiation limits and are so marked. The certification may be performed by the owner of the receiver, its manufacturer or the distributor, but in any case it involves a certified measurement of incidental radiation which, say the rules,

(Cont'd. on page 178A)



## John V. L. Hogan

1956 MEDAL OF HONOR WINNER

John V. L. Hogan was born in Philadelphia, Pennsylvania, on February 14, 1890. An early radio amateur, he was laboratory assistant to Lee de Forest in 1906–1907. After graduation from the University School, New Haven, Connecticut, in 1908, he studied electrical engineering at the Sheffield Scientific School of Yale University.

In 1910 he left Yale to become a telegraph engineer for the National Electric Signaling Company, headed by R. A. Fessenden. During the next few years he rose successively to telegraph superintendent, chief of operations, and chief research engineer. In 1917 the company's name was changed to the International Radio Telegraph Company, at which time Mr. Hogan became its manager. He left the firm in 1921 to become a consulting engineer, and in 1929 he became president of Hogan Laboratories, Inc., a firm principally engaged in television and facsimile development. Radio Station WQXR (then W2XR) of New York was founded, owned, and operated by Mr. Hogan from 1934–1944 when *The New York Times* acquired it.

The author of *The Outline of Radio*, Mr. Hogan has contributed through numerous inventions to the radio, television and facsimile fields. He is a member and former Chairman of the Joint Technical Advisory Committee. He is also a member of

the Patent Compensation Board of the U. S. Atomic Energy Commission, and has served on the Special Technical Advisory Group under the Joint Chiefs of Staff and the Department of Defense, and as Chairman of the Panel on Electronic Countermeasures of the Research and Development Board. During World War II he was Special Assistant to Vannevar Bush, Head of the Office of Scientific Research and Development, with cognizance of communications, radar, countermeasures and guided missiles.

One of the three original founders, he helped to combine the Society of Wireless Telegraph Engineers and the Wireless Institute to form the IRE. In 1915 he became a Fellow, and in 1920, President. In addition, he has served on many committees and on the Board of Directors. The IRE Medal of Honor, the highest technical award in the radio engineering profession, now will be given to Mr. Hogan "for his contributions to the electronic field as a founder and builder of The Institute of Radio Engineers, for the long sequence of his inventions, and for his continuing activity in the development of devices and systems useful in the communications art." The award will be presented at the national convention banquet, at which he will be the guest speaker.

# Color Television Receiver Design—A Review of Current Practice\*

R. G. CLAPP†, SENIOR MEMBER, IRE, E. G. CLARK‡, ASSOCIATE MEMBER, IRE,  
 GEORGE HOWITT§, MEMBER, IRE, H. E. BESTE§, E. E. SANFORD§,  
 ASSOCIATE MEMBER, IRE, M. O. PYLE||, MEMBER, IRE,  
 AND R. J. FARBER¶||, SENIOR MEMBER, IRE

The following paper is one of a planned series of invited papers in which men of recognized standing will review recent developments in, and the present status of, various fields in which noteworthy progress has been made.

As the title indicates, this paper has been restricted to current practices. We are greatly indebted to the IRE Professional Group on Broadcast and Television Receivers, which sponsored this paper, and to J. D. Reid and W. P. Boothroyd, under whose editorship the various sections were prepared and coordinated.

—The Editor.

**Summary**—This review of current practice in color receiver design covers the most usual circuit combinations which have found a place in commercial receivers. Further circuit standardization in all basic functions is clearly indicated and may be predicted through the next year. It may also be expected that wide usage of color receivers may revise present performance requirements and in turn introduce further circuit revisions.

## I. INTRODUCTION

### A. Elements of Compatible Color Television Receivers

THE AIM of this paper is to present a review of current practice in the design of color television receivers. It is assumed that the reader is familiar with the FCC standards.<sup>1</sup> Many parts of receivers designed for these standards are very similar to those of monochrome receivers although even in these parts, reception of color signals imposes a few special requirements on the circuits. Examples are the IF amplifier, which must have adequate response at the color carrier frequency and must be free of nonlinearity effects like subcarrier rectification and cross modulation; or the horizontal sync circuits which must have better phase stability than in a monochrome receiver. Other parts although superficially similar to their monochrome counterparts actually differ from them enough to require completely new designs. The second detector, which is sometimes split into two detectors, or the deflection yoke, which has requirements associated with the picture tube, are examples of this category. Still other parts

have no monochrome counterparts at all. Examples are the circuits required to convert the composite color video signal into signals suitable for application to the picture tube grids, and the color picture tube itself. In many parts of the set, several alternative circuit arrangements are possible. This paper attempts to discuss all the above areas of the set to indicate where the requirements of a color set differ from those of a monochrome set, and to present several alternatives in parts where such are common. This paper will deal exclusively with receivers for shadow mask type picture tubes as this type is presently the only one in extensive use.

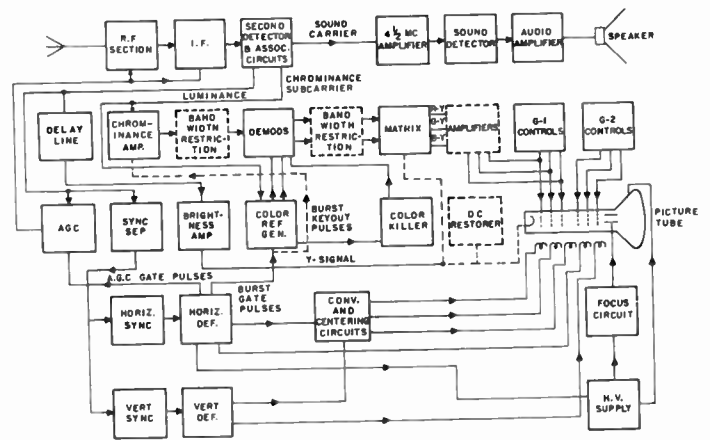

Fig. 1—Block diagram, typical color receiver.

Fig. 1 is a block schematic of a typical color television receiver. It shows principal parts of set and is generalized to include some of the more usual alternative circuit arrangements. All parts and means for testing and adjusting many of them are discussed in detail here.

Following the path of signals through the receiver,

\* Original manuscript received by the IRE, December 13, 1955.  
 † Philco Corp., Philadelphia, Pa.  
 ‡ Formerly Philco Corp., now with Burroughs Corp., Paoli, Pa.  
 § Allen B. Du Mont Labs., 2 Main Ave., Passaic, N. J.  
 ¶ RCA Service Co., Inc., Cherry Hill, Camden, N. J.  
 || Hazeltine Corp., 59-25 Little Neck Pkwy., Little Neck, L. I., N. Y.  
<sup>1</sup> Second color television issue of PROC. IRE, vol. 42; January, 1954, including NTSC Signal Specifications, pp. 17-19.

the first section, of course, is the rf section or tuner. It differs only slightly from those used in monochrome practice.

Next is the IF section. Intercarrier sound circuits are universally used today, so no separate sound IF is shown. The circuitry included in the block marked "second detector" can take a number of forms, although in all cases the input to this section is IF and the outputs are a 4.5 mc carrier modulated with sound, a 3.58 mc carrier modulated with chrominance and a luminance signal in the frequency range from dc to about 3.5 mc.

To complete the sound channel, the 4.5 mc signal goes through an amplifier to an fm detector and the audio output of the detector goes through an amplifier to the speaker. The circuits which make use of the luminance and deflection synchronizing portion of the signal are almost identical in many respects with those of a monochrome receiver. The function of one of these circuits is to provide agc voltages for the rf and IF sections. The distribution of agc in a color set is more critical than in a monochrome set and requires special attention. AGC is customarily gated by pulses from the horizontal deflection circuits. The synchronizing functions indicated by the blocks marked sync separator, horizontal sync, and vertical sync, are like those of a monochrome receiver, except that it is desirable to build more phase stability into the horizontal sync in a color set since one of its vital functions is to provide burst key-out pulses to some chrominance amplifiers and burst gate pulses to the color subcarrier reference generator; and the performance of the latter can be seriously degraded by poor horizontal sync.

The function of the luminance signal, to provide information for the display, is accomplished by the blocks marked delay line, luminance amplifier and dc restorer. The luminance amplifier is a typical video amplifier except that it should not transmit the frequency of the color carrier, 3.58 mc, to the display. The delay line is required because the bandwidth of the chrominance channel of the set is much narrower than that of the luminance channel and, consequently, its time delay is greater. Signals through the two paths must arrive at the picture tube at the same time. The delay line equalizes the delays of the two paths. DC restoration or dc coupling are more commonly employed in color sets than in monochrome because both the hue and saturation of the color pictures can be affected by an incorrect dc component of the  $Y$  or luminance signal. The luminance signal can be fed to the cathode of the picture tube as a  $Y$  signal or to the grids as one part of the  $R$ ,  $G$ , and  $B$  signals.

The functions involving the chrominance signal have no counterpart in monochrome receivers. These are: amplification of the chrominance signal; demodulation of the phase and amplitude modulated chrominance signal into video components by demodulators activated by the color reference generator; bandwidth re-

striction before or after demodulation; different degrees of bandwidth restriction in some cases in the different channels out of the demodulators; and a matrix unit whose outputs are  $R$  or  $(R - Y)$ ,  $B$  or  $(B - Y)$  and  $G$  or  $(G - Y)$  video signals suitable for application to the 3 grids of a picture tube. The presence of the matrix unit allows any one of a variety of demodulating systems to be used, since the outputs of two synchronous demodulators at different phases can always be rearranged by linear operations into  $R - Y$ ,  $B - Y$ , and  $G - Y$ . Amplification of these signals after the matrix operation is also possible.

The color subcarrier reference generator makes use only of the burst portion of the chroma signal. It is activated by a burst gate pulse from the horizontal deflection circuits only during the time the color burst is expected. It converts the burst into a continuous sine wave, coherent in frequency with the burst, and as free of contamination by noise and video as possible. This sine wave forms the phase reference signals in the phases required by the synchronous demodulators.

The function of the color killer is to disable automatically the color demodulators when receiving monochrome signals. It is activated by the absence of the color burst. Its purpose is to prevent noise or signal components in the high frequency portion of the video spectrum of a monochrome signal from appearing on the screen as low frequency color variations in monochrome pictures.

The horizontal and vertical deflection circuits do not differ functionally from those of monochrome receivers except in having outputs peculiar to color receivers such as burst gate pulses, outputs to convergence circuits, and the higher power delivered to the high voltage supply because of the requirements of the picture tube.

The remaining functions shown in the block schematic are peculiar to the color display or materially affected by it. These are the bias controls for the 3 control grids ( $G_1$ ) and 3 screen grids ( $G_2$ ) of the three-gun tube, the special yoke required by the tube, the convergence, centering and color purity circuits and coils required by the tube, the special high voltage and electrostatic focus circuits, and, of course, the three-gun shadow mask tube itself. In addition to the factory-adjusted controls shown in the diagram, there are customer-operated controls on brightness, contrast, saturation and hue. The locations and interrelationships among these controls are of concern to the color receiver designer and are discussed further in this paper.

### B. Classification of Receivers

To summarize the various types of circuitry and devices which make up the block diagram of Fig. 1, receivers may be classified in several ways.

*Detector and Separation of Luminance, Chrominance, and Sound Channels:* Two principal types of receiver are common: those in which there is one second detector, with separation of the luminance, chrominance, and

sound signals by video frequency selective circuits following the detectors; and those in which the IF amplifier is split into two or more channels immediately preceding the second detector or even earlier in the IF amplifier, with second detectors in each of the channels and appropriate amplifiers and selective circuits following the detectors.

The various forms which this portion may take include: a single detector for luminance, chrominance and sound; separate detectors for picture and sound; or a separate detector for luminance on the one hand and chrominance and sound on the other. Any of these channels may also have amplifier stages before or after detection, not common with those of other channels. Several of these arrangements offer design freedom not possible with the common detector arrangement.

*Color Processing Arrangement:* Receivers can be classified into two principal types: those which demodulate the chrominance signal into  $I$  and  $Q$  signals which are then subjected to different degrees of bandwidth restriction; and those which demodulate into any one of various combinations of two signals which then pass through circuits of equal bandwidth. Only the first type makes full use of the information contained in the signal. In either case, the demodulator outputs are rearranged by linear matrix operations into  $R-Y$ ,  $B-Y$ , and  $G-Y$ .

*Color Reference Generator Arrangements:* Three fundamental types of reference generator circuit exist: the oscillator-reactance tube phase detector system, the high- $Q$  filter system, and the oscillator locked by direct injection. The second always employs a quartz crystal as the filter, and the first and third types may also employ a quartz crystal to stabilize the oscillator. The fundamental difference between the types is in the presence of active oscillator elements in the first and third types, whereas the second consists of a passive resonator with gates and amplifiers.

*Functions and Components Unique to Color Displays:* These functions and components include the controls on the first and second grids of the three guns, the focus and high voltage supplies, the yoke and the convergence, centering and purity circuits and coils. Receivers can be classified in these areas by stating what shadow mask tube they use, for the choice of the tube dictates the designs of all these circuits and components.

Broadly speaking, the requirements which the shadow mask tube puts on its associated circuits and components can be grouped in the following classifications: the characteristics of the three guns must be tracked with each other so that there is no undesired hue shift with brightness. This may require separate controls on the gains,  $G_1$  biases and  $G_2$  voltages in the three channels.

The three beams must converge properly and strike only the proper phosphor dots all over the face of the tube. This requirement dictates the design of dynamic convergence circuits, color purity circuits, and magnetic shielding or other arrangements to prevent the earth's

or other magnetic fields from affecting color purity. Electrostatic convergence electrodes may be employed, as well as magnetic devices.

Adequate high voltage power and a regulated focus voltage must be provided to give the desired brightness with good definition. The inherent relative inefficiency of the shadow mask and the characteristics of known color phosphors make it necessary to provide more high voltage power for a given light output than would be required for a monochrome tube.

## II. CIRCUIT FUNCTIONS SIMILAR TO MONOCHROME RECEIVER PRACTICE

### A. RF and IF Amplifiers

The spectrum of the color television transmission contains the color subcarrier as an additional component not found in the monochrome signal. This additional signal contains components above and below the subcarrier frequency. The subcarrier is 3.58 mc above the picture carrier. The composite rf color signal is delivered to the receiver input which must process these modulation components linearly and deliver them to the color picture tube. While in a monochrome receiver treatment of the high video frequency region of the signal affects only the fine structure of the picture, in a color receiver more critical handling of the subcarrier region is required to preserve color fidelity. Improper rf or IF passbands in the vicinity of the modulated subcarrier can result in poor color performance before any appreciable degradation in monochrome picture quality is detectable. Because the signal is largely single sideband and may have a high depth of modulation, additional precautions must be taken to prevent non-linearity from generating undesirable cross modulation and rectification effects. These two general considerations, bandwidth and linearity, furnish the differences in design criteria for the monochrome and color receiver rf and IF amplifiers.

The tuner performs the same function of selection of the rf signal and conversion to IF for both color and monochrome transmissions. Since the amplitude relation of the chrominance and luminance signals contains color information, it is desirable to maintain the same relative response to the rf subcarrier and picture carrier from channel to channel. Failure to do so may require readjustment of the chrominance amplifier gain or place an additional burden on the automatic color control, if used. The usual production acceptance limits for monochrome tuner responses of  $\pm 3$  db over the channel may be reduced to a typical value of  $\pm 1.5$  db for color. For the same reason, impedance match between tuner and transmission line is more critical for color reception.

The local oscillator frequency stability tolerance may be as severe as  $\pm 50$  kc in a color receiver employing a common luminance-chrominance detector. This is for the purpose of keeping the sound carrier in the notch

of the IF traps in order to control the 920 kc sound-chrominance beat. The initial trend toward receivers where the luminance and chrominance signals were taken from separate detectors (Fig. 2) was partly to permit relaxation of the local oscillator tolerance and to make customer adjustment less critical.

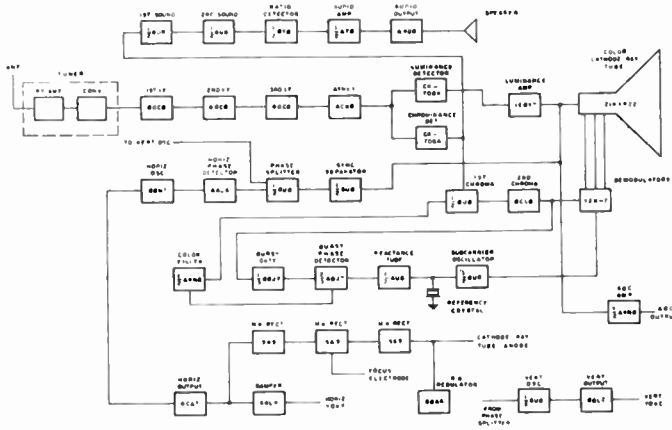

Fig. 2—Functional diagram, dual detector receiver.

A current practice is to take the luminance signal from an individual detector and the chrominance signal from another detector which is also used to obtain the 4.5 mc intercarrier sound signal. Fig. 3 illustrates a detector circuit employing transformer coupling to the luminance channel with the signal for the chrominance-sound detector taken off ahead of this coupling. An advantage of this arrangement is that the chrominance detector does not require deep sound trapping which makes it easier to obtain good amplitude and phase responses in the region of the chrominance sidebands. In addition, the IF response to the luminance detector need not include full response to subcarrier and the design of the sound traps is made easier.

The IF sound carrier and chrominance subcarrier beat with each other to produce an output from the luminance detector at the video difference frequency of 920 kc. This beat frequency must be kept at a sufficiently low level to prevent the formation of an objectionable pattern on the screen during the transmission of saturated colors. The 920 kc beat cannot be rejected in the luminance amplifier and must be controlled by reducing the IF sound carrier level to such an extent that it has a negligible effect on the detection process. The 920 kc beat at the luminance detector is proportional to the product of the levels of the IF sound carrier and the IF chrominance subcarrier. This means that the relative decibel responses at these two frequencies can be added and make it possible to state the attenuation requirement in terms of the combined sound and subcarrier attenuation. In order to reduce the 920 kc beat to 40 db below the maximum monochrome signal for the most severe signal condition, a combined attenuation of approximately 40 db below picture carrier is required.

To achieve the combined requirements of maximum IF bandwidth and high sound carrier attenuation, four-terminal coupling circuits have been widely employed. These four-terminal networks are usually of the non-minimum-phase type and are capable of furnishing very steep-sided trap characteristics with a good gain-bandwidth product. Typical of such circuits is the bifilar *T* trap circuit developed by Fisher and Avins<sup>2</sup> and illustrated in Fig. 3. The bifilar *T* trap circuit is inductively coupled to the fourth IF plate inductance and provides an additional 32 db rejection at 41.25 mc for the luminance detector. A resistor across one-half the bifilar transformer reflects a negative resistance into the branch circuit which can be adjusted to compensate for the equivalent series resistance of the trap at its resonance. This circuit differs from conventional arrangements in that no "after response" is introduced by the trap. The complete circuit includes the chrominance-sound detector which is coupled through a small capacitor to the last IF amplifier plate inductance. To provide protection against 920 kc appearing in the demodulated output of the chrominance channel, two 4.5 mc traps are provided in the output of the chrominance detector. One of these is a bridged *T* trap which has a closely-coupled secondary to provide the 4.5 mc intercarrier sound takeoff.

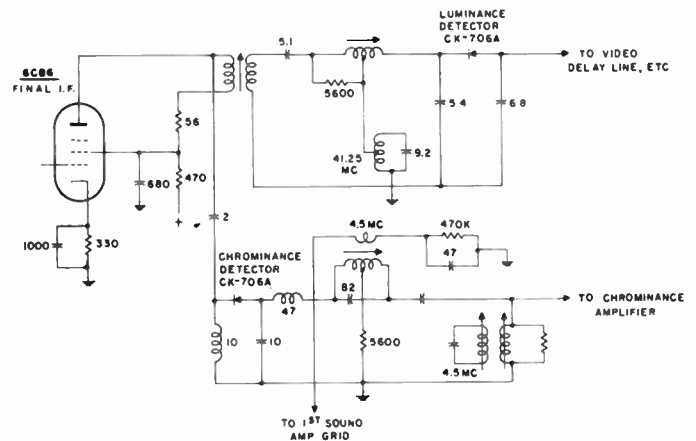

Fig. 3—Dual detector circuit.

A single detector for luminance, chrominance, and sound has been employed in very early and very recent color receivers (Fig. 4). The detector simplification may justify the attendant design difficulties and additional burdens on subsequent amplifiers. The previously stated requirements for total chrominance-sound attenuation can be obtained by placing the chrominance subcarrier on a sloping portion of the passband to the detector (Fig. 5). The relative attenuations are design choices determined principally by the required luminance and chrominance signal bandwidths, the ability of the chrominance amplifier to compensate for the non-flat IF response, and the available 4.5 mc intercarrier sound

<sup>2</sup> B. Fisher and J. Avins, "An analysis of the bifilar-T trap circuit," RCA LB-961, September 16, 1954.



gain. As mentioned previously, single detector systems usually exhibit more criticalness to local oscillator mistuning than dual detector systems.

RF and IF responses producing substantially greater gain for the chrominance subcarrier than for picture carrier should be avoided. Otherwise, high saturation colors where chrominance subcarrier amplitude is high can produce high modulation single-sideband detection ("subcarrier rectification")<sup>3</sup> with the resulting reduction in luminance. In extreme cases, the luminance value of a highly saturated primary color can be less than that of black.

Because amplifier nonlinearity can introduce objectionable cross modulation between picture carrier and chrominance subcarrier or even detection and remodulation of the 920 kc beat, IF tube transfer characteristics are more important in color receivers than in monochrome receivers. Several new tube types have been introduced featuring high transconductance and remote cutoff or "super control" to combine high sensitivity with desirable agc control characteristics. Typical of these are the 6BZ6 and the 6DC6.

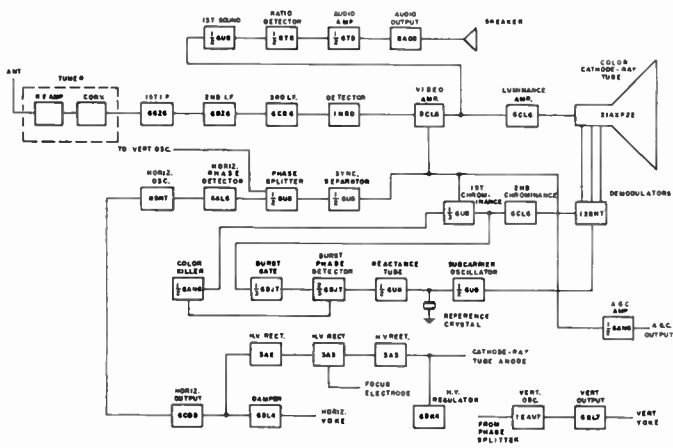

Fig. 4—Functional diagram, single detector receiver.

**B. Video Amplifier**

In a color television receiver employing the dual detector system described above (Fig. 2), the video amplifier handles only the luminance signal and its requirements are considerably relaxed over systems where luminance and chrominance are simultaneously amplified. The simplification of the video amplifier requirements constitutes another advantage of this form of second detector circuit.

The desired frequency response of the video amplifier is approximately flat to 3.0 mc, with 10 db to 20 db of rejection at the subcarrier frequency 3.58 mc. The requirement for subcarrier rejection is not only to prevent the appearance of a 3.58 mc dot pattern, which may be

considered objectionable, but also to eliminate the crawling pattern which is produced by the beat between the subcarrier and the phosphor dot pattern. In addition, subcarrier superimposed on the luminance signal can lead to a desaturation of colored areas due to rectification by the electron gun grid curvature. If the response does not provide a gentle roll-off in the vicinity of subcarrier, a poor luminance transient will result and, in addition, the subcarrier sidebands may not be sufficiently attenuated to prevent dot crawl and rectification effects along colored edges in the picture.

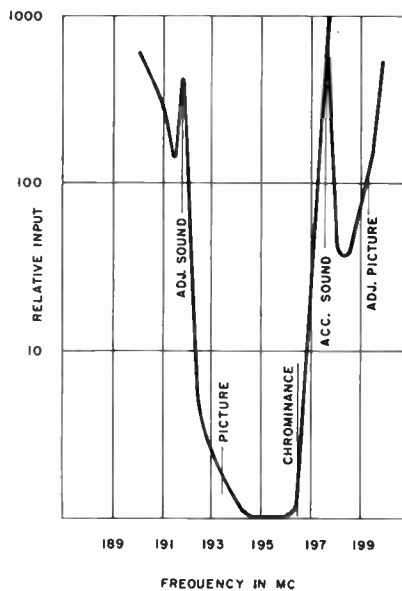

Fig. 5—Bandpass response to single detector.

Because the spot size in color receiver picture tubes is considerably larger than in typical monochrome picture tubes, a greater amount of video and IF overshoot is tolerable. In fact, a judicious amount of preshoot may even be desirable to enhance apparent resolution.

Because the chrominance channel bandwidth is typically 0.6 to 0.7 mc compared to the luminance bandwidth of approximately 3.5 mc, the chrominance signal experiences considerably more time delay. In order to assure time coincidence, or registry, of the two signals at the picture tube, it is necessary to provide delay equalization in the form of increased delay in the luminance channel. The delay line of Fig. 6 may be a commercially available flexible delay cable with a characteristic impedance of 4,100 ohms, a delay value of 1.0  $\mu$ sec per foot, and substantially linear phase and uniform amplitude response over the transmission range of the luminance channel. The luminance delay should be about 0.8  $\mu$ sec. Delay "sticks," or semi-distributed delay lines on rigid forms, are also likely to find application.

A nonlinear video amplifier transfer characteristic will produce, in addition to the usual monochrome effects, a distortion of the saturation of color signals. The same is true with respect to reproduction of the luminance dc component, but because the viewer lacks

<sup>3</sup> F. L. Fredendall and W. C. Morrison, "Effect of transmitter characteristics on NTSC color television signals," PROC. IRE, vol. 42, pp. 95-105; January, 1954.

an accurate frame of reference for the saturation of televised signals, accurate rendition of saturation is of less importance than that of hue, and the color receiver video amplifier becomes not much different in these respects from monochrome. The direct coupling of the circuit of Fig. 6 results in only partial reproduction of the dc component, due largely to the high conductance loading of the three electron gun cathodes. This loading is of sufficient magnitude to alter the video peaking requirements as well.

Early receiver practice was to design a contrast control which provided equal change in luminance and chrominance and therefore maintained constant saturation. Considerable receiver simplification can be obtained by placing the contrast control in the luminance channel only. Because a separate saturation, or "color," control is necessary with either arrangement, there is considerable justification for the latter system. The most notable departure of this circuit from typical monochrome practice is in the use of the null-tee trap and delay line combination arranged so that the trap compensating resistor also serves as the detector load and the delay line termination.

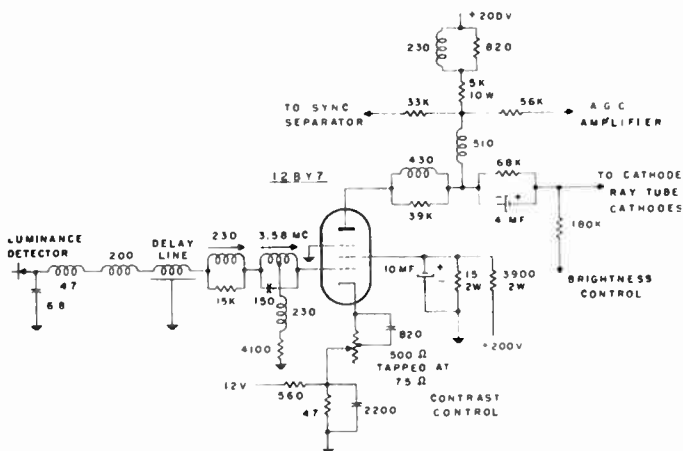

Fig. 6—Video amplifier, dual detector receiver.

In receivers employing a single detector for chrominance, luminance, and sound, the video amplifier is usually required to simultaneously amplify these signals to overcome the relatively low chrominance and 4.5 mc sound carrier outputs. The transfer characteristic of the video amplifier must be chosen for sufficient excellence of linearity to prevent subcarrier rectification or other forms of crosstalk. One recent circuit employs a "bootstrap" connection of the combined detector between grid and cathode of the video amplifier (Fig. 7). This permits amplification to a load which serves as a chrominance, sound, and sync take-off and to a load which is the luminance delay line. Great care must be taken in such an arrangement to assure a low impedance return from the detector for the IF carrier and its harmonics.

### C. Sync and AGC

The automatic gain control and synchronizing requirements for the color television receiver are only slightly different from monochrome. As mentioned above, the susceptibility of the color television IF to cross modulation and the use of super control IF tubes increases the desirability of amplified agc such as the keyed system indicated in Fig. 2. The use of the horizontal flyback pulse for burst gating adds an additional requirement to the horizontal oscillator phase accuracy. For this reason it may also be necessary to restrict the range of the horizontal hold control.

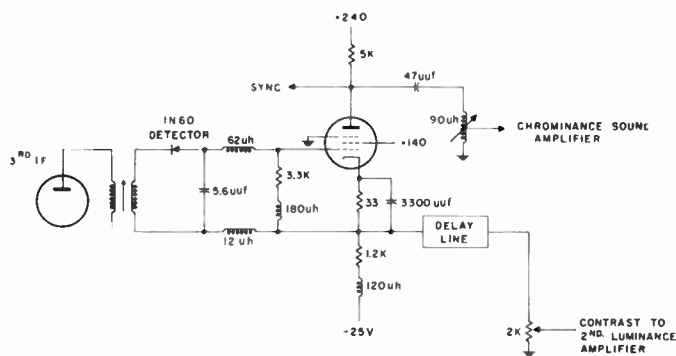

Fig. 7—Video amplifier, single detector receiver.

### D. Horizontal Deflection and High Voltage

In order to produce acceptable picture brightness, the color receiver must be capable of delivering sufficient high voltage power to the color tube to overcome the losses due to interception of current by the shadow mask. The high deflection power required by the low sensitivity color yoke makes possible the combination of an efficient flyback high voltage supply with an energy recovery type horizontal deflection system. The problem in such a circuit is preventing the considerable change in high voltage load with luminance from upsetting linearity, scan width, and focus. In the circuit illustrated in Fig. 8, a triode shunt regulator is employed to provide an essentially constant high voltage load. Although with the exception of increased power levels and high voltage regulation (convergence circuitry is covered elsewhere), the color deflection circuit closely resembles conventional monochrome practice, the details of the typical circuit are probably of sufficient interest to warrant further description.

The color yoke is of special design with a horizontal winding inductance of approximately 12 millihenries. With a deflection angle of 70 degrees and an anode voltage of 25 kv, 1.8 amperes peak-to-peak is required for full scan. The horizontal auto-transformer is of conventional form, except that it is designed somewhat more conservatively for core flux density than is usual with lower power monochrome circuits and is larger physically. The driver to yoke turns ratio has been

given<sup>4</sup> as 1.7:1 with a secondary inductance of approximately 130 millihenries. The damper is tapped up on the transformer where its pulse is approximately 10 per cent higher than that at the yoke. Both linearity and width controls are of conventional design.

The high voltage supply is designed to deliver the 4,500 volt focus voltage and the 25 kv anode voltage, the latter at currents up to 800  $\mu$ amp. A diode-coupled doubler circuit provides the low impedance anode supply while minimizing the voltage rating requirements on transformer, components, and rectifiers. A bleeder driven from input rectifier supplies focus voltage.

High voltage regulation is generally obtained by the use of a special tube such as the 6BK4 triode. Corona type regulator tubes also have been used. The triode regulator operates as a variable current load actuated by a grid signal divided from the high voltage output. With the extremely high  $\mu$ 's available in the tube types developed for this application,  $\pm 5$  per cent regulation can be obtained over the range of zero to 800  $\mu$ amp.

In addition to the special high voltage regulators, several other new tube types have been introduced to meet the special high current requirements of the color deflection and high voltage circuits. These include the 6CB5 output tube, the 6BL4 damper, and the 3A2 and 3B2 high voltage rectifiers.

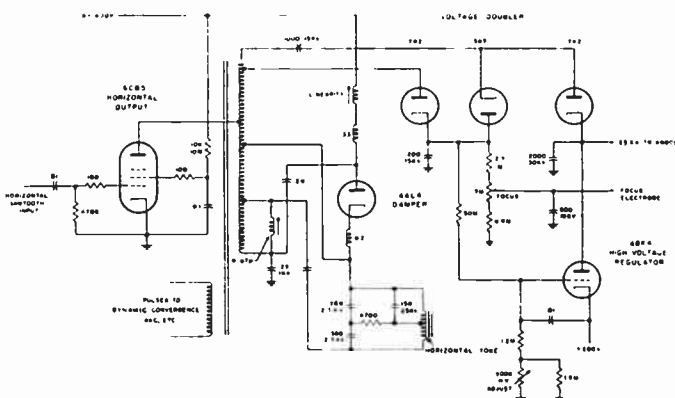

Fig. 8—Horizontal deflection and high voltage.

### E. Other Circuits

The sound system following the 4.5 mc take-off of the type illustrated in Fig. 3 is of conventional design since the color receiver introduces no special audio requirements. Other techniques of 4.5 mc sound beat take-off usually involve different detector arrangements.

The vertical deflection amplifier must provide higher power and dynamic convergence (described elsewhere), but is also conventional. Because a high  $B$  supply voltage on the order of 400 volts is required for the horizontal scan in a color receiver, it is economical to employ a triode vertical deflection amplifier.

The low voltage power supply must produce more power than conventional monochrome receiver. Several new full-wave vacuum rectifier tubes such as the type 5AU4 have been designed for the higher current operation typical of the color receiver. A typical receiver might employ a selenium voltage doubler system operating from a plate transformer and providing +200 and +400 volts. The ac input power for this receiver would be approximately 300 watts.

## III. CIRCUIT FUNCTIONS UNIQUE TO COLOR RECEIVERS

### A. Color Synchronization

In order to recover the color information contained in the video signal, it is necessary for every receiver to provide a local source of continuous color reference signal for application to the chrominance demodulators. This reference signal provides the frequency and phase standard for the receiver. In order to accomplish this, frequency and phase reference information is transmitted as a component of the composite video signal. This color synchronizing information is in the form of a color burst, which consists of eight or nine cycles of color sub-carrier frequency immediately following each line synchronizing pulse. It is the function of the color synchronizing circuits to synthesize the local color reference signal from the information provided in the color synchronizing signal and to maintain it in fixed phase with respect to the color burst.

A block diagram for a typical color synchronizing system is included in Figs. 2 and 4. The burst is time-separated from the composite video signal by the burst separator and is applied to the color reference generator. The reference generator uses the burst signal to create a continuous reference signal of the proper phase and frequency. Most common circuits for doing this are a burst excited tuned circuit (ringing circuit) and an oscillator with appropriate frequency and phase control.

The important parameters of any color synchronizing system are: the static phase error, the changing or dynamic phase error, the stabilization time, and the frequency lock-in range. These aspects of color synchronization are discussed in the following paragraphs.

**Static Phase Error:** The static phase error is a measure of how exact the phase synchronism between the color burst and the reference signal is. In a linear, noiseless channel, the burst signal may be located in phase, with precision limited only by the gain of the system. It is desirable to establish tolerances on the exact phase synchronism required. Flesh tones and commercial product packagings are quite familiar to the general public and a reasonable degree of fidelity will be expected. It has been found in various laboratories<sup>5,6</sup> that

<sup>5</sup> W. G. Ehrich and M. I. Burgett, "A physical and subjective study of hue and luminosity variations in constant luminance systems," Philco Res. Div. Rep. #220; July, 1952.

<sup>6</sup> D. L. MacAdam, "Quality of color reproduction," Proc. IRE, vol. 39, pp. 468-485; May, 1951.

<sup>4</sup> M. J. Obert, "Deflection and convergence of the 21-inch color kinescope," RCA Rev., vol. 16, pp. 140-169; March, 1955.

a static phase error of  $\pm 10^\circ$  is acceptable to most observers. A static phase error of  $\pm 20^\circ$  is easily seen and is not tolerable as reference to a color plate in the literature will show.<sup>7</sup>

A good static phase error figure to use for color synchronizing circuits is  $\pm 5^\circ$ , as the rest of the transmitter-receiver system will most certainly use up the remaining allowable tolerance. The long term static phase error for the color sync circuit may be somewhat greater if a phasing control is available to the observer.

**Dynamic Phase Error:** In the presence of noise, the phase data obtained from the signal will fluctuate and the color synchronizing performance will be impaired. Therefore, an important aspect of the performance of a color synchronizing system is how well the effects of noise are reduced. Impulse noise and noise intermediate between impulse and thermal, have a high degree of predictability and may be removed to a large extent by amplitude and time selection. Thermal noise during the burst interval is the most difficult to discriminate against and, in fact, this may be done only by averaging. Thermal noise performance is therefore used as a criterion in evaluating color synchronizing systems.

Since thermal noise is random, the average obtained by integrating over a suitable length of time is zero. The signal, due to its repetitive nature, however, will produce a finite average. This process permits many successive observations of phase to produce a single averaged result. Therefore, the phase error due to noise will vary as the inverse of the square root of the number of observations; *i.e.*, for a system with a fixed bandwidth, the error varies inversely as the square root of the integration time  $T_1$ .

The root-mean-square variation of the phase in the local color-carrier reference signal is a good measure of how a particular circuit is affected by thermal noise. It may be shown that in a receiver, the rms phase error may be given as<sup>8</sup>

$$\phi_{\text{rms}} = \frac{1}{3 \frac{S}{N} \sqrt{T_1}},$$

where

$\phi_{\text{rms}}$  is the rms phase error in degrees,

$S$  is the peak-to-peak voltage amplitude of line sync,

$N$  is the rms thermal noise voltage in the bandwidth  $B$ ,

$T_1$  is the effective integration time in seconds.

This relationship is plotted in Fig. 9 for values in the region of minimum useful signal to noise ratios. It may be seen that as the signal to noise ratio decreases, the

rms phase error may be kept constant if more integration time,  $T_1$ , is allowed.

Since  $S$  represents 25 per cent of peak carrier and since for Gaussian noise the "peak" value is approximately 4 times the rms value,<sup>9</sup> it may be seen that for unity  $S/N$ , the "peak" noise equals the peak carrier amplitude. For a television tuner with a 6 db noise figure, the unity signal to noise ratio just described corresponds approximately to a 35 microvolt signal on a 300 ohm antenna. This is in the order of the sensitivity of present monochrome receivers and, therefore, the color synchronizing system should provide satisfactory action with  $S/N$  ratios of unity. Under these conditions, when the rms phase error is  $\pm 5^\circ$  or smaller, it has been found that the color sync noise disappears in the video noise. From Fig. 9 (taken from Richman<sup>8</sup>) it may be seen that this will require an integration time,  $T_1$ , in the order of 5,000 microseconds. Since the line period is 63.5 microseconds, this is approximately 80 successive color bursts. This indicates the length of time over which the color synchronizing system must integrate at low signal to noise ratios to provide satisfactory operation.

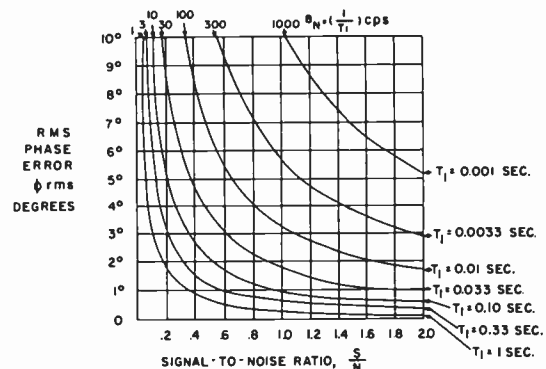

Fig. 9—Reference system dynamic phase error vs signal to noise ratio.

**Stabilization Time:** The time which color synchronizing circuits take to reach their final value after interruptions such as channel switching, encoder switching, etc. should be such that it appears instantaneous to the observer. If the stabilization time is of the order of magnitude of 1 second or less for maximum subcarrier detuning, above requirement is met for most observers.

**Frequency Lock-In Range:** This is the maximum frequency detuning from which the system will achieve the desired final operating condition.

**Gating:** In order to utilize the burst information properly, it must be time separated from the color signal. This may be done conveniently by using the horizontal flyback pulse, which has been suitably delayed and shaped, as a gate pulse. The delay is necessary to make the flyback pulse occur in time at the same point as the burst. It is desirable to flatten the top of the flyback pulse so that the burst envelope is not altered by the

<sup>7</sup> *Electronics*, vol. 25; February, 1952, front cover.

<sup>8</sup> D. Richman, "Color-carrier reference phase synchronization accuracy in nts color television," *PROC. IRE*, vol. 42, pp. 106-133; January, 1954.

<sup>9</sup> V. D. Landon, "The distribution of amplitude with time in fluctuation noise," *PROC. IRE*, vol. 29, pp. 50-55; February, 1941.

pulse shape. The burst amplifier stage is driven from a source of chrominance signal and is biased so that it conducts only during the keying pulse and therefore amplifies only burst.

Alternatively, arrangements exist where the burst is amplified in common with the chrominance signal, as opposed to a separate burst amplifier. Here it is possible to pass only the burst into the subcarrier generator by using a keyed switch such as a pulsed diode.

### B. Reference Oscillator System

*Sync:* The two techniques for color synchronization which may be of interest are passive integrators *i.e.*, ringing circuits, and locked integrators *i.e.*, automatic phase and frequency controlled oscillators (APFC).

1) *Passive:* An arrangement of a ringing circuit would include a burst gate, a passive filter circuit, and an amplitude limiting stage. The burst from the gate amplifier excites the tuned circuit, which produces a damped wave train for the duration of the line. Clippers are then used to produce the constant amplitude output required. The ringing circuit is fundamentally a narrow band filter at the subcarrier frequency which filters out the fundamental frequency from the burst spectrum.

The static phase error of this type of circuit is a function of the frequency detuning and the circuit  $Q$ .

Assuming a signal to noise ratio of unity, the integration time,  $T_1$ , required for a dynamic phase error of  $5^\circ$  is .005 second from Fig. 2. The noise bandwidth  $B_N$  associated with the integration time is  $1/T_1$ . For this case, it is 200 cps. The noise bandwidth of a tuned circuit is given by  $\pi/2$  times the 3 db bandwidth or:

$$B_N = \frac{\pi}{2} \frac{f_0}{Q}$$

Therefore, for a 200 cps noise bandwidth, a tuned circuit  $Q$  of 28,000 is required. This value of  $Q$  rules out LC tuned circuits and restricts this type of circuit to crystal resonators. A typical crystal ringing circuit is shown in Fig. 10.<sup>10,11</sup>

The burst gate is the first tube and the step down transformer in its plate reduces the source impedance to a value that will efficiently drive the crystal. The second tube is an amplifier which brings the signal to sufficient amplitude for driving the limiter, which is the third tube. The crystal is used in its series mode. The total resistance in the crystal circuit determines the  $Q$ . A bridge circuit is used to neutralize the shunt capacity of the crystal to make the device a good filter particularly at frequencies away from resonance. The limiter is of the cathode coupled type, which provides clipping against grid cutoff as well as grid current limiting.

<sup>10</sup> W. E. Good, "Color synchronization in the NTSC color television receiver by means of the crystal filter," 1953 IRE CONVENTION RECORD, Part 4, "Broadcasting and Television," pp. 9-12.

<sup>11</sup> W. J. Gruen, "Theory of afc synchronization," PROC. IRE, vol. 41, pp. 1043-1048, August, 1953.

This value of  $Q$  (28,000) found above for a 200 cps noise bandwidth, will result in a static phase error of  $5^\circ$  with a burst frequency to filter frequency detuning of approximately  $\pm 5.5$  cps. The FCC specifications allow a transmitter subcarrier tolerance of  $\pm 10$  cps. Therefore, in order to accommodate the transmitter subcarrier tolerance, as well as the crystal tolerance and temperature drift, it is necessary to compromise the  $Q$  and/or the static phase error. In current practice, little use is made of the passive ringing circuit.

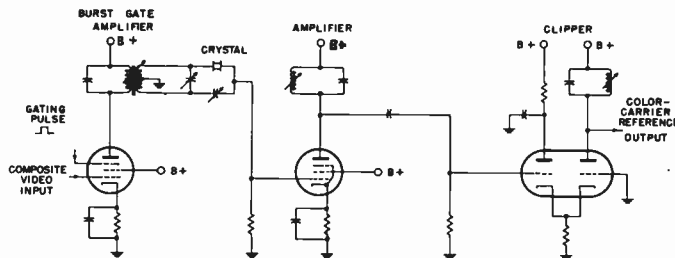

Fig. 10—Crystal ringing circuit.

2) *Automatic Phase and Frequency Control:* Automatic phase and frequency controlled oscillator circuits have been more commonly used to provide the locally generated subcarrier signal. Figs. 2 and 4 include an arrangement of a typical APFC loop. The relative phases of the burst signal and locally generated subcarrier signal are compared in the phase detector and the output control voltage is then fed to the reactance tube through a low pass double time constant filter. The reactance tube then corrects the phase of the oscillator.<sup>11</sup>

When the burst and local reference signals are not in synchronism, the phase difference between them assumes all possible values and the output is a beatnote at the difference frequency. The feedback loop distorts this beatnote due to the action of the reactance tube increasing and decreasing the rate of phase change for successive half cycles. It is the net dc component of this distorted wave which provides the correcting voltage to pull the system into synchronism.

For the most efficient pull-in performance, the lock-in range may be expressed as<sup>12</sup>

$$\Delta f_i < \frac{1}{2} \sqrt{T_f} (B_{NN})^{3/2}$$

where  $T_f$  is the stabilization time in seconds and  $B_{NN}$  is the noise bandwidth of the APFC loop ( $= \frac{1}{2} B_N$ ).

Choosing a noise bandwidth  $B_N = 200$  cps and substituting in this equation, we find that for a 1 second stabilization time, the maximum frequency difference allowable is 500 cps. This represents a high degree of stability for LC oscillators and has led to the use of crystal oscillators.

An APFC circuit is shown in Fig. 11. The first tube

<sup>12</sup> D. Richman, "The dc quadricorrelator: a two-mode synchronization system," PROC. IRE, vol. 42, pp. 288-299; January, 1954.

is a gated amplifier used to time separate the color burst from the composite signal. The phase splitting transformer in the plate provides two phases of burst  $180^\circ$  apart for the phase detector. The phase detector consists of two peak detecting diodes with their plate and cathode voltages in quadrature.<sup>11</sup> Burst is the voltage on one element and color-carrier reference on the other. The output of the phase detector consists of the sum of the two rectified outputs. This output voltage is fed through the filter to the reactance tube. The reactance tube is of the capacitive type. The inductance in the grid circuit is used to improve the  $Q$  of the variable capacitor presented by the reactance tube. The oscillator is a modified Pierce crystal oscillator with electron coupling to the plate. The reactance-tube oscillator sensitivity,  $\beta$ , is in the order of 100 cps/volt. The phase detector sensitivity,  $\mu$ , is approximately 0.2 volt/degree of phase error. The maximum dc loop gain,  $f_c$ , is 20 cps/degree of phase error. The pull-in range is  $\pm 150$  cps and noise bandwidth is 250 cps.

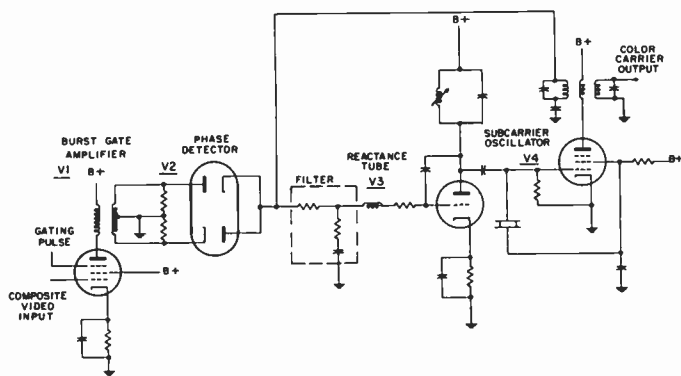

Fig. 11—Typical APFC circuit.

3) *Dual Mode*: As was noted before, the high oscillator stability requirements for good noise bandwidth and a 1 second stabilization time appear difficult to achieve with LC oscillators. However, small noise bandwidths are necessary only when the system is in synchronism. Inspection of the above equation indicates that if the noise bandwidth is increased when the system is out of lock, the maximum pull-in frequency, for a constant stabilization time, is increased. Therefore, the oscillator stability becomes less important and LC oscillators may be considered. There are two ways to increase the noise bandwidth: increasing the ac/dc gain ratio  $m$  or increasing the dc loop gain  $f_c$ .<sup>12</sup> To date, dual mode systems have not found extensive use in receivers.

*Color Killer*: Monochrome television signals will apparently be transmitted for some time to come and color television receivers will be required to operate well on this type of signal. No signal information through the chrominance channel should reach the display device during this type of transmission. Automatic means for doing this are generally considered highly desirable. Since the color synchronizing signal distinguishes color

transmission from monochrome, the responsibility for providing a switching signal can be placed on the color synchronizing circuit.

The ringing circuits discussed previously will not produce a local reference signal for the demodulators in the absence of color burst. If the demodulators are not amplitude sensitive to the chrominance signal in the absence of local reference signal, no further color killing action is necessary. If the demodulators are amplitude sensitive, then the grid bias developed by the limiters may be used as a source of automatic switching signal to bias the chrominance amplifier off during monochrome transmission.

In the case of APFC controlled oscillators, local reference signal is applied to the demodulators, whether there is color burst present or not and biasing off the chrominance channel is mandatory. For the single mode APFC loop, the bias developed from one of the phase detector diodes is used as the automatic switching signal. This is an envelope detector and it will produce an average output which is a function of the thermal noise level as well as of the desired burst signal. Therefore, switching level in the presence of thermal noise may become ambiguous.<sup>12</sup> As opposed to the envelope detector, the average output from a synchronous demodulator depends only on the signal. Thermal noise causes fluctuations about the average but does not contribute to it. Thus a linear balanced synchronous detector is unaffected by signal to noise ratio and the quadrature detector in the dual mode APFC system is a much more reliable source of switching voltage for "color killer" operation.<sup>12</sup>

### C. Color Processing Circuits for Simultaneous Displays

*Introduction*: The similarity between monochrome and color television receivers generally ends at the circuits which follow the IF amplifier. In the monochrome receiver, one detector is used to recover the video signal modulation and the 4.5 mc sound beatnote. The video signal is amplified for delivery to the picture tube, while the sound is removed and amplified separately. In a color receiver, on the other hand, the composite color signal is separated into luminance and chrominance components. The chrominance signal is processed to yield three color difference signals. The luminance signal is amplified and combined with the color difference signals to result in the red, green, and blue primary signals. The IF sound carrier and the 4.5 mc sound beatnote are handled much the same as in a monochrome receiver except that they must not intermodulate with color subcarrier sidebands as noted in Section 2A.

Fig. 12 shows the two basic methods of processing the composite color signal for a three gun color display. In Fig. 12(a), the composite color signal  $E_M'$  is filtered and amplified by the luminance circuits for application to the three gun display. The bandwidth of the luminance or monochrome signal  $E_Y'$  is restricted to approximately 3.2 mc to eliminate most of the carrier-chro-

minance energy. The bandpass amplifier selects that band of frequencies containing the sideband chrominance information generated by the balanced modulators at the transmitter, namely,  $E_C'$ . This bandpass encompasses those frequencies 0.6 mc above and 1.5 mc below the chrominance subcarrier. The color difference signals  $E_R' - E_Y'$ , etc., are derived by synchronous detection of the carrier-chrominance signal, filtering the products, and matrixing. The reference carrier required for synchronous detection is generated by the 3.58 mc oscillator which is automatically frequency and phase controlled by color sync information extracted for the composite signal  $E_M'$ . The color difference signals are added to the luminance signal to produce  $E_R'$ ,  $E_G'$  and  $E_B'$  as the grid-cathode voltage of the red, green, and blue guns of the color reproducer.

reverse arrangement is also practiced. These methods provide additional flexibility over that shown in Fig. 13 since the effect of reflections from the luminance delay line on the chrominance response can be minimized. Similarly, broad band trapping due to the bandpass amplifier input stage can also generally be avoided.

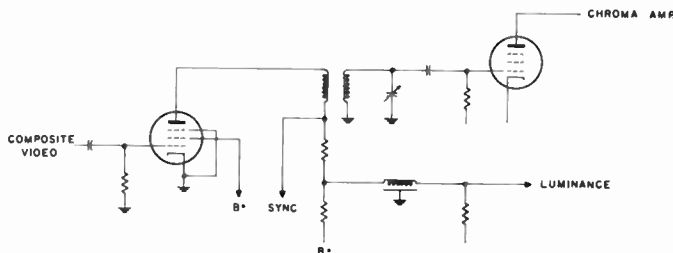

Fig. 13—Chrominance take-off circuit.

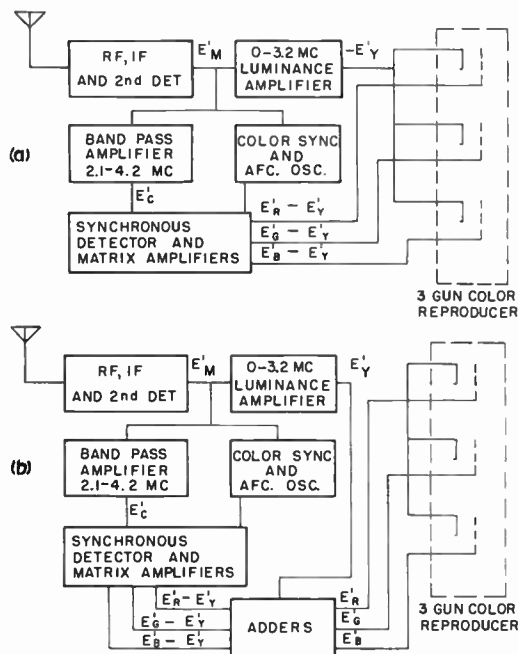

Fig. 12—Basic color processing methods.

In Fig. 12(b) the signals  $E_R'$ ,  $E_G'$ , and  $E_B'$  are formed by a decoder before application to the color reproducer. Such a decoder includes the circuits of Fig. 12(a) plus a trio of adder amplifier stages in which the luminance and color difference signals are separately added.

**Chrominance Separation Circuits:** For receiver designs where the luminance and chrominance signals are taken from separate diodes (Fig. 2), there is no further problem of chrominance separation. In single detector receivers however, several configurations of chrominance separation circuits are found. In one, the chrominance signal is coupled to the chrominance bandpass amplifier from the input to the luminance delay line. Fig. 13 is a typical example of this practice. An alternative arrangement, shown in Fig. 7 involves the use of a pentode stage with the luminance signal taken from the cathode circuit, and the chrominance signal from the plate. The

**Chrominance Amplifier:** Chrominance amplifiers, or bandpass amplifiers, select and amplify those frequencies containing the chrominance information. The principal functions of this amplifier are: to equalize, if necessary, the equivalent video response of the chrominance channel to the demodulator inputs; to separate the 4.5 mc sound carrier and chrominance signals so that they do not mix during the demodulation process; and to provide for "color kill" action, or automatic disabling of the chrominance amplifier when monochrome programs are being received, and for automatic chrominance gain control action, where desired.

One classification of color processing circuit is the bandwidth of the two chrominance video channels after demodulation. Receivers can be designed with equal bandwidths in the two demodulator channels, or with one wide band and one narrow band channel. The latter arrangement has been thought to make maximum use of the transmitted color signal. The former appears to be more economical at present with perhaps small, if any, sacrifice in performance. While the details of these two classifications will be treated later, the equi-band design generally involves chrominance bandwidths of the order of 600-700 kc, and the wide band channel is as much as 1.5 mc in a differential bandwidth receiver. The available bandwidth above the subcarrier frequency is limited by the sound trap requirements in the IF amplifier. In general, only 600-700 kc at most above the subcarrier frequency can be had at the IF detector. The limitation of bandwidth below 3.58 mc is produced in the chrominance amplifier. The response of the bandpass circuits, then, is determined in part by the type of signal processing to be used in the demodulators.

Approximately 30 db additional sound attenuation relative to chrominance may be required in the chrominance amplifier to prevent generation of 920 kc difference frequency beat at the demodulators. This is the difference frequency between the 4.5 mc sound carrier and the 3.58 mc chrominance subcarrier. To achieve this

attenuation a trap is normally located in the chrominance channel to reduce the level of 4.5 mc sound beatnote. This trap may serve as the sound carrier takeoff to the conventional fm detector and audio system.

When a color receiver is tuned to a monochrome program, luminance signal components as well as noise in the neighborhood of the subcarrier can pass through the chrominance channel, be demodulated, and appear as low frequency color on the picture tube. This is termed "cross color," and is undesirable. Many receivers, therefore, incorporate automatic means for switching off the chrominance channel in the absence of a color signal. The presence of the burst in the color sync channel is used to determine whether color or monochrome is being transmitted. A voltage is developed which can be used to switch a chrominance bandpass amplifier on as in the circuit of Fig. 14. The burst generates a negative bias at the plate of the apc phase detector which cuts off the color killer tube and allows the chrominance amplifier to function.

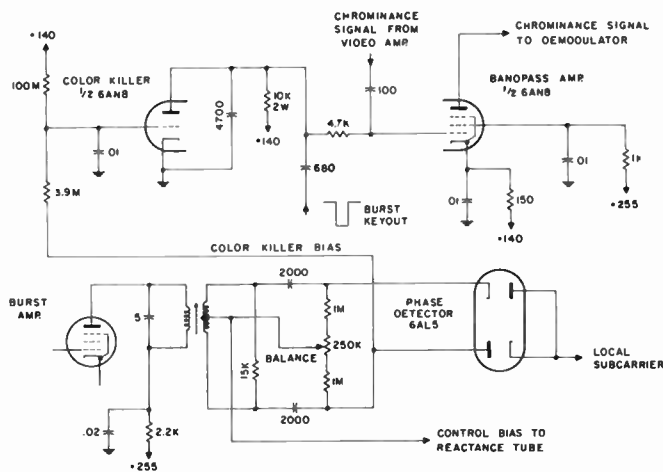

Fig. 14—Color killer circuit.

A second color killer arrangement is shown in Fig. 15. In this circuit the burst is amplified along with the chrominance signal. If the amplifier were cut off with a dc bias during monochrome transmissions, it would be insensitive to the color sync burst when a color transmission began. A positive pulse is therefore applied to the grid of the bandpass amplifier. The pulse, which is timed so that the tube is conductive during the burst period, typically has an amplitude of approximately 30 volts. Since the top of the pulse is restored to zero bias at the grid, a negative bias is maintained on the grid during the remainder of the time. In this manner, the stage can be cut off during a portion of the time, and operated at maximum during the burst interval. These features can all be found on the schematic of Fig. 15. The color control selects an amount of positive pulse to be applied to the bandpass amplifier to adjust the gain of this stage when the larger color killer pulse is not present. The dc bias fed at the same time from the tapped down output of the phase detector tends to maintain constant burst level in the system. This provides automatic color

gain control (ACC). Finally, if the color killer tube is allowed to conduct, the pulse fed to the bandpass amplifier grid is sufficient to disable the remote cutoff pentode as described above.

When sound carrier signal is taken from the chrominance amplifier the color killer action must obviously be applied beyond the point of sound carrier separation.

**Burst Channel Take Off:** The color synchronizing burst can be separated and fed to the subcarrier regenerator channel in any of several fashions. Since the burst requires amplification in the same frequency range as the chrominance signal, it is usual to separate the burst after amplification in the color channel. Such an arrangement is shown in the block diagrams of Figs. 2 and 4. The burst gating circuits are of the type described in the section on Color Synchronization.

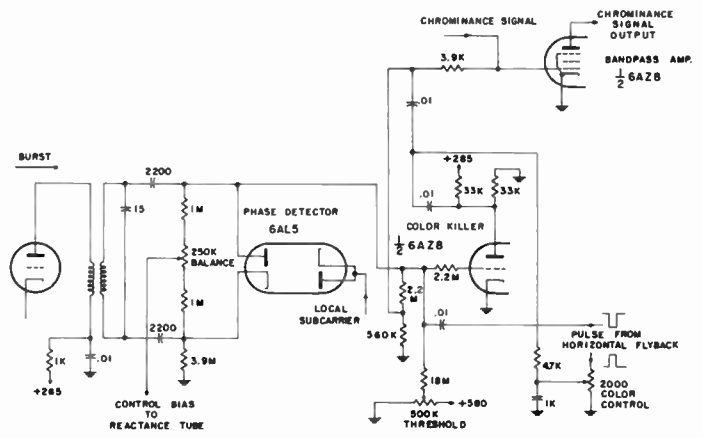

Fig. 15—Color killer circuit with automatic color gain control.

**Contrast Control:** The contrast control in early color receivers controlled the chrominance gain as well as the monochrome or luminance gain. A separate color saturation control ("color" gain) was used to correct the differential between the chrominance and luminance signals. Contrast adjustment by this means did not upset the luminance to chrominance balance, making for ease of operation. In such receivers, the luminance and chrominance contrast controls were often located in different circuits, but the two control elements were in tandem on a single control shaft. However since the differential control was desired as an operator control, later designs provide separate luminance and chrominance gain controls. Separate controls provide flexibility of circuit design, economies, and greater range for adjustment to signal and program requirements.

**Synchronous Detector Circuits:** In color receivers, synchronous detectors are used to convert the chrominance subcarrier signal back to color difference signals. Since the chrominance portions of the signal consist of the sidebands of two carriers in quadrature, the usual three gun type of receiver generally recovers the color difference signals by using a synchronous detector for each carrier. A synchronous detector or demodulator is analogous to converter operation in monochrome receivers, the difference being that the reference and chroma input



signals to the demodulator tube are of the same frequency, hence, the term "synchronous" detector.<sup>13</sup>

Several types of synchronous detectors are now being used for three gun display color receivers. They fall into two categories: low-level type which requires amplification after the demodulation, and high-level type with the output signal coupled directly to the cathode-ray tube. Diodes, triodes, and pentodes<sup>14-16</sup> have all been used for the demodulation function with the recent trend largely to triodes. The two input signals are applied so that the resultant plate current is the result of

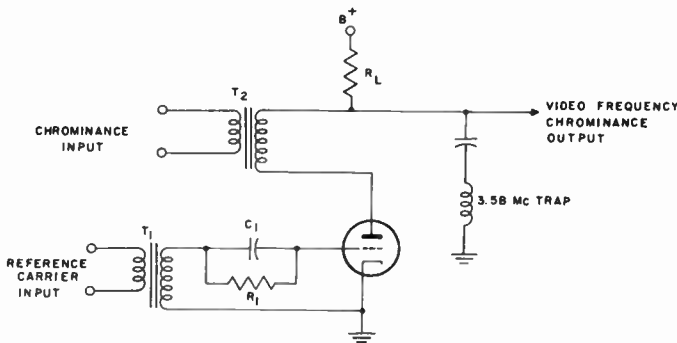

Fig. 16—Typical triode demodulator.

the product of the input signals. A typical basic triode high level demodulator circuit is shown in Fig. 16.

**Matrixing:** Matrixing, as it applies to color television receivers, is best understood by reviewing the matrix function in the transmitter. The transmitter matrix proportions the three gamma corrected color signals  $E_R'$ ,  $E_G'$  and  $E_B'$  into positive and negative signals. When

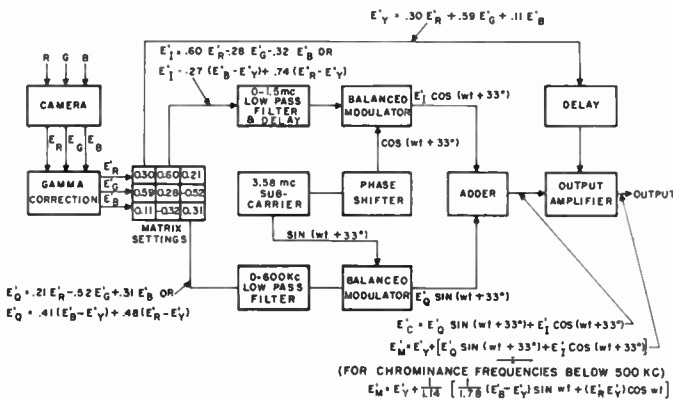

Fig. 17—Color transmitter encoding system.

these signals are added together in accordance with the matrix formula<sup>17</sup> (see Fig. 17) three new signals are formed, namely,  $E_Y'$ ,  $E_I'$  and  $E_Q'$ . The quantities of

<sup>13</sup> D. C. Livingston, "Theory of synchronous demodulators as used in the ntscc color television receiver," Proc. IRE, vol. 42, pp. 284-287, Jan. 1954.

<sup>14</sup> R. Adler and C. Heuer, "Color decoder deflection tube simplifies color decoders," Electronics, vol. 27, pp. 148-151; May, 1954.

<sup>15</sup> D. H. Pritchard and R. N. Rhodes, "Color television signal receiver demodulators," RCA Rev., vol. 14, pp. 205-226; June, 1953.

<sup>16</sup> Kurt Schlesinger, "Television color detectors use pulsed-envelope method," Electronics, vol. 27, pp. 142-145; March, 1954.

<sup>17</sup> G. K. Brown, "Mathematic formulations of the NTSC color television signal," Proc. IRE, vol. 42, p. 67; January, 1954.

$E_R'$ ,  $E_G'$  and  $E_B'$  used to form the luminance signal  $E_Y'$  are proportioned with respect to the spectral sensitivity of the eye.<sup>18</sup> This signal is transmitted full bandwidth and can produce excellent black and white pictures on monochrome receivers. The positive and negative values of  $E_R'$ ,  $E_G'$  and  $E_B'$ , used to form  $E_I'$  and  $E_Q'$  are proportioned to make the most efficient use of the transmitter modulation aperture when these  $E_I'$  and  $E_Q'$  signals are converted into two quadrature chrominance carrier components which are combined with the luminance component  $E_Y'$ .

The matrix in the receiver performs a reciprocal function to that of the matrix at the transmitter. In Fig. 18 the receiver demodulators convert the two quadrature chrominance carrier components back to "I" and "Q" signals which are coupled into the matrix to form color difference and finally color drive signals.

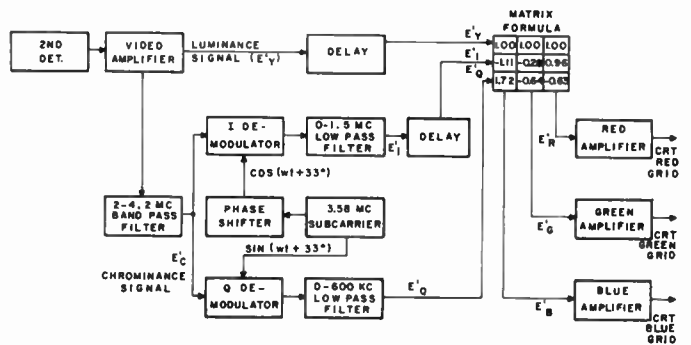

Fig. 18—Color receiver, I-Q decoding system.

A simpler form of receiver matrix is realized when the axes chosen for synchronous detection recover two of the color difference signals directly, such as  $E_R' - E_Y'$  and  $E_B' - E_Y'$ . Third color difference signal,  $E_G' - E_Y'$ , can be recovered by a simple matrix which adds quantities of the first two signals proportional to the formula:

$$E_G' - E_Y' = (-.51E_R' - E_Y') + (-.19E_B' - E_Y')$$

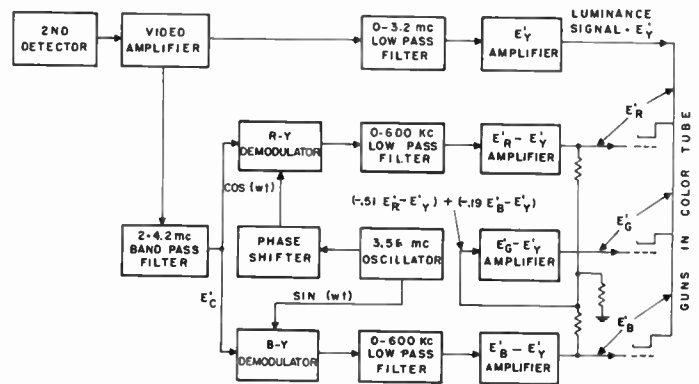

Fig. 19—Color receiver, (R-Y)-(B-Y) decoding system.

In the block diagram (Fig. 19), positive quantities are added in the proper ratios. The sign is changed since this signal is inverted in the  $(E_G' - E_Y')$  amplifier. The

<sup>18</sup> W. F. Bailey, "The constant luminance principle in NTSC color television," Proc. IRE, vol. 42, p. 60; January, 1954.

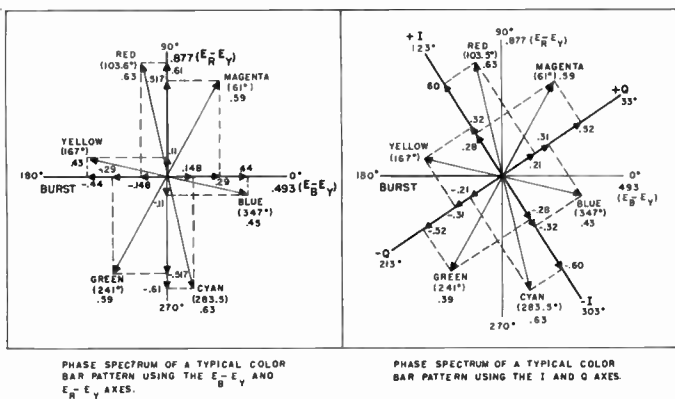

Fig. 20—Chrominance signal phase spectrum.

outputs of the synchronous detectors (as shown in Figs. 18 and 19), are coupled into adder circuits. These matrix or adder circuits can vary widely in design. Typical versions will be described.

A classification of color processing circuits involves the bandwidths of the color channels after demodulation. As the color television signal is transmitted, the chrominance signal contains two components which, when detected along the so-called *I* and *Q* axes are found to have bandwidths of 1.3 and 0.6 mc respectively. A receiver designed to demodulate along these axes with the appropriate bandwidths would appear to make maximum use of the transmitted signal. The demodulator and matrix circuit of Fig. 21 is an example

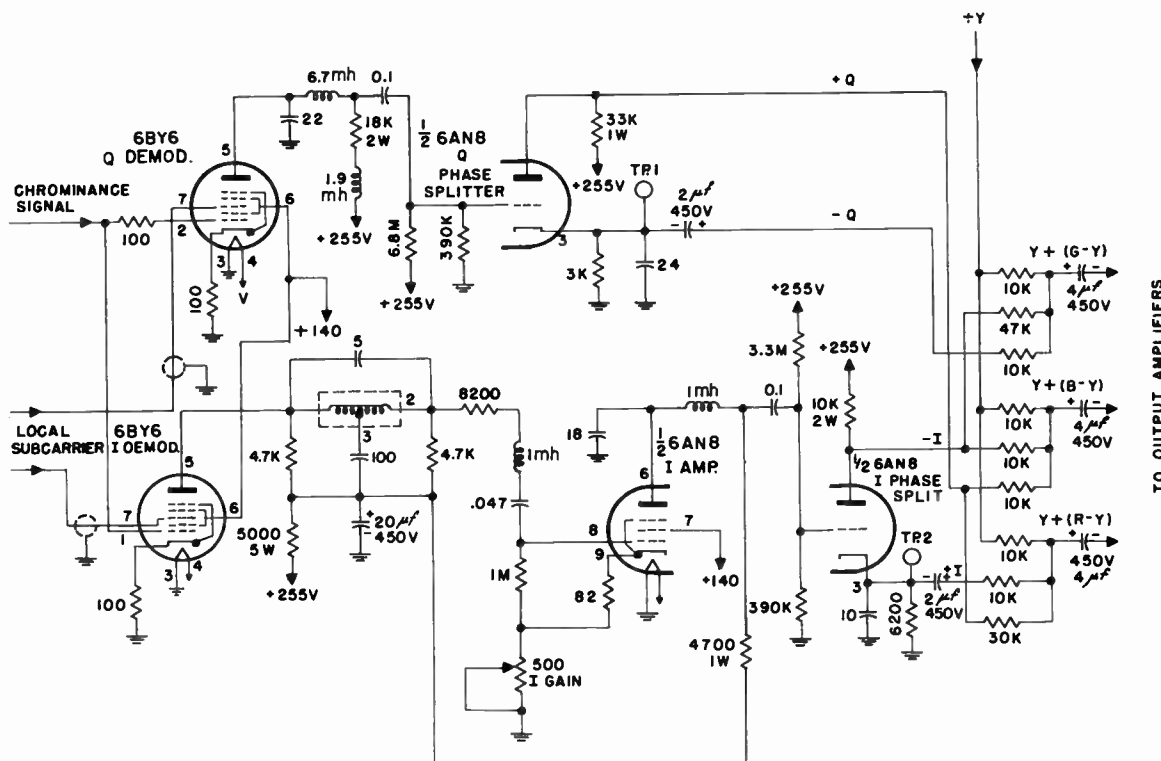

Fig. 21—*I*-*Q* demodulator—matrix amplifier.

simultaneous signal  $E_{R'}$ ,  $E_{G'}$ , and  $E_{B'}$  are formed by coupling the color difference signals to the grids and the luminance signals to the cathodes of the guns in the color crt. Consequently, the two forms of signals are added (matrixed) by each gun.

When the synchronous detector output filters are limited to a 600 kc passband, any chrominance axis can be selected for detection without crosstalk effects. A matrix can be tailored to add the synchronous detector outputs in the proper proportions to recover the desired chrominance information.

The phase spectrum of the chrominance signal for a typical color bar pattern is shown in Fig. 20, illustrating how the two systems for matrixing color signals ( $R - Y$ ,  $B - Y$ ) and *I*, *Q*—produce identical color signals for chrominance signals below 500 kc. In the receiver, the

of such practice. The 6BY6 pentagrid demodulators operate along the *I* and *Q* axes. Since the *I* axis circuits have wider bandwidth than the *Q*, additional delay must be inserted in the *I* channel to provide time coincidence of output transients in the two channels. This delay element commonly takes the form of a bridged *T* filter section which in addition tends to equalize the *I* channel phase response. The nominal delay required at this point is approximately 0.5  $\mu$ s. Both plus and minus values of *I* and *Q* are needed to produce the three color difference signals, so that phase splitters are used in both channels. The color difference and luminance values are all added together at low level. The resultant red, green, and blue primary signals are amplified and delivered to the picture tube.

Such a circuit arrangement, which may almost be

considered the classical approach to color signal decoding, appears to be losing favor. At present considerable economy can be practiced by compromising the bandwidth considerations and demodulating along the  $R-Y$  and  $B-Y$  axes with equal bandwidths of the order of 600 kc. With present techniques, the actual degradation in picture quality when this compromise is made is open to question. One such approach is shown in the schematic of Fig. 22. Type 6AL5 double diodes connected as balanced synchronous demodulators are employed. The bandwidth of the chrominance signal is limited in the bandpass amplifier. Filters following the demodulator further limit the bandwidth of the video components. The  $R-Y$  and  $B-Y$  video signals are amplified for delivery to the picture tube grids. In addition, samples of the  $R-Y$  and  $B-Y$  signals are added and inverted to form the  $G-Y$  signal. The luminance ( $Y$ ) signal is

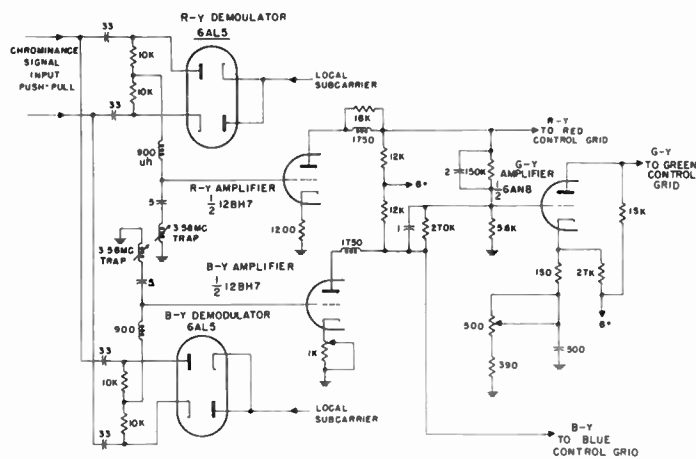

Fig. 22—Equiband demodulator—matrix amplifier I.

delivered to the three cathodes of the picture tube in parallel. The cathodes are used for the wide band luminance signal and the grids for the narrow band video chrominance signals in this arrangement where the final addition is in the picture tube. This is preferred to the reverse arrangement which would involve a narrowband filter in the cathode of the picture tube and thus produce selective degeneration in the luminance passband.

Another arrangement of the equiband technique is shown in Fig. 23. Here, the chrominance subcarrier signal is demodulated at a sufficiently high level that the color difference signals can be applied directly to the picture tube grids. The demodulators operate along the  $R-Y$  and  $G-Y$  axes. The outputs are sampled, added, and inverted to produce the  $B-Y$  color difference signal.

The  $B-Y$  color difference signal requires the greatest total swing (from peak white to peak saturated blue) of the three color difference signals. Operating the demodulators and matrix in this fashion makes the task of providing adequate dynamic range for the color difference signals somewhat simpler than with  $R-Y$  and  $B-Y$  quadrature decoding.

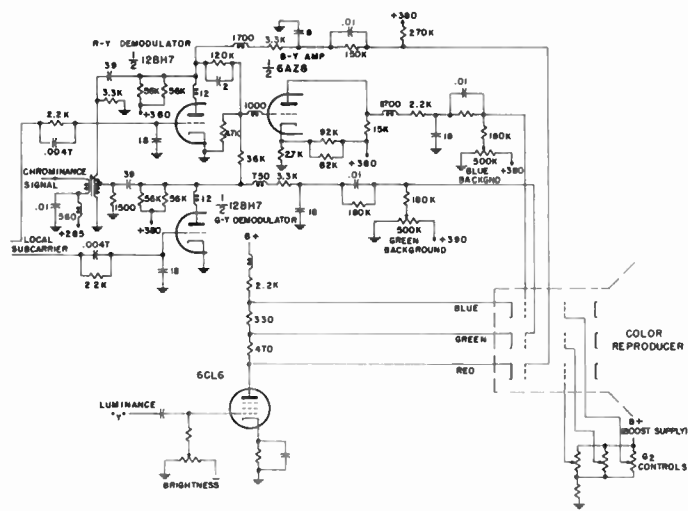

Fig. 23—Equiband demodulator—matrix amplifier II.

*Video Amplifiers and DC Components:* The difference in efficiencies of the red, blue, and green phosphors in the color picture tube is a factor in determining the relative video drive requirements to the three guns. The red phosphor used in color reproducers available thus far requires approximately twice the beam current of the green and blue phosphors to produce white (see Fig. 25). If the screen grids are adjusted for equal average transconductance (control grid cutoff) on each of the three guns, then the video drive for the red gun must be approximately twice that for blue and green to produce white. This unequal drive technique is generally adopted by receivers that couple  $R$ ,  $B$ , and  $G$  signals to the cathode ray tube. Receivers that couple the monochrome signal and the color difference signals to the color picture tube separately usually employ more nearly equal drives for simplicity. In such cases, the full monochrome voltage is coupled to the red cathode while the green and blue voltages are divided by a fixed ratio by a frequency compensated network. The color difference signals are proportioned for proper matrixing with the monochrome signals in the cathode ray tube. In this arrangement, the control grids and screen grids of the picture tube are adjusted to meet the static and dynamic white balance requirements. A typical video amplifier to crt coupling circuit arrangement is included in Fig. 23. The white balance requirements are discussed in Section IV F below.

A disadvantage of equal drive operation is that the peak luminance for the red gun is limited due to the low screen potential and reduced control grid aperture used to derive a relatively higher red gun transconductance.

Accurate dc reference of the video signal blanking level at each gun of the color display is desirable for good colorimetric reproduction. Differential changes in backgrounds due to alterations in the composition of the video signal must be avoided. The circuits controlling the setup of the cathode ray tube should be designed to minimize changes in dc among the three guns which will

upset white balance. Conventional dc restorer circuits, can be used to fix the blanking or black level for each color when *R*, *B*, and *G* signals are ac coupled to the cathode ray tube. In receivers where the luminance and color difference signals are ac coupled to the color picture tube independently, restoration of the combined signals is required since each contains a dc component. This type of operation is typical in circuits where the restoration is affected between the grid and cathodes of the picture tube.

Black level stabilization or control (*i.e.*, dc restoration) in color receivers is more demanding on the high voltage power supply than in monochrome receivers. This results from the combination of the total power required to maintain adequate brightness on large area peak white scenes and from a high voltage regulation requirement. Accordingly, recent receivers have used dc coupled color difference channels to retain adequate colorimetry with an ac coupled luminance channel to relieve the peak high voltage power requirements.

In Fig. 23, the outputs of the color difference channels are dc coupled to the picture tube grids. The luminance amplifier is ac coupled from the second detector but its output is dc coupled to the three cathodes of the color picture tube and the master background control is a grid bias control in the amplifier. The operational control for varying the background of a color reproducer should not affect the gray scale. When the system is set up for equal luminance drive operation, this should not present a problem since equal changes in bias to the three guns produce equal changes in brilliance from the three phosphors if the transfer characteristics of the guns are similar. Consequently, the gray scale tracking is maintained when the master background produces equal changes in bias to the three guns.

*Summary:* A representative number of circuits presently employed in color television receivers has been presented. With slight modification the details discussed probably apply to all receivers available on the market at the current time. It should not be inferred, however, that today's simplest or most economical circuit will still be in use a few years hence. Other forms of decoding or other chrominance bandwidths may find favor and result in even more economical designs and improved performance.

#### IV. CIRCUIT FUNCTIONS AND COMPONENTS PECULIAR TO THE COLOR PICTURE TUBE

##### A. The Shadow Mask Tube

In recent years the tri-color picture tube,<sup>19</sup> of the shadow mask type, has made the transition from a planar mask and screen to a domed, self-supporting, aperture mask kinematically aligned to a spherical

face-panel.<sup>20</sup> On the face-panel the phosphor screen is deposited in tri-color dot groups. As in the planar mask type, a three beam electron gun structure scanned by a single deflection yoke produces a simultaneous display in the three additive primary colors. The shadow mask picture tube type now available is the RETMA type 21AXP22. This color tube is of the round metal cone 21-inch diameter size. In many respects it resembles a round television monochrome tube. Bulb shape, spherical direct view screen, over-all length, and weight are similar. Electrical functions follow the basic operations of the monochrome tubes. Electron beams are generated in similar gun structures, deflected by the same circuits, and excite a direct view phosphor coated screen.

The differences from monochrome picture tubes arise from the nature of the color discriminating functions. The screen is composed of a multitude of three color phosphor areas. These are selectively energized through the adjacent shadow mask apertures by parallax-alignment to three triangularly-grouped electron beams originating in the tube neck. The three spaced beams make necessary a relatively large neck diameter for the tube, and an enlarged deflection yoke. Since equal action on the spaced beams is not an inherent property of the deflecting field, corrective action is furnished by a convergence assembly which improves registry of the three independent images. Manufacturing variations in the color tubes together with magnetic fields encountered in their use make it impossible to guarantee precise alignment of the electron beams. Therefore various magnetic devices are used on the tube for corrective trimming. Among these are beam positioning magnets, blue corrector magnet, and color purity magnet. The three electron guns extend the video signal circuitry which must be of high quality. In its color discriminating function, the shadow mask absorbs approximately 85 per cent of the total incident beam current. To provide the color phosphor screen with an excitation and brightness approaching normal monochrome tube operation, the anode power supply is considerably larger in voltage and in current capacity.

In the operating tri-color, shadow mask tube the desired end results are three superimposed rasters set up to the reference white color which may then be luminance signal driven to high brightness levels with no visible color change. This duplicates the monochrome picture tube which is the comparison standard in performance. The insertion of the color difference signals on the appropriate guns provides the color images in contrast to white.

##### B. Requirements of the Deflection Yoke and Circuits

The modern deflecting yoke for the shadow mask tube is the result of many years of development as the performance of this component is vital to the attainment

<sup>19</sup> H. B. Law, "A three-gun shadow mask color kinescope," *PROC. IRE*, vol. 39, pp. 1186-1194; October, 1951. Also, Moody, H. C., and VanOrmer, D. D., "Three-beam guns for color kinescopes," *PROC. IRE*, vol. 39, pp. 1236-1240; October, 1951.

<sup>20</sup> N. F. Fyler, W. E. Rowe, and C. W. Cain, "The CBS-colortron: a color picture tube of advanced design," *PROC. IRE*, vol. 42, pp. 326-334; January, 1954.

of congruence of the three color image.<sup>21</sup> This is regarded of such importance that associated imperfections, such as pattern distortion, are often disregarded. Fortunately, raster shapes of the pin-cushion kind are less obvious in shadow mask tubes today; the spherically curved screens complement the deflection yoke performance.

Beam to beam spacing in the shadow mask tube is many times the effective beam diameters. The area circumscribing the triangularly grouped beams is thus a significant proportion of the internal deflection yoke area. Picture tubes with only one operating beam contain noticeable beam spot distortions when operated with the average deflection yoke. By analogy the three spaced beams of the tri-color, shadow mask tube may be considered as the filaments of a single large beam. Therefore some color deflection yoke distortions are apparent by the failure of the beams to converge at the screen when scanned throughout the entire screen area. A monochrome picture, which is a triple color mixture, thus degenerates into separate misregistered primary colored images. To obtain convergence, yoke winding distributions are compromised to try to obtain a total instantaneous deflection for each beam relative to the other beams in a proportion required by the screen area being scanned. This is an extension of monochrome yoke properties requiring controlled winding distributions. Other deflection yoke factors, such as capacitive unbalance and cross-coupling between windings need careful attention.<sup>22</sup> Beam to beam spacing in the yoke region of the shadow mask tube is fixed by considerations of color selection. This being established, the uniformity of the deflecting fields has been extended by enlarging the yoke inside diameter to 2.75 inches. Further extension in this direction would be made at the expense of yoke scanning power requirements.

The location of the deflection yoke on the neck of the color tube is critical with respect to the color screen and electron beams. Adjustments are provided for lateral and radial shifting to satisfy yoke position requirements.

Color yoke circuitry is similar to monochrome television practice except for increased power demands. Because the electron beam entry into the yoke field is color purity critical, the correction of raster miscentering is accomplished by applying direct currents to each yoke winding. Capacitive balancing of the horizontal yoke windings requires careful attention to remove scan line "ringing" as it differs between electron beams.

### C. Color Purity

It is a fundamental requirement that a tri-color tube display each red, green, and blue primary color dis-

tinctly. The shadow mask tube type does so by selecting only those portions of each incident electron beam that is directed to its respective color dot on the color screen. When, through errors in operation of the picture tube or the electron optical components, the electron beam strikes portions of the adjacent color dots, a primary is said to be contaminated. This usually occurs towards the outer screen boundaries, and the tube is described as lacking color purity.

The color selectivity of the shadow mask tube is best explained by the concept of "color centers."<sup>23</sup> Physically, these are the locations of the light sources relative to the screen during the optical exposures which were made in processing the tri-color phosphor screen. Thus, the screen dots of each color are masked from view except from the area of their respective color centers.

The triangularly grouped electron guns are intended to aim their beams precisely through their respective color centers. However, assembly tolerances are involved and these are accommodated within limits by a purity magnet. This device provides an adjustable lateral magnetic field across the neck of the color tube behind the deflecting yoke. By rotating and adjusting the strength of the purity magnet the three beams are deflected into the color centers. Furthermore, the axial position of the deflection yoke that aligns the virtual deflection plane to the three color centers must be found. The yoke has a unique position on the tube neck generally described as the location in which the yoke center of deflection lies in the plane of the color centers. In practice the yoke color center shifts axially with variations in scanning currents in a characteristic manner which is compensated by correction lenses used during screen exposures in CRT manufacture. These related adjustments are optimized by attaining uniform color throughout the screen area. By observing the color dot screen through a low power microscope the electron illuminated portions of the color dots may be checked for misregistry in any part of the screen.

Usually the overall color purity of the display in one or all colors is quite satisfactory with these steps except for local edge areas. External purity correcting devices have been developed to compensate for this condition. These take the form of adjustable magnet assemblies fitted around the color tube body which apply small, but significant, corrective effects on the incident electron beam angles.

It is obviously true that a reduction in beam cross-section within the finite color centers permits more latitude in the radial excursions brought about by the deflection and convergence yokes. Any means effective in reducing the beam diameters on the color centers, while retaining beam focussing on the phosphor screen, also increases the beam size at the screen. Such design practice is followed for another reason, moiré. This is a

<sup>21</sup> A. W. Friend, "Deflection and convergence in color kinescopes," *Proc. IRE*, vol. 39, pp. 1249-1263; October, 1951.

<sup>22</sup> C. E. Torsch, "High efficiency low copper sweep yokes with balanced transient response," *TRANS. IRE, PGBTR-6*, pp. 17-32; April, 1954. Also, C. E. Torsch, "Extension of the balanced transient response principle to color television yokes," *TRANS. IRE, PGBTR-6*, pp. 33-35; April, 1954.

<sup>23</sup> D. D. VanOrmer and D. C. Ballard, "Effects of screen tolerances on operating characteristics of aperture mask tri-color kinescopes," *Proc. IRE*, vol. 39, pp. 1245-1249; October, 1951.

visible beat phenomenon of the scanning lines on the spaced apertures in the shadow mask. Where the scanning line width is large enough to overlap adjacent apertures, the moiré is greatly reduced.<sup>24</sup>

#### D. Magnetic Shielding

The shadow mask tube is color purity sensitive to deviations from straight line electron beam trajectories. Actual color selection is provided by beams differing by about two degrees. A fraction of this is sufficient to degrade color purity. Any magnetic field along the beam paths will cause a path curvature that in effect displaces the color centers. Electric fields are essentially removed by tube construction practices but magnetic fields readily permeate the bulb interior. The effects of these fields may be neutralized by compensating fields. In this area there is no standard arrangement but all approaches seem to fit the pattern of providing either permanent magnet or electro-magnetic elements around the faceplate and the funnel throat (or both) such that by adjustment the horizontal component of the earth field may be neutralized along the beam trajectories. At present no receiver adjustments are made for the possible strength variations of the vertical component of the earth's field. For each receiver location and orientation, however, the effective earth field horizontal component is neutralized by receiver adjustments.

#### E. Dynamic Convergence

Capable of displaying three simultaneous images in the primary colors, the shadow mask tube suffers the faults common to any system requiring the registry of the three images into a composite picture. Each primary color image should be alike in size, shape and position. On the shadow mask tube, the images are nearly alike in size as they are generated by a common deflection yoke. However, the shape and position of each image are enough different, due to the probable lack of initial electron beam alignments and the inherent deflection displacements of the electron beams, that corrective means are necessary which establish the desired condition that the electron beams converge at all positions on the picture screen area.

A convergence adjustment performed on the electron beams by permanent magnets or dc electrical quantities is known as static convergence. Corrective action synchronized to beam scanning signals and employing ac electrical quantities is termed dynamic convergence. The convergence control components are located on the tube neck behind the deflection yoke where they are enabled to cause sufficient beam path displacement to compensate alignment errors and deflection displacements.

In Fig. 24(a) the magnetic convergence yoke assembly is illustrated. The electron guns are provided

with a mechanical tilt intended to cause undeflected electron beams to initially converge upon the screen. Since this cannot be guaranteed the adjustable magnets provide sufficient static radial displacement to effect this result. However, as shown in Fig. 24(b), an additional lateral displacement control is provided for the blue electron beam. It is necessary to provide four separate kinds of adjustments to satisfy the alignment of the three beams. This is shown in Fig. 24(c) in which the beams are dispersed in a manner that the radial correction provided can only effect a circle (*M*) of minimum displacement. However, the lateral control added to the "blue" beam, and a readjustment of the radial alignment of the "red" and "green" beams, permits precise convergence.

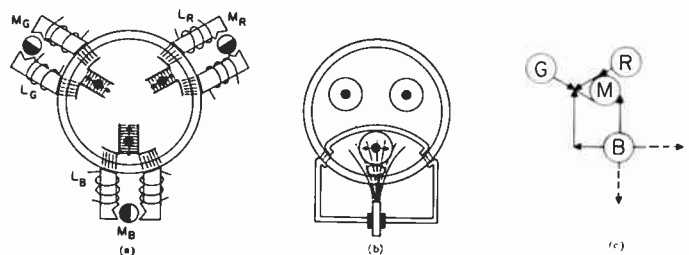

Fig. 24—Convergence diagrams.

The scanning action on the spaced beams distorts the initial beam alignments and causes the appearance of three separate rasters. Deflection increases the beam path distance to the screen but the convergence errors are primarily a result of the defocusing effects accompanying any deflecting field. In either case, the converging elements are required to reduce the convergence angles between beams as a function of the magnitude of deflection. With apparatus made for this purpose, deflection synchronized gating pulses applied to the control grids of the electron guns display triple spot groups on the overall screen area indicative of the deflection distortions. It is the purpose of the dynamic convergence circuits to reduce the displayed spot separations to a minimum.

With three beams originating from equilaterally spaced guns, blue on bottom, red and green in a plane above blue, the kind of spot displacements encountered are such that vertical deflection displaces the blue beam less than the red and green and horizontal deflection produces a greater blue beam displacement. In either condition, the displacements of the red and green beams are more equal and thus more amenable to better convergence. For this reason, the blue gun occupies its particular position; it produces the image with least luminosity and least annoyance when in error. Deflection yoke designs that attempt to equalize the deflected spot separations do provide good convergence performance.

The magnetic convergence yoke is provided with corrective signals which are separately adjustable in mag-

<sup>24</sup> E. G. Ramberg, "Elimination of moiré effects in tri-color kinescopes," *PROC. IRE*, vol. 40, pp. 916-923; August, 1952.

nitude. However only radial motions of the beams are available. Hence complete dynamic convergence is possible for relative beam displacements which are radial only. Lateral convergence errors, illustrated by Fig. 24(c) may accompany the radial displacements. It is this form of distortion that cannot be compensated by the available convergence elements, and effort is expended to reduce these effects in the deflection yoke.

The dynamic correction signals are obtained from the same sources developing the vertical and horizontal scanning currents for the deflection yoke. In this way the corrections are inherently synchronized to the raster. For a well-made deflection yoke, the convergence errors are smooth symmetrical functions that are simulated well enough by parabolic waveforms. These are developed by integration from pulse and sawtooth signals available in the deflection circuits.<sup>25</sup> Where asymmetry is encountered in convergence setup, sawtooth waveforms of either polarity are combined with the parabolic to derive tilted parabolas. The waveforms so developed are applied to the convergence elements which operate to oppose the deflection distortions. Deflection yoke faults such as cross-coupling and capacitive unbalance cannot be corrected by dynamic convergence and are separate, though related, problems.

A convergence circuit for magnetically converged shadow mask tubes achieves circuit simplicity by utilizing resonant ringing in the horizontal current waveforms and by combining the similar corrective requirements of the red and green electron beams. This circuit provides waveforms which are approximations of the desired parabolic waveforms. While the number of adjustments are large, an orderly procedure quickly establishes the optimum registry. Convergence yoke sensitivity is great enough, even though loosely coupled through the glass neck of the tube to the convergence elements, to permit direct excitation from the normal scanning circuits. These tubeless convergence circuits have been quickly adopted for color television receivers.<sup>26</sup>

#### F. White Balance

White balance is the operating condition of the three electron guns that permits the static and dynamic control grid to cathode potentials to vary the picture brightness and contrast while preserving the reference white color. This is necessary for the satisfactory operation of a color receiver in color as well as in monochrome. The white balancing procedures are complicated by the three color phosphors having unequal combining efficiencies and by electron guns having differing electrical characteristics.

The primary color phosphors used in the shadow mask tube have spectral efficiencies approximately as indicated in Fig. 25. Since a typical white color point for a display is composed of nearly equal portions of red,

green, and blue energy, it is apparent the respective electron guns need to supply currents in a compensating inverse order. For a typical white, the red, green, and blue beam currents in the shadow mask tube are generally apportioned to 50, 30, and 20 per cent respectively. However the relative phosphor efficiencies vary from this ratio by wide limits due to manufacturing problems such that the relative red to blue currents may be as high as five to one in a specific picture tube.

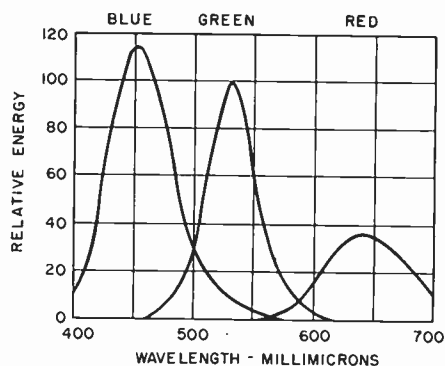

Fig. 25—Relative phosphor efficiencies.

The basic form of the electron guns used in the shadow mask tube is similar to monochrome picture tubes. Cathode emitted current, formed into the focussed and accelerated electron beam is described by:

$$I_K = G \left( -E_{g1} + \frac{E_{g2}}{\mu_{12}} + \frac{E_{g3}}{\mu_{13}} \right)^{2.76}$$

$G$  is a perveance figure largely determined by the first grid to cathode spacing. The spacing is normally 0.005 inch and small variations account for the unavoidable differences between electron guns. Relative to  $g_1$ ,  $\mu_{12}$  and  $\mu_{13}$  are the comparative effectiveness of  $g_2$  and  $g_3$  in controlling the cathode gradient. On the average  $\mu_{12} \approx 3$  and  $\mu_{13} \approx 1,000$ , and the cathode current follows an exponential (gamma) function of the effective electrode voltages of 2.75.

The above expression indicates that sufficient control parameters are available to provide for white balance. However, economic restrictions together with the requirements for definite alignment procedure have led to generally standard circuits.<sup>26</sup>

A typical arrangement based on the video amplifier and matrix circuit of Fig. 23 is based on the following procedures. The luminance signal is driven to the red, green, and blue gun cathodes in an amplitude ratio such as 1.3:1.1:1.0. This is a fixed ratio chosen to keep the range of other parameters listed hereafter within a minimum range. Similarly the color difference signals are coupled to the respective grids (usually with a dc coupling to preserve relative chrominance values) in

<sup>25</sup> J. Giuffrida, "Convergence in the CBS-colortron '205'," *Radio-Elect. Engrg.*, vol. 24, p. 12; February, 1955.

<sup>26</sup> W. M. Quinn, Jr., "Methods of matrixing in an NTSC color television receiver," 1953 IRE CONVENTION RECORD, Part 4, "Broadcasting and Television," pp. 167-172.

fixed ratios properly tuned with the luminance drives. (Of course, the chrominance gain controls the magnitude of the color difference signals but not their relative amplitudes.) To insure a uniformity of receiver power loading the red gun characteristic is normalized by adjusting its  $G_2$  voltage so that an approximate 65 volt black to white signal can just be accommodated between the gun cutoff bias and zero bias. By adjustment of the  $G_1$  and  $G_2$  controls of the green and blue guns the transfer characteristics are matched to the white balance requirements. For these adjustments a combined range of nearly 1,000 volts must be provided between the limits of maximum  $G_1$  and  $G_2$  settings. Background (brightness) adjustments in the circuit of Fig. 23 produce voltage changes proportionate to the luminance drive ratios and thus do not disturb the white balance adjustments.

When the white balancing procedures have been satisfactorily concluded the luminance signal will generate the reference white color on the tricolor tube screen. In effect the primary color phosphors have been combined. The reference white may be Illuminant  $C$ , or another white, depending on the combining ratio. As MacAdam points out, all colors are perceived relative to white and Illuminant  $C$  ( $6,750^\circ\text{K}$ ) is not always satisfactory.<sup>27</sup> He endorses a somewhat more yellowish ( $4,000^\circ\text{K}$ ) white where the picture display is viewed in surroundings illuminated by incandescent lamps and/or daylight. However, a color temperature between  $6,000^\circ\text{K}$  and  $8,200^\circ\text{K}$  appears to be current practice.

### G. Screen Efficiency and High Voltage Power

In the assembly of a tri-color, shadow mask picture tube the manufacturer must follow an uncompromising sequence of accurate operations to make a product with good color purity and brightness. The crux of the tube design is in the relative size of the shadow mask apertures. Analysis has shown that the permissible possible beam current utilization of the phosphor dot screen is 30.3 per cent. This would look encouraging were it not based upon the impossible conditions of zero tolerances of all assemblies and zero beam thickness in preserving color selectivity. As a color pure display over the entire screen area is a requisite, the following practical considerations reduce the screen utilization and brightness performance: finite electron beam diameters, assembly tolerances in manufacturing, and shadow mask thermal shift during operation. The shadow mask tube, as a commercial product, is reduced to an anode power operating efficiency of 9 to 12 per cent compared to a monochrome picture tube operating at 80 per cent or better. Degrading the comparison further, the white combining luminous values of the tri-color phosphors are little better than 50 per cent of average  $P_4$  phosphor screen luminosity. Typical performance for shadow mask

tube type 21AXP22 is a minimum screen brightness of 8 foot lamberts with an ultor current of 800  $\mu\text{amp}$ . Color tube facepanels are usually of "grey" glass of 77 per cent transmission for contrast improvement.

Thus it is apparent that the shadow mask tube may approach monochrome picture tube brightness performance only with greatly increased beam power. However, one limitation is the incident beam power to the shadow mask. The absorbed wattage raises the mask temperature and results in expansion tending to displace the mask apertures from their respective tri-dot groups. Corrective measures include mask blackening to raise its emissivity and mask suspension systems that tend towards thermal compensation. Currently available shadow mask tubes have anode dissipation ratings in the order of 20 watts. At a recommended operating voltage of 25 kilovolts the anode power supply is expected to deliver current at the maximum dissipation rating. Above this value the circuits are designed to fall out of voltage regulation. At the high voltages generated, extraordinary precautions are required to avoid corona and high humidity breakdown.<sup>28</sup>

Anode power, and focus electrode power, are developed in flyback systems quite similar to monochrome television practice. Voltage adder circuits are popular for developing the anode voltage recommended with the use of sufficient series impedance to prevent destructive current surges due to temporary tube flashovers. With flyback supplies, the maximum developed anode power is inherently limited by the fixed operating conditions of the horizontal scan driver tubes so that the shadow mask ratings cannot be much exceeded. The anode supply is voltage stabilized to preserve all the magnetic trimming adjustments made on the anode voltage accelerated electron beams. Otherwise the variable beam current demands would disrupt the setup of color purity, convergence, focus, and raster size.

## V. METHODS OF TESTING COLOR TELEVISION RECEIVERS

### A. Introduction

The purpose of this section is to define methods and outline general manufacturing limits to the reader in testing the performance of color television receivers currently being produced. This discussion will deal with a specific receiver having the functional arrangement of Fig. 26. These circuits have been described; however, a brief description follows to provide the reader with a clear picture of the circuit integration of the receiver under discussion in this section.

### B. The Color Television Receiver

The rf tuner is a modified version of an incremental inductance type used in monochrome receivers. An additional wafer is added to the vhf section to provide

<sup>27</sup> D. L. MacAdam, "Color balance for television," *Proc. IRE*, vol. 43, pp. 11-14; January, 1955.

<sup>28</sup> A. H. Mankin, "Corona suppression methods," *Elec. Mfg.*, vol. 73, p. 125; June, 1951.





tern presents the operator with a convenient means of checking color fit and color quality.

- 5) Convergence test signals are a basic requirement during the assembly of color television receivers. This type of signal is developed by a fifth television transmitter where either a dot or cross-hatch pattern is generated, depending on the test operator's preference.
- 6) A sixth transmitter modulated by a 3.58 mc signal, with variable modulation at a low frequency rate, provides test signals for the proper adjusting and testing of the automatic chrominance circuit.
- 7) Twelve additional transmitters adjusted to the picture carrier of each vhf channel provide signals for overall alignment of the rf-IF and chrominance circuits.
- 8) Crystal controlled pulse generators develop these IF pulses at frequencies of 39.75 mc, 41.25 mc, and 47.25 mc, for setting IF traps and two IF pulses at 41.25 mc and 44.50 mc for checking sound rejection. The pulse markers have their outputs gated with multivibrators which are phase controlled with 60 cycles. Utilizing these pulses in a novel test technique greatly simplifies adjusting traps and checking sound rejection.
- 9) UHF marker generators produce two markers, one at each end of the uhf spectrum, for checking the uhf tuner.
- 10) Crystal controlled generators provide each of the IF alignment intensity markers used to define alignment limits.
- 11) A video signal of the monoscope Indian Head pattern is developed for testing of the deflection circuits.
- 12) Sound carriers of the television transmitters noted above may be modulated with either music or a 400 cycle note for checking various sound circuits.
- 13) A 4.5 mc signal is generated to be used when aligning the 4.5 mc traps and sound IF circuits.
- 14) Bias voltages are developed for alignment purposes. All of the above test signals from the master signal room are considered necessary during the assembly of a color television receiver. In addition, rf, IF, and video sweep signals are generated at the test locations.

#### D. Test Procedure

In the process of manufacturing color television receivers, the various sections of the receiver must be checked, and aligned and pass rigid test specifications. Basically, the receiver goes through eight test operations. In some of these test locations only one group of circuits will be adjusted and tested while in a few test areas the over-all performance of complete receiver is checked to assure that each color receiver will meet engineering specifications before being packed for shipment.

The eight test positions are listed in order below. A brief description of each test location, signal and equipment used and notes on the more important and unusual test operations and techniques will follow:

- 1) VHF rf color tuner.
- 2) VHF-uhf color tuner.
- 3) Deflection test—color television chassis.
- 4) IF alignment—color television chassis.
- 5) RF test—color television chassis.
- 6) Color video alignment—color television chassis.
- 7) Final process—color television instrument.
- 8) Final test inspection—color television instrument.

*VHF-RF Tuner Test and Alignment:* At this location the vhf tuner is aligned up to the link circuit. The link circuit is tuned in the IF test after the rf unit is mounted on the color television chassis. The uhf tuner is aligned during the vhf-uhf color tuner test which follows after this test.

Twelve picture carrier markers are sent to each test location from the master signal room. The equipment required at each location is as follows: vhf sweep generator, vacuum tube volt meter, oscilloscope, and power supply and marker amplifier.

IF markers are obtained by sampling the IF sweep and mixing with a marker at 43.50 mc. A high  $Q$  circuit tuned to 2.25 mc produces a beat at 41.25 mc and 45.75 mc which is then combined with the regular sweep.

When aligning the low channels, the antenna input is loaded with 50 ohms. This is to keep the antenna circuits from changing the response. All channels are rechecked with the load resistor removed and the antenna circuits are then tuned.

RF neutralization is checked to assure a minimum of detuning due to bias changes.

The IF sweep with markers is terminated with 50 ohms at the input of the uhf IF circuit on the vhf tuner. The response is checked with a diode probe and oscilloscope at the mixer plate.

*VHF-UHF Tuner Test and Alignment:* The vhf and uhf tuners have now been assembled as one unit.

At this location an overall sweep on uhf is used to tune the coupling between the two tuners for flatness of response.

The equipment required is as follows: uhf sweep generator, oscilloscope, VTVM, and bias supply.

*Deflection Test:* Here the color television chassis has been completely assembled and ready for its first test. Fig. 27 shows the chassis in its test position and all necessary equipment.

A 21 inch monochrome kinescope with a color yoke is used in this initial test. The red, green and blue video signals can be selected by means of a switch panel shown just to the left of the kinescope in Fig. 27.

An Indian Head video signal is the only source used in this test. This signal is supplied from the master signal room.

The following equipment is required at this test location: monochrome picture tube with color yoke,

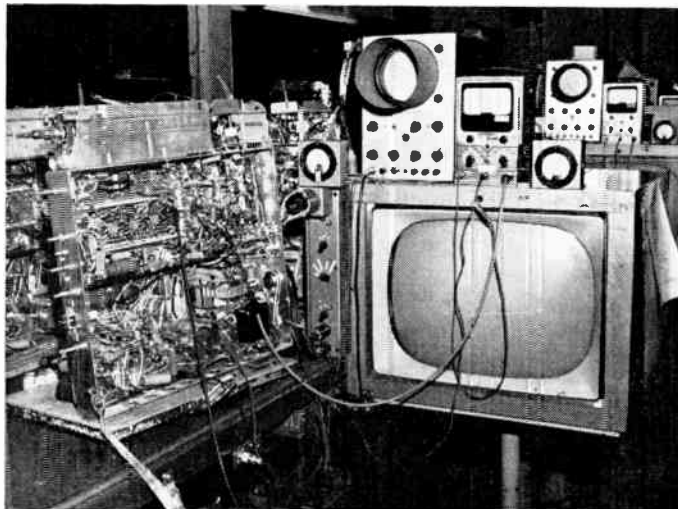

Fig. 27—Deflection chassis test.

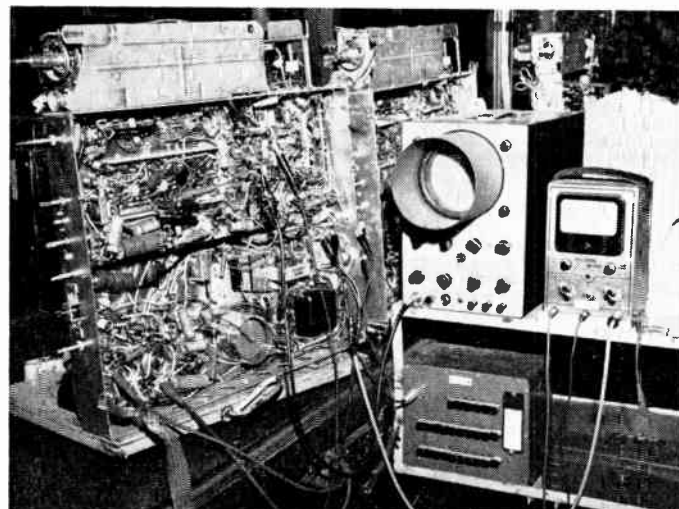

Fig. 28—IF chassis test.

high voltage regulator for 18 kv, 0–1.5 ma meter, 0–500 ma meter, switch panel, convergence coil assembly, oscilloscope, and VTVM.

The deflection test is comprised of the following tests and adjustments:

- 1) The horizontal and vertical hold controls are checked for proper action and are adjusted for picture sync.
- 2) The horizontal drive control is adjusted for disappearance of the white overdrive line.
- 3) The damper current is adjusted for minimum current and the high voltage regulator is adjusted for 25 kv. The regulator current is then checked and should read at least  $750 \mu\text{a}$ . The high voltage may be decreased to a minimum of 23 kv to meet this  $750 \mu\text{a}$  requirement.
- 4) The horizontal oscillator is adjusted for proper pull-in range.
- 5) Action of the width switch is checked.
- 6) The range of the focus voltage is checked.
- 7) The horizontal centering action is checked.
- 8) The voltage range of the three screen controls is checked.
- 9) The voltage range of the background controls is checked.
- 10) The voltage range of each of the three kine cathode signals is checked by varying the brightness control through its range.
- 11) The convergence waveforms are checked on the oscilloscope by going through the range of each of the horizontal and vertical tilt and amplitude controls. The tilt controls are then adjusted to their electrical centers and the amplitude controls adjusted fully CCW.
- 12) The waveform of the horizontal sinewave is checked and properly adjusted.
- 13) Finally each of the three video outputs are checked for a good monochrome picture on the 21-inch monochrome picture tube.

*IF Alignment:* After completion of the deflection test the chassis is given an overall IF test. The sub-assemblies were given a check before they were mounted in the chassis. However, the link circuit and traps have not yet been aligned.

Each chassis is pre-heated before actual alignment. This means that each operator has two receivers in position, one being pre-heated while the other is being aligned.

The IF alignment position similar to the rf position shown in Fig. 28. The equipment required is as follows: oscilloscope, VTVM, and push button test signal selector.

The test signals required are as follows: three trap pulses; 41.25, 47.25, and 39.75, 4.5 mc carrier, sound reject pulses 41.25 and 44.50, IF sweep with intensity markers, and bias supply.

The three trap pulses are crystal controlled and originate from the master signal room. These pulses are gated at a 60 cycle rate and the oscilloscope sweep rate is set at the same frequency. The phase of each pulse is adjusted so the three pulses will be spread across the oscilloscope in the order of their frequency. With this arrangement all the traps in the IF can be adjusted with one setting of the test equipment. Each trap is tuned for minimum pulse height on the oscilloscope.

Sound rejection is also checked by using this pulse method. However, since sound is rejected many times down from 100 per cent IF response, the 100 per cent marker must be attenuated so that a usable ratio can be used for a visual presentation. Thus, the 44.5 mc comparison marker is sent from the signal room approximately 30 times down as compared to the 41.5 mc sound marker. At each test location the scopes are calibrated so the 44.5 mc pulse is a 100 per cent. The 41.25 mc pulse must then fall within limits marked on each scope. The scopes are calibrated against two receivers, with known rejection, one at the high and one at the low limit of sound rejection.

The link coupled circuit and overall IF is adjusted for the proper response. Also, the 4.5 mc carrier is used to check the alignment of the 4.5 mc sound board and tune the 4.5 mc trap in the chrominance circuit.

**RF Test:** At this location the chassis is given a complete rf, IF and video alignment and sensitivity check. The signals required are as follows: All 12 vhf picture carriers mixed with the IF sweep, high level rf—Indian Head test pattern with music, low level rf—Indian Head test pattern with 400 cycle tone, rf video sweep with intensity markers.

The equipment required is as follows: vhf rf sweep generator, uhf rf sweep generator, oscilloscope, rf signal and video sweep selector panel, and bias supply.

The overall response from the antenna terminal to the second detector is checked on all channels both uhf and vhf. Compromise adjustments are made between channels if necessary. The oscilloscope is marked so that the operator can be sure that the receiver is operating within the required limits. A sensitivity check is made by means of an attenuator switch located on the signal selector panel.

The chrominance video circuits are then aligned. An rf carrier modulated with a video sweep with intensity markers is connected to the antenna terminals. A demodulator probe connected to the various test points and the circuits are tuned for the proper responses.

The speaker leads are connected and the operation of the volume and tone controls are checked.

**Color Video Alignment:** At this test location, as seen in Fig. 29, the receiver is connected to a color kinescope for the first time. The screen and background controls are adjusted for a monochrome picture and proper tracking. Height, width, and vertical linearity are properly adjusted. The agc is adjusted for proper signal level at the "bootstrap" circuit using a 30,000  $\mu$ v signal.

The burst gate, APFC, and matrix are checked and aligned at this time. The range of all front panel controls are also checked. The action of the ACC (automatic color control) is checked by means of a 3.58 mc carrier with amplitude modulation varying at a low frequency.

The color killer is adjusted and the receiver is checked on a color bar and Indian Blanket pattern.

Also at this location the dynamic convergence controls are adjusted for proper registration.

The signals required at this test location are as follows: rf—color bars with audio tone, rf—dot pattern, rf—flying spot scanner (Indian Blanket) with sound, rf—modulated 3.58 mc carrier (ACC Signal), rf—Indian Head (high level), rf—Indian Head (low level).

The equipment required is as follows: color kinescope and related accessories, oscilloscope, VTVM, and push button signal selector panel.

**Final Process:** Before arriving at this location the color picture tube and receiver chassis is installed in the

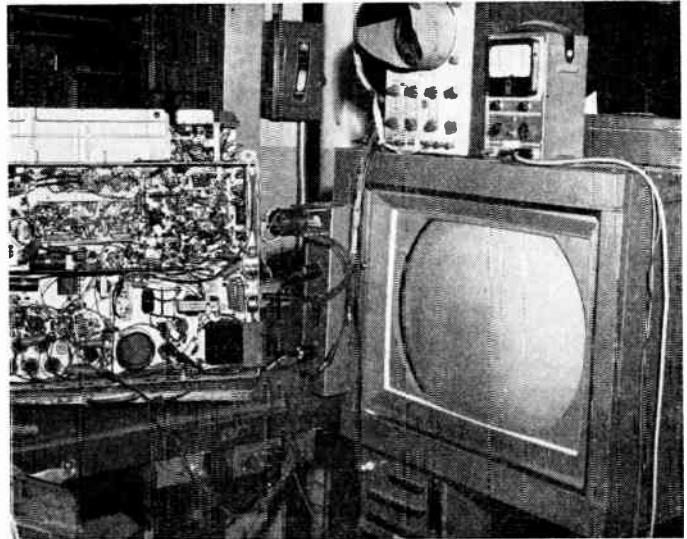

Fig. 29—Color video chassis test.

cabinet and has passed a degaussing unit which is located adjacent to the conveyor.

The height, width, vertical linearity, and focus are rechecked at this time. Next, the yoke, purity magnet, and color equalizer magnets are adjusted to provide proper purity.

Following the purity adjustments, dynamic and static convergence and kinescope color temperature are properly adjusted.

The receiver is again checked for picture and sound sensitivity, for proper color fit within the luminance signal and proper ACC action. The signals used in this test are the same as those used in the color video test.

**Final Test:** At this point the receiver is completely assembled with the top and back in place. It is checked on both vhf and uhf monochrome and color UHF end markers are received from the signal room to check the mechanical range of the uner.

The volume control is turned up so that the presence of sound can be checked. Also all dial and indication lights are checked for operation.

After completion of this test the receiver is packed and made ready for shipment.

#### BIBLIOGRAPHY

- [1] McIlwain, K., and Dean, C. E., *Principles of Color Television*. (In press, John Wiley and Sons, Inc.)
- [2] *A Simplified High Performance 21-Inch Developmental Color Television Receiver, RCA-LB-962* (September 16, 1954).
- [3] National Television System Committee, Report of Panel 14, *Color Synchronizing Standards*, November, 1953.
- [4] Dome, R. B., "NTSC Color Television Synchronizing Signal," *Electronics*, Vol. 25 (February, 1952), pp. 96-97.
- [5] Burgett, M. I., "A Subjective Study of Color Synchronization Performance." *PROCEEDINGS OF THE IRE*, Vol. 41 (August, 1953), pp. 979-983.
- [6] George, T. S., "Analysis of Synchronizing Systems for Dot-Interlaced Color Television." *PROCEEDINGS OF THE IRE*, Vol. 39 (February, 1951), pp. 124-131.
- [7] "The Motorola 19" Color Television Receiver." *Radio and Television News*, vol. 53 (January, 1955), p. 66.
- [8] CBS-Columbia Model 205 Color Television Receiver, Preliminary Service Data.
- [9] Color Television Receiver, Service Data—RCA Victor Model 21-CT-661U.

- [10] *Reference Data for Radio Engineers*. Federal Telephone and Radio Corporation, 3rd ed., p. 136.
- [11] Kirkwood, L. R., and Torre, A. J., "The CT-100 Color Television Receiver." *RCA Review*, Vol. 15 (September, 1954), p. 445.
- [12] GE Receiving Tube Manual.
- [13] Brown, G. H., "The Choice of Axes and Bandwidths for the Chrominance Signals in NTSC Color Television," *PROCEEDINGS OF THE IRE*, Vol. 42 (January, 1954), p. 58.
- [14] Bedford, A. V., "Mixed Highs in Color Television," *PROCEEDINGS OF THE IRE*, Vol. 38 (September, 1950), pp. 1003-1009.
- [15] Seely, S., *Electron Tube Circuits*. New York, N. Y., McGraw-Hill Book Company, 1950, pp. 148-150.
- [16] Quinn, Jr., William, "Methods of Matrixing in an NTSC Color Receiver," 1953 IRE CONVENTION RECORD, Part 4, "Broadcasting and Television," pp. 162-172.
- [17] Feingold, W. R., "Matrix Networks for Color Television," *PROCEEDINGS OF THE IRE*, Vol. 42 (January, 1954), pp. 201-203.
- [18] Clark, E. G., and Phillips, C. H., "Color Demodulators for Color Television." *Electronics*, vol. 27 (June, 1954), pp. 164-169.
- [19] Kiver, M. J., "Fundamentals of Color Television." *Radio and Television News* (November, 1954), pp. 63-65.
- [20] Duetch, *Theory and Design of Television Receivers*. McGraw-Hill Television Series, Chapter 7, Video Amplifier and DC restorers.
- [21] Wendt, K. R., "Television DC Components." *RCA Review*, vol. 10 (March, 1948), pp. 85-111.
- [22] Federal Communication Commission Rules Part 3—Rules Governing Radio Broadcast Stations especially 3.681, 3.682, and 3.687.
- [23] Teasdale, R. D., "Magnetic Alloy Shields for Color Television Tubes." *Tele-Tech*, Vol. 12 (December, 1953), p. 74.
- [24] Bingley, F. J., "Transfer Characteristics in NTSC Color Television." *PROCEEDINGS OF THE IRE*, Vol. 42 (January, 1954), pp. 71-78.

## The Transfluxor\*

J. A. RAJCHMAN†, FELLOW, IRE AND A. W. LO†, ASSOCIATE MEMBER, IRE

**Summary**—The transfluxor comprises a core of magnetic material with a nearly rectangular hysteresis loop and having two or more apertures. The control of the transfer of flux between the three or more legs of the magnetic core provides novel means to store and gate electrical signals. The transfluxor can control, for an indefinitely long time, the transmission of ac power according to a level established by a single setting pulse. This level can have any value in a continuous range, from no transmission to some maximum, thus affording either "on-off" or "continuous" stored control. These properties of the transfluxor, possessed by no other passive element, render it a significant addition to the list of basic circuit components presently employed in electronics.

The characteristics of a representative two-aperture transfluxor are described. The device has high efficiency of power transmission, short setting time, negligible coupling between setting and output circuits and sharp setting thresholds. Several illustrative applications are given, including nondestructive readout memory systems and channel selector switches. Several examples of transfluxors with more than two apertures are described.

### INTRODUCTION

IN A RECENT paper<sup>1</sup> the authors have announced a novel device showing that completely new switching and storing functions can be performed by employing magnetic cores with two or more apertures,<sup>2</sup> instead of the conventional single aperture cores, thereby creating a number of distinct flux paths via the legs of the core. The new device operates by the controlled

transfer of flux from leg to leg in the magnetic circuit and was consequently named TRANSFLUXOR.

One of the most important properties of the transfluxor is its ability to store a level of control established by a single electric pulse. An energizing ac drive will or will not produce an ac output depending upon the nature of the last setting pulse to which the transfluxor was subjected. Furthermore, intermediate setting is possible for which an output of any desired level in a continuous range between almost zero and a maximum level will be produced according to the amplitude of a single setting pulse.

In the present paper, after a short review of the principle of the new device, its operation is illustrated in detail by the characteristics of a typical two-apertured transfluxor and some of its applications. Several examples of logical functions attainable with multi-apertured transfluxors are also included.

### PRINCIPLE OF THE TWO-APERTURED TRANSFLUXOR

Consider a core made of magnetic material such as a molded ceramic "ferrite" which has a nearly rectangular hysteresis loop and consequently a remanent induction  $B_r$  substantially equal to the saturated induction  $B_s$ . Let there be two circular apertures of unequal diameter which form three distinct legs, 1, 2, and 3 in the magnetic circuit, as illustrated in Fig. 1. The areas of the cross sections of the legs 2 and 3 are equal and the cross section of leg 1 is equal to, or greater than, the sum of those of legs 2 and 3.

The operation of the device previously explained<sup>1</sup> is reviewed here for convenience. Assume that at first an intense current pulse is sent through winding  $W_1$  on leg 1 in a direction to produce a clockwise flux flow which

\* Original manuscript received by the IRE, November 14, 1955; revised manuscript received, December 15, 1955.

† RCA Laboratories, Princeton, N. J.

<sup>1</sup> J. A. Rajchman and A. W. Lo, "The transfluxor—a magnetic gate with stored variable setting," *RCA Rev.*, vol. 16, pp. 303-311; June, 1955.

<sup>2</sup> Magnetic circuits using multi-aperture cores have also been reported by: R. L. Snyder, "Magnistor circuits," *Elect. Design*, vol. 3; August, 1955. R. Thorensen and W. R. Arsenault, "A new nondestructive read for magnetic cores," a paper presented at the Western Joint Computer Conference; March, 1955.

saturates legs 2 and 3. This is possible since the larger leg 1 provides the necessary return path. These legs will remain saturated after the termination of the pulse since remanent and saturated inductions are almost equal. Consider now the effect of an energizing alternating current in winding  $W_3$  linking leg 3, producing an alternating magnetomotive force along a path surrounding the smaller aperture, but of insufficient amplitude to produce significant flux change around both apertures, as shown by the shaded area in Fig. 1. When this magnetomotive force has a clockwise sense, it tends to produce an increase in flux in leg 3 and a decrease in leg 2. But no increase of flux is possible in leg 3 because it is saturated. Consequently, there can be no flux flow at all, since magnetic flux flow is necessarily in closed paths. Similarly, during the opposite phase of the ac, the magnetomotive force is in a counter-clockwise sense and tends to produce an increase in flux in leg 2, which is again impossible since that leg is saturated. Consequently, flux flow is "blocked" as the result of the direction of saturation of either leg 2 or 3. The transfluxor is in its "blocked" state and no voltage is induced in an output winding  $W_0$  linking leg 3.

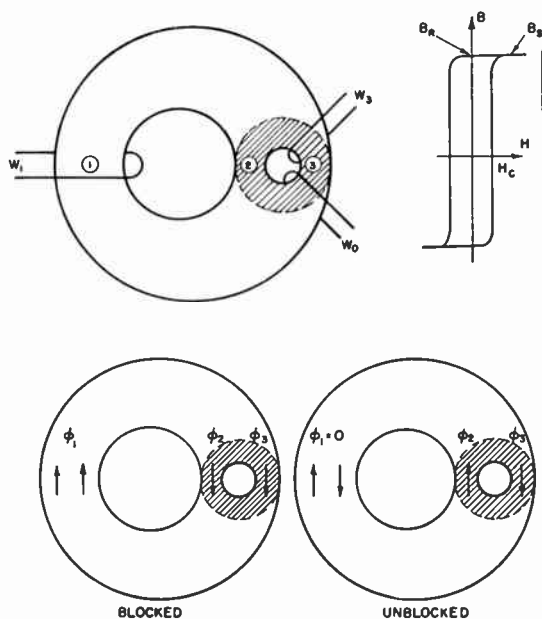

Fig. 1—Principle of transfluxor.

Consider now the effect of a current pulse through winding  $W_1$  in a direction producing a counter-clockwise magnetomotive force. Let this pulse be intense enough to produce a magnetizing force in the closer leg 2 larger than the coercive force  $H_c$ , but not large enough to allow the magnetizing force in the more distant leg 3 to exceed the critical value. This pulse, called hereafter the "setting pulse," will cause the saturation of leg 2 to reverse and become directed upwards (Fig. 1), but will not affect leg 3 which will remain saturated downward.

In this condition, the alternating magnetomotive force around the small aperture resulting from the alternating current in winding  $W_3$  will produce a corresponding flux flow around the small aperture. The first counter-clockwise phase of the ac will reverse the flux, the next clockwise phase will reverse it again, and so on indefinitely. This flow may be thought of as a back-and-forth "transfer" of flux between legs 2 and 3. The alternating flux flow will induce a voltage in the output winding  $W_0$ . This is the "unblocked" or "maximum set" state of the transfluxor.

It is seen that the transfluxor is blocked when the directions of remanent induction of the legs surrounding the smaller aperture are the same and unblocked when they are opposite. In the blocked state the magnetic material around the small aperture provides essentially no coupling between the primary ( $W_3$ ) and secondary ( $W_0$ ) windings, while it provides a relatively large coupling between these two windings in the unblocked state. It is interesting to note that the information as to whether the transfluxor is blocked or unblocked can be thought of as being stored in terms of the flux through leg 1, and that this stored flux does not change when output is produced by interchange of flux between legs 2 and 3.

The transfluxor can also be set to any level in a continuous range in response to the amplitude of a single setting current pulse. Once set, it will deliver indefinitely an output proportional to the setting. This may be explained with simplifying idealizations as follows: Consider first the transfluxor in its blocked condition. Let there be a "setting" current pulse through winding  $W_1$  of a chosen amplitude and, of course, of a polarity opposite that of the original blocking pulse. A magnetizing force  $H$ , proportional to this current, is produced around the large hole. This force in the magnetic material is greatest at the periphery of the hole and diminishes gradually with distance. In the case of a circular aperture it is inversely proportional to the radius. Therefore, for the given selected amplitude of the setting current pulse, there will be a critical circle separating an inner zone, in which the magnetizing force is larger than the threshold magnetizing force  $H_c$  required to reverse the sense of flux flow, and an outer zone, where this field is smaller than the threshold value. These two zones are shown in Fig. 2. Consider now the alternating magnetomotive force on leg 3 produced by an indefinitely long sequence of pulses of alternating polarity. The first pulse, applied to leg 3 in a direction to produce downward magnetization in leg 2, can change only that part of the flux in leg 2 which is directed upwards, namely that part which has been "set" or "trapped" into that leg by the setting pulse. This changing part of the flux will flow through leg 3 until leg 2 reaches its original downward saturation. The amount of flux set into leg 2 is therefore transferred to leg 3.

The next pulse, applied to leg 3, will saturate it to its original downward direction and thereby retransfer the trapped amount of flux back to leg 2. There is no danger of any transfer of flux to leg 1, since the magnetizing path is much longer through that leg, and once leg 3 is saturated no further flux flow is possible however intense this second pulse. It is apparent therefore, that the succession of pulses of alternating polarity on leg 3 will cause reversing of an amount of flux around the small aperture just equal to that initially set into leg 2.

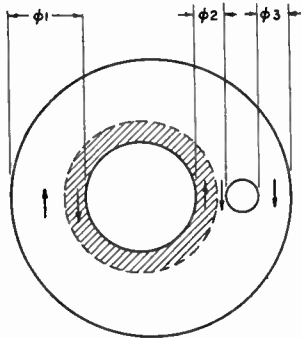

Fig. 2—Setting the transfluxor to a level in a continuous range.

It is convenient to consider this flux flow as an "interchange" or "transfer" of flux between leg 2 and leg 3, a basic concept of the transfluxor. This will produce across the output winding  $W_0$  an indefinitely long train of voltage pulses. The magnitude of the output or the "analog" information can be thought as stored in terms of the flux in leg 1 (or algebraic sum of fluxes in legs 2 and 3), just as was the case for the "on-off" information. This stored flux is not affected by the output-producing interchange of flux between legs 2 and 3.

There is a possibility that, in the blocked condition, or any intermediary set condition, a sufficiently large ac in the phase tending to produce counterclockwise flux flow could in fact change the flux in leg 3 by transferring flux to leg 1. There is, therefore, a limit to the permissible amplitude of the energizing ac because of the possibility of "spurious unblocking." The limiting amplitude is increased by the use of unequal hole diameters rendering the flux path via legs 1 and 3 much longer than via legs 2 and 3. There is no danger of spurious unblocking by the ac in the phase tending to produce a clockwise flux flow, since in this phase leg 3 is being magnetized in the direction in which it is already saturated. Therefore, there is a considerable advantage in using asymmetric energizing alternating current or a train of interlaced relatively large "driving" pulses (clockwise) and relatively small "priming" pulses (counter-clockwise). The driving pulses, which cannot possibly spuriously unblock a blocked transfluxor, can be arbitrarily large, with the result that when the

transfluxor is unblocked by proper setting, these pulses may not only provide the required minimal reversing magnetizing force around the small aperture, but also provide substantial power to deliver large output currents. The priming pulses must be of sufficient magnitude to provide the required magnetizing force around the small aperture, but insufficient to provide it around both apertures.

#### THE PROTOTYPE TWO-APERTURED TRANSFLUXOR

##### *Inherent Characteristics*

The core of the transfluxor for which the characteristics are given below was made of magnetic ceramic material (manganese-magnesium ferrosphenel—30 per cent MnO, 30 per cent MgO, 40 per cent  $F_2O_3$ ), of composition and processing identical to those used for memory cores. The dimensions are shown on Fig. 3.

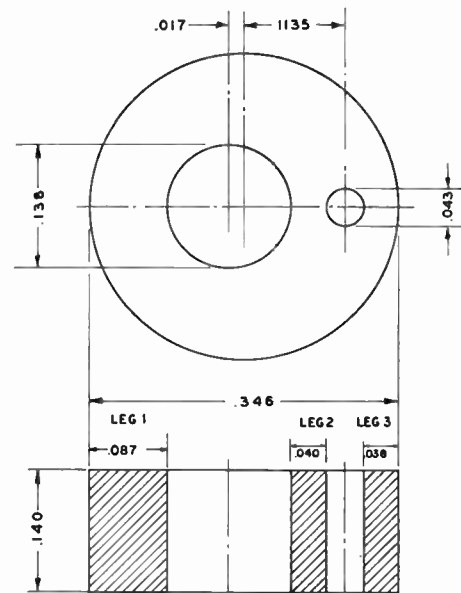

Fig. 3—The prototype transfluxor.

The knowledge of the actual amounts of flux set in leg 2 and leg 3 by a pulsed magnetomotive force applied to leg 1 can be used to evaluate the idealized explanation of the operation given above as well as to predict the detailed operation. These inherent setting properties, illustrated on Fig. 4, were obtained as follows: leg 1 was subjected first to a relatively large blocking pulse of 5 ampere turns (AT) of magnetomotive force and then to a setting pulse the amplitude of which is the abscissa of the plot. The instantaneous voltages on one-turn windings linking legs 2 and 3 were integrated throughout the duration of the setting pulse including the rise and decay of the pulse. These integrated values are the irreversible (or net) flux changes  $\phi_2$  and  $\phi_3$  produced by the setting, and are shown as the ordinates of the plot.

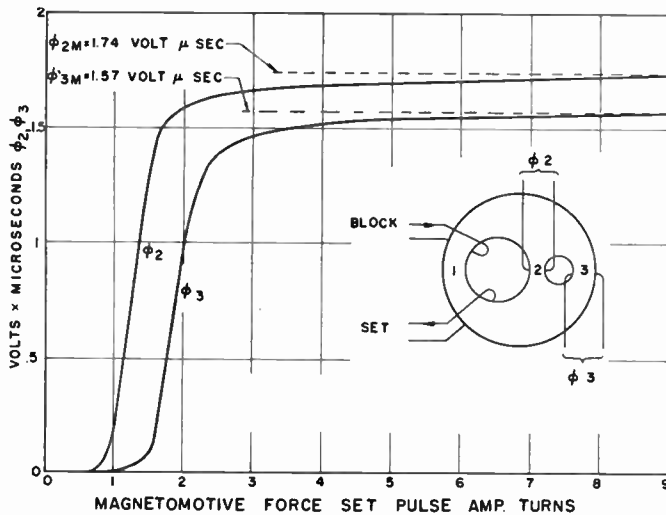

Fig. 4—Inherent setting characteristic.

Ideally, the variations of the fluxes  $\phi_2$  and  $\phi_3$  can be predicted by considering the location of the closed line of magnetic induction passing through leg 1 along which the magnetizing force, due to the set current, is just equal to the threshold magnetizing force required to reverse the sense of flux flow, as was explained above. This boundary between reversed and non-reversed senses of flux flow is approximately a circle the radius of which increases linearly with setting current. No flux change occurs until this circle reaches the edge of the large aperture ( $\phi_2 = \phi_3 = 0$ ). After this first threshold is exceeded, the flux in leg 2 increases linearly with the radius of the limiting circle as it sweeps across the width of the leg, while the flux in leg 3 remains zero. When the limiting circle has reached the smaller aperture, the direction of flux across the entire width of leg 2 is reversed. A further increase of setting current will increase the length of the boundary, which may then deviate somewhat from a circle, until it reaches the inner edge of leg 3. At this second threshold value, the flux in leg 3 will start to increase linearly until the boundary has swept across the entire width of that leg.

The curves of Fig. 4 only approximate the sectionally linear curves predicted by the above idealization, because the real material is characterized by a family of hysteresis loops deviating appreciably from the ideal rectangular shape. The "rounding-off" of the corners and the asymptotic saturation characteristics are, therefore, not surprising. It is worth noting that leg 3 exhibits a substantial flux setting before leg 2 reaches saturation and also that its saturated value is smaller because the width of this leg happens to be somewhat narrower than that of leg 2 (see Fig. 3).

#### OPERATING CHARACTERISTICS

The amount of flux which is interchanged between legs 2 and 3 for a given setting by priming and driving

pulses, determines the output from the transfluxor and will be referred to as "the output flux." The setting pulse will determine the maximum interchangeable amount of flux while the priming and driving pulses will determine what part of that flux is actually interchanged. It is convenient to consider the plots of the output flux as a function of the setting magnetomotive force as "setting characteristics" for given priming and driving pulses. "Driving characteristics" are the plots of the output flux as a function of the driving pulse for given setting and priming pulses. Main mode of operation consists of blocking and setting on leg 1, priming and driving on leg 3 and deriving output from leg 3. Two cases are of interest: asymmetrical energization consisting of unequal drive and prime pulses useful when efficient loading is desired, and symmetrical energization consisting of equal drive and prime pulse or sinusoidal current encountered in small signal ac transmission.

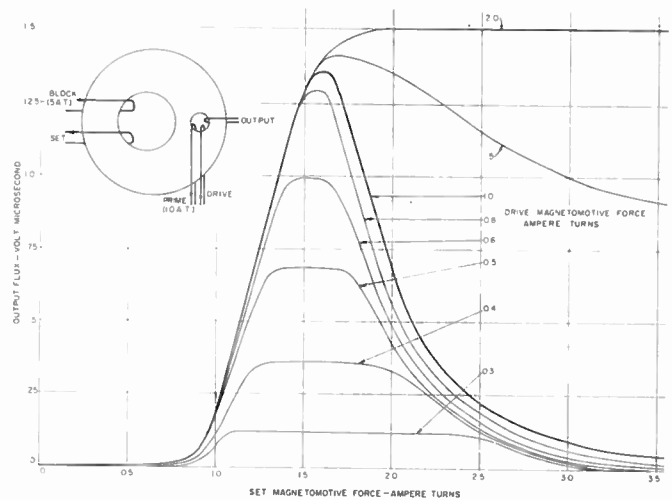

Fig. 5—Setting characteristic—asymmetrical energization.

The setting characteristics for asymmetrical energization shown in Fig. 5, can be explained as follows: the flux change  $\phi_{1S}$  in leg 1, set into it by the setting pulse, will divide itself, in general, between legs 2 and 3 where the changes of flux  $\phi_{2S}$  and  $\phi_{3S}$  will be produced ( $\phi_{1S} = \phi_{2S} + \phi_{3S}$ ). When the set flux  $\phi_{1S}$  is smaller than the maximum flux containable in the narrowest leg (in this case leg 3, which is slightly narrower than leg 2), the setting is referred to as "normal." For normal setting the first prime pulse on leg 3 will saturate leg 2 in its original blocked direction of saturation, transferring the flux  $\phi_{2S}$  set in leg 2 to leg 3, thereby concentrating the amount of flux equal to  $\phi_{1S}$  in leg 3. When the drive pulse is of an amplitude just sufficient to saturate the entire width of leg 3 (1 AT), the flux concentrated in that leg by the prime pulse, will be retransferred to leg 2. The steady-state interchanged output flux between legs 2 and 3 will, therefore, be precisely that set initially in leg 1, which in turn is equal to the sum of fluxes  $\phi_2$



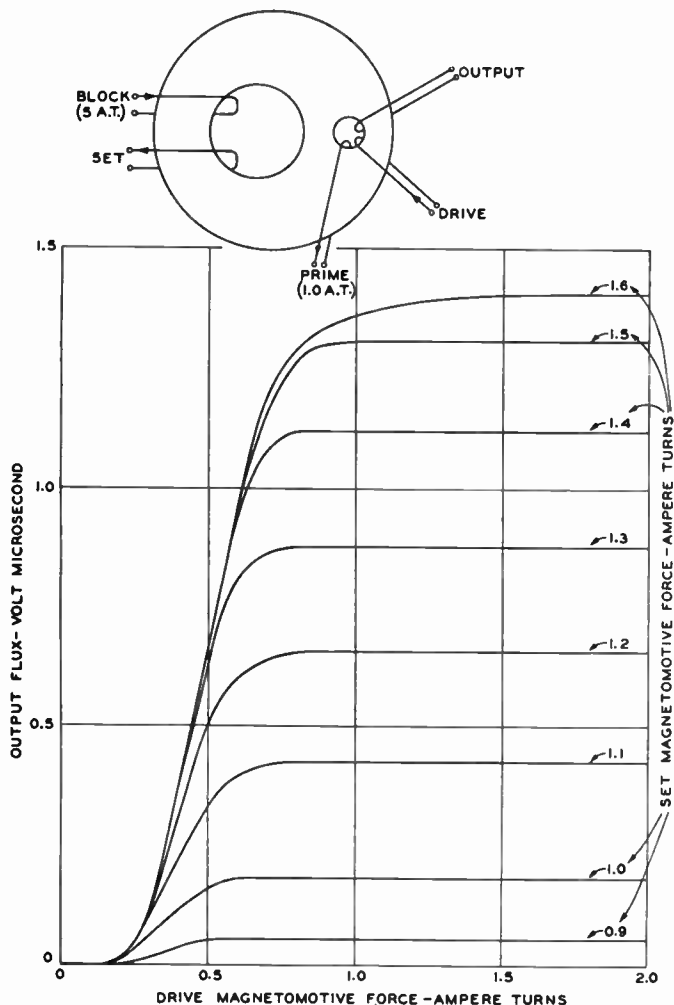

Fig. 6—Driving characteristic—asymmetrical energization.

pulse on leg 3 will saturate it completely in the original blocked downward direction by transferring flux first to leg 2 until it is saturated and then the excess to leg 1. Therefore an overset and overdriven transfluxor will produce the maximum output, as shown by the characteristic curves of Fig. 5.

The driving characteristics of Fig. 6, for the same asymmetrical energization, show that arbitrarily large driving pulses may be used without disturbing normal setting as was explained before. There is a threshold value of 0.2 AT, corresponding to the value of magnetomotive force producing a magnetizing force just equal to the coercive force at the periphery of the small aperture, below which there is no interchange of flux between legs 2 and 3. Each curve exhibits a sharp threshold followed by an approximately linearly rising curve.

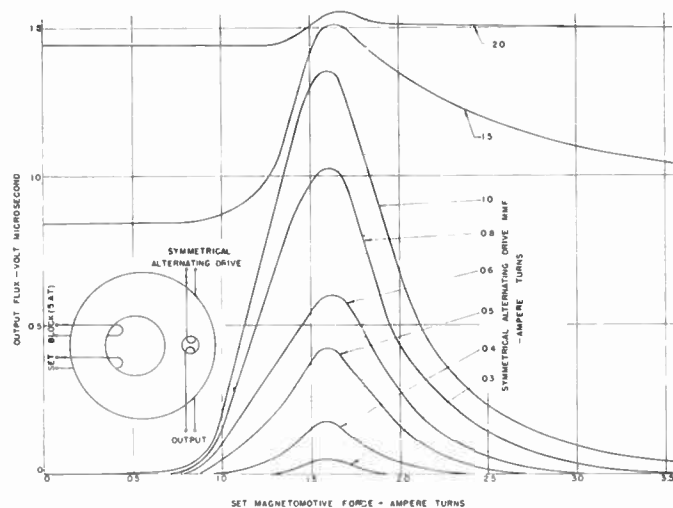

Fig. 7—Setting characteristic—symmetrical energization.

and  $\phi_3$  shown on the inherent set curves of Fig. 4. This flux increases linearly up to the limit of normal setting which is about 1.5 AT.

When the drive is not sufficient to transfer all the flux of leg 3 back to leg 2, only a part of the interchangeable flux set in leg 3 will be, in general, actually interchanged. This explains the shape of the setting characteristic for lower drives (less than 1 AT). These curves follow the main characteristic only up to the value of drive for which the whole set-in flux can be transferred.

When the flux  $\phi_{1,S}$  set in leg 1 exceeds that containable in the widest of the two legs, 2 or 3, it "oversets" the transfluxor by starting to reverse the fluxes in all legs, producing blocking. Therefore, the amount of output flux interchanged between legs 2 and 3 diminishes. The rate of decrease of the output flux with increasing setting current is smaller in the overset region than the rate of increase in the normal region because of the asymptotic nature of the curve near saturation (see Fig. 4). The loss of output flux due to oversetting may be corrected by overdriving. A large enough driving

The setting characteristics for symmetrical energization with equal drive and prime pulses, shown on Fig. 7, may be explained by considering first the idealized situation for a normal setting in which two zones are created in leg 2; one near the larger aperture where the flux is reversed and one near the smaller aperture where it remains unaffected (see Fig. 8). When the prime pulse on leg 3 is insufficient to produce a magnetizing force greater than the coercive force at the location of the boundary between the two zones, no flux will be transferred to leg 3. There will be a definite value of prime for a given setting, for which transfer will start to occur. The amount of transferred flux will be proportional to that portion of the cross section of leg 2 which is included between the boundary separating the set and nonset zones around the larger aperture and the boundary between the primable and non-primable zones around the small aperture, as shown in Fig. 8. This flux increases with setting, for a given prime, at a rate which is independent of the priming value. When the priming pulse becomes large enough to produce

interchange of flux between legs 3 and 1, it will effectively produce a setting of leg 1 even when no previous setting on leg 1 was applied. This is the spurious "un-blocking" due to symmetrical drive and prime mentioned earlier. The characteristics of Fig. 7 have approximately the shape to be expected from these considerations.

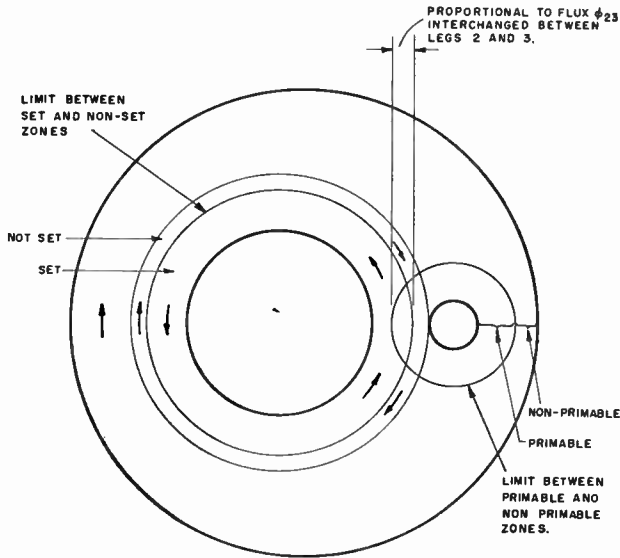

Fig. 8—Zones of setting and primability in the transfluxor.

The driving characteristics for the symmetrical energization case are shown in Fig. 9. The range of the priming pulses, and consequently also of the driving pulses, is restricted to the values (up to 1 AT) which do not produce spurious settings. For a given setting, the amount of interchangeable output flux is proportional to the flux in leg 2 which is both set and primable. The threshold value of prime, below which no flux is interchanged, is smaller the greater the set, since the boundary between set and non-set zones is closer to the small aperture in this case.

In the main mode, with either a symmetrical or symmetrical energization, the input control (setting) circuits are completely separated from the output circuits, since the block and set winding is on leg 1 and the priming, driving and output windings are on leg 3. There is negligible coupling between the control and output circuits because there is practically no interchange of flux between legs 1 and 3 in normal operation. For example, in the prototype transfluxor set to maximum, the back-and-forth interchange of flux between legs 2 and 3 is 1.5 voltmicroseconds, and this is accompanied by only 0.01 voltmicrosecond of flux change in leg 1, or less than 1 per cent. Furthermore, normal setting pulses produce only slight changes of flux in leg 3, of only about 5 per cent of the flux set into leg 2 by maximum setting. If blocking occurs after driving, rather

than priming, it produces a negligible flux change in leg 3 since the drive pulse has already saturated that leg in the direction of blocking.

An arbitrarily large priming pulse, rather than one needing to be of a prescribed amplitude, can be used by priming on leg 2 rather than on leg 3. After normal setting, the prime pulse will saturate leg 2 downward to its original blocked direction and transfer flux to leg 3 rather than leg 1 because the flux path is shorter. In the case of a low impedance load on leg 3, the load current during priming may cause some of the flux in leg 2 to flow through leg 1 rather than leg 3. This may be prevented by slow priming or by the use of an isolation

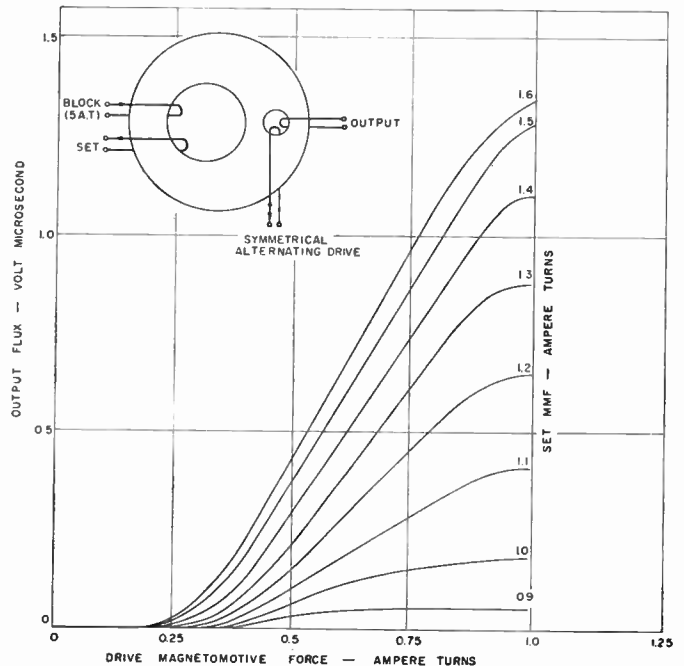

Fig. 9—Driving characteristic—symmetrical energization.

diode in the load circuit. A further increase of the prime pulse on leg 2 produces no further flux change because leg 2 is saturated. When the transfluxor is overset, the prime pulse on leg 2 transfers to leg 3 that part of its flux that leg 3 can accept and forces the excess flux to leg 1, where it readjusts the setting. Oversetting is thus corrected for by the first prime pulse which causes the transfluxor to be set for maximum output. In this mode of priming on leg 2, the setting pulse induces a voltage in the prime winding. Thus, there is an interaction between setting and priming circuits. This interaction can be tolerated in the many practical cases in which the priming winding is in the plate circuit of a vacuum tube.

In some "on-off" applications of the transfluxor, it is convenient to set on leg 2 rather than on leg 1 to avoid the possibility of oversetting. The setting amplitude is not critical as long as it is greater than some required

minimum (about 1.3 AT). In this case the large setting pulse producing an upward magnetomotive force on leg 2 forces the flux of leg 2 to reverse its blocked direction. Since flux flow through leg 3 is impossible, necessary continuity of flux is satisfied by an interchange of flux between legs 2 and 1, which leaves leg 1 with practically zero flux and leg 2 with an upward saturation. This is the "unblocked" state of the transfluxor. The pulses on legs 1 and 2 serve respectively as the "blocking" and "unblocking" pulses and close or open the transfluxor gate. In this mode there is direct coupling between setting winding on leg 2 and output, since output flux is precisely the interchangeable flux between legs 2 and 3. Again this coupling is tolerable in many practical cases; *e.g.*, when setting winding is in the high impedance circuit of a vacuum tube. It is possible also to use leg 2 both for setting and priming.

#### OUTPUT FROM THE TRANSFLUXOR

The transfluxor exercises control by means of the amount of flux which can be transferred for an indefinitely long time between legs 2 and 3, and which amount can be set by a single pulse to any desired value in a continuous range. This back-and-forth transfer of flux between legs 2 and 3 can be considered also as a back-and-forth reversal of flux around the small aperture along a path which is effectively the output magnetic circuit and may be characterized by a conventional hysteresis loop relating the flux flow and the magnetomotive force on leg 3 producing it. Fig. 10 shows a photograph of oscilloscope traces of a family of such loops, each obtained for a different setting including the blocked and maximum settings.

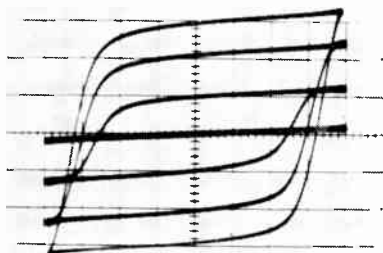

Fig. 10—Hysteresis loops of the output magnetic circuit for various settings.

It is apparent that the transfluxor operates as if the output magnetic circuit consisted of a conventional one-apertured core with the essential property that the effective cross-sectional area of that core can be adjusted by a single set pulse to any desired value from practically zero to a maximum value equal to the physical cross-sectional area of its smallest leg.

The relations which exist between the primary and secondary circuits of a pulse transformer apply equally well to the output circuit of the transfluxor provided

account is taken of the definite "set" cross-sectional area of the equivalent core and the properties of the material of the core. These include the shape of the hysteresis loops and the intrinsic possible rates of flux reversal. The salient properties of the output circuit can be illustrated by the cases of very high and very low-impedance loading.

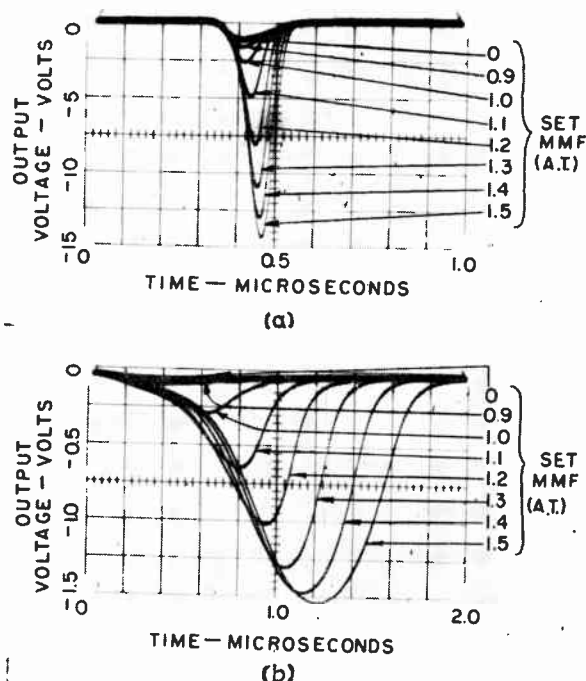

Fig. 11—Voltage output wave forms for open circuit. (a) Large drive. (b) Small drive.

Output voltage wave forms are shown in the oscilloscope trace photographs of Figs. 11a and 11b for the case of an open-circuited output winding; *i.e.*, a very high impedance load. The traces are for the various values of setting, as indicated. For the relatively large (5 AT) and fast rising ( $3.3 \text{ AT}/\mu\text{sec}$ ) drive of Fig. 11a and for the relatively small (1 AT) and slow rising ( $.7 \text{ AT}/\mu\text{sec}$ ) drive of Fig. 11b, the voltage peaks vary linearly with the current settings. The unloaded transfluxor may therefore be considered as a device furnishing a controllable voltage. The short flux-reversal time of  $.1 \mu\text{sec}$  for large drive is noteworthy.

The ratio of voltage output at maximum setting (1.5 AT) to that at zero setting or blocked condition, is 15 to 1 for the large drive of Fig. 11a and 50 to 1 for the smaller drive of Fig. 11b. The slight voltage output in the blocked condition results from the "elastic" or reversible flux excursion due to the lack of perfect saturation at remanence of the material composing the transfluxor's core. There is actually no measurable irreversible output flux for zero setting. (See Figs. 5 to 7 and 9.)

The output voltage wave forms developed across a

very low resistance load, for different settings, are shown in Fig. 12a. The setting is seen to control the duration of the pulses rather than the voltage maxima which are very flat and almost the same for all settings. This results from the fact that the counter-magnetomotive force due to the secondary current tends to keep the rate of change of flux constant. The output currents in a low resistance load for a transfluxor set to maximum and primed on leg 3 by a pulse of one ampere-turn lasting a few microseconds, are shown in Fig. 12b for different drive currents. The output current increases linearly with drive current; the heavily loaded transfluxor may therefore be considered to be a current transformer. The efficiency of power transmission is high for large drives since only a small part of the drive is wasted in magnetizing the output magnetic circuit and the major part neutralizes the secondary counter-

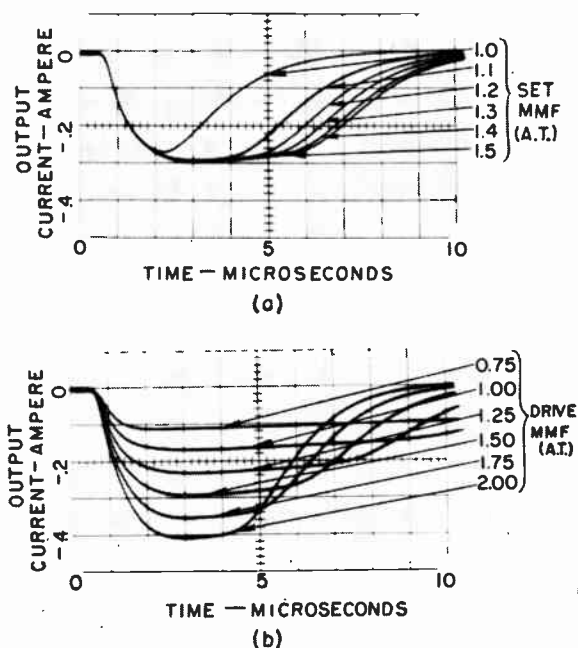

Fig. 12—Voltage output wave forms for low resistance load. (a) Various settings. (b) Various drives.

magnetomotive force and produces the output current. Efficiencies of 75 per cent have been obtained. This important property of the transfluxor reflects the advantage of using unsymmetrical output circuit energization; *i.e.*, small and slowly rising priming current pulses producing negligible output and no spurious setting, and fast-rising, large-amplitude drive pulses producing the useful output.

In the above illustrations the transfluxor was used as an adjustable transformer with a primary winding energized by a current generator and a secondary winding carrying the load. In many applications it is convenient to use it as an adjustable inductance with a single winding (on leg 3) in series with a voltage gen-

erator and the load. In that case a high output is obtained when the transfluxor is blocked and a low output when it is unblocked, but besides this inversion, all operations as an inductance or as a transformer are similar.

The material composing the core of the prototype transfluxor permits short switch-over times. Conventional memory core, made of this material switch in about  $1.5 \mu\text{sec}$  when driven by a current giving optimum discrimination in a two-to-one driving system. In the range of setting pulse amplitudes shown in the operating characteristics the setting requires about  $2 \mu\text{sec}$ . As was noted very much shorter output pulses are possible when strong drives are used. The repetition rates of the driving and priming pulses or the frequency of sinusoidal ac energization can be one megacycle or more without any appreciable heating of the core of the transfluxor. There is no lower limit to the frequencies used in the output circuit, other than that imposed by the practical use of the low voltages resulting therefrom.

#### APPLICATIONS OF THE TRANSFLUXOR

##### *Information Registers for Digital Computers*

The transfluxor can be operated as an on-off gate utilizing only the blocked and the set-to-maximum or unblocked settings. The amplitude of the blocking pulse on leg 1 is not critical provided it is greater than some minimum. Similarly the unblocking pulse can be rendered uncritical if applied to leg 2, as was mentioned above, or if a third setting aperture is provided, as will be described. In this operation the transfluxor performs the same function in digital computing applications as does a gate controlled by a conventional tube or transistor flip-flop. Once set, the gate remains open or closed without requiring any holding power. A bank of transfluxors constitutes a register for storing a number of binary signals from which read-out signals can be obtained any number of times without destroying the stored information. These signals can be conveniently generated from a common source gated by the individual transfluxors. No signals in the setting circuits result from the interrogation when proper arrangements are made.

##### *Random Access Memory with Nondestructive Read-out*

An array of transfluxors can be used as a random access memory with so-called nondestructive read-out; *i.e.*, where the read-out is obtained without changing at any time the physical state representing the information. The two stored states are the blocked and unblocked remanent conditions of the transfluxor. Current coincidence can be utilized for selection, as is done in conventional core memories. Consider two selecting windings on leg 1 and two selecting windings on leg 3 of

each transfluxor. Let these windings be connected in series by rows and columns as shown for simplicity by single linking wires on Fig. 13. Address selecting writing pulses are applied simultaneously to one row and one column winding linking leg 1. The additive effect of these pulses on the selected transfluxor at the intersection of the row and column windings is sufficient to produce a setting, but the amplitude of the pulses is insufficient to affect the transfluxors on which they act singly. The direction of the writing pulses determines whether the selected transfluxor is set to the blocked or unblocked condition. Reading, based also on current

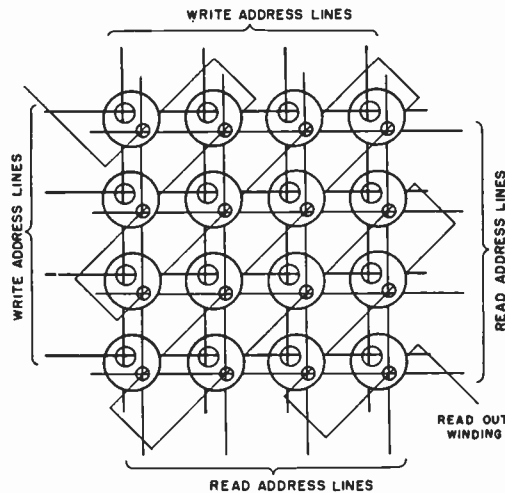

Fig. 13—Array of transfluxors used as random access memory with nondestructive read-out.

coincidence selection, is obtained by applying pulses of the proper amplitude to the selected row and column winding linking leg 3. A read-out is obtained by a pair of pulses on each selecting line, one in the prime and one in the drive directions. As a result, fluxes in legs 2 and 3 reverse back-and-forth and return to their initial state, if the transfluxor is unblocked; or remain in that initial state, if the transfluxor is blocked. These flux reversals can be detected as induced voltages on a common read-out winding linking leg 3 of all transfluxors. (See Fig. 13.)

Coincident current selections for write-in and read-out are possible because there are thresholds below which pulses linking leg 1 and leg 3 produce negligible flux changes. Satisfactory operation is obtained with the prototype transfluxor when the selecting currents are approximately equal to the threshold values of setting and prime-drive shown on the characteristic of Fig. 7. Somewhat better results are found when the blocking write-in pulses are larger than the setting write-in pulses. The coincident current selection principle can be extended to the simultaneous addressing of many plane arrays used in parallel by using selective

inhibiting of the planes, as is customary with core memories.

Read-out from a magnetic storage device must necessarily be dynamic, since induced voltages are possible only by changing flux. Nevertheless, in the transfluxor memory, the read-out may be considered to be "nondestructive," because the flux in leg 1 is not altered by the interrogating pulses, retains at all time the stored information, and yet its value determines whether or not flux in legs 2 and 3 will be interchanged as a result of interrogation. The second interrogating pulse is necessary to restore the altered states of legs 2 and 3 due to the first, in a manner similar to the "rewrite" pulse in destructive read-out memories required when a read-out signal is obtained, but with the essential difference that its unconditional occurrence at every read-out is not dependent on the presence of the read-out signal.

In the transfluxor coincident current memory the read-out circuits are very simple since no feed back into the write-in circuits are required. A further, perhaps more important advantage, is the possibility of simultaneously writing-in and reading-out on two unrelated addresses, by energizing the proper lines of the independent write-in and read-out selecting grids. This possibility may speed up the operation and simplify the logic of some types of computing machines.

#### Channel Selector

Transfluxors may be used with advantage to select one channel out of many for transmission of modulated signals. The transmission from (or to) a common channel to (or from) each one of a number of selectable channels is controlled by a transfluxor. All transfluxors are blocked except one which is set and which determines the selected channel.

A channel selector for selecting one out of  $N=2^n$  channels in response to  $n$  binary pulsed signals is illustrated on Fig. 14 for the case of eight channels and three binary inputs. The selection system is similar to that used in combinatorial decoding switches<sup>3</sup> using conventional cores. For each binary input there is a pair of conductors, one of which links leg 1 of half the transfluxors and the other, the other half. The division of transfluxors in halves by the various input pairs is by juxtaposed halves, interlaced quarters, interlaced eighths, etc. so that the pattern of linkages is according to a binary code. To select a channel, current is sent through one or the other conductor in each pair in a direction tending to block the transfluxors which are linked by these conductors. For every combination of inputs

<sup>3</sup> J. A. Rajchman, "Static magnetic matrix memory and switching circuits," *RCA Rev.*, vol. 13, pp. 183-201; June, 1952. The binary decoding switches are described on pp. 188 and 189 under the name "Commutator Switches."

there will be one transfluxor, and one only, which is not linked by conductors carrying the blocking currents. The transfluxor, thus selected, is set by a current pulse sent through a winding which links leg 2 of all transfluxors. The setting pulse, occurring while the selecting current pulses are on, has insufficient amplitude to overcome the blocking effect of even a single one of these blocking currents and therefore sets the selected noninhibited transfluxor only. The setting is to maximum, but there is no danger of oversetting, since leg 2 is used for setting and the region of flux change during selection is around the large aperture only. The selected transfluxor remains set until a different combination of input pulses is applied to the selector, at which time a new transfluxor is set and the previously selected one is automatically blocked.

value producing spurious unblocking. In the prototype transfluxor the permissible range is from 0.25 to 1 AT. With asymmetric primary excitation a greater efficiency of power transmission is possible, as was explained. In this case it may be convenient to prime the transfluxor by a common winding linking leg 2 of all units (not shown on Fig. 14), to use a fixed amplitude prime pulse (1 AT for the prototype) and to modulate by the amplitude of the drive pulse.

The selector of Fig. 14 is shown with tube drivers to fully illustrate a concrete example. For simplicity, single turn windings are shown. Fig. 14b is a simplified representation of the selector, shown conventionally on Fig. 14a. The apertures of the transfluxors are represented by heavy horizontal lines which are assumed to be linked through by the vertical conductors when a 45° line is drawn at the intersection, the direction of inclination of the line denoting the direction of linkage.

It is possible to use the channel selector not only to gate sustained modulated signals, but also to control the amplitude of the transmitted signal in the selected channel according to the amplitude of a single control current pulse. To accomplish this, the control pulse is sent through the set winding linking leg 2 of all transfluxors simultaneously with the selecting pulses and sets the noninhibited selected transfluxor to a particular level in a continuous range dictated by its amplitude. Constant amplitude energization of the output circuits of all transfluxors produces through the selected one a sustained output of an amplitude determined by this level. The energization can be symmetric or asymmetric, ac or by pulses.

The arbitrary selection in any desired order of the transmission channel in the channel selector described earlier is accomplished by considering the large aperture of the transfluxor as if it were a simple core and linking it through systems of selecting windings known in conventional core decoding switches. Similarly, a commutator switch for establishing transmission through the channels in ordered succession can be made by coupling the large aperture of successive transfluxors by the circuits used in conventional magnetic shift registers. In the core switches the selected core produces a transient output at the instant of selection only, while in the analogous transfluxor switches the selected transfluxor opens for as long as desired a channel for bidirectional transmission of ac or pulsed signals.

Such channel selector switches for routing modulated signals either in an order depending on a code or else in a predetermined succession can be useful in a variety of applications, for example: multiplexing system for telegraphy or telephony communications; multiplexing for telemetering or automatic controls; switching of heads of a magnetic drum; central exchange in large systems handling digital information; telephone exchange systems, etc.

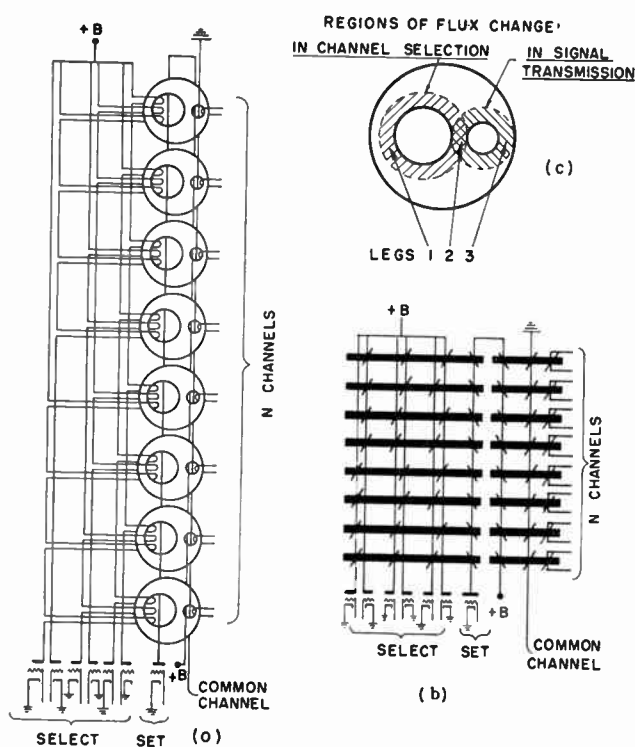

Fig. 14—Transfluxor channel selector.

Flux changes around the small aperture are possible only in the selected unblocked transfluxor of which the output magnetic circuit may be considered to be a regular transformer. Since a transformer transmits in either direction, the selector can be used either to transmit from the common channel to a selected channel or vice-versa, depending on which channel corresponds to the primary winding. The primary winding can be energized by symmetric ac current, provided that the resulting magnetization around the small aperture exceeds a certain threshold, but does not exceed a

Other Applications

In digital computers, in addition to its use as a gate with stored command mentioned before, the transfluxor can be used as a logical element as well as an auxiliary to energize incandescent lights to provide bright visual indicators with negligible loading on the pulse circuits.

The transfluxor is inherently an indicator of the peak pulse in an arbitrarily long pulse train. This property can be useful in nuclear instruments, for example.

In pulse modulation systems, in addition to channel selection, the transfluxor can convert pulse into amplitude information or convert randomly occurring pulses into regularly spaced pulses.

The control of automatic mechanisms by single command pulses, often a prerequisite for automation systems operated from a central computer, may easily be obtained with transfluxors.

These examples are cited to illustrate the variety of applications of the transfluxor.

MULTIAPERTURED TRANSFLUXORS

The two-aperture transfluxor has been discussed in detail to illustrate the principles of operation and the general properties of the device in one of its simplest forms. The use of over two apertures creates many new modes of flux transfer and broadens the kind and number of switching and storing functions, making possible many novel applications. A few illustrative examples of multiaperture transfluxors are described below.

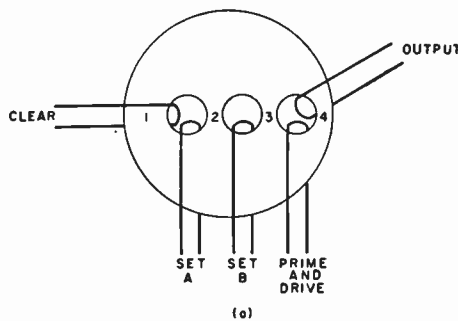

Fig. 15—Three-aperture transfluxor sequential gate.

A transfluxor with three apertures in a row, as shown in Fig. 15, can be operated as a two-input sequential gate. An output is produced if the two inputs *A* and *B* are applied to it in the order *AB* and no output is pro-

duced if either input is missing or if the two inputs are applied in the order *BA*. The operation is illustrated by the symbolic diagrams, Fig. 15b, 15c, and 15d. After a clear pulse the legs 2, 3, and 4 are saturated downward. The output flux path around the last aperture via legs 3 and 4 is blocked and neither the prime nor the drive pulse can produce any flux change. The flux path around the second aperture via legs 2 and 3 is also blocked so that the signal *B* cannot produce any flux change. However, the flux path around the first aperture, via legs 1 and 2, is not blocked and the signal *A* can reverse the direction of flux in leg 2 by transfer of flux to leg 1. If *A* was present and leg 2 was reversed, the flux path via legs 2 and 3 is unblocked, with the result that the occurrence of *B* can now reverse the flux of legs 2 and 3. This returns leg 2 to its original downward direction, reverses leg 3 and unblocks the flux path via legs 3 and 4. Consequently the output flux path is now unblocked and a succession of priming and driving pulses will produce an output for as long as desired. This three-apertured transfluxor can also be operated with intermediate setting. The analog intelligence can be carried by either signal *A* or *B* or both.

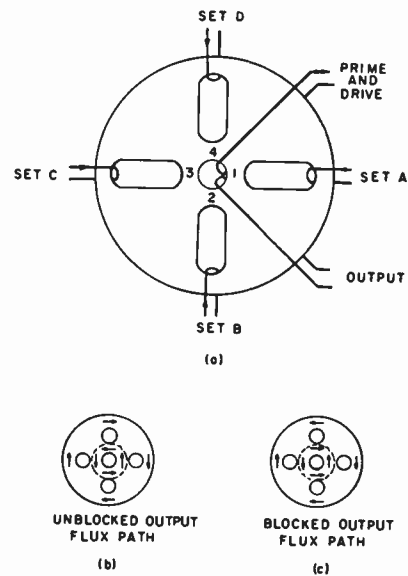

Fig. 16—Five-aperture "flower" transfluxor.

The transfluxor with five apertures arranged like a "flower," Fig. 16, can be operated as a four input "and" gate. The occurrence, in any order, of all four input signals *A*, *B*, *C*, and *D* is required to open the gate. The principle of operation depends upon the fact that the output flux via legs 1, 2, 3, and 4 around central aperture can be blocked by any one of the four legs and is unblocked only when the senses of flux saturation around central hole in all legs are the same. There are two unblocked states corresponding to two senses of flux rota-

tion around small aperture. In many applications it is convenient to use one leg as a reference (yielding a 3 input gate) and eliminate one of these states.

A third aperture added to the two of the transfluxor described earlier in detail can eliminate any possibility of oversetting. The four legs 1, 2, 3, and 4 of the transfluxor illustrated in Fig. 17 are of equal cross-section.

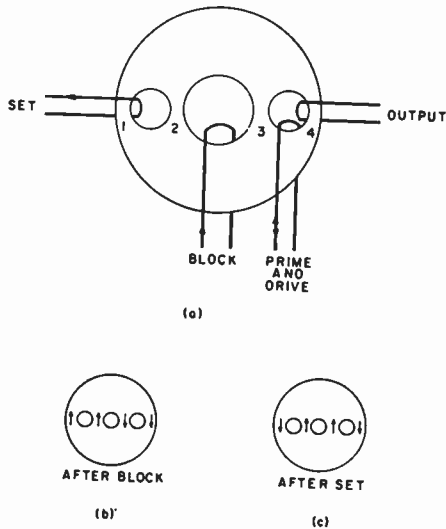

Fig. 17—Elimination of oversetting with an additional aperture.

The amount of flux that can be set is limited by the width of leg 1 to precisely the amount which leg 3 can accept. Therefore, when the setting pulse on leg 1 becomes larger than required to transfer flux to the first-filled closer leg 3, no further flux is available for transfer to leg 4. In this four-legged transfluxor leg 2 is a dummy which remains always saturated in the same direction and provides the necessary return path to satisfy continuity of flux flow.

A transfluxor which can be set by either polarity of setting pulse can be obtained by using four apertures, as shown in Fig. 18. It is apparent that either a positive or a negative set pulse will cause leg 5 to reverse its flux. For a positive set pulse this will occur with corresponding reversals of legs 2 and 4, and for a negative set pulse with reversals of legs 1 and 3. The output flux path via legs 5 and 6 is unblocked by the setting of leg 5. Blocking can also be of either polarity.

CONCLUSION

The transfluxor has the unique property of being able to control the transmission of electrical power according to a stored level established by a setting pulse. In contrast to the magnetic amplifier in which the in-

put command is not stored and must be present at all times, the transfluxor requires only a single setting. In contrast to the conventional memory core, the transfluxor is not only capable of storing a given amount of set-in flux, but also is capable of furnishing on demand, and for an indefinite length of time an output according to the stored setting without affecting that setting in the least. In a sense, the transfluxor combines the functions of a magnetic amplifier and a memory core.

The multiapertured transfluxor core, made of square hysteresis loop material used at present for ringed-shaped cores, is simple to manufacture. Like other magnetic elements it is a solid-state passive element which is rugged, stable in operation and immune to permanent deterioration due to accidental overdriving of its associated circuits.

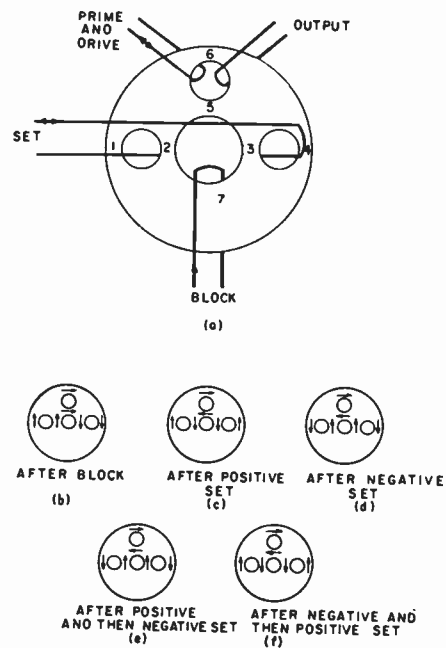
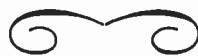

Fig. 18—Setting with a pulse of either polarity.

For these reasons it is believed that there is a great future for the transfluxors described in this paper and similar ones that can be made with artifices based on manipulating the flux distribution in cores of square loop magnetic material having a number of apertures in various geometrical configurations.

ACKNOWLEDGMENT

George R. Briggs has greatly contributed to the understanding of the operation of the transfluxor and helped in many experimental phases of the work.





# The O-Type Carcinotron Tube\*

P. PALLUEL† AND A. K. GOLDBERGER‡

**Summary**—This paper is devoted to O-type Carcinotron tubes, which are backward wave oscillators particularly suitable in applications requiring a tube with a very wide electronic tuning range and moderate power output.

A survey of backward-wave operation is given. Theoretical results on the starting conditions are shown to compare favorably with experimental values. The effects of reflections are discussed and are shown to be very small only when the delay line has properly matched terminals. Approximate expressions for efficiency and frequency-pushing are derived.

Design and performance data are given for a series of tubes now in production, each of which covers about one octave in frequency, providing total frequency coverage from 1,000 to 12,000 mc. The maximum beam voltage of any of the tubes in the series is 1,500 volts. The rf power output of the series is 100 to 1,000 milliwatts. Data on delay lines, gun structures and focusing are given, and results of tests on 100 tubes are tabulated.

## I. INTRODUCTION

**O**-TYPE Carcinotron<sup>1</sup> tubes are backward-wave oscillators characterized mainly by the following features:

1) An electron beam transfers energy along a delay line to a wave traveling in a direction opposite to the direction of the beam. Oscillation takes place if a certain synchronism condition between beam and phase velocities is fulfilled.

2) The operation is of the "electronic-coupling" type and is best achieved when no reflections exist at the line terminals.

3) The gun end of the line is connected to the external load; the collector end is matched to a load preferably inside of the tube.

4) The phase characteristic of the line is inherently dispersive, thereby permitting electronic-tuning over a very wide range by varying the accelerating voltage of the beam.

The "M-Carcinotron," described in detail in [1], also has the same general characteristics. However, the M-type tube has crossed electric and magnetic fields in the interaction space, both fields being essential to the operation of the tube; in the O-Carcinotron, the sole purpose of the axial magnetic field is to focus the electrons as they move in an equipotential region. Therefore, in the O-Carcinotron the electrons give up energy to the wave at the expense of their kinetic energy, whereas in the M-Carcinotron the electrons maintain a constant velocity but lose potential energy as they move from the sole to the line.

The earliest results on backward-wave tubes were given independently by R. Kompfner and B. Epsztein

at the Ottawa Conference in 1952 [2]. The parasitic oscillations observed in the Millman amplifier [3] were ascribed to the backward-wave-effect. Detailed results have been subsequently given by R. Kompfner, N. T. Williams [4], R. Warnecke, P. Guenard, O. Doehler, B. Epsztein [5]–[9], L. R. Walker [10], J. R. Pierce [11].

The present paper deals with a description of the work carried out on O-Carcinotrons at the Compagnie Générale de Télégraphie Sans Fil. The theoretical foundations of this work may be found in [9], a paper on traveling-wave tube phenomena in general. It is shown in the present article that the results of H. Heffner [12] agree with those of [9] except for notation, but a more complete description of the starting conditions is given here by taking into account the effects of terminal reflections and load mismatch which play an important role in practical applications. The introduction of reflections in the calculations is carried out in the Appendix and their effect is discussed on the basis of an unpublished work of P. Guenard and C. Berterottiere [13].

Experimental results and design data are given for broad-band standard production tubes in the range 1,000 to 12,000 mc. Comparison is made with theory for starting conditions and small-signal behavior.

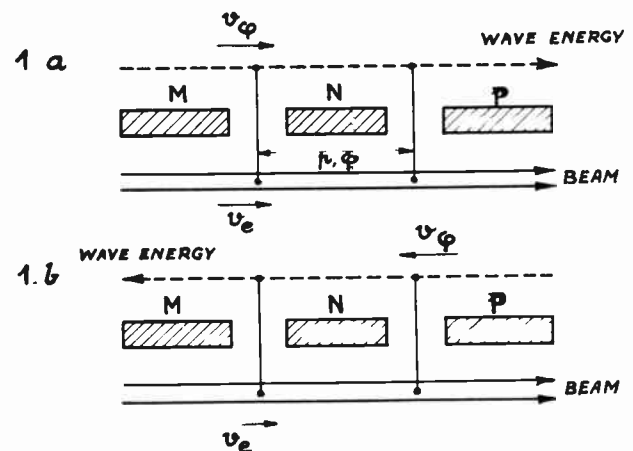

Fig. 1—Relative propagation of electron beam and wave: (a) in traveling wave amplifiers (b) in Carcinotrons.

## II. QUALITATIVE ANALYSIS OF THE OSCILLATION PROCESS AND STARTING CONDITIONS

Let us consider a delay line along which an electron-beam may interact with waves at equidistant points  $M$ ,  $N$ , etc., whose spacing is the pitch  $p$  (Fig. 1). The phase shift  $\phi$  between  $M$  and  $N$  is assumed to be smaller than  $\pi$  and the corresponding fundamental phase velocity  $v_\phi$  is assumed to have the same direction as the energy propagation.

\* Original manuscript received by the IRE, June 6, 1955; revised manuscript received, November 10, 1955.

† Compagnie Générale de TSF, Paris, France.

‡ American Radio Company, 445 Park Ave., New York, N. Y.

<sup>1</sup> Registered trade mark of the Compagnie Générale de TSF.

In usual traveling-wave amplifiers the wave grows in the beam direction  $MN$  when

$$\frac{c}{v_e} - \frac{c}{v_\phi} = m \cdot \frac{\lambda}{p}, \tag{1a}$$

where  $v_e$  is the beam velocity,  $\lambda$  is the free space wavelength and  $m$  is an integer.

For backward interaction a growing wave in the opposite direction  $NM$  occurs when

$$\frac{c}{v_e} + \frac{c}{v_\phi} = m \cdot \frac{\lambda}{p}. \tag{1b}$$

$m=0$  in (1a) is the well known synchronism condition for optimum gain in traveling-wave tubes.  $m \neq 0$  means that the beam travels more slowly than the phase of the fundamental mode. The synchronism condition is fulfilled for values of  $v_\phi$  corresponding to the so called "space-harmonics."

Under the initial assumptions,  $m=0$  has no significance in Carcinotron tubes and interaction occurs only with space harmonics, which, as shown in Fig. 2, lie between those of traveling-wave amplifier operation. They have opposite phase and group velocities. For a line with a fundamental phase velocity in the opposite direction of the energy propagation,  $m=0$  corresponds to a Carcinotron tube.

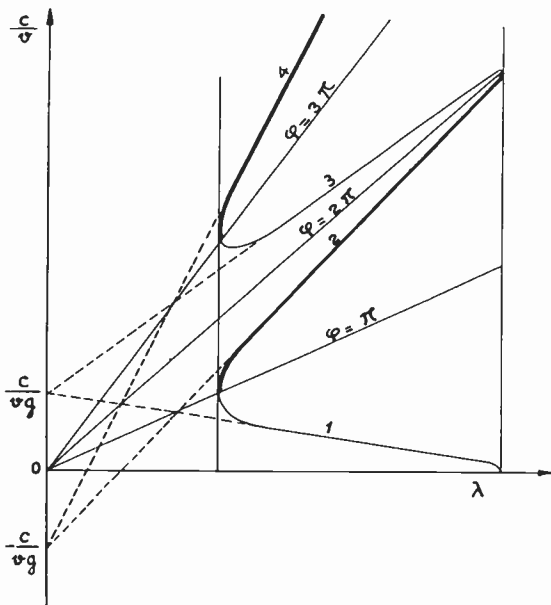

Fig. 2—Space harmonics of a delay line. Phase and energy velocity have opposite signs for modes 2-4.

The space harmonics have no individual existence as waves, but result from the analysis of the nonsinusoidal form of the field due to the geometrical singularities introduced by the periodic elements of the line. They are high mode field components confined to the vicinity of these elements and vanish rapidly with distance from the line and with increase of  $m$ . The strength of the coupling between beam and wave depends, therefore:

- 1) On what part of the total energy can be assigned to a particular space-harmonic according to the dimensions of the line elements, and
- 2) On the position of the beam with respect to the line.

A qualitative description of the starting conditions of oscillation can now be given in very simplified form. When the beam travels from the 0 or gun end to the  $l$  or collector end of the tube, the wave energy resulting from interaction at any point  $z$  gives rise to two equal components. The first one travels towards the  $l$ -end where all similar components cancel. The second grows in the reverse direction and is maximum at the 0-end where it modulates the beam.

The build-up of oscillations takes place when the beam current reaches a proper level. The value  $I_s$  of this "starting current" is related to the magnitude of the interaction effect, that is to the "gain" in usual terms along the line,  $\gamma_0 l$ . A minimum value of  $\gamma_0 l$  is required in order to supply the power delivered by the delay line to the output circuit. In calculations, the backward-wave effect is analogous to positive feedback, involving negative coupling impedance as in conventional oscillators.

It can be shown that the interaction modifies slightly the synchronism condition (1b). Therefore the starting frequency condition is:

$$(\Gamma_0 - \Gamma_e)l = (2m + 1)\pi, \tag{2}$$

where  $\Gamma_0$  is the constant of propagation corresponding to the phase velocity and  $\Gamma_e = \omega/v_e$ .

The presence of the integer  $m$  in (2) allows a multitude of frequencies. This implies an additional phase difference  $2m\pi\rho/l$  apart from the optimal synchronism condition between adjacent elements of the line. A higher value of the starting current is thus required for any  $m \neq 0$  mode.

The effect of space charge may be interpreted as a phase lag in the beam, which leads to a decrease in frequency and an increase in starting current. This effect can be translated into proper values of the second term of (2) where it can become preponderant under very large space charge conditions.

Reflections due to mismatches at the line terminals also disturb the starting conditions. No effect occurs when an end is perfectly matched, and the product of end reflections must be taken into account by the quantity  $\rho = |\rho_i| \cdot e^{i\psi}$  where  $|\rho| = |\tau_0| \cdot |\tau_i|$  is the product of end reflections coefficients and  $\psi = 2\Gamma_0 l + \psi_0 + 4i$  is the internal phase shift of reflected signals.

For small reflection and  $\psi = k\pi$  the effect is similar to positive or negative feedback and results in lower or higher starting currents without a change of starting frequency  $F_s$ . For  $\psi = (2k+1)\pi/2$  a small change in frequency results from modification of phase condition.

A large reflected signal can no longer be considered as a separate component and must be taken into account in the interaction in order to obtain the relation of  $I_s$  and  $F_s$  with  $|\rho|$  and  $\psi$ .

III. THEORETICAL RESULTS FOR THE STARTING CONDITIONS

The process of introducing reflections in setting up the equations for interaction will be described in the Appendix.

The calculation of starting conditions [9] [13] leads to the equation

$$(e^{-jx_1\Lambda} - \rho) \frac{x_2 - x_3}{x_1} + (e^{-jx_2\Lambda} - \rho) \frac{x_3 - x_1}{x_2} + (e^{-jx_3\Lambda} - \rho) \frac{x_1 - x_2}{x_3} = 0, \quad (3)$$

where  $x_1, x_2, x_3$  are the solutions of

$$x[(x + 2\zeta)^2 - k^2] = 1, \quad (4)$$

with the following definitions<sup>2</sup>

$$x = \frac{\Gamma - \Gamma_0}{\gamma_0}, \quad 2\zeta = \frac{\Gamma_0 - \Gamma_e}{\gamma_0}, \quad \Lambda = \gamma_0 l$$

$$\gamma_0 = \left( \Gamma_e \Gamma_0^2 \frac{R_c}{4R_0} \right)^{1/3}$$

$$k = \frac{\Omega_0 f}{v_e \gamma_0}$$

and notation:

$\Gamma$  = constant of propagation for the wave in interaction.

$\Gamma_0$  = constant of propagation for the free wave.

$\Gamma_e$  = the equivalent constant corresponding to the beam velocity.

$\Omega_0$  = the plasma frequency  $\Omega_0 = \sqrt{(e/m)(\rho_0/\epsilon_0)}$ .

$f(<1)$  = a factor taking into account the geometry of the beam [14].

$R_0$  = the beam impedance

$R_c$  = the coupling impedance.

In (3) and (4) for any value of  $\rho$  there corresponds values of  $\Lambda$  and  $2\zeta$ , which give, from above definitions, frequency, and current for the starting conditions

$$(\Gamma_0 - \Gamma_e)l = 2\zeta\Lambda \quad (5)$$

$$I_s = 4\Lambda^3 \frac{V_0}{\Gamma_0 \Gamma_e^2 R_c l^3} \quad (6)$$

Numerical Analysis of Starting Conditions

Eqs. (3) and (4) can be solved graphically as follows in the plane of  $\rho$ . For any value of  $2\zeta$  the curves  $\rho(\Lambda)$  are spirals starting vertically from  $\rho=1$ . They penetrate into the circle  $\rho < 1$  at successive turns giving the conditions for successive oscillations expected from Section II.

A more useful description is obtained with the parameters

<sup>2</sup> Heffner's [12] equations reduce to (3) and (4) for  $\rho=0$  with  $2\pi CN = \Lambda$ ,  $\theta = -2\zeta\Lambda$ ,  $H = k\Lambda$ ,  $\eta = -x\Lambda$ .

$$\Phi = 2\zeta\Lambda$$

$$S = 4\Lambda^3,$$

where  $\Phi$  defines the frequency-voltage characteristics and  $S$  is proportional to starting-current.

A complete pattern of  $\Phi$  and  $S$  is plotted on Fig. 3 for the first oscillation. Some values of the parameters for the second oscillation are shown on Fig. 4.

When reflections are negligible, the solutions correspond to the centers of the  $\rho$  circles and the values are found in Table I.

TABLE I

	$2\zeta$	$\Lambda$	$\Phi$	$S$
1st oscillation	1.52	1.98	3.01	31
2nd oscillation	2.77	3.65	10.11	195

The values of  $\Phi$  are close to  $\pi$  and  $3\pi$  as predicted by (2). The second oscillation starts for:

$$I_{s_2} = 6.3 I_{s_1}.$$

When  $\rho \neq 0$ ,  $\Phi$  and  $S$  are more or less altered according to the magnitude and phase of  $\rho$ .

As previously expected, maximum deviations of  $I_s$  and frequency  $F$  occur respectively at  $\psi = k\pi$  and  $\psi = (2k+1)\pi/2$  for small  $|\rho|$ . For large  $|\rho|$  the situation is more complicated but it is possible to derive from Fig. 3 and from approximate solutions of (3) and (4), good evaluations of  $\phi$  and  $S$  for  $|\rho|$  and  $\psi$  over a wide range of values.

Effect of Reflections on the Starting Current

From Fig. 3, max and min values of  $I_s$  are

$$I_s = I_{s_0}(1 + |\rho|) \quad \text{where } I_{s_0} \text{ is } I_s \text{ for } \rho = 0.$$

$$i_s = I_{s_0}(1 - |\rho|)$$

Ripples are therefore observed on the starting current/line voltage curve; from adjacent max and min of the curve an approximate value of  $|\rho|$  can be deduced:

$$|\rho| = \frac{I_s/i_s - 1}{I_s/i_s + 1}.$$

$I_s$  fluctuations on the second oscillation have the same aspect. From Fig. 5 it is seen that the ratio  $i_{s_2}/I_{s_1}$  decreases with increasing  $\rho$ . When  $\rho$  becomes close to 1, variations of the phase conditions allow for mode jumping, and the system behaves as a reactively coupled system. This effect results from  $\rho=1$  for  $\Lambda=0$  in (3) and (4).

Effect of Reflections on the Frequency Characteristic

Because of the variation of  $\Phi$  with  $\rho$ , the frequency changes according to

$$\Delta[(\Gamma_0 - \Gamma_e)l] = \Delta\Phi. \quad (7)$$

From Fig. 3,  $\Delta\phi_{\max} = \pm 2|\rho|$  for a wide range of  $\rho$ , so that the maximum relative variation of frequency,  $y = (F_\rho - F_0)/F_0$ , is

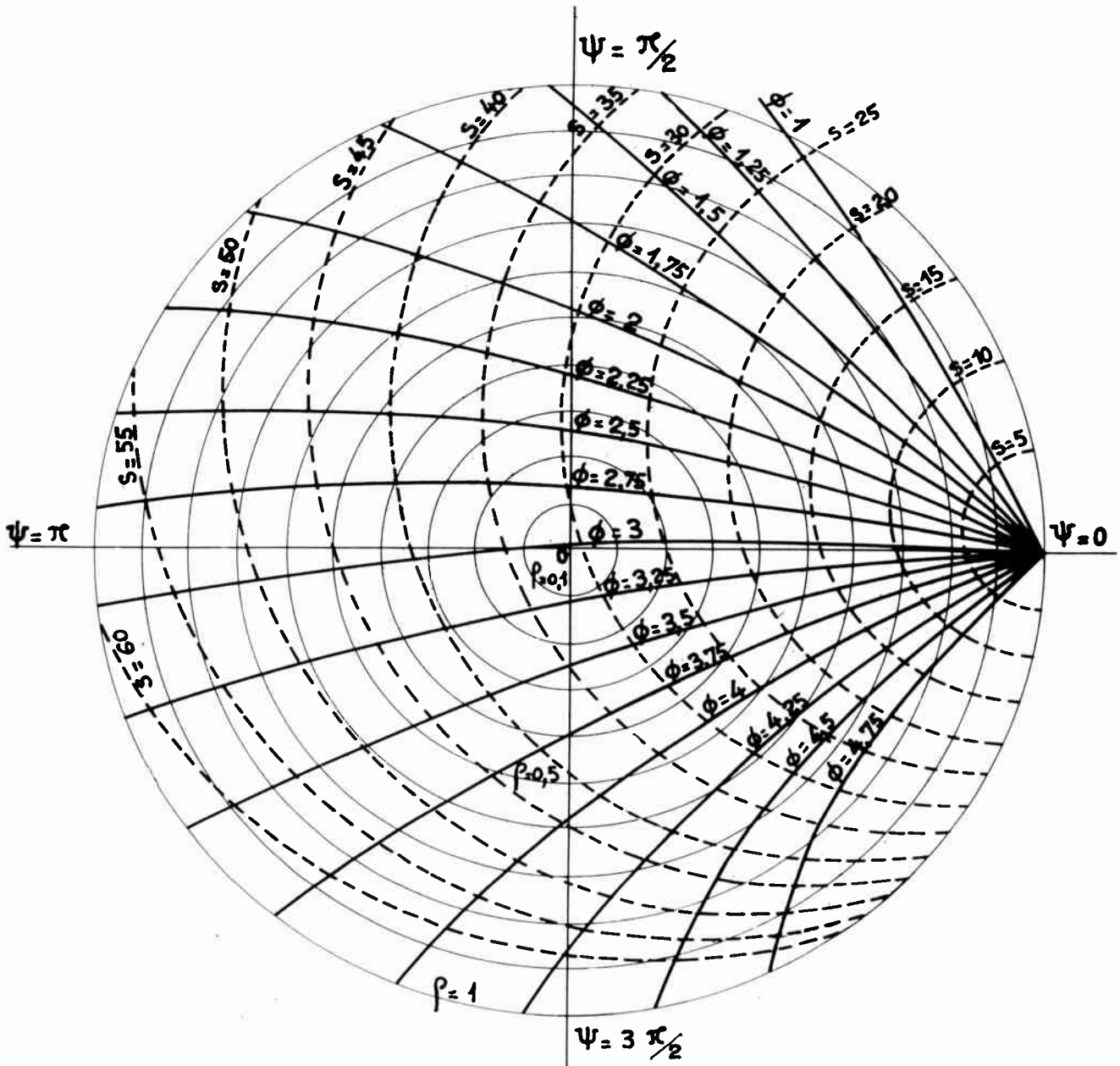

Fig. 3—Values of  $\Phi=2\zeta\Lambda$  and  $S=4\Lambda^2$  for the first oscillation. Variations of  $\phi$  and  $S$  with the position in the  $\rho$  circles gives the frequency and current for starting conditions.

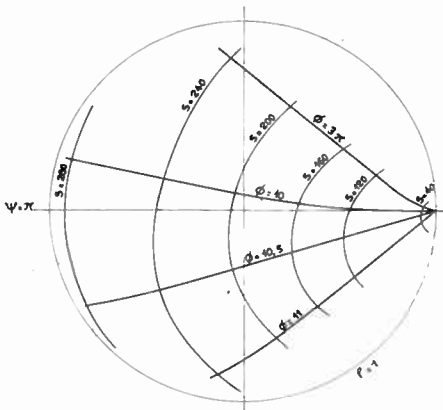

Fig. 4—Plot of  $\Phi$  and  $S$  for the second oscillation.

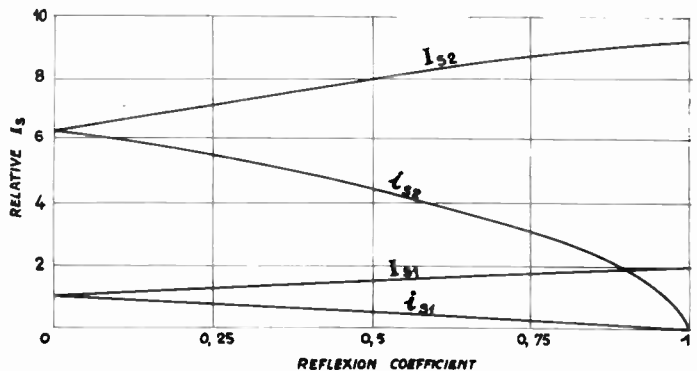

Fig. 5—Values of max and min starting currents for first oscillation ( $I_{s1}$ ,  $i_{s1}$ ) and second oscillation ( $I_{s2}$ ,  $i_{s2}$ ) as a function of the reflection coefficient. For unfavourable phase conditions  $I_{s1}$  is to be compared to  $i_{s2}$ .

$$(\Gamma_e + \Gamma_o)l \cdot y = \pm 2|\rho| \cdot \left( \Gamma_o = \frac{\omega}{v_o} \right) \quad (8)$$

When  $\psi = k\pi$  the frequency is about  $F_0$  for all  $\rho$  but has its maximum sensitivity with  $\psi$ .

On the other hand,  $\psi$  varies periodically according to

$$\Delta\psi = -2\Gamma_o l y. \quad (9)$$

The value of  $y$  for which  $\Delta\psi = 2\pi$  is usually small so that variations of  $\rho$  with frequency, owing to the load and terminals, can be neglected in such a range.

The slope  $\sigma = dF/dV$  of the frequency-voltage characteristic can be derived from (7) and (9). Since, from Fig. 3,

$$\left( \frac{\Delta\Phi}{\Delta\Psi} \right)_{\max} = \pm \frac{2|\rho|}{1 \mp |\rho|}, \quad (10)$$

the max and min of  $\sigma$  are

$$\sigma_m = \frac{1}{2} \frac{F}{V} \frac{\Gamma_e}{\Gamma_e + \Gamma_o \mp \frac{4|\rho|}{1 \pm |\rho|} \Gamma_o}, \quad (11)$$

whence the max relative variation of the slope for small  $\rho$  is

$$\frac{\Delta\sigma}{\sigma_0} = \pm 4|\rho| \cdot \frac{\Gamma_o}{\Gamma_e + \Gamma_o}. \quad (12)$$

A change in the sign of  $\sigma$  can occur when

$$|\rho| \geq \frac{\Gamma_e + \Gamma_o}{3\Gamma_o - \Gamma_e},$$

resulting in possible frequency discontinuity and hysteresis phenomena for large reflections. From (12) the frequency/voltage slope is very sensitive to small reflections.

When the reflections at the 0 and  $l$  ends are known, Fig. 3 can be translated into a Rieke diagram by taking into account the effect on  $\rho$  of the load reflection through the load connecting or output line.

#### Effect of Losses

Losses on the line reduce the reflection to  $\rho \cdot e^{-2A}$  where  $A$  is the total attenuation in nepers on the line.

From (5) with  $\Gamma_0 = \beta + j\alpha$ ,  $\Phi$  becomes  $\Phi + jA$  where  $A = \alpha l$ . The effect of  $jA$  results in an increase of  $I_s$  by a factor  $e^{A/2}$  when  $A$  is of the order of 1 or less. In this case the effect of reflection can become very small.

Losses of current along the line have also been evaluated by assuming a constant decrement of current [15]. This effect increases the starting current in the same way as a distributed attenuation. If  $\theta$  is the focusing efficiency (collector-current to gun-current), the rate of increase of the starting current is  $\theta^{-3/4}$ , equivalent to a  $A = 2\sqrt{3} \log 1/\theta$ . Evidently this term must not affect the value of  $\rho$ .

#### Effect of Space Charge

The value of the space-charge parameter  $k$  in (4) is

$$k = \frac{fl}{\Delta v_e} \sqrt{\frac{\rho_0}{m\epsilon_0}}.$$

It differs from the  $H$  used in other papers by the factor  $f/\Delta$ . Curves relating the variations of  $2\zeta$  and  $\Lambda$  with  $k$  and  $\rho$  have already been published [9]. Some values of resolving parameters are given vs  $k$  for  $\rho = 0$  in Table II. The space charge has a very small effect when  $k \leq 1$ . For  $k \geq 2$ ,  $\Phi$  and  $S$  become approximately  $k\Lambda$  and  $20k\Lambda$ .  $\Phi = 10.1$  and  $S = 195$  are obtained for same value of  $k$ , confirming the assumption made in Section II.

TABLE II

$k$	$2\zeta$	$\Lambda$	$\Phi$	$S$	$k\Lambda$
0	1.52	1.98	3.01	31	0
1	1.55	2.15	3.33	40	2.15
2	2.1	3.1	6.6	120	6.2
3	3.05	3.85	11.6	230	11.6

Under reflection conditions, fluctuations of  $I_s$  become relatively larger than for  $k = 0$ . Table III gives some values of  $I_s/i_s(|\rho| = 0.4)$ . It may be seen that a combination of reflections and space charge effects can give rise to frequency gaps or parasitic oscillations according to the phase of large  $\rho$ .

TABLE III

$k$	$\frac{I_s(\rho)}{I_{s_0}}$	$\frac{i_s(\rho)}{i_{s_0}}$	$\frac{I_s(\rho)}{i_s(\rho)}$
0	1.4	0.6	2.3
1	1.56	0.6	2.6
2	2	0.36	5.6
3	2.8	0.2	14

For an unfavorable phase of  $\rho$  the maximum variation of  $\Phi$  is of the order of  $2k|\rho|$  when  $k$  is large. The fluctuations of  $\sigma$  become larger and the limit of  $|\rho|$  for stability is correspondingly lowered.

#### IV. EXPERIMENTAL RESULTS

A very large amount of work has been carried out in the careful investigation of the characteristics and development of tubes designed for tuning-ranges extending over about one octave.

Before the description of practical data which are given in Section V, experimental results are first compared with theory. Tubes for the following ranges were investigated: 1,000–2,000 mc, 2,000–4,000 mc, 6,000–11,000 mc respectively termed L-band, S-band, and X-band tubes in the text.

#### Frequency-Voltage Characteristics

The frequency range originates from dispersion characteristics of line. All L-, S-, and X-band tubes have interdigital lines operating on first reverse mode, numerically estimated by simple geometrical considerations.

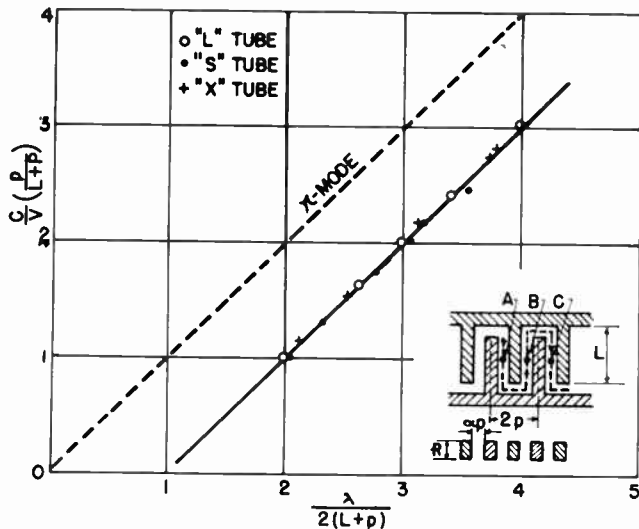

Fig. 6—Schematic drawing of the interdigital line and dispersion characteristics for *L*, *S*, and *X*-band tubes. The usual coordinates  $\lambda$ ,  $c/v$  are normalized into  $\lambda/2(L+p)$  and  $c/v$ .  $x(p/L+p)$ .

Referring to the schematic drawing of Fig. 6, the pitch *AC* of the system corresponds to a wave path  $2(L+p)$  instead of  $2p$  for the direct path, where *L* is the finger length and  $2p$  the pitch *AC*. From (1b) the synchronism condition is:

$$\frac{c}{v_e} + \frac{2(L+p)}{2p} = m \frac{\lambda}{2p}$$

The equation

$$\frac{c}{v_e} = \frac{\lambda - 2(L+p)}{2p}$$

expresses the synchronism condition for the desired mode  $m=1$ . Taking into account the reversal of phase  $\pi$  occurring from the change of the axial field direction between adjacent fingers, this mode appears as a fundamental reverse mode of the line of pitch *p*.

A very good agreement with the above relation is shown in Fig. 6 where experimental results for *L*-, *S*-, and *X*-band tubes are plotted in normalized coordinates.

The corresponding frequency-voltage characteristics are plotted on Fig. 7. The slope  $\sigma$  of these curves decreases continuously along the frequency range but may be assumed constant along a larger bandwidth than for klystrons because of the square law found here instead of a cubic law for klystrons.

At a wavelength  $\lambda=4L$ , a strong direct coupling between fingers of same direction can overcome and disturb frequency characteristic and coupling impedance. Such effect will be noted in starting current of *S*-band tubes.

**Starting Current**

From (6), under the assumption of zero space charge, loss and reflection, the starting current is

$$I_s = \frac{31V}{\Gamma_0^3 R_c}$$

Here  $R_c$  is the coupling impedance

$$R_c = \frac{Z_0}{\Gamma_0^2 p^2} \cdot \frac{\alpha p}{h} \left[ \frac{\sin\left(\frac{\Gamma_0 \alpha p}{2}\right)}{\frac{\Gamma_0 \alpha p}{2}} \right]^2 \cdot \frac{1}{K}$$

where  $Z_0$  is the characteristic impedance of the line,  $\alpha p$  and *h* the dimensions shown on Fig. 6. *K* is a dimensionless parameter resulting from the shape of the beam and its position with respect to the line. *K* is derived in the same way as the well-known corresponding factor for helices and cylindrical beams. It can be approximated for a flat beam close to the line as  $K=4\Gamma_0 d \cdot e^{2\Gamma_0(d-a)}$  where  $2a$  is the beam thickness and *d* the distance from the line to the median plane of the beam.

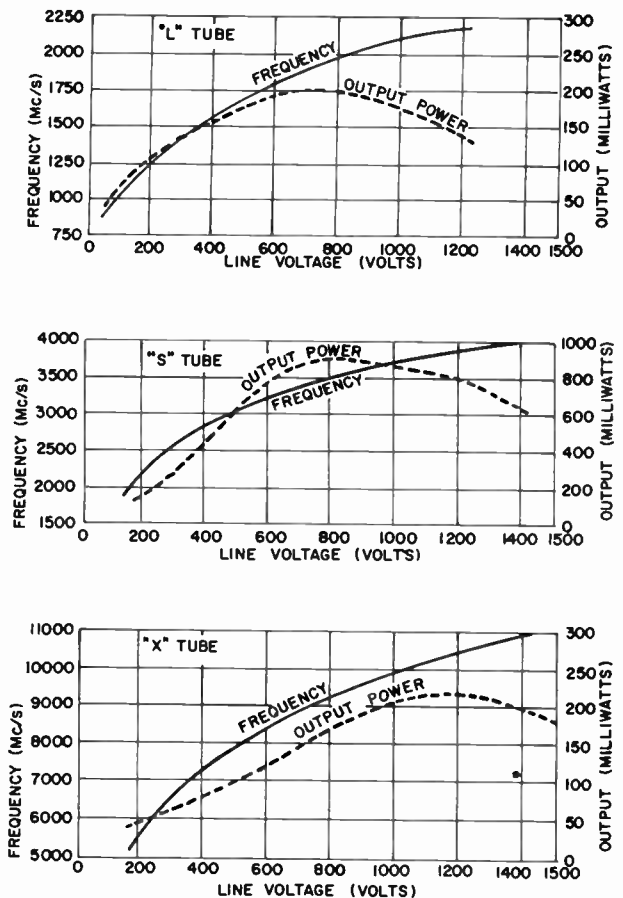

Fig. 7—Frequency and rf power versus line voltage for *L*, *S*, and *X*-band tubes. Power plots are average values.

Computed and experimental values of the starting currents are plotted on Fig. 8 for *S*-band and *X*-band tubes with satisfactory agreement. The high voltage peak found for the *S*-band tube is ascribed to the mentioned effect for  $\lambda=4L$ .

It can be expected from above results that the space charge effect is probably small except perhaps at low voltage. The higher values of *k* occur at low frequencies and are of the order of 1 for both tubes resulting in an increase of  $I_s$  by a factor of 4/3.

In Fig. 8 are plotted the working currents  $I$ . The ratio  $I/I_s$  is such that the tubes operate well below the critical conditions for parasitic oscillation.

*Effect of Reflections*

As previously pointed out the fluctuations of the starting current may be roughly translated into an equivalent standing-wave ratio, thereby permitting an estimation of  $|\rho|$ .

It follows from results such as given in Fig. 8 that only small reflection effects occur in such tubes owing to their proper matching. The corresponding fluctuations

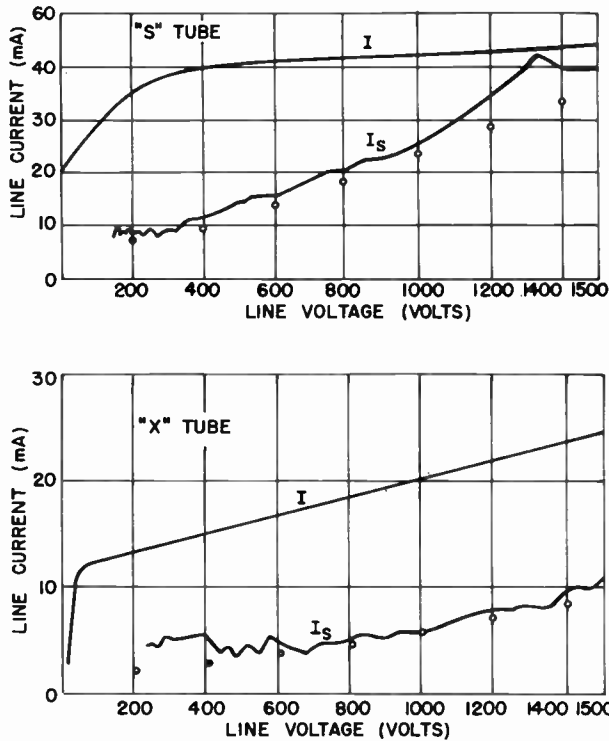

Fig. 8—Starting current and working current of S- and X-band tubes. Separate points are theoretical values of starting current.

of the frequency sensitivity for the same S tube are plotted in Fig. 9 and may be roughly related to the  $I_s$  fluctuations.

*Output Power, Efficiency, Frequency Pushing*

Values of rf power are also plotted (Fig. 7) as average values for a number of tubes of each type. The shape of individual power curves depends on the method of measurement. Optimum power values are obtained by proper matching of the power meter at every frequency. Plots checked from standard loads show fluctuations according to mismatch. An example of such a plot made by using a self-balanced thermistor bridge is given in Fig. 10 for an X-band tube.

The rf power can be controlled by changing the voltage of one electrode of the gun. The response is linear over a wide range of controlling voltage, allowing amplitude modulation.

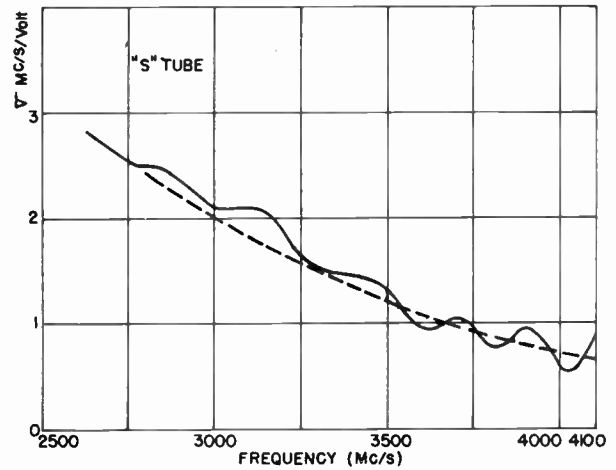

Fig. 9—Sensitivity  $\sigma = dF/dV$  versus frequency for an S-band tube showing the effect of small reflections. Dotted curve is the theoretical sensitivity.

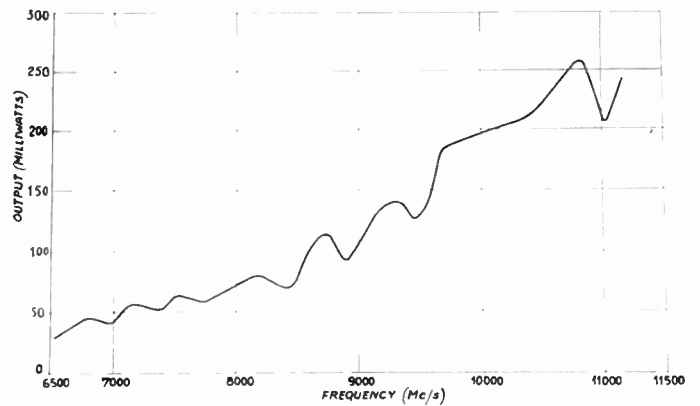

Fig. 10—The rf power curve for a x-band tube measured through a standard matched load.

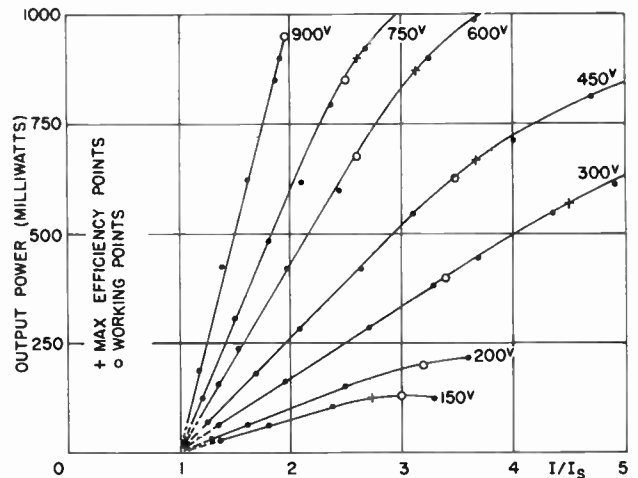

Fig. 11—Variation of rf power with the ratio of the beam current to the starting current for an S-band tube. Plots for several values of line-voltage.

Fig. 11 is a plot of variations of the rf power with the beam current for several voltages. Straight characteristics run almost up to the working current which is chosen close to the point of maximum efficiency.

The slope of such characteristics expresses the incremental power variation with the current. The ratio  $\eta = \Delta W / v \cdot \Delta I$  of corresponding rf and dc power variations can be defined from the linear experimental law as an "interaction efficiency."

Let us return to discussion of the starting conditions for an estimation of the interaction efficiency.

An increase  $\Delta I$  of the current results in an increase of rf power  $\Delta W$  and in a loss of beam velocity which in turn involves, according to the synchronism condition, a decrease of frequency  $\Delta F$ .

From the energy balance and starting equations are found compatible values of interaction efficiency and frequency-pushing:

$$\eta \approx \frac{4}{L\Gamma_e} = \left( \frac{2R_c}{V/I_s} \right)^{1/3} \quad (13)$$

$$\frac{dF}{dI} = - \frac{\sigma\eta V}{2I} \quad (14)$$

These expressions assume the validity of small signal conditions beyond the starting point, which can be done because of the low efficiency of the O-carcinotron. Experimental results confirm this assumption.

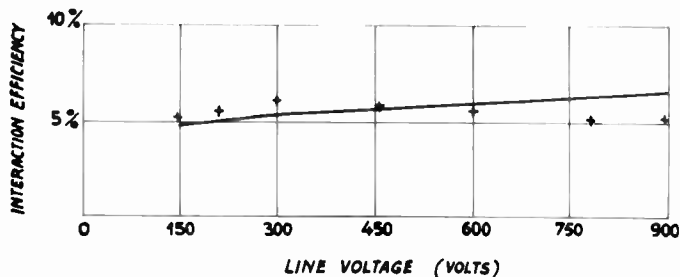

Fig. 12—Interaction efficiency. The continuous curve is the estimated value. Separate points are the ratios of the slope of the characteristics shown in Fig. 11 to the voltage.

A plot of experimental and theoretical values of  $\eta$  for an S tube is given Fig. 12. In Fig. 13 are plotted experimental frequency-pushing characteristics in comparison with values of

$$F_1 = F_{1s} - \frac{\sigma\eta V}{2} \ln I/I_s.$$

Experimental and theoretical results are comparable.

From (13) follows the influence on  $\eta$  of the coupling impedance  $R_c$  and beam impedance  $V/I_s$ , which can be taken into account in the design of tubes. From

$$\frac{dF}{dI} = - \frac{\sigma}{2} (2R_c)^{1/3} \left( \frac{V}{I} \right)^{2/3}$$

for the frequency pushing it is seen that relatively large efficiency and small pushing-effect are compatible.

V. DESIGN OF O-CARCINOTRONS AND PRACTICAL DATA

We shall now be concerned with the general description of the Carcinotron design with special attention being given to very broad-band tuning. As an illustration of practical solutions, some data is given for several types of standard production tubes.

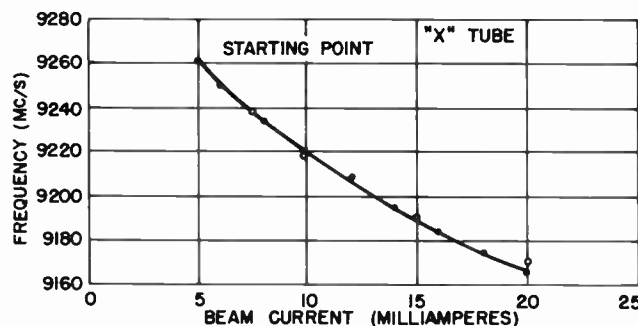
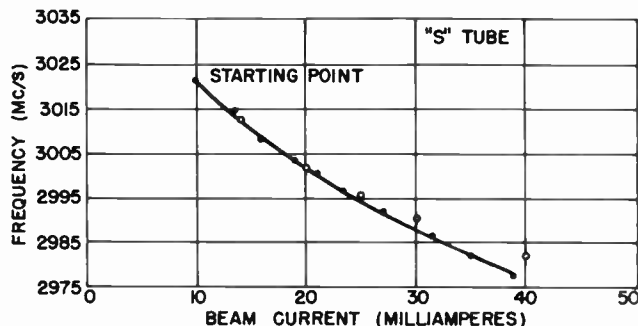

Fig. 13—Plots of frequency-pushing versus beam-current for S- and X-band tubes. Separate points are calculated values.

Broad-Band Design

The most important features for very broad-band design can be summarized as follows:

The type of delay line and the dimensions must allow a large frequency variation within a reasonable corresponding voltage range and provide an appropriate broad-band matching to usual standard loads.

A proper ratio must be maintained along whole range between working and starting currents. Proper reciprocal adjustment of parameters such as dimensions of line, coupling impedance and gun characteristics must be made, taking into account desired level of rf power.

Best results are achieved when line and load impedances are not very different, interaction length is short, and critical focusing is avoided within the voltage range.

As shown later, beam-tetrode guns give better ratios of working to starting current than triode guns.

Uniform magnetic focusing of beams by means of coils or permanent magnets is most commonly used. Recently theoretical possibilities of focusing by means of periodic magnetic and electrostatic fields were stated [16] [17] [18]. Some experimental results are given by Tien [19] and in this paper.



Different types of delay lines may be used. Helices of the usual type are easily constructed and matched, but must be long because of their low thermal dissipation and because of operation on a space harmonic. These disadvantages are only partly overcome by using special arrangements such as ribbon-shaped wires, flat winding or bifilar systems, but interesting experimental results were obtained with systems of particular design [20].

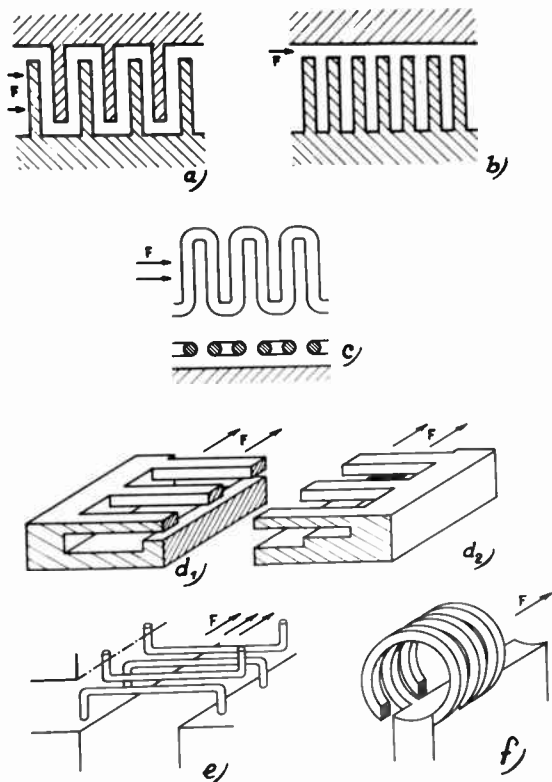

Fig. 14—Sketches of various forms of delay lines. Interdigital lines: flat (a) and cylindrical (f); vane line (b); meander line (c); ladder lines ( $d_1$  and  $d_2$ ); rising sun ladder line (e).  $F$  represents the beam.

Among the most useful systems, typical forms are shown in Fig. 14. They are all made by combinations of periodical elements of various shapes: fingers, rods, vanes, ladders, etc. [21]–[25]. General methods were derived for computation of dispersion characteristic, impedance and matching of various systems [26]–[29].

Some lines have a fundamental reverse mode, such as interdigital lines, ladder systems with a proper shaped sole, strapped or rising sun vanes derived from magnetron circuits. Others operate on a space harmonic with the disadvantage that their coupling impedance is lower.

Construction problems limit the usefulness of these lines in the high-frequency spectrum. All the above-mentioned lines are easily fabricated up to the short centimeter range, but in the millimeter range difficulties are soon encountered so that published results are very often obtained from laboratory devices only.

Space harmonic operation extends the frequency limit but difficulties of construction predominate. There are

now good grounds for thinking that industrial construction and satisfactory performance will be made possible by a proper choice of lines and construction process. An illustration of present possibilities in the millimeter range is described by A. Karp [30] for a “slotted-wall” system similar to the “ladder” line of Fig. 11.

#### Technical Data on O-Carcinotrons

The experimental results reported in the previous section were obtained from tubes which will now be described from a more technical point of view. They are typical models of a group of tubes which have been

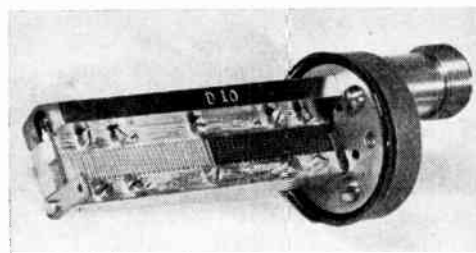

Fig. 15—Photograph of the inside of the line assembly of a X-band tube showing the interdigital line with its internal load and its connection to the coaxial output.

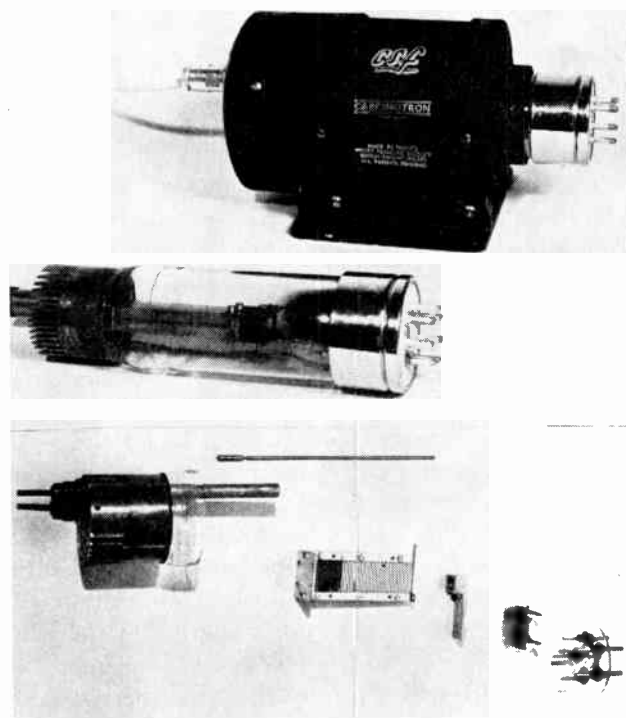

Fig. 16—Tube CO 119: Components of the line, tube, and mounting.

listed in another paper [31]. Each model has a continuous tuning range of about one octave, and the series covers the range from 900 mc up to 15,000 mc with overlaps in the most used frequency allocations.

*Lines.* Interdigital lines are used throughout in these models. Most of them are flat as shown in Figs. 15 and 16

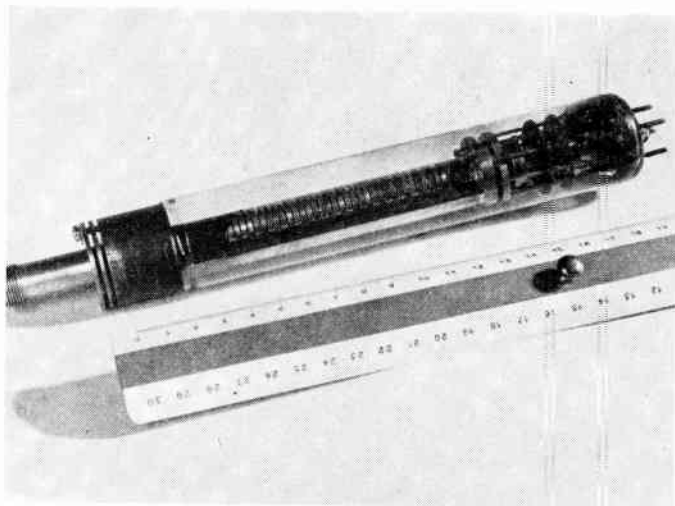

Fig. 17—Photograph of a *L* tube showing the circular interdigital line.

for X- and S-band tubes. At low frequencies, tubes with a cylindrical arrangement of the line as in the *L*-band tube (Fig. 17), have smaller cross-sectional dimensions.

Finger dimension examples are given by Table IV below, with corresponding frequency and voltage ranges:

At the collector end, a number of fingers are coated with a deposit of absorbing material, such as magnetic alloy, or aquadag on a mica sheet, forming a matched load. The first finger at the gun end is connected to the internal conductor of a coaxial line which is terminated through a glass-seal by a standard coaxial *N*-jack. For convenience rf output is at end of tube opposite socket.

The matching of the line to a standard impedance of 50 ohms is accomplished by proper construction and minor adjustment of the position of the first finger. Typical matching curves are plotted in Fig. 18.

**Guns.** The guns are of the beam tetrode type. Their main advantage can be understood from Fig. 19 where curves are plotted of starting current in comparison with triode and tetrode characteristics. For a triode gun, large power output can be obtained at high voltage, but large rf power variation occurs over the tuning range which is relatively small because of the large variation of the ratio of working current to starting current.

The tetrode gun is suitable for low voltage operation and limits the dc dissipation at the high voltage end, thus reducing also the rf power variation in the band. The operating range can be determined as a function of the starting current for proper choice of the anode dynamic impedance, which is larger than in the triode

gun and allows for small control power when the tube is frequency-modulated. Finally the tetrode gun provides separate electrodes for amplitude or pulsed modulation and for manual or automatic rf power control.

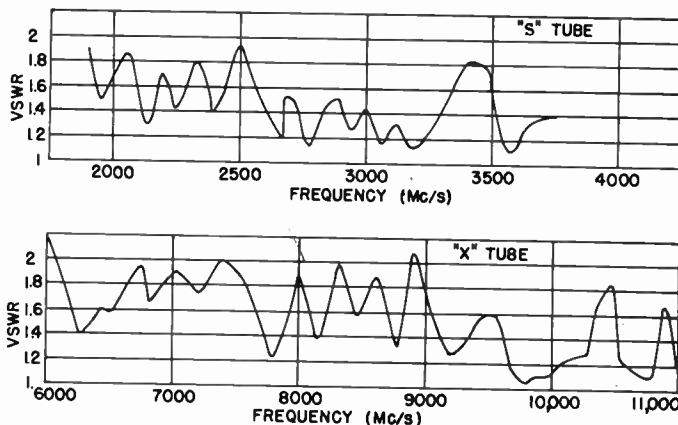

Fig. 18—Matching characteristics of S- and X-band tubes on standard 50 ohms impedance.

With cylindrical lines, ring shaped electrodes yield an annular beam traveling at a short distance from line. In most systems, flat guns are used in which beam is halved into two parallel strips flowing along both sides of line.

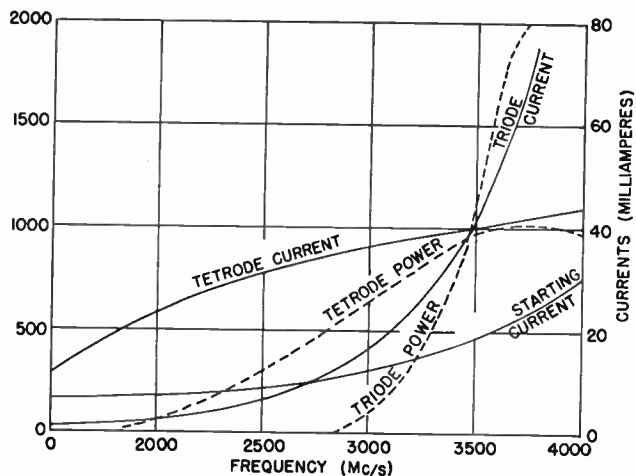

Fig. 19—Schematic characteristics of starting current, triode, and tetrode beam currents (full lines) and rf power (dotted lines).

**Focusing.** In most models permanent magnets are used for focusing the beam [32]. Owing to the short length of the lines and to the high coercive force of the magnets, relatively low weight and dimensions are ob-

TABLE IV

Type	Pitch	Dimensions of fingers (mm)	Number of fingers	Frequency range (mc)	Voltage range (volts)
CO 315	2.5 mm	32.5×2.5×1.8	48	1,000– 2,000	100–1,100
CO 119	1.17	14 ×2.1×0.7	66	2,400– 4,800	180–1,400
CO 94	0.82	8.5×1.4×0.44	94	3,600– 7,200	160–1,500
CO 43	0.58	5.4×1 ×0.26	112	6,000–11,000	250–1,400

tained for the assemblies. Some magnets consist of bars mounted on small pole pieces. For X-band tubes cylindrical magnets as shown in Fig. 20 are suitable. Usually 2 to 4 pounds of magnetic material give a sufficiently high magnetic field, of the order of 500-600 gauss.

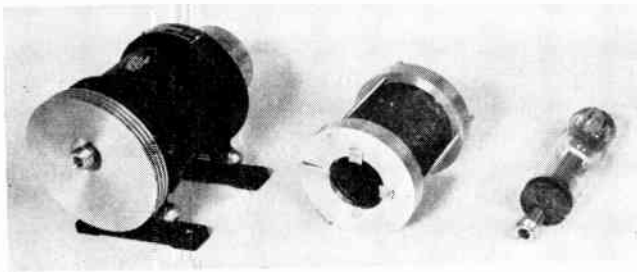

Fig. 20—Photograph of an X-band tube, cylindrical magnet and mounting.

Other tubes, employing electrostatic focusing, were also constructed. Interdigital lines (Fig. 21) have a practical interest with respect to the necessity of supplying two different voltages to alternate elements. For

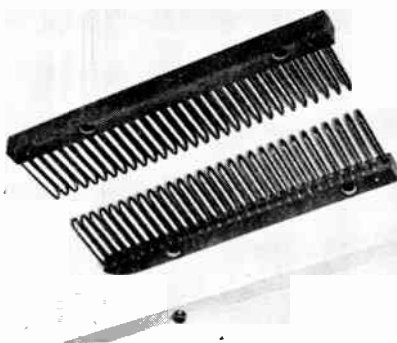
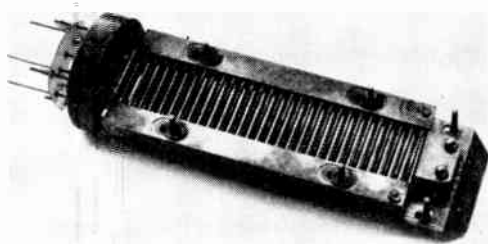

Fig. 21—Interdigital line of an electrostatically focused Carcinotron.

proper shape of fingers the low voltage elements can even be connected to the cathode. Continuous tuning bands wider than one octave were also obtained, as shown in Fig. 22 [33].

*Practical Performance Consideration.* The results reported in Section IV give a picture of the main characteristics of these tubes. Design and performances were primarily directed toward operation with wide margins of tube safety and toward general needs. In this respect tuning ranges of one octave and maximum rf power ratios of 5:1 to 10:1 are good figures. These characteristics are related to operation where only the line voltage is varied. By adjustments of the gun and focusing con-

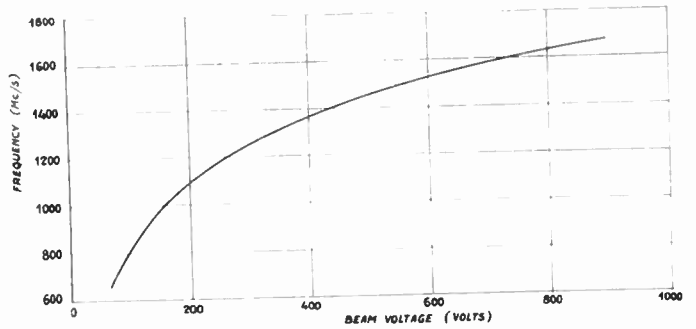

Fig. 22—Frequency voltage characteristic of an electrostatically focused Carcinotron.

ditions it would be possible to get much larger tuning bands, for instance 3,000-12,000 mc with the same X tube, but the advantage is deceiving because of difficult matching and unpractical handling of such systems.

Reliability of performance may be seen from an examination of the statistical results computed from a lot of 100 S-band tubes (Table V). Frequency and power measurements were made at the same voltages for all tubes and the error in voltage measurement is embodied in the given error figure.

TABLE V

Frequency difference	0 to 10 mc	10 to 20 mc	20 to 30 mc	>30 mc
Number of tubes at				
2,300 mc	48	28	13	11
3,000 mc	74	21	4	1
3,700 mc	66	25	6	3

RF power difference	0 to 1 db	1 to 2 db	2 to 3 db	>3 db
2,300 mc	60	24	12	4
3,000 mc	76	19	4	1
3,700 mc	79	17	3	1

The relatively large possible error in voltage measurements at low voltages and the corresponding large frequency sensitivity probably explain the spreading of frequency errors at 2,300 mc.

Finally, various characteristics are briefly reviewed. The amplitude of rf power can be controlled by two electrodes of the gun. The screen grid is appropriate for static control or automatic regulation and the negative control grid for amplitude or pulse modulation. Power equalization to 3 db over the whole band was obtained by avc system. Owing to the very short build-up time of the oscillations, of the order of  $10^{-8}$  second, very short pulses are accurately converted to the rf power as shown in Fig. 23 where input and output pulses up to 0.5 microsecond are compared.

Experiments on noise are not yet complete because of the very large frequency ranges and possibilities of working conditions. The noise output is of the same order as that of klystron local oscillators. A signal to noise ratio of 150-155 db/cycle is commonly obtained from the S-band tubes.

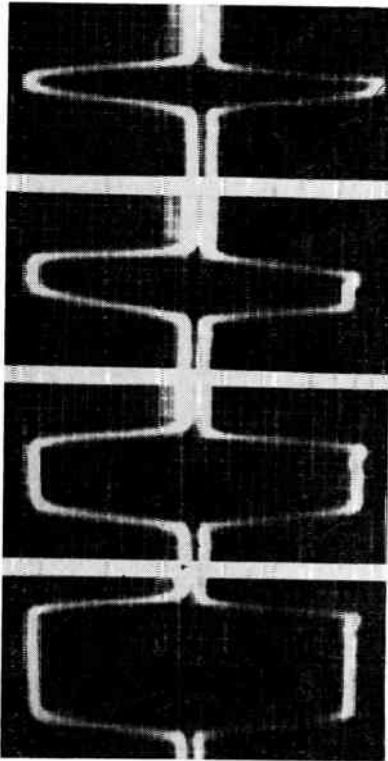

Fig. 23—Photograph of pulse-modulated signals of 3, 2, 1, 0.5 microseconds. Above: input signal. Below: output signal from the rf power.

Another type of noise can appear when the tube vibrates; it takes the form of frequency fluctuations which could be amplified at the mechanical resonance of the tube or of its mounting. Tubes such as those shown in Figs. 16 and 20 are resistant to microphonics for accelerations tested up to 4 g in the usual spectrum of mechanical vibrations.

Cooling is achieved by air blowing (Fig. 16) or natural ventilation (Fig. 20). As an example, natural cooling of X-band tubes produces at the maximum dc power rating a frequency shift of about 1/3,000 within a period of 20 minutes. Much smaller values are obtained with slight additional blowing.

Concerning life tests, only incomplete results are available at this time due to the fact the tubes under test are still running. Owing to low cathode loading, thousands of hours are expected. Special care must be taken to avoid placing the tubes in the immediate vicinity of magnetic materials and stray magnetic fields.

## VI. CONCLUSIONS

The preceding results lead to the conclusion that the basic ideas of backward-wave interaction may be correctly applied to the construction of tubes. These results are far from complete when one considers the enormous amount of work still to be done. However, the art is progressing rapidly, and there is considerable promise for greater understanding of beam-wave interaction and further development of useful devices.

One particular point is worthy of emphasis. The very principle of backward-wave operation implies a sensitivity of frequency to even small reflections and voltage fluctuations, and thus it poses the problem of frequency stability under operational conditions. For this reason, these effects were extensively discussed.

It must be pointed out that very broad-band applications do not generally call for as critical accuracy as do relatively small bandwidths. In this last case, appropriate matching of the load may, as usual, restore proper conditions in a range which is large when the delay line is short and well matched. On the other hand, regulating systems have to be used in order to prevent effects of voltage fluctuations, and a moderate regulation rate will be suitable for most broad-band applications. For accurate operation in relatively small ranges, accurate regulating systems will not be complicated owing to the corresponding small ranges of voltage and to the convenient electronic structure of the tubes.

## APPENDIX

The analysis [13] of starting conditions is similar to that used by Bernier [34] for the travelling-wave amplifier. It differs essentially by introducing a change in sign of the coupling impedance.

Terminal reflections are taken into account as follows in the calculation of the field excited in the line by the electron beam.

The waves excited at the abscissa  $z$  from a source of amplitude unity in  $x$  at left of  $z$  are:

the direct wave

$$\frac{1}{2}e^{-\Gamma_0(z-z)}$$

the wave reflected at the  $l$  or collector end

$$\frac{1}{2}r_l e^{-\Gamma_0(2l-z-z)}$$

the wave reflected at the 0 or gun end

$$\frac{1}{2}r_0 e^{-\Gamma_0(z+z)}$$

the wave successively reflected at gun and collector end

$$\frac{1}{2}r_0 r_l e^{-\Gamma_0(2l-z+z)}$$

the waves resulting from the preceding wave by a succession of an even number of reflections at 0 and  $l$ , which introduce the sum:

$$1 + \rho + \rho^2 + \dots = \frac{1}{1 - \rho}$$

where

$$\rho = r_0 r_l e^{-2\Gamma_0 l}$$

Similar results are obtained when  $x$  is at the right of  $z$ , the first and fourth terms turning respectively into  $\frac{1}{2}e^{\Gamma_0(z-z)}$  and  $\frac{1}{2}e^{\Gamma_0-(2l+z-z)}$ .

Eq. (8) of Bernier is now

$$(1 - \rho)E_z = \frac{1}{2} \int_0^z A(x) [e^{-\Gamma_0(z-x)} + \rho \cdot e^{\Gamma_0(z-x)}] dx \\ + \frac{1}{2} \int_z^l A(x) [e^{\Gamma_0(z-x)} + \rho \cdot e^{-\Gamma_0(z-x)}] dx \\ + \frac{1}{2} \int_0^l A(x) [r_0 e^{-\Gamma_0(x+z)} + r_1 \cdot e^{-2\Gamma_0 l} \cdot e^{\Gamma_0(x+z)}] dx.$$

In the continuation of the starting conditions calculations, terms in  $r_0$  and  $r_1$  are of small relative order so that only  $\rho$  survives as reflections term in the final equations (3) and (4) in Section III.

#### ACKNOWLEDGMENT

The authors are indebted to R. R. Warnecke and P. R. Guenard for their unceasing encouragement and advice throughout the research and development work. Although it is impossible to mention by name all those connected with this work, the authors would like to take this opportunity to thank the engineers and collaborators whose competent and devoted efforts made this paper possible.

#### BIBLIOGRAPHY

- [1] Warnecke, R., Guenard, P., Doehler, O., and Epsztein, B., "The M-Type Carcinotron Tube." PROCEEDINGS OF THE IRE, Vol. 43 (April, 1955), p. 413.
- [2] Tenth IRE-AIEE Electron Tubes Conference, Ottawa, Ontario, Canada, June, 1952.
- [3] Millman, S., "A Spatial Harmonic Traveling-Wave Amplifier for 6 Mm Wavelength." PROCEEDINGS OF THE IRE, Vol. 39 (September, 1951), pp. 1035-1043.
- [4] Kompfner, R., and Williams, N. T., "Backward-Wave Tube." PROCEEDINGS OF THE IRE, Vol. 41 (November, 1953), pp. 1602-1611.
- [5] Guenard, P., Doehler, O., Epsztein, B., and Warnecke, R., "Nouveaux Oscillateurs à Large Bande d'Accord Électronique pour Hyperfréquences," *Comptes Rendus d'Academie Science*, Vol. 235 (1952), p. 236.
- [6] Warnecke, R., and Guenard, P., "Some Recent Work in France on New Type of Valves for the Highest Radio Frequencies," PROCEEDINGS OF THE IRE, Part III, Vol. 100 (November, 1953), pp. 351-362.
- [7] Warnecke, R., "Sur Quelques Résultats Récentement Obtenus dans le Domaine des Tubes Électroniques pour Hyperfréquences," *Annales de Radioélectricité*, Vol. 9 (April 1954), pp. 107-136.
- [8] Guenard, P., "On Some results Obtained with O and M Carcinotrons." Paper presented at the Twelfth Conference on Electron tubes Research, University of Maine, Orono, June, 1954.
- [9] Warnecke, R., Guenard, P., and Doehler, O., "Phénomènes Fondamentaux dans les Tubes à Onde Progressive," *L'Onde Electrique*, Vol. 34 (April, 1954), pp. 323-338.
- [10] Walker, L. R., "Starting Currents in the Backward-Wave Oscillator," *Journal of Applied Physics*, Vol. 24 (July, 1953), pp. 854-859.
- [11] Pierce, J. R., "Some Recent Advances in Microwave Tubes," PROCEEDINGS OF THE IRE, Vol. 42 (December, 1954), pp. 1735-1747.
- [12] Heffner, H., "Analysis of the Backward-Wave Traveling Wave Tube," PROCEEDINGS OF THE IRE, Vol. 42 (June, 1954), pp. 930-937.
- [13] Guenard, P. and Berterottiere, C., "Courant et Fréquence d'Accrochage du T P O Oscillateur," Technical Report C.S.F. W. 7949, October 19, 1951.
- [14] Warnecke, R. and Guenard, P., "Les Tubes à Modulation de Vitesse," Gauthier Villars (Paris, 1951), Chapter XXIII, pp. 534-550.
- [15] From an unpublished work of M. Denis of C.S.F.
- [16] Mendel, J. T., Quate, C. F., and Yocom, W. H., "Electron Beam Focusing with Periodic Permanent Magnet Fields," PROCEEDINGS OF THE IRE, Vol. 42 (May, 1954), pp. 800-810.
- [17] Tien, P. K., "Focusing of a Long Cylindrical Electron Stream by Means of Periodic Electrostatic Fields," *Journal of Applied Physics*, Vol. 25 (October, 1954), pp. 1281-1288.
- [18] Chang, K. K. N., "Beam Focusing by Periodic and Complementary Fields," PROCEEDINGS OF THE IRE, Vol. 43 (January, 1955), pp. 62-71.
- [19] Tien, P. K., "Bifilar Helix for Backward-Wave Oscillators," PROCEEDINGS OF THE IRE, Vol. 42 (July, 1954), pp. 1137-1143.
- [20] Sullivan, J. W., "A Wide Band Voltage-Tunable Oscillator," PROCEEDINGS OF THE IRE, Vol. 42 (November, 1954), pp. 1658-1665.
- [21] Warnecke, R., Doehler, O., and Guenard, P., "Sur les Lignes à Retard en Forme de Peigne ou de Circuit Interdigital et sur leur Circuit Equivalent," *Comptes Rendus d'Academie Science*, Vol. 231 (1950), pp. 1220-1222.
- [22] Guenard, P., Doehler, O., and Warnecke, R., "Sur les Propriétés des Lignes à Structure Périodique," *Comptes Rendus d'Academie Science*, Vol. 235 (July, 1952), p. 32.
- [23] Warnecke, R., "L'Évolution des Principes des Tubes Électroniques Modernes pour Micro-Ondes," *Congegno di Electronica e Televisione*, Milano, April, 1954.
- [24] Leblond, A. and Mourier, G., "Étude des Lignes à Barreaux à Structure Périodique pour Tubes Électroniques, U.H.F." *Annales de Radioélectricité*, Vol. 9, pp. 311-328; April, October, 1954.
- [25] French Patents No. 1034007, 1036025, 1042930, 1045386, 1053362, 1057510, 1068673, 1068156, 1068448, 1079028, 1086890.
- [26] Denis, M. and Palluel, P., "Détermination Expérimentale des Caractéristiques de Phase des Circuits Utilisés en Ondes Centimétriques," *Annales de Radioélectricité*, Vol. 4 (October, 1949), pp. 315-330.
- [27] Epsztein, B. and Mourier, G., "Définition et Mesure des Vitesses de Phase dans les Lignes à Structure Périodique," Conférence devant la 6ème Section de la Sté des Radioélectriciens, May 6, 1953.
- [28] Epsztein, B. and Mourier, G., "Mesure de l'Impédance de Couplage des Lignes à Retard," Conférence devant la 5ème Section de la Sté des Radioélectriciens, January 15, 1954.
- [29] Leblond, A. and Mourier, G., *ibid.*
- [30] A. Karp, "Traveling Wave Tube Experiments at Millimeter Wavelengths with a New, Easily Built, Space Harmonic Circuit," PROCEEDINGS OF THE IRE, Vol. 43 (January, 1955), pp. 41-46.
- [31] Le Carcinotron O, Télonde 1955, No. 1, p. 3-20. Frequency rangés are listed as follows:
 

CO 315	1,000-2,000 mc	CO 94	3,600-7,200 mc
CO 210	1,500-3,200 mc	CO 63	4,800-9,600 mc
CO 119	2,400-4,800 mc	CO 42	7,500-15,000 mc
- [32] de Bennetot, M., "Sur le Calcul des Aimants Tubulaires," *Annales de Radioélectricité*, Vol. 9 (April, 1954), pp. 193-216.
- [33] From an unpublished work of D. Charles and R. Gentner, of C.S.F.
- [34] Bernier, J., "Essai de Théorie du Tube à Propagation d'Ondes," *Annales de Radioélectricité*, Vol. 21 (1947), pp. 87-101.



# IRE Standards on Electron Devices: Definitions of Terms Related to Microwave Tubes (Klystrons, Magnetrons, and Traveling Wave Tubes), 1956\*

## COMMITTEE PERSONNEL

### Committee on Electron Tubes, 1950-55

P. A. REDHEAD, *Chairman*, '55

W. J. DODDS, *Chairman*, '54-'55

G. D. O'NEILL, *Chairman*, '52-'54

A. L. SAMUEL, *Chairman*, '51-52

L. S. NERGAARD, *Chairman*, '50-'51

R. M. RYDER, *Vice-Chairman*, '52-'54

W. G. SHEPHERD, *Vice-Chairman*, '54-'55

A. E. Anderson

E. M. Boone

R. S. Burnap

J. W. Clark

W. J. Dodds

W. G. Dow

G. A. Espersen,

C. E. Fay

W. R. Ferris

P. A. Fleming

M. S. Glass

A. M. Glover

J. E. Gorham

J. W. Greer

L. B. Hendrick,

L. A. Hendricks

T. J. Henry

M. E. Hines

E. C. Homer

S. B. Ingram

R. B. Janes

E. O. Johnson

S. F. Kaisal

J. W. Kearney

G. R. Kilgore

W. J. Kleen

P. M. Lapostolle

C. G. Lob

S. J. Koch

H. Krauss

R. M. Matheson

B. L. McCreary

J. A. Morton

I. E. Mouromtseff

L. S. Nergaard

H. L. Owens

O. W. Pike

P. A. Redhead

H. J. Reich

A. C. Rockwood

H. Rothe

J. S. Saby

A. L. Samuel

W. G. Shepherd

R. W. Slinkman

R. G. Stoudenheimer

H. L. Thorson

M. A. Townsend

R. R. Warnecke

C. M. Wheeler

### Standards Committee 1955-56

E. WEBER, *Chairman*

M. W. BALDWIN, JR., *Vice-Chairman*

W. R. Bennett

J. G. Brainerd

P. S. Carter

P. S. Christaldi

A. G. Clavier

J. E. Eiselein

A. W. Friend

V. M. Graham

R. A. Hackbusch

H. C. Hardy

D. E. Harnett

P. J. Herbst

Hans Jaffe

Henry Jasik

A. G. Jensen

J. L. Jones

J. G. Kreer, Jr.

E. A. Laport

A. A. Macdonald

Wayne Mason

D. E. Maxwell

K. R. McConnell

R. F. SHEA, *Vice-Chairman*

L. G. CUMMING, *Vice-Chairman*

H. R. Mimno

M. G. Morgan

G. A. Morton

H. L. Owens

C. H. Page

P. A. Redhead

R. Serrell

R. M. Showers

H. R. Terhune

J. E. Ward

W. T. Wintringham

### Definitions Coordinator

M. W. BALDWIN, JR.

\* Reprints of this Standard, 56 IRE 7.S1 may be purchased while available from the Institute of Radio Engineers, 1 East 79th Street, New York, N. Y. at \$0.50 per copy. A 20 per cent discount will be allowed for 100 or more copies mailed to one address.

**Backward Wave (in a Traveling-Wave Tube)**

A wave whose group velocity is opposite to the direction of electron stream motion.

**Bunching**

The action in a velocity-modulated electron stream that produces an alternating convection-current component as a direct result of the differences of electron transit time produced by the *velocity modulation*.

**Bunching Angle (in an Electron Stream)**

In a given *drift space*, the average *transit angle* between the processes of *velocity modulation* and energy extraction at the same or different gaps.

**Bunching Parameter**

One-half the product of (a) the *bunching angle* in the absence of *velocity modulation* and (b) the depth of *velocity modulation*.

*Note:* In a reflex klystron the *effective bunching angle* must be used.

**Circuit Efficiency (of the output circuit of an Electron Tube)**

The ratio of (a) the power at the desired frequency delivered to a load at the output terminals of the output circuit of an oscillator or amplifier to (b) the power at the desired frequency delivered by the electron stream to the output circuit.

**Compression Ratio (gain or amplification)**

The ratio of (a) the magnitude of the gain (or amplification) at a reference signal level to (b) its magnitude at a higher stated signal level.

**Convection Current**

In an electron stream, the time rate at which charge is transported through a given surface.

**Convection-Current Modulation**

The time variation in the magnitude of the *convection current* passing through a surface, or the process of directly producing such a variation.

**Coupling Coefficient, Small Signal (for an Electron Stream)**

The ratio of (a) the maximum change in energy of an electron traversing the *interaction space* to (b) the product of the *peak alternating gap voltage* by the electron charge.

**Depth of Velocity Modulation, Small Signal**

The ratio of the peak amplitude of the *velocity modulation* of an electron stream, expressed in equivalent volts, to the *electron-stream potential*.

**DC Electron-Stream Resistance**

The quotient of *electron-stream potential* and the direct-current component of stream current.

**Drift Space**

In an electron tube, a region substantially free of externally applied alternating fields, in which a relative repositioning of the electrons takes place.

**Effective Bunching Angle (in a Reflex Klystron)**

In a given *drift space*, the *transit angle* that would be required in a hypothetical *drift space* in which the potentials vary linearly over the same range as in the given space and in which the bunching action is the same as in the given space.

**Electron-Gun Density Multiplication**

The ratio of the average current density at any specified aperture through which the stream passes to the average current density at the cathode surface.

**Electron-Stream Potential**

At any point in an electron-stream, the time average of the potential difference between that point and the electron-emitting surface.

**Electron-Stream Transmission Efficiency**

At an electrode through which the electron stream passes, the ratio of (a) the average stream current through the electrode to (b) the average stream current approaching the electrode.

*Note:* In connection with multitransit tubes, the term "electron stream" should be taken to include only electrons approaching the electrode for the first time.

**Electronic Efficiency**

The ratio of (a) the power at the desired frequency delivered by the electron stream to the circuit in an oscillator or amplifier to (b) the average power supplied to the stream.

**Electron Wave Tube**

An electron tube in which mutually interacting streams of electrons having different velocities cause a signal modulation to change progressively along their length.

**Forward Wave (in a Traveling-Wave Tube)**

A wave whose group velocity is in the same direction as the electron stream motion.

**Frequency Pulling**

A change of the generated frequency of an oscillator caused by a change in load impedance.

### Frequency Range (of a Device)

The range of frequencies over which the device may be considered useful with various circuit and operating conditions.

*Note:* Frequency range should be distinguished from bandwidth, which is a measure of useful range with fixed circuits and operating conditions.

### Gap Admittance, Circuit

The admittance of the circuit at a gap in the absence of an electron stream.

### Gap Admittance, Electronic

The difference between (a) the gap admittance with the electron stream traversing the gap and (b) the gap admittance with the stream absent.

### Gap Capacitance, Effective

One half the rate of change with angular frequency of the resonator susceptance, measured at the gap, for frequencies near resonance.

### Gap Loading, Multipactor

The *electronic gap admittance* resulting from a sustained secondary emission discharge existing within a gap as a result of the motion of the secondary electrons in synchronism with the electric field in the gap.

### Gap Loading, Primary Transit-Angle

The *electronic gap admittance* that results from the traversal of the gap by an initially unmodulated electron stream.

*Note:* This is exclusive of secondary emission in the gap.

### Gap Loading, Secondary Electron

The *electronic gap admittance* which results from the traversal of a gap by secondary electrons originating in the gap.

### Hysteresis (of an Oscillator)

A behavior that may appear in an oscillator wherein multiple values of the output power and/or frequency will correspond to given values of an operating parameter.

### Input Gap

An *interaction gap* used to initiate a variation in an electron stream.

### Interaction Circuit Phase Velocity (of a Traveling-Wave Tube)

The phase velocity of a wave traveling on the circuit in the absence of electron flow.

### Interaction Gap

An interaction space between electrodes.

### Interaction Impedance (of a Traveling-Wave Tube)

A measure of the radio frequency field strength at the electron stream for a given power in the interaction circuit. It may be expressed by the following equation:

$$K = \frac{E^2}{2\left(\frac{\omega}{v}\right)^2 P}$$

where  $E$  is the peak value of the electric field at the position of electron flow,  $\omega$  is the angular frequency,  $v$  is the *interaction circuit phase velocity* and  $P$  is the propagating power. If the field strength is not uniform over the beam, an effective interaction impedance may be defined.

### Interaction Space

A region of an electron tube in which electrons interact with an alternating electromagnetic field.

### Load Impedance Diagram (of an Oscillator)

A chart showing performance of the oscillator with respect to variations in the load impedance. Ordinarily, contours of constant power and of constant frequency are drawn on a chart whose coordinates are the components of either the complex load impedance or of the reflection coefficient. (See *Rieke Diagram*.)

### Mode

A state of a vibrating system to which corresponds one of the possible resonant frequencies (or propagation constants).

*Note 1:* Not all dissipative systems have modes.

*Note 2:* See **Modes, Degenerate**.

### Modes, Degenerate

A set of modes having the same resonant frequency (or propagation constant).

*Note:* The members of a set of degenerate modes are not unique.

### Mode of an Oscillator

*A) Resonator Mode:* A condition of operation corresponding to a particular field configuration for which the electron stream introduces a negative conductance into the coupled circuit.

*B) Transit-Time Mode:* A condition of operation of an oscillator corresponding to a limited range of *drift-space transit angle* for which the electron stream introduces a negative conductance into the coupled circuit.

### Mode Separation (in an Oscillator)

The frequency difference between *resonator modes* of oscillation.

### Optimum Bunching

The bunching condition that produces maximum power at the desired frequency in an *output gap*.



**Output Gap**

An *interaction gap* by means of which usable power can be abstracted from an electron stream.

**Overbunching**

The bunching condition produced by the continuation of the bunching process beyond the optimum condition.

**Peak Alternating Gap Voltage**

The negative of the line integral of the peak alternating electric field taken along a specified path across the gap.

*Note:* The path of integration must be stated.

**Performance Chart (of a Magnetron Oscillator)**

A plot on coordinates of applied anode voltage and current showing contours of constant magnetic field, power output, and overall efficiency.

**Preoscillation Current**

See **Starting Current (of an Oscillator)**.

**Pulling Figure**

The difference between the maximum and minimum frequencies reached by an oscillator when the phase angle of the reflection coefficient at the load impedance varies through  $360^\circ$  and the absolute value of this coefficient is constant and at a specified value, usually 0.20. (Voltage standing wave ratio 1.5).

**Pulling Figure (of an Oscillator)**

See **Pulling Figure**.

**Pushing Figure (of an Oscillator)**

The change of oscillator frequency with a specified change in current, excluding thermal effects. (See **Electronic Tuning Sensitivity**.)

**Reflex Bunching**

The *bunching* that occurs in an electron stream that has been made to reverse its direction in the *drift space*.

**Repeller**

An electrode whose primary function is to reverse the direction of an electron stream.

*Note:* The repeller is sometimes called the reflector.

**Resonator Mode**

See **Mode of an Oscillator**.

**Rieke Diagram (of Oscillator Performance)**

A chart showing contours of constant power output and constant frequency drawn on a polar diagram whose coordinates represent the components of the complex reflection coefficient at the oscillator load. (See **Load Impedance Diagram**.)

**Sink (of an Oscillator)**

The region of a *Rieke diagram* where the rate of change of frequency with respect to phase of the reflection coefficient is maximum. Operation in this region may lead to unsatisfactory performance by reason of cessation or instability of oscillations.

**Small-Signal Forward Transadmittance**

The value of the forward transadmittance obtained when the input voltage is small compared to the beam voltage.

**Space Charge Debunching**

Any process in which the mutual interactions between electrons in the stream disperse the electrons of a bunch.

**Starting Current (of an Oscillator)**

The value of electron-stream current through an oscillator at which self-sustaining oscillations will start under specified conditions of loading.

**Synchronous Voltage (of a Traveling-Wave Tube)**

The voltage required to accelerate electrons from rest to a velocity equal to the phase velocity of a wave in the absence of electron flow.

**Thermal Tuning Time (Heating)**

The time required to tune through a specified frequency range when the tuner power is instantaneously changed from zero to the specified maximum.

*Note:* The initial condition must be one of equilibrium.

**Thermal Tuning Time (Cooling)**

The time required to tune through a specified frequency range when the tuner power is instantaneously changed from the specified maximum to zero.

*Note:* The initial condition must be one of equilibrium.

**Transadmittance Compression Ratio**

The ratio of the magnitude of the *small-signal forward transadmittance* of the tube to the magnitude of the forward transadmittance at a given input signal level.

**Transadmittance, Forward**

The complex quotient of the fundamental components of the short-circuit current induced in the second of any two gaps and the fundamental component the voltage across the first.

**Transit Angle**

The product of angular frequency and the time taken for an electron to traverse a given path.

**Transit-Time Mode**

See **Mode of an Oscillator**.

### Transverse Beam Traveling-Wave Tube

A *traveling-wave tube* in which the direction of motion of the electron beam is transverse to the average direction in which the signal wave moves.

### Transverse Field Traveling-Wave Tube

A *traveling-wave tube* in which the traveling electric fields which interact with the electrons are essentially transverse to the average motion of the electrons.

### Traveling-Wave Magnetron Type Tube

A *traveling-wave tube* in which the electrons move in crossed static electric and magnetic fields which are substantially normal to the direction of wave propagation.

### Traveling-Wave Tube

An electron tube in which a stream of electrons interacts continuously or repeatedly with a guided electromagnetic wave moving substantially in synchronism with it, and in such a way that there is a net transfer of energy from the stream to the wave.

### Traveling-Wave Tube Interaction Circuit

An extended electrode arrangement in a *traveling-wave tube* designed to propagate an electromagnetic wave in such a manner that the traveling electromagnetic fields are retarded and extend into the space occupied by the electron stream.

*Note:* *Traveling-wave tubes* are often designated by the type of interaction circuit used, as in Helix Type Traveling-Wave Tube.

### Tuning, Electronic

The process of changing the operating frequency of a system by changing the characteristics of a coupled electron stream. Characteristics involved are, for example, velocity, density or geometry.

### Tuning Range, Electronic

The frequency range of continuous tuning between two operating points of specified minimum power output for an electronically-tuned oscillator.

*Note:* The reference points are frequently the half-power points but should always be specified.

### Tuning Rate, Thermal

The initial time rate of change in frequency which occurs when the input power to the tuner is instantaneously changed by a specified amount.

*Note:* This rate is a function of the power input to the tuner as well as the sign and magnitude of the power change.

### Tuning Sensitivity, Electronic

At a given operating point, the rate of change of oscillator frequency with the change of the controlling electron stream. For example, this change may be expressed in terms of an electrode voltage or current. (See **Pushing Figure**.)

### Tuning Sensitivity, Thermal

The rate of change of resonator equilibrium frequency with respect to applied thermal tuner power.

### Tuning, Thermal

The process of changing the operating frequency of a system by using a controlled thermal expansion to alter the geometry of the system.

### Tuning Time Constant, Thermal

The time required for the frequency to change by a fraction  $(1-1/e)$  of the change in equilibrium frequency after an incremental change of the applied thermal tuner power.

*Note 1:* If the behavior is not exponential, the initial conditions must be stated.

*Note 2:* Here  $e$  is the base of natural logarithms.

### Underbunching

A condition representing less than optimum bunching.

### Velocity Modulation

The process whereby a time variation in velocity is impressed on the electrons of a stream; also the condition existing in the stream subsequent to such a process.

### Velocity Sorting

Any process of selecting electrons according to their velocities.



# A New Pressed Dispenser Cathode\*

P. P. COPPOLA† AND R. C. HUGHES†

**Summary**—The development of a barium-activated refractory metal thermionic emitter consisting of alkaline earth aluminates dispersed in a porous matrix of tungsten-molybdenum alloy is described. The cathode is manufactured from a powdered mixture of the constituents by compressing in a die, and sintering the compact. The influences of composition of alkaline earth aluminate, composition of refractory metal, ratio of aluminate to refractory metal, and firing conditions on the properties of the cathode are considered.

The importance of chemical factors in determining optimum formulation for cathodes of this type is emphasized. In particular, the necessity for avoiding types of barium compounds capable of oxidizing the refractory metal without generating barium, and the desirability of providing a chemical system (combination of barium compound and refractory metal) capable of generating and evolving barium plus barium oxide at a rate not greatly in excess of that required for maintaining thermionic activation are demonstrated. The composition chosen for manufacture of cathodes is shown to meet the foregoing requirements, and to provide the additional favorable property of stability to air exposure of finished cathodes.

Cathodes made by the methods described here and consisting of calcium barium aluminate dispersed in a porous matrix of tungsten-molybdenum alloy have a Richardson work function of approximately 1.7 eV and an  $A$  constant of about 2. They are suitable for operation in the temperature range of 1,000–1,200°C (or higher, with shortened life). Emission density of 10 amperes/cm<sup>2</sup> with life of more than 5,000 hours is obtainable at an operating temperature of 1,130°C.

This cathode is judged to be suitable for applications requiring high continuous emission currents and long life.

## INTRODUCTION

**B**EGINNING in 1913, a large volume of work by Langmuir, Dushman, Becker and their associates, and others, led to the development and understanding of a type of thermionic emitter consisting of a metal surface activated by an adsorbed monolayer of an electropositive element. These developments are adequately reviewed by deBoer,<sup>1</sup> and Herrmann and Wagener.<sup>2</sup> The electropositive monolayer, preferably bonded through an intermediate monolayer of adsorbed oxygen, constitutes an oriented dipole giving a strong surface potential gradient which lowers the energy required for escape of an electron. The intermediate monolayer of oxygen increases the firmness of bonding of the electropositive element with consequent stronger potential gradient and lower work function, and diminished evaporation rate. The adsorption of an alkaline earth oxide on oxygen-free metal, shown by Moore and Allison<sup>3</sup> to give a surface of low work function, must

lead to the same structure formed by adsorption of the element on oxidized metal. Thoriated tungsten represents a well-known example of a cathode activated by a thin film of adsorbed electropositive elements. Other known examples have not been commercially developed until recently.

At normal cathode operating temperature the activating monolayer, even though retained by a high heat of adsorption, is subject to slow evaporation. If the cathode is to provide stable emission and have a useful life, provision must be made for replenishing the monolayer to compensate for the evaporation (and oxidation) loss. Fortuitously, in thoriated tungsten the rate of generation and diffusion of activator to the surface is approximately as needed to maintain cathode activity in good vacuum; under less favorable conditions of ion bombardment and residual oxidizing gases, a sufficiently increased rate is secured by carbonization of the cathode surface, carbon being a more active reducing agent than tungsten. Commercial development of cathodes activated by other electropositive elements (some of which produce lower work function than does thorium) has been delayed by lack of a solution to this problem of generating and dispensing the activator to the surface at a proper rate.

Recently Lemmens *et al.*<sup>4,5</sup> have succeeded in developing a barium-activated tungsten emitter suitable for use as the cathode in practical electron tubes. This  $L$  cathode consists of a molybdenum body having a cavity containing a barium compound<sup>6</sup> and closed by a porous tungsten wall. In operation, barium is generated by tungsten-reduction of the barium oxide, is dispensed via the porous wall, and activates the external surface of the porous member, which forms the thermionic emissive surface.

Though possessing desirable thermionic properties, the  $L$  cathode presents certain manufacturing and service defects. The necessity for providing a tightly closed cavity requires accurate machining of the molybdenum body and a difficult welding operation for attaching the porous tungsten. The initial use of barium-strontium carbonate as the reserve of activator creates processing and activation problems, due to the necessity of careful removal of carbon dioxide. The presence of a cavity separating the emissive surface from the heater creates problems of heat transfer and temperature uniformity. As a means of overcoming these defects, the fabrication of a barium-activated refractory metal emitter as a "solid" structure having the reserve of barium material

\* Original manuscript received by the IRE, August 17, 1955; revised manuscript received, October 3, 1955. Presented in part at The Second National Conference on Tube Techniques, Oct. 26, 1954, New York, New York, and The Electrochemical Society Meeting, May 3, 1955, Cincinnati, Ohio.

† Philips Laboratories, Irvington-on-Hudson, New York.

<sup>1</sup> J. H. deBoer, "Electron Emission and Adsorption Phenomena," Cambridge University Press, London, 1935.

<sup>2</sup> G. Herrmann and S. Wagener, "The Oxide-Coated Cathode," Chapman and Hall, Ltd., London, vol. 2, 1951.

<sup>3</sup> G. E. Moore and H. W. Allison, "Thermionic emission of thin films of alkaline earth oxide deposited by evaporation," *Phys. Rev.*, vol. 77, pp. 246–257; January, 1950.

<sup>4</sup> H. J. Lemmens, M. J. Jansen, and R. Loosjes, "Incandescible cathode," U. S. Patent No. 2,543,728; July, 1948.

<sup>5</sup> H. J. Lemmens, M. J. Jansen, and R. Loosjes, *Philips Tech. Rev.*, vol. 2, pp. 341–350; June, 1950, December, 1950.

<sup>6</sup> Normally a solid solution of barium and strontium oxides.

dispersed throughout a finely porous matrix of refractory metal is attractive. However, initial attempts in this laboratory to fabricate such cathodes from mixtures of tungsten and barium carbonate failed, with no barium evolved and no significant emission obtained. This result emphasizes the necessity, previously indicated, of providing a composition capable of generating activator at proper rate; a randomly chosen composition of barium compound and refractory metal will not, in general, constitute a good emitter.

The present investigation was initiated for the purpose of gaining an understanding of the problems of generating and regulating the supply of activator in such solid cathodes and with the object of eventual development of a practical cathode manufacturable by the simple technique of compressing and sintering a powdered mixture of refractory metal and alkaline earth compound.

#### CHEMICAL CONSIDERATIONS DETERMINING CHOICE OF SYSTEM FOR GENERATING ACTIVATOR

As previously shown, a barium compound admixed and in intimate contact with tungsten may react at relatively low temperature in a manner such as to produce no barium.<sup>7</sup> This is illustrated by the reaction of barium carbonate which proceeds quantitatively at temperatures over 600°C according to the equation:

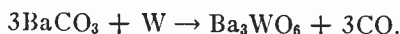

The reaction product, basic barium tungstate, does not react further with tungsten at a rate sufficient to maintain cathode activation at temperatures up to 1,300°C. Other compounds containing sufficient available oxygen will react similarly to produce no barium.

If barium oxide is brought into contact with tungsten, the reaction at cathode operating temperature is:<sup>8</sup>



The elementary barium produced, and also a portion of unreacted barium oxide, are available for thermionic activation of the tungsten. Thus, a dispersion of barium oxide in tungsten has been shown to provide very high thermionic emission density.<sup>8</sup> Though this is the type of activator source desired in a cathode, furnishing both barium and barium oxide, unmodified barium oxide is unsuitable in several respects. It is so reactive with moisture and carbon dioxide of the air that it reverts rapidly to hydroxide and carbonate. Though cathodes may be prepared from BaO by special handling or techniques, they will not be stable to air exposure. The reaction rate between BaO and W is undesirably high; excessive evaporation and short cathode life results, unless evaporation is severely restricted by mechanical means, as by the low porosity wall of the *L* cathode. The reac-

<sup>7</sup> R. C. Hughes, P. P. Coppola, and H. T. Evans, "Chemical reactions in barium oxide on tungsten emitters," *Jour. Appl. Phys.*, vol. 23, pp. 635-641; June, 1952.

<sup>8</sup> R. C. Hughes and P. P. Coppola, "Bariated tungsten emitters," *Jour. Appl. Phys.*, vol. 23, pp. 1261-1262; November, 1952.

tion rate of molybdenum with barium oxide is more appropriate, but the composition still has the defects of lack of air stability and excessive barium oxide evaporation.

Desirable characteristics for the barium compound to be employed in cathodes consisting of a barium source dispersed in a metallic matrix are:

1. Freedom from gas, in order that vacuum processing may be done rapidly.
2. Absence of available oxygen in excess of that contained as BaO.
3. Air stability, with no tendency to take up moisture or carbon dioxide.
4. Diminished reactivity and volatility as compared with BaO.

The reaction products of barium oxide with acidic oxides such as Al<sub>2</sub>O<sub>3</sub>, SiO<sub>2</sub>, and B<sub>2</sub>O<sub>3</sub> have been found to approach satisfaction of these requirements in varying degree.<sup>8</sup> A composition consisting of approximately 5 moles of barium oxide per 2 moles of Al<sub>2</sub>O<sub>3</sub> was found to provide the best combination of properties. Cathode compositions consisting of alkaline earth oxides stabilized by reaction with certain modifying oxides, in admixture with refractory metals, are described in a recently issued patent.<sup>9</sup> Application of these compositions to the preparation of cathodes by impregnation of a porous matrix from a melt of the alkaline earth compound has also been described.<sup>10</sup>

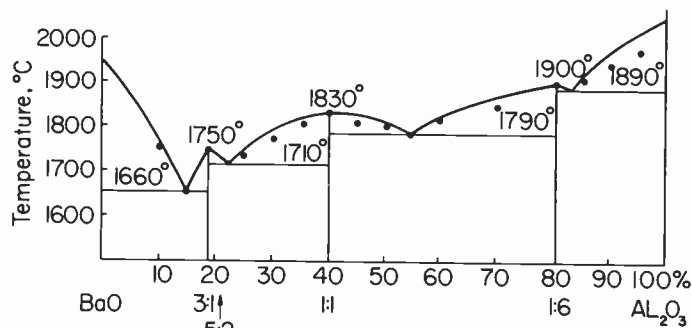

Fig. 1—Phase diagram BaO-Al<sub>2</sub>O<sub>3</sub> system.

The phase diagram for the BaO-Al<sub>2</sub>O<sub>3</sub> system<sup>11</sup> is shown in Fig. 1. The 5-2 mole ratio composition is seen to form a eutectic mixture of the compounds Ba<sub>3</sub>Al<sub>2</sub>O<sub>6</sub> and BaAl<sub>2</sub>O<sub>4</sub>.<sup>12</sup> Empirical trials of a range of compositions varying from BaAl<sub>2</sub>O<sub>4</sub> to Ba<sub>3</sub>Al<sub>2</sub>O<sub>6</sub> showed that the BaAl<sub>2</sub>O<sub>4</sub> is not reduced by tungsten at a rate sufficient

<sup>9</sup> R. C. Hughes, P. P. Coppola, and E. S. Rittner, "Incandescible cathode," U. S. Patent No. 2,700,118; November, 1951.

<sup>10</sup> R. Levi and R. C. Hughes, "Thermionic cathode and method of manufacturing same," U. S. Patent No. 2,700,000; February, 1952.

<sup>11</sup> N. A. Toropov and F. Ya. Galakov, "State diagram of the system barium oxide—Alumina," *Doklady Akad. Nauk.*, S.S.S.R., vol. 82, pp. 69-70; January, 1952.

<sup>12</sup> This composition was verified by X-ray diffraction examination of specimens prepared by fusion, rapid grinding, and sealing in fused quartz capillaries. We are indebted to the X-ray Group of this Laboratory for the X-ray examinations.

to provide a good emitter; however, its presence is beneficial in increasing air-stability and decreasing the melting point of the composition (fusion is essential for ridding the material of  $\text{CO}_2$ ). The active constituent of the mixture, tribarium aluminate, may be viewed as supplying BaO by dissociation as follows:



The free energy change for dissociation, assuming validity of Kelley's rule<sup>13</sup> (negligible entropy change) is approximated by the heat of dissociation, +10.5 kcal per mole of BaO. Dissociation of  $\text{BaAl}_2\text{O}_4$  to the oxides occurs with a heat change of +24 kcal/mole. These heats of dissociation, taken from Pepler and Newman,<sup>14</sup> permit calculation of the barium oxide and barium pressures over various systems involving these aluminates.

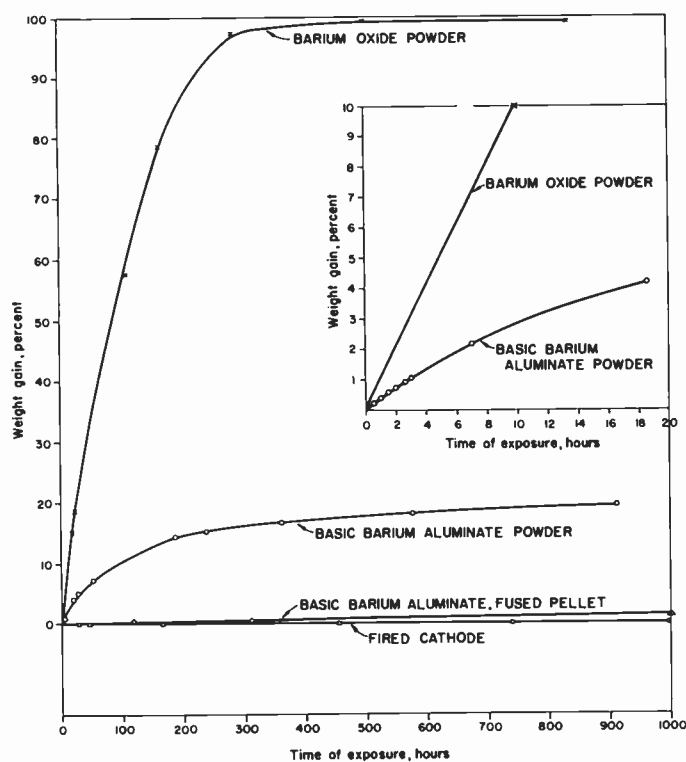

Fig. 2—Weight gain of cathode materials exposed to air (45 per cent relative humidity).

The stability to air-exposure (45 per cent relative humidity, 20°C) of the 5–2 mole ratio barium aluminate composition is indicated in Fig. 2. Data for this property were taken by continuous exposure of the samples and intermittent weighing, to nearest 0.1 mg. Weight gains are presented as percentages of the ultimate gain resulting from complete reaction with water. It will be noted that the 5–2 barium aluminate, finely powdered, though not perfectly stable, reacts slowly as

<sup>13</sup> O. Kubachewski and E. Evans, "Metallurgical Thermochemistry," Butterworth-Springer, Ltd., London; 1951.

<sup>14</sup> R. B. Pepler and E. S. Newman, "Heats of formation of some barium aluminates," *Jour. Res. Nat. Bur. Standards*, vol. 47, pp. 439–442; December, 1951.

compared to BaO. Fused pellets (ca. 2 mm diameter) are still more stable. As present in a sintered emitter wafer, the aluminate is perfectly stable, showing no detectable weight gain in 1,000 hours.

The rate of barium generation by various systems of barium compound and refractory metal is of considerable importance in determining the most suitable composition for cathodes. In the *L* cathode the rate of supply of activator is completely controllable by adjustment in porosity of the porous plug. Likewise, in the "Impregnated" cathode, the matrix may be adjusted in porosity to provide optimum performance. In contrast the cathode described here has a relatively porous matrix (ca. 40 per cent pore volume). Consequently, the rate of supply of activator to the cathode surface is not largely restricted by the matrix. In cathodes formed by pressing and sintering powdered mixtures, therefore, it is important that the chemical system be selected to generate barium at an appropriate rate determined by the minimum rate necessary to maintain cathode activation. As examples of the variations which may be encountered in rate of barium generation, a cathode consisting of 10 per cent BaO in pure tungsten reacted to exhaustion at 1,130°C in 24 hours, whereas an otherwise comparable cathode containing barium aluminate (5–2 mole ratio) and pure tungsten has a life of about 3,000 hours at the same temperature.

The rate of barium generation of various combinations of refractory metal and barium compound may be calculated by thermochemical methods.<sup>15,16</sup> The reactions responsible for the generation of barium may be represented by an equation of the type

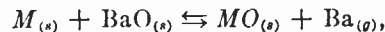

in which *M* represents a metallic reducing agent, and *MO* its oxide reaction product. The subscripts (*s*) and (*g*) designate phases present as solid (*s*) or gas (*g*). For such a reaction involving pure solid phases and a single gaseous phase, the equilibrium gas pressure is expressed by the equation

$$\Delta F_T = -RT \ln P_{\text{Ba}} = -4.575T \log P_{\text{Ba}}.$$

The free energy of reaction,  $\Delta F_T$ , may be calculated with an accuracy adequate for present purposes by simplified methods in which the heat capacities of reactants and products are neglected. The free energy of reaction is thus approximated by:<sup>13</sup>

$$\Delta F_T = \Delta H_{289} - T\Delta S_{289}.$$

Standard heat contents and entropies for this calculation are available from a recent compilation.<sup>17</sup>

<sup>15</sup> A. H. White, "Application of thermodynamics to chemical problems involving the oxide cathode," *Jour. Appl. Phys.*, vol. 20, pp. 856–850; September, 1949.

<sup>16</sup> E. S. Rittner, "A theoretical study of the chemistry of the oxide cathode," *Philips Res. Repts.*, vol. 8, pp. 184–238; June, 1953.

<sup>17</sup> F. D. Rossini, D. D. Wagman, W. H. Evans, S. Levine, and I. Jaffe, "Selected Values of Chemical Thermodynamic Properties," Nat. Bureau of Standards Circular 500; February, 1952.

TABLE I<sup>18</sup>  
CALCULATED EQUILIBRIUM PRESSURES AND EVAPORATION RATES AT 1,400°K

System	Pressure, MM Hg		Evaporation rates, micrograms/cm <sup>2</sup> /hr.		Behavior as cathode
	Ba	BaO	Ba	BaO	
W + BaO	$8 \times 10^{-5}$	$6 \times 10^{-6}$	5,200	420	Emits, short life
Mo + BaO	$1 \times 10^{-6}$	$6 \times 10^{-6}$	65	420	Emits, moderate life
W + Ba <sub>3</sub> Al <sub>2</sub> O <sub>6</sub>	$5 \times 10^{-7}$	$1.4 \times 10^{-7}$	33	10	Emits, moderate life
Mo + Ba <sub>3</sub> Al <sub>2</sub> O <sub>6</sub>	$9 \times 10^{-9}$	$1.4 \times 10^{-7}$	0.6	10	Fails to emit
W + BaAl <sub>2</sub> O <sub>6</sub>	$8 \times 10^{-10}$	$1.1 \times 10^{-9}$	0.05	.08	Fails to emit
Mo + BaAl <sub>2</sub> O <sub>6</sub>	$2 \times 10^{-11}$	$1.1 \times 10^{-9}$	0.001	.08	Fails to emit

Reaction of the barium aluminates is treated as consisting of two parts; first a dissociation:



and



followed by reduction of the barium oxide thus produced. The heats of dissociation are added to the heats of reaction of BaO with the refractory metal to obtain the total heat of reaction for the aluminate with the refractory metal. The entropy of dissociation is assumed to be negligible, in accordance with Kelley's rule.<sup>13</sup>

Barium oxide pressures over the barium aluminates may be calculated also from the heat of formation data of Pepler and Newman.<sup>14</sup>

Rates of evaporation are calculated from vapor pressures by application of the relation from kinetic theory of gases:

$$P_{\text{max}} = 17.14G \sqrt{\frac{T}{M}}$$

where  $G$  is the rate of evaporation in grams per square centimeter per second,  $T$  the absolute temperature, and  $M$  the molecular weight of evaporant. Thus, if we assume that equilibrium is reached in the reaction, and the escape of barium is unimpeded, it is possible to calculate the maximum rate at which evaporation may be expected to occur from any given cathode composition.

Calculated barium and barium oxide pressures at 1,400°K over several systems of interest are presented in Table I above. Barium pressures are calculated for the formation of normal compounds (such as BaWO<sub>4</sub>) rather than the basic compounds (as Ba<sub>3</sub>WO<sub>6</sub>) known to be formed, since thermochemical data are not available for the basic compounds. The calculated values therefore represent lower limits for barium pressure.

Barium oxide pressures of Table I, according to considerations presented by Brewer,<sup>19</sup> represent the total pressure for evaporation as the molecule and by dis-

sociation to the gaseous elements. Further, the molecule is subject to reduction by the refractory metal. As a consequence of these considerations the data presented represent upper limits to possible barium oxide pressures. However, a source of barium oxide available for activation of the cathode surface is indicated.

As noted in Table I, cathodes containing tribarium aluminate and tungsten emit well, but were found to give excessive evaporation (as compared with the  $L$  cathode) and to have only moderate life (order of 3,000 hours at 1,130°C). Since molybdenum is seen to be less reactive than tungsten, it appeared that a composition of modified reactivity might be obtained from alloys of tungsten and molybdenum. Fig. 3 shows the evapora-

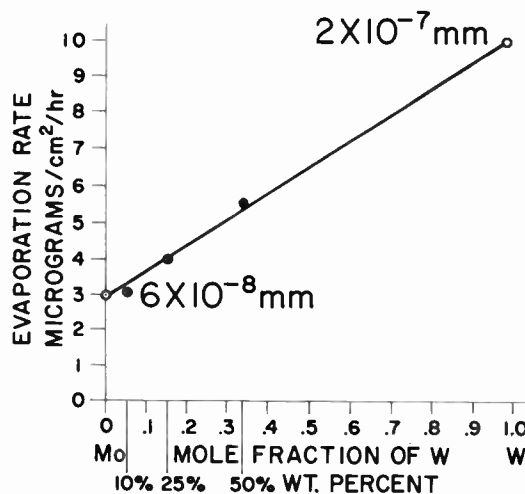

Fig. 3—Evaporation rate (Ba + BaO) at 1,400°K vs W content of alloy.

tion rate at 1,400°K (total of Ba + BaO)<sup>20</sup> obtained from compositions of barium aluminate plus W-Mo alloys as a function of alloy composition. The vapor pressure (as Ba) corresponding to the maximum and minimum evaporation rates are also indicated in Fig. 3. It will be seen that the increase in evaporation over that occurring with pure Mo is directly proportional to the molal concentration of tungsten in the alloy. The evaporation occurring with molybdenum is assumed to be almost entirely BaO, while the increase due to tungsten must represent Ba generated by tungsten reaction. Assuming that evaporation from the cathode is somewhat impeded

<sup>20</sup> Average over 1,000 hours life, determined by acidimetric titration.

<sup>18</sup> BaO pressure over systems containing a solid BaO phase is taken from the literature as the experimentally determined BaO vapor pressure. A. Classen and C. F. Veenemans, "Vapor-pressure measurements of BaO, SrO, CaO, and their mixtures," *Z. Phys.*, vol. 80, pp. 342-357; January, 1933.

<sup>19</sup> L. Brewer, "The thermodynamic properties of the oxides and their vaporization processes," *Chem. Rev.*, vol. 52, pp. 1-75; February, 1953.

by the porous matrix, these experimentally determined evaporation rates are in satisfactory agreement with the calculated rates of Table I.

The effect on equilibrium barium pressure of alloying an active reducing agent with an inert metal may be easily derived. For reaction of the type illustrated by the equation

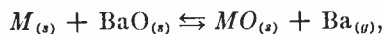

the equilibrium constant is expressed by<sup>21</sup>

$$K_p = \frac{A_{\text{MO}} \cdot A_{\text{Ba}}}{A_M \cdot A_{\text{BaO}}},$$

where  $A_{\text{MO}}$ , etc., represent the activities of products and reactants. The activity of a pure solid phase is unity,<sup>22</sup> while the activity of a gaseous phase is equal to its pressure. If the reducing metal is present as a pure solid phase, the equilibrium barium pressure is equal to the equilibrium constant:

$$K_p = A_{\text{Ba}} = P_{\text{Ba}}.$$

If, however, the reducing agent is present not as a pure phase, but is in solid solution in an alloy, its activity, no longer unity, appears in the expression relating barium pressure to the equilibrium constant

$$K_p = \frac{A_{\text{Ba}}^1}{A_M^1},$$

where  $A_{\text{Ba}}^1$  and  $A_M^1$  are activities of barium and of reducing agent pertinent to the solid solution.

$$P_{\text{Ba}}^1 = K_p A_M^1.$$

If the alloy behaves as an "ideal" solution, the activity of the reducing agent is equal to its concentration in the alloy, expressed as mole fraction.<sup>13</sup> Therefore,

$$P_{\text{Ba}}^1 = P_{\text{Ba}} \cdot C_M$$

where  $P_{\text{Ba}}^1$  is the equilibrium pressure over the alloy,  $C_M$  is the mole fraction of reducing agent,  $M$ , in the alloy, and  $P_{\text{Ba}}$  is the equilibrium pressure of barium over a pure phase of the reducing agent. This calculation thus confirms the evidence of Fig. 3 that barium evolution (proportional to equilibrium pressure) is directly proportional to the tungsten content of the alloy.

During early stages of this investigation, the evolution from barium aluminate-tungsten compositions of significant proportions of BaO and its accumulation on the anodes of experimental diodes was noted. This observation is consistent with the calculated BaO pressure of Table I. In view of the known effectiveness of BaO in activating refractory metal surfaces,<sup>3</sup> and the known beneficial effect of an oxygen monolayer for bonding the adsorbed barium activator, an important role in cathode

activation must be ascribed to this barium oxide. The *reaction* of barium oxide with the metals of concern here occurs with an increase in free energy; hence the reaction does not proceed spontaneously. In contrast, the *adsorption* of barium oxide by a clean tungsten surface occurs with a large decrease in free energy (all adsorption processes occur with decrease in free energy), and hence proceeds spontaneously until the adsorptive surface is saturated. In accordance with the principle that any chemical system tends to assume the condition of minimum free energy, the first process which can occur when barium oxide is heated in contact with tungsten (or molybdenum) is the energetic adsorption of barium oxide. This adsorbed barium oxide is mobile at temperatures below that at which it is appreciably volatile, and hence can diffuse to the cathode emitting surface. By this process, the emitter surface is activated in part by barium oxide and depletion of the oxygen monolayer desired for bonding barium at the emitter surface is thus avoided. At the same time a proportion of barium in the activator supply, in addition to BaO, is essential to prevent an excessive surface oxidation from developing.

On the basis of the foregoing information, a cathode composition consisting of 10 per cent by weight of barium aluminate ( $5\text{BaO}:2\text{Al}_2\text{O}_3$ ) and 90 per cent of Mo-W alloy (25 per cent weight W) was chosen as providing an excellent combination of air stability, freedom from gas, rapid activation, high emission density, long emission life, and diminished Ba and BaO evaporation rates. A further improvement in this composition, obtained by the addition of small proportions of CaO to the aluminate, has recently been effected. This improvement was first demonstrated by R. Levi of this Laboratory, in the "impregnated" cathode.<sup>23</sup> The mechanism by which CaO produces improved emission is not yet clear. Detailed information on the manufacture of cathodes from this composition will be presented in following sections.

#### THE PREPARATION OF CATHODES

Cathodes are formed by compressing the powdered mixture of barium compound and refractory metal and firing the compact under suitable conditions to cause sintering and produce a coherent, strong mass. Having available a composition of suitable chemical and physical properties, one may produce a variety of sizes and shapes of cathode by this method. The cathode may be formed as an integral part of a molybdenum support and heater cavity, or may be produced as an emitter shape which can be subsequently welded to the necessary support member. As an illustration of the method, the fabrication of 3-mm diameter planar cathodes forming one end of a molybdenum cylinder will be described. The cylinder serves as a means of mounting the cathode, and as a heater cavity. A finished cathode of this type, mounted for use in a cathode ray tube, is in Fig. 4.

<sup>21</sup> H. S. Taylor and S. Glasstone, "A Treatise on Physical Chemistry," D. Van Nostrand Co., New York, N. Y., Vol. 1; 1942.

<sup>22</sup> S. Glasstone, "Textbook of Physical Chemistry," 2nd ed., D. Van Nostrand Co., New York; 1946.

<sup>23</sup> R. Levi, "Improved 'Impregnated Cathode,'" *Jour. Appl. Phys.*, vol. 26, p. 639; May, 1955.

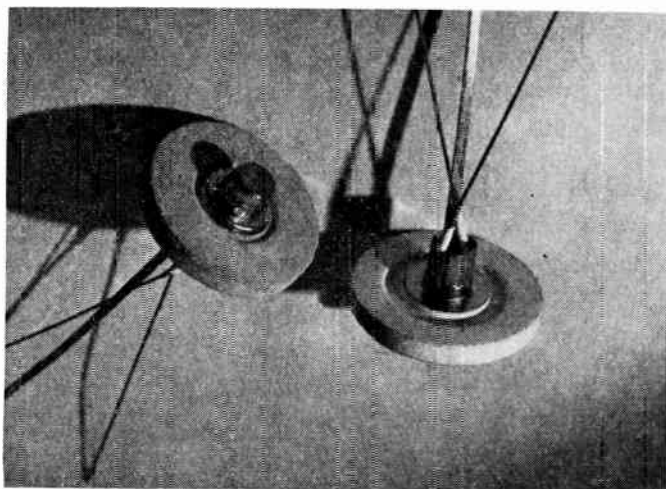

Fig. 4—Pressed cathode mounted for use in a cathode-ray tube.

#### Preparation of Emitter Mixture

Constituents for forming the desired barium aluminate composition (either with or without CaO) are weighed out and mixed in the following proportions:

BaCO <sub>3</sub>	5 moles
Al <sub>2</sub> O <sub>3</sub>	2 moles

or

CaCO <sub>3</sub>	0.3 mole
BaCO <sub>3</sub>	5 moles
Al <sub>2</sub> O <sub>3</sub>	2 moles.

The mixture is fired in air at a temperature sufficient to react and fuse the resulting aluminate compounds. The cooled product is finely ground, passed through a 325 mesh U.S. sieve, and stored with protection from air.

Tungsten-molybdenum alloy (25 weight per cent W) is obtained as a powder of desired particle size range. Sintering and shrinkage characteristics of the emitter mixture are controlled by selection of alloy of proper particle size.

The barium aluminate (10 per cent by weight) and alloy powder (90 per cent) are mixed together thoroughly and stored for subsequent use with protection from air.

#### Pressing Cathodes

The powdered emitter mixture is introduced (measured volume) into a molybdenum cylinder positioned in a die. Suitable plungers are placed in the die, and pressure (70 tons/inch<sup>2</sup>) applied by a hydraulic press. The compact is ejected from the die and sintered in vacuum or (preferably) hydrogen at a temperature of 1,750°C (uncorrected brightness temperature measured on molybdenum by optical pyrometer). Proper firing is an important feature of the cathode preparation. The high temperature employed causes sintering of the metal powder to form a hard, strong matrix,<sup>24</sup> and ensures a

<sup>24</sup> Small sintered emitter wafers have a strength in compression of approximately 50 tons per square inch.

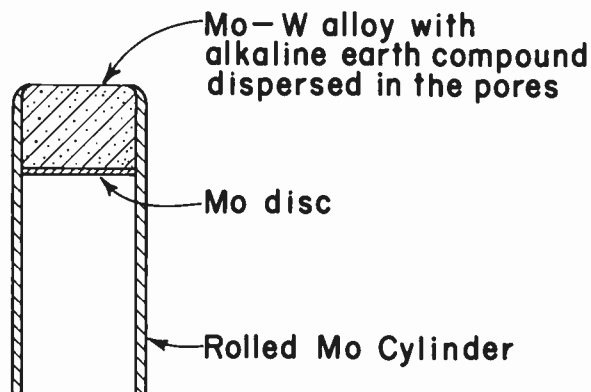

Fig. 5—Sectional view of pressed emitter in a molybdenum cylinder.

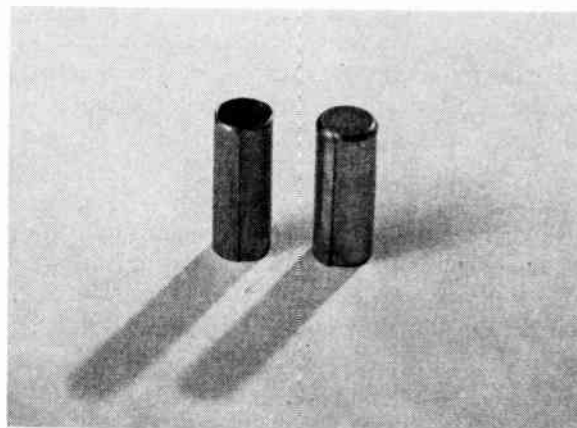

Fig. 6—Molybdenum cylinder and a formed cathode.

good bond to the molybdenum cylinder. Fusion of the aluminate during the firing operation aids in removing residual gases and causes its homogeneous dispersion throughout the porous matrix.

Fig. 5 shows a sectional view of the pressed emitter formed in a molybdenum cylinder. Fig. 6 shows the molybdenum cylinder employed; and a formed cathode. The molybdenum cylinder has been made by rolling sheet molybdenum to form a lapped, unwelded seam. Such cylinders are manufactured inexpensively as compared to the present cost of seamless tubing or machined cylinders. The die employed for forming cathodes in these sleeves has a plunger shaped so as to produce radial compression at the top edge of the cylinder. This ensures good bonding between the emitter and sleeve during the firing operation.

Fired cathodes have been examined optically<sup>25</sup> for surface flatness. Over a diameter of 3 mm, the surfaces have been found to deviate no more than 3 microns from a flat.

#### Evaluation of Cathodes

For studies of emission characteristics of the cathodes, they are mounted as a planar diode structure in a small bulb with stem leads and pumping tubulation. The tube

<sup>25</sup> By R. Bronnes, of this Laboratory.



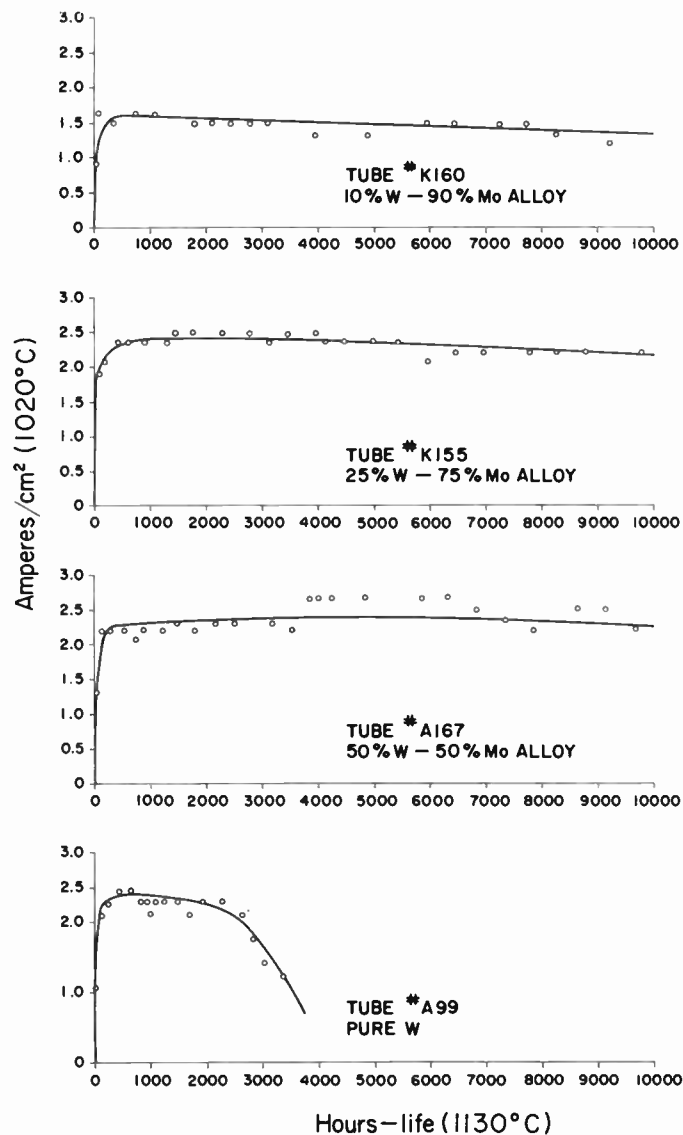

Fig. 7—Emission density and life of barium aluminate cathode as a function of tungsten content of alloy.

is sealed on a processing system consisting of a 3-stage oil diffusion pump capable of providing residual pressure of less than  $10^{-6}$  mm Hg, and a temperature-controlled "bake-out" oven. Following establishment of good vacuum, the experimental tube is heated for 1 hour at  $450^{\circ}\text{C}$  to remove surface gas. To activate the cathode, heater voltage is applied and the temperature of the cathode brought up to  $1,200^{\circ}\text{C}$  in about 5 minutes. The anode is degassed by rf heating. A positive potential of 300 volts is applied to the anode; emission current rises and stabilizes within about 1 minute. A barium-type "getter" included in the envelope is degassed, barium is evaporated onto the envelope, and the tube is sealed off from the vacuum system. At this stage of processing, the emission density obtainable from the cathode is about  $\frac{1}{2}$  of the stable value attained after brief aging.

Emission densities obtainable from the cathodes are measured principally by a pulse technique (1,000 volts on anode, 100 microsecond pulse length, repetition rate

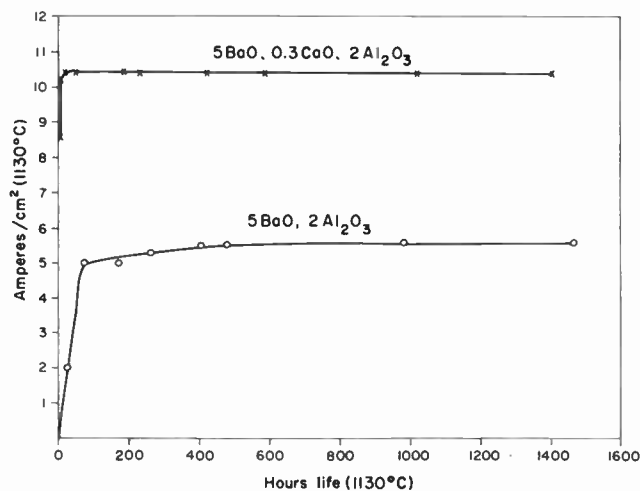

Fig. 8—Improved emission resulting from addition of CaO to barium aluminate.

20 pulses per second). In the diode structure employed, an anode potential of 1,000 volts assures temperature-limited (saturated) emission. A pulse technique is desirable for avoiding the severe anode heating which would occur in drawing continuous emission at the high power dissipation encountered in these measurements.

Emission life is tested by aging the cathodes continuously at a temperature of  $1,130^{\circ}\text{C}$ , either with or without anode current being drawn. Emission density is measured periodically, usually at a temporarily lowered cathode temperature of  $1,020^{\circ}\text{C}$ . Outgassing of anodes is minimized by use of the lowered temperature for the emission measurement. Under present conditions of manufacture and processing, this effect is no longer important.

Fig. 7. presents information on emission current density (at  $1,020^{\circ}\text{C}$ ) and life (at  $1,130^{\circ}\text{C}$ ) for several compositions based on barium aluminate (no CaO) and varying matrix metals. The substantial increase in life produced by the molybdenum alloy is evident. Emission density is unaffected by addition of molybdenum up to 75 per cent by weight. At 90 per cent molybdenum, a significant reduction in emission is noted, while a further increase in molybdenum decreases the emission to zero at 100 per cent molybdenum (not shown in Fig. 7). The increase in life of the emitters made from the alloys is consistent with the diminished evaporation rates presented in Fig. 3.

The improved emission at  $1,130^{\circ}\text{C}$  resulting from the addition of a small proportion of CaO to the barium aluminate is shown in Fig. 8. An increased emission by a factor of approximately 2 is obtained at this temperature. A further beneficial effect is obtained in a shortened time for complete activation of the cathode (a small part of the observed improvement must be attributed to the slightly higher activation temperature of  $1,190^{\circ}\text{C}$  employed for the CaO-containing cathode as compared to an activation temperature of  $1,130^{\circ}\text{C}$  employed for the cathode without CaO).

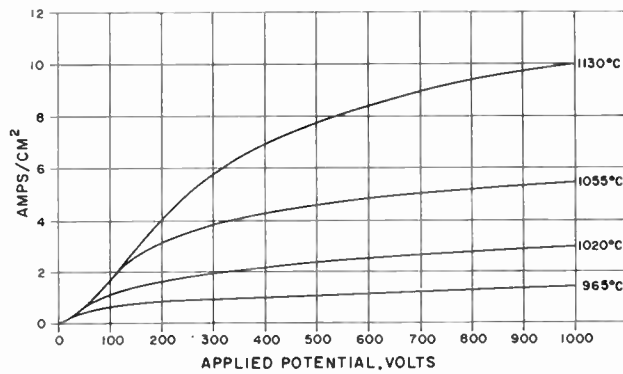

Fig. 9—Current voltage characteristics of the pressed cathode (contains CaO).

Fig. 9 shows the current versus anode voltage ( $I$ - $V$ ) characteristics of the pressed cathode for four cathode temperatures. The diode used for the measurements was a planar type with anode-cathode spacing (hot) of about 0.4 mm. Measurements were made on apparatus of the type described by Loosjes and Vink.<sup>26</sup> An RC network is periodically discharged across the diode. A signal proportional to the current is fed into the y amplifier of an oscilloscope while a signal proportional to the potential drop across the diode is fed into the x amplifier. At a pulse repetition rate of 60/second, a continuous display of the cathode  $I$ - $V$  characteristic is obtained on the oscilloscope. The oscilloscope trace is photographed to provide a record of the measurement.

Fig. 10 shows  $I$ - $V$  characteristics taken by the pulse method described above, as compared with results obtained with continuous positive anode voltage. Very close correspondence between the pulsed and continuous emission is seen at the lower cathode temperatures. A slight deficiency in continuous emission at 1,130°C is due, presumably, to the release of gas from the anode.<sup>27</sup> Thus the severe emission decay effects and resulting large deficiency in continuous emission as compared with the pulsed emission at low duty, cycle found to occur with oxide-coated cathodes, are not observed in this cathode. As a consequence, the pressed cathode is better adapted than the oxide cathode to operating conditions requiring continuous emission density exceeding 1 ampere per square centimeter.

Data for Schottky and Richardson plots were obtained for cathodes containing barium aluminate, and for cathodes containing calcium barium aluminate. The Richardson plots, shown in Fig. 11, indicate that the work functions are the same, 1.7 ev at 0°K for both modifications of the cathode. The  $A$  constant is 1.8 amps/cm<sup>2</sup>/degree<sup>2</sup> for the former and is 2.4 amps/cm<sup>2</sup>/degree<sup>2</sup> for the latter.

<sup>26</sup> R. Loosjes and H. J. Vink, "The  $i$ ,  $V$  characteristic of the coating of oxide cathodes during short-time thermionic emission," *Philips Res. Repts.*, vol. 2, pp. 190-204; June, 1947.

<sup>27</sup> Prior to these measurements, the anode has been degassed by setting the cathode temperature at the highest level at which measurements are to be made, and drawing plate current until the emission is stable. If this precaution has not been observed, a more pronounced slump in emission current will be observed.

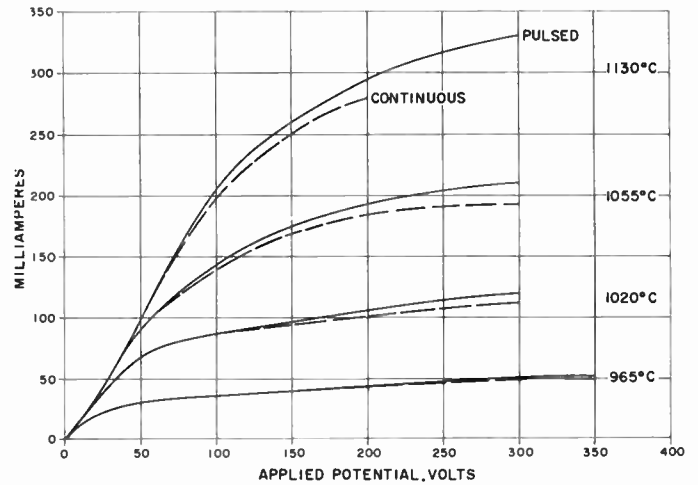

Fig. 10—Pulsed and continuous emission characteristics of pressed cathodes. Solid line indicates pulsed characteristic, broken line continuous emission.

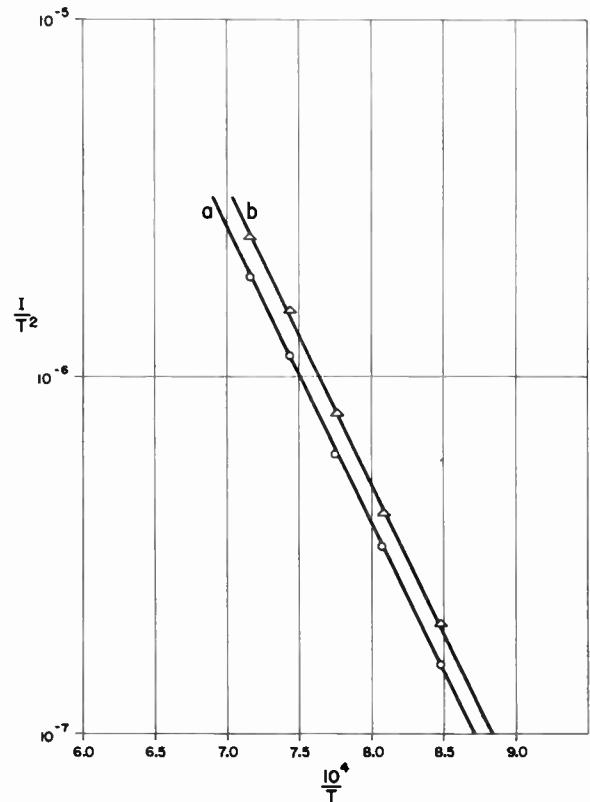

Fig. 11—Richardson plots; (a) without CaO, (b) with CaO.

The activation of the cathode surface at low activating temperature (900°C) and eventual distribution of emission over the cathode surface has been examined by mounting the cathode in a small cathode-ray tube and observing the enlarged electron image formed on the screen.<sup>28</sup> Typical electron images obtained during this study are presented in Fig. 12. These illustrations indicate that emission begins at small isolated areas of the cathode. In time these active areas increase in number and intensity and spread until the entire cathode emits rather uniformly.

<sup>28</sup> We are indebted to W. Atkinson of this Laboratory for these measurements.

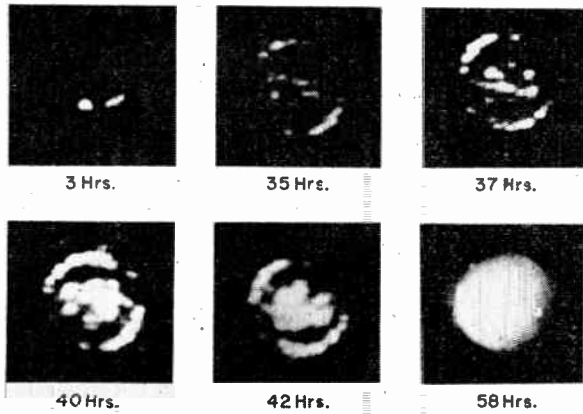

Fig. 12—Micrographs representing development of cathode emission during activation at 900°C.

#### Effects of Poor Vacuum on Cathode Activation

Vacuum conditions described up to this point for processing cathodes were designed to ensure that no faulty functioning could be due to inadequate vacuum. Though these conditions are in accordance with ordinary laboratory procedures, they are unnecessarily stringent for factory operation, where cathodes may be processed on mechanical pumps and a getter employed for establishing final vacuum in the sealed-off tube. Accordingly, the processing of "pressed" cathodes under mechanical pump vacuum in the range of  $10^{-2}$  to  $10^{-3}$  mm Hg was investigated. In "gettered" tubes, following tip-off, no significant differences in activation time and emission density result from processing at  $10^{-3}$  mm, as shown in Fig. 13. At  $10^{-2}$  mm, and while on the pump, severe ion bombardment caused a decrease in attainable emission; however, after tip-off, the cathode exhibited normal behavior. The conclusion appears to be justified, therefore, that mechanical pumps maintaining pressure in the vicinity of  $10^{-3}$  mm will be adequate for processing tubes containing these cathodes.

#### Effects of Repeated Air Exposure

Convenient commercial use of cathodes requires (or at least makes highly desirable) that the cathodes be stable in storage prior to use. It is also desirable that a cathode be stable to air exposure after activation. This permits the reuse of cathodes in rejected devices which may be reworked. It also permits the manufacture of demountable tubes, either for experimental purposes, or for limited commercial application. The oxide-coated cathode fails entirely to meet these requirements, having very poor storage properties and being completely ruined by exposure to air after activation. The behavior of the pressed cathode under conditions of repeated air-exposure followed by reprocessing and reactivation is illustrated by Fig. 14. No effect on activation time or emission density results from the first 5 exposures. The 6th and 7th exposure result in a slight decrease in emission. Cathode is therefore sufficiently stable to permit reuse in reject tubes which must be opened and reworked; it has a limited applicability in demountable tubes.

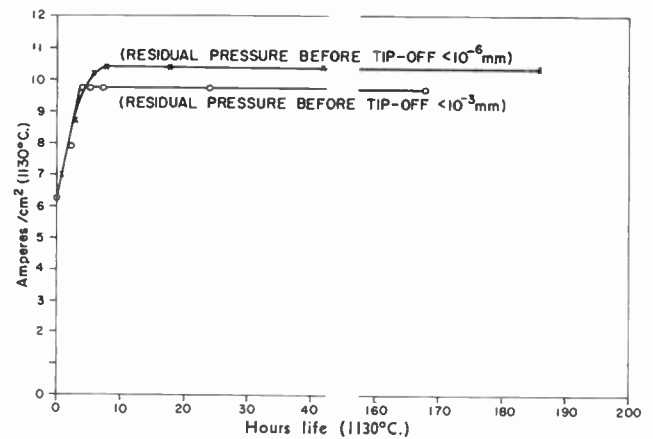

Fig. 13—Comparative emission density for cathodes processed under different vacuum conditions.

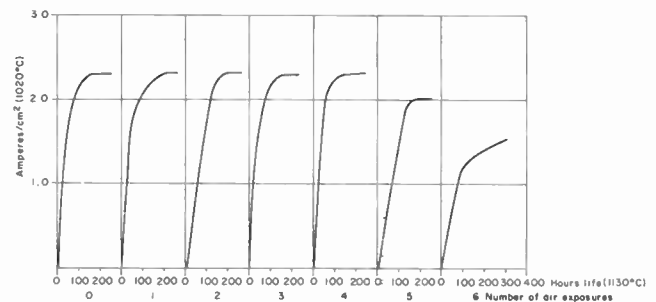

Fig. 14—Behavior of a pressed cathode containing barium aluminate under conditions of repeated air exposure.

#### SUMMARY AND CONCLUSIONS

The cathode described here is well adapted to mass production, possibly by automatic machinery, at a moderate cost. Its stability in storage and to air exposure after initial activation offer promise of convenient routine use in manufacture. The metallic nature of the finished emitter provides a rugged cathode not subject to mechanical damage in handling and assembly. The refractory nature of all its constituents permits operation at elevated temperature and high emission densities without damage. A specially chosen composition of refractory metal alloy and barium source ensures a low rate of barium generation which results in a low barium and barium oxide evolution and consequent long life. The most promising field of application of this cathode is in applications requiring high continuous emission density with long life. A conservative rating in this respect is 10 amps/cm<sup>2</sup> for 5,000 hours.

#### ACKNOWLEDGMENT

The authors appreciate the continued interest and encouragement of O. S. Duffendack, President and Director of Research of Phillips Laboratories, without which this work could not have been successfully concluded. It is a pleasure also to acknowledge the skilled technical assistance of J. Marchewka in the fabrication and testing of cathodes, of G. Low in the construction of glass apparatus, of R. Norgren for a number of *I-V* measurements and of A. DePaul for assistance in preparing the molybdenum alloys.

# Junction Transistors with Alpha Greater than Unity\*

H. SCHENKEL† AND H. STATZ‡

**Summary**—This paper describes briefly charge-carrier multiplication, avalanche breakdown, and the effect of  $\alpha$  greater than unity in junction transistors. The electrical characteristics in the  $\alpha > 1$  region and for the transition from  $\alpha < 1$  to  $\alpha > 1$  are discussed. One example of the useful applications is included in order to discuss some of the effects of the transistor parameters on circuit performance and to show the order of magnitude of the operating parameters. If the variation of  $\alpha$  with emitter current is considered, it is found that even without base connection ( $I_B = 0$ ) the transistor can have a region of negative differential resistance. Such a two-terminal device with nonthermal negative resistance is useful in various circuits.

## INTRODUCTION

IN MOST applications of junction transistors, the operating voltage of the collector junction has been limited to values far below the junction breakdown voltage. There are several reasons for this. First, the useful operation at low supply voltages was in many cases an advantage in circuit design. The extensive application in small signal amplifiers was made preferably at battery voltages below 6 volts. Yet the junction breakdown voltage was normally higher than 60 volts, because the resistivity of the base material was chosen relatively high in order to obtain good current amplification. Another reason for the use of low collector voltages was the surface leakage current across the collector junction. High leakage, as found in early transistors at high voltages, not only increases current and power-dissipation levels, but also decreases reliability and life expectancy of the transistor. Still another reason was the extensive use of the common emitter connection, which in most circuits, especially with stabilized base current, results in a collector-to-emitter breakdown voltage appreciably lower than the collector junction breakdown voltage.<sup>1</sup>

In the past two years, a general expansion of applications and operating ranges for junction transistors has taken place. This includes new circuits specifically designed for transistors, as well as the development of high-frequency and power transistors, and of types capable of operating under extreme bias conditions. Extensive research and production improvements have greatly reduced the leakage currents and improved stability, which allowed the use of higher collector voltages and made possible quantitative studies of the junction breakdown mechanism. It was found that in the pre-breakdown region a charge-carrier multiplication oc-

curs.<sup>1-4</sup> The breakdown is an avalanche-like increase of this multiplication with a feedback mechanism, since electrons and holes ionize at approximately the same rate.

The fact that the junction reverse voltage is limited by the avalanche breakdown and not by the Zener effect<sup>5</sup> is important to device and circuit engineers. The Zener mechanism does not cause any current multiplication and the breakdown essentially occurs when the maximum electric field strength within the junction exceeds a critical value; whereas, the avalanche breakdown is preceded, at voltages in the prebreakdown region, by current multiplication within the junction. This multiplication leads to values of the emitter current amplification greater than unity. Thus, in junction transistors, the current amplification  $\alpha$  is less than, equal to, or greater than unity depending on the collector voltage. Therefore, many new applications of junction transistors are possible. Junction transistors can replace point-contact transistors, since in the  $\alpha$ -greater-than-unity region, their electrical characteristics are basically similar.

In addition, junction transistors can handle much higher current pulses and dissipation energies, and they are generally more reliable. Furthermore, the use of complementary types ( $p-n-p$  and  $n-p-n$ ), the possibility of switching  $\alpha$  from greater than to less than unity, and the symmetry of the device (emitter and collector junctions are physically alike) which allows operation in either direction are features available only in junction transistors.

A special type of junction transistor, the  $p-n-p-n$  (or  $n-p-n-p$ ) structure, also has  $\alpha$  values greater than unity, but this device will not be discussed here. The discussions in this paper are given for  $p-n-p$  structures, but with the appropriate changes they also apply to  $n-p-n$ .

## CHARGE-CARRIER MULTIPLICATION AND CURRENT AMPLIFICATION $\alpha$

The current in ideal  $p-n$  junctions increases rapidly when the junction voltage reaches a certain value. This phenomenon has been explained by McKay and McAfee.<sup>3,4</sup> In germanium and silicon junctions, whose space-charge regions are not extremely narrow, a charge-

\* Original manuscript received by the IRE, September 6, 1955; revised manuscript received, October 13, 1955. This paper has been presented at the IRE-AIEE Semiconductor Device Research Conference, University of Pennsylvania, Philadelphia, June 1955.

† Raytheon Manufacturing Company, Waltham, Mass.

‡ H. Schenkel and H. Statz, "Voltage punch-through and avalanche breakdown and their effect on the maximum operating voltages for junction transistors," *Proc. Nat. Elect. Conf.*, vol. 10, pp. 614-625; 1954.

<sup>1</sup> S. L. Miller, papers given at IRE-AIEE Semiconductor Device Research Conferences; June 1954 (University of Minnesota); and June 1955 (University of Pennsylvania).

<sup>2</sup> K. G. McKay and K. B. McAfee, "Electron multiplication in silicon and germanium," *Phys. Rev.*, vol. 91, pp. 1079-1084; September, 1953.

<sup>3</sup> K. G. McKay, "Avalanche breakdown in silicon," *Phys. Rev.*, vol. 94, pp. 877-884; May, 1954.

<sup>4</sup> C. Zener, "A theory of the electrical breakdown of solid dielectrics," *Proc. Roy. Soc. (London)*, vol. 145, pp. 523-529; July, 1934.

carrier multiplication occurs. Electrons and holes may reach high enough energies in the region of high field to excite an electron from the valence band to the conduction band and thus produce electron-hole pairs. The effect is similar to the ionization in gas discharge tubes. The excitation rate increases with the electric field strength in the junction and, therefore, with the junction voltage. A multiplication factor  $m$  is defined as the ratio of the actual junction current to the current that would flow if there were no excitation effect.  $m$  as a function of the junction voltage  $V$  is shown by the solid line in Fig. 1.<sup>3</sup> The voltage scale on the abscissa is normalized to the avalanche breakdown voltage  $V_A$ . For low voltages,  $m$  is close to unity; *i.e.*, no appreciable multiplication effect is present. With increasing voltage, the multiplication factor increases until at  $V = V_A$  a true breakdown, called avalanche breakdown, occurs.

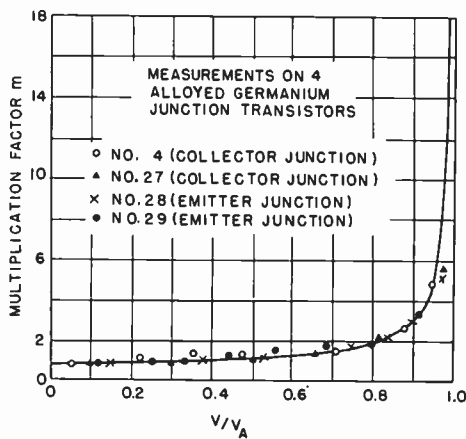

Fig. 1—Multiplication factor  $m$  vs the junction voltage for germanium transistors.

the junction is large enough so that electrons can “tunnel” from the valence to the conduction band.

Recent experiments with Raytheon alloyed transistors having base resistivities as low as 0.02 ohm cm show that the mechanism of increasing reverse current is charge-carrier multiplication and avalanche breakdown. Reverse current characteristics on several alloyed junctions have been measured with the junctions first illuminated and then in darkness. Illumination was used in order that the junction currents be so large that any possible leakage across the junction could be neglected. In all such cases,  $m$  closely followed the curve in Fig. 1.

Current multiplication occurs for minority carriers that were injected by the emitter and have diffused through the base to the collector junction. Thus, the emitter-to-collector current amplification  $\alpha$  is

$$\alpha \equiv \left. \frac{dI_c}{dI_B} \right|_{V_c} = \gamma\beta\alpha^*m. \tag{2}$$

Here,  $\gamma$  is the emitter efficiency and  $\beta$  the transport factor.  $\alpha^*$  represents the effect of increased minority carrier current from collector to base due to an electric field in the collector resulting from the majority carrier current.<sup>8</sup>  $\alpha^*$  is usually unity or only slightly larger. In this paper,  $\alpha^*$  will be called the “collector efficiency,” and as defined above,  $m$  is the collector current multiplication factor.

At collector voltages lower than 25 per cent of the avalanche breakdown voltage,  $m$  is practically equal to one and the low voltage  $\alpha$  called  $\alpha_0 (= \gamma\beta\alpha^*)$  is less than one.  $m$  increases with collector voltage and at a certain  $V_c$ , defined as  $V_\alpha$ ,  $\alpha = 1$ ; for  $V_c > V_\alpha$ ,  $\alpha > 1$ . The base current amplification

$$\alpha_{cB} \equiv \left. \frac{dI_c}{dI_B} \right|_{V_c} = \frac{\alpha}{1 - \alpha} \tag{3}$$

is positive for  $\alpha < 1$ , infinite at  $\alpha = 1$ , and negative for  $\alpha > 1$ . The variation of  $\alpha$  and  $\alpha_{cB}$  with  $V_c$  is shown in Fig. 2.  $\alpha$  is known to depend on the emitter current  $I_E$ ; thus,  $V_\alpha$  is a function of  $I_E$ . This is important in the interpretation of  $V_\alpha$  measurements.

For the discussion of static characteristics, the average or dc  $\alpha$  must be used; it is given by

$$\bar{\alpha} = \frac{1}{I_E} \int_0^{I_E} \alpha(I_E) dI_E. \tag{4}$$

Fig. 3 shows qualitatively the low voltage values  $\alpha_0$  and  $\bar{\alpha}_0$  as functions of  $I_E$ . Analogous to the definition of  $V_\alpha$ ,  $V_{\bar{\alpha}}$  is defined as the collector voltage at which  $\bar{\alpha} = 1$ .

The space-charge layer variation with collector voltage introduces another dependence of  $\alpha$  on collector voltage. In addition, if the base region is very narrow,

In terms of the ionization rate  $a_i$ , the condition for avalanche breakdown is

$$\int_0^{x_m} a_i(E) dx = 1, \tag{1}$$

where  $x_m$  is the width of the space-charge layer and  $E$  is the electric field. On the average, one charge carrier ionizes once in passing through the space-charge layer. Each hole creates on the average one electron-hole pair and that electron in turn creates another electron-hole pair if the ionization rates of electron and hole are equal. Thus, another hole is available; the mechanism sustains itself, and a true breakdown occurs. The dependence of  $a_i$  on  $E$  is a property of the semiconductor.<sup>4,6</sup>

Experimental evidence<sup>7</sup> indicates that when the space-charge region is extremely narrow, Zener breakdown does occur. For such narrow space-charge regions, (1) is not satisfied at the breakdown voltage. The field in

<sup>6</sup> P. A. Wolff, “Theory of electron multiplication in silicon and germanium,” *Phys. Rev.*, vol. 95, pp. 1415-1420; September, 1954.

<sup>7</sup> K. B. McAfee, E. J. Ryder, W. Shockley, and M. Sparks, “Observation of Zener current in germanium *p-n* junctions,” *Phys. Rev.*, vol. 83, pp. 650-651; August, 1951.

<sup>8</sup> J. M. Early, “Design theory of junction transistors,” *Bell Sys. Tech. Jour.*, vol. 32, pp. 1271-1312; November, 1953.

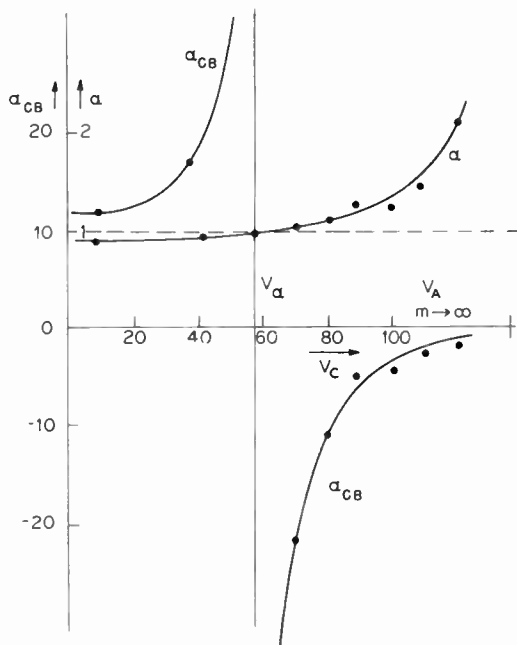

Fig. 2—Measured values of  $\alpha$  and  $\alpha_{cB}$  vs  $V_c$ .

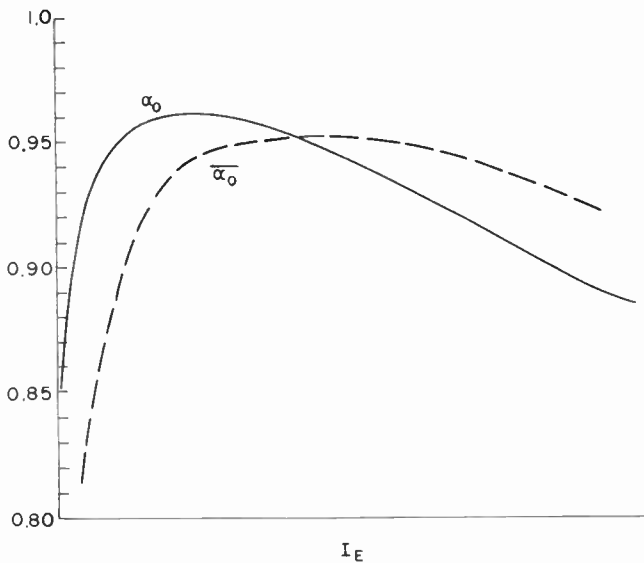

Fig. 3—Low voltage values of  $\alpha$  and  $\bar{\alpha}$  vs emitter current.

the effect called punch-through may occur at collector voltages smaller than the avalanche breakdown voltage.<sup>1</sup> Under this condition,  $\alpha$  equals unity; there is no transistor action since the base potential can no longer control the emitter current (which becomes destructively high unless externally limited). In the design of junction transistors with  $\alpha > 1$ , the occurrence of punch-through must be avoided. This is done by choosing the minimum base width and the semiconductor resistivity such that the punch-through voltage is higher than the avalanche breakdown voltage.

**ELECTRICAL CHARACTERISTICS**

In the  $\alpha > 1$  region, the electrical characteristics of junction transistors are basically similar to those of the

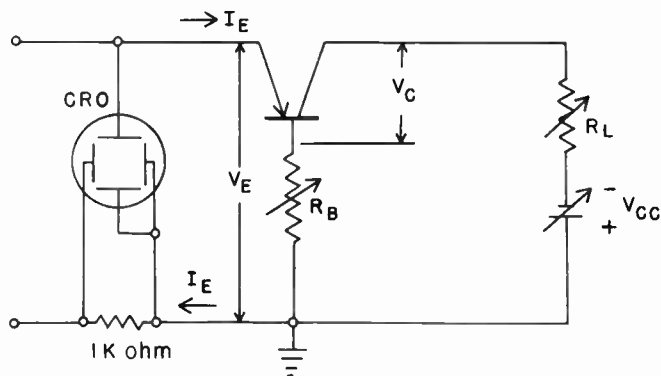

Fig. 4—Circuit to display the  $I_E, V_E$  characteristic.

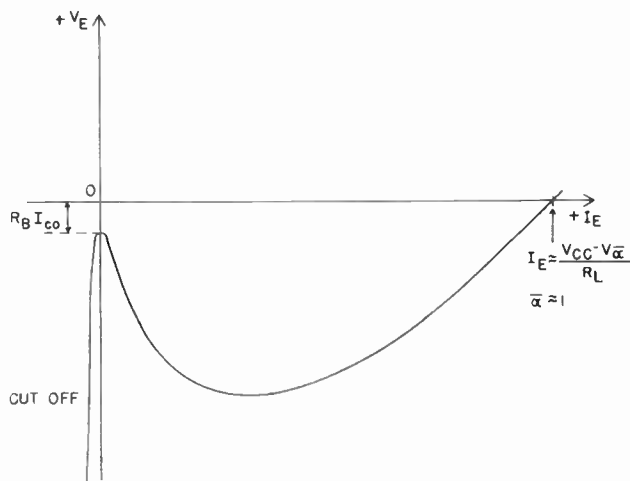

Fig. 5— $-I_E, V_E$  characteristic for  $V_c (I_E=0) > V_{\bar{\alpha}}$ .

point-contact type. Some particularly interesting features arise from the possibility of varying  $\alpha$  from greater than to less than unity; special attention is needed when  $\alpha = 1$ .

*Emitter Characteristic*

The current-voltage characteristic  $V_E, I_E$  of the circuit shown in Fig. 4 will be called the emitter characteristic. It can be displayed on an oscilloscope as shown in Fig. 4. If the collector voltage for  $I_E=0$  exceeds  $V_{\bar{\alpha}}$ , an N curve results as illustrated in Fig. 5. The shape of this curve depends upon the various transistor parameters and the external base resistor  $R_B$ , the load resistor  $R_L$ , and the voltage of the battery  $V_{cc}$  in the collector circuit. In general, the curve can be constructed only graphically from curves representing  $m$  as a function of collector voltage and  $\alpha_0$  as a function of emitter current. The slopes in the various regions can be calculated. The only quantity of interest in a later discussion is the point where the  $V_E, I_E$  curve intersects the  $I_E$  axis. As will be shown there, this point corresponds to  $\bar{\alpha} \approx 1$  and  $I_E \approx (V_{cc} - V_{\bar{\alpha}})/R_L$ .

*Collector Characteristic*

The collector characteristic for a constant emitter current shows implicitly the increase of  $\bar{\alpha}$  to values

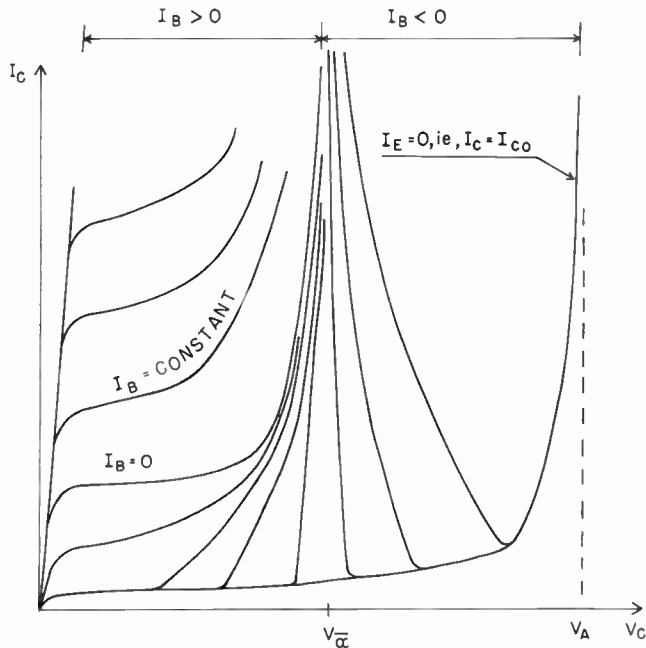

Fig. 6— $I_c, V_c$  characteristic for constant  $I_B$ .

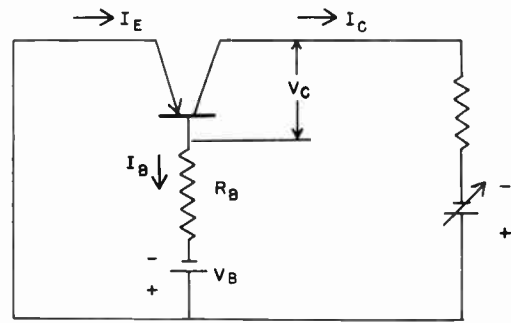

Fig. 7—Circuit for measuring the collector characteristic with constant  $I_B$ .

Measurements were made with the circuit shown in Fig. 7. (The characteristics are shown in Fig. 6.) The curves for  $I_B=0$  and  $I_B>0$  are well known. Since the numerator in (8) is always positive for  $I_B \geq 0$ ,  $I_c$  approaches infinity when  $\bar{\alpha}$  approaches one; i.e., when  $V_c$  increases toward  $V_{\bar{\alpha}}$ . For a forward biased emitter, the emitter junction voltage is small and  $I_B = V_B/R_B$ . This is the case for the polarity of  $V_B$  shown in Fig. 7. For negative  $V_B$  (opposite polarity),  $I_B$  is negative and the emitter is biased in the reverse direction as long as

$$|I_B R_B| < |V_B|. \tag{9}$$

Under this condition,  $I_B$  is not yet stabilized and equals  $I_{co} + I_{Eo}$ , where  $I_{Eo}$  is the cutoff current for the emitter.<sup>10</sup>  $I_c$  equals  $I_{co}$  as seen from Fig. 6 where, in the  $I_B < 0$  region, the curves (with one exception) coincide at low  $V_c$  with the  $I_{co}$  curve. (For the exception,  $V_B$  and  $R_B$  are such that  $|I_c| > |V_B|/R_B$  as soon as the collector reverse current saturates.)  $I_{co}$  and consequently  $|I_B R_B|$  increase with  $V_c$ . At a certain  $V_c$  the voltage drop  $|I_B R_B|$  is equal to or slightly greater than  $|V_B|$ ; under this condition, the emitter is biased in the forward direction.  $I_E$  and  $I_c$  then increase strongly with changing  $V_c$ , while  $I_B$  stays at the value  $V_B/R_B$ . It should be mentioned that (5) and thus (8) only hold for forward biased emitters. As long as the emitter is biased in reverse,  $V_c$  can exceed  $V_{\bar{\alpha}}$  without causing any singularity in  $I_c$ .

The strong increase of  $I_c$  occurs with positive or negative differential resistance, depending on whether the critical  $V_c$  for which the emitter action starts is smaller or larger than  $V_{\bar{\alpha}}$ . This can easily be seen from a discussion of the derivative  $dI_c/dV_c$ . From (6),

$$I_{co}' = m'I_S + I_L', \tag{10}$$

where the primes designate derivatives with respect to  $V_c$ . No specific equation will be used for  $m$ . However, the fact that  $m' > 0$  (Fig. 1) will be used. A possible dependence of  $m$  on current is neglected. Here, the variation of  $\alpha$  with  $I_E$  is also neglected; whereas, in the following section the influence of this dependence on the

greater than unity for increasing collector voltage.  $V_{\bar{\alpha}}$  varies with  $I_E$  due to the dependence of  $\alpha$  on  $I_E$ .  $I_c$  shows a rapid increase when  $V_c$  approaches  $V_A$ .

Of more interest is the  $I_c, V_c$  characteristic with constant base current. It has been shown<sup>1</sup> that for positive base currents  $I_c$  becomes infinitely large when  $V_c$  approaches  $V_{\bar{\alpha}}$ . The  $I_c, V_c$  characteristic including the region of negative base currents has also been discussed elsewhere.<sup>9</sup> A more detailed discussion, especially of the condition for positive and negative resistance and of the influence of the  $\alpha$  vs  $I_E$  variation, is presented here.

The collector current with forward biased emitter is given by

$$I_c = \bar{\alpha} I_E + I_{co}. \tag{5}$$

$\bar{\alpha}$  is the average  $\alpha$  as defined in (1).

$$I_{co} = m I_S + I_L \tag{6}$$

is the cutoff current, where  $I_S$  and  $I_L$  are saturation and leakage current, respectively. The leakage current in general will depend on collector voltage  $V_c$ .

For the  $I_c, V_c$  characteristic with constant  $I_B$ , it is convenient to express  $I_c$  in terms of  $I_B$ . Since the transistor does not act as a sink or source of current,

$$I_E = I_c + I_B. \tag{7}$$

Thus, with (5)

$$I_c = \frac{I_{co} + \bar{\alpha} I_B}{1 - \bar{\alpha}}. \tag{8}$$

<sup>9</sup> M. C. Kidd, W. Hasenberg and W. Webster, "Delayed collector conduction, a new effect in junction transistors," *RCA Rev.*, vol. 16, pp. 16-33; March, 1955.

<sup>10</sup> In alloyed transistors with negligible leakage,  $I_{co}$  is smaller with reverse biased emitter than with  $I_E=0$  because some of the thermally generated carriers in the base flow as  $I_{Eo}$ .

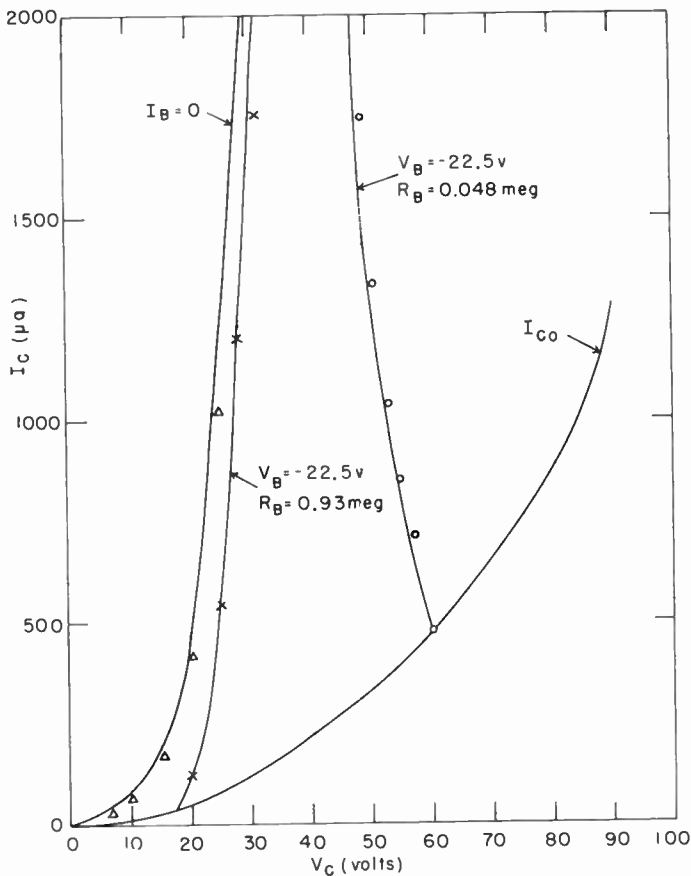

Fig. 8—Measured  $I_c$ ,  $V_c$  characteristic (curves) and calculated points for a germanium  $p-n-p$  alloyed transistor.

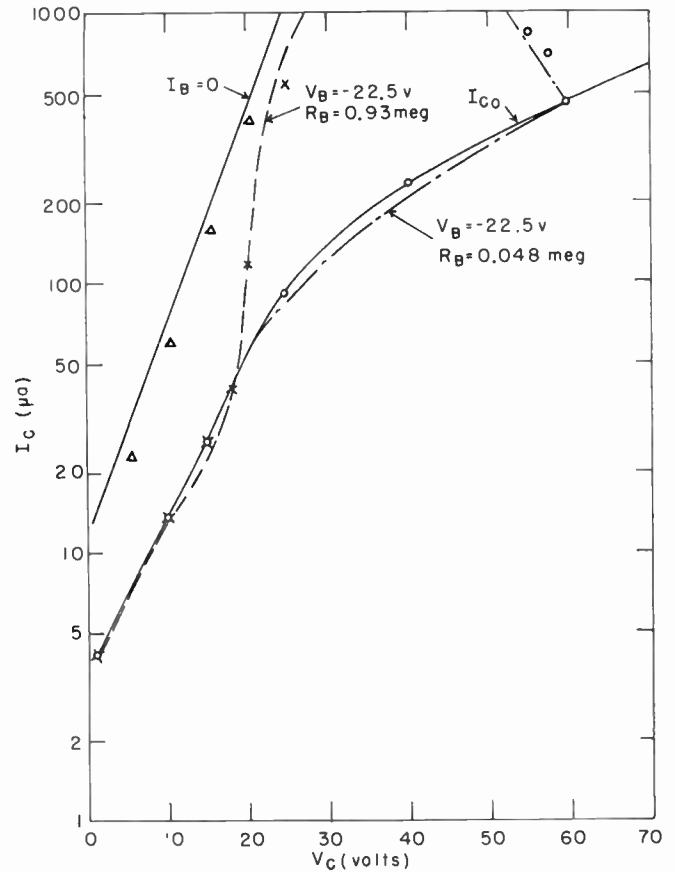

Fig. 9—Detail of Fig. 8.

characteristic will be specifically discussed. Furthermore, the space-charge layer widening is assumed negligible, so that the only voltage dependence of  $\alpha$  comes from  $m(V_c)$ . Thus,

$$\bar{\alpha}' = \bar{\alpha}_0 m', \tag{11}$$

where  $\bar{\alpha}_0 = \overline{\gamma\beta\alpha^*}$  is the average low voltage  $\alpha$ . Differentiating (8) and using (6), (10), and (11),

$$I_c' = \frac{m'I_S + \bar{\alpha}_0 m' I_L + \bar{\alpha}_0 m' I_B}{(1 - \bar{\alpha})^2} + \frac{I_L'}{1 - \bar{\alpha}}, \tag{12}$$

which can be written as

$$I_c' = \frac{m'}{m} \left( \frac{I_c - I_L}{1 - \bar{\alpha}} \right) + \frac{I_L'}{1 - \bar{\alpha}}. \tag{13}$$

It is an experimental fact that the leakage current increases with voltage; *i.e.*,  $I_L' > 0$ . Since  $m'$  and  $I_c - I_L (= mI_S + \bar{\alpha}I_E)$  are also positive,

$$\left. \begin{aligned} I_c' > 0, & \text{ when } \bar{\alpha} < 1, \text{ i.e., } V_c < V_{\bar{\alpha}} \\ I_c' < 0, & \text{ when } \bar{\alpha} > 1, \text{ i.e., } V_c > V_{\bar{\alpha}} \end{aligned} \right\} \tag{14}$$

Therefore, summarizing for  $I_B > 0$ ,  $V_c$  is smaller than  $V_{\bar{\alpha}}$ ; thus  $I_c' > 0$ . For  $I_B < 0$ ,  $I_c'$  is positive or negative depending on whether the emitter action starts at a collector voltage smaller or larger than  $V_{\bar{\alpha}}$ . This is deter-

mined by the values of  $V_B$ ,  $R_B$ , and  $I_{co}$ . The condition for positive or negative differential resistance is not influenced by the values of  $I_L$  and  $I_L'$ ; they only affect the magnitude of the resistance.

Fig. 8 shows measured  $I_c$ ,  $V_c$  curves and calculated points for an alloyed  $p-n-p$  germanium transistor. The measurements were made dc-wise, and the calculated values obtained in the following way: For  $I_E > 0$  (emitter biased forward),  $I_B$  equals the constant value  $V_B/R_B$ .  $I_{co}(V_c)$ ,  $V_A$ , and  $\alpha_0(I_E)$  are measured; and these give  $m(V_c)$  and  $\bar{\alpha}_0(I_E)$ ; thus,  $\bar{\alpha}(I_E, V_c)$ . At any  $I_c$  there is one  $V_c$  for which (5) is satisfied under condition (7). The agreement between the calculated values and measurements is good. Condition (14) for positive or negative resistance is fulfilled, and the requirement that  $I_B = V_B/R_B$  for the beginning of emitter action checks satisfactorily. Notice that this transistor had a high  $I_L$ . Fig. 9 shows on a semilog plot the lower half of Fig. 8. For a reverse biased emitter,  $I_c$  is expected to equal  $I_{co}$  since  $I_L$  is high; thus, the calculated points lie on the  $I_{co}$  curve. Deviations are due to inaccuracies in the experiment.

From measured  $I_c$ ,  $V_c$  curves and measured  $V_A$  and  $\alpha_0(I_E)$ , all the quantities in (13) can be obtained.  $I_c'$  was calculated from (13) for two curves in Fig. 8 and compared in Table I with values measured from the  $I_c$ ,  $V_c$  curves. The agreement is not good because of errors in



TABLE I

	$R_B = 48 \text{ k}$			$R_B = 0.93 \text{ meg}$		
	$I_c = 700 \mu\text{a}$	$1,000 \mu\text{a}$	$1,500 \mu\text{a}$	$I_c = 100 \mu\text{a}$	$700 \mu\text{a}$	$1,500 \mu\text{a}$
$I_c'$ calculated ( $\mu\text{a/v}$ )	-48	-75	-128	35	90	150
$I_c'$ measured ( $\mu\text{a/v}$ )	-54	-128	-166	55	140	280

the measurement of  $V_c$ . Better agreement should be obtained in a comparison of the calculated  $I_c'$  and the measured ac conductance.

It is apparent from Table I that the output impedance of a junction transistor in the region of constant negative  $I_B$  is much lower than in the normal  $I_B > 0$  region. Fig. 6 shows that extremely low values of output impedance can easily be obtained by proper choice of the stabilized  $I_B$ . Since any bulk resistance in series with the junction can be compensated by a negative junction resistance, these values of the output impedance can be even lower than in the collector breakdown region.

#### Negative Resistance in a Two-Terminal Device

In general,  $\alpha$  varies with  $I_E$  as shown in Fig. 3. Deviations are therefore expected from the collector characteristics shown in Fig. 6. In Fig. 10 the collector characteristic for a typical transistor having a strong variation of  $\alpha$  with  $I_E$  is shown. Here the curves for positive and zero base current show negative resistance regions. In the quantitative discussion below it will be shown that in these current regions  $d\bar{\alpha}/dI_E$  must be positive and exceed a certain value. As soon as the current is high enough so that  $\bar{\alpha}$  decreases again with  $I_E$ , a positive resistance is found. For large positive  $I_B$ , no negative resistance is observed. In such a case, for the given  $I_B$ , the corresponding  $I_E$  is already so high that  $d\bar{\alpha}/dI_E$  is negative (see Fig. 3). For this reason in many alloyed transistors, for  $I_B > 0$  and even for the curve with  $I_B = 0$ , no negative resistance is observed. However, frequently, negative resistance is observed when the transistor is operated in the reverse direction; *i.e.*, when emitter and collector are interchanged. To see this, consider the "collector current" for  $I_B = 0$ . From (8) this is  $I_{E0}/(1 - \bar{\alpha}_{Ec})$ . Normally  $I_{E0}$  is smaller than  $I_{c0}$ , also  $\bar{\alpha}_{Ec}$  is smaller than the corresponding quantity  $\bar{\alpha}_{cE}$  for the normal direction and finally  $\bar{\alpha}_{Ec}$  often has its maximum at higher currents than  $\bar{\alpha}_{cE}$ .

Since  $I_B = 0$ , the base is disconnected and the result is a two-terminal device with a nonthermal negative resistance. Such a device serves as an oscillator and also an amplifier.<sup>11</sup> No connection to the base region is needed; very narrow base regions and good high frequency response can be obtained easily. Substantial simplifications in circuitry are possible; this is especially important in computer applications. For example, the

circuit of Fig. 7 used the battery  $V_B$  to obtain the negative resistance in Fig. 6; no such battery is needed with a two-terminal negative resistance device.

A diode relaxation oscillator using a transistor with an open base and a negative resistance due to  $\partial\bar{\alpha}/\partial I_E > 0$  has been built with satisfactory operation. Across a load of 200 ohms the peak current was 0.1 ampere with a rise time of less than 0.1 microsecond at a repetition rate of 5 kc. Quantitatively the differential resistance  $I_c'$  is obtained from (7) and (8):

$$I_c' \left\{ 1 - \frac{I_E \frac{\partial \bar{\alpha}}{\partial I_E}}{1 - \bar{\alpha}} \right\} = \frac{\frac{\partial I_{c0}}{\partial V_c} + I_E \frac{\partial \bar{\alpha}}{\partial V_c}}{1 - \bar{\alpha}} \quad (15)$$

In many transistors it is a good approximation to neglect the space-charge layer widening and attribute the entire voltage dependence of  $\alpha$  to the variation of  $m$  with  $V_c$ . Thus,

$$\frac{\partial \bar{\alpha}}{\partial V_c} = \bar{\alpha}_0 \frac{\partial m}{\partial V_c} \quad (16)$$

For the current dependence of  $\bar{\alpha}$ , satisfactory agreement was obtained between measurements and theory if  $m$  is assumed to be independent of current. Therefore, let

$$\frac{\partial \bar{\alpha}}{\partial I} = m \frac{\partial \bar{\alpha}_0}{\partial I} \quad (17)$$

From (16) and (17), (15) becomes

$$I_c' \left\{ 1 - \frac{I_E \frac{\partial \bar{\alpha}}{\partial I_E}}{1 - \bar{\alpha}} \right\} = \frac{m'}{m} \left( \frac{I_c - I_L}{1 - \bar{\alpha}} \right) + \frac{I_L'}{1 - \bar{\alpha}}, \quad (18)$$

where the primes again designate derivatives with respect to  $V_c$ . The right-hand side of (18) is obviously positive for  $\bar{\alpha} < 1$  and negative for  $\bar{\alpha} > 1$ .

The conditions for positive or negative  $I_c'$  are easily found from (18). For the curves to be considered, the emitter is biased in the forward direction, thus,  $I_E > 0$  and the following conclusions can be drawn:

1. If  $\bar{\alpha} < 1$  and  $\partial\bar{\alpha}/\partial I_E < 0$ ,

$$\text{then } I_c' \left\{ 1 - \frac{I_E \frac{\partial \bar{\alpha}}{\partial I_E}}{1 - \bar{\alpha}} \right\} > 0; \text{ thus } I_c' > 0.$$

<sup>11</sup> W. Shockley and W. P. Mason, "Dissected amplifiers using negative resistance," *Jour. Appl. Phys.*, vol. 25, p. 677; May, 1954.

2. If  $\bar{\alpha} < 1$  and  $\partial\bar{\alpha}/\partial I_E > 0$ ,

$$\text{then } I_c' \left\{ 1 - \frac{I_E \frac{\partial\bar{\alpha}}{\partial I_E}}{1 - \bar{\alpha}} \right\} > 0,$$

$$\text{and for } \frac{1}{I_E} > \frac{\frac{\partial\bar{\alpha}}{\partial I_E}}{1 - \bar{\alpha}}, \quad I_c' > 0;$$

$$\text{for } \frac{1}{I_E} < \frac{\frac{\partial\bar{\alpha}}{\partial I_E}}{1 - \bar{\alpha}}, \quad I_c' < 0.$$

3. If  $\bar{\alpha} > 1$  and  $\partial\bar{\alpha}/\partial I_E < 0$ ,

$$\text{then } I_c' \left\{ 1 - \frac{I_E \frac{\partial\bar{\alpha}}{\partial I_E}}{1 - \bar{\alpha}} \right\} < 0,$$

$$\text{and for } \frac{1}{I_E} > \frac{\frac{\partial\bar{\alpha}}{\partial I_E}}{1 - \bar{\alpha}}, \quad I_c' < 0;$$

$$\text{for } \frac{1}{I_E} < \frac{\frac{\partial\bar{\alpha}}{\partial I_E}}{1 - \bar{\alpha}}, \quad I_c' > 0.$$

4. If  $\bar{\alpha} > 1$  and  $\partial\bar{\alpha}/\partial I_E > 0$ ,

$$\text{then } I_c' \left\{ 1 - \frac{I_E \frac{\partial\bar{\alpha}}{\partial I_E}}{1 - \bar{\alpha}} \right\} < 0; \quad \text{thus } I_c' < 0.$$

For the emitter biased in the reverse direction,  $I_c'$  is obviously always positive.

$$I_c' = m'I_S + I_L' = I_{co}'. \quad (19)$$

With these conditions, the behavior of the characteristics in Fig. 10 can be discussed in detail. Consider the dashed curve. At the low end, the emitter is cut off,  $I_c' = I_{co}'$ . Emission starts in the  $\alpha < 1$  region at a relatively low current where  $\partial\bar{\alpha}/\partial I_E > 0$ . Thus, case 2 applies. At low  $I_E$  the first condition is fulfilled and  $I_c'$  is positive; at higher  $I_E$  the second condition exists,  $I_c'$  is negative. With further increasing current  $\partial\bar{\alpha}/\partial I_E$  becomes negative and, according to case 1,  $I_c' > 0$ .

For  $I_B = 0$ , (18) is conveniently rewritten as

$$I_c' \left\{ 1 - \frac{I_c'^2}{I_{co}'} \frac{\partial\bar{\alpha}}{\partial I_E} \right\} > 0. \quad (20)$$

Thus,

$$I_c' > 0 \quad \text{for} \quad \frac{I_{co}'}{I_c'^2} > \frac{\partial\bar{\alpha}}{\partial I_E};$$

$$I_c' < 0 \quad \text{for} \quad \frac{I_{co}'}{I_c'^2} < \frac{\partial\bar{\alpha}}{\partial I_E}.$$

When  $I_L$  is negligible, the conditions simplify:

$$I_c' \geq 0 \quad \text{for} \quad \frac{I_S}{I_c'^2} \geq \frac{\partial\bar{\alpha}_0}{\partial I_E}.$$

From measured  $I_S$  and  $\alpha_0(I_E)$  the  $I_c$  region in which the resistance is negative can be calculated.

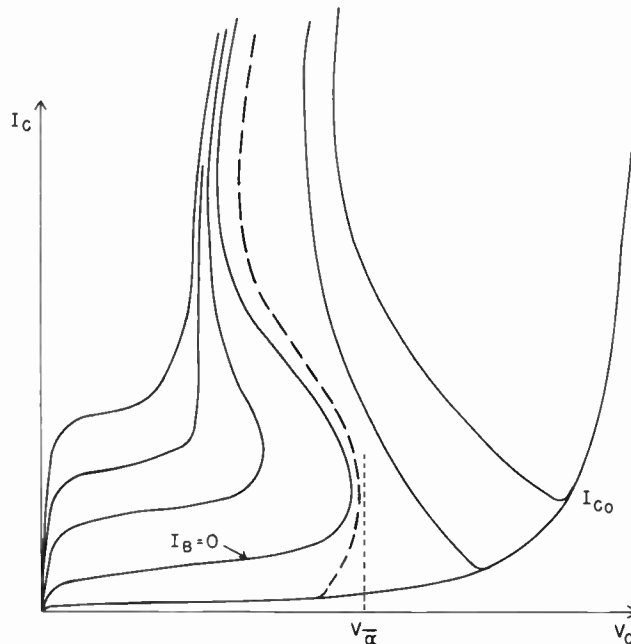

Fig. 10— $I_c$ ,  $V_c$  characteristic for a junction transistor whose  $\alpha$  vs  $I_E$  variation accounts for negative resistance in  $\bar{\alpha} < 1$  region.

Fig. 11 shows measured collector characteristics with  $I_B \leq 0$  for an alloyed  $p-n-p$  germanium transistor. Negative resistance at  $\bar{\alpha} < 1$  due to  $\alpha(I_E)$  was observed. There is good agreement between measured and calculated values.

### High Frequency Operation and Transients

In this section the behavior of the  $\alpha$ -cutoff frequency in the region with  $m > 1$  is mainly considered.

As is well known, the  $\alpha$ -cutoff frequency  $f_{\alpha 0}$  of the low voltage  $\alpha$  is given by<sup>12</sup>

$$f_{\alpha 0} = \frac{1.2}{\pi} \frac{D}{w^2}, \quad (21)$$

where  $D$  is the diffusion constant for the minority carriers in the base, and  $w$  is the average base width. The equation is valid if the current through the base flows as diffusion current and the electric field is negligible. At high  $V_c$ , such that  $\bar{\alpha} > 1$ , three effects may influence  $f_{\alpha 0}$ . First, there may be some time delay in the current multiplication process. This delay is of the order of space-charge layer width divided by drift velocity or for a typical germanium junction, about  $5 \times 10^{-4}$  cm/ $5 \times 10^9$  cm sec<sup>-1</sup> =  $10^{-10}$  sec. Obviously, this delay does not affect the frequency response of  $\alpha$  in present-day transistors.

<sup>12</sup> R. L. Pritchard, "Frequency variations of current-amplification factor for junction transistors," PROC. IRE, vol. 40, pp. 1476-1481; November, 1952.

Secondly, the use of high  $V_c$  may give rise to substantial space-charge layer widening with a resulting increase in  $f_{\alpha_0}$ . In the preceding discussions,  $V_P$  was simply required to be larger than  $V_A$  (so that transistor action in the  $\alpha > 1$  region can take place up to  $V_A$ ); now it appears that for good high frequency operation  $V_P$  equal to (or slightly larger than)  $V_A$  is best.

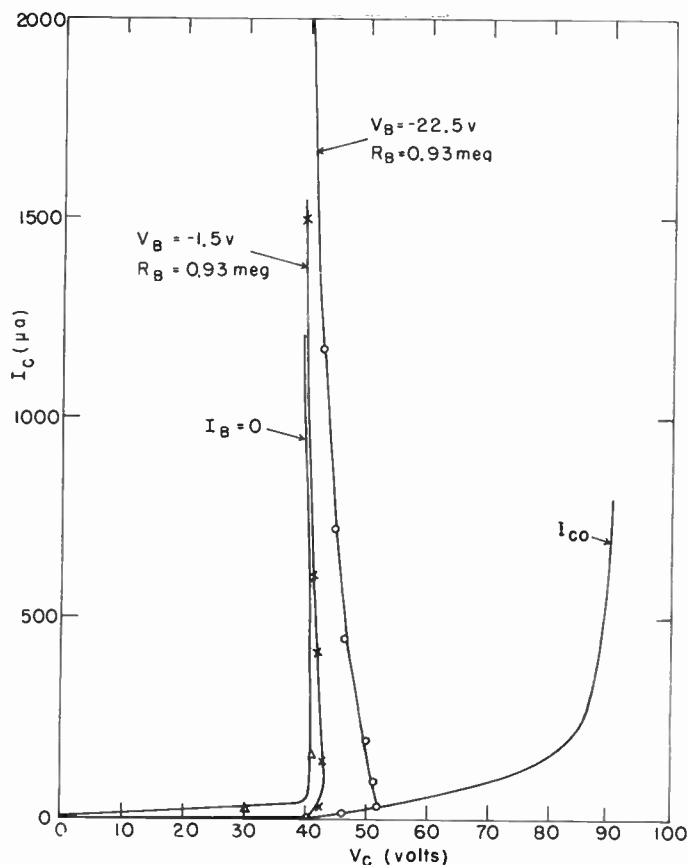

Fig. 11—Measured  $I_c$ ,  $V_c$  characteristic (curve) and calculated points for a germanium  $p-n-p$  alloyed transistor with negative resistance in the  $\alpha < 1$  region.

The third and potentially most important influence on  $f_{\alpha_0}$  arises from an electric field set up in the base region. When  $m > 1$ , a majority carrier current flows from the collector junction into the base, and since this is a drift current, an electric field  $E$  exists in the base. The field component perpendicular to the collector accelerates minority carriers diffusing toward the collector and, thus, increases  $f_{\alpha_0}$ . The geometry of the transistor, including position and shape of the base contact, affects the field distribution in the base and, thus, the influence of this field on  $f_{\alpha_0}$ . The majority carrier current is generated in the collector space-charge layer. In a  $p-n-p$  transistor, this current is an electron current  $I_n = (m-1)I_p$ , where  $I_p$  is the hole current. In order to calculate the  $\alpha$ -cutoff frequency under this condition, the field  $E$  must be known. For accurate results, this requires a study of the three-dimensional problem.

Although this can be done in principle, in practice it is necessary to limit the study to a one-dimensional geometry. This assumption will give field strengths near the emitter that are too high, while those near the collector are not too inaccurate. Therefore, although the results cannot be accurate with such a simplified geometry, they represent an upper limit for the cutoff frequency and show how large effects can be obtained for transistors approximating a one-dimensional structure.

A cross section of an idealized one-dimensional transistor is shown in Fig. 12. The emitter plane is assumed to have a checkerboard structure, the "black" squares being the emitter and the "white" squares being the base. In the limit of infinitely small squares, a true one-dimensional structure is obtained. In this way parallel flow of electrons and holes is achieved. In order to make full use of the field calculated below, the actual geometry should deviate as little as possible from this idealized structure. A ring base contact around the emitter is a possible first approximation.

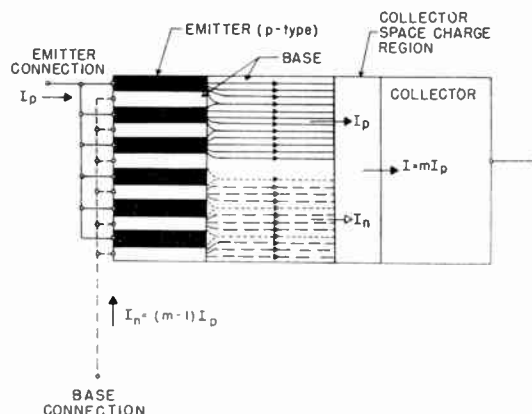

Fig. 12—Idealized transistor geometry to obtain a parallel flow of minority and majority carrier currents in the base. (For clarity, the minority carrier current is shown in the upper half only, the majority carrier current in the lower half only.)

$E(x)$  is calculated from

$$j_p = -qD_p \frac{\partial p}{\partial x} + qp\mu_p E, \tag{22}$$

$$j_n = qD_n \frac{\partial n}{\partial x} + qn\mu_n E, \tag{23}$$

where  $j_p$  and  $j_n$  are the hole and electron current densities;  $q$  is the absolute value of the electronic charge;  $\mu_p$ ,  $\mu_n$ ,  $D_p$ , and  $D_n$  are mobilities and diffusion constants for holes and electrons, respectively; and  $p$  and  $n$  are hole and electron densities. If the emitter efficiency is assumed to be unity and if recombination is neglected, then everywhere in the base region

$$j_n = (m-1)j_p. \tag{24}$$

From (22) to (24), assuming electrical neutrality in the base; *i.e.*,  $n = p + N_a$ , then

$$\frac{dp}{dx} = -\frac{j_p}{qD_p} \left\{ \frac{N_d + p \left[ 1 - (m-1) \frac{\mu_p}{\mu_n} \right]}{N_d + 2p} \right\} \quad (25)$$

and

$$E(p) = \left( \frac{m-1 + \frac{\mu_n}{\mu_p}}{q\mu_n(N_d + 2p)} \right) j_p. \quad (26)$$

Let  $c = 1 - (m-1)\mu_p/\mu_n$ ; then, the solution of (25) with the boundary condition  $p = 0$  at  $x = w$  is

$$w - x = \frac{qD_p N_d}{j_p c^2} \left[ 2c \frac{p}{N_d} - (2 - c) \ln \left( 1 + c \frac{p}{N_d} \right) \right]. \quad (27)$$

From (25) it can be seen that for negative  $c$ ,  $dp/dx = 0$  when  $p = p_{max} = -N_d/c$ . Thus,  $p(x)$  can never exceed this value. Whether a solution ever approaches this maximum value depends upon the current density  $j_p$ . The larger the value of  $j_p$  the closer  $p(x)$  approaches this limiting value. Fig. 13 shows  $p(x)$  for one given negative value of  $c$  and various values of  $j_p$ . A  $J_{p0}$  is defined for which the hole density reaches 0.9  $p_{max}$ . This critical value  $j_{p0}$  can be calculated from (27) by setting  $x = 0$  and  $p = 0.9 p_{max}$ .

$$j_{p0} = \frac{qD_p N_d}{w} \left( \frac{2.8 - 2.3c}{c^2} \right). \quad (28)$$

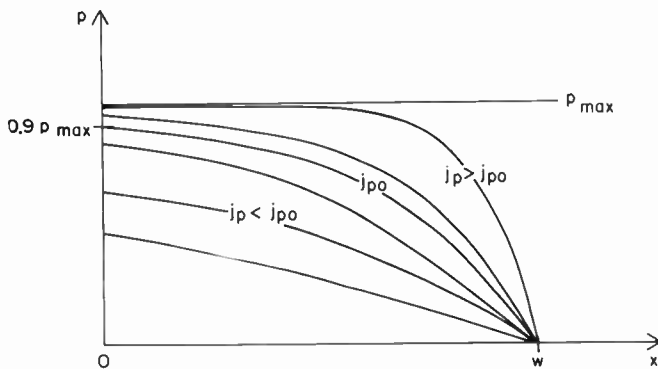

Fig. 13—Solution  $p(x)$  for one value of  $c < 0$  and various values  $j_p$ .

For example, in germanium  $\mu_n/\mu_p = 2$ ; assuming  $m = 5$ ,  $N_d = 10^{15} \text{ cm}^{-3}$  and  $w = 2.5 \times 10^{-3} \text{ cm}$ , one obtains  $j_{p0} = 14 \text{ amp/cm}^2$ . This current density is greater than  $j_p$  for normal small-signal applications but is exceeded in many multivibrator circuits. For current densities larger than  $j_{p0}$  it may be considered a reasonable approximation to set the hole density in the entire base equal to  $p_{max}$ . Then  $E$  becomes a constant

$$E = \frac{kT}{q} \frac{j_p}{qD_p p_{max}} \quad (j_p \gg j_{p0} \text{ and } c < 0). \quad (29)$$

The cutoff frequency  $f_\alpha$  has been obtained for the case  $E(x) = \text{constant}$ .<sup>13</sup> In Fig. 14 the ratio of the cutoff frequency  $f_\alpha$  with field and  $f_{\alpha 0}$  without field is plotted vs a suitably normalized electric field.

Consider the following example. Assume again, as above,  $\mu_n/\mu_p = 2$ ,  $m = 5$ ,  $N_d = 10^{15} \text{ cm}^{-3}$ ,  $w = 2.5 \times 10^{-3} \text{ cm}$ ; take a current density  $j_p = 100 \text{ amp/cm}^2$ . This corresponds to total current density  $m j_p = 500 \text{ amp/cm}^2$ , a value which is close to the highest current densities achieved so far in pulse operation. For a one-dimensional geometry a sixtyfold increase in cutoff frequency is expected.

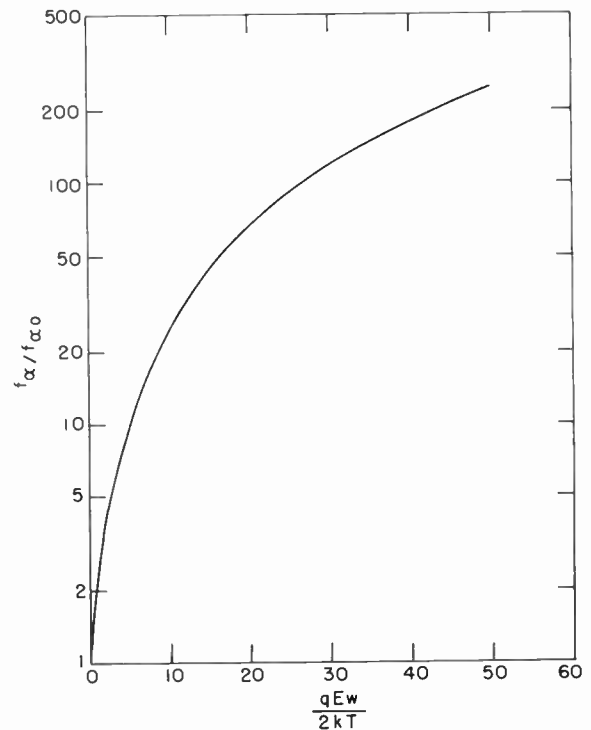

Fig. 14—Ratio of the  $\alpha$ -cutoff frequency with an electric field in the base and the  $\alpha$ -cutoff frequency for the diffusion mechanism as a function of the electric field which is assumed constant throughout the base region.

For the special case  $c = 0$ , simple formulas may be obtained. Eq. (27) reduces to

$$p(x) = N_d \frac{-1 + \sqrt{1 + 4 \frac{j_p}{qD_p N_d} (w - x)}}{2}, \quad (30)$$

and with (26),

$$E(x) = \frac{2kT}{qw} \frac{\delta}{\sqrt{1 + 4\delta \left( 1 - \frac{x}{w} \right)}}, \quad (31)$$

<sup>13</sup> H. Statz, W. Leverton, and J. Spanos, paper presented at the IRE-AIEE Semiconductor Device Research Conference, Philadelphia, Pa.; June, 1955.

where

$$\delta = \frac{j_p w}{qD_p N_d} \tag{32}$$

Fig. 15 shows  $qEw/2kT$  as a function of  $\delta$  at different positions  $x/w$  in the base. At large current densities the field is strong, thus the frequency response is improved. For  $\delta > 0.5$ ,  $E$  is substantially less at the emitter than at the collector, even for the one-dimensional geometry. Since the field is not constant, Fig. 14 does not apply. However, an upper limit for  $f_\alpha$  can be obtained with  $E(x=w)$ , since  $E(x < w) < E(x=w)$ . Consider for example a germanium transistor with  $w = 2.5 \times 10^{-3}$  cm and  $N_d = 10^{15}$  cm<sup>-3</sup>. The value of  $V_c$  is such that  $m = (\mu_n/\mu_p) + 1 \approx 3$ ; i.e.,  $c = 0$ . For  $j_p = 0.5$  amp/cm<sup>2</sup> and a total current density  $j = 1.5$  amp/cm<sup>2</sup>, the value for  $\delta$  is 0.18.

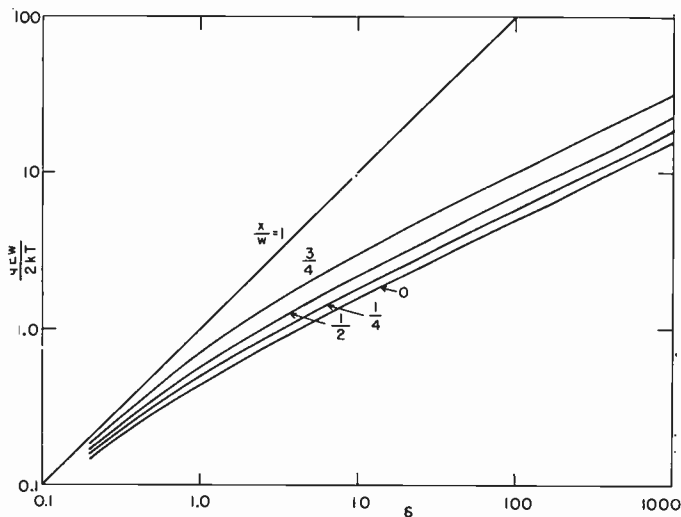

Fig. 15—Normalized electric field at various positions in the base as a function of the normalized current density  $\delta$  for the special case  $m = (\mu_n/\mu_p) + 1$ .

From Figs. 14 and 15 one can therefore conclude that there is practically no increase in cut off frequency. If the current density is  $j_p = 100$  amp/cm<sup>2</sup>, an improvement in cut off frequency results, with an upper limit  $f_\alpha = 60 f_{\alpha 0}$ .

It may be possible in the future to construct special transistors which will make full use of this electric field.

For high frequency operation, the effect of the collector capacity  $C_c$  is also of great interest.  $C_c$  provides a conductance in parallel with the junction resistance and for a given  $V_c$ , the capacitive current increases with frequency. This changes the  $I_c, V_c$  characteristics of Figs. 6 and 10. Not only do the curves form loops, but the negative resistance regions may disappear completely. While with low frequencies at a certain  $V_c$ , the emitter may still be cut off (and with increasing  $V_c$  a negative resistance region appears), with high frequencies the capacitive current can bias the emitter in the forward direction due to the voltage drop across  $R_B$ .

Since this current leads  $V_c$  by  $\pi/2$ , the effect is more pronounced. Decreasing  $R_B$  increases the value of  $V_c$  at which the emitter action starts and thus increases the frequency range for negative resistance. However, lowering  $R_B$  increases the capacitive current, and the loops in the  $I_c$  vs  $V_c$  curves become wider.

AN APPLICATION

The circuit of Fig. 16 has been used to study the performance of junction transistors with  $\alpha > 1$ . This circuit is a simple free-running blocking oscillator whose operation has been described for point-contact transistors.<sup>14</sup> In this circuit, germanium and silicon alloyed and grown junction, and  $p-n-p$  as well as  $n-p-n$  transistors have been used successfully. The base resistivities ranged from 0.02 to 10 ohm cm in germanium transistors, and from 4 to 10 ohm cm in silicon units. This means that in all these cases, charge-carrier multiplication in the space-charge layer occurred and the junction breakdown was the avalanche and not the Zener type.

The most important operating parameters of the blocking oscillator are the peak  $I_c$ , the rise time  $\tau$  for this current (from 10 per cent to 90 per cent of  $I_{cpeak}$ ), the pulse length  $L$  (from 10 per cent to 10 per cent of  $I_{cpeak}$ ), and the repetition frequency  $f_{rep}$ .

$I_{cpeak}$  is determined by the intersection of the  $V_E, I_E$  curve of Fig. 5 and a line parallel to the current axis through the peak point of the  $I_E$  vs  $V_E$  curve. More quantitatively, the peak in the  $V_E, I_E$  curve occurs very near the point  $I_E = 0$  and  $V_E = 0$ .  $V_E$  for large  $I_E$  is again zero when the voltage drop across the base resistor  $R_B I_E (1 - \alpha) \approx 0$ , or when  $\alpha \approx 1$ . But by definition  $\alpha$  equals unity when the voltage across the collector junction equals  $V_\alpha$ . At the peak emitter current, therefore, the difference between the battery voltage  $V_{cc}$  and  $V_\alpha$  drops

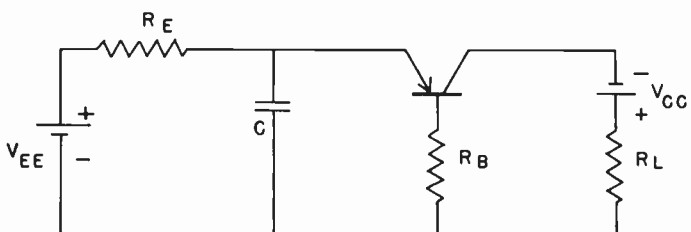

Fig. 16—Free running blocking oscillator circuit using one junction transistor and no transformer.

in the load resistor  $R_L$ ; i.e.,  $V_{cc} - V_\alpha = R_L I_E$ . Therefore, in order to make  $I_E$  large,  $R_L$  must be as small as possible and  $V_{cc} - V_\alpha$  as large as possible. Since  $V_{cc}$  should not exceed the avalanche breakdown voltage  $V_A$ , a transistor designed for high  $I_E$  peak currents must have a large difference between  $V_A$  and  $V_\alpha$ . The pulse length  $L$  is

<sup>14</sup> J. H. Felker, "Regenerative amplifier for digital computer applications," Proc. IRE, vol. 40, pp. 1584-1596; November, 1952; A. W. Lo, "Transistor trigger circuits," Proc. IRE, vol. 40, pp. 1531-1541; November, 1952; A. E. Anderson, "Transistors in switching circuits," Proc. IRE, vol. 40, pp. 1541-1558; November, 1952.

TABLE II  
OPERATING PARAMETERS OBTAINED EXPERIMENTALLY WITH THE BLOCKING OSCILLATOR OF FIG. 16

Case No.	Semi-conductor	Type of Transistor	$I_{c\text{peak}}$ (amp)	$\tau$ ( $\mu\text{sec}$ )	$L$ ( $\mu\text{sec}$ )	$f_{\text{rep}}$ (cps)	$V_{cc}$ (volt)
1a	Ge	alloyed, $p-n-p$	1.7	0.1	1	$3.0 \times 10^2$	67.5
1b	Ge	alloyed, $p-n-p$	3.5	0.25	4	$3.0 \times 10$	67.5
2	Ge	alloyed, $p-n-p$	6.0	0.2	1	$3.4 \times 10$	90
3a	Ge	alloyed, $p-n-p$	4.8	0.4	17	$1.2 \times 10$	83
3b	Ge	alloyed, $p-n-p$	0.2	0.12	0.5	$1.0 \times 10^5$	67
4	Ge	alloyed, $p-n-p$	0.002	0.04	0.1	$3.3 \times 10^6$	14
5	Ge	alloyed, $p-n-p$	0.15	0.2	0.5	$1.0 \times 10^4$	10
6a	Si	alloyed, $p-n-p$	0.02	1.0	9	$2.0 \times 10^3$	112.5
6b	Si	alloyed, $p-n-p$	0.04	1.5	420	$2.0 \times 10$	112.5
7	Si	alloyed, $n-p-n$	1.0	0.5	8	$2.0 \times 10^3$	67.5
8a	Si	grown, $n-p-n$	0.5	5	85	$1.4 \times 10$	112.5
8b	Si	grown, $n-p-n$	0.2	0.2	4	$1.2 \times 10^3$	112.5

determined mainly by the value of the condenser  $C$  in Fig. 16, and  $f_{\text{rep}}$  is obtained from the time constant  $R_E C$ .

Table II shows experimental results for various cases. Case (1a) is representative of germanium alloyed  $p-n-p$  units at medium repetition rates; Case (1b) gives the results for the same unit with a larger condenser  $C$ . High pulse currents of the order of several amperes were stable and reproducible. The highest  $I_{c\text{peak}}$  obtained so far is shown in Case (2). A high pulse current with a larger pulse duration was observed in Case (3a). The same transistor [in Case (3b)] also operated at the faster repetition rate of 100 kc. With a high-frequency unit an  $f_{\text{rep}}$  of 3.3 megacycles per second was obtained [case (4)]. Many switching applications are made preferably at low supply voltages. The transistor of Case (5) had  $V_{\alpha} = 7$  volts,  $V_A = 11$  volts and could thus be operated from a 10-volt power supply. Although most of the measurements were made on germanium units, a few results on silicon units are included. It should be emphasized that the data of Table II do not represent limitations, but consist of the results obtained to date—actually without much effort to improve the circuitry. Also, no transistors have been designed specifically for the  $\alpha > 1$  operation. Such designs increase possible peak currents and easily reduce normal operating voltages.

The effect of high temperatures on the operation of transistors in the region  $\alpha > 1$  has been investigated using the circuit described above. In a general discussion of the influence of increasing temperature  $T$ , the variation of  $\alpha$ ,  $V_{\alpha}$ , and  $V_A$  with  $T$  must be considered. The reasons for the temperature dependence of  $\alpha$  are known but no simple equation has been given so far. Normally, the low voltage value  $\alpha_0(T)$  is measured for the various transistor types.  $V_A$  increases slightly<sup>4</sup> with  $T$ , and thus, for a given  $V_c$ ,  $m$  decreases somewhat with increasing  $T$ . Measurements of  $V_{\alpha}(T)$  for germanium  $p-n-p$  alloyed transistors have not shown any significant change in  $V_{\alpha}$  up to 80°C. At higher temperatures,  $\alpha$  starts to decrease rapidly;  $V_{\alpha}$  increases; and above about 105°C, the unit is no longer useful. Normal transistor operation and operation in the  $\alpha > 1$  region gradually deteriorates as the semiconductor approaches the intrinsic region.

The well known strong increase of  $I_{c0}$  with  $T$  is not important in many switching applications of junction transistors. These circuits operate fastest, as will be shown, when  $m$  is high. Therefore,  $V_c$  in the quiescent condition is made almost equal to  $V_A$ ; thus,  $I_{c0}$  is large and must be externally limited and no variation with  $T$  occurs.

Practical results for the blocking oscillator circuit are given in Table III. Although the operating parameters do change with  $T$ , the germanium transistor is useful to a temperature of about 100°C and the silicon unit to about 185°C. The silicon unit in Table III has been operated, after  $T$  was raised to 188°C for 100 hours, at 150°C without any change in the output pulse. Then, the base connection opened because the solder had melted.

Life tests on germanium units in this circuit at room temperature have been run for 1,200 hours with about 10 per cent failures due to excessive leakage. In most units,  $\alpha$  has dropped somewhat; however, the operation was substantially unaffected.

In applications of the blocking oscillator the rise time of the current pulses is especially important. An experimental investigation has been carried out using a transistor with an avalanche breakdown voltage of approximately 11.7 volts. Results of two runs are given in Table IV for various battery voltages. In the two runs the external circuit was chosen somewhat different to obtain different peak currents. The experimental values indicate that there is a decrease in rise time with increasing collector voltage.

The problem of calculating the rise times theoretically is very difficult. Professor John Linvill from Stanford University suggested in discussions and letters to the authors a "zero order" approximation to this problem and the formulas given below are essentially due to him.

First consider a simplified version of the circuit of Fig. 16. Assume that the condenser  $C$  is so large that during the rise time the emitter current pulse cannot appreciably discharge the condenser so that the voltage  $V_E$  across the condenser is constant. Furthermore, assume that the collector capacity is negligibly small. Then dur-

TABLE III  
OPERATING PARAMETERS FOR A GERMANIUM AND A SILICON  
TRANSISTOR AT VARIOUS TEMPERATURES

Germanium, alloyed, p-n-p			
T° C	I <sub>cpeak</sub> (ma)	τ (μsec)	f <sub>rep</sub> (cps)
25	300	0.2	370
50	300	0.2	370
75	250	0.22	380
92	190	0.3	475
100	108	0.4	600
102	84	0.7	700
103	42	1.0	800
25 (after cooling)	300	0.2	370
Silicon, alloyed, n-p-n			
25	80	1.0	450
75	73	1.2	550
100	65	1.5	620
130	49	1.5	700
150	42	1.7	1,300
180	31	1.8	3,800
188	27	2.0	6,000

TABLE IV  
MEASURED AND CALCULATED VALUES OF THE RISE TIME FOR  
DIFFERENT COLLECTOR VOLTAGES AND PEAK CURRENTS

τ measured (μsec)	τ calculated (μsec)	V <sub>c</sub> (volt)	I <sub>cpeak</sub> (amp)	m
0.24	0.02	11.5	0.66	9.1
0.25	0.11	10.5	0.59	2.9
0.26	0.20	9.5	0.48	2.0
0.30	0.32	8.5	0.40	1.57
0.37	0.75	7.5	0.29	1.32
0.6	1.3	6.5	0.15	1.20
0.32	0.05	11.1	0.82	4.9
0.41	0.12	10.0	0.68	2.3
0.44	0.25	9.0	0.61	1.75
0.45	0.40	8.0	0.46	1.45
0.80	1.3	6.5	0.27	1.20

$$\tau = \frac{2.3}{\omega_0(\bar{\alpha} - 1)} \tag{37}$$

ing the buildup of the current, V<sub>E</sub> is essentially equal to the voltage drop across R<sub>B</sub> plus the small voltage drop across the emitter junction which will be neglected; i.e.,

$$V_E = (I_E - I_c)R_B \tag{33}$$

Differentiation with respect to time gives

$$\frac{dI_E}{dt} = \frac{dI_c}{dt} \tag{34}$$

A first approximation of the relation between emitter current I<sub>E</sub> and collector current I<sub>c</sub> can be derived by solving the diffusion equation for minority carriers in the base region. The result is

$$p = \omega_0 \frac{-(1 + \omega_0 R_L C_c) + \sqrt{(1 + \omega_0 R_L C_c)^2 + 4\omega_0 R_L C_c(\bar{\alpha} - 1)}}{2\omega_0 R_L C_c} \tag{38}$$

$$\bar{\alpha} I_E = I_c + \frac{1}{\omega_0} \frac{dI_c}{dt} \tag{35}$$

τ has been calculated and given in column 2 of Table IV. The general trend of decreasing τ with increasing ᾱ is given correctly by the calculation; however, the calculated τ for large ᾱ and, therefore, large m are much too small. The reason for this discrepancy is believed to be mainly due to the fact that during the transient ᾱ decreases from the large value at the beginning of the pulse to approximately unity. An exact treatment considering the variation of ᾱ would lead to a nonlinear differential equation, which is not readily solved. Also, the dependence of τ on I<sub>cpeak</sub> is not borne out by (37).

It can be seen that the discrepancies do not result from neglecting the collector capacitance C<sub>c</sub> or the finite magnitude of the capacity of C. Taking into account C<sub>c</sub> only, one obtains for p

For example, in order not to change τ of (38) appreciably for f<sub>α</sub> = 2Mc and C<sub>c</sub> = 20μF, R<sub>L</sub> has to be less than 400 ohms, which for the reported measurements was certainly always fulfilled. Similarly taking into account C and setting C<sub>c</sub> = 0, one obtains two values for p:

$$p_{1,2} = \omega_0(\bar{\alpha} - 1) \frac{[\omega_0 C R_B(\bar{\alpha} - 1) - 1] \pm \sqrt{[\omega_0 C R_B(\bar{\alpha} - 1) - 1]^2 - 4\omega_0 C R_B}}{2\omega_0 C R_B(\bar{\alpha} - 1)} \tag{39}$$

In (35), ω<sub>0</sub> = 2πf<sub>α</sub>. Inserting (35) in (34), one obtains

$$\frac{d^2 I_c}{dt^2} + \omega_0(1 - \bar{\alpha}) \frac{dI_c}{dt} = 0 \tag{36}$$

Making the very inaccurate assumption ᾱ = constant, (36) has a growing transient type solution of the form I<sub>c</sub> = exp pt, where p has the value (ᾱ - 1)ω<sub>0</sub>. Obviously the time τ required for the transient to grow by a factor of 10 is

The larger of the two values for p has to be used to calculate τ. For the values of R<sub>B</sub> and C used, the correction to (37) is again negligible.

ACKNOWLEDGMENT

The authors thank Prof. J. G. Linvill, Stanford University, Calif., for his helpful discussions, especially on transient response. Also Miss A. R. Miller for help with measurements, Miss J. Sullivan, and Mrs. M. Sturm, for assistance in preparing manuscript.

# Frequency Modulation Noise in Oscillators\*

J. L. STEWART†, MEMBER, IRE

**Summary**—Noise in oscillator tubes due to the discrete nature of the electron can result in frequency fluctuations equivalent to frequency modulation by a wide band of Gaussian noise at small mean-square frequency deviations. Amplitude fluctuations are ignored. Also, low-frequency noise due to flicker and similar phenomena is ignored. The effect of the band-pass filter normally present in an oscillator on the parameters of the noise modulation is determined. Also, the power spectrum of the oscillator output is evaluated which, as a practical measure, implies little more than the phase correlation time of the carrier. Finally, the theory is applied to reactance-modulated oscillators, some fixed-tuned conventional oscillators, and magnetrons. Noise equations which evaluate the mean-square frequency deviation and the spectral width at the output of oscillators are given.

## INTRODUCTION

THE OUTPUT signal from an oscillator is never a perfect periodic wave. Rather, it is always slightly corrupted with amplitude and frequency fluctuations. Amplitude fluctuations consist in general of background noise plus an equivalent noise modulation, which is generated by electronic processes inside the vacuum tube. The amplitude noise output may be greatly affected by whatever nonlinear characteristics prevail, as well as by the filter structure associated with the oscillator circuit. In principle, it is possible to reduce amplitude fluctuations arbitrarily by means of limiting and filtering.

The second component of noise is a frequency fluctuating component which, to a reasonable approximation, is equivalent to a perfect oscillator modulated in frequency with a low-pass band of Gaussian noise. As contrasted to amplitude fluctuations, frequency fluctuations cannot be reduced arbitrarily, but can be minimized only to the extent that the oscillator output can be passed through a narrow-band filter. Nonlinearities in the oscillator appear to have a relatively small effect.

A knowledge of fm noise is important in establishing the local oscillator noise in many types of cw and fm systems, most obvious of which is Doppler radar. The least amount of discriminator action, whether it be due to filter structures or radar echos, will convert frequency fluctuations into amplitude fluctuations and hence add to the noise in any system. Very little appears to have been written on the theory associated with fm noise in oscillators, probably because only recently have statistical analyses of frequency modulation by Gaussian

noise been available.<sup>1-3</sup> In some respects, the theory of fm oscillator noise is simpler than that for AM noise because nonlinearities do not appear to play a primary role. However, the theory can be quite involved because of the extremely complicated nature of network response to a frequency-varying signal. These difficulties will be avoided here by means of careful restrictions and assumptions (which nevertheless are reasonable).

Amplitude fluctuations are of no concern here and consequently will be ignored.

The AM and FM noise in the output of an oscillator can further be broken into two components, that due to low-frequency noise, and that due to high-frequency noise. Low-frequency noise due to such things as flicker, drift, microphonics, and so forth, is usually by far the largest in amplitude; however, it can often be made unimportant through careful construction and by avoiding systems which require the detection of low audio-frequency signals. High-frequency noise, with which this study is concerned, is due to the discrete nature of the electron and contains components extending from zero frequency to hundreds of megacycles. High-frequency noise phenomena can rarely be circumvented.

The random nature of electron motion in the vacuum tube associated with an oscillator gives rise to a random frequency modulation of the current fundamental sine-wave component in the tube. The tube current waveform can be considered to be a sine wave modulated in frequency with a low-pass band of noise having a power spectrum  $W(\omega)$ , as in Fig. 1. A mean-square radian frequency deviation of the modulated carrier can be defined as the area under the power spectrum  $W(\omega)$ .

The equivalent modulating signal may or may not be Gaussian. It would appear that it is nearly Gaussian in most oscillators, although it may not be Gaussian in certain low-frequency oscillators designed for the utmost in frequency stability. In order that available mathematics be applicable, the development here described will be restricted to those cases where Gaussian statistics are valid.

The power spectrum  $W(\omega)$  is normally relatively flat and wide; it reflects the presence of components at all

<sup>1</sup> D. Middleton, "On the Distribution of Energy in Noise- and Signal-Modulated Waves," Tech. Rept. No. 99, Cruft Laboratory, Harvard University, Cambridge, Mass.; March, 1950.

<sup>2</sup> D. Middleton, "On the distribution of energy in randomly modulated waves," *Quart. Appl. Math.*, Part I, vol. 9; January, 1952, and Part II, vol. 10; April, 1952.

<sup>3</sup> J. L. Stewart, "The power spectrum of a carrier frequency modulated by gaussian noise," *Proc. IRE*, vol. 42, pp. 1539-1542; October 1954.

\* Original manuscript received by the IRE, July 1, 1955; revised manuscript received, October 7, 1955. This work was sponsored by the Signal Corps, Department of the Army.

† University of Michigan, Ann Arbor, Michigan.



significant frequencies contained in a current composed of discrete particles. However, the ultimate output of an oscillator is almost always passed through some filter structure before appearing across a pair of terminals. The effect of the filter is to convert the equivalent modulating power spectrum  $W(\omega)$  to a new power spectrum  $W'(\omega)$ . The mean-square deviation of the modulated carrier and bandwidth of the equivalent modulating noise will be reduced appreciably through filtering, which implies that oscillators containing narrow-band filters have considerably less fm noise than those with essentially untuned structures.

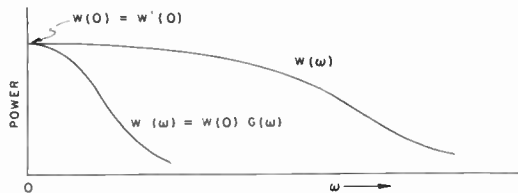

Fig. 1—Power spectra of the modulation signal.

The first derivation presented here determines the relationship between  $W'(\omega)$  and  $W(\omega)$ . Some care must be exercised in obtaining the results shown in Fig. 1. The effect of a filter on a carrier that is frequency modulated by noise is to introduce some amplitude fluctuations by virtue of nonconstant amplitude and nonlinear phase characteristics. This effect will be ignored here. More important, the equivalent frequency-modulating signal subsequent to the filter will not, in general, be Gaussian, even though the equivalent modulating signal prior to the filter is Gaussian. If Gaussian statistics are to be usable, certain assumptions are therefore required. First, the filter structure through which the oscillator output passes will be restricted to a band-pass filter having a bandwidth much larger than the frequency deviation prior to filtering. Further, the center frequency of the filter will be assumed to be close to the oscillator carrier frequency compared to the filter bandwidth. These assumptions insure that the side bands of the noise-modulated carrier will be symmetric and that the equivalent modulating signal will remain Gaussian. The narrow-band approximation will also be employed. All of these assumptions appear to be compatible with typical oscillator structures.

The effect of the filter is to cause the original modulating power spectrum  $W(\omega)$  to be multiplied by the low-pass equivalent of the filter power-gain function such that  $W(0)$  and  $W'(0)$  are equal. The mean-square deviation of the modulated carrier and the equivalent modulator noise bandwidth are thus reduced in direct proportion to the ratio of the spectral widths of  $W(\omega)$  and  $W'(\omega)$ .

The second topic to be considered is the shape of the power spectrum of the frequency-modulated carrier. It

is shown that the power spectrum is narrow and continuous with a bandwidth between half-power points of  $\pi W(0)$ , as in Fig. 2. The derivation assumes that the mean-square deviation (after filtering) is small compared to the bandwidth of the equivalent modulating source, which appears to be a realistic assumption. It is important to note that the width of the power spectrum of the modulated carrier is independent of filtering (typically it is much narrower than any passive filter that might conceivably be employed); it is dependent only on the intensity of the equivalent modulating noise power spectrum at and near zero frequency.<sup>3,4</sup> As contrasted to the power spectrum related to amplitude fluctuations, the power spectrum of a noise-frequency-modulated carrier implies almost nothing in so far as noise capture by external circuitry is concerned; additional knowledge of discriminator action is required.

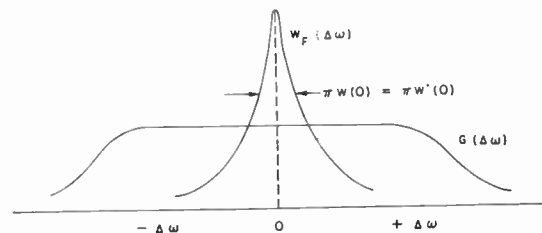

Fig. 2—Power spectrum of the modulated carrier and power gain of the filter.

Because the width of the power spectrum is dependent only on the modulating noise at zero frequency, the width implies little more than the phase correlation time of the carrier. For example, if the width is  $10^{-4}$  cycle, a period of roughly  $2 \times 10^4$  seconds is required for the phase angle of the oscillator output to become essentially uncorrelated.

Unfortunately, it appears extremely difficult to make a direct measurement of the width of the power spectrum resulting from frequency modulation by shot noise. This is partly due to the typically small width of the spectrum. More important, low-frequency noise will result in a much wider power spectrum (and often a much shorter phase correlation time) than that calculated here, although the skirts of the power spectrum will be little affected.

The theory is finally applied to two examples. The first is a reactance-modulated oscillator for which a basic noise law is developed showing that fm noise is dependent on the ease of tuning, becoming more severe as the oscillator is made to cover a larger tuning range. Then, the theory is applied to conventional magnetrons, starting from a previous analysis of a tunable magnetron operating into a broad-band (untuned) filter structure.<sup>5</sup>

<sup>4</sup> N. D. Blachman, in a private communication, pointed out the rather general dependence of the spectral width on  $W(0)$ .

<sup>5</sup> J. L. Stewart, "Theory of frequency modulation noise in tubes employing phase focusing," *Jour. Appl. Phys.*, vol. 26, pp. 409-413; April, 1955.

## EFFECT OF A BAND-PASS FILTER

Assume that a carrier is modulated in frequency with Gaussian noise having a power spectrum  $W(\omega)$ . This modulated wave is passed through a band-pass filter having a power gain  $G(\Delta\omega)$ , where  $\Delta\omega$  is the radian difference frequency from the carrier (thus  $G(\omega)$  is the low-pass equivalent power gain function). The bandwidth of the filter is assumed large compared to the deviation of the fm, the filter is assumed to be tuned to the carrier, the narrow-band approximation is made, and  $G(\Delta\omega)$  is normalized to  $G(0)=1$ . At the output of the filter, there will exist a carrier modulated in frequency with a band of noise having the power spectrum  $W'(\omega)$ . The equivalent modulating noise is assumed Gaussian. The problem is to determine  $W'(\omega)$  in terms of  $W(\omega)$  and  $G(\Delta\omega)$ .

The starting point of this analysis is the equation<sup>1-3</sup>

$$W_F(\Delta\omega) = \frac{A_0^2}{2\pi} \int_0^\infty \cos \Delta\omega\tau \cdot \exp \left[ - \int_0^\infty \frac{W(\omega)(1 - \cos \omega\tau)}{\omega^2} d\omega \right] d\tau, \quad (1)$$

where  $W_F(\Delta\omega)$  is the power spectrum of the modulated carrier as a function of the frequency difference from the carrier,  $W(\omega)$  is the power spectrum of the modulating noise, and  $A_0$  is the peak magnitude of the sine-wave carrier. The derivation of (1) assumes that the modulating noise is Gaussian and that the narrow-band approximation applies. Otherwise,  $W(\omega)$  is quite arbitrary.

Let the power spectrum defined by (1) be passed through the filter function  $G(\Delta\omega)$ . Then,  $W_F(\Delta\omega)G(\Delta\omega)$  is the modified power spectrum of the modulated carrier  $W_F'(\Delta\omega)$ . Therefore, the formal solution can be written in terms of an integral equation as

$$G(\Delta\omega) \int_0^\infty \cos \Delta\omega\tau \exp \left[ - \int_0^\infty \frac{W(\omega)(1 - \cos \omega\tau)}{\omega^2} d\omega \right] d\tau = \int_0^\infty \cos \Delta\omega\tau \exp \left[ - \int_0^\infty \frac{W'(\omega)(1 - \cos \omega\tau)}{\omega^2} d\omega \right] d\tau. \quad (2)$$

The general solution of this integral equation appears most formidable. However, by studying but a single component of noise and not worrying too much about convergence (which is evidently no great problem), the solution becomes relatively simple.<sup>6</sup>

Let  $W(\omega)$  be a delta function at  $\omega=\omega_a$  with an area  $\epsilon$  as

$$W(\omega) = \epsilon\delta(\omega - \omega_a). \quad (3)$$

The complete power spectrum can always be obtained as the linear superposition of many such components.

If it is assumed that this one component of the modulating signal is related to a single component in  $W'(\omega)$  in a one-to-one fashion (which is a valid assumption in view of stated approximations), then

$$W'(\omega) = \epsilon'\delta(\omega - \omega_a). \quad (4)$$

Substituting (3) and (4) in (2), the integral in the exponent disappears and there results

$$G(\Delta\omega) \int_0^\infty \cos \Delta\omega\tau \exp \left[ - \frac{\epsilon(1 - \cos \omega_a\tau)}{\omega_a^2} \right] d\tau = \int_0^\infty \cos \Delta\omega\tau \exp \left[ - \frac{\epsilon'(1 - \cos \omega_a\tau)}{\omega_a^2} \right] d\tau. \quad (5)$$

Within the relatively flat pass band of  $G(\Delta\omega)$  (that is, near the carrier),  $G(\Delta\omega)$  remains essentially constant at unity. Therefore, for small  $\Delta\omega$ ,  $\epsilon=\epsilon'$  and the power spectra  $W(\omega)$  and  $W'(\omega)$  are the same. For larger  $\Delta\omega$ ,  $G(\Delta\omega)$  decreases, which requires  $\epsilon'<\epsilon$ . Larger values of  $\Delta\omega$  are associated with larger values of  $\omega_a$ . Because the total noise frequency deviation has been assumed small, the modulating index associated with a component having a large  $\omega_a$  is very small; hence, the only significant sideband component in the modulated carrier will occur at  $\Delta\omega=\omega_a$ . Therefore, an approximation to (5) for  $\omega_a$  not small is obtained by setting  $\Delta\omega=\omega_a$ . Also approximating the exponentials in (5) with the first two terms of their power series, there is obtained

$$G(\omega_a) \int_0^\infty \cos \omega_a\tau \left[ 1 - \frac{\epsilon(1 - \cos \omega_a\tau)}{\omega_a^2} \right] d\tau = \int_0^\infty \cos \omega_a\tau \left[ 1 - \frac{\epsilon'(1 - \cos \omega_a\tau)}{\omega_a^2} \right] d\tau. \quad (6)$$

The first integral on either side of (6) is zero. Equating the second two integrals allows the equation to be differentiated. This gives

$$\epsilon' = G(\omega_a)\epsilon, \quad (7)$$

from which it is apparent that

$$W'(\omega) = G(\omega)W(\omega). \quad (8)$$

Thus, the bandwidth of  $W'(\omega)$  will not be larger than the semibandwidth of the band-pass filter, and the power spectra  $W(\omega)$  and  $W'(\omega)$  will be the same at  $\omega=0$ . The mean-square deviation prior to filtering is

$$D^2 = \int_0^\infty W(\omega)d\omega, \quad (9)$$

and that subsequent to the filter is

$$D'^2 = \int_0^\infty W'(\omega)d\omega = \int_0^\infty G(\omega)W(\omega)d\omega. \quad (10)$$

If the power spectrum  $W(\omega)$  is relatively white out to high frequencies, then the power spectrum  $W'(\omega)$  will have a shape essentially the same as  $G(\omega)$  with a value  $W(0)$  at  $\omega=0$  and with a mean-square deviation given by  $W(0)$  times the noise bandwidth of  $G(\omega)$ .

The derivation of (8) from (2) can be done in a slightly different manner, which is perhaps more attractive mathematically because it avoids the introduction of delta functions (although it is perhaps not so satisfying physically). The development is started as before; it is noted that  $W(\omega)$  and  $W'(\omega)$  are the same for

<sup>6</sup> S. O. Rice, "Mathematical analysis of random noise," *Bell Sys. Tech. Jour.*, vol. 23, pp. 282-333; July, 1944; vol. 24, pp. 146-157; January, 1945.

small  $\omega$  because  $G(\Delta\omega)$  is constant at unity. For  $\omega = \omega_x$  larger than the deviation, the arguments of the exponentials in (2) are small (because of the factor  $1/\omega^2$ ), which permits the exponentials to be approximated by the first two terms of their power series. This gives the equation

$$G(\Delta\omega) \int_0^\infty \int_{\omega_x}^\infty \frac{W(\omega)(1 - \cos \omega\tau) \cos \Delta\omega\tau}{\omega^2} d\omega d\tau \\ = \int_0^\infty \int_{\omega_x}^\infty \frac{W'(\omega)(1 - \cos \omega\tau) \cos \Delta\omega\tau}{\omega^2} d\omega d\tau, \quad (11)$$

which ignores the one integral on either side that is zero, as before.

If the order of integration in (11) is changed and integration performed first on  $\tau$ , it is seen that the integrals are zero unless  $\Delta\omega = \omega$ . The result of (8) follows immediately.

#### POWER SPECTRUM OF THE MODULATED CARRIER

Consider the exponential function under the integral of (1), which may be written in the form

$$E = \exp \left[ -\frac{\tau^2}{2} \int_0^\infty W(\omega) \left( \frac{\sin \frac{\omega\tau}{2}}{\frac{\omega\tau}{2}} \right)^2 d\omega \right]. \quad (12)$$

When  $\tau$  is very small, the  $(\sin x)/x$  variation is essentially constant at unity at all frequencies where  $W(\omega)$  is appreciable. Then

$$E \cong \exp \left[ -\frac{\tau^2}{2} \int_0^\infty W(\omega) d\omega \right] \\ = \exp \left[ -\frac{\tau^2 D^2}{2} \right], \quad \tau \text{ small.} \quad (13)$$

When  $\tau$  is large, the  $(\sin x)/x$  variation is virtually completed in the frequency range where  $W(\omega)$  is essentially constant at  $W(0)$ . Then,  $W(\omega) = W(0)$  can be moved outside the integral of (12) and the remaining term integrated to give

$$E \cong \exp \left[ -\frac{\tau\pi W(0)}{2} \right], \quad \tau \text{ large.} \quad (14)$$

The exponential in (1) is therefore a function of  $\tau$  that decreases as a Gaussian function for small  $\tau$  and as a simple negative exponential for large  $\tau$ .

The power spectrum near the carrier is of greatest interest. This corresponds to  $\Delta\omega$  small in (1). The angle  $\Delta\omega\tau$  must be appreciable if the power spectrum  $W_F(\Delta\omega)$  is to be significantly different from that at  $\Delta\omega = 0$ , which implies that  $\tau$  must be large. Thus, the asymptotic expression of (14) is of most concern. In the limit when  $W(\omega)$  is very broad and  $D$  very small, (14) is an acceptable approximation to the exponential for all  $\tau$ .

Substituting (14) in (1) and integrating

$$W_F(\Delta\omega) = (A_0^2/2) \frac{W(0)/2}{[\pi W(0)/2]^2 + [\Delta\omega]^2}, \quad (15)$$

which is the same as the square of the magnitude of the impedance of a parallel-resonant circuit (with the narrow-band approximation) and which is dependent only on the spectral intensity of the modulating signal at  $\omega = 0$ . The bandwidth between half-power points is

$$B_F = \pi W(0). \quad (16)$$

It should be noted that if the approximation of (13) is used in (1), the asymptotic solution for large  $D$  is obtained.<sup>3</sup>

The approximation of (14) is not valid if the power spectrum  $W(\omega)$  is not relatively flat at small frequencies, including zero. Vacuum-tube shot noise evidently always leads to a relatively flat  $W(\omega)$  in this region (neglecting low-frequency noise phenomena).

When the limiting situation for small  $D$  does not occur, the error that is introduced is dependent upon how much the approximation of (14) differs from (12). The error is primarily at medium values of  $\tau$ . If  $D$  is small but not vanishing, the bandwidth  $B_F$  will be slightly larger than that given by (16), and the skirts of the power spectrum somewhat steeper than that implied by (15). General tendencies can be deduced from a comparison of the asymptotic solutions for large and small  $D$ .<sup>3</sup>

#### APPLICATION TO REACTANCE-MODULATED OSCILLATORS

Let a reactance-modulated oscillator have a tank circuit with a total noise bandwidth  $b$  cycles per second. It will be assumed that when the grid voltage of the reactance tube is changed by 1 volt, the oscillation frequency is changed by  $g$  cps. The relation between the grid voltage and the frequency will be assumed linear and the change in frequency due to noise in the oscillator tube is assumed small by comparison with that due to noise in the reactance tube. The noise attributable to the electrons in the reactance tube is considered white with a bandwidth greater than  $b/2$ .

The reactance-tube noise can be assumed to occur as thermal noise in an equivalent resistor  $R_{eq}$  placed in series with the grid. This resistor can be adjusted to account for shot, partition, and induced grid noise, as well as thermal noise introduced at the grid from other sources such as resistors.

The mean-square frequency deviation (in cps) due to noise in a band  $\Delta f$  is

$$d^2 = 4kTR_{eq}\Delta fg^2, \quad (17)$$

where  $k$  is Boltzmann's constant and  $T$  is the absolute temperature. The total deviation is determined by the noise semi-bandwidth of the oscillator tuned circuit,  $b/2$ . Thus, at the oscillator output

$$d^2 = 2kTR_{eq}bg^2 = 7.95 \times 10^{-21} R_{eq}bg^2, \quad (18)$$

where the numerical evaluation is for  $T = 290^\circ\text{K}$ .

The intensity of the modulating noise per cycle at  $f = 0$  is  $4kTR_{eq}g^2$ . Thus, the bandwidth of the fm power spectrum between half-power points is

$$B_F = 4\pi kTR_{eq}g^2 = 5 \times 10^{-20} R_{eq}g^2. \quad (19)$$

As an example, assume  $R_{e,q} = 1,000$  ohms,  $b = 2 \times 10^6$  cps, and  $g = 2 \times 10^6$  cps. Then  $d = 8$  cps and  $b_F = 0.002$  cycle.

Eqs. (18) and (19) appear to represent a basic law of fm noise generation, which can be extended to voltage-tunable devices independently of the particular mechanism utilized for achieving voltage tuning. In particular, the amount of noise in easily tunable oscillators is worse than in oscillators not so readily voltage tuned. In addition, the noise is minimized when the circuitry has a very narrow bandwidth.

With some restrictions, (18) and (19) can be applied to fixed-tuned oscillators as well. All oscillators change frequency slightly as the grid voltage is changed. If the frequency is linearly dependent upon the grid voltage, (18) and (19) are applicable.

Some high-stability oscillators are adjusted so that the slope of the grid-voltage-versus-frequency curve is zero. It would then appear that no fm noise results. However, because all the derivatives of the grid-voltage-frequency curve cannot also be made zero at the operating point, there will always occur some fm noise, although the equivalent modulating signal may become distinctly non-Gaussian.

It would appear possible to use the data of this section for instrumentation purposes. A wide-band discriminator acting as a detector of an oscillator output will have amplitude fluctuations at its output, part of

which are due to detected frequency fluctuations. The amount of detected fm noise can conceivably be used to infer the value of  $R_{e,q}$  or to aid in the adjustment of the circuitry of stable oscillators to minimize  $g$ .

APPLICATION TO MAGNETRONS

A previous paper considered the fm noise in a voltage-tunable magnetron with an essentially untuned (wide-band) circuit.<sup>5</sup> The amount of fm noise calculated there is that attributable to the electrons themselves. A conventional magnetron operates in much the same manner as the voltage-tunable magnetron except that it employs a relatively narrow output cavity. Thus, the frequency deviation of the fm noise at the output of a conventional magnetron will be considerably less than that implied by previous equations.

A typical calculation from previous data might give a deviation of 50,000 cps and a bandwidth of  $500 \times 10^6$  cps. If a cavity with a noise semi-bandwidth of  $2 \times 10^6$  cps is employed as the circuit, then the deviation becomes

$$5 \times 10^4 \left[ \frac{2 \times 10^6}{500 \times 10^6} \right]^{1/2} = 3,160 \text{ cps}, \quad (20)$$

which is typical of values found experimentally.<sup>7</sup>

<sup>7</sup> W. M. Gottschalk, "Direct detection studies of noise in cw magnetrons," TRANS. IRE, vol. ED-1, pp. 91-98; December, 1954.

# Correspondence

## Russian Ionosphere Terminology\*

A fair portion of Russian scientific investigation is presently devoted to the ionosphere, especially at high latitudes. The vocabulary given below should be of assist-

ance to engineers who wish to peruse recent Russian literature treating wave propagation in this region.

Several of the terms given deserve comment: "incident wave" is literally the "falling-on-the-layer wave"; "interaction" is literally "mutual action." For some words Latin cognates are used equally with those

of Slavic origin (*i.e.*, *refraktsiya—prelomleniye*). Note also that in designating the layers of the ionosphere, Latin capitals are used.

G. F. SCHULTZ  
Indiana University,  
Bloomington, Ind.

\* Received by the IRE, December 29, 1955.

absorption	абсорбция; поглощение	passage	прохождение
diffraction	дифракция; отклонение	penetration	просачивание
incidence	падение	propagation	распространение
interaction	взаимодействие	direction of propagation	направление распространения
ionization	ионизация	longitudinal propagation	продольное распространение
ionization density	плотность ионизации	transverse propagation	поперечное распространение
abnormal ionization	ненормальная ионизация	reflection	отражение
ionosphere	ионосфера	refraction	рефракция; преломление
layer	слой	refractive index	показатель преломления
Appleton layer	слой Appletona	region	область
E layer	слой E	superposition	наложение
F layer	слой F	wave	волна
Heaviside layer	слой Хевисайда	electromagnetic wave	электромагнитная волна
ionized layer	ионизированный слой	extraordinary wave	необыкновенная волна
Kennelly-Heaviside layer	слой Кеннелли-Хевисайда	incident wave	падающая на слой волна
in layers	слоями	ordinary wave	обыкновенная волна
medium	среда	radio wave	радиоволна
absorbing medium	поглощающая среда	reflected wave	отраженная волна
homogeneous medium	однородная среда	sky wave	небесная волна
inhomogeneous medium	неоднородная среда	wavelength	длина волны
multiplication of signals	умножение сигналов		

### Variation with Temperature of Quartz Resonator Characteristics\*

Some special applications of quartz resonators require operating temperatures up to 250°C and higher. The suitability of AT-, BT-, CT-, DT- and X-type quartz resonators for these elevated temperatures is considered. The variation with temperature of the effective elastic and piezoelectric constants is shown. In addition, the effect of the temperature on the capacitance ratio of the resonator types is given.

W. P. Mason<sup>1</sup> has investigated the shear-mode resonators in the temperature range -100°C to +200°C and has determined the optimum angles of orientation for these resonator types in order to obtain minimum frequency excursion.

Atanasoff and Hart<sup>2</sup> have determined the effect of temperature on the elastic stiffnesses  $c_{44}$ ,  $c_{14}$  in the temperature range 0°C to 550°C and  $c_{11}$ ,  $c_{66}$  from 0°C to the inversion temperature of 573°C. Their results are shown in Fig. 1, together with the stiffnesses for AT- and BT-type resonators, calculated according to the equation

$$c_{\theta} = c_{44} \sin^2 \theta + c_{66} \cos^2 \theta - 2c_{14} \sin \theta \cos \theta; \quad (1)$$

where for the AT-cut  $\theta = 35^\circ$  and for the BT-cut  $\theta = -49^\circ$ . For elevated temperatures slightly different angles of orientation have to be used.

The elastic compliances  $s_{44}$ ,  $s_{66}$  and  $s_{14}$  calculated from the stiffnesses  $c_{44}$ ,  $c_{66}$ ,  $c_{14}$  are plotted as function of the temperature in Fig. 2. The variation with the temperature of  $s_{11}$  was measured by Perrier and Mandrot.<sup>3</sup> The resulting compliances for the CT- and DT-type resonator calculated according to the equation

$$s_{\theta} = s_{44} \cos^2 \theta + s_{66} \sin^2 \theta + 4s_{14} \sin \theta \cos \theta, \quad (2)$$

where  $\theta = 38^\circ$  for the CT-cut and  $\theta = -52^\circ 30'$  for the DT-cut, are also plotted in Fig. 2.

The piezoelectric strain constants  $d_{11}$  and  $d_{14}$  measured by Cook and Weisser<sup>4</sup> up to the inversion temperature are shown in Fig. 3, which also gives the resulting piezoelectric strain constants  $d_{\theta}$  for the CT- and DT-cut, calculated from equation

$$d_{\theta} = 2d_{11} \sin \theta \cos \theta + d_{14} \cos^2 \theta. \quad (3)$$

From the variation with temperature of  $d_{11}$  and  $d_{14}$  the piezoelectric stress constants  $e_{11}$  and  $e_{14}$ , using the elastic compliances as shown in Fig. 1, have been calculated and are plotted in Fig. 4, together with the resulting piezoelectric stress constants  $e_{\theta}$  for the AT- and BT-type resonators obtained from equation

$$e_{\theta} = e_{11} \cos^2 \theta - e_{14} \sin \theta \cos \theta. \quad (4)$$

The resulting piezoelectric stress constants for the AT-type and DT-type resonators show remarkably small change with temperature (see Figs. 4 and 3).

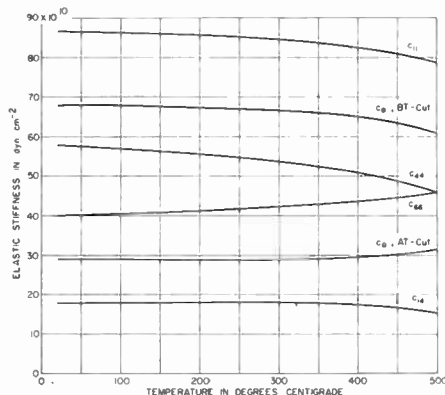

Fig. 1

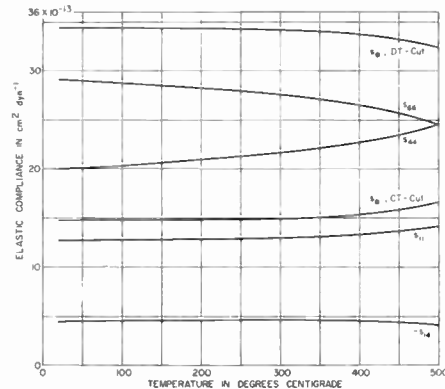

Fig. 2

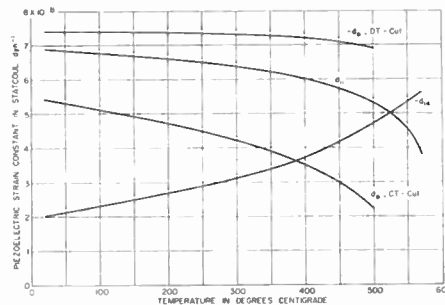

Fig. 3

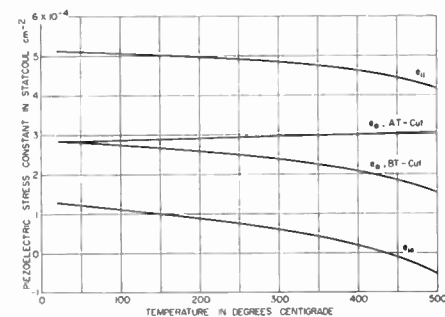

Fig. 4

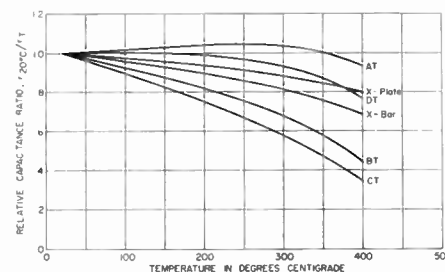

Fig. 5

The variation with temperature of the dielectric constants  $\epsilon_{11}$  and  $\epsilon_{33}$  was determined for elevated temperature. The resulting dielectric constants  $\epsilon_{\theta}$  for the AT-, BT-, CT- and DT-type resonators are then computed from the following equation:

$$\epsilon_{\theta} = \epsilon_{11} \cos^2 \theta + \epsilon_{33} \sin^2 \theta. \quad (5)$$

For the resonator types mentioned the capacitance ratio,  $r$ , is proportional as follows:

- AT-, BT-type to  $\epsilon_{\theta} c_{\theta} / \epsilon_{\theta}^2$
- CT-, DT-type to  $\epsilon_{\theta} s_{\theta} / d_{\theta}^2$
- thickness mode of X-plate to  $\epsilon_{11} c_{11} / \epsilon_{11}^2$
- length extensional mode of X-bar to  $\epsilon_{11} s_{11} / d_{11}^2$

The relative change with temperature of the capacitance ratio  $r_{200}/r_T$  of the AT-, BT-, CT- and DT-cuts, the thickness mode of the X plate, and the length extensional mode of the small X bar was calculated from the values given in graphs 1 to 4 and the dielectric constants. The results are plotted in Fig. 5.

Measurements of the capacitance ratio of AT- and BT-type resonators made up to 300°C are in good agreement with the curves of Fig. 5. The change with temperature of the capacitance ratio particularly for AT- and DT-type resonators is small and shows suitability for filter purposes in the elevated temperature range. Measurements for the other cuts should be made.

RUDOLF BECHMANN  
and VERA DURANA  
Clevite Res. Center  
Clevite Corp.  
Cleveland, Ohio

### Transfer Ratios of Resistance and RLC Networks\*

In his note<sup>1</sup> in your issue of November, 1955, Schwarz gives a simple proof that the voltage transfer ratio of a resistance network cannot exceed unity, this fact being relevant to the voltage transfer ratio of a passive RLC network without transformers, as discussed by Reza and Lewis.<sup>2</sup>

I write to point out that Schwarz's proof is almost identical with one that I have given in a recent paper<sup>3</sup> (written before the appearance of Reza and Lewis's note), in which, moreover, I prove a similar theorem for current transfer ratio, and use these results to deduce in an elementary way various algebraic properties of the transfer ratios of both resistance networks and RLC networks without mutual inductance.

A. TALBOT  
Imperial College  
of Science and Technology  
University of London  
London, Eng.

\* Received by the IRE, December 28, 1955.  
<sup>1</sup> R. J. Schwarz, "A note on the transfer voltage ratio of resistance networks with positive elements," Proc. IRE, vol. 43, p. 1670; November, 1955.  
<sup>2</sup> F. M. Reza and P. M. Lewis II, "A note on the transfer voltage ratio of passive RLC networks," Proc. IRE, vol. 42, p. 1452; September, 1954.  
<sup>3</sup> A. Talbot, "Some fundamental properties of networks without mutual inductance," IEE Monograph No. 118R; January, 1955.

\* Received by the IRE December 14, 1955.  
<sup>1</sup> W. P. Mason, "Zero temperature coefficient quartz crystals for very high temperatures," Bell Sys. Tech. Jour., vol. 30, pp. 366-380; April, 1951.  
<sup>2</sup> J. V. Atanasoff and P. J. Hart, "Dynamical determination of the elastic constants and their temperature coefficients for quartz," Phys. Rev., vol. 59, pp. 85-96; January, 1941.  
<sup>3</sup> A. Perrier and R. de Mandrot, "Elasticity and symmetry of quartz at high temperatures," Mem. Soc. Vaudoise Sci. Nat., vol. 1, pp. 333-364; 1923.  
<sup>4</sup> R. K. Cook and P. G. Weisser, "Piezoelectric constants of alpha- and beta-quartz at various temperatures," Phys. Rev., vol. 80, pp. 712-716; November, 1950.

Signal-Seeking Devices\*

With some nostalgia I read a recent excellent article<sup>1</sup> on one aspect of automatic signal seeking radios which use the "difference voltage" technique. This technique was also known 12 years ago under the name of a "Strandberg discriminator." At that time I either developed by myself or was shown by others in the groups working on these problems at TRE, Malvern, England, or at the Harvard RRL, similar design and recorded data curves. The technique was actually used in D-Day jamming apparatus, I have been told. I have been under secrecy restrictions on the subject of automatic seeking devices until a letter of October 20, 1954 specifically declassified my original patent disclosure. The patent was subsequently issued as #2,703,362 on March 1, 1955. This was a good deal after the publication and commercialization of identical work by others, which I was forced to watch without being able to offer assistance or advice.

This situation must have been duplicated thousands of times in other cases, but it does demonstrate in a picayune manner, the personal tragedy of security regulations in their denial to the creative man the personal satisfaction that arises from the professional recognition and use of his creations.

M. W. P. STRANDBERG  
77 Massachusetts Ave.  
Cambridge 38, Mass.

\* Received by the IRE, December 5, 1955.  
<sup>1</sup> C. C. Hsu, "On the principle and design of a trigger circuit of a signal-seeking radio using 'difference voltage'," PROC. IRE, vol. 43, pp. 1591-1607; November, 1955.

On Passive and Active Networks and Generalized Norton's and Thevenin's Theorems\*

The purpose of this communication is to suggest revised definitions for the terms "passive" and "active," and, incidentally, to describe an extension of Norton's and Thevenin's theorems to multipole networks.

According to current terminology, a network element,  $\alpha$ , is *passive* if the total power input into  $\alpha$  is non-negative for all real frequencies;  $\alpha$  is *active* if it is non-passive, i.e., if for some input voltages and/or currents the total power input is negative.

It may be more appropriate, however, to define "passive" and "active" not in terms of the sign of the total power input, but in terms of the form of the input-output relationship of the element. Then, an additional set of three disjoint categories of network elements, *dissipative*, *lossless*, and *amplificative*, may be introduced to classify network elements according to their ability or inability to deliver more power to external loads than is supplied to them via their inputs.

In what follows, the proposed classifications for linear time-invariant networks are

\* Received by the IRE December 1, 1955.

defined in terms of terminal currents and potentials—which are external observables—rather than in terms of the internal network structure and composition. As usual, voltages and currents are described by their complex amplitudes and it is assumed that  $s = j\omega$ .

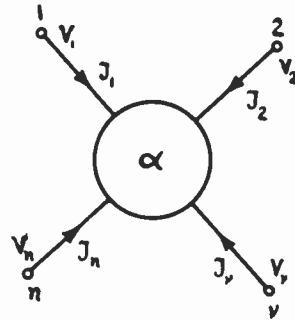

Fig. 1—N-pole notation.

Consider an  $n$ -pole,  $\alpha$  (Fig. 1), in which the  $J_\nu$  and  $V_\nu$  denote the terminal currents and potentials respectively.  $\alpha$  will be said to be *passive* if its current-potential relations admit a representation of the form<sup>1</sup>

$$J_\mu = \sum_{\nu=1}^n Y_{\mu\nu} V_\nu, \quad \mu = 1, 2, \dots, n, \quad (1)$$

where the  $Y_{\mu\nu}$  are constants independent of the  $J_\mu$  and  $V_\nu$ . (The  $Y_{\mu\nu}$  are given by

$$Y_{\mu\nu} = J_\mu \text{ when}$$

$$V_\nu = 1 \text{ and all other potentials are zero, } (2)$$

and have the property  $\sum_\mu Y_{\mu\nu} = \sum_\nu Y_{\mu\nu} = 0$ .)

The essence of this definition is that a network element is passive if its outputs are completely dependent upon the inputs and are zero in the absence of inputs. Whether the power level of outputs exceeds, or is less than, that of inputs is immaterial.

A network element,  $\alpha$ , will be said to be *active* if its current-potential relations admit the representation

$$J_\mu = \sum_{\nu=1}^n Y_{\mu\nu} V_\nu - \tilde{J}_\mu, \quad \mu = 1, 2, \dots, n, \quad (3)$$

where the  $Y_{\mu\nu}$  have the same significance as in (1) and the  $\tilde{J}_\mu$  are constants independent of the  $J_\mu$  and  $V_\nu$ . Here the outputs  $J_\mu$  depend not only on the inputs  $V_\nu$  but also on the  $\tilde{J}_\nu$ , which account for the internal voltage and/or current sources in  $\alpha$ . This furnishes a justification for calling an  $\alpha$  characterized by (3) an *active n-pole*.

The above definition implies that any  $n$ -pole which is composed of passive multipoles (in the sense of (1)) and voltage and/or current sources can be represented in the form (3); i.e., as a parallel combination of an  $n$ -pole current source  $\{\tilde{J}_\mu\}$  and a passive  $n$ -pole  $\alpha_0$  characterized by the  $Y_{\mu\nu}$  (Fig. 2). In effect, this assertion constitutes an extension of Norton's theorem to  $n$ -poles,<sup>2</sup> in which the  $\tilde{J}_\mu$  are identified with the nega-

<sup>1</sup> If one or more of the  $Y_{\mu\nu}$  are infinite (e.g., the  $Y_{\mu\nu}$  of an ideal transformer), then  $\alpha$  is passive if it is a limit of a sequence of passive  $n$  poles in the sense of (1).

<sup>2</sup> More detailed statements and proofs of extended Norton's and Thevenin's theorems are given in a forthcoming paper.

tives of the currents flowing through the terminals of  $\alpha$  when all of them are short-circuited, while  $\alpha_0$  is the  $n$ -pole resulting from  $\alpha$  when all voltage sources in  $\alpha$  are short-circuited and all current sources are open-circuited.

By transforming the parallel combination of  $\alpha_0$  and  $\{\tilde{J}_\mu\}$  into a series combination of  $\alpha_0$  and a  $2n$ -pole voltage source  $\{V_\nu^0\}$  (Fig. 2) one gets an analog of Thevenin's theorem for  $n$ -poles. Its statement reads: Any  $n$ -pole composed of passive multipoles [in the sense of (1)] and voltage and/or current sources is equivalent to a passive  $n$ -pole  $\alpha_0$  in series with a  $2n$  pole voltage source  $\{V_\nu^0\}$ .  $\alpha_0$  is obtained from  $\alpha$  by short-circuiting all voltage sources in  $\alpha$  and open-circuiting all current sources.  $\{V_\nu^0\}$  is obtained by open-circuiting the terminals of  $\alpha$  and setting  $V_\nu^0$  equal to the open-circuit potential of  $\nu$ th terminal. (Note that the  $V_\nu^0$  are thus determined to within an arbitrary additive constant.)

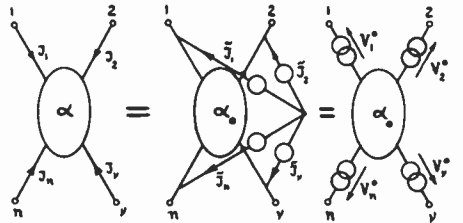

Fig. 2—Norton and Thevenin equivalents of an active  $n$  pole.  $\alpha_0 = n$  pole resulting from short-circuiting all voltage sources and open-circuiting all current sources in  $\alpha$ ;  $\tilde{J}_\mu = -$  (current flowing into  $\mu$ th terminal when all terminals are short-circuited);  $V_\nu^0 =$  open-circuit potential of  $\nu$ th terminal.

Now for purposes of classification with respect to the relative power levels of input and output, the following three categories are suggested.

1) *Dissipative n-poles*: An  $n$ -pole,  $\alpha$ , is *dissipative* (or *attenuative*) if the total power input,  $P$ ,  $P = Re \sum_\mu J_\mu V_\mu^*$ , is non-negative for all real frequencies and all  $V_\mu$ , and is positive for at least one real frequency and one set of values of  $V_\nu$ .

2) *Lossless n-poles*: An  $n$ -pole is *lossless* (or *loss-free*) if  $P$  is zero for all real frequencies and all  $V_\mu$ .

3) *Amplificative n-poles*: An  $n$ -pole is *amplificative* (this rhymes with dissipative) if  $P < 0$  for some frequencies and for some  $V_\mu$ .

A few examples will serve to illustrate the proposed classifications. (a) A positive resistor is passive and dissipative. (b) A negative resistor is passive and amplificative. (c) A vacuum-tube (small signal equivalent) is passive and amplificative. (d) Any passive  $n$ -pole with a real skew-symmetric  $Y$  matrix is lossless (the 4-pole gyration being a special case of such an  $n$ -pole). (e) The series combination of a positive resistor and a voltage source is active and amplificative. (f) An ideal transformer is passive and lossless.

L. A. ZADEH  
Dept. of Elect. Engrg.  
Columbia University  
New York 27, N. Y.

**A Note on Local Feedback\***

Local negative feedback in a degenerative loop is generally avoided. The reason is that over-all degeneration is by far more effective in stabilizing gain of a multistage amplifier than is negative feedback over the individual stages.<sup>1</sup>

The purpose of this note is to draw attention to an interesting property of local negative feedback in a degenerative loop which may be useful in practical cases because it makes it possible to reduce driving point impedances below the limit set for single loops.

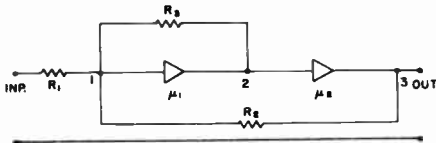

Fig. 1—Over-all and local negative feedback.

The circuit in Fig. 1 represents two dc amplifiers with the amplifications  $\mu_1$  and  $\mu_2$ . Over-all negative feedback is applied through  $R_2$  and local negative feedback through  $R_3$ . Two return differences are of interest here. One is measured for the first tube of  $\mu_1$  and is given by

$$F_1 = 1 + \mu_1 \mu_2 \beta, \quad (1)$$

$\beta$  denoting the feedback ratio. For frequencies much lower than the asymptotic frequency of  $\mu_2$ ,  $F_1$  is roughly equivalent to the return difference which would be obtained without the local loop.<sup>2</sup>

The other one is measured for the first tube of  $\mu_2$  and is given by

$$F_2 = 1 + \mu_2 \frac{R_3}{R_2}, \quad (2)$$

provided  $\mu_1$  is high and independent of frequency.

If the local loop is in itself stable the circuit may be considered as a single loop comprising  $\mu_2$  and the transfer function from the point 3 to point 2 (denoted by  $T_{32}$ ). The stability of the loop is determined by  $F_2$ . The maximum permissible value of  $F_2$  (in db) for a given frequency band when a phase margin  $x_2$  and an amplitude margin  $y_2$  are required is given by<sup>2</sup>

$$F_{2max} = 40 \log \frac{4f_{a2}}{n_2 f_0} - \left( 40 \log \frac{4f_{a2}}{n_2 f_0} + 17.4 \right) y_2 - \frac{n_2 - 2}{n_2} x_2 - \frac{2}{n_2} x_2 y_2, \quad (3)$$

where  $f_2$  is the asymptotic frequency of  $\mu_2$ ,  $f_0$  the useful frequency band, and  $n_2$  the asymptotic slope of  $\mu_2$ .

The driving point impedance at point 1 is given by<sup>3</sup>

$$Z_1 = Z_{10} \frac{F_1(0)}{F_1(\infty)}, \quad (4)$$

where  $Z_{10}$  is the passive impedance between 1 and ground,  $F_1(\infty)$  the return difference for the first tube of  $\mu_1$  and  $F_1(0)$  the return difference for the same element when 1 is shorted to ground.  $F_1(0)$  is obviously unity, and  $F_1(\infty) = F_1$  thus

$$Z_1 = Z_{10} / 1 + \mu_1 \mu_2 \beta. \quad (5)$$

Since  $F_1$  is not limited by stability considerations,  $Z_1$  may be made arbitrarily low. In practical cases, however, the assumption that  $\mu_1$  is independent of frequency will not hold. This sets a two-fold limit to the possible decrease of driving point impedances. In the first place,  $\mu_1$  will be limited by a formula similar to (3) in order to ensure stability of the local loop. In addition,  $F_2$  will have in general to be smaller than the value given by (3), as shown by the following considerations. Fig. 2 shows an idealized cutoff characteristic of  $\mu_2$  together with probable frequency characteristics of  $\mu_1$  and  $T_{32}$ .  $f_c$  denotes the frequency for which the phase shift of  $\mu_2$  reaches 180 degrees.

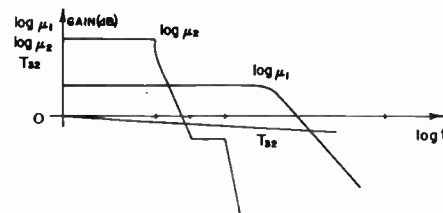

Fig. 2—Gain and phase shift of the amplifiers  $\mu_1$  and  $\mu_2$  and of the transfer function  $T_{32}$ .

The phase shift of  $\mu_1$  and  $T_{32}$  reach 180 degrees for the same frequency,  $f_c$ , although for lower frequencies the phase shift of  $T_{32}$  is appreciably lower than that of  $\mu_1$ , provided this latter is sufficiently high. We further assume that  $f_c > f_{a2}$ . This can always be arranged by reducing the bandwidth of  $\mu_2$ . Both the phase shift and attenuation of  $T_{32}$  for  $f_d$ , denoted by  $\phi_d$  and  $\xi_d$  respectively, will with the given assumptions be low. The presence of an additional phase shift in the loop makes it necessary to decrease  $F_2$ .  $\phi_d$  being small, the required decrease of  $F_2$  may be evaluated by looking upon it as a result of increasing the phase margin by  $\phi_d$ . The attenuation represents in itself an amplitude margin, so that the specified margin  $x_2$  may be reduced by  $\xi_d$ . The maximum value of  $F_1$  is thus

$$F_{1max} = [\log \mu_1]_{max} + 40 \log \frac{4f_{a2}}{n_2 f_0} - \left( 40 \log \frac{4f_{a2}}{n_2 f_0} + 17.4 \right) (y_2 - \phi_d) - \frac{n_2 - 2}{n_2} (x_2 - \xi_d) + \frac{n_2 - 2}{n_2} (x_2 - \xi_d) (y_d + \phi_d). \quad (6)$$

This value also gives the maximum possible decrease of driving point impedances for a specified frequency band. It represents the theoretical limit that can be attained when special filters are designed for the interstages in order to obtain ideal cutoff characteristics. Without them  $\mu_1$  and  $\mu_2$  will have to be much lower.

It can be seen that the improvement brought about by the addition of the local loop is due to the fact that the return difference which determines the extent of decrease in driving point impedances is no longer the same return difference which is limited by (3). This improvement is therefore obtainable irrespective of whether special interstage filters are used or not.

The extent of improvement obtained by the addition of local feedback depends in any case on the extent to which  $\mu_1$  depends on frequency. In cases in which the bandwidth of  $\mu_1$  is much larger than that of  $\mu_2$  the stability of the local loop is the only practical limit and great improvements may be achieved.

Thus, the method described may be used either to reduce driving point impedances below the limit set for a single loop, or else as an alternative to the design of complicated interstage filters which are required if the theoretical single loop limit is to be approached.

The following examples will serve as illustrations.

1. An operational amplifier having a virtual ground (e.g., for an adder) is to be designed for a moderate frequency range. The design is to be based on an output stage having for some reason a very low asymptotic frequency. A circuit such as that of Fig. 1 may be used to advantage if an amplifier with  $f_c > f_{a2}$  is available.

2. A closed negative loop is to be built around an amplifier containing electro-mechanical transducers (e.g., motors) and having in consequence a very low frequency band. To minimize the effect of external disturbances, the driving point impedances must be as low as possible. To achieve this, local feedback may be applied in two ways, as shown in Fig. 3. In Fig. 3(a) the feedback is a motion, and hence a second motor  $M_2$  is needed. In the case of Fig. 3(b) the frequency band of  $\mu_2$  has to be lower than that of the motor and the associated amplifier.

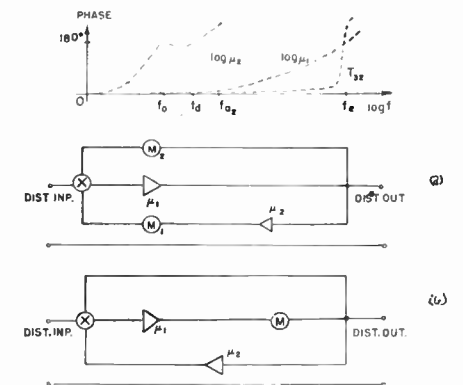

Fig. 3—Local and over-all negative feedback applied to minimize the effect of external disturbances.

A similar method was applied in an ac voltage stabilizer recently described by the author.<sup>4</sup>

A. FUCHS  
Scientific Department  
Ministry of Defense  
P.O. Box 7063,  
Hakiryra, Tel Aviv, Israel.

<sup>4</sup> A. Fuchs, "An ac voltage stabilizer." *Bull. Res. Council of Israel*, vol. 4, No. 4; March, 1955.

\* Received by the IRE, June 24, 1955.  
<sup>1</sup> G. E. Valley and H. Wallman, "Vacuum Tube Amplifiers," MIT Rad. Lab. Series, McGraw-Hill Book Co., Inc., New York, N. Y., vol. 18, p. 476; 1948.  
<sup>2</sup> H. W. Bode, "Network Analysis and Feedback Amplifier Design," D. Van Nostrand Co., Inc., New York, N. Y., pp. 466-468; 1945.  
<sup>3</sup> *Ibid.*, p. 67.

# Contributors

H. E. Beste was born in New York City, N. Y. on July 30, 1909. He was graduated from R.C.A. Institutes in 1932.



H. E. BESTE

A radio amateur since 1933, Mr. Beste engaged in radio service and designed public address equipment prior to employment by Allen B. Du Mont Laboratories, Inc.

In May, 1940, he began work at Du Mont as a television receiver field engineer and transferred to the Transmitter

Division in November, 1940, to do test and design work on studio equipment. In 1941, Mr. Beste joined the Research Division where he developed automatic scheduling equipment used in the manufacturing of cathode-ray tubes. He also developed equipment for checking persistence and decay time of cathode-ray tubes.

From 1942 to 1946, he was engaged in development and design of nondestructive electronic metallurgical instruments, radar precision position indicators, and high-stability television sync generators.

Mr. Beste was located in the Receiver Division of the Allen B. Du Mont Laboratories from 1946 to 1949 as project engineer on development and design of the first post-war television receivers and field sequential color receivers.

He was transferred to the Research Laboratories in 1951 to work exclusively on the development and design of color television equipment.

He is now in charge of color receiver development. He holds 9 patents and is co-inventor of 1 patent and has been active on subcommittees of the National Television Standards Committee.



R. G. Clapp (A'35-SM'44) was born on March 3, 1911, in Hanover, N. H. He graduated from the University of Pennsylvania in



R. G. CLAPP

1931. Since 1934 he has been in the engineering and research departments of Philco Corp., working on home radio, phonographs, radar, communications, fm, uhf, and black-and-white and color television.

At the present time he is section engineer in charge of color television research in the Philco Research Division. He was a member of panels of the Radio Technical Planning Board and the National Television System Committee, and several RETMA and JETC committees.



E. G. Clark (A'49) was born in Richmond, Va. on December 23, 1927. He received the B.S. degree in physics from the

College of William and Mary in 1948. The same year he was employed by the Research Division of Philco Corp. He subsequently joined the television advanced development laboratory and specialized in noise-immune synchronizing circuits.



E. G. CLARK

From 1953 to 1955, he was a project engineer working principally on color television. In October, 1955, Mr. Clark joined the special products division of the Burroughs Corp., Paoli, Pa.



P. P. Coppola was born in Buffalo, N. Y. in 1917. He received the B.S. degree in chemistry in 1941, and the M.S. degree in 1951, both from Canisius College. He attended N.Y.U. in 1949 and 1950.



P. P. COPPOLA

During 1941 and 1942, Mr. Coppola was associated with the Union Carbon and Carbide Corp. as an analytical chemist and group leader. From 1943 to 1946, under a Manhattan District contract with

the same corporation, he was concerned with trace methods and purification techniques for uranium materials. In 1946, he joined Philips Laboratories, Inc. as an assistant research chemist, and became associate research chemist in 1951 and research chemist in 1954. His research was in ultra pure materials, phosphors, semiconductors, and thermionic emission.

In August, 1955, he became associated with RCA in Lancaster, Pa., as a design and development engineer.



R. J. Farber (S'45-A'47-SM'53) was born in New York, N. Y. on May 28, 1924. He attended Columbia University, receiving the A.B. in 1943 and then entered the Signal Corps.



R. J. FARBER

In 1946, he joined the Hazeltine Electronics Corp. He has had experience with a wide variety of radar and radar test equipment projects, nuclear energy instrumentation, as well as broadcast and television receivers. He

was engaged in the National Television Standards Committee color television development, serving with Panel 16. He is currently engineer in charge of the Hazeltine Corp. licensee laboratory.

In 1950 Mr. Farber received the M.E.E. degree from New York University. He is a member of Phi Beta Kappa.

A. K. H. Goldberger was born in Philadelphia, Pa. on October 7, 1926. He received the B.S. degree from Pennsylvania State University in 1949. Until 1952, he was with the Research Division of Philco Corp. developing low noise receivers and crystal mixers.



A. K. GOLDBERGER

In 1952, Mr. Goldberger joined the staff of the Electronic Tube Research Division of the Compagnie Générale de Télégraphie Sans Fil,

Paris, France, where he was engaged in the study of traveling-wave tubes and carcinotrons. In 1953, he transferred to the United States subsidiary of Compagnie Générale de Télégraphie Sans Fil, American Radio Co.



G. Howitt (S'48-A'49-M'55) was born on November 19, 1926, in Brooklyn, N. Y. He attended the University of Cincinnati in



GEORGE HOWITT

1944-45 and received the B.E.E. degree from Cornell University in 1949. He did postgraduate work at Stevens Institute of Technology in 1950 and 1951.

Mr. Howitt joined the Television Receiver Engineering Department of the Allen B. Du Mont Laboratories in 1949.

From 1949 to 1953 he was engaged in the design and development of signal and deflection circuits and components for television receivers. In 1953 he assumed responsibility for the color TV receiver design section. He joined CBS Laboratories in 1954 where he engaged in advanced development of color receivers. He returned to the Research Division of the Allen B. Du Mont Laboratories in 1955, where he is now responsible for television and communication receivers.

Mr. Howitt is an associate member of the American Institute of Electrical Engineering.



R. C. Hughes was born in Ila, Ga., on December 23, 1910. He received the B.S. in 1933, and the M.S. in 1938 from the University of Florida.



R. C. HUGHES

From 1933 to 1937, he was a teacher of high school sciences. For one year he was an instructor in physical sciences at the University of Florida. He joined the Florida Agricultural Experiment Station in 1938 and was engaged in research in the preparation

and analysis of high-purity inorganic substances. From 1941 to 1946 he directed a



program of research and development on a variety of materials and equipment at the U.S. Naval Shipyard in Philadelphia.

In 1946 he became associated with Philips Laboratories as chief chemist. He has been studying the chemical aspects of research on solid-state and electronics problems. His present interests include the chemical technology of semiconductor materials, materials technology for electron tubes, and thermionic emitters.

He is a member of the American Chemical Society and the Electrochemical Society.



A. W. Lo (S'48-A'50) was born in Shanghai, China, on May 21, 1916. After receiving the B.S. degree in physics from Yenching University in 1938, he taught in West China Union University and Yenching University until he came to the United States in 1945. He received his M.S. degree in physics from Oberlin College in 1946, and his Ph.D. in electrical engineering from the University of Illinois



A. W. LO

in 1949, while serving as a research associate. He spent the following year as assistant professor in electrical engineering at Michigan College of Mining and Technology, and the next as lecturer in electrical engineering at the College of the City of New York.

Dr. Lo joined RCA in 1951 as a member of the staff of the Advanced Development Engineering Section of the Engineering Products Department working on transistor circuitry. In 1952 he was transferred to the RCA Laboratories in Princeton, N. J., and is currently working on the application of solid state switching devices.

Dr. Lo is a member of Sigma Xi, Phi Kappa Phi, Pi Mu Epsilon, Eta Kappa Nu, and the American Association of University Professors. He is a co-author of the book *Transistor Electronics*.



P. C. Palluel was born in London on November 25, 1913. He received the degree of Engineer from Ecole Supérieure de Physique et Chimie de Paris in 1935.



P. C. PALLUEL

Following his graduation he was engaged in research on photo-cells, secondary emission and electron-multipliers at the LMT Laboratories. In 1947, he joined the electronics department of the Compagnie Générale de Télégraphie Sans Fil. He has been in charge of research and development work on O Carcinotron tubes since 1951

M. O. Pyle (S'46-A'48-M'54) was born in Vacaville, Calif. on March 10, 1918. He received the A.B. degree in 1946 from San Jose State College in California.



M. O. PYLE

From 1948 until the present time, he has been with the RCA Service Co., Inc. in Camden, N. J. During this time, Mr. Pyle has served as a field engineer, quality control manager, and is training manager at the present time.



J. A. Rajchman (SM'46-F'53), was born in London, England, on August 10, 1911. He received his diploma in electrical engineering in 1934 and the degree of Doctor of Technical Sciences in 1938 from the Swiss Institute of Technology. In 1936 he joined the staff of the RCA Manufacturing Co. as a research engineer and in 1942 was transferred to the RCA Laboratories in Princeton where he is



J. A. RAJCHMAN

a member of the research staff, specializing in electron optics and computing devices. He is chiefly responsible for the development of the electron multiplier tube, and was co-recipient of the 1947 Levy Medal of the Franklin Institute for work on the betatron. He developed many computing circuits, the selective electrostatic storage tube, magnetic core memory, magnetic switches, and the transfluxor. He continues to be active in the field of magnetic storage and switching devices, and holds approximately 50 U. S. patents.

Dr. Rajchman is a member of the American Physical Society, the Council of the Association for Computing Machinery, and Sigma Xi.



Emil Sanford (A'54) was born on April 18, 1917, in Irvington, N. J. He attended the public schools of northern New Jersey and graduated from high school in 1935. Further than this, Mr. Sanford is self-trained.



EMIL SANFORD

During World War II he served as an instructor at the Eastern Signal Corps Schools in Fort Monmouth, N. J., and later his assignment was to the Pacific Theatre as a technical sergeant with a radio transmitter team.

In the post-war period, he worked in several companies in New Jersey, each time in an engineering capacity. In 1949, he joined the Allen B. Du Mont Laboratories where he holds the position of senior engineer.

H. Schenkel was born on February 18, 1929, in Winterthur, Switzerland. He received the M.S. degree in electrical engineering from the Swiss Federal Institute of Technology in Zurich, Switzerland in 1952. Since 1953, Mr. Schenkel has been employed as an engineer in the Semiconductor Laboratory of Raytheon Manufacturing Co., located in Newton, Mass. where he has been engaged in study of transistor applications and design.



H. SCHENKEL

❖

Hermann Statz was born in Germany on January 9, 1928. He received the Diploma in Physics in 1949, and the Doktor der Naturwissenschaften degree in 1951, from the Technische Hochschule, Stuttgart. During the years from 1949 to 1951 he was a research associate at the Max Planck Institut für Metallforschung, Stuttgart. From 1951 to 1952 he held a research stipend from Deutsche Forschungsgemeinschaft; his work was concerned with problems in theoretical solid state physics. In 1952 he joined the staff of the Solid State and Molecular Theory Group at the Massachusetts Institute of Technology, where he worked on the theory of ferromagnetism. Since 1953 he has been with the Research Division of Raytheon Manufacturing Co., Waltham, Mass., doing research in solid state physics and related fields.

Dr. Statz is a member of the American Physical Society.



J. L. Stewart (S'48-A'50-M'53) was born in Pasadena, Calif., on April 19, 1925. After serving as an aerial navigator during World War II, he returned to Stanford University where he received the B.S., M.S., and Ph.D. degrees in 1948, 1949, and 1952.



J. L. STEWART

From 1949 to 1951, Dr. Stewart was employed at the California Institute of Technology Jet Propulsion Laboratory and the Hughes Aircraft Co., Culver City, Calif. From 1952 to 1953, he was a research associate at the Stanford University Electronics Research Laboratory. Since 1953, he has been assistant professor of electrical engineering at the University of Michigan, and consultant to the Engineering Research Institute at the University.

Dr. Stewart is a member of Tau Beta Pi and Sigma Xi.

## 1956 IRE NATIONAL CONVENTION PROGRAM

Waldorf-Astoria Hotel, Kingsbridge Armory, March 19-22, New York, N.Y.

## GENERAL COMMITTEE

G. W. Bailey, *Chairman*  
S. L. Bailey, *Vice-Chairman*  
A. V. Loughren, *Ex-Officio*  
Emily Sirjane, *Secretary*

Horace Atwood      W. C. Copp  
W. M. Baston      L. G. Cumming  
J. F. Bisby      E. K. Gannett  
J. B. Buckley      R. R. Law  
R. P. Burr      J. S. Saby  
B. F. Tyson

## BANQUET COMMITTEE

R. P. Burr, *Chairman*

W. C. Espenlaub      P. M. Lally  
J. W. Kearney      E. U. Thomas  
R. J. Keogh      R. D. Wengenroth  
F. G. Willey

## COCKTAIL PARTY COMMITTEE

B. F. Tyson, *Chairman*

K. E. Farr      D. E. George

## EXHIBITS MANAGER

W. C. Copp

## FACILITIES COMMITTEE

W. M. Baston, *Chairman*  
R. E. Olson, *Vice-Chairman*

E. W. Borden      J. F. Eagan  
Oleg Boychenko      Samuel Grodzinsky  
S. D. Browning      T. M. Grybowski  
Christopher Buff      R. M. Hammer  
H. L. Busching      Zoltan Hartmann  
J. W. Butterworth      S. D. Hathaway  
W. G. Chaney      J. C. Hepburn  
L. J. Climent      R. P. T. Jutson  
P. J. Clinton      R. J. Keogh  
N. C. Colby      R. V. Lowman  
R. V. Crawford      Roger McSweeney

Nicholas Medici  
A. W. Melliger  
H. M. Miller  
N. B. Mills  
I. T. Newton  
D. E. Pike  
F. R. Pike  
L. A. Pulley

H. J. Reed, Jr.  
E. R. Saul  
R. E. Simonds  
W. R. Spittal  
F. H. Stansfield  
C. O. Tillstrand  
J. C. Van Weele  
F. H. Willis

Walter Knoop      Joseph Mazzoichi  
R. E. Lafferty      Norman Salz  
Robert MacVeety, Jr.      W. H. Yocom

## CONVENTION RECORD COMMITTEE

John S. Saby, *Chairman*  
E. K. Gannett, *Secretary*

R. G. Ambos      W. W. Eaton  
Victor Azgapietian      J. E. Eiselein  
H. L. Barney      S. M. King  
Ralph Batcher      H. D. Levine  
Carl Berkley      D. S. Little  
Julius Bernstein      J. F. Morrison  
W. H. Burkhart      A. A. Oliner  
W. G. Chaney      C. E. Page  
L. A. DeRosa      G. T. Royden  
M. Dishal      Gustave Shapiro  
Harold Dorschug      Victor Wouk

## TECHNICAL PROGRAM COMMITTEE

Russell R. Law, *Chairman*

R. R. Batcher      C. H. Hoepfner  
W. P. Boothroyd      H. D. LeVine  
J. T. Brothers      J. C. Lozier  
F. C. Cahill      J. L. McLucas  
H. J. Carlin      J. R. Neubauer  
Michel Copel      H. M. O'Bryan  
L. A. DeRosa      A. C. Peterson, Jr.  
Arthur Dorne      O. W. B. Reed  
J. E. Eislein      O. H. Schmitt  
C. L. Engleman      H. E. Tompkins  
G. A. Espersen      Ben Warriner  
M. D. Fagen      Victor Wouk

## PUBLICITY COMMITTEE

E. K. Gannett, *Chairman*  
Lewis Winner, *Vice-Chairman*

John Carroll      T. R. Kennedy  
W. C. Copp      B. F. Osbahr  
E. E. Grazda      Harold Queen  
Jack Hobby      E. L. Robinson

## FINANCE COMMITTEE

J. B. Buckley, *Chairman*

## HOSPITALITY COMMITTEE

Horace Atwood, Jr., *Chairman*  
O. James Morelock, *Vice-Chairman*

John Boyce      R. S. Mason  
F. S. Dellenbaugh      W. W. Menke  
Milton Dishal      G. L. Pellegrinelli  
J. B. Fisher      H. E. Prew  
Frank Frisch      A. G. Richardson  
L. A. Garretto, Jr.      Richard Sanger  
R. L. Kelleher      J. E. Schlener  
J. A. Koehler      Karl Solomon  
R. G. Lynch      C. W. Souder  
M. R. Yeiter

## INSTITUTE ACTIVITIES COMMITTEE

L. G. Cumming, *Chairman*

Ralph Cole      D. D. Israel  
M. S. Corrington      M. E. Kennedy  
G. A. Espersen      A. C. Peterson  
J. J. Gershon      E. A. Post  
A. W. Graf      L. C. Van Atta  
R. A. Heising      Ben Warriner  
J. K. Hilliard      Ernst Weber

## REGISTRATION COMMITTEE

J. F. Bisby, *Chairman*

J. F. Craib      L. W. Garrand  
W. P. Frantz      William Harrison

## IRE NATIONAL CONVENTION HAS WOMEN'S PROGRAM

The National Convention activities will include an outstanding program of social events and women's activities.

## Social Events

A get-together cocktail party will be held from 5:30 P.M. to 7:30 P.M. on March 19 in the Grand Ballroom of the Waldorf. Tickets may be purchased at the door.

The Annual IRE Banquet on March 21 will also be held in the Waldorf's Grand Ballroom. The winners of the awards for 1956 will be honored during the banquet in ceremonies conducted by President A. V. Loughren. The featured banquet speaker will be John V. L. Hogan. Reservations (while they last) may be purchased in advance from the IRE at \$15.00 apiece.

## Women's Program

Registration and headquarters for women's activities will be held in the Regency Suite on the fourth floor of the Waldorf. In addition to the program outlined below, tickets to radio and TV broadcasts will be available gratis.

## Monday, March 19

9:30 A.M.—5:00 P.M.—Registration—Waldorf-Astoria, Regency Suite, Fourth Floor. Get-Together Coffee Hour, 9:30 A.M.—10:30 A.M.  
1:00 P.M.—4:45 P.M.—Complete, interesting guided tour of lower New York, including Chinatown and Statue of Liberty. @\$2.75.

## Tuesday, March 20

8:45 A.M.—5:00 P.M.—All-day scenic bus

trip to West Point, including tour of up-town New York and Hudson Valley, with luncheon at Thayer Hotel, West Point. @\$6.10.

## Wednesday, March 21

9:00 A.M.—11:00 A.M.—Breakfast at Charleston Garden, B. Altman Department Store, followed by a lecture-demonstration on interior decoration. (No transportation.) @\$1.25.  
12:00 P.M.—2:00 P.M.—Luncheon and fashion show, Empire Room, Waldorf-Astoria Hotel. @\$4.50.  
2:30 P.M. Matinee. "Janus" or "Fanny." (No transportation.) @\$4.30.

## Thursday, March 22

9:30 A.M.—Visit to the famous Frick Gallery, with 40-minute lecture. @\$0.60. Total cost of the entire program: \$19.50.

# SCHEDULE OF TECHNICAL SESSIONS

\* Sessions terminate at 12:00 Noon.

	BELMONT-PLAZA	WALDORF-ASTORIA					KINGSBRIDGE ARMORY	
	Moderne Room	Starlight Roof	Astor Gallery	Jade Room	Sert Room	Grand Ballroom	Marconi Hall	Faraday Hall
<b>Monday</b> March 19 2:30 P.M.— 5:00 P.M.	<i>Session 1</i> INSTRUMENTA- TION—I	<i>Session 2</i> MEDICAL ELEC- TRONICS I	<i>Session 3</i> NEW HORIZONS FOR VEHICULAR COMMUNICA- TIONS	<i>Session 4</i> GENERAL COM- MUNICATIONS SYSTEMS	<i>Session 5</i> PROPAGATION	<i>Session 6</i> ASSURING OUR ENGINEERING FUTURE	<i>Session 7</i> INFORMATION THEORY I	<i>Session 8</i> THE EFFECTS OF ENVIRONMENTAL AND OPERATING CONDITIONS ON THE RELIABIL- ITY OF ELECTRON TUBES
<b>Tuesday</b> March 20 10:00 A.M.— 12:30 P.M.	<i>Session 9</i> ULTRASONICS	<i>Session 10</i> AUTOMATIC CON- TROL	<i>Session 11</i> AIR TRAFFIC CONTROL	<i>Session 12</i> TRENDS IN TV EQUIPMENT	<i>Session 13</i> AUDIO TECH- NIQUES	<i>Session 14 *</i> ANTENNAS AND PROPAGATION	<i>Session 15 *</i> SYMPOSIUM ON AIR FORCE COM- MUNICATIONS AND ELECTRON- ICS PROBLEMS AND PHILOSO- PHIES	<i>Session 16</i> MICROWAVE TUBES
<b>Tuesday</b> March 20 2:30 P.M.— 5:00 P.M.	<i>Session 17</i> QUALITY CON- TROL AND RELI- ABILITY STUDIES OF ELECTRONIC EQUIPMENTS	<i>Session 18</i> NUCLEAR IN- STRUMENTATION	<i>Session 19</i> NAVIGATION	<i>Session 20</i> TV TRANSMIT- TING EQUIPMENT AND TECHNIQUES	<i>Session 21</i> HIGH QUALITY SOUND REPRO- DUCTION		<i>Session 22</i> TELEMETERING COMPONENTS	<i>Session 23</i> ELECTRON TUBES
<b>Tuesday</b> March 20 8:00 P.M.— 10:30 P.M.		<i>Session 24</i> SYMPOSIUM: THE U. S. EARTH SATELLITE PRO- GRAM—Vanguard of Outer Space					<i>Session 25</i> COLOR TELE- VISION TAPE RECORDING	
<b>Wednesday</b> March 21 10:00 A.M.— 12:30 P.M.	<i>Session 26</i> MICROWAVES I— General	<i>Session 27</i> ENGINEERING MANAGEMENT TECHNIQUES	<i>Session 28</i> FLIGHT DATA REDUCTION SYS- TEMS	<i>Session 29</i> BROADCAST AND TELEVISION RE- CEIVERS	<i>Session 30</i> CIRCUITS I—Sym- posium on Application of Recent Network Ideas to Feedback System Problems	<i>Session 31 *</i> NUCLEAR EF- FECTS ON ELEC- TRONIC SYSTEMS	<i>Session 32</i> ELECTRONIC COMPUTERS I	<i>Session 33</i> ANTENNAS
<b>Wednesday</b> March 21 2:30 P.M.— 5:00 P.M.	<i>Session 34</i> MICROWAVES II— Ferrites	<i>Session 35</i> DESIGN AP- PROACHES WITH PRINTED WIRING	<i>Session 36</i> OVER-THE-HORI- ZON SYSTEMS	<i>Session 37</i> COLOR TELE- VISION RE- CEIVERS	<i>Session 38</i> TELEMETERING SYSTEMS		<i>Session 39</i> ELECTRONIC COMPUTERS II	<i>Session 40</i> MICROWAVE ANTENNAS
<b>Thursday</b> March 22 10:00 A.M.— 12:30 P.M.	<i>Session 41</i> CIRCUITS II—De- sign and Application of Active Networks	<i>Session 42</i> ELECTRONIC COMPUTERS III— Symposium on the Impact of Computers on Science and So- ciety	<i>Session 43</i> COLOR TELE- VISION	<i>Session 44</i> COMPONENT PARTS I	<i>Session 45</i> INDUSTRIAL ELECTRONICS	<i>Session 46 *</i> INFORMATION THEORY II	<i>Session 47 *</i> MICROWAVES III —Filters	<i>Session 48</i> INSTRUMENTA- TION II
<b>Thursday</b> March 22 2:30 P.M.— 5:00 P.M.	<i>Session 49</i> CIRCUITS III— Network Synthesis Techniques	<b>Empire Room</b> <i>Session 50</i> SOLID STATE DE- VICES	<i>Session 51</i> WHERE IS MEDI- CAL ELECTRON- ICS GOING?—A Symposium in Pre- diction	<i>Session 52</i> COMPONENT PARTS II	<i>Session 53</i> INFORMATION THEORY III		<i>Session 54</i> MICROWAVE INSTRUMENTA- TION	<i>Session 55</i> BROADCAST TRANSMISSION SYSTEMS—New Horizons

## SUMMARIES OF TECHNICAL PAPERS

## SESSION I\*

MON. 2:30-5:00 P.M.

BELMONT-PLAZA  
MODERNE ROOM

## Instrumentation I

*Chairman: W. CULLEN MOORE,*  
*Boonton Radio Corp.,*  
*Boonton, N. J.*1.1. A Transadmittance Meter  
for VHF-UHF MeasurementsW. R. THURSTON, *General Radio*  
*Co., Cambridge, Mass.*

A direct-reading, null-type instrument has been developed for measuring complex transfer characteristics of 4-terminal devices. Forward or reverse transadmittance, transimpedance, voltage gain or loss, and current gain or loss are independently measured in terms of their real and imaginary components, any of which may be positive or negative. The instrument can also measure directly the absolute magnitude of any of these quantities as well as certain interesting combinations of them for which no specific uses have yet been proposed. Devices that may be measured include vacuum tubes, transistors, complete amplifiers, and various passive networks. Theory of operation, methods of verifying accuracy, and results of a few measurements will be described.

1.2. Measurement of Electron  
Tube Admittance Matrix  
Parameters at Ultra-High  
FrequenciesM. M. ZIMET AND SEYMOUR  
FRIEDMAN, *Naval Shipyard,*  
*Brooklyn, N. Y.*

Rapid, accurate, direct-reading techniques for measurement of the admittance matrix elements of the four-terminal active network representation of an electron tube in the uhf and vhf bands are described, together with the results obtained for grounded-grid operated 7 and 9 pin miniature triodes and grounded-cathode 7 pin miniature pentodes. The measurement points were chosen to be the lugs of the associated tube sockets and to include the tube socket effects in the electron tube parameters. The tube mounts were designed to be used in conjunction with a new type of uhf admittance meter.

1.3. Transistor Measurements  
at High Power LevelsS. I. KRAMER AND R. F. WHEELER,  
*Fairchild Guided Missiles*  
*Division, Wyandanch, N. Y.*

This paper discusses a method for plotting transistor characteristics on a cathode ray oscilloscope at high power levels. Equipment is described which is capable of handling peak powers up to 1 kw without the use of unduly

\* Sponsored by the Professional Group on Instrumentation. To be published in Part 5 of the IRE Convention Record

large components. The equipment consists of two independent units. One of these plots current gain versus emitter or base current and the other presents families of collector or transfer curves.

The high capacity, current supplies are obtained through the use of stepdown transformers, and current feedback is used to raise the impedance to the required level. The measurements are made with the aid of a carrier and a modified pulse technique.

1.4. A Transistorized Events-Per-  
Unit-Time MeterHAMILTON CHISHOLM, *Beckman*  
*Instruments, Inc., Richmond,*  
*Calif.*

The Events-Per-Unit Time-Meter described is a digital frequency meter which is completely transistorized. Its circuitry is essentially an analog of a conventional Berkeley EPUT. Silicon junction transistors were used in the application after consideration of both point contact types and germanium junction types. The design of the various counter functions was based upon much empirical information. The latter involved design and construction of test equipment to operate an X-Y function curve tracer. The static characteristics of a substantial number of transistors were obtained at several temperatures covering the range  $-4^{\circ}\text{F}$  to  $125^{\circ}\text{F}$ . Reliable operation at these temperatures was achieved individually for all functions of the counter. A basic problem of count indication for the binary counters was solved by a system of cascading the binaries to obtain the necessary operating potentials for neon indicator lamps. The time base for the instrument is controlled by a modified Pierce 100 kc crystal controlled oscillator using a single transistor. Its stability is one part in  $10^6$  over the temperature range. Frequency division to obtain accurate counting intervals is obtained by cascading binary counting units. A power supply using silicon rectifiers and a germanium power transistor as a series regulator along with a cold cathode gas reference tube provides regulated power for the instrument. The Events-Per-Unit-Time Meter provides all the functions of the conventional vacuum tube counterpart, operates at a frequency of 100 kc and with a power consumption decreased by a factor of 6. Its reliability, though unproved, is potentially improved by a factor of at least 1,000.

1.5. The Application of Magnetic  
Techniques to a Reliable 40 KC  
EPUT Meter DesignD. A. WEINSTEIN, *Beckman*  
*Instruments, Inc., Richmond,*  
*Calif.*

This paper gives an introduction to magnetic devices in general, and also describes developmental reactors which enabled a complete digital Events-Per-Unit-Time Meter to be built. Three vacuum tubes are used—these generate the radio frequency power used as the carriers for the ferromagnetic elements and the magnetic amplifiers. The circuit used in the instrument are described, along with many of the considerations and problems encountered in the design of this instrument.

## SESSION II\*

MON. 2:30-5:00 P.M.

WALDORF-ASTORIA  
STARLIGHT ROOF

## Medical Electronics I

*Chairman: JOHN K. HILLIARD,*  
*Altec Lansing Corp.,*  
*Beverly Hills, Calif.*2.1. The Perception of Direction  
as a Function of Binaural  
Temporal and Amplitude  
DisparityR. J. CHRISTMAN, *Griffiss Air*  
*Force Base, Rome, N. Y.*

This research was instituted in support of RADC developments of direction finding equipment for pulsed rf signals, and concerned the possible application of binaural localization capabilities of human operators. Values of binaural delay and amplitude disparity required to produce an experience of lateral sound localization were determined. Conditions in which disparities acted independently and in combination, both reinforcing and in opposition to each other, were used. Graphs are presented, showing the relative influence of the two variables and the values required for both 75 and 90 per cent reliability of lateral localization.

2.2. An Apparatus for Brain Tumor  
Localization Using Positron  
Emitting Radioactive  
IsotopesS. ARONOW AND G. L. BROWNELL,  
*Massachusetts General Hospital,*  
*Boston, Mass.*

This apparatus was designed to assist in the solution of a specific clinical medical problem, the localization of tumors in the brain. It uses a peculiar property of positron-emitting radioactive isotopes, simultaneous emission of gamma quanta, to provide a high-definition picture of the tumor location in a profile plane. Displacement to right or left is indicated by an unbalance circuit. The detectors are a pair of NaI scintillators, which mechanically scan the patient's head, and automatically print a record of the isotope concentration. The electronic system, which includes some novel circuits, is designed to satisfy this problem as simply as possible. The mechanical construction emphasizes clinical convenience.

2.3. The Application of Automatic,  
High-Speed Measurement  
Techniques to CytologyW. E. TOLLES, R. C. BOSTROM,  
AND H. S. SAWYER, *Airborne*  
*Instruments Lab., Inc.,*  
*Mineola, N. Y.*

\* Sponsored by the Professional Group on Medical Electronics. To be published in Part 9 of the IRE Convention Record.

The Cytoanalyzer, an instrument being developed for high-speed, automatic screening of cytological smears for the early detection of cancer, is based on the distinguishable differences that exist between malignant and normal cells when compared with respect to nucleus size and density. This paper discusses the techniques used to obtain these differences in cell characteristics from the electrical analog of the smear. The design and operation of the measuring and computing circuits used in the instrument, including evaluation test methods and results, are described. The design of the scanning element used to convert the optical information of the smear to a serial electrical current is summarized.

#### 2.4. An Intercommunication System for the Surgical Operating Room

M. M. DAVIS, JR. AND MAITLAND BALDWIN, *National Institutes of Health, Bethesda, Md.*

An intercommunication system for neuro-surgical operating room use has been developed to increase the transfer of intelligence between members of the operating team, to and from recording and observational facilities, both inside and outside the operating room, and to afford surgeon-controlled communication with a patient under local anaesthesia. A number of problems are discussed relating to the special requirement involved in integrating such a system with operating room procedures. Future needs, especially for a wireless system, are discussed with special attention devoted to the limitations imposed by the presence of other sensitive electronic apparatus.

#### 2.5. The Physiograph—A New Instrument for the Teaching of Physiology

L. A. GEDDES, *Baylor University, Houston, Texas*

The paper describes an instrumentation program to provide the medical student with modern instruments to measure and graphically record such important physiological variables as blood pressure, the pull of the three types of muscles, the respiratory movements of the chest and abdomen, the bio-electric signals (EKG, EMG, EEG, ECoG, etc.) and many other quantities. The basic instrument which is capable of performing these and other tasks is a simple three channel physiological recorder based on the well-known principles of data handling. Basically each channel consists of a high conversion efficiency transducer to convert the biological signal to an electrical signal. The electrical signal is amplified by a simple direct coupled amplifier and is recorded by a direct inking pen on a moving paper. With this system, one needs only to use the appropriate transducer to record a particular event.

Twenty of these three channel units called *Physiographs* have been in use for two academic years. Experience has shown that the era of the smoke drum has drawn to a close.

## SESSION III\*

MON. 2:30-5:00 P.M.

### WALDORF-ASTORIA ASTOR GALLERY

#### Vehicular Communications: "New Horizons for Vehicular Communications"

*Chairman:* WILLIAM M. RUST, JR.,  
*Humble Oil & Refining Co.,  
Houston, Tex.*

#### 3.1. Miniturization Techniques Utilized in a Multichannel Crystal Controlled VHF Oscillator

E. M. STRYKER, JR., *Collins  
Radio Co., Cedar Rapids,  
Iowa*

The need for a high stability multichannel vhf oscillator in a very limited space led to the utilization of new packaging techniques to produce an easy to maintain low cost unit. Fifteen miniature mode type crystals operating in the range of 30 to 45 mc along with a printed circuit LC tuner in a frequency multiplying circuit were employed to produce an output providing 18 channels linearly spaced in the frequency range of 66.67 to 123.3 mc. A simple printed circuit switch having extremely good life characteristics was developed.

#### 3.2. A New Concept for Com- munication Vibrator Design

A. B. TOLLEFSEN, JR., *P. R.  
Mallory and Co., Inc.,  
Indianapolis, Ind.*

The communication's industry has, for years, been forced to utilize components designed essentially for the entertainment and allied fields. The rapid expansion of the mobile communications field now places this industry in a position where they can demand components designed to fit their needs. Vibrator Engineers have recognized that the industry requires a vibrator capable of giving long continuous and reliable life handling many times the power used by other fields. This has proven quite a challenge and has resulted in an entirely new concept of vibrator design.

#### 3.3. More Words Per Minute Per Kilocycle

C. B. PLUMMER, *Federal Com-  
munications Commission,  
Washington, D. C.*

The amount of information which may be transmitted over a radio channel of a given width has a close relationship to the complexity of the apparatus involved in its transmission and reception. Virtually every radio service licensed by the Federal Communications Commission utilizes far more radio spec-

\* Sponsored by the Professional Group on Vehicular Communications. To be published in Part 8 of the IRE Convention Record.

trum than needed to convey the necessary intelligence in order to utilize low cost apparatus. There are excellent expansion possibilities in the land mobile services which are today the most inefficient users of our radio spectrum.

#### 3.4. A Vehicular User Looks at the Future

D. E. YORK, *United Fuel Gas  
Corp., Charleston, W. Va.*

The ever-increasing need of vehicular communication to support the operations of industrial and utility services has faced old and new limitations. The limits of frequency spectrum have always been with us and the limits of mobility and flexibility are facing us. Other new and useful applications occur with each major improvement in industrial processes. The user of vehicular equipments must be constantly alert to every new device and technique, which will pace his organization's expansion. This paper will draw upon past experience and the wide horizons of new engineering developments which are fast becoming practical in application.

#### 3.5. Is 960 MC Suitable for Mobile Operation?

C. J. SCHULTZ, *Motorola, Inc.,  
Chicago, Ill.*

This paper presents an analysis of data giving a picture of the operation of 960 mc mobile units in a large metropolitan area. Data presented was gathered under conditions which closely simulate those encountered by industrial vehicles in both urban and suburban areas. The use of data gathered by extrapolating limited information taken under theoretically ideal conditions was avoided since this type of data is inadequate when mobile coverage must be predicted with accuracy.

## SESSION IV\*

MON. 2:30-5:00 P.M.

### WALDORF-ASTORIA JADE ROOM

#### General Communications Systems

*Chairman:* H. P. CORWITH,  
*Western Union Telegraph Co.,  
New York, N. Y.*

#### 4.1. The Place of Communica- tions in Integrated Data Processing

A. O. MANN, *SKF Industries,  
Inc., Philadelphia, Pa.*

The current status of teletypewriter and related communications equipment for integrated data processing at SKF will be described. Further description will be given of the future plans for provision of a complete, national circuitry of teletypewriter. The relationship of such communications equipment to a

\* Sponsored by the Professional Group on Communications Systems. To be published in Part 8 of the IRE Convention Record.

complete computational and control program will be outlined, highlighting our plans for a complete closed circuitry with full feedback. Included in the paper will be descriptions of some new and decidedly novel communications equipment which we have developed in collaboration with A.T. & T. Co. and which exists nowhere else.

#### 4.2. A New Means for Analysis of Communication Equipment and System Performance Using Log-Log Selectivity Curves

EMERICK TOTH, *Naval Research Lab., Washington, D. C.*

When the two sides of a typical selectivity curve for a receiver are averaged and the result plotted on log-log coordinate paper, a single line is obtained. This line will have a characteristic slope which, beyond its "nose" portion, is dependent only on the number of tuned circuits contributing to that particular selectivity curve and the relative attenuation at which the slope is measured. This property can be employed to extract a great deal of useful design and system performance information from weak-signal selectivity, crossmodulation, intermodulation, and desensitization curves. The slopes characteristic of one to twenty resonant circuits in cascaded single or coupled circuit configuration are shown, and analyses of typical cases of crossmodulation, intermodulation, etc., are given. The application of this form of presentation for various purposes, such as determination of permissible frequency and antenna spacing in adjacent channel operation, is discussed.

#### 4.3. Sixteen Channel Time Division Multiplex System Employing Transistors and Magnetic Core Memory Circuits

J. C. MYRICK, *Rixon Electronics, Inc., Silver Spring, Md.* AND  
WALTER E. MORROW,  
*M.I.T., Cambridge, Mass.*

A four-channel time division multiplex system, utilizing vacuum tubes, has been in use for several years. This paper describes a new development, which compresses sixteen standard 60 or 100 word per minute teletype inputs into a time division multiplex system developing an output suitable for use with frequency-shift keying systems. The computer field has been drawn on for ferrite core memory circuits, shift registers, binary count-down circuits, and applications of transistors. The equipment to be described occupies the same rack space, requires far less power input, and is inherently much more reliable than the multiplex equipment currently in use.

An important feature of this equipment is the incorporation of timing facilities based on an oscillator with an inherent stability of one part in ten to the eighth per day or better. This provides highly synchronous operation with infrequent synchronizing pulses.

#### 4.4. Transmitting Tubes for Linear Amplifier Service

R. L. NORTON, *Penta Lab., Inc., Santa Barbara, Calif.*

Increased use of single-sideband transmission has made linear amplifier distortion of considerable importance, because of the serious effects of nonlinear distortion on transmitted bandwidth. The linearity of conventional transmitting tubes designed for telegraphy or high-level modulated service is discussed, and it is shown that certain basic tube structures are capable of satisfactory linear amplifier performance while others are not. Improved transmitting tubes for linear amplifier service are described, and their design principles and performance data discussed.

#### 4.5. Methods of Reducing Frequency Variations in Crystals Over a Wide Temperature Range

L. F. KOERNER, *Bell Telephone Lab., Whippany, N. J.*

In crystal controlled oscillator and filter circuits requiring high precision of frequency, an oven is generally specified to stabilize the temperature of the crystal unit. Where transistors are utilized, the power delivered to the oven may be a large portion of the total power required to operate a complete electrical system. By replacing the crystal unit with a network consisting of the crystal unit, thermistor and appropriate inductors, capacitors and resistors, the frequency variation is reduced to the extent that in many cases an oven is no longer required.

### SESSION V\*

MON. 2:30-5:00 P.M.

#### WALDORF-ASTORIA SERT ROOM

#### Antennas and Propagation—Propagation

Chairman: HENRY G. BOOKER,  
*Cornell Univ., Ithaca, N. Y.*

#### 5.1. Wave Propagation over a 350-Mile Path at 960 MC

I. H. GERKS AND A. J. SVIEN,  
*Collins Radio Co., Cedar Rapids, Iowa*

Considerations affecting the choice of equipment are discussed. The equipment employed in the measurements includes a 1 kw transmitter, a low-noise, narrow-band receiver, parabolic antennas up to 28 feet in diameter, and a recorder capable of indicating quantile levels on a chart or on punched cards. Modulation and diversity combining methods are considered. The median transmission loss at several distances up to 350 miles is compared with predictions. The analysis also includes the type of fading encountered at various distances. A novel method of recording the propagation results is described which makes the analysis of data an almost fully automatic process. Magnetic tape recordings are presented to illustrate the quality of voice signals on multiplex circuits at various distances.

\* Sponsored by the Professional Group on Antennas and Propagation. To be published in Part 1 of the IRE Convention Record.

#### 5.2. Ionospheric Cross Modulation From a 1,000 KW Long-Wave Broadcast Transmitter

E. T. MARTIN AND GEORGE JACOBS, *U. S. Information Agency, Washington, D. C.*

Since the Voice of America long-wave 1,000 kw broadcast station began operating in 1953 at Munich, Germany, on a frequency of 173 kc several instances of ionospheric cross modulation have been observed. This effect, sometimes referred to as the "Luxembourg Effect," is caused by the interaction of radio waves in the ionosphere and can be described as the modulation of the signal from the Munich station impressing itself upon the carrier wave from other powerful broadcast stations operating on different frequencies. Several tape recordings of typical ionospheric cross modulation will be demonstrated and the physical processes thought to be involved will be discussed briefly.

#### 5.3. Atmospheric Refraction of 8.7 MM Radiation

G. R. MARNER AND R. M. RINGEON, *Collins Radio Co., Cedar Rapids, Iowa*

Radiation from the sun has been observed over a period of 10 months with a radio sextant operating at 8.7 mm wavelength. Since the radio sextant automatically positions itself to point at the apparent position of the sun, the refraction experienced by the solar radiation in passage through the atmosphere is obtained. An analysis of data gathered during 98 sunsets is presented. The average refraction as a function of altitude angle is given, together with its rms deviation. Many different types of weather conditions occurred during the observing period, so that discussion of the weather dependence of the refraction is also possible.

#### 5.4. Recent Developments in the Theory of Sea Clutter

MARTIN KATZIN, *Consulting Engineer, Washington, D. C.*

Extensions of a theory of sea clutter based on the small facets of the surface as the scattering elements are discussed. It is shown that the scattering parameter  $\sigma^0$  has the same frequency dependence at low angles and high angles, and that  $\sigma^0$  ultimately must decrease. The high-angle variation is determined mainly by the slope distribution of the facets. With the Cox and Munk slope distribution,  $\sigma^0$  is approximately proportional to wind speed at low angles, but inversely proportional to wind speed at vertical incidence. Measured values of  $\sigma^0$  account for scattering by the entire surface of the sea.

#### 5.5. Radar-Type Propagation Survey Experiments for Communications Systems

R. E. LACY AND C. E. SHARP,  
*Signal Corps Engineering Lab., Fort Monmouth, N. J.*

A technique for conducting rapid uhf and microwave propagations surveys is described. Experiments have been made using the ground-clutter patterns of a radar PPI scope. The results are discussed and illustrated with photographs. It is shown that a radar PPI pattern may be interpreted in terms of the best siting positions with respect to the radar's location as a transmitting or receiving point. This method is independent of the availability of contour maps, or an intimate knowledge of the surrounding terrain. Precise quantitative data of path-transmission loss acquired by this method is limited by knowledge of the reflection characteristics of the contemplated communication sites.

## SESSION VI\*

MON. 2:30-5:00 P.M.

### WALDORF-ASTORIA GRAND BALLROOM

#### Assuring our Engineering Future

*Chairman:* HOWARD L. RICHARDSON, *Sylvania Electric Products, Inc., New York, N. Y.*

#### 6.1. Industrial Research of the Future

E. D. REEVES, *Esso Research and Engineering Co., New York, N. Y.*

Industrial research will grow into a sixteen billion dollar business employing more than one million persons within 20 years. The nation's present research bill is more than four billion dollars. Employees total about 400,000.

Research has already developed into an industry in its own right and today surpasses several large manufacturing activities.

Foreseen is a new era of industrial growth in which technology will come into its own as our most important raw material and the foundation for an ever-expanding economy.

The growth depends, however, on the development of greatly improved techniques and equipment. New techniques will not only lower the cost of producing our expanding technology but will have the added advantage that its growth will not be limited by potential shortages of scientific personnel.

In 1930, total U. S. research costs did not exceed four hundred million dollars; possibly half that much.

The current four billion dollar research bill is slightly over 1 per cent of the Gross National Product, which has been growing at the rate of 3 per cent yearly. Industrial research has been expanding some 10 to 12 per cent annually, almost tripling in size every ten years.

#### 6.2. Human Relations Responsibilities of Engineers

L. W. HOUSTON, *Rensselaer Polytechnic Institute, Troy, N. Y.*

\* Sponsored by the Professional Group on Engineering Management. To be published in Part 6 of the IRE Convention Record.

#### 6.3. The Challenge of Engineering Management

C. H. LINDER, *General Electric Co., New York, N. Y.*

#### 6.4. Education for Engineering Management

ELI SHAPIRO, *M.I.T., Cambridge, Mass.*

The trilogy of science, engineering and population point to an expanding economy in the generation ahead. To manage this expansion wisely requires the preparation of wise managers in increasing numbers. The management education program at the School of Industrial Management is designed to build on a base of science and/or engineering education. The object of the school is to prepare men to take wise and effective action in the management of industrial concerns. The education offered derives from the belief that a successful manager in the modern technological age should understand the principles of science and engineering upon which the application of industry rests. He should know the methods of production and distribution. He should understand as much as possible about himself, the nature of other human beings, and the environment—economic and political—in which he lives. In addition to this body of knowledge, a successful manager should possess the intellectual skill and resilience to deal with the novel situations presented to him by changes in the economic, social and technological situation.

Professor Shapiro will discuss the philosophy and implementation of these objectives at the School of Industrial Management at the Massachusetts Institute of Technology as illustrative of one experiment in management education for engineering.

## SESSION VII\*

MON. 2:30-5:00 P.M.

### KINGSBRIDGE ARMORY MARCONI HALL

#### Information Theory I

*Chairman:* N. MARCHAND, *Marchand Electronic Labs., Greenwich, Conn.*

#### 7.1. Information Theory and Quality Control

JEROME ROTHSTEIN, *Signal Corps Engineering Labs., Fort Monmouth, N. J.*

A basic analogy is described between a communication system and a manufacturing system with the following correspondences between terms: message source and specification, transmitter and means for modifying raw

\* Sponsored by the Professional Group on Information Theory. To be published in Part 4 of the IRE Convention Record.

materials, channel and objects possessing measurable characteristics relevant to specifications, source of noise and cause for rejection, receiver and quality measurement system, ensemble of received messages and lot of manufactured articles of measured statistical quality. The common logical basis of statistical communication theory and statistical quality control, plus the fact that measurement can also be described as communication, assumes particular importance if automation is extended to encompass both quality control and production.

#### 7.2. Coherent Detection of Sinusoidal Signals in Gaussian Noise

K. S. MILLER, *New York University, New York, N. Y.*, AND R. I. BERNSTEIN, *Columbia University, New York, N. Y.*

The problem treated in this paper is that of detecting a weak sinusoidal signal in the presence of Gaussian noise when it is known in advance that if the signal exists it will occur within a given frequency range called the "signal band." With coherent integration there exists the option of dividing the signal band into a large number of integration channels, and thereby obtaining a large signal-to-noise ratio in the channel in which the signal resides, or dividing the signal band into only a small number (or even one) of integration channels. If a large number of channels are employed the opportunities for a false alarm are increased. The detection threshold in each channel must therefore be raised in order to retain a low overall false alarm probability. Raising the acceptance threshold reduces the detection probability in the channel in which the signal is actually present. The question arises as to whether or not the detection test is improved and by how much.

Depending on the value of signal-to-noise ratio before integration and the prescribed over-all false alarm probability, it is shown that in some cases the detection probability decreases as the number of integration channels is increased, reaches a minimum (at a value which has been computed) and then increases monotonically to one. In other cases the detection test improves monotonically as the number of integration channels increases. Quantitative results are presented for a wide practical range of snr before integration, over-all false alarm probabilities, detection probabilities, and number of integration channels.

#### 7.3. Piecewise Quadratic Detectors

RALPH DEUTSCH, *Hughes Aircraft Co., Culver City, Calif.*

The piecewise quadratic detector is characterized by an output response  $V = a(y) + b(y)y + c(y)y^2$ . Complete statistical properties can be found for noise processed by such detectors with isolated input and output filters. Special cases include square law, linear, and perfect limiting detectors.

#### 7.4. A Theory for the Experimental Determination of Optimum Nonlinear Systems

A. G. BOSE, *M.I.T., Cambridge, Mass.*

Following the lines of the Wiener theory of experimental nonlinear system classification a theory is developed for the experimental determination of optimum time-invariant nonlinear filters. The filters are optimum in a weighted mean square sense in which the weighting function is at our disposal. An operator on the past of the input is defined in such a way that, in the experimental setup, we can take advantage of orthogonality to evaluate the classifying coefficients of the optimum system independently.

This paper briefly describes the Wiener theory of nonlinear system classification and then discusses the theory and associated apparatus for the determination and synthesis of optimum nonlinear filters.

### 7.5. Evaluation of Complex Statistical Functions by an Analog Computer

R. R. FAVREAU AND H. LOW, *Princeton Computation Co., Princeton, N. J.*, AND  
I. PFEFFER, *The Ramo-Wooldridge Corp., Los Angeles, Calif.*

This paper presents a technique for experimentally determining a number of statistical functions which are difficult or impossible to evaluate analytically. Technique developed will be described by illustrating its use in evaluating three such functions listed below:

- 1) The probability distribution of time to first passage across a threshold for a Gaussian random variable with a given spectrum.
- 2) The probability distribution for the length of interval between two successive zeros of a Gaussian random variable with a given spectrum.
- 3) The probability that a Rayleigh distributed random variable will fade below a threshold for a given time.

Results obtained for the last two functions will be presented. They agree very well with known analytical results.

## SESSION VIII\*

MON. 2:30-5:00 P.M.

KINGSBRIDGE ARMORY  
FARADAY HALL

**The Effects of Environmental and Operating Conditions on the Reliability of "Reliable" Electron Tubes**

*Chairman: E. K. WIMPY, CBS Hytron Division, Danvers, Mass.*

\* Sponsored by the Professional Group on Reliability and Quality Control. To be published in Part 6 of the IRE Convention Record.

### 8.1. A Basic Study of the Effects of Operating and Environmental Factors on Electron Tubes

W. S. BOWIE, *General Electric Co., Owensboro, Ky.*

A basic study of the effects of operating conditions and environmental factors on the reliability and characteristics of reliable type electron tubes has been conducted. This study was started in 1952 at the General Electric Co. under Contract 36-039 SC42524 with the Evans Signal Laboratory of the Signal Corps and is now nearing completion.

The accompanying papers give the details of the variables which were studied.

### 8.2. The Effects of Shock and Vibration

FRANK WARNOCK, JR., *General Electric Co., Owensboro, Ky.*

The tube types 5670, 6J6W, 5654, 5726, and 6005 were tested under vibration and shock conditions. The tests were conducted on a LAB package tester which gives a random shape wave train type of shock and vibration to the tubes. The lots were operated for 256 hours.

Twenty slides will be shown giving the effects of these tests on the survival rate and on the characteristics.

### 8.3. The Effects of Heater Voltage and Heater Cycling

W. S. BOWIE, *General Electric Co., Owensboro, Ky.*

The types 5670, 6J6W, 5654, 5726, and 6005 were studied for the effects of heater voltage. On each type one lot at each of five voltages was operated to 5,000 hours.

Eighteen slides will be shown giving the effects of these variables on the survival rate and on the major characteristics.

### 8.4. The Effects of Ambient Temperature

P. F. BARNETT, *General Electric Co., Owensboro, Ky.*

The types 5670, 6J6W, 5654, 5726, and 6005 were studied for the effects of ambient temperature. One lot of each type was operated in a temperature-controlled oven and was tested on the test sets with the ambient temperature controlled at the same point for each lot. All other conditions except the temperature were maintained at the specified JAN conditions.

These lots were operated for 5,000 hours. Fifteen slides will be presented to show the effects of these temperatures on the survival rates and on the major characteristics of the tubes.

### 8.5. The Effects of Plate Voltage, Plate Current, and Plate Dissipation

D. E. LAMMERS, *General Electric Co., Owensboro, Ky.*

The types studied under this phase of the contract were the 5670, 6J6W, 5654, 5726, and 6005.

Twelve lots of each type were operated

under various conditions of plate voltage, plate current, and plate dissipation for 5,000 hours.

Thirty slides will be shown giving the effects of these variables on the survival rate and on the major characteristics of the tubes.

### 8.6. The Effects of Pulse Operation

W. U. SHIPLEY, *General Electric Co., Owensboro, Ky.*

The types studied for the effects of pulse operation were 5726, 6J6W, 5814, 5670, and 6AG7. There were five lots of each type which were all operated with 10 microsecond pulse widths. The per cent duty and the peak pulse current were varied from lot to lot to determine the effects of plate dissipation, of peak current, and of duty cycle. These lots were operated for 5,000 hours under these conditions.

Fifteen slides will be shown which will give the effects at this type of pulse operation on the survival rate and on the characteristics of the tubes.

## SESSION IX\*

TUES. 10:00 A.M.-12:30 P.M.

BELMONT-PLAZA  
MODERNE ROOM

Ultrasonics

*Chairman: KARL S. VAN DYKE, Wesleyan Univ., Middletown, Conn.*

### 9.1. Ultrasonic Stroboscope

E. A. HIEDEMANN, *Michigan State University, East Lansing, Mich.*

A brief review of the different types of ultrasonic light tubes, and their applications is followed by a report on a recent study of the special types which can only be used for the study of ultrasonic phenomena. Advantages and limitations of these special stroboscopes are illustrated in the study of Rayleigh phase shift and of other phenomena. A simple method for measuring the part of the period during which a light tube transmits light is applied to the different stroboscopes.

### 9.2. Surface Resonances of Bubbles and Biological Cells

EUGENE ACKERMANN, *Pennsylvania State University, University Park, Pa.*,  
AND T. F. PROCTOR, *Corning Glass Works, Corning, N. Y.*

If a bubble in a liquid is exposed to a sonic field, the bubble may exhibit various types of resonance. Best known is the pulsating mode in which the volume of the bubble changes

\* Sponsored by the Professional Group on Ultrasonics Engineering. To be published in Part 9 of the IRE Convention Record.



periodically. However, other modes exist in which the volume remains constant but the shape of the bubble is altered. These surface modes are characterized by extremely small scattering and absorption cross sections for plane waves and by finite cross sections for divergent or non-uniform sound fields. These modes have been explored both theoretically and experimentally. A movie will be shown demonstrating this effect for air bubbles in water. In the neighborhood of these resonating bubbles large strains will appear within the liquid. These may produce many of the destructive effects associated with "silent" cavitation. Moreover, these resonances are similar to those which may be responsible for the optimum frequencies in the ultrasonic disruption of suspensions of single biological cells.

### 9.3. Electronic Design Considerations in the Application of Piezoelectric Transducers

WILSON BRADLEY, JR., *Endevco, Corp., Pasadena, Calif.*

Design considerations of several electronic amplifiers for use with piezoelectric pickups are discussed in detail. The transducers, in the form of accelerometers, pressure pickups, and force gages, have come into wide use today because of unique self generating and wide frequency range properties of the piezoelectric coulomb generator, as shown by its equivalent circuit. Matching instrumentation electronics must provide the desired signal for an end result of visual, telemetered, or recorded readout and must be adapted to the unique transducer characteristics and their environment as well as the readout devices.

### 9.4. Propagation of Elastic Pulses Near the Stressed End of a Cylindrical Bar

A. H. MEITZLER, *Bell Telephone Labs., Whippany, N. J.*

Longitudinal elastic pulses were produced by reflection of an air shock from the end of a cylindrical bar. The effect of the stress-free lateral surface upon the propagation of the resulting transient strain was studied in a region within several diameters of the impacted end by means of resistance strain gauges in the interior as well as on the surface of bars. A technique of embedded gauges in Lucite bars was used to provide evidence concerning the mechanism by which the lateral surface affects the propagation of an elastic pulse. Strain records from embedded and surface gauges will be presented to demonstrate that the motion of a pressure pulse front perpendicular to and along a free lateral surface is accompanied by the generation of relief dilatational waves as well as shear waves. The observations with the embedded gauges provide the first experimental demonstration of the generated relief dilatational waves and, further, present additional evidence for the generated shear waves.

### 9.5. Transient and Steady-State Response of Ultrasonic Piezoelectric Transducers

E. G. COOK, *Schlumberger Well Surveying Corp., Ridgfield, Conn.*

An analysis is made of the transient and steady-state response of X-cut quartz plates radiating plane waves into a liquid or solid. The results of the analysis are confirmed by experimental data. The effective electrical impedance of the acoustic system is used to measure the steady state performance. The transient performance is obtained by exciting the transducer with a step voltage, a sharp unidirectional voltage pulse, and a sinewave packet. The resulting acoustic waves are studied by use of a high frequency crystal probe. The results of this investigation are used to calibrate ultrasonic resonance-type instruments for thickness measurements, and to obtain short acoustical pulses for flaw detection equipment.

### 9.6. Some Resonator Properties of Synthetic and Doped Synthetic Quartz

A. R. CHI, *Signal Corps Engineering Labs., Fort Monmouth, N. J.*

At-cut resonators fabricated from synthetic quartz grown on CT-cut seed plates, on Z-cut seed plates, on Y-bar seeds, and on AT-cut seed plates were tested. The effect of impurities on the resonator properties of quartz was also investigated. The frequency temperature curves for each family of AT-cuts were plotted. The results indicate that the inflection temperature is higher for all synthetic quartz, in particular for the doped quartz, than for natural quartz. The optimum angle of cut (the ZZ' angle of a rotated Y-cut at which the temperature has the least effect on the frequency of the resonator) is also higher for all synthetic quartz than for natural quartz.

## SESSION X\*

TUES. 10:00 A.M.-12:30 P.M.

### WALDORF-ASTORIA STARLIGHT ROOF

#### Automatic Control

Chairman: JOHN C. LOZIER, *Bell Telephone Labs., Inc., Whippany, N. J.*

### 10.1. Feedback-Controlled Length-Modulated Pulse Generator

J. E. SHEA AND P. F. ORDUNG, *Yale University, New Haven, Conn.*

The principles of feedback have been applied to the problem of the development of a pulse generator in which the length of pulses of uniform height is precisely controlled by an input voltage. This control is accomplished by incorporating a novel pulse generator into a feedback loop. The device operates so as to adjust the length of the pulses between the limits of zero and the repetition period to minimize the averaged difference between the input and the output pulse wave. Thus this de-

vice is a pulsed data system in which regularly taken samples are represented by pulses of uniform height and varying length. The problem of the practical design of the device is considered. In particular, the method of determination of the characteristics of the averaging filter and its design, subsequent to restraints imposed by features of the system, is outlined.

### 10.2. A Nonlinear Noise Suppression Network for Feedback Control Systems

R. L. GORDON, *Sperry Gyroscope Co., Great Neck, N. Y.*

If two different signals are applied to a linear filter simultaneously, and if the frequency spectra of the two signals lie in the same band, the filter will not separate them. However, if a nonlinear filter operates on the differences in characteristics (other than frequency characteristics) it is possible to separate these signals. This paper describes a filter composed of a nonlinear active feedback network which performs this operation. In addition, certain nonlinear concepts pertaining to this type of circuit are discussed.

### 10.3. Measurement and Stabilization of Nonlinear Feedback Systems

G. CASSERLY AND J. G. TRUXAL, *Polytechnic Inst. of Brooklyn, Brooklyn, N. Y.*

Nonlinearities in feedback control systems can frequently be represented by a single, frequency-independent nonlinear element in conjunction with linear transfer functions. This representation (possible for saturation, velocity saturation, backlash, etc.) permits stability analysis with single amplitude and frequency loci. Oscillations resulting primarily from the nonlinearity can be eliminated by model compensation (complementary nonlinear networks in a subsidiary feedback path) with design based on manipulation of the block diagram. Model construction (or simulation of common nonlinearities) is effected with diodes in conjunction with linear networks. This representation simplifies the measurement of nonlinearities, since the describing function is frequency-independent.

### 10.4. Optimum Switching Criteria for Discontinuous Automatic Controls

N. J. ROSE, *Stevens Inst. of Technology, Hoboken, N. J.*

In a discontinuous control the correcting force is switched between two values, say, +1 and -1. Such systems, in their crudest forms simply switch the polarity of the correcting force when the error changes sign and have many undesirable characteristics. By using a more complicated switching rule, with the correcting force depending on both the error and its rates of change, it is possible to improve performance considerably. In fact it is in general, possible to find an optimum switching rule which reduces the error and the derivatives of the error simultaneously to zero in a minimum time. This paper discusses the optimum switching criteria for second and higher order systems.

\* Sponsored by the Professional Group on Automatic Control. To be published in Part 4 of the IRE Convention Record.

### 10.5. The "Reasonableness Check" in Automation

C. H. DOERSAM, JR., *Doerco-Consultants, Port Washington, N. Y.*

The nature of automation with respect to the automatic control of a physical process is reviewed. The boundaries of extent and rate which limit the physical processes are noted. The new concept of "reasonableness concept" is defined in terms of these boundaries. Examples are given which show that in its most elemental form the reasonableness check is common. Its power when extended to more complicated control situations is discussed. An example of one such problem is given. This example uses a digital computer in an automatic control problem. It serves to indicate some of the methods which have been developed from the basic concept.

## SESSION XI\*

TUES. 10:00 A.M.-12:30 P.M.

WALDORF-ASTORIA  
ASTOR GALLERY

### Air Traffic Control

*Chairman:* WALTER W. FELTON,  
*Franklin Inst., Philadelphia, Pa.*

#### 11.1. Symbolic Display System for Air Traffic Control

L. T. HARRIS, *Griffiss Air Force Base, Rome, N. Y.*

A general statement is made concerning the work that has been accomplished to date in the air traffic control area, the inadequateness of present day air traffic control equipment, and a review of various technical developments that hold promise of being effectively used in air traffic display systems.

A plan is presented for a proposed integrated display system capable of providing a nonambiguous display of aircraft identity and position coordinates suitable for high density air traffic control application.

#### 11.2. A New Look at Requirements for Electronic Systems in Air Traffic Control

R. S. GRUBMEYER, *Franklin Institute, Philadelphia, Pa.*

As new equipments and concepts have been developed for the control of air traffic, simulation and other tests have thrown additional light on the detailed requirements for new electronic systems and equipments. Some of these requirements have been met, but others continue to present a challenge to the electronic industry. This paper will highlight the most pressing current requirements, presenting the background information on their development so that alternative solutions may suggest themselves. The primary purpose of the paper

\* Sponsored by the Professional Group on Aeronautical and Navigational Electronics. To be published in Part 8 of the IRE Convention Record.

is to develop in the industry an increased awareness of current needs so that research and development programs can be guided along the most productive lines.

#### 11.3. Traffic Control Electronics Research Goes Modern

E. N. STORRS AND J. L. RYERSON,  
*Griffiss Air Force Base, Rome, N. Y.*

This paper describes the system's research and development program of the inter-center Traffic Control Approach and Landing (TRACAL) team of the Air Research and Development Command of the U. S. Air Force. The basic system engineering concepts of this group are outlined in schematic form and the plans for the Phase I, II, and III traffic control systems are described.

Details of the techniques being applied in the development of enroute traffic control, approach, landing, airfield guidance, and display are discussed.

#### 11.4. An Analysis for Human Flight Control

L. J. FOGEL, *Stavid Engineering, Inc., Plainfield, N. J.*

A mathematical model of some aspects of the aircraft information transfer process is suggested which includes some usually disregarded human operator characteristics, such as anticipation, amplitude quantization and sequential sampling.

Various measures for system performance evaluation are suggested. These may be used to examine the nonstationary probability density distribution of the output-message with respect to the input-signal probability density distribution as a function of time. The output-message is defined as the actual flight path, while the input-signal is taken to be the "intended" airpath—that path described by the probability function obtained from all previous successful performance of the mission phase under consideration. The formulated solution permits both nonlinear and time-varying elements, provided their transduction remains single-valued with time limited memory. This paper presents a general survey of the field and an engineering approach to many highly complex display-control design problems.

#### 11.5. Enhancement of Aircraft Radar Return by Use of Airborne Reflectors and Circular Polarization

J. J. PANASIEWICZ, *Griffiss Air Force Base, Rome, N. Y.*

Airport surveillance and precision approach radars now in operational use are satisfactory for control of reciprocating engine type aircraft of high effective radar cross section. As high performance jet aircraft of relatively low radar cross sections are becoming increasingly abundant, loss of radar target due to low radar reflectivity and precipitation return has become a serious operational problem.

This paper will describe the use of circular polarization as a means of reducing rain return. It is also shown that circularly polarized radiation nullifies the improved radar cross section afforded by normally conventional triple reflection airborne corner reflector. A method of designing corner reflectors is pre-

sented, for enhancement of aircraft radar cross section when the incident radiation is circularly polarized.

#### 11.6. A Three-Dimensional Aircraft Visibility Diagram

ALBERT FEINER AND FRED  
DIAMOND, *Griffiss Air Force Base, Rome, N. Y.*

The usual radar coverage diagram may not predict the actual detectibility of a given type aircraft at a particular range and altitude because of ground clutter. Although the coverage diagram predicts with reasonable accuracy the limits of range and altitude within which signal power of sufficient strength for a given probability of detection will be obtained, a permanent echo received from the same slant range and azimuth may be of sufficient strength to mask the signal received from an aircraft.

Even with a reasonably good MTI radar, the situation is not entirely relieved, despite the lack of presentation of ground clutter on a properly adjusted PPI. For in order that an aircraft at the same slant range and azimuth as clutter be visible, the received clutter signal may not exceed the signal received from the aircraft by more than the subclutter visibility achievable by the MTI. That is, for a particular type of aircraft and a given probability of detection, the criterion for detectibility in the presence of clutter, is not only a minimum signal-to-noise ratio, but also a maximum clutter-to-noise ratio.

This paper discusses a three-dimensional aircraft visibility diagram that accounts for the variation of clutter signal strength, at a specified radar site, with range and azimuth, as well as the variation of aircraft signal strength with range and altitude. Preparation of the diagram, test results, and its theoretical basis are discussed.

Such a diagram can be readily prepared at any radar site with a minimum of time and effort. With this diagram, areas under radar surveillance having poor aircraft visibility for various aircraft are immediately known to a radar operator. It is believed that the diagram is useful for GCA and GCI radars and for the evaluation of MTI capabilities at a given or proposed radar site.

## SESSION XII\*

TUES. 10:00 A.M.-12:30 P.M.

WALDORF-ASTORIA  
JADE ROOM

### Trends in TV Equipment

*Chairman:* SCOTT HELT, *Allen B. DuMont Labs., Clifton, N. J.*

#### 12.1. High Stability Television Synchronization Generator

F. T. THOMPSON, *Westinghouse Electric Corp., East Pittsburgh, Pa.*

A method for obtaining a new order of phase stability in frequency dividers is de-

\* Sponsored by the Professional Group on Broadcast Transmission Systems. To be published in Part 7 of the IRE Convention Record.

scribed. The output of a high frequency crystal oscillator is sampled in order to obtain an output corresponding to a half cycle of a high frequency reference. The application of this method to television results in accurately phased horizontal and vertical synchronization pulses. This method is particularly applicable to television systems utilizing dot interlace.

### 12.2. A Pedestal Processing Amplifier for Television

R. C. KENNEDY, *National Broadcasting Co., New York, N. Y.*

An amplifier is described which incorporates a new type of sync separator that maintains constant sync and clamp pulse amplitudes for composite video signal input level variations of  $\pm 14$  db.

Sync is removed by using these pulses resulting in the derivation of a simple video waveform having a processed pedestal from a composite signal.

### 12.3. A New Electronic Masker for Color Television

J. H. HAINES, *A. B. DuMont Laboratories Inc., Passaic, N. J.*

A new color masker is described having improved performance, convenience, and efficiency. Color-difference mask signal formation is accomplished by a specially designed video mixing transformer, thus permitting major circuit simplification and improved neutral balance stability. Use of the narrow-band mask principle substantially reduces characteristic encoder-decoder crosstalk. The philosophy of masking controls is discussed. Trilinear colorimetric plots illustrate the color shifts produced by incremental changes in the masking controls of various proposals. Unlike other proposals, the masker exhibits a zero-shift color locus for mask amplitude changes.

### 12.4. Reworking the Network or Remote Video Signal

R. R. EMBREE, *KING-TV, Seattle, Wash.*

The network or remote picture signal can be improved locally to a varying extent, depending on the nature of its discrepancies. These improvements will be in the regions of synchronization and gamma. The defective signal is also shown to further deteriorate in passing through amplifiers employing keyed clamps. Pictures included show clearly the results for various deficiencies. Reasons for the inadequacy of presently available gear are discussed. The methods of circumventing many of the overlooked problems are incorporated in the circuitry and external hookup of the sync generator locking device called "Betterlok." This device, workable under more adverse video signal conditions, is described.

### 12.5. A Color Camera for Closed-Circuit Applications

L. E. ANDERSON, *Radio Corp. of America, Camden, N. J.*

Many new applications of TV equipment are looming big on the horizon. Such equip-

ment will contribute untold benefits to the public through the fields of medicine, surgery, and general education which could not be accomplished as effectively by other means.

A small TV color camera with its supplementary equipment which will provide a complete operating system for closed circuit use will be described.

Many uses for such a camera system will undoubtedly be found in addition to those already mentioned, which will extend the scope of operations of many businesses and institutions.

Photographic slides will be used to show the physical layout of the camera, and the camera system. A series of color slides will be used to illustrate one application where this system was demonstrated for instructional purposes. In this application, the specialist performs and the action is viewed by a large audience at a remote point.

## SESSION XIII\*

TUES. 10:00 A.M.-12:30 P.M.

### WALDORF-ASTORIA SERT ROOM

#### Audio Techniques

*Chairman: HUGH S. KNOWLES, Knowles Electronics, Inc., Franklin Park, Ill.*

### 13.1. A Simplified Procedure for the Design of Transistor Audio Amplifiers

W. W. WELLS AND A. E. HAYES, JR., *North American Aviation, Downey, Calif.*

A simplified procedure for the design of transistor audio amplifiers has been developed. This procedure involves the use of approximate equations which have been derived from matrix algebra, in conjunction with special characteristic curves for the  $h$  parameters of the transistor to be used in the circuit. The equations were derived for practical circuits using external base, emitter, and collector resistors. The effect of changes in circuit constants can be easily visualized with a minimum of computation, thus facilitating the optimization of the design.

The discussion will be divided into two parts. The first part is concerned with the derivation of the exact form of the equations using the  $h$  parameter notation recommended by the joint AIEE-IRE task force 7.7.2. The second part of the discussion presents approximate forms of the equations which are valid for a wide range of practical circuits and which lead to a considerable simplification in the design procedure. The method of plotting transistor parameters in a form useful with the approximate equations is also presented together with sample characteristic curves for representative transistors. Finally, some examples of actual circuit designs utilizing the new procedure will be discussed.

\* Sponsored by the Professional Group on Audio. To be published in Part 7 of the IRE Convention Record.

### 13.2. An Audio Flutter Weighting Network

F. A. COMERCI, *63 Carlton Terrace, Nutley, N. J.*

In this paper listener preference rankings of selected samples of program containing many types of flutter will be compared to measurements of the same flutter using a meter weighted with respect to flutter rate in accordance with the threshold of flutter perceptibility. It will be shown that the correct weighting curve varies with the level of flutter and modifications should be made to the flutter meter in order to obtain objective rankings of various types of flutter which will agree with subjective rankings of program containing the same type of flutter.

### 13.3. A Flutter Meter Incorporating Subjective Weightings

M. A. COTTER, *Consumers Union of the U.S., Inc., Mount Vernon, N. Y.*

An instrument is described which incorporates flutter rate weighting networks and utilizes a true rms indicating meter. Another feature is an aperiodic fm detector utilizing a pulse counting technique, which permits using a wide variety of carrier frequencies for flutter measurement, as well as direct frequency (or medium) speed indication. The rms indicating meter incorporates a control response damping characteristic. The instrument shows little aging drift and good stability to calibration. The unit can be readily constructed from standard components.

### 13.4. Performance Measurements of Magnetic Tape Recorders

J. B. HULL, *Ampex Corp., Redwood City, Calif.*

The faithful recording and reproduction of broadcast programs on magnetic tape depends upon the proper adjustment of the azimuth of the heads and the correct adjustments of equalization. Routine preventative maintenance considerations should include such over-all performance measurements which can be quickly made with standard test tapes.

Standard test tapes are available which provide signals for the adjustment of head alignment, and the measurement of frequency response and flutter. Techniques for using the test tapes and test equipment will be explained.

The equipment and the procedures used for recording standard tapes will also be described.

### 13.5. A 3,000 Watt Audio Power Amplifier

A. B. BERESKIN, *Univ. of Cincinnati, and the Baldwin Piano Co., Cincinnati, Ohio*

A 3,000 watt audio power amplifier has been developed using the Bereskin Power Amplifier Circuit described at the 1954 IRE National Convention and in the March-April 1954 issue of the IRE Transactions on Audio. Solutions were found for some interesting problems that arose in this connection. A unit capable of de-

living more than 3,000 watts with less than 2 per cent distortion over a 400-6,000 cycle frequency range was developed. The design procedure and test data on the final unit will be discussed.

## SESSION XIV\*

TUES. 10:00 A.M.-12:30 P.M.

### WALDORF-ASTORIA GRAND BALLROOM

#### Antennas and Propagation

Chairman: GEORGE SINCLAIR,  
*Sinclair Radio Labs., Ltd.,  
Ontario, Canada*

#### 14.1. A Theory of Scattering by Non-Isotropic Irregularities with Application to Radar Reflections from the Aurora

H. G. BOOKER, *Cornell Univ.,  
Ithaca, N. Y.*

A model of the distribution of ionization in an aurora is developed that can explain the aspect sensitivity of radar echoes obtained at vhf during auroral activity. Even when the radar is in the midst of a zone of auroral activity, echoes are obtained only from low angles of elevation in roughly the northern quadrant. However, both the horizontal and vertical angles over which echoes are obtained increase significantly as frequency is decreased from 100 to 25 megacycles per second. These observations can be explained in terms of columns of ionization parallel to the earth's magnetic field. The size of the columns must however be much smaller than suggested by Chapman or by Booker, Gartlein, and Nichols. The column size required is of the order of 40 meters in length and one meter in diameter, smoothed so as to avoid discontinuities at the surfaces. It is quite doubtful whether the formation of such short columns of ionization can be associated directly with the formation of visual rays, even though the same axis of symmetry is involved in both cases. The size of irregularities required to explain the observations is in fact of the order of magnitude likely to be involved in atmospheric turbulence, and it is quite likely that the earth's magnetic field could create substantial non-isotropy in the associated irregularities of electron density. Thus the strength of auroral echoes and their aspect sensitivity could be entirely explained as backscatter arising from non-isotropic atmospheric turbulence in an E-region having a maximum electron density about a hundred times the normal value. Simple turbulence cannot however explain the remarkable fading phenomena associated with auroral reflections.

#### 14.2. Correlation of Radar Sea Clutter on Vertical and Horizontal Polarizations with Wave Height and Slope

\* Sponsored by the Professional Group on Antennas and Propagation. To be published in Part 1 of the IRE Convention Record.

#### F. C. MACDONALD, *Naval Research Laboratory, Washington, D. C.*

Extensive radar sea clutter measurements were made in October, 1955 by the Naval Research Laboratory; simultaneously heights and slopes of sea waves were measured by the Woods Hole Oceanographic Institution.

The radar tests produced accurate data on the variation of sea clutter with angle of incidence up to angles of 60° (with the horizontal) for the radar frequencies of 1,250, 3,300, and 9,300 mc for both horizontal and vertical polarization. The radar data convincingly demonstrate the existence and importance of the indirect illumination of the waves by forward-reflected energy, even for large angles of incidence. Some information of the depolarization of the energy by the sea surface is presented.

The Woods Hole Oceanographic Institution compiled the distribution of the frequency of occurrence of wave height and wave slope in both the upwind/downwind direction and the crosswind direction. The correlations of these heights and slopes of the water surface with the radar echo in the upwind/downwind and crosswind directions are exhibited.

#### 14.3. Precipitation Particle Impact Noise in Aircraft Antennas

R. L. TANNER, *Stanford Research  
Inst., Menlo Park, Calif.*

Antennas under dielectric surfaces on aircraft flying in ice clouds or snow experience severe noise. It was originally assumed that this noise was due entirely to disruptive discharges occurring as a result of the accumulation of charge on the surfaces. Coating the surfaces with slightly conductive coatings, however, while eliminating the discharges, failed to eliminate the noise.

The present paper proposes a theory for a mechanism of noise production which depends upon the impact of individual particles and which is unaffected by the presence of a conductive coating on the dielectric surfaces. Experiments confirming the theory, involving flight tests and a unique laboratory set-up combining a small high velocity wind tunnel and an ice fog chamber, are described. Implications of the theory with regard to the design of aircraft antennas are discussed.

#### 14.4. Analysis of Conical Scan Antennas for Tracking

J. B. DAMONTE AND D. J.  
STODDARD, *Dalmo Victor  
Co., San Carlos, Calif.*

A majority of the radar tracking systems now in operation or under design employ a conically scanning antenna system to gather target position data. An exact analysis of the radar transmission and reception problem, including such effects as target simulation, modulation, and demodulation distortion, etc. becomes unnecessarily complex for application to antenna design. The analysis described in this paper is approximate and is intended for the antenna designer who must translate several tracking requirements into antenna design parameters.

The generation of a radar error signal suitable for tracking purposes is analyzed by assuming an ideal antenna beam shape which has been corrected at the half-power points.

By applying a Fourier series of expansion scheme, the fundamental and higher order terms of the error signal are derived. The error signal can be described in terms of either db difference or per cent modulation. The analysis also yields an expression for the slope of the error signal. These tracking parameters can be related to aperture, beam crossover level and half-power beamwidth in a very simple manner. Design curves which quickly allow the antenna designer to calculate error signal and error signal slope from beam crossover level and aperture, or vice-versa, are included. The analysis can be reversed and used as a synthesis technique. Experimental verification of the theory has been completed and a comparison of theory and experiment is presented.

#### 14.5. Corrections to Current Distributions on Curved Reflectors

ROBERT PLONSEY, *Univ. of  
California, Berkeley, Calif.*

The specific problems of diffraction by a half plane, and by a circular strip with a line source at its center of curvature are considered. It is shown how the geometrical optics current can be corrected by the addition of an equivalent line current at each edge. In each case the "line current" is determined by the incident field at the edge. The field of the line current is non-isotropic; its directional gain is determined. The line currents do not greatly affect the total pattern indicating that the main character of the diffraction can be obtained from the geometrical optics currents. Experimental results for a circular reflector with a line source at its center are given.

## SESSION XV\*

TUES. 10:00 A.M.-12:30 P.M.

### KINGSBRIDGE ARMORY MARCONI HALL

#### Symposium on Air Force Com- munications and Electronics Problems and Philosophies

Moderator: J. E. KETO, *Wright Air  
Development Center, Dayton, Ohio*

USAF Operational Members: Maj.  
Gen. G. A. BLAKE, Brig. Gen. H. E.  
NEAL, Col. R. O. S. AKRE, Col.  
J. B. BESTIC, Col. F. DONKIN

USAF Research and Development  
Members: Col. G. T. GOULD JR.,  
H. DAVIS, L. HOLLINGSWORTH, J. E.  
KETO

\* Sponsored by the Professional Group on Military Electronics. To be published in Part 8 of the IRE Convention Record.

## SESSION XVI\*

TUES. 10:00 A.M.—12:30 P.M.

KINGSBRIDGE ARMORY  
FARADAY HALL

## Microwave Tubes

Chairman: GEORGE A. ESPERSEN, *Philips Labs., Irvington-on-Hudson, N. Y.*

## 16.1. An Investigation of a Traveling-Wave Tube with an External Slow-Wave Structure Using Lumped Circuit Elements

A. R. MATTHEWS, C. T. SAH, AND K. R. SPANGENBERG, *Stanford University, Stanford, Calif.*

This report describes an investigation of a traveling-wave tube with an external slow wave structure using lumped circuit elements connected as conventional filter circuits. The mechanical arrangement permits a variety of circuits to be tested. The low pass  $m$ -derived filter is examined in detail as a slow-wave structure. Both experimental and theoretical results are presented to describe the electronic performance as a backward-wave oscillator, backward-wave amplifier, and forward-wave amplifier. The frequency region of experimental operation is from 80 to 457 mc.

## 16.2. Behavior of Hollow Beams in Radial Electrostatic Fields

L. A. HARRIS, *General Electric Co., Schenectady, N. Y.*

Trajectories are calculated for the inner and outer edges of tubular electron beams in radial electrostatic fields. The beams start with zero thickness and have uniform axial velocity. Special cases considered include a beam inside a single drift tube and a beam between coaxial drift tubes. Both diverging and converging beams are treated in strong and weak radial fields. It is shown that strong radial fields effectively reduce the space-charge spread and at the same time deflect the beam. Calculated results for a particular beam are presented as an example for each of these cases.

## 16.3. Microwave Transmitter Tuning by Rapid-Interchange, Fixed-Frequency Klystrons

R. A. LAPLANTE, *Philips Laboratories, Irvington-on-Hudson, N. Y.*

This paper describes a high-power, fixed-frequency klystron oscillator which, through its features of rapid-interchangeability, stability, reliability, low cost, and long life, appears to be a very useful high-power source.

\* Sponsored by the Professional Group on Electron Devices. To be published in Part 3 of the IRE Convention Record.

Transmitter frequency can be changed in seconds to a predetermined value with no monitoring required, simply by "plugging-in" a different fixed-frequency klystron.

The advantages and limitations of the fixed-frequency oscillator are given, and a comparison is drawn between the tuning procedures required for three klystron types of 100 watt cw power output at X-band.

## 16.4. Design and Performance of Low Noise Guns for Traveling-Wave Tubes

R. C. KNECHTLI AND W. R. BEAM, *Radio Corp. of America, Princeton, N. J.*

The design and performance of a low noise gun for beam-type amplifiers is discussed in this paper. A simple and general design procedure for low noise guns also is presented, with emphasis on gun "flexibility." With a "flexible" gun of the type considered, the noise figure of an amplifier is minimized by simple adjustment of electrode potentials; the distance between gun and input of the rf interaction region is not critical; neither are electrode spacings in such a gun.

## 16.5. Backward-Wave Oscillators

W. MENKE, *Sperry Gyroscope Co., Great Neck, N. Y.*

This paper presents a summary of the characteristics of backward-wave oscillator tubes. It answers typical questions about the why and how of the backward-wave principle. Operation of the "O" and "M" types BWO is described and compared and the range of usefulness of each is discussed.

The performance of backward-wave oscillators is illustrated in terms of experimental results on an S band, "O" type tube. Of interest to the systems engineer or experimenter are the tuning curves, tuning rates, pulse characteristics, frequency pushing, frequency pulling, spectrum purity, noise power, and power supply requirements typical of this tube type. From these, systems applications can be evaluated in terms of what this tube type can reasonably be expected to do.

## 16.6. Backward-Wave Oscillators for Low Voltage Operation

W. L. BEAVER, *Varian Associates, Palo Alto, Calif.*

Several aspects of the design of backward-wave oscillators for low voltage operation are considered. Besides the obvious advantage of reduced power supply requirements, such a design results in a slow-wave structure which is physically short in length. This tube can thus be inherently rugged and conservative of magnetic field. A helix type tube is described which provides local oscillator or signal generator power and which tunes the 8.2 to 12.5 kmc frequency range with a voltage variation of 150 to 600 volts. The focusing field may be supplied by either a permanent magnet or a low power electromagnet.

## SESSION XVII\*

TUES. 2:30-5:00 P.M.

BELMONT PLAZA  
MODERNE ROOMQuality Control and Reliability  
Studies of Electronic  
Equipments

Chairman: JEROME R. STEEN, *Sylvania Electric Products Inc., Batavia, N. Y.*

## 17.1. Achieving and Analyzing Operational Reliability with Equipment of Imperfect Intrinsic Reliability

W. F. LUEBBERT, *Stanford Univ., Stanford, Calif.*

A distinction is made between operational reliability and intrinsic reliability, primarily to show how the factors which determine reliability of performance can be influenced by the equipment user. It is definitely possible to achieve high operational reliability using equipment of low intrinsic reliability, although it may not always be economically or militarily practical to do so. A philosophy for the achievement of operational reliability is presented in the following framework: 1) intrinsic reliability of equipment; 2) failure inhibition; 3) failure anticipation, prediction and prevention; 4) failure detection and isolation; 5) functional replacement or repair of failures; and 6) minimization of effects of failures.

The equipment user usually has a number of "degrees of freedom" in his operational, maintenance, supply, and replacement policies which can vitally affect operational reliability. However, full advantage is seldom taken of opportunities for achieving increased operational reliability by control of these policies. Powerful mathematical techniques are available and readily adapted to analysis of the opportunities for obtaining increased operational reliability. Various techniques are mentioned and one which is particularly well adapted to a class of situations of particular military importance is treated in some detail.

## 17.2. Some Reliability Aspects of Systems Design

FRED MOSKOWITZ AND J. B. MCLEAN, *Griffiss Air Force Base, Rome, N. Y.*

This report uses elementary principles of probability theory and a systematic development is presented which leads to formulas, charts, and guide rules for engineers involved in the design of systems and equipments. Examples are given which illustrate the use of the formulas and the principles derived.

This study attempts to show that when the problem is present of obtaining reliable equipment which consists of unreliable parts, the solution is redundancy. Complexity by itself need not necessarily lead to unreliability if complexity is used correctly.

\* Sponsored by the Professional Group on Reliability and Quality Control. To be published in Part 6 of the IRE Convention Record.

Two very simple redundancy schemes are described and analyzed. It is shown that it is possible to obtain a desired reliability at relatively reasonable cost in terms of increased size and weight.

### 17.3. Training for Quality Control

C. J. QUIRK, *Allen B. DuMont Labs., Inc., Clifton, N. J.*

A training program for quality control, to be effective, must, of necessity be broad in scope.

This paper describes a one year, three phase (Introductory-Intermediate-Advanced) program which was successfully conducted by quality control at DuMont.

Basic quality control procedures interleave with practical manufacturing problems were covered in detail. Methods of presentation were varied to add interest. Individual and group participation in demonstrations were encouraged.

Such widely separated fields as human relations and hand soldering were covered in detail, thereby exemplifying the broad scope of an effective quality control operation, which is spelled out in this training program.

### 17.4. A Bombing System Reliability Program

R. L. WENDT AND M. H. SMITH,  
*Sperry Gyroscope Co., Great Neck, N. Y.*

This paper discusses the establishment of a reliability program for the Sperry K-Series Bombing System used in B-36, B-47, and B-52 aircraft.

The system is first briefly described. This is followed by a discussion of the operation of the failure reporting system. A section on data analysis provides sample reliability calculations, together with certain actual K-System component reliability values. Graphs of malfunction rates and reliability indexes are presented. The operational factors affecting reliability are discussed, as are the engineering product improvement programs that have led to increased reliability. Finally, the results and benefits of the program are summarized.

### 17.5. A Reliability Department Operation for Production Missiles

E. F. DERTINGER, *Bendix Products Division—Missiles, Mishawaka, Ind.*

For the Talos missile program, a practical and effective approach to reliability was necessary, since the missile was already in early production. Time did not allow for the long-range "design evaluation" or "component test and improvement" reliability approaches; reliability improvement in a short time period was essential. For this reason, the decision was reached that design circuitry and component parts chosen for this missile must be accepted, in the belief that most of these component parts would do the job expected of them. Every part in the missile was to be respected as being reliable until factory, field, and statistical tests proved otherwise. A "Reliability Department" was established as the focal point of the missile reliability program. It was the job of this department to

continuously monitor missile quality, to ascertain which components were unreliable, which circuitry was questionable, and to conduct a continuous quality education program.

## SESSION XVIII\*

TUES. 2:30-5:00 P.M.

### WALDORF-ASTORIA STARLIGHT ROOF

#### Nuclear Instrumentation

Chairman: M. A. SCULTZ,  
*Westinghouse Electric Corp., Pittsburgh, Pa.*

#### 18.1. Some Transistor Circuits Used in a Magnetic Core Type Kicksorter

F. S. GOULDING, *Atomic Energy of Canada, Ltd., Ont., Can.*

The essential features of circuits required in a magnetic core kicksorter are discussed and the system used in the new Chalk River kicksorter is described briefly. The methods employed to reduce the number of vacuum tubes to a minimum are then dealt with and transistor circuits employed for timing operations and temporary storage are described. These circuits all use a new type of basic circuit element employing a pair of high frequency transistors which, with suitable choice of components, may operate as a bistable, astable, or oscillating element. Analysis of this circuit element is the main purpose of the paper.

#### 18.2. Punch Card Recording and Multiple Counting Data

H. D. LEVINE AND HENRY SADOWSKI, *U. S. Atomic Energy Commission, Health and Safety Laboratory, New York, N. Y.*

The system will process data from as many as 100 counting systems by channeling a complete set of information on a given sample into a central IBM card punch. Automatic interrogation of individual counters permits the elimination of manual techniques and the avoidance of the human error factor. Each punch card carries detailed information on the number of the sample, the character of the sample, activity, counting geometry of the counting system, counting time, and other related data. Most circuits were redesigned to eliminate vacuum tubes and apply transistor and glow counter techniques.

#### 18.3. Instrument Opportunities in Nuclear Systems

VICTOR PARSEGAN, *Rensselaer Polytech Institute, Troy, N. Y.*

\* Sponsored by the Professional Group on Nuclear Science. To be published in Part 9 of the IRE Convention Record.

Nuclear systems were provided with simple and insufficient adaptations of older instruments. An area remains to be explored to develop new detector elements, more effective integration of instruments for automatic operation, and improved analytic and control concepts and devices. Some of these will be discussed.

### 18.4. Control Aspects of Boiling Water Power Plant

W. C. LAPINSKI, *Argonne National Laboratory, Lemont, Ill.*

### 18.5. Control and Automatic Startup of the Geneva Conference Reactor

E. P. EPLER AND S. H. HANAUER,  
*Oak Ridge National Laboratory, Oak Ridge, Tenn.*

The Geneva Conference Reactor was operated in Geneva, Switzerland, as part of the United States Exhibit at the International Conference on Peaceful Uses of Atomic Energy. Because of the unique conditions of public access, display, and operation by untrained visitors, the usual instruments and controls were augmented by new features, including push-button automatic startup to a predetermined power. To accomplish this, period information was obtained from the counting-rate channels, and rod control modes were altered to take advantage of the increased information. The reactor starts smoothly, without needing operator attention, from source level to its full power of 100 kw.

## SESSION XIX\*

TUES. 2:30-5:00 P.M.

### WALDORF-ASTORIA ASTOR GALLERY

#### Navigation

Chairman: WILLIAM T. CARNES, JR.,  
*Aeronautical Radio, Inc., Washington, D. C.*

#### 19.1. A Radiometric Inertial Reference System

V. W. BOLIE, *Collins Radio Co., Cedar Rapids, Iowa*

Although considerable progress has been made in the development of numerous radio navigation systems, all such systems are of an open-loop nature in the sense that they are not self contained. Emphasis on self-sufficiency has preserved the basic features of long-established celestial navigational techniques and also has led to many recent accomplishments such as the development of the small, rate-integrating

\* Sponsored by the Professional Group on Aeronautical and Navigational Electronics. To be published in Part 8 of the IRE Convention Record.

gyro for inertial navigation systems. Recent studies in microwave radio astronomy have already shown the feasibility of an all-weather tracker for the sun and moon. The microwave tracker provides good long-period information pertaining to the relative position of a celestial reference axis. In a complementary manner which is optimized from the information-theory point of view, the basic principles have been developed for combining the long-period information from the microwave tracker with the short-period information from the inertial reference gyro. The paper contains an outline of the theory of the microwave tracker, the analysis of the servo system, and a discussion of the effects of various parameters, such as antenna aperture and receiver noise-figure on the over-all system performance.

### 19.2. Analytical Prediction of Missile Guidance Accuracy

W. E. MATHEWS, *Hughes Aircraft Co., Culver City, Calif.*

A general analytical solution for the miss distance of a homing missile using only line-of-sight information for guidance is presented. The result is obtained directly from a linearized block diagram of the problem without calculation of any of the rest of the missile trajectory. More generally, the paper can be viewed as presenting an analytical method for determining the response of certain linear feedback systems with nonconstant parameters. The method involves determination (in closed form) of a characteristic response function for the varying-parameter system, from which the response to arbitrary inputs can be found by the usual inverse Laplace transform procedure.

### 19.3. Considerations Affecting the Choice of a Long-Range Navigation System

SIDNEY ROSENBERG, *Griffiss Air Force Base, Rome, N. Y.*

An analysis is made of the factors which affect the range, accuracy, and reliability of available and proposed radio navigational aids for long-range operation in the light of the most recent investigations and requirements of the Air Coordinating Committee. Considerations affecting the "optimum" choice of frequencies for two types of systems are presented based upon the most current operational information of radio wave propagation. A brief description of the principles involved in several representative cw and pulse types of radial, circular and hyperbolic position fixing aids are discussed. A comparison is then made of pertinent operational and technical characteristics of these different radio aids leading to the choice of a possible general purpose system for civil and military applications. Consideration is also given to the possible improvement in the tolerable signal-to-noise ratio, and consequent range extension, of these systems by the application of cross-correlation, coherent, or synchronous detection techniques.

### 19.4. Doppler Type High-Frequency Radio Direction Finder

J. A. FANTONI AND R. C. BENOIT, JR., *Griffiss Air Force Base, Rome, N. Y.*

This paper deals with the development and the fabrication of a high-frequency radio direction finder based on Doppler's principle for wave motion as applied to radio waves.

The resulting model was designed and fabricated by the General Electric Corp. for Rome Air Development Center embodying the design parameters evolved through the joint Air Force and Signal Corps efforts and is primarily designed to cover the frequency range of 1-30 mc. The antenna system consists of 31 monopoles having an array diameter of 150 feet. The relative phase of the signals induced in each antenna of the circular array is determined by the direction of arrival of the signal. A mechanical scanning switch capacitively couples the signals from adjacent antennas and combines them in succession to produce a frequency modulated signal. The phase of the modulation envelope of this signal is measured to determine the bearing of the received signal.

A detailed presentation is given of the basic principles, over-all system parameters, and the model performance characteristics. Of the several components comprising the system, discussion is given of the radio frequency switch, magnetic signal storage device, and the bearing indicator.

The rt switch design permits the continuous high speed scan of the antenna array and the operation of one to four DF receiver-indicators, thus permitting the simultaneous direction finding on up to four frequencies employing the single antenna array. The signals from adjacent antennas in the array are combined in the switch in a manner described as "linear-blended" switching.

An instantaneous storage device employing a magnetic memory drum is included as part of the developed system in order to permit the continuous signal bearing presentation during periods of intermittent signal reception and short duration signal transmissions. Reception of a new signal instantaneously replaces the old.

Performance tests show that the system instrumental error is approximately  $\pm 1\frac{1}{2}^\circ$  and the over-all bearing accuracy including propagation or transmission effects is in the order of  $\pm 1^\circ$ . In general, the bearing accuracy is considered superior to that of other systems, such as the Adcock direction finder.

### 19.5. U.S.A.F. UHF Direction Finding Facility

R. C. BENOIT, JR. AND J. A. FANTONI, *Griffiss Air Force Base, Rome, N. Y.*

This paper is concerned with the theory of operation, development, physical, and electrical description and performance of a uhf ground based direction finding facility to fulfill U.S. Air Force requirements in the frequency range of 225 to 400 mc for operation in conjunction with radio signals emanating from high performance type aircraft.

The equipment described provides automatic, essentially instantaneous bearing information on any one of 10 pre-set channels of 1,750 frequencies within the frequency range of 225 to 400 mc and is capable of complete remote operation from a distance of five miles or less over a four wire telephone cable. The average bearing accuracy is on the order of  $\pm 1\frac{1}{2}^\circ$  and the usable bearing sensitivity is 1 to 5 microvolts per meter over the frequency range of the equipment.

The antenna system differs considerably from conventional concepts formerly employed in the field of radio-direction finding. A height diversity system, consisting of two individual identical antennas in conjunction with a com-

parator which automatically selects the proper antenna, is employed to minimize the effects of multipath propagation. A single antenna system covers the entire 225 to 400 mc range.

Each individual antenna consists of a stationary dipole about which a reflector rotates at 1800 rpm thus modulating the received signal at 30 cps. A reference voltage generator is rotated in synchronism with the reflector and the phase of the antenna modulation is compared with the phase of the reference voltage to indicate the direction of arrival of the signal.

This equipment has been accepted by the U.S. Air Force and is being operationally utilized in the Continental United States and at overseas bases.

### 19.6. Colocation of TACAN VOR-DME Systems

P. E. RICKETTS, *Griffiss Air Force Base, Rome, N. Y.*

With the declassification of the TACAN System, many factors concerning the implementation of this facility for normal service may be publicized. This paper enumerates the various requirements for siting, installation, operation, and maintenance of the TACAN ground equipments. Specifically, the investigation for the operation of the TACAN and VOR-DME facilities at the same site is reported, indicating the extent of the investigation, the optimum configuration of the installation, and the effects of each facility upon the performance of the other.

## SESSION XX\*

TUES. 2:30-5:00 P.M.

WALDORF-ASTORIA  
JADE ROOM

TV Transmitting Equipment  
and Techniques

Chairman: J. B. EPPERSON,  
*Scripps-Howard Radio,  
Inc., Cleveland, Ohio*

### 20.1. High-Gain Antenna Arrays for Television Broadcast Transmission Using a Slotted Ring Antenna

ANDREW ALFORD AND H. H. LEACH, *Alford Manufacturing Co., Boston, Mass.*

The paper deals with high gain antenna arrays, both directional and omnidirectional, which utilize a slotted ring antenna. The theory of operation of the slotted ring antenna and the various parameters that can be used to control the frequency range of operation as well as the impedance characteristics are discussed.

Several applications of the slotted ring antenna in commercial television broadcasting including the use of high gain omnidirectional slotted ring antenna arrays with low power

\* Sponsored by the Professional Group on Broadcast Transmission Systems. To be published in Part 7 of the IRE Convention Record.

transmitters to achieve authorized ERP's are shown.

The variety of horizontal patterns obtainable by directionalizing the slotted ring antenna with relatively simple structures are discussed. Measured horizontal patterns are included showing patterns which conform to the 10 db rule of the FCC for this country as well as several special patterns with extremely high gains and with considerably deeper nulls.

### 20.2. Self-Diplexing Antenna for TV Transmitters

C. B. MAYER AND P. M. PAN,  
*General Electric Co.,  
Syracuse, N. Y.*

This paper describes a novel TV self-diplexed transmitting antenna. The commonly used diplexing equipment necessary to isolate the two transmitters has been eliminated by the use of two orthogonal modes of transmission in a circular waveguide formed by the mast. Energy is coupled to the antenna from the two modes by means of probe coupling and the signals are isolated on antenna due to radiation loss and the use of cross-wound twin helices. The isolation is greater than 23 db over a wide range of frequency band. The patterns are essentially the same as that of the single helical antenna. A two-bay helical antenna was constructed. Experimental results check very well with theoretical expectations.

### 20.3. Television Field Intensity Measurements—A Tool in Transmitting Antenna Planning

R. E. ROHRER AND OSCAR REED, JR.,  
*Jansky and Bailey, Inc.,  
Washington, D. C.*

Extensive experience with field intensity measurements is useful in the planning for television transmitting antenna systems, and station transmitter plant location. Measurements made on stations over various types of terrain show a marked difference in the slope of the curves depicting the ratios of decile to median values. The results show some correlation with transmitting antenna height and power gain. The importance of providing for relatively uniform signal level over urban areas is illustrated. Field intensity measurements can also be used to determine areas in need of booster and satellite transmitting stations. A discussion of the validity of height-gain assumptions depending upon the terrain over which measurements are made is also contained.

### 20.4 A New Monitor for Television Transmitters

C. A. CADY, *General Radio  
Co., Cambridge, Mass.*

This paper will describe the development of a complex monitor intended to provide the means for testing and measuring several characteristics of modern transmitters. The advent of color television has made it desirable to review the monitoring techniques employed to date for monochrome television, and to introduce new methods of measurement. For example, the measurement of incidental fm noise on the visual transmitter, in the presence of normal video (AM) modulation.

In evolving such an instrument, many new concepts were introduced as a result of investigations in diverse fields. Studies in crystal oscillator stability were made to obtain an inexpensive and reliable oscillator with long-term stability of 5 parts in  $10^{-7}$ . The precise temperature control required led to the development of a small enclosure maintaining constant temperature within a few hundredths of a degree, yet it does not require elaborate control circuits.

The instrument must operate over a wide range in input frequencies, from 50 to 900 mc, and lead to investigations in the field of low-noise frequency multipliers employing both tubes and crystal diodes. New type discriminators have been involved to solve the problems of linearity and sensitivity for modulation detection and for sensitivity and stability for metering purposes.

The entire device has been assembled into a package of new and novel design intended to provide high heat dissipation in a relatively small volume without forced-air cooling and to provide maximum access to all parts.

### 20.5. A Pack-Type Television System

W. B. HARRIS, *R.C.A. Defense  
Electronic Products, Camden,  
N. J.*

A pack-type, battery powered, self-contained television pickup and transmitting system, suitable for man-carried operation, is described. Its high mobility and small size permit use in places not accessible to conventional video equipment. A 525 line, 30 frame interlaced picture is produced and transmitted over a one-half mile range. The hand-carried camera which employs a vidicon pickup tube includes a miniature kinescope viewfinder enabling the camera man to continuously monitor system operations.

The portable equipments comprising the Base Station are described. Here the signals from the pack set are processed to provide standard RETMA monochrome composite video output suitable for network use.

## SESSION XXI\*

TUES. 2:30-5:00 P.M.

### WALDORF-ASTORIA SERT ROOM

#### High Quality Sound Reproduction

Chairman: DANIEL W. MARTIN,  
*The Baldwin Piano Co.,  
Cincinnati, Ohio*

### 21.1. Equalization Considerations in the Design of High Quality Tape Recorders

R. H. SNYDER, *Ampex Corp.,  
Redwood City, Calif.*

\* Sponsored by the Professional Group on Audio. To be published in Part 7 of the IRE Convention Record.

Equalization for the purpose of achieving flat over-all frequency response and maximum usable signal-to-noise ratio is a major requirement. The parameters surrounding the electronic and magnetic components of the recorder are considered in relation to those which describe the information to be recorded.

### 21.2. Design of a High Fidelity 10-Watt Transistor Audio Amplifier

R. P. CROW AND R. D. MOHLER,  
*Motorola, Inc., Chicago, Ill.*

There are a number of possible designs for a high power push-pull class B transistor amplifier, however, most of these require close matching of the two output transistors for good performance. This fact represents a serious handicap both in terms of the required initial selection and the degradation of performance that occurs with unbalance resulting from transistor aging.

It has been found that the common collector configuration has many advantages over the other configurations in the design of low distortion, stable high power amplifiers that are not critical of transistor matching. Such a circuit is incorporated in a 10-watt amplifier that will be fully described. It has a low standby drain with performance suitable for high fidelity sound reproduction with a total harmonic distortion of about 1 per cent.

### 21.3. Performance of the "Distributed Port" Loudspeaker Enclosure

A. F. PETRIE, *General Electric  
Co., Syracuse, N. Y.*

There is a short discussion of the requirements of a loudspeaker enclosure followed by a description of the "infinite wall" type of baffle. The performance of a typical loudspeaker in the "distributed port" type of enclosure is then compared to the performance of this loudspeaker in the "infinite wall" type of baffle. The shortcomings as well as the advantages of the "distributed port" type of enclosure are explained. A short demonstration of the low frequency response and power handling ability of a ten cubic foot "distributed port" enclosure is given.

### 21.4. A Phonograph System for the Automobile

P. C. GOLDMARK, *CBS Labs.,  
New York, N. Y.*

The CBS Laboratories have developed a phonograph system for the automobile which, with the cooperation of the Chrysler Corporation, was fitted into all of their 1956 cars (Dodge, Plymouth, DeSoto, Chrysler, and Imperial). The paper given will deal with alternate methods, the advantages and disadvantages, and spell out some of the basic requirements which have to be met by such a system. The new 7 inch record has been developed as part of this new technique. It will play up to 45 minutes of music on side or up to one hour of speech per side. This record turns at 16 $\frac{2}{3}$  rpm and its performance characteristics will be discussed and analytically compared with the current LP records.



Specific mechanical design considerations which had to be met in the automobile will be presented, and a demonstration and slides will illustrate the actual performance of this system

## SESSION XXII\*

TUES. 2:30-5:00 P.M.

### KINGSBRIDGE ARMORY MARCONI HALL

#### Telemetry Components

Chairman: JEROME J. DOVER,  
*Edwards AF Base, Calif.*

#### 22.1. Calibration Errors in Wire Strain Gage Transducer Systems

WILLIAM HARRISON, *Allegany  
Instrument Co., Cumber-  
land, Md.*

This paper will discuss errors in electrical calibration of wire strain transducer system and recommend calibration technique to reduce the errors to a minimum. The nine simultaneous equations with fourteen variables necessary for a complete solution are included. A computer is described which reduces computation time from eighty hours to five minutes. Cases are cited where the calibration errors may be as high as eight per cent. Errors are due mostly to long transmission lines, modulus correcting resistors, and balancing network.

#### 22.2. Precision Subcarrier Discriminator for FM Telemetry

W. H. DUERIG, *Electro-Mechanical  
Research Inc., Ridgefield,  
Conn.*

The extended application of the fm/fm telemetry system has greatly increased the performance requirements of the system and hence of the individual components. The major factor at the receiving end of the fm/fm system in providing over-all system performance of the order of 1 per cent is the subcarrier discriminator. This unit with its associated band-pass and low-pass output filters must be extremely stable and linear, as well as noise free, if the system requirements are to be met. Further, its phase response to the intelligence frequencies must also be linear in order that it be free of distortion. Its output should be capable of driving a variety of recorders and also working into components.

Since the fm subcarriers are often recorded on a tape machine, the subcarrier discriminator must be capable of providing a means for compensating the tape speed error introduced as a

frequency modulation on the subcarriers. This application to tape speed error compensation, as well as use with computers, places the stringent requirement on the subcarrier system that the intelligence time delay be a constant independent of the position of the subcarrier frequency within a band, as well as permitting intelligence from a particular subcarrier discriminator to be adjusted to the same phase or time delay as the intelligence from other discriminators. Since tape recorders also introduce a considerable amount of amplitude variations on the subcarrier signals, the limiter of the discriminator must be capable of completely rejecting amplitude modulations of the order of 10 db.

A precision discriminator will be described that takes into account each of the above points in its design.

Its performance permits realization of the full dynamic capabilities of the fm telemetry system. With this unit the fm/fm telemetry system can be considered therefore to be a precise tool for the simultaneous measurement of a considerable number of physical phenomena.

In addition to the circuit description of the precision subcarrier discriminator, the requirements for its use with magnetic tape speed error compensation and with computers will be discussed.

#### 22.3. Automatic Tracking Antenna Array for the 217 MC Telemetry Band (APOTA)

H. G. OLTMAN, JR., AND B. J.  
BITTNER, *Sandia Corp.,  
Albuquerque, N. Mex.*

The receiving antenna array utilizes seven helical antennas mounted symmetrically on the center and vertices of a hexagon inscribed on a circular ground plane. The conical beam has a half power width of 20° and is circularly polarized. The linear polarized measured side lobes indicate they are greater than 17 db below the maximum gain of 20 db. Scanning action is obtained by varying the length of the lines feeding the perimeter helices. This is done in a motor driven device. The conically scanning beam thus generated rotates once per revolution of the phase shifter at a synchronous rate of 30 revolutions per second. The "cross over" null is adjusted for 86 per cent of maximum. Initial design was accomplished on a quarter scale model with particular attention given to special designs to reduce side lobe levels and control the mutual coupling effects on the beam. The sensitivity of the system has been proven suitable for tracking solar noise in the band from 200 to 240 mc.

A movie of the unit in operation is available.

#### 22.4. Subminiature Telemetry Transmitter

L. R. HENDERSHOT, *ACF  
Electronics, Alexandria, Va.*

A four channel subminiature transmitter which can be used as a telemetry unit in a guided missile or as a remote control device is described. It consists of a vhf vacuum tube oscillator, and four transistorized audio oscillators. The vhf oscillator is designed so that rf energy is generated only when the grid is modu-

lated by one or more of the audio signals, and then only during the peak portion of one half of the modulating cycle. Therefore the radiated energy is pulsating. This design feature means the entire unit requires a very small amount of power input to realize a fair amount of rf peak power output.

The circuitry of the transmitter has been designed to use a minimum number of components without sacrificing stability and reliability. All components and hardware of the unit are mounted on a small printed circuit base plate that measures approximately 2 inches by 4 inches. A container having a volume of less than 10 cubic inches is needed to house the transmitter and power pack. The design features mentioned make this unit a rugged, low cost, mass production item, and therefore ideally suited for guided missile use. Potential applications and a possible receiving system are also discussed.

#### 22.5. A Bi-Directional Pulse Totalizer for Control and Telemetry

H. D. WRIGHT, *Anatran  
Engineering Corp.,  
Pasadena, Calif.*

The instrument and associated circuitry described provides an advanced technique for the designers of computer, telemetry, and machine control systems and offers the advantages of circuit simplicity and high reliability with both visual and electrical outputs.

A pulse actuated, electrified, totalizing counter has been designed by using the design principles of the mechanical type of counter with coaxial number wheels coupled together by intermittent transfer gears, except that ten contact positions are located opposite each wheel so that discreet electrical contacts are made for each indicated number. The totalizing counter is actuated by a pulse driven bi-directional special design of stepper motor which indicates the algebraic sum of the negative and positive pulses. Predetermining action is accomplished when the preset number, established by 5 decades of coincident position switches, is reached and a relay is actuated for control functions. When the predetermined count is reached the pulse direction of the step motor is also reversed and pulses drive the counter in the negative direction until "0" is reached, which signals the beginning of a new predetermining control cycle and again reverses the counter totalizing direction.

Two succeeding predetermined control numbers may be separated from each other by using a sinusoidal signal supply and rectifying the negative and positive half of the input signals for selection of the proper switch coincidence and control action by the use of the diode logic described in detail in this paper.

The bi-directional incremental stepping motor and the totalizing mechanical counter with discreet contacts for each visually indicated number is of particular interest to the designers of automatic machines for preset control actions and for computer pulse totalization with contacts available for printers and recorders. Telemetry by wire lines or by radio link is made by placing voltage dividing resistors across the contacts of each wheel in order to provide discreet step type voltages proportional to the numbers totalized and indicated. The instrument and circuitry described is unique as a tool for the computer and control designer who wants to simplify the system design and increase reliability.

\* Sponsored by the Professional Group on Telemetry and Remote Control. To be published in Part 1 of the IRE Convention Record.

## SESSION XXIII\*

TUES. 2:30-5:00 P.M.

KINGSBRIDGE ARMORY  
FARADAY HALL

## Electron Tubes

Chairman: GEORGE D. O'NEILL,  
*Sylvania Electric Products, Inc.,  
Bayside, N. Y.*

23.1. Image Orthicon for Pickup  
at Low Light Levels

A. A. ROTOW, *Radio Corporation  
of America, Lancaster, Pa.*

This paper describes a new image orthicon developed by RCA to extend the range of useful sensitivity to extremely low light levels. The new design substantially reduces the time lag and noise level at low light levels. The primary difference between the new tube and the standard image orthicon is an increased spacing between the glass target and the mesh screen. Theoretical considerations involved in the design of the new tube are explained. The tube is described, and its characteristics and examples of its application are discussed.

23.2. Heat-Flow Considerations  
in the Design of High-  
Dissipation Receiving  
Tubes

O. H. SCHADE, JR., *Radio  
Corporation of America,  
Harrison, N. J.*

This paper discusses considerations in the design of high-dissipation receiving tubes for keeping grid temperature low. The cathode radiation intercepted by the grid is analyzed, and means of removing heat from the grid structure are discussed. The advantages of using stem heat-flow characteristics are described, as well as how these characteristics may be obtained.

An approximate series of simple calculations for the determination of grid temperature distribution is presented. The application of these design considerations to a tube such as the RCA-6CB5 horizontal-deflection amplifier designed for color tv sets is described.

23.3. The Hy-Tramp, a Grid  
Controlled High Trans-  
conductance Electron  
Multiplier

W. E. HOSTETLER, *National  
Union Electric Corp.,  
Orange, N. J.*

The Hy-Tramp is a grid controlled electrostatic electron multiplier designed to operate as a pulse amplifier with peak currents of 200 milliamperes and an overall transconductance of 100,000 micromhos. Pulse widths of several millimicroseconds and operating duty cycles

\* Sponsored by the Professional Group on Electron Devices. To be published in Part 3 of the IRE Convention Record.

of 50 per cent are feasible. Typical design limitations, such as current densities, dynode power dissipation and space charge conditions, are discussed. The utilization of additional enhance elements in the multiplier section increases the peak output currents beyond those possible with previous similar devices. Applications as pulse generators, high speed switching, coincidence and counting devices should be forthcoming.

23.4. A Long-Life Cathode for  
High-Power UHF Transmit-  
ting Tubes

M. J. SLIVKA AND R. E. MAN-  
FREDI, *General Electric Co.,  
Schenectady, N. Y.*

Factors which influence cathode life under high power, uhf conditions are discussed. These include chemical and physical effects on the cathode occurring under various modes of tube operation and cathode loading conditions. Results obtained with several types of cathodes investigated for the purpose of lengthening cathode life are presented. A description is given of a cathode that was developed which has substantially longer, dependable life than those heretofore used. Included are structural features, special processing methods and life-emission characteristics observed in two uhf transmitting tube types. In addition a description is given of an over-all grid-cathode system compatible with the improved cathode.

23.5. A Method of Measuring  
Cathode Interface  
Impedance

W. U. SHIPLEY, *General Electric  
Co., Owensboro, Ky.*

This paper includes a brief discussion of cathode interface, and a description of a method of measuring cathode interface impedance. The theory of the measurement and circuit details are covered. The method is rapid and accurate, and measures interface impedance in accordance with ASTM specification F300-55T.

## SESSION XXIV\*

TUES. 8:00-10:30 P.M.

WALDORF-ASTORIA  
STARLIGHT ROOFSymposium: The U.S. Earth  
Satellite Program—Vanguard  
of Outer Space

Chairman: W. R. G. BAKER,  
*General Electric Co.,  
Syracuse, N. Y.*

The prospect of man-made Earth Satellites to be launched in the International Geophysical Year (1957-8) has excited the imagination of engineer, scientist and layman. The launching,

\* Sponsored jointly by the Professional Groups on Antennas and Propagation, Telemetry and Remote Control, and Military Electronics. To be Published in Part 1 of the IRE Convention Record.

placing in orbit, construction of the rockets and satellite itself present interesting engineering challenges. Few realize, however, the scope of the problems associated with the communication and collection of data from such a missile.

The objectives of the satellite program and the scientific gains to be achieved will be covered in this discussion. The major emphasis, however, will be placed upon problems of:

1) Keeping track of the missile which is to be done by radio and, more precisely, by optics, and

2) Gathering data from the missile. All of this involves radio transmission, propagation and intermittent reception at many points widely separated along the ground, and rapid computations based on such data.

The establishment of a satellite might conceivably be accomplished without the use of the electronic art. The use of electronics, however, will increase immeasurably its value to man.

## 24.1. The IGY Program

JOSEPH KAPLAN, *National  
Academy of Sciences,  
Washington, D. C.*

24.2. The Exploration of Outer  
Space with an Earth Satellite

J. P. HAGEN, *Naval Research  
Laboratory, Washington, D. C.*

24.3. Placing the Earth Satellite  
in its Orbit

M. W. ROSEN, *Naval Research  
Laboratory, Washington, D. C.*

24.4. Telemetry and Propagation  
Problems of Placing the Earth  
Satellite in its Orbit

D. G. MAZUR, *Naval Research  
Laboratory, Washington, D. C.*

24.5. Tracking the Earth Satellite  
and Data Transmission by Radio

J. T. MENGEL, *Naval Research  
Laboratory, Washington, D. C.*

24.6. Optical Instrumentation of  
the Earth Satellite

F. L. WHIPPLE, *Harvard University,  
Cambridge, Mass.*

24.7. The Scientific Value of  
the Earth Satellite Program

J. A. VAN ALLEN, *State Uni-  
versity of Iowa, Iowa City,  
Iowa*

## SESSION XXV\*

TUES. 8:00-10:30 P.M.

KINGSBRIDGE ARMORY  
MARCONI HALLColor Television Tape  
Recording

Chairman: W. W. WETZEL,  
Minnesota Mining & Manu-  
facturing Co., Saint Paul,  
Minn.

25.1. A Magnetic Tape System for  
Recording and Reproducing  
Standard FCC Color  
Television Signals—  
General Considerations

H. F. OLSON, *RCA Laboratories,  
Princeton, N. J.*

A system for recording and reproducing television signals by means of magnetic tape was described and demonstrated more than two years ago. Since that time further developments have been made as follows: a reduction in tape speed from 30 to 20 feet per second. An increase in resolution by the use of improved heads and the addition of a fifth channel for carrying the combined highs. Recording and reproducing a complete composite FCC color signal. An improved servo system for maintaining constant equivalent tape speed in recording and reproducing the television signal.

25.2. A Magnetic Tape System  
for Recording and Reproducing  
Standard FCC Color  
Television Signals—  
Electronic System

W. D. HOUGHTON, *RCA Lab-  
oratories, Princeton, N. J.*

The most important consideration in the selection of a system for producing FCC color signals, from information stored on magnetic tape, was the phase stability of the color carrier and burst components. In order to insure the desired stability in a practical field test system, the color carrier is not recorded on the tape. Instead, the composite color signal is decoded into its simultaneous color components. These signals are then recorded on separate tracks on the tape. In reproduction, the simultaneous signals are applied to a different color carrier by standard encoding equipment.

25.3. A Magnetic Tape System for  
Recording and Reproducing  
Standard FCC Color Tele-  
vision Signals—The  
Magnetic Head

J. A. ZENEL, *RCA Laboratories,  
Princeton, N. J.*

\* Sponsored jointly by the Professional Groups on Audio and on Broadcast Transmission Systems. To be published in Part 7 of the IRE Convention Record.

A magnetic head, capable of recording and reproducing a complete video signal, or any similar wide band of frequencies, has been developed by the RCA Laboratories. The head is capable of resolving wavelengths considerably smaller, and at a rate considerably faster, than that which had been possible in previous magnetic recording practice. The basic unit has been incorporated in a multichannel head which has proven itself in three years of experimental video recording. RCA Laboratories heads were used by the RCA video tape recorder in the public demonstrations of December, 1953, and May, 1955. Mechanical and electrical problems concerning the basic unit, as well as those posed by the demands of the recording system, are discussed.

25.4. A Magnetic Tape System for  
Recording and Reproducing  
Standard FCC Color Tele-  
vision Signals—The Tape  
Transport Mechanism

A. R. MORGAN AND M. ARTZT,  
*RCA Laboratories,  
Princeton, N. J.*

The problem of providing a tape transport mechanism for recording and reproducing video signals might be specified by a statement to the effect that the reproduced picture on a kine-scope must not have more "jitter" than one or two picture elements.

The approach to meeting such a specification has been the use of two servomechanisms in tandem. The first is a servomechanism controlling the motion of the capstan so as to minimize the irregularities of recording and reproducing of the video signal. The second servomechanism controls the motion of a movable reproducing head so as to reduce further the irregularities remaining from capstan operation.

Considerable attention must be given to such details as tape tension and guiding, minute adjustment of all aspects of head alignment, reel configuration, starting and stopping of the tape, and perhaps most important of all the precision of mechanical design and shop work.

In the present system it has been established that commercially "jitter" free pictures can be reproduced with a tape speed of 20 feet per second. Reels with a diameter of 20 inches can give a playing time, per reel, of 15 minutes. Starting time with a full reel of tape is the order of 5 to 7 seconds.

The capstan synchronizing system will be most effective when the tape loading is constant. This effect is obtained if the tape tension is maintained at a fixed value. Two separate servo systems are required to accomplish this, one controlling the braking applied to the supply reel and one controlling torque on the take-up reel drive. Two methods of obtaining constant tension in both supply and take-up reels have been developed and are described. Both are apparently satisfactory in operation; choice between them largely depends on practical rather than theoretical considerations.

25.5. A Magnetic Tape System for  
Recording and Reproducing  
Standard FCC Color Tele-  
vision Signals—Audio  
Systems

J. G. WOODWARD, *RCA Lab-  
oratories, Princeton, N. J.*

Because of certain requirements of the video portions of the television tape-recording

system, conventional audio-recording methods are not satisfactory, and the audio program signals are recorded by means of a modulated carrier. Both amplitude- and frequency-modulated carriers have been used. Tape noise and distortion are serious limitations in a simple AM carrier system. A two-carrier AM system provides a degree of noise reduction, but here too, the tape is the limiting element. With a wide-deviation fm system the tape does not contribute significantly to noise and distortion, and tape speed constancy in the television recorder permits an adequate signal-to-noise ratio.

## SESSION XXVI\*

WED. 10:00 A.M.-12:30 P.M.

BELMONT PLAZA  
MODERNE ROOM

## Microwaves 1—General

Chairman: W. A. EDSON,  
*Stanford University,  
Stanford, Calif.*

26.1. Leakage Radiation from a  
Braided Co-Axial Cable

E. R. SCHATZ, M. E. TAYLOR,  
R. F. ROBL, AND K. L. KON-  
NERTH, *Carnegie Institute of  
Technology, Pittsburgh, Pa.*

Criteria for the evaluation of the shielding effectiveness of coaxial cables with braided outer conductors are established and discussed. Experimental tests disclose the presence of five of the six possible field components outside the cable and show that deliberate changes in the braid configuration (twisting, damaging, etc.) cause significant changes in the field patterns, but particularly in those field components caused by localized braid dissymmetries. The latter components are attenuated rapidly with radial distance from the cable. Experimental results in conjunction with a theoretical study of solid outer-conductor coaxial cables lead to a definition of shielding effectiveness.

26.2. A Trimode Turnstile  
Waveguide Junction

R. S. POTTER, *Naval Research  
Lab., Washington, D. C.*

The microwave junction studied in this paper is a seven port variation of turnstile waveguide junction with a coaxial port opposite and centered on the axis of the circular waveguide. Assuming only  $TE_{10}$ ,  $TE_{11}$  and TEM modes being propagated respectively in the rectangular, circular, and coaxial waveguide; the junction's scattering matrix, the normal modes, the normal mode scattering coefficients, and the relations between the elements of the scattering matrix and the normal mode scattering coefficients are determined. These quantities reveal that the junction possesses many unique properties of its own as well as a number of properties also found in the ordinary turnstile waveguide junction.

\* Sponsored by the Professional Group on Microwave Theory and Techniques. To be published in Part 5 of the IRE Convention Record.

### 26.3. The H-Guide, a Waveguide for Microwaves

F. J. TISCHER, *Huntsville, Ala.*

The waveguide described in the paper has the cross section of an *H* and consists of two parallel conducting strips with a dielectric slab between them. The dielectric slab concentrates the energy transport of waves originated by an *E*-plane horn with the *E*-vector parallel to the conducting strips in the center region of the guide, and only a small fraction of the energy is transported outside the guide. The cross sectional distribution of the density of the energy flow can be, with certain limitations, arbitrarily chosen by proper dimensions of the guide. Calculation shows attenuation of *H* guide is low and decreases with increasing frequency. The guide seems useful for low-loss transmission and for simple fabrication processes of complicated microwave circuitry.

### 26.4. Microwave Spectrum Synthesis Using the Traveling-Wave Tube

P. D. LACY, *Hewlett-Packard Co., Palo Alto, Calif.*

The most common microwave spectra are obtained from keyed or frequency modulated oscillators, however, there is now an increasing use of the MOPA type of system having the inherent advantages of frequency stability and phase coherence. The broad bandwidth and the amplitude and phase modulation capabilities of the TWT amplifier allow a versatile approach to microwave spectrum synthesis in such systems. Passive modulators are also increasing in importance for such applications, however, the present devices are more limited in performance.

Examples of a variety of individual signals with spectral distributions that can be generated by the TWT will be given. Also many radar and navigational systems utilize two slightly different spectra corresponding to a direct and reflected transmitter signal. The TWT is well suited to provide slight spectral displacements necessary to generate multiple microwave test signals that often have never been encountered except in field tests.

A tabulation of useful microwave spectra and how they may be generated by the TWT for test purposes will be presented.

### 26.5. An Orthogonal Mode Transducer

R. L. FOGEL, *Hughes Aircraft Co., Culver City, Calif.*

The problem of launching or separating two physically orthogonal modes in multimode transmission systems can be solved by using orthogonal mode transducers. The design of such transducers which are required to meet broad band and high power specifications, as well as some practical applications of these devices are discussed. One of the approaches to this problem has led to the development of an orthogonal mode transducer which has a  $v_{swr}$  of less than 1.15 over a 10 per cent frequency band at X band, will handle 250 kw peak power and has a cross coupling ratio of 35 db. Development work is continuing on at least two more orthogonal mode transducers of different configurations which are mechanically simpler and are expected to have improved cross coupling characteristics.

## SESSION XXVII\*

WED. 10:00 A.M.—12:30 P.M.

### WALDORF-ASTORIA STARLIGHT ROOF

#### Engineering Management Techniques

Chairman: CHARLES N. KIMBALL,  
*Midwest Research Inst.,  
Kansas City, Mo.*

#### 27.1. Words Needn't Fail

P. R. BEALL, *Management Consultant, Annapolis, Md.*

Industrial and commercial companies of all sizes and in every business have frequent occasions when it would be profitable for them to make informative briefing presentations to their customers or to their owners or workers.

Modern men of industry and science are engaged in forming exact ideas and expressing them in objects made of plastics and steel and in electronic devices—in everything but language. Never before in history have smart men been so dumb—meaning mute. Yet in commerce as well as in government and world affairs it is still appropriate to quote Salisbury, English statesman of the nineteenth century who said, "In these days whether we like it or not, power is with the tongue, power is with him who can speak."

Miraculous channels for speech (teletype, television, the cinema, etc.) are in use. Yet channels as such contribute little to the clear expression of exact ideas. "Power is with the tongue" does not mean "Power is with the microphone or automatic mutilith machine."

The author will explain how any company, using their own personnel for speakers, can successfully articulate and communicate its message to any audience it is able to assemble.

#### 27.2. How Teamwork Brainstorming Solves Problems

W. A. PLEUTHNER, *Batten, Barton, Durstine, and Osborn, Inc.,  
New York, N. Y.*

Alex F. Osborn, the "O" of BBDO started brainstorming 17 years ago. The author was one of his pioneer brainstormers and for the past two years has been and is now in charge of brainstorming for all 14 offices of BBDO. He has organized and participated in literally hundreds of brainstorm sessions, working on a wide variety of problems.

During the past year he has worked with large companies in organizing brainstorming within their own organizations. These well known and successful firms include: General Electric Company, Corning Glass, Armstrong Cork Co., Bristol-Myers, U. S. Steel and New York Telephone.

This paper will cover the following major subjects in detail. How to organize Brainstorm Panels; coining a simple, specific problem; rules and procedures at meetings; screening and follow-up of resulting ideas; why this group

method of problem solving develops more ideas than sole ideation on the same problem; how to get started.

### 27.3. Strengthening the Recognition of Engineering

G. W. GRIFFIN, JR., *Sylvania Electric Products, Inc.,  
New York, N. Y.*

Recognition for any profession does not come automatically; it must be earned. Achievement is not enough; *recognition* of achievement is second in importance only to achievement itself. This does not mean propagandizing in its derogatory sense; it means communicating with the other professions, with industry, with the economy as a whole—and, equally important, with other engineers. There is a great difference between engineers as individuals and engineering as a profession. The individuals may have recognition, but the over-riding consideration is assuring that the profession has the acceptance and resultant support which it so definitely deserves.

### 27.4. The Motivation of Technical People

L. M. SPENCER, *Science Research Associates, Chicago, Ill.*

Four requirements for the successful management of engineers are: 1) selecting capable, imaginative and technically competent people; 2) creating a work climate which facilitates the production of creative ideas; 3) a clear specification of management's expectations of its technical staff; and 4) an understanding on the part of management of the expectations of the technical specialist. Mr. Spencer will discuss these factors as they influence the motivation and the performance of the technical specialist in modern industry. In addition he will deal with the way in which an understanding of these factors can bring about a more productive working relationship between the technical and administrative branches of an organization.

## SESSION XXVIII\*

WED. 10:00 A.M.—12:30 P.M.

### WALDORF-ASTORIA ASTOR GALLERY

#### Flight Data Reduction Systems

Chairman: HOMER R. DENIUS,  
*Radiation, Inc., Melbourne,  
Fla.*

#### 28.1. An Improved System for Collecting and Processing Flight Test Data

H. W. ROYCE, *Glenn L. Martin  
Co., Baltimore, Md.*

\* Sponsored by the Professional Group on Engineering Management. To be published in Part 6 of the IRE Convention Record.

\* Sponsored by the Professional Group on Telemetry and Remote Control. To be published in Part 1 of the IRE Convention Record.

This report outlines a system which will be capable of collecting aircraft and missile flight test data and of resolving data reduction problems presently encountered. At the same time this system offers a method for preserving better accuracy and permitting some simplification in adding new measurements found to be necessary late in the program.

Reasons are presented for the use of digital recording on magnetic tape as replacement for the photo panel and brown recorder and also the use of magnetic tape for recording of high frequency information in fm form to replace the oscillographs now being used. Both systems will allow the use of automatic techniques for processing the data, since the information is recorded in electrically retrievable forms. The low frequency system has better accuracy than present systems and for most cases the high frequency system has the equivalent or better accuracy.

## 28.2. Airborne Data Acquisition System

W. H. FOSTER, *Electronic Engineering Co., Los Angeles, Calif.*

The contents of this paper are comprised of the results of Phase II of Project DATUM, awarded by EAFB to EECo of Calif. DATUM is the code name for Data Acquisition and Transmission by Uniform Methods. Phase II is the airborne data acquisition portion of the project. It consists of both accumulating and recording flight data.

In addition to the entire system itself, several new units discussed in the paper are: the airborne magnetic tape recorder, recently developed strain gage oscillators, the calibration system, and possibly a new transducer to record total fuel used.

This new approach to the accumulation of airborne data by uniform means facilitates rapid, sometimes "instantaneous" data reduction. In addition, there exist no problems of time and event correlation, such as existed when some data was recorded on photo panel, some on oscillograph recording, and some on magnetic tape after air to gnd telemetering. With this relatively new system accuracies of 10 per cent are "readily" obtainable.

Preliminary checkout of the system, under simulated conditions, indicates that all design goals have been met, some superceded. Complete flight tests will be completed in December.

## 28.3. Requirements of a High Speed, High Quantity, All-Electronic Data Processing System

F. K. WILLIAMS, *Rocketdyne Field Lab., Rocketdyne, Canoga Park, Calif.*

Handling large quantities of data taken over relatively wide bandwidths is customarily done by hand or electromechanical semi-automatic systems. To circumvent the problem of handling this data, Rocketdyne has developed an all electronic, high speed high quantity data system. This system operates on a total bandwidth of 1,500 cps (based on Hartley's criterion) or 10 thousand conversions/second of nine bits each. Analog information is received from one hundred separate input channels, multiplexed,

clamped and converted. This data is recorded in a permanent storage on magnetic tape capable of holding eight minutes of information or four million eight hundred thousand, eighteen bit words. Each word contains the information produced from a channel and the identification of the channel plus a gross error marker. Since all of the data is recorded in digital form on tape, it can be used to supply information to a digital electronic computer, in this case an IBM 701 or IBM 704. The taped raw data is played back into a data selector circuit which eliminates all unwanted data timewise. Finally, the data is transcribed onto two IBM 727 tape units in blocks of arbitrary length. This blocked data can then be processed directly from the console of the IBM computer in any way desired. Analog records can be reproduced, computing can be done, or punched card or typed data taken from the machines output. The latter part of the system can also be fed from a digital radio telemetering system.

## 28.4. Techniques for a High Speed, High Quantity All-electronic Data Processing System, IDIOT II

M. L. KLEIN, *Rocketdyne Field Lab., Rocketdyne, Canoga Park, Calif.*

The design of a high speed, all-electronic data handling system requires the use of several novel techniques. Multiplexing is accomplished with an electro-mechanical, mercury jet switch which simultaneously acts as a keying system for the whole record. Each input is slamped in an all-electronic system which allows a finite period for the conversion to binary code. The convertor, a programmed trial voltage encoder which successively tries binary voltages and executes a fixed logic, yields a straight binary code output. This output, along with the channel identification and error marker are transcribed onto tape in blocks of six and timing markers added. This tape record is the permanent data storage. To feed the data into a computer, the data is first played into a time filter which examines only wanted data. Each block of six bits is examined for oddness and evenness and a parity check mark added to maintain oddness of bits. Finally this data is recorded on two IBM 727 tape units, blocked out into pre-set lengths with ten millisecond gaps inserted without loss of data. This technique makes use of the displaced time head method for keying. With the data available in this form, it can be used by the IBM 701 or 704 computer from console control.

Several million words of data can be handled automatically in this manner and processed at extremely high speeds.

## SESSION XXIX\*

WED. 10:00 A.M.-12:30 P.M.

WALDORF-ASTORIA  
JADE ROOM

Broadcast and Television  
Receivers

\* Sponsored by the Professional Group on Broadcast and Television Receivers. To be published in Part 3 of the IRE Convention Record.

Chairman: LYMAN R. FINK,  
*General Electric Co.,  
Schenectady, N. Y.*

## 29.1. Application of Transistors to Battery-Powered Portable Receivers

J. W. ENGLUND, *Radio Corporation of America, Harrison, N. J.*

This paper presents design considerations for the application of alloy-junction *p-n-p* transistors to broadcast portable receivers. Optimum operating conditions are given for both mixer-oscillator and converter input stages as regards signal-to-noise ratio and conversion transconductance.

Various intermediate-frequency amplifier circuits are discussed, including (a) base input, common emitter, (b) unilateralized, (c) emitter input, common base, and (d) split input. Considerations for design of networks for unilateralization at the optimum operating point are given. Problems involved in the application of automatic gain control to the IF amplifiers are also discussed. The various IF-amplifier circuits are evaluated for changes in input and output impedance, unilateralization, gain, and selectivity with operating point and with temperature.

The relative merits of transistors and diodes in a second detector circuit are evaluated.

An audio system using a typical driver and class B push-pull arrangement is briefly described. The over-all performance of a receiver using *p-n-p* alloy-junction transistors is evaluated as to sensitivity, selectivity, and stability with temperature.

## 29.2. Stability Considerations in Transistor IF Amplifiers

D. D. HOLMES AND T. O. STANLEY,  
*RCA Labs., Princeton, N. J.*

Transistors which are capable of providing 30 to 40 db gain at 455 kc have become relatively commonplace; the development of such units has led to the need for a better understanding of the factors which determine the stability of transistor IF amplifiers. An understanding of these factors permits intelligent amplifier design, and facilitates comparison of various transistor types in terms of maximum usable gain.

This paper presents procedures for the design of single- and double-tuned interstages to be employed in tuned transistor amplifiers; these procedures are based on stability considerations. Examples of single- and double-tuned interstage designs are included, and the design considerations for amplifiers having many or different stages are outlined.

## 29.3. Analysis of Double Tuned Transformers for Transistor Amplifiers

J. HELLSTROM, *Westinghouse Electric Corp., Metuchen, N. J.*

In transistor broadband amplifiers power gain is a prime consideration. Therefore, coupling networks should have maximum power

transfer as a design objective. The use of damping resistors to obtain bandwidth, as is the practice in vacuum tube circuits, is wasteful of power and unnecessary if unequal primary and secondary  $Q$ 's are used. Others have analyzed the double tuned transformer with unequal  $Q$ 's for the condition of maximum power transfer. In certain practical cases, however, a high device output  $Q$  makes maximum transfer impossible. There are definite values of the ratio of primary to secondary  $Q$ 's which will permit the closest approach to this maximum transfer.

This paper extends the analysis to include transformer design for the general case, with any  $Q$  ratio, in which maximum power transfer may be unattainable. Design charts are developed and examples of their application are given. Contours of constant power transfer, constant peak to valley response ratio and constant bandwidth ratios are plotted on the primary-secondary  $Q\Delta F/F_0$  plane. These charts elucidate the concepts of critical and transitional coupling. An example shows coupling coefficients between critical and transitional to be useful in a transistorized video IF amplifier stage.

#### 29.4. Transient Response vs Chrominance Bandwidth in Simultaneous Color Television Receivers

C. W. BAUGH, JR. AND H. E. SWEENEY, *Westinghouse Electric Corp., Metuchen, N. J.*

A study was made of the transient distortions arising from signal processing in a simultaneous color receiver. The pass bands through which the signals travel creates in-phase and quadrature distortion. The addition of signals of different bandwidth and addition in nonlinear devices are further causes of distortion.

To show the effect of these distortions, the instantaneous luminance and chrominance information was plotted against time for transitions between various colors.

It was generally concluded that, for an equiband receiver, chrominance passbands with 6 db points of 1,000 kc below and about 600 kc above the subcarrier frequency produces the optimum result.

#### 29.5. A Deflection and Convergence System for Use with the Color Picture

R. B. GETTMANN, *General Electric Co., Syracuse, N. Y.*

A toroidal type deflection yoke has been developed that has many desirable features that simplify the convergence and deflection in a multibeam color tube. The yoke has the mechanical simplicity of a single layer selenoid wound on a ferrite ring. Two windings have been interleaved to provide horizontal and vertical deflection. Control of raster size and trapezoidal distortions is easily achieved.

Mechanical and electrical considerations necessitate the choice of a low yoke impedance. The yoke may be efficiently operated with conventional circuits and step down transformers. It combines excellent convergence with simplicity of adjustment.

## SESSION XXX\*

WED. 10:00 A.M.—12:30 P.M.

### WALDORF-ASTORIA SERT ROOM

#### Circuits I—Symposium on Application of Recent Network Ideas to Feedback System Problems

Chairman: JOHN R. RAGAZZINI, *Columbia Univ., New York, N. Y.*

#### 30.1. Network Theory in the Practical Design of Control Systems

J. G. TRUXAL, *Polytechnic Institute of Brooklyn, Brooklyn, N. Y.*

Modern network theory interpreted to encompass synthesis techniques, approximation and measurement techniques, feedback theory, and statistical design theory—and nonlinear circuit theory—has provided the control engineer the basic analysis and design techniques for feedback control systems. Some of the recent network-theory developments which should be of increasing importance to control engineers are the study of feedback theory and multi-loop feedback systems (including conditionally stable systems) and the extensive investigation of nonlinear systems with aperiodic and random input functions.

#### 30.2. Some Studies Applicable to the Problem of Stability in Linear Systems

J. L. BOWER, *North American Aviation, Inc., Downey, Calif.*

The present theory of stability of closed-loop systems depends on the general assumption that the regularity of the Laplace transform of the closed-loop impulse response on the imaginary axis and in the right half-plane is sufficient for stability. The failure of this criterion can be demonstrated and justifies investigation into its limitations especially in view of the growing interest in systems involving unusual transfer properties.

#### 30.3. Root Locus in Feedback System Synthesis

J. A. ASELTINE, *Lear, Inc., Santa Monica, Calif.*

The root locus method is reviewed briefly, with emphasis on a logical basis for locus construction. A procedure is presented which makes possible the rapid construction of a qualitative plot in almost all cases. Synthesis by the direct root locus method is discussed and illustrated by example. Next, the modifi-

cation of the method when applied to positive feedback systems is discussed, and the inverse root locus method introduced. The inverse method is applied to the synthesis problem for feedback systems and illustrated by examples. A comparison is made between the root locus methods of feedback—system synthesis and other methods.

#### 30.4. Modulated Control Systems

R. E. GRAHAM, *Bell Telephone Labs., Inc., Murray Hill, N. J.*

Modulated control systems are defined as nonstationary closed-cycle control processes; *i.e.*, systems whose properties vary with time. These include cases with sinusoidal, square-wave, or pulse carriers, the latter type being better known as sampled systems. The conditions are reviewed under which various modulated systems can be regarded as linear, and under which the lack of stationarity is trivial. Under such conditions a wealth of linear circuit theory is available for analysis and design. Finally, the techniques for understanding and designing sampled systems are discussed for cases where the sampling rate is uncomfortably low relative to the signal frequencies.

## SESSION XXXI\*

WED. 10:00 A.M.—12:30 P.M.

### WALDORF-ASTORIA GRAND BALLROOM

#### Nuclear Effects on Electronic Systems

Chairman: EARL C. COOK, *Signal Corp. Engineering Labs., Fort Monmouth, N. J.*

#### 31.1. Effects of Nuclear Radiation on Electronic Components

THOMAS BALDWIN, *Evans Signal Lab., Belmar, N. J.*

#### 31.2. Nuclear Effects on Communication Systems

JACK EGGERT, *Signal Corps Engineering Labs., Fort Monmouth, N. J.*

#### 31.3. Dose Rate Dependence of Dosimeters at Dose Rates up to Two Million Roentgen Per Hour

MARVIN STEIN, *Evans Signal Lab., Belmar, N. J.*

\* Sponsored by the Professional Group on Circuit Theory. To be published in Part 2 of the IRE Convention Record.

\* Sponsored by the Professional Group on Military Electronics. To be published in Part 8 of the IRE Convention Record.

### 31.4. Techniques of Measurement at High Radiation Rates

PETER BROWN, *Signal Corps Engineering Labs., Fort Monmouth, N. J.*

### 31.5. Radiological Instrumentation

JERROLD CARP, *Signal Corps Engineering Labs., Fort Monmouth, N. J.*

## SESSION XXXII\*

WED. 10:00 A.M.—12:30 P.M.

KINGSBRIDGE ARMORY  
MARCONI HALL

### Electronic Computers I

*Chairman:* DAVID R. BROWN,  
*Massachusetts Institute of Tech., Cambridge, Mass.*

#### 32.1. A Multiple Input Analog Multiplier

D. D. PORTER AND A. S. ROBINSON, *Columbia University, New York, N. Y.*

This paper describes an electronic analog computing technique for obtaining the product of a number of input variables. Positive voltage analogs of the input factors are periodically sampled to produce an output product which changes in discrete steps at the sampling rate.

The multiplier consists of a simple electronic integrator, a comparator, two output storage gates, and an additional comparator for each input. A five input multiplier is described which operates at a sampling rate of 400 cps with a transition time to the new product value of 100  $\mu$ sec.

#### 32.2. Analog Multiplying Circuits Using Switching Transistors

KAN CHEN AND R. O. DECKER,  
*Westinghouse Electric Corp., East Pittsburgh, Pa.*

Analog multiplication schemes based on the principle of modulated rectangular pulses have been developed using switching transistors and square-loop magnetic cores. A two quadrant multiplying circuit employs amplitude and frequency modulation. A four quadrant multiplying circuit employs amplitude and pulse-width modulation.

Each circuit has a high degree of reproducibility and basic simplicity that is not found in most vacuum tube multipliers. The accuracy over a two decade range of output is as good as that achieved by more complex vacuum tube circuits. Good temperature stability is possible because the transistors operate in a switching mode. The response time of both multiplying circuits is equal to one cycle of the modulated

\* Sponsored by the Professional Group on Electronic Computers. To be published in Part 4 of the IRE Convention Record.

rectangular pulses. With distinct durability, dependability and long life, these circuits should find wide acceptance in both industrial and military applications.

#### 32.3. Logic Design of the RCA Bizmac Computer

A. D. BEARD, L. S. BENSKY,  
D. L. NETTLETON, AND  
G. E. POORTE, *Radio Corporation of America, Camden, N. J.*

The RCA Bizmac computer has been developed as a major element of the Bizmac system, and may be described as a general-purpose three-address stored-program machine. It has certain specialized features which make it adept in cyclical accounting applications: completely variable word length in all internal operations; highly-flexible instruction complement directed toward data-organizing ability; a control philosophy which offers great operational flexibility and simplifies troubleshooting and maintenance.

The present paper will outline the control and organizational concepts of the computer.

#### 32.4. Input and Output Devices in the RCA Bizmac System

J. A. BRUSTMAN, K. L. CHIEN,  
C. I. COLE, AND D. FLECHTNER,  
*Radio Corporation of America, Camden, N. J.*

This paper will describe the functional characteristics and some of the design features of the following equipments:

*Tapewriter*—A manual keyboard device which creates punched paper tape.

*Tapewriter-Verifier*—Permits a character-by-character verification of a previously prepared tape.

*Paper Tape Transcriber*—Transfers information from the punched paper tape to magnetic tape.

*Card Transcriber*—Translates information from punched cards to Bizmac code on magnetic tape.

*Electro-Mechanical Printer*—The major high-speed output printer of the Bizmac System.

*Magnetic Tape Transcriber*—Transfers information from magnetic tape to punched paper tape in the RCA Bizmac code.

*Interrogation Unit*—Permits direct access to the Tape File for a rush random interrogation.

#### 32.5. Burroughs Series G High Speed Printer

E. M. DIGIULIO, *Control Instrument Co., Inc., Brooklyn, N. Y.*

The Burroughs Series G high speed printer is a device capable of printing 900 lines per minute from punched cards. It represents the greatest single advance yet achieved in increasing the speed of tabulating and printing machines. This paper discusses some of the basic design features that make this high speed operation feasible. Chief among these are the dual card feed with its independent picker

knife control, the unique wire printing arrangement and the electronic circuitry used for decoding and encoding information to be printed. The paper will also cover some of the features to be incorporated in subsequent machines of this series, such as accumulation, magnetic core storage, a bill feed printer and a printer punch.

## SESSION XXXIII\*

WED. 10:00 A.M.—12:30 P.M.

KINGSBRIDGE ARMORY  
FARADAY HALL

### Antennas and Propagation—Antennas

*Chairman:* JOHN F. BYRNE,  
*Motorola, Inc., Riverside, Calif.*

#### 33.1. Cross Polarization Effects on Antenna Radiation Patterns

NATHAN MARCIAND, *Marchand Electronic Labs., Byram Conn.*  
AND W. G. SCOTT, *Melpar, Inc., Falls Church, Va.*

The radiation pattern of a linearly polarized antenna excited by a linearly polarized wave is shown to be dependent in amplitude, shape, and direction upon the relative polarization of antenna and wave. The dependence of beam direction on polarization is of primary importance in practical direction-finding problems. A function is derived based on a geometrical analysis incorporating arbitrary, polarization orientations, wave elevation angle and aperture inclination. To compute the pattern shift, the function is applied to a known theoretical pattern expression. For most orientations of antenna and wave the azimuthal pattern peak is shown to be shifted away from the antenna boresight direction. Experimental patterns are presented which show good agreement with computed ones. Also curves are given of beam shift vs the elevation angles and beamwidths of a waveguide horn polarized at 45 degrees to the vertical.

#### 33.2. A Vertical Antenna Made of Transposed Sections of Coaxial Cable

H. A. WHEELER, *Wheeler Labs., Great Neck, N. Y.*

A vertical array of colinear vertical dipoles is made of a series of sections of solid-dielectric coaxial cable with their inner and outer conductors transposed at each junction. Each section has an effective length of 1/2 wavelength in the cable, so the radiating gaps between the sections are all excited in the same polarity. A model designed for 450 mc has 9 sections of cable; the length is 2.9 wavelengths in free space and the gain is 6 db over a half-wave dipole. This type of antenna has been developed in cooperation with Communication Products Company of Marlboro, N. J.

\* Sponsored by the Professional Group on Antennas and Propagation. To be published in Part 1 of the IRE Convention Record.

### 33.3. Electrically Small Ferrite Loaded Loop Antennas

V. H. RUMSEY AND W. L. WEEKS,  
*University of Illinois  
Urbana, Ill.*

Approximate formulas have been developed for the impedance, efficiency and  $Q$  of electrically small ferrite loaded loop antennas. The formulas are based on an assumed knowledge of these parameters for the antenna without ferrite loading and on an assumed distribution of magnetic field in the ferrite. They are derived by using the reaction concept which makes the result relatively insensitive to the assumed distribution, the latter being taken as the static field. The results are used to evaluate the effect of ferrite size and shape. The results of a variety of measurements are given for comparison.

### 33.4. A Wide-Band Coaxial Hybrid

ANDREW ALFORD AND C. B. WATTS, JR., *Andrew Alford Consulting Engineers, Boston, Mass.*

A family of coaxial transmission line bridges exhibiting hybrid properties is described. These bridges differ from the conventional hybrid ring "rat-race" in that the balance is inherently independent of frequency. They can be readily impedance compensated over a one octave band.

An accurately constructed bridge for rigid coaxial transmission line has found use in the laboratory measurement of very small impedance mismatches. Reflection coefficients of the order of 0.01 in 3 1/8 inch diameter transmission line are measured with a precision of about plus or minus 0.001 in magnitude and plus or minus 5° in phase angle at 200 megacycles.

### 33.5. Dielectric Bifocal Lenses

R. M. BROWN, *Naval Research Laboratory, Washington, D. C.*

A study has been made of the scanning properties of solid dielectric bifocal lenses. In two dimensions a bifocal lens is a two-surface lens, symmetric about an axis, designed to collimate the rays from a primary point source located at either of two conjugate off-axis points into plane waves making angles  $+\alpha$  and  $-\alpha$  respectively with the axis. A point-by-point technique used in computing the lens surfaces is discussed. Three-dimensional polystyrene lenses, all 50 wavelengths in diameter and with  $\alpha=20^\circ$ , were built by rotating two-dimensional designs about their axes. The optical aberrations and the radiation patterns of four such lenses are described.

## SESSION XXXIV\*

WED. 2:30-5:00 P.M.

BELMONT PLAZA  
MODERNE ROOM

\* Sponsored by the Professional Group on Microwave Theory and Techniques. To be published in Part 5 of the IRE Convention Record.

## Microwaves II—Ferrites

Chairman: C. L. HOGAN, *Harvard Univ., Cambridge, Mass.*

### 34.1. The Design of Non-Reciprocal Phase Shift Sections

H. N. CHAIT AND N. G. SAKIOTIS,  
*Naval Research Laboratory, Washington, D. C.*

Rectangular waveguide sections, asymmetrically loaded with transversely magnetized ferrites, are used in the design of various non-reciprocal microwave devices such as circulators.

This paper discusses the manner in which the ratio of differential phase shift to power absorbed varies under a variety of operating conditions. A number of different geometrical configurations of the ferrite, waveguide, and applied field will be described along with the pertinent experimental results. A study showing the effect of varying some of the parameters, such as slab thickness and height will be described for a few typical configurations.

The results of a high power study of these differential phase shift sections will be presented with the view of determining the effect of the geometrical configuration on the non-linear propagation characteristics.

The frequency sensitivity and temperature dependence of these designs will also be discussed.

### 34.2. Tensor Permeabilities of Ferrites Below Magnetic Saturation

R. C. LECRAW AND E. G. SPENCER,  
*The Diamond Ordnance Fuze Labs., Washington, D. C.*

Cavity perturbation methods are described, using thin rods in a degenerate  $TM_{110}$  transmission cavity, for measuring the components of the intrinsic tensor permeability ( $\mu$ ) in unsaturated ferrites, in an extension of previous work. The  $TM_{110}$  microwave cavity is shown to have important advantages for rods over the usual  $TE_{11n}$  cavity. One such advantage is that the separation of magnetic from electric effects is almost complete. Using circular polarization techniques,<sup>1</sup> complete data are given up to saturation for the six components of ( $\mu$ ) as functions of internal dc magnetic field. Among interesting effects observed are negative values of  $K''$  and zero and negative values of ferrite  $Q$ . The physical implications of these observations are discussed.

### 34.3. A Miniaturized High Temperature Isolator

R. F. SULLIVAN AND R. C. LECRAW,  
*The Diamond Ordnance Fuze Labs., Washington, D. C.*

The advantages of three types of ferrite isolators (rotation, resonance, and resistance sheet) with respect to bandwidth, vswr, maximum isolation, insertion loss, temperature dependence, and miniaturization are discussed.

A miniaturized X-band single slab resistance-sheet isolator using nickel ferrite is described. The isolator is less than 1.5 in. long and weighs approximately 5/8 lb. In the

temperature range  $-50^\circ\text{C}$  to  $+150^\circ\text{C}$ , the isolation is greater than 10 db, the insertion loss less than 1 db, and the vswr less than 1.1 over a 400 megacycle band. Curves of vswr, insertion loss, and isolation as functions of frequency and temperature are presented together with a curve of bandwidth as a function of temperature.

### 34.4. Broadbanding Ferrite Microwave Isolators

P. H. VARTANIAN, J. L. MELCHOR,  
AND W. P. AYRES, *Sylvania Electric Products Inc., Mountain View, Calif.*

The bandwidth of microwave isolators using ferrites is limited by the properties of both the ferrite and the waveguide. Methods of extending this bandwidth include using ferrite properties which have a relatively small frequency dependence and using broadband types of waveguides. Isolators of the field displacement, Faraday rotation and ferromagnetic resonance types were studied. Characteristics much improved over isolators commercially available were obtained for each of the three types. The best characteristics measured to date are less than 1 db forward loss from 8 to 14.4 kmc and greater than 20 db reverse loss from 8.2 to 12.4 kmc. Similar characteristics have been obtained in S band. It is concluded that by application of the principles described, isolators with a 2 to 1 frequency range can be constructed.

### 34.5. Ferrite Microwave Phaseshifters

R. F. SOOHOO, *Cascade Research Corp., Los Gatos, Calif.*

The theory of the following two types of ferrite phase shifters will be reviewed in some detail. The development problems and experimental results of these units and their practical applications will be discussed. The two types of ferrite phaseshifters are: 1) rotational type phaseshifter based on the Faraday rotation principle, 2) transverse-field phaseshifter operating above or below ferromagnetic resonance of the ferrite.

It will be shown that the transverse-field type has the advantage of having negligible hysteresis effects and higher power handling capacity compared to the rotational type. However, the transverse-field type requires a stronger applied magnetic field than the rotational type.

### 34.6. A Balanced Stripline Isolator

O. W. FIX, *Holloman Air Force Base, N. Mex.*

The requirements of an isolator are determined to see if such a device could be constructed in balanced-stripline. A theory of isolation is conceived and two designs are developed for construction based on this theory. Both designs are constructed and the best one is exhaustively investigated. Good isolation is obtained and the proposed theory is confirmed. Isolation in excess of 16 db is obtained with the first model. An unusual effect is observed wherein different ferrite materials give isolations in reverse directions for identical fields. Suggestions are made for application of this effect and for use of the stripline isolator.



## SESSION XXXV\*

WED. 2:30-5:00—P.M.

WALDORF-ASTORIA  
STARLIGHT ROOFDesign Approaches with  
Printed WiringChairman: FREDERICK R. LACK,  
*Western Electric Co.,  
New York, N. Y.*35.1. Engineering of Printed  
Circuits to Facilitate  
ProductionR. C. CALCUT AND C. ARTZ,  
*Admiral Corp., Chicago, Ill.*

The basic reasoning for designing printed circuits for automatic production of tv sets in the form to be described will be presented. Decisions which resulted in selecting methods and procedures in these categories will be analyzed. 1) Base material and type of circuitry (*i.e.*, plated, stamped etched, single or double side, etc.); 2) circuit layout (Line widths, spacings, pads, board size); 3) component placement and termination. The basic reasoning for proceeding with production of printed circuits in each of three categories will be presented. The proper selection of the possibilities in each of the categories above as an aid in more rapid production of reliable circuit units, and how procedures which lead to the successful and ultimate goal of automation were selected and consolidated, will be covered.

35.2. Principles of Circuit Design  
for AutomationH. S. DORDICK, *Radio Corporation  
of America, Camden, N. J.*

The equivalence of circuit design requirements for high volume automation and job-shop automation is shown. A technique of analysis known as sub-modularization is described. This results in circuit elements of standard size, content, configuration, and manufacturing processing. These elements are applicable to many diverse types of equipment, creating a mass produced type of product within the job-shop. A mathematical representation is given which aids in standardization of circuits and systemizing the analysis. The technique is applied to a variety of products and the resultant standardized automation package is shown. Slides will be presented.

35.3. Modular Construction—Its  
Implications to the Design  
EngineerR. E. BAUER, *ACF Electronics  
Alexandria, Va.*

The evolution of an electronic circuit from initial design to full-scale production is traced for the case where modular construction is to be utilized. The design engineer's role in this

\* Sponsored by the Professional Group on Production Techniques. To be published in Part 6 of the IRE Convention Record.

process is outlined, with discussion of similarities and differences between design for conventional and for modular construction. Many of the procedures used in designing modules are illustrated, and pertinent points related to the physical and electrical characteristics of the module structure are summarized. One of the conclusions reached is that only a modest amount of specialized information must be assimilated before the design engineer can apply his broad background in electronic circuit design to the design of modular circuits.

35.4. A New Automation Technique  
for Soldering Components to  
Foil Wire BoardsA. A. LAWSON, P. RITT AND  
H. K. HAZEL, *Melpar Inc.,  
Falls Church, Va.*

This paper presents a new concept for the soldering of electronic components to printed wiring boards. It provides a means of controlling the time, temperature, and the amount of solder necessary to obtain a proper connection.

This soldering technique is a portion of the work being done in connection with Project Mini-Mech sponsored by the Navy Department, Bureau of Ships, and developed by engineers of Melpar, Inc.

As the component is mechanically inserted into and crimped to a typical printed wiring board, a heated anvil is brought into contact with the folded-over component lead and the printed wiring. By previously electroplating solder to the board the now present heated anvil produces a reliably soldered connection. Because of the extremely short soldering time involved (0.4 seconds) the electrical value of components is not disturbed, thus precision components can be assembled without change or damage.

This paper reports the technique for solder plating the printed wiring boards, discusses and illustrates the various methods by which the soldering technique is reduced to practical applications. It is becoming apparent that this method of soldering may well be applied to microminiature packaging of the future where the size of the soldered connection is relatively minute and where mechanization of the process is even now a necessity.

35.5. Printed Circuits via  
XerographyF. A. SCHWERTZ AND E. M. VAN  
WAGNER, *The Haloid Co.,  
Rochester, N. Y.*

A new method for placing a resist on copper-clad laminates has been developed which exploits the new technique of physical photography known as xerography. Starting with an original opaque drawing, the laminate can be prepared for etching in approximately ten minutes. Except for the final etching step, the process is completely dry and no darkroom facilities are required.

35.6. Cupric Oxidized Copper  
Foil for Printed Circuit  
LaminatesL. W. MCGINNIS, J. S. TATNALL,  
AND G. H. MAINS, *National  
Vulcanized Fibre Co.,  
Yorklyn, Del.*

The Houghton Laboratories developed on a small sheet scale for the Signal Corps an improved copper foil laminate from bond and dip solder standpoint. This paper describes the development of this into a commercial continuous process for producing a uniform and contaminant free cupric oxide layer on one surface of copper foil.

Present production unit handles 20 in. wide electrolytic or rolled copper. Coated with a suitable adhesive and molded into XXXP laminates, values of 12-15 lbs. bond strength and 260°C dip solder are obtained. This provides new ample leeway for printed circuit manufacturing processes.

## SESSION XXXVI\*

WED. 2:30-5:00 P.M.

WALDORF-ASTORIA  
ASTOR GALLERY

## Over-the-Horizon Systems

Chairman: KENNETH BULLINGTON,  
*Bell Telephone Labs.,  
New York, N. Y.*36.1. VHF Transhorizon Com-  
munication System DesignR. M. RINGOEN, *Collins Radio  
Co., Cedar Rapids, Iowa*

The basic properties of a signal received over a typical vhf transhorizon circuit are presented. The necessary parameters and features of a system designed to utilize efficiently this signal are then considered. These include modulation, diversity reception, data transmission, frequency control, equipment reliability and duplex operation. In conclusion, curves are presented showing system capacity and quality as a function of circuit length, reliability required and frequency. It is concluded that available vhf equipment may be employed to provide reliable voice transmission and extremely reliable multichannel teletype transmission for circuits in the 300 to 1,200 mile range.

36.2. Over-the-Horizon Radio  
Transmission Tests Between  
Florida and CubaK. P. STILES, *American Tele-  
phone and Telegraph Co.,  
New York, N. Y.*

Path loss tests on an over-the-horizon basis were conducted for six months early in 1955 between the southern part of Florida and several locations in Cuba. A frequency of 800 mc was used for the tests.

The method of making the tests and tabulating data is discussed. A comparison is made of the results obtained at the several receiving locations. Conclusions are drawn as to the range of fading to be expected and the suitability of the route for use in establishing a wide band radio system capable of carrying a number of voice circuits.

\* Sponsored by the Professional Group on Communications Systems. To be published in Part 8 of the IRE Convention Record.

### 36.3. A Broad-Band Over-the-Horizon Link for Florida to Cuba

R. T. ADAMS, H. HAVSTAD,  
L. POLLACK AND W. SICHAK,  
*Federal Telecommunication  
Labs., Nutley, N. J.*

A number of problems arise when it is desired to interconnect a broad-band line-of-sight radio communication facility and an over-the-horizon system. The solutions to these problems, such as what type of modulation to use or what overall bandwidth is required, will be discussed.

An over-the-horizon radio link will be established between Florida and Cuba (185 miles) before the end of 1956. The radio equipment is designed to handle one television channel and hundreds of telephone channels simultaneously in each direction. Frequency modulation is used with a radio bandwidth of 20 mc in the 600-900 mc band. Sixty foot diameter antennas, 10 kw klystron amplifiers, and low noise receivers are used. The diversity combiner, which operates at IF, and the problems encountered in obtaining the required bandwidth in the fm exciter, klystron amplifier, and receiver will be discussed.

### 36.4. An Over-the-Horizon Radio Link Between Puerto Rico and the Dominican Republic

R. E. GRAY AND R. A. FELSENHOLD,  
*Federal Telecommunication  
Labs., Nutley, N. J.*

A study of ways of providing additional communication facilities between Puerto Rico and the Dominican Republic indicated that the most desirable solution would be a uhf over-the-horizon multichannel radio link with one terminal located near San Juan in Puerto Rico, and the other at Ciudad Trujillo in the Dominican Republic, a distance of about 240 miles. After a survey of the terrain had been made, it was decided to conduct radio propagation tests over the proposed path. From the measured transmission loss, it is estimated that a transmitter power of 10 kw and an antenna gain of 35 db at each end of the link will provide seven voice channels with a reliability of 99 per cent.

This paper will include a discussion of problems of system planning, equipment, installation, as well as the economic factors in commercial over-the-horizon links.

### 36.5. Relative Interference Produced by UHF Scatter and Line-of-Sight Systems

R. M. RINGOEN,  
*Collins Radio  
Co., Cedar Rapids, Iowa*

Because most uhf transhorizon communications systems employ transmitter powers of 1 kw or greater, it is generally thought that the interference produced by a transhorizon system will be greater than that caused by a line-of-sight relay system performing the same service. The interfering effects of both the transhorizon and line-of-sight relay systems are computed using parameters of existing equipment. A unit of interference defined as a "square mile-megacycle" is introduced and the interfering properties of each system are expressed, using this term, for different sets of

assumed conditions. The results demonstrate the fact that contrary to general belief line-of-sight relay systems are more wasteful of spectrum than transhorizon systems. This should be an important factor in determining to what extent uhf transhorizon systems may be employed in areas where spectrum congestion may exist.

## SESSION XXXVII\*

WED. 2:30-5:00 P.M.

### WALDORF-ASTORIA JADE ROOM

#### Color Television Receivers

Chairman: HARLAND A. BASS,  
*AVCO Mfg. Corp., Cincinnati,  
Ohio*

### 37.1. The "Chromatron" as the Basis for Low-Cost Television Receivers

R. D'AMATO, R. DRESSLER, AND  
A. JACOBS,  
*Chromatic Television  
Labs., Inc., New York, N. Y., J. R.  
CLURMAN AND S. DECKER,  
Telechrome Manufacturing  
Co., Amityville, N. Y.*

The paper will describe the design of a low-cost television receiver utilizing a single-gun Lawrence tri-color cathode ray tube. The design makes use of a self-decoding technique and allows the encoded color television signal to be placed directly onto the color cathode ray tube grid, just as the monochrome television signal is placed onto a black-and-white kinescope.

This receiver fulfills the requirement that a color television receiver should not be basically more complex than a black-and-white receiver. The paper compares this low-cost receiver to a standard black-and-white receiver and analyzes similarities and differences.

### 37.2. The Optimum Relative Phosphor Efficiencies

S. K. ALTES,  
*General Electric  
Co., Syracuse, N. Y.*

In less than perfect color picture tubes, mutual contamination of the three primary colors is bound to occur. The degree to which a certain percentage of stray electrons deteriorates the picture quality is strongly dependent on the relative efficiencies of the three phosphors. The commonly used phosphors are far from ideal in this respect, the red being too inefficient.

The effective efficiency of the best phosphors can easily be reduced by the use of colored safety glass.

No single optimum exists for the relative efficiencies. It is dependent on the picture content and on the picture tube type.

\* Sponsored by the Professional Group on Broadcast and Television Receivers. To be published in Part 3 of the IRE Convention Record.

### 37.3. A New Color Television Display—The Apple System

J. S. BRYAN, R. G. CLAPP, E. M. CREAMER, S. W. MOULTON,  
AND M. E. PARTIN,  
*Philco  
Corp., Philadelphia, Pa.*

This paper describes a single-gun cathode-ray display system for color television receivers based on the phenomenon of secondary emission. An index signal, derived from a secondary emissive structure built into the screen of the tube, continuously indicates the position of the scanning spot relative to the color phosphor structure. This positional information is combined with the color television signal, and the combined signal modulates the scanning spot in amplitude and phase in such a manner that the spot sequentially illuminates the primary colors in the appropriate amounts and proportions to reproduce the intended scene. This paper describes 1) the general features of the system and the philosophy behind its development, 2) the derivation of the index signal and its utilization in the color-processing and grid-drive circuits, and 3) the requirements to be met in the color picture tube.

### 37.4. A Beam-Indexing Color Picture Tube—The Apple Tube

G. F. BARNETT, F. J. BINGLEY,  
S. L. PARSONS, G. W. PRATT,  
AND M. SADOWSKY,  
*Philco  
Corp., Philadelphia, Pa.*

This paper describes the color picture tube referred to in the preceding paper, its dimensions, materials of construction, deflection and focus systems, and the geometry and deposition of the phosphor and secondary-emissive screen materials. The construction and operation of the electron gun, which produces two independent beams of very small cross section from a single cathode, are described in detail. Life test data and pilot production experience are discussed.

### 37.5. Current Status of Apple Receiver Circuits and Components

R. A. BLOOMSBURGH, W. P. BOOTHROYD, G. A. FEDDE, AND R. C. MOORE,  
*Philco Corp.,  
Philadelphia, Pa.*

This paper reviews the components and circuits of a developmental color television receiver utilizing the Apple type of display. The block diagram of the complete receiver is presented, together with detailed diagrams of circuits peculiar to the display, *i.e.*, the index signal amplifier, color signal processing, high-voltage, horizontal sweep, and focus circuits. Photographs of the chassis layout and electron optical assembly are presented. The problem of integrating the circuits is outlined and typical receiver performance figures are stated.

## SESSION XXXVIII\*

WED. 2:30-5:00 P.M.  
WALDORF-ASTORIA  
SERT ROOM

## Telemetering Systems

Chairman: H. W. ROYCE,  
Glenn L. Martin Co.,  
Baltimore, Md.

## 38.1. Automatic Remote Control and Telemetering by Telephone

C. H. DOERSAM, JR., *Doerco-Consultants, Port Washington, N. Y.*

A system is described for remote control and telemetering. It is shown to be useful for a limited class of problems. The characteristics of these problems are outlined and general examples are given. The elements of the system are described. It is shown that a suitable communication link is a normal telephone connection. The special elements which make this possible are described. A specific example of this system is used to illustrate its capabilities and its limitations.

## 38.2. Noise and Crosstalk in Multiplexed FM Systems

R. A. RUNYAN, *Electro-Mechanical Research, Inc., Ridgefield, Conn.*

The equivalent of a spurious carrier adjacent to the desired carrier to frequency modulation at the difference frequency is derived. Based upon this derivative the function of band-pass input filters and low-pass output filters is discussed. In particular the effect of limiter and discriminator bandwidth on adjacent channel interference is derived. The main conclusions applied to fm/fm telemetry are: 1) channel noise is a function of output filter pass band and statistically is proportional to the square of the cutoff frequency, 2) crosstalk in a system of pulse averaging discriminators is reduced a negligible proportion if the band-pass filter produces a 4 db margin for the desired channel at the input to the limiter.

## 38.3. High Capacity Pulse Code Telemeter and Data Reduction System

G. S. SHAW, *Radiation, Inc., Melbourne, Fla.*

A report will be made on a high speed, high capacity pulse code telemeter which has also been designed for use as a data reduction system, not only for pulse code data but also pulse width, pulse amplitude, pulse time and fm/fm data. Some of the outstanding features of the system when used as a telemeter are: 1) 32 active information channels which can be subcommutated if desired, 2) 750 samples per second per channel, 3) over-all accuracy of  $\pm 0.4\%$ , 4) airborne recording of digital in-

formation if required, 5) quick-look records for editing made in real time on teledeltos chart. By using the airborne analog-to-digital converter and multiplexer this system can be used for high speed reduction of pulse width, fm/fm, pulse time and pulse amplitude data. After editing data from the quick-look recorder, the digitized data can be automatically programmed into high speed electronic computers for further processing and computation.

## 38.4. The Development of a High Speed Electronic Multiplexer and Coder for Use with a PCM Telemeter

R. P. BISHOP AND R. E. MARQUAND,  
*Radiation, Inc., Melbourne, Fla.*

The paper describes the development of a high speed electronic multiplexer and coder used in a 32 channel PCM telemetering system. The multiplexer samples each of the 32 channels at a rate of 750 times per second and commutates this information onto a single bus. The coder then digitizes each of these 24,000 samples of information per second into an eight digit binary code.

The multiplexer consists of three major types of circuit elements, a 32-stage sequential pulse generator, 32 pulse gates and a linear pulse stretcher circuit. The coder is of a feedback design employing the "half-split" sampling technique. The system operation is described and some of the circuit configurations are discussed.

## SESSION XXXIX\*

WED. 2:30-5:00 P.M.

KINGSBRIDGE ARMORY  
MARCONI HALL

## Electronic Computers—II

Chairman: JOHN H. HOWARD,  
*Burroughs Corp.,  
Paoli, Pa.*

## 39.1. A Magnetic Drum Sorting System

B. COX AND J. GOLDBERG,  
*Stanford Research Inst.,  
Menlo Park, Calif.*

A recently announced electronic accounting machine (ERMA) is required to file 50,000 items a day to magnetic tape storage. The filing proceeds continuously during the day and utilizes a magnetic drum as a temporary storage device. Each item is identified by an index number; the items are entered to the machine sequentially in random index number, but are stored on magnetic tape in numerical order. The sorting operation occurs between drum and tape and is accomplished by a unique electronic sorter, which is characterized by its ability to scan a large number of drum tracks simultaneously with but a single index number register and a minimum of associated logical circuitry. The system is further characterized by a small number of writing-erasing operations per item.

## 39.2. A Magnetic Drum Extension to the Gamma 3 Computer

P. L. DREYFUS, H. G. FEISSEL,  
AND B. M. LECLERC, *Compagnie  
Des Machines Bull., Paris,  
France*

The BULL Gamma 3, a production line computer, was primarily designed with a small internal storage to be connected to standard punched card machines.

An extension including a magnetic drum and high speed storage may now be connected to the existing model, increasing a thousand fold its internal storage.

This paper will describe logical and technological problems involved in this connection and some basic features of drum circuitry.

## 39.3. The Univac Magnetic Computer—Part I. Logical Design and Specifications

A. J. GEHRING, L. W. STOWE,  
AND L. D. WILSON, *Remington  
Rand Univac Division of  
Sperry Rand Corp.,  
Philadelphia, Pa.*

This paper describes a two address, decimal serial, binary parallel computer which uses about 1,500 magnetic core devices together with germanium diodes to perform all arithmetic and control functions. The arithmetic element uses four magnetic one-word registers of the recirculating type. A six-bit static register stores instruction digits and drives a switching matrix to produce needed control signals. A two-phase square-wave clock operating at 660 kc drives the two standard types of series magnetic amplifiers. These amplifiers and all other circuitry in the computer are packaged on plug-in, printed-wiring panels of seventeen types. Memory is provided by a magnetic drum rotating at 16,500 rpm which stores 2,000 machine words.

## 39.4. The Univac Magnetic Computer—Part II. Megacycle Magnetic Modules

B. K. SMITH, *Remington Rand  
Univac Division of Sperry  
Rand Corp., Philadelphia,  
Pa.*

Through intelligent packaging, mass-production economy is possible on even unique or specialized computers. The magnetic amplifier, adaptable to all normal vacuum-tube computer functions, has proved a satisfactory module. This paper points out that, in consideration of the properties of magnetic materials, a new philosophy of design is required. This philosophy entails close collaboration of logicians, designers, packaging engineers, and research physicists, from the beginning of the development of a computer.

Through new miniaturization techniques and improved magnetic materials, Sperry Rand Corporation has obtained reliable results from magnetic amplifiers at frequencies over 2 mc. Development of useful computer forms to replace common logical circuits is discussed.

Criteria for the selection of the type of logic are considered, and single-layer logic is offered as the optimum logic for this application.

\* Sponsored by the Professional Group on Telemetry and Remote Control. To be published in Part 1 of the IRE Convention Record.

\* Sponsored by the Professional Group on Electronic Computers. To be published in Part 4 of the IRE Convention Record.

### 39.5. The Univac Magnetic Computer—Part III. Drum Memory

V. J. PORTER, S. E. SMITH, AND  
M. NAIMAN, *Remington Rand  
Univac Division of Sperry  
Rand Corp., Philadelphia,  
Pa.*

A magnetic drum-memory with a capacity of 110,000 bits at an operation frequency of 658 kc is described. Storage includes 24,000 bits at a maximum access time of 0.9 millisecond and 72,000 bits at 3.6 milliseconds, with the remainder for sprocket and timing functions.

The memory is sealed in helium to protect it against corrosion, reduce input power, and improve heat dissipation. The drum's high speed (16,600 rpm) and high pulse-density ensure the short access times and the high bit-rate.

A method of magnetic-head construction is described which makes for a compact structure and facilitates the precise locations of heads in respect to the drum.

## SESSION XL\*

WED. 2:30-5:00 P.M.

### KINGSBRIDGE ARMORY FARADAY HALL

#### Antennas and Propagation— Microwave Antennas

*Chairman:* LESTER C. VAN ATTA,  
*Hughes Aircraft Co.,  
Culver City, Calif.*

#### 40.1. High Efficiency Metallized Fiberglas Microwave Lens

R. L. SMEDES, *Sperry Gyroscope  
Co., Division of Sperry Rand  
Corp., Great Neck, N. Y.*

The electrical design of a high efficiency, constrained, variable index of refraction, two point correction lens is described. The lens produces a 2 degree azimuth beamwidth by a 2.7 degree elevation beamwidth and is capable of being scanned more than 25 degrees either side of the lens axis. The variable index of refraction loading structures are discussed and the methods used to reduce lens surface reflections are described. Secondary radiation patterns and aperture efficiency of the experimental lens are presented for various angles of scan over a broad band.

Comments on a novel technique for overcoming the manufacturing problems with this type of structure are included.

#### 40.2. Ferrrod Radiator Systems

F. REGGIA, E. G. SPENCER, R. D.  
HATCHER, AND J. E. TOMPKINS,  
*The Diamond Ordnance Fuze  
Lab., Washington, D. C.*

Systems of end-fire X-band radiators using ferrite rods of high dielectric constant are described. Magnetic fields are applied to switch the radiation on and off, change the mode of radiation, shift the phase, or rotate the plane of polarization.

The pattern of a single ferrite rod radiator 0.24 in. in diameter and 3 in. long is characterized by a beam width of 20°, side lobes 20 db down, and zero back lobes. A 2×2 element square array is compared with a horn having a gain of 100 and the results of measurements on linear multi-element arrays are described.

Patterns are given as a function of angle of beam scan for linear scanning arrays; and a useful low field ferrite 360° phase shifter is described. Beam lobing of arrays is accomplished by the use of any of three novel types of ferrite switches for which isolation requirements are not as stringent as those usually demanded.

#### 40.3. A Design Method for Very Long Linear Arrays

M. G. CHERNIN AND R. W. BICK-  
MORE, *Hughes Aircraft Co.,  
Culver City, Calif.*

A method for designing a very long, non-resonant, linear array has been developed in which the array is considered to consist of a finite number of elements in tandem. Each element is made up of a group of identical slots and is assumed to reflect a negligible amount of power. The number of slots in each element depends on the aperture taper and on the minimum manufacturing tolerance. The array design formula is presented in both recursion and series form. Design calculations enable either the dissipative attenuation in db for each element or an equivalent element conductance to be determined. The design method was used in conjunction with the construction of an array several hundred wavelengths long. The resultant antenna pattern and input vswr are described.

#### 40.4. Some New Antenna Designs Based on the Trough Waveguide

WALTER ROTMAN AND NICHOLAS  
KARAS, *Laurence G. Hanscom  
Field, Bedford, Mass.*

Several new antenna designs, based upon the use of the trough waveguide as a transmission line, have recently been conceived. These include linear arrays made of resonant or non-resonant monopoles, slow wave structures, a hybrid type of TEM to trough guide mode converter, and a tri-pole-variable coupler. The trough guide, which was recently discovered by the personnel of Airborne Instruments Laboratory, Inc., is admirably suited for these applications because of its unusual geometry, simple mechanical construction, and broad-band characteristics.

Several typical examples, including design data for a fixed beam linear antenna array in trough guide, demonstrate superior properties as compared to the conventional slots or dipoles in rectangular waveguide.

#### 40.5. Future Trends in Radomes for Ground Electronic Equipment

M. V. RATYNSKI, *Griffiss Air  
Force Base, Rome, N. Y.*

This paper summarizes the state of the art and describes the future trends of rigid, air-supported, air-wall and other types of radomes. The design problems of large-scale electronic installations in arctic, temperate, and tropical regions, call for more diversified use of, and a greater dependence on shelters for antennas and other electronic equipments. The trend to larger sizes in the order of 200 to 500 feet in diameter requires an entirely different approach to the problem. Wide frequency bands place stringent radio frequency transmission requirements on the choice of materials and constructional techniques. Discussed, will be some new approaches to the problem. Practical designs offering possible solutions will be suggested.

#### 40.6. A Toroidal Microwave Reflector

G. D. M. PEELER AND D. H.  
ARCHER, *Naval Research  
Lab., Washington, D. C.*

A toroidal reflector has been designed for applications requiring wide angle scanning of a microwave beam over a plane in space. The optimum generating curve for this surface of revolution reflector is determined by averaging the absolute values of weighted phase errors over the illuminated reflector area. Phase errors of this reflector are approximately one-half as large as those from the parabolic torus, which is superior to other reflectors for these applications. Radiation patterns from experimental reflectors will be presented.

## SESSION XLI\*

THURS. 10:00 A.M.—12:30 P.M.

### BELMONT PLAZA MODERNE ROOM

#### Circuits II—Design and Appli- cation of Active Networks

*Chairman:* WILLIAM R. BENNETT,  
*Bell Telephone Labs.,  
Murray Hill, N. J.*

#### 41.1. On the Driving-Point Im- pedance Functions of Active Networks

N. DECLARIS, *M.I.T.,  
Cambridge, Mass.*

A general theorem is presented that relates three arbitrary terminal-pairs of a linear circuit by means of network parameters—impedance or admittance functions. It is shown that this is a generalization of Thevinin's theorem, leading to considerable simplifications in the driving-point analysis of active networks.

The class of active networks containing only one active element, or their equivalent, is considered in detail. Some properties of the driving-point impedance functions of such net-

\* Sponsored by the Professional Group on Antennas and Propagation. To be published in Part 1 of the IRE Convention Record.

\* Sponsored by the Professional Group on Circuit Theory. To be published in Part 2 of the IRE Convention Record.

works are stated in the form of existence theorems.

Synthesis techniques for two particular types of active network configurations are presented and illustrated.

#### 41.2. Active Network Synthesis

##### I. HOROWITZ, *Microwave Research Inst., Brooklyn, N. Y.*

A general approach to active network synthesis is presented, with the active non-reciprocal element represented as a controlled source which can be manipulated in a manner similar to passive elements. The controlled-source representation (rather than a gyrator-negative resistance representation) leads to definite advantages in flexibility, in the ability of the synthesis procedure to take into account unavoidable bias elements and parasitics, and in the realization of a given transfer function with a small number of tubes or transistors.

Application of this philosophy to the specific problem of realization of transfer functions in the form of active RC ladder networks, leads to a variety of synthesis procedures to realize poles in the left half plane and zeros anywhere in the complex plane. The basic philosophy of synthesis is the step-by-step ladder realization of the required driving-point function in such a way as to realize the desired transmission zeros.

Examples are given involving tubes and transistors.

#### 41.3. Some Considerations on the Stability of Active Two-Port Elements and Applications

##### A. P. STERN, *General Electric Co., Syracuse, N. Y.*

If properly terminated, a non-unilateral active two-port network can become unstable even in the absence of external feedback. This paper discusses some aspects of the stability problem.

Valuable information regarding potential instability can be obtained by analyzing the driving point immittances as functions of the terminal immittances using a generalized matrix representation of the network. The region of potential instability is either the interior or the exterior of a circle in the terminal immittance plane. A simple relationship between network parameters can be established as the necessary condition of stability for all passive terminations. Similarly, relationships can be derived for stability with other desirable terminations.

The theoretical conclusions are useful and are applied to the vacuum tube and to the transistor (in common emitter, base and collector configurations). Stability conditions for various circuits using these devices are derived.

#### 41.4. Two Invariants of Noisy Linear Amplifiers

##### H. A. HAUS AND R. B. ADLER, *M.I.T., Cambridge, Mass.*

This work concerns the single-frequency noise performance of linear, active, two-terminal-pair networks with internal noise generators.

Two parameters of any active network, expressible in terms of its impedance matrix and open-circuit noise voltages, are found to be invariant when it is imbedded in any arbitrary,

lossless (reciprocal or nonreciprocal) network to produce a new two-terminal-pair system.

An important class of amplifiers can be brought, by means of lossless feedback, into a unilateral form in which the open-circuit input and output impedances are guaranteed to have positive real parts. One simple interpretation of the invariants is that they determine, for this class of amplifiers, the minimum value of the expression  $M = (F-1)/(1-1/G)$  attainable by means of proper end-loading of the unilateralized amplifier, where  $F$  is the spot noise figure, and  $G$  is the available gain. It is shown further that the same minimum value for  $M$  can be reached, but not improved upon, by proper end-loading of the amplifier in a non-unilateral and unconditionally stable circuit connection.

These results, and some others demonstrating the invariance properties of  $M$ , suggest that the quantity  $M$  be adopted, instead of the noise figure  $F$ , as a quantitative measure of amplifier noise performance.

#### 41.5. Graphical Analysis of Transistor Circuits by Separation of Variables

##### D. L. FINN AND B. J. DASHER, *Georgia Institute of Technology, Atlanta, Ga.*

In this paper a method is shown by which the technique of separation of variables may be applied to the graphical solution of a wide variety of nonlinear circuit problems. The method utilizes only the voltage and current equilibrium equations of the circuit and the static characteristic curves of the nonlinear elements in the circuit.

The method provides a straightforward means of determining the dynamic operating-paths of the circuit on the static characteristic curves of the nonlinear elements. The technique of separation of variables is demonstrated by the analysis of two simple transistor circuits. In both of these, the dynamic operating-path for the circuit is plotted on the static characteristic curves of the transistors by use of the separation of variables procedure. Points on these dynamic operating-paths are then used to calculate the desired information about the operation of the transistor circuit.

Graphical analysis by separation of variables as described here is probably most useful for the analysis of transistor circuits; however, it may also be applied to the analysis of many types of feedback networks that employ vacuum tubes or gas tubes.

### SESSION XLII\*

THURS. 10:00 A.M.—12:30 P.M.

#### WALDORF-ASTORIA STARLIGHT ROOF

#### Electronic Computers III— Symposium on the Impact of Computers on Science and Society

\* Sponsored by the Professional Group on Electronic Computers. To be published in Part 4 of the IRE Convention Record.

#### Chairman: THEODORE H. BONN, *Sperry Rand Corp., Philadelphia, Pa.*

The recent development of digital and analog computers has had a profound effect on science and technology. Science has been given a new tool—the ability to perform calculations that were heretofore considered impossibly complex and time consuming. In addition, the development of computers as a branch of technology has contributed to the generation of new ideas, which in turn are affecting other disciplines. How are these events shaping the course of scientific research and technological development? On what new goals are scientists focusing their attention now that computers are available to them?

How will these new tools of science affect our daily lives? What problems will they present and what benefits does the future hold?

A panel of distinguished speakers will talk on the above problems. At the conclusion of prepared talks, there will be a round table discussion of the problems raised.

#### 42.1. A. V. ASTIN, *National Bureau of Standards, Washington, D. C.*

#### 42.2. R. E. MEAGHER, *University of Illinois, Urbana, Ill.*

#### 42.3. D. SAYRE, *International Business Machines Corp., New York, N. Y.*

#### 42.4. J. W. FORRESTER, *M.I.T., Cambridge, Mass.*

### SESSION XLIII\*

THURS. 10:00 A.M.—12:30 P.M.

#### WALDORF-ASTORIA ASTOR GALLERY

#### Color Television

#### Chairman: DONALD G. FINK, *Philco Corp., Philadelphia, Pa.*

#### 43.1. Recent Improvements in the 21AXP22 Color Kinescope

#### R. B. JANES, L. B. HEADRICK, AND J. EVANS, *Radio Corporation of America, Lancaster, Pa.*

The 21AXP22 has proven to be a high-quality color kinescope which is readily adaptable to quantity production. As a result of manufacturing experience in the making of

\* Sponsored jointly by the Professional Groups on Broadcast and Television Receivers and on Electron Devices. To be published in Part 3 of the IRE Convention Record.

thousands of tubes and changes made in the construction and processing, nearly perfect color purity and white uniformity have been achieved. A good deal of the processing improvements are due to changes made in the "lighthouse" on which the phosphor screens are exposed. After a brief review of the principles of the tube and data on its operation, both the tube and lighthouse changes are explained. Equipment used to obtain the data for changes is also described.

#### 43.2. G.E. Post Acceleration Color Tube

C. G. LOB, *General Electric Co., Syracuse, N. Y.*

The tube to be described is a three gun type which employs a high transparency parallel wire grille at the front end together with post acceleration to cause each of the three beams to strike its associated phosphor array.

The high percentage beam utilization allows for considerably improved brightness capabilities. Post acceleration focusing which occurs at the front end makes possible wide mechanical and electrical operating tolerances.

The underlying theory of operation, pertinent constructional features, together with complete performance information will be presented.

#### 43.3. Correct Prints of Color Tube Screens

H. HEIL, *General Electric Co., Syracuse, N. Y.*

Application of an accelerating field between the mask and the screen of a color tube in effect destroys the geometrical similitude between mask pattern and screen pattern. Also because of the post acceleration focusing action at the mask, the mask itself cannot serve as printing master as it does for shadow mask tubes.

Procedures for obtaining prints the elements of which have the proper size and proper placement on the screen are reported. The method of calculating grinding data for the optical elements required is given.

Color purity defects produced by the yoke, by dynamic convergence, and by small magnetic fields and their optical simulation are discussed.

#### 43.4. The Unipotential Mask-Focusing Colortron

N. FYLER, C. CAIN, AND P. HAMBLETON, *CBS-Hytron, Newburyport, Mass.*

This paper describes a tri-beam color tube employing the basic constructional features and advantages of the previous Colortron picture tubes with the addition of an electron beam focusing action between aperture mask and phosphor screen. In the subject tube, the mask transmission and corresponding efficiency and light output has been greatly improved.

The specific configuration of the electrode system and the potential distribution are such as to give the advantages of: focusing action between the curved mask and faceplate without the use of additional mesh or grill structures; a premask potential high enough to assure excellent beam resolution and to effectively collect secondaries for high contrast pictures; and the use of a phosphor dot array that is a

simple optical image of the mask which is used as a photographic negative. In the preferred form of the improved tube only one supplementary electrode lead and corresponding voltage is required.

Design parameters and performance data are discussed. The specific construction of both round and rectangular tubes is described.

#### 43.5. Focusing Grill Color Kinescopes

E. G. RAMBERG, H. B. LAW, H. S. ALLWINE, D. C. DARLING, C. W. HENDERSON, AND H. ROSENTHAL, *RCA Labs., Princeton, N. J.*

Color dilution and contrast reduction by secondary and backscattered electrons in tri-color focusing mask kinescopes with line screens may be suppressed by the addition of a second grill or mesh electrode. A study has been made of the electron-optical principles of such systems and the correction of residual focusing errors.

Three systems of focusing mask color kinescopes incorporating the above principle for minimizing the adverse effects of secondary emission and backscattering have been investigated experimentally. Their performance has been in substantial agreement with expectation.

### SESSION XLIV\*

THURS. 10:00 A.M.-12:30 P.M.

#### WALDORF-ASTORIA JADE ROOM

##### Component Parts I

*Chairman: GUSTAVE SHAPIRO, National Bureau of Standards, Washington, D. C.*

#### 44.1. The Power Supply in Military Equipment

SOL PERLMAN, *Griffiss Air Force Base, Rome, N. Y.*

The power supply for a great many military electronic equipments is wasteful of power. The wasted power, which is converted into heat, affects the reliability of the military electronic equipment. The still poorer performance of regulated power supplies aggravates the situation. Examples of such situations are discussed. An investigation of the application of silicon power diodes shows that benefits of transformer and filter choke redesign permit a marked reduction in power waste. A new approach to the regulated power supply design is discussed. Measured data are quoted to show the reduction in power waste and the contribution to reliability improvement.

#### 44.2. The Silver-Zinc Rechargeable Battery

PAUL HOWARD, *Yardney Electric Corp., New York, N. Y.*

\* Sponsored by the Professional Group on Component Parts. To be published in Part 6 of the IRE Convention Record.

A silver-zinc alkaline storage battery, developed by Henri André, is now in production; it approaches the ideal zero-impedance source sought by electronic engineers. The basic theory and characteristics are outlined. Operational parameters as to temperature, available currents, discharge characteristics and cell types are discussed, as well as data on the improvement of low-temperature performance by special shorting technique through a current-limiting device to warm up the battery sufficiently for normal performance. By proper preparation, units may be kept in charged storage for prolonged periods without serious capacity loss. Flat output voltage characteristics have elicited interest from transistor engineers for transistor regulation. Due to its particular characteristics, the cell has an output of approximately five times that of conventional batteries for the same space and weight, thus finding application where weight and space are at a premium.

#### 44.3. The Wafer Coil Pulse Transformer

ALFRED BABCOCK AND ALBERT ZACK, *Sylvania Electric Products, Inc., Ipswich, Mass.*

Wafer coils used in the manufacture of pulse transformers have provided a simple economical means to achieve a small, compact unit with improved electrical characteristics. The wafers that comprise the transformers are aluminum or copper foil wound coils. This article discusses the latest methods used to manufacture wafer coil transformers and the many possible shapes and sizes obtained.

The electrical characteristics and their improvements over the conventional wound pulse transformers are discussed in full and performance of wafer coil pulse transformers in various applications is reviewed. Its application as a blocking oscillator, pulse amplifier and impedance matching transformer make wafer coil pulse transformer an asset to modern electronics.

#### 44.4. Developments in Magnetic Component Packaging

A. LUCIC, *North American Aviation, Inc., Downey, Calif.*

The progress in development of newer and better types of transformer and reactor encapsulation and potting methods is described. This includes discussion of transition from "Open-Type" units to NAA plastic cased types.

A discussion of the ability of these new plastic cased components to meet the increasingly difficult requirements of Military Specifications and Airborne Electronic Applications is presented.

Photographs illustrating various magnetic component types developed, data concerning electrical and mechanical properties of cases and resins used, and cost studies comparing construction costs on newer and older types of magnetic components are included.

#### 44.5. A Compact High-Voltage Power Supply Design Using A Transistor Inverter Circuit

MORRIS CHESTER, *Westinghouse Electric Corp., Baltimore, Md.*

The design requirements of a high-voltage radar scope supply are reliability, ruggedness, compactness and good regulation. The conventional approach of a 60-cycle, full wave voltage doubler supply required a voltage regulating tube because of the allowable input voltage variations. (The supply transformer must have sufficient voltage output to satisfy negative line voltage tolerance and must be insulated to withstand maximum positive line voltage tolerance.) Because of the large number of turns of any practicable wire size, a 60-cycle supply is necessarily large and bulky. A high-frequency rf high-voltage supply has the disadvantages of an extra tube and critical tuning adjustments. The high-voltage supply described here embodies a switching transistor inverter and saturating transformer suggested by Bright, Pittman and Royer. It makes use of a low voltage regulated dc supply already available for other purposes.

The transformer operates at 1,000 cps. It meets the regulation requirements, has no tuning adjustments, and is considerably smaller and lighter than the conventional 60-cycle supply. Winding the high-voltage toroid involves insulation problems.

The scope of this paper is the design of such a supply. It describes the circuit operation and covers considerations of frequency, core material and transistor performance. Four solutions to the toroid high-voltage winding problem with their advantages and limitations are compared, in order to arrive at a practical toroid transformer design.

The advantages of this arrangement suggests its use whenever a rugged, compact, efficient high-voltage low-current supply is required.

## SESSION XLV\*

THURS. 10:00 A.M.—12:30 P.M.

WALDORF-ASTORIA  
SERT ROOM

Industrial Electronics

Chairman: ERIC W. LEAVER,  
*Electronic Assoc., Ltd.,  
Willowdale, Ontario,  
Canada*

### 45.1. High-Frequency Shields

R. E. LAFFERTY, *National  
Broadcasting Co., New  
York, N. Y.*

A method is described which uses either conventional laboratory equipment or algebraic equations to closely approximate the effectiveness of a cylindrical rf shield. The shielding factor (attenuation) is shown to be equal to the  $Q$  of the shield and a means of measuring the  $Q$  is developed. Equations for  $Q$ , based on the physical properties of the shield, are also derived.

The  $Q$  measurements, as well as the calculations, are substantiated by field strength measurements and are also shown to agree with other published material in related fields. Curves demonstrate the effect of changing the frequency, shield thickness, material, and the ratio of the shield length to diameter.

\* Sponsored by the Professional Group on Industrial Electronics. To be published in Part 6 of the IRE Convention Record.

### 45.2. Field-Intensity Measurements on Induction-Heating Equipment

T. E. NASH, *Radio Corporation  
of America, Lancaster, Pa.*

This paper describes the program undertaken at RCA's Lancaster, Pa., plant to reduce and measure radio-frequency radiation from a large number of induction-heating equipments. The Lancaster plant is a complex radiating source containing more than 100 separate installations which operate over a frequency band from 150 kilocycles to 15 megacycles and include frequencies from the fundamental through the tenth harmonic. The program, which required the better part of two years to complete, consisted of three main steps: 1) determination of the magnitude of the radiation, 2) modification of equipment to reduce radiation to an acceptable level as prescribed by FCC requirements, and 3) the actual certification measurements.

### 45.3. Basic Considerations in the Design of Electronic Power Supplies for Electrodynamical Shakers

D. J. FRITCH, *The Calidyne Co.,  
Winchester, Mass.*

The designer of an electronic power supply for an electrodynamic shaker is faced with the problem of supplying large amounts of power to a load which varies considerably in impedance and power factor throughout the frequency range of interest. The electrical characteristics of the shaker are discussed and the load requirements it imposes on a power supply are presented. The possibility of over-dissipation in an electronic power supply at certain frequencies as a result of the load impedance variations is examined and an approach to the design of an optimum amplifier for supplying shakers is presented.

### 45.4. Magnetic Amplifier Industrial Control Techniques for Improved Accuracy and Reliability

H. W. PATTON, *Airpax Products  
Co., Baltimore, Md.*

Early industrial control systems did not require good accuracy. Their inherent simplicity did not reduce system performances significantly. As control operations became more complex, the vacuum tube was employed in many applications in great numbers. This reduced system reliability to an undesirable degree. Certain operations such as amplification of millivolt dc signals, servo lead-lag compensation and dc signal mixing with input information isolation were difficult to perform. The paper to be presented will discuss these problems and show basic magnetic amplifier techniques for: 1) amplification of low level dc signals, 2) mixing low level dc signals with circuit isolation, 3) typical methods of providing lead and lag networks for servo systems. A typical system will be shown using these techniques to demonstrate their application.

## SESSION XLVI\*

THURS. 10:00 A.M.—12:00 NOON

WALDORF-ASTORIA  
GRAND BALLROOM

Information Theory II

Chairman: WINSLOW PALMER,  
*Sperry Gyroscope Co.,  
Great Neck, N. Y.*

### 46.1. Certain Aspects of Coherence, Modulation, and Selectivity in Information Transmission Systems

STANFORD GOLDMAN, *Syracuse  
University, Syracuse, N. Y.*

An analysis is given of the coherence properties of signals and the way in which they can be used to improve signal-to-noise ratio. It is shown that the coherence properties are the basis of two different types of selectivity which exist in information transmission systems. Type I selectivity is based upon signal power whereas Type II selectivity usually hinges upon bandwidth. The characteristics of modulation systems and of tropospheric propagation are discussed, particularly as related to their coherence properties. Conclusions are drawn concerning characteristics of modulation systems which would be suitable for tropospheric propagation.

### 46.2. Some Results in Coding Theory

CLAUDE SHANNON, *Bell Telephone  
Labs., Murray Hill, N. J.*

### 46.3. Session Commentary

PETER ELIAS, *M.I.T.,  
Cambridge, Mass.*

### 46.4. Factors Determining the Channel Capacities and Design Constraints in Groups of Nerve Fibers

P. D. WALL, J. Y. LETTVIN, W. S. McCULLOCH AND W. H. PITTS,  
*M.I.T., Cambridge, Mass.*

Nerves that connect receptors of skin, muscle, and joint to the spinal cord have thousands of fibers. Each fiber can transmit a thousand all-or-none signals per second to the point in the spinal cord where it divides into descending and long ascending limbs whose branches end on nerve cells. At branch-point signals in the same and in neighboring fibers,

\* Sponsored by the Professional Group on Information Theory. To be published in Part 4 of the IRE Convention Record.

prevent transmission of incoming signals at short intervals. We have measured the loss in the ascending limbs and computed an upper bound on their information capacity if used in pulse-interval modulation.

## SESSION XLVII\*

THURS. 10:00 A.M.—12:30 P.M.

KINGSBRIDGE ARMORY  
MARCONI HALL

Microwaves III—Filters

Chairman: G. C. SOUTHWORTH  
Chatham, N. J.

### 47.1. Directional Channel-Separation Filters

S. B. COHN AND F. S. COALE,  
Stanford Research Inst.,  
Menlo Park, Calif.

A class of frequency-selective networks is described that combines the properties of a directional coupler and a conventional filter. These networks, which will be called *directional filters*, are particularly suited for combining or separating signals of different frequencies in communication systems, for multiplexing several equipments connected to a single antenna, etc. A signal entering one arm of the network will be transferred with essentially zero loss to a second arm over a desired channel of frequencies, while at other frequencies the signal will emerge with little loss from a third arm. Over the entire frequency range the fourth arm is isolated and the first arm is nonreflecting.

Many new types of directional filters have been found, and will be described in this paper. Several of these are particularly easy to design and build in strip or coaxial line, while others lead to compact, economical structures in waveguide. Design information and experimental data will be included in this paper.

### 47.2. A Resonant Cavity Frequency Duplexer

E. O. BOWERS AND C. W. CURTIS,  
Hughes Aircraft Co., Culver  
City, Calif.

The problem of adding or removing a fixed frequency microwave signal from a waveguide line containing microwave signals of other relatively close frequencies can be solved by using filters containing precision narrow-band cavities. The design of such units to meet specific electrical requirements and a description of the solution of added problems caused by the extreme environmental conditions which may be found in field equipment are the subjects treated in this paper. A specific device is described which maintains its tuned frequency to 0.005 per cent over a wide range of environmental conditions.

\* Sponsored by the Professional Group on Microwave Theory and Techniques. To be published in Part 5 of the IRE Convention Record.

### 47.3. Synthesis of Wide-Band Microwave Filters to Have Prescribed Insertion Loss

E. M. T. JONES, *Stanford  
Research Inst., Menlo  
Park, Calif.*

This paper describes an exact technique for synthesizing a class of symmetrical non-dissipative low-pass and band-pass microwave filters that have either maximally-flat or equal-ripple pass band insertion-loss characteristics over any desired frequency range. These filters consist of a cascade of series and shunt transmission lines, all of equal lengths but with different characteristic impedances. Low-pass characteristics are obtained by open-circuiting the ends of the shunt lines, while band-pass characteristics are obtained by shorting the ends of the shunt lines. Examples of filters that can be synthesized by this technique are coaxial line filters, open-wire transmission line filters and strip-line filters.

### 47.4. Crossed-Mode Tunable Selector for Microwaves

N. A. SPENCER, *Wheeler Labs.,  
Great Neck, N. Y.*

A tunable bandpass filter has been designed for use as a microwave selector. It utilizes two crossed modes of resonance in one square-cylinder cavity, thereby obtaining double-tuned response in the volume of only one resonator, and requiring only one tuning plunger. The proper coupling between the crossed modes is obtained by a small diagonal pin. Tuning is accomplished by axial motion of a non-contact, cup-shaped plunger. In an X-band model, a bandwidth of 30 mc is achieved with an insertion loss of only 0.5 db. These characteristics are maintained over the range of 8.5 to 9.6 kmc.

### 47.5. The Susceptance of a Circular Iris to the Dominant $TE_{11}$ Mode in Circular Waveguide

MORRIS HANDELSMAN, *Griffiss  
Air Force Base, Rome,  
N. Y.*

The impedance behavior of a round iris obstacle in a circular waveguide propagating the dominant  $TE_{11}$  mode has been solved using a variational method based upon the tangential aperture electric field. The complete range of iris sizes has been investigated, from small to large. In addition the important effects of finite obstacle thickness have been taken into account, using a technique based upon methods developed by Marcuvitz and Oliner.

The trial aperture field for the large aperture case is similar to that of a  $TE_{11}$  mode. For the small aperture case, two different trial fields have been chosen. One is a field based upon published work by Bethe on the diffraction of small holes in screens; the other is based upon similar work by Bouwkamp. It is shown that the variational solutions for both fields reduce to the same equation in the limit of vanishingly small aperture size, and that this equation is identical with one previously published, which is derived by a non-variational method.

In order to compare theoretical results, and to obtain numerical values for comparison with published experimental data, it is necessary to accurately, or in some cases, exactly sum infinite series whose terms are Bessel functions. These series are either of the Schlomilch type, or are of the type where each term is the product of two Bessel functions, or the square of a Bessel function, etc. The Bessel functions are of the first kind, of integer or fractional order. These series have been summed by either exact closed-form formulas or have been converted into more rapidly convergent series suitable for numerical computation.

Graphical and tabular comparison is given between theoretical results and published experimental data taken by the Bell Telephone Laboratories and the Massachusetts Institute of Technology Radiation Laboratory, for all iris sizes and various thicknesses. The agreement is considered good.

## SESSION XLVIII\*

THURS. 10:00 A.M.—12:30 P.M.

KINGSBRIDGE ARMORY  
FARADAY HALL

Instrumentation II

Chairman: DAVID PACKARD,  
Hewlett-Packard Co.,  
Palo Alto, Calif.

### 48.1. A Method for Repetitive Examination of Transient Phenomena

J. W. DORSETT, JR., *Ampex  
Corp., Redwood City, Calif.*

A method of reading magnetic tapes by repetitive scanning of discrete, progressively-moving sections of the medium has been developed. This method effectively expands the information time base while maintaining the original signal frequencies. It is also possible by this technique to continuously examine any 33-millisecond interval of the recorded signal. Although originally developed to facilitate data reduction, the system is equally adaptable to speech analysis problems. The operating principles, basic design features and possible applications are described.

### 48.2. A Magnetic Head for the Megacycle Range

OTTO KORNEI, *Clevite Research  
Center, Cleveland, Ohio*

A magnetic transducer head for high frequencies presents two independent problems: its power losses must be low to yield a useful output and its resolution must be high to permit practical speeds of the recording medium.

A novel magnetic head is described which combines the low loss features of a ferrite core with the high resolution of a very short metallic transducer gap. Frequencies of over 4 mcps, recorded at a density approaching 20,000 cycles per inch, have been attained with a signal-to-noise ratio in the middle frequency range of over 30 decibels. Performance data and some structural details of both single and multi-channel heads are presented.

\* Sponsored by the Professional Group on Instrumentation. To be published in Part 5 of the IRE Convention Record.



### 48.3. Extending the Versatility of a Laboratory Magnetic Tape Data-Storage Device

A. V. GANGNES, *Ampex Corp., Redwood City, Calif.*

The fields of research and development encompass a vast number of processes requiring many different methods of acquiring, storing, and evaluating test information. This paper describes a system philosophy of instrument development that provides a device of sufficient versatility that a large variety of these data-handling applications can be fulfilled by a single machine. Attention is given to various encoding methods available, variation in volume of information to be stored, and the need for acquiring and evaluating analog data on different time bases. Particular emphasis is placed on efficient use of equipment space, component environment, and standardization of components, inasmuch as these factors directly affect reliability, cost, and serviceability.

### 48.4. A Time Bridge

M. B. KLINE AND C. E. WEBB,  
*Allen B. DuMont Labs., Inc., Clifton, N. J.*

Conventional bridge techniques may be applied to the time domain to permit measurements of delay time, phase shift, and characteristic impedance of an unknown. In a device using this idea, the standard arm contains a precise, calibrated, variable delay line to provide a known time delay over the range of measurements to be made. The unknown is connected in the adjacent arm. The ratio arms are adjusted to terminate the standard and unknown networks in their characteristic impedance. The null detector is ordinarily the deflection plates of a cathode-ray oscillograph.

A practical unit has been built which is capable of measuring delay time of 20  $\mu$ sec to 1.0 microsecond with accuracies up to 2 per cent, and with resolution up to plus or minus 1 millimicrosecond depending on the unknown.

Characteristic impedance from 50 to 5,000 ohms can be measured with 5 per cent accuracy.

Advantages and limitations of the system together with theoretical and practical design considerations are discussed.

### 48.5. A Versatile Quadrature Time Base Comparator for Automatic Frequency Measurement

I. J. WEBER, *Sperry Gyroscope Co., Great Neck, N. Y.*

The quadrature time base comparator is a novel form of automatic frequency measurement system within the range of 1 cps to 10k cps, to provide measurements without need for manual operation and/or human observation. The system provides high accuracy within short-time intervals, exceeding the capabilities of earlier methods. Its performance, accuracy, and relative ease of operation suggest possible use in production line and field testing of stable frequency sources.

The quadrature time base comparator utilizes an oscilloscopic method in which the quadrature sweep derived from a primary fre-

quency source is intensity modulated by the frequency to be measured. The time for the resultant mark or marks to rotate a known distance on the quadrature sweep is an indication of the frequency difference. This information is automatically recorded on a totalizer.

## SESSION XLIX\*

THURS. 2:30-5:00 P.M.

### BELMONT-PLAZA MODERNE ROOM

#### Circuits III—Network Synthesis Techniques

Chairman: MURLAN S. CORRINGTON, *Radio Corp. of America, Camden, N. J.*

#### 49.1. Simple and Double Alternation in Network Synthesis

F. REZA, *Syracuse University, Syracuse, N. Y.*

Analytical tests for stability or physical realizability of linear systems are generally complicated. However, there exists an inherent symmetry in practically all linear systems which can be exhibited by proper geometrical exposition. The object of this paper is to show the generation of positive real functions in the light of this inherent geometrical structure. Having this in mind, the simple alternation geometry of Routh-Hurwitz polynomial on a straight line is generalized into a double alternation theorem.

Theorem—Let

$$Z(s) = A \frac{m_1 + k_1 n_1}{m_2 + k_2 n_2}$$

be a positive real function with no poles and zeros on the axis of imaginaries.  $m_1$ ,  $m_2$ , and  $n_1$ ,  $n_2$  being respectively even and odd polynomials in  $s$  with no common quadratic factor and having unity for the coefficient of their highest degree. If the consecutive roots of these polynomials is  $s^2 = \lambda$  are respectively denoted by:

$$(\lambda_{12}, \lambda_{14}, \lambda_{16}, \dots), (\lambda_{22}, \lambda_{24}, \lambda_{26}, \dots), \\ (0, \lambda_{13}, \lambda_{15}, \dots) \text{ and } (0, \lambda_{23}, \lambda_{25}, \dots)$$

Then every internal consecutive pair of roots of  $m_1 m_2$  will alternate with a pair of internal consecutive roots of  $n_1 n_2$ .

$$0 > (\lambda_{12} \text{ and } \lambda_{22}) > (\lambda_{13} \text{ and } \lambda_{23}) \\ > (\lambda_{14} \text{ and } \lambda_{24}) > (\lambda_{15} \text{ and } \lambda_{25}), \dots$$

The application of the above theorem will considerably simplify the P. R. test and will be of further use in the generation of these functions.

#### 49.2. Synthesis of Tchebycheff RC Band-Pass Filters

D. HELMAN, *RCA Computing Systems, Camden, N. J.*

Methods for synthesizing RC filters have been presented by several authors. These

\* Sponsored by the Professional Group on Circuit Theory. To be published in Part 2 of the IRE Convention Record

methods, however, are limited to the case of low-pass or high-pass filters.

This paper presents a method for synthesizing an RC band-pass filter, which has a Tchebycheff transmission characteristic in the pass band and a monotonically decreasing transmission in the stop band. Since no limitation is placed on the position that the pass band occupies along the frequency axis, the results are applicable not only to band-pass filters, but also to low-pass and high-pass filters as special cases.

Maximum gain considerations for the filter in the pass band are also discussed.

#### 49.3. Pulsed RC Networks for Sampled-Data Systems

J. SKLANSKY, *RCA Labs., Princeton, N. J.*

A pulsed RC network is an RC network whose output is sampled in synchronism with a uniformly spaced sequence of pulses at its input.

In this paper pulsed RC networks form the principal components of some basic building blocks in a procedure for synthesizing any physically realizable rational pulsed transfer function (*i.e.*, any physically realizable rational function of  $e^{sT}$ ). Thus, since RC networks are relatively cheap, the use of pulsed RC networks can obtain the same performance as linear digital computers at a significant reduction in cost. This economy is obtained at a sacrifice of the inherent flexibility of digital computers.

Special consideration is given to the use of pulsed RC networks for the compensation of sampled-data feedback control systems. Two numerical examples illustrate the theory.

#### 49.4. An Operational Calculus for Numerical Analysis

SAMUEL THALER AND RUBIN BOXER, *Griffiss Air Force Base, Rome, N. Y.*

A numerical analysis method for solving linear and nonlinear differential equations is related to the Laplace transform techniques. It is shown that approximation formulas obtained from Taylor series expansions in the time domain are equal to the relations obtained by limiting the contour in the complex frequency plane when evaluating the inverse Laplace transform. The theory is an extension of the work reported earlier by the authors in the PROCEEDINGS OF THE IRE.

The operational calculus permits one to obtain the solution of linear and nonlinear systems from the Laplace transforms by a process of simple synthetic division. Examples of linear, time varying, time lag, and nonlinear systems are included together with a discussion of the limitations and the error involved.

#### 49.5. Linear Complementary Smoothing Compensated for Sampled Data Lags

J. L. RYERSON, *Griffiss Air Force Base, Rome, N. Y.*

In general, time functions sampled at regular intervals, damped and smoothed, creates a function which lags in time by approximately one-half the sampling interval. If one of the inputs to a dual input complementary filter is so sampled, as is the case when dealing with radar information passed through a digital

data link, and the other input, such as that from an inertial system, is not sampled, the filter is no longer complementary. The purpose of this paper is to outline a method of introducing a filter modification which will result in the removal of the lag when the sample interval is small relative to the periods of the signals involved.

## SESSION L\*

THURS. 2:30-5:00 P.M.

### WALDORF-ASTORIA EMPIRE ROOM

#### Solid-State Devices

Chairman: JOHN S. SABY,  
*General Electric Co.,  
Syracuse, N. Y.*

#### 50.1. Electrets

E. G. LINDEN, *Signal Corps  
Engineering Labs., Fort  
Monmouth, N. J.*

The theory of formation, dielectric properties and methods of manufacture of electrets are discussed. Electrets are also discussed in relation to charge density, thermal properties, radiation effects, solvent action, mechanical abrasion, and materials of construction. The production of electrical pulses on heating and of special charge configurations by special techniques are described. A simple test for distinguishing between electrets and electrostatically charged bodies is given. The applications of electrets are described to dust filters, microphones, electrometers, humidity indicators, Geiger-Mueller counters, spark transmitters, electrostatic generators, electrostatic memory devices and electrophotography.

#### 50.2. High-Frequency Germanium N-P-N Tetrode

D. W. BAKER, *General Electric  
Co., Syracuse, N. Y.*

A grown junction germanium n-p-n tetrode has been designed and developed for commercial and military applications in production quantities. This device has similar characteristics to the device mentioned in a paper by Wallace, Dickten, and Schimpf (PROC. IRE, Nov. 1952). The contents of this report is concerned with a general description of the techniques of fabrication, evaluation, and application potentialities.

Completed units have power gains in excess of 10 db at 30 mc with a 2 mc bandwidth. Nearly all of these units when not subjected to a 2 mc bandwidth requirement will produce nonoscillating gains from 20-50 db at 30 mc. Peak inverse voltages average 20-30 volts while alpha cutoff frequency varies from 30 to 60 mc. Collector capacity is 4-6 uuf and base resistance is below 800 ohms. Considerable variation in the bias conditions can be imposed on these units with very little reduction in power gain. These tetrodes can be subjected to high emitter currents without any appreciable reduction in alpha. Maximum oscillating frequencies range from 100-200 mc.

\* Sponsored by the Professional Group on Electron Devices. To be published in Part 3 of the IRE Convention Record.

#### 50.3. Power Transistor Design Limitations

MASON CLARK, *Bell Telephone  
Labs., Murray Hill, N. J.*

The design of power transistors for transmission and switching applications is shown to require multiple compromises among the electrical and physical parameters. In particular, the power dissipation requirement is shown to conflict with frequency response or switching speed requirements. The design objectives are stated in the form of gain-power or gain-band-power figures of merit. These are expressed in terms of the device electrical parameters which are, in turn, expressed in terms of the device structural parameters. The structural parameters are then balanced to maximize the circuit performance. The method is applied to a specific set of high-speed power transistor requirements and the design of the transistor is described.

#### 50.4. Investigation of Power Gain and Transistor Parameters as Functions of Both Temperature and Frequency

A. B. GLENN AND I. JOFFE,  
*Radio Corporation of America,  
Camden, N. J.*

In equipments operating under conditions of large changes in ambient temperatures, it is important to know how the performance of such equipment is affected. This is especially true in airborne electronics equipment utilizing transistors since transistors are known to be temperature sensitive. The purpose of this paper is to present the results of an investigation made to determine the effects of both temperature and frequency on the transistor parameters and power gain. These measurements were made on both alloy junction germanium and grown junction silicon transistors over the frequency and temperature ranges of 0.5 to 4.0 megacycles and -55°C to +125°C respectively.

#### 50.5. High Frequency Silicon Tetrode

R. F. STEWART AND W. A. ADCOCK,  
*Texas Instrument Co.,  
Dallas, Texas*

Characteristics of a silicon tetrode are to be discussed. Good power gain at 30 mc has been developed and employed in circuits to be described.

#### 50.6. Semiconductor Capacitance Amplifier

FREDERICK DILL, JR. AND LOUIS  
DEPIAN, *Carnegie Institute of  
Technology, Pittsburgh, Pa.*

A semiconductor junction diode biased in the reverse direction exhibits capacitance properties; this capacitance is dependent upon the inverse square root of the applied reverse voltage. Voltage-dependent capacitances using

barium-strontium bodies have been used in so-called dielectric amplifier circuits to obtain both voltage and power gain. Superior characteristics can be obtained with semiconductor capacitors. A typical amplifier utilizing a large area germanium junction in a conventional dielectric amplifier circuit has yielded a stable voltage gain of over 30. The semiconductor capacitor has better temperature stability and therefore higher stable gains can be realized than in comparable barium-titanate dielectric amplifiers.

## SESSION LI\*

THURS. 2:30-5:00 P.M.

### WALDORF-ASTORIA ASTOR GALLERY

#### Where is Medical Electronics Going?

##### A Symposium in Prediction

Four speakers with experience in widely varied parts of the biophysical, medical, electronic and engineering sciences will compare notes on the present state of the art and will attempt to predict the major directions in which biophysical medical electronics will make future advances.

51.1. V. K. ZWORYKIN, *RCA  
Research Labs., Princeton,  
N. J.*

Medical electronics will provide technical facilities with which life scientists will implement their work.

51.2. C. L. TAYLOR, *University  
of California, Los Angeles,  
Calif.*

Medical electronics will coordinate man and his machines.

51.3. A. C. BURTON, *University  
of Western Ontario, Medical  
School, London, Ontario,  
Canada*

Biophysics and medical electronics will permit understanding of fundamental life processes in terms of sound physics and engineering principles.

51.4. O. E. SCHMITT, *University  
of Minnesota, Minneapolis,  
Minn.*

Biophysics will evolve into a theoretical science based on physics, engineering, biology and medicine but having a set of principles of its own.

\* Sponsored by the Professional Group on Medical Electronics. To be published in Part 9 of the IRE Convention Record.

## SESSION LII\*

THURS. 2:30-5:00 P.M.  
WALDORF-ASTORIA  
JADE ROOM

## Component Parts II

Chairman: C. G. WALANCE,  
*Hughes Aircraft Corp.,  
Culver City, Calif.*

52.1. Preparation of Standards  
and Test Procedures for  
Printed Circuits

E. R. GAMSON and A. HANESIAN,  
*Stanford Research Inst.,  
Menlo Park, Calif.*

The printed circuit has gained the maturity of production acceptance in almost every area of electronic equipment manufacture. This wide usage has accelerated the need for standardization and adequate test procedures for materials and the final products. With the transition from laboratory development of quantity production, the necessity for increased quality control to insure a reliable product has become a prime requisite.

The Air Force has recognized the importance of a definitive study on performance parameters of printed circuits together with an evaluation of the related materials and processes. Therefore, under Air Force sponsorship a research program has been initiated at Stanford Research Institute to investigate and develop specifications and standards. Since the ultimate success of this study will also depend upon the acceptance and cooperation of industry, this paper is, in essence, a progress report which indicates the approach to the problem together with some results to date.

52.2. New Ceramic Feedthrough  
Capacitors with Tremendous  
Increase in Effective  
"Capacitance"

H. M. SCHLICKE, *Allen Bradley  
Co., Milwaukee, Wis.*

Feedthrough capacitors built of a multiplicity of stacked discs with center holes are practically useless filter elements because they behave like tubular feedthrough capacitors, only worse.

If, however, washers of suitable lossy ferrite are inter-spaced in the structure, the effective coupling impedance, for the lower frequencies is identical with the total capacitance, whereas, at medium and higher frequencies, the effective coupling impedance is reduced by a factor of 1,000 to 10,000, or more, as compared with the best discoidal feedthrough capacitors available now. In fact, the effective coupling impedance is so low that resonances of the discs (even large ones) themselves become negligible.

The mathematical theory for all cases above is developed by matrix algebra and verified by experiments.

\* Sponsored by the Professional Group on Component Parts. To be published in Part 6 of the IRE Convention Record.

The practical significance of this development for extremely effective miniaturized low pass filters is presented.

52.3. Performance of Continuous  
and Discontinuous Tube Feed-  
through Capacitors at VHF  
and Higher Frequencies

E. M. WILLIAMS, *Carnegie Institute  
of Technology, Pittsburgh, Pa.*, AND  
J. H. FOSTER, *Erie Resistor  
Corp., Erie, Pa.*

Tubular capacitors are known to have inferior insertion loss characteristics as feedthrough filters in the upper vhf range as a result of distributed parameter circuit resonances. It is shown that these resonances are offset in the upper vhf range by high-losses in the ceramic material. Insertion loss characteristics can, moreover, be improved throughout the vhf range by the introduction of one or more discontinuities in the ceramic tube; simple units of this type have better filter performance at the higher frequencies than discoidal units of equal capacitance.

52.4. Piezoelectric Ceramic IF  
Band-Pass Filters

O. E. MATTIAT, *Clevite Research  
Center, Cleveland, Ohio*

Piezoelectric ceramic resonators are employed as circuit elements to form ladder type band-pass filter sections in the 455 kc IF frequency range. The limitations on the design of such sections imposed by the electromechanical characteristics of ceramic resonators are discussed. Three different ceramic compositions have been employed to make band pass filters. Besides using piezoelectric ceramic resonators in otherwise conventionally designed crystal filters such resonators can be used in a great variety of other forms by application of special electrode arrangements, special polarizing field, etc. Some of these novel configurations will also be discussed.

52.5. Tantalum Solid Electro-  
lytic Capacitors

D. A. MCLEAN AND F. S. POWER,  
*Bell Telephone Labs.,  
Murray Hill, N. J.*

The feature of a new type of tantalum electrolytic capacitor developed by Bell Telephone Laboratories is replacement of the usual aqueous electrolyte with a semiconductor, MnO<sub>2</sub>. This results in a capacitor made entirely of solid, stable, nonvolatile inorganic materials. The new capacitors are characterized by excellent low-temperature properties and superior frequency characteristics. Because of absence of hermetic seal and because of minimizing the volume occupied by electrolyte, these capacitors are extremely small in size. They have indefinitely long shelf life, even at elevated temperature. While experience with them is still limited, they appear to be highly reliable. These capacitors will be manufactured by the Western Electric Co. for Bell System uses and will find their initial application in a

new carrier telephone system. They are expected to find extensive use in both civilian and military equipment.

## SESSION LIII\*

THURS. 2:30-5:00 P.M.

WALDORF-ASTORIA  
SERT ROOM

## Information Theory III

Chairman: MICHAEL J. DI TORO,  
*Polytechnic Res. & Dev. Co.,  
Inc., Brooklyn, N. Y.*

53.1. A Prediction Theory Ap-  
proach to Information Rates

K. H. POWERS, *M.I.T.,  
Cambridge, Mass.*

Regarding a change of probability measure to be the fundamental information process, a unified definition for the amount of information resulting is introduced. This definition is sufficiently general to include as special cases both discrete and continuous theories. With the recognition of an intimate relationship between information theory and the prediction theory of Kolmogorov and Wiener, the techniques of linear prediction are employed to determine the rate at which one gaussian time function gives information about the past, present, and/or future of another similar function correlated with it. The results of this study are applied to the investigation of the processes by which information is lost in additive noisy channels as well as in linear filters and predictors.

53.2. Reduced-Alphabet Repre-  
sentation of Television Signals

E. R. KRETZMER, *Bell Telephone  
Labs., Inc., Murray Hill, N. J.*

Experimental results are presented, in the form of kinescope photographs, showing the performance of a scheme for reducing the alphabet required for the discrete representation of television signals. The reduction is obtained by unusually coarse amplitude quantization of the high-frequency components of the signal, the low-frequency components being rendered with customary accuracy. The experiments reported on are of an exploratory nature and pertain to a system requiring about half as much channel capacity as that needed with the conventional discrete representation. The resulting picture degradation is of an unusual nature and is surprisingly small for many types of picture material.

53.3. A Bit-Squeezing Technique  
Applied to Speech Signals

E. E. DAVID, JR., AND H. S.  
MCDONALD, *Bell Telephone  
Labs., Murray Hill, N. J.*

\* Sponsored by the Professional Group on Information Theory. To be published in Part 4 of the IRE Convention Record.

This paper discusses conservation of channel capacity by sampling and quantizing the signal to be transmitted after separating it into two or more frequency bands. Applications to speech have been investigated. Such coding takes advantage of two characteristics of speech systems; namely the signal (power) spectrum shape, and the ear's greater tolerance for errors at some frequencies than at others. When carried to the "many band" limit, it functions to the same extent as an ideal code, considering spectrum shape only. An rms fidelity criterion is used. A system utilizing two bands has been tested and the output rated by subjective tests.

### 53.4. Communication Through Noisy, Random-Multipath Channels

G. L. TURIN, *M.I.T., Cambridge, Mass.*

Statistical methods are applied in this paper to the problem of communication through a channel which consists of a discrete multipath ionosphere with random path strengths and delays, with random noise added at the receiver end.

The transmitter of a system for use with such a channel is specified as one which transmits selections from a finite set of message waveforms; these waveforms are assumed to be known to the receiver. It is postulated that the receiver contains a Woodward-Davies probability computer, and the operational form of this computer is determined under various assumptions concerning the amount of statistical information about the channel which is available to the receiver. An expression for the probability of error for a receiver which chooses the *a posteriori* most probable message waveform is established, and is evaluated in a special case. Finally, the problem of the determination of an optimum set of message waveforms is considered, again for a special case.

### 53.5. Multipath Distortion of TV Signals and the Design of a Corrective Filter

A. V. BALAKRISHNAN, *Radio Corporation of America, Camden, N. J.*

In the transmission of information by electromagnetic waves a source of possible distortion is the presence of multipath interference. In the present paper, the multipath distortion of tv video signals is studied using the methods of statistical communication theory. The multipath is assumed to arise from a finite number of specular reflections.

The measure of distortion adopted is based on the normalized cross-correlation between the transmitted and received signals and is closely related to the mean square error between them. Both amplitude and frequency modulated systems are examined and the distortion before and after demodulation is evaluated.

The problem of designing a linear passive filter that minimizes the distortion due to multipath is considered and is shown to have a physically realizable solution. The optimal filter transfer function is derived and the reduction in distortion possible is evaluated.

## SESSION LIV\*

THURS. 2:30-5:00 P.M.

### KINGSBRIDGE ARMORY MARCONI HALL

#### Microwave Instrumentation

*Chairman:* EUGENE G. FUBINI,  
*Airborne Instruments Lab., Inc., Mineola, N. Y.*

#### 54.1. An Amplitude Regulator for Microwave Signal Sources

P. FIRE AND P. H. VARTANIAN,  
*Sylvania Electric Products Inc., Mountain View, Calif.*

An electronically controllable microwave attenuator utilizing the zero field loss characteristics of ferrites has been developed to regulate the output of a microwave source to a small variation over a 2 to 1 frequency range. Models of the regulator reduced a 14 db signal generator variation to a 0.7 db variation over the 1.8 to 4 kmc band with similar control in the 4.0 to 7.6 kmc band. The attenuator consists of a ferrite sleeve mounted in a coaxial line and transversely magnetized by a small electromagnet. It is contained in a two inch cube and weighs less than 12 ounces. The insertion loss of this element is varied by the output power level, through a negative feedback loop, so as to maintain relatively constant power at the attenuator output.

#### 54.2. Measurement of the Complex Dielectric Constant of Materials from 100 to 1200 Megacycles Over a Wide Range of Temperature

ISIDORE BADY, *Signal Corps Engineering Labs., Fort Monmouth, N. J.*

A simple yet accurate method for the measurement of the complex dielectric constant is described. The sample holder consists of a section of coaxial transmission line which may be closed either at both ends or at one end only. The real part of the dielectric constant is determined by measuring the resonant frequencies of the sample holder, both with the sample in and empty. The dissipation factor is determined by the application of the frequency variation technique. Careful consideration is given to all possible sources of error, which include effect of the input and output loops, wall losses, and fringing fields. The sample holder is very convenient for measurements over a wide range of temperature, as any commercial variable temperature cabinet can be used.

#### 54.3. The Z Scope—An Automatic Impedance Plotter for Microwaves

\* Sponsored jointly by the Professional Groups on Instrumentation and on Microwave Theory and Techniques. To be published in Part 5 of the IRE Convention Record.

J. P. VINDING, *Cascade Research Corp., Los Gatos, Calif.*

This paper presents a new microwave test instrument which will automatically show the impedance of a waveguide component as a light spot on a Smith chart mounted over the face of a cathode ray tube.

The use of modern ferrite modulators has enabled the application of a simple principle which is very well suited for a wide frequency range so that one instrument will cover a whole waveguide band without tuning or manual adjustments.

The theory is given in detail and several points in the practical realization are described. Among these the built-in microwave agc system is of considerable interest also for other applications.

Some typical curves of impedance vs frequency as seen on the instrument will be shown.

#### 54.4. A Swept, Broad-Band, Microwave, Double Detection System with Automatic Synchronization

D. L. FAVIN, *Bell Telephone Labs., Inc., Murray Hill, N. J.*

A double detection system has been developed for use in the 4 kmc common carrier band. Two microwave sweep frequency oscillators are automatically synchronized and made to track so as to produce an IF of 70 mc  $\pm$  4 mc for 500 mc sweep width. This synchronization is maintained with as much as an 87 db path loss and in the presence of selective deep fades. After termination of a complete band fade, synchronization is automatically re-established. The source (transmitter) oscillator may be located remote from the local (receiver) oscillator without need for order wire or similar facilities since synchronization is accomplished by using only the information present in the transmitted signal.

#### 54.5. Coaxial Components Employing Gaseous Discharges at Microwave Frequencies

R. H. GEIGER AND P. E. DORNEY,  
*Roger White Electron Devices, Inc., Ramsey, N. J.*

The concept of using a gas discharge plasma at microwave frequencies is discussed. A brief review of presently available gas discharge components in waveguide is presented. Similar devices which have been developed in coaxial line geometries are described. Particular emphasis is placed on gas attenuators and noise sources. Detailed physical descriptions are given of both classes of devices. Significant dc and rf performance characteristics are described. Special attention is given to systems applications for such noise sources and attenuators. Their use as modulators, control tubes, and protective devices is described in detail.

#### 54.6. High Power Breakdown of Microwave Structures

F. R. STEVENSON, M. S. TANENBAUM AND G. K. HART,  
*Sperry Gyroscope Co., Great Neck, N. Y.*

A test circuit for measuring peak power capacity of waveguide structures is presented. The problems and probable accuracies in the test procedure are discussed. Data is presented on the power carrying capacity of several basic waveguide structures including irises, posts, bends, and steps. The effect of vswr and geometric parameters are included.

## SESSION LV\*

THURS. 2:30-5:00 P.M.

### KINGSBRIDGE ARMORY FARADAY HALL

#### Broadcast Transmission Systems— New Horizons

Chairman: **RAYMOND F. GUY**,  
*National Broadcasting Co.,  
New York, N. Y.*

#### 55.1. The Technical Boundary Conditions of Subscription Television

**ALEXANDER ELLETT AND ROBERT  
ADLER**, *Zenith Radio Corp.,  
Chicago, Ill.*

Subscription television presents some highly interesting technical problems. An elementary question is how much scrambling will be needed; a public test produced surprising answers.

Several effective picture scrambling methods use rapid switching between different modes of presentation. Not all these methods fit together with conventional receivers; video linearity, properties of sweep circuits, etc. restrict the choice.

Methods for sending the information needed by the subscriber are discussed, including one where multi-digit code pulses are transmitted openly. Security of subscription systems,

\* Sponsored by the Professional Group on Broadcast Transmission Systems. To be published in Part 7 of the IRE Convention Record.

a concept very different from military security, is defined and several proposed systems are compared in this respect.

#### 55.2. An Integrated System of Coded Picture Transmission

**E. M. ROSCHKE, W. S. DRUZ, CARL  
EILERS, AND JAN PULLES**,  
*Zenith Radio Corp.,  
Chicago, Ill.*

This paper discusses a specific method of scrambling and code transmission and reviews its security. An electronic switching arrangement is described which, under control of a square wave, produces and resolves the scrambled pattern.

Locking and phasing of this square wave is accomplished by directing several pulses to selected input points in a countdown chain. These pulses are transmitted as part of the video signal and no other connection between transmitter and receiver is required.

It is shown how such a system can be rendered secure by the combination of redundant codes and permutation devices.

#### 55.3. Chromaticity Coordinate- Plotter Photometer

**W. H. HIGHLEYMAN, M.I.T., Cam-  
bridge, Mass., M. J. CANTELLA, USS  
Valley Forge, c/o Fleet Post Office,  
New York, N. Y., AND V. A. BABITS,  
Rensselaer Polytechnic Inst.,  
Troy, N. Y.**

An instrument which will respond to a colored light source and will compute and plot the chromaticity coordinates of the color on the screen of a cathode ray tube, is described.

The instrument consists of three parts. The first part is the known Sziklai tristimulus photometer. The second part is an analog computer which determines the chromaticity of the plotter. The third part of the instrument plots the computed coordinates on an oscilloscope screen.

The analysis of the instrument system and the response characteristics will be discussed from the viewpoint of high frequency response.

#### 55.4. Recent Improvements in Black-and-White Film Re- cording for Color Television Use

**W. L. HUGHES**, *Iowa State College,  
Ames, Iowa.*

In three previous papers on this subject, a particular system for recording color television images on black-and-white film was proposed and experimental equipment was described. Certain problems which were concerned with image definition were yet to be resolved in the reproducing device. These definition problems arose from conflicting demands which were imposed on the scanner tube and the optical system. The problems have been resolved by extensive changes in scanner tube and optical system characteristics such that definition capabilities of the system are now well beyond the capabilities of the standard television transmission system. These changes will be described along with some improvements in the film transport mechanism. Several color photographs of pictures from a dichroic display will be shown.

#### 55.5. Design Considerations for a High Quality Transistorized Program Amplifier for Remote Broadcast Use

**J. K. BIRCH**, *Gates Radio Co.,  
Quincy, Ill.*

Small size and extremely low battery drain make transistors attractive for use in portable broadcast equipment. However, they present many unique problems which must be overcome. Variation of certain parameters with temperature necessitates stabilization of biases for reliable operation at any temperature.

Narrow dynamic range of the transistor is a serious obstacle to development of amplifiers for microphone use, and it must be improved by special circuit techniques. Requirements of wide frequency response and low distortion for broadcast service call for high quality miniature transformers not generally available.

A transistorized program amplifier has been built utilizing the principles outlined, and is commercially available in several forms. It illustrates the practicability of transistorized portable equipment.



# IRE News and Radio Notes

## Calendar of Coming Events

Conference on Radio Interference Reduction by Armour Research Foundation, Chicago, Ill., Mar. 6-7

IRE National Convention and Radio Engineering Show, Waldorf-Astoria Hotel and Kingsbridge Armory, New York City, Mar. 19-22

Symposium on the Application of Ferrite Devices to Microwaves, Harvard Univ., Cambridge, Mass., Apr. 2-4

PGIE-AIEE-ISA Conference on Magnetic Amplifiers, Syracuse, N. Y., Apr. 5-6

Seventh Regional Technical Conference and Trade Show, Hotel Utah, Salt Lake City, Utah, Apr. 11-13

Tenth Annual Spring Television Conference of the Cincinnati Section, Engineering Society of Cincinnati Building, Cincinnati, Ohio, Apr. 13-14

International Electronics Show of the El Paso Section, El Paso Coliseum, El Paso, Tex., Apr. 13-15

National Industrial Research Conference, Hotel Sherman, Chicago, Ill., Apr. 18-19

New England Radio Engineering Meeting, Sheraton Plaza Hotel, Boston, Mass., Apr. 23-24

PGCT-PIB Symposium on Non-linear Network Theory, Engineering Society Building, New York City, Apr. 25-27

Fourth Annual Semiconductor Symposium of Electrochemical Society, Mark Hopkins Hotel, San Francisco, Calif., Apr. 29-May 3

URSI Spring Meeting, National Bureau of Standards, Washington, D. C., Apr. 30-May 3

IRE-RETMA-AIEE-WCEMA Electronic Components Symposium, U. S. Department of Interior, Washington, D. C., May 1-3

National Aeronautical and Navigational Conference, Hotel Biltmore, Dayton, Ohio, May 14-16

Symposium on Reliable Applications of Electron Tubes, University of Pennsylvania, Philadelphia, Pa., May 22-23

## BOSTON SECTION INAUGURATES TRANSISTOR LECTURE SERIES

The Boston Section will conduct a Transistor Lecture Series of eight lectures on consecutive Wednesday evenings, March 28 through May 16. Lecture Series Chairman is W. R. Thurston. The registration fee for the entire series is \$6.00 for members or students and \$9.00 for non-members. The fee for either Part I or Part II only is \$4.00 for members or students and \$6.00 for non-members. A large attendance is expected, and registration cards will be distributed on a first come, first served basis until the capacity of the lecture hall is reached. For further information contact the IRE Boston Section Office, 73 Tremont Street, Boston, Massachusetts.

The lecture series will be divided into two parts. The first part will be devoted to the transistor as a device. R. H. Kingston of Lincoln Laboratory, Massachusetts Institute of Technology, will deliver a lecture entitled *Physical Nature of Semiconductors* on March 28 and April 5. *Properties of Junction Transistors* will be the subject of a lecture by F. H. Blecher and R. H. Mattson of Bell Telephone Laboratories on April 12 and 19. The second part of the lecture series, devoted to transistor circuit theory, will open with two lectures by R. M. Cohen of RCA. He will discuss *Audio Applications of Transistors* and *High Frequency Operation of Transistors* on April 26 and May 2. J. C. Logue of International Business Machines will speak on *Switching Circuit Applications of Junction Transistors* and *Transistors in Building-Block Circuits* on May 9 and 16.

## FORT WORTH SECTION APPROVED

On January 5, the IRE Board of Directors approved the establishment of the Fort Worth Section. At the same time, the name of the Dallas-Fort Worth Section was changed to the Dallas Section.

## ARMOUR RESEARCH FOUNDATION SPONSORS FIRST INDUSTRIAL RESEARCH CONFERENCE

Industrial research, its motives, its management, and its results, will undergo examination at the first annual National Industrial Research Conference sponsored by Armour Research Foundation of Illinois Institute of Technology, which will be held April 18 and 19 at Hotel Sherman, Chicago, Ill.

The purpose of the conference is to provide a forum where common problems of industrial research can be discussed at a management level. "Research for Profit" has been selected as the theme for the two-day conference which will be open to all industrial executives interested in the management of research and development.

Twelve papers will be presented at three half-day sessions, two luncheon meetings, and a dinner meeting at Hotel Sherman. Included among the luncheon addresses will be a talk by a government official on industry's stake in defense spending.

The opening day's morning session will deal with the record of profitable research and will include addresses by representatives of a large corporation, a medium-sized company, and a trade association. Research management discussions will be covered in the afternoon session, with papers on the value of basic research, the use of outside research facilities, and a review of results.

A session showing how the typical stockholder, company, and researcher regard research will be held on the morning of April 19. Special tours of Armour Research Foundation, if desired, will be conducted. Exhibits will be on display at Hotel Sherman.

Further information about the conference can be obtained by writing to J. J. Kowal, Conference Secretary, Armour Research Foundation of Illinois Institute of Technology, 10 West 35th Street, Chicago 16, Ill.

## Third Annual Joint Fall Meeting



At the joint session of the Buffalo-Niagara and Hamilton Sections, D. E. Mullen, General Electric Co., gave an address entitled "Guided Missiles Are Smarter Than People." Shown at the meeting are (left to right): W. Holmes, Secretary, Buffalo-Niagara Section; G. Beaumont, Chairman of the Hamilton Section; D. E. Mullen; D. P. Welch, Chairman of the Buffalo-Niagara Section; A. Tromanger, Vice-Chairman of the Hamilton Section; and N. Chapman, Secretary of the Hamilton Section. This year's joint session was at Niagara Falls, New York.

## TRANSACTIONS OF THE IRE PROFESSIONAL GROUPS

The following issues of TRANSACTIONS are available from the Institute of Radio Engineers, Inc., 1 East 79 Street, New York 21, N. Y., at the prices listed below:

Sponsoring Group	Publications	Group Mem- bers	IRE Mem- bers	Non- Mem- bers*
Aeronautical and Navigational Electronics	PGAE-5: A Dynamic Aircraft Simulator for Study of Human Response Characteristics (6 pages)	\$0.30	\$0.45	\$0.90
	PGAE-6: Ground-to-Air Cochannel, Interference at 2900 MC (10 pages)	.30	.45	.90
	PGAE-8: June 1953 (23 pages)	.65	.95	1.95
	PGAE-9: September 1953 (27 pages)	.70	1.05	2.10
	Vol. ANE-1, No. 2, June 1954 (22 pages)	.95	1.40	2.85
	Vol. ANE-1, No. 3, September 1954 (27 pages)	1.00	1.50	3.00
	Vol. ANE-1, No. 4, December 1954 (27 pages)	1.00	1.50	3.00
	Vol. ANE-2, No. 1, March 1955 (41 pages)	1.40	2.10	4.20
	Vol. ANE-2, No. 2, June 1955 (49 pages)	1.55	2.30	4.65
	Vol. ANE-2, No. 3, September 1955 (27 pages)	.95	1.45	2.85
Antennas and Propagation	PGAP-4: IRE Western Convention, August 1952 (136 pages)	2.20	3.30	6.60
	Vol. AP-1, No. 1, July 1953 (30 pages)	1.20	1.80	3.60
	Vol. AP-1, No. 2, October 1953 (31 pages)	1.20	1.80	3.60
	Vol. AP-2, No. 1, January 1954 (39 pages)	1.35	2.00	4.05
	Vol. AP-2, No. 2, April 1954 (41 pages)	2.00	3.00	6.00
	Vol. AP-2, No. 3, July 1954 (36 pages)	1.50	2.25	4.50
	Vol. AP-3, No. 4, October 1954 (36 pages)	1.50	2.25	4.50
	Vol. AP-3, No. 1, January 1955 (43 pages)	1.60	2.40	4.80
	Vol. AP-3, No. 2, April 1955 (47 pages)	1.60	2.40	4.80
	Vol. AP-3, No. 3, July 1955 (66 pages)	2.05	3.10	6.15
Audio	PGA-7: Editorials, Technical Papers & News, May 1952 (47 pages)	.90	1.35	2.70
	PGA-10: November-December 1952 (27 pages)	.70	1.05	2.10
	Vol. AU-1, No. 1, January-February 1953 (24 pages)	.60	.90	1.80
	Vol. AU-1, No. 2, March-April 1953 (34 pages)	.80	1.20	2.40
	Vol. AU-1, No. 3, May-June 1953 (34 pages)	.80	1.20	2.40
	Vol. AU-1, No. 5, September-October 1953 (11 pages)	.50	.75	1.50
	Vol. AU-1, No. 6, November-December 1953 (27 pages)	.90	1.35	2.70
	Vol. AU-2, No. 1, January-February 1954 (38 pages)	1.20	1.80	3.60
	Vol. AU-2, No. 2, March-April 1954 (31 pages)	.95	1.40	2.85
	Vol. AU-2, No. 3, May-June 1954 (27 pages)	.95	1.40	2.85
	Vol. AU-2, No. 4, July-August 1954 (27 pages)	.95	1.40	2.85
	Vol. AU-2, No. 5, September-October 1954 (22 pages)	.95	1.40	2.85
	Vol. AU-2, No. 6, November-December 1954 (24 pages)	.80	1.20	2.40
	Vol. AU-3, No. 1, January-February 1955 (20 pages)	.60	.90	1.80
	Vol. AU-3, No. 2, March-April 1955 (32 pages)	.95	1.40	2.85
Vol. AU-3, No. 3, May-June 1955 (30 pages)	.85	1.25	2.55	
Vol. AU-3, No. 4, July-August 1955 (46 pages)	1.15	1.75	3.45	
Vol. AU-3, No. 5, September-October 1955 (33 pages)	.90	1.35	2.70	
Vol. AU-3, No. 6, November-December 1955 (36 pages)	.95	1.40	2.85	
Broadcast Transmission Systems	PGBTS-1: March 1955 (102 pages)	2.50	3.75	7.50
	PGBTS-2: December 1955 (54 pages)	1.20	1.80	3.60
	PGBTS-3: January 1956 (86 pages)	2.10	3.15	6.30
Broadcast and Television Receivers	PGBTR-1: Round-Table Discussion on UHF TV Receiver Considerations, 1952 IRE National Conventions (12 pages)	.50	.75	1.50
	PGBTR-5: January 1954 (96 pages)	1.80	2.70	5.40
	PGBTR-6: April 1954 (119 pages)	2.35	3.50	7.00
	PGBTR-7: July 1954 (58 pages)	1.15	1.70	3.45
	PGBTR-8: October 1954 (20 pages)	.90	1.35	2.70
	Vol. BTR-1, No. 1, January 1955—Papers Presented at the Radio Fall Meeting, 1954 (68 pages)	1.25	1.85	3.75
	Vol. BTR-1, No. 2, April 1955 (40 pages)	.95	1.45	2.85
	Vol. BTR-1, No. 3, July 1955 (51 pages)	.95	1.45	2.85
Vol. BTR-1, No. 4, October 1955 (19 pages)	.95	1.40	2.85	
Circuit Theory	Vol. CT-1, No. 1, March 1954 (80 pages)	1.30	1.95	3.90
	Vol. CT-1, No. 2, June 1954 (39 pages)	1.00	1.50	3.00
	Vol. CT-1, No. 3, September 1954 (73 pages)	1.00	1.50	3.00
	Vol. CT-1, No. 4, December 1954 (42 pages)	1.00	1.50	3.00

\* Public libraries, colleges and subscription agencies may purchase at IRE member rate.

(Continued on page 420)

WESCON PAPERS DEADLINE  
SET FOR APRIL 15

Authors wishing to present papers at the 1956 WESCON Convention, to be held at Los Angeles on August 21-24, should send abstracts of their papers by April 15 to the alternate chairman, W. H. Ware, The Rand Corp., 1700 Main Street, Santa Monica, Calif., for evaluation by the technical program committee.

Authors will be notified whether or not their papers are accepted by May 15. Authors of accepted papers will be expected to submit a complete manuscript by July 1 so that preprints may be distributed at the meeting.

## FERRITE SYMPOSIUM AT HARVARD

A Symposium on Microwave Properties and Applications of Ferrites will be held April 2-4 at Harvard University, Cambridge, Massachusetts. It will be sponsored by Harvard University, the Air Force Cambridge Research Center, and the Professional Group on Microwave Theory and Techniques. For further information, write to Professor C. L. Hogan, Pierce Hall, Harvard University, Cambridge 38, Massachusetts. Advance registration by mail is required.

TECHNICAL PANEL NAMED ON  
EARTH SATELLITE PROGRAM

Joseph Kaplan, Chairman of the U. S. National Committee for the International Geophysical Year, has announced the formation of the Technical Panel on the Earth Satellite Program. Members of the panel include R. W. Porter, Chairman, General Electric Company; Hugh Odishaw, Secretary, National Academy of Sciences; Joseph Kaplan, UCLA; H. E. Newell, Jr., Naval Research Laboratory; W. H. Pickering, California Institute of Technology; A. F. Spilhaus, University of Minnesota; Lyman Spitzer, Jr., Princeton University; J. A. Van Allen, State University of Iowa; and F. L. Whipple, Smithsonian Astrophysical Observatory and Harvard University.

The panel will have fundamental responsibility for the development, coordination and direction of the over-all scientific satellite effort, part of the U. S. program during the International Geophysical Year.

PAPERS SOLICITED FOR  
NUCLEAR SCIENCE MEETING

The Third Annual Meeting of the Professional Group on Nuclear Science will take place at Mellon Institute Auditorium, Pittsburgh, Pennsylvania, September 20-21, 1956. Persons wishing to submit papers on reactor instrumentation, reactor control systems, stability analysis, analog simulation and digital computation should send their contributions to W. P. Caywood, Chairman of the Papers Committee, Box 8656, Pittsburgh 21, Pennsylvania, before June 15, 1956.

### M.I.T. ESTABLISHES SCHOOL FOR ADVANCED STUDY

Establishment of a School for Advanced Study at Massachusetts Institute of Technology was announced recently by President James R. Killian, Jr.

The new school will provide means by which post-doctoral scholars from all over the world can join with the M.I.T. faculty in high-level theoretical studies and research. M. J. Buerger, professor of mineralogy and crystallography, has been appointed director.

The school will be similar in its objectives to the Institute for Advanced Studies at Princeton (where Albert Einstein spent the latter years of his life) but the Princeton center has a permanent staff of some size.

Unlike the Princeton School, the M.I.T. School for Advanced Study will be an integral part of the Institute, and constitute an extension of the level of the programs of the undergraduate and graduate schools. These three schools will constitute the "horizontal" schools of M.I.T. Professors participating in its activities will remain on the faculties of the five "vertical" schools of Science, Engineering, Architecture and Planning, Industrial Management, and Humanities and Social Studies. Its special staff, to begin with, will consist only of the director and a secretary.

Dr. Buerger, who will assume the office of director July 1, has been at the Institute since 1920, when he came as a student. He has been on the staff since 1925 when he was appointed a teaching fellow. He became a full professor in the Department of Geology in 1944 and is now chairman of the M.I.T. faculty.

### G. J. STRICKROTH IS HONORED BY AERONAUTICAL INSTITUTE

The Institute of the Aeronautical Sciences named G. J. Strickroth, Manager of the Electronics Department of the Glenn L. Martin Company, Baltimore, as winner of the Lawrence Sperry Award for 1955.

The Sperry Award is given annually to young men who have made outstanding contributions to aeronautics.

He was cited for "contributions to the development of the guidance system for the Martin Matador, the first and only tactical ground-to-ground missile to be put into operational use by the U. S. Air Force."

The award certificate and an honorarium of \$250 was presented to Mr. Strickroth January 23, at the Institute's annual Honors Night Dinner in the Sheraton-Astor Hotel, New York City, part of the four-day annual meeting of the I.A.S.

The Sperry Award Committee gave Mr. Strickroth major credit for development of the tactical guidance system of the TM-61 Matador, which is actually a small, fast airplane with a guidance system instead of a pilot. He served on the Matador project from 1946 to 1952, and was in charge of guidance system work from 1950 to 1952.

Mr. Strickroth obtained the electrical engineering degree from Catholic University of America in 1943. He joined the Glenn L. Martin Company three years later. He is a Senior Member of the IRE.

## TRANSACTIONS OF THE IRE PROFESSIONAL GROUPS

(Continued)

Sponsoring Group	Publications	Group Mem- bers	IRE Mem- bers	Non- Mem- bers*
	Vol. CT-1, No. 2, March 1955 (106 pages)	\$2.70	\$4.05	\$8.10
	Vol. CT-2, No. 2, June 1955 (113 pages)	2.60	3.90	7.80
	Vol. CT-2, No. 3, September 1955 (62 pages)	1.40	2.10	4.20
Communications Systems	Vol. CS-2, No. 1, January 1954 (83 pages)	1.65	2.50	4.95
	Vol. CS-2, No. 2, July 1954 (132 pages)	2.25	3.35	6.75
	Vol. CS-2, No. 3, November 1954—IRE Symposium on Global Communications, June 23-25, 1954, Washington, D. C. and IRE-AIEE Symposium on Military Communications, April 28, 1954, New York, N. Y. (181 pages)	3.00	4.50	9.00
	Vol. CS-3, No. 1, March 1955—Papers Presented at the Symposium on Marine Communications & Navigation, October 13-15, 1954, Boston, Mass. (72 pages)	1.00	1.50	3.00
Component Parts	PGCP-1: March 1954 (46 pages)	1.20	1.80	3.60
	PGCP-2: September 1954—Papers Presented at the Component Parts Sessions at the 1954 Western Electronic Show & Convention, Los Angeles, Calif. (118 pages)	2.25	3.35	6.75
	PGCP-3: April 1955 (44 pages)	1.00	1.50	3.00
	PGCP-4: November 1955 (92 pages)	2.00	3.00	6.00
Electronic Computers	Vol. EC-2, No. 2, June 1953 (27 pages)	.90	1.35	2.70
	Vol. EC-3, No. 3, September 1954 (54 pages)	1.80	2.70	5.40
	Vol. EC-3, No. 4, December 1954 (46 pages)	1.10	1.65	3.30
	Vol. EC-4, No. 2, June 1955 (36 pages)	.90	1.35	2.70
	Vol. EC-4, No. 3, September 1955 (45 pages)	1.00	1.50	3.00
Electron Devices	PGED-4: December 1953 (62 pages)	1.30	1.95	3.90
	Vol. ED-1, No. 2, April 1954 (75 pages)	1.40	2.10	4.20
	Vol. ED-1, No. 3, August 1954 (77 pages)	1.40	2.10	4.20
	Vol. ED-1, No. 4, December 1954 (280 pages)	3.20	4.80	9.60
	Vol. ED-2, No. 2, April 1955 (53 pages)	2.10	3.15	6.30
	Vol. ED-2, No. 3, July 1955 (27 pages)	1.10	1.65	3.30
	Vol. ED-2, No. 4, October 1955 (42 pages)	1.50	2.25	4.50
Engineering Management	PGEM-1: February 1954 (55 pages)	1.15	1.70	3.45
	PGEM-2: November 1954 (67 pages)	1.30	1.95	3.90
	PGEM-3: March 1955 (52 pages)	1.00	1.50	3.00
Industrial Electronics	PGIE-1: August 1953 (40 pages)	1.00	1.50	3.00
	PGIE-2: March 1955 (81 pages)	1.90	2.85	5.70
Information Theory	PGIT-3: March 1954 (159 pages)	2.60	3.90	7.80
	PGIT-4: September 1954 (234 pages)	3.35	5.00	10.00
	Vol. IT-1, No. 1, March 1955 (76 pages)	2.40	3.60	7.20
	Vol. IT-1, No. 2, September 1955 (50 pages)	1.90	2.85	5.70
Instrumentation	PGI-3: April 1954 (55 pages)	1.05	1.55	3.15
	PGI-4: October 1955 (182 pages)	2.70	4.05	8.10
Medical Electronics	PGME-2: October 1955—Panel Discussion on Medical Electronics (39 pages)	.85	1.25	2.55
	PGME-3: November 1955—Conference on Plethysmography, Held December 10-11, 1953 in Buffalo, N. Y. (55 pages)	1.10	1.65	3.30
Microwave Theory and Techniques	Vol. MTT-1, No. 2, November 1953 (44 pages)	.90	1.35	2.70
	Vol. MTT-2, No. 2, July 1954 (67 pages)	1.25	1.85	3.75
	Vol. MTT-2, No. 3, September 1954 (54 pages)	1.10	1.65	3.30
	Vol. MTT-3, No. 1, January 1955 (47 pages)	1.50	2.25	4.50
	Vol. MTT-3, No. 3, April 1954 (44 pages)	1.40	2.10	4.20
	Vol. MTT-3, No. 4, July 1955 (54 pages)	1.60	2.40	4.80
	Vol. MTT-3, No. 5, October 1955 (59 pages)	1.70	2.55	5.10
Vol. MTT-3, No. 6, December 1955 (64 pages)	1.75	2.60	5.25	
Nuclear Science	Vol. NS-1, No. 1, September 1954 (42 pages)	.70	1.00	2.00
	Vol. NS-2, No. 1, June 1955 (15 pages)	.55	.85	1.65
Reliability and Quality Control	PGQC-2: March 1953 (51 pages)	1.30	1.95	3.90
	PGQC-3: February 1954 (39 pages)	1.15	1.70	3.45
	PGQC-4: December 1954 (56 pages)	1.20	1.80	3.60
	PGRQC-5: April 1955 (56 pages)	1.15	1.75	3.45

\* Public libraries, colleges, and subscription agencies may purchase at IRE member rate.

(Continued on page 421)



TRANSACTIONS OF THE IRE PROFESSIONAL GROUPS

(Continued)

Sponsoring Group	Publications	Group Mem- bers	IRE Mem- bers	Non- Mem- bers*
Telemetry and Remote Control	PGRTRC-1: August 1954 (16 pages)	\$0.85	\$1.25	\$2.55
	PGRTRC-2: November 1954 (24 pages)	.95	1.40	2.85
	Vol. TRC-1, No. 1, February 1955 (24 pages)	.95	1.40	2.85
	Vol. TRC-1, No. 2, May 1955 (24 pages)	.95	1.40	2.85
	Vol. TRC-1, No. 3, August 1955 (12 pages)	.70	1.05	2.10
Ultrasonics Engineering	PGUE-1: June 1954 (62 pages)	1.55	2.30	4.65
	PGUE-3: May 1955 (70 pages)	1.45	2.20	4.35
Vehicular Communica- tions	PGVC-3: June 1953—Spectrum Conservation, Washington, D. C., December 3-5, 1952 (140 pages)	3.00	4.50	9.00
	PGVC-4: June 1954—Design, Planning & Opera- tion of Mobile Communications Systems (98 pages)	2.40	3.60	7.20
	PGVC-5: June 1955 (76 pages)	1.50	2.25	4.50

\* Public libraries, colleges, and subscription agencies may purchase at IRE member rate.

H. F. OLSON RECEIVES JOHN SCOTT AWARD

Harry F. Olson, pioneer sound engineer and scientist of the Radio Corporation of America and an IRE Fellow, received the John Scott Award, which includes a copper medal and \$1000, recently at a dinner meeting of the Engineers' Club of Philadelphia for a 25-year-old invention, the velocity microphone which revolutionized the technique of sound pickup in the early 1930's and is still the standard microphone throughout the broadcasting and motion picture industries. The dinner marked the observance by the Engineers'



H. F. OLSON

Club of the 250th anniversary of the birth of Benjamin Franklin.

Since its establishment in 1816 by a Scottish chemist, awards have been made to more than five hundred men and women of various nationalities.

In announcing this year's award, the advisory committee pointed out that "the usefulness of this device to mankind is dramatically demonstrated by the fact that in the third decade after its invention, the microphone is still widely used for new and replacement applications, is still the standard of perfection in many fields of use, and has yet to be faced with a competitive unit which shows promise of such usefulness."

Dr. Olson recalled that the velocity microphone had been developed to meet the need for a pickup device which would remove restrictions on motion and action. This microphone responded to the velocity of air particles set into motion by sound which reached the microphone directly from the source.

E. N. DINGLEY, JR. WINS DEFENSE DEPARTMENT AWARD

Charles E. Wilson, U. S. Secretary of Defense, recently presented the Department of Defense Distinguished Civilian Service



E. N. DINGLEY, JR.

Award to Edward N. Dingley, Jr. of the National Security Agency at a ceremony at the Pentagon.

The award is the highest that is conferred on civilians by the Department of Defense. Mr. Dingley received his award in recognition of the solutions he developed to NSA communications problems, the Department reported today.

Mr. Dingley's inventions have resulted in invaluable improvements in the reliability and capacity of existing agency communication circuits, and in savings to the government of over \$1,000,000.

A native of Kalamazoo, Mich., he attended Massachusetts Institute of Technology for three years and received the B.S. degree from George Washington University in 1936. He is a Fellow of the IRE.

Mr. Dingley was with the Navy from 1926 to 1929 and then joined the Naval Research Laboratory staff in 1932 and the Navy Bureau of Ships from 1934 to 1942, followed by four years of active duty with the U. S. Naval Reserve.

The award included a medal and citation.

Dr. Olson, who is now Director of the Acoustical and Electromechanical Research Laboratory, RCA Laboratories, at the David Sarnoff Research Center in Princeton, N. J., developed the velocity microphone in 1930 when he was a member of the RCA research staff at Van Corlandt Park in New York City.

Committee Chairmen for 1956 Canadian IRE Convention at Toronto



Members of the committee responsible for the Canadian IRE Convention and Exposition, which will be held at Toronto on October 1-3, 1956, are shown above. (Seated, left to right): Clive Eastwood, Recording Secretary; R. C. Poulter, Advertising, Publicity and Program; E. O. Swan, Exhibits and Registrations; C. A. Norris, General Convention Chairman; George Sinclair, Technical Program; A. P. H. Barclay, Chairman of the Toronto Section of IRE; Claude Simmonds, Corresponding Secretary. (Standing, left to right): F. H. R. Pounsett, IRE Region 8 Liaison; C. H. Hathaway, Finances; Grant Smedmor, Convention Manager; and E. L. Palin, Social Activities.

## PHILADELPHIA SECTION SPONSORS STUDENT FORUM ON ELECTRONIC CAREERS

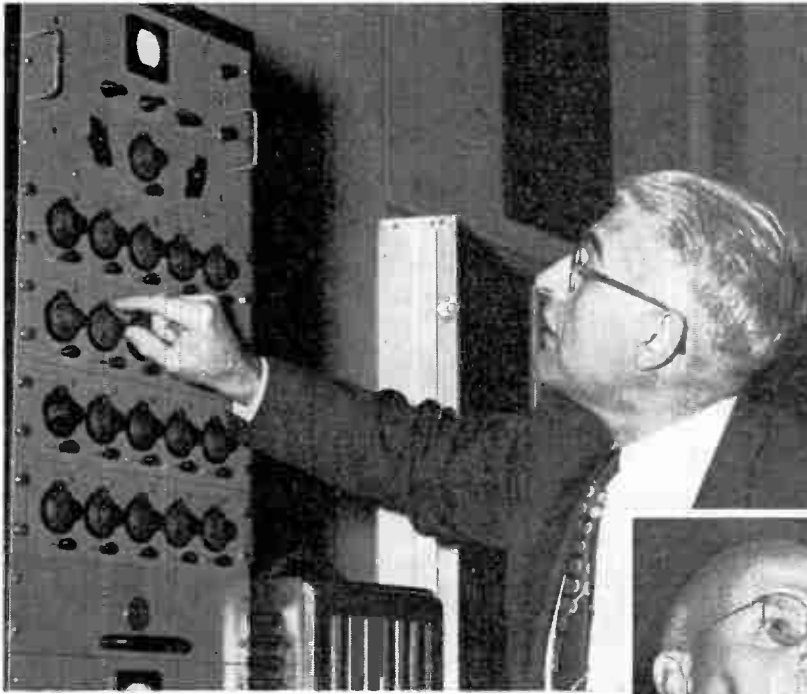

*Left*—C. N. Hoyler, RCA Labs., solves simultaneous equations on electronic analog computer. Demonstrations of a digital counter functioning as an electronic stop watch and the electronic computation of radiation patterns of broadcast antennas were also made. Over 900 teachers and secondary school students attended the forum sponsored by the Philadelphia Section and Franklin Institute. Thirteen electronic companies in the Greater Philadelphia area participated.



*Right*—Transistors, actual size and cut-away mode! enlarged 25 times, were shown by A. S. Barnes, Bell Telephone Co. of Pennsylvania. Included in the transistor demonstration were a wrist-watch broadcast receiver and an audio oscillator. Objective of this demonstration and others was to show dramatically the opportunities in the field of electronics for those who undertake college training in engineering and science. Moderator D. G. Fink of the IRE pointed out that 18,000 engineering jobs went begging for want of takers in 1955, and that the highest-paid people, in the age group from 21-25, are those having college training in engineering, physics, and chemistry.



*Left*—W. H. Forster, Philco Corporation, reveals the location of vidicon camera tube in the industrial television camera. By means of this camera mounted above a microscope students were able to view microscopic images of paramecia relayed over to television receivers by a 35-foot microwave relay hop across the entire hall.

## Ninth Annual Convention Held by Buenos Aires Section



Shown (left to right) in Radio Belgrano's television studio are: A. H. Cassiet, J. M. Rubio, Mrs. Rubio, Mrs. Guzzi, P. N. Guzzi, former Section president, and Mrs. Cassiet. Earlier the group had toured the TV station.



Above: Dante Tartaglia, an engineer from Uruguay, spoke on recent developments in radio in that country. Below: O. C. Fernandez, Section member, chats with L. M. Ygartua, the Argentinian Minister of Communications (center) and Ramon Casanova, the Assistant Secretary of Communications for Argentina (right).

The Buenos Aires Section held its Ninth Annual Engineering Week last November 21-25. The program included two general meetings, three technical tours, and five talks on engineering subjects. This year the usual electronics exhibition was omitted.

A cocktail party at the Confrateria del Molino, one of the fashionable places in Buenos Aires, opened the five-day convention. J. M. Rubio, President of the Section, and A. H. Cassiet, president of the organizing committee, delivered talks on the aims of the IRE and the accomplishments of the Buenos Aires Section.

The following day IRE members toured Radio Belgrano's Station LR-3-TV to inspect the transmitting and antenna television equipment, and during that evening a performance was staged especially for the members at the television studios located in Buenos Aires.

On November 23, talks were given by A. R. Isernia on the development of the na-

tional telegraphic network, Adolfo Di Marco on the subject of television today and tomorrow, and L. M. Malvarez on the purpose of engineering and technical training in electronics. A discussion, under the direction of P. J. Noizeux, followed. The meeting then adjourned for an informal dinner.

Convention visitors toured the engineering installations of the transmitting station of the Compania Internacional de Radio Argentina (CIDRA) the next day. This company, an associate of the International Telephone and Telegraph Corporation, gave an outdoor luncheon for the visitors. The following day Mario Giampietro and Dante Tartaglia, members of the Instituto de Radiotecnico del Uruguay, delivered addresses on "The Basis for TV Standards Adopted by Uruguay" and "A Review of the Latest Radio-Communication and Broadcasting Accomplishments in Uruguay." In the evening a banquet closed the convention.



## ELECTRONIC COMPONENTS SYMPOSIUM TO BE HELD MAY 1-3

The 1956 Electronic Components Symposium will be held on May 1-3, 1956, in the auditorium of the Department of the Interior, Washington, D. C. The symposium is sponsored by the IRE, AIEE, RETMA, and WCEMA, with the active participation of the agencies of the Department of Defense and the National Bureau of Standards. The Roger Smith Hotel will be registration headquarters.

Its seven sessions will include papers on components, instrumentation, transistors and other semiconducting devices, electron tubes, electromechanical devices, indicating instruments and solid state devices.

### PROCEEDINGS NOW AVAILABLE

Proceedings of the second annual Computer Applications Symposium, held Oct. 24-25, 1955 at Armour Research Foundation of Illinois Institute of Technology, Chicago, are now available. Copies of the proceedings may be obtained by sending \$3.00 to H. H. Kantner, Electrical Engineering Research Department, Armour Research Foundation of Illinois Institute of Technology, Technology Center, Chicago 16, Illinois.

## Over Seven Hundred Attend Second National Reliability-Quality Control Symposium



D. A. Hill (center), program chairman, and R. H. DeWitt (right), Office of the Assistant Secretary for Defense, greet Lt. Comdr. G. V. de Gabriole, French Naval Department, Paris. Symposium visitors attended a total of sixteen sessions and heard Major General J. E. Briggs, Assistant Deputy Chief of Staff Operations, USAF Headquarters, deliver a luncheon address on "Progress in the Air Defense of the North American Continent."

## TENTH ANNIVERSARY OF NEW ENGLAND RADIO-ELECTRONICS MEETING SET FOR APRIL 23-24

On the theme, "A Stocktaking of Electronic Progress—The Present and Future," the New England Radio-Electronics Meeting observes its tenth anniversary on April 23-24. Technical papers, social events, and one hundred exhibits of electronic products will round out a two-day schedule of activities at the Sheraton-Plaza Hotel, Boston, Massachusetts.

The tenth-anniversary NEREM, sponsored jointly by the Boston and the Connecticut Valley Sections, is directed by a committee under the leadership of Beverly Dudley, of the M.I.T. *Technology Review*. The subcommittee chairmen are: *Program*, K. C. Black, Raytheon Manufacturing Co.; *Exhibits*, R. M. Purinton, Richard Purinton, Inc.; *Publicity*, Col. H. O. Bixby; *Arrangements*, S. B. Fishbein, American Machine and Foundry Co.; *Student Counsellor*, T. F. Jones, Jr., Massachusetts Institute of Technology; *Connecticut Valley Chairman*, P. F. Ordnung, Associate Professor of Electrical Engineering, Yale University; *Secretary-Treasurer*, R. B. Lawrence, Datamatic Corp. Members-at-large include R. A. Waters, *Past NEREM Chairman*; L. E. Packard, *Regional Director*; and T. P. Cheatham, *Chairman, Boston Section*.

The technical sessions program will comprise morning and afternoon sessions on both Monday and Tuesday. On the theme "Present Building Blocks of Electronics," the Monday morning session, with T. P. Cheatham as moderator, will include the following papers: *Practical Components at Extremely Low Temperatures* by Dudley Buck, M.I.T.; *New Developments in Magnetics and Dielectrics* by C. L. Hogan, Harvard University; *Time and Frequency and Their Measurement* by J. R. Zacharias, M.I.T.

The Monday afternoon session, on the theme, "Present New Influences in Thinking," P. F. Ordnung, moderator, will include the papers *Electric Wave Propagation* by

W. H. Radford, Lincoln Laboratory; *Computers* by J. J. Eachus, Datamatic Corporation; and *Systems Reliability* by Arthur Kohlenberg, Melpar, Inc.

On Tuesday morning, C. R. Burrows will be the moderator for a session titled "The Future of Electronics—The Shape of Things to Come." Papers scheduled are: *Transoceanic Television* by D. G. Fink, Philco Corporation; *Chemistry and Metallurgy in Electronics* by William Baker, Bell Telephone Laboratories; *Future of Solid State Physics* by Ivan Getting, Raytheon Manufacturing Company.

The Tuesday afternoon session, under the direction of T. P. Jones, will have as its theme "Students—Professional Growth and the IRE." At this session, student competition papers from southern New England, northern New England, and northern New York will be presented, followed by a panel discussion and award of prizes. T. H. Kerby of Yale University will act as moderator.

Social activities will consist of a buffet dinner Monday evening and a luncheon with entertainment Tuesday noon.

## R. F. METTLER CITED BY U. S. JUNIOR CHAMBER OF COMMERCE

R. F. Mettler, Director of Advanced Systems Planning, Ramo-Wooldridge Corp., Los Angeles, has been named one of the "Ten Outstanding Young Men of America" for 1955 by the United States Junior Chamber of Commerce. He was cited for contributions in rocket fire control developments and classified military electronics.

Dr. Mettler recently completed a year's service as special consultant to the department of defense working on highly classified projects in the field of military electronics. Now an engineering executive for the Ramo-Wooldridge Corporation, Los Angeles, California, he is currently organizing a new graduate level course in systems engineering for the California Institute of Technology.

In 1949, working for the Hughes Aircraft Company, Mettler and three associ-

ates completed an original analysis and systems invention which has led to development and production of vastly more effective rocket fire control systems. Later he was leader of the group which analyzed and planned a completely integrated interceptor electronic system which included navigation, rockets, guided missiles, homing, landing, and automatic pilot functions. Before leaving Hughes Aircraft in 1954 to serve the Department of Defense, Mettler's ability and technical management skill led him to department head responsibilities involving these and other systems, and several patent applications on his inventions. At the Department of Defense he served as associate director of the radar research and development division.

After enlisting in the Navy in 1942 as an apprentice seaman he graduated from California Institute of Technology, Naval Midshipmen's School at Columbia University and Massachusetts Institute of Technology Radar School. During his tour of duty he was assigned as a field service engineer for shipborne radar and fire control equipment and after the war was assigned for six months' duty in connection with the Bikini atomic bomb tests.

Returning to the California Institute of Technology he obtained a Master's degree in electrical engineering in 1947 and a Ph.D. in electrical engineering and aeronautics in 1949. As a graduate student he taught applied mechanics and during this period was consultant to the North American Aviation Aerophysics Laboratory and the Halliburton Oil Well Cementing Company. Together with a colleague he invented and built a new electronic system for grading earth formations in seismological oil explorations.

He is a member of Tau Beta Pi, Sigma Xi and Eta Kappa Nu. He is an Associate of the IRE.

The United States Junior Chamber of Commerce annually honors men, from 21-35 years of age, who have made exceptional contributions to their professions and communities at its January banquet.



Photos from 1955 NEREM show 1955 IRE President J. D. Ryder presenting the School Trophy to T. S. Gray, and (right) some of the exhibits at the Sheraton-Plaza Hotel.

## PROFESSIONAL GROUP NEWS

### PGANE LUNCHEON IS SCHEDULED DURING IRE NATIONAL CONVENTION WEEK

The Professional Group on Aeronautical and Navigational Electronics will hold its annual luncheon at the Ambassador Hotel, New York City, March 20. Trevor Gardner, Assistant Secretary of the Air Force for Research and Development will deliver the luncheon address entitled "Maintaining Technological Superiority."

### PROFESSIONAL GROUP ON MILITARY ELECTRONICS ELECTS FIRST PERMANENT OFFICERS

The Professional Group on Military Electronics elected the following: *Chairman*, C. L. Engleman; *Vice-Chairman*, Gordon Gould; *Secretary*, C. R. Busch; and *Treasurer*, Howard Engstrom. Committee chairmen also appointed were: *Awards*, G. L. Haller; *Meetings*, S. E. Petrillo; *Membership*, W. H. Richardson; *Nominations*, M. B. Carlton; *Papers and Publications*, J. Q. Brantley, Jr.; *Section Activity and Group Chapter*, E. A. Speakman.

The assessment fee for IRE members to join this Group was levied at \$1.00.

A chapter of PGMIL has been formed in Washington, D. C.

## OBITUARIES

**Greenleaf Whittier Pickard** (M'12-F'15) inventor and radio engineer, died recently at the age of 78. He was a grandnephew of John Greenleaf Whittier, the poet.



G. W. PICKARD

Mr. Pickard was one of the first scientists to obtain successful transmission of speech by electrical waves. He invented the crystal detector, the radio compass and the static eliminator.

Mr. Pickard attended Lawrence Scientific School at Harvard and the Massachusetts Institute of Technology.

He was a Charter Member and Life Member of the IRE. He served as its President in 1913. He was awarded the IRE Medal of Honor in 1926. In 1941, he received the Armstrong Medal from the Radio Club of America, of which he was a Fellow.

At the time of his death, Mr. Pickard was chairman of the board of Pickard & Burns, Needham, Mass. From 1902 to 1906, he was an engineer for the American Telephone and Telegraph Company and, from 1907 to 1930, consulting engineer for the Wireless Specialty Apparatus Company. He was also a consultant to the RCA-Victor Company of Massachusetts and director of research for the American Jewels Corporation of Attleboro, Mass.

He held over a hundred United States and foreign patents for his inventions.

Mr. Pickard was also a member of the American Institute of Electrical Engineers, the American Association for the Advancement of Science, the American Academy of Arts, and the American Meteorological Society.



**Captain Willis H. Beltz** (SM'53-F'56), USN (retired), died on January 17, 1956, following a long illness. From June, 1952, until April, 1955, he had been Director of the Naval Research Laboratory, in Washington, D. C.



W. H. BELTZ

A native of Martinsville, Illinois, Captain Beltz received the Bachelor of Science degree from the University of Kansas in 1921, following service in World War I as a second lieutenant in the field artillery, U. S. Army.

After a year with General Electric following graduation, he joined RCA, where he was employed in various engineering capacities from 1922 to 1941. He had been commissioned a lieutenant in the Naval Reserve in 1925, and, in 1941, was called to active duty in the Electronics Division of the Bureau of Ships. While serving as Officer-in-Charge of the Shore Radio Group, he was awarded the Legion of Merit for his outstanding efficiency and skill in obtaining and directing installation of the most advanced radio equipment for wartime fleet communications.

Captain Beltz' next duty was as Electronics Officer at the Navy Yard in Philadelphia. In 1946, he reported as Industrial Manager of the Fifteenth Naval District, Balboa, Canal Zone. In 1948, he returned to Washington and to the Bureau of Ships as Deputy for Electronics and later as Assistant Chief for Electronics. In June 1952, he became NRL's Director.

Captain Beltz had been made a Fellow of the IRE this year for leadership in improving the reliability of military electronic systems."



**Alexander E. Reoch** (M'14-F'16) died recently. He was a Life Member of the IRE and its Manager from 1925 to 1927. He also served on the Meetings and Papers, and Standardization committees in 1925.

He had received his degree in electrical engineering at Sheffield University College, Sheffield, England.

## TECHNICAL COMMITTEE NOTES

The **Electron Tubes** Committee met at IRE Headquarters on January 13 with Chairman P. A. Redhead presiding. The chairman reported that the Proposed Standards on Electron Tubes: Definitions of Storage Tubes was approved at the December meeting of the Standards Committee

and will appear in the April, 1956 issue of PROCEEDINGS. The remainder of the meeting was devoted to the review of the following proposed standards: Proposed Standard on Electron Devices: TR and ATR Tube Definitions; Proposed Standard on Electron Tubes: Cathode Ray Tube Definitions; Proposed Standard on Electron Tubes: Receiving Tube Definitions.

Chairman K. R. McConnell presided at a meeting of the **Facsimile** Committee at the Times Building on December 16, 1955. The committee reviewed the Proposed Standard on Facsimile: Definitions of Terms and made revisions based on the comments of the Standards Committee. The chairman reported that the IRE Facsimile Test Chart will be distributed by the RETMA under the quality control of the IRE as supervised by the IRE Facsimile Committee. The Test Chart will retain the IRE copyright.

The **Piezoelectric Crystals** Committee met at IRE Headquarters on December 14, 1955 with Chairman Hans Jaffe presiding. The report of the subcommittee on measurement standards was considered in two parts: Part I, A Proposed Standard on Crystal Measurements, and Part II, A Proposed Standard on Piezoelectric Vibrators. The Proposed Standard on Ferroelectric Materials was returned to a subcommittee for revision. The scope of the work of the Piezoelectric Crystals Committee and its relation to that of the Solid State Devices Committee was discussed.

Chairman E. Weber presided at a meeting of the **Standards** Committee at IRE Headquarters on January 12, 1956. Dr. Weber read the following resolution adopted by the Board of Directors at the January 5, 1956 meeting: "The Board of Directors, noting a reference in a recent public notice of the Federal Communications Commission, calling for the use of certain IRE Standards, takes this occasion to congratulate the Standards Committee on the good and useful work it has done on these and other Standards." A. G. Jensen said that the IRE has been invited to send a representative to the Conference on Magnetism to be held at M.I.T. in September, 1956. The committee decided that the IRE should be represented and will appoint a representative shortly.

The Proposed Standards on Facsimile: Definitions of Terms was discussed, amended and unanimously approved on motion by J. G. Kreer and seconded by R. F. Shea.

The committee discussed and amended the Proposed Letter Symbol Standards for Semiconductor Devices. Review of this proposed standard will be completed at the next meeting of the Standards Committee.

The **Video Techniques** Committee met at IRE Headquarters on January 3, 1956, with Acting Chairman V. J. Duke presiding. The committee reviewed the work done by Subcommittee 23.1 on Definitions. J. M. Barstow, Chairman of Subcommittee 23.4 on Video Signal Transmission: Methods of Measurement, reported that the subcommittee discussed IRE roll-off characteristics and agreement was reached as to design objective curve and tolerances to be associated with it. Work is progressing toward including the new curves in a proposed revision of present standards for Television signal level measurements.

# Books

## Color Television Receiver Practices by the Hazeltine Corp. Laboratories Staff

Published (1955) by John F. Rider Publisher, Inc., 480 Canal Street, N. Y. 13, N. Y. 194 pages+4 page index+vii pages. 96 figures. 5½×8½. \$4.50 in paper, \$6.00 in cloth.

This book will be of interest to engineers who are familiar with monochrome television receivers. It does not review basic television material, and the information in the chapter on the transmitted color signal is limited to essentials which are presented without detail explanation. The subject of the color receiver is treated from the practical viewpoint in a concise and easily readable form. Accordingly, the relatively small book covers all the new areas in a color receiver. Although each chapter was written by a different author over-all relationships of technical material are well established.

The text is broad enough to cover many alternate circuit arrangements. The section on decoders covers both simultaneous and sequential systems and is an authoritative source on decoding procedures. A section on laboratory apparatus describes much of the special equipment commonly used in color signal generating facilities.

The book is on the basic level for receiver design engineers and is also recommended to those interested in understanding the fundamental engineering requirements of a color receiver.

W. P. BOOTHROYD  
Philco Corporation  
Philadelphia 34, Pa.

## Instrument Engineering: Vol. III, Applications of the Instrument Engineering Method; Part One, Measurement Systems by C. S. Draper, Walter McKay and Sidney Lees

Published (1955) by McGraw-Hill Book Co., Inc., 330 West 42nd St., N. Y. 36, N. Y. 843 pages+xxviii pages+18 page index+15 page bibliography. Illus. 11¼×8½. \$17.50.

The present book is part I of the two parts of the third and final volume of "Instrument Engineering," by the three authors from the Aeronautical Engineering Department and Instrumentation Laboratory at M.I.T. The three volumes are intended to serve as a reference book for the field of instrumentation.

In the first two volumes, the basic analytical tools were presented, with Volume I emphasizing the techniques for the description of physical situations and Volume II, the basic theory of analysis. Volume III has been written to illustrate the application of these techniques to instrumentation problems, with the present part emphasizing measurements (thermometry, analog computation techniques, electromechanical, pressure, and vibration measurements) and the second part to illustrate the application in more complex control and instrumentation systems with feedback.

The book is not an instrumentation handbook, as it does not include extended descriptions of the operating characteristics, frequency range, loading effects, etc. of transducers, but rather it is a reference book

of analysis techniques and approaches and includes qualitative descriptions of a vast number of transducers. In a typical case, the transducer is described qualitatively, the differential equation presented on the basis of the fundamental physical laws, and then, for a class of transducers, non-dimensionalized transient and frequency responses are given.

The method of presentation is essentially one of case histories, with a heavy dependence on the "derivation summary" and similar tabulations so familiar to those who have read the first two volumes (although the present volume does stand alone and does not assume familiarity with the earlier volumes).

Like Volumes I and II, the present book unquestionably represents a highly significant contribution to the literature of the instrumentation field. For the university teacher the book provides a wealth of background knowledge to ease his work as the concepts of instrumentation gradually filter into the undergraduate curriculum. For the practicing engineer the book should serve as a useful reference for instrumentation problems. Also like Volumes I and II, the impact of the book among electrical engineers will undoubtedly be severely limited by the notation, which is no less formidable-looking than in the earlier volumes. For their attempts to bring forth a unifying system of notation, the authors are certainly to be lauded, but in the reviewer's opinion the great wealth of material in the earlier volumes has never been adequately appreciated largely because of this notation.

The only other criticism is related to the size of the three volumes, a size which seems to be to some extent the result of the attempt to make the various volumes and sections stand alone. As a consequence of this attempt, there is a great deal of repetition, which is augmented by the presentation of many ideas both in tabular form and in the text. But the authors of such an ambitious undertaking are hardly to be criticized on such a minor and debatable ground, and the over-all impression of the three volumes is certainly that these represent a development of great significance in the field.

J. G. TRUXAL  
Polytechnic Institute of Brooklyn  
Brooklyn, New York

## Fundamentals of Television Engineering by G. M. Glasford

Published (1955) by McGraw-Hill Book Company, Inc., 330 W. 42 St., N. Y. 36, N. Y. 599 pages+xiv pages+11 page index+12 page appendix. 566 figures. 9¼×6¼. \$12.75.

The author has prepared a reference work, which, as the title implies, is intended to cover the fundamental principles of the entire field of television engineering. It may be said that he has made a fine and able attempt to satisfy that purpose.

The treatment of visual characteristics, color specification, and signal analysis is quite satisfactory, but it appears that the section dealing with electron-beam scanning, as well as that dealing with image-pickup

tubes and output circuits, could have been made more practical and more explanatory insofar as operating practices are concerned.

There is an excellent treatment of wide-band radio-frequency amplifiers, as well as a fine explanation of television-receiver fundamentals and designs.

It is thought that the book may be of some use to those engineers who may wish to include it among the growing library of television engineering textbooks which have come into use during the past few years. It will prove an excellent textbook for use as a general reference work in the average radio engineer's library.

SCOTT HELT  
Allen B. Du Mont Laboratories, Inc.  
Clifton, New Jersey

## Transistor Electronics by A. W. Lo et al

Published (1955) by Prentice-Hall, Inc., 70 Fifth Ave., N. Y. 11, N. Y. 508 pages+13 page index+xii pages. 354 figures. 8½×5½. \$12.00.

This book, which is written for advanced undergraduate or graduate students in electrical engineering and associated fields, and as a reference work for electronics engineers, makes a worthy and timely contribution to the field of transistor circuit development. Even though the book has five authors, it has excellent continuity and there is virtually no overlap of material from one chapter to another.

Chapter 1 of the book presents a brief and not unusual qualitative discussion of some fundamental concepts of transistor physics. Chapter 2 considers the static characteristics of transistors and their small signal four pole parameters. In Chapter 3, the three basic transistor amplifier configurations are analyzed in order to determine their electrical properties. The results are tabulated for convenient reference. Transistor noise is discussed much too briefly for a good engineering understanding. Incidentally, several of the noise equations are in error. Chapter 4 gives a good treatment of d-c biasing. Low frequency amplifiers are described in Chapter 5 and power amplifiers in the next chapter. This latter chapter is inadequate as compared with similar work in standard electron tube circuit texts. Chapters 7 and 8 are the highlights of the book. Here a quantitative discussion of transistor physics is presented with particular emphasis placed on high frequency device properties. The design of high frequency amplifiers is discussed in Chapter 9. Chapter 10 treats of oscillators. Chapter 11 is a particularly good discussion of modulation and demodulation. Chapter 12 which covers pulse circuits is a disappointment.

The outstanding feature of the book is the excellent treatment of high frequency properties of junction transistors. The short circuit admittance parameters of the intrinsic transistor are obtained by a straight forward solution of the diffusion equation subject to the proper boundary conditions. An exact equivalent circuit is then derived from these parameters. This is simplified in order to obtain practical equivalent cir-

cuits which are valid over the useful operating frequency range of the device. Much of this material is original. Noteworthy innovations introduced in this book are (a) the emphasis placed on the common emitter connection because it is more widely used than the other transistor connections, (b) use of a new symbol to represent the junction transistor for better functional representation and to distinguish it from the point contact transistor.

As can be expected in any text which attempts to cover comprehensively a field as new as transistor electronics, the book has several deficiencies. Feedback, which is especially important for transistor amplifiers in order to stabilize gain, input and output impedances, and bandwidth against variations in transistor parameters is given only a brief superficial discussion. The treatment of junction transistor pulse circuits is also inadequate. In particular, the Ebers and Moll equations are not discussed sufficiently, the limitations of the junction transistor pulse circuits are not covered, and the blocking oscillator is omitted entirely. In general, the point contact transistor receives too much attention in Chapters 10 and 12 as compared with the treatment of junction transistors.

The many outstandingly favorable qualities of this book greatly outweigh its few shortcomings. The book will serve as a valuable reference work for engineers and physicists engaged in transistor electronics. It will also be particularly useful as a college textbook.

A. J. GROSSMAN AND F. H. BLECHER  
Bell Telephone Laboratories, Inc.  
Murray Hill, New Jersey

### Principles of Electromagnetism, 3rd ed., by E. B. Moullin

Published (1955) by Oxford University Press, 114 S. Ave., N. Y. 11, N. Y. 434 pages + viii pages + 4 page index. 172 figures. 9½ × 6½. \$7.00.

The text, of which this is the third edition according to the author's preface, was originally planned as a basic work to precede a text on the "Electromagnetic Principles of the Dynamo." As such, it concentrates much more on magnetic problems, the effects of iron, the use of magnetic shells as equivalent to current flow, and the usefulness and limitations of the "cutting rule" for e.m.f. than the classical works on electromagnetic theory, or later works slanted toward high frequency applications. With the large number of problems and worked-out examples, it has thus been especially useful for engineers concerned with electromechanical systems, but has also provided a different point of view for those interested in high frequency applications. However, it could not be considered as complete for the latter group since it goes only so far as demonstrating the radiation of energy from a straight wire, and there are no problems on this aspect of the phenomena.

This third edition makes use of the text of the second edition, with one hundred twenty-five pages of new material added in appendices. The added material includes treatments of the energy loss in condensers with various shapes of lossy dielectrics, skin effect, self-inductance and magnetic forces for conductors of various shapes, many

electrostatic and magnetostatic problems with cylinders, and the solutions for spheres, ellipsoids and other conductors in a uniform magnetic field. As in the original text, there are many problems and worked-out examples. This edition includes examples from the Mechanical Sciences Tripos for 1947-1951. Since the added material is largely concerned with specific examples, its appearance in the appendices rather than as a revision of the original text causes no inconvenience.

Units are the classical e.m.u. and e.s.u. It would seem in order at least to discuss the MKS system. Other minor modernizations of the original text would be desirable, such as the footnote on page 109 stating "the only substances which are appreciably magnetic are iron, nickel, cobalt and their alloys." And, although many ingenious methods of solving practical problems are introduced in the examples, others are made unnecessarily complicated by the avoidance of standard methods of boundary value solution, such as the use of conformal transformations, graphical field mapping, and the use of standard transcendental functions.

J. R. WHINERY  
University of California  
Berkeley 4, California

### Color Television Engineering by J. W. Wentworth

Published (1955) by McGraw-Hill Book Company, 330 W. 42 St., New York 36, N. Y., 430 pages + 8 page index + 19 page appendix + xix pages. 296 figures. 9½ × 6½. \$8.00.

The essential ingredients of a book entitled *Color Television Engineering* might well be first, a sound, thoroughgoing, and easily understood discussion of color and colorimetry; second, an equally detailed discussion of the underlying principles and techniques of NTSC color television; and third, a disclosure of how these principles and techniques are realized in practical apparatus. Mr. Wentworth provides the first ingredient in excellent fashion. The last two ingredients appear to leave something to be desired.

The book is divided into an introduction and four parts. Part One discusses "Basic Principles of Color, Color Perception and Color Measurement," while Part Two is devoted to "Principles of Color Reproduction." These two sections will be of real help not only to engineers and students who tackle color television for the first time, but also to many of the men who are already immersed in the field.

Part Two, "Principles of Color Reproduction," immediately applies the discoveries of Part One, and is to be particularly commended for the inclusion of Chapter 5, "Color Photographic Processes."

Of the remaining two parts of the book, Part Three deals with "Principles of Color Television Transmission Systems." Here is the logical place to elaborate on these techniques which make up the fundamental building blocks of the NTSC transmission scheme. Two of these are the frequency interleaving technique and the principle of "quadrature," "synchronous" or "two-phase" modulation of the chrominance information upon the subcarrier. The treatment of both subjects is a little disappointing. To the uninitiated reader the explana-

tion of frequency interleaving will be confusing because of an unfortunate emphasis upon the *frame* frequency rather than the *line* frequency of a television image as a parameter in determining the visibility of an added subcarrier. Mr. Wentworth's position is academically correct, but it is also of little more than academic interest. Spectrum diagrams, waveforms, and dot patterns would substantially enhance this portion of the text.

It is also surprising to find that the reader is introduced to the idea of "two-phase" modulation without the aid of vector diagrams. To this reviewer it would appear to be almost essential to resort to the time-honored "revolving blackboard" in discussing such a technique. Instead, one must negotiate several pages of schematic diagrams and written material before finally arriving at Section I, page 227, which shows vector diagrams and is entitled, "The Need for Double Sidebands in Two-Phase Modulation."

Some readers will criticize Part Three as being superficial in its treatment of a few other important subjects. For example, the "packaging" of the simultaneous color information from the camera into luminance and chrominance voltages of the NTSC signal is accomplished in words in one short paragraph. The practical design of matrices, a simple enough subject but there are some useful shortcuts, receives no attention. The necessity for delay equalization at the transmitter and receiver is mentioned, but no quantitative information is provided to assist the designer of such apparatus. In short, Part Three will give the reader a good idea as to what the NTSC color television system is, but it will not tell him very much about how to *engineer* apparatus for the transmitter and receiver. It will not give him a feel for the practicalities of color television engineering.

Part Four of the book considers "Apparatus and Circuits for Color Television," and, in common with most discussions of practical apparatus, places the emphasis upon *what* rather than *why*. Pickup equipment, encoding apparatus, receivers, and test gear are all described in a way which would be quite satisfactory if Part Three of the book were technically somewhat stronger.

Notwithstanding these comments, Mr. Wentworth's book is a valuable contribution to the literature on color television. In many places it shows the leavening effect and smooth development of ideas which are characteristic of a text prepared from lecture notes. This reviewer believes that the book should be recommended not only to the television fraternity but also to the attention of students and casually interested technicians and engineers who would like to become acquainted with the current status of the television field.

R. P. BURR  
Hazelton Corporation  
Little Neck, New York

### Electrons, Waves and Messages, by J. R. Pierce

Published (1956) by Hanover House Division of Doubleday and Co., Inc., 575 Madison Avenue, New York 22, N. Y. 309 pages. \$5.00.

The author of *Electrons, Waves and Messages* is noted among his fellow electronic

engineers for his ability to use mathematics imaginatively to create new electronic devices, and to analyze their behavior. For this work he received such recognitions as the Morris Liebmann Memorial Prize of the IRE, and election to the National Academy of Sciences.

As an avocation, he has under a pseudonym developed quite a following as a writer for science fiction magazines. For these activities he is paid real money, and gets invited to join clubs of authors who write literature and not science.

*Electrons, Waves and Messages* is a result of the merger of these schizophrenic qualities. It is unique among books that attempt to interpret science in a "popular" manner. Such books are ordinarily written either by a scientist whose ideas are better than his ability to express them, or by a professional writer who can express his thoughts cleverly but doesn't have much to say that possesses scientific originality. This book suffers from neither of these failings.

This book is about the science of electronics, and the electronics of communication. It is not a text, but rather a philosophical discussion of electronics written in simple and interesting language. A surprisingly wide range of subjects is covered. There are chapters dealing with electron dynamics, fields, waves, radiation, microwave tubes, noise, microwave communication systems, television, communication theory, quantum

mechanics concepts as applied to the transistor, etc. The treatment is characterized by broad perspective and a touch of the philosopher. Reader interest is maintained by the way in which the techniques of electronics are associated with related subject matter. Thus it is shown how the principles determining the beam width of a microwave antenna also determine the smallest object on Mars that can be isolated by an astronomical telescope, how the concept of entropy can be applied to messages, how the principles of radiation and absorption of energy can be used to determine whether a man in a space suit will freeze or fry when in interstellar space, etc. The entire treatment is characterized by a literary skill that is entirely absent from the usual book written by an engineer or scientist.

*Electrons, Waves and Messages* has something in it to appeal to everyone interested in electronics. Thus every researcher, irrespective of how sophisticated, will find sections that will arouse his interest and broaden his horizons. At the same time, even the beginner will find much in this book that he can understand, and that is of value to him.

Because of this wide appeal, different readers will favor different chapters. The reviewer obtained most enjoyment from Chapter 15, "The Unexpected," which is concerned with statistical phenomena, including the statistics of the English language, and of

art. Here among other things, it is pointed out that even a very elementary statistical test shows that the sequences of words commonly used in children's primers is very different from English as it is commonly spoken or written. The author calls the resulting language "primer pidgin," and thereby neatly pinpoints a matter that has bothered the author ever since his own children began reading: "See Dick. See Dick run. Run, Dick, run."

This chapter, "The Unexpected," concludes by considering the application of mathematics and statistics to art. The author cites how he and a collaborator, with the aid of some simple rules, three specially made dice, and a table of random numbers, created several musical numbers by purely statistical methods. These are reproduced in the book so that the curious may play them. After listening to these pieces a number of times, the author found they became more comprehensible, and were "pleasing rather than deep . . . less dull than poor hymns, but considerably inferior to Bach."

*Electrons, Waves and Messages* is recommended for anyone interested in electronics who, as a relief from books that must be painfully studied, would appreciate an electronics book that can be read just for pleasure.

F. E. TERMAN  
Stanford University  
Stanford, California

## TECHNICAL CONFERENCE AND EXHIBIT ON MAGNETIC AMPLIFIERS

HOTEL SYRACUSE, SYRACUSE, N. Y.—APRIL 5-6, 1956

A Special Technical Conference on Magnetic Amplifiers, co-sponsored by the AIEE Committee on Magnetic Amplifiers, the IRE Professional Group on Industrial Electronics, and the ISA, Central New York Section, will be held at the Syracuse Hotel, Syracuse, New York, on April 5-6, 1956. Technical sessions, a manufacturers' exhibit of magnetic amplifiers, components and associated products, and a banquet on Thursday evening, April 5, are planned. O. G. Haywood, Director of Sylvania Electric Waltham Laboratories, Waltham, Massachusetts, will be the banquet speaker.

The registration fee for the conference will be \$3.00 and the cost of the banquet Thursday evening will be \$5.00 per plate. Papers presented at the conference will be published subsequent to the conference in the report of the conference and will be available at \$4.00 each if ordered in advance, or at the conference. Exhibit space can be

obtained at a cost of \$2.50 per square foot. The usual booth size is 6'×8' or 6'×10'. This charge includes the booth, background curtains, a table, and chairs. Manufacturers desiring exhibit space are invited to contact S. Seely, Dept. of Electrical Engineering, Syracuse University, Syracuse, N.Y. For other information, write C. F. Spitzer, Building Three, General Electric Company, Electronics Park, Syracuse, New York.

Committee members are as follows: *Steering Committee*, C. F. Spitzer, H. W. Lord and A. B. Haines; *Technical Program*, P. L. Schmidt; *Publications*, David Feldman; *Hotel Arrangements*, John Becker; *Registration*, August Haedecke; *Finance*, J. W. Munnis; *Publicity*, F. J. Lingel; *Coordination*, C. F. Spitzer; *Exhibits*, Samuel Seely.

The first technical session will be tutorial in nature and will consist of four papers by guest speakers. The remaining three technical sessions will each consist of papers

chosen from those submitted to the technical program committee and will cover the subjects of materials, components, theory and application.

### SESSION I

*Chairman*: Paul Schmidt; *Co-Chairman*, J. E. Hart.

*A General Introduction to the Theory of Magnetic Amplifiers*, W. C. Johnson, Princeton University, Princeton, New Jersey.

*Recent Advances in the Theory of Magnetic Amplifiers*, R. Barker, Yale University, New Haven, Connecticut.

*Fundamentals of the Magnetization Processes*, Charles Bean, General Electric Company, Schenectady, New York.

*Present Methods of Core Evaluation, Matching and Grading*, R. W. Roberts, Westinghouse Electric Corporation, Pittsburgh, Pennsylvania.



## SESSION II

*Chairman:* August Haedecke; *Co-Chairman,* W. E. Good.

*Core and Lamination Shape Factors in Magnetic Amplifier Design,* H. R. Brownell, Magnetic Metals Company, Camden, N. J.

*An Analysis of Magnetic Amplifiers in Push-Pull,* L. A. Finzi and D. L. Critchlow, Carnegie Institute of Technology, Pittsburgh, Pennsylvania.

*Design Criteria for a Practical Flux-Reset Core Tester,* J. R. Jaquet, Westinghouse Electric Corporation, Baltimore, Md.

*A Sensitive Single Turn Hysteresis Loop Tester,* F. Bernstein, T. H. Bonn, R. D. Torrey, Sperry-Rand, Philadelphia, Pa.

*Correlation of Hysteresis Loops, Core Tests, and Magnetic Amplifier Control Characteristics,* W. J. Muldoon, General Electric Company, Utica, New York.

## SESSION III

*Chairman:* Fred Lingel; *Co-Chairman,* John Becker.

*Magnetic Amplifier Controlled Regulated Rectifiers,* H. L. Goldstein, R. J. Lowell, Bell Telephone Laboratories, Inc., Whippany, New Jersey.

*Regulated Power Supplies with Silicon Junction Reference,* D. Scorgie, Westinghouse Electric Corporation, Pittsburgh, Pennsylvania.

*A 75 KW Magnetic Amplifier,* K. Enslin, University of Rochester, Rochester, New York.

*A High Temperature Regulated DC Power Supply for Aircraft,* R. G. Engman, Westinghouse Electric Corporation, Pittsburgh, Pennsylvania, and R. E. King, Lima, Ohio.

*Half Cycle Response Magnetic Amplifiers with Transistor Driver for Voltage Regulation,*

## SESSION IV

*Chairman:* Samuel Seely; *Co-Chairman,* Norman Balabanian.

*A Magnetic Voltage Reference,* E. W. Manteuffel, R. O. McCary, General Electric Company, Ithaca, New York.

*Capacitively Coupled Magnetic Amplifiers,* H. W. Collins, Westinghouse Electric Corporation, Pittsburgh, Pennsylvania.

*60 Cycle Self-Balancing Magnetic Servo Amplifier,* W. A. Geyger, Naval Ordnance Laboratory, Silver Spring, Maryland.

*Magnetic Arbitrary Wave Form Generator,* C. B. House, Naval Research Laboratory, Washington, D. C.

*Magnetic Amplifiers for the Control of Servo Motors,* A. R. Perrins, Yale University

# SYMPOSIUM ON NONLINEAR CIRCUIT ANALYSIS

APRIL 25, 26 AND 27

The International Symposium on Nonlinear Circuit Analysis, II will be the sixth of a series sponsored by the Microwave Research Institute of the Polytechnic Institute of Brooklyn. It will be held on April 25, 26 and 27, 1956, at the Engineering Societies Building in New York City.

The program will consider basic methods and recent advances in the analysis and design of nonlinear networks and will emphasize the use of nonlinear network theory in the study of oscillators, feedback systems, switching and discontinuous systems, and nonlinear systems with random inputs. An exposition of the fundamental mathematical methods of analysis will be correlated with applications in such fields as automatic control where specific practical systems illustrate such nonlinear phenomena as subharmonic generation, parametric damping, jump resonance, and stabilized oscillation.

This series of international symposia was started in 1952 with the sponsorship of the Office of Naval Research. All three Armed Services Research Organizations and the IRE Professional Group on Circuit Theory subsequently sponsored succeeding symposia.

The cooperation of the PG on Circuit Theory, the Office of Naval Research, the Air Force Office of Scientific Research and the Signal Corps enable the symposium to eliminate admission charge or registration fees. Volume VI of the MRI Symposia Series *Proceedings of the Symposium on Nonlinear Circuit Analysis, II* will be published by October, 1956 at five dollars per copy, cloth-bound. Orders for the *Proceedings*, accompanied by check or money order made out to Treasurer, Symposium Committee, will be

accepted in advance. Copies of the detailed program, hotel accommodation information and registration forms are available on request. All correspondence should be addressed to Polytechnic Institute of Brooklyn, Microwave Research Institute, 55 Johnson Street, Brooklyn 1, N. Y.

## Wednesday morning

Registration—9:00 a.m.

*Opening Remarks* by E. Weber, Polytechnic Institute of Brooklyn.

*Introduction* by Chairman, J. G. Truxal, P.I.B.

*Stability Theory,* W. Kaplan, University of Michigan.

*Engineering Applications of Nonlinear Theory,* N. W. MacLachlan, Pennsylvania State University.

*Switching and Discontinuous Systems,* R. Bellman, The Rand Corporation.

## Wednesday afternoon

### DESIGN OF NONLINEAR CIRCUITS

*Chairman:* H. J. Carlin, P.I.B.

*Multiple-mode Oscillators and Distributed Systems,* W. A. Edson, Microwave Laboratory, General Electric Co., Palo Alto, Calif.

*Amplitude Stabilization of Oscillators by Nonlinear Resistors,* M. H. Graham, Brookhaven National Laboratory.

*Initial Conditions for Certain Types of Nonlinear Oscillations,* C. Hayashi, Massachusetts Institute of Technology and Kyoto University, Kyoto, Japan.

*Subharmonic Response of Ferromagnetic Circuits,* E. Brenner, The College of the City of N. Y.

*Analysis of Self-saturating Magnetic Amplifiers Considering the Change of the Width of the Dynamic Hysteresis Loop,* T. Kikuchi, Tohoku University, Japan.

## Thursday morning

### NONLINEAR FEEDBACK SYSTEMS

*Chairman:* J. R. Ragazzini, Columbia University.

*A Practical Method of Producing Describing Functions for Nonlinear Circuits,* K. Klotter, Stanford University.

*Equivalent Linearization,* R. W. Bass, Princeton University.

*A Servo with Linear Operation in a Region About the Optimum Discontinuous Switching Curve,* L. L. Rauch and R. M. Howe, University of Michigan.

*Feedback Control Systems with Nonlinear Comparators,* J. M. Ham and W. Fraser, University of Toronto, Toronto, Canada.

*Piecewise Linear Analysis and Synthesis,* T. E. Stern, Research Laboratory of Electronics, Massachusetts Institute of Technology.

## Thursday afternoon

### DISCONTINUOUS SYSTEMS AND SYSTEMS WITH RANDOM INPUTS

*Chairman:* R. Bellman, The Rand Corporation.

*Mean-Square Optimization Theory for Nonlinear Systems,* R. C. Booton, Jr., Massachusetts Institute of Technology.

*On the Distribution of Nonlinear Circuit Transformations of a Markov Process*, R. Deutsch, Hughes Aircraft Co.

*Digital Computers in the Synthesis of Nonlinear Feedback Systems*, J. R. Burnett, Purdue University.

*On-Off Controlled Higher-Order Systems*, B. Hamel, Société Française d'équipements pour la Navigation Aérienne, Paris, France.

*Nonlinear Aspects of Sampled-Data Control Systems*, R. E. Kalman, Columbia University.

*On the Design of Flip-flops*, L. M. Vallese, Microwave Research Institute, P.I.B.

#### Friday morning

##### METHODS

*Chairman*: N. W. MacLachlan, Pennsylvania State University.

*The Nonlinear Resistive Three-pole: Some General Concepts*, W. Millar, United Kingdom Atomic Energy Authority, Harwell, England.

*General Energy Relations in Nonlinear Networks*, J. M. Manley and H. E. Rowe, Bell Telephone Laboratories.

*Complex Convolution Applied to Nonlinear Analysis*, E. Weber, Polytechnic Institute of Brooklyn.

*Frequency Analysis of Noise Jittered Harmonic Generation Systems*, M. J. DiToro, Polytechnic Research and Development Corp.

*Frequency Conversion with Positive Nonlinear Resistors*, C. H. Page, National Bureau of Standards.

#### Friday afternoon

*Theory and Practice*—Practical Evaluation of Methods in Nonlinear Circuit Theory—round table discussion.

*Moderator*: E. Weber, Polytechnic Institute of Brooklyn.



## FOURTH ANNUAL SEMICONDUCTOR SYMPOSIUM

MARK HOPKINS HOTEL, SAN FRANCISCO, CALIFORNIA  
PEACOCK COURT, LOBBY FLOOR

APRIL 29–MAY 3, 1956

The Fourth Annual Semiconductor Symposium of the Electrochemical Society will be held at the Mark Hopkins Hotel, San Francisco, California, April 29–May 3. The program will be divided into two half-day sessions on semiconducting materials, a half-day session on surface controlled phenomena, and a half-day session on chemical process technology.

An integral part of the program will be the presentation of "recent news" papers, not longer than a half hour in length. Persons desiring to submit such papers should contact J. W. Faust, Jr., Westinghouse Research Laboratories, Beulah Road, Churchill Borough, Pittsburgh 35, Pennsylvania, as soon as possible, giving title or general area of interest. 75-word abstracts of these papers must be sent to Mr. Faust before April 1. Mimeographed copies of these abstracts will be available at the registration desk.

J. W. Faust, Jr. is Program Chairman. Chairmen presiding over the four sessions are: G. K. Teal, *Elemental Semiconductors*; A. Beer, *Semiconducting Alloys and Compounds*; H. Q. North, *Process Technology*; and A. E. Middleton, *Surface Controlled Phenomena*. The keynote speaker will be John Bardeen of the University of Illinois. Other guest speakers will be H. Y. Fan, F. J. Biondi, and E. M. Clarke.

Wednesday, May 2

9:00 a.m.

#### ELEMENTAL SEMICONDUCTORS

Introductory Remarks by J. W. Faust.

*Surface States on Semiconductors* by J. Bardeen, Univ. of Illinois, Urbana, Ill.

*Elemental Semiconductors* by H. Y. Fan, Purdue University, Lafayette, Ind.

*Defects in Crystals of Silicon and Germanium Grown from the Melt* by E. Billig, Associated Electrical Industries, Aldermaston, England.

*Rectifying Semiconductor Contacts—A Review of Theoretical Progress* by H. K. Henisch, Sylvania Electric Products, Bayside, N. Y.

*The Distribution of Copper between Germanium and Ternary Melts Saturated with Germanium* by C. D. Thurmond and R. A. Logan, Bell Telephone Labs., Murray Hill, N. J.

2:00 p.m.

#### SEMICONDUCTING ALLOYS AND COMPOUNDS

*Conductivity and Band Gap Measurements of Some Relatives of Phthalocyanine* by W. Felmeier and I. Wolf, General Electric Co., Syracuse, N. Y.

*Ternary Compound Semiconductors with the Chalcopyrite Structure* by I. G. Austin, C. H. I. Goodman and A. E. S. Pengelly, The General Electric Co., Ltd., Wembley, England.

*Electronic and Ionic Fluctuation Processes in Semiconductors* by R. E. Burgess, University of British Columbia, Canada.

*Influence of the Absorption Edges of Cadmium and Silver on the X-Ray Diffraction Pattern of Cadmium Compounds* by R. J.

Robinson and F. Schossberger, Armour Research Foundation, Chicago, Ill.

"Recent News" papers.

Thursday, May 3

9:00 a.m.

#### PROCESS TECHNOLOGY

*The Status of Semiconductor Technology* by F. J. Biondi, Bell Telephone Labs, Murray Hill, N. J.

*A Metal-Semiconductor Capacitor* by R. L. Taylor and H. E. Haring, Bell Telephone Labs, Murray Hill, N. J.

*A Design of Diffused Junction Silicon Diodes* by H. S. Veloric and K. D. Smith, Bell Telephone Labs, Murray Hill, N. J.

"Recent News" papers.

12:30 p.m.

#### Room to be announced

Electronics Division luncheon and business meeting

2:00 p.m.

#### SURFACE CONTROLLED PHENOMENA

*Some Applications of Field Effect Studies on Germanium Surface* by E. N. Clarke, Sylvania Electric Products, Bayside, N. Y.

*Anodic Oxidation of Silicon* by P. F. Schmidt, Philco Corp., Philadelphia, Pa.

*Anodic Oxide Films on Germanium* by S. Zwerdling and S. Sheff, Lincoln Laboratory, M.I.T., Cambridge, Mass.

"Recent News" papers.

# Professional Groups†

**Aeronautical & Navigational Electronics**—James L. Dennis, General Technical Films, 3005 Shroyer, Dayton, Ohio.  
**Antennas & Propagation**—Delmer C. Ports, Jansky & Bailey, 1339 Wisconsin Ave., N.W., Washington 7, D. C.  
**Audio**—W. E. Kock, Bell Tel. Labs., Murray Hill, N. J.  
**Automatic Control**—Robert B. Wilcox, Raytheon Manufacturing Co., 148 California St., Newton 58, Mass.  
**Broadcast & Television Receivers**—L. R. Fink, Research Lab., General Electric Company, Schenectady, N. Y.  
**Broadcast Transmission Systems**—O. W. B. Reed, Jr., Jansky & Bailey, 1735 DeSales St., N.W., Washington, D. C.  
**Circuit Theory**—H. J. Carlin, Microwave Res. Inst., Polytechnic Inst. of Brooklyn, 55 Johnson St., Brooklyn 1, N. Y.

† Names listed are Group Chairmen.

**Communications Systems**—A. C. Peterson, Jr., Bell Labs., 463 West St., New York 14, N. Y.  
**Component Parts**—A. W. Rogers, Electronic Parts & Materials Branch, Signal Corps Engineering Labs., Fort Monmouth, N. J.  
**Electron Devices**—J. S. Saby, Electronics Laboratory, G.E. Co., Syracuse, N. Y.  
**Electronic Computers**—J. H. Felker, Bell Labs., Whippany, N. J.  
**Engineering Management**—Max Batsel, Engineering Products Dept., RCA Victor Div. Bldg. 10-7, Camden, N. J.  
**Industrial Electronics**—George P. Bosomworth, Engrg. Lab., Firestone Tire & Rubber Co., Akron 17, Ohio  
**Information Theory**—Louis A. DeRosa, Federal Telecommunications Lab., Inc., 500 Washington Avenue, Nutley, N. J.  
**Instrumentation**—F. G. Marble, Boonton Radio Corporation, Intervale Road, Boonton, N. J.

**Medical Electronics**—V. K. Zworykin, RCA Labs., Princeton, N. J.  
**Microwave Theory and Techniques**—A. C. Beck, Box 107, Red Bank, N. J.  
**Military Electronics**—C. L. Engleman, 2480 16 St., N.W., Washington 9, D. C.  
**Nuclear Science**—M. A. Schultz, Westinghouse Elec. Corp., Commercial Air Power, P.O. Box 355, Pittsburgh 30, Pa.  
**Production Techniques**—R. R. Batcher, 240-02—42nd Ave., Douglaston, L. I., N. Y.  
**Reliability and Quality Control**—Victor Wouk, Beta Electric Corp., 333 E. 103rd St., New York 29, N. Y.  
**Telemetry and Remote Control**—C. H. Hoepfner, Stavid Engineering, Plainfield, N. J.  
**Ultrasonic Engineering**—M. D. Fagen, Bell Labs., Whippany, N. J.  
**Vehicular Communication**—Newton Monk, Bell Labs., 463 West St., N. Y., N. Y.

# Sections\*

**Akron (4)**—H. L. Flowers, 2029—19 St., Cuyahoga Falls, Ohio; H. F. Lanier, 49 West Lowell Ave., Akron, Ohio.  
**Alberta (8)**—J. W. Porteous, Alberta Univ., Edmonton, Alta., Canada; J. G. Leitch, 13024—123A Ave., Edmonton, Alta., Canada.  
**Albuquerque-Los Alamos (7)**—T. G. Banks, Jr., 1124 Monroe St., S.E., Albuquerque, N. Mex.; G. A. Fowler, 3333—49 Loop, Sandia Base, Albuquerque, N. Mex.  
**Atlanta (3)**—D. L. Finn, School of Elec. Engr'g., Georgia Inst. of Tech., Atlanta, Ga.; P. C. Toole, 605 Morningside Dr., Marietta, Ga.  
**Baltimore (3)**—C. F. Miller, Johns Hopkins University, 307 Ames Hall, Baltimore 18, Md.; H. R. Hyder, 3rd, Route 2, Owings Mills, Md.  
**Bay of Quinte (8)**—J. C. R. Punched, Elec. Div., Northern Elec. Co. Ltd., Sydney St., Belleville, Ont., Canada; M. J. Walker, R.R. 1, Foxboro, Ont., Canada.  
**Beaumont-Port Arthur (6)**—W. W. Eckles, Jr., Sun Oil Company, Prod. Laboratory, 1096 Calder Ave., Beaumont, Tex.; E. D. Coburn, Box 1527, Beaumont, Tex.  
**Binghamton (4)**—O. T. Ling, 100 Henry Street, Binghamton, N. Y.; Arthur Ham-burgen, 926 Glendale Dr., Endicott, N. Y.  
**Boston (1)**—T. P. Cheatham, Jr., Hosmer St., Marlborough, Mass.; R. A. Waters, 4 Gordon St., Waltham, Mass.  
**Buenos Aires**—J. M. Rubio, Ayacucho 1147, Buenos Aires, Argentina; J. L. Blon, Transradio Internacional, San Martin 379, Buenos Aires, Argentina.  
**Buffalo-Niagara (1)**—D. P. Welch, 859 Highland Ave., Buffalo 23, N. Y.; W. S. Holmes, 1961 Ellicott Rd., West Falls, N. Y.  
**Cedar Rapids (5)**—Ernest Pappenfus, 1101—30 St. Dr., S.E., Cedar Rapids, Iowa; E. L. Martin, 3821 Vine Ave., S.E., Cedar Rapids, Iowa.

**Central Florida (3)**—K. A. West, 1345 Indian River Dr., Eau Gallie, Fla.; K. M. Aitken, Box 192, Merritt Island, Fla.  
**Chicago (5)**—J. S. Brown, 9829 S. Hoyne Ave., Chicago 43, Ill.; D. G. Haines, 17 West 121 Oak Lane, Bensenville, Ill.  
**China Lake (7)**—B. B. Jackson, 54-B Rowe St., China Lake, Calif.; H. W. Rosenberg, 217-B Fowler St., N.O.T.S., China Lake, Calif.  
**Cincinnati (4)**—D. W. Martin, The Baldwin Company, 1801 Gilbert, Cincinnati 2, Ohio; F. L. Wedig, Jr., 3819 Davenant Ave., Cincinnati 13, Ohio.  
**Cleveland (4)**—R. H. DeLany, 5000 Euclid Ave., Cleveland 3, Ohio; J. F. Keithley, 22775 Douglas Rd., Shaker Heights 22, Ohio.  
**Columbus (4)**—W. E. Rife, 6762 Rings Rd., Amlin, Ohio; R. L. Cosgriff, 2200 Homestead Dr., Columbus, Ohio.  
**Connecticut Valley (1)**—P. F. Ordnung, Dunham Laboratory, Yale University, New Haven, Conn.; H. M. Lucal, Box U-37, University of Connecticut, Storrs, Conn.  
**Dallas (6)**—M. W. Bullock, 6805 Northwood Rd., Dallas 25, Texas; C. F. Seay, Jr., Collins Radio Company, 1930 Hi-Line Dr., Dallas, Texas  
**Dayton (5)**—W. W. McLennan, 304 Schenck Ave., Dayton 9, Ohio; N. A. Nelson, 310 Lewiston Rd., Dayton 9, Ohio.  
**Denver (6)**—J. W. Herbstreit, 2000 E. Ninth Ave., Boulder, Colo.; R. S. Kirby, 455 Hawthorne Ave., Boulder, Colo.  
**Des-Moines-Ames (5)**—A. D. Parrott, 1515—45 St., Des Moines 11, Iowa; W. L. Hughes, E. E. Department, Iowa State College, Ames, Iowa.  
**Detroit (4)**—N. D. Saigeon, 611 Nightingale, Dearborn, Michigan; A. L. Coates, 1022 E. Sixth St., Royal Oak., Mich.  
**Egypt**—H. M. Mahmoud, Faculty of Engineering, Fouad I University, Giza, Cairo, Egypt; E. I. El Khashan, Main E.S.B. Stations, 4, Sherifein, Cairo, Egypt.  
**Elmira-Corning (1)**—R. A. White, 920

Grand Central Ave., Horseheads, N. Y.; R. G. Larson, 220 Lynhurst Ave., Windsor Gardens, Horseheads, N. Y.  
**El Paso (6)**—J. C. Nook, 1126 Cimarron St., El Paso, Texas; J. H. Maury, 3519 Fort Blvd., El Paso, Texas.  
**Emporium (4)**—D. A. Dander, 22 S. Cherry St., Emporium, Pa.; R. J. Bisso, 99 Meadow Rd., Emporium, Pa.  
**Evansville-Owensboro (5)**—R. E. Moe, General Electric Company, 316 E. Ninth St., Owensboro, Ky.; A. K. Miegler, 904 Kelsey Ave., Evansville, Ind.  
**Fort Worth (6)**—G. C. Sumner, 3900 Spurgeon, Fort Worth, Texas; C. W. Macune, 3132 Forest Park Blvd., Fort Worth, Texas.  
**Fort Wayne (5)**—C. L. Hardwick, 2905 Chestnut St., Fort Wayne 4, Ind.; Paul Rudnick, Farnsworth Electronics Company, Fort Wayne 1, Ind.  
**Hamilton (8)**—G. F. Beaumont, 6 Tallman Ave., Burlington, Ont., Canada; C. N. Chapman, 40 Dundas St., Waterdown, Ont., Canada.  
**Hawaii (7)**—H. E. Turner, 44—271 Mikiola Dr., Kaneohe, Hawaii; G. H. Hunter, Box 265, Lanikai, Oahu, T. H.  
**Houston (6)**—L. W. Erath, 2831 Post Oak Rd., Houston, Texas; R. W. Olson, Box 6027, Houston 6, Texas.  
**Huntsville (3)**—A. L. Bratcher, 308 E. Holmes St., Huntsville, Ala.; W. O. Frost, Box 694, Huntsville, Ala.  
**Indianapolis (5)**—A. J. Schultz, 908 E. Michigan St., Indianapolis, Ind.; H. L. Wisner, 5418 Rosslyn Ave., Indianapolis 20, Ind.  
**Israel**—Franz Ollendorf, Box 910, Hebrew Inst. of Technology, Haifa, Israel; Moshe Tkatch, Box 7063, Hakyria, Tel-Aviv, Israel.  
**Ithaca (1)**—Benjamin Nichols, School of Electrical Engineering, Cornell University, Ithaca, N. Y.; H. L. Heydt, General Electric Advanced Electronics Center, Cornell University Airport, Ithaca, N. Y.

(Cont'd on next page)

\* Numerals in parentheses following Section designate Region number. First name designates Chairman, second name, Secretary.

*(Sections cont'd)*

- Kansas City (6)**—Richard W. Fetter, 8111 W. 87 St., Overland Park, Kan.; Mrs. G. L. Curtis, Radio Industries, Inc., 1307 Central Ave., Kansas City 2, Kan.
- Little Rock (6)**—J. E. Wylie, 2701 N. Pierce, Little Rock, Ark.; D. L. Winn, Tenth and Spring Sts., Little Rock, Ark.
- London (8)**—C. F. MacDonald, 328 St James St., London, Ont., Canada; J. D. B. Moore, 27 McClary Ave., London, Ont., Canada.
- Long Island (2)**—Paul G. Hansel, Addison Lane, Greenvale, L. I., N. Y.; W. P. Frantz, Sperry Gyroscope Co., Great Neck, L. I., N. Y.
- Los Angeles (7)**—Walter E. Peterson, 4016 Via Cardelina, Palos Verdes Estates, Calif.; John K. Gossland, 318 E. Calaveras St., Altadena, Calif.
- Louisville (5)**—O. W. Towner, WHAS Inc., 525 W. Broadway, Louisville 2, Ky.; L. A. Miller, 314 Republic Bldg., Louisville 2, Ky.
- Lubbock (6)**—H. A. Spuhler, Electrical Engineering Department, Texas Technological College, Lubbock, Texas; J. W. Dean, 1903—49 St., Lubbock, Texas.
- Miami (3)**—C. S. Clemans, Station WSWN, Belle Glade, Fla.; H. F. Bernard, 1641 S.W. 82 Place, Miami, Fla.
- Milwaukee (5)**—Alex Paalu, 1334 N. 29 St., Milwaukee 8, Wis.; J. E. Jacobs, 6230 S. 116 St., Hales Corner, Wis.
- Montreal (8)**—Sydney Bonneville, Room 1427, 1050 Beaver Hall Hill, Montreal, Que., Canada; R. E. Penton, 2090 Claremont Ave., N.D.G., Montreal, Que., Canada.
- Newfoundland (8)**—E. D. Witherstone, 6 Cornell Heights, St. John's, Newfoundland, Canada; R. H. Bunt, Box H-182, St. John's, Newfoundland, Canada.
- New Orleans (6)**—J. A. Cronvich, Dept. of Electrical Engineering, Tulane University, New Orleans 18, La.; N. R. Landry, 620 Carol Dr., New Orleans 21, La.
- New York (2)**—A. C. Beck, Box 107, Red Bank, N. J.; J. S. Smith, 506 East 24 St., Brooklyn 10, N. Y.
- North-Carolina-Virginia (3)**—J. C. Mace, 1616 Jefferson Park Ave., Charlottesville, Va.; A. L. Comstock, 1404 Hampton Drive, Newport News, Va.
- Northern New Jersey (2)**—P. S. Christaldi, Box 111, Clifton, N. J.; W. C. Moore, 130 Laurel Hill Rd., Mountain Lakes, N. J.
- Northwest Florida (3)**—B. H. Overton, Box 115, Shalimar, Fla.; G. C. Fleming, 579 E. Gardner Dr., Ft. Walton Beach, Fla.
- Oklahoma City (6)**—A. P. Challenner, University of Oklahoma, Norman, Oklahoma; Frank Herrmann, 1913 N.W. 21 St., Oklahoma City, Okla.
- Omaha-Lincoln (5)**—M. L. McGowan, 5544 Mason St., Omaha 6, Neb.; C. W. Rook, Dept. of Electrical Engineering, University of Nebraska, Lincoln 8, Neb.
- Ottawa (8)**—George Gliniski, 36 Granville Ave., Ottawa, Ont., Canada; C. F. Patenson, 3 Braemar, Ottawa 2, Ont., Canada.
- Philadelphia (3)**—C. R. Kraus, Bell Telephone Co. of Pa., 1835 Arch St., 16 Floor, Philadelphia 3, Pa.; Nels Johnson, Philco Corp., 4700 Wissahickon Ave., Philadelphia 44, Pa.
- Phoenix (7)**—W. R. Saxon, 641 E. Missouri, Phoenix, Ariz.; G. L. McClanathan, 509 East San Juan Cove, Phoenix, Ariz.
- Pittsburgh (4)**—J. N. Grace, 112 Heather Dr., Pittsburgh 34, Pa.; J. B. Woodford, Jr., Box 369, Carnegie Tech. P.O., Pittsburgh 13, Pa.
- Portland (7)**—J. M. Roberts, 4325 N.E. 77, Portland 13, Ore.; D. C. Strain, 7325 S. W. 35 Ave., Portland 19, Ore.
- Princeton (2)**—G. C. Sziklai, Box 3, Princeton, N. J.; L. L. Burns, Jr., R.C.A. Labs., Princeton, N. J.
- Rochester (1)**—G. H. Haupt, 48 Van Voorhis Ave., Rochester 17, N. Y.; B. L. McArdle, Box 54, Brighton Sta., Rochester 10, N. Y.
- Rome-Utica (1)**—H. F. Mayer, 60 Fountain St., Clinton, N. Y.; R. S. Grisetti, 67 Root St., New Hartford, N. Y.
- Sacramento (7)**—R. C. Bennett, 3401 Chenu Ave., Sacramento 21, Calif.; R. A. Poucher, Jr., 3021 Mountain View Ave., Sacramento 21, Calif.
- St. Louis (6)**—F. A. Fillmore, 5758 Itaska St., St. Louis 9, Mo.; Christopher Efthim, 1016 Louisville Ave., St. Louis 10, Mo.
- Salt Lake City (7)**—A. L. Gunderson, 3906 Parkview Dr., Salt Lake City, Utah; S. B. Hammond, Engineering Hall, Univ. of Utah, Salt Lake City 1, Utah.
- San Antonio (6)**—Paul Tarrodaychik, 215 Christine Dr., San Antonio 10, Texas; J. B. Porter, 647 McIlvaine St., San Antonio 1, Texas.
- San Diego (7)**—F. X. Brynes, 1759 Beryl St., San Diego 9, Calif.; R. T. Silberman, 4274 Middlesex Dr., San Diego, Calif.
- San Francisco (7)**—B. M. Oliver, 275 Page Mill Rd., Palo Alto, Calif.; Wilson Pritchett, Div. of Electrical Engineering, University of California, Berkeley 4, Calif.
- Schenectady (1)**—C. C. Allen, 2064 Baker Ave., Schenectady 9, N. Y.; A. E. Rankin, 833 Whitney Dr., Schenectady, N. Y.
- Seattle (7)**—W. C. Galloway, 5215 Pritchard St., Seattle 6, Wash.; J. M. Scovill, 7347—58 Ave., N.E., Seattle 15, Wash.
- Syracuse (1)**—G. M. Glasford, Electrical Engineering Dept., Syracuse University, Syracuse 10, N. Y. (Secretary).
- Tokyo**—Officers to be elected.
- Toledo (4)**—L. R. Klopfenstein, Portage, Ohio; D. F. Cameron, 1619 Milburn Ave., Toledo 6, Ohio.
- Toronto (8)**—A. P. H. Barclay, 2 Pine Ridge Dr., Toronto 13, Ont., Canada; H. W. Jackson, 352 Laird Dr., Toronto 17, Ont., Canada
- Tulsa (6)**—Glen Peterson, 502 S. 83 East Ave., Tulsa, Okla.; D. G. Egan, Research Laboratory, Carter Oil Company, Box 801, Tulsa 2, Okla.
- Twin Cities (5)**—N. B. Coil, 1664 Thomas Ave., St. Paul 4, Minn.; A. W. Sear, 5801 York Ave. S., Minneapolis 10, Minn.
- Vancouver (8)**—J. E. Breeze, 5591 Toronto Rd., Vancouver 8, B. C., Canada; R. A. Marsh, 3873 W. 23 Ave., Vancouver, B. C., Canada.
- Washington (3)**—H. I. Metz, U. S. Government Dept. of Commerce, CAA, Room 2076, T-4 Bldg., Washington 25, D. C.; R. M. Page, 5400 Branch Ave., Washington 23, D. C.
- Williamsport (4)**—G. B. Amey, 968 N. Market St., Williamsport, Pa.; W. H. Bresee, 818 Park Ave., Williamsport, Pa.
- Winnipeg (8)**—R. M. Simister, 179 Renfrew St., Winnipeg, Man., Canada; G. R. Wallace, 400 Smithfield Ave., Winnipeg, Man., Canada.

## Subsections

- Berkshire (1)**—Gilbert Devey, Sprague Electric Company, Marshall St., Bldg. 1, North Adams, Mass.; R. P. Sheehan, Ballou Lane, Williamstown, Mass.
- Buenaventura (7)**—W. O. Bradford, 301 East Elm St., Oxnard, Calif.; M. H. Fields, 430 Roderick St., Oxnard, Calif.
- Centre County (4)**—W. L. Baker, 1184 Omeida St., State College, Pa.; W. J. Leiss, 1173 S. Atherton St., State College, Pa.
- Charleston (3)**—W. L. Schachte, 152 Grove St., Charleston 22, S. C.; Arthur Jonas, 21 Madden Dr., Dorchester Terr., Charleston Heights, S. C.
- East Bay (7)**—J. M. Rosenberg, 1134 Norwood Ave., Oakland 10, Cal.; C. W. Park, 6035 Chabolyn Terrace, Oakland, Cal.
- Erie (1)**—R. S. Page, 1224 Idaho Ave., Erie 10, Pa.; R. H. Tuznik, 905 E. 25 St., Erie, Pa.
- Fort Huachuca (7)**—R. O. Burns, Army Electronic Proving Ground, Ft. Huachuca, Ariz.; J. H. Homsy, Box 123, San Jose Branch, Bisbee, Ariz.
- Lancaster (3)**—R. B. Janes, Radio Corporation of America, Tube Dept., Lancaster, Pa.; H. F. Kazanowski, 108 Mackin Ave., Lancaster, Pa.
- Mid-Hudson (2)**—R. E. Merwin, 13 S. Randolph Ave., Poughkeepsie, N. Y.; P. A. Bunyar, 10 Morris St., Saugerties, N. Y.
- Monmouth (2)**—G. F. Senn, Orchard Rd.-River Plaza, Red Bank, N. J.; C. A. Borgeson, 82 Garden Rd., Little Silver, N. J.
- Orange Belt (7)**—F. D. Craig, 215 San Rafael, Pomona, Calif.; W. F. Meggers, Jr., 6844 De Anza Ave., Riverside, Calif.
- Palo Alto (7)**—W. W. Harman, Electronics Research Laboratory, Stanford University, Stanford, Calif.; W. G. Abraham, 611 Hansen Way, c/o Varian Associates, Palo Alto, Calif.
- Pasadena (7)**—Jennings David, 585 Rim Rd., Pasadena 8, Calif. (Secretary).
- Piedmont**—Officers to be elected.
- Quebec (8)**—Maurice Boisvert, 1340 De Buisson, Sillery, P. Q., Canada; G. J. E. Fortin, 57 Fraser St., Quebec 6, P. Q., Canada.
- Richland (7)**—R. G. Clark, 1732 Howell, Richland, Washington; R. E. Connally, 515 Cottonwood Dr., Richland, Wis.
- Tucson (7)**—R. C. Eddy, 5211 E. 20 St., Tucson, Ariz.; P. E. Russell, Elect. Eng. Dept., Univ. Ariz., Tucson, Ariz.
- USAFIT (5)**—J. J. Gallagher, Box 3482 USAFIT, Wright-Patterson AFB, Ohio (Secretary).
- Westchester County (2)**—Joseph Reed, 52 Hillcrest Ave., New Rochelle, N. Y.; D. S. Kellogg, 9 Bradley Farms, Chappaqua, N. Y.
- Wichita (6)**—M. E. Dunlap, 548 S. Lorraine Ave., Wichita 16, Kan.; English Piper, 1838 S. Parkwood Lane, Wichita, Kan.

# Abstracts of IRE Transactions

The following issues of "Transactions" have recently been published, and are now available from the Institute of Radio Engineers, Inc., 1 East 79th Street, New York 21, N. Y. at the following prices. The contents of each issue and, where available, abstracts of technical papers are given below.

Sponsoring Group	Publication	Group Members	IRE Members	Non-Members*
Antennas and Propagation	Vol. AP-3, No. 4	\$2.10	\$3.15	\$6.30
Broadcast and Television Receivers	Vol. BTR-1, No. 4	\$0.95	\$1.40	\$2.85
Broadcast Transmission Systems	PGBTS-2	\$1.20	\$1.80	\$3.60
Broadcast Transmission Systems	PGBTS-3	\$2.10	\$3.15	\$6.30
Microwave Theory and Techniques	Vol. MTT-3, No. 6	\$1.75	\$2.60	\$5.25

\* Public libraries and colleges may purchase copies at IRE Member rates.

## Antennas & Propagation

VOL. AP-3, NO. 4, OCTOBER, 1955

### News and Views

**Prediction of Oceanic Duct Propagation from Climatological Data**—L. J. Anderson and E. E. Gossard

Techniques are described for predicting the effect of the "oceanic duct" in increasing the coverage of low-sited microwave radars. Prediction is made on a monthly basis using statistical data on sea temperature, air temperature, humidity, and wind speed. A large area in the northwest Pacific is used to illustrate the methods used. The basic prediction approach is to deduce refractive index profiles from available data parameters and to use Schelkunoff's ducting criteria to predict radar propagation effects. Monthly contours are then drawn over the area for each radar band showing the probability of extended coverage.

**The Curved Passive Reflector**—E. Bedrosian

The curved passive reflector is analyzed theoretically by the aperture-field method and the results are presented in the form of gain characteristics and radiation patterns. It is seen that curving the reflector produces a focusing effect in addition to the basic diffraction phenomenon, thereby providing increased gain as compared with the flat reflector. The limiting value for the flat reflector gain is 6 db while the gain of the curved reflector increases continually with reflector size when properly illuminated. Radiation patterns are computed and it is shown that the effect of reducing tower height is to widen the main lobe and to move the side lobes outward and depress them. It is concluded that, in general, the curved reflector causes lower side lobes than the flat reflector. The dish illumination is shown to be relatively unimportant with respect to the total antenna gain but the side lobe levels are reduced when the dish illumination is made more uniform.

**A Multiple Telemetering Antenna System for Supersonic Aircraft**—R. E. Anderson, C. J. Dorrenbacher, R. Krausz, and D. L. Margerum

The existing angle-of-attack indicator spike and ram-pressure tubes on a high-speed aircraft are modified to permit their use as telemetering antenna elements. The antenna system utilizing these elements provides for operation of three airborne telemetering transmitters. Operation of each transmitter and its antenna is independent of damage to or malfunction of the other components in the system, and no multiplexing loss is suffered in the antenna system.

to the vicinity of the antenna elements, antenna performance would be little affected by variations in configuration of aircraft with similar basic design, and direct adaptation of this system to other aircraft of this type, therefore, is relatively straightforward.

**Measurement of Electric Field Distributions**—R. Justice and V. H. Rumsey

The usual method of measuring electric field distributions comprises a receiving antenna at the point of observation, connected by means of a transmission line to receiving apparatus at some distant point. The principal advantage of the method described here is that it eliminates the transmission line and thus makes possible many measurements which cannot be done by the usual method. It is based on the fact that the echo from a thin straight conducting wire is proportional to the square of the component of electric field parallel to the wire. The practical application at centimeter wavelengths is described. The method has proven most valuable in a variety of problems involving flush mounted directional antennas, radomes, artificial transmission lines, etc.

**Determining the Reflector Surface of a Radar Antenna with Point Source Feed**—Pentti Laasonen

In the construction of a radar antenna the basic problem is to give the antenna reflector such a design that the scattering pattern will conform to the required power distribution. An approximative method is given for the determining of the central section of a reflector with point source feed and enveloping the osculating paraboloids, as well as a formula for the computation of the beam reflected by this surface. The central section obtained may be improved successively until adequate accuracy is attained. The method of computation is illustrated by an example.

**Multipath Phase Errors in CW-FM Tracking Systems**—T. E. Sollenberger

High-precision, cw, missile-tracking systems are subject to multipath errors due to ground reflections and reflections from neighboring objects. To reduce the effects of ground reflection, advantage may be taken of the characteristics of frequency modulation to discriminate against a weaker interfering signal. This paper discusses the magnitude of the phase error reduction to be obtained by use of frequency modulation.

It is demonstrated that the phase error can be reduced to any desired value if sufficient bandwidth is utilized in the frequency modulation signal and significant improvement over an amplitude modulation system can be obtained

**Application of the Reaction Concept to Scattering Problems**—M. H. Cohen

Rumsey's "reaction concept" is applied to scattering problems by considering volume polarization currents which generate the scattered field. The scattering cross section is discussed. Approximation formulas are developed and illustrated by calculations for the echo width of a circular cylinder as a function of dielectric constant. Calculations are made for four plane-wave type trial fields in the cylinder; these are compared with the exact solution and with integral equation solutions through the second order. In this case the reaction method gives better results than the integral equation method, for the same amount of labor.

**Radiation Patterns of Slotted-Elliptic Cylinder Antennas**—J. Y. Wong

An expression is developed for the radiation pattern of an array of thin axial slots arbitrarily disposed around the circumference of an elliptic cylinder. Calculated azimuthal patterns are presented for single slots on elliptic cylinders of vanishing thickness. The results can be applied to approximate the pattern of practical cylinders having very thin cross sections.

**The Transmission-Line Properties of a Round Wire between Parallel Planes**—H. A. Wheeler

A transmission line is useful as a primary standard of impedance if there is a formula relating its wave resistance to its cross sectional shape. For this purpose, the round wire between parallel planes is computed to a very close approximation. The method is based on dividing the usual single pole into a pair of spaced half-poles, between parallel lines on the plane of cross section. The resulting formula covers all shape ratios to a high degree of approximation. Simple explicit formulas are given for the shape ratio and the wave resistance, each in terms of the other, sufficiently close for practical purposes. For example, a line made of perfect conductors (assumed) and air dielectric (laboratory conditions), has a wave resistance of  $50.000 \pm 0.003$  ohms if the ratio of radii is 0.54850 =  $1/1.82315$ .

**Current Distribution on Wing-Cap and Tail-Cap Antennas**—Irene Carswell

Surface current distributions on aircraft are examined for wing-cap and tail-cap antennas in the hf band using scale models. Current paths involved in structural resonances are investigated, and the effect of such resonances on antenna impedance is discussed. Measured results are also applied to the interpretation of radiation patterns.

A technique is described for measuring the relative amplitude and phase of the surface current, and for determining the direction of current flow. In this method the detector is placed in the model and the probe is driven by an external source of rf power. This technique permits the frequency to be changed easily. The system is more sensitive than others described in the literature, since a higher power source can be used when it is not required to be enclosed in the aircraft model.

**Communications—Note on a Method for Calculating Coupling Coefficients of Elements in Antenna Arrays**—V. T. Norwood

**On-Axis Defocus Characteristics of the Paraboloidal Reflector**—D. K. Cheng and S. T. Moseley

Lack of an adequate test site often requires the use of on-axis defocusing to obtain simulated Fraunhofer radiation patterns in the optical-Fresnel region from microwave reflector-type antennas. This note presents a way of determining the required amount of defocus from the viewpoint of aperture phase correction. It is shown that the important part of the main lobe of the radiation pattern can be approximately reproduced in the optical-Fresnel region with proper amount of defocus. For a given

beam-width with the position of the primary source can also be predicted.

**Available Bandwidth in 200-Mile VHF Tropospheric Propagation**—L. A. Ames and T. F. Rogers

**Bibliography of Nonuniform Transmission Lines**—H. Kaufman

**Microwave Optics—Part I: Report on Microwave Optics**—R. C. Spencer

**Part II: Diffraction Problems of Microwave Optics**—H. Bremmer

**Part III: Recent Researches on the Foundations of Geometric Optics and Related Investigations in Electro-magnetic Theory**—E. Wolf

## Broadcast Transmission Systems

PGBTS-2, DECEMBER, 1955

*(Papers Presented at the Third Annual Broadcast Symposium, Philadelphia, Pennsylvania, November 16, 1953)*

**Television Station Construction**—Bernard Eichwald

**Power Amplifiers for Television**—G. E. Hamilton

**One Kilowatt UHF Television Transmitter**—T. P. Tissot and W. N. Wylde

**Performance of Sectionalized Broadcasting Towers**—C. E. Smith, D. B. Hutton and W. G. Hutton

With a sectionalized tower high angle radiation can be minimized to give better ground wave performance than is possible with a simple vertical radiator. A study of theoretical conditions in conjunction with physical limitations reveals that it is necessary to maximize the current distribution on any given tower construction to obtain the maximum ground plane field intensity. Several sectionalized towers and a variety of current distributions on each tower are treated theoretically and tested experimentally. The results obtained are compared with the findings of several other writers treating similar problems.

**Dual-Frequency Operation of a Loaded Vertical Medium-Frequency Radiator**—A. J. McKenzie, W. H. Hatfield, and V. F. Kenna

A method is described for loading a vertical broadcasting aerial for optimum operation at two different frequencies. The design construction and adjustment of a radiator of this type for the Australian National System is discussed in detail.

**A Precision Deflection Yoke**—H. J. Benzuly

A deflection yoke for an image-orthicon was built entirely from printed circuits and operated in a television camera. With the exception of resistance (which for the printed circuit model was much higher) the parameters of a conventional wire-wound yoke were quite readily reproduced, including inductances per coil of as much as 16 millihenries. The use of wider conductors, improved drafting techniques and allowances for undercutting will reduce the resistance to an acceptable value. Furthermore, reasonable care in etching should provide good yield from the printed material, correlation between calculated and measured values, and close tolerances on electrical characteristics. While the experimental work reported here was rather limited in scope, experience with printed coils in other sections of RCA indicate that tolerances of better than 1 per cent inductance and 10 per cent resistance can be realized.

**1955 Directory of Membership—Professional Group on Broadcast Transmission Systems**

PGBTS-3, JANUARY, 1956

*(Papers Presented at the Fifth Annual Fall Symposium of the Professional Group on Broadcast Transmission Systems, Washington, D. C., September 23 and 24, 1955)*

**Address of Welcome**—O. W. B. Reed, Jr.

**Multiple Antenna System for Television Broadcasting with Antennas of Equal Height**—L. J. Wolf

**Studio Switching Problems with Color Signals**—H. W. Morse

**A 50 Kilowatt Television Transmitter**—John Ruston

The development and construction of a new 50 kilowatt television transmitter for use on VHF high band channels 7 to 13 is described. The paper deals primarily with the 50 kilowatt final power amplifier since the 5 kilowatt driver section has been in existence for some time and has been described elsewhere.

The high power amplifier employs a pair of Eimac type 4W20000A tetrode tubes in parallel which have a theoretical maximum peak power capability of about 60 kilowatts when operating as a broadband linear amplifier. This power is readily realized in practice by employing a single quarter wave cavity type output circuit.

The input circuit is designed on the basis of using lumped constants in a quasi grounded cathode circuit and it is shown that with this arrangement it is possible to obtain a wide control of input circuit bandwidth and power gain.

Many mechanical problems were encountered when designing a physical configuration which would include all the necessary dc isolating capacitors, provision for forced air and water cooling, variable adjustments, etc., without appreciably modifying the desired rf circuit. The construction finally adopted is described in some detail and illustrated with diagrams and photographs.

**Integration of Color Television Equipment at WTMJ-TV with Monochrome Facilities**—P. B. Laeser

A discussion of the technical problems arising from the introduction of color TV signals in a broadcast station. An outline of the experience gained by this pioneer station in handling both color network and locally produced color shows during the last twenty months. Of particular interest will be the method and procedures by which WTMJ-TV brought color to an every day station operational level.

**UHF Field Intensity Measurement Experience**—E. W. Chapin

**Present Knowledge of Propagation in the VHF and UHF TV Bands**—W. C. Boese and Harry Fine

Since the Ad Hoc report and the Commission's Sixth Report and Order establishing the present TV allocations, the Commission and others have been collecting measurement data on the propagation of signal at TV frequencies. In many cases data is now available where the earlier studies required extrapolation. It is the purpose of this report to review recent measurements and their analysis as they may affect the service and interference of TV broadcast stations. Reference will be made to areas where additional data and studies are desirable.

**Proof of Performance of Color Television Facilities**—C. X. Castle

**An Investigation by Photographic Simulation of One Type of Bandwidth Reduction of Television Signals**—W. C. Morrison, K. Karstad, James W. Tuska

**Spurious Radiations from TV-AM-FM Broadcast Transmitters**—H. G. Towelson

**The UHF-VHF Allocation Situation**—Fred Weber

**Using New Tape and Film Techniques to Increase TV and Radio Broadcast Operational Efficiency**—R. A. Isberg

Modern professional magnetic tape recorders and reproducers are capable of performing many of the menial chores of radio and TV broadcasting. Pre-recorded announcements accompanied by subaudible tones can control the operation of several tape program reproducers or juke box type automatic record players. Simple systems are available which alternately switch from an announce machine to a program machine, and more elaborate systems include electronic fading and accurate program timing. Many stations use tape only to delay pro-

grams to be broadcast. Two major radio networks in Mexico utilize tape exclusively rather than telephone line interconnections. Some stations have recorded their entire record libraries on tape and utilize simple auxiliary devices for switching from tape to a local live announcer. Their tape recorded programs are varied by interspersing late records.

Attachments are available for standard tape recorders which permit the recording of longitudinal power synchronizing signals simultaneously on the same track with program material. This system affords accurate synchronization (lip sync) of tape reproducers and film printers without the use of sprocket drive systems.

A magnetic film cueing device has been developed which will provide TV station personnel with an easily applied audible cue signal to denote when to switch film projectors. This device will also operate a relay to close doublers, or perform other switching functions.

Systems can be built for utilizing a two channel magnetic tape for recording and reproducing announcements and TV switching sequences. This will permit simplified scheduling of personnel and better utilization of their assigned time, as well as a great reduction in the number of switching operations that are often associated with particular types of local announcements.

**A Novel TV Slide Sequencing Arrangement**—R. E. Peterson

There has long been a need in the television industry for better slide handling and projection. Although the ideal slide projection system is probably yet to be made, we at WNBC-TV feel that we have come fairly close. Starting with a commercially available projector, and adding more elaborate controls and indicators, we have come up with a unit that may be remotely operated from the director's or technical director's position. The use of this projector in the small or medium sized station with proper equipment arrangement can greatly improve slide handling and offers strong possibilities of cutting down on the operating staff needed.

**Some Techniques in Automatic Programming**—E. F. Vandivere, Jr.

A description of some simple techniques in automatic programming provides a practical context in which to list some of the questions and problems that face us in automatic programming.

## Broadcast & Television Receivers

VOL. BTR-1, NO. 4

OCTOBER, 1955

**Automation—Its Impact upon the Electronic Engineer**—D. D. Israel

**An All-Electronic Signal-Seeking Broadcast Receiver**—C. W. Hargens, III

This paper describes a practical signal-seeking receiver which requires no mechanical tuning mechanism. High-frequency saturable reactors are used in the tuning and oscillator circuits, and means for causing the receiver to lock on stations of specified signal strength are described. Several methods for producing tracking between the oscillator and tuning circuits are also discussed. The characteristics of the tuning inductors used are given as well as performance curves for the complete receiver.

**Yoke Development for Standardization of 70° and 90° Deflection Angle**—C. E. Torsch

During the past two years, the American picture tube manufacturers have, through their RETMA and NEMA membership, studied the fundamental standardization of picture tube design in regard to maximum deflection angle, to effectively define 70° and 90° classes of tubes.

The joint Electron Tube Engineering Council of RETMA and NEMA appointed a committee to arrive at a means for testing picture tubes to insure interchangeability of various tube manufacturers' products of a nominal registry type, as to freedom from "neck shadow."

JETEC representatives invited the author (active in both yoke design and tube applica-

tion engineering) to consult in developing test yokes and methods of establishing limiting tube-yoke performance.

Practical tests were conducted by members of JETEC Committee 6 at representative tube factories, on commercial tubes and yokes of the 70° and 90° classes. Final conclusions established a test method and registered a 70° and a 90° reference yoke to be employed in the test for neck shadow, JETEC #118 Yoke and JETEC #119 Yoke, respectively.

The principles involved in establishing test yokes as limiting standards are discussed. The result of this work will enable future tube and yoke designs to be properly evaluated and related to each other—formerly an ambiguous task.

#### VHF-UHF Radiation Measurements—A. B. Glenn

This is a progress report on vhf-uhf radiation measurements by IRE Subcommittee 27.3. The function of this committee is to develop techniques for the measurement of radio interference generated by fm and TV receivers. This radio interference may cover the spectrum from 300 kc to 1,000 mc.

## Microwave Theory & Techniques

VOL. MTT-3, No. 6  
DECEMBER, 1955

### Foreword

#### Wave Coupling by Warped Normal Modes—A. G. Fox

It has been shown by J. S. Cook that wave power may be transferred from one to another of two coupled waveguides through a variation of their phase constants. It is now clear that this is but one example of a new principle of coupling which is here called "normal mode warping." Wave power inserted at one end of a coupled waveguide system may be made to appear at the other end with any desired power distribution by gradual warping of the normal mode field patterns along the coupler. In general, both variation of the coupling coefficient and phase constants are required. Much wider bands are theoretically possible than with any other distributed type of coupler. This principle may be applied to dielectric waveguides, birefringent media, and waveguides containing ferrite, to obtain both reciprocal and nonreciprocal couplers.

#### Investigation of VHF Nonoptical Propagation Between Sardinia and Minorca—J. M. Clara and Albino Antinori

#### Data on the Temperature Dependence of X-Band Fluorescent Lamp Noise Sources—W. W. Mumford and R. L. Schafersman

This paper is concerned primarily with the performance of fluorescent lamps as microwave noise sources at 9,000 mc. In particular, it deals with the temperature dependence of the excess noise ratio of an 8-watt lamp running at a lamp current of 150 ma in a 10° *E*-plane holder. It was found that 1) the bulb temperature is much higher than that with a lamp current of 75 ma encountered in the 90° *H*-plane circuit investigated previously at 4,000 mc, hence the temperature coefficient of excess noise versus waveguide temperature obtained in the 4,000 mc circuit does not apply, 2) anomalous and unreproducible inversions in the temperature coefficient at these higher bulb temperatures have been observed, 3) these anomalies can be avoided by operating the bulb at lower temperatures, 40°C to 50°C, where the lamps appear to be just as uniform and stable and probably just as noisy as they are at 4,000 mc.

#### Phase Shift by Periodic Loading of Waveguide and Its Application to Broad-band Circular Polarization—A. J. Simmons

A rectangular or square waveguide may be loaded periodically by thin capacitive or inductive irises in order to produce phase delay or phase advance, respectively. The amount of phase shift may be calculated with accuracy by

making use of available theoretical values of iris susceptance and of transmission line theory. The phase shifting sections may be designed for low voltage standing-wave ratio (vswr) over a considerable bandwidth.

When a square waveguide capable of supporting two fundamental modes is loaded periodically, the irises act inductively for one mode and capacitively for the other, thus introducing a differential phase shift. This differential phase shift may be made equal to 90°, in order to convert linear to circular polarization. Furthermore such a device may be made, by proper choice of parameters, to yield near-circular polarization over a bandwidth of 1.65:1, because the variation in phase delay for one mode and phase advance for the other tend to compensate each other as the frequency is varied.

Several of these circular polarizers have been built and tested at X band and the measured results of ellipticity and vswr, as well as broad-band performance check with theoretical values quite closely.

#### 900-mc PTM Over-the-Horizon Radio Link—F. J. Altman, R. E. Gray, A. G. Kandoian, and W. Sichelak

#### A Method for the Accurate Measurement of the Noise Temperature Ratio of Microwave Mixer Crystals—R. E. Davis and R. C. Dearle

For the precise measurement of noise temperature ratio of a microwave mixer crystal it is common practice to employ a Roberts coupling network in order to make the *Y* factor independent of crystal conductance. It is shown here that a number of errors are introduced in this method, the chief of which is failure to consider the effect of transit time loading. It is also shown that the use of cathode lead inductance leads to a much improved measurement of noise temperature ratio.

#### Circuit Components in Dielectric Image Lines—D. D. King

Symmetry of dipole mode in a dielectric rod permits use of an image system. By replacing lower half of dielectric and its surrounding field with an image surface, support problem is eliminated. Resulting image provides structural convenience and also has very low loss, provided wave is allowed to occupy a cross section many wavelengths square. In millimeter region this is readily achieved. Possibilities of new types of circuit elements in this image system are explored. Combination of optical and waveguide techniques is a characteristic of resulting components. Properties of several transducers between image line and either rectangular waveguide or coaxial line are described. Attenuators, standing-wave detector, and directional coupler types for image lines are discussed.

#### Applications of the Turnstile Junction—M. A. Meyer and H. B. Goldberg

The Turnstile Junction is a six-terminal pair microwave network, consisting of four coplanar rectangular arms and a circular arm, orthogonal to the rectangular arms, which is excited in two orthogonal TE<sub>1,1</sub> modes.

The characteristics of the network are such that they lend themselves to some very important and unique applications in the microwave field.

Making use of the symmetry conditions and the field division properties of the Junction, this paper describes the operation of the Junction under various conditions, with particular emphasis on the applications to which these characteristics lend themselves.

Some of the applications discussed are:

1. Continuous-wave (cw) duplexing.
2. Generation of elliptical polarizations.
3. Transmitting linear and receiving cross-linear polarizations.
4. Transmitting and receiving linear polarization.
5. Transmitting and receiving circularly polarized waves.
6. Four-way symmetrical power division.
7. Measuring degree of ellipticity of circularly polarized waves.

#### The Ultra-Bandwidth Finline Coupler—S. D. Robertson

The "finline coupler" is a recently developed microwave circuit element with which it has been possible to assemble hybrid junctions, directional couplers, and polarization-selective couplers capable of operating over bandwidths of at least three-to-one in frequency. Constructional details and experimental results are given.

#### Microwave Traveling-Wave Tube Millimicrosecond Pulse Generators—A. C. Beck and G. D. Mandeville

For some time, short pulse techniques have played a useful part in the microwave art. In order to obtain better resolution, equipment for generating and viewing microwave pulses about six millimicroseconds long was developed and described previously. The regenerative pulse generator in that equipment was rather complex and difficult to build and adjust. A much simpler generator of pulses with about the same time duration is now being used. It produces short pulses by properly gating a conventional microwave signal source with a traveling-wave amplifier having suitable transient voltages applied to both its helix and its beam-forming electrode. It is easier to construct and operate, requires fewer components, and gives a more stable output. It can be used at any frequency where a signal source and a traveling-wave amplifier are available. The pulse frequency can be set anywhere within the amplifier bandwidth.

Both generators are described and compared. Equipment for receiving, displaying, and measuring the pulses is also briefly discussed. Pulse shapes and resolutions are shown on oscilloscope photos.

#### E-Plane Forked Hybrid-T Junction—W. K. Kahn

A novel rearrangement of the waveguides of a microwave hybrid-T junction has been investigated. This junction is formed by the intersection of four rectangular waveguides, two of which (conventionally *E* and *H* arms) are mutually perpendicular, cross-polarized, and have their centerlines in one symmetry plane of the junction; the remaining two waveguide arms are formed by symmetric *E*-plane bifurcation of the *E*-arm waveguide extended. This hybrid T possesses special advantages with regard to match and pulse power capacity.

A special test fixture was constructed of 1.122- $\times$ 0.497-inch rectangular waveguide. Experimental design work was carried out over a 12 per cent range of frequencies from 8.5 to 9.6 kmc. The *H*-arm reflection was reduced to 2.6-db standing-wave ratio (swr) by simple shaping of the bifurcating element. Addition of conventional matching elements resulted in maximum reflections, within the above band, of 0.8 and 0.6 db swr in the *H* and *E* arms, respectively.

The ultimate limitation on the *E*-arm power capacity, as fixed by the intensified electric field at the leading (rounded) edge of the center partition, was computed to be 2 db below uniform waveguide. Experimental corroboration has been obtained.

#### A Switch-Detector Circuit—F. S. Coale

Crystal circuit is used wherein switching is accomplished by varying dc voltage across a crystal. Impedance of crystal plus its mount varies from low inductive to high capacitive value. Maximum attenuation frequency of high pass, series *m*-derived filter varies with change of parallel inductance or capacitance. If crystal is placed across parallel capacitance, and its bias varied, input impedance of filter is changed. As a result, attenuation vs frequency characteristics are varied. Operating parameters of switch are: frequency, 500–1,000 mc; bandwidth, 20 mc; switching, > 55 db; average insertion loss, 2 db; switching time, < ¼  $\mu$ sec; bias voltage, between -0.6 and +0.6 volts. This unit finds application in radar jamming problems, as well as a low power modulator for rf signals.

#### Abstracts—The Regeneration of Binary Microwave Pulses—O. E. DeLange.

Noise Measurements in the UHF Range—E. Maxwell and B. J. Leon. Contributors

There is reprinted below the Appendix to Docket No. 9288 of the Federal Communications Commission giving the amended FCC rules governing restricted radiation devices.—*The Editor*

## PART 15—INCIDENTAL AND RESTRICTED RADIATION DEVICES

### SUBPART A—GENERAL

§15.1 *Basis of this Part.* §301 of the Communications Act of 1934, as amended, provides for the control by the Federal Government over all the channels of interstate and foreign radio communication and further provides, in part, that no person shall use or operate apparatus for the transmission of energy, communications or signals by radio when the effects of such operation extend beyond state lines or cause interference with the transmission or reception of energy, communications, or signals, of any interstate or foreign character by radio, except under and in accordance with the Communications Act and a license granted under the provisions of that Act. Restricted and incidental radiation devices emit radio frequency energy on frequencies within the radio spectrum and constitute a source of harmful interference to authorized radio communication services operating upon the channels of interstate and foreign communication unless precautions are taken which will prevent the creation of any substantial amount of such interference.

#### §15.2 *Scope of this Part.*

(a) This part contains rules that set forth the conditions under which the operation of incidental and restricted radiation devices is considered to fall outside the purview of §301 of the Communications Act which specifies when a station license is required as a condition for lawful operation.

(b) No incidental or restricted radiation device which fails to conform to the provisions of this part, or which causes harmful interference, may be operated without a station license. Unless such devices may be operated in accordance with the provisions of some other part of this chapter (see particularly Part 19, Citizens Radio Service), persons wishing to operate such devices in a manner inconsistent with this part will be required to first secure an amendment of the Commission's rules to establish a licensed service providing for such operation and setting forth the technical and other limitations thereof; provided that in appropriate circumstances, when such a petition for rule making has been filed, the Commission may consider, prior to final action thereon, applications for Special Temporary Authorizations to operate stations on a developmental basis where it can be shown that such temporary operation would be in aid of a final determination as to whether the proposed rule should be adopted, and that such temporary operation would otherwise be in the public interest; and provided further that the Commission will, in exceptional situations, consider individual applications for licenses to operate incidental or restricted radiation devices, not conforming to the provisions of this part, where it can be shown that the proposed operation would be in the public interest, that it is for a unique type

of station or for a type of operation which is incapable of establishment as a regular service, and that the proposed operation cannot feasibly be conducted under these rules.

§15.3 *General condition of operation.* Persons operating restricted or incidental radiation devices shall not be deemed to have any vested or recognizable right to the continued use of any given frequency, by virtue of prior registration or certification of equipment. Operation of these devices is subject to the conditions that no harmful interference is caused and that interference must be accepted that may be caused by other incidental or restricted radiation devices, industrial, scientific or medical equipment, or from any authorized radio service.

#### §15.4 *General definitions.*

*Radio frequency energy.* Electromagnetic energy at any frequency in the radio spectrum between 10 kc and 3,000,000 mc.

*Harmful interference.* Any radiation or induction which endangers the functioning of a radio navigation service or of a safety service or obstructs or repeatedly interrupts a radio service operating in accordance with the regulations in Part 2 of this chapter.

*Incidental radiation device.* A device that radiates radio frequency energy during the course of its operation although the device is not intentionally designed to generate radio frequency energy.

*Restricted radiation device.* A device in which the generation of radio frequency is intentionally incorporated into the design and in which the radio frequency energy is conducted along wires or is radiated, exclusive of transmitters which require licensing under other parts of this chapter and exclusive of devices in which the radio frequency energy is used to produce physical, chemical or biological effects in materials and which are regulated under the provisions of Part 18 of this chapter.

§15.5 *Equipment available for inspection.* Any equipment or device subject to the provisions of this part together with any license, certificate, notice of registration or any technical data required to be kept on file by the operator of the device shall be made available for inspection by Commission representatives upon reasonable request.

§15.6 *Information required by the Commission.* The owner or operator of any device subject to this part shall promptly furnish to the Commission or its representative such information as may be requested concerning the operation of the device including a copy of any field strength measurements made by or for the operator of the device.

§15.7 *General requirement for restricted radiation devices.* Unless regulated under

some other subpart of this part, any apparatus which generates a radio frequency electromagnetic field functionally utilizing a small part of such field in the operation of associated apparatus not physically connected thereto and at a distance not greater than  $157,000/F(\text{kc})$  Ft. (equivalent to  $\lambda/2\pi$ ) need not be licensed provided:

(a) That such apparatus shall be operated with the minimum power possible to accomplish the desired purpose.

(b) That the best engineering principles shall be utilized in the generation of radio frequency currents so as to guard against interference to established radio services, particularly on the fundamental and harmonic frequencies.

(c) That in any event the total electromagnetic field produced at any point a distance of  $157,000/F(\text{kc})$  Ft. (equivalent to  $\lambda/2\pi$ ) from the apparatus shall not exceed 15 microvolts per meter.

(d) That the apparatus shall conform to such engineering standards as may from time to time be promulgated by the Commission.

(e) That in the event harmful interference is caused, the operator of the apparatus shall promptly take steps to eliminate the harmful interference.

### SUBPART B—INCIDENTAL RADIATION DEVICES

§15.31 *Operating requirements.* An incidental radiation device shall be operated so that the radio frequency energy that is radiated does not cause harmful interference. In the event that harmful interference is caused, the operator of the device shall promptly take steps to eliminate the harmful interference.

### SUBPART C—RADIO RECEIVERS

§15.61 *Scope of this Subpart.* Radio receivers come within the scope of this subpart insofar as they are restricted radiation devices and generate and radiate radio frequency energy. Typically, these rules apply to superheterodyne receivers in which the oscillator may produce harmful interference. As another example, these rules also regulate television broadcast receivers with respect to the radio frequency energy which is generated by the horizontal sweep circuits and which may cause interference.

§15.62 *Radiation interference limits.* The radiation from all radio receivers that operate (tune) in the range 30 to 890 mc, including frequency modulation broadcast receivers and television broadcast receivers, manufactured after the effective date of this subpart shall not exceed the following field strength limits at a distance of 100 feet or more from the receiver:



Frequency of radiation (mc)	Field Strength (uv/m)
0.45 up to and including 25	See Note 1
Over 25 up to and including 70	32
Over 70 up to and including 130	50
130-174	50-150 (linear interpolation)
174-260	150
260-470	150-500 (linear interpolation)
470-1000	500

Note 1: Pending the development of suitable measurement techniques for measuring the actual radiation in this band the interference capabilities of a receiver in this band will be determined by the measurement of radio frequency voltage between each power line and ground at the power terminals of the receiver. The voltage so measured shall not exceed 100 uv at any frequency between 450 kc and 25 mc inclusive.

Note 2: The Commission will review this table from time to time with a view to reducing the radiation limits as the radio art develops.

Note 3: See also Section 15.69.

#### §15.63 Measurement procedure.

(a) Any measurement procedure acceptable to the Commission may be used to show compliance with the requirements of this subpart. A detailed description of the proposed measurement procedure, including a list of the test equipment to be used, shall be submitted to the Commission when requesting a determination regarding the acceptability of the proposed measurement procedure.

(b) The following methods of measurement are considered acceptable procedures for certification of receivers pursuant to Section 15.64 of this part:

- (1) Institute of Radio Engineers Standard 51 IRE 17S1 for radiation measurements.
- (2) Institute of Radio Engineers Standard 54 IRE 17.S1 for powerline interference measurements for television broadcast receivers, when the standard is modified by substituting a line stabilization network having the electrical constants described in MIL-I-16910A, "Military Specification for Interference Measurement" available from the Commanding Officer, Naval Supply Depot, Scotia 2, New York.

(c) In the case of measurements in the field, radiation in excess of 15 uv/m at any frequency between 450 kc and 25 mc at the

border of the property and more than 15 feet from any power line crossing this border under the control and exclusive use of the person operating or authorizing the operation of the receiver will be considered an indication of non-compliance with the radiation requirements of this subpart.

#### §15.64 Certification of radio receivers.

(a) No radio receiver manufactured after the effective dates of this subpart that operates in the range 30 to 890 mc, including frequency modulation broadcast receivers and television broadcast receivers, shall be operated without a station license unless it has been certificated to demonstrate compliance with the radiation interference limits in this subpart.

(b) The owner or operator need not certificate his own receiver, if it has been certificated by the manufacturer or the distributor.

(c) Certification made by a manufacturer or the distributor shall be based on tests made on receivers actually produced for sale. Tests shall be performed on a sufficient number of production units to assure that all production units comply with the radiation limitations of this subpart.

(d) The certificate may be executed by an engineer skilled in making and interpreting field strength measurements.

(e) The certificate shall contain the following information:

- (1) Name of manufacturer or distributor of receiver,
- (2) Model number,
- (3) Brief description of receiver, including tuning range, type of circuit, purpose for which used (as broadcast, aircraft, etc.),
- (4) Brief statement of the measurement procedure used,
- (5) Date the measurements were made,
- (6) A summary of the data obtained,
- (7) A statement certifying that on the basis of measurements made, the radio receiver is capable of complying with the requirements of this part under normal operation with the usual maintenance.
- (8) The name and address of the certifying engineer, and name and address of his employer, if any, and
- (9) Date of the certificate.

(f) The certificate shall be retained by the owner, manufacturer or the distributor for a period of five years, and shall be made available upon reasonable request to an authorized Commission representative, or photostat furnished by mail. (See Section 15.65 for filing requirement with FCC.)

#### §15.65 Information to be filed with Commission.

(a) Each manufacturer, distributor or other certifying agency that issues certifications pursuant to this subpart shall file with the Commission a description of its measurement facilities used for certification.

(b) A copy of each certificate prepared by a manufacturer, distributor or certifying agency shall be filed with the Commission at the time the certificate is prepared.

§15.66 Identification of certificated receivers. Each certificated receiver shall be identified by a distinctive seal or label, which may be a part of the name plate and which shall state that the receiver has been certificated for compliance with the requirements of this subpart. The seal or label shall be permanently attached to the receiver and shall be readily visible for inspection by prospective purchasers.

§15.67 Operation of radio receivers aboard a ship. In addition to meeting the requirements of this part, a radio receiver operated aboard a ship shall also meet the requirements of Part 8 of this chapter.

#### §15.68 Effective date of this subpart.

(a) Except as provided in paragraphs (b), (c) and (d) of this section, all radio receivers that operate (tune) in the range 30 to 890 mc, including frequency modulation broadcast receivers and television broadcast receivers, manufactured after May 1, 1956 shall comply with the requirements of this subpart.

(b) The radiation interference limits above 260 mc and the certification requirement with respect thereto shall be met by all new models of UHF television broadcast receiver chassis placed in production after December 31, 1956 and by all UHF television broadcast receivers manufactured after June 30, 1957.

(c) The power line interference limit and the certification requirement with respect thereto shall be met by all new models of television broadcast receiver chassis placed in production after June 30, 1956, and by all television broadcast receivers manufactured after December 31, 1956.

(d) The radiation interference limits and the certification requirement with respect thereto shall be met by all pocket-type superregenerative receivers used in the one-way signalling service as defined in Part 6 of this chapter which are manufactured after December 31, 1956.

§15.69 Interference from a radio receiver. The operator of a radio receiver, regardless of tuning range, date of manufacture, or of certification, which causes harmful interference shall promptly take steps to eliminate the harmful interference.



# Abstracts and References

Compiled by the Radio Research Organization of the Department of Scientific and Industrial Research, London, England, and Published by Arrangement with that Department and the *Wireless Engineer*, London, England

NOTE: The Institute of Radio Engineers does not have available copies of the publications mentioned in these pages, nor does it have reprints of the articles abstracted. Correspondence regarding these articles and requests for their procurement should be addressed to the individual publications, not to the IRE.

Acoustics and Audio Frequencies.....	438
Antennas and Transmission Lines.....	438
Automatic Computers.....	439
Circuits and Circuit Elements.....	439
General Physics.....	441
Geophysical and Extraterrestrial Phenomena.....	442
Location and Aids to Navigation.....	443
Materials and Subsidiary Techniques.....	444
Mathematics.....	446
Measurements and Test Gear.....	447
Other Applications of Radio and Electronics.....	448
Propagation of Waves.....	448
Reception.....	448
Stations and Communication Systems.....	449
Subsidiary Apparatus.....	449
Television and Phototelegraphy.....	449
Transmission.....	450
Tubes and Thermionics.....	450

The number in heavy type at the upper left of each Abstract is its Universal Decimal Classification number and is not to be confused with the Decimal Classification used by the United States National Bureau of Standards. The number in heavy type at the top right is the serial number of the Abstract. DC numbers marked with a dagger (†) must be regarded as provisional.

## ACOUSTICS AND AUDIO FREQUENCIES

534:061.3(47) 305

Conference on Physical Acoustics and Ultrasonics, Moscow, 3rd-7th March 1955—(*Akust. Zh.*, vol. 1, pp. 182-190; April/June, 1955.) Abstracts are given of over 40 papers presented at the conference. See also *Uspekhi fiz nauk*, vol. 56, pp. 445-456 (Tartakovski).

534.1 306

Emission of Sound by the Vibrating Sides of an Arbitrary Wedge—G. D. Malyuzhinets. (*Akust. Zh.*, vol. 1, pp. 144-164 and 226-234; April/June and July/September, 1955.) An exact solution is obtained for the sound-pressure field inside the wedge, using Sommerfeld's integral. Analysis is presented first assuming the whole of each side to vibrate with the same velocity, and next taking account of nonuniform velocity distribution along the sides. The correction is shown between the given problem and that of diffraction by a rigid wedge. The effects of the edge on the radiated power are considered.

534.2-13:551.596.1 307

Propagation of Sound in Turbulent Atmosphere—G. Skeib. (*Z. Met.*, vol. 9, pp. 225-234; August, 1955.) Measurements were made over paths of lengths 50-150 m at frequencies from 100 cps to 4 kc. From the results, the order of magnitude of the damping due to the turbulence can be determined as a function of frequency and wind velocity, and conclusions can be drawn regarding the structure of the turbulence.

534.2-14 308

Investigation of the Sound Shadow in a Medium with a Vertical Gradient of Sound Velocity—A. N. Barkhatov. (*Akust. Zh.*, vol. 1,

The Index to the Abstracts and References published in the PROC. IRE. from February, 1954 through January, 1955 is published by the PROC. IRE. April, 1955, Part II. It is also published by *Wireless Engineer* and included in the March, 1955 issue of that journal. Included with the Index is a selected list of journals scanned for abstracting with publishers' addresses.

pp. 121-125; April/June, 1955.) An experimental investigation is reported of the propagation of sound in water with a vertical temperature gradient. Results are presented graphically.

534.2-14 309

Diffraction of Sound at a Thin Bounded Plate in a Liquid—L. M. Lyamshev. (*Akust. Zh.*, vol. 1, pp. 138-143; April/June, 1955.) A calculation is made of the scattering of sound by a thin plate fixed in an infinite rigid screen immersed in a liquid, taking account of the vibrations set up in the plate.

534.232-8:537.228.2 310

Electrostriction in Liquids and the Generation of Ultrasons by an Electrostrictive Method—H. Goetz. (*Z. Phys.*, vol. 141, pp. 277-293; July 20, 1955.)

534.61-8:534.522.1 311

Useful Ultrasonic Output of a Quartz Radiator in various Liquids [determined] by an Optical Method—S. Parthasarathy, M. Pancholy, and C. B. Tipnis. (*Z. Phys.*, vol. 142, pp. 14-20; August 27, 1955.)

534.7:621.39 312

The Relation between Quantitative Transmission Quality and Transmission Characteristic to the Japanese Language—T. Miura. (*Rep. elect. Commun. Lab. Japan*, vol. 3, pp. 14-24; July, 1955.) Articulation tests were made on women's speech transmitted by microphone to a measuring system. Consideration of the results indicates that a different method of calculating the score is required from that used for other languages.

534.7:621.395.813 313

Tonal Method of Determining the Intelligibility of Speech Transmitted by Communication Paths—A. D. Tkachenko. (*Akust. Zh.*, vol. 1, pp. 171-180; April/June, 1955.) The method described is based on the analysis of results of intelligibility tests in each of twenty frequency bands which together cover the af range from 117 cps to 10 kc. The theory is given and an example of the practical determination of intelligibility is described in some detail. The results obtained by this method were found to be in close agreement with those obtained by the more laborious "articulation-index" test method.

534.86:621.3.018.783 314

Nonlinear Distortion of Nonperiodic Signal in an Electroacoustic Path—A. V. Rimski-Korsakov. (*Akust. Zh.*, vol. 1, pp. 165-170; April/June, 1955.) The nonlinear response characteristic is approximated by an exponential polynomial. Expressions are then obtained for the spectral density of the second- and third-order distortion and for the second- to fifth-order dis-

ortion of input signals with rectangular or bell-shaped spectral characteristics respectively.

534.874.1:621.395.623.7 315

Directional Properties of Sound-Dispersive Lenses—L. N. Bondareva and M. I. Karnovskii. (*Akust. Zh.*, vol. 1, pp. 126-133; April/June, 1955.) The angular distribution of sound pressure is calculated for plano-ellipsoidal and plano-hyperboloidal acoustic lenses for several values of the refractive index, aperture angle, and distance from the virtual focus. The calculated curves are compared with experimental results. Such lenses are useful for improving the directional characteristics of loudspeakers.

621.395.623.743 316

The Electrostatic Loudspeaker—L. J. Bobb and E. C. Gulick. (*Audio*, vol. 39, pp. 22-24; September, 1955.) A semicylindrical es loudspeaker for the upper register of a high-fidelity commercial reproducer uses a light-weight polyester 0.0005 in. thick for the diaphragm.

621.395.623.8 317

Stereophonic Sound System covers Hollywood Bowl—O. Berliner. (*Audio*, vol. 39, pp. 14-16, 52; August, 1955.) Description of a large open-air sound-reinforcement system.

621.395.625.3:621.317.4 318

Absolute Measurements in Magnetic Recording—E. D. Daniel and P. E. Axon. (*B.B.C. Engng. Div. Monographs*, no. 2, pp. 1-9; September, 1955.) Measurement of the absolute magnitude of the surface induction of the tape is discussed in relation to the standardization of recorded level. Consideration is given to the possibility of measuring the absolute sensitivity of the various parts of the recording-reproducing chain, with a view to formulating an unequivocal representation of tape sensitivity.

## ANTENNAS AND TRANSMISSION LINES

621.315.212.011.21 319

The Choice of Impedance for Coaxial Radio-Frequency Cables—W. T. Blackband. (*Proc. Instn. elect. Engrs.*, Part B, vol. 102, pp. 804-814; November, 1955.) Cable design is considered in relation to attenuation per unit length, voltage rating and power ratings based on thermal and voltage limitations. A method is presented for determining the optimum proportioning to satisfy a specification of two or more cable properties. The criterion of a specified attenuation with minimum diameter is satisfactory for practical purposes. The best value of characteristic impedance is 75Ω for low-loss air-spaced cables and 50Ω for general-purpose thermoplastic cables. [See also 2299 of 1954 (Gutzmann).]

621.372 320

**The Launching of a Plane Surface Wave**—G. J. Rich. (*Proc. Instn. elect. Engrs.*, Part B, vol. 102, pp. 824-825; November, 1955.) Discussion on 1548 of 1955.

621.372.029.6 321

**Microwave High-Speed Continuous Phase Shifter**—W. Sichak and D. J. Levine. (*Proc. IRE*, vol. 43, Part 1, pp. 1661-1663; November, 1955.) A phase shifter is described comprising two helices, wound in the same sense, inside a circular waveguide, one of the helices being rotated at a desired rate. A model designed for operation at 9.4 mc is 5½ inches long and 1 inch in diameter, excluding the motor drive, and rotates at 3600 rpm.

621.372.2 322

**Reflection in Helical Lines at a Change in the Helix Pitch: Part I—Calculation Results and their Physical Significance**—G. Piefke. (*Arch. elekt. Übertragung*, vol. 9, pp. 369-374; August, 1955.) An investigation relevant to the design of traveling-wave tubes with band-pass characteristics. Analysis taking account of higher modes is simplified by assuming the pitch in one portion of the helix to have the limiting value 90 degrees. When the changes of pitch are not too great, the phase angles, which depend on all the modes, can be neglected, and only the fundamental wave considered.

621.372.8:621.318.134 323

**Magneto-optical Phenomena in a Rectangular Waveguide containing a Ferrite Plate**—A. L. Mikaelyan. (*Bull. Acad. Sci. U.R.S.S., sér. tech. Sci.*, no. 3, pp. 139-149; March, 1955. In Russian.) Results are presented graphically of calculations of the propagation characteristics of *H* waves, of frequency of the order of 10 kmc, in a waveguide partly filled with ferrite, in the presence of a transverse magnetic field. The effects of position and thickness of the ferrite plate, the dielectric constant, magnetization, frequency and waveguide dimensions are considered. Propagation in waveguides containing a ferrite/dielectric composite plate or a ferrite plate and isotropic layers is also considered. (See also 925 of 1955.)

621.372.8:621.318.134 324

**Theory of New Ferrite Modes in Rectangular Waveguide**—B. Lax and K. J. Button. (*J. appl. Phys.*, vol. 26, pp. 1184-1185; September, 1955.) Exact theory is presented for propagation in a waveguide containing one or two transversely magnetized ferrite slabs adjacent to the walls.

621.372.8:621.318.134 325

**New Ferrite Mode Configurations and their Applications**—B. Lax and K. J. Button. (*J. appl. Phys.*, vol. 26, pp. 1186-1187; September, 1955.) The mode configurations of the electric fields corresponding to the various solutions given in above abstract are illustrated.

621.396.67:621.396.932 326

**The Use of a Ring Array as a Skip-Range Antenna**—J. D. Tillman, W. T. Patton, C. E. Blakely, and F. V. Schultz. (*Proc. IRE*, vol. 43, Part 1, pp. 1655-1660; November, 1955.) The problem discussed is the development of a shore antenna for shore-to-ship communication at distances of 40 to 500 miles. An omnidirectional ring array of vertical  $\lambda/4$  antennas is used with alternative excitation so as to concentrate the energy (a) into the ground wave for daytime communication and for communication over distances less than about 200 miles at night, or (b) into the sky wave for night-time communication over greater distances. Range calculations are presented based on a 3-kw transmitter and an operating frequency of 3 mc.

621.396.67:621.866 327  
Special Winches for the New Aerial Instal-

lation of the Schwarzenburg Short-Wave Transmitter—H. R. Lerch. (*Tech. Mitt. schweiz. Telegr.—Teleph. Verw.*, vol. 33, pp. 312-316; August 1955. In German and French.) The antenna system discussed comprises seven masts of heights between 40 and 120m forming a three-arm star with two masts supporting flat-top antennas in each arm around a central mast. Instead of the customary stationary winch associated with each mast, two mobile winches were used; these are described and illustrated; they have given satisfactory service since autumn, 1953.

621.396.67.012.12 328

**Helicopter measures Antenna Patterns**—H. Brueckmann. (*Electronics*, vol. 28, pp. 134-136; November, 1955.) The measuring equipment described comprises a small signal source located at the center of a dipole antenna suspended from the helicopter by means of a nylon string; a constant-intensity signal is transmitted and the helicopter flies in circles round the antenna under test, ground equipment being provided to track the helicopter position. The radiation pattern of a complex antenna system can be plotted in under 3 h, accurate to within 20 per cent. Sources of error are discussed.

621.396.67.029.62:621.397.62 329

**Dual-Band Television Aerials**—F. R. W. Strafford. (*Wireless World*, vol. 61, pp. 539-542 and 607-610; November/December, 1955.) The inefficiency of band-I dipole antennas on band-III frequencies and the results of various modifications are shown by curves obtained experimentally.

621.396.67.73:621.396.93 330

**Design for Wide-Aperture Direction Finders**—R. C. Benoit, Jr., and M. W. Furlow. (*Tele-Tech & Electronic Ind.*, vol. 14, pp. 60-62, 108; September, 1955.) The antenna system of the U.S.A.F. direction finder AN/GRD-9 is described. It is developed from the German Willenweber uhf system and produces a pattern equivalent to that of a rotating planar array by means of a number of fixed elements arranged in a circle, with an inner circle of reflectors, the signals being picked up by a rotating commutator and appropriately delayed so that all arrive in phase at a common mixing point. For the experimental model described the frequency range covered is wider than 225-400 mc, the beam width being 6 degrees; bearings can be determined to within  $\pm 1$  degree.

621.396.67.71 331

**Radiation Characteristics of Axial Slots on a Conducting Cylinder**—J. R. Wait. (*Wireless Engr.*, vol. 32, pp. 316-323; December, 1955.) An extensive set of radiation patterns is presented for a narrow axial slot on a circular conducting cylinder of infinite length with a circumference up to 21 wavelengths. The results are also applicable to arrays of axial slots with an arbitrary distribution of transverse voltage. The effect of finite slot width is discussed and the external conductance of the slot is also considered.

621.396.67.7.833 332

**Determination of Aperture Phase Errors in Microwave Reflectors**—D. K. Cheng and P. Grusauskas. (*J. Franklin Inst.*, vol. 260, pp. 99-105; August, 1955.) "Using the vector notation of differential geometry, a general expression is obtained for the phase error in an aperture plane of any given reflector when the equation of the incident wavefront is known. For the special case of a point source, the formula can be readily applied to determine the aperture phase distribution for any source location."

## AUTOMATIC COMPUTERS

681.142 333  
An Attempt to simplify Coding for the Manchester Electronic Computer—R. A. Brooker.

(*Brit. J. appl. Phys.*, vol. 6, pp. 307-311; September, 1955.) Two main simplifications are made, both at the cost of increased machine time. To ensure that all quantities involved in a calculation are represented to the required degree of accuracy, every number occurring is associated with its own scale factor. Again, in using the two levels of storage provided, arrangements are made so that "instructions" are written out as if for a one-level store. A program in the simplified form is described.

681.142 334

**A Magslip Isograph**—G. M. Parker and R. W. Williams. (*J. Sci. Instrum.*, vol. 32, pp. 332-335; September, 1955.) The terms of a polynomial equation to be solved are represented by alternating voltages of varying time phases obtained from magslip transmitters. The instrument described is capable of solving sixth-degree equations having real coefficients, and may be used for the evaluation of polynomials.

681.142 335

**A Flutter Computer with Low Gain Amplifiers**—K. E. Wood and I. V. Mansford. (*Electronic Engr.*, vol. 27, pp. 477-481; November, 1955.) Low-gain dc amplifiers are used, thus avoiding drift troubles. The principle of the computer is to shift all the poles of the solution to the left in the complex *p* plane, *F(p)* being a stable solution of the problem. The method is useful in low-stiffness problems.

681.142:621.3.002.2 336

**Basic Chassis for Experimental Work**—N. M. Emslie. (*Electronics*, vol. 28, pp. 166-168; November, 1955.) Design details are given for a universal unit for use in computers, for manufacture in small quantities.

## CIRCUITS AND CIRCUIT ELEMENTS

621.3.012 337

**An Approximate Method for obtaining Transient Response from Frequency Response**—H. H. Rosenbrock. (*Proc. Instn. elect. Engrs.*, Part B, vol. 102, pp. 744-752; November, 1955.) A rapid method for finding the transient response of a linear system whose frequency response is known numerically, but not as an analytical function, involves use of a specially constructed transparent cursor. The technique can also be used to deal with the inverse problem or to derive an analytical function representing the behavior of a system of which either the frequency response or the transient response has been measured.

621.314.22:621.372.5 338

**Transformer Design on Insertion-Loss Principles**—H. Schilling. (*Telefunken Ztg.*, vol. 28, pp. 5-14; March, 1955. English summary, pp. 58-59.) Wideband-transformer data can be calculated using the normalized values for the circuit elements of high-pass and low-pass networks derived from insertion-loss theory for reactive quadripoles, examples of which are tabulated. By considering the transformer equivalent circuit as part of a Tchebycheff filter network of higher order, significant improvements can be made in the transmission characteristic. By introducing special low-permittivity layers between windings, further improvement is possible.

621.318.43:621.318.134 339

**Perpendicularly Superposed Magnetic Fields**—R. Hertz and H. O. Buelteman, Jr. (*Elect. Engrg., N. Y.*, vol. 74, p. 661; August, 1955.) Digest of a paper to be published in *Trans. Amer. Inst. elect. Engrs., Communications and Electronics*, 1955. Theory is outlined for a "cross-field reactor" comprising a hollow ferrite toroid carrying one annular winding internally and one toroidal winding externally. The device can be used as a low-level dc converter or modulator, as a variable inductance, or as a frequency multiplier or divider.

- 621.318.43:621.375.3 340  
**Analysis of Optimum [core] Shape for Magnetic Amplifiers**—B. D. Bedford, C. H. Willis, and G. C. Dodson. (*Elect. Engng., N. Y.*, vol. 74, p. 694; August, 1955.) Digest of paper to be published in *Trans. Amer. Inst. elect. Engrs., Communication and Electronics*, 1955.
- 621.318.57:621.374.32 341  
**Composite Multistable Circuit with Natural Quinary Cycle**—R. Favre. (*Helv. phys. Acta*, vol. 28, pp. 442-446; August 31, 1955. In French.) A circuit composed of binary and ternary stages is used, based on design principles described previously (3485 of 1954). Details are given of a decade unit embodying the circuit.
- 621.37/.39(083.74) 342  
**NBS-BuAer Preferred Circuits Program**—(*Tech. News Bull. nat. Bur. Stand.*, vol. 39, pp. 134-136; October, 1955.) Report of investigations made by the N.B.S., in conjunction with the U. S. Navy Bureau of Aeronautics, of the feasibility of standardizing the circuits used in electronic equipment.
- 621.372 343  
**Topological and Dynamical Invariant Theory of an Electrical Network**—T. C. Doyle. (*J. Math. Phys.*, vol. 34, pp. 81-94; July, 1955.)
- 621.372.029.6:621.3.018.75 344  
**Linear Transmission of Pulses at Centimetre Wavelengths**—E. Ledinegg. (*Arch. elekt. Übertragung*, vol. 9, pp. 363-368; August, 1955.) Analysis for the transmission of pulses of arbitrary shape by waveguide and cavity-resonator systems is based on use of Laplace transforms. Using theory presented previously [1700 of 1954 (Ledinegg and Urban)] a calculation is made of the transfer function for a system of weakly-coupled cavity resonators.
- 621.372.029.64:538.569.4 345  
**The Maser—New Type of Microwave Amplifier, Frequency Standard, and Spectrometer**—Gordon, Zeiger, and Townes. (See 403.)
- 621.372.412:549.514.51 346  
**Influence of the Order of Overtone on the Temperature Coefficient of Frequency of AT-Type Quartz Resonators**—R. Bechmann. (*Proc. IRE*, vol. 43, Part 1, pp. 1667-1668; November, 1955.)
- 621.372.413:538.221:621.318.134 347  
**Magnetic Fields in Small Ferrite Bodies with Applications to Microwave Cavities containing Such Bodies**—A. D. Berk and B. A. Lengyel. (*Proc. IRE*, vol. 43, Part 1, pp. 1587-1591; November, 1955.) An analysis is presented of the field inside small spheres and cylinders of ferrite excited by circularly or linearly polarized magnetic fields in cavities. The formulas derived are used to calculate the detuning and change of  $Q$  value of the cavity on introducing the ferrite body, or conversely to determine the ferrite permeability tensor from the observed changes in the cavity characteristics.
- 621.372.413.029.64:538.569.4 348  
**Increasing the  $Q$  Factor of the Cavity Resonator by Regeneration**—N. G. Basov, V. G. Veselago, and M. E. Zhabotinski. (*Zh. eksp. teor. Fiz.*, vol. 28, p. 242; February, 1955.) A brief note on the cavity resonator used in conjunction with the molecular-beam oscillator [100 of 1955 (Gordon et al.) and 2275 of 1955 (Basov and Prokhorov)]. A  $Q$  factor of  $5 \times 10^6$  has been obtained for periods of up to 20 minutes.
- 621.372.5 349  
**The Graphical Determination of the Geometrical Parameters of Loss-Free Linear Quadripoles**—J. de Buhr. (*Arch. elekt. Übertragung*, vol. 9, pp. 350-354; August, 1955.) The methods described previously (2864 and 3523 of 1955) are applied to determine the iterative impedance and iterative transfer constants.
- 621.372.5:538.652 350  
**Application of the Wiedemann Effect to the Magnetostrictive Coupling of Crossed Coils**—U. F. Gianola. (*J. appl. Phys.*, vol. 26, pp. 1152-1157; September, 1955.) An electromechanical quadripole is described comprising a tubular magnetostrictive ferrite core carrying crossed coils, one wound toroidally and the other as an external helix. Theory is presented in terms of an equivalent circuit. The device can be used for filtering, gating, phase-reversing, etc. Successful experiments with ferroxcube IV  $\epsilon$  cores operating at frequencies between 25 and 150 kc are reported.
- 621.372.54 351  
**Catalogue of Power-Law and Tchebycheff-Type Filters up to Order  $n=5$** —E. Glowatzki. (*Telefunken Ztg.*, vol. 28, pp. 15-22; March, 1955. English summary, p. 59.) Four tables give the circuit diagrams and the normalized values of the circuit elements in maximally-flat-response and Tchebycheff-type filters (a) terminated, and (b) with a short or open circuit at one end, for different values of the pass-band reflection coefficient. Corresponding attenuation characteristics are given in 15 diagrams. The application of the tables is illustrated in five numerical examples. (See also 1903 of 1955.)
- 621.372.54.029.3:621.372.57 352  
**Electrically-Controlled Audio Filters**—L. O. Dolanský. (*Proc. IRE*, vol. 43, Part 1, pp. 1580-1586; November, 1955. 1955 IRE CONVENTION RECORD, vol. 3, Part 7, pp. 41-48.) Design theory based on the work of Linvill (1711 of 1954) is presented for a low-pass and a high-pass filter both having cut-off frequencies continuously variable between 200 cps and 1 kc. The cut-off characteristic may be controlled by the af signal for investigating the structure of speech signals. Experimental results are reported.
- 621.372.543.2.029.62/.63 353  
**U.H.F. Multiplex uses Selective Couplers**—H. J. Carlin. (*Electronics*, vol. 28, pp. 152-155; November, 1955.) An arrangement is described comprising directional couplers incorporating filter properties combined to form a system enabling several transmitters and receivers to be operated with a single antenna in the frequency range 225-400 mc. A coaxial-line construction with tuned cavity resonator is used. A four-coupler system with separation of 3 mc between channels can provide adjacent-channel reduction of 60 db with insertion loss of 1 db.
- 621.372.55 354  
**Equivalent Equalizer Networks**—R. O. Rowlands. (*Wireless Engr.*, vol. 32, pp. 323-327; December, 1955.) The various types of frequency-response curves obtainable with practical networks of the derivative-equalizer type [1936 of 1953 (Gouriet)] are analyzed and the equivalent constant-resistance networks are determined.
- 621.373.4:621.316.726 355  
**Improvement of Stabilized Pound Oscillator**—J. Hervé. (*C.R. Acad. Sci., Paris*, vol. 241, pp. 746-749; September 19, 1955.) Adjustment of the oscillator is facilitated by means of a sawtooth generator with switching arrangements such that it can be interpolated at various points in the circuit, the attainment of the desired oscillator characteristic being indicated on a cro.
- 621.373.431.2:621.373.52:621.314.7 356  
**Junction-Transistor Blocking Oscillators**—J. G. Linvill and R. H. Mattson. (*Proc. IRE*, vol. 43, Part 1, pp. 1632-1639; November, 1955.) Circuits have been designed producing pulses with rise times  $< 0.1 \mu s$ , using transistors with  $\alpha$ -cut-off frequencies of a few mc. Details of the regenerative transformer coupling are discussed. Triggering requirements and the effects of loading are evaluated. Experimental results support the theory.
- 621.373.444 357  
**Stabilization of Pulse Duration in Monostable Multivibrators**—A. C. Luther, Jr. (*RCA Rev.*, vol. 16, pp. 403-422; September, 1955.) Pulse-duration stabilization of triggered circuits by dc feedback is described. Practical circuits suitable for frequency division and pulse generation in television equipment are illustrated.
- 621.373.52:621.314.7 358  
**Transistor Pulse Generators**—W. S. Eckess, J. E. Deavenport, and K. I. Sherman. (*Electronics*, vol. 28, pp. 132-133; November, 1955.) Numerical design data are given for four circuits using Ge junction transistors and one using a Si transistor. Pulse rise times as low as  $0.1 \mu s$  are attainable at repetition frequencies up to 50,000 pulses/second; pulse durations are variable from 0.4 to  $9 \mu s$ .
- 621.374.4:621.318.435:621.396.96 359  
**Saturable-Reactor Frequency Divider**—G. W. G. Court and C. I. C. Scollay. (*Wireless Engr.*, vol. 32, pp. 328-329; December, 1955.) A saturable reactor is used in conjunction with a RC network to provide a circuit capable of producing a pulse output at the frequency, or a submultiple of the frequency, of a sinusoidal input. A circuit providing synchronizing pulses for a radar modulator at half the frequency of the 400-cps power supply is described.
- 621.375.2.024 360  
**Automatic Drift Compensation in D.C. Amplifiers**—I. Cederbaum and P. Balaban. (*Rev. sci. Instrum.*, vol. 26, pp. 745-747; August, 1955.) The circuit discussed is similar to that described by Offner (3511 of 1954). It may be used in systems where periodic interruption of the input and noncontinuous compensation are permissible, as in analog computers, sampling amplifiers, etc.
- 621.375.221.2 361  
**Optimum Tube Utilization in Cascaded Distributed Amplifiers**—A. I. Talkin and J. V. Cuneo. (*Proc. IRE*, vol. 43, Part 1, pp. 1668-1669; November, 1955.) Analysis is presented taking account of the bandwidth-narrowing factor introduced by cascading stages; this factor is evaluated for an amplifier using constant- $R$  bridged-T lines. A numerical example is discussed.
- 621.375.227 362  
**Rejection Factor of Difference Amplifiers**—G. Klein. (*Philips Res. Rep.*, vol. 10, pp. 241-259; August, 1955.) Analysis shows that the rejection factor of a differential amplifier can be made arbitrarily large without necessitating preselection of tubes or exact equality of the two halves of the circuit. The theory is supported by experimental results. The parameter termed "rejection factor" is the same as that termed "transmission factor" by Parnum (1636 of 1950).
- 621.375.3 363  
**Magnetic Amplifiers as Control Components**—W. La Pierre. (*Product Engng.*, vol. 26, pp. 129-133; August, 1955.) The advantages and limitations of magnetic amplifiers for voltage and current control, switching and amplifying are compared with those of various other devices; important properties are tabulated.
- 621.375.3:621.383.5:621.314.63 364  
**A Germanium Diffused-Junction Photoelectric Cell**—Waddell, Mayer and Kaye. (See 615.)
- 621.375.327.024 365  
**Low Level Magnetic Amplifier**—F. Gour-

ash. (*Tele-Tech & Electronic Ind.*, vol. 14, pp. 90-91, 160; August, 1955.) A two-stage push-pull dc amplifier is described in which a high degree of negative feedback is used to obtain stability and linearity, with high input impedance. By careful balancing of components the zero drift, measured in terms of input power, is reduced to the order of  $10^{-12}$  w.

621.375.4:621.314.7 366  
**Transistor Power Amplifiers**—R. A. Hilbourne and D. D. Jones. (*Proc. Instn. elect. Engrs.*, Part B, vol. 102, pp. 763-774; November, 1955. Discussion, pp. 786-792.) Discussion of conditions for *p-n-p* junction transistors handling sinusoidal signals indicates that the maximum possible output is not necessarily limited by the maximum allowable collector dissipation; limitations set by the variation of current gain with emitter current become particularly significant in class-B amplifiers because of their very high efficiencies. Push-pull class-B operation is preferred to class A; of the three possible basic connections the common-collector arrangement is preferred as providing the best compromise between gain and distortion and permitting the simplest design of output transformer. No great advantage is found by using complementary *n-p-n* and *p-n-p* transistors. Applications involving nonsinusoidal signals are discussed briefly.

621.375.4:621.314.7 367  
**Predictable Design of Transistor Amplifiers**—R. B. Hurley. (*Tele-Tech & Electronic Ind.*, vol. 14, pp. 74-75, 168; August, 1955.) The transfer characteristic of a multistage low-frequency amplifier using junction transistors may be made independent of the transistor characteristics by the use of degenerative current feedback, at the same time improving linearity. The importance of stable biasing arrangements is emphasized.

621.375.4:621.314.7 368  
**Simplified Design Procedures for Tuned Transistor Amplifiers**—C. C. Cheng. (*RCA Rev.*, vol. 16, pp. 339-359; September, 1955.)

621.375.4:621.314.7 369  
**Maximum Power Transfer in Transistor Amplifiers**—G. L. Fougere. (*Electronic Engng.*, vol. 27, pp. 492-493; November, 1955.) The theoretical treatment of transistor-amplifier performance is simplified by restricting consideration to the condition of maximum power transfer, when it is possible to make a rapid assessment of the available power gain for a particular configuration, in terms of the transistor parameters. Curves show the relation between maximum power gain, current gain, and transistor constants for grounded-base and ground-collector arrangements.

621.375.9:621.385.032.216 370  
**Properties of Pore Conductors**—Forman. (See 630.)

#### GENERAL PHYSICS

530.112 371  
**Some Considerations regarding the Principle of Phase Invariance**—F. A. Kaempffer. (*Canad. J. Phys.*, vol. 33, pp. 436-440; August, 1955.) It is shown that the conservation laws characterizing the ether can be derived from the principle of phase invariance provided a complex field is used to describe the ether.

530.145:539.153:548.0 372  
**Tamm Equations of State of Electrons at the Surface of a Crystal and Surface Oscillations of Lattice Atoms**—I. M. Lifshits and S. I. Pekar. (*Uspekhi fiz. Nauk.*, vol. 56, pp. 531-568; August, 1955. A review. About half of the 68 references are to Russian work.

535.215 373  
**Photo [-electric] Effect in Metals**—S. V. Vonsovski, A. V. Sokolov, and A. Z. Veksler.

(*Uspekhi fiz. Nauk.*, vol. 56, pp. 477-530; August, 1955.) A critical survey with particular reference to the theoretical development of the subject. 65 references.

535.376 374  
**Electroluminescence excited by Short Field Pulses**—F. Matossi and S. Nudelman. (*Phys. Rev.*, vol. 99, pp. 1100-1103; August 15, 1955.) An extension of a previous investigation [1307 of 1955 (Nudelman and Matossi)] is reported; pulses of duration 40-2,500  $\mu$ s were used. The luminescence decay rate is highest for the shortest pulses. Results are consistent with previous conclusions regarding polarization effects [2898 of 1955 (Matossi)]; a threshold pulse duration of about 700  $\mu$ s is estimated to be necessary for the accumulation of polarization charges.

535.376 375  
**Dependence of Light Amplification in Phosphors on Light Intensity**—F. Matossi. (*Phys. Rev.*, vol. 99, pp. 1332-1333; August 15, 1955.)

535.623:621.397.5 376  
**Differential Chromaticity Thresholds in the Direction of Primary Blue in a Trichromatic-Synthesis System**—Billard. (See 583.)

537.226 377  
**Dielectric Properties of Ice at Very Low Frequencies and the Influence of a Polarizing Field**—H. Gränicher, C. Jaccard, P. Scherrer, and A. Steinemann. (*Helv. phys. Acta.*, vol. 28, pp. 300-303; August 31, 1955. In German.) Measurements at frequencies down to 0.7 cps are reported. The loss factor passes through a low-frequency maximum which is distinguishable from that associated with the dipole dispersion by its different temperature dependence. The effect of impurities is to shift the maximum towards higher frequencies. Application of a unidirectional field does not affect the permittivity of the pure crystals but eliminates the low-frequency dispersion when impurities are present. The observations are consistent with MacDonald's theory (1024 of 1954).

537.226.2 378  
**The Dielectric Constant of an Imperfect Non-Polar Gas**—A. D. Buckingham and J. A. Pople. (*Trans. Faraday Soc.*, vol. 51, pp. 1029-1035; August, 1955.)

537.311.31 379  
**Electron-Phonon Interaction in Metals**—J. Bardeen and D. Pines. (*Phys. Rev.*, vol. 99, pp. 1140-1150; August 15, 1955.) "The role of electron-electron interactions in determining the electron-phonon interaction in metals is investigated by extending the Bohm-Pines collective description to take into account the ionic motion."

537.311.31:537.312.8 380  
**Single Band Motion of Conduction Electrons in a Uniform Magnetic Field**—P. G. Harper. (*Proc. Phys. Soc.*, vol. 68, pp. 874-878; October 1, 1955.)

537.311.31:537.312.8:538.113 381  
**The General Motion of Conduction Electrons in a Uniform Magnetic Field, with Application to the Diamagnetism of Metals**—P. G. Harper. (*Proc. Phys. Soc.*, vol. 68, pp. 879-892; October 1, 1955.)

537.311.37:537.562 382  
**Theory of the Electrical Conductivity of a Plasma**—H. Schirmer. (*Z. Phys.*, vol. 142, pp. 1-13; August 27, 1955.) The calculation presented is based on integration of the Boltzmann equation in which the atoms, ions, and electrons are not treated as rigid, perfectly elastic spherical scattering centers.

537.312.8 383  
**The Importance and the Origin of Modes of Description of Magnetogalvanic Effects**—A. L.

Perrier. (*Helv. phys. Acta.*, vol. 28, pp. 312-316; August 31, 1955.) [See also 2337 of 1955 (Perrier and Ascher).]

537.5 384  
**Statistical Description of Assemblies with Collective Interaction: Part 3—The Various Formulations of the Carrier Kinetics**—G. Eckert. (*Z. Phys.*, vol. 141, pp. 294-306; July 20, 1955.) The range of validity of approximations made in analyses by other workers is discussed. Parts 1 and 2: 2907 of 1955.

537.5 385  
**Pulse-Controlled Cathode Sputtering and Electron Emission**—A. Güntherschulze. (*Z. Phys.*, vol. 141, pp. 346-353; July 20, 1955.)

537.5 386  
**Electron Liberation by Low-Energy Ions at Metal Surfaces and in Gases**—H. Fetz. (*Brit. J. appl. Phys.*, vol. 6, pp. 288-291; August, 1955.) Two experimental methods of investigation are described; the disturbing influence of photo-ionization was completely eliminated. Results indicate that in certain cases ionization in the gas by collision of ions may be important.

537.52 387  
**Mechanism of Uniform Field Breakdown in Hydrogen**—A. Wilkes, W. Hopwood, and N. J. Peacock. (*Nature, Lond.*, vol. 176, pp. 837-838; October 29, 1955.)

537.523 388  
**Growth of Current between Parallel Plates**—P. M. Davidson. (*Phys. Rev.*, vol. 99, pp. 1072-1074; August 15, 1955.) Analysis for the initial stages of a discharge involving secondary electron emission is presented in an alternative form to that given previously [3262 of 1953 (Dutton et al.; mathematical appendix by Davidson)].

537.525.8:535.215 389  
**Reduction of the Cathode Fall [of potential] of a Normal Glow Discharge by Illumination of the Cathode**—W. Kluge and A. Schulz. (*Z. Phys.*, vol. 142, pp. 83-86; August 27, 1955.) Experimental results indicate that the relation between the normal cathode fall  $f^{*11} U_{kn}$  the cathode work function  $\Phi_0$  and the current density due to illumination  $j_0$  is given by  $U_{kn} = A\Phi_0 - Bj_0$ , where  $A$  is a constant whose magnitude depends on the ionization potential of the gas and  $B$  is another constant. A special Ag-base cathode with  $KH$  and adsorbed  $K$  layers was used (585 of 1955).

537.525.8:537.212.082.72 390  
**Measurement of Electric Fields as applied to Glow Discharges**—R. W. Warren. (*Rev. sci. Instrum.*, vol. 26, pp. 765-770; August, 1955.) A magnetically compensated zero-deflection electron-beam method is described. Using automatic recording, field strengths between 1,000 v/cm and 0.2 v/cm can be rapidly measured and tube-wall potentials can simultaneously be recorded.

537.533 391  
**Electron Emission from Cathode Surfaces after Glow Discharges**—R. Röhler. (*Naturwissenschaften*, vol. 42, pp. 459-460; August, 1955.) Brief account of experiments made to elucidate exo-electron-emission phenomena.

537.533 392  
**T-F [temperature and field] Emission: Experimental Measurement of the Average Electron Current Density from Tungsten**—W. P. Dyke, J. P. Barbour, E. E. Martin, and J. K. Trolan. (*Phys. Rev.*, vol. 99, pp. 1192-1195; August 15, 1955.) The results of the experiments reported support the theory presented previously [88 of 1955 (Dolan and Dyke).]

537.533:530.145 393  
**Quantum Effects in the Interaction between Free Electrons and Electromagnetic Fields**—

- P. S. Farago and G. Marx. (*Phys. Rev.*, vol. 99, pp. 1063-1064; August 15, 1955.) A discussion of the possibility of arranging experiments so that the spread of an electron beam in a transverse rf field due to the quantum dispersion of the energy exchange can be distinguished from that due to practical experimental factors.
- 537.533:535.31 394  
**Two Problems in Geometrical Optics and Application of the Results in Electron Trajectory Calculations**—S. V. Yadavalli. (*Proc. IRE*, vol. 43, Part 1, pp. 1670-1671; November, 1955.)
- 537.56 395  
**A Semi-empirical Expression for the First Townsend Coefficient of Molecular Gases**—R. W. Crowe, J. K. Bragg, and J. C. Devins. (*J. appl. Phys.*, vol. 26, pp. 1121-1124; September, 1955.) The formula derived by Druyvesteyn and Penning (*Rev. mod. Phys.*, vol. 12, pp. 87-174; April, 1940) is discussed and is modified on the basis of different assumptions regarding the energy dependence of the scattering cross-sections of the gas molecules.
- 537.56 396  
**Atomic Negative-Ion-Photodetachment Cross-Section and Affinity Measurements**—S. J. Smith and L. M. Branscomb. (*J. Res. nat. Bur. Stand.*, vol. 55, pp. 165-176; September, 1955.) "The spectral distributions of the  $H^-$  and  $O^-$  cross sections for photodetachment have been measured. The  $H^-$  measurements are consistent with the theory of Chandrasekhar. A curve has been fitted to the results for  $O^-$ . The threshold of this cross section, the affinity of  $O^-$ , is found to be  $1.48 \pm 0.10$  electron volts. No evidence is found for resonance at the threshold or for the existence of excited  $O^-$  ions. The apparatus is described in detail."
- 538.114 397  
**Dipolar Ferromagnetism at  $0^\circ K$** —M. H. Cohen and F. Keffer. (*Phys. Rev.*, vol. 99, pp. 1135-1140; August 15, 1955.)
- 538.566:517 398  
**Asymptotic Expansions of Solutions of  $(\nabla^2 + k^2)u = 0$** —F. G. Friedlander and J. B. Keller. (*Commun. pure appl. Math.*, vol. 8, pp. 387-394; August, 1955.) The equation investigated is important in the theory of wave propagation. A direct method is developed for obtaining more general asymptotic expansions than those given previously [646 of 1952 (Kline).]
- 538.566:535.42 399  
**Strict Theory of the Diffraction of Electromagnetic Waves by Plane Screens**—K. Westpfahl. (*Z. Phys.*, vol. 141, pp. 354-373; July 20, 1955.) Analysis is based on the Hertz, or Fitzgerald, vector, which can be represented by a double Fourier integral; the Fourier amplitudes giving the angular distribution of the far field are derived from a system of simultaneous integral equations which can be solved approximately by developing in certain orthogonal systems. An alternative method of solution is an iteration process based on the Kirchhoff approximation. The relation with Huyghens' principle and with the variation problem of diffraction theory is established.
- 538.566:535.42 400  
**Diffraction of Microwaves by Long Metal Cylinders**—A. W. Aday. (*Canad. J. Phys.*, vol. 33, pp. 407-419; August, 1955.) Report of an experimental investigation at about  $3 \text{ cm } \lambda$ , using parallel-plate equipment based on that described by El-Kharadly (*e.g.*, 1261 of 1955) and cylindrical obstacles of transverse dimensions comparable with  $\lambda$ . Calculated and experimental results for circular cylinders are in good agreement and are used as a basis for studying diffraction by square and rectangular cylinders.
- The method gives reliable information about scattering from obstacles of forms such that no exact theoretical solutions are available.
- 538.566:535.43 401  
**On the Scattering Cross Section of an Obstacle**—D. S. Jones. (*Phil. Mag.*, vol. 46, pp. 957-962; September, 1955.) The relation between the scattering cross-section and the scattered amplitude for an obstacle in an incident plane wave, previously discussed by van de Hulst (601 of 1950), is here established by a calculation of the energy flow. When the incident wave emanates from a point source, the sum of the scattering and absorption cross sections is determined by the value of a certain field in the neighborhood of the source. The discussion is presented in terms of an em wave, but is adaptable to sound waves or atomic collisions.
- 538.569.4:621.372.029.64 402  
**Possible Methods of obtaining Active Molecules for the Molecular Generator**—N. G. Basov and A. M. Prokhorov. (*Zh. ekspl. teor. Fiz.*, vol. 28, pp. 249-250; February, 1955.) The use is suggested of an auxiliary hf field to produce resonance transitions between the energy levels in the molecules such as to increase the fraction of active molecules in the beam. (See also 348 above and back references.)
- 538.569.4:621.372.029.64 403  
**The Maser—New Type of Microwave Amplifier, Frequency Standard, and Spectrometer**—J. P. Gordon, H. J. Zeiger, and C. H. Townes. (*Phys. Rev.*, vol. 99, pp. 1264-1274; August 15, 1955.) Experimental results with the device described previously (100 of 1955) are compared with predictions from theory. Particular attention is given to operation with ammonia molecules. An amplifier noise figure of unity should be attainable under certain conditions.
- 539.15.098:538.569.4 404  
**Influence of an Inhomogeneity of the High-Frequency Field in Nuclear Magnetic Resonance**—H. Pfeifer. (*Z. angew. Phys.*, vol. 7, pp. 389-391; August, 1955.) Theoretical results show that, to a first-order approximation, the inhomogeneity has no effect on the signal amplitude provided that the conditions for a maximal signal in a homogeneous field are fulfilled.
- GEOPHYSICAL AND EXTRATERRESTRIAL PHENOMENA**
- 523.16 405  
**Radio Stars and their Cosmological Significance**—M. Ryle. (*Observatory*, vol. 75, pp. 137-147; August, 1955.) A survey presented as the 1955 Halley lecture. [See also 3588 of 1955 (Ryle and Scheuer).]
- 523.16:523.4 406  
**Location on Jupiter of a Source of Radio Noise**—C. A. Shain. (*Nature, Lond.*, vol. 176, pp. 836-837; October 29, 1955.) Earlier records of rf radiation and of visually observed activity on Jupiter are discussed in relation to the observation of a rf source by Burke and Franklin (2933 of 1955); this rf source is probably identifiable with the visibly disturbed region observed by Fox (*J. Brit. astr. Assoc.*, vol. 62, p. 280; 1952).
- 523.16:523.45 407  
**On the Great Importance of the R.F. Radiation from the Planet Jupiter**—Q. Majorana. (*R.C. Accad. naz. Lincei*, vol. 19, pp. 17-22; July/August, 1955.) Continuation of the previous discussion (3591 of 1955) of the observations reported by Burke and Franklin (2933 of 1955). The cyclic variation of relative position of points on Jupiter and on the earth is examined. Based on considerations of temperature and composition, the hypothesis is advanced that the observed radiation is produced by continuous eruption of solid electrified blocks of iron with linear dimensions of the order of  $\lambda/4$ ; such eruptions could be expected in the vicinity of the large red spot on Jupiter. The relevance of the hypothesis to astronomical problems is briefly indicated.
- 523.16:546.11.02 408  
**Monochromatic Radiation of Deuterium at a Wavelength of 91.6 cm from the Centre of the Galaxy**—G. G. Getmantsev, K. S. Stankevich, and V. S. Troitski. (*C. R. Acad. Sci. U.R.S.S.*, vol. 103, pp. 783-786; August 11, 1955. In Russian.) A brief report is presented of observations indicating the presence of deuterium in the interstellar space; the concentration is about  $3 \times 10^{-2}$  that of the non-ionized hydrogen. A block diagram is given of the equipment used in conjunction with a  $\lambda/2$  dipole antenna at the focus of a 4 m-diameter parabolic reflector.
- 523.5 409  
**Note on the Electrophysical Determination of the Velocities of Meteors**—C. Hoffmeister. (*Naturwissenschaften*, vol. 42, p. 458; August, 1955.) The question is briefly discussed whether the trail is electrically reflecting immediately after passage of the meteor or only after the ionized cylinder has expanded to a certain diameter. The answer is decisive for the theory of the origin of the interplanetary material.
- 523.53:621.396.96 410  
**The Giacobinid Meteor Stream**—J. G. Davies and A. C. B. Lovell. (*Mon. Not. R. astr. Soc.*, vol. 115, pp. 23-31; 1955.) An account is given of the systematic radio-echo observations in the years 1947-1954; the unexpected return of the meteor shower during the daytime in 1952 and the significance of its absence in 1953 are discussed.
- 523.7:621.396.822.029.6 411  
**Influence of the Age of [solar] R.F. Centres on their Radiation at Centimetre Wavelengths**—B. Vanquois. (*C.R. Acad. Sci., Paris*, vol. 241, pp. 739-740; September 19, 1955.) Continuation of investigation reported previously (2939 of 1955). The rf flux from an active center appears to vary directly as its sunspot area for the first 15 days of its life, after which it decreases more slowly than the sunspot area. The corresponding "aging function" is shown graphically.
- 523.72:551.510.535 412  
**Brightening of the Solar Limb in the Far Ultra-Violet**—C. M. Minnis. (*Nature, Lond.*, vol. 176, pp. 652-653; October 1, 1955.) Locations and relative intensities of sources controlling the  $E$  and  $F_1$  layers, as provisionally determined from measurements of electron density made at Slough and Inverness during the solar eclipse of June 30, 1954, indicate brightening of the solar limb near the equator and darkening of the limb at the poles. The intensity distribution over the solar disk is similar to that found by Christiansen and Warburton (2606 of 1955) for radiation on 21 cm $\lambda$ .
- 550.3 413  
**Electromagnetic Induction in a Two-Layer Earth**—B. K. Bhattacharyya. (*J. geophys. Res.*, vol. 60, pp. 279-288; September, 1955.) The theory developed by Price (1617 of 1951) is extended to determine the induced field on the surface of a medium whose conductivity is a function of depth. The results are applied to evaluate the field induced when an oscillating magnetic dipole is placed on the surface of a flat two-layer earth.
- 550.380.8 414  
**A Measurement of the Earth's Magnetic Field by Nuclear Induction**—G. S. Waters. (*Nature, Lond.*, vol. 176, p. 691; October 8, 1955.) The free-precession technique outlined by Packard and Varian (*Phys. Rev.*, vol. 93, p. 491; February 15, 1954) is used.

- 550.385 415  
Daytime Enhancement of Size of Sudden Commencements [SC's] and Initial Phase of Magnetic Storms at Huancayo—S. E. Forbush and E. H. Vestine. (*J. geophys. Res.*, vol. 60, pp. 299-316; September, 1955.) Statistical analysis of data for the period 1922-1946 shows that the frequency of occurrence of SC's is independent of the time of day, but that the average size of SC's and of initial phases of magnetic storms is greater during daylight hours. The size is also found to vary directly with the amplitude of the diurnal variation of  $H$ . Both phenomena may be due to electrojets in polar latitudes caused by the sun.
- 550.385:523.78 416  
Magnetic Effects during Solar Eclipses—A. M. van Wijk. (*J. geophys. Res.*, vol. 60, pp. 297-298; September, 1955.) Records taken in South Africa at the time of the annular eclipse of the sun on December 25, 1954 show a decrease in horizontal intensity of the geomagnetic-field horizontal component, in accordance with theory, but also an increase in the vertical component.
- 551.510.5 417  
Observation of an "Ozone Hole" over the Alps—H. K. Paetzold and H. Zschörner. (*Z. Met.*, vol. 9, pp. 250-251; August, 1955.) Observations are reported which throw light on the relations between vertical air streams in the stratosphere and the vertical distribution of ozone.
- 551.510.535 418  
Movements of Irregularities in the  $E$  Region—T. Obayashi. (*J. Radio Res. Labs, Japan*, vol. 2, pp. 59-67; January, 1955. *Rep. Ionosphere Res. Japan*, vol. 9, pp. 105-113; June, 1955.) Summer-night observations of fading patterns of transmissions from three broadcasting stations spaced about 150 km apart at the vertices of a triangle are consistent with large-scale movements in the  $E$  region, from east to west, with velocities of 50-150 m. Rapid fading, with a duration of a few hours, is considered to be due to scattering by  $E_s$  clouds showing turbulent velocities of 10-15 m.
- 551.510.535 419  
World-Wide Daily Variations in the Height of the Maximum Electron Density of the Ionospheric  $F_2$  Layer—T. Shimazaki. (*J. Radio Res. Labs, Japan*, vol. 2, pp. 85-97; January, 1955.) A formula relating  $h_p F_2$  to  $(M 3,000) F_2$  is applied to determine world-wide latitudinal variations of  $h_p F_2$  for 1952, the results so obtained being in good agreement with results published by local observatories. In middle and higher latitudes  $h_p F_2$  rises in summer daytime and falls in winter daytime. Near the equator there is a daytime rise throughout the year.
- 551.510.535 420  
A Discussion on the Variation of  $F$ -Region Height—B. Chatterjee. (*J. geophys. Res.*, vol. 60, pp. 325-327; September, 1955.) Further evidence is adduced in support of the author's suggestions regarding the distribution of ionization in the  $F$  region (2939 of 1954).
- 551.510.535 421  
Contribution to the Study of the Effect of Geomagnetism on the  $F_1$  Layer—R. Eyfrig. (*C.R. Acad. Sci., Paris*, vol. 241, pp. 759-761; September 19, 1955.) Results of an analysis of observations for 1943, 1944, and 1954 confirm the dip in the value of  $f_0 F_1$  at the magnetic equator reported by Ghosh (1983 of 1955). There is also a minimum in the values of the  $(M 3,000) F_1$  factor and the  $muf$  at the magnetic equator.
- 551.510.535:523.16 422  
Radio Star Scintillations and the Ionosphere—T. R. Hartz. (*Canad. J. Phys.*, vol. 33, pp. 476-482; August, 1955.) "The observed intensity at the surface of the earth of radiation at a frequency of 50 mc from a radio star has been studied. A relationship is shown to exist between the fluctuations, or scintillations, in this observed radiation intensity and the angle of its incidence on the 400 km level of the earth's ionosphere. The occurrence of these scintillations is compared with other ionospheric phenomena as determined by vertical soundings from the earth. The probable cause of the fluctuations has been localized to a source in the high ionospheric regions."
- 551.510.535+550.385]:523.75 423  
Effect of Radiation from Solar Flares on the Ionosphere and the Earth's Magnetic Field—R. N. Sedra and I. B. Hazzaa. (*Phys. Rev.*, vol. 99, pp. 1070-1072; August 15, 1955.) "Variation in the earth's magnetic field and the corresponding variations in the ionic density of the  $F_1$  layer due to solar flares are recorded. The value of the intensity of ultraviolet radiation before it enters the atmosphere is obtained. The constant relating the ionic density and the accompanying magnetic variation is also estimated."
- 551.510.535:550.38 424  
Geomagnetic Distortion of the  $F_2$  Region on the Magnetic Equator—M. Hirono and H. Maeda. (*J. geophys. Res.*, vol. 60, pp. 241-255; September, 1955.) (See 3257 of 1955.)
- 551.510.535:550.38 425  
Researches on the Geomagnetic Distortion in the Ionosphere—(*Rep. Ionosphere Res. Japan*, vol. 9, pp. 59-104; June, 1955.)  
Part 1—Observed Facts of the Geomagnetic Distortion in the Ionosphere—H. Maeda (pp. 59-70).  
Part 2—Theoretical Study on the Geomagnetic Distortion in the  $F_2$  Layer—K. Maeda (pp. 71-85).  
Part 3—Characteristics of the  $F_2$  Layer on the Magnetic Equator—M. Hirono and H. Maeda (pp. 86-94).  
Part 4—Effect of Gravity and Ionization Pressure Gradient on the Vertical Drift in the  $F_2$  Region—M. Hirono (pp. 95-104).  
World-wide observations made during the sun-spot minimum period (1953-1954) and during the second Polar Year (1932-1933) are analyzed and discussed theoretically. The anomalous distribution in the  $F_2$  region above the magnetic equator may be explained by vertical electron drifts caused by the electric field. An ionospheric model consistent with the results of rocket experiments is used. The particle density at altitude 300 km must be of the order of  $10^{10}/\text{cm}^3$ .
- 551.510.535:550.385 426  
Studies on the Disturbances in  $F_2$  Layer associated with Geomagnetic Disturbances—K. Sinno. (*J. Radio Res. Labs, Japan*, vol. 2, pp. 69-76; January, 1955.) Earlier work is summarized and discussed. (See also 3258 of 1955.)
- 551.593.5 427  
Day Sky Brightness to 220 km—O. E. Berg. (*J. geophys. Res.*, vol. 60, pp. 271-277; September, 1955.) Measurements made with rocket-borne stereocameras suggest that the brightness is due entirely to Rayleigh scattering by air molecules. There is no evidence of high-altitude clouds.
- 551.594.5:621.396.11 428  
Double-Doppler Radar Investigations of Aurora—A. G. McNamara. (*J. geophys. Res.*, vol. 60, pp. 257-269; September, 1955.) The power spectra of auroral echoes of signals on 90.7 mc are compared with observations of the visible auroras and with simultaneous echoes of signals on 56 and 106 mc, using standard high-resolution radar equipment. A number of auroral models are considered in a discussion of the results.
- 551.594.5:621.396.11 429  
Auroral Echoes observed North of the Auroral Zone on 51.9 Mc/s—R. B. Dyce. (*J. geophys. Res.*, vol. 60, pp. 317-323; September, 1955.) At a site north of the accepted auroral-zone maximum, radar echoes on a frequency of 51.9 mc were readily obtained from the north, but practically none from the south; the range of the reflecting points was from 500 to 1,100 km. These results are in agreement with the theory of reflection by auroras suggested by Moore (*TRANS. IRE*, vol. AP-3, pp. 217-230; 1952.) and developed by Booker et al. (1986 of 1955), requiring near-perpendicularity of radio ray paths to the lines of the earth's magnetic field. On transmitting towards the south, across visible auroras on 51.7 mc propagation associated with aurora was almost nonexistent, as required by the theory.
- 551.594.6:621.396.11 430  
Measurement of the Arrival Angle of "Whistlers"—D. D. Crombie. (*J. geophys. Res.*, vol. 60, pp. 364-365; September, 1955.) It is suggested that Storey's theory on the origin of whistling atmospherics (142 of 1954) could be tested by determining their arrival angle by a phase-measurement method based on that of Ross et al (2804 of 1951), using a pair of antennas spaced 15 km apart along the direction of the horizontal component of the geomagnetic field.
- LOCATION AND AIDS TO NAVIGATION
- 621.396.93:621.396.677.3 431  
Design for Wide-Aperture Direction Finders—Benoit and Furlow. (See 330.)
- 621.396.932 432  
Explanation of Difficulties in Direction-Finding on Ships when using Short or Intermediate Wavelengths—G. Ziehm. (*Frequenz*, vol. 9, pp. 310-318; September, 1955.) [See 1045 of 1955 (Troost).]
- 621.396.933 433  
Air Navigation Facilities—H. S. Christensen. (*Proc. Radio Cl. Amer.*, vol. 32, pp. 3-8; 1955.) An outline of the method and equipment used in the U.S.A. for guiding and directing aircraft during flight, airport approach, and landing.
- 621.396.933 434  
Radio Nav aids—"Radiophare"—(*Wireless World*, vol. 61, pp. 576-577; December, 1955.) A comparison of the Decca and TACAN (125 of 1955) short-range radio-navigation systems.
- 621.396.96:551.578.1 435  
Airborne Weather-Surveillance Radar—(*Elect. J.*, vol. 155, pp. 546-548; August 12, 1955.) Description of commercially available equipment for installation in the nose of an aircraft. Operating wavelength is 5.6 cm for one type and 3.2 cm for another. The most important advantage for the pilot is the possibility of avoiding the center of a storm. (See also 1048 of 1955.)
- 621.396.96:621.317.763.029.64 436  
A Simplified Form of Microwave Interferometer for Speed Measurements—Court. (See 533.)
- 621.396.96:621.374.4:621.318.435 437  
Saturable-Reactor Frequency Divider—Court and Scollary. (See 359.)
- 621.396.96:621.396.11 438  
Determination of the Reflection Coefficient of the Sea, for Radar-Coverage Calculation, by an Optical Analogy Method—G. W. G. Court. (*Proc. Instn. elect. Engrs.*, Part B, vol. 102, pp. 827-830; November, 1955.) The problem of the reflection of radio waves from a rough sea surface is considered by analogy with the reflection of light waves from a ground-glass sur-

face. A typical radar vertical-coverage diagram derived by this method shows the effect of the variation of sea-surface conditions.

621.396.96:621.396.62 439

**On the Problem of Optimum Detection of Pulsed Signals in Noise**—A. H. Benner and R. F. Drenick. (*RCA Rev.*, vol. 16, pp. 461-479; September, 1955.) "A detection philosophy is introduced which distinguishes only the presence or absence of a pulsed signal, avoiding the designation of signal location. This so-called interval detector is formulated statistically as a composite hypothesis problem and solved by decision function theory. The optimum decision rule is derived, its superiority in principle to others is proven, and an illustrative mechanization is described. The explicit evaluation of this optimum relative to other detection procedures has been achieved only in special border cases, one of which is included as an example."

#### MATERIALS AND SUBSIDIARY TECHNIQUES

531.788.7 440

**Oscillographic Measurement of the Penning-Gauge Characteristics**—M. Varičak. (*J. sci. Instrum.*, vol. 32, pp. 346-348; September, 1955.) Optimum working conditions for the Penning vacuum gauge are readily attained by adjusting in accordance with an oscilloscope display of curves showing the variation of discharge current with magnetic field strength in the gauge.

535.215:537.311.33 441

**Infrared Quenching and a Unified Description of Photoconductivity Phenomena in Cadmium Sulfide and Selenide**—R. H. Bube. (*Phys. Rev.*, vol. 99, pp. 1105-1116; August 15, 1955.) An apparent paradox in the results presented by Rose (2002 of 1955) is discussed. A theoretical and experimental investigation shows that infrared quenching, "superlinear" photocurrent, and the particular temperature dependence photocurrent in CdS and CdSe may all be associated with the filling and emptying of a specific set of defect levels, as indicated by the location of the calculated Fermi level. Values are determined for the energy levels involved.

535.37:546.472.21 442

**Determination of Effective Cross-Sections of Capture and Recombination of Thermal Electrons in ZnS-Cu,Co Phosphors**—Syui Syui-Yun. (*C.R. Acad. Sci. U.R.S.S.*, vol. 103, pp. 585-588; August 1, 1955. In Russian.)

535.37:546.472.21 443

**Effects of Infrared on Emission of ZnS:Cu Phosphors**—K. Nakamura. (*J. phys. Soc. Japan*, vol. 10, pp. 715-716; August, 1955.) Hex-ZnS:Cu phosphors containing 0.009 per cent Ag, 2.5 per cent NaCl, and between 0 and 0.03 per cent Cu, excited at various temperatures between  $-25^{\circ}$  and  $+25^{\circ}\text{C}$  by ultraviolet radiation, show a spectral shift towards green under infrared illumination and towards blue under red light. These results are not consistent with Bube's conclusions (648 of 1951).

535.37:621.385.832 444

**Transparent Phosphor Coatings**—F. J. Studer and D. A. Cusano. (*J. opt. Soc. Amer.*, vol. 45, pp. 493-497; July, 1955.) Coatings of various materials have been deposited on glass surfaces by chemical reaction of the components in the vapor state. The most satisfactory material is ZnS, activated with As, Cu, Mn, P, or Zn. Under cathode-ray excitation, brightness values as high as 400 foot-lamberts are obtained at 20 kv and  $1 \mu\text{a}/\text{cm}^2$ . Under ultraviolet excitation the response is low.

535.376 445

**Reversible Impairment of Phosphors by**

**Positive Ions**—W. Berthold. (*Naturwissenschaften*, vol. 42, pp. 436-437; August, 1955.) The decrease of luminescence of a ZnS:AgZ phosphor bombarded by  $\text{H}_2^+$  ions and its recovery on subsequent excitation by electrons were studied using specially-gettered tubes with the screen deposited on a transparent conducting layer to facilitate photoelectric measurements. Under ionic bombardment the decrease of luminescence was first exponential and later in accordance with the expression  $1/(1+cNt)$ , where  $N$  is the number of bombarding ions per second and  $c$  is a parameter indicating the degree of impairment, its value depending on the energy of the bombarding ions. The recovery effect on subsequent electron bombardment varies inversely with the energy of the bombarding ions. The results indicate that part of the damage caused by the ions is permanent.

535.376 446

**Influence of Alternating Electric Fields on the Light Emission of some Phosphors**—I. T. Steinberger, W. Low, and E. Alexander. (*Phys. Rev.*, vol. 99, pp. 1217-1222; August 15, 1955.) Experiments were made with various ZnS and ZnS:CdS phosphors. The brightness wave-form during fluorescence consists of two different pulses per cycle; the pulses corresponding to positive polarity are similar for all phosphors, those corresponding to negative polarity differ. Mechanisms affording possible explanations of the observations are discussed.

537.22:549.514.5 447

**Adhesion and Charging of Quartz Surfaces**—W. R. Harper. (*Proc. roy. Soc. A.*, vol. 231, pp. 388-403; September 6, 1955.) Experiments are reported which indicate that the charging of quartz surfaces by each other results from different orientation with respect to the crystal axes.

537.226 448

**Conditions for Forming and Stability of [interface] Layers near Electrodes in Dielectrics**—Ya. N. Pershiits. (*Zh. eksp. teor. Fiz.*, vol. 28, pp. 181-190; February, 1955.) An experimental investigation is reported on layers with unidirectional conductivity formed at the electrode/dielectric interface, and of the effects on the properties of these layers of various heat pre-treatments and electric fields. The dielectrics included porcelain, eternit, mica, and asbestos; quartz and alkali halides were investigated earlier (*ibid.*, vol. 17, p. 251; 1947).

537.226/.227:546.48.882.5 449

**Specific Heat Anomaly of Ferroelectric Cadmium Niobate at the Curie Temperature**—H. R. Danner and R. Pepinsky. (*Phys. Rev.*, vol. 99, pp. 1215-1217; August 15, 1955.)

537.226.2:621.317.335.029.63 450

**Decimetre-Wavelength Measurements of the Dielectric Behaviour of Various Glases as a Function of their Water Content**—E. Deeg and O. Huber. (*Naturwissenschaften*, vol. 42, p. 507; September, 1955.)

537.226.31:549.514.51 451

**Dielectric Losses of Various Monocrystals of Quartz at Very Low Temperatures**—J. Volger, J. M. Stevels, and C. van Amerongen. (*Philips Res. Rep.*, vol. 10, pp. 260-280; August, 1955.) Measurements were made on (a) clear, (b) irradiated, and (c) naturally smoky quartz, and on (d) amethyst, at frequencies of 1 and 32 kc. Maxima exhibited by the dielectric-loss/temperature curve at temperatures between  $14^{\circ}$  and  $150^{\circ}\text{K}$  are related to lattice defects.

537.227:546.431.824-31 452

**Optical Observation of the First-Order Transition of Barium Titanate Single Crystal at the Curie Point**—A. Nishioka. (*J. phys. Soc. Japan*, vol. 10, pp. 535-540; July, 1955.)

537.227:546.431.824-31 453

**Thermal Transition of Transparency in Ferroelectric Single Crystal of Barium Titanate**—T. Horie, K. Kawabe, M. Tachiki and S. Sawada. (*J. phys. Soc. Japan*, vol. 10, pp. 541-549; July, 1955.)

537.227:546.431.824-31 454

**Electrical Behaviour of Barium Titanate Single Crystals at Low Temperatures**—H. H. Wieder. (*Phys. Rev.*, vol. 99, pp. 1161-1165; August 15, 1955.) Measurements were made over a temperature range including the phase transitions from tetragonal to orthorhombic at  $-5^{\circ}\text{C}$  and from orthorhombic to rhombohedral at  $-92^{\circ}\text{C}$ . As the temperature decreases through a transition, the coercivity, polarization-reversal time, and spontaneous polarization decrease discontinuously. Dielectric constant varies linearly with switching time; this supports the theory of a relaxation mechanism for polarization reversal.

537.228.1:538.569.4 455

**Radio-Frequency Absorption Spectra of [lattice] Vibrations of some Piezoelectric Solids**—J. Duchesne and A. Monfils. (*C. R. Acad. Sci., Paris*, vol. 241, pp. 749-750; September 19, 1955.) Data for Rochelle salt, quartz, and some organic substances of importance in biology are presented and discussed.

537.311.31 456

**Resistance of Metals at High Current Densities**—V. V. Bondarenko, I. F. Kvartskhava, A. A. Plyutto, and A. A. Chernov. (*Zh. eksp. teor. Fiz.*, vol. 28, pp. 191-198; February, 1955.) Results of an experimental investigation indicate that Ohm's Law is obeyed with an error of less than  $\pm 7$  per cent at current densities up to  $10^7 \text{ A}/\text{cm}^2$  in Cu, Ag, Pt, Al, W, and Fe at temperatures from a few tens of degrees C up to and beyond the melting point.

537.311.31+537.311.33]:539.16 457

**A Survey of Irradiation Effects in Metals**—J. W. Glen. (*Advances Phys.*, vol. 4, pp. 381-478; October, 1955.) Attention is confined to those changes which seem to be caused by disrupting the lattice of a solid without changing the nature of the molecules of which it is composed; the properties discussed include electrical conductivity, diffusion, and thermoelectricity. A brief survey of the effects of radiation on semiconductors is also included. Over 200 references.

537.311.33 458

**Theory of Equations of Transport in Strong Electric Fields**—I. M. Tsidi'kovski and F. G. Bass. (*Zh. eksp. teor. Fiz.*, vol. 28, p. 245; February, 1955.) Brief critical comment on 3519 of 1954 (Avak'yants). (Note: The original author's name was previously given erroneously as Abak'yants.)

537.311.33 459

**To intensify the Study of Semiconductor Electronics**—A. Ioffe. (*Radio, Moscow*, no. 8, pp. 4-7; August, 1955.) Includes short summaries of papers on semiconductor physics read at the April, 1955, meeting of the physico-mathematical section of the U.R.S.S. Academy of Sciences.

537.311.33 460

**Graphical Treatment of Degeneracy in an Intrinsic Semiconductor**—G. Busch. (*Helv. phys. Acta*, vol. 28, pp. 320-321; August 31, 1955. In German.) [See also 1453 of 1954 (Mooser).]

537.311.33 461

**Recombination of Injected Carriers at Dislocation Edges in Semiconductors**—J. P. McKelvey and R. L. Longini. (*Phys. Rev.*, vol. 99, pp. 1227-1232; August 15, 1955.) "The boundary conditions for carrier recombination at a



lineage boundary in a semiconductor in the presence of a constant electric field are derived from kinetic considerations. A non-recombination probability, or "transmission coefficient"  $T$  for a single charge carrier is assumed initially, and "recombination velocities" at the lineage boundary are expressed in terms of this quantity. A simple experiment to determine the transmission coefficient is suggested. The relationship between the transmission coefficient and the cross section for recombination is investigated, . . ."

537.311.33:538.2 462

**Relation of Magnetic Structure to Electrical Conductivity in NiO and Related Compounds**—R. R. Heikes. (*Phys. Rev.*, vol. 99, pp. 1232-1234; August 15, 1955.) "A qualitative theory is presented in an effort to understand the insulating properties of NiO. If one generalizes this theory to include all stoichiometric binary compounds, having a transition element as cation and an element from group V or VI as anion, a rather startling correlation between the magnetic and electric properties is predicted. Ferromagnetic compounds should be good conductors with a positive temperature coefficient of resistivity while antiferromagnets should be insulators with a negative temperature coefficient of resistivity. The available data indicate that this correlation does exist."

537.311.33:546.26-1 463

**Preliminary Study of the Electrical Properties of a Semiconducting Diamond**—J. J. Brophy. (*Phys. Rev.*, vol. 99, pp. 1336-1337; August 15, 1955.)

537.311.33:[546.28+546.289] 464

**Hot Electron Problem in Semiconductors with Spheroidal Energy Surfaces**—M. Shibuya. (*Phys. Rev.*, vol. 99, pp. 1189-1191; August 15, 1955.) The "hot-electron" problem, so named by Shockley (1011 of 1952), deals with departures from Ohm's law in semiconductors in strong electric fields. Discrepancies between experimental and theoretical results for Si and Ge are reduced by taking account of ellipsoidal energy surfaces in the Brillouin zone and of scattering by shear modes of vibration.

537.311.33:[546.28+546.289] 465

**Intrinsic Optical Absorption in Single-Crystal Germanium and Silicon at 77°K and 300°K**—W. C. Dash and R. Newman. (*Phys. Rev.*, vol. 99, pp. 1151-1155; August 15, 1955.) Absorption is assumed to take place by direct and indirect transitions; values of the energy thresholds corresponding to these transitions are estimated from the absorption spectra.

537.311.33:546.289 466

**Dislocations in Germanium**—S. G. Ellis. (*J. appl. Phys.*, vol. 26, pp. 1140-1146; September, 1955.) A microscope study of etched Ge crystals is reported, with photographic illustrations. Crystal dislocations forming networks are general; screw dislocation with large Burgers vectors are observed in some cases.

537.311.33:546.289 467

**Rate-Grown Germanium Crystals for High-Frequency Transistors**—H. E. Bridgers and E. D. Kolb. (*J. appl. Phys.*, vol. 26, pp. 1188-1189; September, 1955.) The production of  $n$ - $p$ - $n$  crystals for experimental tetrode transistors oscillating at frequencies  $>1$  kmc is described. Boron, with a segregation coefficient  $>1$ , is used as an acceptor impurity.

537.311.33:546.289 468

**Fast Neutron Bombardment of p-Type Germanium**—J. W. Cleland, J. H. Crawford, Jr. and J. C. Pigg. (*Phys. Rev.*, vol. 99, pp. 1170-1181; August 15, 1955.) An extensive experimental investigation has been made. Analysis of the observed conduction indicates that the bombardment introduces three vacant states below the middle of the forbidden band.

Changes observed after prolonged bombardment or room-temperature aging are discussed. Some bombardments were performed at temperatures from  $-165^\circ$  to  $-90^\circ\text{C}$ ; complex relaxation effects were observed on warming. (See also 3647 of 1955.)

537.311.33:546.289 469

**Properties of Grain Boundaries in Gold-Doped Germanium**—A. G. Tweet. (*Phys. Rev.*, vol. 99, pp. 1182-1189; August 15, 1955.) Measurements were made of the variation of Hall effect with temperature in high-resistivity specimens of Au-doped Ge containing grain boundaries of known orientation; a new permanent-magnet apparatus used for the measurements is described. The results indicate the existence of a path of relatively low resistivity along the grain boundary, such as would be produced by an array of acceptor levels. A tentative explanation of the observed phenomena is based on Bardeen's theory of surface states (3086 of 1947). (See also *ibid.*, pp. 1245-1248.)

537.311.33:546.289 470

**Hall Effect and Density of States in Germanium**—E. M. Conwell. (*Phys. Rev.*, vol. 99, pp. 1195-1198; August 15, 1955.) An analysis is made of corrections required in calculations of activation energy of impurities, and of density of states, to take account of known complexities in the energy-band structure.

537.311.33:546.289 471

**Avalanche Breakdown in Germanium**—S. L. Miller. (*Phys. Rev.*, vol. 99, pp. 1234-1241; August 15, 1955.) Results of experiments support theory presented by Wolff (746 of 1955).

537.311.33:546.289 472

**Magnetic Indications of Electronic Structure of the Conduction Band in Ge**—J. H. Crawford, Jr., H. C. Schweinler, and D. K. Stevens. (*Phys. Rev.*, vol. 99, pp. 1330-1331; August 15, 1955.) Data on the magnetic susceptibility of the charge carriers afford a means of deciding whether the energy surfaces in the conduction band of Ge are best represented by four or eight ellipsoids.

537.311.33:546.289 473

**Methods for revealing P-N Junctions and Inhomogeneities in Germanium Crystals**—J. I. Pankove. (*RCA Rev.*, vol. 16, pp. 398-402; September, 1955.) Various methods are described involving etching during immersion in an electrolyte.

537.311.33:546.289.536.21 474

**Thermal Conductivity of Germanium at Ambient Temperatures**—K. A. McCarthy and S. S. Ballard. (*Phys. Rev.*, vol. 99, p. 1104; August 15, 1955.) Measurements over the temperature range  $5^\circ$ - $95^\circ\text{C}$  are reported; the thermal conductivity varies approximately linearly over this range.

537.311.33:546.289.539.3 475

**The Determination of the Elastic Constants of Germanium by Diffuse X-Ray Reflexion**—S. C. Prasad and W. A. Wooster. (*Acta cryst., Camb.*, vol. 8, Part 8, pp. 506-507; August 10, 1955.)

537.311.33:546.289:621.383.5 476

**Influence of Diffusion Length and Surface Recombination on the Barrier-Layer Photoelectric Effect in Germanium**—Harten and Schultz. (See 614.)

537.311.33:546.682.86:538.63 477

**On the Galvanomagnetic Effects in  $n$ -Type Indium Antimonide**—Y. Kanai. (*J. phys. Soc. Japan*, vol. 10, pp. 718-719; August, 1955.) Because of the high charge-carrier mobility  $\mu$  of InSb, usual theory valid for  $\mu H \ll 10^8$  is expected not to apply above a certain value of

field strength  $H$ . Hall coefficient and the magnetoresistance effect were investigated at field strengths up to 9 kg, at temperatures of the order of  $-150^\circ\text{C}$ . The Hall coefficient was constant and independent of field strength; the magnetoresistance variations were inconsistent with the usual theory. The results are consistent with quantization of the electron orbit.

537.311.33:546.811-17 478

**Manganese Impurity Centres in Grey Tin**—G. Busch and K. A. Müller. (*Helv. phys. Acta*, vol. 28, pp. 319-320; August 31, 1955.) Measurements of Hall effect in several samples at temperatures between  $90^\circ$  and  $260^\circ\text{K}$  give results consistent with the conclusion reached previously by Busch and Moser (1476 of 1954) that the Mn is incorporated in lattice sites in  $\alpha$ -Sn. The solubility of Mn in grey tin is considerably greater than in Ge.

537.311.33+535.215]:546.863.221 479

**Photoconductivity of Stibnite ( $\text{Sb}_2\text{S}_3$ )**—S. Ibuki and S. Yoshimatsu. (*J. phys. Soc. Japan*, vol. 10, pp. 549-554; July, 1955.) Experimental results indicate that stibnite is an  $n$ -type semiconductor. The peak spectral sensitivity at room temperature occurs at a wavelength of  $770\text{ m}\mu$ , the thermal activation energy determined from the temperature variation of the dark current between room temperature and  $200^\circ\text{C}$  is 0.48 ev, and the response time-lag is about 3 ms for variations of photocurrent around a steady value of  $10\text{ }\mu\text{a}$ . The results are presented graphically.

537.311.33:621.396.822 480

**Phenomenological Approach to "Current Noise"**—D. A. Bell. (*Brit. J. appl. Phys.*, vol. 6, pp. 284-287; August, 1955.) Available experimental data on current noise in semiconductors are reviewed. The noise is associated with bulk conductivity rather than with contact phenomena. The inverse-frequency spectrum could be due either to a complicated diffusion process or, more probably, to the law relating mean-square perturbation and time for the whole population of carriers which is not to be regarded as an equilibrium system.

538.221 481

**On an Empirical Formula for the Ferromagnetic Anisotropy Constant in Cubic Crystals**—M. Yamamoto. (*J. phys. Soc. Japan*, vol. 10, pp. 725-726; August, 1955.) Values derived from a formula presented previously (1077 of 1955) are compared with values found experimentally for Ni-Co and Ni-Cu alloys.

538.221 482

**Effect of Nitrides on the Coercive Force of Iron**—J. Kerr and C. Wert. (*J. appl. Phys.*, vol. 26, pp. 1147-1151; September, 1955.) Measurements indicate that the effect of including flat particles of nitride is most marked for particles whose largest dimensions are comparable with domain-wall thickness.

538.221 483

**On the Loss of Texture in Tapes of a 50 Pct Ni-50 Pct Fe Alloy**—S. Spachner and W. Rostoker. (*J. Metals*, N. Y., vol. 7, pp. 921-922; August, 1955.) Comparison of the crystal structures of annealed tapes of thickness  $2.1, \frac{1}{2}, \frac{1}{4}$ , and  $\frac{1}{8}$  mil indicates loss of the characteristic texture associated with a square hysteresis loop at thicknesses  $<1$  mil. No explanation of the effect is yet established.

538.221 484

**The Smallest Size of Weiss-Heisenberg Domains in Cobalt**—A. Knappest. (*Naturwissenschaften*, vol. 42, p. 459; August, 1955.) A brief discussion indicates a volume equivalent to a cube of side about  $16\text{ \AA}$  as the smallest volume for spontaneously magnetized domains in Co. A full account is to be published in *Z. phys. Chem.*

- 538.221 485  
Theory of Néel's Spikes and of the Coercive Force associated with the Development of Tubular Secondary Domains ("Schlauchziehen")—R. Brenner. (*Z. angew. Phys.*, vol. 7, pp. 391-397; August, 1955.)
- 538.221:538.569.4.029.6 486  
Frequency Dependence of Magnetic Resonance in  $\alpha\text{-Fe}_2\text{O}_3$ —H. Kumagai, H. Abe, K. Ono, I. Hayashi, J. Shimada, and K. Iwanaga. (*Phys. Rev.*, vol. 99, pp. 1116-1118; August 15, 1955.) Measurements in the wavelengths range 5.4 mm-6.2 cm are reported.
- 538.221:538.632 487  
Hall Effect in Permalloys—S. Foner. (*Phys. Rev.*, vol. 99, pp. 1079-1081; August 15, 1955.) Results of measurements on two different permalloys are compared with results on other alloys and are discussed in relation to the band structure of the materials.
- 538.221:546.73.241 488  
Magnetic Properties of Cobalt Telluride—E. Uchida. (*J. phys. Soc. Japan*, vol. 10, pp. 517-522; July, 1955.) Experimental results presented indicate that the magnetic properties of this compound are closely similar to those of MnAs. The saturation magnetization is 7.52 G/g.
- 538.221:621.318.134 489  
Magnetic Ferrites with Perminvar-Type [hysteresis] Loops—M. Kornetzki, J. Brackmann, and J. Frey. (*Naturwissenschaften*, vol. 42, p. 482; September, 1955.) Ni and Ni-Zn ferrites with small additions of MnO and CoO exhibit the hysteresis-loop constriction characteristic of perminvar. If these ferrites are cooled slowly in a magnetic field, a rectangular hysteresis loop is obtained. A full account of the work is to be published in *Siemens-Z.*
- 538.221:621.318.134 490  
The Behaviour of Ferrite Cores with Rectangular Magnetization Loop in a Nonuniform Magnetic Field or when provided with Gaps—M. Kornetzki and H. Burger. (*Frequenz*, vol. 9, pp. 306-309; September, 1955.) Measurements are reported on MgMn-ferrite toroidal cores with (a) relatively small internal diameters, (b) nonuniform cross-sections, or (c) gaps. Where only a high remanence value is important, slight nonuniformities thus introduced are tolerable; highly rectangular loops can only be obtained with thin, continuous cores, but some nonuniformity of cross-section is tolerable. The results indicate that the rectangular loop in ferrites is a consequence of numerous individual magnetization reversals occurring within a narrow range of magnetic-field values.
- 538.221:621.318.134 491  
Ferromagnetic Resonance in Magnesium-Manganese Aluminum Ferrite between 160 and 1900 Mc/s—H. Suhl, L. G. Van Uitert, and J. L. Davis. (*J. appl. Phys.*, vol. 26, pp. 1180-1182; September, 1955.) Measurements are reported on a disk specimen of stated composition magnetized normal to its plane. Graphs show the variation of resonance frequency with applied field, and the variation of  $\mu''$  with applied field at 310 and 843.64 mc.
- 538.221:621.318.134:538.569.4 492  
Ferromagnetic Resonance in Two Nickel-Iron Ferrites—W. A. Yager, J. K. Galt, and F. R. Merritt. (*Phys. Rev.*, vol. 99, pp. 1203-1210; August 15, 1955.) Further observations of (a) the variation of resonance field-strength with crystal orientation, and (b) the variation of the width of the resonance line as a function of temperature, support the conclusions reached previously [2446 of 1954 (Galt et al.)] regarding the mechanism producing losses in ferrites.
- 538.221:621.318.134:538.6 493  
Peculiarities of the Faraday Effect in Paraffin-Ferrite Mixtures—V. A. Fabrikov. (*C.R. Acad. Sci. U.R.S.S.*, vol. 103, pp. 807-809; August 11, 1955. In Russian.) The Faraday effect was investigated at frequencies between 2.2 and 3 kmc at magnetic field strengths up to 1,500 oersted, using disks of paraffin-ferrite mixture with a typical composition 70 per cent paraffin, 16 per cent Ni-Zn ferrite, and 14 per cent rutile, added to increase the dielectric constant. The rotation of the plane of polarization was in a sense opposite to that observed in ferrite disks. The rotation was found to depend on the dimensions of the disks, the field strength, the frequency and the concentration of the ferrites in the mixture. The results are discussed on the basis of theories of the permeability tensor of ferromagnetics.
- 538.221:621.318.134:538.652 494  
Magnetostriction and Permeability of Magnetite and Cobalt-Substituted Magnetite—L. R. Bickford, Jr., J. Pappis, and J. L. Stull. (*Phys. Rev.*, vol. 99, pp. 1210-1214; August 15, 1955.) Measurements are reported for ferrites of various compositions at temperatures from 120° to 300°K. The substitution of small amounts of Co for divalent Fe produces an upward shift in the temperature at which maximum initial permeability occurs; this maximum is always associated with a change in the direction of easy magnetization.
- 538.221:621.318.134:621.372.413 495  
Measurement of Susceptibility Tensor in Ferrites—J. O. Artman and P. E. Tannenwald. (*J. appl. Phys.*, vol. 26, pp. 1124-1132; September, 1955.) (769 of 1954.) Detailed description of technique outlined previously in which a determination is made of the perturbation produced in cavity resonators by introducing ferrite specimens. Measurements on ferramic 1331 at 9.165 kmc are reported. Experimental results are discussed in relation to magnetic resonance theory.
- 538.221:621.395.625.3 496  
Remanence Curve of Single-Domain Ferromagnetic Particles: Application to the Coatings of Sound-Recording Tapes—E. P. Wohlfarth. (*Research, Lond.*, vol. 8, Supplement, pp. S42-S44; August, 1955.) An investigation is made of the dependence on applied field strength of the remanent magnetization of an assembly of randomly oriented particles with uniaxial anisotropy. There is some evidence that the characteristic curve of acicular particles is more suitable than that of nonacicular particles for purposes of magnetic recording.
- 538.221:681.142 497  
Ferromagnetic Computer Cores—C. F. Devenny, Jr., and L. G. Thompson. (*Tele-Tech & Electronic Ind.*, vol. 14, pp. 58-59, 94; September, 1955.) Recent improvements in the properties of rectangular-hysteresis-loop cores are illustrated by characteristic curves relating to 4-79 permalloy and 48 per cent Ni-Fe alloy tape cores.
- 538.23 498  
Reversible and Irreversible Magnetization Changes along the Hysteresis Loop—M. Kersten. (*Z. angew. Phys.*, vol. 7, pp. 397-407; August, 1955.) The review presented refers mainly to the physics of the quasistatic hysteresis loop. 37 references include seven to other recent reviews.
- 538.23 499  
Theory of Hysteresis Losses in the Rotating Magnetic Field—M. Kornetzki and I. Lucas. (*Z. Phys.*, vol. 142, pp. 70-82; August 27, 1955.) Experimental evidence indicates that hysteresis losses in a weak rotating field are greater, while those in a strong rotating field are smaller, than in an alternating field of the same strength. This is explained on the basis of Bloch-wall movements at low field strength; these walls disappear at high field strength.
- 546.87:538.632 500  
Dependence of Hall Effect in Bismuth on Pressure—L. F. Vereshchagin and A. I. Likhiter. (*C. R. Acad. Sci. U.R.S.S.*, vol. 103, pp. 791-794; August 11, 1955.) Measurements are reported at pressures up to 10,000 kg/cm<sup>2</sup> in magnetic fields up to 10,000 oersted; the Hall emf decreases with increasing pressure.
- 621.315.612 501  
Materials used in Radio and Electronic Engineering Ceramics—(*J. Brit. Instn. Radio Engrs.*, vol. 15, pp. 506-517; October, 1955.) A survey including tables of properties of various classes of ceramics and 111 references.
- 621.315.612.6:538.569.4 502  
Paramagnetic Resonance Absorption in Glass—R. H. Sands. (*Phys. Rev.*, vol. 99, pp. 1222-1226; August 15, 1955.)
- 621.372.412.002.2:549.514.51 503  
Vacuum-Plating Equipment for the Manufacture of Quartz Resonators—H. Awender, E. Becker, and K. Sann. (*Telefunken Ztg.*, vol. 28, pp. 34-38; March, 1955. English summary, pp. 60-61.) Three receptacles on a turntable are (a) charged with crystal and evaporation metal, (b) roughly evacuated, (c) connected to oil diffusion pumps. Beneath each receptacle is an oscillatory circuit. When the nominal frequency of the crystal is attained the evaporation is interrupted by a magnetically actuated shutter. The frequency range covered is 50 kc-70 mc.
- 537.311.33 504  
Elektronische Halbleiter [Book Review]—E. Spenke. Publishers: Springer, Berlin, 379 pp.; 1955. (*Naturwissenschaften*, vol. 42, p. 448; August, 1955.) An authoritative introduction to the physical bases of dry rectifiers and transistors.

## MATHEMATICS

- 51 505  
On Perturbation Methods involving Expansions in Terms of a Parameter—R. Bellman. (*Quart. appl. Math.*, vol. 13, pp. 195-200; July, 1955.) The effectiveness of the method of expanding a solution of an equation in a power series in terms of a parameter may in many cases be greatly increased by expanding in terms of a suitably chosen function of the parameter; this is particularly the case when only positive values of the parameter enter. Examples treated to illustrate the method include van der Pol's equation.
- 512 506  
Solution of Quartic Equations—E. Astuni. (*Ricerca sci.*, vol. 25, pp. 2295-2312; August, 1955.) A method is described similar to that used for solving cubic equations (194 of January).
- 517 507  
Confluent Hypergeometric Functions—F. G. Tricomi. (*Z. angew. Math. Phys.*, vol. 6, pp. 257-274; July 25, 1955.) Discussion of a class of functions by means of which second-order linear differential equations can be integrated in closed form.
- 517:538.566 508  
Asymptotic Expansions of Solutions of  $(\nabla^2+k^2)u=0$ —Friedlander and Keller. (See 398.)
- 517.621.396.822 509  
On Middleton's Paper "Some General Results in the Theory of Noise Through Non-linear Devices"—J. S. Shipman. (*Quart. appl. Math.*, vol. 13, pp. 200-201; July, 1955.) The hypergeometric functions in Middleton's formulas (3238 of 1948) can in some cases be reduced to polynomials or combinations of complete elliptic integrals which are special cases of "Bennett functions" tabulated by Sternberg et al. (1779 of June).

- 518.3 **Three-Dimensional Nomograms**—D. P. Adams. (*Product Engng.*, vol. 26, pp. 186-191; August, 1955.)
- 517 **Mathieu'sche Funktionen und Sphäroidfunktionen** [Book Review]—J. Meixner and F. W. Schäfer. Publishers: Springer, Berlin, 414 pp.; 1954. (*Z. angew. Phys.*, vol. 7, p. 408; August, 1955.)
- 517(083.5) **Tables des Fonctions de Legendere Associées, Calculées pour le Centre National d'Études des Télécommunications** [Book Review]—Publishers: Édition de la Revue d'Optique, Paris, 291 pp; 1952. (*Z. angew. Math. Phys.*, vol. 6, p. 344; July 25, 1955.) The tables presented are useful for the numerical solution of potential problems in spherical coordinates.
- MEASUREMENTS AND TEST GEAR**
- 531.761+529.7 **Definition of the Second of Time**—H. S. Jones. (*Nature, Lond.*, vol. 176, pp. 669-670; October 8, 1955.) The relations between the value of the second as defined by the International Astronomical Union [200 of January (Essen)], the value corresponding to the Universal time system and that corresponding to the Cs standard [3686 of 1955 (Essen et al.)] are discussed. When the relation between the mean solar second at the present time and the second as newly defined has been satisfactorily determined it will be possible immediately to relate the mean solar second to the fundamental unit of time by means of the Cs standard.
- 621.3.018.41(083.74)+621.396.91 **Standard Frequency Transmissions**—L. Essen. (*Proc. Instn. elect. Engrs.*, Part B, vol. 102, pp. 825-826; November, 1955.) Discussion on 3289 of 1954.
- 621.3.018.41(083.74) **Standard Frequency Transmission Equipment at Rugby Radio Station**—H. B. Lav. (*Proc. Instn. elect. Engrs.*, Part B, vol. 102, pp. 825-826; November, 1955.) Discussion on 1724 of 1955.
- 621.3.018.41(083.74):621.317.761 **The Standard Frequency Monitor at the National Physical Laboratory**—J. McA. Steele. (*Proc. Instn. elect. Engrs.*, Part B, vol. 102, pp. 825-826; November, 1955.) Discussion on 1725 of 1955.
- 621.317.3:621.3.018.75(083.74) **IRE Standards on Pulses: Methods of Measurement of Pulse Quantities, 1955**—(PROC. IRE, vol. 43, Part 1, pp. 1610-1616; November, 1955.) Standard 55 IRE 15. SI.
- 621.317.32.024 **A Superconducting Modulator**—I. M. Templeton. (*J. sci. Instrum.*, vol. 32, pp. 314-315; August, 1955.) "A new type of dc amplifier for use at liquid helium temperatures, based on a magnetically modulated tantalum wire, is described. The input impedance is approximately  $10^{-3}\Omega$ , and noise figures down to approximately  $2 \times 10^{-11}$ v are fairly easily obtained. The application of this instrument as a null detector for the measurement of very small voltages in a liquid helium bath is described."
- 621.317.328.029.64 **A New Perturbation Method for measuring Microwave Fields in Free Space**—A. L. Cullen and J. C. Parr. (*Proc. Instn. elect. Engrs.*, Part B, vol. 102, pp. 836-844; November, 1955.) "A short thin metal rod forms the perturbing element. In order to avoid confusing the reflection from this rod with unwanted reflection the rod is arranged to spin about an axis perpendicular to its length. The perturbation of the field at the source is therefore modulated at a characteristic frequency, and by using an ac amplifier, steady reflections can be eliminated. The apparatus described operates at a wavelength of about 3.2 cm. Experimental results are given which verify the theory for linearly polarized waves. Extension of the method to elliptically polarized waves is possible in principle, but inherent ambiguities may be troublesome in practice."
- 621.317.33:621.315.612.6 **Measurement of Electrical Resistance of Water and Solutions**—A. G. Manikonov. (*Bull. Acad. Sci. U.R.S.S., sér. tech. Sci.*, no. 3, pp. 154-159; March, 1955. In Russian.) Results are reported of If measurements on 0.1 N-1.0 N solutions of NaCl, CuSO<sub>4</sub>, Na<sub>2</sub>SO<sub>4</sub>, and KCl, and on sea-water. The effective capacitance with sea-water was independent of the distance between the electrodes and of the presence of sand, but did vary with the concentrations of the solutions.
- 621.317.331:621.315.612.6 **A Simple D.C. Method for the Determination of the Electrical Resistance of Glass**—H. E. Taylor. (*J. Soc. Glass Tech.*, vol. 39, pp. 193T-204T; August, 1955.) A method suitable at the low current densities obtained at room temperature is based on use of a pH meter. Resistivities from  $10^8$  to  $10^{16}$   $\Omega$ .cm are measurable.
- 621.317.337 **A Q Meter method of Measuring Very Low Reactance at High Frequencies**—J. P. Newsome. (*Electronic Engng.*, vol. 27, pp. 494-498; November, 1955.) A method due to Lafferty (*Electronics*, vol. 24, p. 126; November, 1951) is developed. Details are given of a circuit designed to measure the reactance of inductances as low as 0.003  $\mu$ h at 1 mc.
- 621.317.337:621.372.412 **A New Method of determining the Quality Factor "Q" of Piezoelectric Crystals**—H. Mayer. (*Onde Elect.*, vol. 35, pp. 692-699; July, 1955.) A fuller account of work described previously (2508 of 1955).
- 621.317.361 **Designing a Precision Frequency-Measuring System**—A. S. Bagley and D. Hartke. (*Tele-Tech & Electronic Ind.*, vol. 14, pp. 84-85, 142; August, 1955.) By combining a transfer oscillator and frequency converter with a standard high-speed frequency counter the range from zero frequency to 12.4 kmc is covered with an accuracy within 1 part in  $10^6$ .
- 621.317.382.029.64 **The Measurement of Power at a Wavelength of 3 cm by Thermistors and Bolometers**—J. A. Lane. (*Proc. Instn. elect. Engrs.*, Part B, vol. 102, pp. 819-824; November, 1955.) "A description is given of measurements made on several thermistors and bolometers at wavelengths of 3.18 and 3.26 cm, using a water calorimeter to investigate their performance as indicators of absolute power. The calorimeter, details of which are given, was designed to measure powers of 2-5 watts; and by means of a 35 db directional coupler known absolute powers at the milliwatt level were delivered to the thermistor and bolometer mounts. Values of efficiency, defined as the ratio of the power measured in a dc calibration to the net input power, of 0.87 to 0.91 were found, with no significant change on varying the operating resistance of the thermistors and bolometers over the range 150-300 ohms."
- 621.317.7:621.314.7 **Simplified Transistor Test Equipment**—A. D. Bentley, S. K. Ghandi, and V. P. Mathis. (*Tele-Tech & Electronic Ind.*, vol. 14, pp. 56-57, 120; September, 1955.) The short-circuit current-amplification factor of p-n-p junction transistors is measured by means of a battery-operated single-meter instrument, a 10- $\mu$ a drop in base current being used as a step-waveform input signal.
- 621.317.7:621.396.822 **Direct-Reading Noise-Figure Indicator**—C. E. Chase. (*Electronics*, vol. 28, pp. 161-163; November, 1955.) An instrument for measurements on traveling-wave tubes etc. comprises a noise source modulated by a 60 cps square wave, the noise figure being given by the noise-source power less the difference in db between the modulated and unmodulated output components, assuming linear amplification and quadratic detection. A special feature is the use of simple circuits to take the logarithms of these two voltages and derive their difference, giving an indication which is linear on a db scale.
- 621.317.725 **Square-Law Detector for R.M.S. Voltages**—J. W. Sauber. (*Electronics*, vol. 28, pp. 170-172; November, 1955.) A voltmeter of amplifier-detector type is described in which an approximately parabolic characteristic consisting of linear segments is obtained by use of a series arrangement of biased Ge diodes. The voltage range is up to 320 v, the frequency range is from 5 cps to 500 kc.
- 621.317.733:621.373.5+621.375.4 **Low-Cost, Battery-Operated Oscillators and Detectors for A.C. Bridges**—M. D. Armitage. (*J. sci. Instrum.*, vol. 32, pp. 300-302; August, 1955.) A transistor oscillator with an output of 1 v across 1,000  $\Omega$  and a transistor transformer-coupled amplifier detector which will detect 0.01 mv are described; complete circuit diagrams are given.
- 621.317.75 **The Writing Speed of Light-Beam Oscillographs**—W. Härtel. (*Frequenz*, vol. 9, pp. 319-324; September, 1955.) The performances of cathode-ray and light-beam oscillographs are compared; the maximum writing speed of the latter type is about 1.5 km.
- 621.317.75.088 **The Accuracy of Estimation of Oscillograms**—W. Härtel. (*Frequenz*, vol. 9, pp. 264-273; August, 1955.) Discussion of errors in estimating photographed curves. due to inaccuracy of the observer rather than of the measurement apparatus.
- 621.317.755:537.52 **The Plasmograph, a New Instrument for studying Periodically Variable Electric Discharges**—R. Ledrus, M. Hoyaux, and A. Vanavermaete. (*Rev. gén. Élect.*, vol. 64, pp. 391-403; August, 1955.) Description of a cro instrument based on application of the theory of the Langmuir probe.
- 621.317.763.029.64:621.396.96 **A Simplified Form of Microwave Interferometer for Speed Measurements**—G. W. G. Court. (*J. sci. Instrum.*, vol. 32, pp. 354-356; September, 1955.) The instrument described is suitable for the determination of the Doppler frequency shift due to the motion of a target. One antenna is used and a hybrid ring junction separates the transmitting and receiving paths, leakage from the transmitter providing local-oscillator power for the receiver.
- 621.317.784.029.62 **A Wide-Band V.H.F. Wattmeter**—T. Takahashi and M. Arai. (*J. Radio Res. Labs, Japan*, vol. 2, pp. 99-105; January, 1955.) A resistance-loop directional coupler working through a coaxial line into a sensitive square-law valve voltmeter shunted by a variable capacitance is used to measure power in a transmission line. Wide-band characteristics are achieved by careful design of the coupler to secure that its resistance does not vary with frequency and

by compensation in the measuring circuit for the variation of coupling coefficient with frequency. The instrument described measures power up to 60 w with an accuracy within 5 per cent over the frequency range 30–200 mc.

**621.317.794:621.396.822** 535  
**A Comparison of Two Radiometer Circuits**—S. J. Goldstein, Jr. (PROC. IRE, vol. 43, Part 1, pp. 1663–1666; November, 1955.) A comparison is made between Dicke's method of measuring noise radiation (475 of 1947) and the method based on absence of correlation in noise received by two independent receivers. Expressions are derived for the weakest detectable signal in both methods; the two-receiver method is the more sensitive.

#### OTHER APPLICATIONS OF RADIO AND ELECTRONICS

**535.24-1.08.7:621.383.4** 536  
**Portable Radiation Detectors Employing Photoconductive Cells**—J. C. S. Richards. (*J. sci. Instrum.*, vol. 32, pp. 340–343; September, 1955.) The design of battery-operated infrared-radiation detectors is discussed. Use of an electromagnetically maintained vibrating-reed shutter for chopping the incident radiation leads to an acceptable signal/noise ratio.

**621.3.078(47):016** 537  
**List of U.S.S.R. Literature on Automatic Regulation and Related Problems for 1954**—(*Avtomatika i Telemekhanika*, vol. 16, pp. 219–224, 317–320; March/April and May/June, 1955.) A bibliography of about 250 papers.

**621.384.612** 538  
**The Glasgow 340-MeV Synchrotron**—W. McFarlane, S. E. Barden, and D. L. Oldroyd. (*Nature, Lond.*, vol. 176, pp. 666–669; October 8, 1955.) Illustrated description of a machine in use for experiments on the photo-disintegration of nuclei and for meson physics.

**621.385.833** 539  
**The Lower Limit of the Aperture Error in Magnetic Electron Lenses**—W. Tretner. (*Optik, Stuttgart*, vol. 12, p. 293; 1955.) Correction to paper abstracted in 236 of January.

**621.385.833** 540  
**A Compact Console-Type Electron Microscope**—R. S. Page. (*Metrop. Vick. Gaz.*, vol. 26, pp. 248–254; August, 1955.) Description of the Type-EM4 model, a general-purpose instrument which can be used for reflection electron microscopy with non-ferrous specimens, as well as for the transmission type of record.

#### PROPAGATION OF WAVES

**621.396.11** 541  
**Propagation of Electromagnetic Waves over a Flat Earth across a Boundary separating Different Media, and Coastal Refraction**—K. Furutsu. (*J. Radio Res. Labs., Japan*, vol. 2, pp. 1–49; January, 1955.) The general equation is formulated for vertically polarized waves in three-dimensional space, based on the Hertz vector, the analysis being valid for the case when the horizontally polarized wave induced at the boundary is negligible. A more general formulation is given in an appendix. The results are essentially the same as those obtained by Clemmow (3688 of 1953) for two-dimensional space. The refraction angle at a coast line is determined and the treatment is extended to propagation across successive lines of discontinuity.

**621.396.11** 542  
**Measurement of Field Intensity of Ground Wave over Mixed Paths**—Y. Aono and K. Muramatsu. (*J. Radio Res. Labs., Japan*, vol. 2, pp. 51–58; January, 1955.) Observations on frequencies from 1.85 to 4 mc over mixed country near Tokyo, including both land and

water, gave results in accordance with the theory of Furutsu (541 above).

**621.396.11** 543  
**Automatic Recording of the Direction of Arrival of Radio Waves reflected from the Ionosphere**—J. A. Thomas and R. W. E. McNicol. (*Proc. Instn. elect. Engrs.*, Part B, vol. 102, pp. 793–799; November, 1955.) The direction of arrival of 2.28 mc echoes was measured using technique based on that of Ross et al. (2804 of 1951) and modified to record automatically the direction of arrival of all the resolved echoes. Signals proportional respectively to the vector sum and difference of the signals induced in two spaced antennas were amplified in separate receivers and the rectified outputs were displayed on a cro whose timebase was synchronized with the transmitter pulses. The display was photographed with successive 3-minute exposures. The system was stable enough to run without attention for a week. Typical records are reproduced.

**621.396.11:550.372** 544  
**Variations of the Phase Constant of the Ground Wave**—M. Argirovic. (*Onde elect.*, vol. 35, pp. 687–691; July, 1955.) Analysis presented previously (3687 of 1953) is extended to deal with propagation at frequencies higher than those used for broadcasting. Curves are presented showing the variation of the field strength and of the equivalent phase constant with distance for different values of ground constants and frequency.

**621.396.11:551.510.5** 545  
**On the Propagation of the Electromagnetic Waves in an Inhomogeneous Atmosphere**—Y. Nomura and K. Takaku. (*J. phys. Soc. Japan*, vol. 10, pp. 700–714; August, 1955.) A rigorous solution is obtained of Maxwell's equations for propagation in an inhomogeneous medium in which the dielectric constant is proportional to  $r^{2m}$ , where  $r$  is the distance from the center of the earth. The expression for the dipole field in such a medium is generalized to apply in a medium in which the dielectric constant is an arbitrary function of  $r$  and is further transformed into a contour integral in a form convenient for calculations by the saddle-point method. Geometrical expressions are also derived for waves propagated in a duct.

**621.396.11:551.510.535** 546  
**The Reflexion of Vertically Incident Long Radio Waves from the Ionosphere when the Earth's Magnetic Field is Oblique**—J. Heading. (*Proc. roy. Soc. A.*, vol. 231, pp. 414–435; September 6, 1955.) The ionosphere is considered as comprising a lower region, in which the influence of collision frequency is important, and an upper region in which the influence of the magnetic field predominates. The equations for the lower region are solved for an exponential distribution of electron density; those for the upper region are solved for the case of oblique propagation when the plane of incidence coincides with the magnetic meridian. Expressions are obtained for the reflection and transmission coefficients of the lower region and for the reflection and conversion coefficients of the upper region.

**621.396.11:551.594.5** 547  
**Auroral Echoes observed North of the Auroral Zone on 51.9 Mc/s**—Dycc. (See 429.)

**621.396.11:551.594.5** 548  
**Double-Doppler Radar Investigations of Aurora**—McNamara. (See 428.)

**621.396.11.029.55:621.396.824** 549  
**Some Considerations on Measurement of Bearings of the Incoming Short Waves: Part 2**—I. Kasuya. (*J. Radio Res. Labs., Japan*, vol. 2, pp. 77–83; January, 1955.) The measurements described in part 1 (2091 of 1955) were

continued during a period of disturbed ionospheric conditions (March 18–24, 1954); previous conclusions regarding the effect of ionosphere tilting on lateral deviation are confirmed. Examples are given of lateral deviations corresponding to tilts in directions other than E-W. Tilting may correspond to curvature of the ionosphere with a space periodicity of 10–100 km.

**621.396.11.029.62:621.396.82** 550  
**Long-Distance V.H.F. Interference [in Britain]**—T. W. Bennington. (*Wireless World*, vol. 61, pp. 592–596; December, 1955.) In conditions of abnormal propagation interference may be caused by stations distant 200–1,400 miles. The effect may be due to (a) intense ionospheric  $E_s$ , which permits propagation of frequencies up to about 60 mc for about 1 per cent of the time, mainly during summer daytime, or more frequently, (b) tropospheric inversion layers, which may produce interference over the frequency band 40–100 mc at ranges up to 500 miles. The effects are unlikely to be serious for the fm sound services since strong signals in fm receivers tend to suppress weaker ones.

#### RECEPTION

**621.396.62:[621.376.23+621.376.33]** 551  
**A.M.-F.M. Demodulator**—P. Kundu. (*Wireless Engr.*, vol. 32, p. 337; December, 1955.) A demodulation method is outlined based on the variation of slope of the flanks of pulses obtained by limiting sinusoidal signals. [See also 2737 of 1955 (Das).]

**621.396.62:621.376.3** 552  
**Causes of the "Spitting" Effect in U.S.W. Transmission**—E. Belger. (*Tech. Hausmitt. Nordw.Dtsch. Rdfunks*, vol. 7, pp. 149–150; 1955.) Discussion of a defect observed in fm reception when the receiver bandwidth is too narrow; the effect is due to spurious amplitude modulation resulting from frequency deviations on the flanks of the filter characteristics.

**621.396.62.012.3** 553  
**Noise Factor Nomograph**—S. McCarrell. (*Electronics*, vol. 28, p. 174; November, 1955.) A chart for receiver design is presented, relating bandwidth, noise factor, and power in the antenna circuit.

**621.396.621** 554  
**Sensitive Three-Valve T.R.F. Receiver**—H. E. Styles. (*Wireless World*, vol. 61, pp. 616–620; December, 1955.) The receiver incorporates the amplified agc system described by Amos and Johnstone (1092 of 1952) and the negative-feedback volume control described by Osbourne (*ibid.*, vol. 60, pp. 165–168; April, 1954).

**621.396.621.54** 555  
**On the Principle and Design of a Trigger Circuit of a Signal-Seeking Radio using "Difference-Voltage"**—Chih Chi Hsu. (PROC. IRE, vol. 43, Part 1, pp. 1591–1607; November, 1955.) Detailed discussion of the operation of a receiver in which the signal-seeking circuit is switched off, when the signal is found, by a pulse corresponding to the difference between the secondary and primary voltages of the i.f. output transformer. The arrangement provides constant anticipation in face of signal-strength variations; a simple expression is derived for the amount of anticipation. Errors arising in the trigger circuit and those due to nonlinearity of the tuner are examined. Numerical examples are given.

**621.396.621.54.029.53/.55** 556  
**Frequency Stability and Setting Accuracy of the Short-Wave Communication Receiver E 104**—W. Hasselbeck. (*Telefunken Ztg.*, vol. 28, pp. 39–45; March, 1955. English summary, p. 61.) The receiver is mains-operated and

covers the frequency range 1.1–30 mc in 17 bands. The first i.f. is variable, the local oscillator being crystal controlled. The second i.f. is fixed at 525 kc. Methods of ensuring high frequency stability are described, including special elastic couplings for the tuning capacitors. The "setting accuracy" of the frequency adjustment, considering all possible sources of error, is calculated on a basis of 99.7 per cent probability to be within 1.5 kc.

621.396.822 557  
**Statistical Characteristics of Noise in the Presence of a Carrier Wave**—E. Divoire. (*Rev. HF, Brussels*, vol. 3, pp. 93–106; 1955.) Analysis is presented for a system using a linear detector and the results are compared with those obtained experimentally; the assumption of a Gaussian noise distribution appears to be justified.

621.396.822:621.317.794 558  
**A Comparison of Two Radiometer Circuits**—Goldstein. (See 535.)

### STATIONS AND COMMUNICATION SYSTEMS

621.39 559  
**IRE Symposium on Global Communications, Washington, D.C., June 23–25, 1954**—(TRANS. IRE, vol. CS-2, pp. 1–112; November, 1954.) The text is given of over 20 papers presented.

621.39 560  
**IRE-A.I.E.E. Symposium on Military Communications, New York, N.Y., April 28, 1954**—(TRANS. IRE, vol. CS-2, pp. 113–173; November, 1954.) The text is given of 12 papers of which all but one were presented at the symposium, and all are reprinted from *Trans. Amer. Inst. elect. Engrs., Communication and Electronics*; November, 1954.

621.39:621.376.5 561  
**Signal Analysis and Audio Characteristics of Pulse-Slope Modulation**—J. Das. (*Electronic Engng.*, vol. 27, pp. 482–487; November, 1955.) Further theoretical and experimental work on the method described previously (2737 of 1955) is reported. Working with a pulse repetition frequency of 10 kc and pulse duration of 10  $\mu$ s, the modulation is linear over an input af volume range of 35 db; the af gain of the system is constant within  $\pm 5$  db up to 3 kc and average distortion is  $< 5$  per cent for an input volume variation of 30 db.

621.39.001.11:621.376.5 562  
**Electrical Pulse Communication Systems: Part 2—Message Encoding and Signal Formation in Pulse Systems**—R. Filipowsky. (*J. Brit. Instn. Radio Engrs.*, vol. 15, pp. 483–504; October, 1955.) "Five specifications should be known of an information source: dimensionality; maximum information content and peak rate of information production; average rate of information production; auto-correlation function, and statistical fine structure of the source. Various sources are discussed with reference to the specifications. Message encoding is split into two distinct operations: space matching and entropy matching. The former process has to reduce the dimensionality of the message space to match the three-dimensional signal space, the latter has to remove redundancy. Signal formation involves sampling, quantization, and pulse modulation. The typical pulse waveforms are compared and their frequency spectra are listed. Signal encoding is considered as a linear transformation of the signal space into the channel space for the sole purpose of matching it to the requirements of a noisy channel of limited bandwidth." Part 1: 261 of 1955.

621.394.5/6 563  
**Signalling Systems for Submarine Tele-**

**graph Circuits**—C. J. Hughes. (*Proc. Instn. elect. Engrs.*, Part B, vol. 102, pp. 831–835; November, 1955.)

621.396.3 564  
**Multiple-Frequency-Shift Teletype Systems**—D. B. Jordan, H. Greenberg, E. E. Eldredge, and W. Serniuk. (*Proc. IRE*, vol. 43, Part 1, pp. 1647–1655; November, 1955.) By shifting the carrier to one of a number of different frequencies instead of, as in ordinary frequency-shift keying, only one, it is possible to extend the pulse duration without lowering the transmission rate, so that narrower detection bandwidths can be used, with improved signal/noise ratio and reduced errors. Analysis is presented based on information theory. Detailed calculations are made for a 6-frequency and a 32-frequency system. Two-frequency equipment can be adapted; circuits for coding, filtering etc. are described and experimental results reported.

621.396.4:621.396.65 565  
**An Introduction to some Technical Factors affecting Point-to-Point Radiocommunication Systems**—F. J. M. Laver. (*Proc. Instn. elect. Engrs.*, Part B, vol. 102, pp. 733–743; November, 1955.) A survey covering information-theory aspects, transmission systems, propagation factors, and coding, modulating, and multiplexing methods; 100 references.

621.396.41:621.376.5 566  
**Quadruphase—A New Approach to Time-Division Multiplexing**—W. E. Evans and R. F. Lowe. (*Elect. Engng., N.Y.*, vol. 74, pp. 685–688; August, 1955.) Digest of paper to be published in *Trans. Amer. Inst. elect. Engrs., Power Apparatus and Systems*, 1955. The control of the timing in the various channels is derived from a system of four sinusoidal oscillations at sampling frequency, with 90 degree phase spacings, using resistance networks to obtain the intermediate phases.

621.396.41:621.396.11.029.6 567  
**System Parameters using Tropospheric Scatter Propagation**—H. H. Beverage, E. A. Laport, and L. C. Simpson. (*RCA Rev.*, vol. 16, pp. 432–457; September, 1955.) "Accumulated data from published sources and from unpublished research on tropospheric forward scatter propagation are reviewed and condensed for practical application to fm communication systems. Antennas suitable for use on scatter paths are reviewed and the limitations on usable gains are discussed. General design methods for fm systems are presented and reduced to a design chart that includes the relationship of all parameters in a frequency-division multiplexed fm telephone system. Then follow computed values of transmitter power as functions of distance, frequency, and antenna size for a number of systems of practical interest using tropospheric forward scatter."

621.396.41:621.396.65.029.6 568  
**Wide-Band Microwave Radio Links**—S. Fedida. (*Marconi Rev.*, vol. 18, pp. 69–94; 3rd Quarter, 1955.) "A broad survey of the techniques used in the construction of wideband microwave links is given, with particular emphasis on the applications of traveling wave tubes, in these links. Some of the design requirements are examined in the light of the conclusions of the CCIR Study Group IX, meeting at Geneva, at the end of 1954."

621.396.71 569  
**Rugby Radio Extension**—(*Elect. J.*, vol. 155, p. 461; August 5, 1955.) Brief description of the British Post Office station extension opened in July, 1955 and housing 28 30-kw transmitters for the frequency range 4–27.5 mc controlled from a central cabin.

621.396.931 570  
**The Use of Radiotelephony for the Control**

**of Works Transport**—E. N. Farrar and M. T. O'Dwyer. (*J. Brit. Instn. Radio Engrs.*, vol. 15, pp. 519–525; October, 1955.)

### SUBSIDIARY APPARATUS

621-526(083.74) 571  
**IRE Standards on Graphical and Letter Symbols for Feedback Control Systems, 1955**—(PROC. IRE, vol. 43, Part 1, pp. 1608–1609; November, 1955.) Standard 55 IRE 26.S1.

621.311.6:621.316.722.1 572  
**Low-Ripple Adjustable Regulated Power Supply**—G. Hetland, Jr., and R. R. Buss. (*Electronics*, vol. 28, pp. 164–165; November, 1955.) A unit giving an output of 350–1,000 v with an output impedance  $> 10\Omega$  is described.

621.314.1:621.373.52:621.314.7 573  
**Transistor D.C. Convertors**—L. H. Light and P. M. Hooker. (*Proc. Instn. elect. Engrs.*, Part B, vol. 102, pp. 775–786; November, 1955. Discussion, pp. 786–792.) A transistor in a relaxation oscillator is arranged to interrupt a 1v circuit; energy is stored in the transformer inductance during the "on" period and is delivered to the output circuit at an increased voltage during the "off" period, the circuit thus acting as a step-up device. Design and operation of practical arrangements are discussed. A shorter account of the work is given in *Wireless World*, vol. 61, pp. 582–586; December, 1955.

621.314.63 574  
**Germanium Power Rectifiers**—G. A. Carrick. (*Trans. S. Afr. Inst. elect. Engrs.*, vol. 46, Part 7, pp. 197–211; July, 1955. Discussion, pp. 211–217. Paper reprinted in *B.T.N. Actw.*, vol. 26, pp. 173–185; November/December, 1955.)

621.316.722.1 575  
**Improving the Performance of the Series Electronic Voltage Regulator**—G. H. T. Hatton. (*Proc. Instn. Radio Engrs. Aust.*, vol. 16, pp. 308–311; September, 1955.) "Compensating networks for improving the performance of the conventional series electronic voltage-regulator circuit are analyzed. The theory is compared with measurements made on a fully-compensated circuit."

621.316.722.1 576  
**Effects of Heater-Voltage Variations of Valves in Certain Stabilizer Circuits**—F. A. Benson and G. V. G. Lusher. (*Electronic Engng.*, vol. 27, pp. 502–505; November, 1955.) Calculations further to those presented previously (1925 of 1954) show that, in series-parallel stabilizer circuits having a resistor in the cathode lead of the amplifier, the effect of heater-voltage variations is not serious because the two tubes produce output-voltage changes of opposite sign.

### TELEVISION AND PHOTOTELEGRAPHY

621.397.242 577  
**Television Transmission on Cables**—K. Barthel. (*Arch. elekt. Übertragung*, vol. 9, pp. 341–349; August, 1955.) Distortion produced by ssb transmission can be corrected by (a) multiplicative mixing at the far end with a carrier of exactly correct phase, or (b) modulation to a depth  $> 100$  per cent so as to provide favorable operating conditions for the line amplifiers. Correction of distortion introduced by the line itself is performed by attenuation and phase equalizers; arrangements appropriate for line sections of average length 9.3 km transmitting frequencies from 300 kc to 6.2 mc are briefly indicated.

621.397.26:621.396.65.029.6 578  
**Microwave Television Transmission Systems**—W. L. Wright. (*Marconi Rev.*, vol. 18, pp. 95–118; 3rd Quarter, 1955.) The suitability for television purposes of the microwave radio

links discussed by Fedida (568 above) is compared with that of cable relay systems. Modulation and demodulation equipment is described with special consideration of the design of fm oscillators.

621.397.335:621.3.018.75 579

**Television Sync-Pulse Spectrum**—W. T. Cocking. (*Wireless Engr.*, vol. 32, pp. 313-315; December, 1955.) Fourier-series calculations relating to non sinusoidal wave-forms can be simplified by adding or multiplying some well known series. The structure of the British television synchronizing signal is considered as an example of application of this method.

621.397.5:535.623 580

**The ABC's of Color Television**—J. M. Barstow. (Proc. IRE, vol. 43, Part 1, pp. 1574-1579; November, 1955.) A description of the NTSC system in a form suitable for non-specialist engineers.

621.397.5:535.623 581

**Colour Television in the U.S.A.**—C. G. Mayer. (*Electronic Engng.*, vol. 27, pp. 488-491; November, 1955.) A brief review of progress made since the previous report (3367 of 1954).

621.397.5:535.623 582

**A Sequential System of Image Transmission in Natural Colours**—A. M. Varbanski. (*Vestnik Syvazi*, no. 3, pp. 6-9; 1955.) The physiology of color vision is discussed and a sequential system of color television adopted at the Moscow Experimental Station for Color Television is described. The distortion peculiar to this type of transmission is considered, and also the special requirements imposed on film transmission.

621.397.5:535.623 583

**Differential Chromaticity Thresholds in the Direction of Primary Blue in a Trichromatic-Synthesis System**—P. Billard. (*Rev. d'Optique*, vol. 34, pp. 371-405; July/August, 1955.) Detailed report of experiments made in connection with color-television studies. The results indicate that different colors should be compared at the maximum brightness levels which they can attain in a trichromatic synthesis. This applies particularly for hues close to primary blue; if the comparison is made with the colors at the same brightness level the sensitivity of the eye to small chromaticity differences is overestimated.

621.397.6 584

**Phase Pre-correction in Television Transmitters and Receivers**—J. Peters. (*Tech. Hausmitt. NordwDtsch. Rdfunks*, vol. 7, pp. 125-128; 1955.) Results of a comprehensive investigation are reviewed. Mathematical analysis of transients indicates that picture quality is effectively improved by phase equalization in the video-frequency channel only; these results are confirmed by measurements. Reasons are given for effecting the equalization entirely at the transmitter.

621.397.6:622.4 585

**Operation of Television Installations in Open-Cast Lignite Mining**—W. Meyer. (*Elektrotech. Z., Edn B*, vol. 7, pp. 286-289; August 21, 1955.) Operation in mines spanning the range from 117 m above sea level to 77 m below sea level is discussed. Television equipment is particularly useful for the dredgerman, since dredgers 90 m long may be used. Equipment is described with special reference to requirements for dust exclusion and proper illumination.

621.397.6:778 586

**Simple Equipment for obtaining Photographs of Single Television Pictures**—W. Dillenburger and J. Wolf. (*Frequenz*, vol. 9, pp. 296-298; September, 1955.) A switching circuit

is described for producing a single-scan picture with the same brightness values as in continuous operation.

621.397.6.001.4 587

**The Test-Line Technique in Television**—H. E. Fröling. (*Tech. Hausmitt. NordwDtsch. Rdfunks*, vol. 7, pp. 129-138; 1955.) Details are given of a method in which a special signal for testing transmission characteristics during a program is inserted at the end of the vertical blanking interval so as not to appear in the ordinary picture. The test waveform may include white, black, and grey levels, as well as pulses for testing linearity, reflections and amplitude, and phase variations.

621.397.61:535.623 588

**Matrixing and encoding Color for Telecasting**—H. Taub, J. Rabinowitz, D. Schacher, and M. Star. (*Electronics*, vol. 28, pp. 140-145; November, 1955.) Details are given of a unit which accepts as inputs the blanking, synchronizing, subcarrier, burst-key, and individual color signals and forms them into the composite signal appropriate for feeding to a transmitter operating on the NTSC color-television system.

621.397.61:778.55/.6 589

**Control of Light Intensity in Television Projectors**—K. Sadashige and B. F. Melchionni. (*J. Soc. Mot. Pict. Telev. Engrs.*, vol. 64, pp. 416-419; August, 1955.) The problem discussed is that of controlling the intensity of the source illuminating color film when using a vidicon camera tube, so as to maintain the video signal level independent of the average film density. An equipment is described in which the compensation is effected by controlling the angular position of a filter wedge in the projector condenser lens by means of a servomechanism.

621.397.61.001.4 590

**Test Equipment for the Belgian Television Transmitters**—W. Hamoir. (*Rev. HF, Brussels*, vol. 3, pp. 107-116; 1955.)

621.397.611.2 591

**The Development of the C.P.S.—Emitron Television Camera Tube**—J. D. McGee. (*Arch. elekt. Übertragung*, vol. 9, pp. 355-362; August, 1955.) Refinements incorporated in later versions of this tube include use of a mesh close in front of the target to stabilize the tube against extra-strong illumination, and use of slightly conducting glass as the material for the target plate to increase the storage capacity and thus extend the contrast range without introducing time lag.

621.397.62 592

**Circuits and Components for 90° Scanning**—(Mullard tech. Commun., vol. 2, pp. 89-111; August, 1955.) The issue includes papers on line and frame timebase circuits for 90 degree scanning, together with some details of the deflection units, cr tubes, and tubes.

621.397.62:621.373.4 593

**Frequency Characteristics of Local Oscillators**—W. Y. Pan. (*RCA Rev.*, vol. 16, pp. 379-397; September, 1955.) An examination is made of the effect on frequency stability of the heat developed during operation in local oscillators used in vhf and uhf television receivers. Compensation methods, especially for the warm-up period, are indicated.

621.397.62:621.375.221.029.62 594

**Phase-Linear Television Receivers**—A. van Weel. (*Philips Res. Rep.*, vol. 10, pp. 281-298; August, 1955.) A receiver with phase-linear i.f. amplifier is described, using conventional circuits and giving normal selectivity. The performance compares favorably with that of receivers in which phase errors are compensated in the video-frequency stages of either transmitter or receiver.

621.397.8 555

**The Fixing of Nonlinearity Tolerances for Television Transmission Systems**—S. Funk. (*NachrTech.*, vol. 5, pp. 347-350; August, 1955.) The permissible nonlinearity is discussed in relation to the physiology of vision; a maximum picture contrast of about 1:100 is assumed, with a grey scale of 20 distinguishable steps. In relation to a normalized system transfer characteristic with unity slope, the tolerance on the slope is about 10 per cent up or down. A special signal and test method are described for adjusting the system to conform to these tolerances.

621.397.8 596

**The Influence of the Optical System on the Modulation Depth in Television Pickup Devices**—W. Dillenburger. (*Frequenz*, vol. 9, pp. 293-296; September, 1955.) Measurements on known types of objective are reported. It is possible to stop them down so that in practice they have no influence on the frequency variation of modulation depth. Loss of modulation is bound to occur when a television picture is recorded and rescanned or when a standards conversion is effected.

## TRANSMISSION

621.396.61:621.376.222 597

**Series Tube modulates Amplifier Screen-Grid**—W. B. Bernard. (*Electronics*, vol. 28, pp. 158-160; November, 1955.) Low-level modulation circuits are discussed in which the modulating tube is in series with the screen-grid supply to the modulated amplifying tube. Modulating signals ranging from dc to very high frequency can be handled. Arrangements are described using feedback to correct a non-linear relation between the screen-grid voltage and the power output. A circuit for protecting the modulated tube is also described. The system simplifies controlled-carrier operation.

## TUBES AND THERMIONICS

621.314.63 598

**The Dependence of the Current Density of a  $p-i-n$  Rectifier on the Width of the Intermediate Zone**—A. Herlet. (*Z. Phys.*, vol. 141, pp. 335-345; July 20, 1955.) The current density increases with increasing intermediate-zone width for values of the latter up to twice the carrier-diffusion length, but decreases for intermediate-zone widths greater than this. The mechanism is discussed on the basis that in the first case the separate zones constitute current sources which act in combination, while in the second case the paths in the different zones combine as for ordinary series resistances.

621.314.63:[546.28+546.289 599

**On the Inductive Part in the A.C. Characteristic of the Semiconductor Diodes**—Y. Kanai. (*J. phys. Soc. Japan*, vol. 10, pp. 719-720; August, 1955.) The susceptance of Si and Ge  $p-n$  junction diodes was determined at frequencies from 3 kc to 5 mc. With a forward bias voltage the susceptance decreased at high frequencies, the experimental results thus deviating from Shockley's theory. This decrease can be explained by postulating a series inductive component associated with the conductivity modulation caused by hole injection.

621.314.63+621.314.7]:621.396.822 600

**Theory of Shot Noise in Junction Diodes and Junction Transistors**—A. van der Ziel. (Proc. IRE, vol. 43, Part 1, pp. 1639-1646; November, 1955.) Noise caused by random diffusion of minority carriers and random recombination of minority and majority carriers is investigated by means of a transmission-line analogy proposed by North, in which the diffusion corresponds to the presence of series noise-voltage generators while the recombination corresponds to parallel noise-current generators. For low frequencies the equivalent

circuits thus derived correspond to those derived previously, but for high frequencies the new method gives a more accurate representation of the noise properties. The theory takes account of volume recombination only.

**621.314.632:621.396.822** 601  
**Noise in Silicon Microwave Diodes**—G. R. Nicoll. (*Proc. Instn. elect. Engrs.*, Part B, vol. 102, pp. 786-792; November, 1955.) Discussion on 294 of 1955.

**621.314.7** 602  
**Transistors and their Production**—J. Malsch. (*Elektrotech. Z., Edn B*, vol. 7, pp. 273-278; August 21, 1955.) A survey including a brief illustrated account of the production of alloyed-junction transistors.

**621.314.7** 603  
**"Step" and "Oscillation" Phenomena in the Collector of A-Type Transistors**—M. Kikuchi and Y. Tarui. (*J. phys. Soc. Japan*, vol. 10, pp. 722-723; August, 1955.) Further investigation of the "step" effect (880 of 1955), using the transistor collector as a diode and the emitter as subsidiary electrode, showed that the "step" occurred earlier in the presence of hole current from the emitter. An "oscillation" in the collector voltage was sometimes observed, following just after the "step." An oscillogram is shown and a possible explanation of the phenomenon is very briefly discussed. [See also 3070 of 1954 (Lempicki and Wood).]

**621.314.7** 604  
**Self-Bias Cut-Off Effect in Power Transistors**—N. H. Fletcher. (*Proc. IRE*, vol. 43, Part 1, p. 1669; November, 1955.) Analysis is given which is valid for higher levels of injected-carrier density than those discussed previously (2463 of 1955).

**621.314.7:621.317.7** 605  
**Simplified Transistor Test Equipment**—Bentley, Ghandi, and Mathis. (See 526.)

**621.314.7:621.396.822** 606  
**Measurements of Junction-Transistor Noise in the Frequency Range 7-50 kc/s**—W. L. Stephenson. (*Proc. Instn. elect. Engrs.*, Part B, vol. 102, pp. 753-756; November, 1955. Discussion, pp. 786-792.) The measurements were made using a superheterodyne arrangement with narrow-band filter in the i.f. amplifier, giving constant bandwidth over the frequency range; the influence of collector voltage and current and of temperature was studied. Results are analyzed on the basis of two equivalent noise generators in the input circuit; they indicate that (a) the noise factor exhibits a minimum at about 25 kc, (b) the optimum source resistance is independent of frequency, (c) the optimum source resistance is not directly related to the input resistance, and (d) the noise is independent of collector voltage.

**621.314.7.012.8** 607  
**The Natural Equivalent Circuit of Junction Transistors**—J. Zawels. (*RCA Rev.*, vol. 16, pp. 360-378; September, 1955.) The equivalent circuit is derived by considering the details of transistor action, the method being a generalization of that presented previously (300 of 1955). The resulting circuit comprises a passive network in cascade with a frequency-independent amplifier. A method is indicated for computing the parameters of the equivalent circuit from spot measurements of the  $h$  parameters.

**621.383.2** 608  
**New Photoemissive Cathodes of High Sensitivity**—A. H. Sommer. (*Rev. sci. Instrum.*, vol. 26, pp. 725-726; July, 1955.) Photocathodes consisting of Sb and more than one alkali metal in combination show much higher sensitivity in the visible spectrum, especially to red light than those containing only one such metal.

**621.383.2** 609  
**Discontinuities in the Saturation Curves of Vacuum Photocells**—J. S. Preston and G. W. Gordon-Smith. (*Brit. J. appl. Phys.*, vol. 6, pp. 329-333; September, 1955.) Conditions under which certain types of photoemissive cells can operate in either of two stable states are discussed. The best conditions for saturation and regular behavior are obtained if the inner surface of the envelope is highly conducting and is in good connection with the anode, but insulated from the cathode.

**621.383.27** 610  
**Instability of Photomultipliers**—L. P. de Valencé. (*Brit. J. appl. Phys.*, vol. 6, pp. 311-313; September, 1955.) Dark-current instability of certain types of electrostatically focused tubes operated with cathode at high negative potential is ascribed to defocusing effects between the photocathode and first dynode and to positive envelope potentials. Stability is secured by connecting the glass envelope to the cathode or second dynode.

**621.383.4** 611  
**High-Sensitivity Photoconductor Layers**—S. M. Thomsen and R. H. Bube. (*Rev. sci. Instrum.*, vol. 26, pp. 664-665; July, 1955.) Microcrystalline powders of CdS or CdSe fixed with plastic material, or sintered on to suitable surfaces, give large-area layers having most of the desirable characteristics of single crystals, with advantages in increased red sensitivity, in the case of CdS layers, and in the ohmic character of sintered layers with silver-paste electrodes.

**621.383.4** 612  
**Large-Area High-Current Photoconductive Cells using Cadmium Sulfide Powder**—F. H. Nicoll and B. Kazan. (*J. opt. Soc. Amer.*, vol. 45, pp. 647-650; August, 1955.) Photoconductive layers are prepared from CdS powder, with particle sizes  $<50\mu$ , and a binder such as ethyl cellulose or polystyrene. The layer is applied to a support such as glass by spraying, silk screening, etc. Various possible constructions, are described; cells can readily be made capable of carrying photocurrents of 1A or more in room light. Build-up and decay time constants of the order of 0.1 second have been obtained.

**621.383.5** 613  
**The Stability of Selenium Photocells**—H. Wörner. (*Z. Met.*, vol. 9, pp. 248-250; August, 1955.) Tests made on barrier-layer cells after two years' service indicate an appreciable decrease of sensitivity. The amount of the decrease varies greatly from cell to cell and may be as high as 30 per cent; it depends on both fatigue and aging effects.

**621.383.5:537.311.33:546.289** 614  
**Influence of Diffusion Length and Surface Recombination on the Barrier-Layer Photoelectric Effect in Germanium**—H. U. Harten and W. Schultz. (*Z. Phys.*, vol. 141, pp. 319-334; July 20, 1955.) Photovoltaic cells of large area can be produced by evaporating a transparent gold film on to Ge plates. From the sensitivity/wavelength characteristic the diffusion length of the minority carriers can be deduced using "thick" Ge plates, and the surface recombination velocity can be deduced using "thin" plates.

**621.383.5:621.314.63:621.375.3** 615  
**A Germanium Diffused-Junction Photoelectric Cell**—J. M. Waddell, S. E. Mayer and S. Kaye. (*Proc. Instn. elect. Engrs.*, Part B, vol. 102, pp. 757-762; November, 1955. Discussion, pp. 786-792.) Descriptions are given of practical forms of a cell in which the  $p-n$  junction is produced by impurity diffusion; desirable features are low noise, high sensitivity, and extended long-wave response. Temperature rise

is more important than absolute temperature level for determining the maximum ratings. Applications discussed include a magnetic amplifier making use of the high forward conductance of the cell.

**621.385+621.314.7]:621.396.822** 616  
**Characterization of the Noise of Tubes and Transistors by Four Measurable quantities**—H. Groendijk and K. S. Knol. (*Tijdschr. ned. Radiogenoot.*, vol. 20, pp. 243-256; July, 1955. In English.) The problem is investigated on the one hand by considering the mechanisms of noise production, and on the other by considering the tube or transistor as a linear quadripole. In general, the four measurable quantities characterizing the noise are not simply related to the physical phenomena giving rise to noise. The frequency dependence of the noise-characterizing quantities is discussed.

**621.385.002.2** 617  
**Thermionic Valves of Improved Quality for Government and Industrial Purposes**—E. G. Rowe, P. Welch and W. W. Wright. (*Proc. Instn. elect. Engrs.*, Part B, vol. 102, pp. 801-803; November, 1955.) Discussion on 2789 of 1955.

**621.385.029.6** 618  
**Focusing Electron Beams by Magnetic Fields**—W. Kleen and K. Pöschl. (*Arch. elekt. Übertragung*, vol. 9, pp. 295-298; July, 1955.) A simplified analytical method is developed for determining the mean radius and the maximum radial expansion of a cylindrical beam from a concave cathode with either uniform or periodic magnetic focusing.

**621.385.029.6** 619  
**Theory of Coupled Space-Charge Waves**—F. Paschke. (*Frequenz*, vol. 9, pp. 273-279; August, 1955.) Pierce's theory developed for traveling-wave tubes is extended by taking account of the displacement current in the direction of the beam. Calculation of the gain is reduced to a simple boundary-tube problem. The theory is applicable only for very low beam current, very short wavelengths, or very high coupling resistance. Calculations for an amplifier tube with two adjacent flat beams give a gain smaller by a factor of  $1/\sqrt{2}$  than for a tube with overlapping beams.

**621.385.029.6** 620  
**The Carmatron, a New Electronically Tuned Wide-Band Oscillator**—R. Warnecke, J. Nalot, B. Epszstein, and O. Doehler. (*C.R. Acad. Sci., Paris*, vol. 241, pp. 695-698; September 12, 1955.) A tube combining desirable features of the magnetron and the  $M$ -type carcinotron has an axial cathode surrounded by a coaxial anode constituted by a slightly dispersive interdigital delay line. Hf energy is extracted by a coaxial line. A magnetic field is applied in a direction such that the output and the end of the delay line are coupled not by the hf field but by the circulating electron beam. The tube will oscillate when the electron transit angle is a multiple of  $2\pi$ . Electronic tuning bands of 25-30 per cent are possible in conjunction with high efficiencies. The theory has been verified by experiments on a tube for the 3-kmc band.

**621.385.029.6** 621  
**Periodic-Magnetic-Field Focusing for Low-Noise Traveling-Wave Tubes**—K. K. N. Chang. (*RCA Rev.*, vol. 16, pp. 423-431; September, 1955.) The beam-focusing arrangements described comprise a magnet producing a uniform field in the gun region, a magnet system producing a space-periodic field in the helix region, and a matching device between the two. Measurements on a tube operating at 3 kmc indicate that gain and noise figures are comparable with those for a tube using a uniform focusing field.

- 621.385.029.6 622  
**Extension of "The Effect of Initial Noise Current and Velocity Correlation on the Noise Figure of Traveling-Wave Tubes"**—W. R. Beam. (*RCA Rev.*, vol. 16, pp. 458-460; September, 1955.) Amendments are proposed to the analysis presented by Bloom (3788 of 1955).
- 621.385.029.6 623  
**Positive-Ion Drainage in Magnetically Focused Electron Beams**—M. E. Hines, G. W. Hoffman, and J. A. Saloom. (*J. appl. Phys.*, vol. 26, pp. 1157-1162; September, 1955.) Analysis is presented for the focusing of long electron beams when both axial magnetic field and space-charge neutralization by positive ions are operative. The theory is checked by measurements of the ion current collected from a long drift tube at various instants after application of a step signal. Results indicate that positive ions may be trapped at regions along the beam such that the axial variations of beam diameter are enhanced. [See also 305 of 1955 (Ginzton and Wadia).]
- 621.385.029.6 624  
**The Cascade Backward-Wave Amplifier: a High-Gain Voltage-Tuned Filter for Microwaves**—M. R. Currie and J. R. Whinnery. (*Proc. IRE*, vol. 43, Part 1, pp. 1617-1631; November, 1955.) Operation of the backward-wave tube as a narrow-band amplifier is discussed. A "cascade" arrangement is described in which the beam traverses in succession a modulator helix, a drift tube or other intermediate section, and a demodulator helix. The tube can be turned over a wide range of frequencies by varying the beam voltage, and the bandwidth can be controlled by stagger-tuning the input and output. The minimum noise figure should be of the same order as that of an ordinary traveling-wave tube; *i.e.*, about 6 db.
- 621.385.032.216 625  
**Changes in the Structure of Oxide Cathodes at High Temperatures**—H. P. Rocksöy. (*Brit. J. appl. Phys.*, vol. 6, pp. 272-276; August, 1955.) Examination by x-ray microbeam technique indicates that as a result of heat treatment, at 900°-1,150°C with BaO and 1,100°-1,250°C with SrO, crystallites of dimensions 2-5  $\mu$  are normally developed. A gradual increase in the structure-cell dimensions takes place with increasing temperature of heating in vacuum; this is attributed to a progressive increase in the numbers of lattice defects and in the case of BaO appears to correspond with the process of therniomic activation.
- 621.385.032.216 626  
**Oxide-Impregnated Nickel-Matrix Cathode**—W. Balas, J. Dempsey, and E. F. Rexer. (*J. appl. Phys.*, vol. 26, pp. 1163-1165; September, 1955.) Description of the preparation and performance of a dispenser-type cathode with properties intermediate between those of the *I* type and those of the ordinary oxide cathode.
- 621.385.032.216 627  
**An X-Ray Study of Barium-Strontium-Calcium Triple Oxide**—J. Terada. (*J. phys. Soc. Japan*, vol. 10, pp. 555-565; July, 1955.) The experimental results are discussed; the increased emission of the triple oxide over that of a double or single oxide may be due to the increased possibility of crystal distortion by a given heat treatment.
- 621.385.032.216 628  
**Emission from Hollow Cathodes**—K. M. Poole. (*J. appl. Phys.*, vol. 26, pp. 1176-1179; September, 1955.) Experimental evidence indicates that the emission from an internally coated hollow cathode includes a component from cathode material deposited round the opening, this subsidiary component becoming saturated at lower anode voltages than the main component.
- 621.385.032.216:546:546.431/432]-31 629  
**On the Relations between Electron Emission, Conduction and Noise of Oxide-Coated Cathodes**—J. Nakai, Y. Inuishi and Y. Tsung-Che. (*J. phys. Soc. Japan*, vol. 10, pp. 437-443; June, 1955.) Experimental results of measurements on (Ba, Sr)O cathodes are presented graphically and discussed with reference to the pore-conduction mechanism considered earlier by Young (896 of 1953) and others.
- 621.385.032.216:621.375.9 630  
**Properties of Pore Conductors**—R. Forman. (*J. appl. Phys.*, vol. 26, pp. 1187; September, 1955.) Following observations of anomalous conduction in oxide cathodes (2158 of 1955), experiments were made with porous thoria cylinders. At temperatures of 1,500°-1,600°C large transverse magnetoresistance effects were observed at comparatively low field strengths. An amplifying device is outlined based on the change of resistance of an oxide cathode coating subjected to variations of the es field in front of it; the characteristics resemble those of a conventional triode.
- 621.385.032.216.2 631  
**Surface Treatment of Core Metal used for Oxide-Coated Cathode**—J. Nakai and S. Nakamura. (*J. phys. Soc. Japan*, vol. 10, pp. 566-570; July, 1955.) Emission from oxide cathodes coated on to sleeves made of Ni containing 0.10 per cent Mg and 0.17 per cent Si as active materials can be increased by removing the surface contamination on the sleeves by an electrolytic treatment. The increased emission is probably due to the active material in the sleeve producing excess Ba by reduction of the cathode oxide.
- 621.385.032.24 632  
**Decrease of Grid Emission by Improvement of Electroplating**—T. Hashimoto and A. Yokoyama. (*Rep. elect. Commun. Lab., Japan*, vol. 3, pp. 12-14; May, 1955.) An experimental investigation is reported of plating techniques for improving the adhesion of Au coatings deposited on tube grids to inhibit emission. Use of a thin layer of Pt over the Au is discussed. Both Mo and Ni are considered as base materials.
- 621.385.13:621.373.4:537.5 633  
**The Appearance of Some Oscillating Discharges**—T. K. Allen, R. A. Bailey, and K. G. Emeleus. (*Brit. J. appl. Phys.*, vol. 6, pp. 320-322; September, 1955.) Hot-cathode rectifiers and thyratrons containing gas at pressures of the order of  $10^{-3}$  mm Hg are found to generate internal oscillations in the cm- $\lambda$  and dm- $\lambda$  bands, probably due to interaction between the primary and plasma electrons. Observed phenomena are described and the mechanism of their production is discussed.
- 621.385.3 634  
**On the Electron-Optical Action of Grid Systems**—A. M. Strashkevich and A. S. Reyzlin. (*Radiotekhnika, Moscow*, vol. 10, pp. 66-71; February, 1955.) The design of any multi-electrode tube can be reduced to the design of a number of equivalent triodes. A precise formula is derived for determining the distribution of potential in a plane triode. The dependence of the position of the focus on the electrical and geometrical parameters is investigated.
- 621.385.4 635  
**A Beam Power Tube for Ultra-high-Frequency Service**—W. P. Bennett. (*RCA Rev.*, vol. 16, pp. 321-338; September, 1955.) Details are given of the construction and performance of the Type-6448 tetrode [see also 3770 of 1955 (Koros)]; some appropriate circuit arrangements are outlined.
- 621.385.832:535.871.07 636  
**Sedimentation of Fluorescent Screens in Cathode-Ray Tubes**—F. de Boer and H. Emmens. (*Philips tech. Rev.*, vol. 16, pp. 232-236; February, 1955.) The processes involved in sedimentation are discussed. The effect of gelatinizing agents on the screen adhesion is very pronounced; barium salts are preferred to potassium sulphate for their more rapid action in this respect. The use of radioactive tracers to analyze the screen composition is described.
- 621.385.832:535.371.07 637  
**Sticking Potential of C.R.T. Screens**—K. H. J. Rottgardt and W. Berthold. (*J. appl. Phys.*, vol. 26, p. 1180; September, 1955.) Experiments further to those described previously by Rottgardt et al. (2167 of 1955) indicate that the sticking potential of screens in sealed-off television tubes is not noticeably influenced by the vapors from the pumps used.
- 621.385.832.002.2 638  
**Cathode-Ray-Tube Manufacture**—(*Elect. Rev., Lond.*, vol. 157, pp. 86-87; July 8, 1955.) Brief description of new plant for producing the glass components of cr tubes.
- 621.387 639  
**The Current Rise in Gas-filled Triodes and Tetrodes**—E. Knoop. (*Z. angew. Phys.*, vol. 7, pp. 366-371; August, 1955.) An approximate formula is derived for the exponential current rise. The effects of the anode potential, heater voltage, and nature and pressure of the gas are discussed. Experimental results, which are in fair agreement with theory, indicate that tubes with fast current rise can be produced using hydrogen or an inert gas of higher atomic number (*e.g.*, Xe); the effect of the electrode geometry on the rise time is small.
- 621.387:621.316.722.1 640  
**Glow-Discharge Stabilizers**—F. A. Benson and L. J. Bental. (*Wireless Engr.*, vol. 32, pp. 330-336; December, 1955.) Measurements have been made to determine the influence of gas filling, gas pressure, and direct operating current on the impedance/frequency characteristics of stabilizer tubes over the range 20 cps-100 kc; the tubes had either Ni- or Ce-alloy cathodes. The results indicate that for eliminating low-frequency ripple on a rectifier output, tubes with He filling are best; where there is a high-frequency ripple component, Ne-filled tubes should be used.